

Service Manual

COMPACT
disc
DIGITAL AUDIO

**SHOCK
WAVE**

MASH[®]
multi-stage noise shaping

※ • MASH is a trademark of NTT.

Portable CD Player

SL-SW415

Colour (S) ... Silver Type

Areas

EB Great Britain.
EG Europe.
GC Asia, Latin America,
Middle East and Africa.
GN Oceania.
GH Hong Kong.



Traverse Deck: RAE0142Z Mechanism Series

Specifications

Audio

No. of channels: 2 channels (left and right, stereo)
Output voltage: 0.6 V(50 kohm) diameter 3.5 stereo mini jack
Frequency response: 20—20,000 Hz (+0.5 dB, -1.5 dB)
S/N: More than 94 dB*
Wow and flutter: Below measurable limit
DA converter: 1 bit, MASH[®]
Headphones output level: Max. 9 mW+9 mW/16 ohm (variable)
stereo mini jack diameter 3.5
Digital filter: 8 times over sampling

Signal Format

Correction system: Technics New
Super Decoding Algorithm

Pickup

Type: One beam
Light source: Semiconductor laser
Wavelength: 780 nm
Lens: Glass pressed lens

Playing time

(When used in hold mode, at 25 degree temperature and on flat and stable surface.)

Batteries used: Extra anti-shock OFF/ON

Panasonic Alkaline dry cell batteries(LR6, 2pcs.); : Approx. 12h/10h

Rechargeable batteries

RFKFP3GAVE2S, RFKFP3GAVT2S

(When rechargeable 5 hours.)

: Approx. 6.5h / 5.5h

SH-CDB8D (When rechargeable 3 hours.)

: Approx. 3.5h / 3.0h

The play time may be less depending on the operating conditions.

General

Operation temperature range: 0 — 40 degree
Rechargeable temperature range: 5 — 40 degree
Power supply: DC 4.5 V
Power consumption (Extra anti-shock OFF/ON)
AC adaptor; 5.1W/5.2W
Battery (DC 3V); 0.5W/0.6W
When recharging; 4.3W
Dimensions : 135.0(Wide)/34.0(High)/150.5(Depth)mm
Weight: 355 g (with batteries)
310 g (without batteries)

*These specifications were measured in the extra anti-shock OFF mode.

Note: Specifications are subject to change without notice.

Weight and dimensions are approximate.

⚠ WARNING

This service information is designed for experienced repair technicians only and is not designed for use by the general public. It does not contain warnings or cautions to advise non-technical individuals of potential dangers in attempting to service a product. Products powered by electricity should be serviced or repaired only by experienced professional technicians. Any attempt to service or repair the product or products dealt with in this service information by anyone else could result in serious injury or death.

Panasonic[®]

© 1997 Matsushita Electric Industrial Co., Ltd.
All rights reserved. Unauthorized copying and
distribution is a violation of law.

Contents

	Page		Page
Precaution of Laser Diode	2	Masurements and Adjustments	15,16
Accessories	3	Outline of 10-Second Sound Keeper Technique Used for Prevention of Sound from Skipping	16
Location of Controls	3	Block Diagram	17 ~ 20
Power Supply Preparations	3	Schematic Diagram	21 ~ 25
Sequential Play	4	Type Illustration of IC's Transistors and Diodes	21
Other Play Methods	5	Printed Circuit Board and Wiring Connection Diagram	26,27
Using the Unit with Operation Accessories	5	Terminal Function of IC's	28 ~ 32
Extra Anti-shock Function	6	Replacement Parts List (Electrical)	33
Accidental Operation Prevention Function	6	Cabinet Parts Location	34
Troubleshooting Guide	6	Replacement Parts List (Cabinet, Accessories, Packing and Grease or Jig/Tool)	35,36
Maintenance	6	Supply of Rechargeable Battery Ass'y as Replacement Parts	36
Cautions	7	Caution in Use of Rechargeable Battery Ass'y	36
Concerning Compact Discs	7	Packaging	36
Handling Precautions for Traverse Deck	8	Resistors and Capacitors	37
Operation Checks and Main Component Replacement Procedures	9 ~ 12		
Checking the Operation Problems on the Traverse Deck (Optical Pickup)	13		
Automatic Adjustment Results Display Function (Self-check Function)	14, 15		

Precaution of Laser Diode

CAUTION: This product utilizes a laser diode with the unit turned "on", invisible laser radiation is emitted from the pickup lens.

Wave length: 780 nm

Maximum output radiation power from pickup: 100 μ W/VDE

Laser radiation from the pickup lens is safety level, but be sure the followings:

1. Do not disassemble the optical pickup unit, since radiation from exposed laser diode is dangerous.
2. Do not adjust the variable resistor on the pickup unit. It was already adjusted.
3. Do not look at the focus lens using optical instruments.
4. Recommend not to look at pickup lens for a long time.

ACHTUNG: Dieses Produkt enthält eine Lasereinheit. Im eingeschalteten Zustand wird unsichtbare Laserstrahlung von der Lasereinheit abgestrahlt.

Wellenlänge: 780 nm

Maximale Strahlungsleistung der Lasereinheit: 100 μ W/VDE

Die Strahlung an der Lasereinheit ist ungefährlich, wenn folgende Punkte beachtet werden:

1. Die Lasereinheit nicht zerlegen, da die Strahlung an der freigelegten Laserdiode gefährlich ist.
2. Den werkseitig justierten Einstellregler der Lasereinheit nicht verstellen.
3. Nicht mit optischen Instrumenten in die Fokussierlines blicken.
4. Nicht über längere Zeit in die Fokussierlines blicken.

ADVARSEL: I dette a apparat anvendes laser.

[Bottom side]

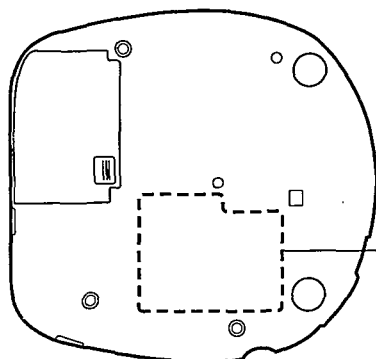

RQLS077-2

CLASS 1 LASER PRODUCT		VARO! Avattaessa ja suojalukitus ohitettaessa olet allttiina näkymätön lasersäteilylle. Älä katso säteeseen.
ADVARSEL: USYNLIG LASERSTRÅLING VED ÅBNING, NÅR SIKKERHEDSAFBRYDERE ER UDE AF FUNKTION. UNDGÅ UDSÆTTELSE FOR STRÅLING.		VARNING! Osynlig laserstråling når denna del är öppnad och spårren är urkopplad. Betrakta ej strålen.
VORSICHT: Unsichtbare Laserstrahlung, wenn Abdeckung geöffnet und Sicherheitsverriegelung überbrückt. Nicht dem Strahl aussetzen.	DANGER: Invisible laser radiation when open and interlock defeated. AVOID DIRECT EXPOSURE TO BEAM.	ADVERSEL! Usynlig laserstråling når deksel åpnes og sikkerheds lås brytes. Unngå eksponering for strålen. RQLS0077-2

Accessories

- AC adaptor 1pc.
 For (EB) area : (RFEA403B-S)
 For (EG) area : (RFEA401E-3S)
 For (GC) area : (RFEA403Z-S)
 For (GN) area : (RFEA403A-S)
 For (GH) area : (RFEA403H-S)
- Stereo headphones (RFEV703P-KS) 1pc.
- Rechargeable battery ass'y 1pcs.
 For (EB,EG) areas : (RFKP3GAVE2S)
 For (GC,GN,GH) areas : (RFKFP3GAT2V)
- Power plug adaptor 1pc.
 For (GC) area : (SJP5213-2)

Location of Controls

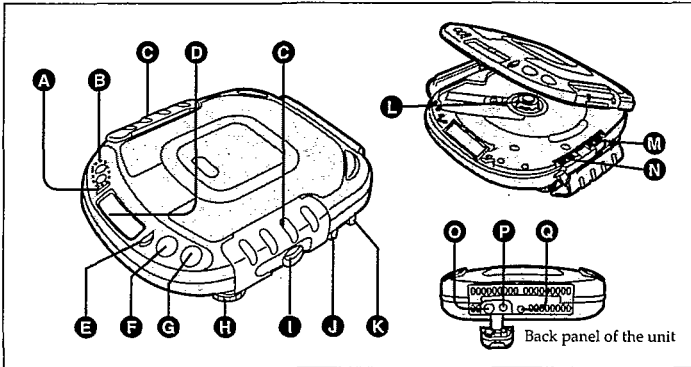

- A Memory/recall button (MEMORY/RECALL)
 - B Skip/search buttons (◀▶, •SKIP/SEARCH)
 - C Dual lock (OPEN)
 - D Display
 - E Repeat button (REPEAT)
 - F Play/pause button (▶||)
 - G Stop/operation off button (■, POWER OFF)
 - H Headphones volume control (VOLUME)
 - I Headphones jack (♯) 16 Ω φ 3.5
 - J Hold switch (HOLD)
 - K XBS/VMSS selector (OFF, XBS, VMSS)
 - L Push button (PUSH)
 - M Play mode selector (MODE)
 - N Extra anti-shock switch (EXTRA ANTI-SHOCK)
 - O Out jack (OUT)
 - P DC in jack (DC IN 4.5 V ⚡)
 - Q Hole for car mounting base
- Set the MODE selector and EXTRA ANTI-SHOCK switch, before inserting the disc.

Power Supply Preparations

Refer to the specifications cover page for information on operating times when using rechargeable batteries or dry-cell batteries.

Using rechargeable batteries

Be sure to recharge the batteries before using them. The unit cannot be used to charge rechargeable batteries other than those specifically designed for it.

For (EB, EG) areas:

- Supplied batteries (RFKFP3GAVE2S)
- Optional batteries (SH-CDB8D)

For (GC, GN, GH) areas:

- Supplied batteries (RFKFP3GAVT2S)
- Optional batteries (SH-CDB8D)

Recharging procedure

1 Open the disc lid.

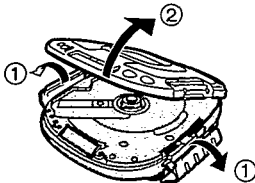

2 Open the battery compartment lid, and place the special rechargeable batteries into the unit.

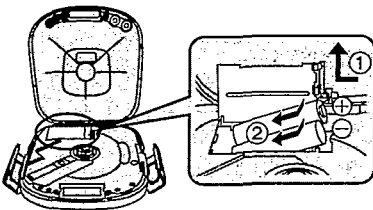

Note

Be absolutely sure to close the battery compartment lid properly to avoid the damage to the disc.

3 Take off the attached rubber cap and connect the AC adaptor.

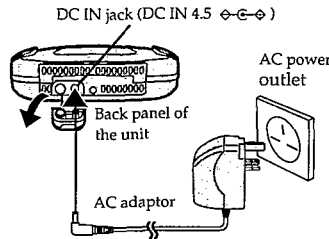

Note

The configuration of the AC adaptor differs according to the area.

4 When recharging is complete, unplug the AC adaptor from the power outlet and the DC IN jack.

Notes

- It takes approximately 5 hours to fully recharge the supplied rechargeable batteries.
- Rechargeable batteries have a service life of approximately 300 charge-discharge cycles. If the operating time on one full charge becomes noticeably shorter than it used to be, the battery has reached the end of its service life and should be replaced.
- You can operate the unit with the AC adaptor while recharging the batteries, but it will lengthen the recharging time.
- The AC adaptor and rechargeable batteries may become warm while recharging is in progress. This is not a malfunction.

If the battery compartment lid comes loose

Insert the protrusions on the lid into the cutouts on both sides of the unit.

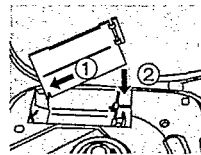

Removing batteries

Push up on the battery in the direction indicated by the arrow. Then lift it out.

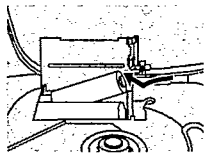

Using dry-cell batteries (not included)

After disconnecting the AC adaptor, insert two LR6 (UM-3) alkaline batteries.

The procedure for inserting and removing dry-cell batteries is identical to that for rechargeable batteries.

Using the AC adaptor

Connect the AC adaptor supplied.

Refer to "Using rechargeable batteries" for connection instructions.

Note

The unit is in the standby condition when the AC adaptor is connected. The primary circuit is always "live" as long as the AC adaptor is connected to an electrical outlet.

Using the car adaptor (not included)

Be sure to obtain the car adaptor (SH-CDC9), available as an optional accessory.

The car adaptor can be used to recharge the unit's batteries while in the car.

Battery indicator

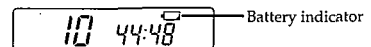

This indicator flashes on and off when the batteries are almost out of power. Power is cut off completely a short while later.

Rechargeable batteries: Recharge batteries.

Dry-cell batteries: Replace batteries with new ones.

Notes

- The length of time the unit will continue to operate after the battery indicator starts flashing depends on the type of batteries used.
- The battery indicator may not flash if rechargeable batteries, other than those designated by Panasonic, are used.

Sequential Play (Basic Play)

1 Label must face upward.

2 Close the lid.

3 HOLD →

4 In step 4, connect the plug of the headphones to the "R" jack, and insert it securely all the way until you hear the second click.

Note
When opening the dual lock, make sure the headphones plug is not facing in the direction as shown in the illustration. The headphones plug can be damaged by catching on the dual lock.

5 Track number in play: 1
Elapsed playing time of each track: 0:01

6 VOLUME

Following steps 1-6.

- Play stops automatically when all the tracks have been played.
- If the unit has been connected to the car audio system, adjust the volume level between 4 and 6 on the unit, then adjust the volume level on the system.

For your reference:

- "no disc" indication**
This indication appears for about 30 seconds if the ►|| button is pressed when no disc is loaded in the unit or if the disc is not completely seated.
- "OPEN" indication**
This indication appears for about 10 minutes when the cover is opened. (However, the indication does not appear when the unit is powered off.)

Auto power off function

If the unit is left in stop or paused status for approximately 10 minutes, the unit powers itself off automatically in order to prevent the batteries from running down.

Removing discs

After the disc has stopped rotating, press the PUSH button to release the disc. (To protect the disc, never open the cover while it is playing.)

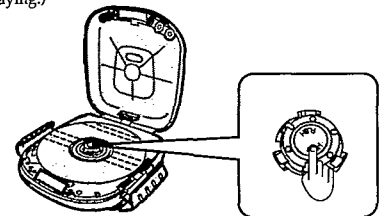

Note

Never insert foreign objects into the unit body.

This unit is not designed to be under water.
Before operating the unit please read the section on "Water Resistant (Splash Proof)" (page 6) for details.

Operation	Button	Display/reference
To pause play	Press during play 	 Press again to resume play
To stop play Stop mode	Press during play POWER OFF 	Total number of tracks Total playing time
To turn off the unit Off mode	Press during stop mode POWER OFF 	
Skip forward/ backward (skip function)	Press during play 	<ul style="list-style-type: none"> • During program play (see page 4), these buttons are used to skip forward or back through the programmed sequence of tracks. • During random play (see page 4), the skip buttons cannot be used to skip back to tracks that were played previously in the random sequence. • During program play, random play or 1 track repeat play (see page 4), search operation is limited to the current track only.
Rapid forward/ backward (search function)	 Backward Forward Keep depressed during play	

Other Play Methods

The letters such as **A** in the various illustrations refer to the descriptions in the "Location of Controls" section. (See page 3.)

Skip play

The disc plays from the specific track through to the last track, then play stops automatically.

Preparation: Put unit in stop mode. (See page 3.)



2 Select the desired track.



Program play

Up to 24 tracks can be entered in the programmed sequence.

Preparation: Put unit in stop mode. (See page 3.)



2 Select the desired track.



3 Register in sequence.
(The indication "M" and the programmed sequence appear on the display panel.)

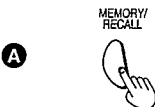

4 Repeat steps 2 and 3 to program all the desired tracks.

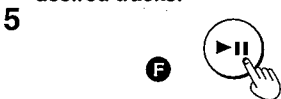

■ To program the same track in the sequence more than once

After step 3, press MEMORY/RECALL the desired number of times.

■ If "F" is displayed

No more tracks may be added to the sequence.

■ To confirm the contents of the programmed sequence

Press MEMORY/RECALL while the disc is playing. (The number of the programmed tracks appear on the display panel in sequence.)

■ To delete the entire programmed sequence

Press ■, POWER OFF.

Random play

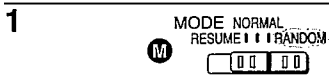

Release



For your reference:

- It is also possible to press the ►► button while the unit is in stop status to change the first track to be played. (All tracks are played eventually, regardless of which is played first.)
- Program play is not possible in the random mode.

Resume play

This function allows you to listen from the beginning of the track where play stopped because the unit was powered off (or switched to stop status). It is useful when listening to CDs in the car, etc.

Release

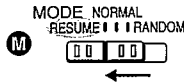

For your reference:

- If the MODE (play mode) slider is put in the RESUME position, the all-repeat function will be activated automatically as soon as the unit is powered on.
- If power is cut off near the end of a track (power off status), playback may resume from the beginning to the next track in some cases.
- If the unit is powered off while a disc was playing and then a new disc is inserted, play will begin from the middle of the new disc because the unit remembers the position where play stopped on the previous disc.

Repeat function

Press REPEAT while disc is playing or when unit is in stop status.

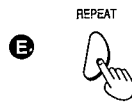

The setting is switched in the sequence indicated below each time REPEAT is pressed.

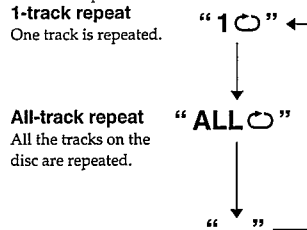

For your reference:

If REPEAT is pressed during program play, only the tracks in the programmed sequence are repeated. (The indication "ALL" is not displayed.)

Changing the sound quality

(Available except when using the OUT jack)

XBS:
Select this setting to boost the low-range response.

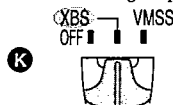

VMSS:

Boosts the low frequency range. Also, the vibration of the earpieces of the included headphones makes sound vigorous. Raising the volume level makes the VMSS effect intensify.

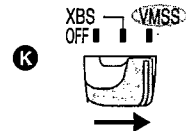

OFF:

Select this setting to turn off the XBS and VMSS functions.

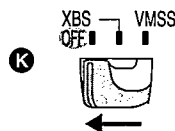

Note

VMSS may not be effective depending on the source.

Using the Unit with Optional Accessories

Using the unit with an audio system

Using the stereo connection cable (not included), you can listen to CDs through your audio system.

- Connect the cable to the amplifier after turning off its power.
- Do not connect the cable to the PHONO jacks on the amplifier.
- Obtain the optional connecting cable if the amplifier comes with mini-phone jacks.
- Adjust the volume level on the amplifier.

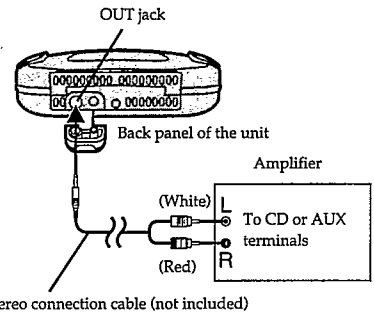

Using the unit with a car audio system

Items to be purchased

For connection to the car audio system:

- Car adaptor (SH-CDC9)
- Car stereo cassette adaptor (SH-CDM9A/SH-CDM10A)

Connect the car stereo cassette adaptor to the unit's headphone jack. (When doing this, keep the unit's VOLUME control at a setting between 4 and 6.)

For securing the unit:

- Car mounting kit (SH-CDF20)

Note

It may not be possible to use the unit with some types of car stereo owing to restrictions imposed by the construction of the car stereo cassette adaptor.

For further details, refer to the instructions of the part concerned.

Extra Anti-Shock Function

This function minimizes sound interruption when vibrations are encountered by utilizing audio data that has been stored ahead of time (up to approximately 10 seconds' worth).

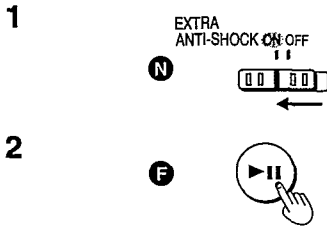

M.RESERVE indicator status	Unit body status	Play status (audio data status)
	Stable	Normal (plenty of data is stored)
	Bump encountered	Normal (stored data is used)
	Bumping stops	Normal (data again starts to be stored)
	Bumps continue repeatedly	Sound is interrupted (data buffer empty)

Notes

- The EXTRA ANTI-SHOCK control cannot be set while play is in progress. Stop play, open the cover and then select the setting for this control.
- During extra anti-shock operation, the disc rotates at a higher rate than usual in order to collect extra audio data. This may cause the batteries to run out faster and could result in a slight increase in disc rotation noise.

Using the unit with an audio system

The extra anti-shock uses digital signal compression technology. It is recommended that the extra anti-shock be kept in the OFF position if the unit is connected to a home audio system.

Accidental Operation Prevention

Function

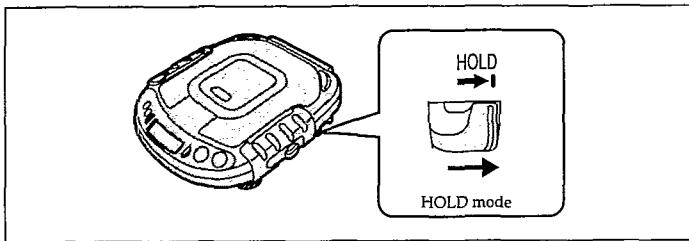

This function causes the unit to ignore short, accidental button presses. (The disc lid can still be opened and closed.)

The misoperation prevention function prevents the following:

- Powering on the unit accidentally (which can cause the batteries to go dead).
- Play being cut off unexpectedly in the middle of a selection.

To use the accidental operation prevention function

Set HOLD switch to the HOLD mode.

"hold" indication

When the unit is in HOLD status, pressing any operation button causes the indication "hold" to appear on the display.

When the unit is powered off

The "hold" indication appears only when the play/pause button is pressed.

Be sure to cover the headphones jack. OUT jack and DC IN jack with attached rubber cap when these jacks are not in use.



Side panel of the unit

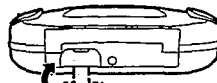

Back panel of the unit

Troubleshooting Guide

Before requesting service for this unit, check the chart below for a possible cause of the problem you are experiencing. Some simple checks or a minor adjustment on your part may eliminate the problem and restore proper operation.

If you are in doubt about some of the check points, or if the remedies indicated in the chart do not solve the problem, refer to the directory of Authorized Service Centers (enclosed with this unit) to locate a convenient service center, or consult your dealer for instructions.

Problem	Check this
Cannot close cover.	Is the disc properly secured in place?
Cannot play discs.	<ul style="list-style-type: none"> •Is the unit in HOLD status? •Is the disc properly secured in place? •Is there moisture condensation on the lens? (Wait for about an hour and then try again.)
Cannot remove disc.	Did you press the PUSH button to release the disc?
Tracks on disk do not play in order, starting with the first track.	Is the MODE (play mode) slider in the NORMAL position?
Cannot hear music—too noisy.	<ul style="list-style-type: none"> •Is the headphones plug inserted all the way? •Is the plug dirty? (Wipe away dirt on the plug.)
TV picture is distorted. Radio reception is noisy.	Are you using the unit body too near a TV or tuner? (If the TV or tuner is connected to a simple indoor antenna, connect it to an outdoor antenna.)

Maintenance

Maintaining the unit

Wipe the unit with a soft cloth. Remove stubborn dirt using a cloth which has been dipped in water or soapy water and wrung out, and then wipe dry.

- If you intend to use a chemically treated cleaning cloth, read its directions first.
- Do not use alcohol or paint thinners.

Maintaining the lens

Open the lid and clean the lens as shown in the figure. Use a cotton swab to gently wipe off any finger-prints. Recommended product: Lens cleaner kit (SZZP1038C)

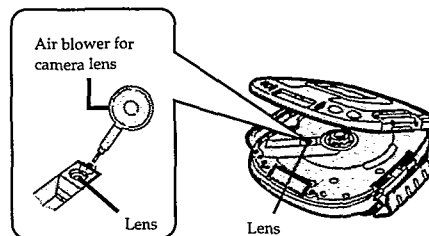

Cautions

Water Resistant (Splash Proof)

This unit is splash-proof and is not designed to be used under water.

Please note the following points to avoid possible damage to the unit and the included headphones.

- Do not drop them into water and dash much water.
- Since water in the headphones jack, OUT jack and DC IN jack may cause damage, cover it properly with attached rubber cap when these jacks are not in use.
- To prevent water from entering the unit dual locks should be locked to close the disc lid.
- If the unit or the headphones get wet with water or sweat, dry them with a soft cloth.
- Do not open the disc lid near water or sand. Before opening or closing the disc lid, be sure to wipe off water, dust or sand on the unit and operate with a dry hand.
- Make sure of no sand and dust around the disc lid. If there is sand or dust, the disc lid will not close properly and water will get into, which may cause a trouble.
- Do not expose the unit or the headphones to salt water. If the unit and headphones are immersed in salt water, wash them in a little fresh water then dry with soft cloth. Never wash them under running water.
- Do not place the unit and the headphones for a long period of time in high temperature and high humidity area such as bathrooms or damp basements, etc.

Rechargeable batteries

- For (EB, EG) areas:
Only the RFKFP3GAVE2S, SH-CDB8D batteries can be recharged.
- For (GC, GN, GH) areas:
Only the RFKFP3GAVT2S, SH-CDB8D batteries can be recharged.
- If the power delivered by the batteries lasts for a very short time after recharging, it means that the batteries' service life is over. Do not use them any more.
- Recharging already charged batteries will shorten their service life.
- When recharging batteries for the first time or when they have not been used for a long period of time, the play time may be shorter than usual. In a case like this, repeatedly recharge and discharge the batteries. This will restore them to their regular state.
- Do not allow any metal objects to touch the terminals of rechargeable batteries since this may cause short-circuiting which is dangerous.
- Do not peel off the plastic covering on the rechargeable batteries. Short-circuiting may occur which is dangerous.

Dry cell batteries/rechargeable batteries

To prevent damage to the batteries and electrolyte leakage, heed the following points.

- Align the ⊕ and ⊖ polarities properly when inserting the batteries.
- Do not mix different types or makes of batteries or old and new batteries.
- Remove the batteries if you do not plan to use the unit for a long period of time.
- Do not throw batteries into a fire, and do not short-circuit, disassemble or subject them to excessive heat.
- Do not attempt to recharge dry cell batteries.

Carrying dry cell batteries/rechargeable batteries around

When putting dry cell or rechargeable batteries in a pocket or bag, ensure that no other metal objects such as a necklace are placed together with them. Contact with metal may cause short-circuiting which, in turn, may cause a fire.

Be absolutely sure to carry the rechargeable batteries in the battery carrying case.

When purchasing rechargeable batteries

As a safety precaution, the portable CD players made by Panasonic have a construction designed to make it impossible to recharge ordinary batteries.

To use rechargeable batteries, be absolutely sure to purchase the rechargeable Ni-Cd batteries designed especially for this unit.

Special rechargeable Ni-Cd batteries:

For (EB, EG) areas:
RFKFP3GAVE2S, SH-CDB8D (set of 2)

For (GC, GN, GH) areas:
RFKFP3GAVT2S, SH-CDB8D (set of 2)

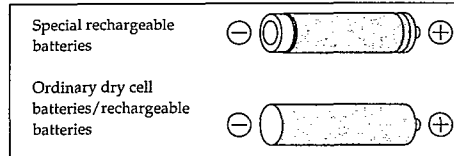

(For United Kingdom)

Notice about the rechargeable battery
The battery is designated recyclable.
Please follow your local recycling regulations.

When driving a car

In the interest of traffic safety, do not operate the unit while driving.

AC adaptor

- Handle the AC adaptor carefully. Improper handling is dangerous.
 - Do not touch it with wet hands.
 - Do not place heavy objects on top of it.
 - Do not forcibly bend it.
- Be sure to connect only the AC adaptor provided with the unit.
- Disconnect the AC adaptor from the power outlet if the unit is not going to be used for a long time.

Unit

No altering or remodeling

This can cause malfunctioning.

No dropping or strong impacts

This may damage the unit.

Locations to be avoided

Avoid using the unit in the following locations since they can cause malfunctioning.

1. Bathrooms and other moisture-prone places.
2. Warehouses and other dusty places
3. Very hot places near heating appliances, etc.

Do not leave the unit exposed to direct sunlight for long periods of time

This may deform or discolor the cabinet and may also cause malfunctioning.

Precautions for Listening with the Headphones

- Do not play your headset at a high volume. Hearing experts advise against continuous extended play.
- If you experience a ringing in your ears, reduce volume or discontinue use.
- Do not use while operating a motorized vehicle. It may create traffic hazard and is illegal in many areas.
- You should use extreme caution or temporarily discontinue use in potentially hazardous situations.
- Even if your headphones is an open-air type designed to let you hear outside sounds, don't turn up the volume so high that you can't hear what's around you.

Concerning compact Discs

Only compact discs bearing this mark can be used with this unit.



However, continued use of irregular shape CDs (heart-shape, octagonal, etc.) can damage the unit.



How to remove a disc from its case

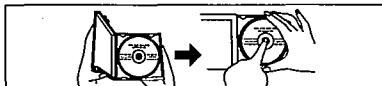

How to store the disc in its case

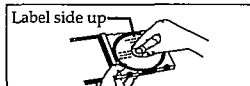

How to hold a disc

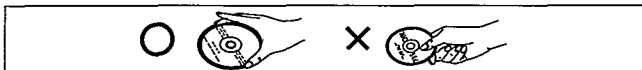

If the surface is dirty

Wipe it with a damp cloth and then wipe dry.

Wipe from the center toward the outer circumference.

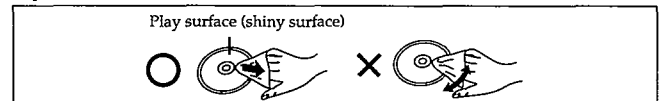

If moisture has formed on a disc

When moisture has formed because the disc was brought suddenly into a warm room from a cold environment, wipe it off using a soft dry cloth.

When storing discs

Avoid locations which are

- Exposed to direct sunlight.
- Susceptible to high levels of humidity or dust.
- Directly exposed to heat from a heating appliance.
- On top of a car dashboard or near the rear window.

Handling precautions

- On the label side (the side with writing)
 - Do not write anything using a pencil, ball-point pen, etc. Do not stick ON paper or labels.
- On the disc (shiny) side
 - Handle this side carefully to keep it free from fingerprints or scratches. Do not use record cleaners, solvents, etc.
- Do not attach labels or stickers to CD's. Do not use CDs with exposed adhesive from tape or left over peeled off stickers.
- Do not use scratch-proof protectors or covers other than those specified for use with this unit.

■ Handling Precautions for Traverse Deck

The laser diode in the traverse deck (optical pickup) may break down due to potential difference caused by static electricity of clothes or human body.

So, be careful of electrostatic breakdown during repair of the traverse deck (optical pickup).

● Handling of traverse deck (optical pickup)

1. Do not subject the traverse deck (optical pickup) to static electricity as it is extremely sensitive to electrical shock.
2. The short land between the No. ⑫ (LD GND) and No. ⑬ (LD) pins on the flexible board (FFC) is shorted with a solder build-up to prevent damage to the laser diode. To connect to the PC board, be sure to open by removing the solder build-up, and finish the work quickly.
3. Take care not to apply excessive stress to the flexible board (FFC).
4. Do not turn the variable resistor (laser power adjustment). It has already been adjusted.

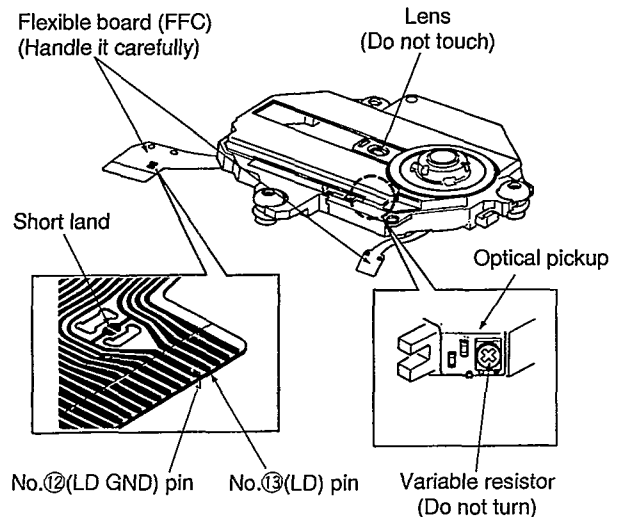

● Grounding for electrostatic breakdown prevention

1. **Human body grounding**
Use the anti-static wrist strap to discharge the static electricity from your body.
2. **Work table grounding**
Put a conductive material (sheet) or steel sheet on the area where the optical pickup is placed, and ground the sheet.

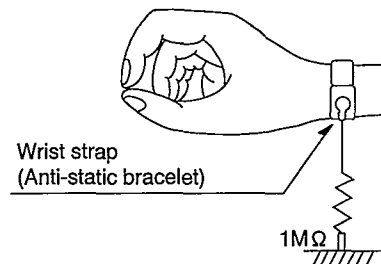

Caution:

The static electricity of your clothes will not be grounded through the wrist strap. So, take care not to let your clothes touch the traverse deck (optical pickup).

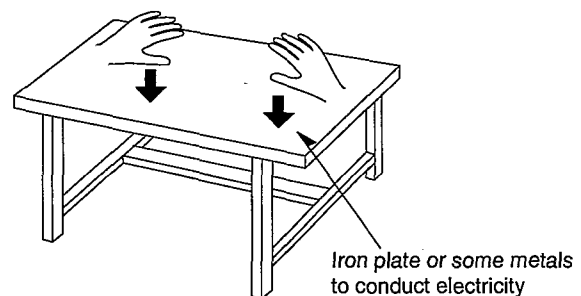

■ Operation Checks and Main Component Replacement Procedures

NOTE

1. This section describes procedures for checking the operation of the major printed circuit boards and replacing the main components.
2. For reassembly after operation checks or replacement, reverse the respective procedures. Special reassembly procedures are described only when required.
3. [] indicates parts No.

1. Checking for the P.C.B. (Component side)

Step 1

Release the buckle, and then open the CD cover ass'y.

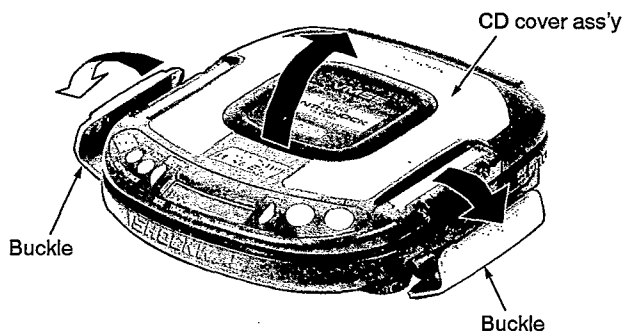

Step 3

Open the battery cover.

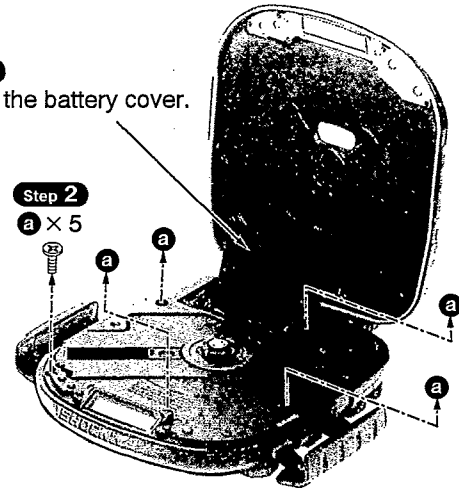

Step 2

a x 5

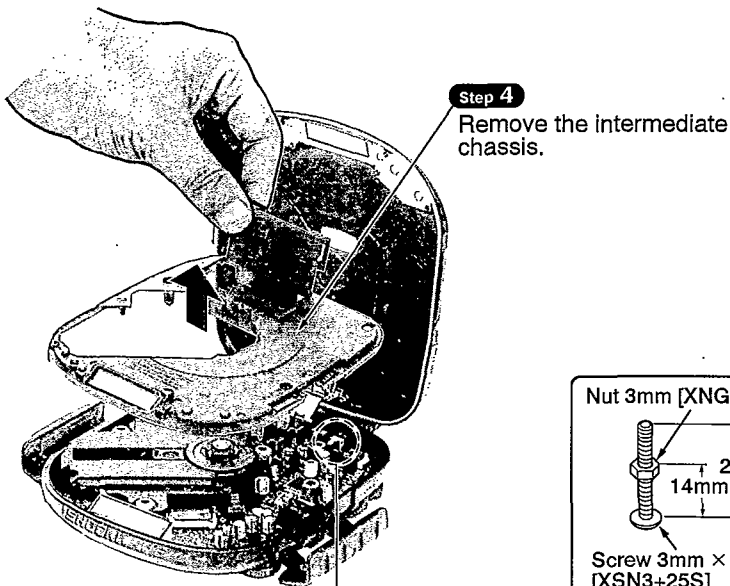

Nut 3mm [XNG3ES]

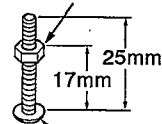

Screw 3mm x 25mm [XSN3+25S]

Nut 3mm [XNG3ES]

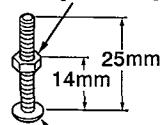

Screw 3mm x 25mm [XSN3+25S]

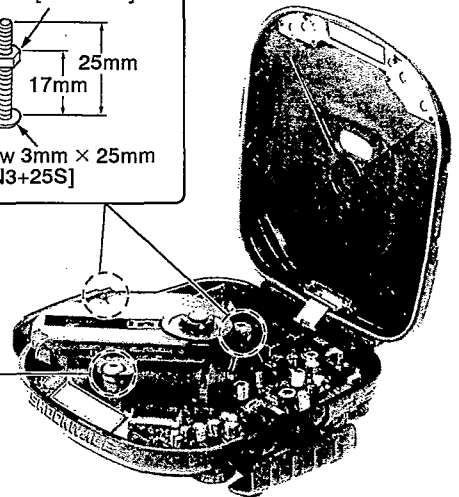

Step 5

Open the water proof cover (B).

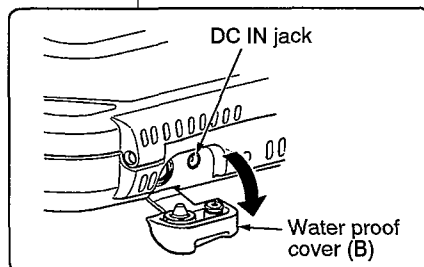

Step 6

Sustain the traverse deck with the floating rubber inserted screws and nuts as shown above.

NOTE

- The tip of screw must not protrude above the floating rubber.
- To keep insulation, place the insulator sheet (paper etc.) between the P.C.B. and the head of screws.

• Check the P.C.B. (Component side) as shown below.

NOTE

After checking, unsolder the short land to open circuit.

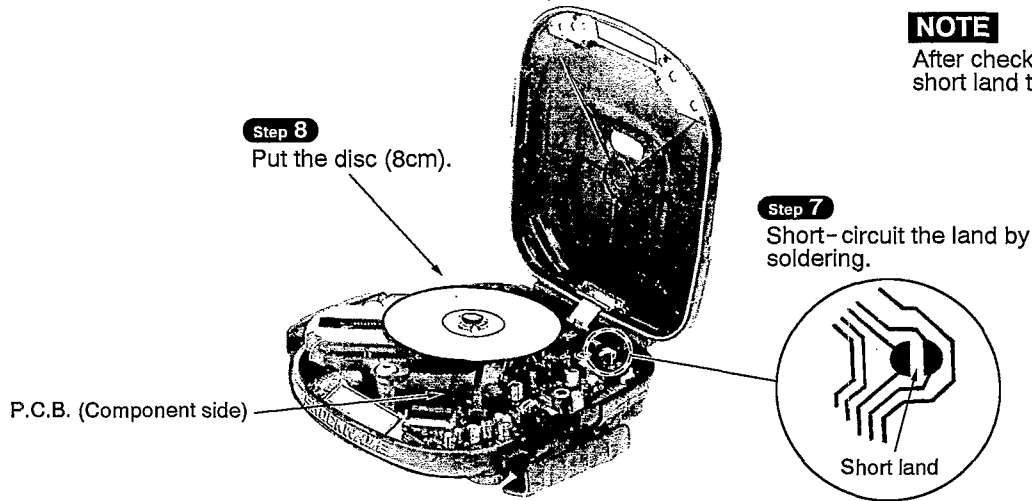

2. Checking for the P.C.B. (Solder side)

• Follow the **Step 1** ~ **Step 5** in item 1 on page 9.

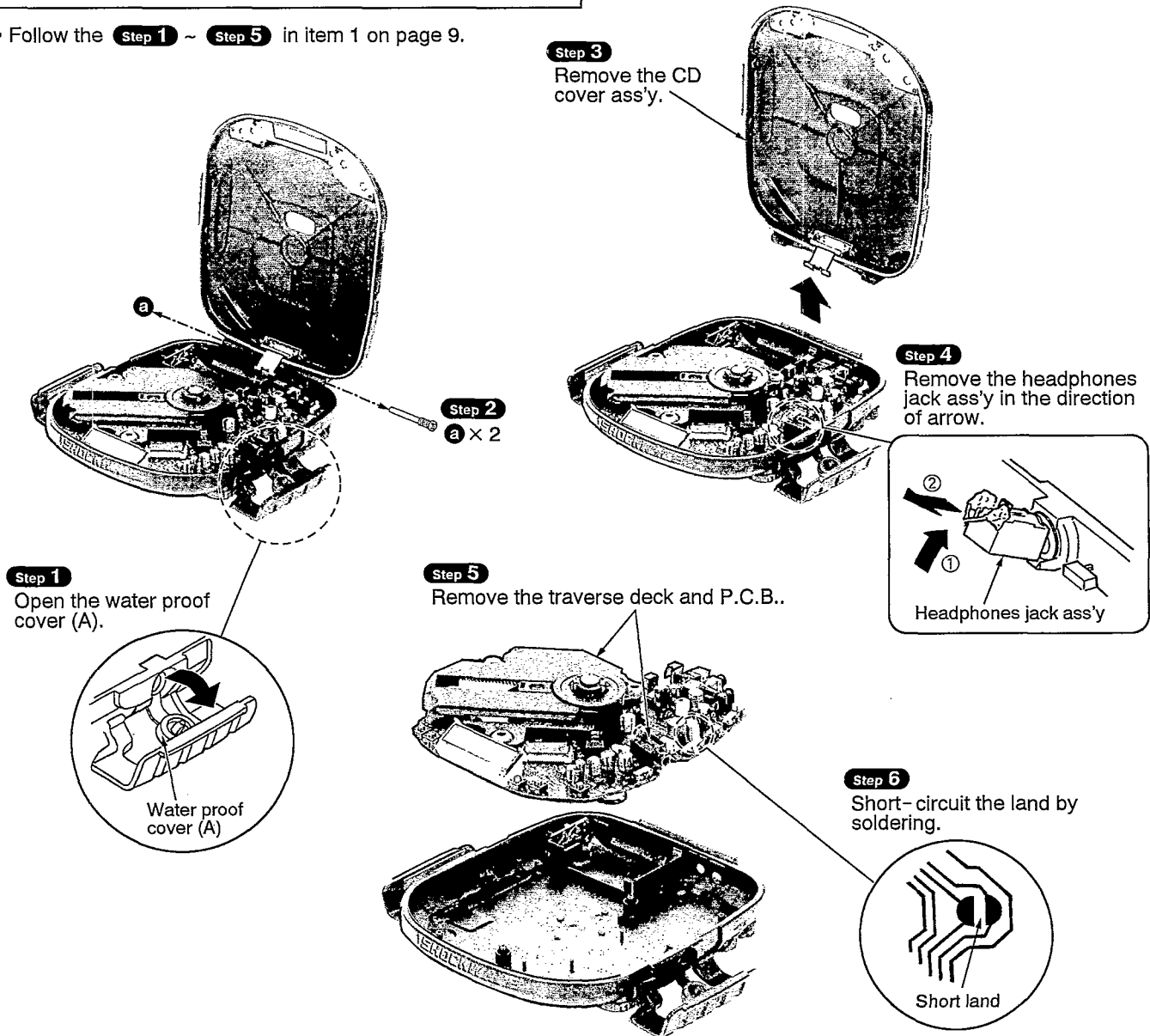

Traverse deck and P.C.B.

Step 7

Align the bosses of intermediate chassis with the floating rubber of traverse deck ass'y.

• Check the P.C.B. (Solder side) as shown below.

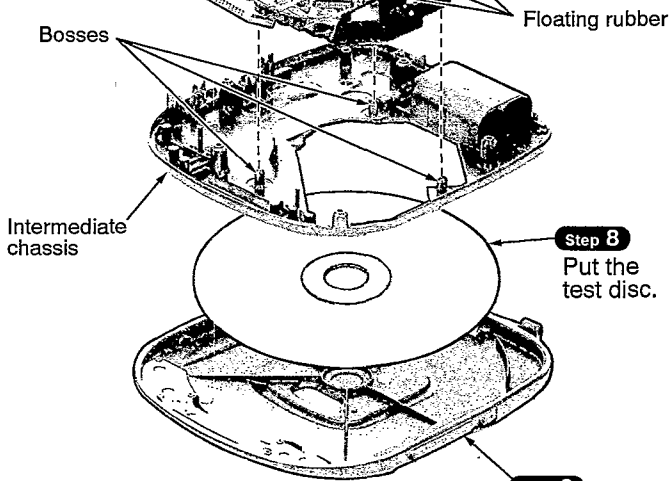

Step 8

Put the test disc.

Step 9

Locate the items on the CD cover ass'y.

Step 10

Connect the AC adaptor to the DC IN jack, and then apply DC power.

P.C.B. (Solder side)

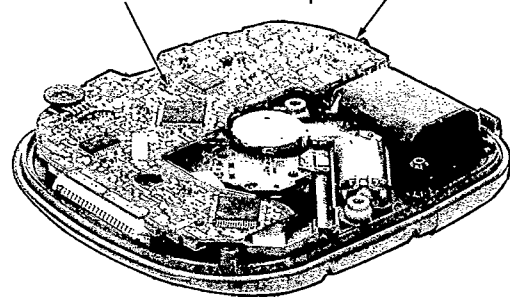

NOTE

After checking, unsolder the short land to open circuit.

Notice for Installation

1. Installing the P.C.B. to the bottom cabinet ass'y.

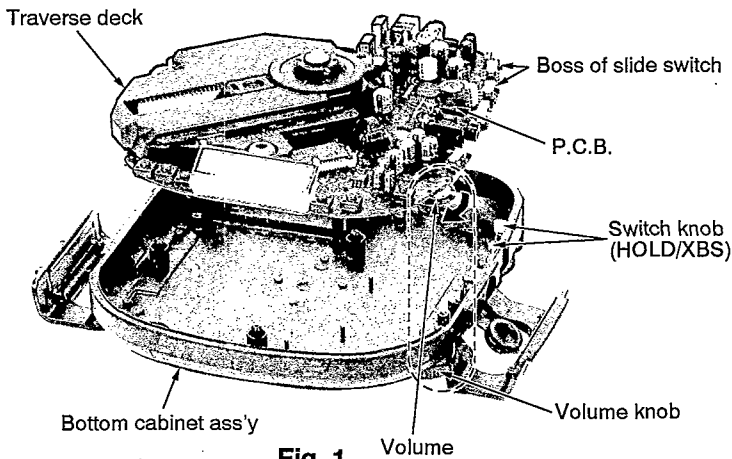
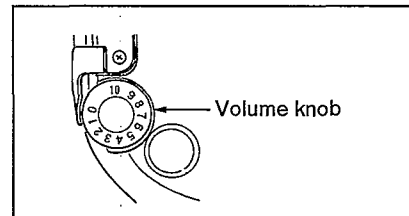

Fig. 1

- A. Align the boss of slide switch with switch knob (See Fig 1).
- B. 1) Rotate the volume knob fully in the direction of arrow.
2) Set the marking "0" on volume knob to the position as shown below.



- 3) Align the boss of volume lever with slot of volume knob as shown below.

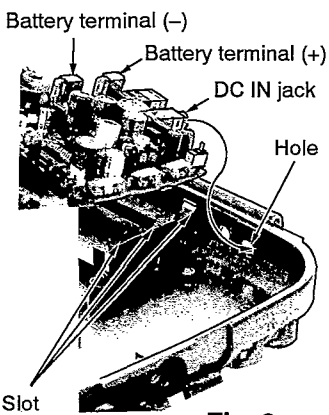
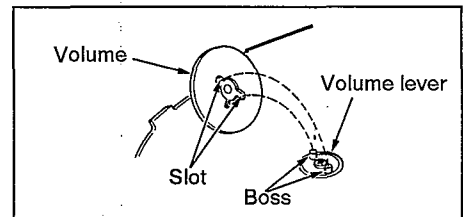

Fig. 2

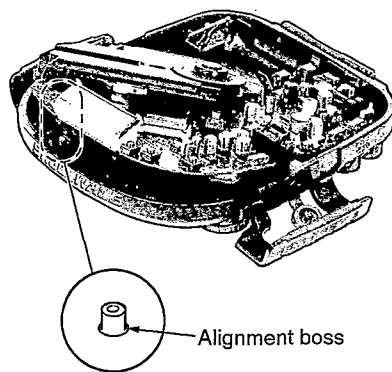
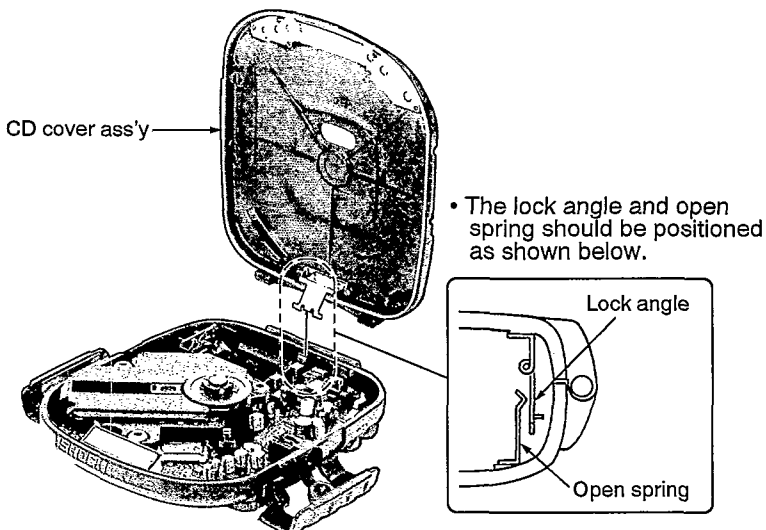

Fig. 3

- C. Put the DC IN jack into the hole of bottom cabinet ass'y (See Fig 2).
- D. Align the battery terminals (+) and (-) with slot of bottom cabinet ass'y (See Fig 2).
- E. Be sure to locate the P.C.B. on the alignment boss. (See Fig 3).

2. Installing the CD cover ass'y.



3. Installing the intermediate chassis.

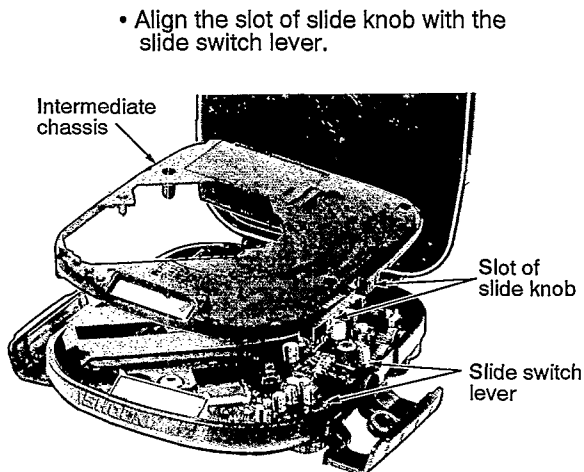

3. Replacement for the traverse deck

Follow the **Step 1** ~ **Step 4** in item 1 on page 9.

Step 1

Pull out the FFC from connector (CN101).

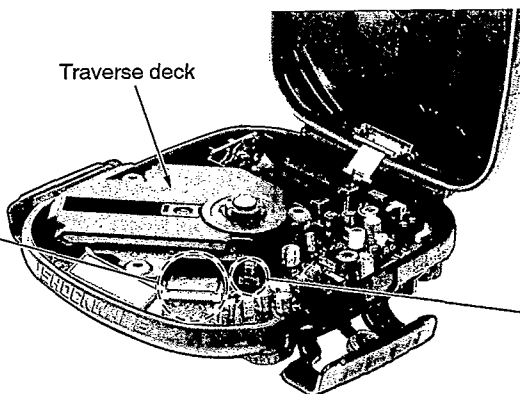
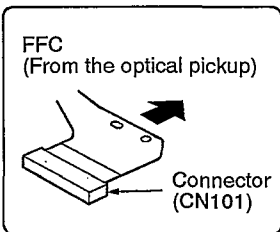

Step 2

Pull out the FFC from connector (CN102).

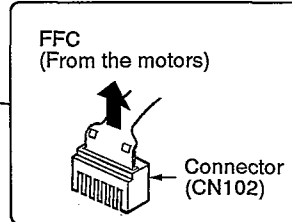

NOTE

Solder the point between pin ⑫ (LD GND) and pin ⑬ (LD) of FFC board. (Refer to "Handling Precautions for Traverse Deck" on page 8.)

4. Replacement for the CD cover ass'y

Follow the **Step 1** ~ **Step 4** in item 1 on page 9.

Follow the **Step 1** ~ **Step 3** in item 2 on page 10.

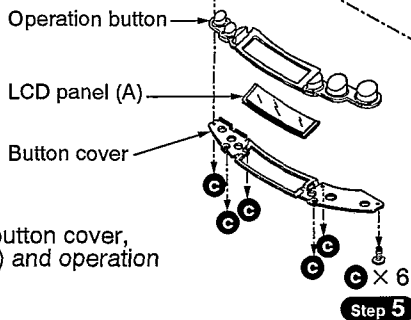

Step 1

$a \times 4$

Step 2

Remove the buckle ornament (A) and buckle ornament (B).

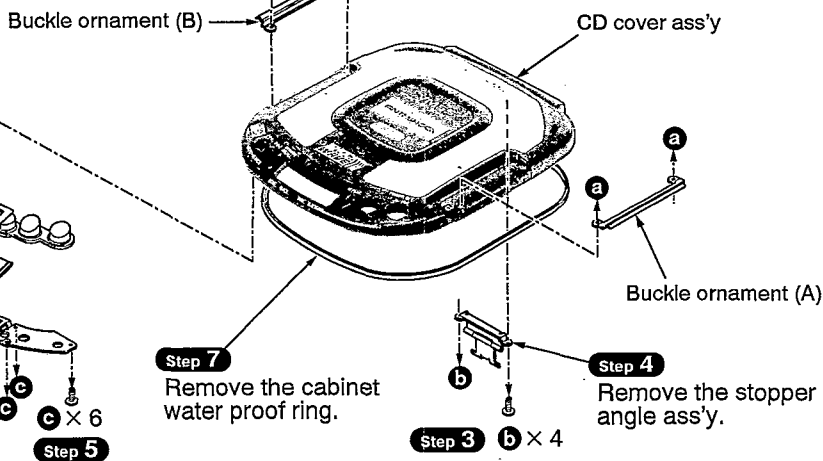

■ Checking the Operation Problems on the Traverse Deck (Optical Pickup)

Make sure to follow the procedures below to check the operation problems of the traverse deck (optical pickup) before replacing it. Replace the traverse deck only after the problem is identified.

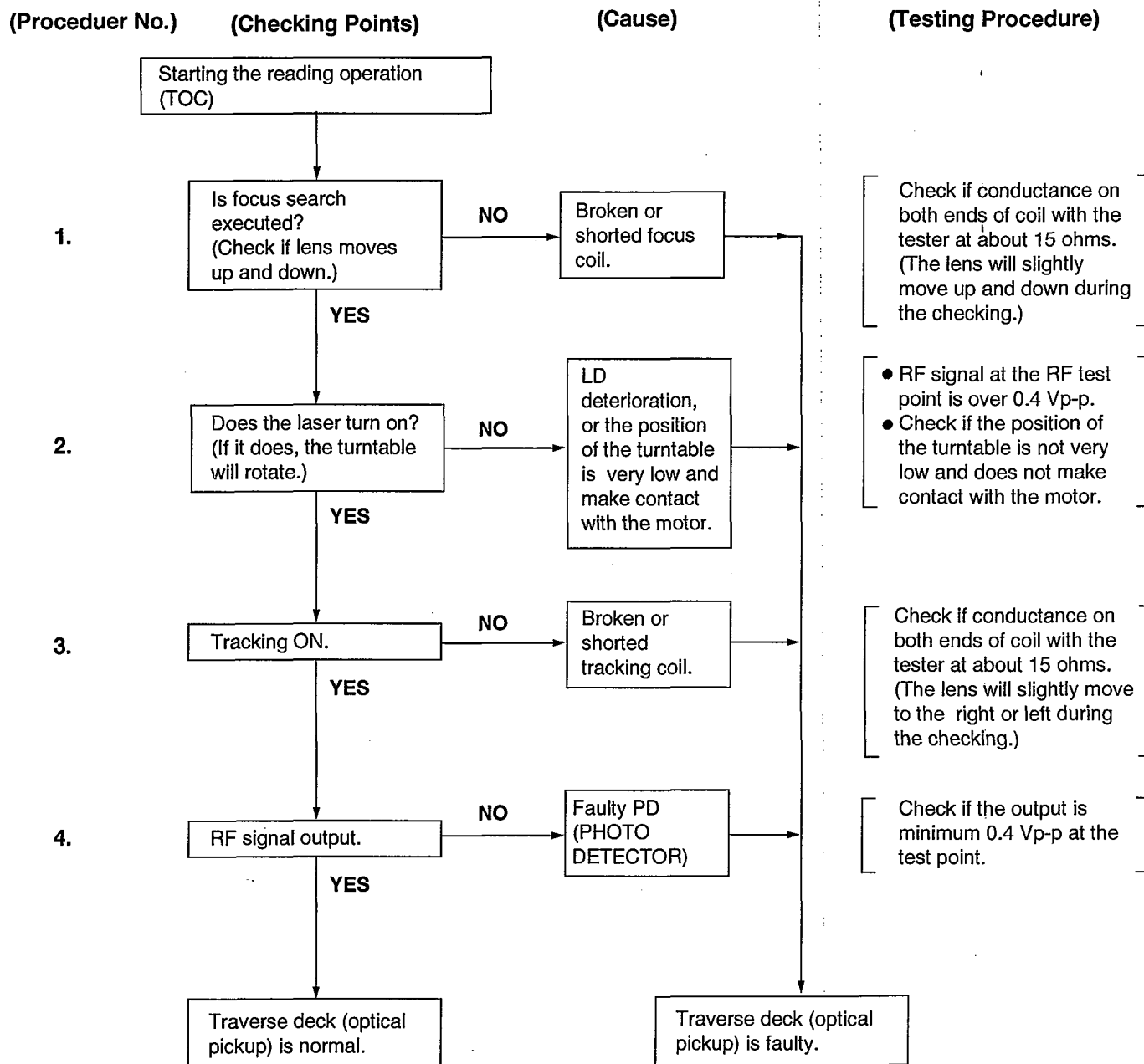

※ Replace the traverse deck.

- Check electrical circuit.
- Check for flaws on disc or if it is warped or not centered.

● Check the operations described below on the traverse deck after replacing it.

* Checking Skip Search

1. Play an ordinary musical program disc.
2. Press the skip button to check for normal skip search operation (in both the forward and reverse directions).

* Checking Manual Search

1. Play an ordinary musical program disc.
2. Press the manual search button to check for smooth manual search operations at either low or high speed (in both the forward and reverse directions).

* Checking Playability

1. Play the 0.7 mm black dot and the 0.7 mm wedge on the playability test disc (SZZP1054C) and verify that no sound skip or noise occurs.
2. Play the middle tracks of the uneven test disc (SZZP1056C) and verify that no sound skip or noise occurs.

Automatic Adjustment Results Display Function (Self-check Function)

On this unit (SL-SW415), each automatic adjustment result are displayed on the LCD. This function is convenient to check or identify which automatic adjustment circuit is incorrect. The followings are the contents of the automatic adjustment result displays (self-check function).

How to display automatic adjustment results

1. Load the test disc (SZZP1054C).
2. Press the **⏮** (SKIP/SEARCH) and **⏭** (SKIP/SEARCH) Buttons simultaneously and hold them, and additionally press the **▶/⏸** (PLAY/PAUSE) Button.
3. Press the **■** (STOP/POWER OFF) Button once.
4. An automatic adjustment result is displayed on the LCD.

Display of automatic adjustment results (self-check function)

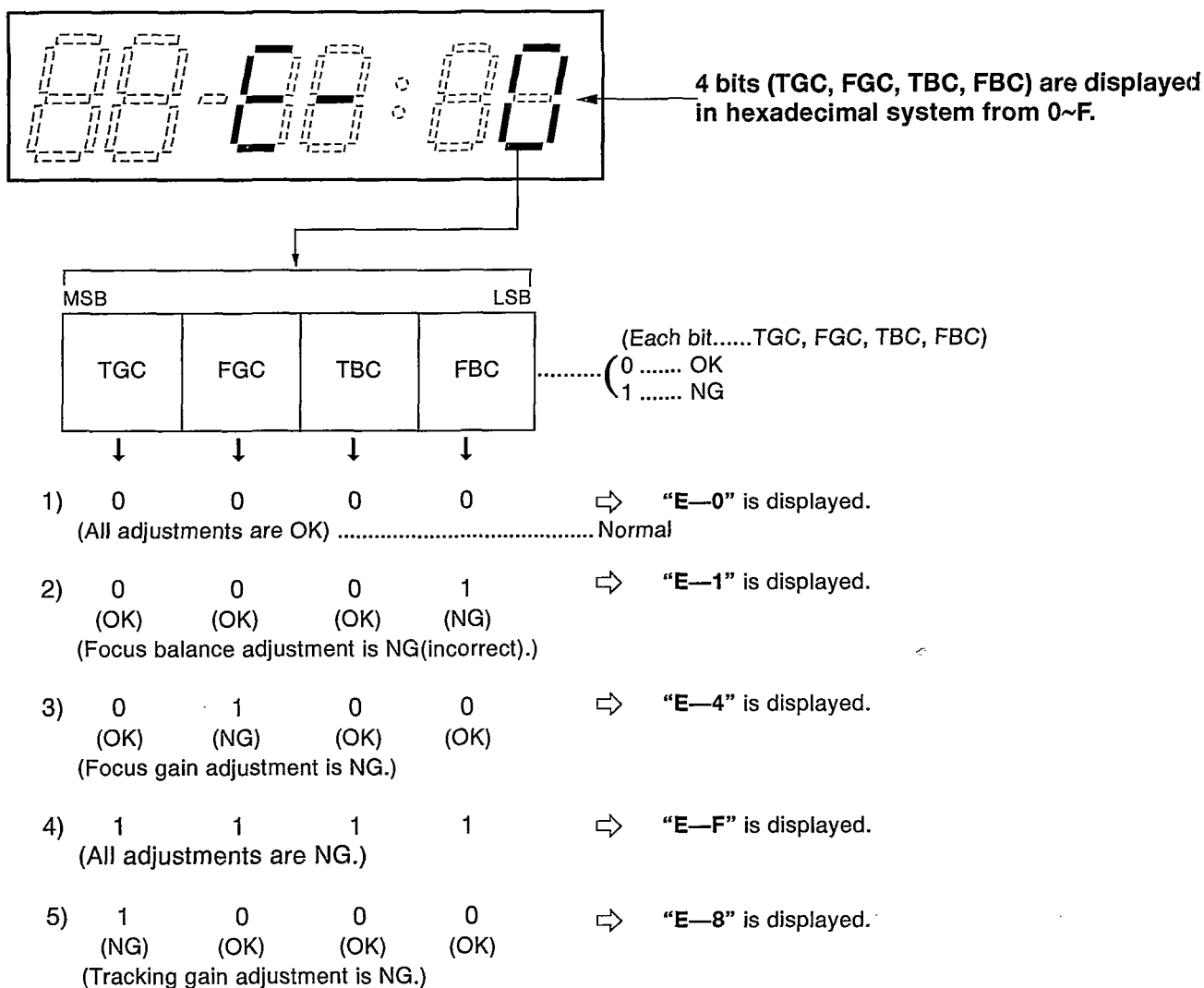

Note: If any other disc than the test disc (SZZP1054C) is used, an "E—8" may be displayed.

〈Example〉 **Follow the below steps when “E—1” is displayed.**

(Cause: Focus balance (FBC) is set beyond the limit.)

● Check if

- (1) the waveform or voltage of the focus servo circuit is correct.
- (2) the optical pickup returns to the normal state by exchanging the traverse deck.

Follow the below steps when “E — 4” is displayed.

(Cause: Focus gain (FGC) is set beyond the limit.)

● Check if

- (1) the waveform or voltage of the focus servo circuit is correct.
- (2) the focus coil of the optical pickup is correct (around 15 ohms).
- (3) the optical pickup returns to the normal state by exchanging the traverse deck.

Follow the below steps when “E — F” is displayed.

(Cause : All adjustments (TGC, FGC, TBC, FBC) are set beyond the limit.)

● Check if

- (1) the optical pickup returns to the normal state by exchanging the traverse deck.
- (2) the waveform or voltage of the servo IC's (IC101, 501) are correct.

Note:

It is not always necessary to exchange the traverse deck when an error message is displayed. Be sure to check if the circuit is defective or not before exchanging the traverse deck.

Note:

If any other disc than the test disc (SZZP1054C) is used, an error message may be displayed. This is not a malfunction.

■ Measurements and Adjustments

Warning: This product uses a laser diode. Refer to caution statements on page 2.

ACHTUNG: ● Die lasereinheit nicht zerlegen.

● Die lasereinheit darf nur gegen eine vom hersteller.spezifizierte einheit ausgetauscht werden.

● Measuring instruments and special tools

● Test discs

1. Playability test disc (SZZP1054C)
2. Uneven test disc (SZZP1056C)

● Musical program disc (ordinary)

- DC voltmeter
- Lead wire (for test points)

● Test short land

Short-circuit the lands of the laser ON/OFF switch (S201) by soldering them. It turns “ON” position. (Refer to below **Fig. 1** or printed circuit board and wiring connection diagram for short land location on page 26.)

Note: Remove the solders from the lands after adjustment.

● Adjustment point

Notes: 1. Please refer to the printed circuit board and wiring connection diagram for test point locations on page 26.

2. Take care to connect CN101 and CN102, as shown in **Fig.1**.

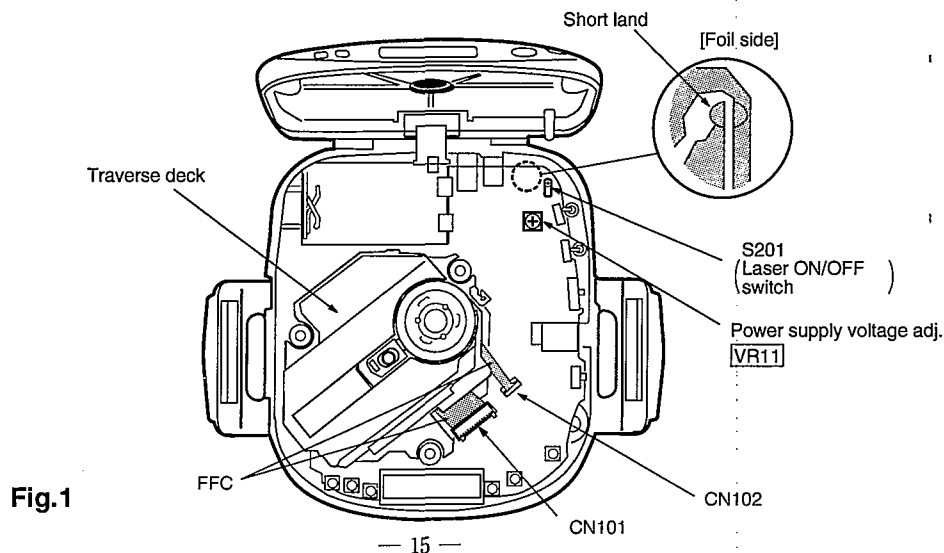

Fig.1

(1) POWER SUPPLY VOLTAGE ADJUSTMENT

1. Connect the DC voltmeter to **TP103** (VCC) (+) and **TP104** (GND) on the P.C.B.
2. Connect the AC adaptor cord to the DC (IN) port and move the PLAY switch to the ON position.
(Use a new dry cell battery or a rechargeable battery that is full charged.)
3. Insert the test disc, and switch the player power ON.
4. Adjust **VR11** on the P.C.B. at **3.10 ~ 3.14 V**, as shown in Fig. 1.

(2) CHECK OF PLAY OPERATION

*** Checking Skip Search**

1. Play an ordinary musical program disc.
2. Press the skip button to check for normal skip search operation (in both the forward and backward directions).

*** Checking Manual Search**

1. Play an ordinary musical program disc.
2. Press the manual search button to check for smooth manual search operations at either low or high speed (in both the forward and backward directions).

*** Checking Playability**

1. Play the 0.7 mm black dot and the 0.7 mm wedge on the playability test disc (SZZP1054C) and verify that no sound skip or noise occurs.
2. Play the middle tracks of the uneven test disc (SZZP1056C) and verify that no sound skip or noise occurs.

• Automatic adjustment

On our conventional type portable CD player, there were mounted 6 semi-fixed controls for each adjustment. Since the SL-SW415 servo circuit is equipped with an automatic adjusting circuit, these controls are removed from SL-SW415.

On conventional portable CD player
Use for Old Servo IC (AN8373SE2, AN8374SE2)

1. Tracking Offset Adjustment VR (TOC)
2. Focus Offset Adjustment VR (FOC)
3. Tracking Gain Adjustment VR (TGC)
4. Focus Gain Adjustment VR (FGC)
5. Tracking Balance Adjustment VR (TBC)
6. Focus Balance Adjustment VR (FBC)

Total 6 Adjustment VRs

On SL-SW415
Use for New Servo IC (AN8837SBE1, MN662746RPK1)

- ➔ Non Adjustment
- ➔ Automatic Adjusting Circuit
- ➔ No Adjustment VR

Although all discs are manufactured according to the same specifications, their characteristics are not always precisely the same because they are produced by different manufacturers in various lots, or have different warp etc. SL-SW415 automatically controls the servo circuit to obtain optimum performance according to any disc's characteristics. Therefore, no malfunction occurs because of mis-adjustment.

■ Outline of 10 - Second Sound Keeper Technique Used for Prevention of Sound from Skipping

1. Conventional Shockproofing Technique

Input information read out of the CD at double speed is demodulated, stored in the memory, and while sound-marking signal is supplied at normal speed from the memory to the D/A converter, the residual data is accumulated in the memory.

If reaccess to the break point is accomplished before the memory becomes empty, apparent playback sound is entirely kept free from breaking even when information pauses due to vibration, etc. It was necessary to use the 4M bit memory for securing the accumulation time of about 10 seconds.

2. Compression-shockproofing

[Outline]

Fig. 1 is a block diagram showing the compression-shockproofing mechanism, the difference of which from the conventional mechanism is as follows: Input information read out at double speed undergoes data compression (16 bits → 4 bits) by the encoder in the ADPCM (Adaptive Difference PCM) and stored in the external memory; the stored memory information undergoes data elongation (4 bits → 16 bits) by the decoder in the ADPCM and supplied at normal speed to the D/A converter.

The data compression technique has conducted to reduction of required memory capacity from 4M bits to 1M bit for securing the accumulation time equivalent to the conventional.

All-inclusive Block Diagram

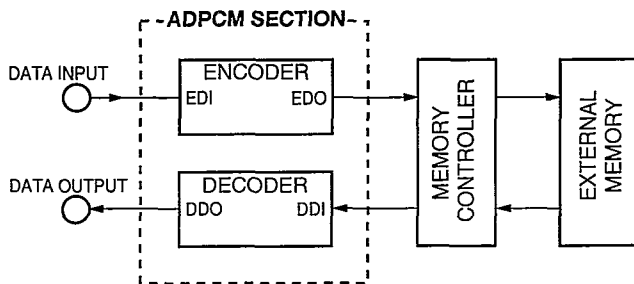

Block Diagram

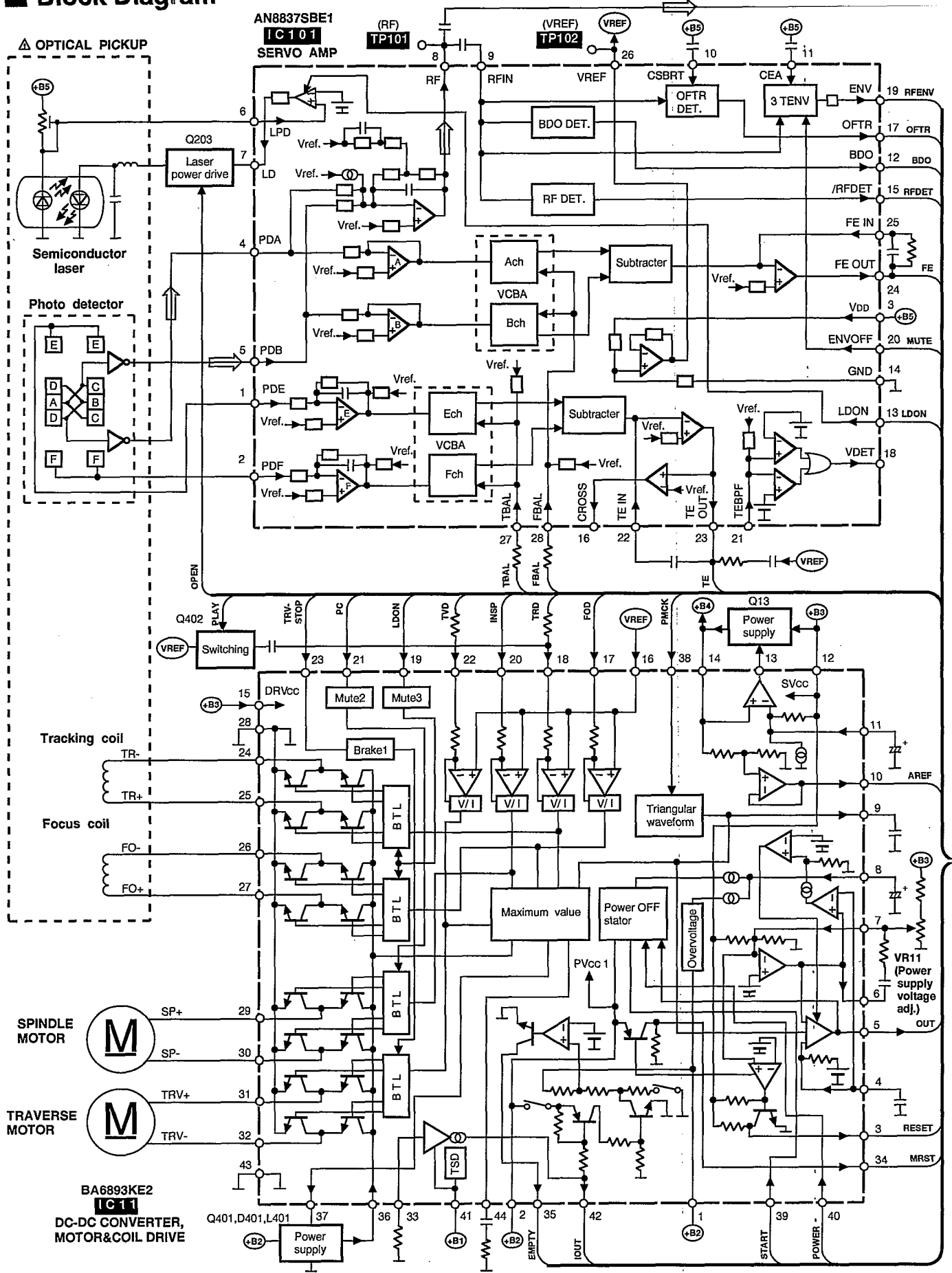

● Signal line ⇨ : Audio signal

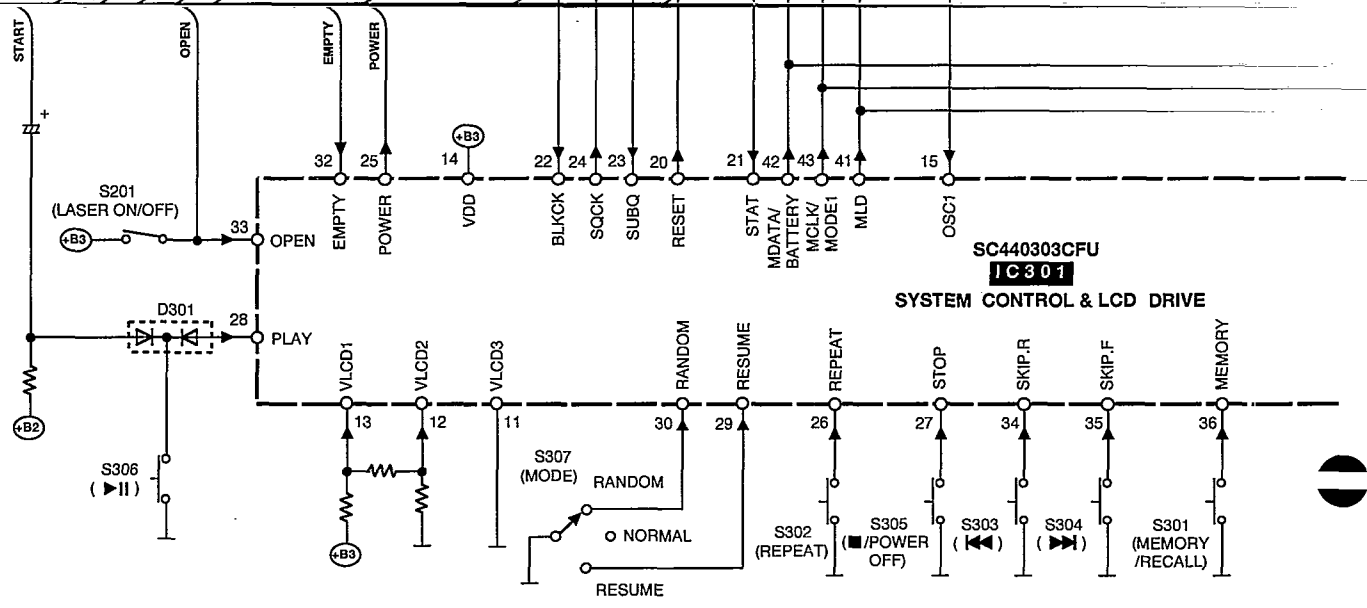
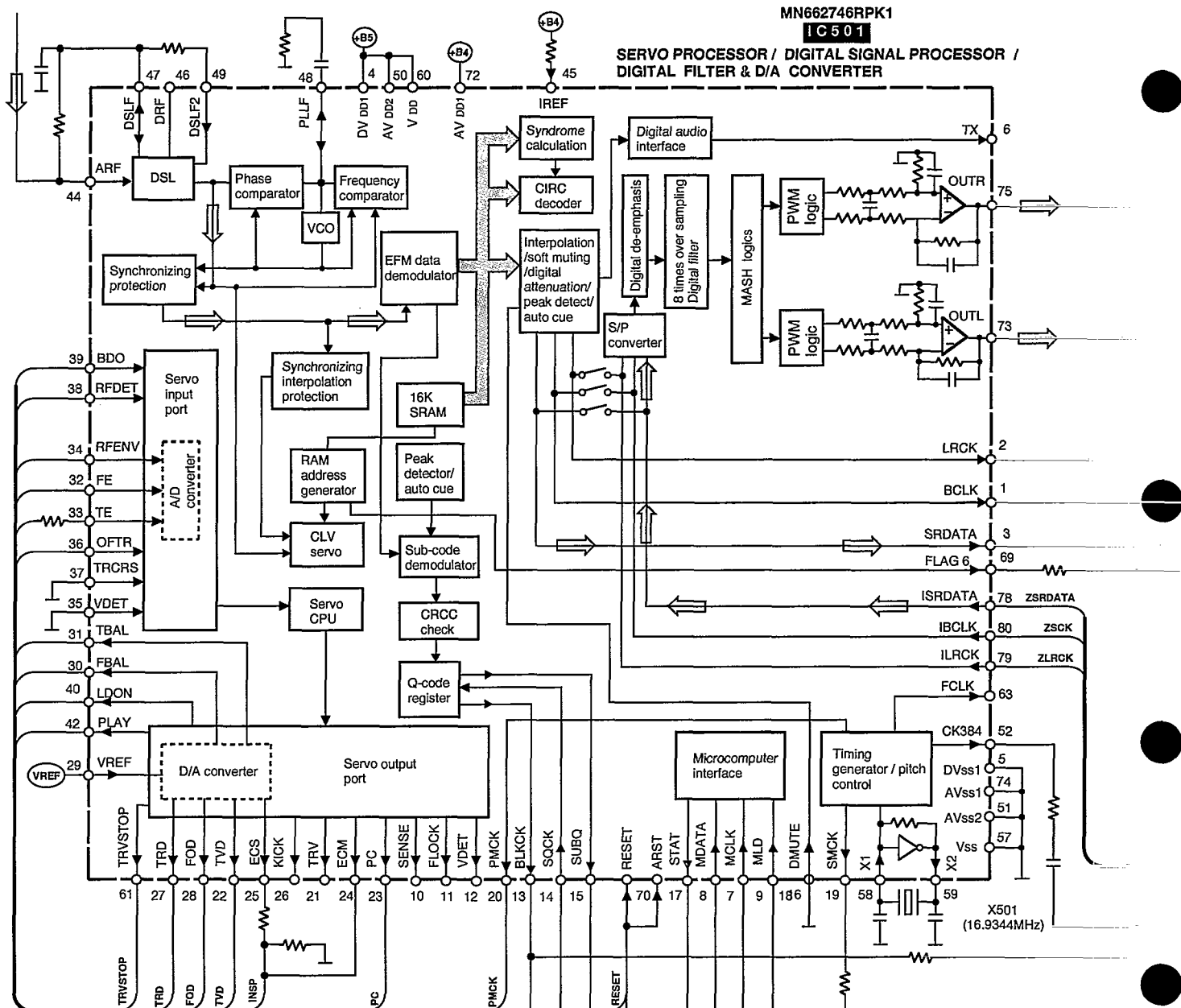

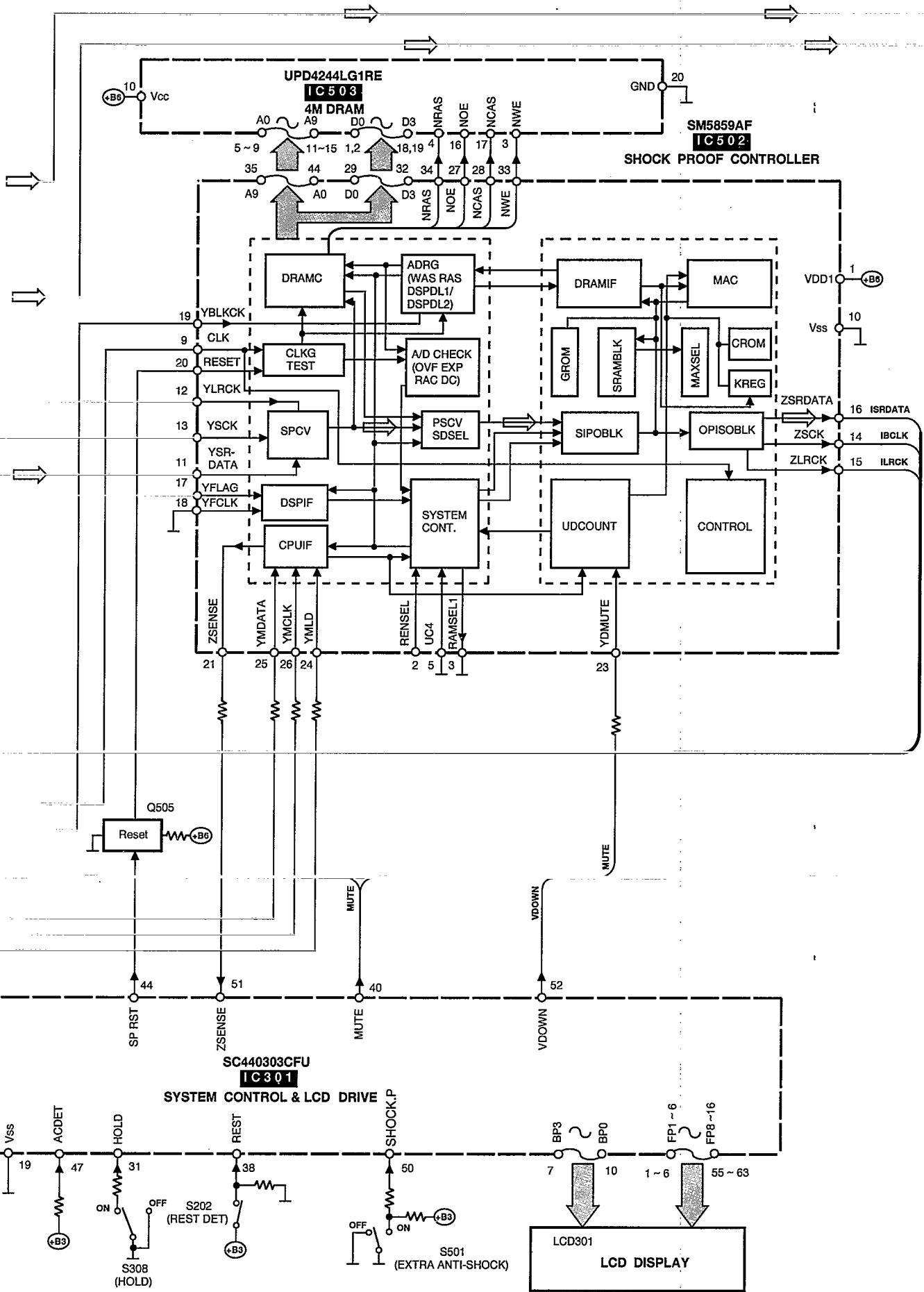

● Signal line ⇨ : Audio signal

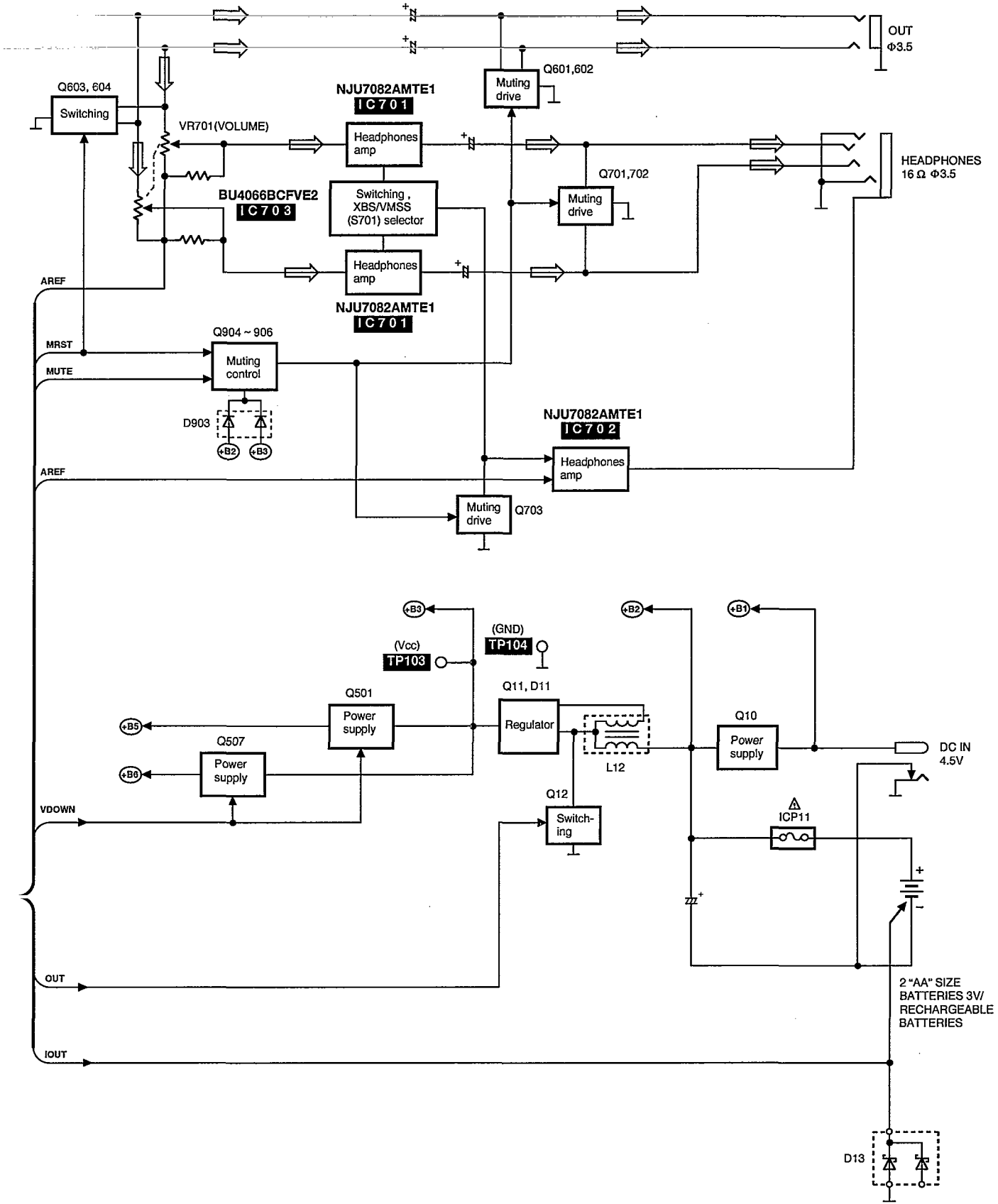

■ Schematic Diagram (See parts list on pages 33~37.)

(This schematic diagram may be modified at any time with the development of new technology.)

Notes:

- **S201** : Laser ON/OFF switch in "OFF" position.
(It turns "ON" with disc holder closed.)
- **S202** : Rest detector in "OFF" position.
(It turns "ON" when optical pickup comes to innermost periphery.)
- **S301** : Memory/recall (MEMORY/RECALL) switch.
- **S302** : Repeat (REPEAT) switch.
- **S303** : Skip/search (▶▶▶ / ▶▶ , ◀◀ / ◀◀) switches.
- **S304** : [S303: GO BACK, S304: ADVANCE]
- **S305** : Stop/power off (■/POWER OFF) switch.
- **S306** : Play/pause (▶ / ||) switch.
- **S307** : Play mode selector (MODE) in "RANDOM" position.
(RANDOM↔NORMAL↔RESUME)
- **S308** : Hold (HOLD) switch in "ON" position.
- **S501** : Extra anti-shock(EXTRA ANTI-SHOCK) switch in "OFF" position.
- **S701** : XBS/VMSS selector (XBS,VMSS) in "OFF" position.
- **VR11** : Power supply voltage adjustment.
- **VR701-1, 2** : Headphones volume (VOLUME) control.
- The voltage value and waveforms are the reference voltage of this measured by DC electronic voltmeter (high impedance) and oscilloscope on the basis of GND terminal (DC IN Jack).
Accordingly, there may arise some errors in the voltage values and waveforms depending upon the internal impedance of the tester or measuring unit.

Measurement conditions:

- * Set the HOLD and EXTRA ANTI-SHOCK switches to ON.
- * The parenthesized is the voltage for test disc (1 kHz, L + R, 0 dB) in play mode, and the other, for no disc in stop mode.
- * AC adaptor is used for power supply.

●  : Positive voltage lines.

●  : Audio signal lines.

Important safety notice:

Components identified by Δ mark have special characteristics important for safety. Furthermore, special parts which have purposes of fire-retardant (resistors), high-quality sound (capacitors), low-noise (resistors), etc. are used. When replacing any of components, be sure to use only manufacturer's specified parts shown in the parts list.

Caution!

IC and LSI are sensitive to static electricity. Secondary trouble can be prevented by taking care during repair.

- Cover the parts boxes made of plastics with aluminum foil.
- Ground the soldering iron.
- Put a conductive mat on the work table.
- Do not touch the pins of IC or LSI with fingers directly.

■ Type Illustration of IC's, Transistors and Diodes

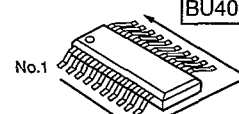
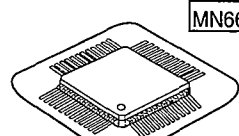
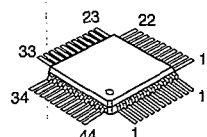
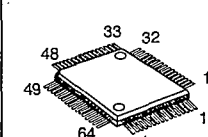
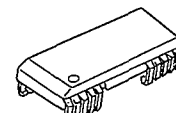
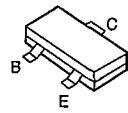
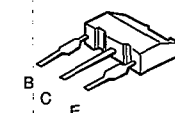
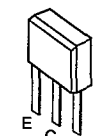
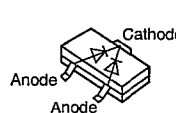
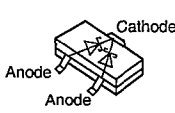
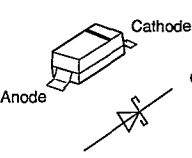
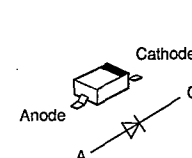
<p>No.1</p>  <table border="1"> <tr><td>NJU7082AMTE1</td><td>8PIN</td></tr> <tr><td>AN8837SBE1</td><td>28PIN</td></tr> <tr><td>BU4066BCFVE2</td><td>14PIN</td></tr> </table>	NJU7082AMTE1	8PIN	AN8837SBE1	28PIN	BU4066BCFVE2	14PIN	<p>No.1</p>  <table border="1"> <tr><td>SM5859AF</td><td>44PIN</td></tr> <tr><td>MN662746RPK1</td><td>80PIN</td></tr> </table>	SM5859AF	44PIN	MN662746RPK1	80PIN	<p>BA6893KE2</p> 	<p>SC440303CFU</p> 
NJU7082AMTE1	8PIN												
AN8837SBE1	28PIN												
BU4066BCFVE2	14PIN												
SM5859AF	44PIN												
MN662746RPK1	80PIN												
<p>UPD4244LG1RE</p> 	<p>2SB970RSTX 2SD1328RSTTX DTA114YUA106 MSB1218ART1 MSB709RST1</p> <p>UN5215TX UN5210TX UN511NTX</p> 	<p>2SD2074HWRST</p> 	<p>2SD1302STTA 2SD1450STTA</p> 										
<p>M1MA141WKT1</p> 	<p>RB411DT146</p> 	<p>D1FS4</p> 	<p>MA110TX</p> 										

Note: ● →: Audio signal lines.

(P.C.Board: on pages 26,27)

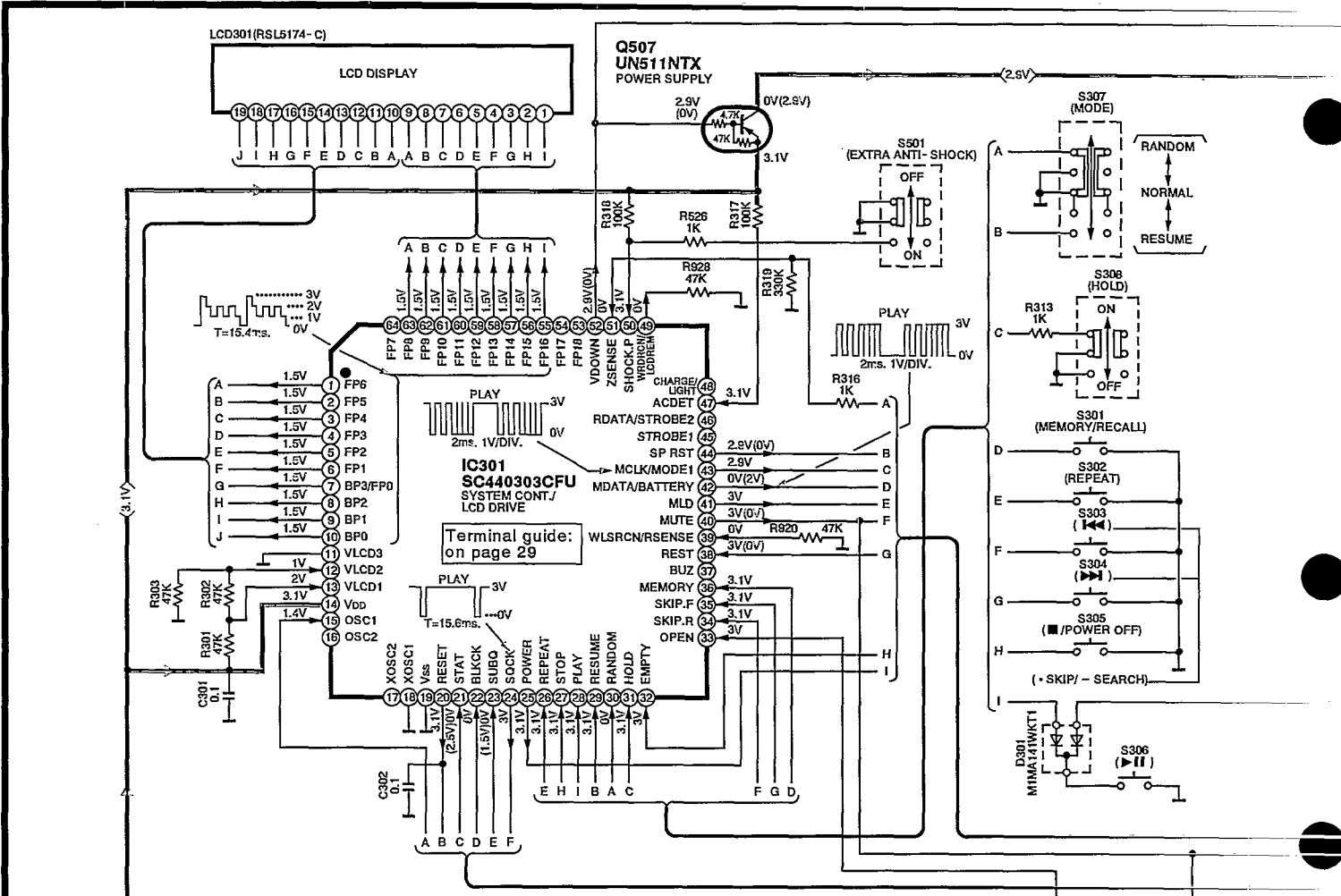

△ OPTICAL PICKUP

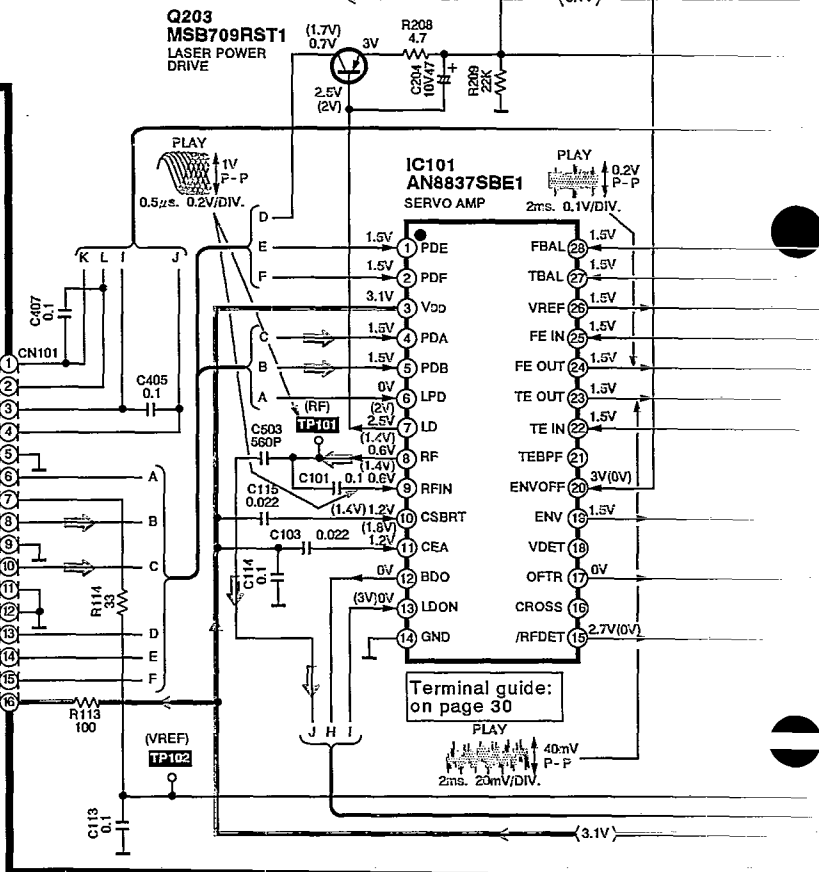
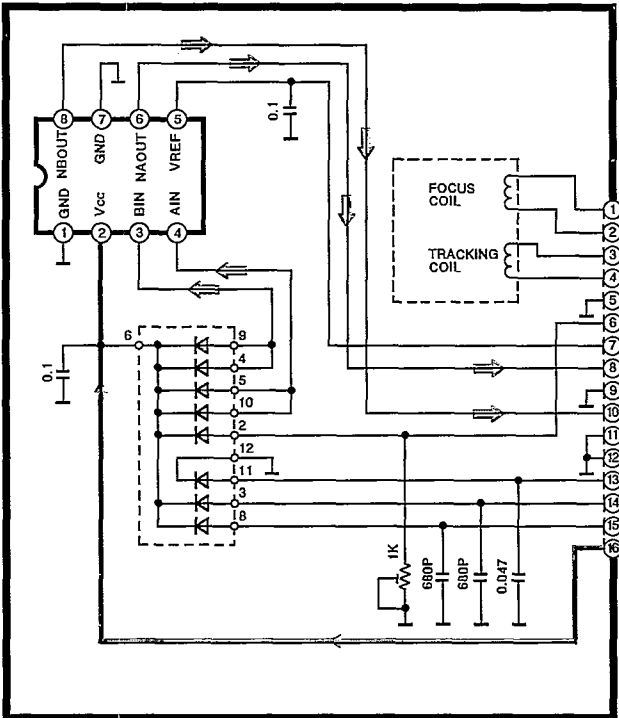

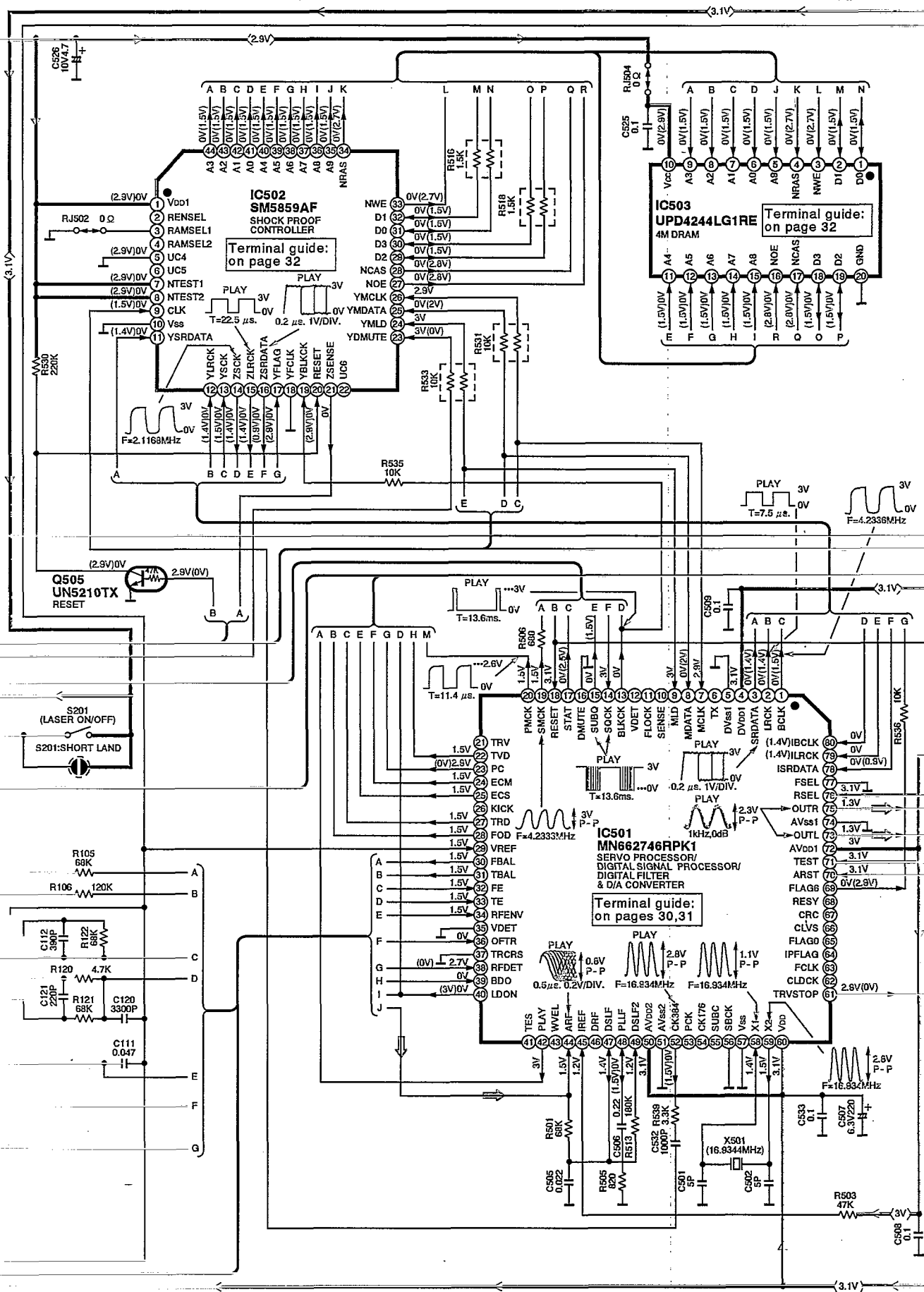

Note: ● →: Audio signal lines.

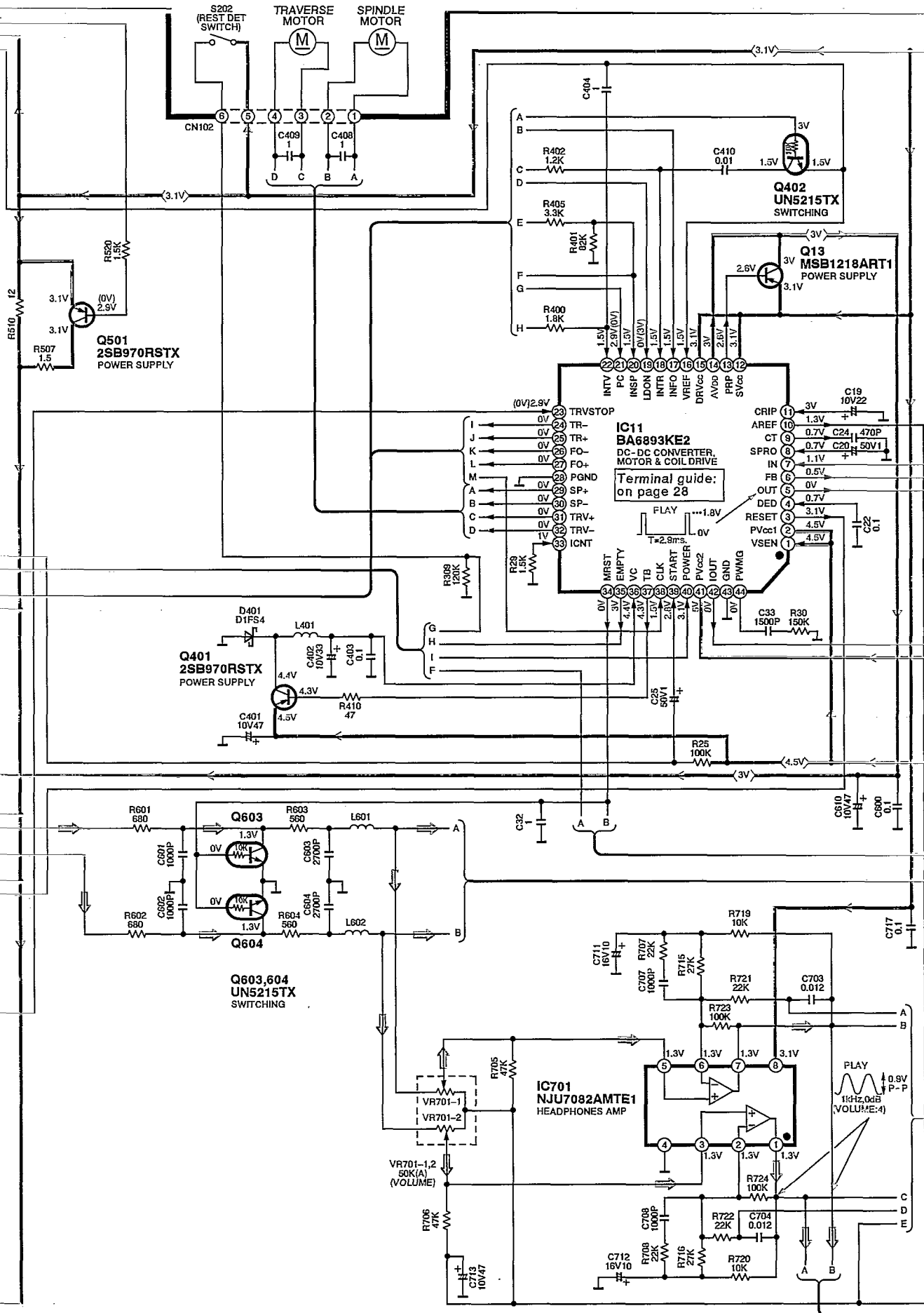

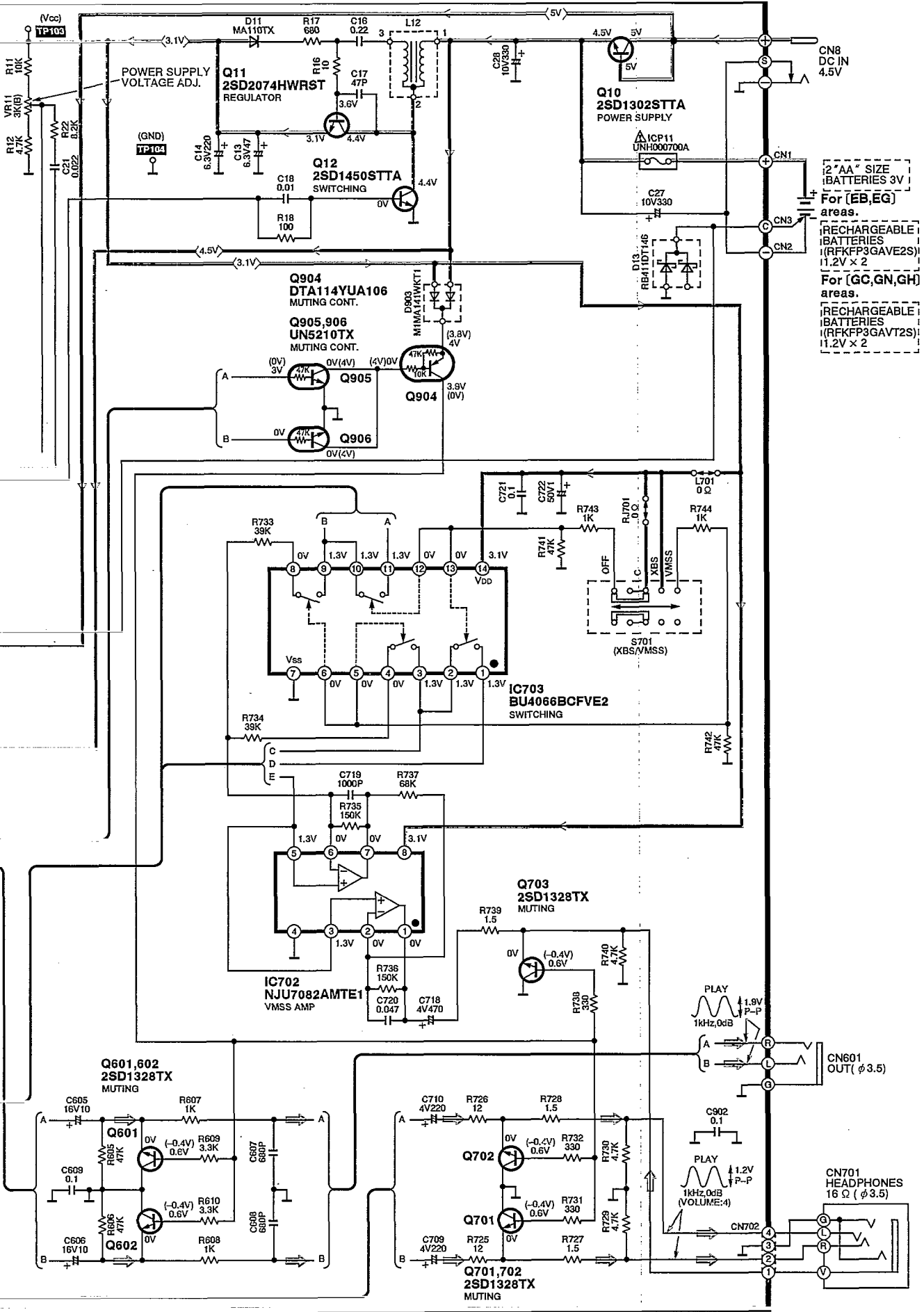

Printed Circuit Board and Wiring Connection Diagram

Notes:

- In this printed circuit board diagram, the parts and foil patterns on the board facing toward you are printed in black. The opposite side is printed in blue.
- The "●" and "●" marks denote the connection points of double-faced foil patterns (through holes) on both sides of the printed circuit board.

- This printed circuit board diagram may be modified at any time with the development of new technology.

2 "AA" SIZE BATTERIES 3V
 For [EB,EG] areas.
 RECHARGEABLE BATTERIES (RFKFP3GAVE2S) 1.2V x 2
 For [GC,GN,GH] areas.
 RECHARGEABLE BATTERIES (RFKFP3GAVT2S) 1.2V x 2

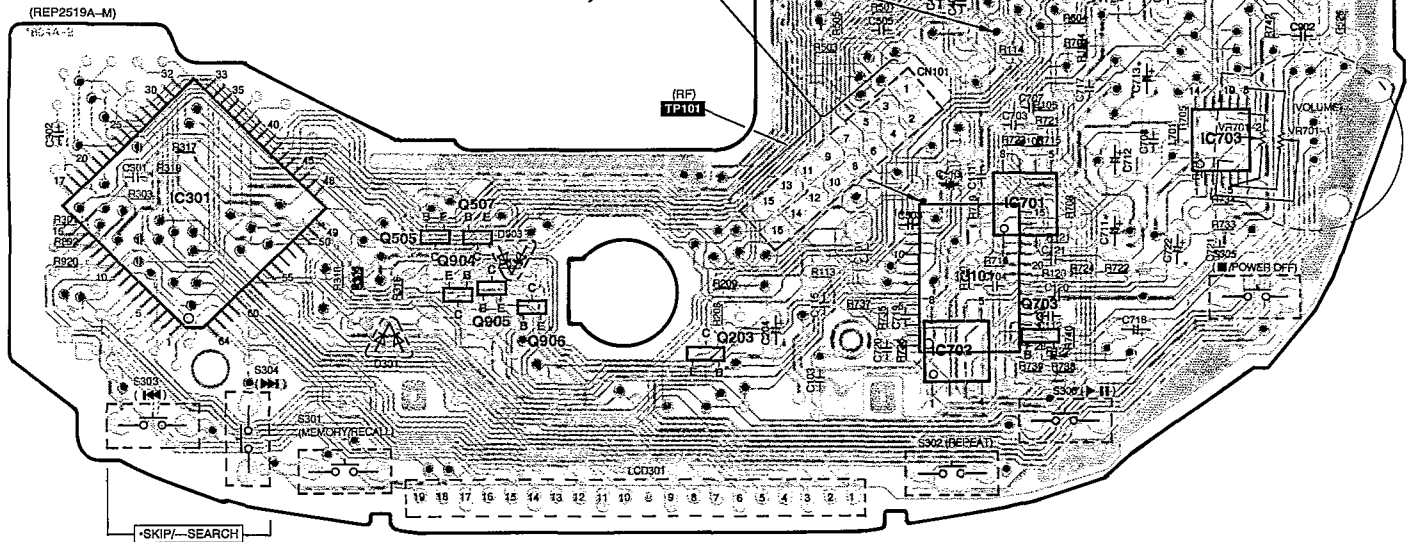
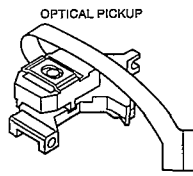
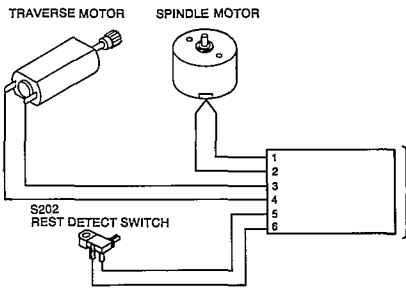
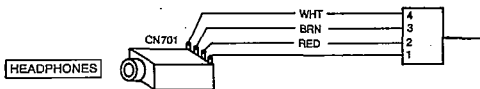

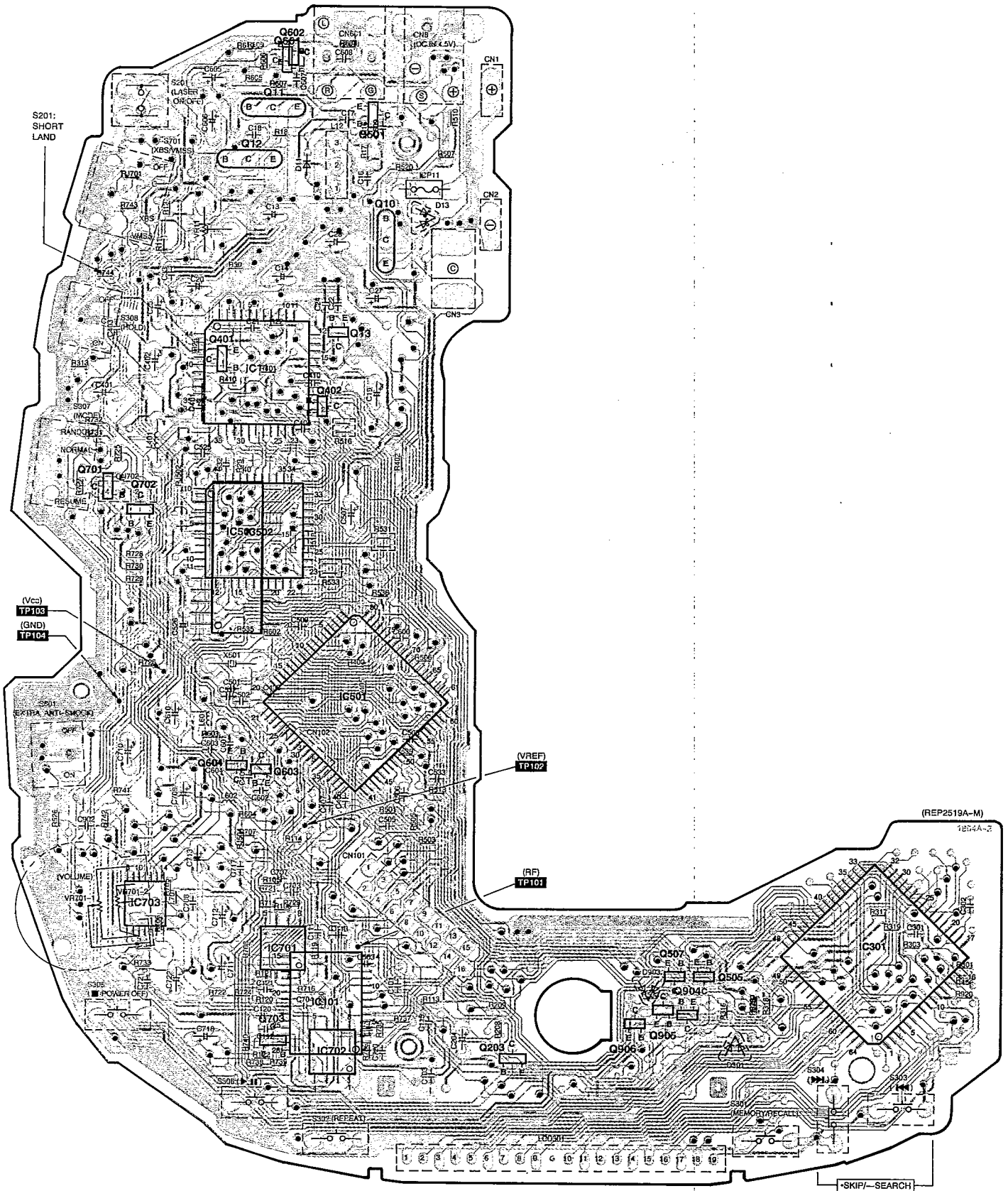

Terminal Function of IC's

● IC11 (BA6893KE2): DC-DC converter control & motor drive

Pin No.	Mark	I/O Division	Function
1	VSEN	I	Battery voltage monitor terminal
2	PVcc	I	Battery power supply input terminal
3	RESET	O	Reset signal output terminal
4	DED	I	Dead time setting terminal
5	OUT	O	Boost transistor drive output terminal
6	FB	O	Error amp output terminal
7	IN	I	Error amp input terminal
8	SPRO	I	Short protect setting input terminal
9	CT	O	Triangle wave oscillator output terminal
10	AREF	O	Audio reference output terminal
11	CRIP	I	Ripple filter smoothing terminal
12	SVcc	I	Power supply input terminal for control circuit
13	PRP	O	Transistor drive output terminal for ripple filter
14	AVDD	O	Power supply output terminal for ripple filter
15	DRVcc	I	Pre-driver power supply input terminal
16	VRFF	I	Reference voltage input terminal
17	INFO	I	Focus coil drive input terminal
18	INTR	I	Tracking coil drive input terminal
19	LDON	I	Laser ON/OFF drive input terminal
20	INSP	I	Spindle motor drive input terminal
21	PC	I	Spindle motor drive ON/OFF input terminal
22	INTV	I	Traverse motor drive input terminal

Pin No.	Mark	I/O Division	Function
23	TRVSTOP	I	Traverse motor drive ON/OFF input terminal
24	TR-	O	Tracking coil drive output terminal
25	TR+		
26	FO-	O	Focus coil drive output terminal
27	FO+		
28	PGND	—	Power section GND terminal
29	SP+	O	Spindle motor drive output terminal
30	SP-		
31	TRV+	O	Traverse motor drive output terminal
32	TRV-		
33	ICNT	I	Rechargeable current setting terminal
34	MRST	O	Muting reset output terminal
35	EMPTY	O	Empty detect output terminal
36	VC	I	Power supply input terminal
37	TB	O	PWM transistor drive output terminal
38	CLK	I	External clock synch. input terminal
39	START	I	Boost DC/DC converter starting input terminal
40	POWER	I	Boost DC/DC converter OFF input terminal
41	PVcc2	I	Rechargeable circuit power supply input terminal
42	IOUT	O	Empty detect level select output terminal
43	GND	—	Pre-section GND terminal
44	PWMG	I	PWM phase compensating input terminal

● IC301 (SC440303CFU): System control & LCD drive

Pin No.	Mark	I/O Division	Function
1 } 6	FP6 } FP1	O	LCD segment signal output terminal
7	BP3/FP0		
8 } 10	BP2 } BP0		
11 } 13	VLCD3 } VLCD1	I	Voltage control input terminal
14	V _{DD}	I	Power supply terminal
15	OSC1	I	Main system clock input terminal
16	OSC2	—	Not used, open
17	XOSC2	—	Not used, open
18	XOSC1	—	Not used, connected to GND
19	V _{SS}	—	GND terminal
20	RESET	O	Reset signal output terminal
21	STAT	I	Status signal input (CRC, CUE, CLVS, TT STOP, FCLV, SQOK)
22	BLKCK	I	Sub-code block clock (F=75Hz with normal play)
23	SUBQ	I	Sub-code Q data input terminal
24	SQCK	O	Sub-code Q register clock signal output terminal
25	POWER	O	Power On/Off signal output terminal
26	REPEAT	I	Key switch(REPEAT) input terminal
27	STOP	I	Key switch(STOP) input terminal
28	PLAY	I	Key switch(PLAY/PAUSE) input terminal
29	RESUME	I	Key switch(RESUME) input terminal
30	RANDOM	I	Key switch(RANDOM) input terminal
31	HOLD	I	Key switch(HOLD) input terminal
32	EMPTY	I	Empty detect input terminal

Pin No.	Mark	I/O Division	Function
33	OPEN	I	Disc holder open det. terminal ("L" : open)
34	SKIP. R	I	Key switch(SKIP/SEARCH. R) input terminal
35	SKIP. F	I	Key switch(SKIP/SEARCH. F) input terminal
36	MEMORY	I	Key switch(MEMORY) input terminal*
37	BUZ	O	Beep control signal output terminal (Not used, open)
38	REST	I	Rest det. input terminal
39	WLSRCN/ RSENSE	I	Remote control signal input terminal.
40	MUTE	O	Muting signal output terminal ("H" : mute)
41	MLD	O	Command load signal output terminal ("L" : load)
42	MDATA/ BATTERY	O	Command data signal output terminal
43	MCLK/ MODE1	O	Command clock signal output terminal
44	SP RST	O	Reset signal output terminal for shock proof controller IC
45	STROBE1	—	Remote control clock signal output terminal (Not used, open)
46	RDATA/ STROBE2	O	Remote control data signal output terminal (Not used, open)
47	ACDET	I	Power det. input terminal
48	CHARGE/ LIGHT	—	Not used, open
49	WRDRCN/ LCDREM	O	Remote control signal output terminal
50	SHOCK. P	I	Key switch(X-DSSP) input terminal
51	ZSENSE	I	Sense signal input terminal
52	VDOWN	O	Power supply control output terminal
53 . 54	FP18 . FP17	—	Not used, open
55 } 63	FP16 } FP8	O	LCD segment signal output terminal
64	FP7	—	Not used, open

● IC101 (AN8837SBE1): Servo amp.

Pin No.	Mark	I/O Division	Function
1	PDE	I	Tracking signal input terminal (1)
2	PDF	I	Tracking signal input terminal (2)
3	V _{DD}	I	Power supply terminal
4	PDA	I	Focus signal input terminal (1)
5	PDB	I	Focus signal input terminal (2)
6	LPD	I	APC amp input terminal
7	LD	O	APC amp output terminal
8	RF	O	RF summing output terminal
9	RF IN	I	RF signal input terminal
10	CSBRT	I	Capacitor connection terminal for OFTR
11	CEA	I	Capacitor connection terminal for H.P.F. amp
12	BDO	O	Dropout signal output terminal ("H" : Dropout)
13	LDON	I	APC control input terminal
14	GND	—	GND terminal

Pin No.	Mark	I/O Division	Function
15	/RFDET	O	RF det. signal output terminal ("L" : Det.)
16	CROSS	—	Track cross signal output terminal (Not used, open)
17	OFTR	O	Off track signal output terminal ("H" : Off track)
18	VDET	—	Vibration det. signal output terminal ("H" : Det.) (Not used, open)
19	ENV	O	RF envelope signal output terminal
20	ENV OFF	I	ENV control input terminal
21	TEBPF	—	Not used, open
22	TE IN	I	Tracking error amp input terminal
23	TE OUT	O	Tracking error amp output terminal
24	FE OUT	O	Focus error amp output terminal
25	FE IN	I	Focus error amp input terminal
26	VREF	O	Reference voltage output terminal
27	TBAL	I	Tracking balance signal input terminal
28	FBAL	I	Focus balance signal input terminal

● IC501 (MN662746RPK1) : Servo processor / digital signal processor / digital filter / D/A converter

Pin No.	Mark	I/O Division	Function
1	BCLK	O	Serial bit clock output
2	LRCK	O	L/R discriminating signal output
3	SRDATA	O	Serial data signal output
4	DV _{DD1}	I	Power supply (digital circuit) terminal
5	DV _{SS1}	—	GND (digital circuit) terminal
6	TX	—	Digital audio interface signal output (Not used, open)
7	MCLK	I	Command clock signal
8	MDATA	I	Command data signal
9	MLD	I	Command load signal ("L" : LOAD)
10	SENSE	O	Sense signal (OFT, FESL, NACEND, NAJEND, POSAD, SFG) (Not used, open)
11	FLOCK	O	Optical servo condition (focus) ("L" : lead-in) (Not used, open)
12	VDET	—	Not used, open

Pin No.	Mark	I/O Division	Function
13	BLKCK	O	Sub-code block clock (f=75Hz)
14	SQCK	I	Sub-code Q register clock
15	SUBQ	O	Sub-code Q code
16	DMUTE	I	Muting input ("H" : MUTE) (Not used, connected to GND)
17	STAT	O	Status signal (CRC, CUE, CLVS, TTSTOP, FCLV, SQCK)
18	RESET	I	Reset signal ("L" : reset)
19	SMCK	O	System clock (f=4.2336MHz)
20	PMCK	O	Frequency division clock signal (f=1/1.92×ck=88.2kHz)
21	TRV	O	Traverse servo control (Not used, open)
22	TVD	O	Traverse drive signal
23	PC	O	Spindle motor drive signal ("L" : ON)
24	ECM	O	Spindle motor drive signal (Forced mode)
25	ECS	O	Spindle motor drive signal (Servo error signal)

Pin No.	Mark	I/O Division	Function
26	KICK	—	Kick pulse output (Not used, open)
27	TRD	O	Tracking drive signal output
28	FOD	O	Focus drive signal output
29	VREF	I	D/A drive output (TVD, ECS, TRD, FOD, FBAL, TBAL) normal voltage input terminal
30	FBAL	O	Focus balance adj. output
31	TBAL	O	Tracking balance adj. output
32	FE	I	Focus error signal (analog input)
33	TE	I	Tracking error signal (analog input)
34	RFENV	I	RF envelope signal
35	VDET	I	Oscillation det. signal input ("H" : det) (Not used, connected to GND)
36	OFTR	I	Off track signal input ("H" : Off track)
37	TRCRS	I	Track cross signal input
38	RFDET	I	RF detection signal ("L" : detection)
39	BDO	I	Dropout detection signal ("H" : dropout)
40	LDON	O	Laser power control ("H" : ON)
41	TES	O	Tracking error shunt output ("H" : dropout) (Not used, open)
42	PLAY	O	Play signal ("H" : play) (Not used, open)
43	WVEL	O	Double velocity status signal ("H" : double) (Not used, open)
44	ARF	I	RF signal input
45	IREF	I	Reference current input
46	DRF	—	DSL bias terminal (Not used, open)
47	DSLIF	I/O	DSL loop filter terminal
48	PLLIF	I/O	PLL loop filter terminal
49	DSLIF2	I	VCO loop filter terminal
50	AVDD2	I	Power supply (analog circuit) terminal (2)
51	AVSS2	—	GND (analog circuit) terminal
52	CK384	O	384fs (16.9344MHz) output
53	PCK	—	PLL extract clock (f=4.3218MHz) (Not used, open)
54	CK176	—	Not used, open

Pin No.	Mark	I/O Division	Function
55	SUBC	—	Sub-code serial output data (Not used, open)
56	SBCK	—	Sub-code serial input clock (Not used, connected to GND)
57	VSS	—	GND terminal
58	X1	I	Crystal oscillator input terminal (f=16.9344MHz)
59	X2	O	Crystal oscillator output terminal (f=16.9344MHz)
60	VDD	I	Power supply terminal
61	TRVSTOP	O	Traverse motor stop control terminal
62	CLDCK	—	Sub-code frame clock signal (f CLDCK=7.35kHz: Normal) (Not used, open)
63	FCLK	—	Crystal frame clock signal [f FCLK=7.35kHz: 2 speed(14.7kHz)] (Not used, open)
64	IPFLAG	—	Interpolation flag terminal (Not used, open)
65	FLAG0	—	Flag terminal (Not used, open)
66	CLVS	—	Turntable servo phase synchro signal ("H": CLV, "L": Rough servo) (Not used, open)
67	CRC	—	Sub-code CRC check terminal ("H": OK, "L": NG) (Not used, open)
68	RESY	—	Not used, open
69	FLAG6	O	Flag terminal
70	ARST	I	Reset signal input terminal
71	TEST	I	Test terminal (Normal : "H")
72	AVDD1	I	Power supply (analog circuit) terminal (1)
73	OUTL	O	Lch audio signal
74	AVSS1	—	GND (analog circuit) terminal (1)
75	OUTR	O	Rch audio signal
76	RSEL	I	Polarity direction control terminal of RF signal (Not used, connected to power supply)
77	FSEL	—	Frequency control terminal of crystal oscillator ("L": 16.9344MHz)
78	ISRDATA	I	Serial data signal input
79	ILRCK	I	L/R discriminating signal input
80	IBCLK	I	Serial bit clock input

● IC502 (SM5859AF) : Shock proof controller

Pin No.	Mark	I/O Division	Function
1	VDD1	I	Power supply terminal
2	RENSEL	—	Not used, connected to GND
3	RAMSEL1	—	Not used, connected to GND
4	RAMSEL2	—	Not used, open
5	UC4	I	Not used, connected to GND
6	UC5	O	Not used, open
7	NTEST1	I	Test terminal
8	NTEST2		
9	CLK	I	Clock signal input terminal (f= 16.9344MHz)
10	Vss	—	GND terminal
11	YSRDATA	I	Serial data input terminal
12	YLCK	I	L/R clock input terminal
13	YSCK	I	Serial bit clock input terminal
14	ZSCK	O	Serial bit clock output terminal
15	ZLRCK	O	L/R clock output terminal
16	ZSRDATA	O	Serial data output terminal
17	YFLAG	I	RAM over-flow flag terminal

Pin No.	Mark	I/O Division	Function
18	YFCLK	I	Crystal frame clock input (Not used, open)
19	YBLKCK	I	Sub-cord block clock input terminal
20	RESET	I	Reset input terminal
21	ZSENSE	O	Microcomputer states output terminal
22	UC6	—	Not used, open
23	YDMUTE	I	Mute input terminal
24	YMLD	I	Microcomputer latch clock input terminal
25	YMDATA	I	Microcomputer serial data input terminal
26	YMCLK	I	Microcomputer shift clock input terminal
27	NOE	O	D-RAM output enable terminal
28	NCAS	O	D-RAM column address strobe terminal
29 30	D2 D3	I/O	D-RAM data input/output terminal
31 32	D0 D1		
33	NWE		
34	NRAS	O	D-RAM low address strobe terminal
35 36 37 38 39 40	A9 ∩ ∩ ∩ ∩ A4	O	D-RAM address output terminal
41 42 43 44	A0 ∩ ∩ A3		

● IC503 (UPD4244LG1RE) : 4M DRAM

Pin No.	Mark	I/O Division	Function
1	D0	I/O	Data input/output terminal
2	D1	I/O	Data input/output terminal
3	NWE	I	Write enable terminal
4	NRAS	I	Low address strobe terminal
5	A9	I	Address input terminal
6	A0	I	Address input terminal
7 8 9	A1 ∩ A3	I	Address input terminal

Pin No.	Mark	I/O Division	Function		
10	Vcc	I	Power supply terminal		
11 12 13 14 15	A4 ∩ ∩ ∩ A8	I	Address input terminal		
16	NOE			I	Output enable terminal
17	NCAS			I	Column address strobe terminal
18	D3			I/O	Data input/ output terminal
19	D2			I/O	Data input/ output terminal
20	GND	—	GND terminal		

Replacement Parts List (Electrical)

Notes: * Important safety notice:

 Components identified by Δ mark have special characteristics important for safety.

Furthermore, special parts which have purposes of fire-retardant (resistors), high-quality sound (capacitors), low-noise (resistors), etc. are used.

When replacing any of components, be sure to use only manufacturer's specified parts shown in the parts list.

* The parenthesized indications in the Remarks columns specify the areas. (Refer to the cover page for area.)

Parts without these indications can be used for all areas.

* Warning: This product uses a laser diode. Refer to caution statements on page 2.

* ACHTUNG: Die Lasereinheit nicht zerlegen.

Die Lasereinheit darf nur gegen eine vom Hersteller spezifizierte Einheit ausgetauscht werden.

* [M] indicates in Remarks column parts that are supplied by MESA.

Ref. No.	Part No.	Part Name & Description	Remarks	Ref. No.	Part No.	Part Name & Description	Remarks
		INTEGRATED CIRCUIT(S)				VARIABLE RESISTOR(S)	
IC11	BA6893KE2	IC	[M]	VR11	EVNDXAA00B33	V. R	[M]
IC101	AN8837SBE1	IC	[M]	VR701	EVUTOVA05A54	V. R	[M]
IC301	SC440303CFU	IC	[M]			COIL(S)	
IC501	MN662746RPK1	IC	[M]	L12	RLZ0028T-0	COIL	[M]
IC502	SM5859AF	IC	[M]	L401	RLQB330KT-M	COIL	[M]
IC503	UPD4244LG1RE	IC	[M]	L601, 602	RLBV121AV-I	COIL	[M]
IC701, 702	NJU7082AMTE1	IC	[M]	L701	ERJ3GEYOR00V	CHIP JUMPER	[M]
IC703	BU4066BCFVE2	IC	[M]			OSCILLATOR(S)	
		TRANSISTOR(S)		X501	RSXZ16M9M01T	OSCILLATOR	[M]
Q10	2SD1302STTA	TRANSISTOR	[M]			LCD(S)	
Q11	2SD2074HWRST	TRANSISTOR	[M]	LCD301	RSL5174-C	LCD	[M]
Q12	2SD1450STTA	TRANSISTOR	[M]			SWITCH(ES)	
Q13	MSB1218ART1	TRANSISTOR	[M]	S201	ESE11SV6	SW	[M]
Q203	MSB709RST1	TRANSISTOR	[M]	S202	ESE11HS4	SW	[M]
Q401	2SB970RSTX	TRANSISTOR	[M]	S301-306	EVQ21405R	SW	[M]
Q402	UN5215TX	TRANSISTOR	[M]	S307	RSS3A010-A	SW	[M]
Q501	2SB970RSTX	TRANSISTOR	[M]	S308	RSS2A018-A	SW	[M]
Q505	UN5210TX	TRANSISTOR	[M]	S501	RSS2A018-A	SW	[M]
Q507	UN511NTX	TRANSISTOR	[M]	S701	RSS3A010-A	SW	[M]
Q601, 602	2SD1328QRSTX	TRANSISTOR	[M]			CONNECTOR(S) AND JACK(S)	
Q603, 604	UN5215TX	TRANSISTOR	[M]	CN1	RJC93015-1	BATTERY TERMINAL(+)	[M]
Q701-703	2SD1328QRSTX	TRANSISTOR	[M]	CN2	RJC93015-1	BATTERY TERMINAL(-)	[M]
Q904	DTA114YUA106	TRANSISTOR	[M]	CN3	RJR0166	RECHARGEABLE BATT. TERMINAL	[M]
Q905, 906	UN5210TX	TRANSISTOR	[M]	CN8	RJJ43K09-C	DC IN JACK	[M]
		DIODE(S)		CN101	RJS2A4716M1	CONNECTOR(16P)	[M]
D11	MA110TX	DIODE	[M]	CN102	RJS2A5106T1	CONNECTOR(6P)	[M]
D13	RB411DT146	DIODE	[M]	CN601	RJJD3S5ZB-C	OUT JACK	[M]
D301	MLMA141WKT1	DIODE	[M]	CN702	RJT068W04ST	CONNECTOR(4P)	[M]
D401	D1FS4	DIODE	[M]				
D903	MLMA141WKT1	DIODE	[M]				
		IC PROTECTOR(S)					
ICP11	UNH000700A	IC	[M] Δ				

Cabinet Parts Location

※ Please ordering assembly parts (RYF0409D-S) when changing **A** parts.

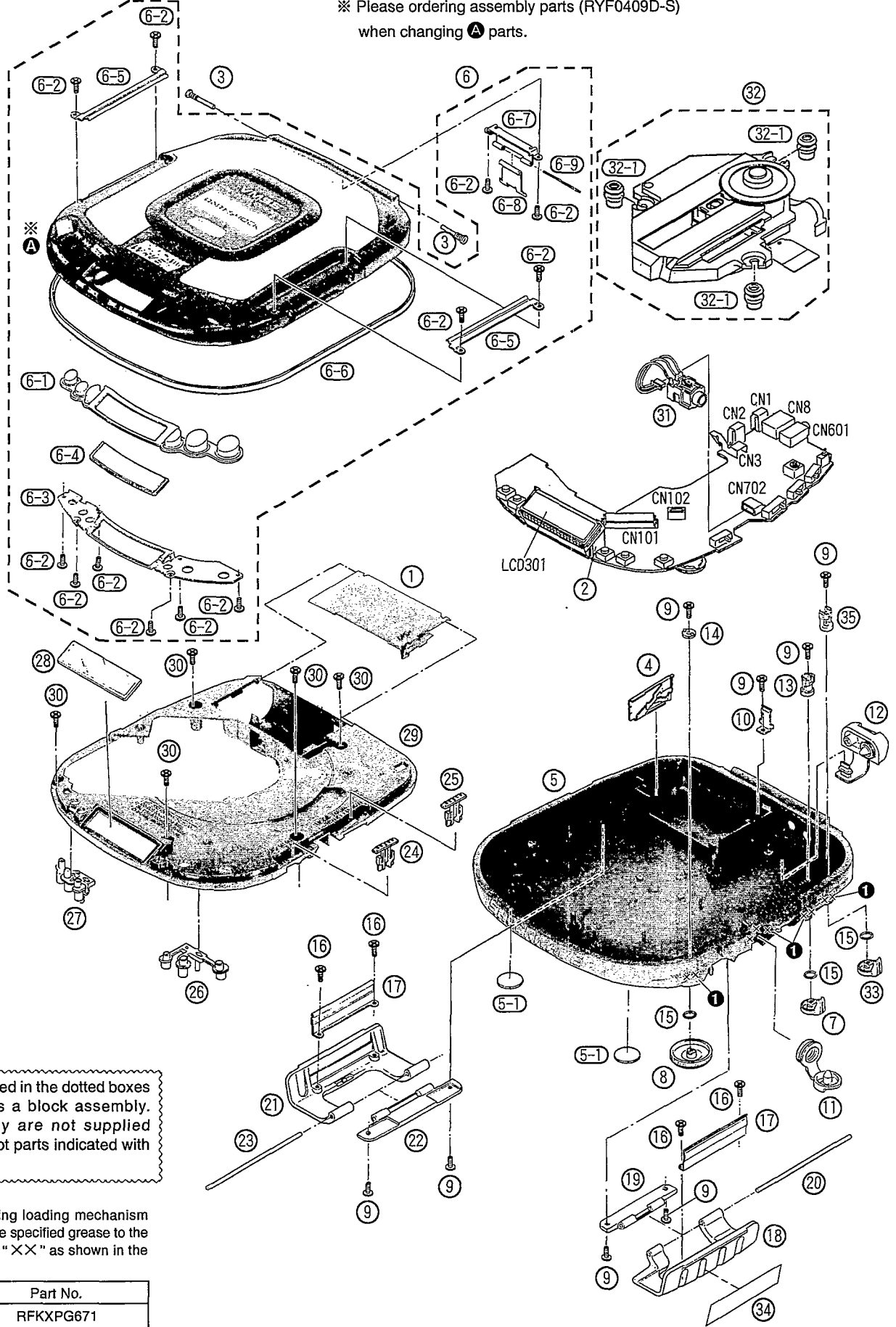

The parts enclosed in the dotted boxes are supplied as a block assembly. Therefore, they are not supplied separately except parts indicated with Ref. No.

Note: When changing loading mechanism parts, apply the specified grease to the areas marked "X" as shown in the drawing.

Ref. No.	Part No.
1	RFKXPG671

Replacement Parts List(Cabinet, Accessories, Packing and Grease or Jig/Tool)

Notes: * Important safety notice:

 Components identified by Δ mark have special characteristics important for safety.

Furthermore, special parts which have purposes of fire-retardant (resistors), high-quality sound (capacitors), low-noise (resistors), etc. are used.

When replacing any of components, be sure to use only manufacturer's specified parts shown in the parts list.

* Warning: This product uses a laser diode. Refer to caution statements on page 2.

* ACHTUNG: Die Lasereinheit nicht zerlegen.

Die Lasereinheit darf nur gegen eine vom Hersteller spezifizierte Einheit ausgetauscht werden.

* [M] indicates in Remarks column parts that are supplied by MESA.

Ref.No.	Part No.	Part Name & Description	Remarks	Ref.No.	Part No.	Part Name & Description	Remarks
		CABINET AND CHASSIS		31	REX0871	H.P. JACK ASS'Y (CN701)	[M]
				32	RAE0142Z	TRAVERSE DECK	[M] Δ
				32-1	RMG0449-H	FLOATING RUBBER	[M]
1	RKK0096-K	BATTERY COVER	[M]	33	RGV0173-D	XBS/VMSS SELECTOR KNOB	[M]
2	RJF0029	LCD HOLDER	[M]	34	RQLA0393	PLUG CAUTION LABEL	[M]
3	RHD20039-K	SCREW	[M]	35	RML0491	OPERATION LEVER(A)	[M]
4	RJC93020	COMMON BATTERY TERMINAL	[M]			PACKING MATERIAL	
5	RFKJLSW415EB	BOTTOM CABINET ASS'Y	[M] (EB)	P1	RPK0915	PACKING CASE	[M] (EB, EG, GC, GN)
5	RFKJLSW415EG	BOTTOM CABINET ASS'Y	[M] (EG)	P1	RPK0916	PACKING CASE	[M] (GH)
5	RFKJLSW415GC	BOTTOM CABINET ASS'Y	[M] (GC)	P2	RPQ0654	PAD	[M] (EB, GH)
5	RFKJLSW415GN	BOTTOM CABINET ASS'Y	[M] (GN)	P2	RPQ0657	PAD	[M] (EG, GN)
5	RFKJLSW415GH	BOTTOM CABINET ASS'Y	[M] (GH)	P3	RPQ0820-1	SPACER	[M]
5-1	RKA0063-K	FOOT	[M]	P4	RPQ0821	SPACER	[M]
6	RYF0409D-S	CD COVER ASS'Y	[M]	P5	RPF0046	PROTECTION BAG (F. B.)	[M]
6-1	RGU1414-D	OPERATION BUTTON	[M]	P6	RPF0111	PROTECTION BAG (UNIT)	[M]
6-2	RHE5119YA	SCREW	[M]			ACCESSORIES	
6-3	RKU0071-K	BUTTON COVER	[M]	A1	RQT3976-B	INSTRUCTION MANUAL	[M] (EB, GN) <IA>
6-4	RKW0456-Q	LCD PANEL (A)	[M]	A1	RQT3977-E	INSTRUCTION MANUAL	[M] (EG, GC) <IB>
6-5	RMA0961	BUCKLE ORNAMENT(B)	[M]	A1	RQT3978-R	INSTRUCTION MANUAL	[M] (EG) <IC>
6-6	RMG0424-D	CABINET WATER PROOF RING	[M]	A1	RQT3979-D	INSTRUCTION MANUAL	[M] (EG) <ID>
6-7	RMA0959	STOPPER ANGLE	[M]	A1	RQT3980-H	INSTRUCTION MANUAL	[M] (EG) <IE>
6-8	RMA0984	LOCK ANGLE	[M]	A1	RQT3981-J	INSTRUCTION MANUAL	[M] (EG) <IF>
6-9	RMS0550	STOPPER SHAFT	[M]	A1	RQT3982-K	INSTRUCTION MANUAL	[M] (GC, GH) <IG>
7	RGV0173-H	HOLD KNOB	[M]	A2	RFEA403B-S	AC ADAPTOR	[M] (EB) Δ
8	RGW0250-H	VOLUME KNOB	[M]	A2	RFEA401E-3S	AC ADAPTOR	[M] (EG) Δ
9	RHE5079YA	SCREW	[M]	A2	RFEA403Z-S	AC ADAPTOR	[M] (GC) Δ
10	RMC0306	OPEN SPRING	[M]	A2	RFEA403A-S	AC ADAPTOR	[M] (GN) Δ
11	RMG0425-H	WATER PROOF COVER(A)	[M]	A2	RFEA403H-S	AC ADAPTOR	[M] (GH) Δ
12	RMG0426-H	WATER PROOF COVER(B)	[M]	A3	RFEV703P-KS	STEREO HEADPHONES	[M]
13	RML0452	OPERATION LEVER	[M]	A4	RQA0117	WARRANTY CARD	[M] (EB, EG)
14	RML0453	VOLUME LEVER	[M]	A4	RQX7433ZA	WARRANTY CARD	[M] (GN)
15	RMX0122	WATER PROOF RING	[M]	A5	RQCB0169	SERVICENTER LIST	[M]
16	RHE5119YA	SCREW	[M]	A6	RFKFP3GAVE2S	RECHARGEABLE BATTERY ASS'Y	[M] (EB, EG)
17	RMA0960	BUCKLE ORNAMENT	[M]	A6	RFKFP3GAVT2S	RECHARGEABLE BATTERY ASS'Y	[M] (GC, GN, GH)
18	RMR1002A-S	BUCKLE (B)	[M]	A6-1	RFKNLS370-K	BATTERY CARRING CASE	[M]
19	RMR1003A-S	BUCKLE SHAFT PLATE (B)	[M]	A7	SJP5213-2	POWER PLUG ADAPTOR	[M] (GC) Δ
20	RMS0544A	BUCKLE SHAFT (B)	[M]			<PRINTED CIRCUIT BOARDS	
21	RMR1002-S	BUCKLE (A)	[M]			ASS'Y>	
22	RMR1003-S	BUCKLE SHAFT PLATE (A)	[M]	PCB1	REP2519A-M	P. C. B. ASS'Y	[M] (RTL)
23	RMS0544	BUCKLE SHAFT (A)	[M]			<GREASE OR JIG/TOOL>	
24	RGV0172-H	EXTRA ANTI-SHOCK KNOB	[M]				
25	RGV0172-K	PLAY MODE SELECTOR KNOB	[M]				
26	RGZ0030-K	OPERATION KEY TOP (A)	[M]				
27	RGZ0031-K	OPERATION KEY TOP (B)	[M]				
28	RKW0457-K	LCD PANEL (B)	[M]				
29	RMK0333A	INTERMEDEATE CHASSIS	[M]				
30	XTN17+6GFZ	SCREW	[M]				

Ref. No.	Part No.	Part Name & Description	Remarks	Ref. No.	Part No.	Part Name & Description	Remarks
		TEST DISC					
						GREASE	
SA1	SZZP1054C	PLAYABILITY TEST DISC	[M]				
SA2	SZZP1056C	UNEVEN TEST DISC	[M]				
				SA3	RFKXPG671	MOLYCOAT GREASE PG671	[M]

Notes:

- “<IA> ~ <IG>” marks in Remarks indicate language of instruction manual. [<IA>: English, <IB>: English/Spanish, <IC>: Russian/Swedish, <ID>: German/ Italy, <IE>: French/ Dutch, <IF>: Danish, <IG>: Chinese]
- The marking (RTL) indicates that the Retention Time is limited for this item. After the discontinuation of this assembly in production, the item will continue to be available for a specific period of time. The retention period of availability is dependant on the type of assembly, and in accordance with the laws governing part and product retention. After the end of this period, the assembly will no longer be available.

Supply of Rechargeable Battery Ass'y as Replacement Parts

Please take note of the following points relating to Battery Carrying Case to be used for protection of Rechargeable Battery Ass'y from shorting.

Replacement Parts:

- Rechargeable Battery Ass'y (RFKFP3GAVE2S/ RFKFP3GAVT2S) to be supplied will be provided with Battery Carrying Case (RFKNLS370-K).
- No replacement parts will be supplied for Rechargeable Battery Ass'y without Battery Carrying Case.
- Replacement parts will be supplied for Battery Carrying Case (RFKNLS370-K) without Rechargeable Battery Ass'y.
- To your customers, delivery Rechargeable Battery Ass'y together with Battery Carrying Case to prevent shorting accidents that may occur when Rechargeable Battery Ass'y is carried about without Battery Carrying Case.

Rechargeable Battery Ass'y
(Rechargeable Batteries with Carrying Case)
(RFKFP3GAVE2S/ RFKFP3GAVT2S)

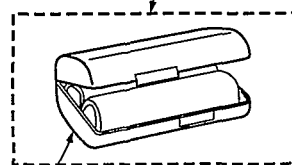

Battery Carrying Case (RFKNLS370-K)

Caution in Use of Rechargeable Battery Ass'y

- Take Rechargeable Battery Ass'y out of Battery Carrying Case and use it.
- Be sure to carry Rechargeable Battery Ass'y in this Battery Carrying Case.
If not, it may either heat or ignite by shorting with a metal.

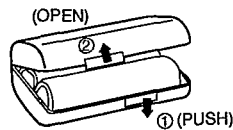

Packaging

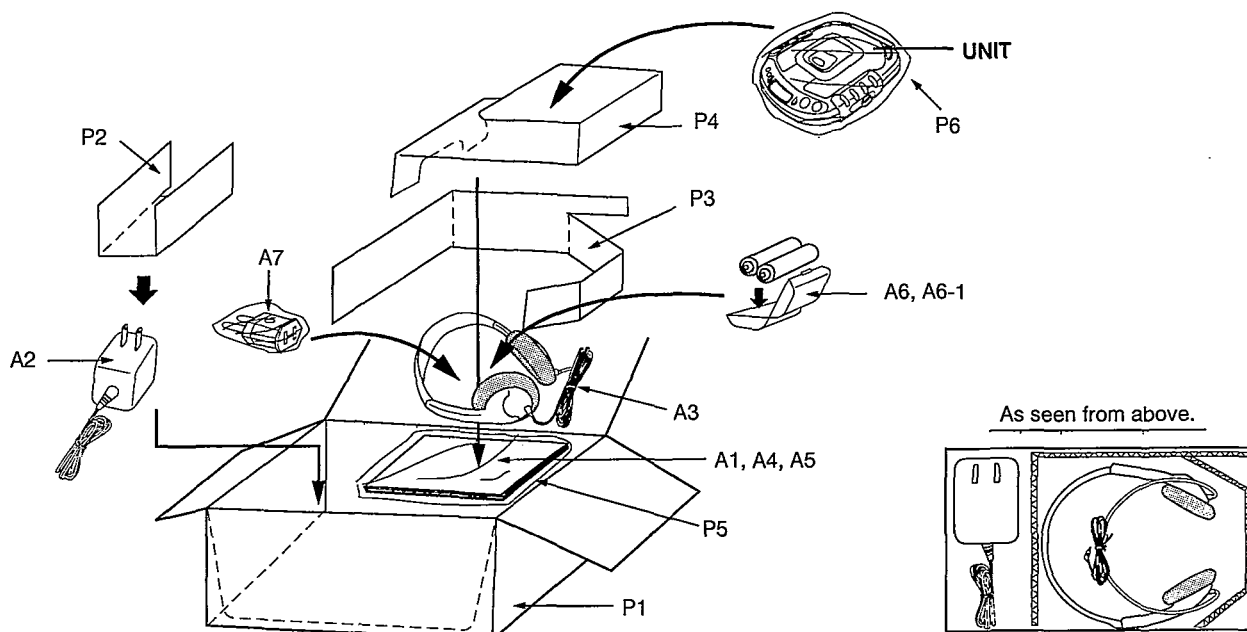

Resistors and Capacitors

Notes: * Capacity values are in microfarads (uF) unless specified otherwise, P=Pico-farads (pF) F=Farads (F)
 * Resistance values are in ohms, unless specified otherwise, 1K=1,000 (OHM), 1M=1,000k (OHM)
 * [M] indicates in Remarks columns parts that are supplied by MESA.

Ref. No.	Part No.	Values & Remarks	Ref. No.	Part No.	Values & Remarks	Ref. No.	Part No.	Values & Remarks
		RESISTORS	R603, 604	MCRO3PZHJ561	1/16W 560 [M]	C111	ECUVNC473KBV	16V 0.047U [M]
			R605, 606	ERJ3GEYJ473V	1/16W 47K [M]	C112	ECUV1H391KBV	50V 390P [M]
			R607, 608	ERJ3GEYJ102Z	3W 1K [M]	C113	ECUVNE104ZFN	25V 0.1U [M]
R11	ERJ3GEYJ103Z	1/16W 10K [M]	R609, 610	ERJ3GEYJ332V	1/16W 3.3K [M]	C114	ECUZNC104ZFV	16V 0.1U [M]
R12	ERJ3GEYJ472V	1/16W 4.7K [M]	R705, 706	ERJ3GEYJ473V	1/16W 47K [M]	C115	ECUV1C223KBV	16V 0.022U [M]
R16	ERJ3GEYJ100V	1/16W 10 [M]	R707, 708	ERJ3GEYJ223V	1/16W 22K [M]	C120	ECUV1H332KBV	50V 3300P [M]
R17	ERJ3GEYJ681V	1/16W 680 [M]	R715, 716	ERJ3GEYJ273V	1/16W 27K [M]	C121	ECUV1H221KBV	50V 220P [M]
R18	ERJ3GEYJ101V	1/16W 100 [M]	R719, 720	ERJ3GEYJ103Z	1/16W 10K [M]	C204	RCE1AKA470IG	10V 47U [M]
R22	ERJ3GEYJ822V	1/16W 8.2K [M]	R721, 722	ERJ3GEYJ223V	1/16W 22K [M]	C301, 302	ECUZNC104ZFV	16V 0.1U [M]
R25	ERJ3GEYJ104Z	1/16W 100K [M]	R723, 724	ERJ3GEYJ104Z	1/16W 100K [M]	C401	RCE1AKA470IG	10V 47U [M]
R29	ERJ3GEYJ152V	1/16W 1.5K [M]	R725, 726	ERJ3GEYJ120V	1/16W 12 [M]	C402	RCE1ASL330IX	10V 33U [M]
R30	ERJ3GEYJ154V	1/16W 150K [M]	R727, 728	ERJ3GEYJ1R5V	1/16W 1.5 [M]	C403	ECUZNC104ZFV	16V 0.1U [M]
R105	ERJ3GEYJ683V	1/16W 68K [M]	R729, 730	ERJ3GEYJ472V	1/16W 4.7K [M]	C404	ECUVNC105ZFN	16V 1U [M]
R106	ERJ3GEYJ124V	1/16W 120K [M]	R731, 732	ERJ3GEYJ331V	1/16W 330 [M]	C405	ECUV1C104KBV	16V 0.1U [M]
R113	ERJ3GEYJ101V	1/16W 100 [M]	R733, 734	ERJ3GEYJ393V	1/16W 39K [M]	C407	ECUZNC104ZFV	16V 0.1U [M]
R114	ERJ3GEYJ330V	1/16W 33 [M]	R735, 736	ERJ3GEYJ154V	1/16W 150K [M]	C408, 409	ECUVNC105ZFN	16V 1U [M]
R120	ERJ3GEYJ472V	1/16W 4.7K [M]	R737	ERJ3GEYJ683V	1/16W 68K [M]	C410	ECUV1E103KBV	25V 0.01U [M]
R121, 122	ERJ3GEYJ683V	1/16W 68K [M]	R738	ERJ3GEYJ331V	1/16W 330 [M]	C501, 502	ECUV1H050CCV	50V 5P [M]
R208	ERJ3GEYJ4R7V	1/16W 4.7 [M]	R739	ERJ3GEYJ1R5V	1/16W 1.5 [M]	C503	ECUV1H561KBV	50V 560P [M]
R209	ERJ3GEYJ223V	1/16W 22K [M]	R740	ERJ3GEYJ472V	1/16W 4.7K [M]	C505	ECUV1C223KBV	16V 0.022U [M]
R301-303	ERJ3GEYJ473V	1/16W 47K [M]	R741, 742	ERJ3GEYJ473V	1/16W 47K [M]	C506	ECUVNC224KBN	16V 0.22U [M]
R309	ERJ3GEYJ124V	1/16W 120K [M]	R743, 744	ERJ3GEYJ102Z	1/16W 1K [M]	C507	RCE0JKA221IG	6.3V 220U [M]
R313	ERJ3GEYJ102Z	1/16W 1K [M]	R920	ERJ3GEYJ473V	1/16W 47K [M]	C508, 509	ECUZNC104ZFV	16V 0.1U [M]
R316	ERJ3GEYJ102Z	1/16W 1K [M]	R928	ERJ3GEYJ473V	1/16W 47K [M]	C525	ECUZNC104ZFV	16V 0.1U [M]
R317, 318	ERJ3GEYJ104Z	1/16W 100K [M]			CHIP JUMPER(S)	C526	RCST1AY475RE	10V 4.7U [M]
R319	ERJ3GEYJ334V	1/16W 330K [M]				C532	ECUV1H102KBN	50V 1000P [M]
R400	ERJ3GEYJ182V	1/16W 1.8K [M]				C533	ECUZNC104ZFV	16V 0.1U [M]
R401	ERJ3GEYJ823V	1/16W 82K [M]	RJ502	ERJ3GEYOR00V	CHIP JUMPER [M]	C600	ECUZNC104ZFV	16V 0.1U [M]
R402	ERJ3GEYJ122V	1/16W 1.2K [M]	RJ504	ERJ3GEYOR00V	CHIP JUMPER [M]	C601, 602	ECUV1H102KBV	50V 1000P [M]
R405	ERJ3GEYJ332V	1/16W 3.3K [M]	RJ701	ERJ3GEYOR00V	CHIP JUMPER [M]	C603, 604	ECUV1H272KBV	50V 2700P [M]
R410	ERJ3GEYJ470V	1/16W 47 [M]				C605, 606	ECEA1CKA100I	16V 10U [M]
R501	ERJ3GEYJ683V	1/16W 68K [M]			CAPACITORS	C607, 608	ECUV1H681KBV	50V 680P [M]
R503	ERJ3GEYJ473V	1/16W 47K [M]	C13	RCE0JSC470IX	6.3V 47U [M]	C609	ECUZNC104ZFV	16V 0.1U [M]
R505	ERJ3GEYJ821V	1/16W 820 [M]	C14	RCE0JKA221IG	6.3V 220U [M]	C610	RCE1AKA470IG	10V 47U [M]
R506	ERJ3GEYJ681V	1/16W 680 [M]	C16	ECUVNC224KBN	16V 0.22U [M]	C703, 704	ECUV1E123KBV	25V 0.012U [M]
R507	ERJ3GEYJ1R5V	1/16W 1.5 [M]	C17	ECUV1H470KCV	50V 47P [M]	C707, 708	ECUV1H102KBV	50V 1000P [M]
R510	ERJ3GEYJ120V	1/16W 12 [M]	C18	ECUV1E103KBV	25V 0.01U [M]	C709, 710	ECEA0GPK221I	4V 220U [M]
R513	ERJ3GEYJ184V	1/16W 180K [M]	C19	ECEA1AKA220I	10V 22U [M]	C711, 712	ECEA1CPK100I	16V 10U [M]
R516	EXBV4V152JV	1/32W 1.5K [M]	C20	ECEA1HKA010I	50V 1U [M]	C713	RCE1AKA470IG	10V 47U [M]
R518	EXBV4V152JV	1/32W 1.5K [M]	C21	ECUV1C223KBV	16V 0.022U [M]	C717	ECUZNC104ZFV	16V 0.1U [M]
R520	ERJ3GEYJ152V	1/16W 1.5K [M]	C22	ECUZNC104ZFV	16V 0.1U [M]	C718	ECEA0GKA471I	4V 470U [M]
R526	ERJ3GEYJ102Z	1/16W 1K [M]	C24	ECUV1H471KBV	50V 470P [M]	C719	ECUV1H102KBV	50V 1000P [M]
R530	ERJ3GEYJ224V	1/16W 220K [M]	C25	ECEA1HKA010I	50V 1U [M]	C720	ECUVNC473KBV	16V 0.047U [M]
R531	EXBV4V103JV	1/32W 10K [M]	C27, 28	RCE1AMT331IV	10V 330U [M]	C721	ECUZNC104ZFV	16V 0.1U [M]
R533	EXBV4V103JV	1/32W 10K [M]	C32	ECUVNC105ZFN	16V 1U [M]	C722	ECEA1HKA010I	50V 1U [M]
R535	ERJ6GEYJ103V	1/10W 10K [M]	C33	ECUV1H152KBV	50V 1500P [M]	C902	ECUZNC104ZFV	16V 0.1U [M]
R536	ERJ3GEYJ103Z	1/16W 10K [M]	C101	ECUV1C104KBV	16V 0.1U [M]			
R539	ERJ3GEYJ332V	1/16W 3.3K [M]	C103	ECUV1C223KBV	16V 0.022U [M]			
R601, 602	ERJ3GEYJ681V	1/16W 680 [M]						

MEMO



MEMO

1116