

Service Manual

COMPACT
disc
DIGITAL AUDIO

DIGITAL

MASH*
multi-stage noise shaping

Portable CD Player

SL-XP160

Colour

(K)...Black Type

Area

Suffix for Model No.	Area	Colour
(E)	Europe.	(K)
(EB)	Great Britain.	
(EG)	Germany and Italy.	
(GC)	Asia, Latin America, Middle Near East and Africa.	
(GN)	Oceania.	



TRAVERSE DECK: RAE0133Z MECHANISM SERIES

- ※
- Technics (or Panasonic) developed the world's first MASH type DAC and ADC. MASH technology was invented by NTT (LSI Labs).
 - MASH is a trademark of NTT.

SPECIFICATIONS

Audio

No. of channels:	2 channels (left and right, stereo)
Output voltage:	0.6V (50k Ω) ϕ 3.5 stereo mini jack
Frequency response:	20~20,000Hz (+0.5dB, -1.5dB)
S/N:	More than 94dB
Wow and flutter:	Below measurable limit
Digital filter:	8 times over sampling
DA converter:	1 bit, MASH※
Headphone output level:	Max. 9mW+9mW/16 Ω (variable) stereo mini jack ϕ 3.5

Signal Format

Correction system:	Technics New Super Decoding Algorithm
--------------------	------------------------------------------

Pickup

Type:	One beam
Light source:	Semiconductor laser
Wavelength:	780nm
Lens:	Glass pressed lens

Play time;

(When used in hold mode, at 25°C temperature and on flat and stable surface.)

Rechargeable batteries (RP-BP60)	About 2 hours 30 minutes
Rechargeable batteries (SH-CDB8D)	About 3 hours
Panasonic Dry cell alkaline batteries (LR6)	About 8 hours

The play time may be shorter depending on the operating conditions.

Recharging time;

About 3 hours

General

Power requirement:

AC; with an included panasonic AC adaptor

(RFEA401E-1S): (E, EG)

(RFEA402Z-W): (GC)

(RFEA404A-W): (GN)

(RFEA404B-W): (EB)

Batteries; 3V (two "AA" size batteries, not included)

(Panasonic R6P/LR6 or equivalent, not included)

Rechargeable Batteries; DC 2.4V with

an optional Panasonic Rechargeable

Batteries (SH-CDB8D/RP-BP60) \times 2

Car Battery; with an optional panasonic car adaptor (SH-CDC9)

4.5V

DC IN:

Power consumption:

AC adaptor; 5.0W

Battery; 0.6W

Dimensions (W \times H \times D): 128 \times 30.3 \times 152mm

Weight: 260g without batteries

300g with batteries

Note: Design and specifications are subject to change without notice.

Weight and dimensions are approximate.

Technics®

© 1995 Matsushita Electric Industrial Co., Ltd.
All rights reserved. Unauthorized copying and distribution is a violation of law.

△ WARNING

This service information is designed for experienced repair technicians only and is not designed for use by the general public. It does not contain warnings or cautions to advise non-technical individuals of potential dangers in attempting to service a product. Products powered by electricity should be serviced or repaired only by experienced professional technicians. Any attempt to service or repair the product or products dealt with in this service information by anyone else could result in serious injury or death.

CONTENTS

Page	Page		
PRECAUTION OF LASER DIODE.....	2	CHECKING THE OPERATION PROBLEMS	
ACCESSORIES	3	ON THE TRAVERSE DECK	12
LOCATION OF CONTROLS	3	MEASUREMENTS AND ADJUSTMENTS	13, 14
USING THE UNIT WITH OPTIONAL ACCESSORIES.....	3	AUTOMATIC ADJUSTMENT RESULTS	
SEQUENTIAL PLAY.....	4	DISPLAY FUNCTION	14, 15
OTHER PLAY METHODES.....	5	BLOCK DIAGRAM.....	16~18
POWER SUPPLY PREPARATIONS	6	SCHEMATIC DIAGRAM	19~22
ACCIDENTAL OPERATION PREVENTION FUNCTION	6	PRINTED CIRCUIT BOARD AND	
CAUTIONS.....	7	WIRING CONNECTION DIAGRAM	23, 24
MAINTENANCE	7	TERMINAL GUIDE	25~28
HANDLING PRECAUTIONS FOR TRAVERSE DECK.....	8	REPLACEMENT PARTS LIST	29, 30, 32
DISASSEMBLY INSTRUCTIONS	9, 10	RESISTORS AND CAPACITORS	30
HOW TO INSTALL THE CD COVER ASS'Y.....	10	CABINET PARTS LOCATION.....	31
HOW TO INSTALL THE SWITCH KNOB	11	PACKAGING	32
HOW TO CHECK THE P.C.B.	11		

PRECAUTION OF LASER DIODE

CAUTION: This product utilizes a laser diode with the unit turned "on", invisible laser radiation is emitted from the pickup lens.

Wave length: 780nm

Maximum output radiation power from pickup: 100μW/VDE

Laser radiation from the pickup lens is safety level, but be sure the followings:

1. Do not disassemble the optical pickup unit, since radiation from exposed laser diode is dangerous.
2. Do not adjust the variable resistor on the pickup unit. It was already adjusted.
3. Do not look at the focus lens using optical instruments.
4. Recommend not to look at pickup lens for a long time.

ACHTUNG: Dieses Produkt enthält eine Laserdiode. Im eingeschalteten Zustand wird unsichtbare Laserstrahlung von der Lasereinheit abgestrahlt.

Wellenlänge: 780nm

Maximale Strahlungsleistung der Lasereinheit: 100μW/VDE

Die Strahlung an der Lasereinheit ist ungefährlich, wenn folgende Punkte beachtet werden:

1. Die Lasereinheit nicht zerlegen, da die Strahlung an der freigelegten Laserdiode gefährlich ist.
2. Den werkseitig justierten Einstellregler der Lasereinheit nicht verstellen.
3. Nicht mit optischen Instrumenten in die Fokussierlines blicken.
4. Nicht über längere Zeit in die Fokussierlines blicken.

ADVARSEL: I dette a apparat anvendes laser.

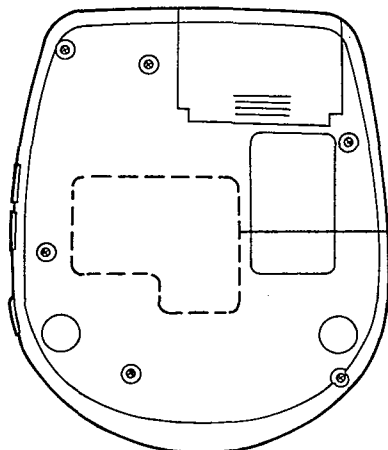

(Bottom side)

RQLS0077-2

CLASS 1 LASER PRODUCT	
ADVARSEL: USYNLIG LASERSTRÅLING VED ÅBNING, NÅR SIKKERHEDSAF- BRYDERE ER UDE AF FUNKTION. UNDGÅ UDSÆTTELSE FOR STRÅLING.	
VORSICHT: Unsichtbare Laserstrahlung, wenn Abdeckung geöffnet und Sicherheitsverriegelung überbrückt. Nicht dem Strahl aussetzen.	DANGER: Invisible laser radiation when open and interlock defeated. AVOID DIRECT EX- POSURE TO BEAM.
VARO! Avattaessa ja suojalukitus ohitettaessa olet alttiina näkymätön lasersäteilylle. Älä katso säteeseen.	WARNING! Osynlig laserstråling når denna del är öppnad och spårren är urkopplad. Betrakta ej strålen.
ADVARSEL! Usynlig laserstråling når deksel åpnes og sikkerhedsstås brytes. Unngå eksponering for strålen. RQLS0077-2	

ACCESSORIES

AC adaptor..... 1 pc.
[For (EB) area.]
(RFEA404B-W)

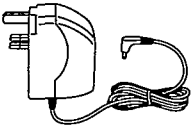

Power plug adaptor..... 1 pc.
[For (GC) area.]
(SJP9223-1)



[For (E, EG) areas.]
(RFEA401E-1S)

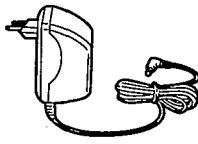

Stereo earphones
(RFEV310A-KS)..... 1 pc.

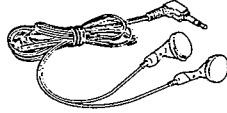

[For (GN) area.]
(RFEA404A-W)

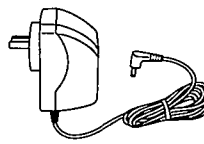

[For (GC) area.]
(RFEA402Z-W)

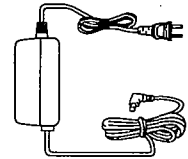

LOCATION OF CONTROLS

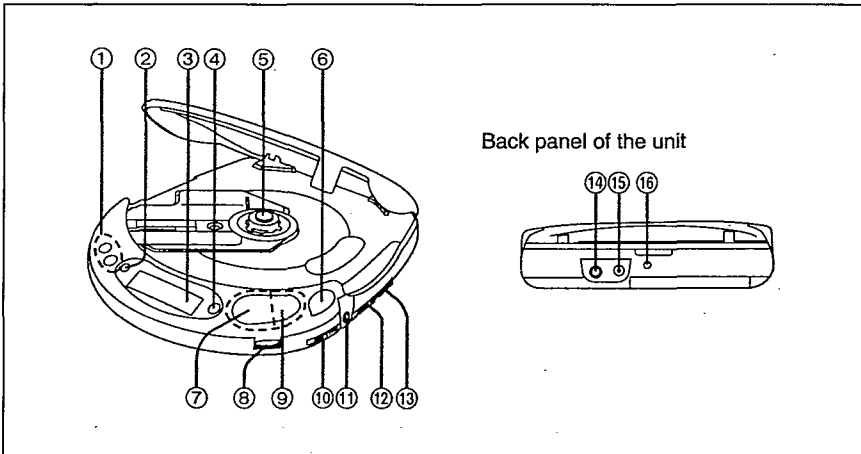

- ① Skip/search buttons (◀◀ -SKIP/-SEARCH ▶▶)
- ② Memory/recall button (MEMORY/RECALL)
- ③ Display
- ④ Repeat button (REPEAT)
- ⑤ Push button (PUSH)
- ⑥ Open button (OPEN)
- ⑦ Play/pause button (▶||)
- ⑧ Headphones volume control (VOLUME)
- ⑨ Stop/operation off button (■/OPR OFF)
- ⑩ XBS switch(XBS)
- ⑪ Headphones jack (Ⓜ) 16Ω φ3.5
- ⑫ Play mode selector (MODE)
- ⑬ Hold switch (HOLD)
- ⑭ Out jack (OUT)
- ⑮ DC in jack (DC IN 4.5 V ⚡)
- ⑯ Hole for car insulator mounting screw

USING THE UNIT WITH OPTIONAL ACCESSORIES

Using the unit with an audio system **A**

Using the stereo connection cable, you can hear CDs on your audio system.

- Connect the cable to the amplifier after turning off its power.
- Do not connect the cable to the PHONO jacks on the amplifier.
- Obtain the optional connecting cable if the amplifier comes with mini-phone jacks.
- Adjust the volume level on the amplifier.

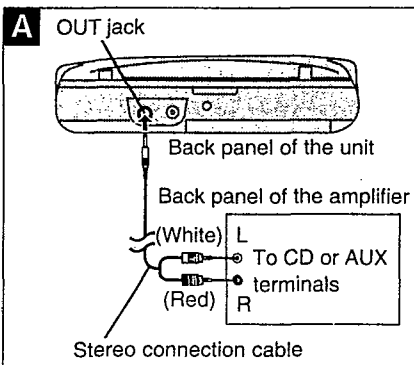

Using the unit with a car audio system

Obtain the car mounting kit.

Items to be purchased

For connection to the car audio system:
Car stereo cassette adaptor (SH-CDM9D) **A**

For securing the unit and connecting the power supply:

- Car adaptor (SH-CDC9) **B**
- Car mounting kit (SH-CDF7)
- Car mounting arm **C**, Car insulator **D**

Note

It may not be possible to use the unit with some types of car audio systems owing to restrictions imposed by the construction of the car stereo cassette adaptor. For further details, refer to the instructions of the part concerned.

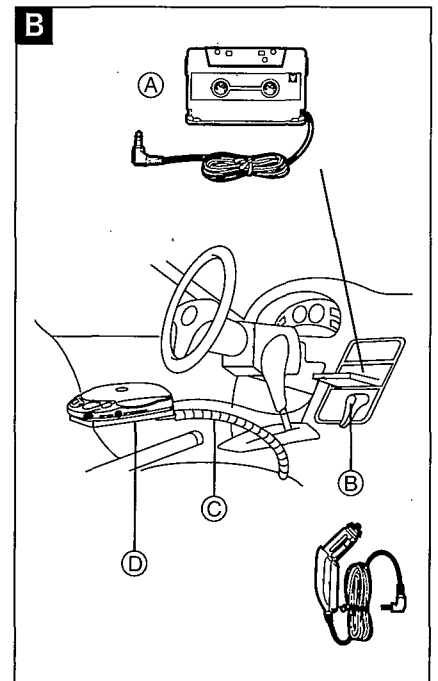

SEQUENTIAL PLAY

1 Press OPEN to open the lid, and insert the disc.

Label must face upward.
 Press the area near the center hole of the disc until it clicks into position.
 Close the lid.

2 Release the hold mode.

3 Set MODE to NORMAL.

4 Connect the stereo earphones to the jack. 16Ω φ3.5
 (Plug in firmly)

5 Press ► II.
 Play now starts.

Track number in play
 Elapsed playing time of each track

6 Adjust the volume level.
 (If the unit has been connected to the car audio system, adjust the volume level on the system.)

Removing the disc

After the disc has stopped rotating, press PUSH and release the disc. (Do not open the lid during play.)

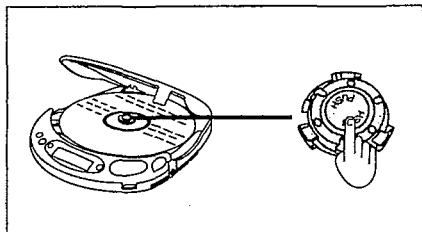

Skip and search functions

- During program play the tracks are skipped in the forward or backward direction in the programmed sequence.
- During program play, random play or 1-track repeat play, only the track being played is searched.
- During random play, it is not possible to skip to the track which has already been played.

For your reference:

“no disc” display

This appears for about 30 seconds when a disc has not been inserted or when a disc has not been inserted properly and then ► II is pressed.

“OPEN” display

This appears for about 10 minutes after the lid is opened. (It does not appear when the unit is turned off.)

Automatic Shut-OFF function

When the unit is left for about 10 minutes in the stop or pause mode, this function automatically shuts off the power in order to prevent the rechargeable batteries, etc. from discharging needlessly.

Operation	Button	Display
Pause: press during play/press again to resume play	► II	1 7:35
To stop play: press during play <input type="button" value="Stop mode"/>	■	Total number of tracks 7 49:58 Total playing time
To turn off the unit: press during stop mode <input type="button" value="Off mode"/>	■	<input type="text"/>
Skip forward/backward (skip function): press during play Rapid forward/backward (search function): keep depressed during play	►►: Forward direction ◄◄: Backward direction	<input type="text"/>

OTHER PLAY METHODES

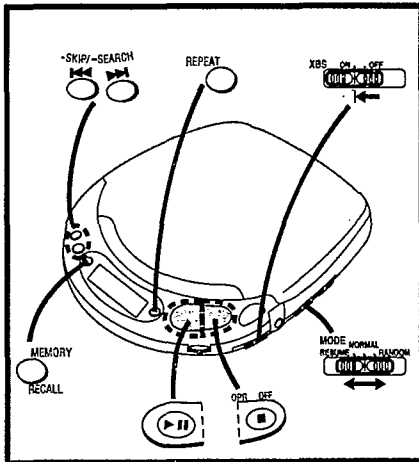

Skip play

Preparation:

Set the unit to the stop mode.

- 1 Set **MODE** to **NORMAL**.
- 2 Press **-SKIP/-SEARCH** to select the desired track number.
- 3 Press **▶ II**.

The tracks are played in sequence starting with the selected track until the last track, after which play is automatically stopped.

Resume play

Set **MODE** to **RESUME**.

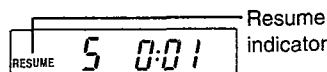

Play can be resumed from the start of the track which was playing when the stop mode was last selected or when the power was last turned off.

This is useful when playing discs inside a car.

To cancel the resume mode

Set **MODE** to **NORMAL**.

For your reference:

If **MODE** is set to **RESUME** while the unit is turned off, the all repeat function is automatically activated when play is started.

Notes

- If play is stopped near the end of a track, it may be resumed from the next track.
- When the unit is turned off during play and the disc is replaced, play will start at the same position midway through the corresponding track on the new disc since the position of the track which was previously played is still in the memory.

To change the tone quality

(Available only when listening through the stereo earphones.)

XBS:

- ON:** For extra bass sound
OFF: To cancel the XBS mode

Program play

Up to 24 tracks can be programmed.

Preparation:

Set the unit to the stop mode.

- 1 Set **MODE** to **NORMAL**.
- 2 Press **-SKIP/-SEARCH** to select the desired track number.
 For example:
 To select track 3, press **▶▶** 3 times.

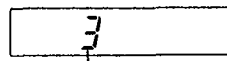

Track number

- 3 Press **MEMORY/RECALL** to store the number in the memory.

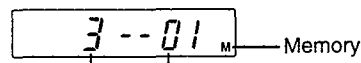

Track number

Program order

- 4 Repeat steps 2 and 3 to program all the desired tracks.
- 5 Press **▶ II**.

To program the same track repeatedly

Press **MEMORY/RECALL** repeatedly after step 3.

When "F" appears

No more tracks can be programmed.

To check what has been programmed

Press **MEMORY/RECALL** during play. (The display shows the programmed track numbers in the sequence you have entered.)

To cancel all the programming

Press **■/OPR OFF**.

Random play

- 1 Set **MODE** to **RANDOM**.
- 2 Press **▶ II**.

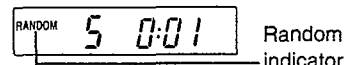

To cancel the random mode

Set **MODE** to **NORMAL**.

For your reference:

The first track to be played can be changed by pressing **▶▶** in the stop mode. (All the tracks are played regardless of the track first played.)

Note

Program play is not possible in the **RANDOM** mode.

Repeat function

To repeat one track

Press **REPEAT** once in the stop mode or during play.

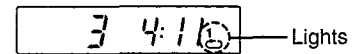

To repeat all the tracks

Press **REPEAT** twice in the stop mode or during play. (In the program play mode, only all the programmed tracks will be repeated.)

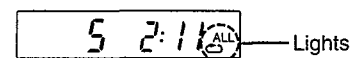

To cancel the repeat function

Press **REPEAT** once in the all repeat mode.

POWER SUPPLY PREPARATIONS

Refer to the specifications for the duration of the play time provided when rechargeable or dry cell batteries are used.

Using rechargeable batteries

Obtain the optional rechargeable batteries (SH-CDB8D/RP-BP60) for SL-XP160. Make sure that the rechargeable batteries have been recharged before use.

Recharging procedure

- 1 Place the rechargeable batteries inside the unit.
(No batteries other than SH-CDB8D/RP-BP60 can be recharged.)

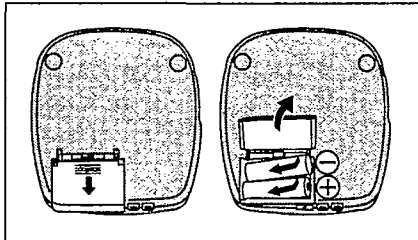

If the battery compartment lid becomes disengaged, position it horizontally and press it back into position.

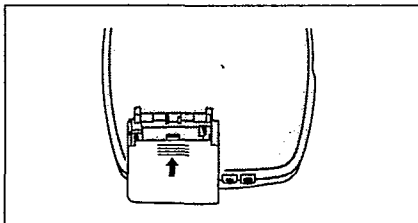

- 2 Connect the AC adaptor.

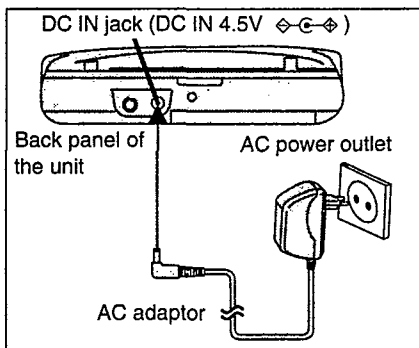

Note

The configuration of the AC adaptor differs according to the area.

- It takes about 3 hours to fully recharge the batteries.

- 3 Upon completion of the recharging, disconnect the AC adaptor from the DC IN jack and power outlet.

Removing the batteries

Push the batteries upward in the direction of the arrow to remove them.

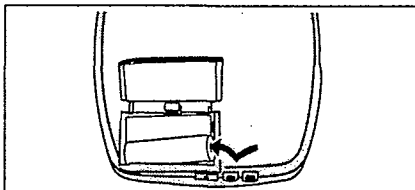

- The batteries can be used for about 10 months (300 times) if they are used every day. They will need to be replaced if the duration of their operation drops drastically.
- You can operate the unit with the AC adaptor while recharging the batteries, but it will lengthen the recharging time.
- Recharging should be performed at 0°C~40°C.
- While recharging, the AC adaptor and rechargeable batteries may get warm. This is normal.

Using dry cell batteries (not included)

Disconnect the AC adaptor and then install two LR6 (UM-3) type alkaline batteries.

The batteries are inserted and removed in the same way as for the rechargeable batteries.

Using the AC adaptor

Connect the AC adaptor supplied.

Refer to the section on "Using the rechargeable batteries" for details on the connections.

Note

The unit is in the standby condition when the AC adaptor is connected. The primary circuit is always "live" as long as the AC adaptor is connected to an electrical outlet.

Using the car adaptor (not included)

Be sure to obtain the car adaptor (SH-CDC9), available as an optional accessory.

The batteries can be recharged inside the car using the car adaptor.

Battery indicator

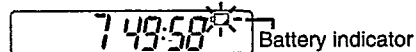

This starts flashing when the batteries have run down, and after a short while the power is automatically cut off.

(The amount of time during which play continues after the indicator has started flashing differs slightly depending on the type of batteries used.)

Type of battery	Action
Rechargeable batteries	Recharge the batteries again.
Dry cell batteries	Replace with new batteries.

(The battery indicator may not flash if rechargeable batteries, other than those designated by our company, are used.)

ACCIDENTAL OPERATION PREVENTION FUNCTION

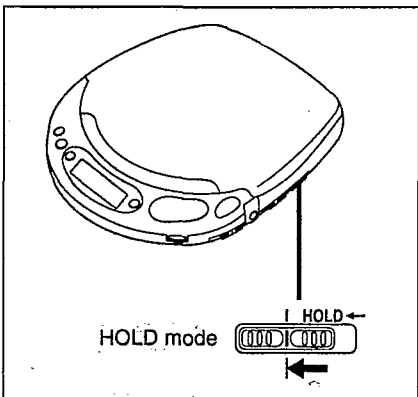

This function prevents the unit from operating even if a control button is pressed in error. (The disc lid can still be opened and closed.)

Use the function to prevent the following situations:

Example 1:

While the unit is not in use, the power is inadvertently turned on and the batteries run down.

Example 2:

Play is interrupted while the unit is in use.

To use the accidental operation prevention function

Set HOLD to the HOLD position.

"hold" indicator

If the unit is in the hold mode, the "hold" indicator appears when any of the unit's function buttons (except OPEN button) is pressed.

When the unit is turned off

The "hold" indicator appears only when ►II is pressed.

Before operating the buttons

Be absolutely sure to move HOLD to release the unit from the hold mode.

CAUTIONS

AC adaptor

- Handle the AC adaptor carefully. Improper handling is dangerous.
 - Do not touch it with wet hands.
 - Do not place heavy objects on top of it.
 - Do not forcibly bend it.
- Be sure to connect only the AC adaptor provided with the unit.
- Disconnect the AC adaptor from the power outlet if the unit is not going to be used for a long time.

Unit

No altering or remodeling

This can cause malfunctioning.

No dropping or strong impacts

This may damage the unit.

Locations to be avoided

Avoid using the unit in the following locations since they can cause malfunctioning.

1. Bathrooms and other moisture-prone places
2. Warehouses and other dusty places
3. Very hot places near heating appliances, etc.

Do not leave the unit exposed to direct sunlight for long periods of time

This may deform or discolor the cabinet and may also cause malfunctioning.

Rechargeable batteries

- Only the (SH-CDB8D/RP-BP60) batteries can be recharged.
- If the power delivered by the batteries lasts for a very short time after recharging, it means that the batteries' service life is over. Do not use them any more.
- Recharging already charged batteries will shorten their service life.
- When recharging batteries for the first time or when they have not been used for a long period of time, the play time may be shorter than usual. In a case like this, repeatedly recharge and discharge the batteries. This will restore them to their regular state.
- Do not allow any metal objects to touch the terminals of rechargeable batteries since this may cause short-circuiting which is dangerous.

Dry cell batteries/rechargeable batteries

To prevent damage to the batteries and electrolyte leakage, heed the following points.

- Align the ⊕ and ⊖ polarities properly when inserting the batteries.
- Do not mix different types or makes of batteries or old and new batteries.
- Remove the batteries if you do not plan to use the unit for a long period of time.
- Do not throw batteries into a fire, and do not short-circuit, disassemble or subject them to excessive heat.
- Do not attempt to recharge dry cell batteries.
- Do not peel off the plastic covering on the rechargeable batteries. Short-circuiting may occur which is dangerous.

Carrying dry cell batteries/rechargeable batteries around

When putting dry cell or rechargeable batteries in a pocket or bag, ensure that no other metal objects such as a necklace are placed together with them. Contact with metal may cause short-circuiting which, in turn, may cause a fire. Be absolutely sure to carry the rechargeable batteries in the battery carrying case.

When driving a car

In the interest of traffic safety, do not operate the unit while driving.

Precautions for Listening with the Headphones

- Do not play your headset at a high volume. Hearing experts advise against continuous extended play.
- If you experience a ringing in your ears, reduce volume or discontinue use.
- Do not use while operating a motorized vehicle. It may create a traffic hazard and is illegal in many areas.
- You should use extreme caution or temporarily discontinue use in potentially hazardous situations.
- Even if your headset is an open-air type designed to let you hear outside sounds, don't turn up the volume so high that you can't hear what's around you.

When purchasing rechargeable batteries

As a safety precaution, the portable CD players made by Panasonic have a construction designed to make it impossible to recharge ordinary batteries.

To use rechargeable batteries, be absolutely sure to purchase the rechargeable Ni-Cd batteries designed especially for this unit.

Special rechargeable Ni-Cd batteries: SH-CDB8D (set of 2)

For details, check with your dealer.

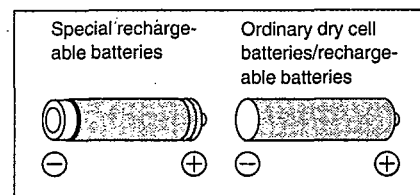

Notice about the rechargeable battery

The battery is designated recyclable. Please follow your local recycling regulations.

MAINTENANCE

Maintaining the unit

Wipe the unit with a soft cloth. Remove stubborn dirt using a cloth which has been dipped in water or soapy water and wrung out, and then wipe dry.

- If you intend to use a chemical cleaning cloth, read its directions first.
- Do not use alcohol or paint thinners.

Maintaining the lens

Open the lid and clean the lens as shown in the figure.

Use a cotton swab to gently wipe off any fingerprints.

Recommended product: Lens cleaner kit

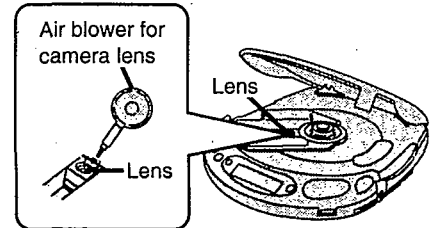

HANDLING PRECAUTIONS FOR TRAVERSE DECK

The laser diode in the traverse deck (optical pickup) may break down due to potential difference caused by static electricity of clothes or human body.

So, be careful of electrostatic breakdown during repair of the traverse deck (optical pickup).

• Handling of traverse deck (optical pickup)

1. Do not subject the traverse deck (optical pickup) to static electricity as it is extremely sensitive to electrical shock.
2. To prevent the breakdown of the laser diode, an antistatic shorting pin is inserted into the flexible board (FFC).
When removing or connecting the short pin, finish the job in as short time as possible.
3. Take care not to apply excessive stress to the flexible board (FFC).
4. Do not turn the variable resistor (laser power adjustment). It has already been adjusted.

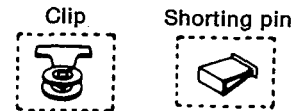
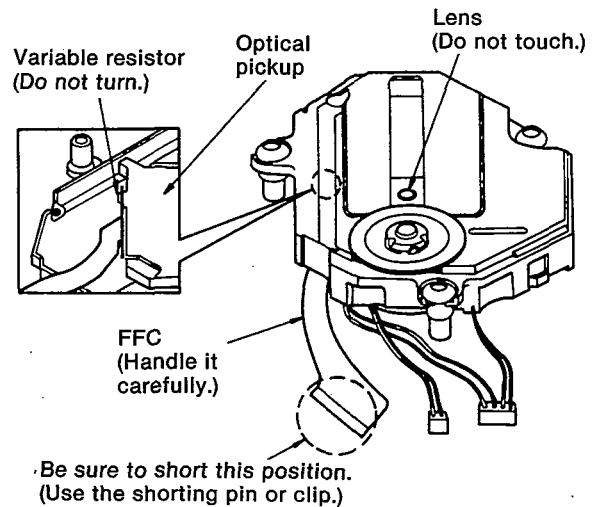

• Grounding for electrostatic breakdown prevention

1. Human body grounding.
Use the anti-static wrist strap to discharge the static electricity from your body.
2. Work table grounding
Put a conductive material (sheet) or steel sheet on the area where the traverse deck (optical pickup) is placed, and ground the sheet.

Caution:

The static electricity of your clothes will not be grounded through the wrist strap. So, take care not to let your clothes touch the traverse deck (optical pickup).

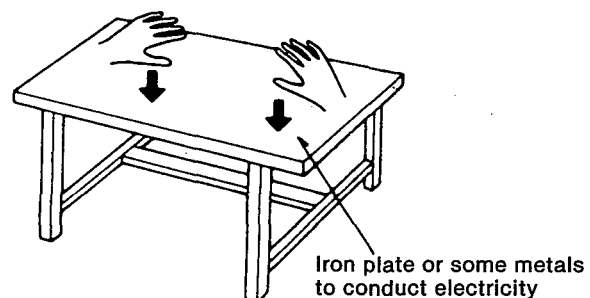
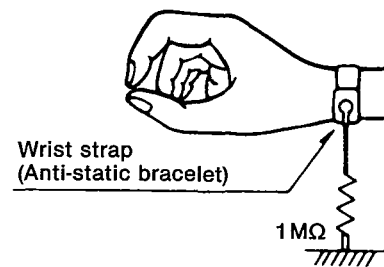

DISASSEMBLY INSTRUCTIONS



Warning: This product uses a laser diode. Refer to caution statements on page 2.

ACHTUNG: •Die Lasereinheit nicht zerlegen.

•Die Lasereinheit darf nur gegen eine vom hersteller spezifizierte einheit ausgetauscht werden.

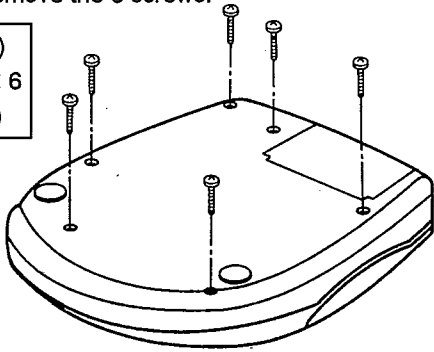
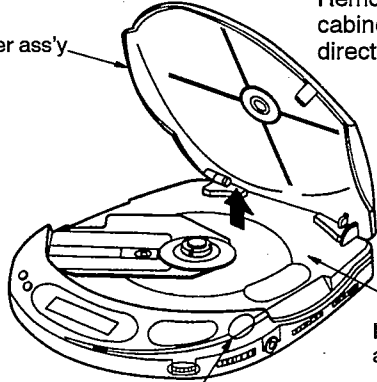
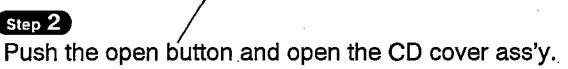
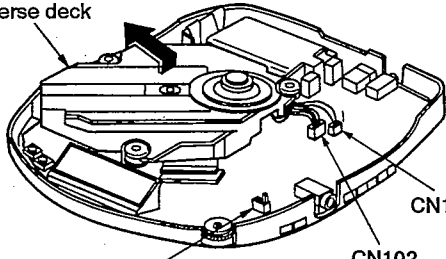
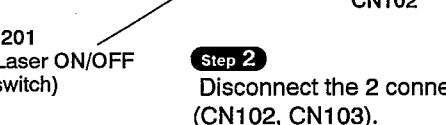
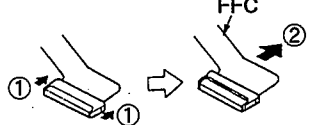
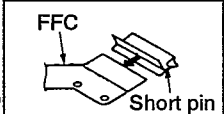
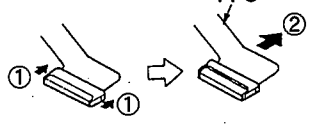
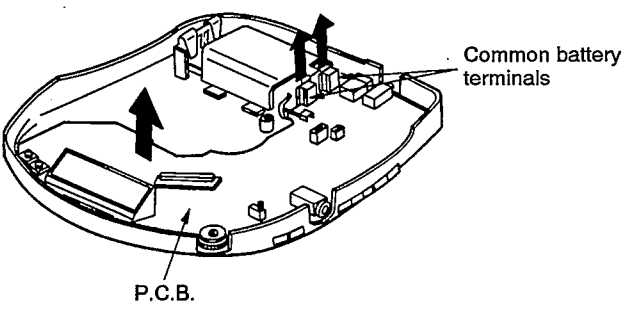
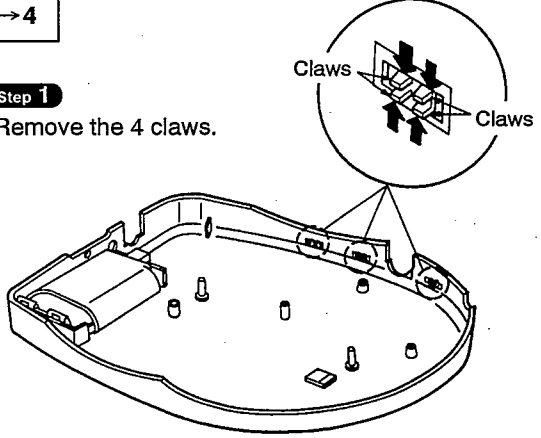
※ This CD player is equipped with FPC boards, so handle them with care during disassembly and reassembly.

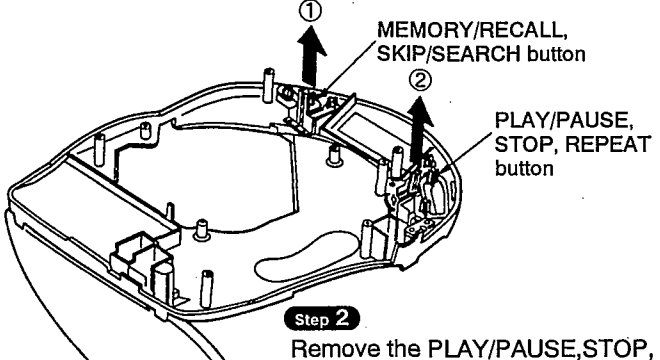
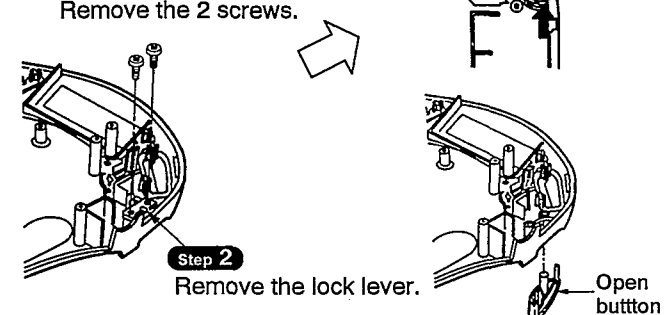
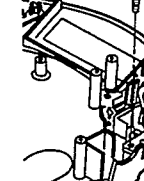
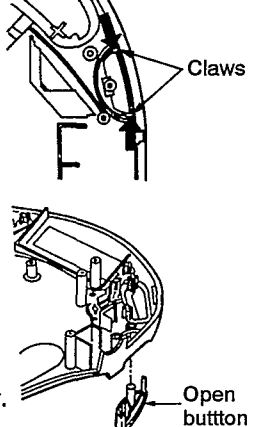
<p>Ref.No. 1</p>	<p>Removal of the intermediate cabinet ass'y</p>	<p>Step 1 Remove the 6 screws.</p>  <p>(6 pcs.) Tapping screw 1.7 × 6 (Black)</p> <p>Step 2 Push the open button and open the CD cover ass'y.</p>  <p>Step 3 Remove the intermediate cabinet ass'y in the direction of arrow.</p> 	
<p>Ref.No. 2</p>	<p>Removal of the traverse deck</p>	<p>Procedure 1 → 2</p> <p>Step 1 Pull out the traverse deck in the direction of arrow.</p>  <p>Step 2 Disconnect the 2 connectors (CN102, CN103).</p>  <p>Step 3 Remove the FFC (CN101).</p>  <p>Caution: Insert a short pin into the traverse deck's FFC. (Refer to "handling precautions for traverse deck" on page 8.)</p>  <p>1. Push the top of the connector in the direction of arrow ①. 2. Remove the FFC in the direction of arrow ②.</p> 	
<p>Ref.No. 3</p>	<p>Removal of the P.C.B.</p>	<p>Ref.No. 4</p>	<p>Removal of the switch knob (XBS/HOLD/P.MODE)</p>
<p>Procedure 1 → 2 → 3</p> <p>Step 1 Remove the P.C.B. and common battery terminals in the direction of arrow.</p>  <p>Common battery terminals</p> <p>P.C.B.</p>		<p>Procedure 1 → 2 → 3 → 4</p> <p>Step 1 Remove the 4 claws.</p>  <p>Claws</p> <p>Claws</p>	

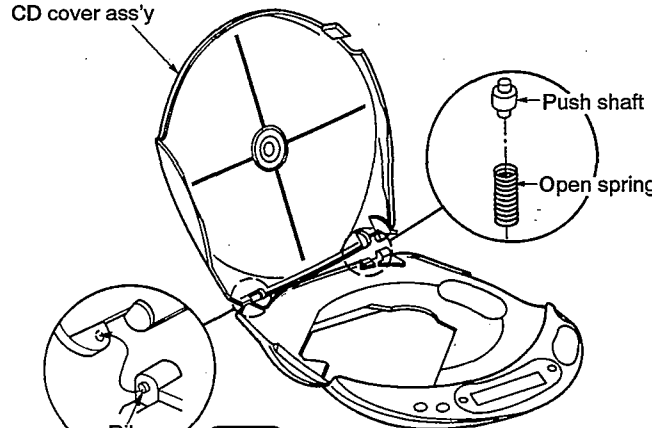
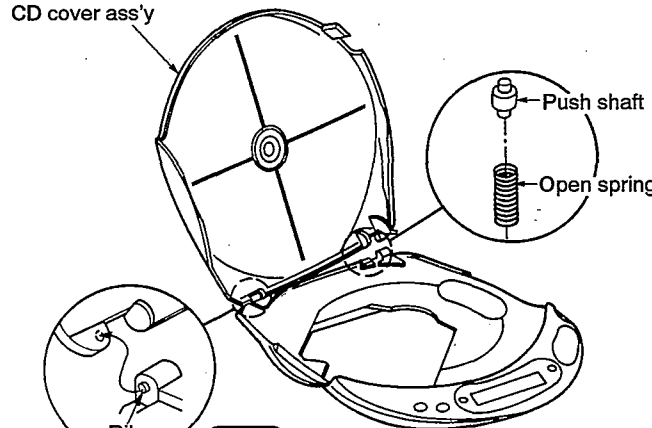
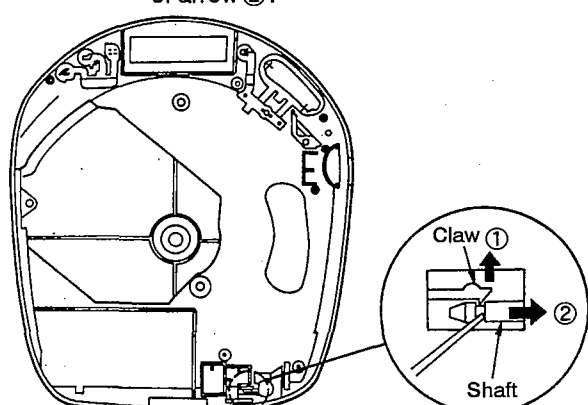
<p>Ref.No. 5</p>	<p>Removal of the MEMORY/RECALL, SKIP/SEARCH button and PLAY/PAUSE, STOP, REPEAT button</p>	<p>Ref.No. 6</p>	<p>Removal of the open button and lock lever</p>
<p>Procedure 1→5</p>	<p>Step 1 Remove the MEMORY/RECALL, SKIP/SEARCH button in the direction of arrow ①.</p>  <p>Step 2 Remove the PLAY/PAUSE, STOP, REPEAT button in the direction of arrow ②.</p>	<p>Procedure 1→6</p> <p>Step 1 Remove the 2 screws.</p>  <p>Step 2 Remove the lock lever.</p>  <p>Step 3 Release the 2 claws, and then remove the open button.</p>  <p> (2 pcs.) Tapping screw (Black)</p>	<p>※ When the CD cover ass'y is removed, the push shaft and the open spring will also be removed. Be careful not to loose them.</p>  <p>Step 2 Remove the CD cover ass'y from rib.</p>
<p>Ref.No. 7</p>	<p>Removal of the CD cover ass'y</p>	<p>※ When the CD cover ass'y is removed, the push shaft and the open spring will also be removed. Be careful not to loose them.</p>  <p>Step 2 Remove the CD cover ass'y from rib.</p>	
<p>Procedure 1→7</p>	<p>Step 1 Push the claw in the direction of arrow ①, and then remove the shaft in the direction of arrow ②.</p> 		

HOW TO INSTALL THE CD COVER ASS'Y

- Step 1** Align the open spring and the push shaft with the hole of intermediate cabinet ass'y.
- Step 2** Install the CD cover ass'y to the intermediate cabinet ass'y.

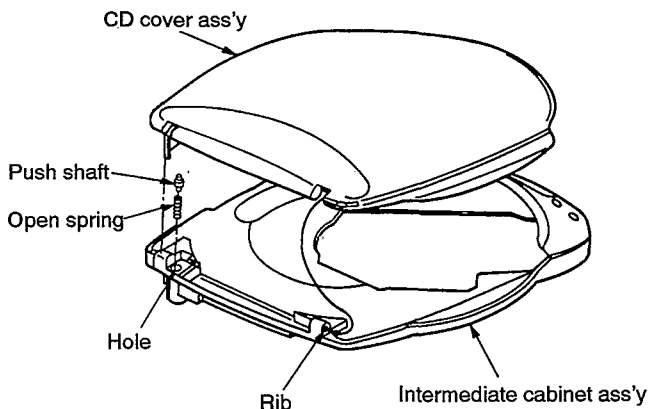

- Step 3** Holding the CD cover ass'y not to be detached the open spring and the push shaft, install the shaft.

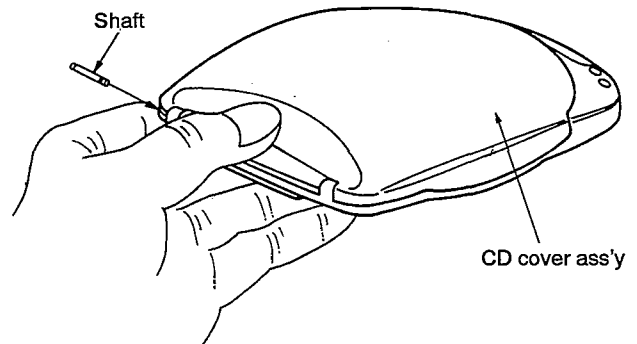

HOW TO INSTALL THE SWITCH KNOB

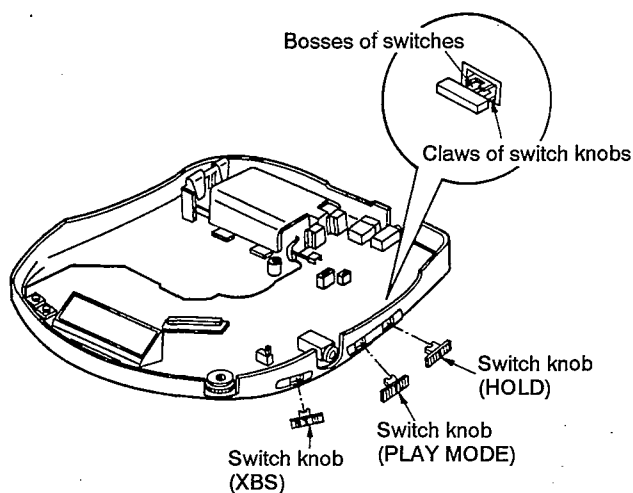

- Make sure the bosses of the switches are fit in the claws of switch knobs when inserting the switch knob.

※ Before installing the switch knob, be sure to check the claws for defects that would render the claws unserviceable. (If a white line like white wax on a claw is found, the claw may be broken when installing the switch knob.)

HOW TO CHECK THE P.C.B.

1. Remove the intermediate cabinet ass'y. (See Ref.No.1 of the disassembly instructions.)

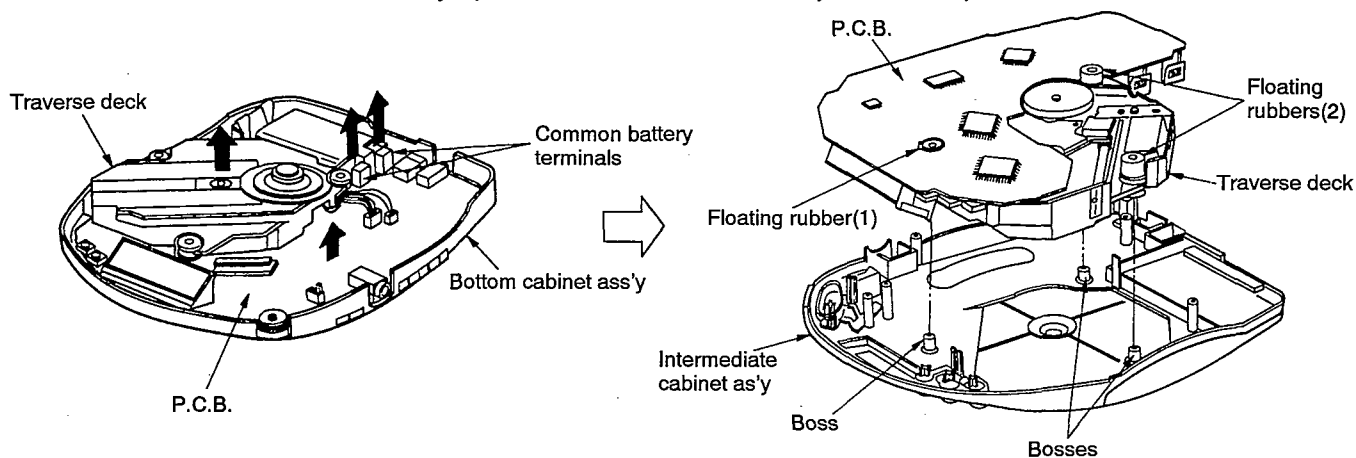

2. Remove the traverse deck, P.C.B. and common battery terminals from the bottom cabinet ass'y.

3. Install the traverse deck and P.C.B. in the intermediate cabinet ass'y.

Note: Engage the floating rubbers of the traverse deck in the bosses on the intermediate cabinet ass'y.

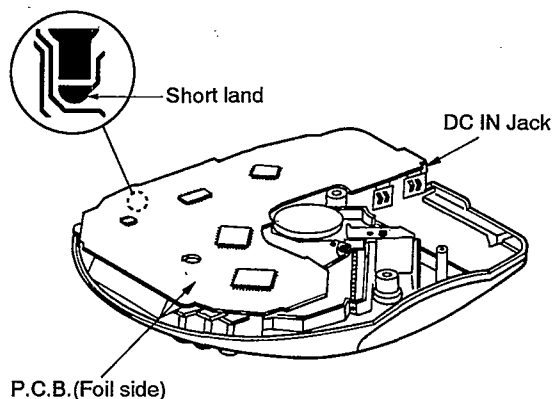

7. Short the short land of the laser ON/OFF SW(S201) by soldering it. (See page 13.)

Note: After checking the P.C.B., remove the solder from the short land.

8. With the P.C.B. in place as shown in the figure right, connect the AC adaptor to the DC IN Jack, press the play button and then measure the voltage and waveform.

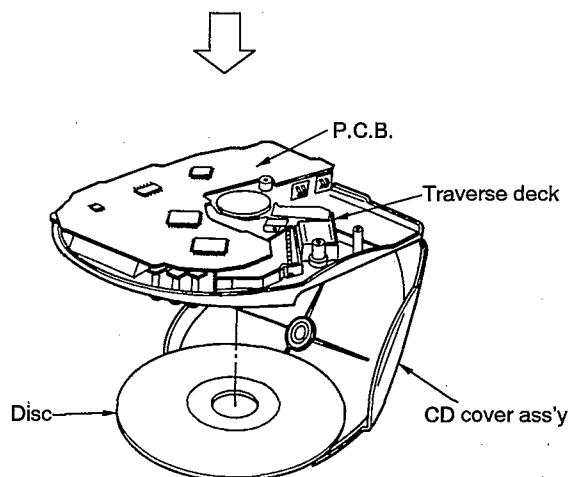

4. Open the CD cover ass'y.
5. Install the unit in place by holding the traverse deck and P.C.B. firmly, and then install the disc.
6. Close the CD cover ass'y.

■ CHECKING THE OPERATION PROBLEMS ON THE TRAVERSE DECK (OPTICAL PICKUP)

Make sure to follow the procedures below to check the operation problems of the traverse deck (optical pickup) before replacing it. Replace the traverse deck only after the problem is identified.

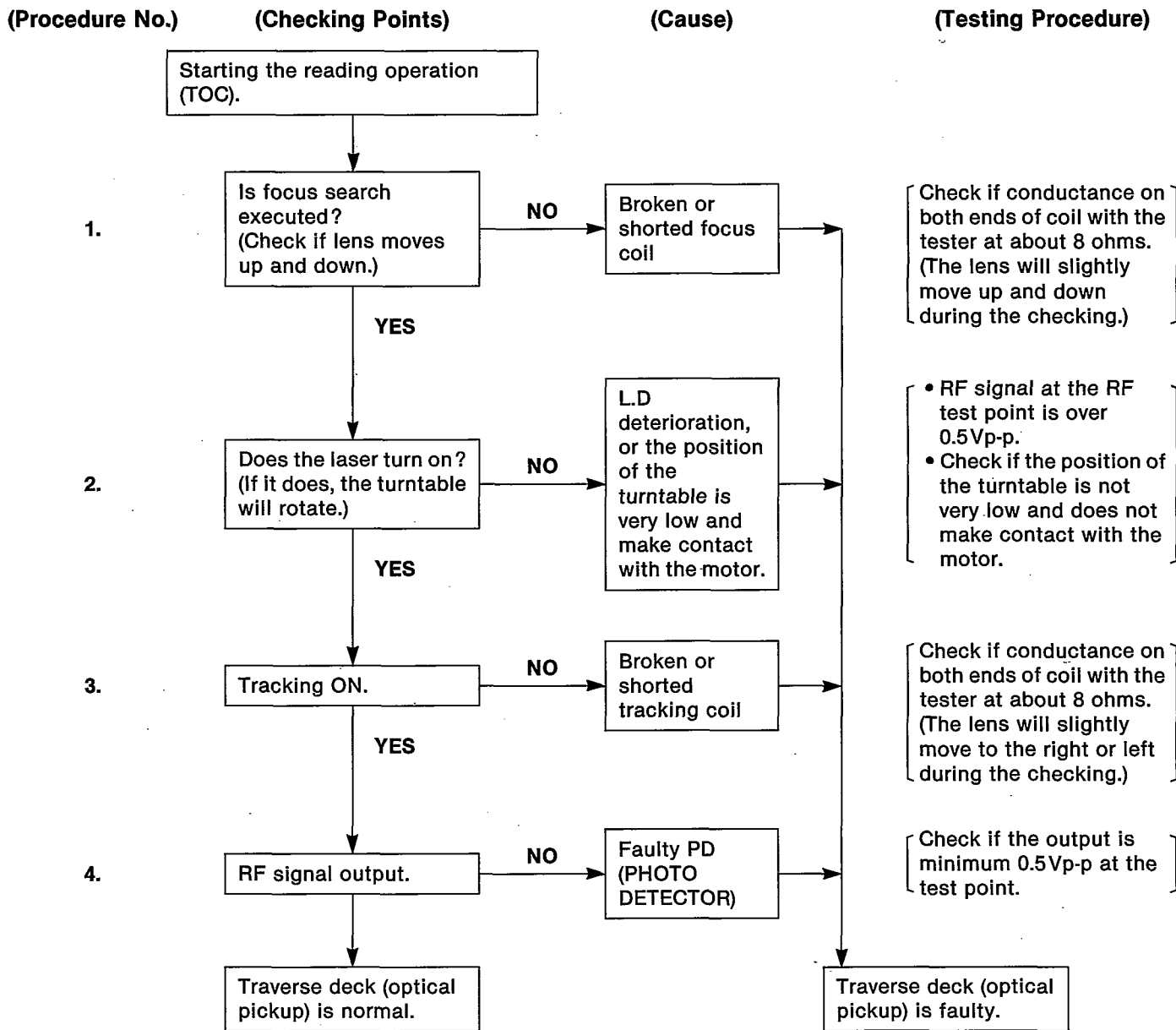

※ Replace traverse deck.

- Check electrical circuit.
- Check for flaws on disc or if it is warped or not centered.

• Check the operations described below on the traverse deck after replacing it.

* Checking Skip Search

1. Play an ordinary musical program disc.
2. Press the skip button to check for normal skip search operation (in both the forward and reverse directions).

* Checking Manual Search

1. Play an ordinary musical program disc.
2. Press the manual search button to check for smooth manual search operations at either low or high speed (in both the forward and reverse directions).

* Checking Playability

1. Play the 0.7mm black dot and the 0.7mm wedge on the playability test disc (SZZP1054C) and verify that no sound skip or noise occurs.
2. Play the middle tracks of the uneven test disc (SZZP1056C) and verify that no sound skip or noise occurs.

MEASUREMENTS AND ADJUSTMENTS

Warning: This product uses a laser diode. Refer to caution statements on page 2.

ACHTUNG: • Die lasereinheit nicht zerlegen.

- Die lasereinheit darf nur gegen eine vom hersteller spezifizierte einheit ausgetauscht werden.

Measuring instruments and special tools

Test discs

1. Playability test disc (SZZP1054C)
2. Uneven test disc (SZZP1056C)

- Allen wrench (M2.0) (SZZP1101C)
- Lock paint (RZZ0L01)
- Musical program disc (ordinary)
- DC voltmeter
- Lead wire (for test points)

Test short land

Short-circuit the lands of the laser ON/OFF switch (S201) by soldering them. It turns "ON" position. (Refer to below figure or printed circuit board and wiring connection diagram for short land location on pages 23, 24.)

Note: Remove the solders from the lands after adjustment.

Adjustment point

- Notes:** 1. Please refer to the printed circuit board and wiring connection diagram for test point locations.
2. Take care to connect CN101.

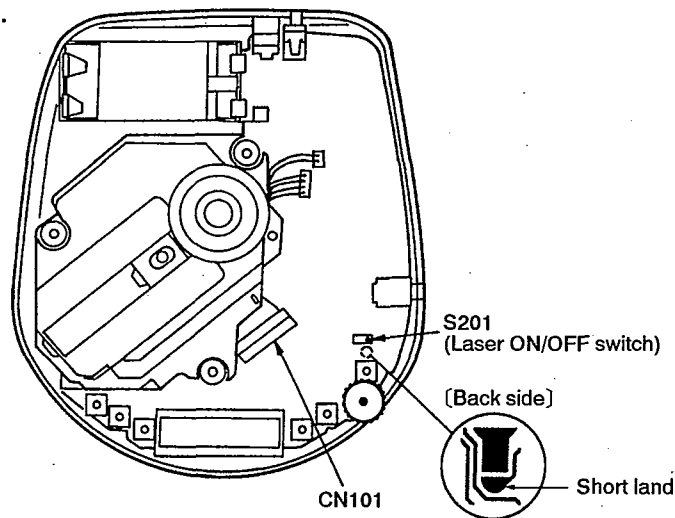

Adjustment procedure

(1) MECHANICAL ADJUSTMENT

- When the traverse deck is replaced, making adjustments is not necessary. (The traverse deck ass'y is already adjusted.)
- Make adjustments to improve playability if the traverse deck has not been replaced.

1. Connect the oscilloscope's CH. 1 probe across **TP1** (RF) (+) and **TP4** (GND) (-) on the P.C.B.

Oscilloscope setting: VOLT 100mV
SWEEP 0.5 μ s.
Input coupling AC

2. Switch the player power ON, and play track 9 on the test disc (SZZP1056C). (Playing any other track will prevent, the HEX screws from being accessed.)
3. Alternately adjust the HEX screws with the 2.0mm allen wrench (SZZP1101C) until the vertical fluctuation of RF signal is minimized and the eye pattern is most stretched.
4. After completing the adjustment, lock the HEX screws with lock paint (RZZ0L01).

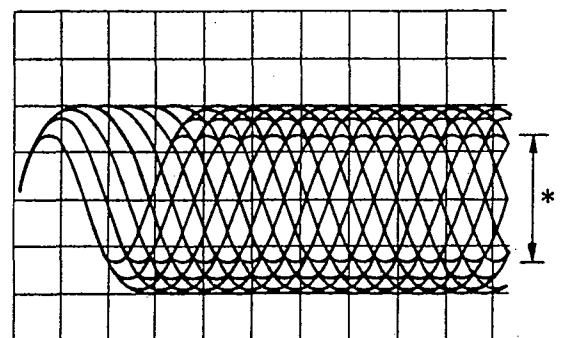

*Most stretched eye pattern.

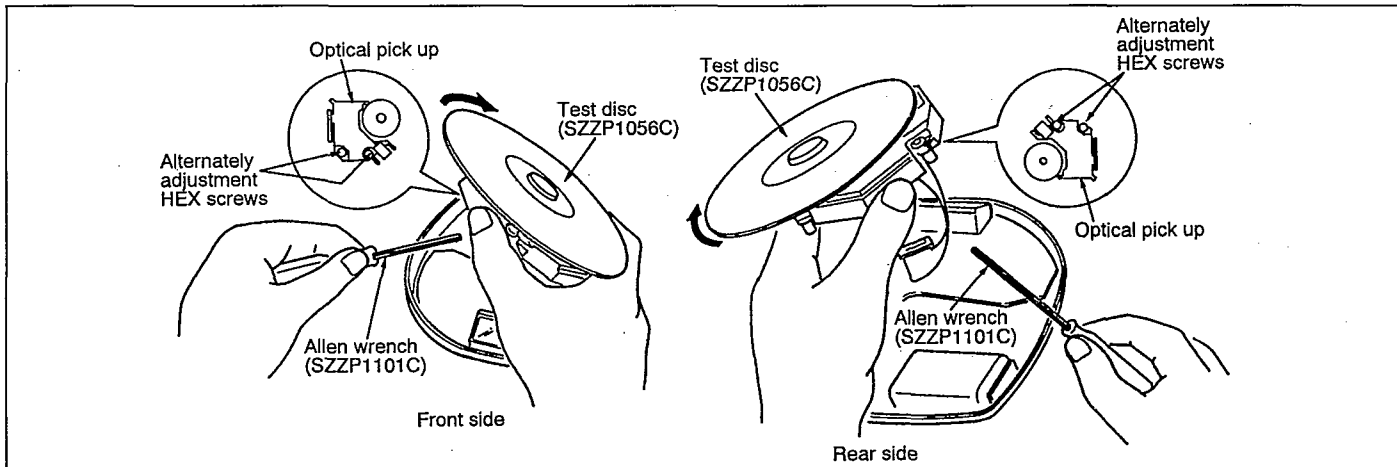

(2) CHECK OF PLAY OPERATION

*** Checking Skip Search**

1. Play an ordinary musical program disc.
2. Press the skip button to check for normal skip search operation (in both the forward and backward directions).

*** Checking Manual Search**

1. Play an ordinary musical program disc.
2. Press the manual search button to check for smooth manual search operations at either low or high speed (in both the forward and backward directions).

*** Checking Playability**

1. Play the 0.7mm black dot and the 0.7mm wedge on the playability test disc (SZZP1054C) and verify that no sound skip or noise occurs.
2. Play the middle tracks of the uneven test disc (SZZP1056C) and verify that no sound skip or noise occurs.

• Automatic adjustment

On our conventional type portable CD player, there were mounted 6 semi-fixed controls for each adjustment. Since the SL-XP160 servo circuit is equipped with an automatic adjusting circuit, these controls are removed from SL-XP160.

On conventional portable CD player
Use for Old Servo IC (AN8373SE2, AN8374SE2)

1. Tracking Offset Adjustment VR (TOC)
2. Focus Offset Adjustment VR (FOC)
3. Tracking Gain Adjustment VR (TGC)
4. Focus Gain Adjustment VR (FGC)
5. Tracking Balance Adjustment VR (TBC)
6. Focus Balance Adjustment VR (FBC)

On SL-XP160
Use for New Servo IC (AN8832SBE1, MN662740RE)

- Non Adjustment
- Automatic Adjusting Circuit

Total 6 Adjustment VRs → No Adjustment VR

Although all discs are manufactured according to the same specifications, their characteristics are not always precisely the same because they are produced by different manufacturers in various lots, or have different warp etc. SL-XP160 automatically controls the servo circuit to obtain optimum performance according to any disc's characteristics.

Therefore, no malfunction occurs because of mis-adjustment.

■ AUTOMATIC ADJUSTMENT RESULTS DISPLAY FUNCTION (SELF-CHECK FUNCTION)

On this unit (SL-XP160), each automatic adjustment result are displayed on the LCD. This function is convenient to check or identify which automatic adjustment circuit is incorrect. The followings are the contents of the automatic adjustment result displays (self-check function).

• How to display automatic adjustment results

1. Load the test disc (SZZP1054C).
2. Press the ◀◀ (SKIP/SEARCH) and ▶▶ (SKIP/SEARCH) Buttons simultaneously and hold them, and additionally press the ▶/|| (PLAY/PAUSE) Button.

3. Press the ■ (STOP/OPERATION OFF) Button once.
4. An automatic adjustment result is displayed on the LCD.

• Display of automatic adjustment results (self-check function)

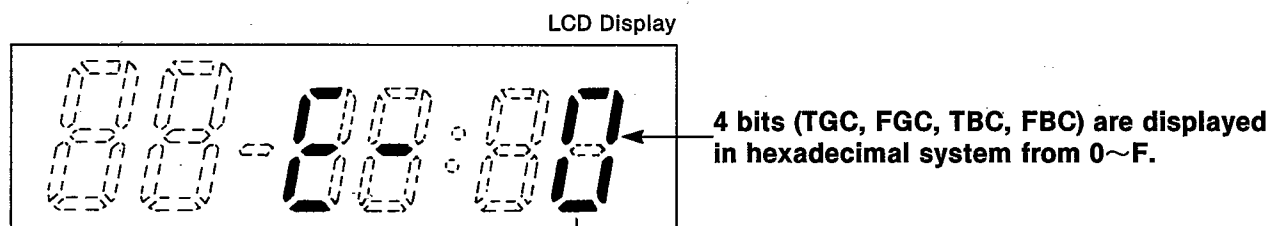

	MSB			LSB	
<Example>	TGC	FGC	TBC	FBC	(Each bit ... TGC, FGC, TBC, FBC)
	↓	↓	↓	↓	{ 0 ... OK 1 ... NG
1)	0	0	0	0	⇒ "E-0" is displayed.
	(All adjustments are OK.)..... Normal				
2)	0	0	0	1	⇒ "E-1" is displayed.
	(OK)	(OK)	(OK)	(NG)	
	(Focus balance adjustment is NG (incorrect.))				
3)	0	1	0	0	⇒ "E-4" is displayed.
	(OK)	(NG)	(OK)	(OK)	
	(Focus gain adjustment is NG.)				
4)	1	1	1	1	⇒ "E-F" is displayed.
	(All adjustments are NG.)				

<Example> Follow the below steps when "E-1" is displayed.

(Cause: Focus balance (FBC) is set beyond the limit.)

- Check if
 - (1) R101~104 (4 resistors) is not defective by measuring the value,
 - (2) the waveform or voltage of the focus servo circuit is correct, and
 - (3) the optical pickup returns to the normal state by exchanging the traverse deck.

Follow the below steps when "E-4" is displayed.

(Cause: Focus gain (FGC) is set beyond the limit.)

- Check if
 - (1) the waveform or voltage of the focus servo circuit is correct,
 - (2) the focus coil of the optical pickup is correct (around 8 ohms), and
 - (3) the optical pickup returns to the normal state by exchanging the traverse deck.

Follow the below steps when "E-F" is displayed.

(Cause: All adjustments (TGC, FGC, TBC, FBC) are set beyond the limit.)

- Check if
 - (1) the optical pickup returns to the normal state by exchanging the traverse deck, and
 - (2) the waveform or voltage of the servo IC's (IC101, 501) are correct.

Note:

It is not always necessary to exchange the traverse deck when an error message is displayed. Be sure to check if the circuit is defective or not before exchanging the traverse deck.

Note:

If any other disc than the test disc (SZZP1054C) is used, an error message may be displayed. This is not a malfunction.

BLOCK DIAGRAM

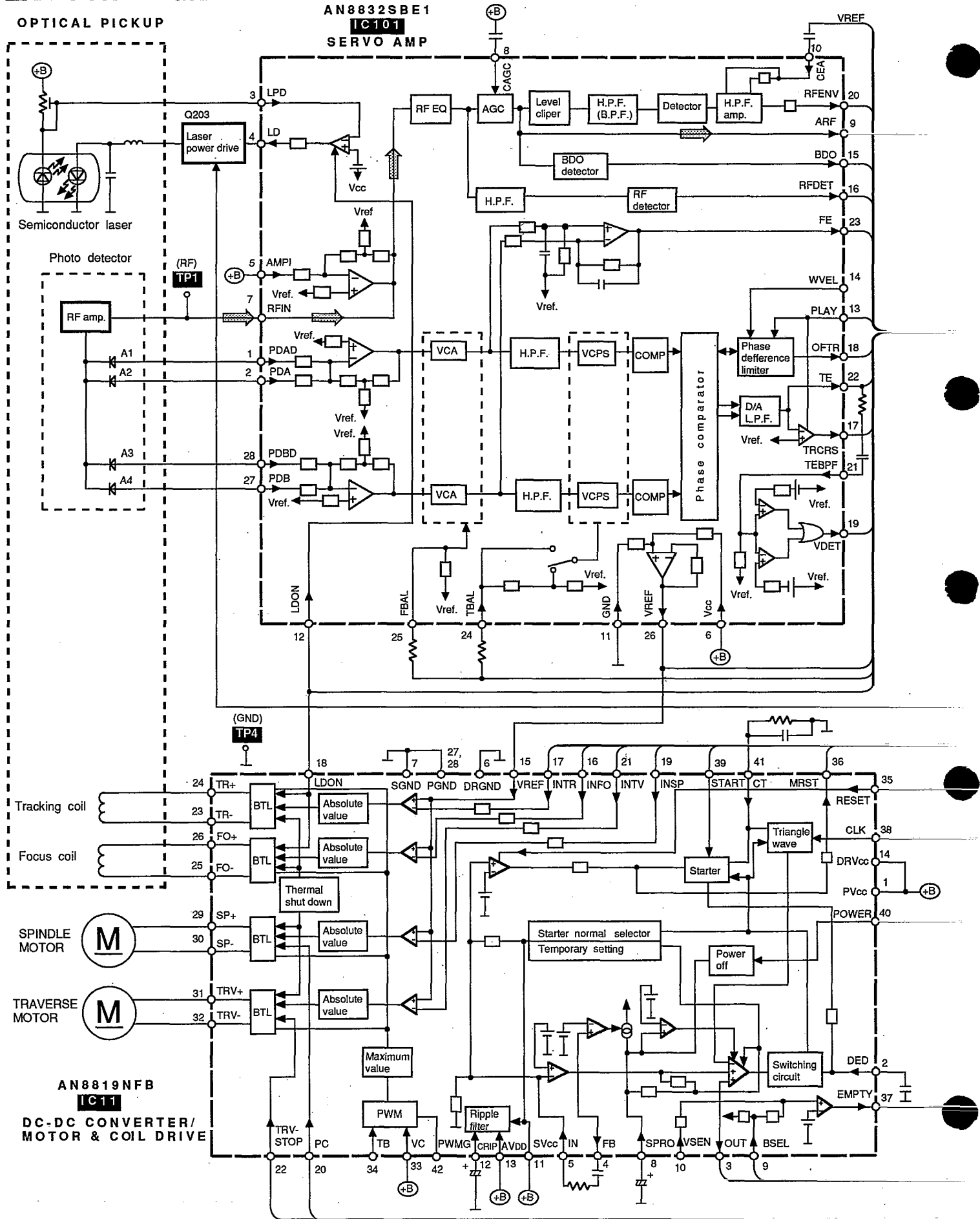

MN662740RE

IC501

SERVO PROCESSOR / DIGITAL SIGNAL PROCESSOR /
DIGITAL FILTER / D/A CONVERTER

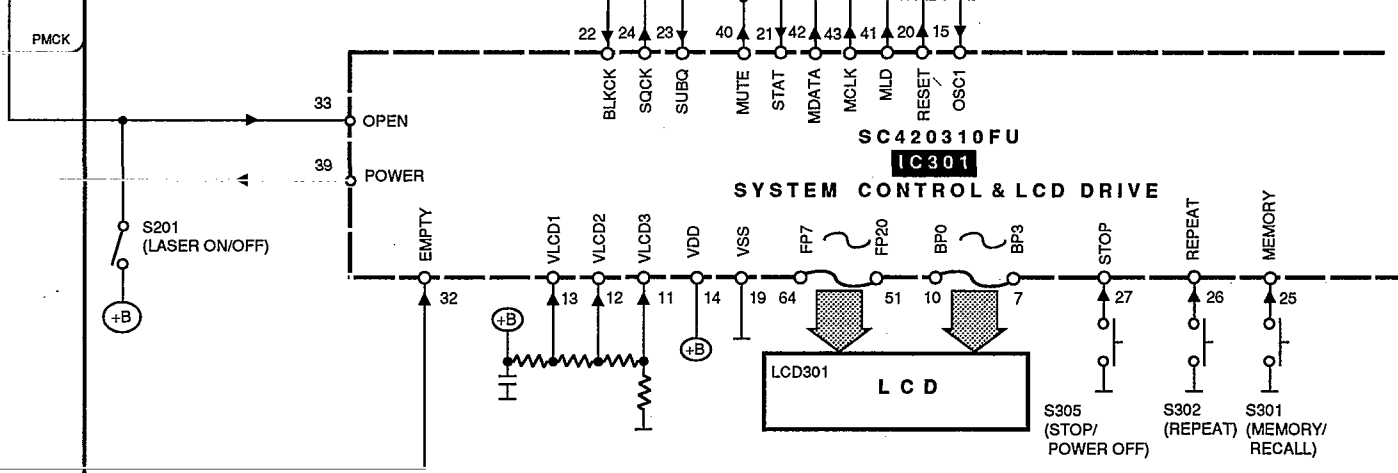
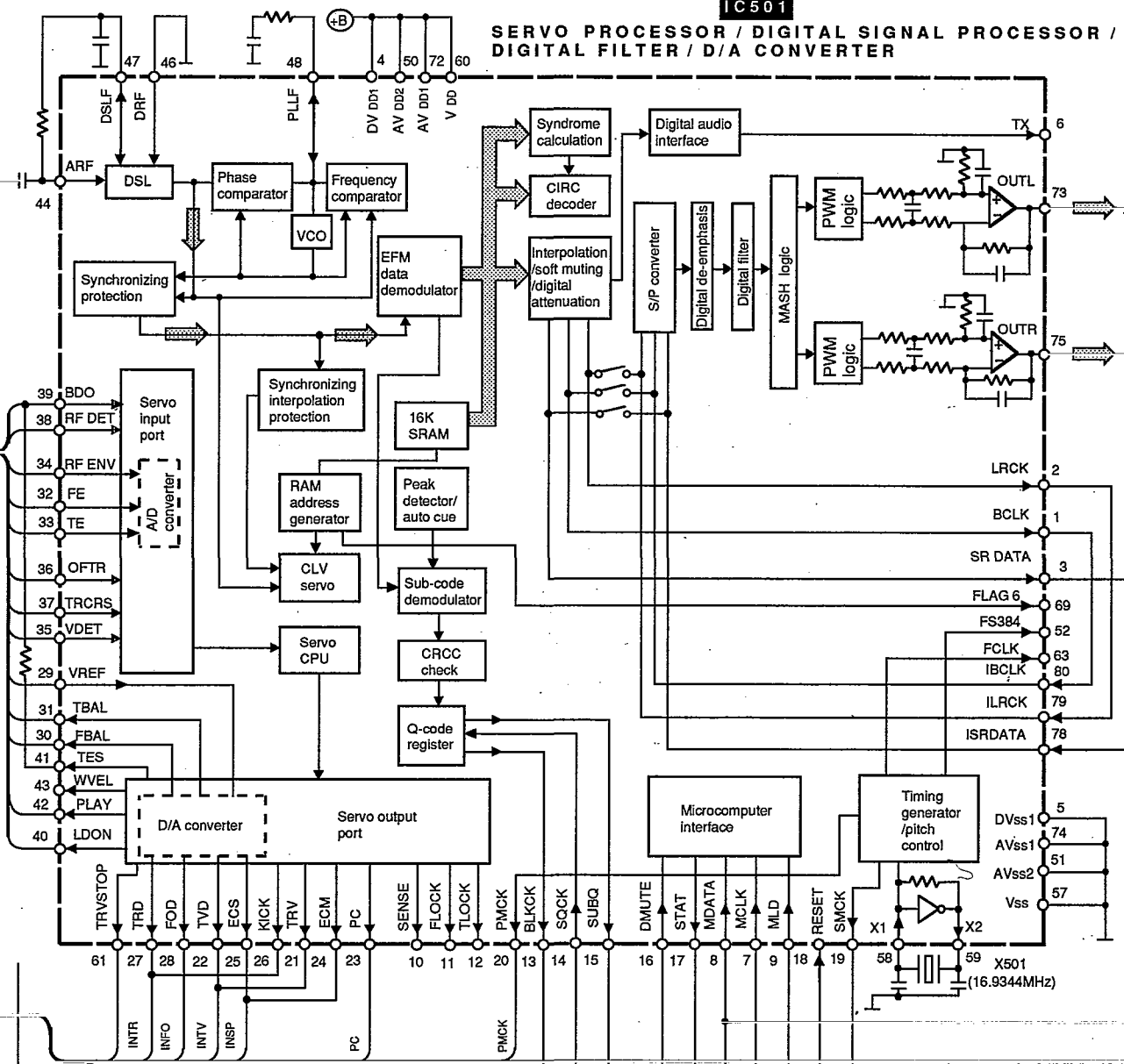

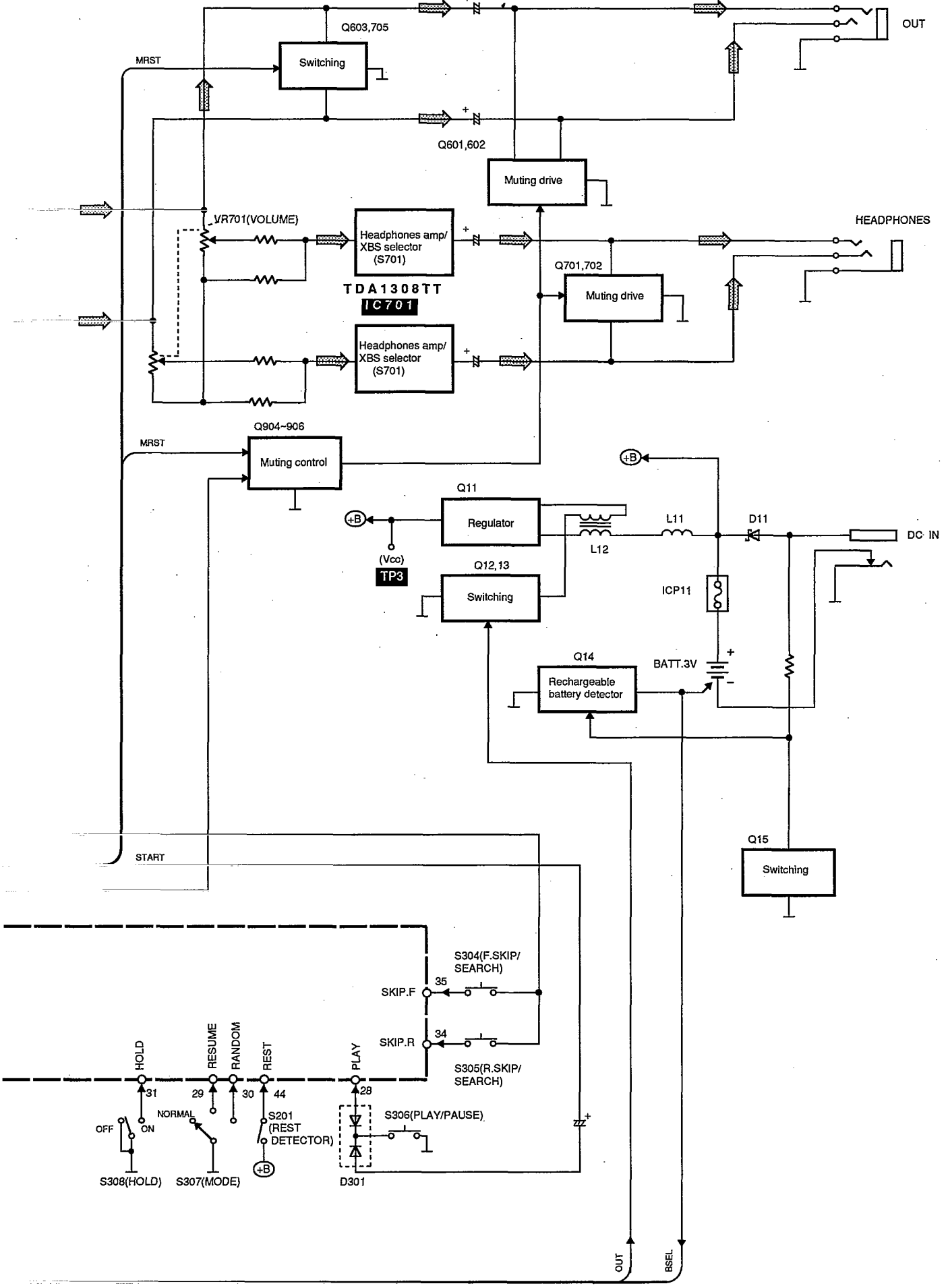

➡ : Audio signal lines.

■ SCHEMATIC DIAGRAM (Parts list on pages 29, 30)

(This schematic diagram may be modified at any time with the development of new technology.)

Notes:

- **S201** : Laser ON/OFF switch in "OFF" position.
(It turns "ON" with disc holder closed.)
- **S202** : Rest detector in "OFF" position.
(It turns "ON" when optical pickup comes to innermost periphery.)
- **S301** : Memory/recall (MEMORY/RECALL) switch.
- **S302** : Repeat (REPEAT) switch.
- **S303**, **S304** : Skip/search (◀◀-SKIP/-SEARCH ▶▶) switches.
S303: ▶▶, S304: ◀◀
- **S305** : Stop/operation off (■ OPR OFF) switch.
- **S306** : Play/pause (▶ ■) switch.
- **S307** : Play mode selector (MODE) in "NORMAL" position.
- **S308** : Hold (HOLD) switch in "OFF" position.
- **S701** : XBS selector (XBS OFF) in "OFF" position.
- The voltage value and waveforms are the reference voltage of this measured by DC electronic voltmeter (high impedance) and oscilloscope on the basis of GND terminal (DC IN Jack).
Accordingly, there may arise some errors in the voltage values and waveforms depending upon the internal impedance of the tester or measuring unit.

- * The parenthesized is the voltage for test disc (1 kHz, L+R, 0dB) in play mode, and the other, for no disc in stop mode.
- * AC adaptor is used for power supply.

-  : Positive voltage lines.
-  : Audio signal lines.

- Important safety notice:
Components identified by Δ mark have special characteristics important for safety. Furthermore, special parts which have purposes of fire-retardant (resistors), high-quality sound (capacitors), low-noise (resistors), etc. are used. When replacing any of components, be sure to use only manufacture's specified parts shown in the parts list. \ast marks indicate printed resistor.

Caution!

IC and LSI are sensitive to static electricity. Secondary trouble can be prevented by taking care during repair.

- Cover the parts boxes made of plastics with aluminium foil.
- Ground the soldering iron.
- Put a conductive mat on the work table.
- Do not touch the pins of IC or LSI with fingers directly.

● Terminal guide of IC's, transistors and diodes

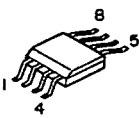
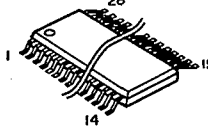
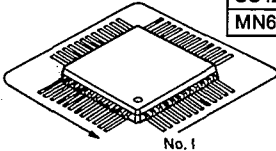
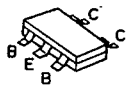
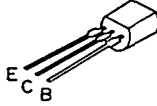
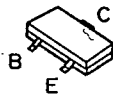
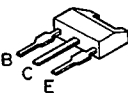
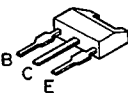
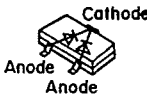
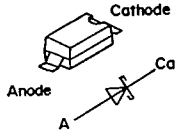
<p>TDA1308TT</p> 	<p>AN8832SBE1</p> 	<table border="1" data-bbox="802 1055 1018 1133"> <tr> <td>AN8819NFB</td> <td>44 Pin</td> </tr> <tr> <td>SC420310FU</td> <td>64 Pin</td> </tr> <tr> <td>MN662740RE</td> <td>80 Pin</td> </tr> </table> 	AN8819NFB	44 Pin	SC420310FU	64 Pin	MN662740RE	80 Pin	<p>FMG4T148</p> 	<p>2SD1302STTA</p> 
AN8819NFB	44 Pin									
SC420310FU	64 Pin									
MN662740RE	80 Pin									
	<p>2SB709QRSTX 2SD601QRSTX 2SD1328RSTTX UN221VTX UN2114TX</p> 	<p>2SD2074HWRST 2SD2074HWSTT</p> 	<p>MA151WKTX</p> 	<p>MBR5130LT3</p> 						

(P.C. Board : on pages 23, 24)

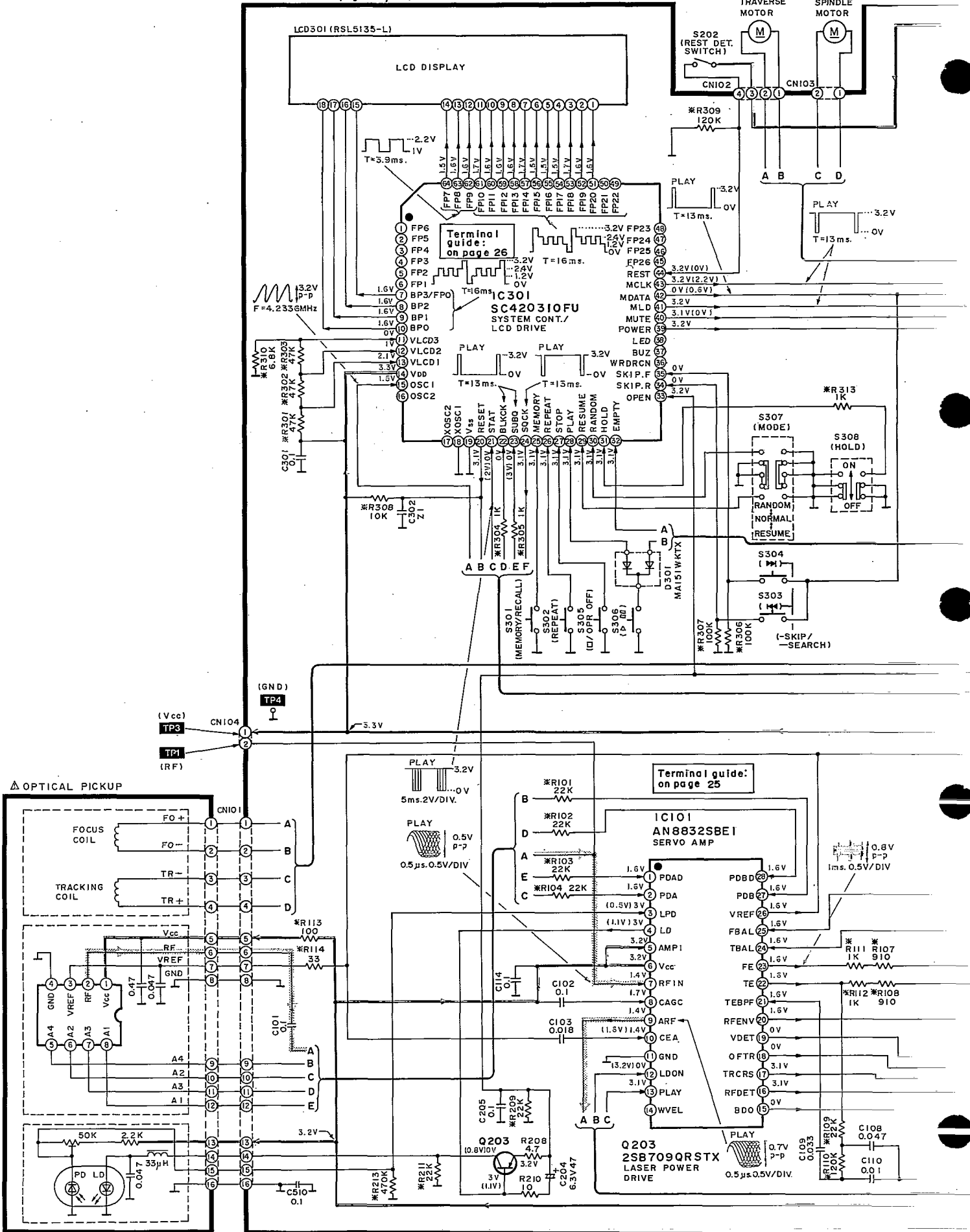

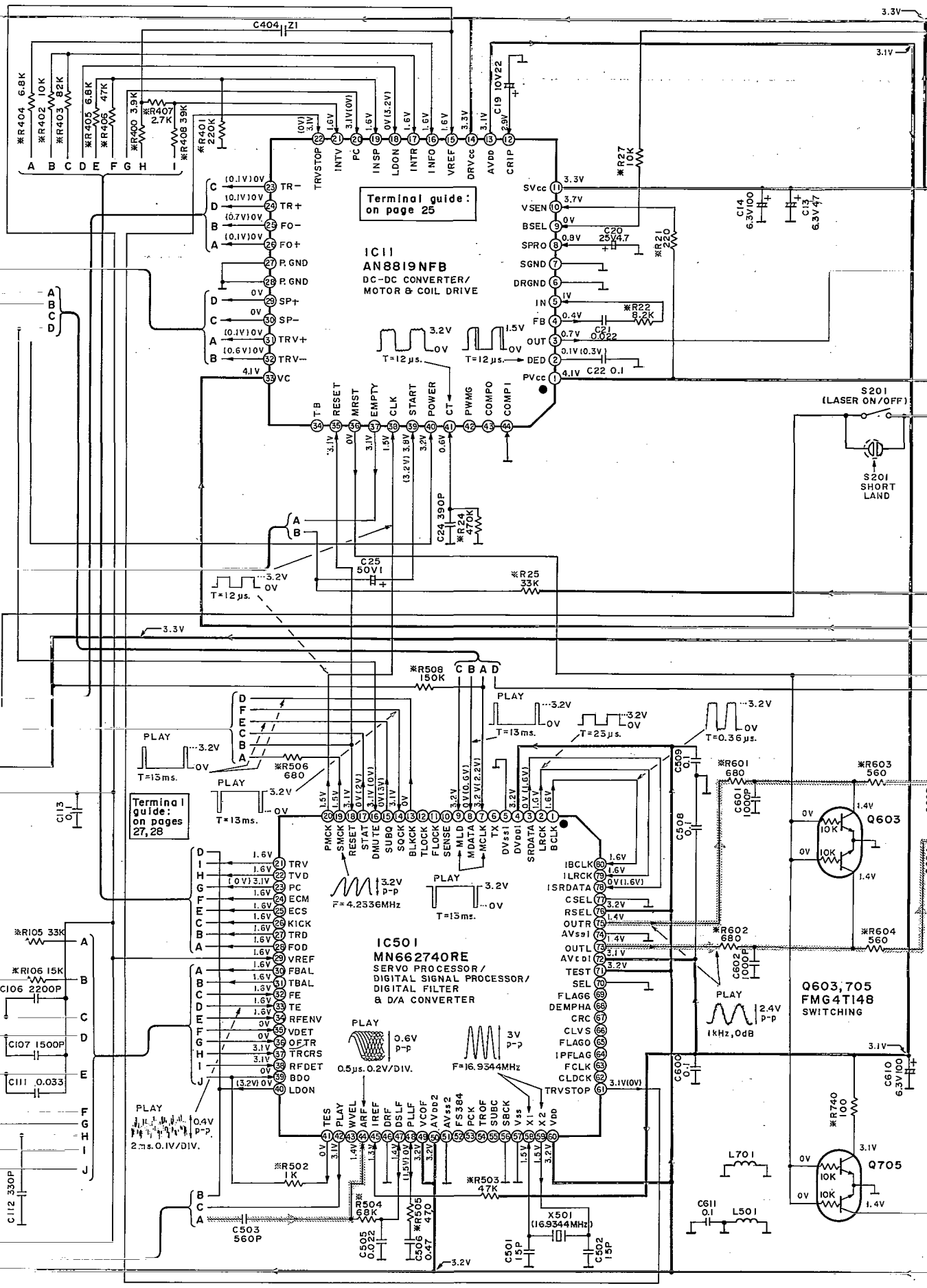

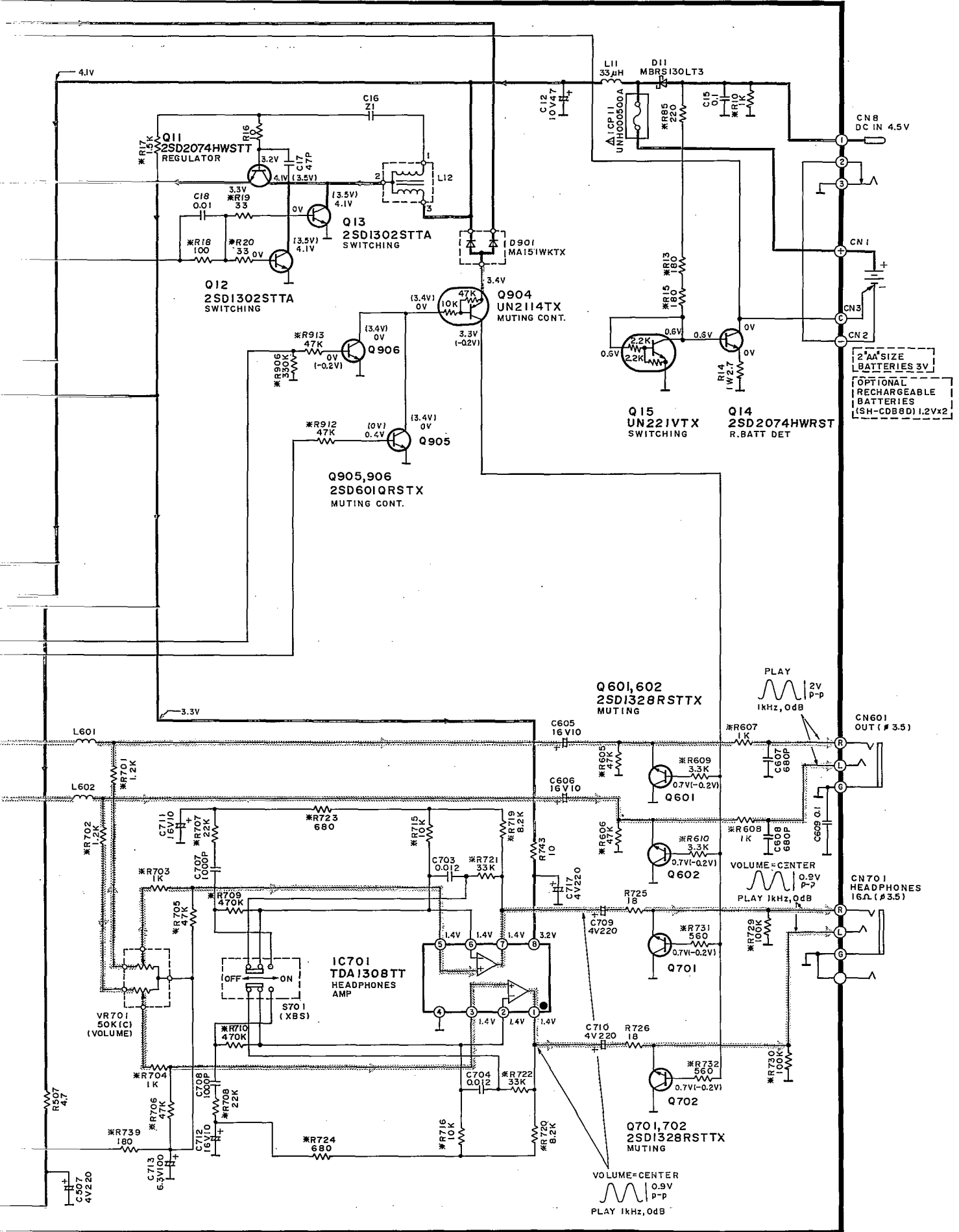

PRINTED CIRCUIT BOARD AND WIRING CONNECTION DIAGRAM

Notes:

- In this printed circuit board diagram, the parts and foil patterns on the board facing toward you are printed in black. The opposite side is printed in blue.
- The "●" mark denotes the connection points of double-faced foil patterns (through holes) on both sides of the printed circuit board.
- This printed circuit board diagram may be modified at any time with the development of new technology.

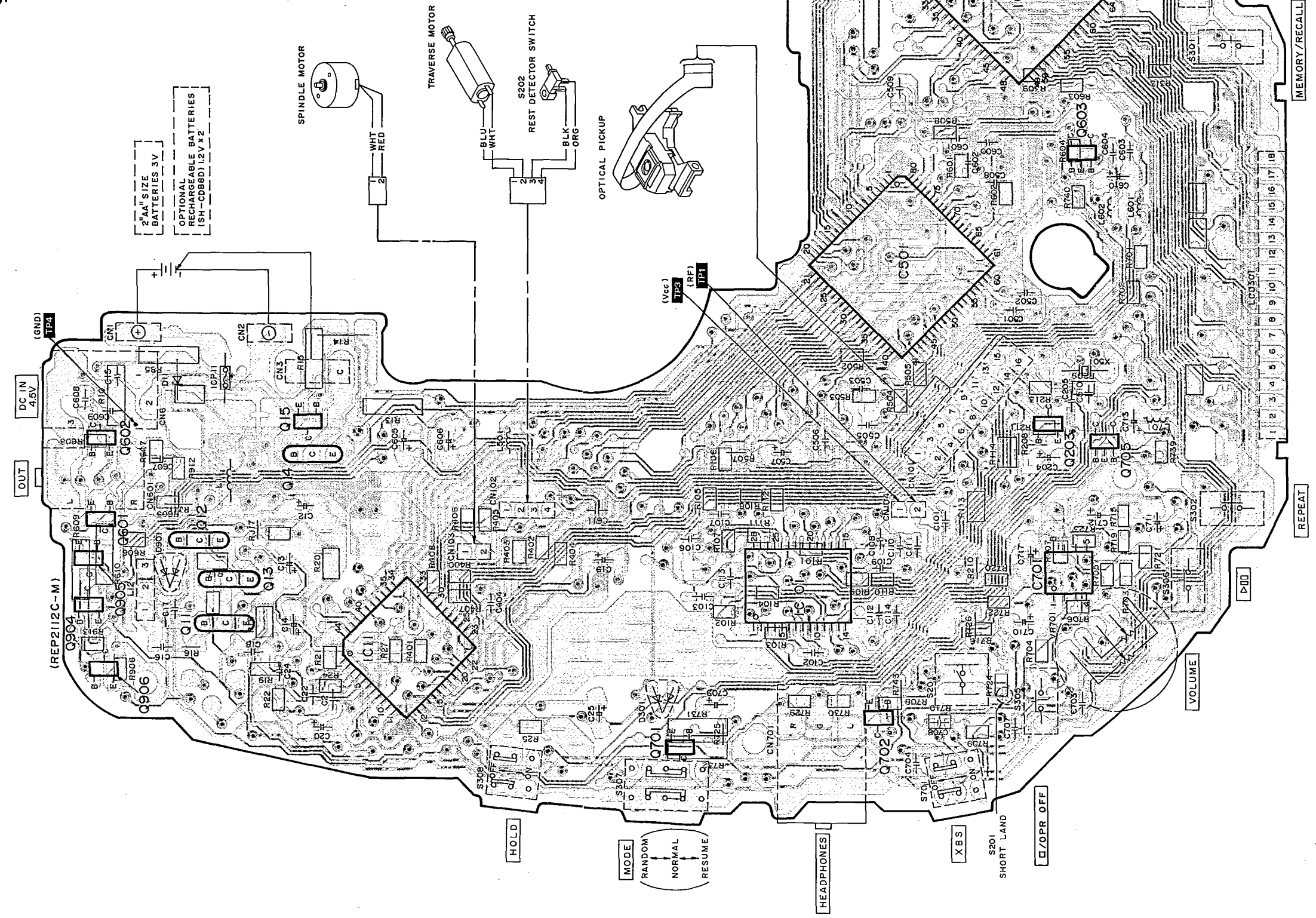

TERMINAL GUIDE

• IC11 (AN8819NFB): DC-DC converter/motor & coil drive

Pin No.	Mark	I/O Division	Function
1	PV _{CC}	I	Power supply terminal
2	DED	I	Dead time input
3	OUT	O	Switching output
4	FB	O	Error amp output
5	IN	I	Error amp input
6	DRGND	—	Ground terminal
7	SGND	—	Ground terminal
8	SPRO	I	Short protect circuit
9	BSEL	I	Battery select terminal
10	VSEN	I	Empty detect terminal
11	SV _{CC}	I	Power supply terminal
12	CRIP	I	Ripple filter terminal
13	AV _{DD}	O	Power supply terminal
14	DRV _{CC}	I	Power supply terminal
15	VREF	I	Reference voltage input
16	INFO	I	Focus coil control signal input
17	INTR	I	Tracking coil control signal input
18	LDON	I	Laser ON/OFF control signal input
19	INSP	I	Spindle motor control signal input
20	PC	I	Phase control terminal
21	INTV	I	Traverse motor control signal input
22	TRVSTOP	I	Traverse motor stopping signal input

Pin No.	Mark	I/O Division	Function
23	TR-	O	Tracking coil drive signal output
24	TR+		
25	FO-	O	Focus coil drive signal output
26	FO+		
27	P. GND	—	Ground terminal
28	P. GND	—	Ground terminal
29	SP+	O	Spindle motor drive signal output
30	SP-		
31	TRV+	O	Traverse motor drive signal output
32	TRV-		
33	VC	I	PWM control terminal
34	TB	I	PWM control terminal
35	RESET	O	Reset signal output
36	MRST	O	Muting signal output
37	EMPTY	O	Empty signal output
38	CLK	I	Clock signal input (f=88.2kHz)
39	START	I	Start detection input
40	POWER	I	Power ON/OFF detection terminal
41	CT	I	Triangular wave oscillator capacitor input
42	PWMG	—	Not used, open
43	COMPO	—	Not used, open
44	COMPI	I	Ground terminal

• IC101 (AN8832SBE1): Servo amp.

Pin No.	Mark	I/O Division	Function
1	PDAD	I	Photo detector current input
2	PDA	I	Photo detector current input
3	LPD	I	Non-inverting laser power input
4	LD	O	Laser power auto control output
5	AMPI	I	RF signal input Not used, connected to V _{CC}
6	V _{CC}	I	Power supply terminal
7	RFIN	I	RF signal input
8	CAGC	I	AGC detecting capacitor terminal
9	ARF	O	RF signal output
10	CEA	O	HPF-amp. terminal
11	GND	—	Ground terminal
12	LDON	I	Laser ON/OFF control input
13	PLAY	I	Play control terminal
14	WVEL	—	WVEL control terminal Not used open

Pin No.	Mark	I/O Division	Function
15	BDO	O	Dropout detection output
16	RFDET	O	NRFDET signal output
17	TRCRS	O	CROSS signal output
18	OFTR	O	OFTR signal output
19	VDET	O	VDET signal output
20	RFENV	O	Envelope signal output
21	TEBPF	I	Shock detection signal input
22	TE	O	Tracking error signal output
23	FE	O	Focus error signal output
24	TBAL	I	Tracking balance signal input
25	FBAL	I	Focus balance signal input
26	VREF	O	Reference voltage output
27	PDB	I	Photo detector current input
28	PDBD	I	Photo detector current input

• IC301 (SC420310FU): System control/LCD drive

Pin No.	Mark	I/O Division	Function
1 6	FP6 FP1	—	LCD segment signal output Not used, open
7	BP3/FP0	O	LCD segment signal output
8 10	BP2 BP0	O	LCD segment signal output
11	VLCD3	I	Voltage control terminal
12	VLCD2		
13	VLCD1		
14	V _{DD}	I	Power supply terminal
15	OSC1	I	Main-system clock input terminal
16	OSC2	—	Not used, open
17	XOSC2	—	Not used, open
18	XOSC1	—	Not used, connected to GND
19	V _{SS}	—	Ground terminal
20	RESET	O	Reset signal output terminal
21	STAT	I	Processing condition (CRU, CUE, CLVS, FCLV, TTSTOP) input
22	BLKCK	I	Sub-code block (Q data) clock (75Hz) output
23	SUBQ	I	Sub-code (Q data) output
24	SQCK	O	Sub-code Q resistor clock output
25	MEMORY	I	Key Input terminal (MEMORY)
26	REPEAT	I	Key Input terminal (REPEAT)
27	STOP	I	Key Input terminal (STOP)

Pin No.	Mark	I/O Division	Function
28	PLAY	I	Key input terminal (PLAY/PAUSE)
29	RESUME	I	Key input terminal (RESUME)
30	RANDOM	I	Key input terminal (RANDOM)
31	HOLD	I	Key Input terminal (HOLD)
32	EMPTY	I	Empty detect signal input
33	OPEN	I	Disc holder open detect terminal
34	SKIP. R	I	Key input terminal (SKIP/SEARCH. R.)
35	SKIP. F	I	Key input terminal (SKIP/SEARCH. F.)
36	WRDRCN	—	Remote control signal output Not used, open
37	BUZ	—	Beep control output Not used, open
38	LED	—	LED drive command signal Not used, open
39	POWER	O	Power ON/OFF signal output
40	MUTE	O	Muting signal output ("H": MUTE)
41	MLD	O	Command load signal output
42	MDATA	O	Command data output
43	MCLK	O	Command clock output
44	REST	I	Rest detect terminal
45 50	FP26 FP21	—	LCD segment signal output Not used, open
51 64	FP20 FP7	O	LCD segment signal output

• IC501 (MN662740RE): Servo processor/Digital signal processor/Digital filter/D/A converter

Pin No.	Mark	I/O Division	Function
1	BCLK	O	Serial bit clock output
2	LRCK	O	L/R discriminating signal output
3	SRDATA	O	Serial data signal output
4	DV _{DD1}	I	Power supply (digital circuit) terminal
5	DV _{SS1}	—	GND (digital circuit) terminal
6	TX	—	Digital audio interface signal (Not used, open)
7	MCLK	I	Command clock signal
8	MDATA	I	Command data signal
9	MLD	I	Command load signal ("L": LOAD)
10	SENSE	—	Sense signal (OFT, FESL, NACEND, NAJEND, POSAD, SFG) (Not used, open)
11	FLOCK	—	Optical servo condition (focus) ("L": lead-in) (Not used, open)
12	TLOCK	—	Optical servo condition (tracking) ("L": lead-in) (Not used, open)
13	BLKCK	O	Sub-code block clock (f=75Hz)
14	SQCK	I	Sub-code Q register clock
15	SUBQ	O	Sub-code Q data
16	DMUTE	I	Muting input ("H": MUTE) (Not used, connected to GND)
17	STAT	O	Status signal (CRC, CUE, CLVS, TTSTOP, FCLV, SQCK)
18	RESET	I	Reset signal ("L": reset)
19	SMCK	O	System clock (f=4.2336MHz)
20	PMCK	O	Frequency division clock signal ($f = \frac{1}{1.92} \times ck = 88.2\text{kHz}$)
21	TRV	O	Traverse servo control

Pin No.	Mark	I/O Division	Function
22	TVD	O	Traverse drive signal
23	PC	O	Turntable motor drive signal ("L": ON)
24	ECM	O	Turntable motor drive signal (Forced mode)
25	ECS	O	Turntable motor drive signal (Servo error signal)
26	KICK	O	Kick pulse output
27	TRD	O	Tracking drive signal output
28	FOD	O	Focus drive signal output
29	VREF	I	D/A drive output (TVD, ECS, TRD, FOD, FBAL, TBAL) normal voltage input terminal
30	FBAL	O	Focus balance adj. output (Not used, open)
31	TBAL	O	Tracking balance adj. output
32	FE	I	Focus error signal (analog input)
33	TE	I	Tracking error signal (analog input)
34	RFENV	I	RF envelope signal
35	VDET	I	Oscillation det. signal ("H": det.)
36	OFTR	I	Off track signal ("H": Off track)
37	TRCRS	I	Track cross signal input
38	RFDET	I	RF detection signal ("L": detection)
39	BDO	I	Dropout detection signal ("H": dropout)
40	LDON	O	Laser power control ("H": ON)
41	TES	O	Tracking error shunt output ("H": dropout)
42	PLAY	O	Play signal ("H": play)

Pin No.	Mark	I/O Division	Function
43	WVEL	—	Double velocity status signal ("H": double) (Not used, open)
44	ARF	I	RF signal input
45	IREF	I	Reference current input
46	DRF	I	DSL bias terminal (Not used, connected to GND)
47	DSL F	I/O	DSL loop filter terminal
48	PLLF	I/O	PLL loop filter terminal
49	VCOF	I	VCO loop filter terminal (Not used, connected to AV _{DD2})
50	AV _{DD2}	I	Power supply (analog circuit) terminal (2)
51	AV _{SS2}	—	GND (analog circuit) terminal
52	FS384	—	384 fs (16.9344MHz) output (Not used, open)
53	PCK	—	PLL extract clock (f=4.3218MHz) (Not used, open)
54	TROF	—	Tracking servo OFF signal (Not used, open)
55	SUBC	—	Sub-code serial output data (Not used, open)
56	SBCK	—	Sub-code serial input clock (Not used, connected to GND)
57	V _{SS}	—	GND terminal
58	X1	I	Crystal oscillator terminal (f=16.9344MHz)
59	X2	O	
60	V _{DD}	I	Power supply terminal
61	TRVSTOP	O	Traverse motor stop control terminal
62	CLDCK	—	Sub-code frame clock signal (f CLDCK=7.35kHz: Normal) (Not used, open)

Pin No.	Mark	I/O Division	Function
63	FCLK	—	Crystal frame clock (Not used, open)
64	IPFLAG	O	Interpolation flag terminal
65	FLAGO	O	Flag terminal
66	CLVS	—	Turntable servo phase synchro signal ("H": CLV, "L": Rough servo) (Not used, open)
67	CRC	—	Sub-code CRC check terminal ("H": OK, "L": NG) (Not used, open)
68	DEMPHA	—	De-emphasis ON signal ("H": ON) (Not used, open)
69	FLAG6	O	Flag terminal
70	SEL	I	Not used, connected to GND
71	TEST	I	Test terminal (Normal: "H")
72	AV _{DD1}	I	Power supply (analog circuit) terminal (1)
73	OUTL	O	Lch audio signal
74	AV _{SS1}	—	GND (analog circuit) terminal (1)
75	OUTR	O	Rch audio signal
76	RSEL	I	Polarity direction control terminal of RF signal (Not used, connected to power supply)
77	CSEL	I	Frequency control terminal of crystal oscillator (Not used, connected to GND)
78	ISRDATA	I	Serial data signal input
79	ILRCK	I	L/R discriminating signal input
80	IBCLK	I	Serial bit clock input

REPLACEMENT PARTS LIST

Notes: *Important safety notice:

 Components identified by Δ mark have special characteristics important for safety.

Furthermore, special parts which have purposes of fire-retardant (resistors), high-quality sound (capacitors), low-noise (resistors), etc. are used. When replacing any of components, be sure to use only manufacturer's specified parts shown in the parts list.

*The parenthesized indications in the Remarks columns specify the areas. (Refer to the cover page for area.)

Parts without these indications can be used for all areas.

*Warning: This product uses a laser diode. Refer to caution statements on page 2.

*ACHTUNG: Die Lasereinheit nicht zerlegen.

Die Lasereinheit darf nur gegen eine vom Hersteller spezifizierte Einheit ausgetauscht werden.

Ref. No.	Part No.	Part Name & Description	Remarks	Ref. No.	Part No.	Part Name & Description	Remarks
						OSCILLATOR(S)	
		INTEGRATED CIRCUIT(S)					
IC11	AN8819NFB	DC-DC CONV.		X501	RSXZ16M9M01T	OSCILLATOR (16.9344MHz)	
IC101	AN8832SBE1	SERVO AMP				LCD(S)	
IC301	SC420310FU	SYSTEM CONT. & LCD DRIVE		LCD301	RSL5135-L	LCD	
IC501	MN662740RE	SERVO PROCESSOR				SWITCH(ES)	
IC701	TDA1308TT	HEADPHONES AMP		S201	ESH1A91ZA-A	OPEN/CLOSE	
		TRANSISTOR(S)		S202	SSHD5	REST DETECTOR	
Q11	2SD2074HWSTT	TRANSISTOR		S301	EVQ21405R	MEMORY/RECALL	
Q12, 13	2SD1302STTA	TRANSISTOR		S302	EVQ21405R	REPEAT	
Q14	2SD2074HWRST	TRANSISTOR		S303	EVQ21405R	SKIP. R	
Q15	UN221VTX	TRANSISTOR		S304	EVQ21405R	SKIP. F	
Q203	2SB709QRSTX	TRANSISTOR		S305	EVQ21405R	STOP/OPR OFF	
Q601, 602	2SD1328QRSTX	TRANSISTOR		S306	EVQ21405R	PLAY/PAUSE	
Q603	FMG4T148	TRANSISTOR		S307	ESD11H230	PLAY MODE	
Q701, 702	2SD1328QRSTX	TRANSISTOR		S308	ESD11H220	HOLD	
Q705	FMG4T148	TRANSISTOR		S701	ESD11H220	XBS	
Q904	UN2114TX	TRANSISTOR				CONNECTOR(S) AND JACK(S)	
Q905, 906	2SD601QRSTX	TRANSISTOR		CN1	RJC93015-1	BATTERY TERMINAL(+)	
		DIODE(S)		CN2	RJC93015-1	BATTERY TERMINAL(-)	
D11	MBRS130LT3	DIODE		CN3	RJH5102-1	RECHARGEABLE BATT. TERMINAL	
D301	MA151WKTX	DIODE		CN8	RJJ4303-1	DC IN JACK	
D901	MA151WKTX	DIODE		CN101	RJU035T016-1	SOCKET(16P)	
		IC PROTECTOR(S)		CN102	RJT068W04V	CONNECTOR(4P)	
ICP11	UNH00500A	IC PROTECTOR	Δ	CN103, 104	RJT068W02V	CONNECTOR(2P)	
		VARIABLE RESISTOR(S)		CN601	RJJD3S5ZB-C	OUT JACK	
VR701	EVUT2FA26C54	VOLUME		CN701	RJJ34TH02-C	HEADPHONES JACK	
		COIL(S)					
L11	RLQB330KT-M	COIL					
L12	RLZ0028T-0	COIL					
L501	RLB0003	COIL					
L601, 602	RLB0003	COIL					
L701	RLB0003	COIL					

Ref. No.	Part No.	Part Name & Description	Remarks	Ref. No.	Part No.	Part Name & Description	Remarks
		CABINET AND CHASSIS		8	RYF0335A-K	CD COVER ASS'Y	
				9	RFKJLXP160EK	INTERMEDIATE CABINET ASS'Y	
				10	RGU1030-H	OPEN BUTTON	
1	RKK0065-K	BATTERY COVER		11	RGU1031-H2	P. /PAUSE, STOP, REPEAT BUTTON	
2	RJF0023	LCD HOLDER		12	RGU1032-H2	M./REC., SKIP/SEARCH BUTTON	
3	RGV0120-1K	XBS/HOLD/P. MODE KNOB		13	RHE5079YA	SCREW	
4	RJC93007	COMMON BATTERY TERMINAL		14	RMB0351	OPEN SPRING	
5	RFKJLXP160E	BOTTOM CABINET ASS'Y	(E)	15	RML0342	LOCK LEVER	
5	RFKJLXP160EB	BOTTOM CABINET ASS'Y	(EB, GC, GN)	16	RMS0462	PUSH SHAFT	
5	RFKJLXP160EG	BOTTOM CABINET ASS'Y	(EG)	17	XTN17+6GFZ	SCREW	
5-1	RKA0063-K	FOOT		18	RAE0133Z	TRAVERSE DECK	
6	RMA0677	REAR ORNAMENT		18-1	SHGD157	FLOATING RUBBER(1)	
7	RMS0105-1	SHAFT		18-2	SHGD165	FLOATING RUBBER(2)	

RESISTORS AND CAPACITORS

Notes : * Capacity values are in microfarads (μF) unless specified otherwise, P=Pico-farads (pF) F=Farads (F)
 * Resistance values are in ohms, unless specified otherwise, 1K=1,000 (OHM), 1M=1,000k (OHM)

Ref. No.	Part No.	Values & Remarks	Ref. No.	Part No.	Values & Remarks	Ref. No.	Part No.	Values & Remarks
		RESISTORS	C16	ECUVNC105ZFN	16V 1U	C404	ECUVNC105ZFN	16V 1U
			C17	ECUV1H470KCN	50V 47P	C501, 502	ECUV1H150KCN	50V 15P
			C18	ECUV1E103KBN	25V 0.01U	C503	ECUV1H561KBN	50V 560P
R14	ERJ1WYK2R7H	1W 2.7	C19	ECEA1AKA220I	10V 22U	C505	ECUV1E223KBN	25V 0.022U
R16	ERJ6GEYJ100	1/10W 10	C20	ECEA1EKA4R7I	25V 4.7U	C506	ECUV1C474KBM	16V 0.47U
R208	ERJ6GEYK4R7V	1/10W 4.7	C21	ECUV1E223KBN	25V 0.022U	C507	ECEA0GKA221	4V 220U
R210	ERJ6GEYJ100	1/10W 10	C22	ECUV1C104KBN	16V 0.1U	C508-510	ECUV1C104ZFN	16V 0.1U
R507	ERJ6GEYK4R7V	1/10W 4.7	C24	ECUV1H391KBN	50V 390P	C600	ECUV1C104ZFN	16V 0.1U
R725	ERJ6GEYJ180V	1/10W 18	C25	ECEA1HKA010I	50V 1U	C601, 602	ECUV1H102KBN	50V 1000P
R726	ERJ8GEYJ180V	1/8W 18	C101, 102	ECUV1C104KBN	16V 0.1U	C603, 604	ECUV1H272KBN	50V 2700P
R743	ERJ6GEYJ100	1/10W 10	C103	ECUV1E183KBN	25V 0.018U	C605, 606	ECEA1CKA100I	16V 10U
		CHIP JUMPERS	C106	ECUV1H222KBN	50V 2200P	C607, 608	ECUV1H681KBN	50V 680P
			C107	ECUV1H152KBN	50V 1500P	C609	ECUV1C104ZFN	16V 0.1U
			C108	ECUV1C473KBN	16V 0.047U	C610	RCE0JKA1011V	6.3V 100U
RJ11	ERJ8GEYOR00V	CHIP JUMPER	C109	ECUV1C333KBN	16V 0.033U	C611	ECUV1C104ZFN	16V 0.1U
RJ17	ERJ6GEYOR00V	CHIP JUMPER	C110	ECUV1E103KBN	25V 0.01U	C703, 704	ECUV1E123KBN	25V 0.012U
		CAPACITORS	C111	ECUV1C333KBN	16V 0.033U	C707, 708	ECUV1H102KBN	50V 1000P
			C112	ECUV1H331KBN	50V 330P	C709, 710	ECEA0GKA221	4V 220U
			C113, 114	ECUV1C104ZFN	16V 0.1U	C711, 712	ECEA1CKA100I	16V 10U
C12	RCE1AKA4701G	10V 47U	C204	RCE0JKA4701G	6.3V 47U	C713	RCE0JKA1011V	6.3V 100U
C13	RCE0JSC4701X	6.3V 47U	C205	ECUV1C104ZFN	16V 0.1U	C717	ECEA0GKA221	4V 220U
C14	RCE0JKA1011V	6.3V 100U	C301	ECUV1C104ZFN	16V 0.1U			
C15	ECUV1C104ZFN	16V 0.1U	C302	ECUVNC105ZFN	16V 1U			

1 2 3 4 5

■ CABINET PARTS LOCATION

The parts enclosed in the dotted boxes are supplied as a block assembly. Therefore, they are not supplied separately except parts indicated with Ref. No.

A
B
C
D
E
F
G

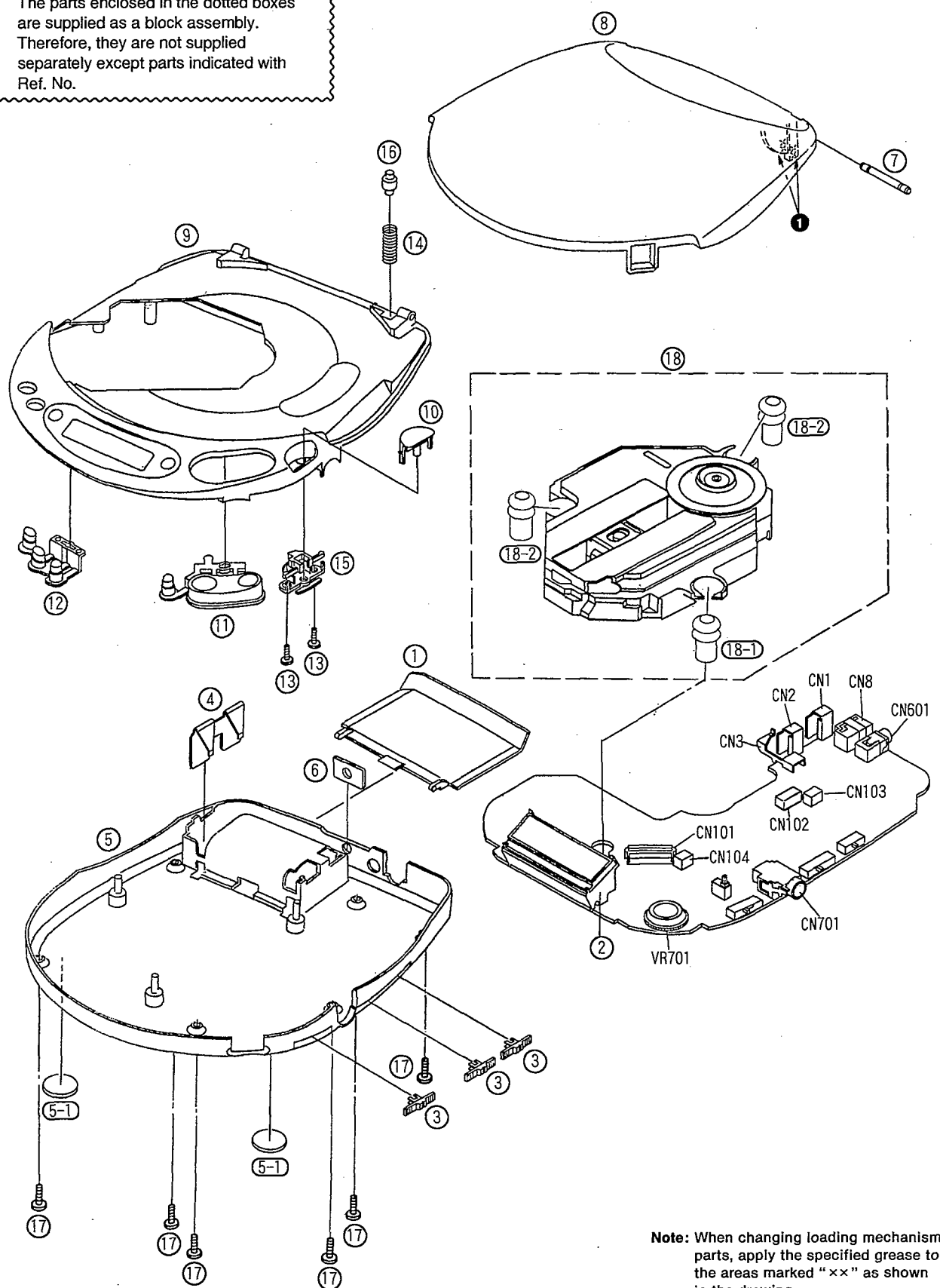

Note: When changing loading mechanism parts, apply the specified grease to the areas marked "x" as shown in the drawing.

Ref. No.	Part No.
①	RFKXPG671

REPLACEMENT PARTS LIST

Notes: *Important safety notice:
 Components identified by Δ mark have special characteristics important for safety.
 Furthermore, special parts which have purposes of fire-retardant (resistors), high-quality sound (capacitors), low-noise (resistors), etc. are used.
 When replacing any of components, be sure to use only manufacturer's specified parts shown in the parts list.
 *The parenthesized indications in the Remarks columns specify the areas. (Refer to the cover page for area.)
 Parts without these indications can be used for all areas.
 *Warning: This product uses a laser diode. Refer to caution statements on page 2.
 *ACHTUNG: Die Lasereinheit nicht zerlegen.
 Die Lasereinheit darf nur gegen eine vom Hersteller spezifizierte Einheit ausgetauscht werden.

Ref. No.	Part No.	Part Name & Description	Remarks	Ref. No.	Part No.	Part Name & Description	Remarks
		PACKING MATERIAL		A6 *	RKB205ZA-0	EAR PADS	
				A7	SJP9223-1	POWER PLUG ADAPTOR	(GC) Δ
						<PRINTED CIRCUIT BOARDS	
						ASS'Y>	
P1	RPK0573	PACKING CASE		PCB1	REP2112C-M	MAIN P. C. B.	(RTL)
P2	RPF0111	PROTECTION BAG (UNIT)				<GREASE OR JIG/TOOL>	
P3	RPF0046	PROTECTION BAG (F. B.)				TEST DISCS	
P4	SQZD3	AREA LABEL	(E)	SA1	SZZP1054C	PLAYABILITY TEST DISC	
P4	SQZD7	AREA LABEL	(EB)	SA2	SZZP1056C	UNEVEN TEST DISC	
P4	SQZD6	AREA LABEL	(EG)			ALLEN WRENCH	
P4	RQLA0066	AREA LABEL	(GC)				
P4	RQLA0067	AREA LABEL	(GN)	SA3	SZZP1101C	ALLEN WRENCH (M2.0)	
		ACCESSORIES				LOCK PAINT	
A1	RFKSLXP160E	INSTRUCTION MANUAL ASS'Y	(E)				
A1	RQT2914-B	INSTRUCTION MANUAL	(EB, GN)	SA4	RZZ0L01	LOCK PAINT	
A1	RFKSLXP160EG	INSTRUCTION MANUAL ASS'Y	(EG)			GREASE	
A1	RFKSLXP160GC	INSTRUCTION MANUAL ASS'Y	(GC)	SA5	RFKXPG671	MOLYCOAT GREASE PG671	
A2	RFEA401E-1S	AC ADAPTOR	(E, EG) Δ				
A2	RFEA404B-W	AC ADAPTOR	(EB) Δ				
A2	RFEA402Z-W	AC ADAPTOR	(GC) Δ				
A2	RFEA404A-W	AC ADAPTOR	(GN) Δ				
A3	RFEV310A-KS	STEREO EARPHONES					
A4	RQA0013	WARRANTY CARD	(E, EB, EG)				
A4	RQX7433ZA	WARRANTY CARD	(GN)				
A5	RQCB0169	SERVICENTER LIST					

Notes: *This item is not attached to merchandise, but it is supplied as a replacement parts.
 • The marking (RTL) indicates that the Retention Time is limited for this item. After the discontinuation of this assembly in production, the item will continue to be available for a specific period of time. The retention period of availability is dependant on the type of assembly, and in accordance with the laws governing part and product retention.
 After the end of this period, the assembly will no longer be available.

PACKAGING

