

MODEL 8000 SERIES TWO LINEAR MOTOR TURNTABLE

Service Manual



Phase Linear®

8000 SERIES TWO
 LINEAR MOTOR ARM STEREO TURNTABLE

SERVICE MANUAL

CONTENTS:

	p.	p.	
1-0. SPECIFICATIONS	3	7-0. ADJUSTMENTS28
2-0. PANEL FACILITIES	4	7.1 D.D.Motor Operating Point Adjustment29
3-0. DISASSEMBLY:		7.2 Auto Lead-In Timing Adjustment29
3.1 Panel	8	7.3 End Sensor Sensi- tivity Adjustment29
3.2 Direct Drive Motor	9	7.4 End Timer Adjustment30
3.3 Tonearm	9	7.5 Tracking Sensor Zero Point30
3.4 CdS Detector & Lamp10	7.6 Tracking Sensor Gain Adjustment31
4-0. PARTS LOCATIONS11	7.7 Lead-In and Return Speed Adjustment31
5-0. BLOCK DIAGRAMS/OPERATIONS13	8-0. TIMING CHART	
5.1 Tonearm Control Stage15	9-0. TROUBLESHOOTING:	
5.2 End Detector Stage15	9.1 Circuit Block35
5.3 Arm EV Control Stage15	9.2 Mechanism Block44
5.4 Size Selector Stage15	10-0. EXPLODED VIEWS51
5.5 Repeat Control Stage16	10.1 Exterior53
5.6 Lowering Position Detector, Plunger Control Stage, and Descent Signal Generator16	10.2 Bottom (Base) Plate56
5.7 Display Stage and Plunger Driver16	10.3 Tonearm Assembly59
5.8 Manual Drive Stage16	10.4 EV Mechanism61
5.9 Tracking Sensor Stage and Tonearm Driver Stage16	11-0. PACKING62
5.10 D.D.Motor Control Stage and D.D.Motor Stop Control16	12-0. PRINTED CIRCUIT BOARD ASSEMBLIES63
6-0. CIRCUIT DESCRIPTIONS18		
6.1 Full Auto Logic18		
6.2 Tonearm Drive25		

* * * * *

THIS MANUAL IS INTENDED FOR USE ONLY BY QUALIFIED TECHNICAL SERVICE PERSONNEL. HAZARDOUS VOLTAGES MAY BE ENCOUNTERED IN THE TEST AND SERVICING OF THE 8000II. USE EXTREME CAUTION; READ ALL INSTRUCTIONS.

1-0.- SPECIFICATIONS

MOTOR AND TURNTABLE:

Drive System: direct drive
Motor: Quartz PLL Hall motor
Turntable Platter: 310mm diam.
aluminum alloy die-cast
Inertial Mass: 330kg-cm² (including platter mat mass)
Speeds: 33 1/3 and 45 RPM
Wow and Flutter:
less than 0.013% (WRMS)*
0.025% (WRMS)
0.035% (DIN)

(*) indicates wow and flutter for motor and does not include the cartridge or tone-arm load.

Signal-to-Noise Ratio:
more than 78dB (DIN-B)

ROTATIONAL CHARACTERISTICS:

Build-up Time: within 90° rotation at 33 1/3 RPM
Speed Deviation:
less than 0.002%
Speed vs. Load Characteristics:
stable up to 220 grams drag load
Speed Drift: less than 0.00008% per hour at 33 1/3 RPM; less than 0.00003% per degree of temperature change at 33 1/3

TONEARM:

Type: linear motor direct-drive; static-balance type; linear-tracking arm
Effective Arm Length: 190mm
Overhang: 0mm
Usable Cartridge Weight: 4g (min.) to 24g (max.)
Arm Height Adjust Range: ±3mm
Headshell Weight: 10.5g

SEMICONDUCTORS:

IC's22
Transistors17
Diodes16
Hall Elements3
LED's14
Photo Transistors5
CdS1

MISCELLANEOUS:

Power Requirements:
110-120vAC/50-60Hz only
Power Consumption: 35 watts
Weight: 26lb 8oz (12kg)
Dimensions:
19 7/16(w) x 6 1/16(h) x 17 15/16(d) in.
494(w) x 154(h) x 456(d) mm

SUBFUNCTIONS:

Auto Lead-In
Auto-Return
Auto Cut
Quick Repeat
Quick Play
Quick Stop
Stylus Pressure Direct Readout
Counterweight
Arm Height Adjusting Device
Cueing Device
Free Stop Hinges

NOTE: Specifications and design subject to possible modification without notice, due to improvements.

2-0: PANEL FACILITIES

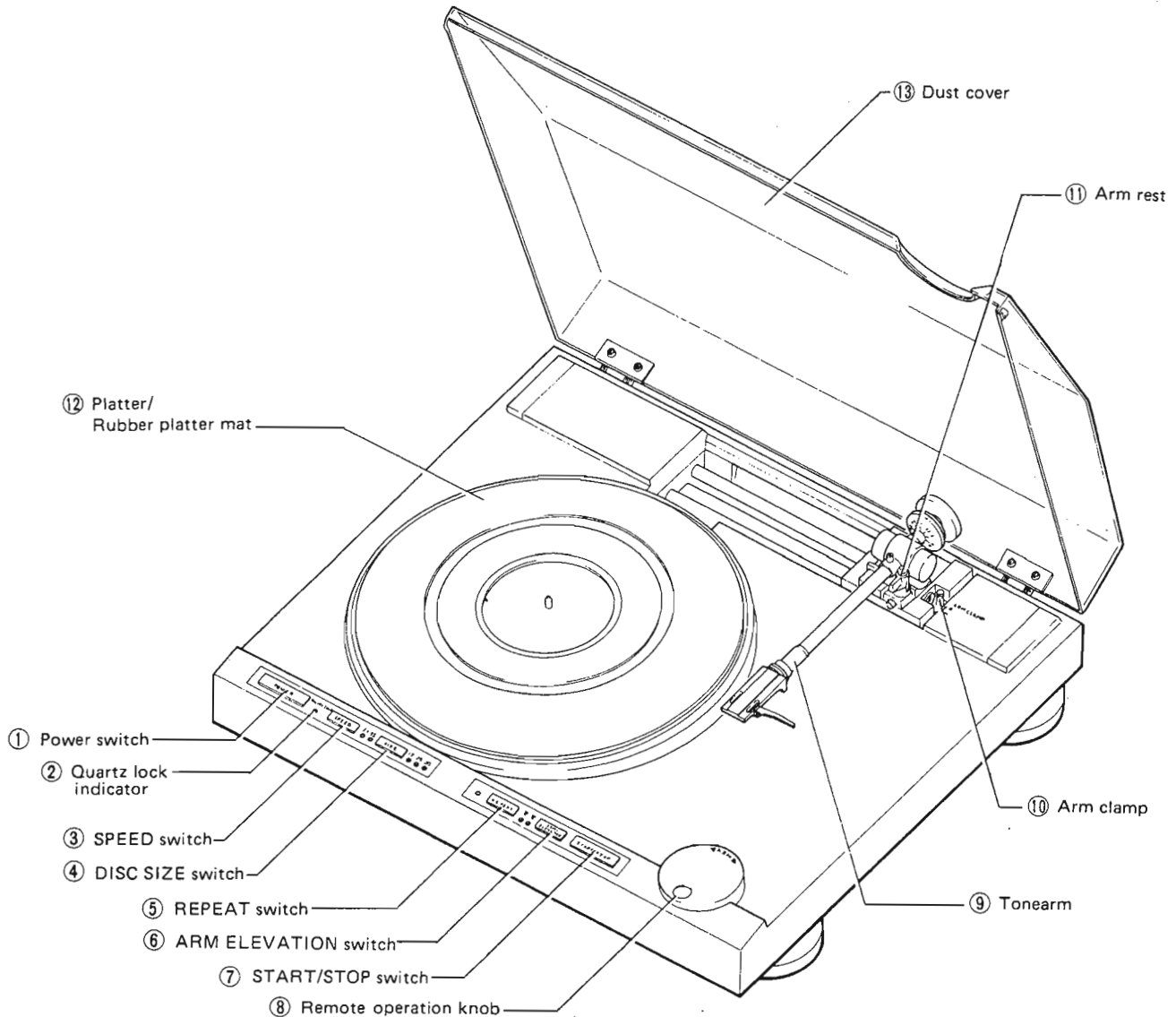

1. POWER SWITCH

Used to switch on and off the power to the turntable. Power is supplied when the switch is depressed (ON). The SPEED switch indicator (33) comes on. The power is switched off when the POWER switch is released.

NOTES: * The platter does not rotate when the tonearm is positioned at the far right even if the switch is depressed and the power is supplied.

* With each push, this switch alternates between the ON and OFF positions.

* Keep the POWER switch at the OFF position when you are not using the turntable.

2. QUARTZ LOCK INDICATOR

This indicator illuminates when the platter is revolving at the

specified rate of 33 1/3 or 45 RPM.

NOTE: If the platter speed varies, such as when the speed switch is changed from one position to another or when you press momentarily on the platter, the indicator will go off. As the platter revolution returns to the specified speed, the indicator will illuminate again.

3. SPEED SWITCH

33.....Set the switch to this position when playing a 33 1/3 RPM record such as an LP. When it is depressed, the 33 indicator lights up, and the platter rotates at a speed of 33 1/3 RPM.

45.....Set the switch to this position when playing a 45 RPM record like an EP. When it is depressed, the 45 indicator lights up, and the platter rotates at a speed of 45 RPM.

4. DISC SIZE SWITCH

Selects the switch that corresponds to the size of the record you want to hear for auto play operation.

12"30.....for 30cm records

10"25.....for 25cm records

7"17.....for 17cm records

* Used to select the record size when depressed. For instance, when the 30cm indicator lights up, depress the switch for the 25cm position, and depress it again for the 17cm position. Depressing the switch once more sets it to the 30cm position.

* When the power switch is turned ON, the turntable will always be set for records with a diameter of 30cm and the corresponding light will come on.

NOTE: This switch will not work if depressed when the tone-arm is moving (auto lead-in, auto-return, auto cut).

5. REPEAT SWITCH

Press this switch for repeat play. When pressed the indicator will light up, and the record will be played again (refer to page 16 for further details on repeat play). Press this switch again to release it. The indicator will go off and the repeat play function will be released.

NOTE: This switch will not work if depressed when the tone-arm is moving (auto-return, auto cut).

6. ARM ELEVATION SWITCH

Use this switch to interrupt play temporarily or to perform manual play.

When DOWN position is depressed the tonearm will descend and when the UP position is depressed the tonearm will rise. These two operations will be performed alternately every time the switch is pressed.

NOTES: * When the POWER switch is set to ON, the tonearm

will start in the UP position.

- * This switch will not work if depressed when the tonearm is moving (auto lead-in, auto-return, auto cut).
- * When the switch is at UP, the auto-return canceling mechanism is actuated and so there will be no auto-return.

7. STOP/START SWITCH

Press this switch for auto play. The platter will start to rotate, the tonearm will automatically move over to the edge of the record and play will begin (auto lead-in). If this switch is pressed during play, the tonearm will automatically return to the arm clamp position, the platter will stop rotating and play will be suspended (auto cut).

NOTE: This switch will not work if depressed when the tonearm is moving (auto lead-in).

8. REMOTE OPERATION KNOB

Used when moving the tonearm by remote control. Rotate counterclockwise to move the tonearm to the left. Rotate clockwise to move the tonearm to the right.

NOTE: When the arm elevation switch is at DOWN or auto lead-in, auto cut, and auto-return, the tonearm does not move even when the remote operation is released and the knob rotated.

9. TONEARM

The tonearm function is to apply the correct tracking force to the cartridge, maintain this value precisely, and allow the stylus to trace the record grooves accurately. The tonearm can be operated manually with your hand or remotely with the remote operation knob. It is coupled to the motor switch and when it moves across to the record the platter rotates and it stops when the tonearm is returned to the arm clamp position.

NOTE: When the POWER switch is at OFF, the tonearm cannot be moved by either manual or remote operation. If it is forced at the OFF position, this may result in damage so always remember to set the POWER switch to ON when moving it.

10. ARM CLAMP

Used to secure the tonearm.

To secure the tonearm, move it to the right and then push down on the clamp. When you do not intend to use the turntable, secure the tonearm in this way. The tonearm is released when the clamp is raised.

11. ARM REST

This secures the tonearm pipe. When playing a record, rotate the arm rest counterclockwise and release the clamp. When not playing a record, set the arm elevation switch to UP (▼) and then rotate the arm rest clockwise and secure the pipe.

NOTE: When the arm elevation switch is at DOWN (▼), the tonearm pipe cannot be secured. Make sure this switch is set to the UP (▲) position.

12. PLATTER/RUBBER PLATTER MAT

When the tonearm is moved and power is supplied to the turntable, the platter will start rotating at the set rotation speed. The rubber platter mat stabilized the records and also absorbs external vibration.

13. DUST COVER

Keep this closed unless operating the controls or tonearm, or changing records. This serves to keep dust off of the records during play. When fully opened and pulled straight up, this dust cover can be removed from the cabinet.

3-0. DISSASSEMBLY

3.1 Panel

1. Remove the four turntable feet.
2. Remove the four insulating mounting screws (8mm deep socket).
3. Remove the top cover (five phillips screws).
4. Shift the tonearm across to the center (far left).
5. Lift the panel up and disconnect the three connectors from the PC board below.

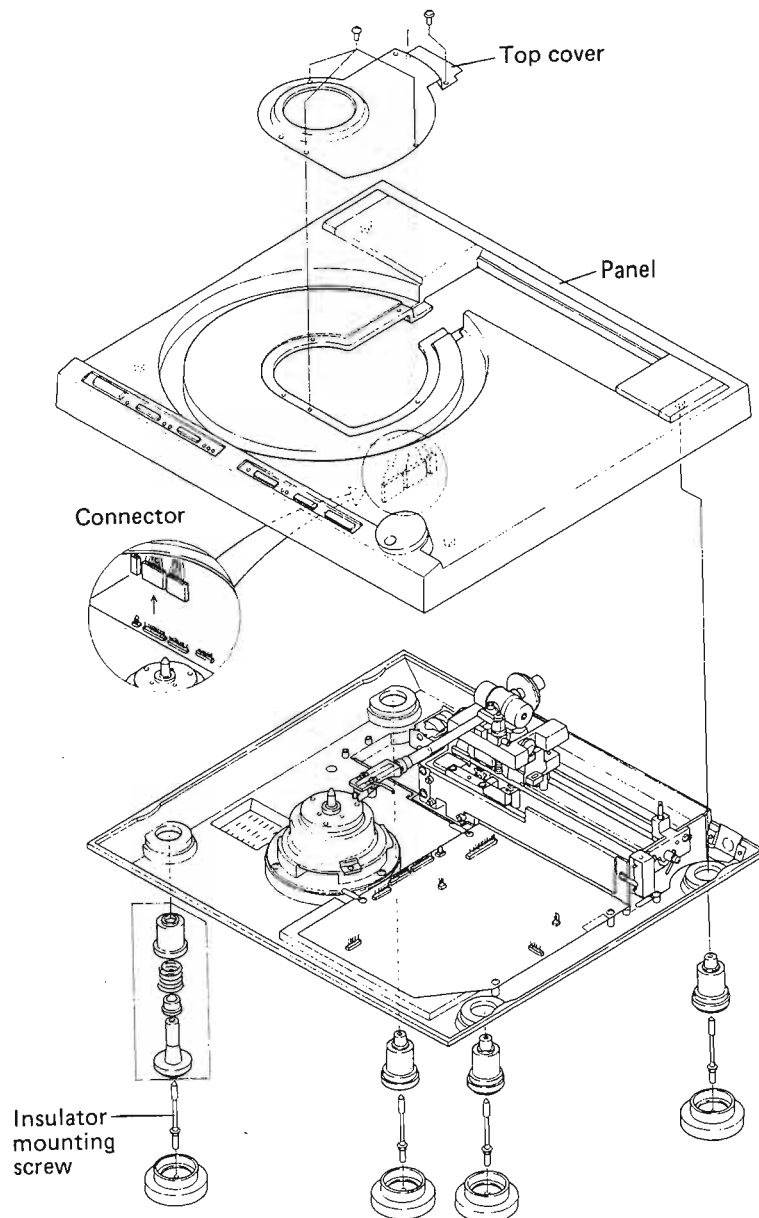

Fig. 3-1

3.2 Direct Drive Motor

1. Remove the three D.D. motor securing screws.
2. Disconnect the D.D. motor PC board connector.

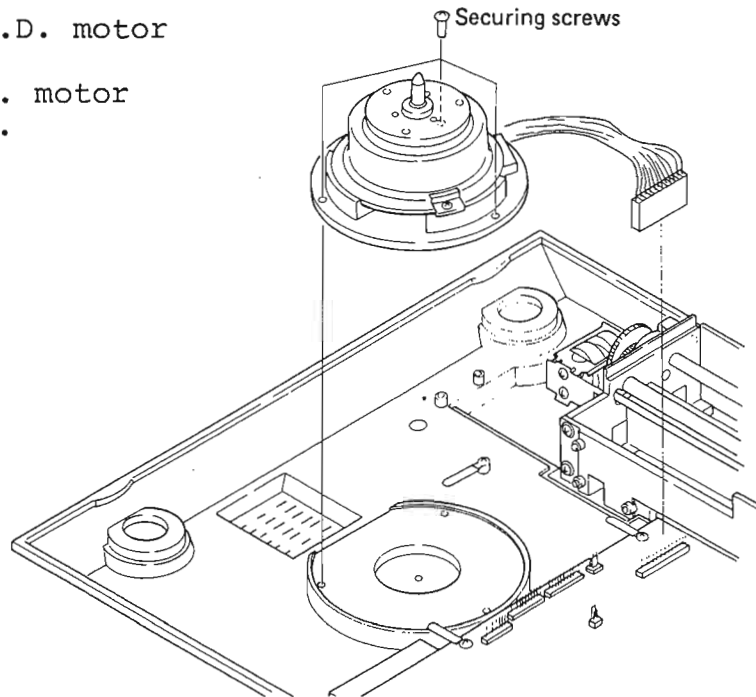

Fig. 3-2

3.3 Tonearm

1. Remove the plate pressing against the tonearm output cable.
2. Remove the coil and rail assembly.
3. Disconnect the ground lead connected to the front rail from PCB.
4. Remove the E-type washers and screw holding the gear and rail of the elevation mechanism. The front rail may then be removed by pulling out towards the right.
5. The other rail may also be removed by pulling out to the right after loosening the securing screw.
6. The tonearm may be removed once both rails have been pulled across to the right by at least 6 inches (15cm).

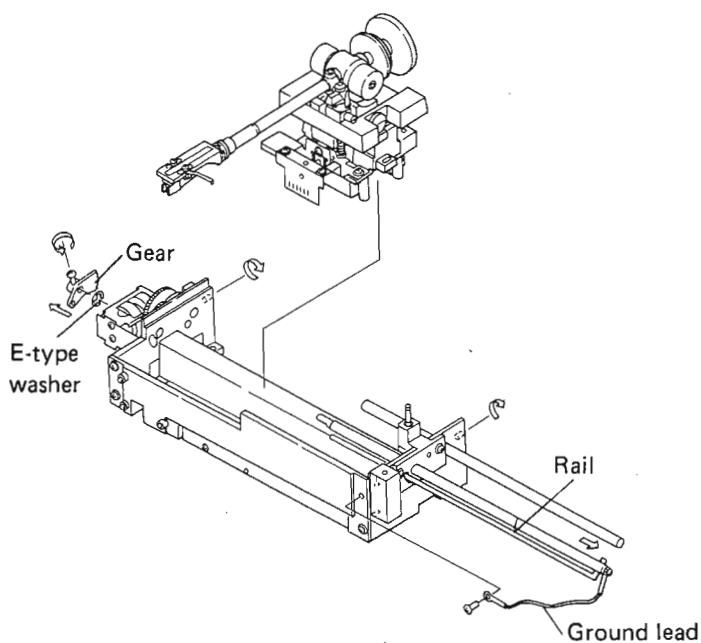

Fig. 3-3

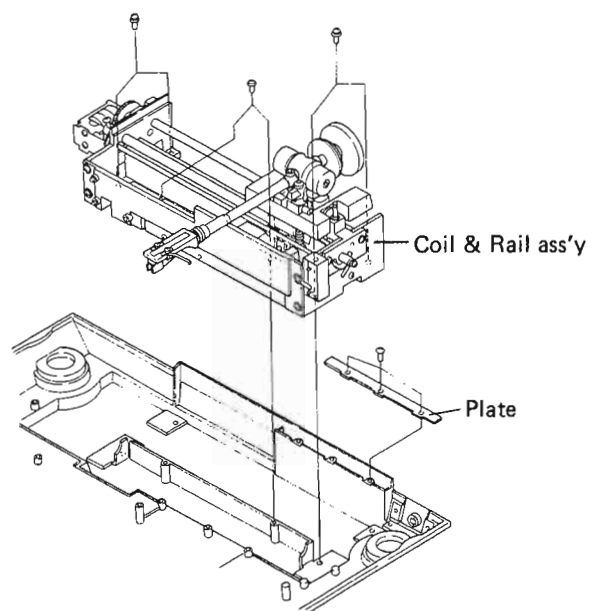
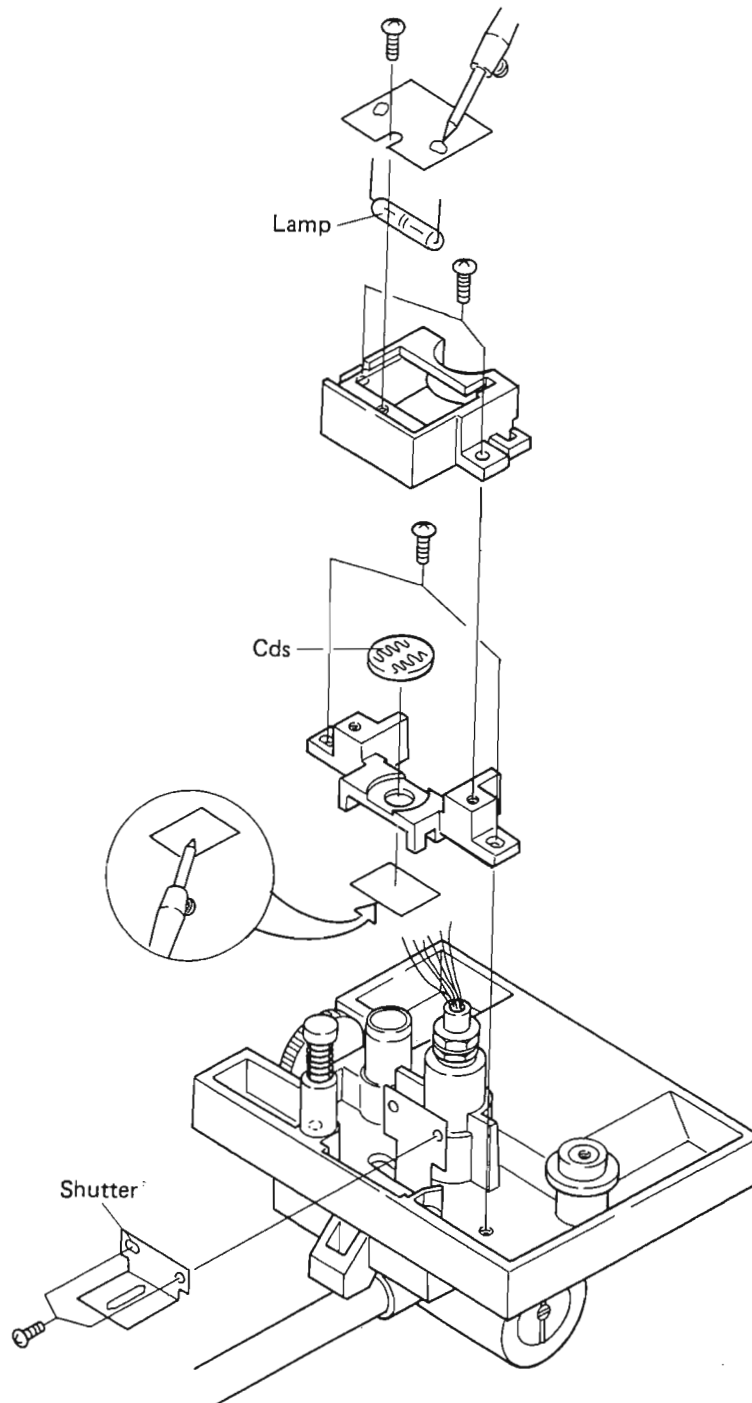

Fig. 3-4

3.4 CdS Detector and Lamp

1. After removing the tonearm, remove the CdS detector and lamp in the way indicated in Fig. 3-5.
2. Remove the shutter before removing the spacer securing the CdS detector.



4-0. PARTS LOCATIONS

- The Δ mark found on some component parts indicates the importance of the safety factor of the part. Therefore, when replacing, be sure to use parts of identical designation.

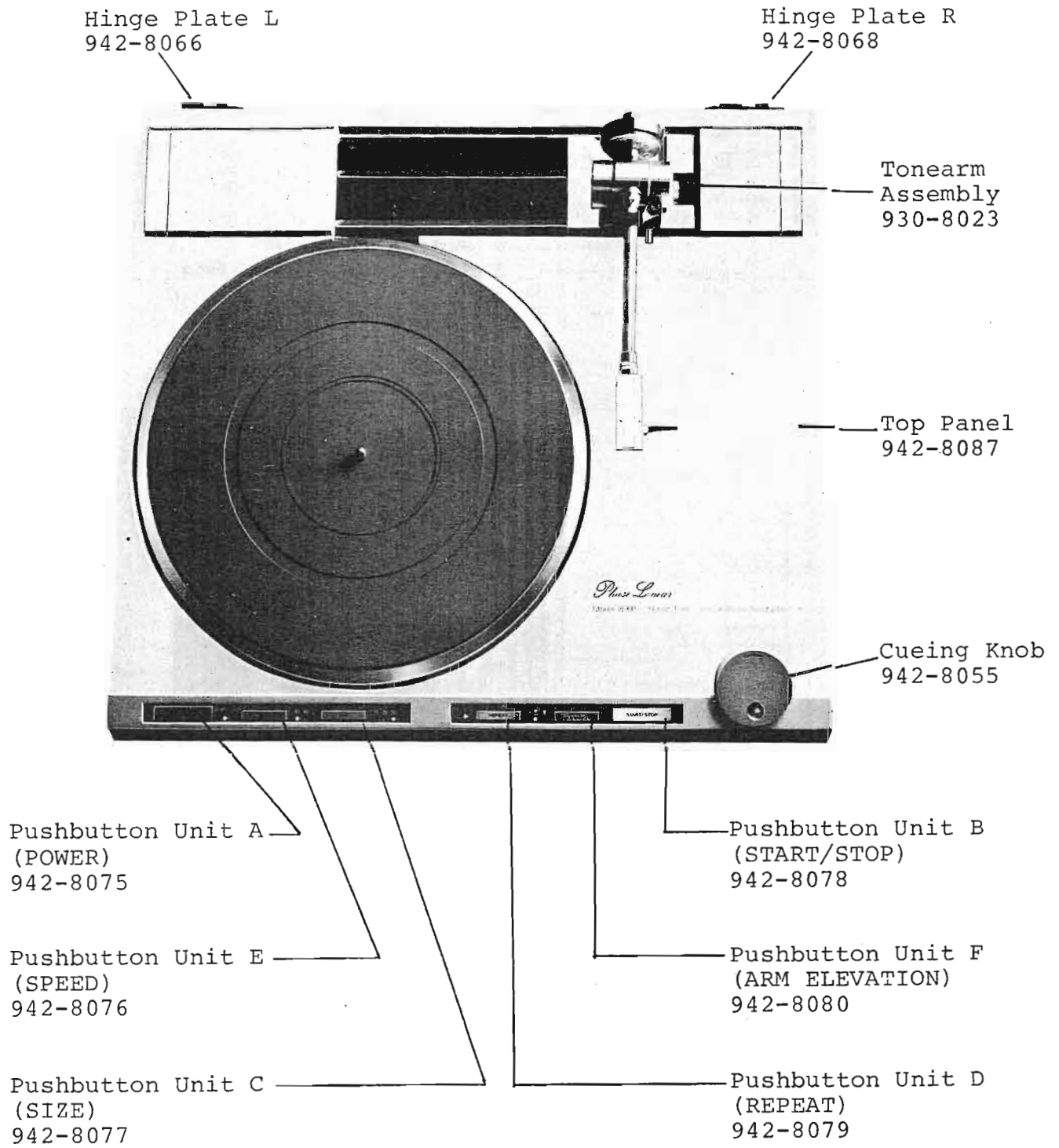

EV Mechanism Assembly

Coil Assembly
925-8030

Direct Drive
Motor
929-8021

Control PC
Board Assembly
901-8012

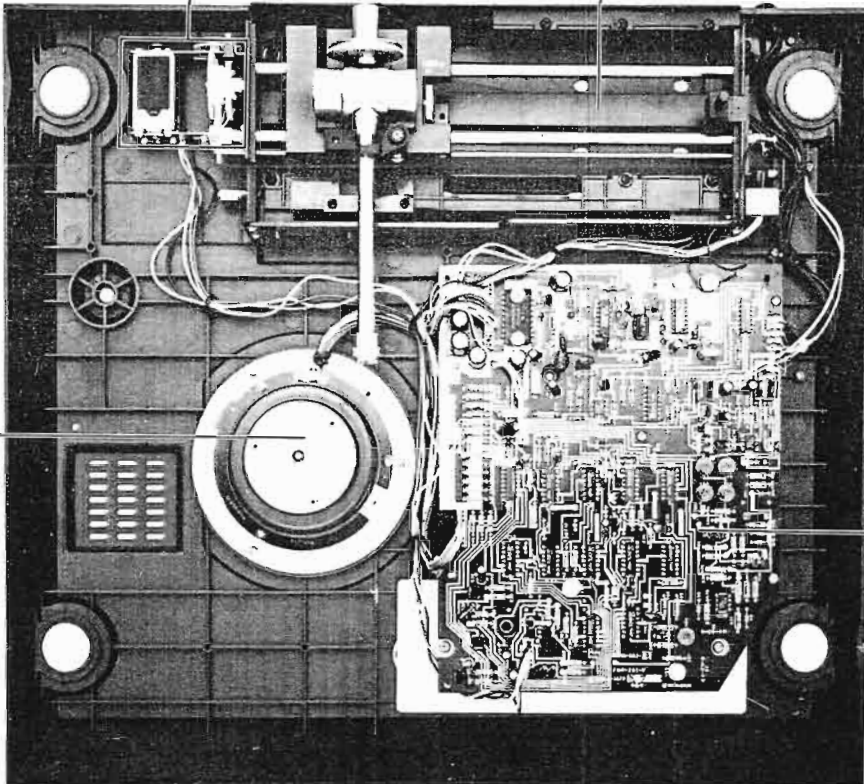

5. BLOCK DIAGRAM

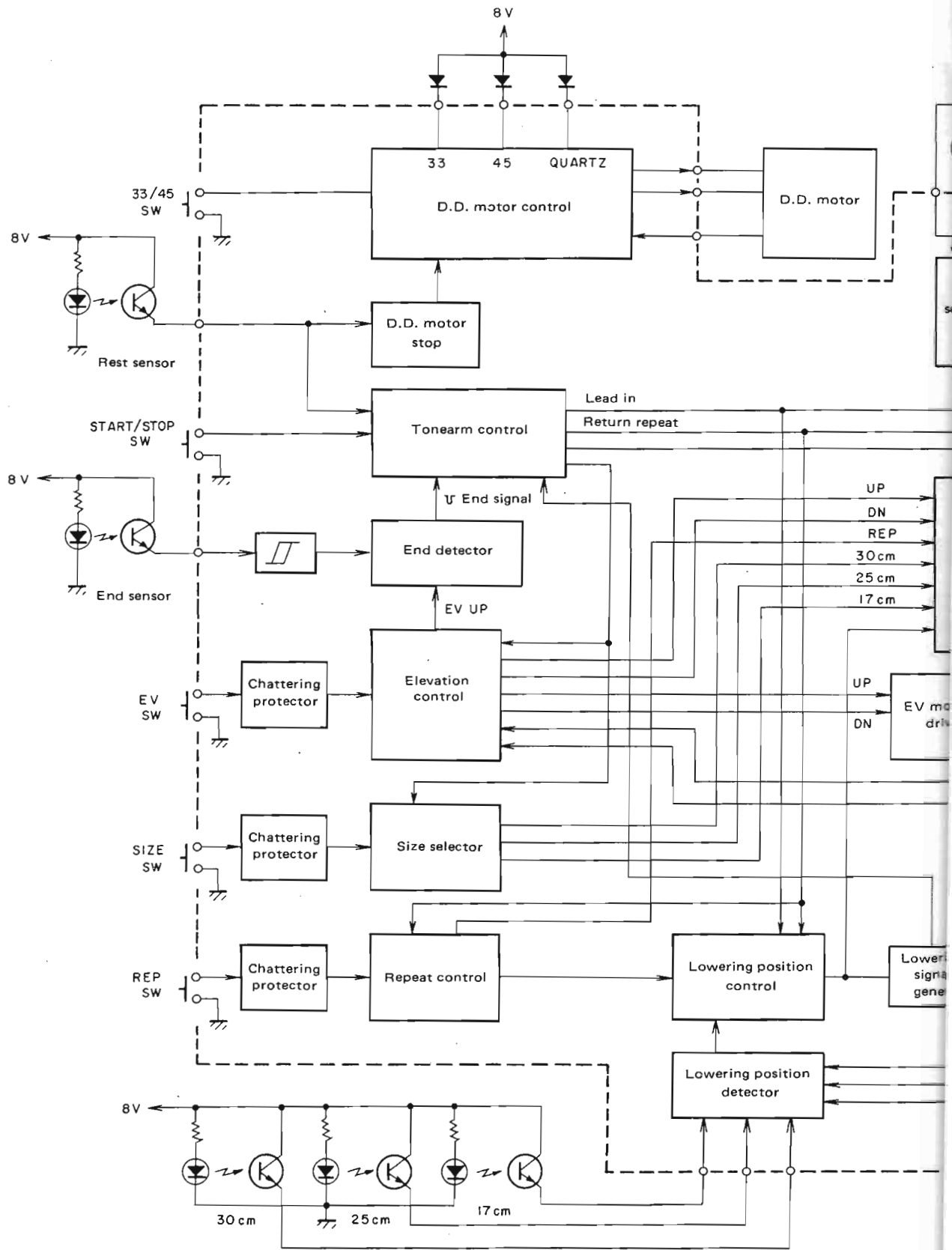

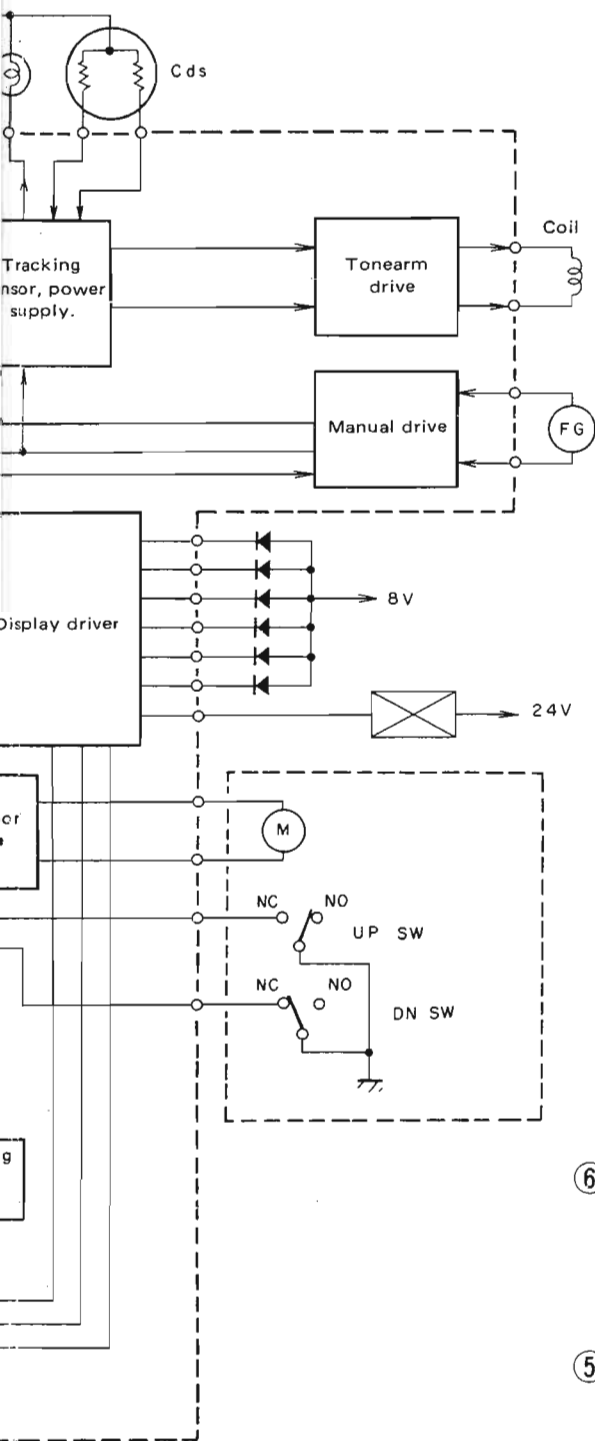

- 1 D.D. motor control
- 2 Tonearm control
- 3 Arm drive control
- 4 Full auto logic
- 5 Arm elevation control
- 6 EV, REPEAT, SIZE selector input

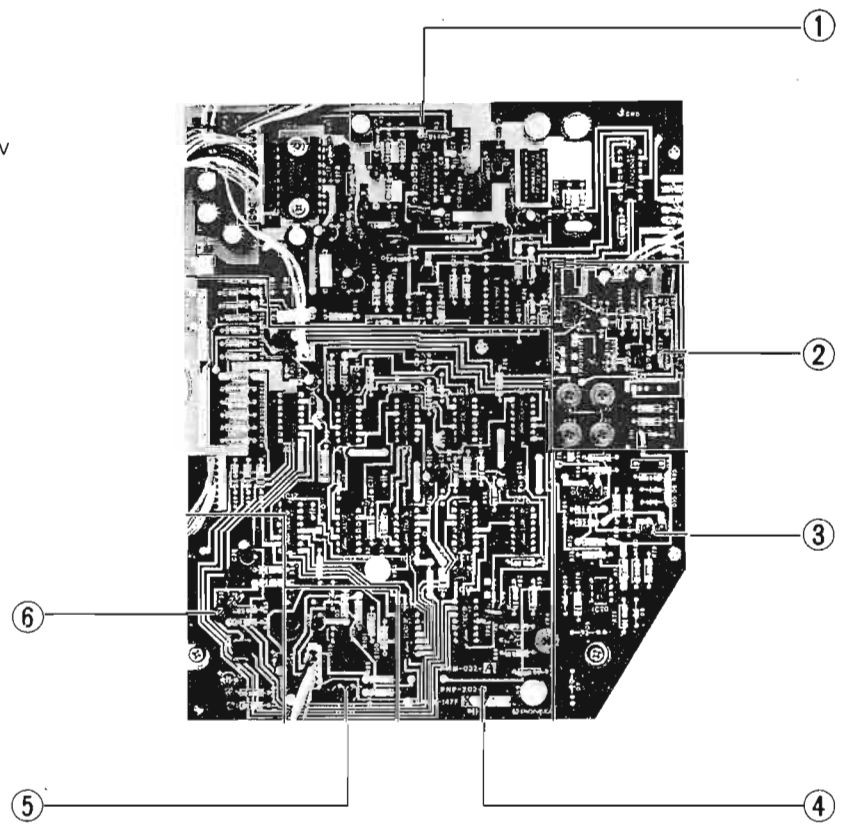

Photo 5-1

BLOCK DIAGRAM OPERATIONS

5.1 Tonearm Control Stage

a. Lead-in FF and Return FF (FlipFlop)

1. Lead-in FF....This FF is set by pressing the STOP/START switch when the tonearm is on the arm rest, and is reset by a descend signal, or when the power switch is turned on.

Return FF.....This FF is set by pressing the STOP/START switch when the tonearm is not on the arm rest, and also by the end detector. It is reset when the power is turned on, or by the descend signal, or when the tonearm returns to the arm rest.

- b. When either of the above two FF's has been set, an "AUTO on" signal is generated resulting in the arm elevator being set up to the UP position, and inhibition of manual drive.

5.2 End Detector Stage

The end sensor input signal is rectified and then applied to the detector stage consisting of a differential circuit, integration circuit, and a monostable multivibrator.

When the detector stage detects the arrival of two consecutive input signals within the fixed time constant period, an output signal is generated. This output, however, is inhibited by the EV UP signal when the arm elevator is in the UP position.

5.3 Arm Elevation Control Stage

This stage consists of a J-K-type FF with a reset (clear) input and preset input.

The arm elevator is raised (UP position) as a result of the initial resetting, or by the AUTO operation signal from the tonearm control stage.

The elevator descends again (DOWN position) when the FF is preset by the descend signal. Furthermore, whenever the EV switch is pressed, Q and \bar{Q} are generated alternately, resulting in the arm elevator being raised and lowered correspondingly.

The FF output is applied to a logical "and" circuit with the outputs from the elevator UP and DOWN switches, the resultant output being applied to the EV motor drive stage.

The FF output is applied to a logical "and" circuit with the outputs from the elevator UP and DOWN switches, the resultant output being applied to the EV motor drive stage.

5.4 Size Selector Stage

This stage consists of a J-K FF 2-stage ring counter and the Q1/Q2 logical "and" gate. As a result of the initial resetting, Q1=Q2=L for automatic switching of the size selector to the 30cm position. Every time the size selector switch is pressed after that, the selector is switched from the 30 to 25 and 17 positions

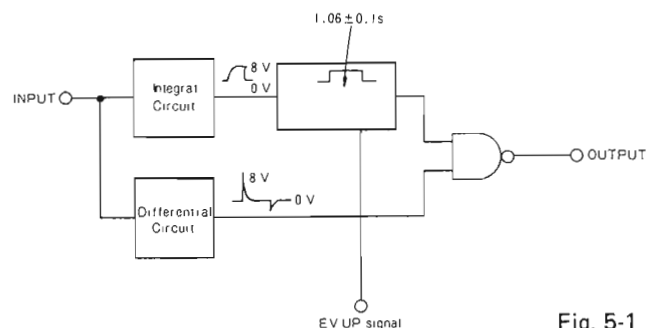

Fig. 5-1

in turn, and then back to 30 again. Note, however, that switching is inhibited when AUTO operation signals are received from the tonearm control stage (i.e. during lead-in, return, and repeat operations).

5.5 Repeat Control Stage

Consisting of a T-type FF, Q and \bar{Q} are inverted by REPEAT switch operation. Note that the FF is also turned off by the initial reset, and that there is no inversion while the tonearm control stage return FF remains set (i.e. during return and repeat operations). Furthermore, the FF is also turned off as a result of auto-cut operation during repeat mode.

5.6 Lowering Position Detector, Plunger Control Stage, and Descend Signal Generator

When the tonearm shutter passes between the sensors corresponding to the designated record size (sensors being mounted in positions corresponding to each record size), a lowering position detector output signal is generated. This signal is then applied to the plunger control stage (a monostable multivibrator), resulting in a fixed time constant pulse signal being generated to activate the plunger (during lead-in and repeat modes). The down stroke of the pulse signal is differentiated and a descend position signal is generated. Each of the tonearm control stage FF's is also cleared.

5.7 Display Stage and Plunger Driver

This stage is responsible for the LED display of elevator position, repeat mode, and selected record size, in addition to plunger drive.

5.8 Manual Drive Stage

By amplifying the input to the power generator motor mounted in the locate stage, the tracking sensor stage balance is upset, permitting the tonearm to be moved back and forth. Such operation is inhibited, however, when the elevator is DOWN during auto operation modes (lead-in, return, and repeat).

5.9 Tracking Sensor Stage and Tonearm Driver Stage

The tracking sensor stage (consisting of lamp, CdS element, and shutter) generates + and - voltage differences in response to tonearm movement. These output signals are then applied to the driver stage where they are amplified, and to pass a current through the drive coil to drive the tonearm in such a way as to eliminate tracking error (i.e. to avoid generation of tracking sensor outputs).

5.10 Direct Drive Motor Control Stage and Direct Drive Motor Stop Control

The phono motor stop control stage stops the motor when the rest sensor detects the presence of the tonearm back on the arm

rest. As long as the tonearm remains off the arm rest, the motor will continue to rotate. The phono motor control stage employs three specially designed IC's: PA2005, PA2004, and PD1003. These control stages also include the speed selector, speed indicator, and quartz lock indicator circuits.

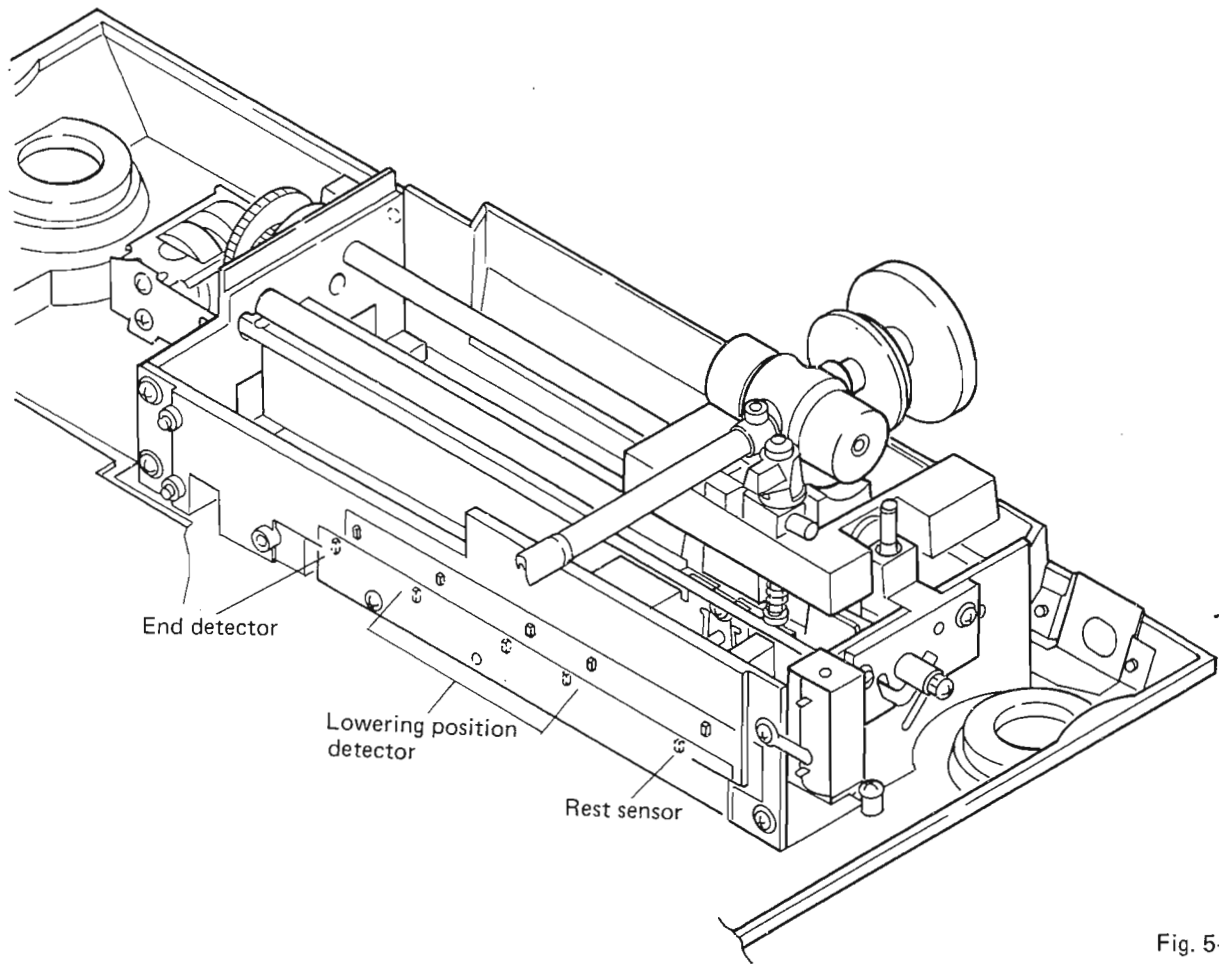

Fig. 5-2

CIRCUIT DESCRIPTIONS

6.1.1 Tonearm Control Stage

1. When the power switch is turned on....
 -the lead-in FF and return FF are reset by the initial reset signal (passed from C29/R55 to IC16, to IC17, to IC19 and IC10).
 -the phono motor will remain stationary if the tonearm is on the arm rest, but commence to rotate if it has already been moved away.

 2. When the STOP/START switch is then pressed with the tonearm on the arm rest,
 - * pin 8 of IC8 is switched to L level.
 - * Pin 10 of IC8 is switched to H level, and this appears at pin 3 of IC10, resulting in the lead-in FF being set (and pin 10 of IC10 also being switched to H level).
 - * Once pin 10 of IC10 is switched to H level, pin 3 of IC8 is switched to L level, resulting in pin 8 of IC11 being likewise switched to L level thereby inhibiting manual drive (locate operation).
Pin 13 of IC14 is also switched to L level, resulting in pin 12 of IC12 being switched to H level, and the elevator being consequently raised to the UP position.
 - * Pin 4 of IC11 is switched to H level, resulting in the inhibition of any further START/STOP switch inputs after a delay of about 1ms (in order to prevent the return FF from being set when the tonearm leaves the arm rest). At the same time, pin 12 of IC18 is switched to H level to inhibit switching of the size selector.
Hence, the relevant FF's are set, the arm elevator raised, and record size selector switching inhibited.
 - * Pin 11 of IC10 is switched to L, and this is transferred to pin 6 of IC8. Once the elevator is properly in the UP position, the UP detector switch is switched to the ON position, resulting in pin 5 of IC8 being switched to L level, and pin 4 of IC8 switched to H level.
 - * This IC8 pin 4 H level signal then turns Q7 on, resulting in a current being passed from VR8 to VR5 and R99 via R93. If the potential at TP8 drops below the potential at TP10, the difference is amplified and a current passed through the coil to subsequently drive the carrier.
The carrier is thus shifted across towards the record (assume size selector set to 30cm).
 - * When the carrier reaches a position about 20mm in front of the 30cm position, the carrier shutter will block the light of the 30cm sensor.
 - * Pin 13 of IC9 is thereby switched to L level, and pin 10 of IC9 switched to H level. This serves as a trigger for the monostable multivibrator incorporated in IC13, resulting in the generation of an H level signal of $t=2.2$ seconds. This is applied to TP3 and pin 9 of IC12, presetting the EV FF for lowering of the tonearm.
 - * The TP3 H level signal is used to drive IC7, and in turn attracts the plunger and raise the index plate.
- The carrier continues to move further, coming to a stop when

6. CIRCUIT DESCRIPTIONS

6.1 FULL AUTO LOGIC

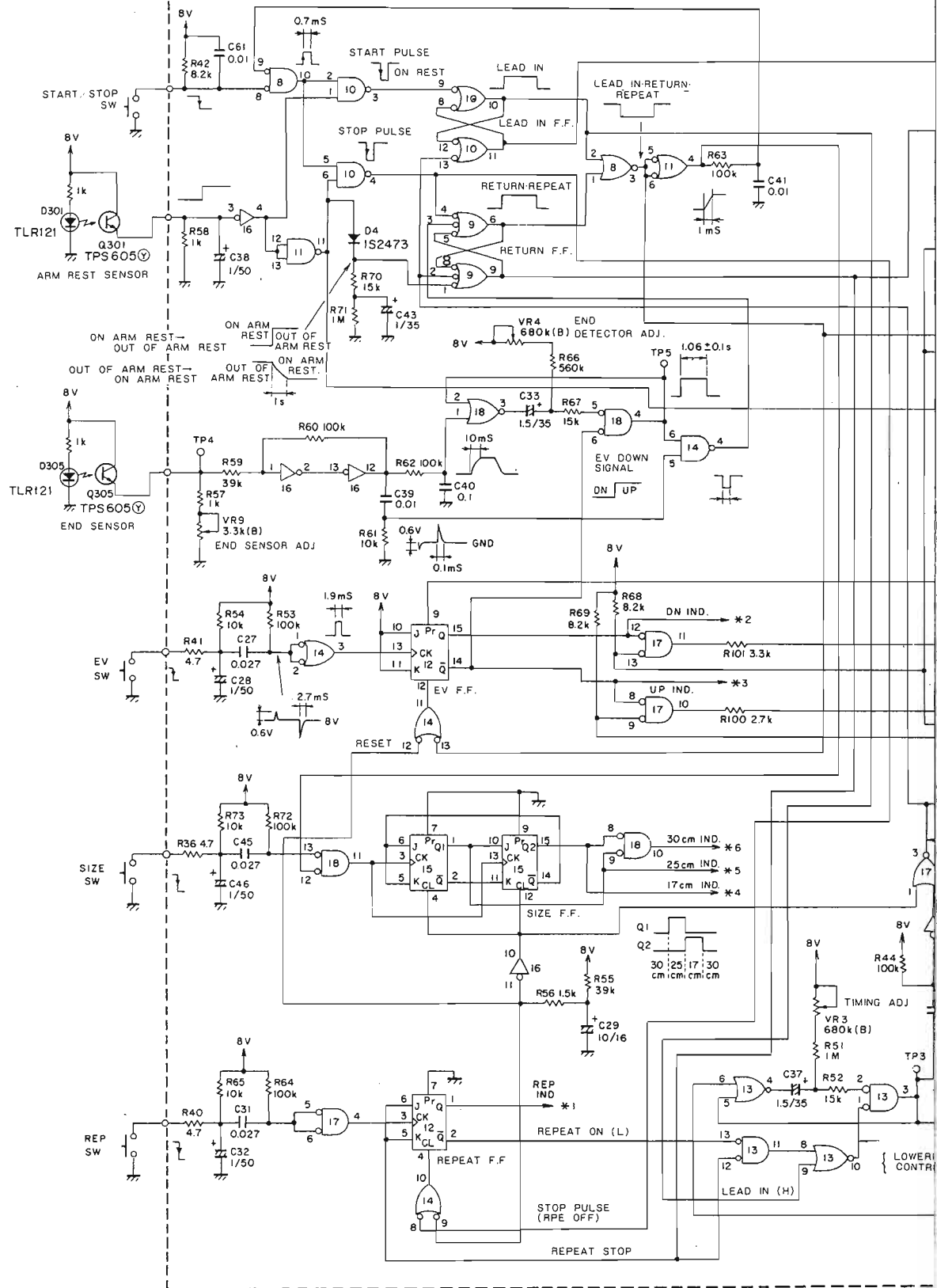

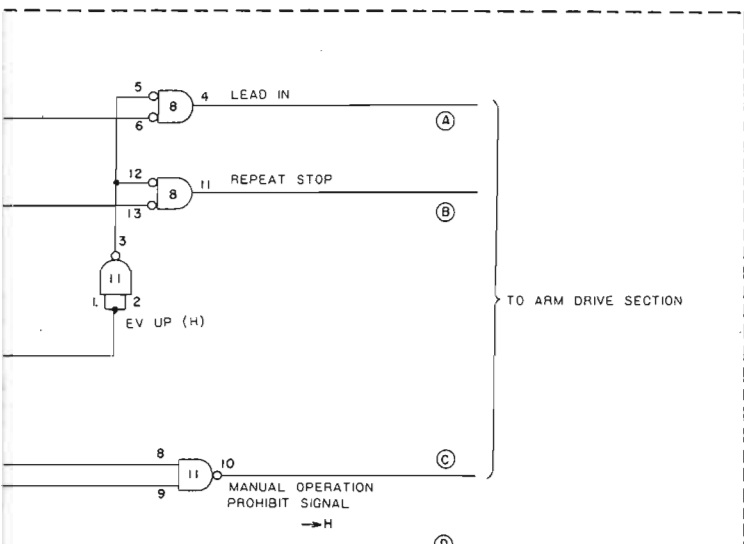

NOTES:

- * L denotes L level.
- * H denotes H level.
- * EV denotes arm elevator, UP denotes that arm elevator is in UP position, while DN denotes that elevator is in the DOWN position.

The Full Auto Logic section is made up of the following five main stages:

- (1) Tonearm control stage
- (2) End detector stage
- (3) Elevation control stage
- (4) Record size selector stage
- (5) Repeat control stage

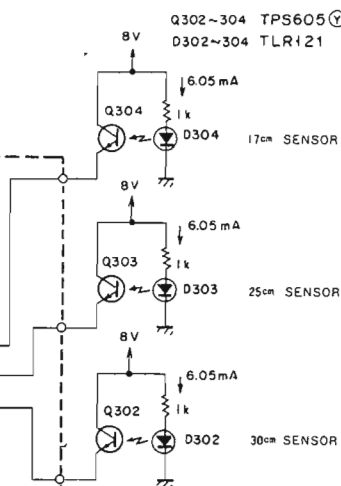
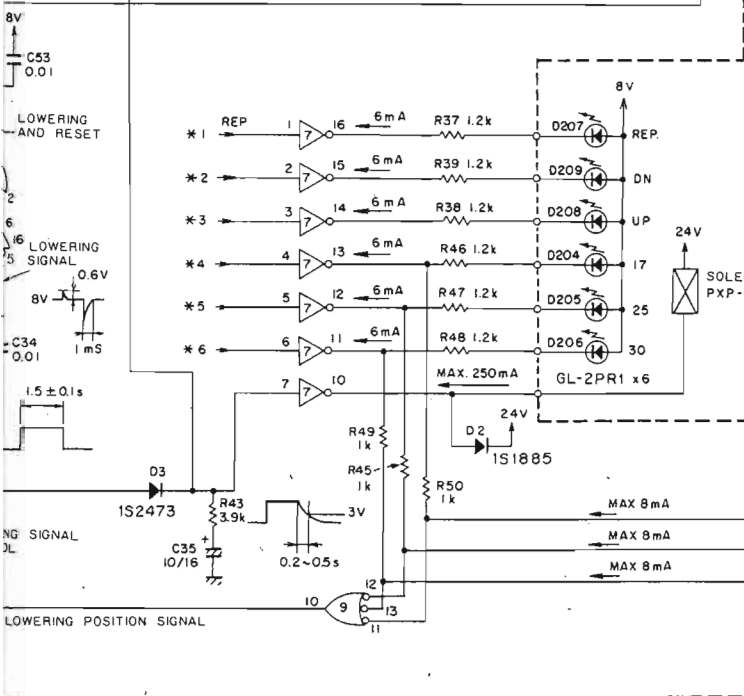
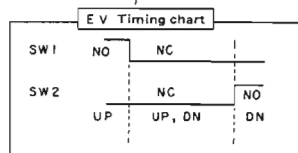
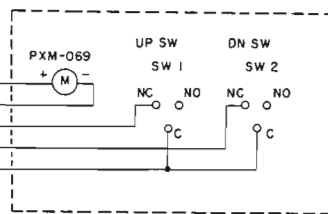
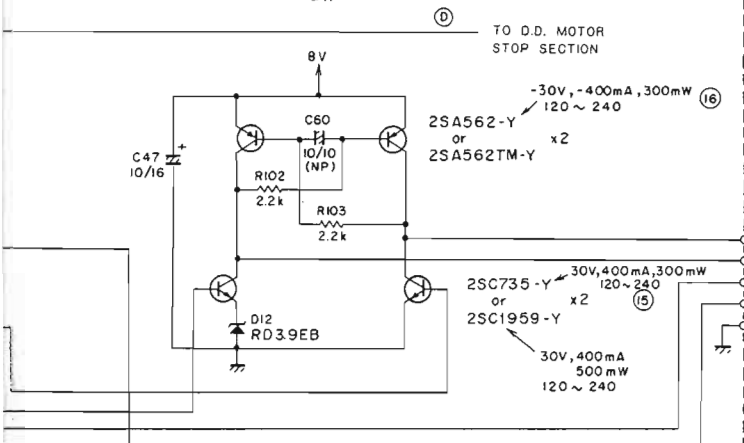

- the swing pin strikes the index plate.
- * TP3 is switched back to L level 2.2 seconds later, the signal being differentiated by C34 and R44 to provide the tonearm descend signal which is passed via IC17, IC9, and IC10 to clear the FF's and stop the carrier drive current. The elevator UP, locate inhibition, and size selector switching inhibition are also cancelled at the same time.
 - * As a further result of TP3 being switched to L level, the charge held by C35 is discharged via R43 and the IC7 base resistance. During this discharge period (0.3 to 0.5 sec.) the plunger is maintained in the attracted position, but is forced back (by a spring) once the discharge has been completed. The elevator is thereby returned to DOWN position for start of play.
3. START/STOP switch pressed when tonearm is not on the arm rest.
- * Pin 8 of IC8 is switched to L level.
 - * The IC8 pin 10 change to H level results in pin 4 of IC10 being changed to L level for the return FF to be set.
 - * This then results in the elevator being raised, and inhibition of size selector switching, S/S switch input after a delay of 1mS, and locate.
 - * The L level signal on pin 9 of IC9 is transferred to pins 5 and 6 of IC12, thereby inhibiting inversion of the repeat FF. Furthermore, the IC10 pin 4 L level change is transferred to pin 4 of IC12 via pin 8 of IC14 to clear the repeat FF. The purpose of the 1mS delay circuit referred to above is to permit sufficient time for the generation of the time pulse employed in clearing this FF.
 - * In a similar fashion to the lead-in operation, the L level signal appearing at pin 9 of IC9 once the elevator has been completely raised, is converted into an H signal at pin 11 of IC8, resulting in Q8 being turned on. In this case, however, the TP10 potential drops below the TP8 potential, resulting in the carrier being returned towards the arm rest.
 - * When the shutter cuts across the sensor light beam during the return motion, pin 10 of IC9 is switched to H level, but since the repeat mode has been switched off, pin 1 of IC13 will be at H level, thereby preventing operation of the monostable multivibrator.
 - * Once the carrier reaches the arm rest position, the rest sensor transfers an L level signal to pin 3 of IC16, resulting in pin 11 of IC11 being switched to L level to stop the phono motor.
 - * When pin 11 of IC11 is switched to L level, the charge stored on C43 is discharged via R71, the return FF being cleared after the potential on pin 1 of IC9 is reduced to $\frac{1}{2}V_{CC}$ (delay circuit). During this period, the carrier remains pressed against the arm rest.
4. End Detector Operation
- * When the repeat mode is off, pin 3 of IC9 is switched to L level by the end detector, and the return FF is consequently set. Subsequent steps are the same as during normal return mode.

* When the repeat mode is on, the return FF is again set in the same way for normal return operation. However, when the shutter cuts across the size sensor, the plunger is activated (TP3 switched to H level), followed by the generation of the descend signal in the same way as during lead-in. The elevator is thus lowered for recommencement of play.

6.1.2 End Detector Stage

1. Detector Principle

* Shutter structure:

The detector circuit (outlined in the block diagram) has been designed to detect the presence of two rising edges of the Schmitt circuit output within 1.06, ± 0.1 seconds.

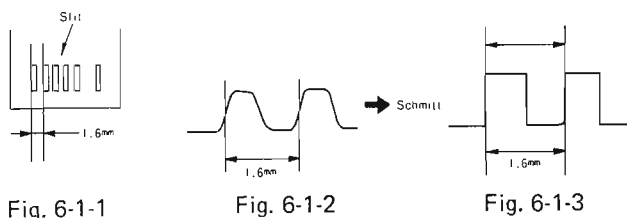

Fig. 6-1-1

Fig. 6-1-2

Fig. 6-1-3

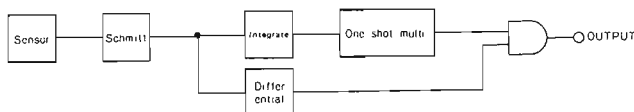

Fig. 6-2

2. Circuit Description

The end sensor is mounted at a position R49mm from the spindle. When the left edge of the shutter slits reaches that position, the stylus tip will be at the R62.5mm position. That is, there is 20mm between the 62.5mm position and the point of entry into the detection range. Once the detection range is entered, the sensor commences to generate output signals with a waveform like that shown in Fig.6-1-2 above. This output is applied to the Schmitt trigger circuit composed of two inverters in IC16 where it is rectified into the square wave as shown in Fig.6-1-3. This output is then differentiated by C39/R61 and applied to pin 5 of IC14, while another portion of the same output is integrated by R62/C40 and applied to the monostable multivibrator composed of two NOR gates in IC18, resulting in the generation of a 1.06, ± 1 second H level signal (TP5). Although this signal is applied to pin 6 of IC14, there is no detection by pin 5 because of the delay by the integration circuit. If, however, the next differential pulse is applied to pin 5 of IC14 while the H signal is being generated at TP5, that pulse will be detected. Apart from this case, there is no detection because the differential pulse involves a slight delay before switching TP5 to H level.

Furthermore, when the elevator FF \bar{Q} is connected to pin 6 of IC18 to make $\bar{Q}=H$ (i.e. UP position), the monostable multivibrator is inhibited, thereby inhibiting the detector circuit. $\bar{Q}=H$ also when the power switch is turned on, again inhibiting the multivibrator.

6.1.3 Elevation Control Stage

* When the power switch is turned on, an initial reset signal is passed to pin 12 of IC14 from R55/C29, resulting in pin 11 of IC14 and pin 14 of IC12 being switched to H level ($\bar{Q}=H$). This corresponds to the elevator being in the UP position, or in other words, UP priority is given when the power is first turned on.

- * Since $\bar{Q} = H$, one of the IC7 transistors will be turned on to light up the UP indicator LED.
 - * Until the elevator reaches the UP position the UP detector switch remains in the normally closed (NC) position, resulting in pins 13 and 12 of IC17 being both switched to L level, and Q13 and Q16 of the elevator drive stage being both turned on to start up the motor.
 - * Once the elevator is properly in the UP position, the UP detector switch is switched to the normally open (NO) position resulting in pin 13 of IC17 being switched to H level, and pin 11 of IC17 being switched to L level. Q13 and Q16 are both turned off and the motor stopped.
 - * If the elevator switch is then pressed, a falling edge of differential pulse is generated on pins 1 and 2 of IC14, and a rising edge clock pulse on pin 13 of IC12. This results in $Q = H$ and $\bar{Q} = L$ for lowering of the elevator (DN).
 - * And since $Q = H$, the DN indicator LED will be lit up, and the UP indicator turned off.
 - * The DN detector switch remains in the NC position until the elevator is right down. During this period, pins 9 and 8 of IC17 will be both at L level, while pin 10 of IC17 will be at H level. The elevator drive stage Q14 and Q15 will thus be on and the motor rotating.
 - * If the elevator switch is pressed during this condition, Q will switch to L and \bar{Q} to H (UP) to reverse the motor.
- The above description relates to the operation of the elevator circuit itself. In addition,
- * automatic mode UP (as described under the tonearm control stage), and
 - * DN at the lowering position, may be controlled via the elevator FF preset and clear terminals.

6.1.4 Record Size Selector Stage

- * When the power is turned on, the initial reset signal from R55/C29 is passed to IC16 to switch pin 11 to H level, resulting in IC15 being cleared.
- * Pin 1 (Q1) and pin 15 (Q2) of IC15 are both switched to L level, this then being transferred to pins 8 and 9 of IC18. Pin 10 of IC18 is thus switched to H level and the 30cm indicator LED is lit up.
- * If the size selector is then pressed, the falling edge differential pulse applied to pin 13 of IC18 when pin 12 of this IC was at L level (i.e. when none of the lead-in, return, or repeat modes were operative), is instead applied to pin 11 of IC18 as a rising edge clock pulse, thereby activating the ring counter in IC15. As a result, $Q1 = H$ and $Q2 = L$. The 30cm indicator LED is turned off, and the 25cm indicator LED turned on.
- * If the size selector is pressed again, the 17dm indicator LED is turned on. Every time the selector is pressed, the size is switched in a cyclic order 30 to 25 to 17 to 30...

6.1.5 Repeat Control Stage

- * When the power is turned on, the initial reset signal from R55/C29 is applied to pin 8 of IC14, resulting in pin 10 of this IC being switched to H level, and pin 1 (Q) of IC12

being switched to L level.

- * The repeat indicator LED will thus be turned off (since $Q=L$).
- * If the repeat switch is then pressed, a falling edge differential pulse will be applied to pins 5 and 6 of IC17, and a rising edge clock pulse generated at pin 4. As long as the repeat or return modes are not operative at this time, pin 5 (K) and 6 (J) of IC12 will both be at H level, resulting in $Q = H$, and $\bar{Q} = L$ for the repeat indicator LED to be turned on. At the same time, pin 13 of IC13 is switched to L level, thereby enabling the monostable multivibrator consisting of two gate circuits in IC13 to operate during repeat.
- * If the repeat switch is then pressed again, the $J = K = H$ status will be inverted.

In addition to the above repeat control stage,

- * The START/STOP switch may be pressed to activate return mode. In this case, a falling edge pulse is generated on pin 8 of IC14. Pin 10 of IC14 is thus switched to H level, and the IC12 FF cleared (repeat off), resulting in $Q = L$ and $\bar{Q} = H$.
- * When the return FF is set (during return or repeat mode), pin 9 of IC9 is switched to L level, this being transferred to the J and K terminals of the repeat FF, thereby inhibiting any inversion.

6.2 TONEARM DRIVE

The tonearm drive stage contains the following three major component circuits:

- (1) Tracking sensor circuit
- (2) Tonearm drive circuit
- (3) Manual operation circuit (locate operation circuit)

6.2.1 Tracking Sensor Circuit

An outline of the tracking sensor circuit is shown on page 27. When the stylus is positioned exactly at right angles to the carrier, the lamp beam is directed practically equally onto both CdS elements, which means that the resistance in both elements will also be more or less equal. These two elements form part of a Wheatstone bridge with R93, R94, and VR8, this latter variable control being adjusted so that no potential difference is generated across TP8 and TP10 when the stylus is located at right angles to the carrier. If the stylus should happen to move to either left or right, the amount of light striking the CdS elements will change, resulting in the resistance of one element being increased, and the resistance in the other element being decreased. A potential difference will thus be generated across TP8 and TP10. The relation between stylus movement and the potential difference generated is shown in Fig. 6-4. VR7 is used for adjustment purposes.

- * When the stylus is positioned at right angles to the carrier, the bridge is balanced, and the carrier remains stationary.
- * If the stylus should tend towards the left of the carrier, a (+) potential will be generated across TP8 and TP10. This signal is amplified in the tonearm drive circuit (see section 6.2.2), resulting in a coil current to move the carrier to the left (during record trace, or when moved to the left by hand).
- * If the stylus should happen to tend towards the right, a (-) potential will be generated across TP8 and TP10. After amplification in the tonearm drive circuit, the resultant coil current serves to move the carrier to the right (during record trace, or when moved to the right by hand).
- * During lead-in Q7 is turned on, and a current is passed from R93 to R99 via VR5. A (+) potential difference is generated between TP8 and TP10 by the voltage drop across R93, resulting in the carrier being moved to the left. Speed is controlled by adjusting the current passing through VR5.
- * During return and repeat modes, Q8 is turned on, resulting in a current being passed from R94 to R98 via VR6. Consequently, a (-) potential difference is generated between TP8 and TP10 by the voltage drop across R94, thereby moving the carrier to the right. In this case, speed is controlled by adjusting the current passing through VR6.

6.2.2 Tonearm Drive Circuit

The tonearm drive circuit consists of a current booster formed by a differential amplifier and Q's 9 through 12. The DC voltage created by the CdS element when the stylus tends toward the left or right is amplified by differential op amp IC21 and current boosters Q9, Q10, Q11, and Q12. This voltage is then passed on

to the linear motor drive coil. The drive voltage is temperature compensated by thermistors TH1 and TH2.

6.2.3 Manual Operation Circuit (locate Operation Circuit)

- * When elevator is not completely in the UP position (UP detector switch in the NC position),
- * During automatic modes (lead-in, return, repeat).

Under the above conditions, pin 10 of IC11 in the full auto logic stage is switched to H level, thereby turning Q4 and Q5 on. The collector voltage of these two transistors will thus be almost zero. Current will also flow through the D10 - R82 - Q4 and D9 - R81 - Q5 routes, resulting in the base of Q6 being biased in the reverse direction due to the voltage drop of V_f of D9 and D10 in respect to the emitter. Q6 is thus turned off to inhibit locate operation.

- * When locate dial is rotated,
- * When the motor generates power,
- * When the motor RPM is low (slow rotation of the dial), the amplifier gain is determined by $\frac{R76 + R77}{R78} + 1$,

but once the motor RPM is increased by a certain rate, the gain will be clamped by the voltage determined by D7 and D8, or D5 and D6.

- * When the differential amplifier is activated, one side of Q6 is turned on according to the rotational direction of the dial, resulting in a voltage drop across R93 or R94, and the generation of a potential difference between TP8 and TP10. This is subsequently amplified, and results in a current being passed through the coil to move the carrier.

6.2 TONEARM DRIVE

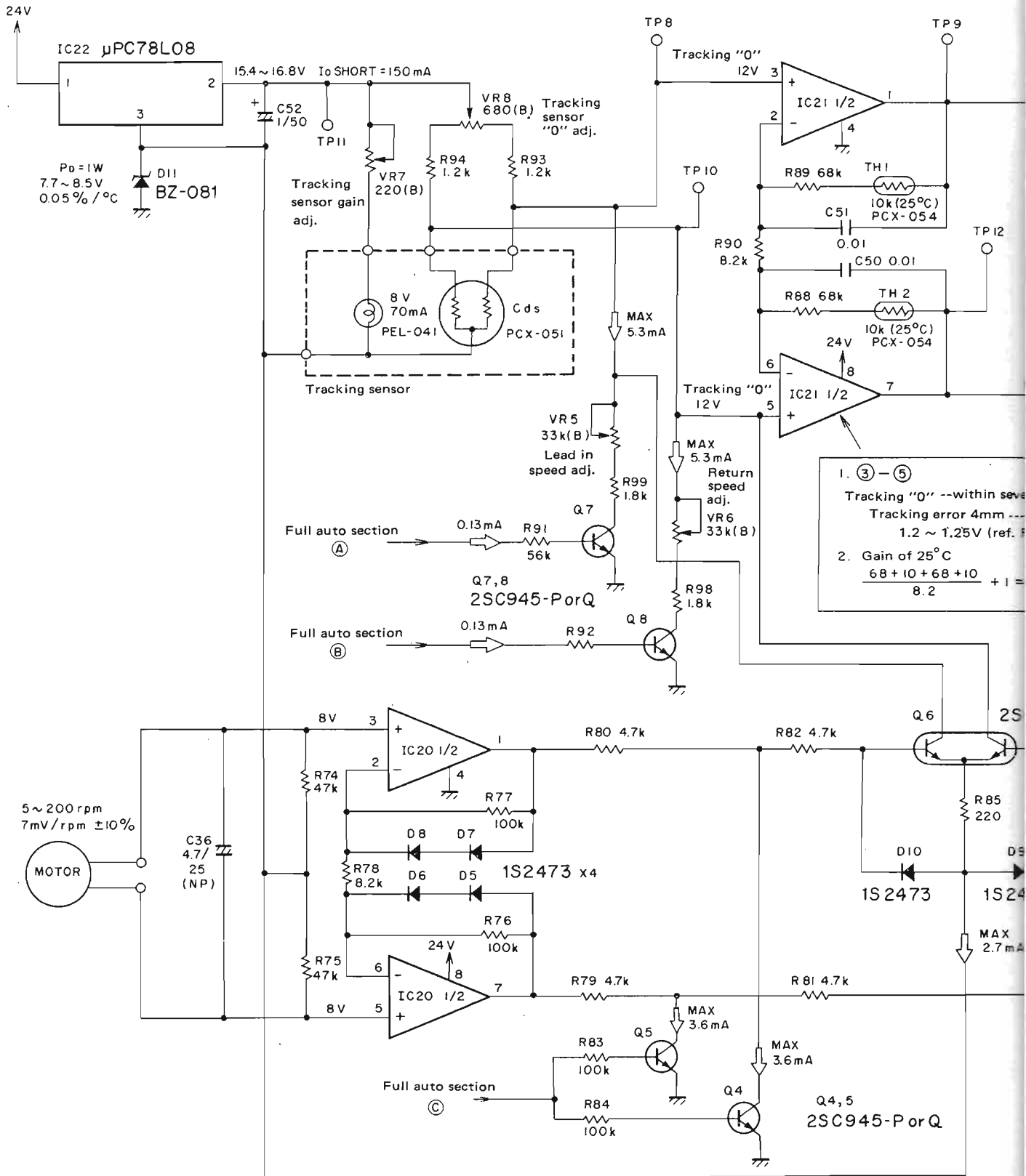

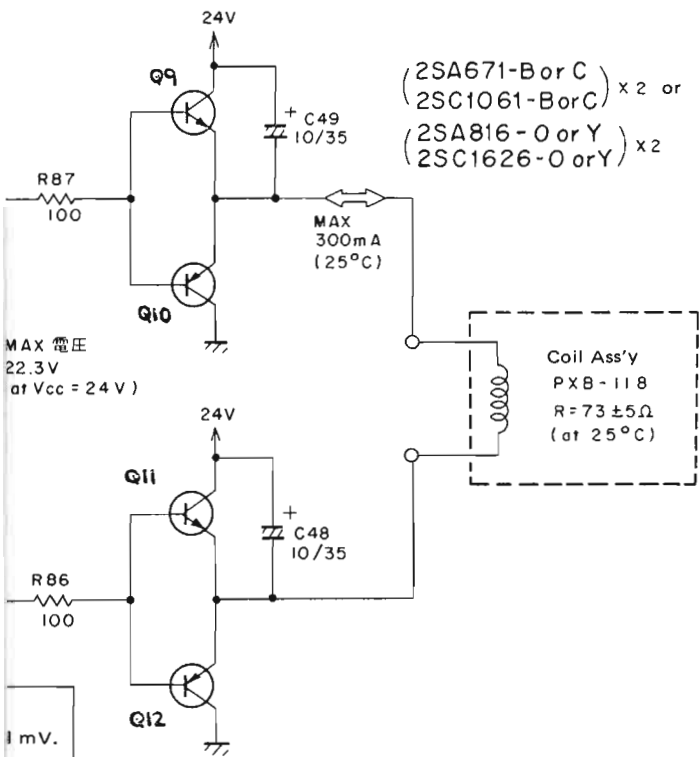

MAX 電圧
22.3V
at Vcc = 24V)

1 mV.
.6-4)
0.0

1583-F or G

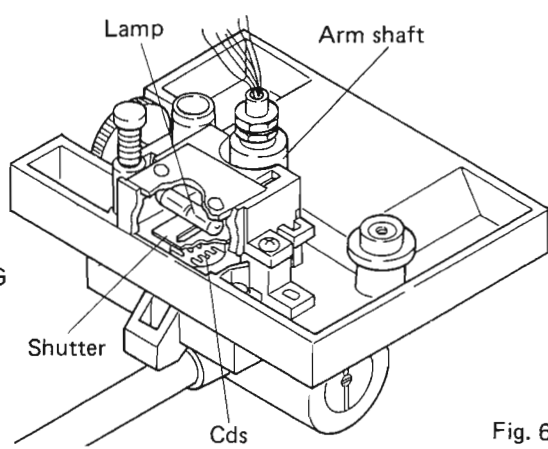

Fig. 6-3

3

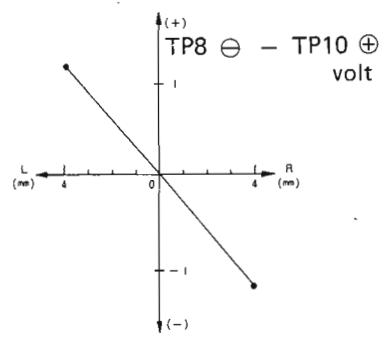

Fig. 6-4

7. ADJUSTMENTS

Adjustment position

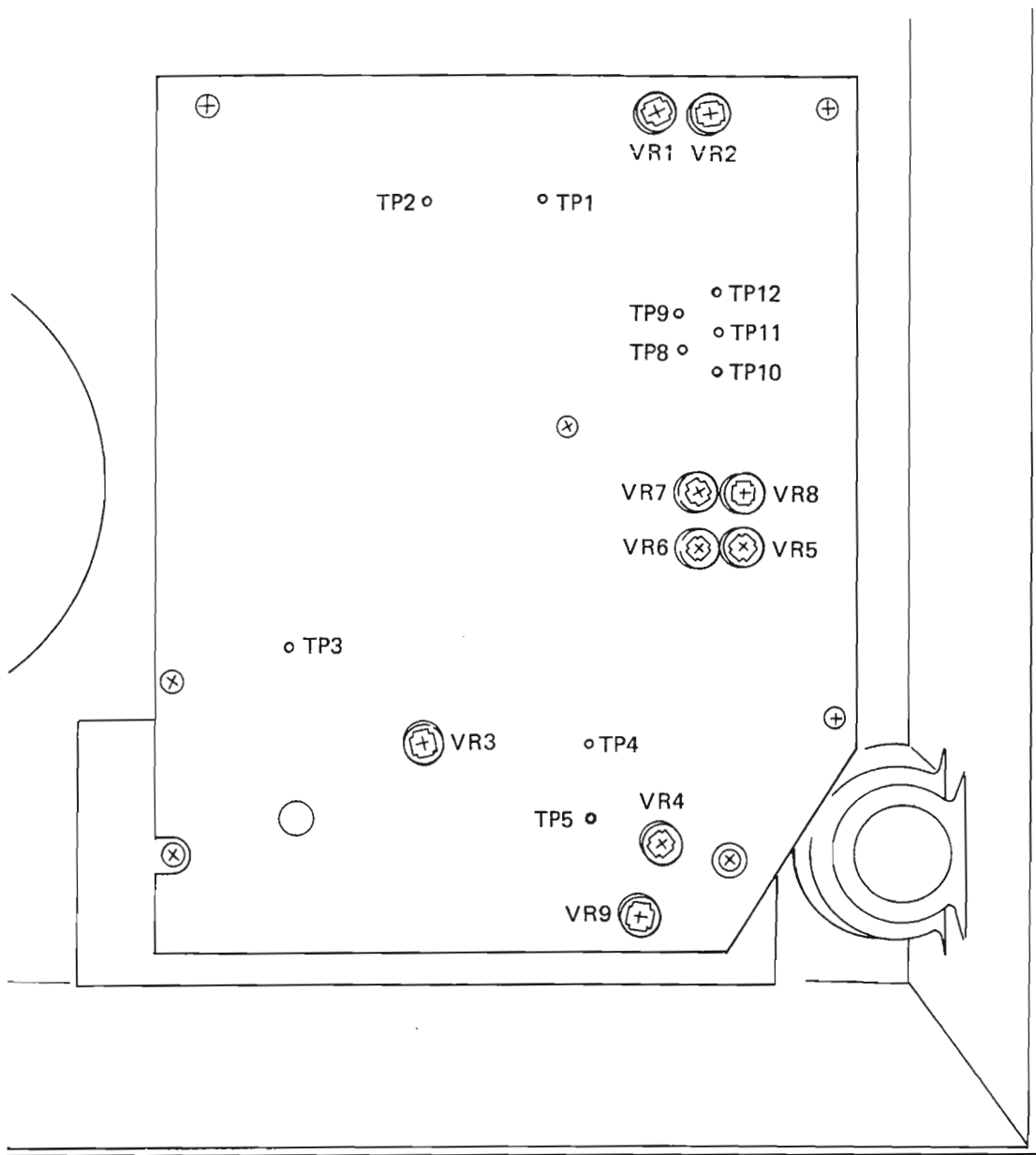

Fig. 7-1

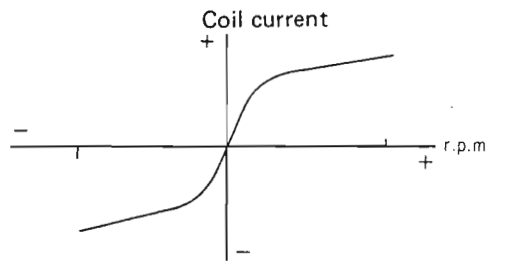

Fig. 6-5

7-0. ADJUSTMENTS

Preparation:

1. Disconnect the panel according to the disassembly method outlined in section 3-0.
2. Use extension leads to connect the panel to the printed circuit board located in the base section.
3. Remount the turntable platter (but without tightening the securing screws).

7.1 Direct Drive Motor Operating Point Adjustment

1. Connect the TP1 and TP2 terminals to the CH1 and CH2 inputs of a dual-trace oscilloscope.
2. Start the turntable platter turning by shifting the tonearm over towards the center of the record from the arm rest position.
3. Observe the waveforms in the oscilloscope, and adjust the corresponding controls so that the rising edge of the TP2 output waveform lies within the TP1 output waveform.
4. VR1 is the control to adjust for 45 RPM speed, while VR2 is the control for 33 1/3 RPM adjustment.

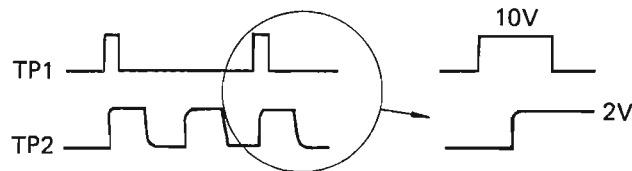

Fig. 7-2

7.2 Auto Lead-In Timing Adjustment

1. Set the record size selector to the 30cm position.
2. Press the START/STOP key to start the tonearm lead-in movement.
3. When the tonearm is about 20mm away from the outer edge of the record, an output pulse signal will appear at TP3 (see fig. 7-3). Adjust VR3 to obtain a time constant of 2.2 - 2.5 seconds for this pulse signal.

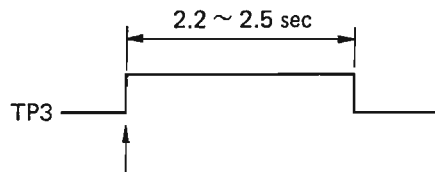

Fig. 7-3

7.3 End Sensor Sensitivity Adjustment

1. Connect the oscilloscope to the TP4 terminal.
2. Set the arm elevator to the UP position, and shift the tonearm across to near the lead-out groove.
3. Hold the tonearm carrier by hand, and move the tonearm back and forth at a rate of 5 to 10 cm/second.

4. During this operation, adjust VR9 so that the TP4 output saturates at H and L levels at about 50% duty.

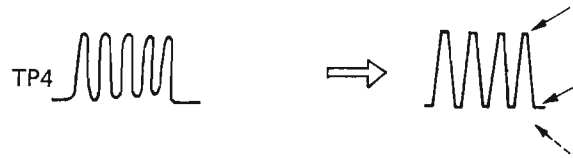

Fig. 7-4

7.4 End Timer Adjustment

1. Connect the oscilloscope to the TP5 terminal.
2. Secure the tonearm to the arm rest, and remove the turntable platter.
3. Insert a piece of paper (or any other light shield) into the and sensor stage.
4. As soon as the piece of paper (or light shield) is removed, an output signal appears at TP5. Adjust the time constant of this output to 1.06 ± 0.1 second by means of VR4.

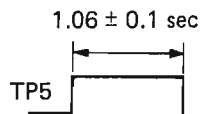
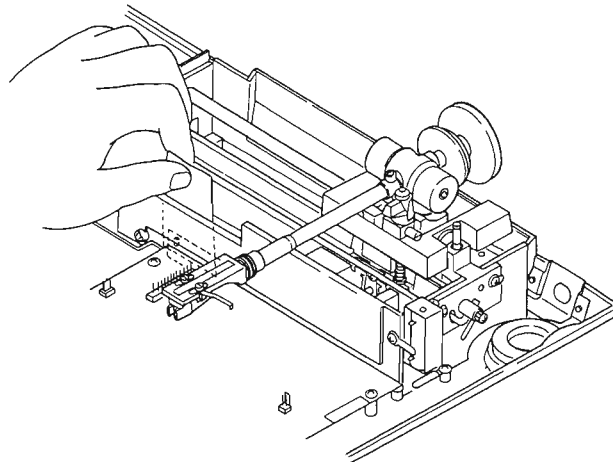

Fig. 7-5

7.5 Tracking Sensor Zero Point Adjustment

1. Set the arm elevator to the UP position, and adjust VR8 to obtain a voltage of less than ± 0.1 volt between TP9 (-) and TP12 (+).
2. Set the arm elevator to the UP and DOWN positions repeatedly, and also perform each of the automatic mode operations. Finally set the arm elevator back to the UP position, and check that the voltage across the TP9 and TP12 terminals remains below ± 0.35 V.

7.6 Tracking Sensor Gain Adjustment

1. Disconnect the drive coil connector, and insert a piece of paper (or any other light shield) into the rest sensor stage and stop the direct drive motor rotation.

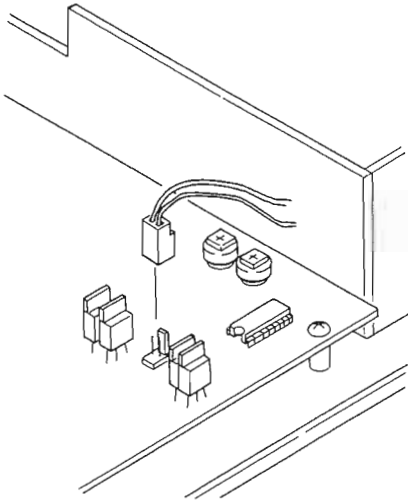

Fig. 7-6

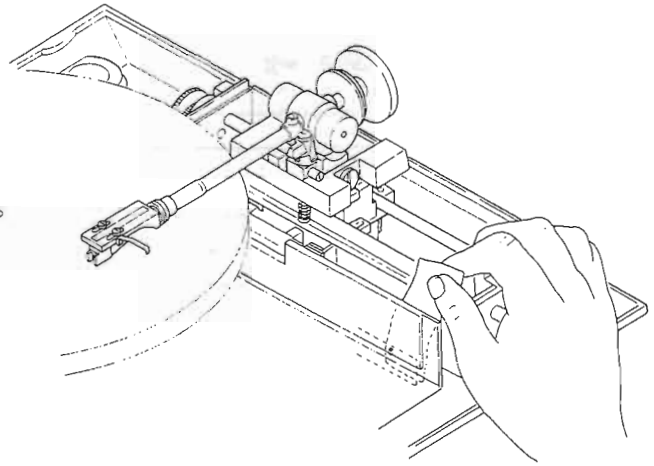

Fig. 7-7

2. Shift the tonearm across to any desired position above the turntable platter, and then fix the rail and roller to secure the carrier.
3. With the arm elevator in the DOWN position, shift the tonearm across to a position 4mm to the left of the tonearm center position.
4. Then adjust VR7 so as to obtain a voltage of 1.2 to 1.25V across the TP8 and TP10 terminals.
5. Next shift the tonearm to a position 4mm to the right of the tonearm center, and check that the voltage across TP8 and TP10 varies by no more than $\pm 0.15V$ from the value measured in step 4 above.

NOTES: * Because of the "ghost" tendency caused by light from the tracking sensor lamp (as shown in fig. 7-8), this adjustment must be performed with care.
* Perform the above tracking sensor adjustment procedures (7.5 and 7.6) at least twice.

7.7 Lead-In and Return Speed Adjustment

1. Set the record size selector to the 17cm position.
2. Press the START/STOP key to commence the tonearm lead-in operation.
3. Adjust VR5 so that the time required to reach the 17cm position is 5.5 to 6.5 seconds.
4. Then adjust VR6 so that the time required for the tonearm to return to rest from the 17cm position is also 5.5 to 6.5 seconds.

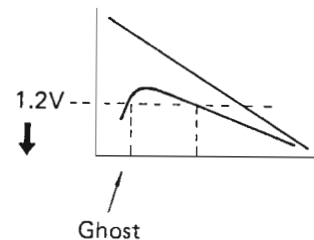
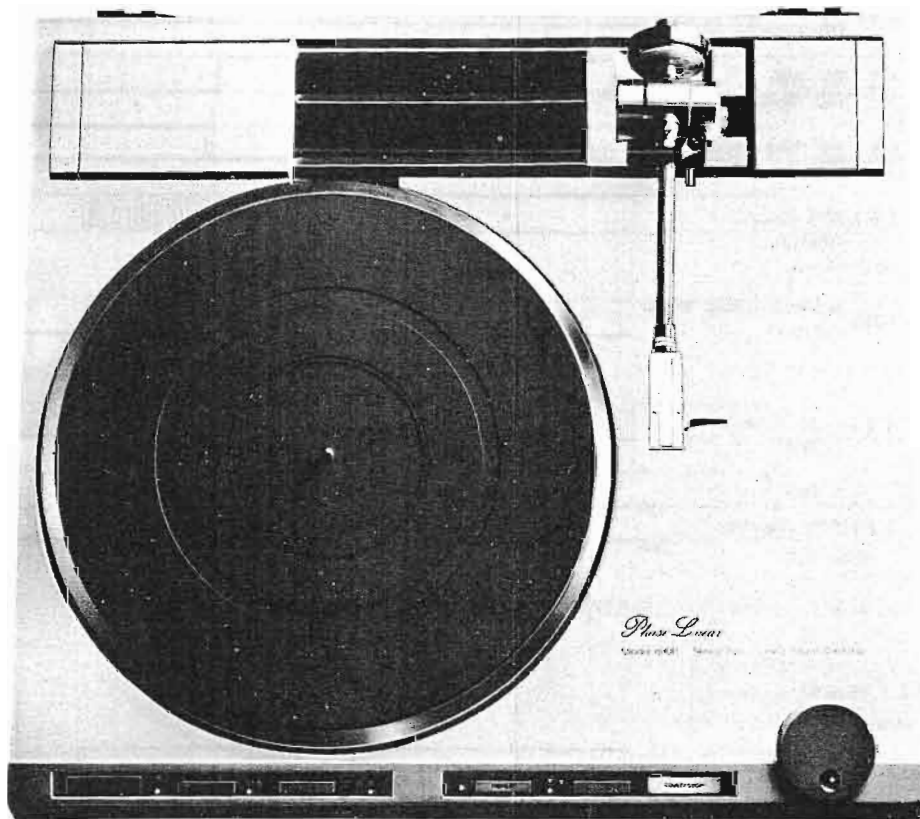

Fig. 7-8



8. TIMING CHART

3 Invar
rest 81

(1) LEAD IN PLAY

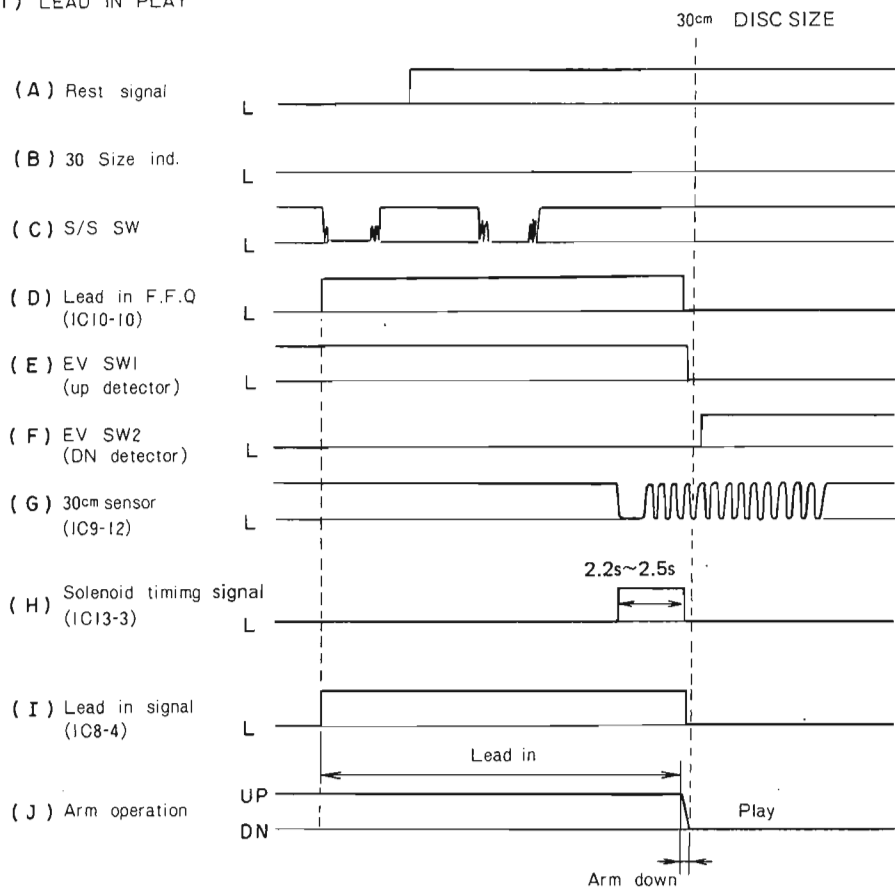

(3) REPEAT

- (A) Rest signal
- (B) 30 size ind.
- (C) 30cm sensor (IC9-12)
- (D) End sensor
- (E) End detector signal (IC14-4)
- (F) Return F.F.Q (IC9-6)
- (G) EV SW1 (up detector)
- (H) EV SW2 (DN detector)
- (I) Repeat ind.
- (J) Solenoid timing signal (IC13-3)
- (K) Arm operation

(2) REJECT

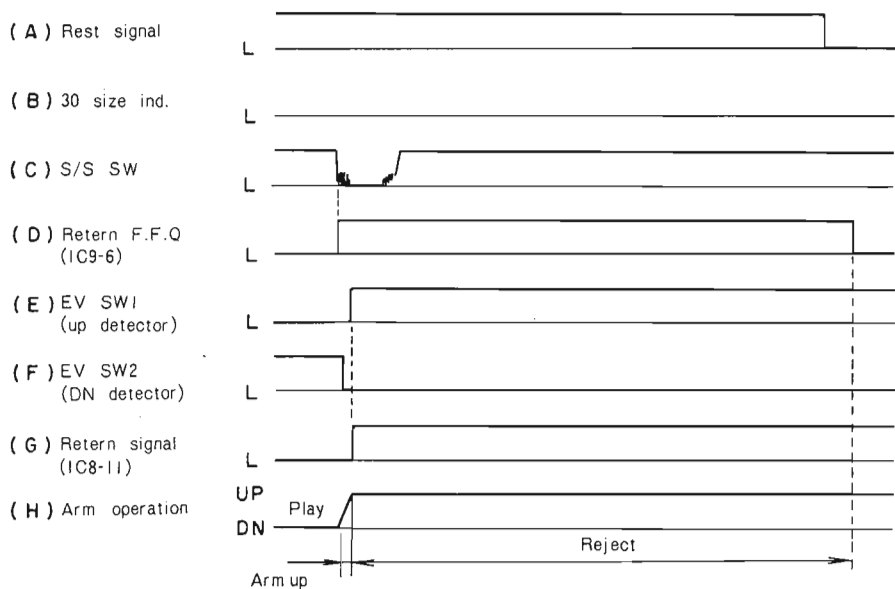

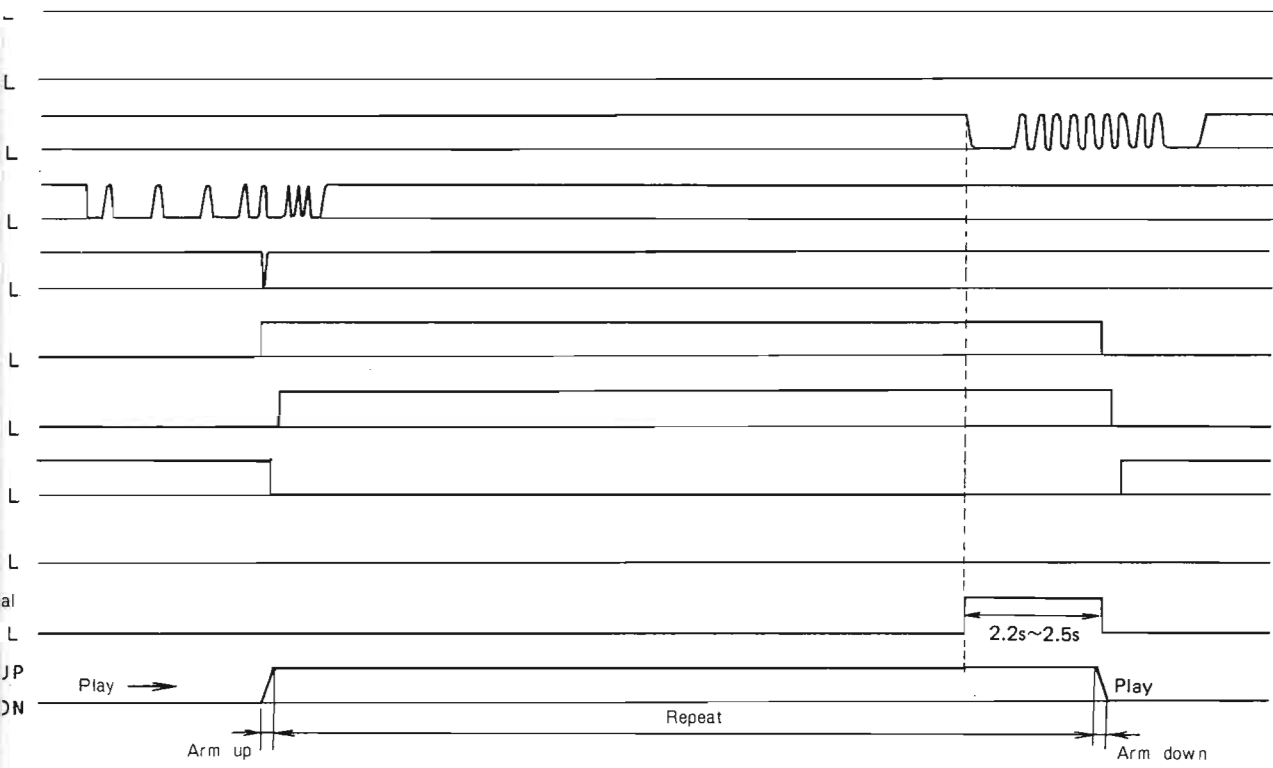

- NOTES :
- UP — Arm elevation UP
 - DN — Arm elevation DOWN
 - S/S — START-STOP Switch
 - F.F — FLip Flop
 - EV — Elevation (Tonearm)

9. TROUBLE SHOOTING

9.1 CIRCUIT BLOCK

9.1.1

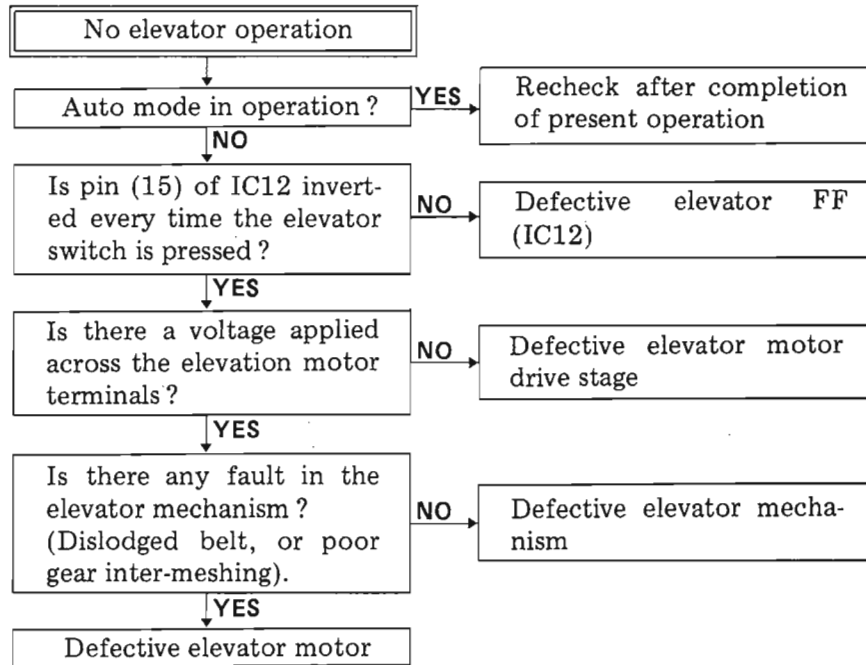

9.1.2

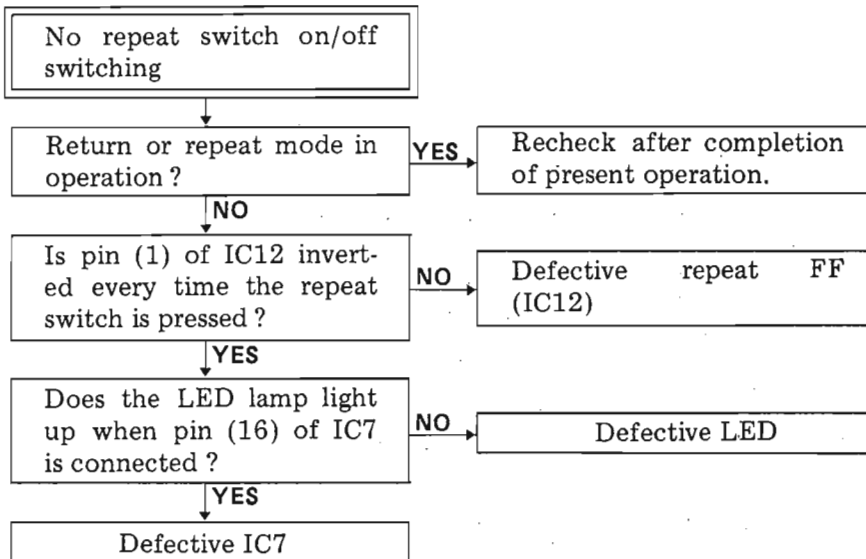

9.1.3

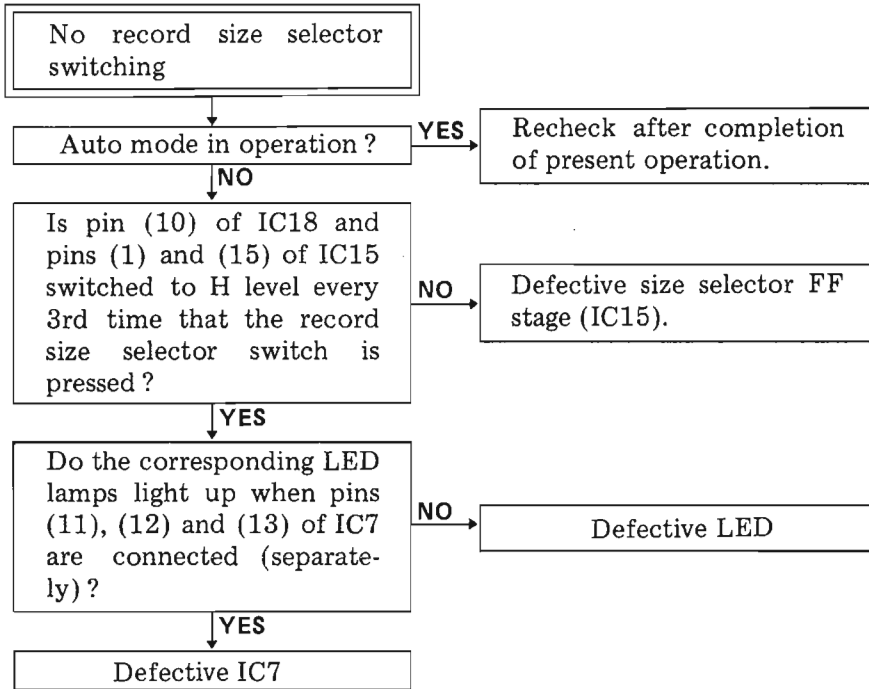

9.1.4

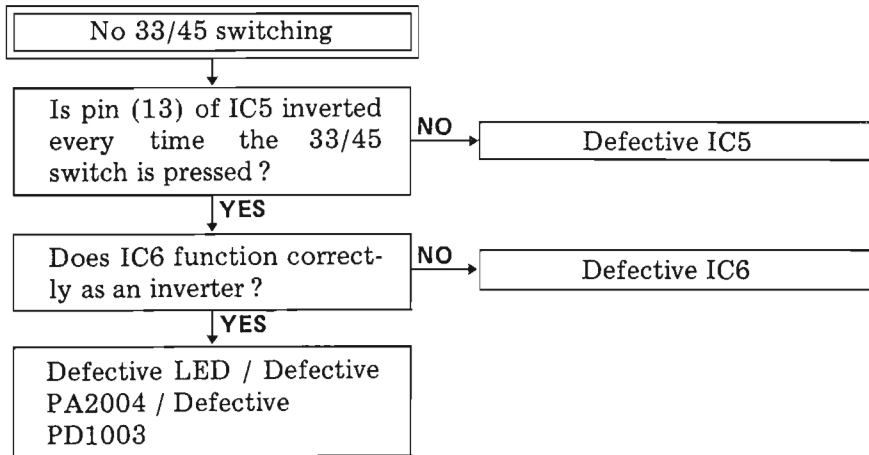

9.1.5

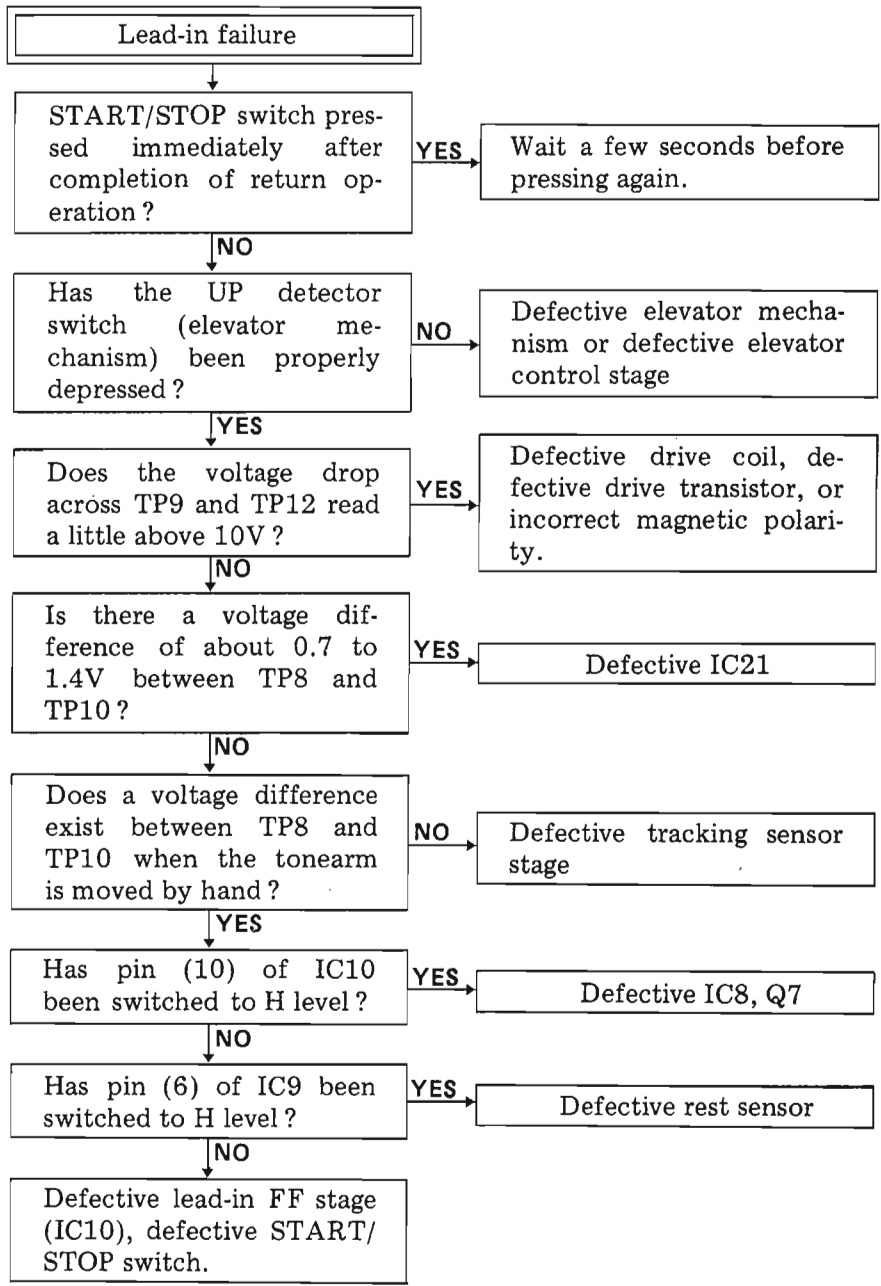

9.1.6

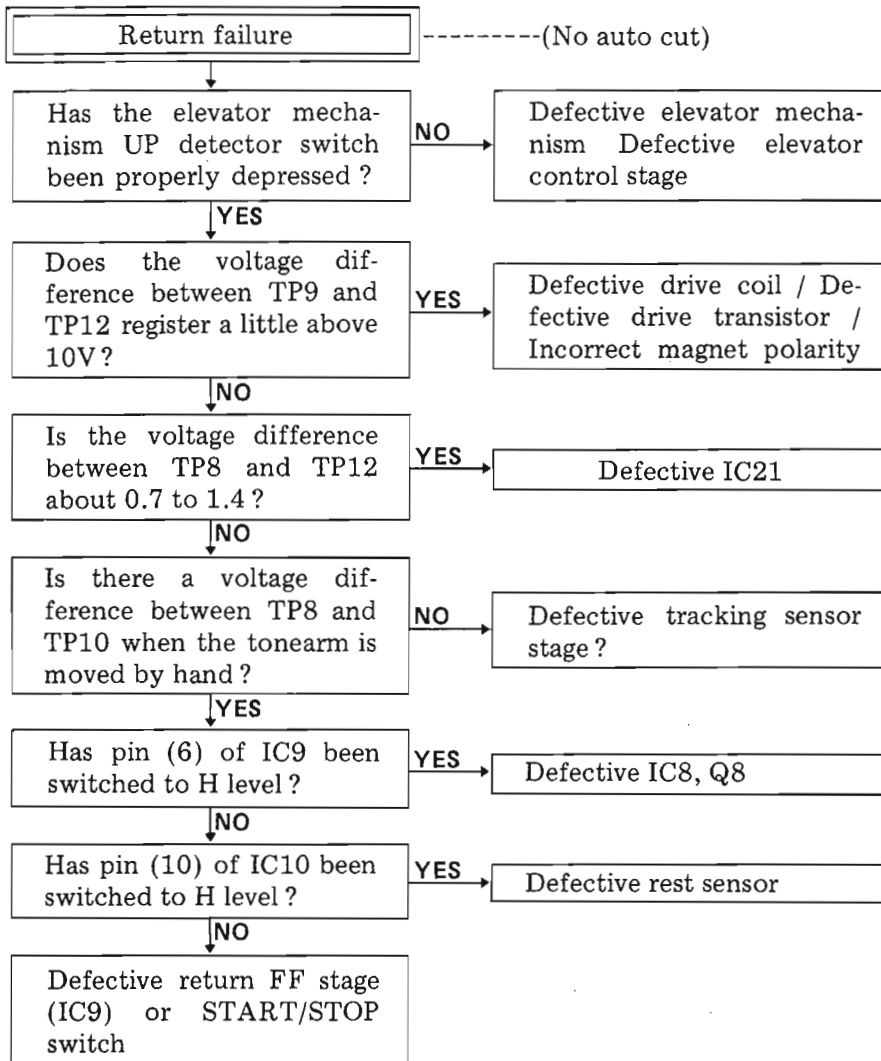

9.1.7

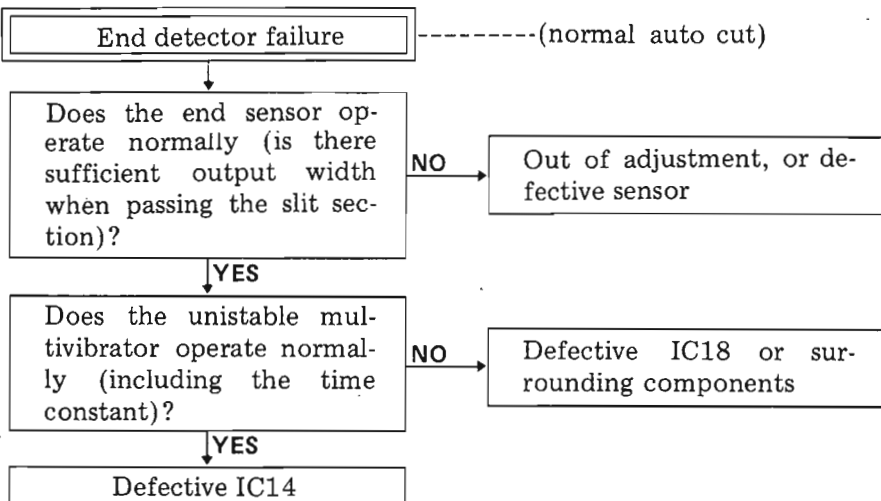

9.1.8

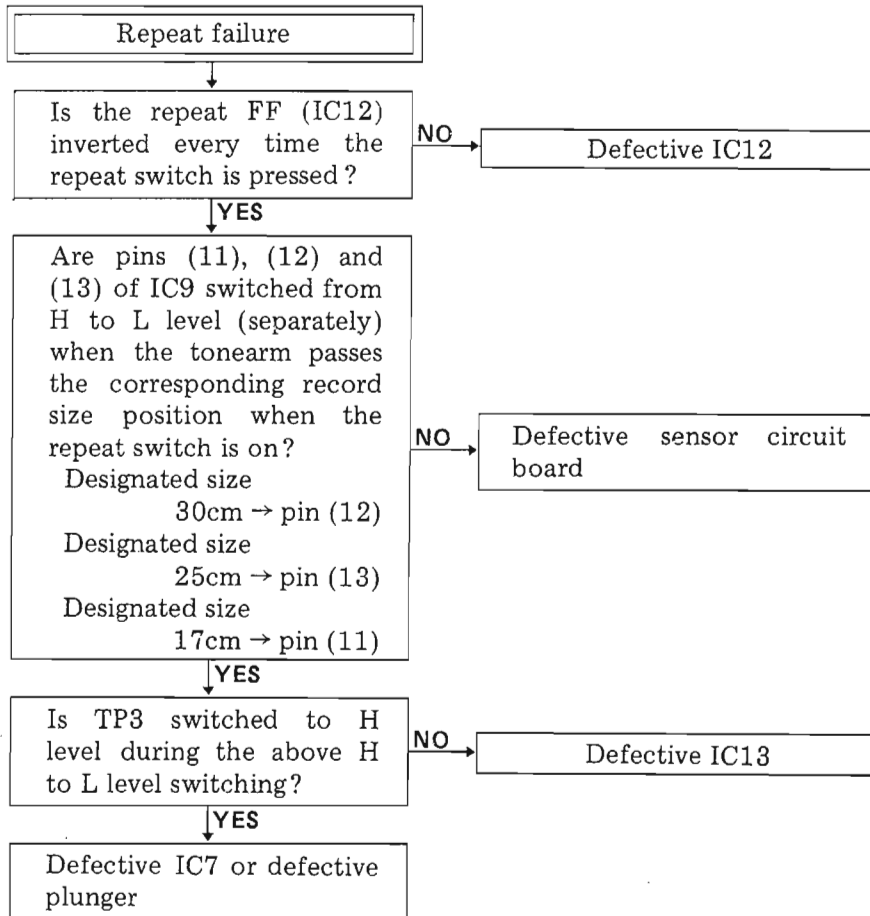

9.1.9

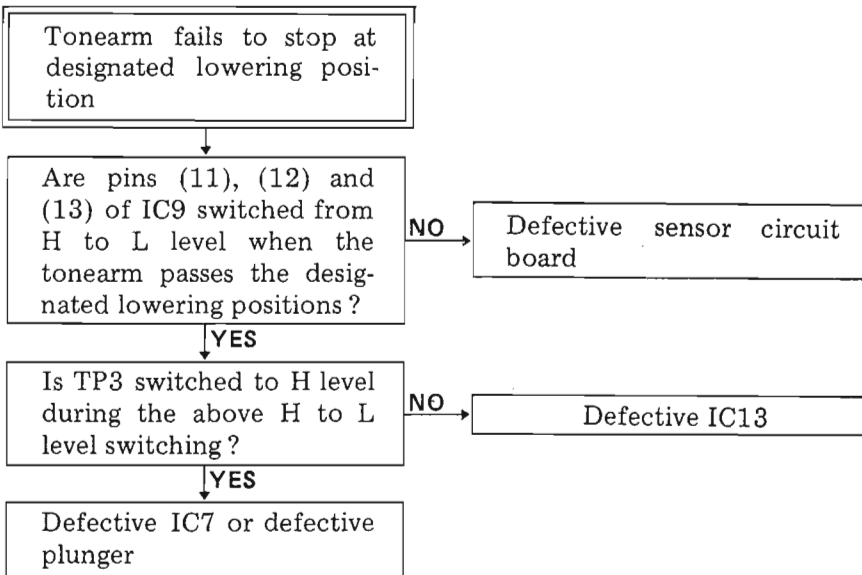

9.1.10

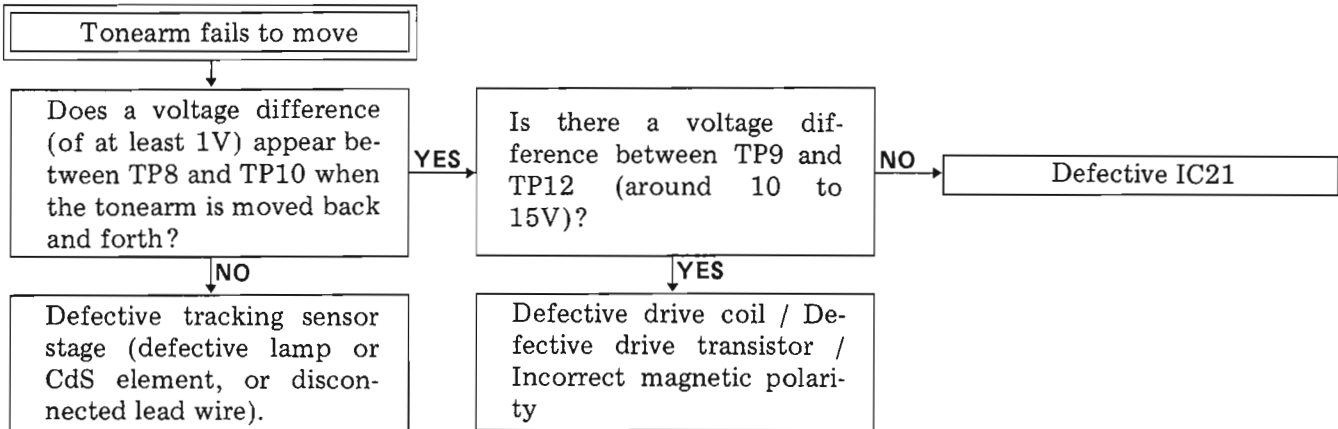

9.1.11

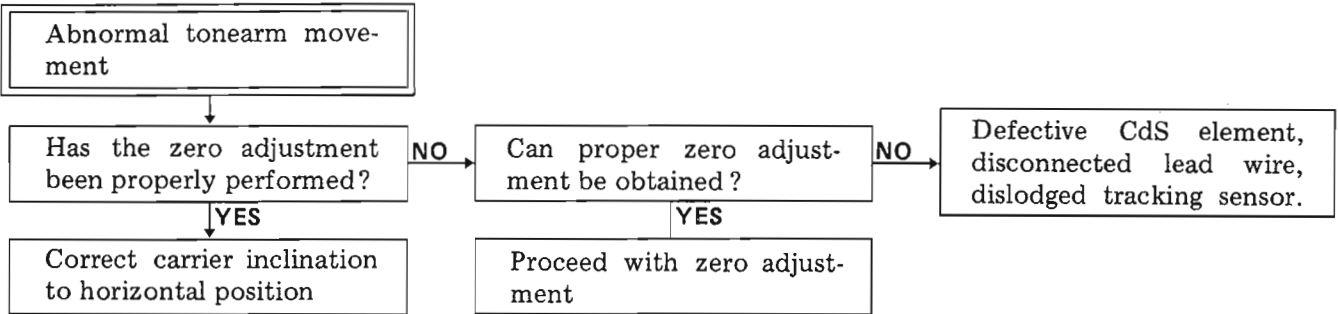

9.1.12

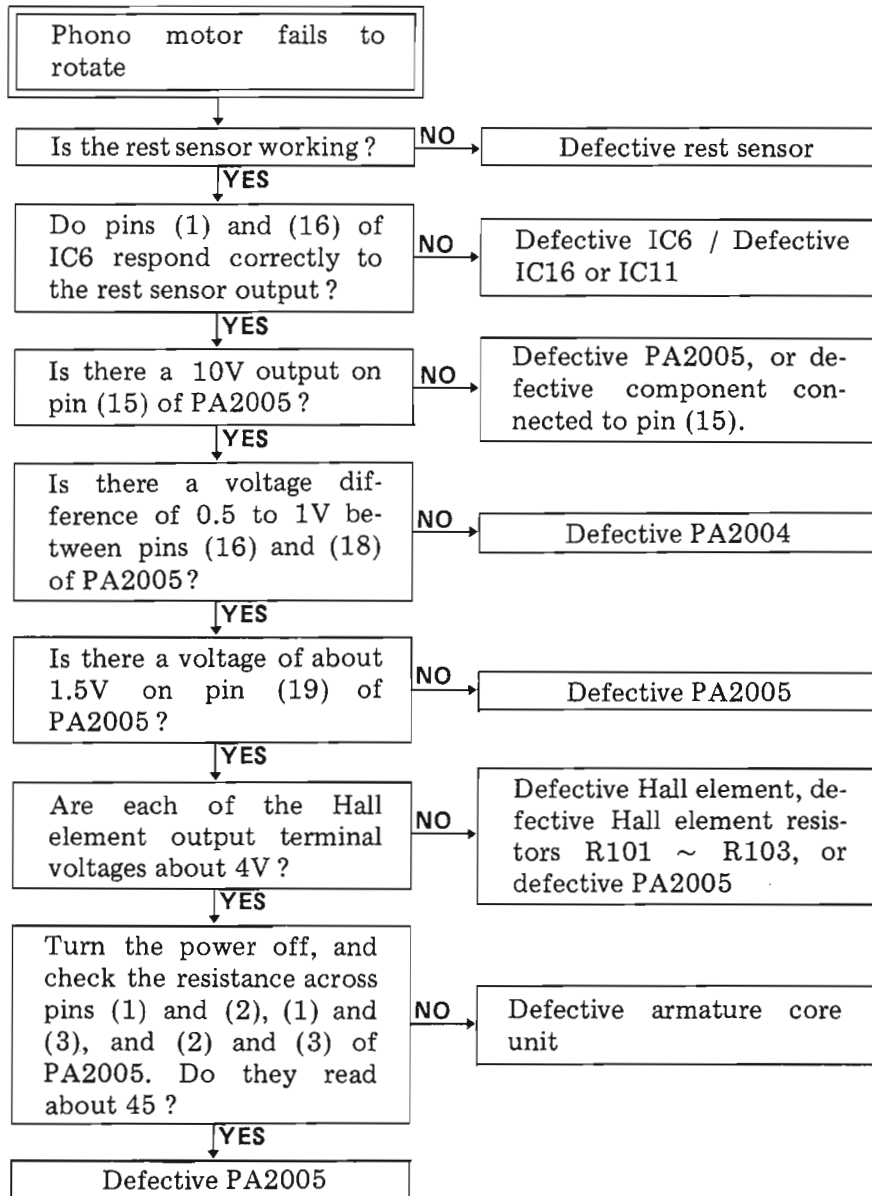

9.1.13

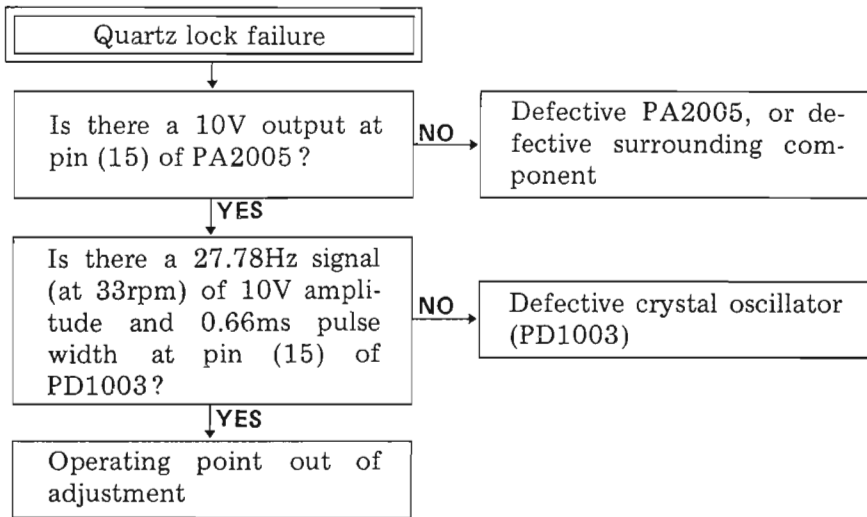

9.1.14

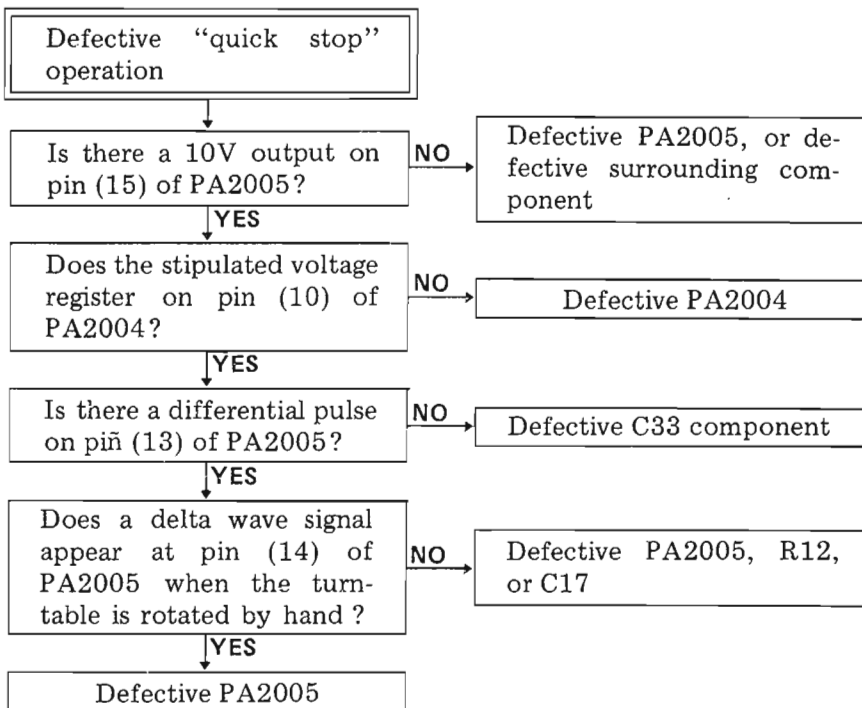

9.1.15

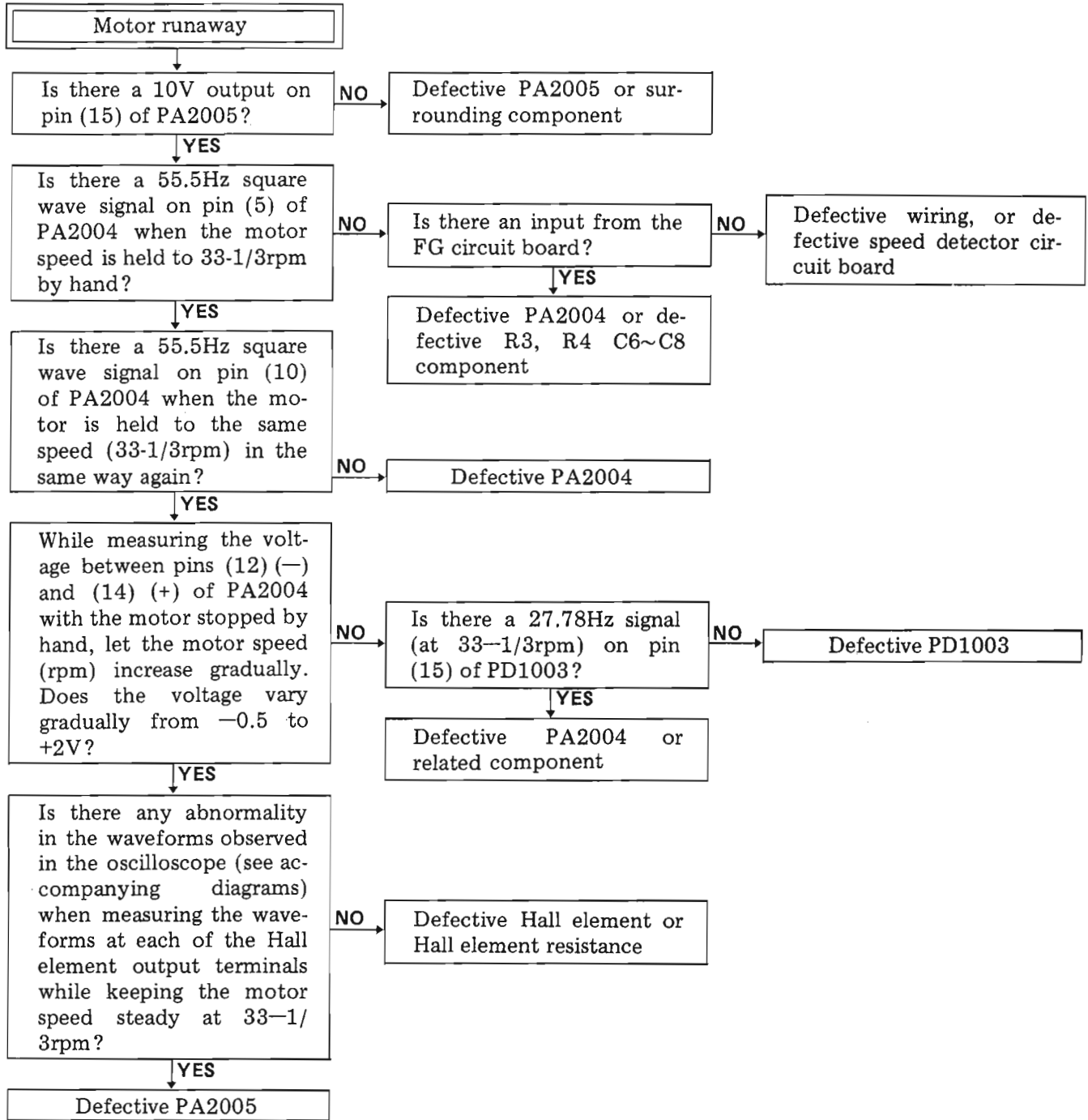

[Hall element output waveforms]

A. Normal waveform

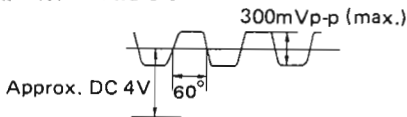

B. Low output waveform (AC output)

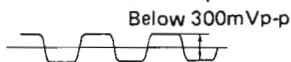

C. Examples of distorted waveform (but normal output level)

Ex. 1

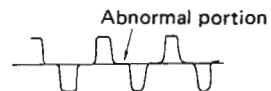

Ex. 2

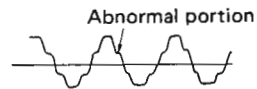

9.2 MECHANISM BLOCK

9.2.1

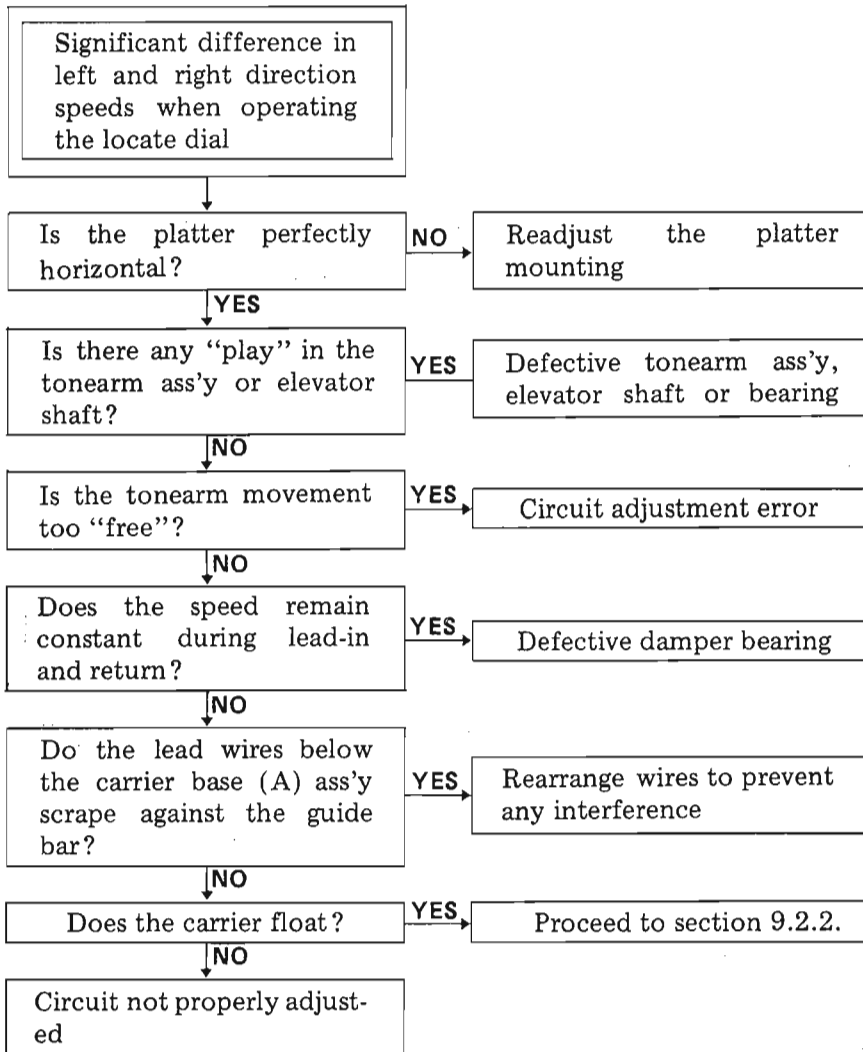

9.2.2

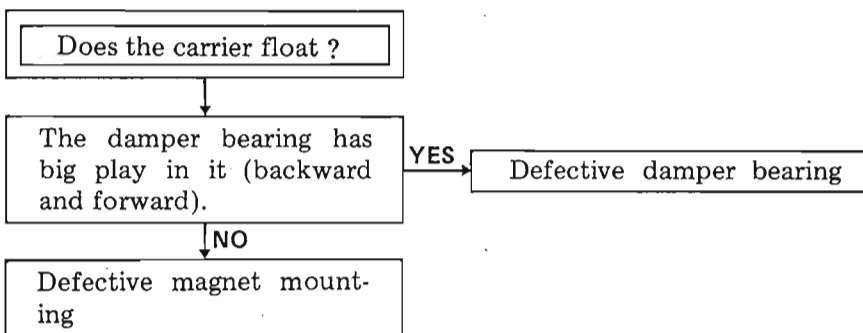

9.2.3

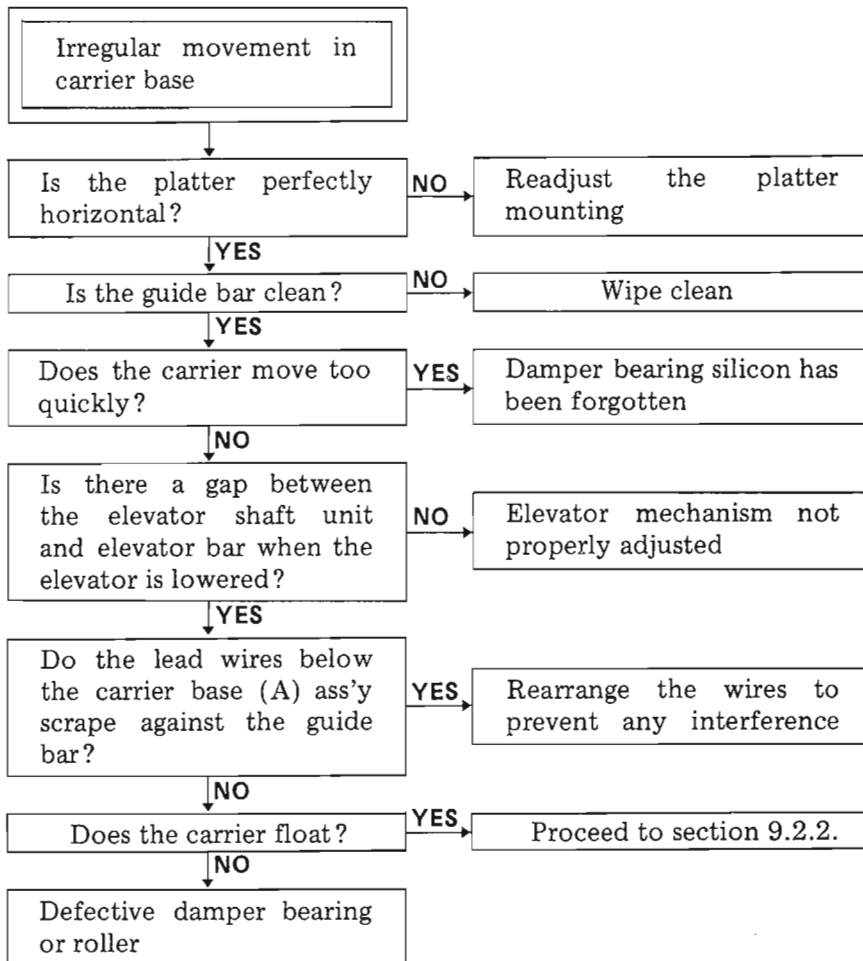

9.2.4

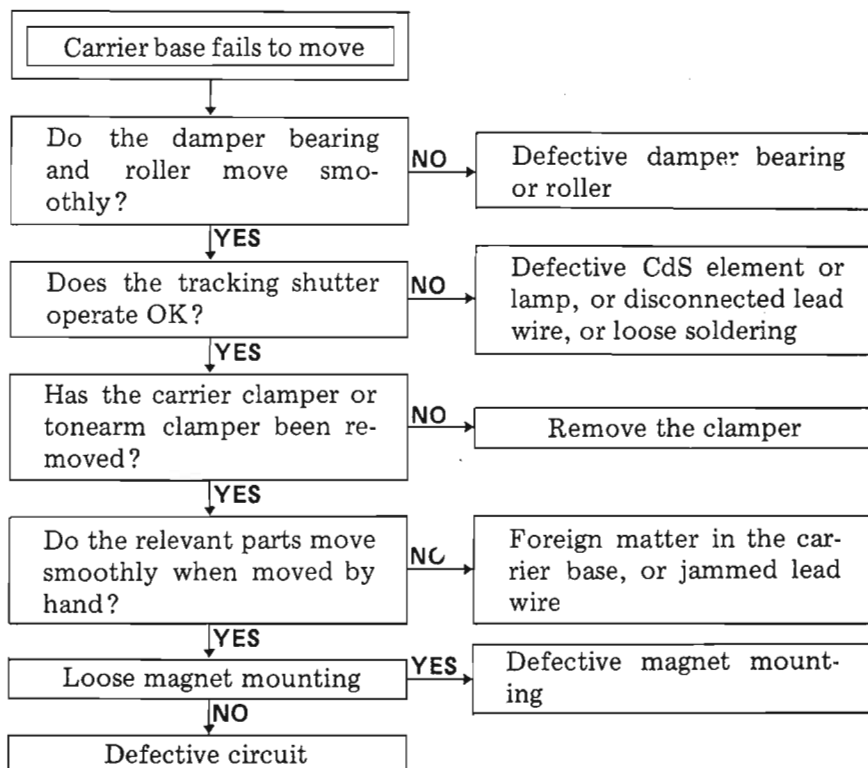

9.2.5

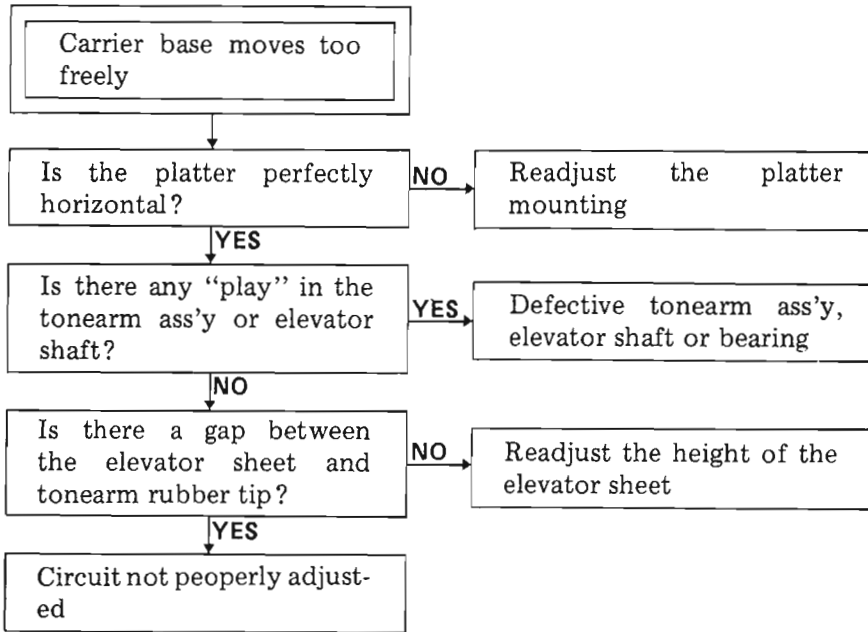

9.2.6

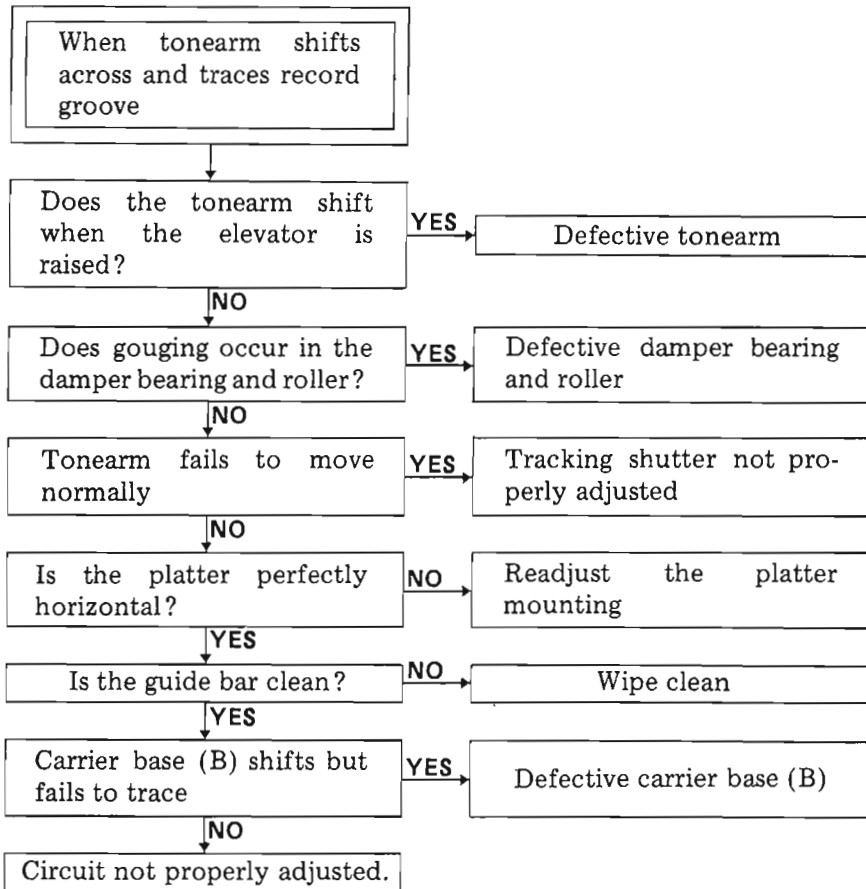

9.2.7

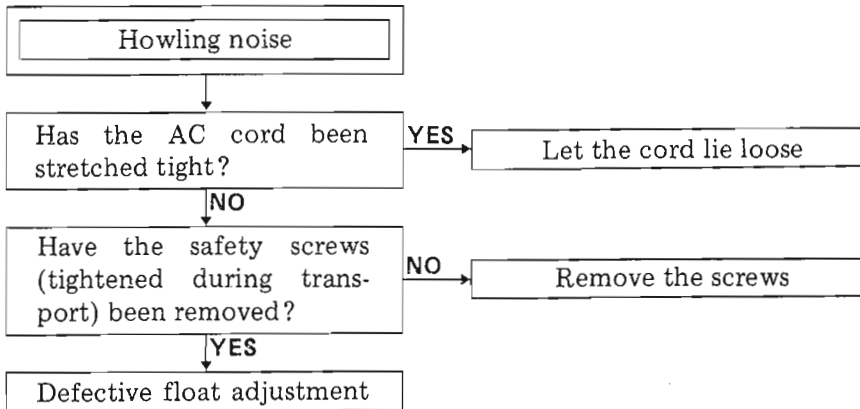

9.2.8

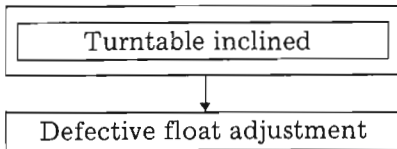

9.2.9

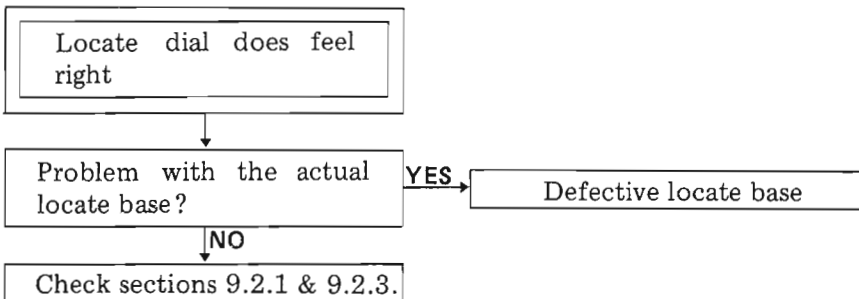

9.2.10

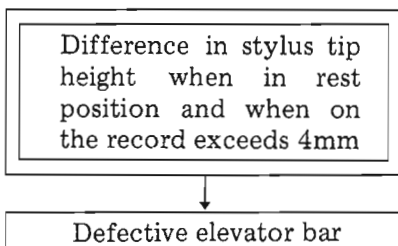

9.2.11

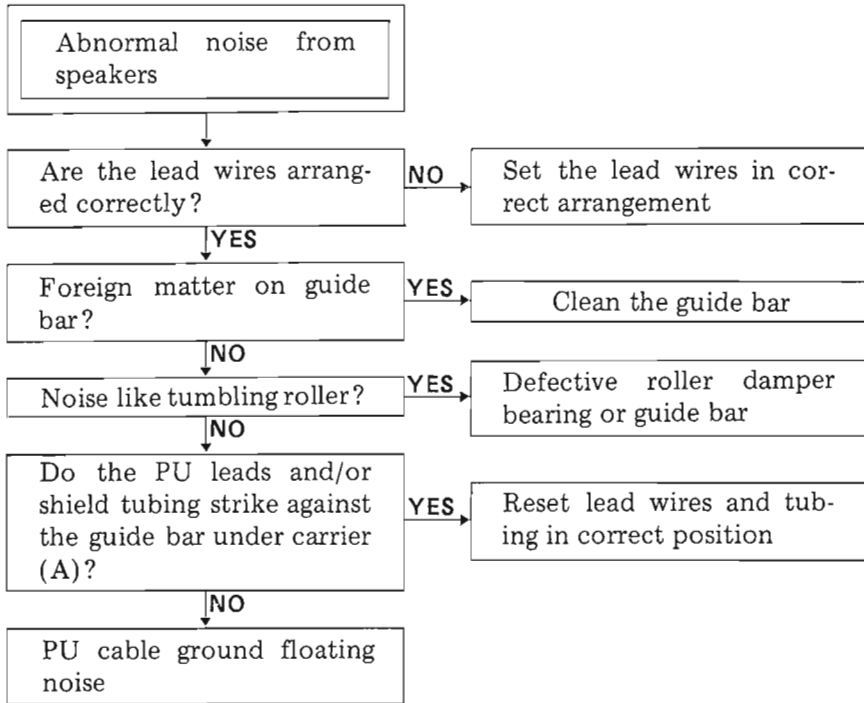

9.2.12

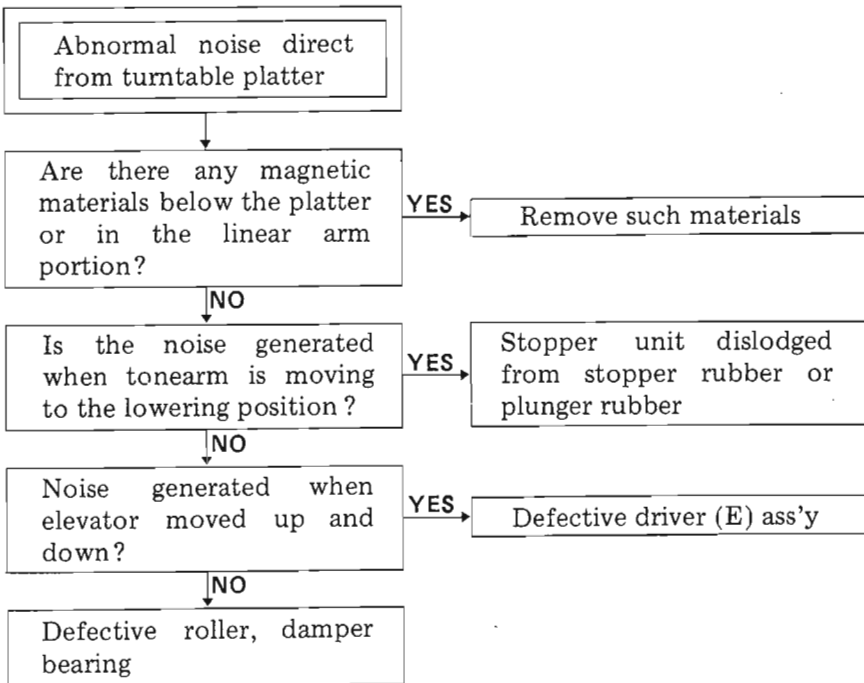

9.2.13

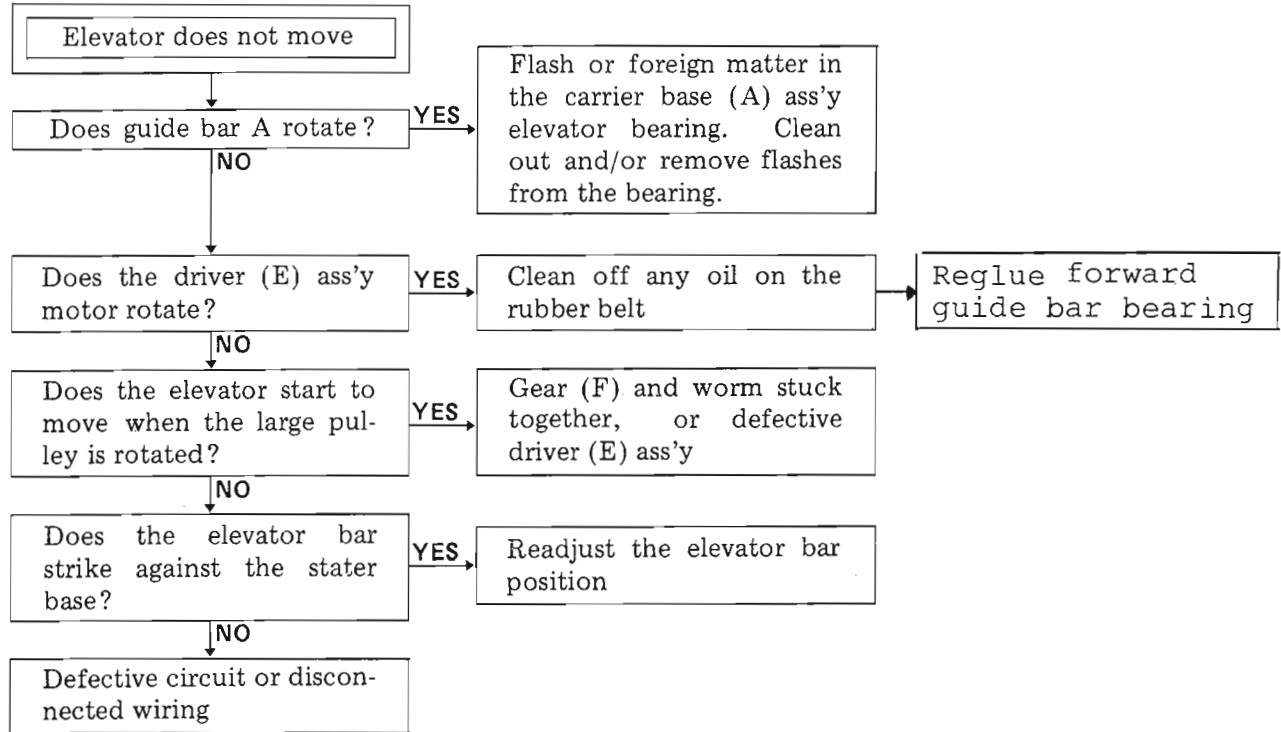

9.2.14

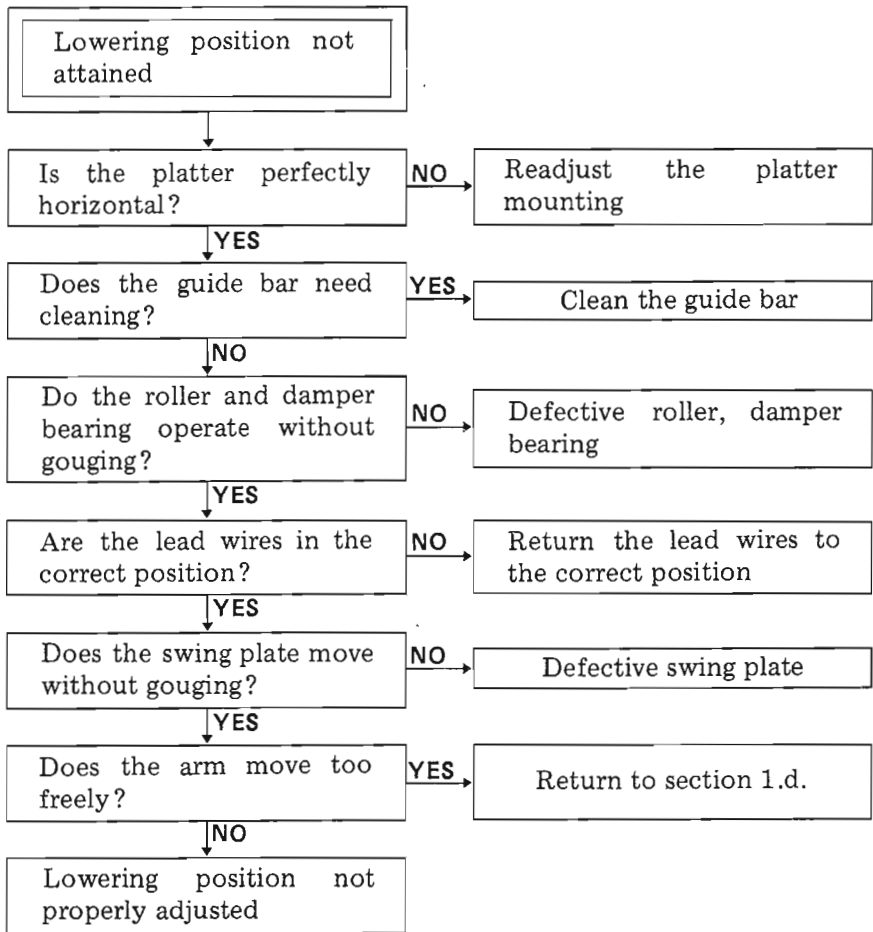

9.2.15

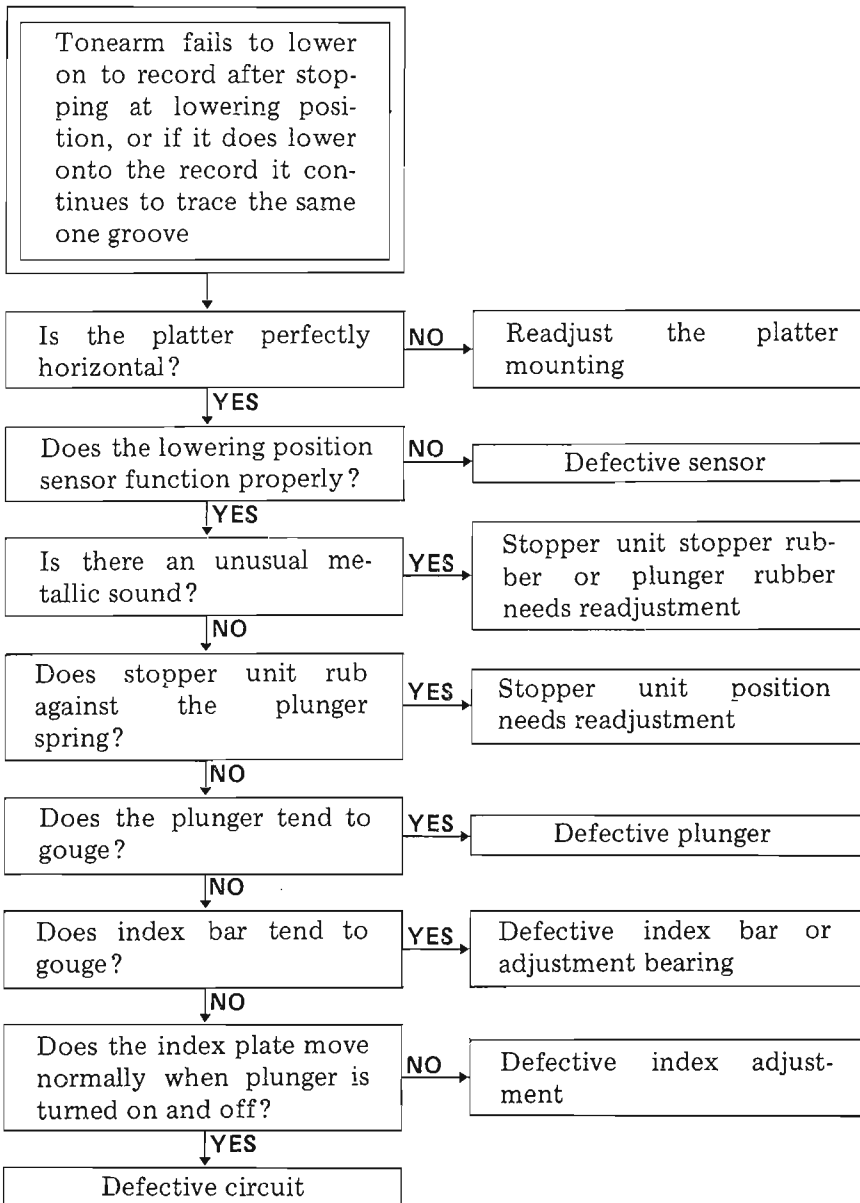

9.2.16

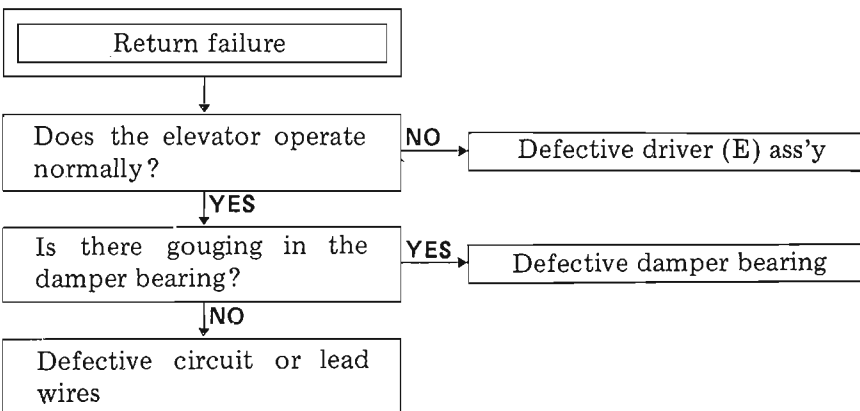

10. EXPLODED VIEWS

	P.
10.1 Exterior	53
10.2 Bottom (Base) Plate	56
10.3 Tonearm Assembly	59
10.4 Elevation Mechanism	61

NOTES

10. EXPLODED VIEWS

10.1 EXTERIOR

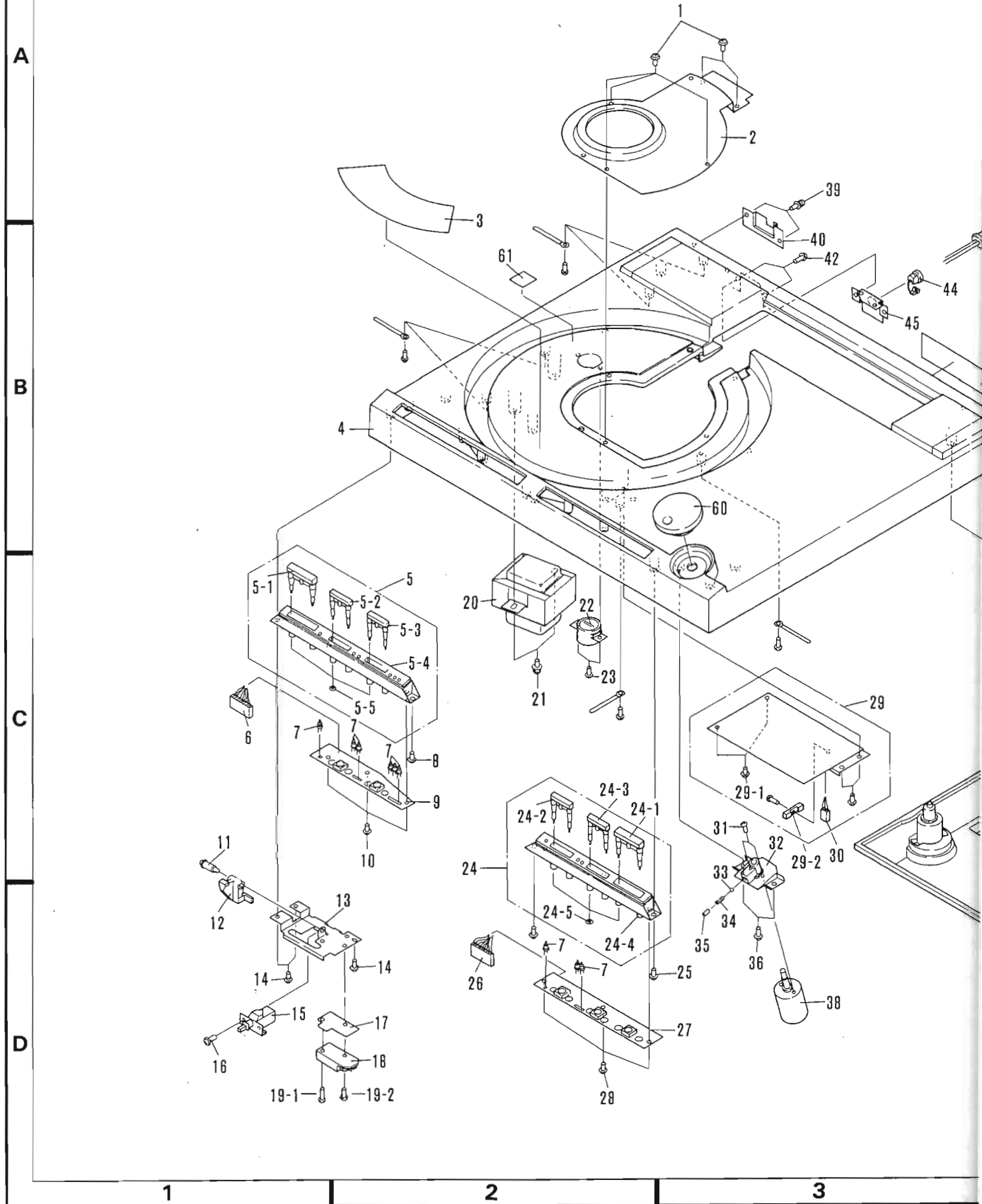

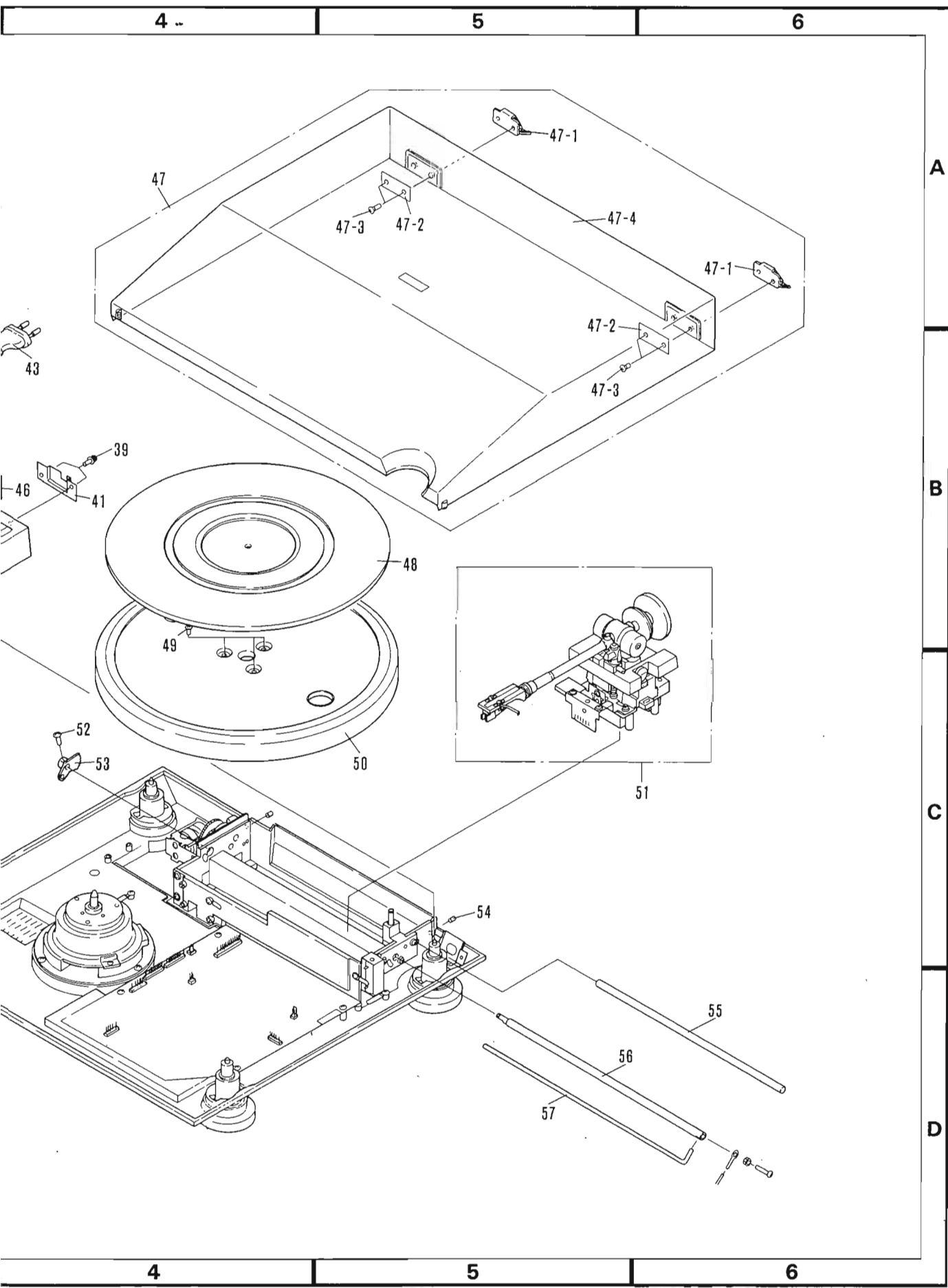

Parts List of Exterior

NOTES: * The \triangle mark found on some component parts indicates the importance of the safety factor of the part. Therefore, when replacing, be sure to use parts of identical designation.

* Parts without part numbers CANNOT be supplied.

Key No.	Part No.	Description	Key No.	Part No.	Description
1.	922-8054	Washer faced alutite screw:3 x 8	30.	924-8023	Connector harness
2.		Cover	31.	922-8061	Screw:PSA2.6 x 6
3.		Caution label	32.	942-8035	Base
4.	942-8087	Panel	33.	942-8060	Nylon ball 3 ϕ
5.	930-8028	Control case assy.	34.	921-8027	Spring
5-1.	942-8075	Pushbutton unit A	35.	922-8060	Setscrew:SF4 x 5
5-2.	942-8076	Pushbutton unit E	36.	922-8054	Washer faced alutite screw:3 x 8
5-3.	942-8077	Pushbutton unit C	37.		
5-4.	942-8081	Control case A	38.	929-8018	Motor
5-5.	922-8055	CS type washer:2 ϕ	39.	922-8054	Washer faced alutite screw:3 x 8
6.	924-8020	Connector harness	40.	942-8066	Plate:L
7.	926-8101	LED:GL-2PR1	41.	942-8068	Plate:R
8.	922-8054	Washer faced alutite screw:3 x 8	42.	922-8062	Screw:PSB3 x 8
9.		PC board \triangle	43.	921-8017	Line cord
10.	922-8056	Screw:PT3 x 8	44.	921-8056	Strain relief
11.	922-8035	Screw	45.		Angle
12.	942-8042	Lever	46.		Label
13.		Switch base	47-1.	930-8030	Hinge assy.
14.	922-8054	Washer faced alutite screw:3 x 8	47-2.	941-8001	Plate
15.	929-8016	Push switch	47-3.	922-8063	Screw
16.	922-8059	Washer faced alutite screw:3 x 6	47-4.	942-8059	Dust cover
\triangle 17.	941-8014	Insulator	48.	942-8073	Rubber mat
\triangle 18.	929-8023	Microswitch	49.	922-8046	Screw
19-1.	922-8057	Screw:PSA3 x 15	50.	943-8012	Turntable platter
19-2.	922-8058	Plastic screw:3 x 15	51.		
\triangle 20.	925-8029	Power transformer	52.	922-8064	Screw:PM3 x 8
21.	922-8041	Screw:PSB4 x 8	53.	942-8046	EV gear
22.			54.		
23.	922-8054	Washer faced alutite screw:3 x 8	55.	943-8008	Guide bar:B
24-1.	942-8078	Pushbutton unit B	56.	943-8007	Guide bar:A
24-2.	942-8079	Pushbutton unit D	57.	921-8014	EV bar
24-3.	942-8080	Pushbutton unit F	58.		
24-4.	942-8082	Control case B	59.		
24-5.	922-8055	CS type washer 2 ϕ	60.	942-8055	Dial knob
25.	922-8054	Washer faced alutite screw:3 x 8	61.		Label
26.	924-8019	Connector harness			
27.		PC board			
28.	922-8056	Screw:PT3 x 8			
\triangle 29.	901-8002	Power supply PCB			

Parts List of Bottom Plate

NOTE: *Parts without part numbers CANNOT be supplied.

Key			Key		
No.	Part No.	Description	No.	Part No.	Description
1.	922-8083	Screw:PSA4 x 16	41.		Case
2.	929-8021	Motor assy.	42.	922-8054	Washer faced alutite screw:3 x 8
3.	922-8072	Screw:PSB4 x 16	43.	924-8022	Connector harness
4.		Ballast weight	44.	901-8003	PCB:LED sensor
5.	922-8071	Screw:PT3 x 12	45.	922-8056	Screw:PT3 x 8
6.	941-8023	Cord clamper	46.	930-8027	Base clamp assy.
7.	942-8093	Chassis base	47.	929-8012	Solenoid assy.
8.	942-8040	Rubber cushion A	48.	922-8075	Setscrew:SF3 x 5
9.	921-8040	Spring C	49.	922-8067	Washer faced alutite screw:3 x 6
10.	942-8063	Spring holder	50.	943-8007	Guide bar:A
11.	942-8064	Case C	51.	943-8008	Guide bar:B
12.	922-8026	Screw	52.	921-8014	EV bar
13.	942-8072	Case unit (foot)	53.	922-8076	Hex nut:3mm
14.	922-8070	Screw:PM3 x 5	54.	922-8084	Screw:PM3 x 12
15.	942-8046	EV gear	55.	942-8041	Stopper cushion
16.		EV mechanism assy.	56.	922-8027	Screw
17.	922-8069	Circlip:EW6	57.	930-8033	Stopper unit
18.	922-8049	Circlip:EW3	58.	922-8077	Setscrew:HF3 x 3
19.	922-8072	Screw:PSB4 x 16	59.	921-8060	Tube
20.	922-8073	Index shaft adjuster	60.	921-8031	Spring
21.			61.		
22.	922-8074	Screw:PSB4 x 12	62.	921-8053	Output cord
23.	922-8075	Setscrew:SF3 x 5	63.	921-8005	Strain relief
24.		Base B	64.	941-8024	Bracket:str.relief
25.		Plate	65.	922-8071	Screw:PT3 x 12
26.	942-8094	Coil cover	66.	901-8012	PCB:control
27.	925-8030	Coil assy.	67.	922-8071	Screw:PT3 x 12
28.		Plate	68.	922-8056	Screw:PT3 x 8
29.		Plate	69.		
30.		Bar	70.		
31.					
32.	922-8003	Screw:PSF3 x 6			
33.	922-8056	Screw:PT3 x 8			
34.	901-8017	PCB:phototransistor			
35.	922-8074	Screw:PSB4 x 12			
36-1.	922-8012	Screw:PM2.6 x 6			
36-2.	922-8078	Screw:PM2.6 x 8			
37.		Base A			
38.	922-8075	Setscrew:SF3 x 5			
39.					
40.	922-8072	Screw:PSB4 x 16			

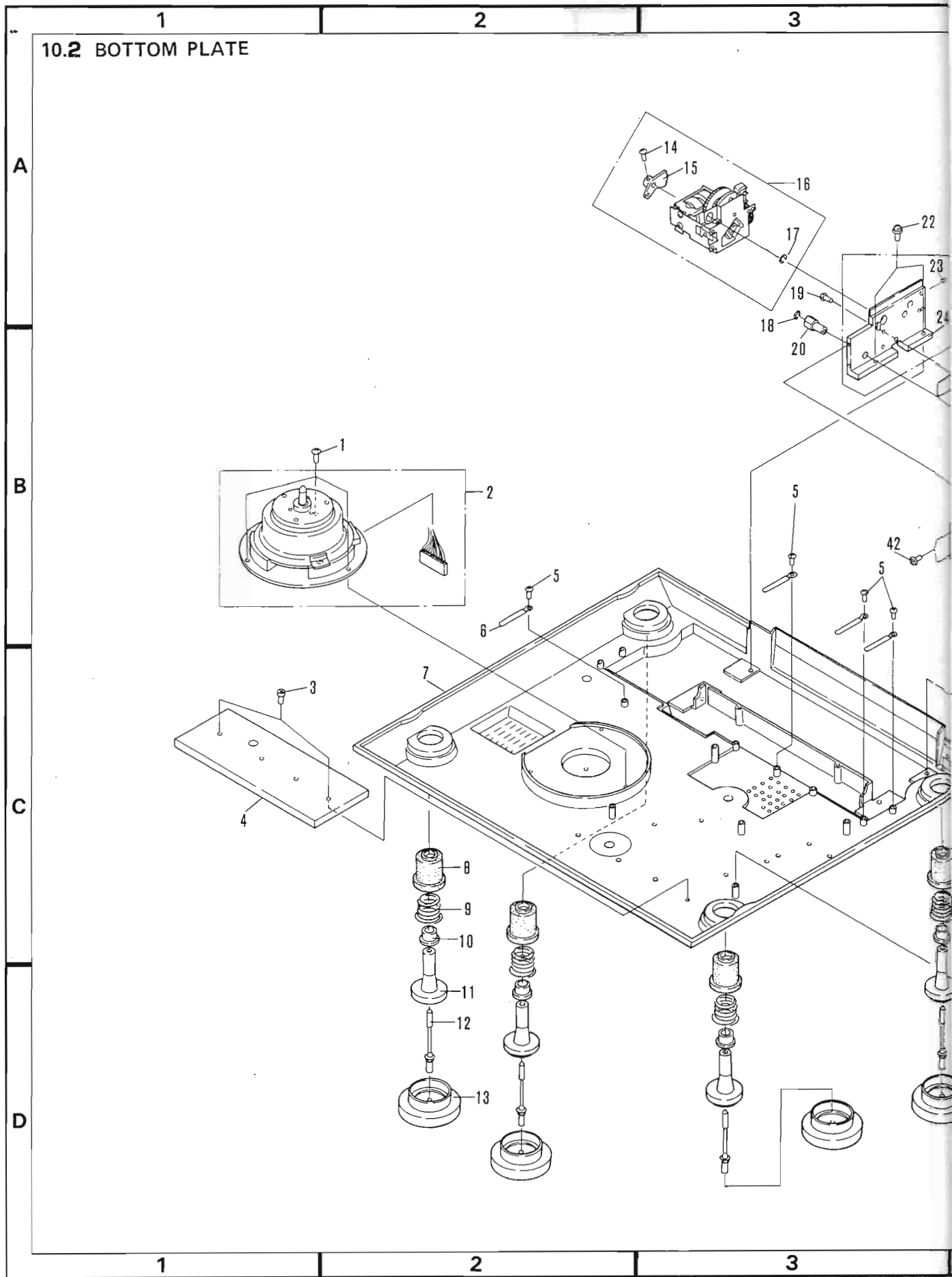

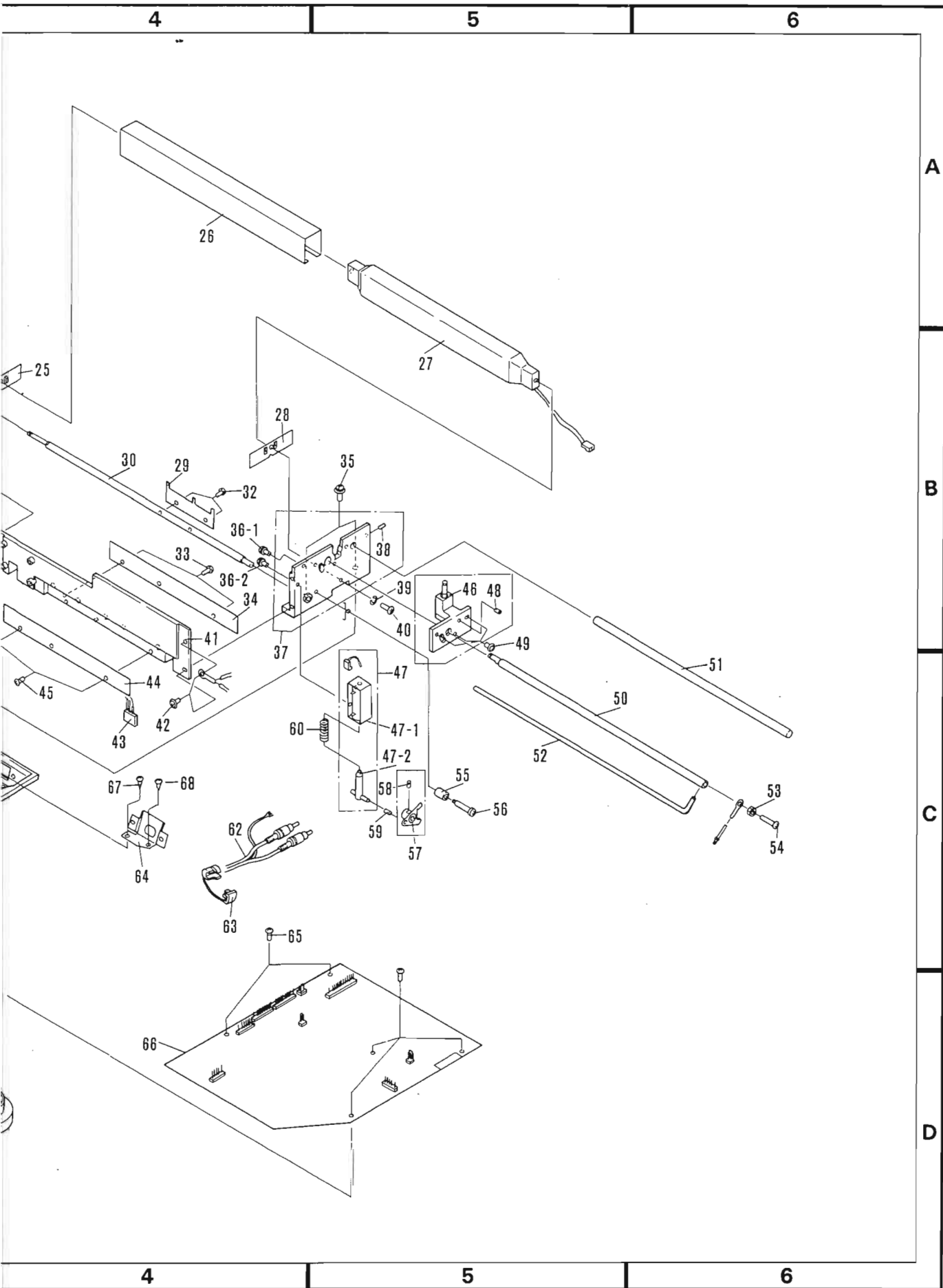

Parts List of Tonearm

NOTE: *Parts without part number CANNOT be supplied.

<u>Key No.</u>	<u>Part No.</u>	<u>Description</u>	<u>Key No.</u>	<u>Part No.</u>	<u>Description</u>
1.	943-8009	Counterweight	31.		Base B
2.	930-8023	Tonearm assy.	32.	922-8025	Washer
3.			33.	930-8025	Bearing
4.	930-8019	Headshell	34.	921-8059	Spacer
5.			35.	943-8010	Roller
6.			36.	930-8026	Bearing
7.	930-8029	EV sheet assy.	37.	922-8034	Shaft
7-1.		Stopper	38.		Magnet
7-2.		Spring	39.	922-8025	Washer
7-3.		Clamper	40.	930-8026	Bearing
7-4.		EV sheet unit	41.	943-8011	Shaft holder A
8.	922-8065	Setscrew:HS3 x 5	42.	930-8025	Bearing
9.	930-8020	Base assy.	43.		
10.	922-8047	Screw	44.	930-8024	Shafter holder B
11.			45.	942-8039	Rubber cap
11-1.	941-8012	Sensor board	46.		
11-2.	942-8061	Spacer	47.		
11-3.	928-8005	CdS	48.		
12.	922-8012	Screw:PM2.6 x 6	49.		
13.		Tracking shutter	50.	922-8039	EV adjust screw
14.	922-8066	Screw:PM2.6 x 5	51.	921-8055	EV spring
15.		Terminal	52.	930-8034	EV shaft
16.	922-8025	Washer: FW2.6 x 5 x 0.5t	53.		Plastic washer
17.	922-8012	Screw:PM2.6 x 6			
18.	901-8004	Lamp PCB assy.			
18-1.	942-8037	Coupler base			
18-2.	921-8015	Lamp			
18-3.		Sensor board			
18-4.	922-8079	Screw:PT2.6 x 8			
19.	922-8079	Screw:PT2.6 x 8			
20.	922-8048	Screw:PSA3 x 5			
21.		Shutter			
22.	922-8067	Washer faced alutite screw:3 x 6			
23.		Plate			
24.	930-8032	Pin unit			
25.	922-8033	Screw			
26.		Shield tube			
27.	921-8036	Spring			
28.	921-8036	Spring			
29.	941-8022	Rubber pad			
30.	922-8028	Screw			

10.3 TÖNEARM

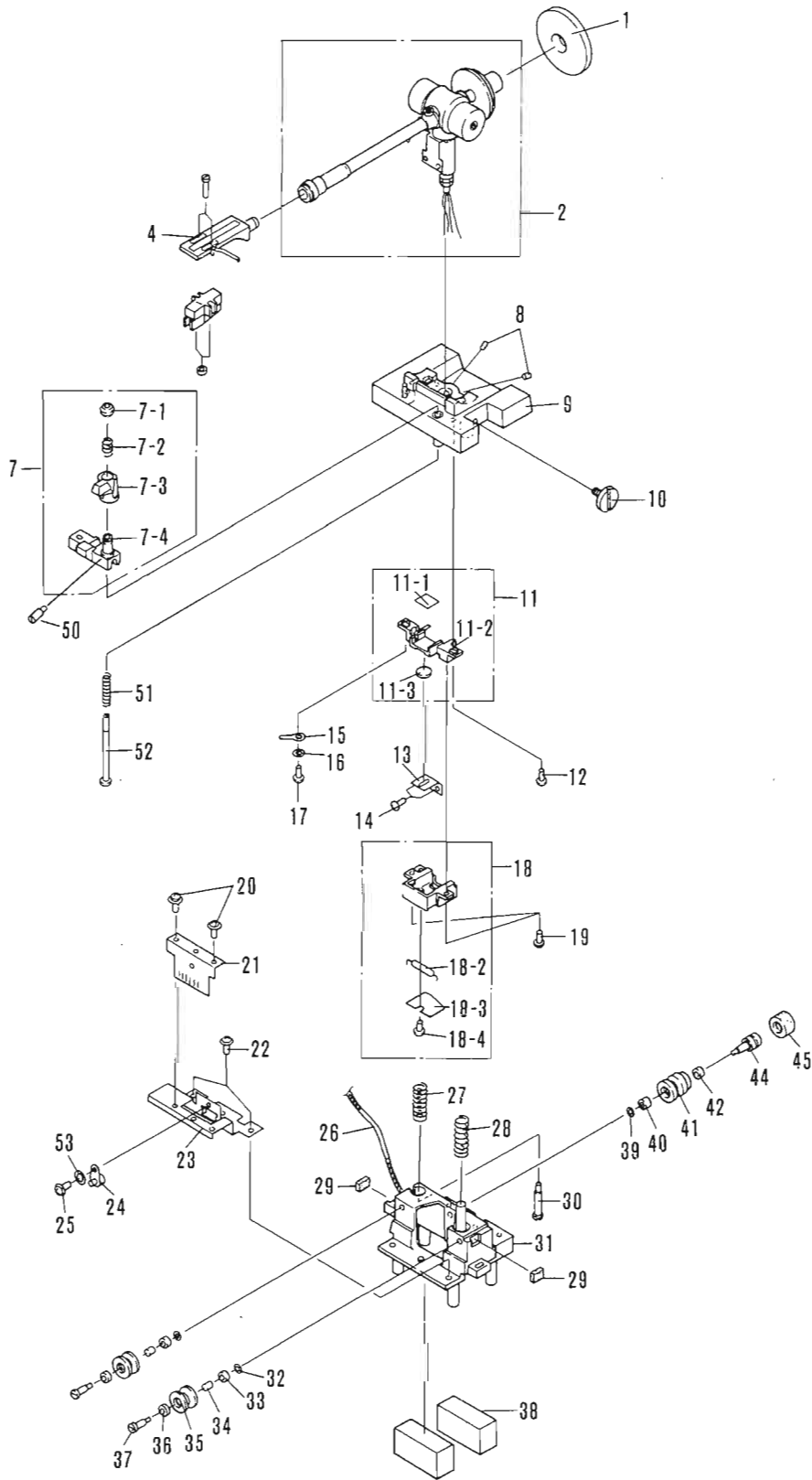

10.4 EV MECHANISM

NOTE: *Parts without parts numbers CANNOT be supplied.

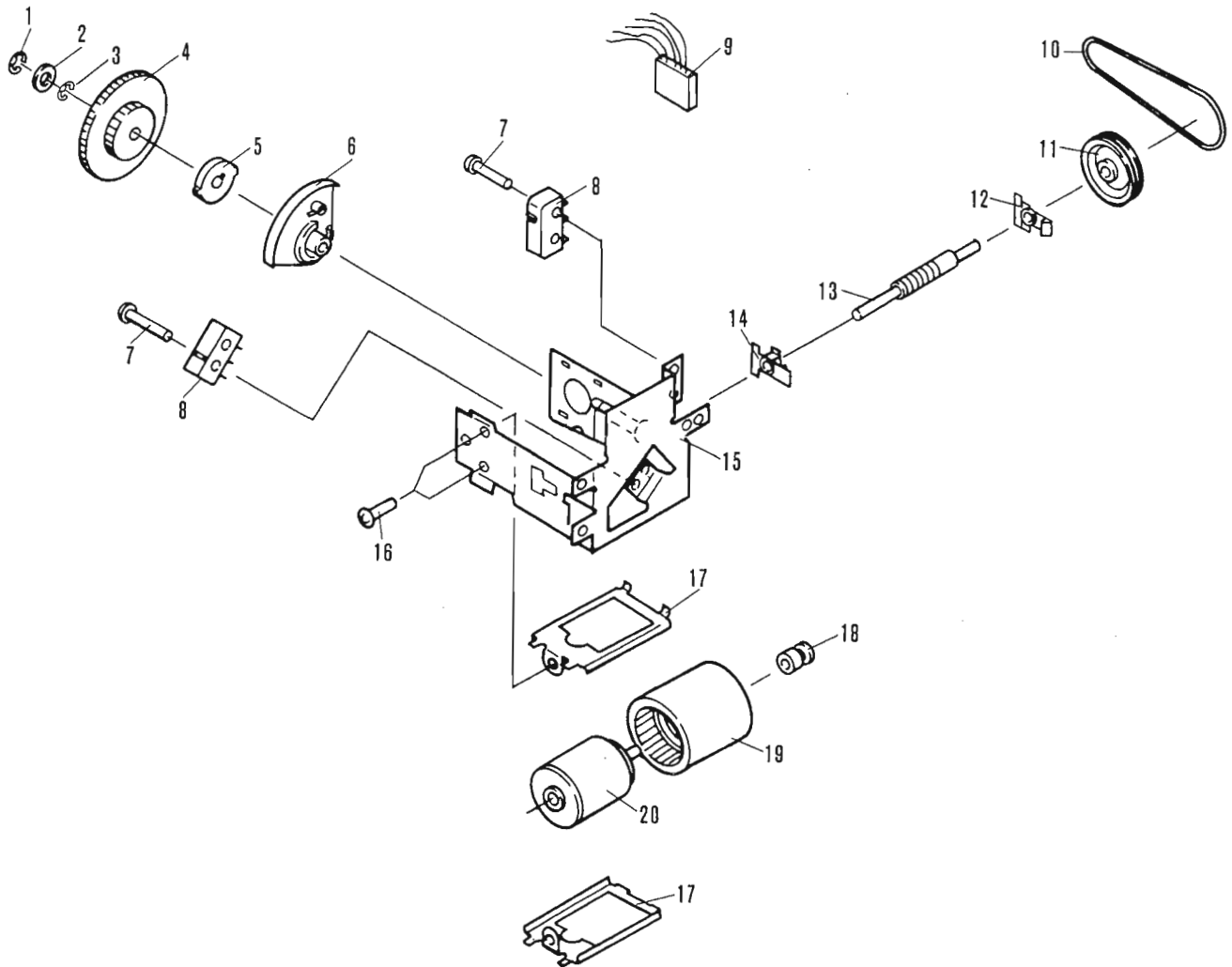

Parts List

Key No.	Part No.	Description	Key No.	Part No.	Description
1.	922-8048	Circlip:EW3	11.	942-8044	Pulley
2.	922-8029	Washer	12.	942-8045	Collar
3.	922-8024	Washer	13.	930-8018	Worm gear
4.	942-8049	Gear F.	14.	942-8045	Collar
5.		Plate	15.		Chassis
6.	942-8043	Cam	16.	922-8017	Screw:PSA2.6 x 5
7.	922-8068	Screw:PT2 x 10	17.		Frame
8.	929-8022	Microswitch	18.	942-8071	Motor pulley
9.	924-8021	Connector harness	19.	942-8038	Tube
10.	942-8067	Belt	20.	929-8050	Motor

11. PACKING

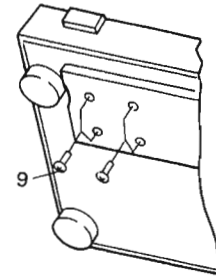
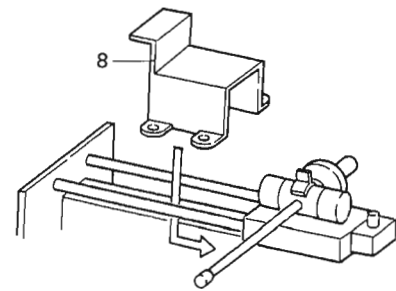
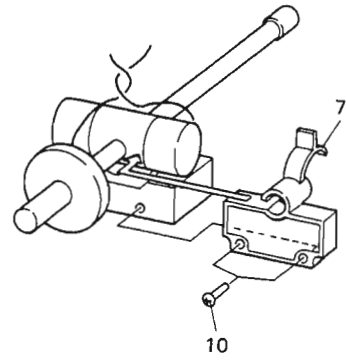
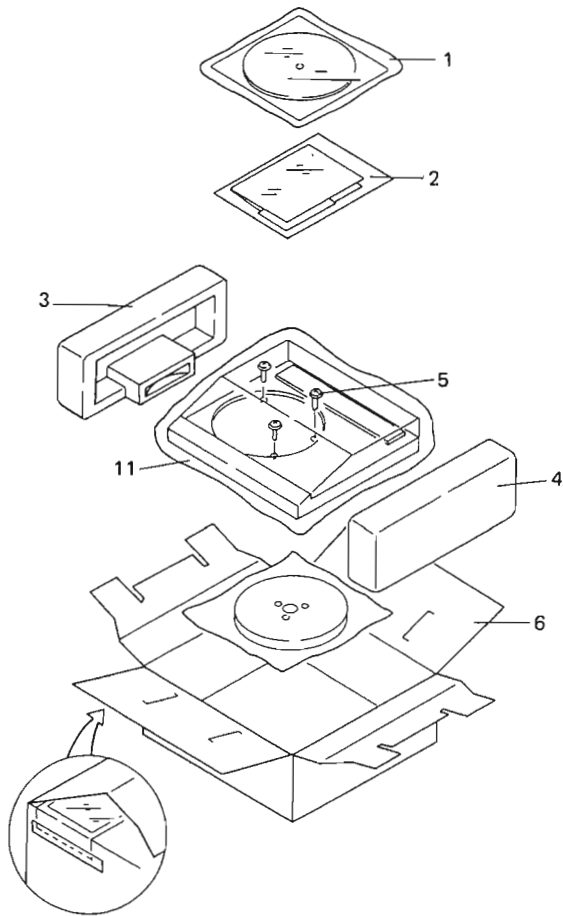

Parts List:

Key

No.	Part No.	Description
1.	942-8073	Rubber mat assy.
2.		Owner's manual
3.	952-8004	Protector:L
4.	952-8005	Protector:R
5.	922-8032	Screw
	922-8080	Fiber washer
6.	952-8007	Shipping box
7.	942-8057	Arm holder
8.	942-8056	Spacer
9.	922-8081	Screw:PSB4 x 12
10.	922-8082	Screw:PSB3 x 15
11.	952-8006	Plastic cover

Accessories:

Key

No.	Part No.	Description
	943-8009	Counterweight
	930-8035	Screwdriver
	942-8070	EP (45RPM) adaptor
	922-8036	Cartridge mount kit
	942-8036	Overhang gauge
		Cleaning cloth
	930-8022	Bubble level

NOTE: * With the exception of the owner's manual, parts without part number CANNOT be supplied.

12. PARTS LISTS OF PC BOARD ASSEMBLIES

NOTE: *The Δ mark found on some component parts indicates the importance of the safety factor of the part. Therefore, when replacing, be sure to use parts of identical description.

Parts List of Control PCB Assembly (901-8012)

SEMICONDUCTORS:			VARIABLE RESISTORS:		
<u>Part No.</u>	<u>Description</u>	<u>Symbol</u>	<u>Part No.</u>	<u>Description</u>	<u>Symbol</u>
926-8023	PD1003	IC1	929-8025	6.8K-B	VR1
926-8028	PA2004	IC2	929-8017	10K-B	VR2
926-8031	PA2005	IC3	929-8056	680K-B	VR3
926-8049	NJM2903D	IC4	929-8053	680K-B	VR4
926-8114	JC4013BP	IC5	929-8055	33K-B	VR5, VR6
926-8046	TD62504P	IC6	929-8054	220-B	VR7
926-8052	M54517P	IC7	929-8057	330-B	VR8
926-8056	TC4001BP	IC8, IC13, IC17, IC18	929-8001	3.3K-B	VR9
926-8050	TC4023BP	IC9	MISCELLANEOUS:		
926-8118	TC4011BP	IC10, IC11, IC14	926-8103	Crystal	X-tal
926-8044	TC4027BP	IC12, IC15	928-8006	Thermistor	TH1, TH2
926-8113	TC4069UPB	IC16			
926-8115	uPC4558C	IC20, IC21			
926-8048	uPC78L08	IC22			
926-8002	2SC945	Q1-Q5, Q7, Q8			
926-8030	(2SC1815)				
926-8003	2SC1583	Q6			
926-8005	2SC1626	Q9, Q11			
926-8020	2SA816	Q10, Q12			
926-8107	2SA562TM-Y	Q13, Q14			
926-8051	2SC1959-Y	Q15, Q16			
926-8041	WZ-085	D1			
926-8035	IS1885	D2			
926-8037	IS2473	D3, D4, D6, D8-D10, D14, D15			
926-8116	VD1212	D5, D7			
926-8108	RD2.4EB	D12			
926-8089	WZ-150	D13			

* * * * *

Parts List of Power Supply PCB Assembly (901-8002)

SEMICONDUCTORS:			CAPACITORS:		
<u>Part No.</u>	<u>Description</u>	<u>Symbol</u>	<u>Part No.</u>	<u>Description</u>	<u>Symbol</u>
926-8047	uPC78MD8H	IC101	Δ 927-8008	.047/450:myl	C101
926-8109	2SD686	Q101	RESISTORS:		
926-8036	SLRBA10	D101	928-8007	2W:1K	R101
926-8053	S2VB10	D102	HARDWARE:		
926-8097	BZ-250	D103	921-8057	Spacer	
			921-8058	Spacer	
			922-8031	Screw	

Parts List of Lamp PCB Assembly (901-8004)

Part No. Description Symbol

921-8015 8V 70mA lamp PL1

* * * * * * * * * * * * * *

Parts List of LED Sensor PCB Assembly (901-8003)

Part No. Description Symbol

926-8042 LED D301-D305

* * * * * * * * * * * * * *

Parts List of CdS PCB Assembly (901-8016)

Part No. Description Symbol

928-8005 CdS CdS

* * * * * * * * * * * * * *

Parts List of Phototransistor PCB Assembly (901-8017)

Part No. Description Symbol

926-8043 TPS605-Y Q301-Q305

* * * * * * * * * * * * * *

Parts List of Control A PCB Assembly (901-8018)

Part No. Description Symbol

926-8101 GL-2PR1 D201-D206
929-8015 Switch S3, S4

* * * * * * * * * * * * * *

Parts List of Control B PCB Assembly (901-8019)

Part No. Description Symbol

926-8101 GL-2PR1 D207-D209
929-8015 Switch S5-S7

MODEL 8000 SERIES TWO

SCHEMATIC DIAGRAM

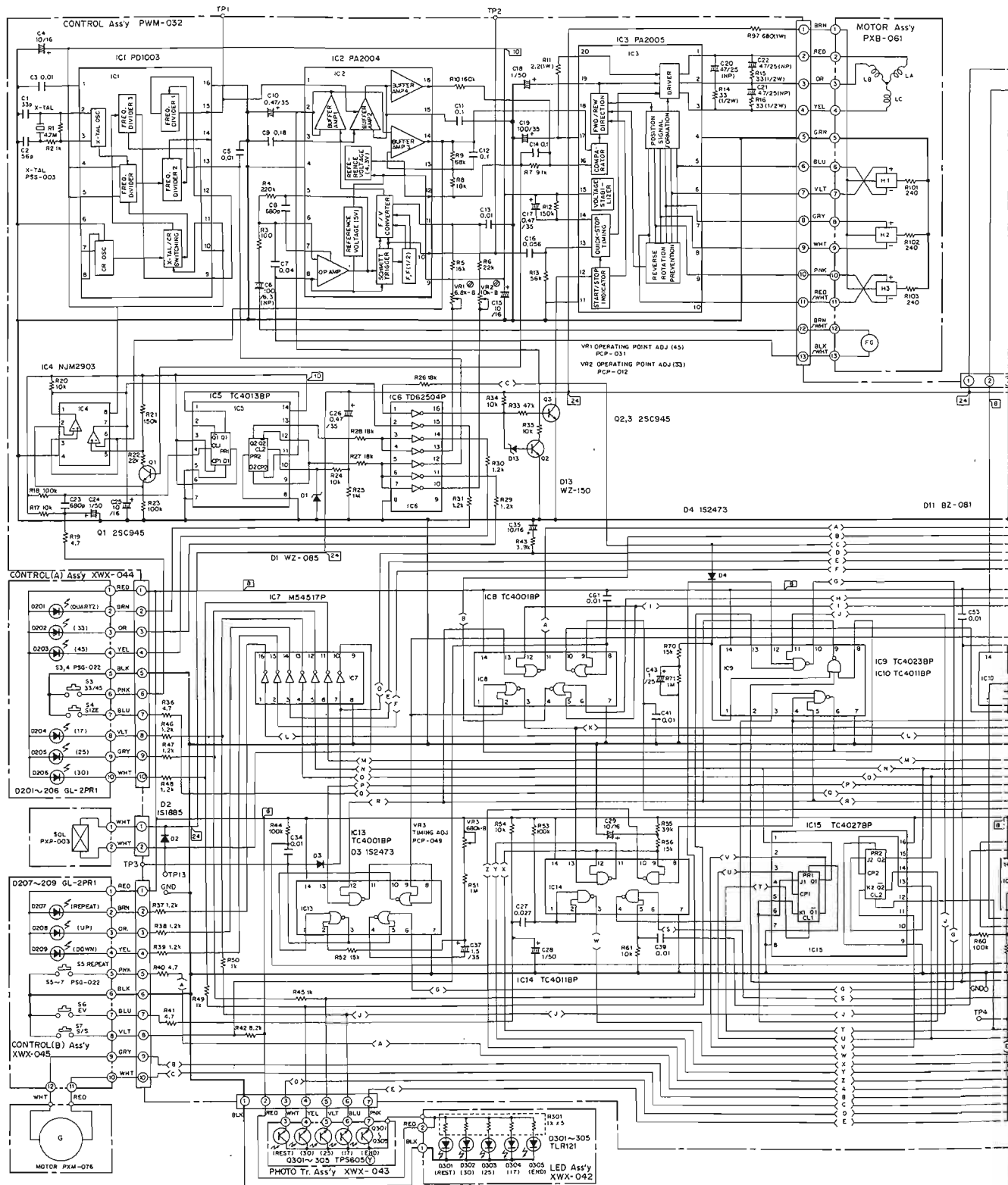

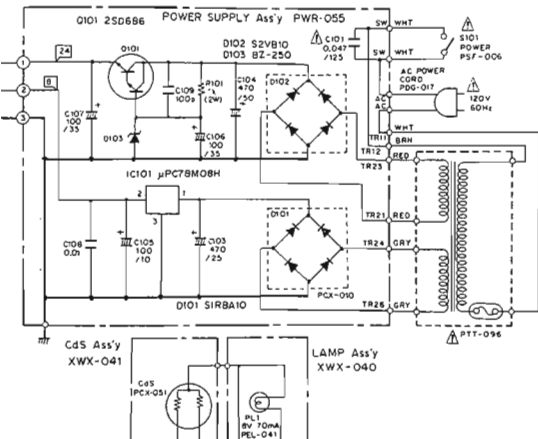

- 1. RESISTORS:**
 Indicated in Ω , $\text{k}\Omega$, 5% tolerance unless otherwise noted k : k Ω .
 M : M Ω , (F) : 1%, (G) : 2%, (K) : 10% tolerance
- 2. CAPACITORS:**
 Indicated in capacity (μF)/voltage (V) unless otherwise noted μ : μF
 Indication without voltage is 50V except electrolytic capacitor.
- 3. VOLTAGE**
 \square : DC voltage (V) at no input signal
- 4. OTHERS:**
 \otimes : Adjusting point.
 The Δ mark found on some component parts indicates the importance of the safety factor of the part. Therefore, when replacing, be sure to use parts of identical designation

- SWITCHES:**
- | | |
|-------------------|-----------------|
| S1: UP DETECTOR | ON — OFF |
| S2: DOWN DETECTOR | ON — OFF |
| S3: SPEED | 33 rpm — 45 rpm |
| S4: SIZE | 17 — 25 — 30 |
| S5: REPEAT | ON — OFF |
| S6: ARM-ELEVATION | DOWN — UP |
| S7: START/STOP | START — STOP |
| S10: POWER | ON — OFF |
- The underlined indicates the switch position.

This is the basic schematic diagram, but the actual circuit may vary due to improvements in design.

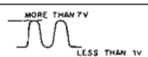
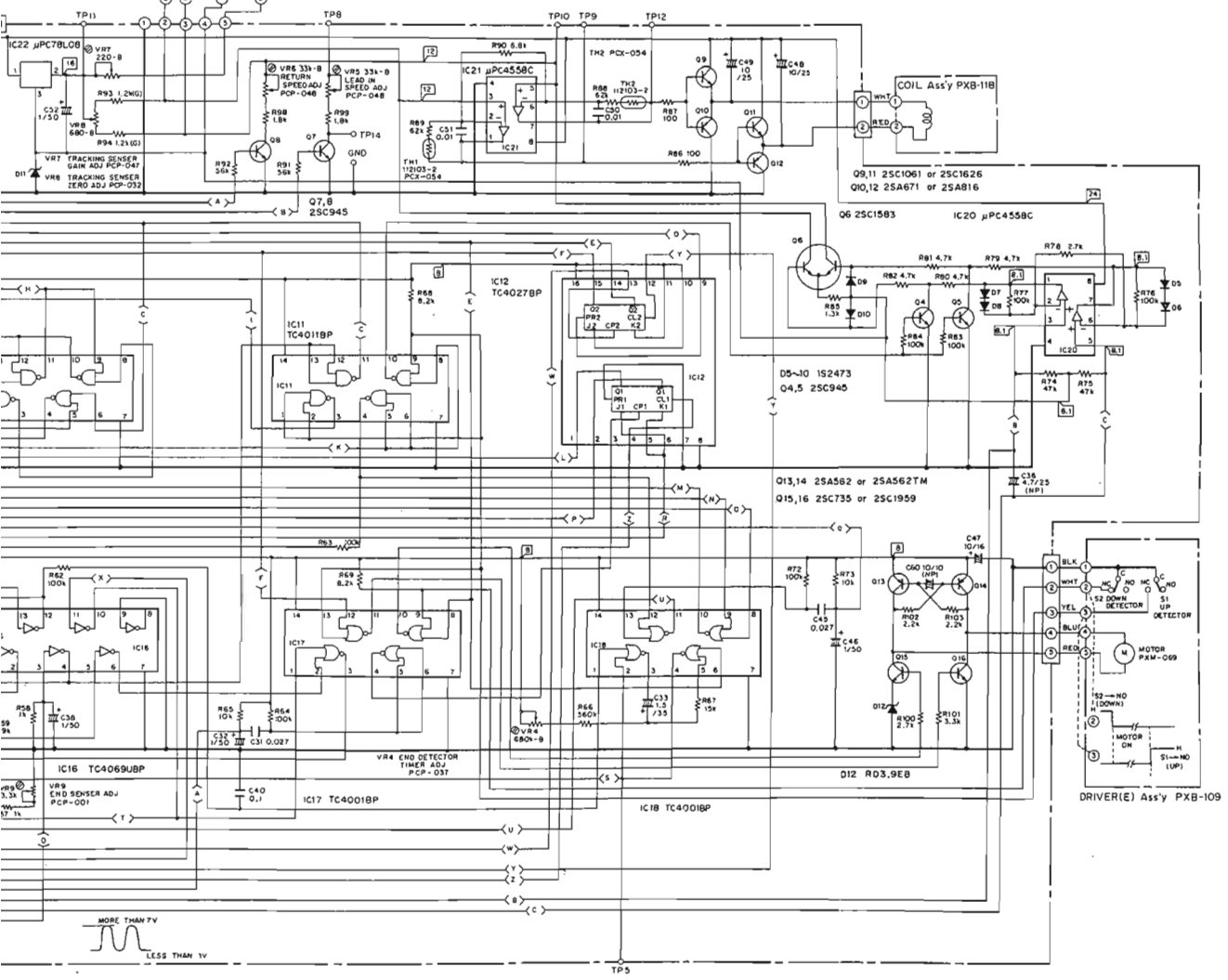

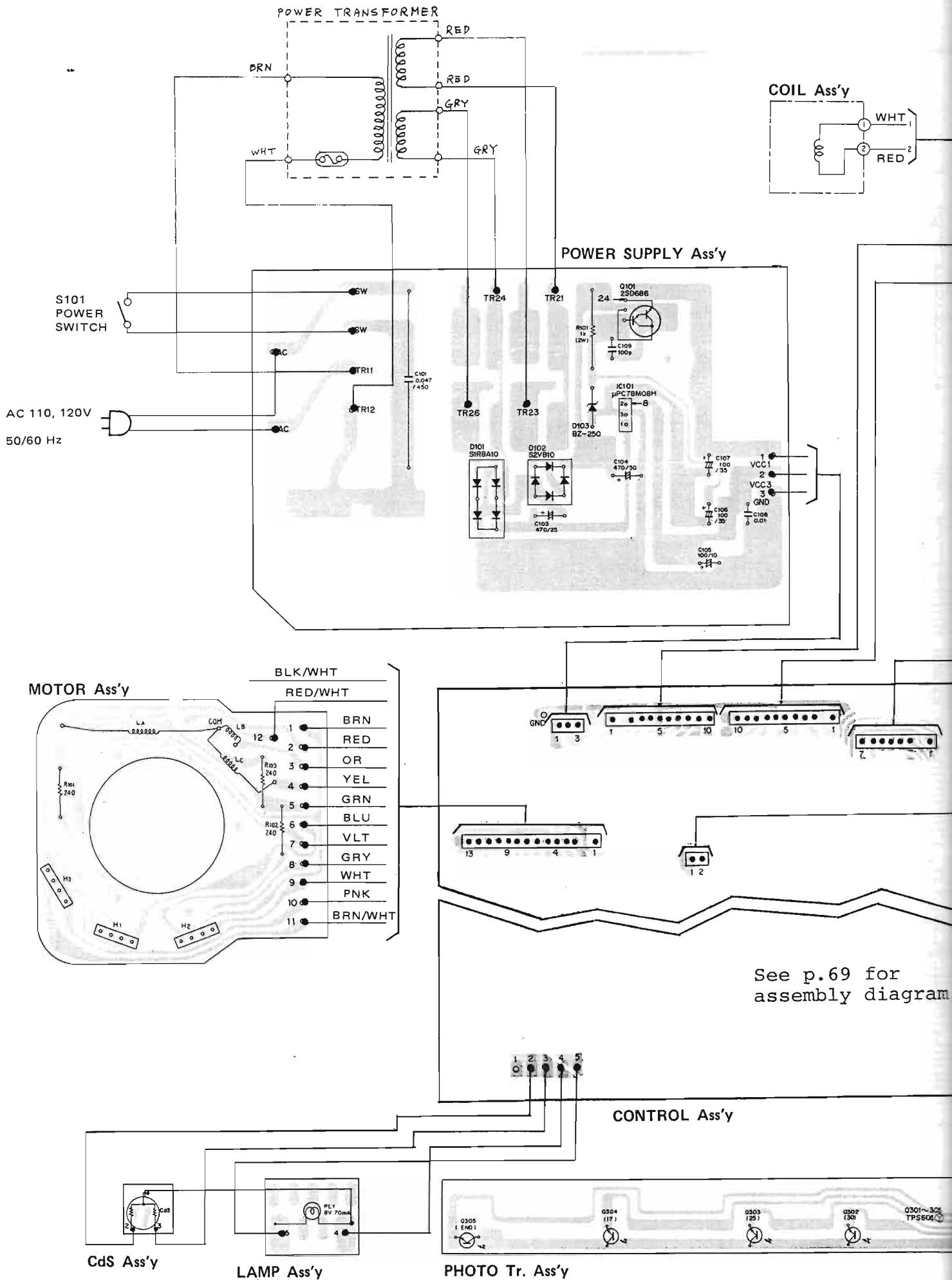

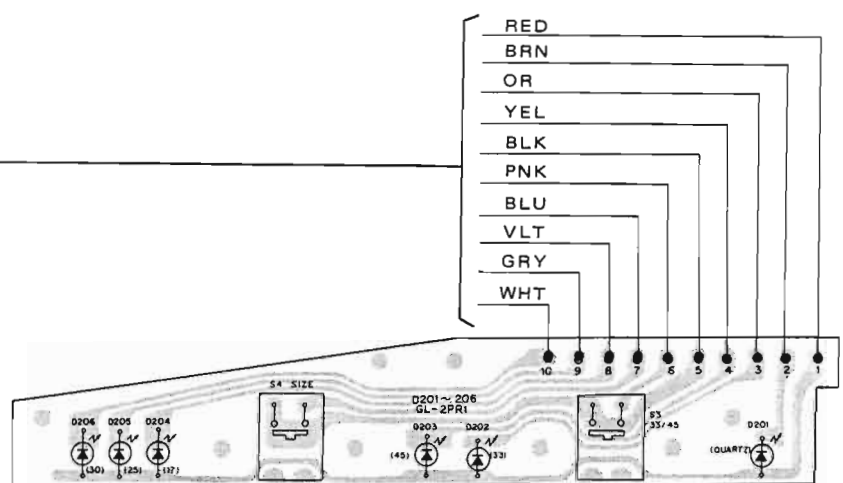

CONTROL (A) Ass'y

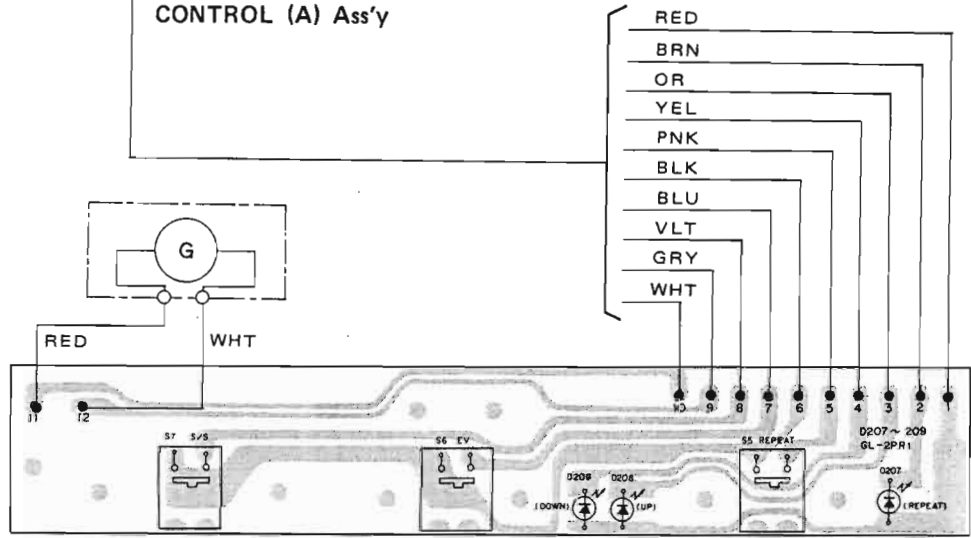

CONTROL (B) Ass'y

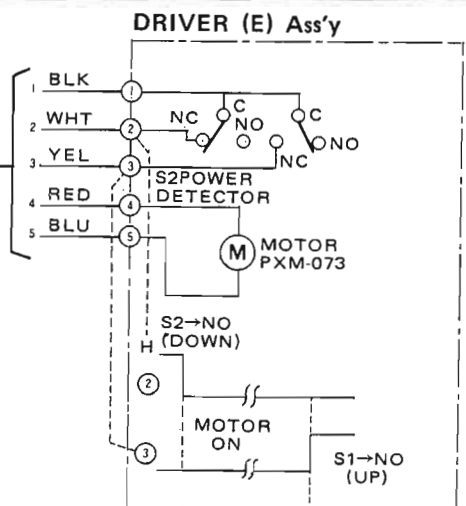

DRIVER (E) Ass'y

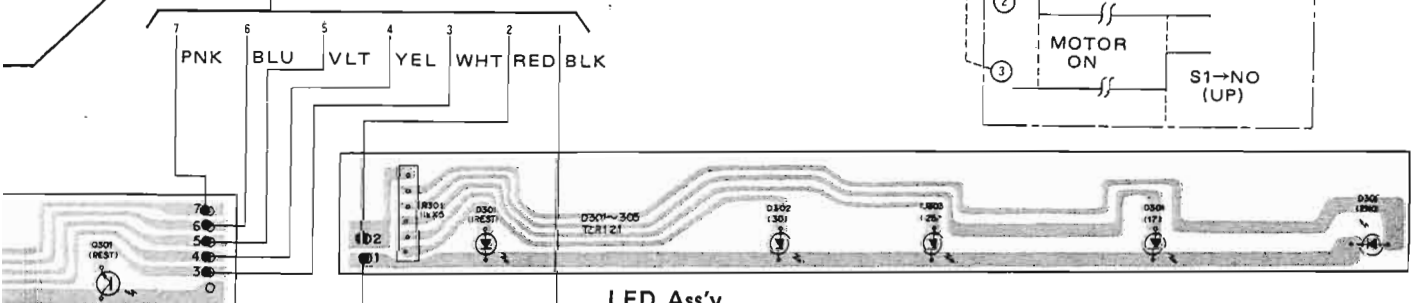

LED Ass'y

12.1 CONTROL PCB ASSEMBLY (901-8012)

NOTE: * See pp. 67 and 68 for interconnect diagrams.

