

Service
Service
Service



Service Manual



TABLE OF CONTENTS

Technical specification 1-1
 Features 1-1

Accessories 1-1
 Instruction For Use 1-2.. 1-6
 Safety & Warnings 1-7

Service hints

Repair positions 2-1
 Dismantling CD-door 2-1
 Handling chip components 2-2
 Service tools 2-2

Pin description of ICs 3-1.. 3-8
 Start-up procedure 3-9
 Service Test Program 3-10
 Service Test Program-flow chart 3-10
 Blockdiagram 3-12

Circuit diagrams

Control/Supply part 4-1
 Drive/EPs part 4-2
 Audio part 4-3

Layout diagrams

Copper side view 4-4
 Component side view 4-5

Exploded view diagram 5-1
 Mechanical partslist 5-1

Electrical partslist 6-1.. 6-2



© Copyright 2003 Philips Consumer Electronics B.V. Eindhoven, The Netherlands
 All rights reserved. No part of this publication may be reproduced, stored in a retrieval
 system or transmitted, in any form or by any means, electronic, mechanical, photocopying,
 or otherwise without the prior permission of Philips.

Published by LX 0334 Service Audio Printed in The Netherlands Subject to modification

GB 3140 785 32620



PHILIPS

TECHNICAL SPECIFICATION

General

Dimensions (Dia x H)	: 146 x 24 mm
Weight without batteries	: 220g

Shock resistance

+X/-X direction	: $\geq 2.5g$
+Y/-Y direction	: $\geq 2.5g$
+Z/-Z direction	: $\geq 2.0g$

Power supply modes

SUPPLY MODE	Voltage range
DC-IN socket	2.5 - 6.0V
Primary batteries	1.8 - 3.6V
Rechargeable batteries	1.8 - 3.6V

Battery lifetime

BATTERY TYPE	at PSM in lim	at PSM in typ	at ESP=on in lim	at ESP=on in typ
Primary batteries 2 x AAA	≥ 10 h	12h	≥ 8 h	10h
Rechargeable batteries AY3363	≥ 5 h	6h	≥ 3.5 h	4h

Battery level detection

DETECTION LEVEL	Primary batteries
Battery empty	1.8V +100/-50mV
Difference btw.battery level 1 and battery empty	battery empty level + 0.3V \pm 100mV
Difference btw.battery level 2 and battery empty	battery empty level + 0.45V \pm 150mV
Difference btw.battery level 3 and battery empty	battery empty level + 0.75V \pm 100mV

Measurement setup CD

Use Audio Signal disc SBC429

4822 397 30184

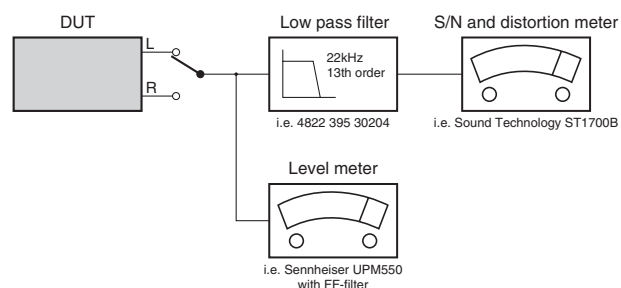

Current consumption

OPERATION MODE	DC-IN SUPPLY (4.5V)		BATT. SUPPLY (2.25V)	
	Powersave	ESP= ON	Powersave	ESP= ON
PLAY	80mA typ.	120mA typ.	80mA typ.	120mA typ.
CHARGE	150mA	150mA	n/a	n/a
JUMP	400mA typ.		400mA typ.	
Stand- by (excl.recharge)	90mA typ.		<1mA	

Headphone out (measured with 16Ω load, DBB/ESP off)

Output power (THD=10%)	
/17 version only	: 8mW (+1/-3dB)
all other versions	: 4mW (+2/-2dB)
Frequency response (1mW)	: 100Hz-20kHz within 6dB
S/N ratio (unw.)	: ≥ 80 dB (82dB typ.)
S/N ratio (A-wght)	: ≥ 82 dB (84dB typ.)
THD+N CD (1kHz, 1mW)	: $\leq 1\%$ (0.2% typ.)
Crosstalk (1kHz, w/o load)	: ≤ -24 dB (-44dB typ.)
Channel unbalance (-40dB)	: ≤ 5 dB
Volume attenuation (1kHz)	: > 60 dB

Dynamic Bass Boost DBB

DBB STAGE	Frequency response		
	63Hz	1kHz	10kHz
DBB 1	+8dB \pm 2dB	0dB \pm 2dB	0dB \pm 2dB

Feature Overview

FEATURES OF PORTABLE CD PLAYER	ACT500 (all versions)
TUNER FM / MW	- / -
CD-REWRITABLE COMPATIBILITY	●
ELECTRONIC SKIP PROTECTION CDDA / MP3	90s / -
ESP DRAM SIZE	32Mbit
HOLD / RESUME FUNCTION	● / ●
DBB STAGES	1
ACOUSTIC FEEDBACK	-
PROGRAM MEMORY	-
RECHARGE FUNCTION NiCd / NiMH	- / ●
CORD REMOTE CONTROL PREPARED	●

ACCESSORIES

ACCESSORIES FOR PORTABLE CD PLAYER	ACT500				
	/00C	/01	/05	/11	/17
AY 3170/00 AC/DC Adaptor 3140 118 33630	X				
AY 3170/02 AC/DC Adaptor 3140 118 32020		X			
SBC HJ050/77E Stereo Headphone 9082 100 02179	X	X	X	X	X
AY3293 Carry Pack 3140 113 10641	X	X	X	X	X
AY3363 Battery-NIMH-AAA 3103 308 84721	X	X			
Battery ALK 1.5V LR03PL 9082 100 90013			X	X	X
AY3781 Remote control 3140 118 51511	X	X	X	X	X
Waist Belt 3140 113 10581	X	X	X	X	X
Butterfly-NIKE 3140 118 72161	X	X	X	X	X
GR1-AX Mains Plug Adaptor 3139 128 73011		X			

INSTRUCTION FOR UES

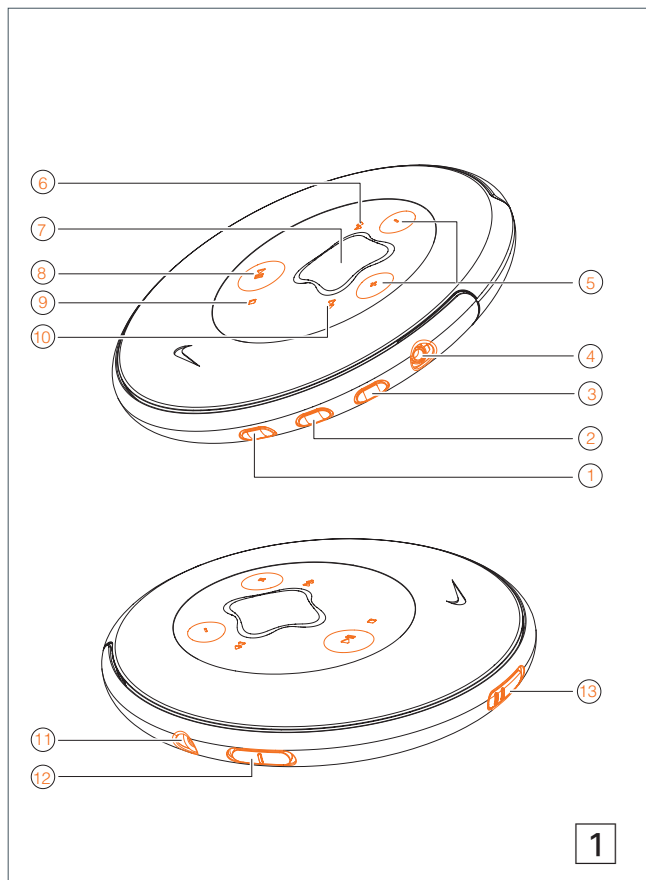

english controls

supplied accessories

- 1 x headphones, HJ050
- 1 x remote control, AY3781
- 1 x AC/DC adapter, AY3170
- 2 x rechargeable batteries, AY3363
- 1 x hand strap / waist pack, AY3293

controls (see figure 1)

- ① modeselects the different playing possibilities: **shuffle**, **shuffle repeat**, **repeat** and
- ② eqswitches the bass enhancement on and off. this button also switches acoustic feedback (the beep) on/off when it is pressed for more than 2 seconds
- ③ esptoggle to select between the battery powersave mode and **electronic skip protection (esp)**. esp ensures continuous cd playback regardless of vibrations and shocks
- ④3.5 mm headphone socket, socket to connect the player to another audio input of an additional appliance, remote control socket
- ⑤adjusts the volume
- ⑥skips and searches cd tracks backwards
- ⑦ indicatorlights up : red (battery low / power down) , green (power up), orange (pause mode)
- ⑧switches the player on, starts or pauses cd play
- ⑨stops cd play, switches the player off
- ⑩skips and searches cd tracks forwards
- ⑪ DCsocket for external power supply

QUICK START

MISE EN SERVICE RAPIDE

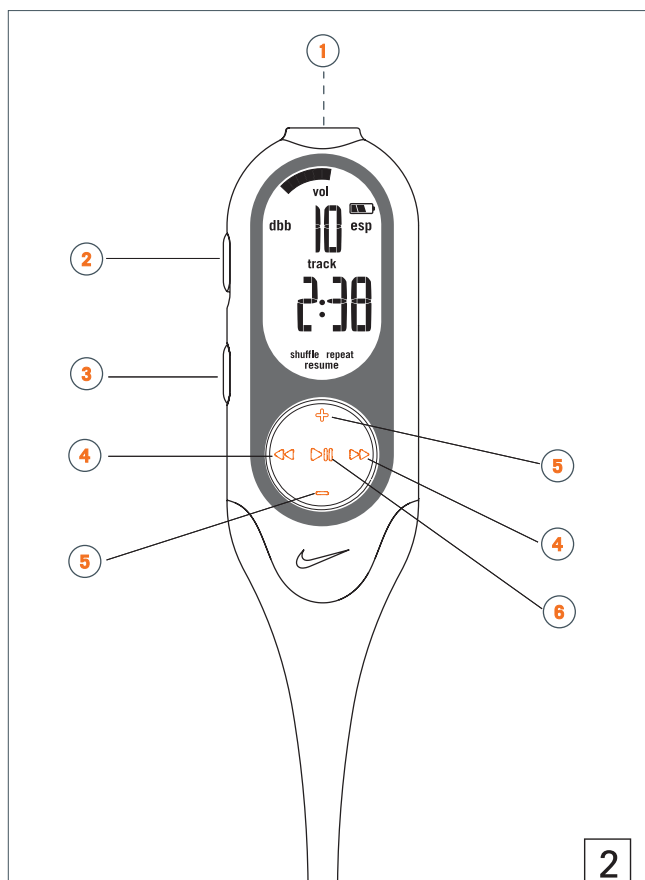
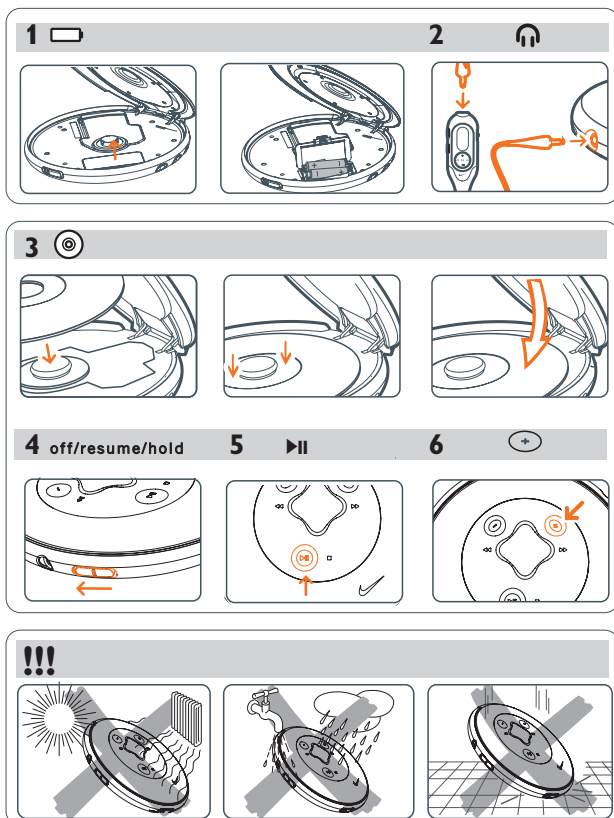







INSTRUCTION FOR USE

controls / accessories

controls (see figure 1)



- ⑫ off.....switches resume and hold off
 resume.....stores the last position of a cd track played
 holdlocks all buttons
- ⑬ opens the cd lids

remote control AY3781 (see figure 2)

- ① 3.5 mm headphone plug to connect to headphones socket
- ② holdlocks all buttons
- ③ stop.....stops playback and switches the set off
- ④  skips and searches forward / backward tracks
- ⑤  adjusts the volume
- ⑥ switches the set on, starts playback and interrupts playback

connecting the remote control

use only the AY 3781 remote control.

- press  on the set twice to switch off the set.
- firmly connect the remote control to  on the set.
- firmly connect the headphones to the plug on the remote control.
- on the remote control keep  pressed for 1 second to switch on the set and to start playback.
- adjust the volume and sound on the psa and your remote control.

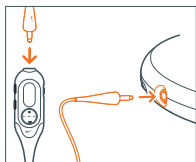

clip magnets

wear your remote control and secure your headphone cord with these wearable magnets.

- check the polarity of the 2 button magnets. insert the big button magnet underneath your garment.
- clip the small button magnet on your outer garment. clip the remote control on top.
- secure your headphone cord with the "butterfly" magnet clip.

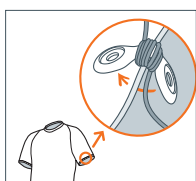
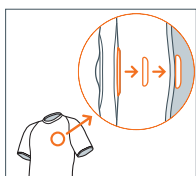
**WARNING:**

–KEEP OUT OF REACH OF SMALL CHILDREN TO AVOID CHOKING HAZARD.

–KEEP THE MAGNETS AWAY FROM CREDIT CARDS, TAPES AND ANY ITEMS, WHICH MAY BE SENSITIVE TO THE MAGNETS.

–USERS OF PACEMAKERS OR OTHER IMPLANTED DEVICES SHOULD CONSULT THEIR PHYSICIAN BEFORE USING MAGNETS OR DEVICES THAT MAY GENERATE ELECTRO-MAGNETIC INTERFERENCE.

caution

use of controls or adjustments or performance of procedures other than herein may result in hazardous radiation exposure or other unsafe operation.

accessories / power supply

hand strap / waist pack AY3293

wear your cd player during sport activity by securing it to the supplied hand strap / waist pack.

- open the strap enclosure on the back of the hand strap / waist pack and slide the cd player inside. make sure the headphone / remote socket is aligned to the socket hole.

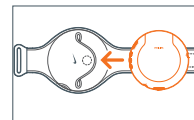

- thread the strap.

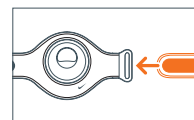

- position your hand and adjust the strap until the fit is snug and comfortable.

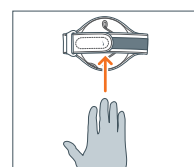

this set complies with the radio interference requirements of the European Community.

the model and serial numbers are located inside the cd door.

batteries (supplied or optionally available)

you can use the following batteries with this cd-player:

- alkaline batteries type AAA (LR03, UM4) or rechargeable ECO-PLUS NiMH battery.

notes: old and new or different types of batteries should not be combined. remove batteries if they are empty or if the player is not going to be used for a long time.



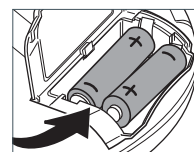

inserting batteries

- push  to open the cd door
- open the cd compartment and insert 2 x AAA batteries.



battery indication

the approximate power level of your batteries is shown in the display.(on remote control)

-  battery full
 -  battery two-thirds full
 -  battery one-third full
 -  battery dead or empty. when the batteries are dead or empty, the symbol  flashes, no bdt is displayed, and the beep tone sounds repeatedly.
- indicator lights up orange and beeps briefly.
 indicator then turns red before player switches off.



average playing time of batteries under normal conditions

battery type	esp + power save
normal AAA	3 hours
alkaline AAA	12 hours
rechargeable ECO-PLUS NiMH battery	10 hours

batteries contain chemical substances, so they should be disposed of properly.

INSTRUCTION FOR USE

power supply / general information

ECO-PLUS NiMH battery information (for versions supplied with the rechargeable ECO-PLUS NiMH battery AY 3363)

recharging works only on players supplied with the rechargeable ECO-PLUS NiMH battery AY 3363.

recharging the ECO-PLUS NiMH battery on board

- 1 insert the rechargeable ECO-PLUS NiMH battery AY 3363.
- 2 connect the mains adapter to the DC socket of the player and then to the wall socket.
 -  is pulsing.

- recharging stops after a maximum of 7 hours, or when you start playback.

- 3 when the battery is fully recharged, FULL appears in the display.



notes:

- it is normal for the batteries to become warm during recharging.
- if the batteries become too warm, recharging will be interrupted for approximately 30 minutes and  is displayed.
- to ensure proper recharging on board, take care that contacts are clean.
- use only the ECO-PLUS NiMH battery AY 3363.

handling instructions

- recharging already charged or half-charged batteries will shorten their lifetime. we therefore recommend that you let the rechargeable ECO-PLUS NiMH battery run till it is completely empty before you recharge it.
- to avoid a short circuit, do not let the battery touch any metal object.
- if the battery becomes empty soon after recharging, then either its contacts are dirty or it has reached the end of its lifetime.

mains adapter (supplied or optionally available)

use only the AY 3170 power adapter supplied with your product (4.5 V / 300 mA direct current, positive pole to the centre pin). any other product may damage the player.

- 1 make sure the local voltage corresponds to the adapter's voltage.
- 2 connect the adapter to the DC socket of the player and to the wall socket.

note: always disconnect the adapter when you are not using it.

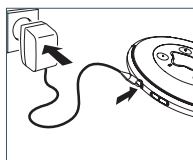

environmental information

- all redundant packing material has been omitted. we have done our utmost to make the packaging easily separable into two mono materials: cardboard and polyethylene.
- your set consists of materials which can be recycled if disassembled by a specialized company. please observe the local regulations regarding the disposal of packing materials, exhausted batteries and old equipment.

headphones HJ050

- connect the supplied headphones to the  socket of the player.

note:  can also be used for connecting this set to your hifi system to adjust the sound and volume, use the controls on the connected audio equipment and on the cd player.

take care when using headphones

hearing safety: listen at a moderate volume. using headphones at high volume can impair your hearing.

traffic safety: do not use headphones while driving or cycling as you may cause an accident.

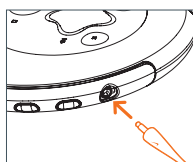

general information / cd play

cd player and cd handling

- do not touch the lens  of the cd player.
- do not expose the unit, batteries or cds to humidity, rain, sand or excessive heat (caused by heating equipment or direct sunlight).
- you can clean the cd player with a soft, slightly dampened, lint-free cloth. do not use any cleaning agents as they may have a corrosive effect.
- to clean the cd, wipe it in a straight line from the center toward the edge using a soft, lint-free cloth. a cleaning agent may damage the disc! never write on a cd or attach a sticker to it.
- the lens may cloud over when the unit is moved suddenly from cold to warm surroundings. playing a cd is not possible then. leave the cd player in a warm environment until the moisture has evaporated.
- active mobile phones in the vicinity of the cd player may cause malfunctions.
- avoid dropping the unit as this may cause damage.

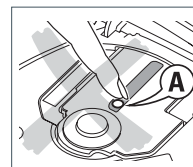

in-car use (connections supplied or optionally available)

only use the AY 3545 or AY 3548 car voltage converter (4.5 V DC, positive pole to the centre pin) and the AY 3501 car cassette adapter. any other product may damage the set.

- 1 put the set on a horizontal, vibration-free and stable surface. make sure it is in a safe place, where the set is neither a danger nor an obstacle to the driver and the passengers.
 - 2 plug the voltage converter into the cigarette lighter socket (**only for 12 V car battery, negative grounding**), then connect the wired end with 4.5V DC input socket on the set.
 - 3 if necessary, clean the cigarette lighter socket to obtain a good electrical contact.
 - 4 turn down the volume and connect the cassette adapter plug to  on the set.
 - 5 carefully insert the cassette adapter into the car radio's cassette compartment.
 - 6 make sure the cord does not hinder your driving.
 - 7 decrease the volume on the set if necessary. start playback on the set and adjust the sound with the car radio controls.
- **always remove the voltage converter from the cigarette lighter socket when the set is not in use.**

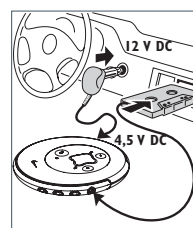







notes: if your car radio has a LINE IN socket, it is better to use it for the car radio connection instead of the cassette adapter. connect the signal lead to this LINE IN socket and to  on the set.

INSTRUCTION FOR USE

cd play / features

playing a cd

this cd-player can play all kinds of **audio discs** such as cd-recordables and cd-rewritables. do not try to play a cd-rom, CDi, VCD, DVD or computer cd.

- 1 push the  slider to open the player.
- 2 insert an audio cd, printed side up, by pressing the cd onto the hub.
- 3 close the player by pressing the lid down.
- 4 press  to switch the player on and start playback.
 - the current track number and elapsed playing time are displayed. indicator lights up green.
- you can pause playback by pressing .
 - the time at which playback was paused starts flashing. indicator turns orange and flashes.
- you can continue playback by pressing  again.
- 5 press  to stop playback.
 - the total number of tracks and the total playing time of the cd are displayed.
- 6 press  again to switch the player off. indicator lights up red and gradually turns off.
- to remove the cd, hold it by its edge and press the hub gently while lifting the cd.

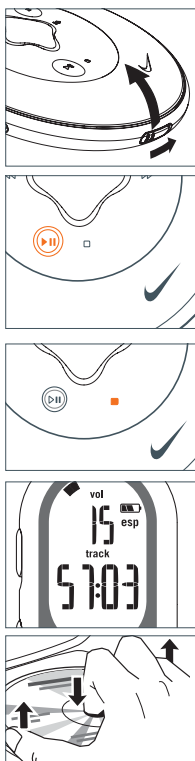

note: if there is no activity, the set will automatically switch off after a while to save energy.



features



selecting a track and searching

selecting a track during playback

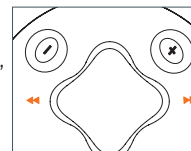

- briefly press  or  once or several times to skip to the current, previous or next track.
 - playback continues with the selected track, and the track's number is displayed.



selecting a track when playback is stopped

- 1 briefly press  or  once or several times to select the desired track. the track number is displayed.
- 2 press  to start cd play.
 - playback starts with the selected track.



searching for a passage during playback

- 1 keep  or  pressed to find a particular passage in a backward or forward direction.
 - searching starts while playback continues at low volume. after 2 seconds the search speeds up.
- 2 release the button when you reach the desired passage.
 - playback continues from this position.

notes:

- if the player is in  mode (see mode chapter), searching is not possible.
- in **shuffle**, **shuffle repeat** or **repeat** mode (see mode chapter), searching is only possible within the particular track.

playback information

- if a cd-recordable (CD-R) or a cd-rewritable (CD-RW) is not recorded properly,  is displayed, indicating that the cd has not been finalized. in that case, use FINALIZE on your cd recorder to complete the recording.
- when playing a cd-rewritable (CD-RW), please note that it takes 3-15 seconds after pressing  for sound reproduction to start.
- playback will stop if you open the cd lid.
- while the cd is read,  flashes in the display.





volume and bass

volume adjustment

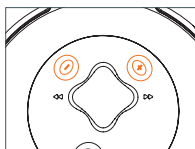
- adjust the volume by using  /  (vol).



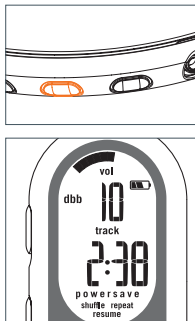

bass adjustment

- press  (on the set only) to switch the bass enhancement on or off
 -  is shown if the bass enhancement is activated.



selecting different playing possibilities-mode

it is possible to play tracks in random order, to repeat a single track or the entire cd, and to play the first few seconds of each track.

- 1 press  during playback as often as required in order to activate one of the following 'modes'. the active mode is shown in the display.
 - **shuffle** : all tracks of the cd are played in random order until all of them have been played once.
 - **shuffle repeat**: all tracks of the cd are played repeatedly in random order.
 - **repeat**: the entire cd is played repeatedly.
 -  : the first 10 seconds of each of the remaining tracks are played in sequence.

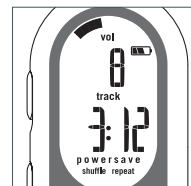
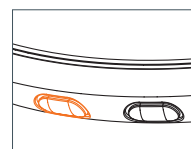

- 2 playback starts in the chosen mode after 2 seconds.
- to return to normal playback, press  repeatedly until the display shows no active modes.

INSTRUCTION FOR USE

features

esp / power save mode

with a conventional portable cd-player you might have experienced that the music stopped e.g. when you were jogging. the **electronic skip protection (esp)** prevents loss of sound caused by light vibrations and shocks. continuous playback is ensured. however esp does not prevent playback interruptions during vigorous running. it also does not protect the unit against any damage caused by dropping! on this set powersaving is default on. the power save mode helps to extend battery lifetime for longer playback.

- press **esp** (on the set only) to enter power save mode.
→ **powersave** is displayed.
- press **esp** again to return to **esp** mode.
→ **powersave** disappears.

esp on → **power save** → **esp on**

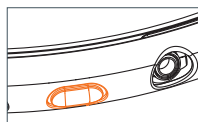

resume and hold

you can interrupt playback and continue (even after an extended period of time) from the position where playback stopped (resume) and you can lock all buttons of the set so that no action will be executed (hold). use the off-resume-hold slider for these functions.

resume – continuing from where you have stopped

- switch the slider to resume during playback to activate resume.
→ **resume** is shown.
 - press **■** whenever you want to stop playback.
 - press **▶||** whenever you want to resume playback.
→ **resume** is shown and playback continues from where you have stopped.
- to deactivate resume, switch the slider to off.
→ **resume** goes off.

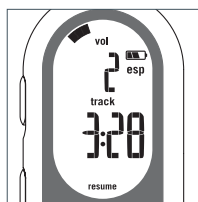
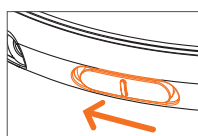
**hold – locking all buttons**

you can lock the buttons of the set by switching the slider to hold. now, when a key is pressed, no action will be executed. this is of use, for example, when transporting the player in a bag. with hold activated, you can avoid accidental activation of other functions.

- switch the slider to hold (or switch hold on the remote control) to activate hold.
→ all buttons are locked **Hold** is shown when you press any button. indicator turns red and flashes. if the set is switched off, **Hold** will be shown only when **▶||** is pressed.
- to deactivate hold, switch the slider to off. (or switch hold on the remote control)

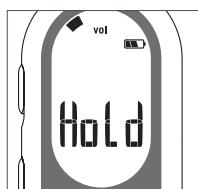

note: if you deactivate hold by switching the slider to resume, you will be activating the resume function.

troubleshooting

troubleshooting

warning: under no circumstances should you try to repair the set yourself as this will invalidate the guarantee. if a fault occurs, first check the points listed, before taking the unit for repair. if you are unable to solve a problem by following these hints, consult your dealer or service centre.

the cd player has no power, or playback does not start

- check that your batteries are not dead or empty, that they are inserted correctly, that the contact pins are clean.
- your adapter connection may be loose. connect it securely.
- for in-car use, check that the car ignition is on. also check player's batteries.

the indication no disc is displayed

- check that the cd is clean and correctly inserted (label-side upward).
- if your lens has steamed up, wait a few minutes for this to clear.

the indication of disc is displayed

- CD-RW (CD-R) was not recorded properly. use FINALIZE on your cd-recorder.

the indication Hold is on and/or there is no reaction to controls

- if hold is activated, then deactivate it.
- electrostatic discharge. disconnect power or remove batteries for a few seconds.

the cd skips tracks

- the cd is damaged or dirty. replace or clean the cd.
- resume, shuffle is active. switch off whichever is on.

troubleshooting

no sound or bad sound quality.

- pause might be active. press **▶||**.
- loose, wrong or dirty connections. check and clean connections.
- volume might not be appropriately adjusted. adjust the volume.
- strong magnetic fields. check player's position and connections. also keep away from active mobile phones.
- for in-car use, check that the cassette adapter is inserted correctly, that the car cassette player's playback direction is correct (press autoreverse to change), and that the cigarette lighter socket is clean. allow time for temperature change.

IMPORTANT

modifications not authorized by the manufacturer may void users authority to operate this device.

SAFETY & WARNINGS

Ⓒ WARNING

All ICs and many other semiconductors are susceptible to electrostatic discharges (ESD). Careless handling during repair can reduce life drastically.

When repairing, make sure that you are connected with the same potential as the mass of the set via a wristband with resistance. Keep components and tools at this potential.

Ⓕ ATTENTION

Tous les IC et beaucoup d'autres semi-conducteurs sont sensibles aux décharges statiques (ESD). Leur longévité pourrait être considérablement écourtée par le fait qu'aucune précaution n'est prise à leur manipulation.

Lors de réparations, s'assurer de bien être relié au même potentiel que la masse de l'appareil et enfilez le bracelet sert d'une résistance de sécurité.

Veiller à ce que les composants ainsi que les outils que l'on utilise soient également à ce potentiel.

ESD



Ⓓ WARNING

Alle ICs und viele andere Halbleiter sind empfindlich gegenüber elektrostatischen Entladungen (ESD). Unvorsichtige Behandlung im Reparaturfall kann die Lebensdauer drastisch reduzieren.

Sorgen Sie dafür, daß Sie im Reparaturfall über ein Pulsarmband mit Widerstand mit dem Massepotential des Gerätes verbunden sind.

Halten Sie Bauteile und Hilfsmittel ebenfalls auf diesem Potential.

Ⓖ WAARSCHUWING

Alle IC's en vele andere halfgeleiders zijn gevoelig voor electrostatische ontladingen (ESD).

Onzorgvuldig behandelen tijdens reparatie kan de levensduur drastisch doen verminderen. Zorg ervoor dat u tijdens reparatie via een polsband met weerstand verbonden bent met hetzelfde potentiaal als de massa van het apparaat.

Houd componenten en hulpmiddelen ook op ditzelfde potentiaal.

Ⓘ AVVERTIMENTO

Tutti IC e parecchi semi-conduttori sono sensibili alle scariche statiche (ESD).

La loro longevità potrebbe essere fortemente ridotta in caso di non osservazione della più grande cautela alla loro manipolazione. Durante le riparazioni occorre quindi essere collegato allo stesso potenziale che quello della massa del apparecchio tramite un braccialetto a resistenza.

Assicurarsi che i componenti e anche gli utensili con quali si lavora siano anche a questo potenziale.

Ⓒ AVAILABLE ESD PROTECTION EQUIPMENT :

anti-static table mat	large 1200x650x1.25mm	4822 466 10953
	small 600x650x1.25mm	4822 466 10958
anti-static wristband		4822 395 10223
connection box	(3 press stud connections, 1MΩ)	4822 320 11307
extendible cable	(2m, 2MΩ, to connect wristband to connection box)	4822 320 11305
connecting cable	(3m, 2MΩ, to connect table mat to connection box)	4822 320 11306
earth cable	(1MΩ, to connect any product to mat or to connection box)	4822 320 11308
KIT ESD3	(combining all 6 prior products - small table mat)	4822 310 10671
wristband tester		4822 344 13999

Ⓒ

Safety regulations require that the set be restored to its original condition and that parts which are identical with those specified be used.

Safety components are marked by the symbol 

Ⓕ

Les normes de sécurité exigent que l'appareil soit remis à l'état d'origine et que soient utilisées les pièces de rechange identiques à celles spécifiées.

Les composants de sécurité sont marqués 

SAFETY



Ⓓ

Bei jeder Reparatur sind die geltenden Sicherheitsvorschriften zu beachten. Der Originalzustand des Gerätes darf nicht verändert werden. Für Reparaturen sind Originalersatzteile zu verwenden.

Sicherheitsbauteile sind durch das Symbol  markiert.

Ⓖ

Veiligheidsbepalingen vereisen, dat het apparaat in zijn oorspronkelijke toestand wordt teruggebracht en dat onderdelen, identiek aan de gespecificeerde, worden toegepast. De Veiligheidsonderdelen zijn aangeduid met het symbool 

Ⓘ

Le norme di sicurezza estigono che l'apparecchio venga rimesso nelle condizioni originali e che siano utilizzati i pezzi di ricambio identici a quelli specificati.

Componenti di sicurezza sono marcati con 

Ⓒ

DANGER: Invisible laser radiation when open. AVOID DIRECT EXPOSURE TO BEAM.



Ⓔ Warning !

Osynlig laserstråling når apparaten är öppnad och spåren är urkopplad. Betrakta ej strålen.

ⒹK Advarsel !

Usynlig laserstråling ved åbning når sikkerhedsafbrydere er ude af funktion. Undgå udsættelse for stråling.

Ⓕ Varoitus !

Avatussa laitteessa ja suojalukituksen ohitettaessa olet alttiina näkymättömälle laserisäteilylle. Älä katso säteeseen !

Ⓒ

After servicing and before returning the set to customer perform a leakage current measurement test from all exposed metal parts to earth ground, to assure no shock hazard exists.

The leakage current must not exceed 0.5mA.

Ⓕ

"Pour votre sécurité, ces documents doivent être utilisés par des spécialistes agréés, seuls habilités à réparer votre appareil en panne".

SERVICE HINTS

REPAIR POSITION COPPERSIDE



To get access to the copperside of the printed board assembly proceed as follows:

1. Remove bottom screws 2pcs (under the plate-decoration)
Remove screws 4pcs (in the CD-door)
2. Lift the bottom-cabinet
3. Supply the unit via external DC-socket
4. Take care that the door switch is closed during measurements

REPAIR POSITION COMPONENTSIDE



To get access to the compomentside of the printed board assembly proceed as follows:

1. Remove bottom screws 2pcs (under the plate-decoration)
Remove screws 4pcs (in the CD-door)
2. Lift the bottom-cabinet
3. Remove screws 2pcs (on the PCB board)
4. Take care that the door switch is closed during measurements

DISMANTLING THE CD-DOOR

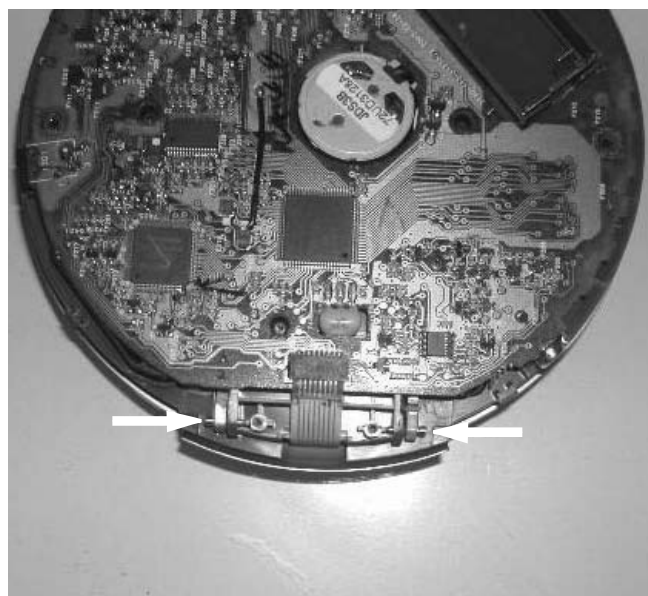

To dismantle the CD-door proceed as follows:

1. Dismantle bottom board
2. Remove screw 2pcs as indicated in the picture above
3. Disconnect the membrane keyboard
4. Dismantle the CD-door carefully

HANDLING CHIP COMPONENTS

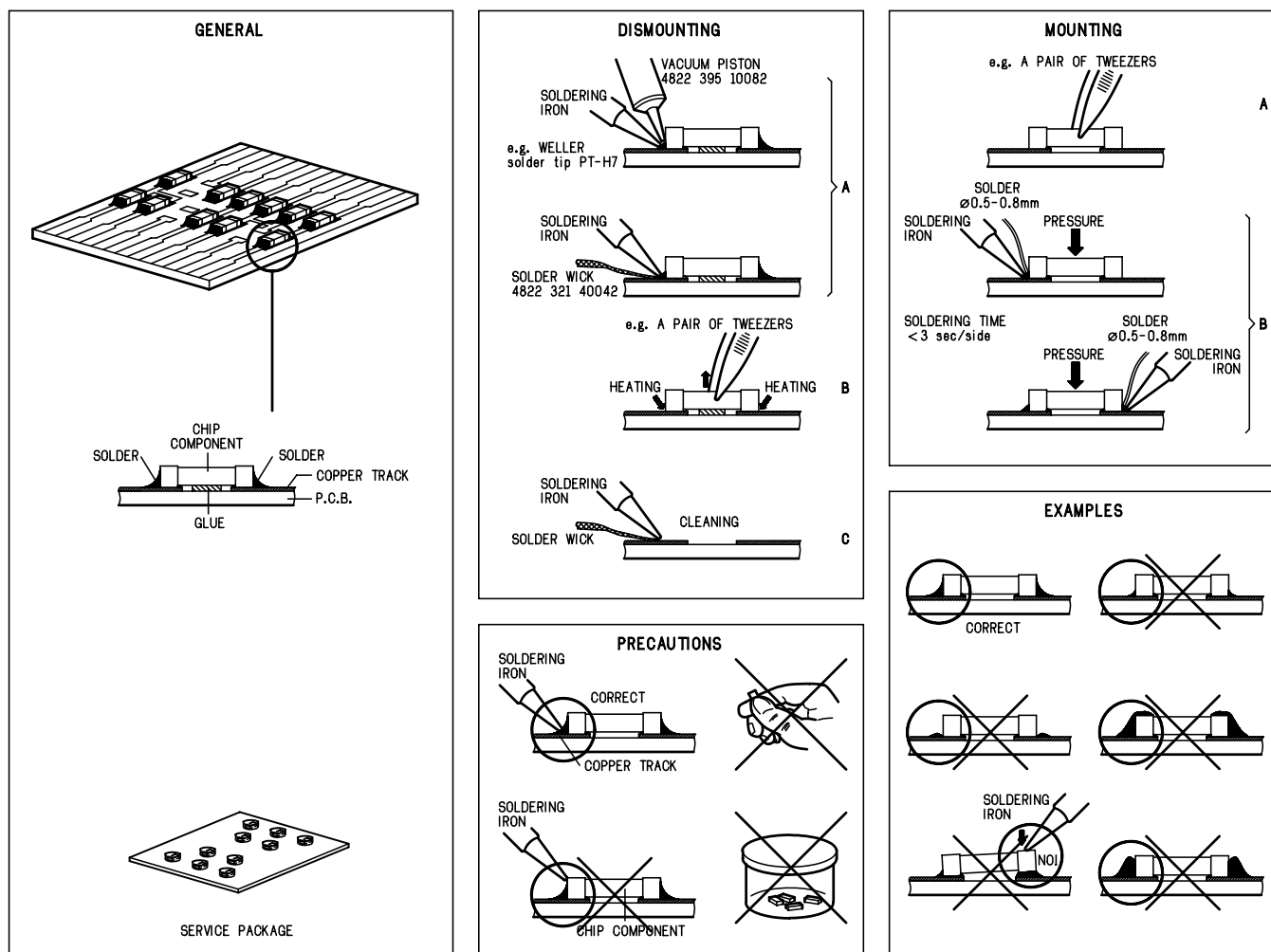

SERVICE TOOLS

Audio signal disc **SBC429**

Playability test disc **SBC444**

Test disc **5** (disc without errors) + Test disc **5A** (disc with dropout errors
black spots and fingerprints) **SBC426/ SBC426A**

4822 397 30184

4822 397 30245

4822 397 30096

ESD PROTECTION EQUIPMENT

Anti-static table mat large 1200x650x1.25mm

small 600x650x1.25mm

4822 466 10953

4822 466 10958

Anti-static wristband

4822 395 10223

Connection box (3press stud connections, 1MΩ)

4822 320 11307

Extendible cable (2m, 2MΩ, to connect wristband to connection box)

4822 320 11305

Connecting cable (3m, 2MΩ, to connect table mat to connection box)

4822 320 11306

Earth cable (1MΩ, to connect any product to mat or to connection box)

4822 320 11308

KIT ESD3 (combining all 6 prior products - small table mat)

4822 310 10671

Wristband tester

4822 344 13999

PIN DESCRIPTIONS OF IC

MCU MN101C39C_399

Name	No.	I/O	Other Function	Function	Description
V _{SS} V _{DD}	11 8			Power supply pin	Supply 2.0 V to 5.5 V to V _{DD} and 0 V to V _{SS} .
OSC1 OSC2	10 9	Input Output		Clock input pin Clock output pin	Connect these oscillation pins to ceramic or crystal oscillators for high-frequency clock operation. If the clock is an external input, connect it to OSC1 and leave OSC2 open. The chip will not operate with an external clock when using either the STOP or SLOW modes.
XI XO	12 13	Input Output		Clock input pin Clock output pin	Connect these oscillation pins to crystal oscillators for low-frequency clock operation. If the clock is an external input, connect it to XI and leave XO open. The chip will not operate with an external clock when using the STOP mode. If these pins are not used, connect XI to V _{SS} and leave XO open.
NRST	32	Input	P27	Reset pin [Active low]	This pin resets the chip when power is turned on, is allocated as P27 and contains an internal pull-up resistor (Typ.35 kW). Setting this pin low initializes the internal state of the device. Thereafter, setting the input to high releases the reset. The hardware waits for the system clock to stabilize, then processes the reset interrupt. Also, if "0" is written to P27 and the reset is initiated by software, a low level will be output. The output has an N-ch open-drain configuration. If a capacitor is to be inserted between NRST and V _{SS} , it is recommended that a discharge diode be placed between NRST and V _{DD} .
P00 P01 P02 P03 P04 P05 P06	25 26 27 28 29 30 31	I/O	SBO0, TXD SBI0, RXD SBT0 SBO1 SBI1 SBT1 NDK, BUZZER	I/O port 0	7-bit CMOS tri-state I/O port. Each bit can be set individually as either an input or output by the P0DIR register. A pull-up resistor for each bit can be selected individually by the P0PLU register. At reset, the input mode is selected and pull-up resistors are disabled (high impedance output).
P10 P11 P12 P13 P14	33 34 35 36 37	I/O	RMOUT TM2IO TM3IO TM4IO	I/O port 1	5-bit CMOS tri-state I/O port. Each bit can be set individually as either an input or output by the P1DIR register. A pull-up resistor for each bit can be selected individually by the P1PLU register. At reset, the input mode is selected and pull-up resistors are disabled (high impedance output).

PIN DESCRIPTIONS OF IC

MCU MN101C39C_399

Name	No.	I/O	Other Function	Function	Description
P20 P21 P22 P23	38 39 40 41	Input	IRQ0 IRQ1, SENS IRQ2 IRQ3	Input port 2	4-bit input port. A pull-up resistor for each bit can be selected individually by the P2PLU register. At reset, pull-up resistors are disabled.
P27	32	Input	NRST	Input port 2	P27 has an n-channel open-drain configuration. When "0" is written and the reset is initiated by software, a low level will be output.
P40 P41 P42 P43 P44 P45 P46 P47	42 43 44 45 46 47 48 49	I/O	KEY0 KEY1 KEY2 KEY3 KEY4 KEY5 KEY6 KEY7	I/O port 4	8-bit CMOS tri-state I/O port. Each bit can be set individually as either an input or output by the P4DIR register. A pull-up resistor for each bit can be selected individually by the P4PLU register. At reset, the input mode is selected and pull-up resistors are disabled (high impedance output).
P50 P51 P52 P53 P54	50 51 52 53 54	I/O	NWE, LED0 NRE, LED1 NCS, LED2 A16, LED3, SEG27 A17, LED4, SEG26	I/O port 5	5-bit CMOS tri-state I/O port. Each bit can be set individually as either an input or output by the P5DIR register. A pull-up resistor for each bit can be selected individually by the P5PLU register. At reset, when single chip mode is selected, the input mode is selected and pull-up resistors for P50 to P54 are disabled (high impedance output). When output mode is selected, P50 to P54 can be used for LED direct drive, and P53 and P54 can be used for segment drive.
P60 P61 P62 P63 P64 P65 P66 P67	55 56 57 58 59 60 61 62	I/O	A0, SEG25 A1, SEG24 A2, SEG23 A3, SEG22 A4, SEG21 A5, SEG20 A6, SEG19 A7, SEG18	I/O port 6	8-bit CMOS tri-state I/O port. Each bit can be set individually as either an input or output by the P6DIR register. A pull-up resistor for each bit can be selected individually by the P6PLU register. At reset, when single chip mode is selected, the input mode is selected and pull-up resistors for P60 to P67 are disabled (high impedance output). When output mode is selected, these pins can be used for segment drive.
P70 P71 P72 P73 P73 P75 P76 P77	63 64 65 66 67 68 69 70	I/O	A8, SDO0, SEG17 A9, SDO1, SEG16 A10, SDO2, SEG15 A11, SDO3, SEG14 A12, SDO4, SEG13 A13, SDO5, SEG12 A14, SDO6, SEG11 A15, SDO7, SEG10	I/O port 7	8-bit CMOS tri-state I/O port. Each bit can be set individually as either an input or output by the P7DIR register. A pull-up or pull-down resistor for each bit can be selected individually by the P7PLUD register. However, pull-up and pull-down resistors cannot be mixed. This port have a synchronous output function for external 2 interrupt, timer 1 interrupt, timer 2 interrupt and timer 4 interrupt. At reset, when single-chip mode is selected, the input mode is selected and pull-up resistors for P70 to P77 are disabled (high impedance output). When output mode is selected, these pins can be used for segment drive.

PIN DESCRIPTIONS OF IC

MCU MN101C39C_399

Name	No.	I/O	Other Function	Function	Description
P80 P81 P82 P83 P84 P85 P86 P87	78 77 76 75 74 73 72 71	I/O	D0, SEG2 D1, SEG3 D2, SEG4 D3, SEG5 D4, SEG6 D5, SEG7 D6, SEG8 D7, SEG9	I/O port 8	8-bit CMOS tri-state I/O port. Each individual bit can be switched to an input or output by the P8DIR register. A pull-up resistor for each bit can be selected individually by the P8PLU register. At reset, when single-chip mode is selected, the input mode is selected and pull-up resistors for P80 to P87 are disabled (high impedance output). When configured as outputs, these pins can drive segments.
PA0 PA1 PA2 PA3 PA4 PA5 PA6 PA7	16 17 18 19 20 21 22 23	Input	AN0 AN1 AN2 AN3 AN4 AN5 AN6 AN7	Input port A	8-bit input port. A pull-up or pull-down resistor for each bit can be selected individually by the PAPLUD resistor. However, pull-up and pull-down resistors cannot be mixed. At reset, the PA0 to PA7 input mode is selected and pull-up resistors are disabled.
SBO0 SBO1	25 28	Output	P00, TXD P03	Serial interface transmission data output pins	Transmission data input pins for serial interfaces 0 to 1. The output configuration, either CMOS push-pull or n-channel open-drain can be selected. Pull-up resistors can be selected by the P0PLU register. Select output mode by the P0DIR register and serial data output mode by serial mode register (SC0MD3 and SC1MD1). These can be used as normal I/O pins when the serial interface is not used.
SBI0 SBI1	26 29	Input	P01, RXD P04	Serial interface reception data input pins	Receive data input pins for serial interfaces 0 to 1. Pull-up resistors can be selected by the P0PLU register. Select input mode by the P0DIR register, and serial input mode by the serial mode register (SC0MD3 and SC1MD1). These can be used as normal I/O pins when the serial interface is not used.
SBT0 SBT1	27 30	I/O	P02 P05	Serial interface clock I/O pins	Clock I/O pins for serial interfaces 0 to 1. The output configuration, either CMOS push-pull or n-channel open-drain can be selected. Push-pull resistors can be selected by the P0PLU register. Select clock I/O for each communication mode by the P0DIR register and serial mode register (SC0MD3 and SC1MD1). These can be used as normal I/O pins when the serial interface is not used.

PIN DESCRIPTIONS OF IC

MCU MN101C39C_399

Name	No.	I/O	Other Function	Function	Description
TXD	25	Output	SBO0, P00	UART transmission data output pin	In the serial interface in UART mode, this pin is configured as the transmission data output pin. The output configuration, either CMOS push-pull or n-channel open-drain can be selected. Pull-up resistors can be selected by the P0PLU register. Select output mode by the P0DIR register, and serial data output by serial 0 mode register 3 (SC0MD3). This can be used as normal I/O pin when the serial interface is not used.
RXD	26	Input	SBI0, P01	UART reception data input pin	In the serial interface in UART mode, this pin is configured as the received data input pin. Pull-up resistors can be selected by the P0PLU register. Set this pin to the input mode by the P0DIR register, and to the serial input mode by the serial 0 mode register 3 (SC0MD3). This can be used as normal I/O pin when the serial interface is not used.
TM2IO TM3IO	35 36	I/O	P12 P13	Timer I/O pins	Event counter clock input pins, timer output and PWM signal output pins for 8-bit timers 2 to 3. To use these pins as event clock inputs, configure them as inputs by the P1DIR register. When the pins are used as inputs, pull-up resistors can be specified by the P1PLU register. For timer output, PWM signal output, select the special function pin by the port 1 output mode register (P1OMD) and set to the output mode by the P1DIR register. When not used for timer I/O, these can be used as normal I/O pins.
RMOUT	33	I/O	P10	Remote control transmission signal output pin	Output pin for remote control transmission signal with a carrier signal. For remote control carrier output, select the special function pin by the port 1 output mode register (P1OMD) and set to the output mode by the P1DIR register. Also, set to the remote control carrier output by the remote control carrier output control register (RMCTR). This can be used as a normal I/O pin when remote control is not used.
BUZZER	31	Output	P06, NDK	Buzzer output	Piezoelectric buzzer driver pin. The driving frequency can be selected by the DLYCTR register. Select output mode by the P0DIR register and select P06 buzzer output by the DLYCTR register. When not used for buzzer output, this pin can be used as a normal I/O pin.

PIN DESCRIPTIONS OF IC

MCU MN101C39C_399

Name	No.	I/O	Other Function	Function	Description
TM4IO	37	I/O	P14	Timer I/O pin	Event counter clock input pin, timer output and PWM signal output pin for 16-bit timer 4. To use this pin as event clock input, configure this as input by the P1DIR register. In the input mode, pull-up resistors can be selected by the P1PLU register. For timer output, PWM signal output, select the special function pin by the port 1 output mode register (P1OMD), and set to the output mode by the P1DIR register. When not used for timer I/O, this can be used as normal I/O pin.
SDO0 SDO1 SDO2 SDO3 SDO4 SDO5 SDO6 SDO7	63 64 65 66 67 68 69 70	Output	P70, A8, SEG17 P71, A9, SEG16 P72, A10, SEG15 P73, A11, SEG14 P74, A12, SEG13 P75, A13, SEG12 P76, A14, SEG11 P77, A15, SEG10	Synchronous output pins	8-bit synchronous output pins. Synchronous output for each bit can be selected individually by the synchronous output control register (SYSMD). Set to the output mode by the P1DIR register. When not used for synchronous output, these pins can be used as a normal I/O pins.
V _{REF+} V _{REF-}	24 15	- -		+power supply for A/D converter - power supply for A/D converter	Reference power supply pins for the A/D converter. Normally, the values of V _{REF+} =V _{DD} and V _{REF-} =V _{SS} are used.
AN0 AN1 AN2 AN3 AN4 AN5 AN6 AN7	16 17 18 19 20 21 22 23	Input	PA0 PA1 PA2 PA3 PA4 PA5 PA6 PA7	Analog input pins	Analog input pins for an 8-channel, 10-bit A/D converter. When not used for analog input, these pins can be used as normal input pins.
IRQ0 IRQ1 IRQ2 IRQ3	38 39 40 41	Input	P20 P21, SENS P22 P23	External interrupt input pins	External interrupt input pins. The valid edge for IRQ0 to 3 can be selected through the IRQnICR register. IRQ1 is an external interrupt pin that is able to determine AC zero crossings. When these are not used for interrupts, these can be used as normal input pins.
SENS	39	Input	P21, IRQ1	AC zero-cross detection input pin	An input pin for an AC zero-cross detection circuit. The AC zero-cross detection circuit outputs a high level when the input is at an intermediate level. Otherwise, it outputs a low level voltage all the times. SENS input signal is connected to the P21 input circuit and the IRQ1 interrupt circuit. When the AC zero-cross detection circuit is not used, this pin can be used as a normal P21 input. The selection is set by the P21IM flag of the FLOAT1 register.

PIN DESCRIPTIONS OF IC

MCU MN101C39C_399

Name	No.	I/O	Other Function	Function	Description
KEY0 KEY1 KEY2 KEY3 KEY4 KEY5 KEY6 KEY7	42 43 44 45 46 47 48 49	Input	P40 P41 P42 P43 P44 P45 P46 P47	Key interrupt input pins	Input pins for interrupt based on OR condition of pin inputs. Key input pin for 2 bits can be selected individually by the key interrupt control register (P4IMD). When not used for KEY input, these pins can be used as normal I/O pins.
VLC1 VLC2 VLC3	7 6 5			LCD power supply	These pins supply power to the LCDs. VDD is normally divided by resistors to supply this voltage.
COM0 COM1 COM2 COM3	1 2 3 4	Output		LCD common outputs	These pins output a common signal with the required timing to the LCD display. Also, they may be connected to the common pins on the LCD panel.
LED0 LED1 LED2 LED3 LED4	50 51 52 53 54	Output	P50, NWE P51, NRE P52, NCS P53, A16, SEG27 P54, A17, SEG26	LED (large current) output	LED driving pins.
SEG27 SEG26 SEG25 SEG24 SEG23 SEG22 SEG21 SEG20 SEG19 SEG18 SEG17 SEG16 SEG15 SEG14 SEG13 SEG12 SEG11 SEG10 SEG9 SEG8 SEG7 SEG6 SEG5 SEG4 SEG3 SEG2	53 54 55 56 57 58 59 60 61 62 63 64 65 66 67 68 69 70 71 72 73 74 75 76 77 78	Output	P53, A16, LED3 P54, A17, LED4 P60, A0 P61, A1 P62, A2 P63, A3 P64, A4 P65, A5 P66, A6 P67, A7 P70, A8, SDO0 P71, A9, SDO1 P72, A10, SDO2 P73, A11, SDO3 P74, A12, SDO4 P75, A13, SDO5 P76, A14, SDO6 P77, A15, SDO7 P87, D7 P86, D6 P85, D5 P84, D4 P83, D3 P82, D2 P81, D1 P80, D0	LCD segment output	Connect to segment pins on the LCD panel. These pins are allocated to PORT53, 54, 60 to 67, 70 to 77, 80 to 87. When segments are not used, these pins can be used as normal I/O pins. At reset, all pins are set to the input mode.

PIN DESCRIPTIONS OF IC

MCU MN101C39C_399

Name	No.	I/O	Other Function	Function	Description
SEG1 SEG0	79 80	Output		LCD segment output	Connect to segment pins on the LCD panel.
MMOD	14	Input		Memory mode switch input pin	This pin sets the memory expansion mode. Set this pin always to low.
NWE	50	Output	P50, LED0	Write enable pin (Active low) Read enable pin, LED0 (Active low) Chip select pin (Active low) Data acknowledge pin (Active low) Address pin	Memory control signals for an expanded memory space outside this LSI. NWE is a strobe signal output for writing to external memory. NRE is a strobe signal output for reading from external memory. NCS is a chip select signal output when external memory is accessed. NDK is an acknowledge signal that indicates the external memory access is complete. A0 to A17 are address signals output to external memory.
NRE	51	Output	P51, LED1		
NCS	52	Output	P52, LED2		
NDK	31	Input	P06, BUZZER		
A0	55	Output	P60, SEG25		
A1	56	Output	P61, SEG24		
A2	57	Output	P62, SEG23		
A3	58	Output	P63, SEG22		
A4	59	Output	P64, SEG21		
A5	60	Output	P65, SEG20		
A6	61	Output	P66, SEG19		
A7	62	Output	P67, SEG18		
A8	63	Output	P70, SDO0, SEG17		
A9	64	Output	P71, SDO1, SEG16		
A10	65	Output	P72, SDO2, SEG15		
A11	66	Output	P73, SDO3, SEG14		
A12	67	Output	P74, SDO4, SEG13		
A13	68	Output	P75, SDO5, SEG12		
A14	69	Output	P76, SDO6, SEG11		
A15	70	Output	P77, SDO7, SEG10		
A16	53	Output	P53, SEG27, LED3		
A17	54	Output	P54, SEG26, LED4		
D0	78	I/O	P80, SEG2	Data pin	
D1	77	I/O	P81, SEG3		
D2	76	I/O	P82, SEG4		
D3	75	I/O	P83, SEG5		
D4	74	I/O	P84, SEG6		
D5	73	I/O	P85, SEG7		
D6	72	I/O	P86, SEG8		
D7	71	I/O	P87, SEG9		

BLOCK DIAGRAM OF IC

CD-ESP-DECODER MN662786SB

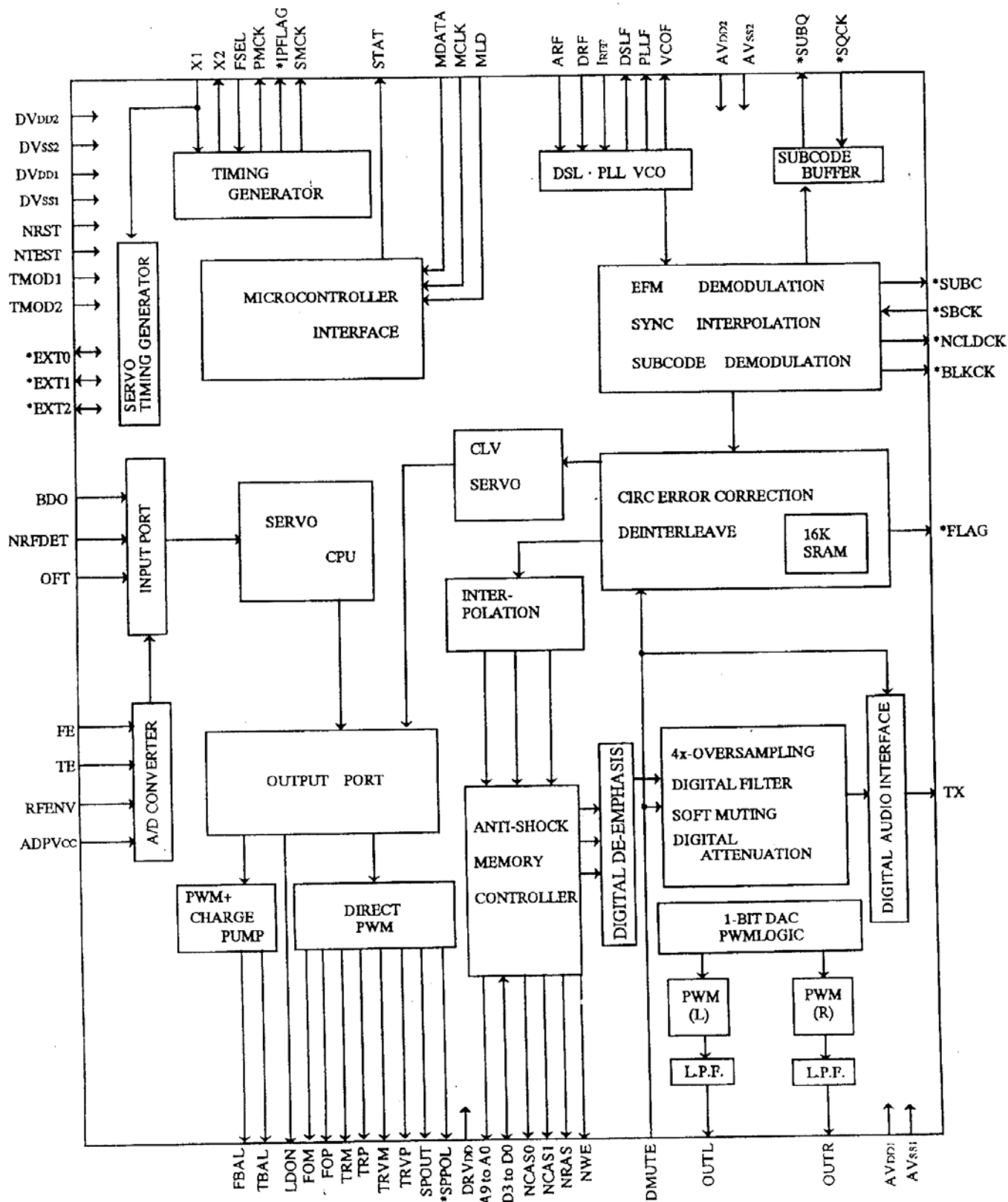

Note) Asterisk-marked pins can be switched to different signals with microcontroller commands.

START-UP PROCEDURE -CHART

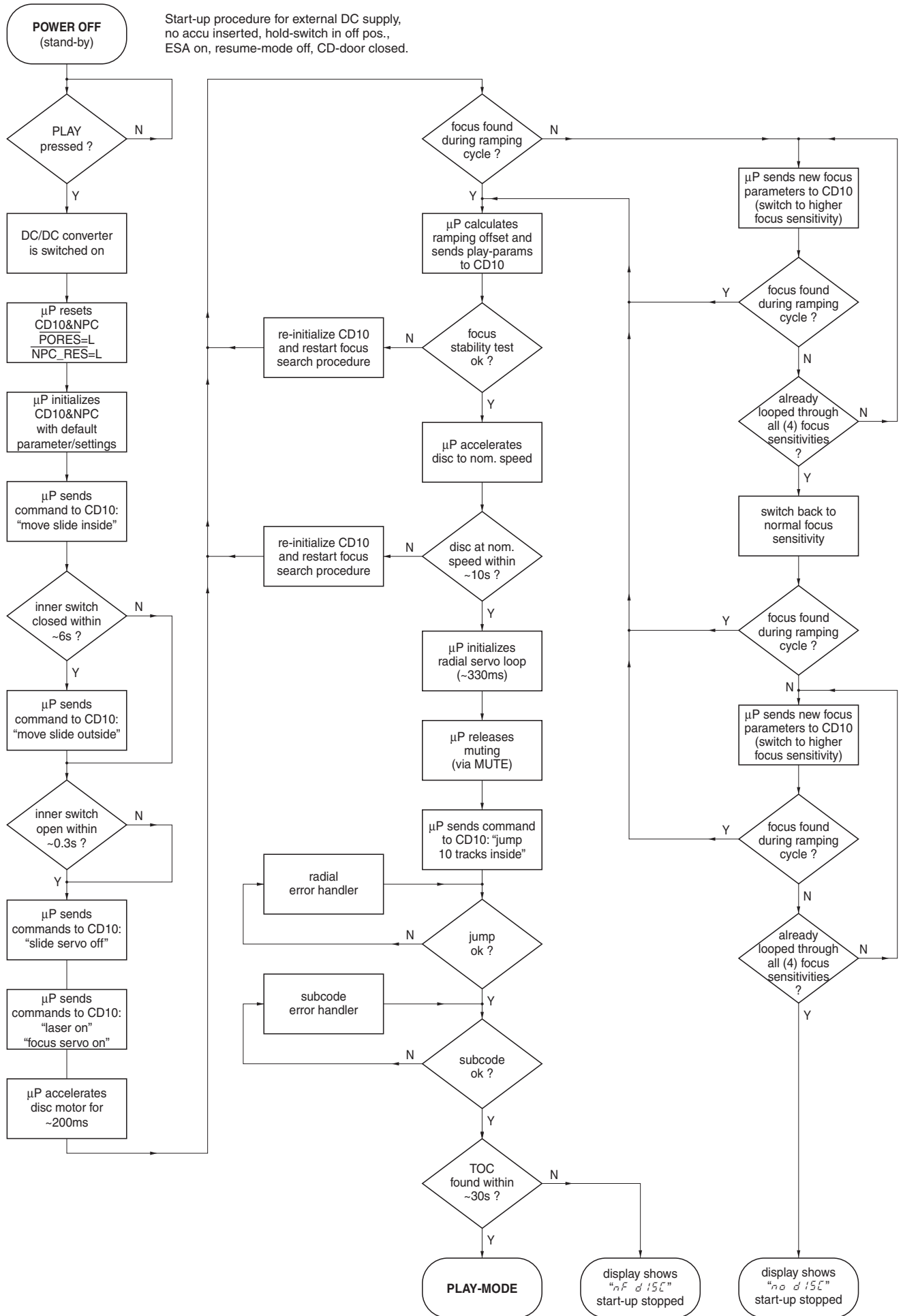

SERVICE TEST PROGRAM

1. PRELIMINARY SETUP

- To enter the service test program disconnect the AC/DC adaptor and remove batteries, open the CD-door and hold the buttons "PLAY" & "MODE" depressed while turning power on (i.e. connecting the AC/DC adaptor).
- The display shows the software version of the built-in μP (i.e. "5-25"). Versions are counted from "0" onwards; that means the higher the number the newer the software.
- The program is now in the main menu – various tests can be entered by pressing the corresponding buttons (see flow chart on next page or detailed description of available tests below).
- To exit the service test program press the "STOP" button or disconnect the set from the power source.

2. DISPLAY TEST

Purpose: Check functionality of display and display driver.

- To enter the display test start the service test program and press the "NEXT" button.
- The display shows test pattern1. All segments are activated for finding open circuits (see flow chart on next page).
- To jump to the next pattern press the "NEXT" button.
- The display shows test pattern2. All alternate pins (2, 4, ...) are activated for finding short circuits (see flow chart on next page).
- To jump back to test pattern1 press the "NEXT" button, to exit the display test and return to the main menu press the "STOP" button.

3. KEY TEST

Purpose: Check operation of keys and cord remote control.

- To enter the key test start the service test program and press the "PREV" button.
- The display shows " - - ".
- Hold key depressed and check corresponding key code on the display. Key codes can be found in table1 (see flow chart on next page).
- To exit the key test and return to the main menu press the "STOP" button.

4. PLAYBACK TEST WITH ERROR ANALYSIS

Purpose: Analyze errors that occur during playback and search for intermittent failures.

- To enter the playback test start the service test program and press the "BASS" button.
- To start the error analysis press the "PLAY" button. Note that the playback test can only be entered if the CD-door is closed.
- The set will read the TOC and start playback.

As long as the playback is free of errors the display shows track and time information like in normal play-mode. In case of errors corresponding error codes will be displayed. The meaning of these error codes can be found in table2 (see flow chart on next page).

Note: Errors can either be "fatal" or "non fatal". Fatal errors always stop the playback, non fatal errors only cause a short interruption of the music. Fatal errors are displayed as long as the set is connected to the power source, non fatal errors are displayed until a new error occurs or a button is pressed.

- To stop the playback test disconnect the set from the power source.

5. SERVO TEST

Purpose: Check door switch, inner switch of CD-drive, movement of slide and acceleration of discmotor.

- To enter the servo test start the service test program and press the "PLAY" button.
- The display shows "x y".
"x" indicates state of door switch;
"y" indicates state of inner switch.
x,y = "0" means switch is closed; "1" means switch is open.
- To move slide outside hold the "NEXT" button depressed.
- To move slide inside hold the "PREV" button depressed.
- To accelerate the discmotor clockwise hold the "MODE" button depressed.
- To accelerate the discmotor counter-clockwise hold the "PROG" button depressed.
- To enter the focus test press the "PLAY" button, to exit the servo test and return to the main menu press the "STOP" button.

6. FOCUS TEST

Purpose: Check movement of lens and operation of focus servo for CDDA and CDRW discs.

Since the CDRW reflects much less light than an ordinary CDDA, the gain of the HF-amplifier stage and the sensitivity of the ADC inside the Decoder&Digital Servo IC "CD10" must be adapted accordingly. The gain is switched via the CDRW input of the HF-preamplifier. The ADC-sensitivity is set via software parameters (sent from μP to "CD10"). In total, there are 4 sensitivity modes available: 1 for CDDA and 3 for CDRW. The modes are listed in table3 (see next page). In normal play-mode, the correct focus sensitivity is chosen automatically during start-up (see "Start-up procedure" on previous page). In the service test program, the sensitivity can be chosen manually in order to allow individual measurements in several modes.

- The focus servo loop is switched on and the set starts searching the focus ("focus ramping"). As soon as the focus has been found the focus servo loop is closed and the state of the focus is monitored continuously.
- If the focus is OK the display shows " F x", else " - F x". "x" indicates the sensitivity mode. Details can be found in table3 (see flow chart on next page).
- To toggle between sensitivity modes press the "BASS" button.
- To move slide outside hold the "NEXT" button depressed.
- To move slide inside hold the "PREV" button depressed.
- To accelerate the discmotor clockwise hold the "MODE" button depressed.
- To accelerate the discmotor counter-clockwise hold the "PROG" button depressed.
- In case the focus is OK the discmotor test can be entered by pressing the "PLAY" button, to exit the focus test and return to the main menu press the "STOP" button.

7. DISCMOTOR TEST

Purpose: Check speed regulation of discmotor.

- The speed regulation is switched on and the discmotor starts rotating. If the speed reaches 75% of the nom. speed the display shows " d", else " - d".
- In parallel also the state of the focus is monitored continuously (display " F x" or " - F x").
- In case the disc speed is OK and the focus is OK the radial test can be entered by pressing the "PLAY" button, to exit the discmotor test and return to the main menu press the "STOP" button.

8. RADIAL TEST

Purpose: Check if radial loop locks and an audio signal is audible at the headphone output.

- The radial servo loop is switched on, mute is released and the audio signal is audible. If the system is on track the display shows " r", else " - r".
- In parallel also the disc speed (display " d" or " - d") and the state of the focus (display " F x" or " - F x") are monitored continuously. Note: In case of radial errors the audio output is muted and muting is not released automatically when the systems recovers from the error. " - r" remains on the display.
To open mute again press the "NEXT" or "PREV" button.
- To jump 16 tracks outside press the "NEXT" button.
- To jump 16 tracks inside press the "PREV" button.
- To exit the radial test and return to the main menu press the "STOP" button, to exit the service test program disconnect the set from the power source.

Important remark:

In radial test mode data to the DRAM is written at 1.2 times the nominal speed, and read from the DRAM at nominal speed. Because writing is done faster than reading the DRAM gets full after a certain time.

In normal play mode the system would now wait until the DRAM is partly emptied again, jump backwards and resume filling at the last written position. However, in radial test mode the jumps would disturb measurements on the radial servo loop. Therefore this function has been disabled and filling restarts immediately from the current position of the pick-up unit. As a result "jumps" are audible during playback.

SERVICE TEST PROGRAM - FLOW CHART

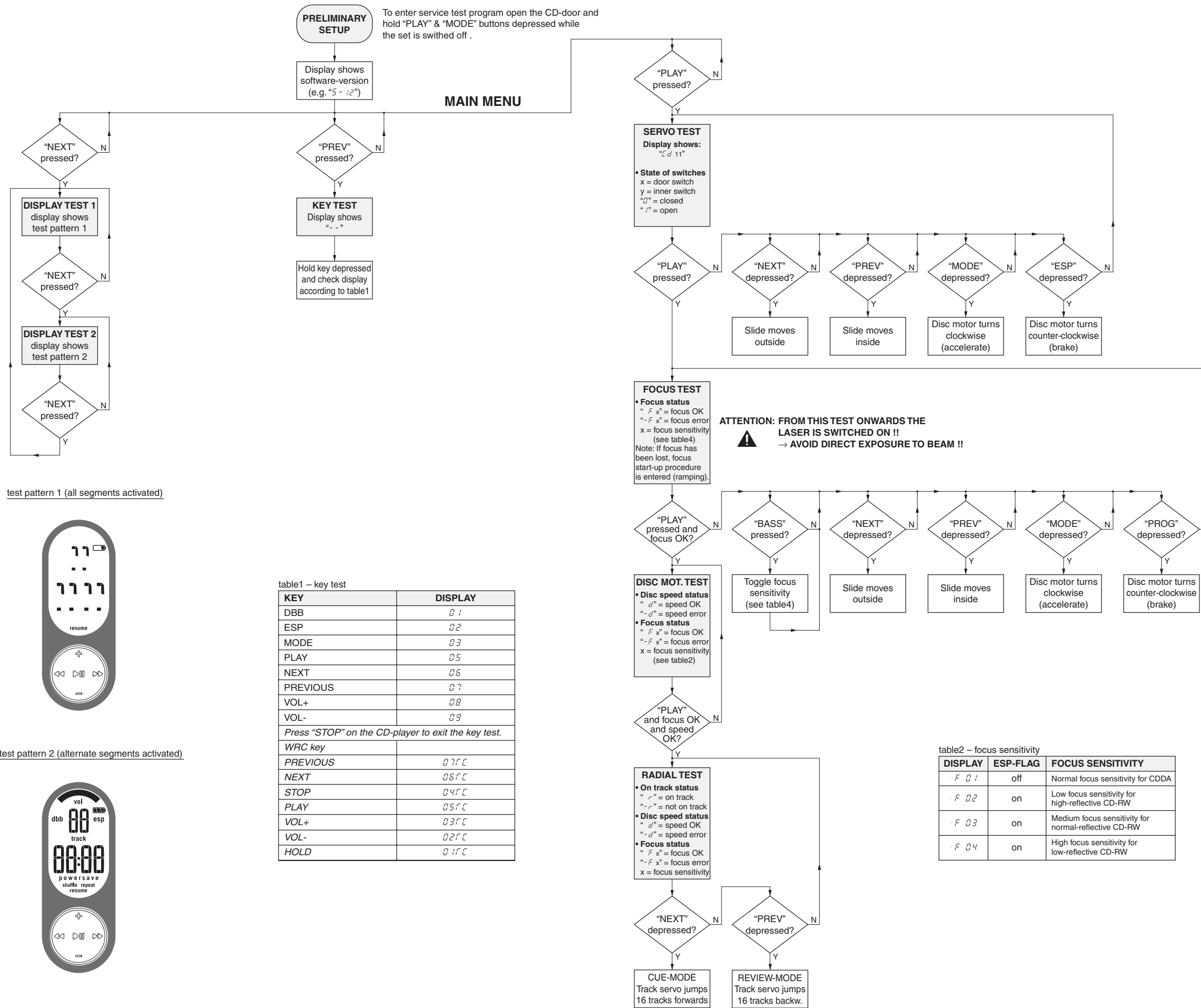

BLOCKDIAGRAM

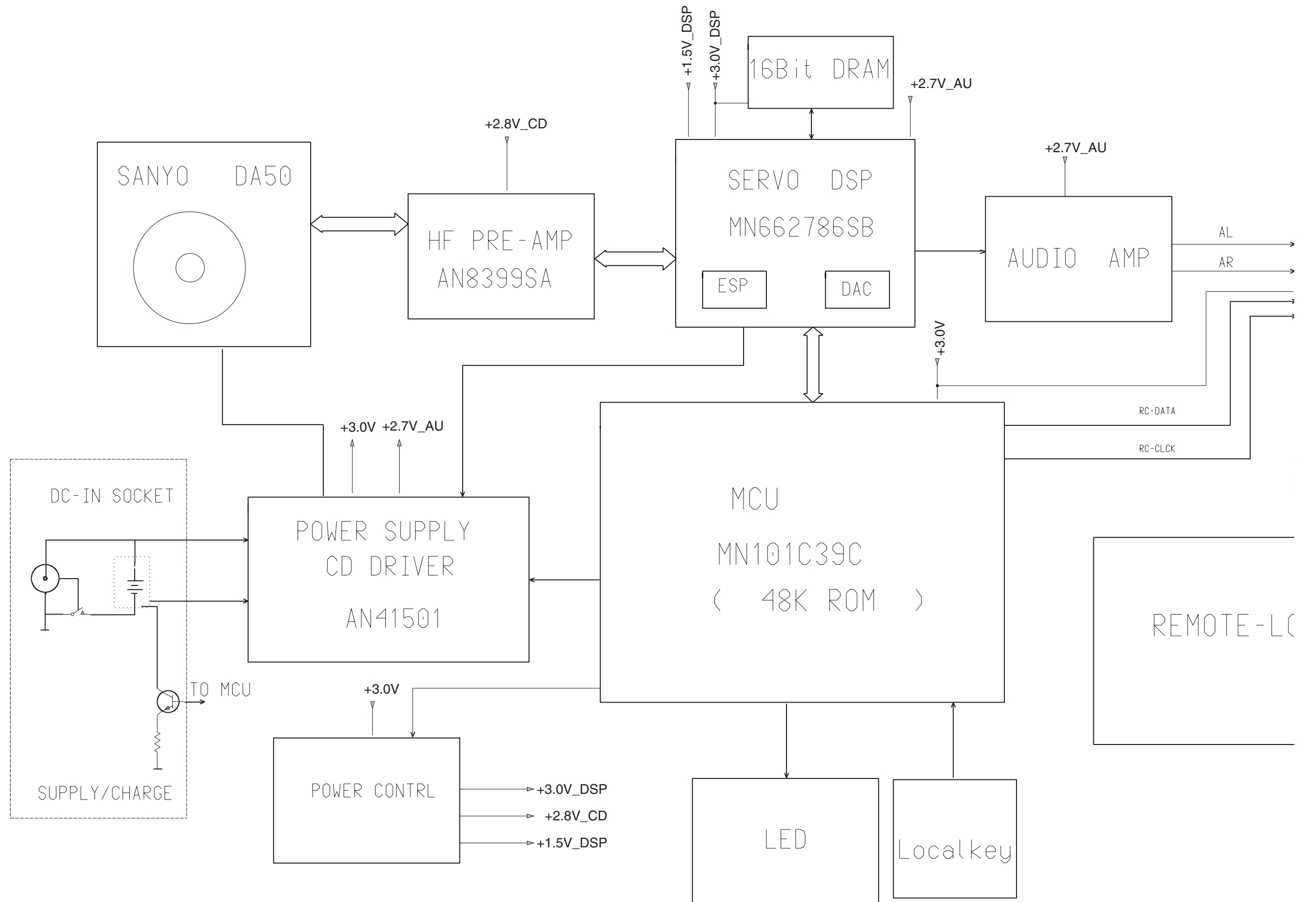

COMBI BOARD - CIRCUIT DIAGRAM CONTROL/SUPPLY PART

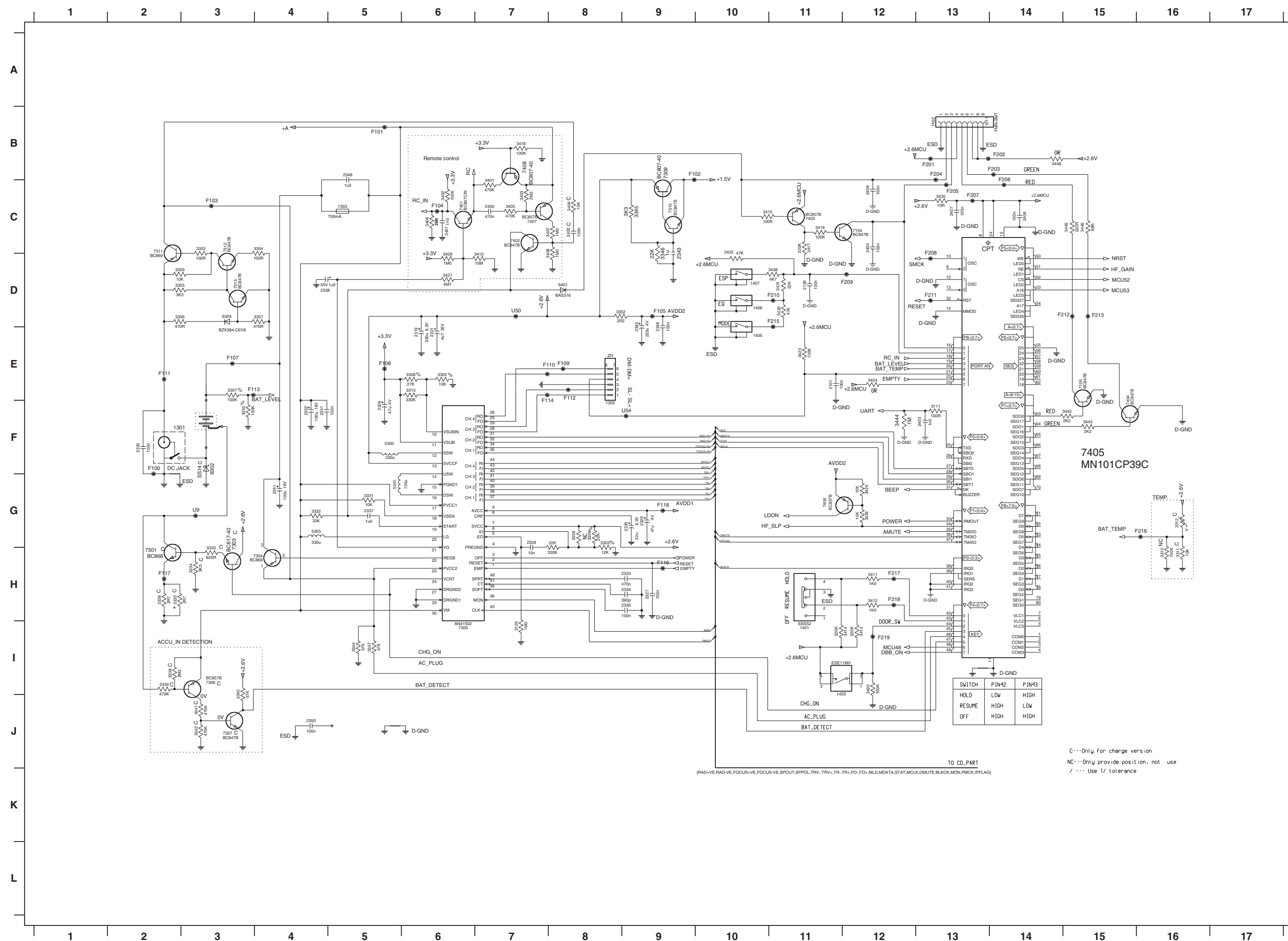

- U9 G3
- U50 D7
- U54 F9
- 1301 F2
- 1302 F8
- 1303 C5
- 1401 I11
- 1402 B13
- 1403 I11
- 1405 E10
- 1406 D10
- 1407 D10
- 2101 E11
- 2126 D11
- 2319 E6
- 2321 E6
- 2326 F5
- 2327 H9
- 2328 G7
- 2329 G9
- 2330 G9
- 2331 F4
- 2332 F4
- 2333 H9
- 2334 H9
- 2335 F2
- 2336 H9
- 2337 G5
- 2338 D4
- 2343 C9
- 2345 D9
- 2346 D9
- 2348 B5
- 2350 J4
- 2351 G4
- 2400 C7
- 2401 C9
- 2402 C8
- 2403 F13
- 2404 C12
- 2406 C14
- 2407 C13
- 2408 C12
- 3111 F13
- 3126 I7
- 3303 G8
- 3304 I5
- 3305 E8
- 3306 H8
- 3307 E3
- 3308 E6
- 3309 C8
- 3310 H16
- 3311 H16
- 3312 G16
- 3313 E5
- 3330 F3
- 3331 G5
- 3332 G4
- 3333 H3
- 3334 H3
- 3335 H2
- 3336 H2
- 3337 I5
- 3338 I2
- 3339 I2
- 3341 J3
- 3342 J3
- 3345 C9
- 3346 D9
- 3352 D8
- 3353 C3
- 3354 C4
- 3355 D2
- 3356 D2
- 3357 D4
- 3358 G8
- 3359 D2
- 3401 C7
- 3402 C6
- 3403 C7
- 3404 C8
- 3405 C7
- 3406 C6
- 3407 C8
- 3408 C8
- 3409 D6
- 3410 D7
- 3411 H12
- 3412 H12
- 3413 H12
- 3414 H12
- 3415 C10
- 3416 C11
- 3417 C11
- 3418 B7
- 3420 H12
- 3423 E11
- 3424 E12
- 3425 G12
- 3426 G12
- 3427 D6
- 3430 D11
- 3431 D11
- 3432 C10
- 3435 C13
- 3438 D11
- 3442 F15
- 3443 F15
- 3444 F12
- 3445 C15
- 3446 C15
- 3448 B14
- 5300 F5
- 5301 G5
- 5303 G4
- 6302 F3
- 6304 D3
- 6401 D8
- 7104 C12
- 7105 E15
- 7300 I6
- 7301 H2
- 7303 H3
- 7304 H4
- 7306 I3
- 7307 J3
- 7309 B9
- 7310 C9
- 7311 C2
- 7312 C3
- 7313 D3
- 7401 C6
- 7402 C7
- 7403 C11
- 7407 C7
- 7408 B7
- F100 F2
- F101 B5
- F102 B9
- F103 C3
- F104 C6
- F105 D9
- F107 E3
- F108 E5
- F109 E8
- F110 E8
- F111 E2
- F112 E8
- F113 E3
- F114 F7
- F116 H6
- F117 H2
- F118 G9
- F201 B13
- F202 B14
- F203 B14
- F204 C13
- F205 C13
- F206 C14
- F207 C13
- F208 D13
- F209 D12
- F210 D11
- F211 D13
- F212 D15
- F213 D15
- F215 D11
- F216 G16
- F217 H12
- F218 H12
- F219 I12

C---Only for charge version
 NC---Only provide position, not use
 /---Use 1/ tolerance

(RAD:VE:RAD-VE.FOCUS+VE.FOCUS-VE.SPOUT.SPPOL.TRV+TRV-TR.FO-FO-MLD.MDATA.STAT.MLK.DMUTE.BLKCK.MON.PACK.IPLAG)

SWITCH	PIN#2	PIN#3
HOLD	LOW	HIGH
RESUME	HIGH	LOW
OFF	HIGH	HIGH

COMBI BOARD - CIRCUIT DIAGRAM DRIVE/EPS PART

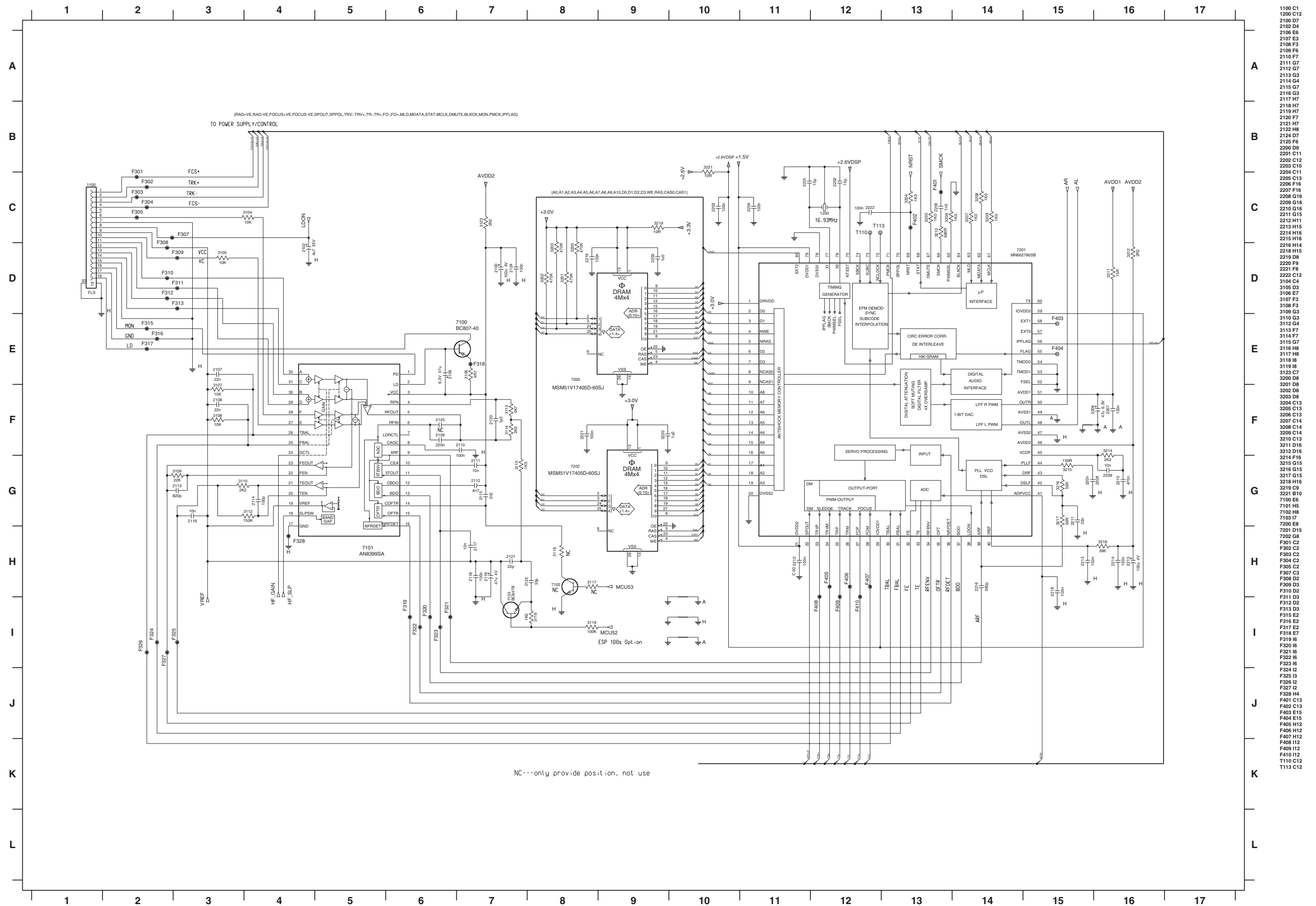

- 1100 C1
- 1200 C12
- 2100 D7
- 2102 G4
- 2106 E6
- 2107 E3
- 2108 F3
- 2109 F6
- 2110 F7
- 2111 G7
- 2112 G7
- 2113 G3
- 2114 G4
- 2115 G7
- 2116 G3
- 2117 H7
- 2118 H7
- 2119 H7
- 2120 F7
- 2121 H7
- 2122 H8
- 2124 D7
- 2125 F6
- 2200 D9
- 2201 C11
- 2202 C12
- 2203 C10
- 2204 C11
- 2205 C13
- 2206 F16
- 2207 F16
- 2208 G16
- 2209 G16
- 2210 G16
- 2211 G15
- 2212 H11
- 2213 H15
- 2214 H16
- 2215 H16
- 2216 H14
- 2218 H15
- 2219 D8
- 2220 F9
- 2221 F8
- 2222 C12
- 3104 C4
- 3105 D3
- 3106 E7
- 3107 F3
- 3108 F3
- 3109 G3
- 3110 E7
- 3112 G4
- 3113 F7
- 3114 F7
- 3115 G7
- 3116 H8
- 3117 H8
- 3118 H8
- 3119 H8
- 3123 C7
- 3200 D8
- 3201 D8
- 3202 D8
- 3203 D8
- 3204 C13
- 3205 C13
- 3206 C13
- 3207 C14
- 3208 C14
- 3209 C14
- 3210 C13
- 3211 D16
- 3212 D16
- 3214 F16
- 3215 E15
- 3216 G15
- 3217 G15
- 3218 H16
- 3219 C9
- 3221 B10
- 7100 E6
- 7101 H5
- 7102 H8
- 7103 F7
- 7200 E8
- 7201 D15
- 7202 O8
- F301 C2
- F302 C2
- F303 C2
- F304 C2
- F305 C2
- F307 C3
- F308 D2
- F309 D3
- F310 D2
- F311 D3
- F312 D2
- F313 D3
- F315 E2
- F316 E2
- F317 E2
- F318 E7
- F319 H6
- F320 H6
- F321 H6
- F322 H6
- F323 H6
- F324 I2
- F325 I3
- F326 I2
- F327 I2
- F328 H4
- F401 C13
- F402 C13
- F403 E15
- F404 E15
- F405 H12
- F406 H12
- F407 H12
- F408 H12
- F409 H12
- F410 H12
- T110 C12
- T113 C12

COMBI BOARD - CIRCUIT DIAGRAM AUDIO PART

1500 C10	2511 B2	2523 C5	2528 C1	2533 D6	2538 A7	3505 B5	3511 B1	3518 C3	3525 C4	3539 C4	3546 C5	3552 D6	3557 B5	4002 D9	7500-A D7	7508 B4	7515 E7	F505 B10	F511 C9
2500 A7	2515 B1	2524 C9	2529 C2	2534 D7	3500 A5	3506 B6	3513 B3	3519 B6	3526 C6	3542 C8	3547 C5	3553 D8	3558 C5	6500 B8	7500-B A7	7510 B7	F501 B6	F506 B4	F512 C2
2501 B8	2516 B2	2525 C4	2530 C10	2535 E8	3501 A4	3507 B8	3514 B4	3521 B4	3530 C8	3543 C1	3548 D5	3554 D8	3559 A6	6501 C9	7501 B9	7511 C7	F502 B2	F507 B6	F513 C9
2502 B6	2520 B5	2526 C8	2531 D7	2536 C5	3502 A5	3508 B8	3515 B7	3522 B3	3534 C3	3544 C1	3549 D8	3555 D7	3560 B10	6502 C10	7503 B3	7512 C4	F503 B9	F508 C7	F514 D6
2503 B7	2522 B9	2527 C2	2532 D8	2537 A7	3503 A8	3510 B1	3517 B9	3524 C7	3535 C6	3545 C9	3551 D4	3556 E8	4001 B9	6503 D5	7506 B6	7513 C9	F504 B10	F510 C10	F515 E7

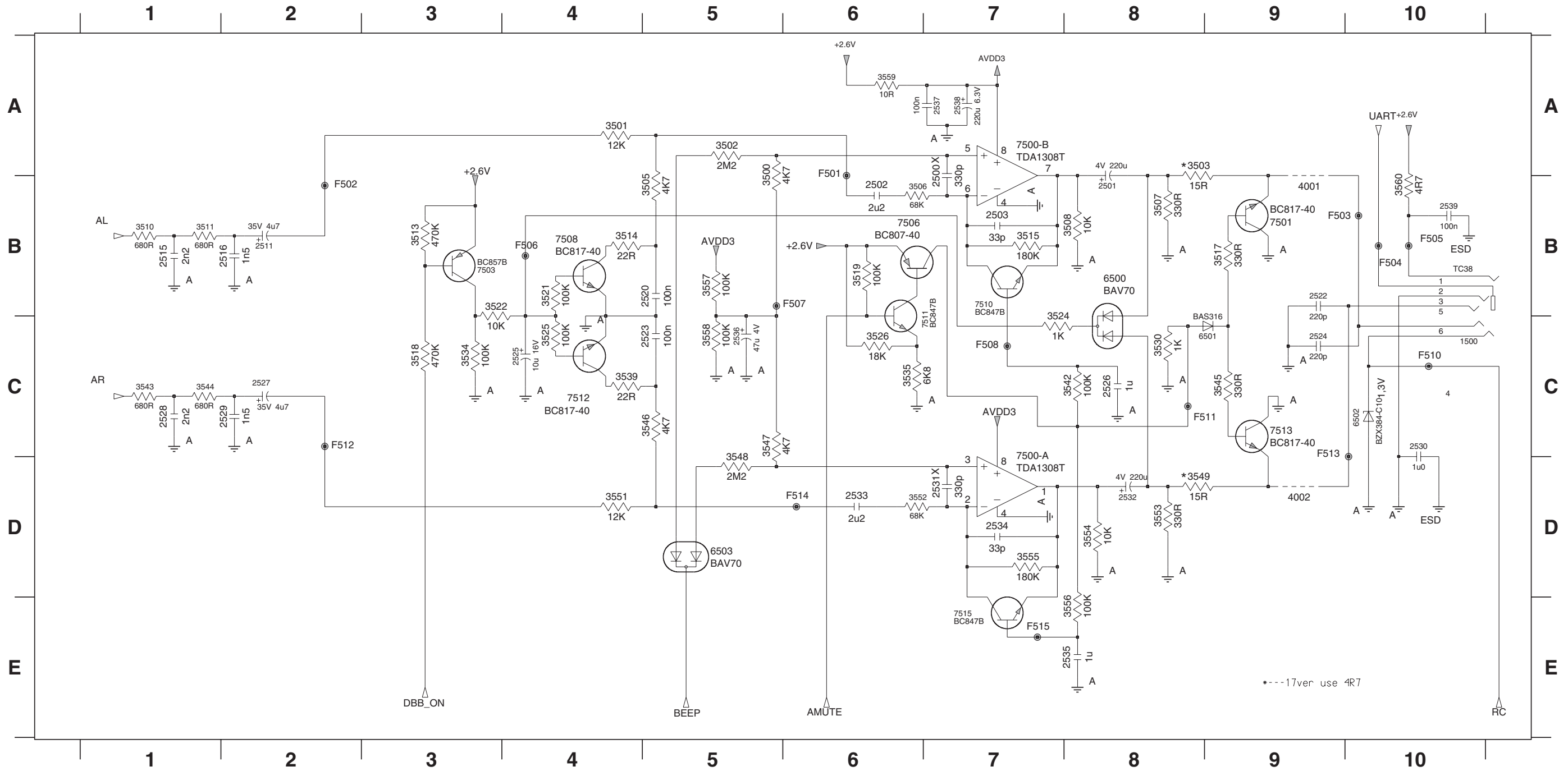

EXPLODED VIEW DIAGRAM

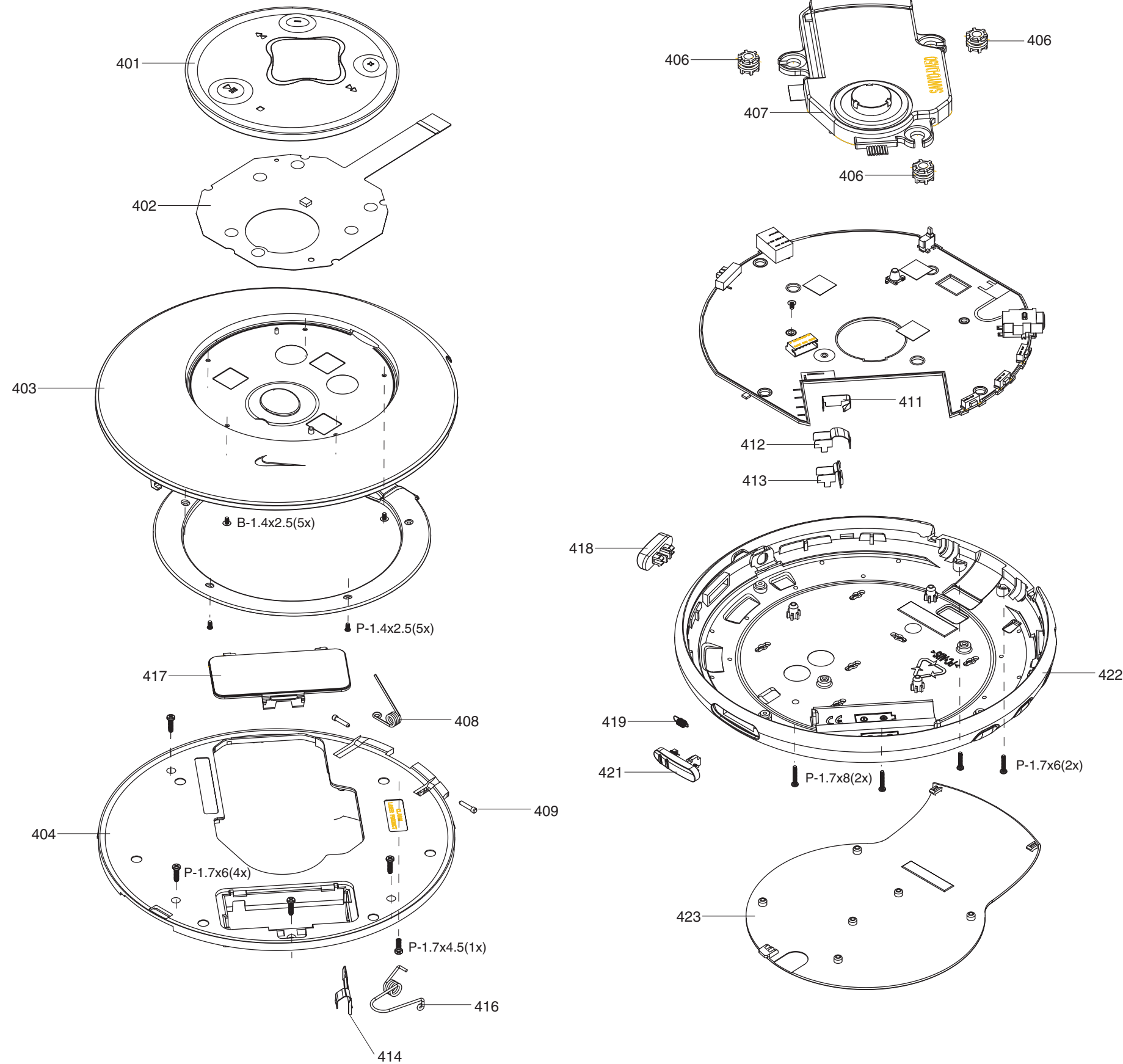

MECHANICAL PARTSLIST

401	3140 117 68581	KEYPAD ASSY ACT500/00C
402	3140 113 33321	MEMBRANE-KEYBOARD ACT500
403	3140 117 68571	DOOR-CD PRE-ASSY ACT500/00C
404	3140 117 68591	CABINET-MIDDLE PRE-ASSY ACT500
406	3140 114 47581	DAMPER-AX5203
407	2422 549 45374	CD DRIVE DA50
408	3140 111 01591	SPRING DOOR-OPEN-2 ACT500
409	3140 111 22891	SHAFT-CD DOOR ACT500
411	3140 111 22941	SPRING-CHARGING ACT500
412	3140 111 22871	SPRING BATTERY MINUS ACT500
413	3140 111 22861	SPRING BATTERY PLUS ACT500
414	3140 111 22881	SPRING BATTERY PLUS-MINUS
416	3140 111 01571	SPRING DOOR-OPEN ACT500
417	3140 117 69181	DOOR-BATTERY PRT ACT500
418	3140 114 60441	SLIDER-HOLD ACT500
419	3140 111 01581	SPRING-SLIDER-LOCK ACT500
421	3140 117 69381	SLIDER-LOCK PNT ACT500
422	3140 117 68601	CABINET-BOTTOM PRE-ASSY ACT500
423	3140 114 60421	BOTTOM PLATE

Note: Only these parts mentioned in the list are normal service parts.

ELECTRICAL PARTSLIST - COMBI BOARD

- MISCELLANEOUS -

1100	2422 025 17486	SOCKET FFC H 18P
1301	2422 026 05086	CONNECTOR SUPPLY
1302	2422 025 12918	CONNECTOR H 6P
1303	2422 086 11012	FUSE 0,7A 50V
1401	4822 277 21705	SWITCH

1402	2422 025 17201	SOCKET FFC H 9P
1403	2422 129 16818	SWITCH-DET 1P
1405	2422 128 02968	SWITCH-TACT
1406	2422 128 02968	SWITCH-TACT
1407	2422 128 02968	SWITCH-TACT

1500	2422 026 05386	SOCKET PHONE H 1P
------	----------------	-------------------

- CAPACITORS -

2100	3198 032 15190	100µF 20% 4V
2101	2238 586 59812	100nF +80-20% Y5V 50V
2102	2020 021 91729	4,7µF 20% 35V
2106	2022 009 00656	47µF 20% 6,3V
2107	2238 916 15641	22nF 10% 25V

2108	2238 916 15641	22nF 10% 25V
2109	4822 126 13879	220nF +80-20% 16V
2110	2238 586 59812	100nF +80-20% Y5V 50V
2111	5322 126 11583	10nF 10% X7R 50V
2112	4822 126 13193	4,7nF 10% X7R 63V

2113	3198 016 38210	820pF NP0 25V
2114	2020 552 94427	100pF 5% NP0 50V
2115	4822 126 14238	2,2nF X7R 50V
2116	5322 126 11583	10nF 10% X7R 50V
2117	5322 126 11583	10nF 10% X7R 50V

2118	2238 586 59812	100nF +80-20% Y5V 50V
2119	4822 124 81058	47µF 20% 4V
2120	3198 016 31080	1pF NP0 50V
2121	4822 122 33761	22pF 5% NP0 50V
2122	2222 867 15339	33pF 5% NP0 50V

2124	2238 586 59812	100nF +80-20% Y5V 50V
2126	2238 586 59812	100nF +80-20% Y5V 50V
2200	3198 017 41050	1µF Y5V 10V
2201	4822 122 33752	15pF 5% NP0 50V
2202	4822 122 33752	15pF 5% NP0 50V

2203	2238 586 59812	100nF +80-20% Y5V 50V
2204	2238 586 59812	100nF +80-20% Y5V 50V
2205	5322 126 11578	1nF 10% X7R 50V
2206	2022 009 00656	47µF 20% 6,3V
2207	2238 586 59812	100nF +80-20% Y5V 50V

2208	4822 126 13879	220nF +80-20% 16V
2209	5322 126 11583	10nF 10% X7R 50V
2210	3198 017 44740	470nF Y5V 10V
2211	2238 916 15641	22nF 10% 25V
2212	2238 586 59812	100nF +80-20% Y5V 50V

- CAPACITORS -

2213	2238 586 59812	100nF +80-20% Y5V 50V
2214	2238 586 59812	100nF +80-20% Y5V 50V
2215	3198 032 15190	100µF 20% 4V
2216	4822 126 14249	560pF 10% X7R 50V
2218	2238 586 59812	100nF +80-20% Y5V 50V

2219	2238 586 59812	100nF +80-20% Y5V 50V
2220	3198 017 41050	1µF Y5V 10V
2221	2238 586 59812	100nF +80-20% Y5V 50V
2222	2238 586 59812	100nF +80-20% Y5V 50V
2319	2022 029 00632	330µF 20% 6V3

2321	2020 021 91729	4,7µF 20% 35V
2326	4822 124 81058	47µF 20% 4V
2327	2238 586 59812	100nF +80-20% Y5V 50V
2328	5322 126 11583	10nF 10% X7R 50V
2329	4822 124 81058	47µF 20% 4V

2330	4822 124 23237	22µF 6,3V
2331	2238 586 59812	100nF +80-20% Y5V 50V
2332	4822 124 12095	100µF 20% 16V
2333	3198 017 44740	470nF Y5V 10V
2334	4822 126 14315	390pF 5% NP0 50V 0603

2335	2238 586 59812	100nF +80-20% Y5V 50V
2336	2238 586 59812	100nF +80-20% Y5V 50V
2337	3198 017 41050	1µF Y5V 10V
2338	4822 124 12084	1µF 20% SM 50V
2343	3198 017 41050	1µF Y5V 10V

2345	4822 124 81059	220µF 20% 4V
2346	2238 586 59812	100nF +80-20% Y5V 50V
2348	3198 017 41050	1µF Y5V 10V
2350	2238 586 59812	100nF +80-20% Y5V 50V
2400	3198 017 44740	470nF Y5V 10V

2400	2238 586 59812	100nF +80-20% Y5V 50V
2401	5322 126 11578	1nF 10% X7R 50V
2402	2238 586 59812	100nF +80-20% Y5V 50V
2403	5322 126 11578	1nF 10% X7R 50V
2404	2238 586 59812	100nF +80-20% Y5V 50V

2406	2238 586 59812	100nF +80-20% Y5V 50V
2407	2238 586 59812	100nF +80-20% Y5V 50V
2408	2238 586 59812	100nF +80-20% Y5V 50V
2500	4822 126 14241	330pF NP0 50V
2501	4822 124 81059	220µF 20% 4V

2502	4822 126 14491	2,2µF 10V 0805
2503	2222 867 15339	33pF 5% NP0 50V
2511	2020 021 91729	4,7µF 20% 35V
2515	4822 126 14238	2,2nF X7R 50V
2516	4822 126 14247	1,5nF X7R 50V

2520	2238 586 59812	100nF +80-20% Y5V 50V
2522	4822 126 13883	220pF 5% 50V
2523	2238 586 59812	100nF +80-20% Y5V 50V
2524	4822 126 13883	220pF 5% 50V
2525	4822 124 23002	10µF 16V

ELECTRICAL PARTSLIST - COMBI BOARD

- CAPACITORS -

2526	3198 017 41050	1µF Y5V 10V
2527	2020 021 91729	4,7µF 20% 35V
2528	4822 126 14238	2,2nF X7R 50V
2529	4822 126 14247	1,5nF X7R 50V
2530	3198 017 41050	1µF Y5V 10V

2531	4822 126 14241	330pF NP0 50V
2532	4822 124 81059	220µF 20% 4V
2533	4822 126 14491	2,2µF 10V
2534	2222 867 15339	33pF 5% NP0 50V
2535	3198 017 41050	1µF Y5V 10V

2536	4822 124 81058	47µF 20% 4V
2537	2238 586 59812	100nF +80-20% Y5V 50V
2538	3198 032 28210	220µF 20%
2539	2238 586 59812	100nF +80-20% Y5V 50V

- RESISTORS -

3104	4822 051 30103	10K 5% 0,062W
3105	4822 051 30103	10K 5% 0,062W
3106	4822 117 13608	4,7R 5% 0,0016W
3107	4822 051 30103	10K 5% 0,062W
3108	4822 051 30103	10K 5% 0,062W

3109	4822 051 30223	22K 5% 0,062W
3110	4822 051 30222	2,2K 5% 0,062W
3111	4822 051 30101	100R 5% 0,062W
3112	4822 051 30154	150K 5% 0,062W
3113	4822 051 30472	4,7K 5% 0,062W

3114	4822 051 30332	3,3K 5% 0,062W
3115	4822 051 30152	1,5K 5% 0,062W
3118	4822 051 30102	1K 5% 0,062W
3119	4822 117 13632	100K 1% 0,62W
3123	4822 117 13613	2,2R 5%

3126	4822 051 30105	1M 5% 0,062W
3200	4822 051 30474	470K 5% 0,062W
3201	4822 051 30474	470K 5% 0,062W
3202	4822 051 30474	470K 5% 0,062W
3203	4822 051 30474	470K 5% 0,062W

3204	4822 051 30102	1K 5% 0,062W
3205	4822 051 30102	1K 5% 0,062W
3206	4822 051 30102	1K 5% 0,062W
3207	4822 051 30102	1K 5% 0,062W
3208	4822 051 30102	1K 5% 0,062W

3209	4822 051 30102	1K 5% 0,062W
3210	4822 051 30681	680R 5% 0,062W
3211	4822 117 12971	15R 5% 0,62W
3212	4822 117 13613	2,2R 5%
3214	4822 051 30222	2,2K 5% 0,062W

- RESISTORS -

3215	4822 051 30151	150R 5% 0,062W
3216	4822 051 30563	56K 5% 0,062W
3217	4822 051 30683	68K 5% 0,062W
3218	4822 051 30393	39K 5% 0,062W
3219	4822 051 30109	10R 5% 0,062W

3221	4822 051 30109	10R 5% 0,062W
3303	5322 117 13028	12K 1% 0,063W
3303	4822 051 30123	12K 5% 0,062W
3304	4822 117 12925	47K 1% 0,063W
3305	4822 051 30103	10K 5% 0,062W

3305	4822 117 12706	10K 1% 0,063W
3306	4822 051 30223	22K 5% 0,062W
3307	4822 117 13632	100K 1% 0,62W
3308	5322 117 13038	27K 1% 0,063W
3308	4822 051 30273	27K 5% 0,062W

3309	4822 051 30223	22K 5% 0,062W
3309	5322 117 13022	22K 1% 0,063W
3310	4822 051 30154	150K 5% 0,062W
3311	4822 051 30103	10K 5% 0,062W
3312	2322 615 33103	10K 5% 0,125W

3313	4822 051 30474	470K 5% 0,062W
3313	4822 051 30334	330K 5% 0,062W
3330	4822 117 13632	100K 1% 0,62W
3331	4822 051 30103	10K 5% 0,062W
3332	4822 051 30333	33K 5% 0,062W

3333	4822 117 12968	820R 5% 0,62W
3334	4822 051 30332	3,3K 5% 0,062W
3335	2322 702 70278	2,7R 5%
3336	2322 702 70278	2,7R 5%
3337	4822 117 12925	47K 1% 0,063W

3338	3198 021 32250	2,2M 5%
3339	4822 051 30474	470K 5% 0,062W
3340	4822 117 12925	47K 1% 0,063W
3341	4822 051 30474	470K 5% 0,062W
3342	4822 051 30474	470K 5% 0,062W

3345	4822 051 30332	3,3K 5% 0,062W
3346	4822 051 30223	22K 5% 0,062W
3352	4822 117 13613	2,2R 5%
3353	4822 051 30101	100R 5% 0,062W
3354	4822 051 30101	100R 5% 0,062W

3355	4822 051 30332	3,3K 5% 0,062W
3356	4822 051 30471	470R 5% 0,062W
3357	4822 051 30471	470R 5% 0,062W
3359	4822 051 30103	10K 5% 0,062W
3401	4822 051 30474	470K 5% 0,062W

3402	4822 117 13632	100K 1% 0,62W
3403	3198 021 32250	2,2M 5%
3404	4822 051 30103	10K 5% 0,062W
3405	4822 051 30474	470K 5% 0,062W
3406	2322 702 70394	390K 5%

ELECTRICAL PARTSLIST - COMBI BOARD

- RESISTORS -

3407	4822 051 30105	1M 5% 0,062W
3408	4822 051 30105	1M 5% 0,062W
3409	4822 051 30105	1M 5% 0,062W
3410	3198 021 31060	10M 5%
3410	4822 051 30475	4,7M 5% 0,062W
3411	4822 051 30102	1K 5% 0,062W
3412	4822 051 30102	1K 5% 0,062W
3413	4822 117 12891	220K 1%
3414	4822 117 12891	220K 1%
3415	4822 117 13632	100K 1% 0,62W
3416	4822 117 13632	100K 1% 0,62W
3417	4822 117 12891	220K 1%
3418	4822 117 13632	100K 1% 0,62W
3420	4822 117 13632	100K 1% 0,62W
3423	4822 117 13632	100K 1% 0,62W
3424	4822 051 30008	0R JUMPER
3425	4822 051 30103	10K 5% 0,062W
3426	4822 051 30103	10K 5% 0,062W
3427	3198 021 31060	10M 5%
3427	4822 051 30475	4,7M 5% 0,062W
3430	4822 117 12925	47K 1% 0,063W
3431	4822 051 30223	22K 5% 0,062W
3432	4822 117 12925	47K 1% 0,063W
3435	4822 051 30109	10R 5% 0,062W
3438	4822 051 30472	4,7K 5% 0,062W
3442	4822 051 30222	2,2K 5% 0,062W
3443	4822 051 30222	2,2K 5% 0,062W
3444	4822 051 30105	1M 5% 0,062W
3445	4822 051 30221	220R 5% 0,062W
3445	4822 051 30471	470R 5% 0,062W
3446	4822 117 12139	22R 5% 0,062W
3448	4822 051 30008	0R JUMPER
3500	4822 051 30472	4,7K 5% 0,062W
3501	4822 051 30123	12K 5% 0,062W
3502	3198 021 32250	2,2M 5%
3503	4822 117 12971	15R 5% 0,62W
3505	4822 051 30472	4,7K 5% 0,062W
3506	4822 051 30683	68K 5% 0,062W
3507	4822 051 30331	330R 5% 0,062W
3508	4822 051 30103	10K 5% 0,062W
3510	4822 051 30681	680R 5% 0,062W
3511	4822 051 30681	680R 5% 0,062W
3513	4822 051 30474	470K 5% 0,062W
3514	4822 117 12139	22R 5% 0,062W
3515	2322 702 60184	180K 5%
3517	4822 051 30331	330R 5% 0,062W
3518	4822 051 30474	470K 5% 0,062W
3519	4822 117 13632	100K 1% 0,62W
3521	4822 117 13632	100K 1% 0,62W
3522	4822 051 30103	10K 5% 0,062W

- RESISTORS -

3524	4822 051 30102	1K 5% 0,062W
3525	4822 117 13632	100K 1% 0,62W
3526	4822 051 30183	18K 5% 0,062W
3530	4822 051 30102	1K 5% 0,062W
3534	4822 117 13632	100K 1% 0,62W
3535	4822 051 30682	6,8K 5% 0,062W
3539	4822 117 12139	22R 5% 0,062W
3542	4822 117 13632	100K 1% 0,62W
3543	4822 051 30681	680R 5% 0,062W
3544	4822 051 30681	680R 5% 0,062W
3545	4822 051 30331	330R 5% 0,062W
3546	4822 051 30472	4,7K 5% 0,062W
3547	4822 051 30472	4,7K 5% 0,062W
3548	3198 021 32250	2,2M 5%
3549	4822 117 12971	15R 5% 0,62W
3551	4822 051 30123	12K 5% 0,062W
3552	4822 051 30683	68K 5% 0,062W
3553	4822 051 30331	330R 5% 0,062W
3554	4822 051 30103	10K 5% 0,062W
3555	2322 702 60184	180K 5%
3556	4822 117 13632	100K 1% 0,62W
3557	4822 117 13632	100K 1% 0,62W
3558	4822 117 13632	100K 1% 0,62W
3559	4822 051 30109	10R 5% 0,062W
3560	4822 117 13608	4,7R 5% 0,0016W
4001	4822 051 30008	0R JUMPER
4002	4822 051 30008	0R JUMPER

- COILS & FILTERS -

1200	4822 242 81865	CST16,93MXW0C3-TF01
5300	4822 158 10525	LAL 04T 331K
5301	4822 157 50964	100MUH
5303	4822 158 10525	LAL 04T 331K

- DIODES -

6302	9322 128 70685	DIO REC SM SS14
6304	4822 130 11416	PDZ6,8B
6401	4822 130 11397	BAS316
6500	5322 130 34331	BAV70
6501	4822 130 11397	BAS316
6502	4822 130 11551	UDZS10B
6503	5322 130 34331	BAV70

ELECTRICAL PARTSLIST - COMBI BOARD

- IC & TRANSISTORS -

7100	5322 130 60123	BC807-40
7101	9322 182 66671	IC SM AN8399SA
7103	5322 130 60159	BC846B
7104	5322 130 60159	BC846B
7105	5322 130 60159	BC846B
7200	9322 175 89668	MSM51V17405F-60SJ
7201	9322 182 62671	IC SM MN662786SB
7202	9322 175 89668	MSM51V17405F-60SJ
7300	9322 186 76671	IC SM AN41502
7301	5322 130 61569	BC868
7303	4822 130 42615	BC817-40
7304	4822 130 60142	BC869
7306	4822 130 60373	BC856B
7307	5322 130 60159	BC846B
7309	5322 130 60123	BC807-40
7310	5322 130 60159	BC846B
7311	4822 130 60142	BC869
7312	5322 130 60159	BC846B
7313	5322 130 60159	BC846B
7401	9340 217 80115	BC847CW
7402	5322 130 60159	BC846B
7403	4822 130 60373	BC856B
7404	5322 130 60159	BC846B
7405	3140 110 51961	MCU MN101C39C
7406	4822 130 60373	BC856B
7407	4822 130 60373	BC856B
7408	5322 130 60123	BC807-40
7500	4822 209 33165	TDA1308T/N1
7501	4822 130 42615	BC817-40
7503	4822 130 60373	BC856B
7506	5322 130 60123	BC807-40
7508	4822 130 42615	BC817-40
7510	5322 130 60159	BC846B
7511	5322 130 60159	BC846B
7512	4822 130 42615	BC817-40
7513	4822 130 42615	BC817-40
7515	5322 130 60159	BC846B

Note: Only these parts mentioned in the list are normal service parts.