

# Service Service Service

For repair of the CD mechanism see Service Manual RCD1F

Voor reparatie C.D. mechanisme zie Service Manual RCD1F

Consulter la Documentation Service RCD 1F en matière de mécanisme du CD

Reparatur des CD-Mechanismus siehe Service Manual RCD1F

Per quanto è del meccanismo del CD, riferirsi alla Documentazione di Servizio RCD 1F

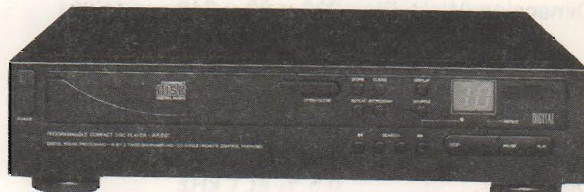

44 622 A

# Service Manual



<b>(GB) CONTENTS</b>	page
Specifications	2
Controls	3
Circuit diagram of the power supply	4
Printed Wiring Board of the power supply	4
Circuit diagram of the control section	5-6
Printed Wiring Board of the control section	7-8
Circuit diagram of the decoder	9-10
Printed Wiring Board of the decoder/servo	11-12
Circuit diagram of the servo	13-14
Printed Wiring Board of the decoder/servo	15-16
Wiring diagram	17-18
Adjustments	19+22
Exploded view	23-24
Mechanical parts list	25
Electrical parts list	26

<b>(NL) INHOUD</b>	pagina
Specificaties	2
Bedieningsorganen	3
Principeschema voeding	4
Printpaneel voeding	4
Principeschema bediening	5-6
Printpaneel bediening	7-8
Principeschema decoder	9-10
Printpaneel decoder/servo	11-12
Principeschema servo	13-14
Printpaneel decoder/servo	15-16
Bedradingstekening	17-18
Afregelingen	19+22
Explodedview	23-24
Mechanische stuklijst	25
Electronische stuklijst	26

<b>(F) TABLE DES MATIERES</b>	page
Caractéristiques techniques	2
Organes de commande	3
Schéma de principe alimentation	4
Platine alimentation	4
Schéma de principe commande	5-6
Platine commande	7-8
Schéma de principe décodeur	9-10
Platine décodeur/asservis.	11-12
Schéma de principe asservissement	13-14
Platine décodeur/asservissement	15-16
Plan de câblage	17-18
Ajustages	19+22
Vue éclatée	23-24
Liste des pièces mécaniques	25
Liste des pièces électriques	26

<b>(D) INHALTSANGABE</b>	Seite
Spezifikationen	2
Bedienungsorgane	3
Pinzipschaltbild Stromversorgung	4
Printplatte Stromversorgung	4
Pinzipschaltbild Bedienung	5-6
Printplatte Bedienung	7-8
Pinzipschaltbild Decoder	9-10
Printplatte Decoder/Servo	11-12
Pinzipschaltbild Servo	13-14
Printplatte Decoder/Servo	15-16
Verdrahtungszeichnung	17-18
Einstellungen	19+22
Explosionszeichnung	23-24
Mechanische Stückliste	25
Elektrische Stückliste	26

<b>(I) CONTENUTO</b>	page
Dati tecnici	2
Organi di comando	3
Schema di principio alimentazione	4
Stampato alimentazione	4
Schema di principio comando	5-6
Stampato comando	7-8
Schema di principio decodatore	9-10
Stampato decodatore/servo	11-12
Schema di principio servo	13-14
Stampato decodatore/servo	15-16
Schema di cablaggio	17-18
Regolazioni	19+22
Vista esplosa	23-24
Elenco dei pezzi meccanici	25
Elenco dei pezzi elettrici	26

**CLASS 1  
LASER PRODUCT**

3122 140 03420

## Specifications

### General

Power supply	: 220 V
Service solution for	: 120 V - 240 V
Mains frequencies	: 50 Hz-60 Hz
Power consumption	: 60 W
Dimension (WxHxD)	: 336 x 82 x 340 cm AK691 420 x 82 x 340 cm AK696

### Audio performance

Frequency response	: 20-20.000 Hz +2/-4dB
Signal to noise ratio	: 80dB (A weighted)
Distortion	: 0,5 % at 1 kHz
Channel crosstalk	: -50 dB at 1 kHz
Output voltage	: 1,5 V $\pm$ 2 dB
Load impedance	: 47 k $\Omega$

#### GB WARNING

All ICs and many other semi-conductors are susceptible to electrostatic discharges (ESD). Careless handling during repair can reduce life drastically.

When repairing, make sure that you are connected with the same potential as the mass of the set via a wrist wrap with resistance. Keep components and tools also at this potential.

#### F ATTENTION

Tous les IC et beaucoup d'autres semi-conducteurs sont sensibles aux décharges statiques (ESD).

Leur longévité pourrait être considérablement écourtée par le fait qu'aucune précaution n'est prise à leur manipulation.

Lors de réparations, s'assurer de bien être relié au même potentiel que la masse de l'appareil et enfiler le bracelet serti d'une résistance de sécurité.

Veiller à ce que les composants ainsi que les outils que l'on utilise soient également à ce potentiel.

#### GB

Safety regulations require that the set be restored to its original condition and that parts which are identical with those specified be used.

#### NL

Veiligheidsbepalingen vereisen, dat het apparaat in zijn oorspronkelijke toestand wordt teruggebracht en dat onderdelen, identiek aan de gespecificeerde, worden toegepast.

#### F

Les normes de sécurité exigent que l'appareil soit remis à l'état d'origine et que soient utilisées les pièces de rechange identiques à celles spécifiées.

#### ESD



#### D WARNUNG

Alle ICs und viele andere Halbleiter sind empfindlich gegenüber elektrostatischen Entladungen (ESD).

Unvorsichtige Behandlung im Reparaturfall kann die Lebensdauer drastisch reduzieren.

Veranlassen Sie, dass Sie im Reparaturfall über ein Pulsarmband mit Widerstand verbunden sind mit dem gleichen Potential wie die Masse des Gerätes.

Bauteile und Hilfsmittel auch auf dieses gleiche Potential halten.

#### D

Bei jeder Reparatur sind die geltenden Sicherheitsvorschriften zu beachten. Der Originalzustand des Geräts darf nicht verändert werden; für Reparaturen sind Original-Ersatzteile zu verwenden.

#### I

Le norme di sicurezza esigono che l'apparecchio venga rimesso nelle condizioni originali e che siano utilizzati i pezzi di ricambio identici a quelli specificati.

#### NL WAARSCHUWING

Alle IC's en vele andere halfgeleiders zijn gevoelig voor electrostatische ontladingen (ESD).

Onzorgvuldig behandelen tijdens reparatie kan de levensduur drastisch doen verminderen. Zorg ervoor dat u tijdens reparatie via een polsband met weerstand verbonden bent met hetzelfde potentiaal als de massa van het apparaat.

Houd componenten en hulpmiddelen ook op ditzelfde potentiaal.

#### I AVVERTIMENTO

Tutti IC e parecchi semi-conduttori sono sensibili alle scariche statiche (ESD).

La loro longevità potrebbe essere fortemente ridatta in caso di non osservazione della più grande cauzione alla loro manipolazione.

Durante le riparazioni occorre quindi essere collegato allo stesso potenziale che quello della massa dell'apparecchio tramite un braccialetto a resistenza.

Assicurarsi che i componenti e anche gli utensili con quali si lavora siano anche a questo potenziale.

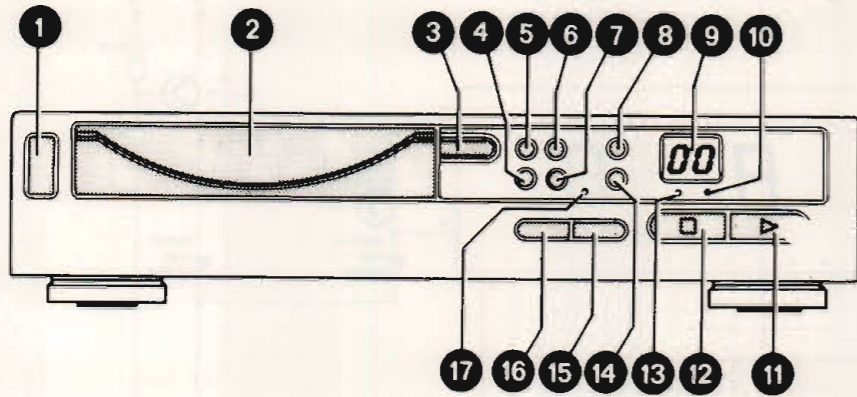

Fig. 1

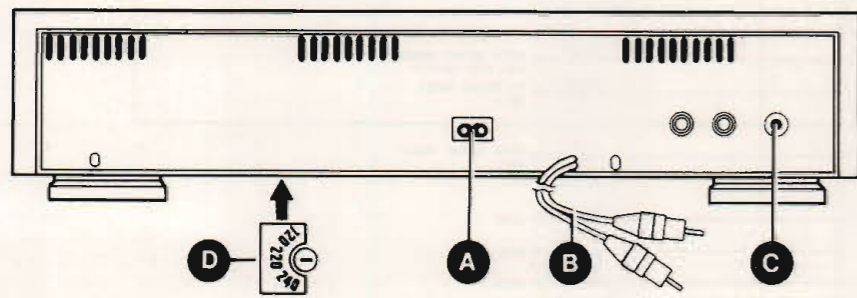
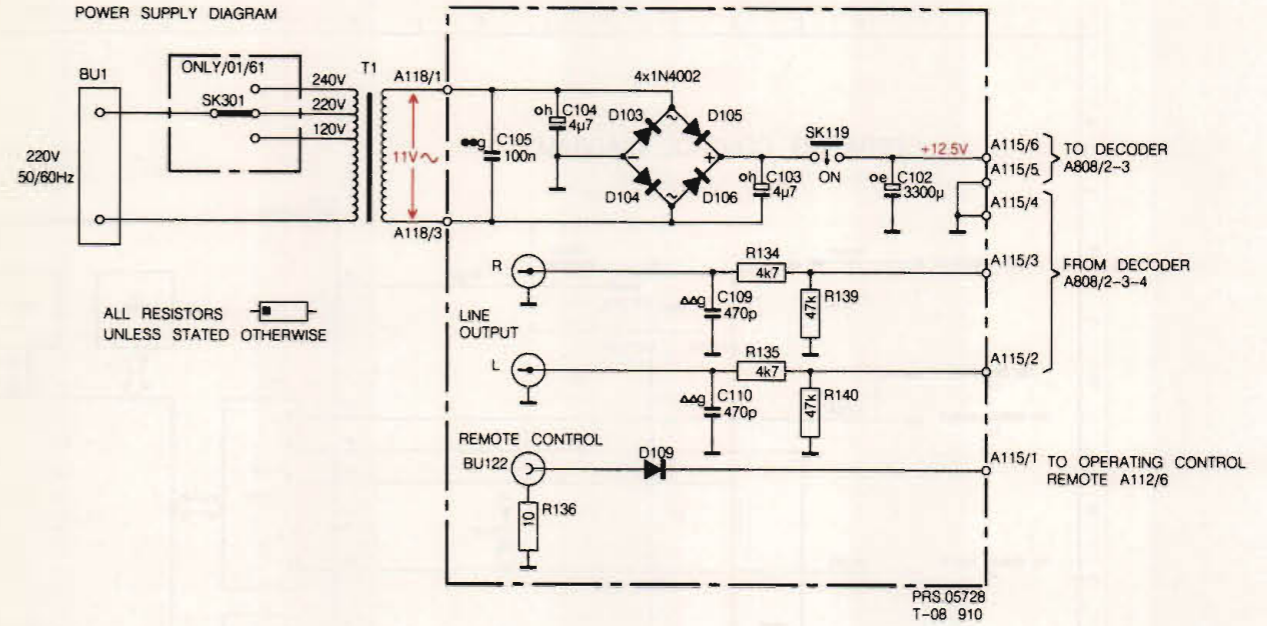

Fig. 2

44 553 A11

- |                          |                                   |
|--------------------------|-----------------------------------|
| 1 Power switch SK119     | 12 Shuffle indicator D101         |
| 2 C.D. tray SK104        | 13 Next/search key SK111          |
| 3 Open/close key SK106   | 14 Previous/search key SK107      |
| 4 Store key SK109        | 15 Introsan key SK108             |
| 5 Clear key SK105        | 16 Repeat key SK110               |
| 6 Display key SK110      | 17 Scan indicator D107            |
| 7 Shuffle key Q110       |                                   |
| 8 Track display SK101    | A mains socket BU1                |
| 9 Play/pause key SK102   | B Audio output ST110              |
| 10 Stop key SK102        | C Remote control BU122            |
| 11 Repeat indicator D102 | D Voltage selector SK301 only /01 |



A115	B 2	C102	A 1	C109	A 3	D105	B 3	R135	A 2
A118	B 3	C103	B 2	C110	A 2	D106	B 3	R136	A 2
A119	A 1	C104	B 3	D103	A 3	D109	A 2	R139	A 2
A122	A 2	C105	B 3	D104	B 3	R134	A 3	R140	A 2

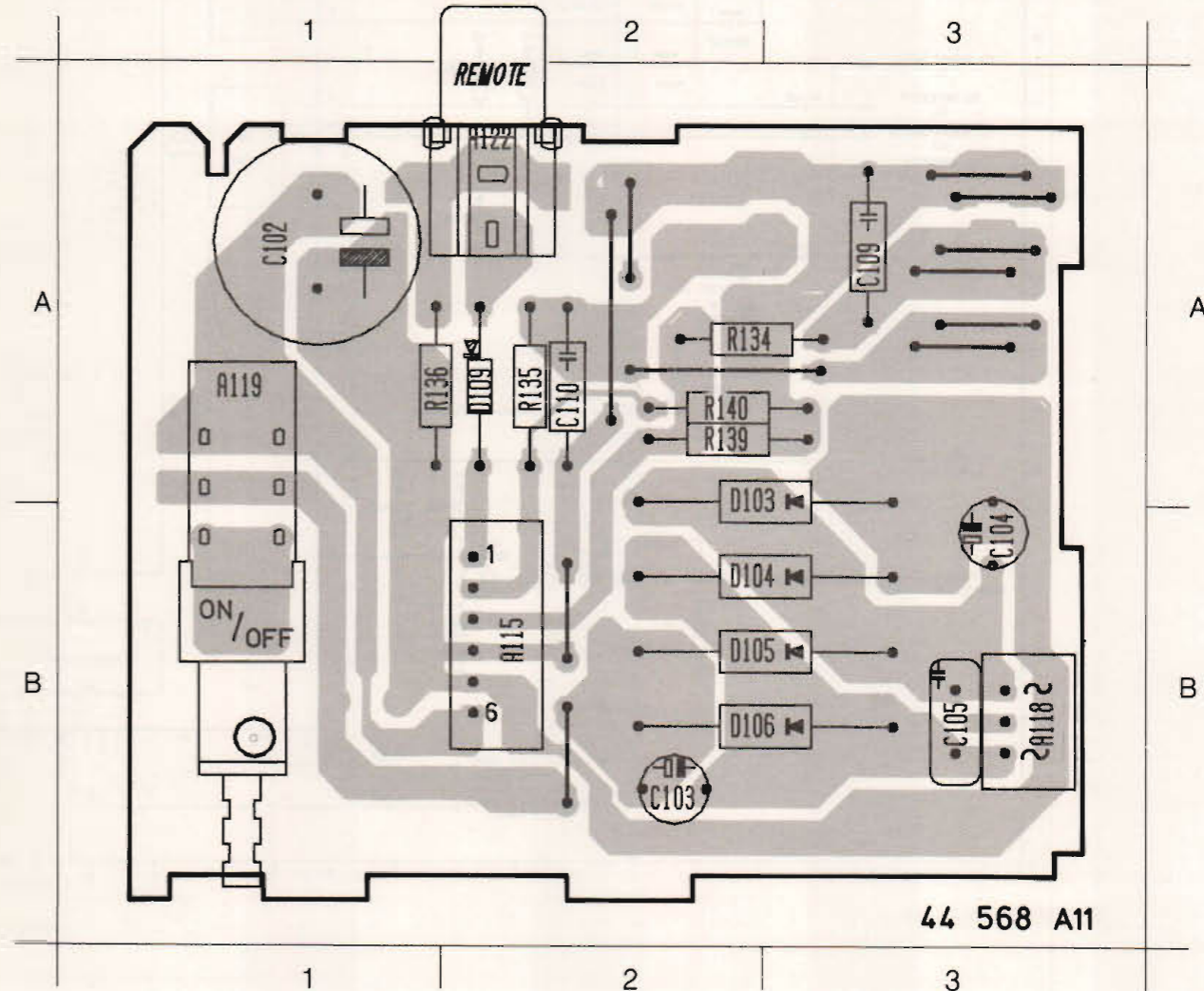

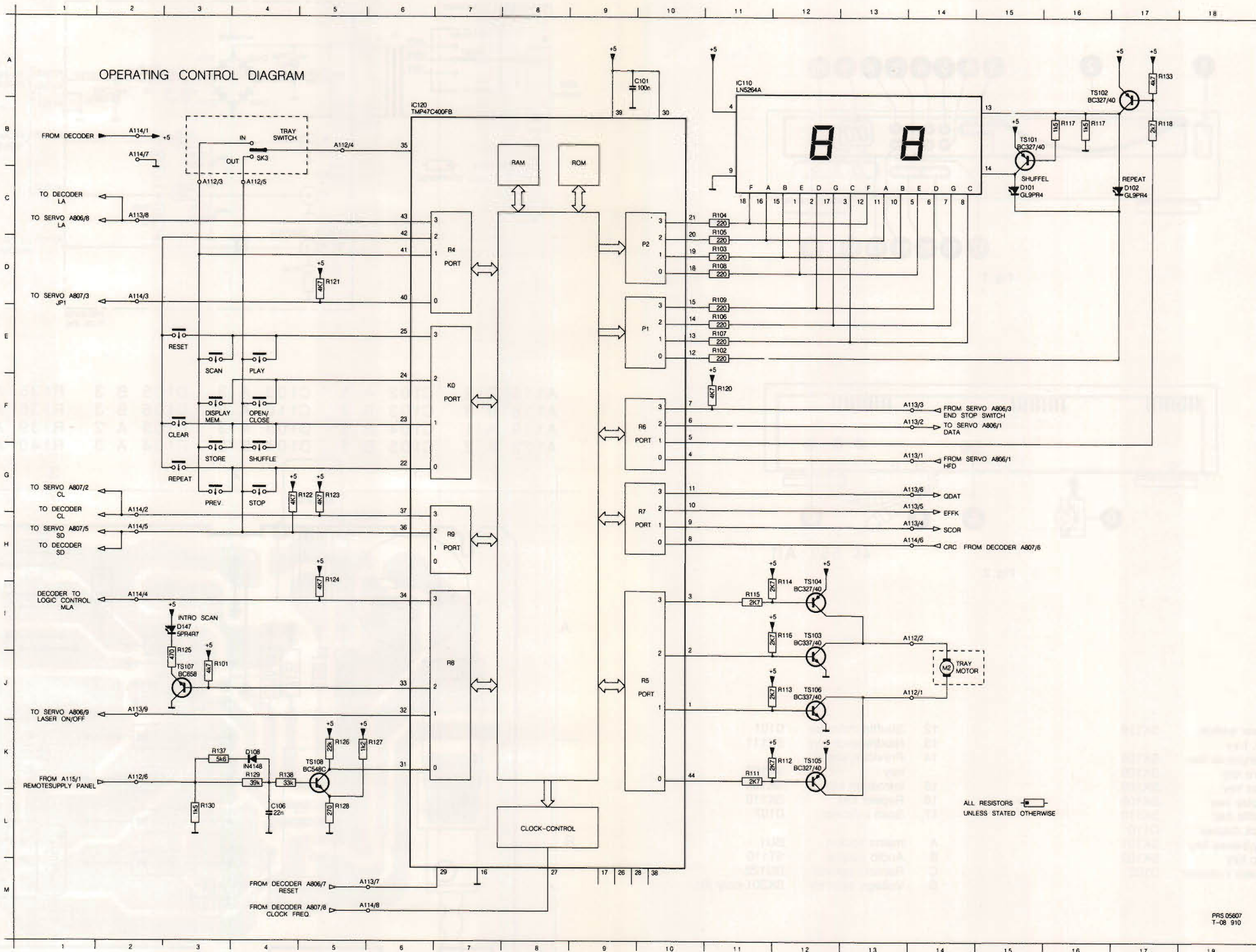

- C101 A10
- C106 L 4
- D101 C15
- D102 C17
- D108 K 4
- D147 I 3
- I C120 B 6
- M2 J 14
- R101 J 3
- R102 E11
- R103 D11
- R104 C11
- R105 C11
- R106 E11
- R107 E11
- R108 D11
- R109 D11
- R110 C11
- R111 K11
- R112 K12
- R113 J12
- R114 H12
- R115 I11
- R116 I12
- R117 B16
- R118 B16
- R119 B17
- R120 F11
- R121 D 5
- R122 G 5
- R123 G 5
- R124 H 5
- R125 I 3
- R126 K 5
- R127 K 5
- R128 L 5
- R129 K 4
- R130 L 3
- R133 A17
- R137 K 3
- R138 K 4
- SK3 B 4
- TS101 B15
- TS102 A16
- TS103 I12
- TS104 H12
- TS105 K12
- TS106 J12
- TS107 J 3
- TS108 K 5

- A113/3 FROM SERVO A806/3
- A113/2 TO SERVO A806/1
- A113/1 FROM SERVO A806/1
- A113/6 QDAT
- A113/5 EFFK
- A113/4 SCOR
- A114/6 CRC FROM DECODER A807/6
- A112/2
- A112/1
- A113/7 FROM DECODER A806/7
- A114/8 FROM DECODER A807/8

ALL RESISTORS UNLESS STATED OTHERWISE

A101	B 7	A108	A 2	C101	A 7	Q102	A 7	Q110	A 5	R106	A 5	R113	B 3	R120	B 5	R127	B 1
A102	B 4	A109	A 2	C106	B 1	Q103	B 3	Q120	B 6	R107	A 5	R114	B 3	R121	B 7	R128	B 1
A103	A 3	A110	A 2	D101	A 4	Q104	B 2	R101	A 7	R108	A 5	R115	B 3	R122	A 7	R129	B 2
A104	A 1	A111	B 3	D102	A 5	Q105	B 2	R102	B 5	R109	A 5	R116	B 3	R123	B 7	R130	B 1
A105	A 3	A112	B 1	D107	A 3	Q106	B 2	R103	A 6	R110	A 7	R117	A 6	R124	A 7	R133	A 7
A106	A 2	A113	B 5	D108	B 1	Q107	A 3	R104	A 6	R111	B 3	R118	B 6	R125	A 3	R137	B 2
A107	B 2	A114	B 7	Q101	A 7	Q108	B 1	R105	A 6	R112	B 3	R119	A 6	R126	A 4	R138	B 1

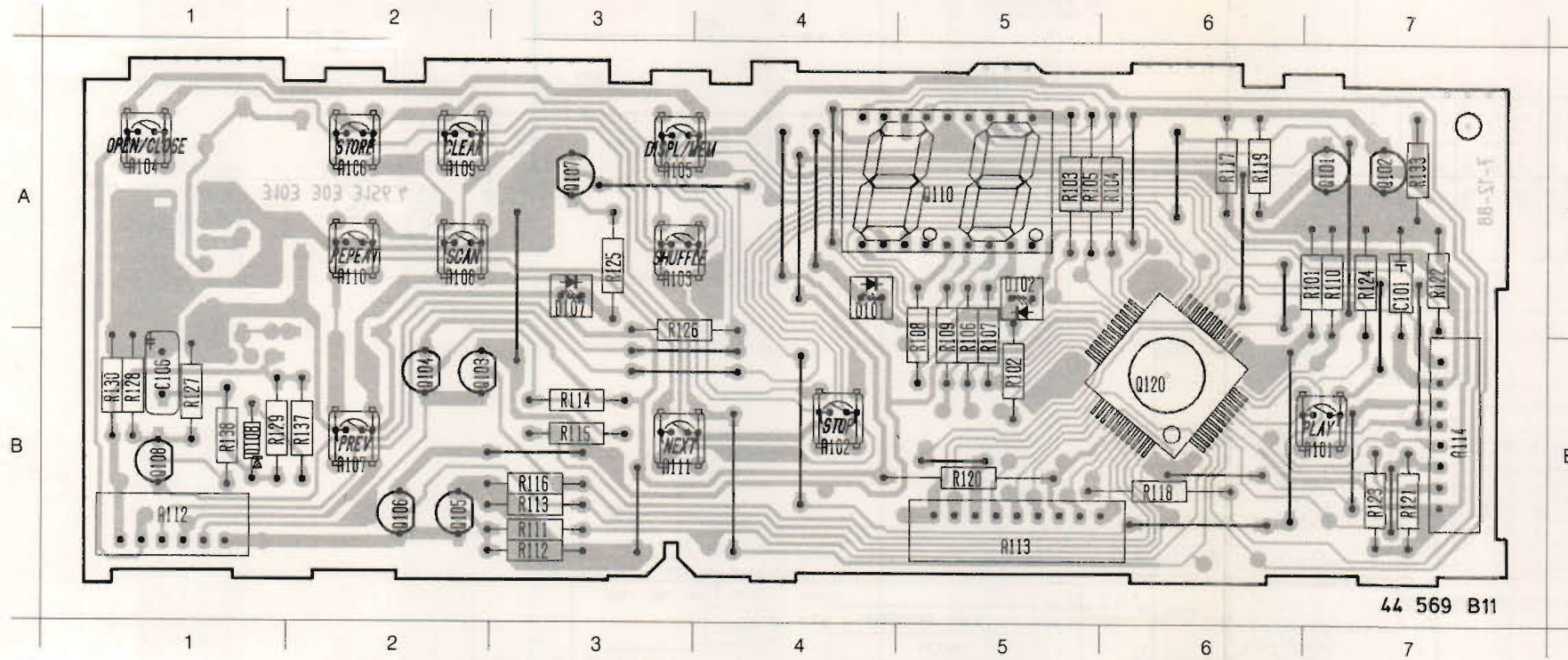

PRS.04250

A101	B 1	C101	A 1	Q102	A 1	Q110	A 3	R104	A 7	R108	A 6	R113	B 5	R120	B 3	R126	B 7
A102	B 4	C106	B 7	Q103	B 6	Q120	B 2	R105	A 3	R109	A 3	R114	B 5	R121	B 1	R127	B 7
A107	B 6	D101	A 4	Q104	B 6	R101	A 2	R105	A 5	R109	A 6	R115	B 5	R122	A 1	R128	B 7
A111	B 5	D102	A 3	Q105	B 6	R102	B 3	R106	A 3	R110	A 2	R116	B 5	R123	B 1	R130	B 7
A112	B 7	D107	A 5	Q106	B 6	R103	A 3	R106	A 6	R110	A 6	R117	A 2	R124	A 1	R133	A 1
A113	B 3	D108	B 7	Q107	A 5	R103	A 5	R107	A 3	R111	B 5	R118	B 2	R125	A 5	R137	B 7
A114	B 1	Q101	A 2	Q108	B 7	R104	A 3	R108	A 4	R112	B 5	R119	A 2	R126	A 5	R138	B 7

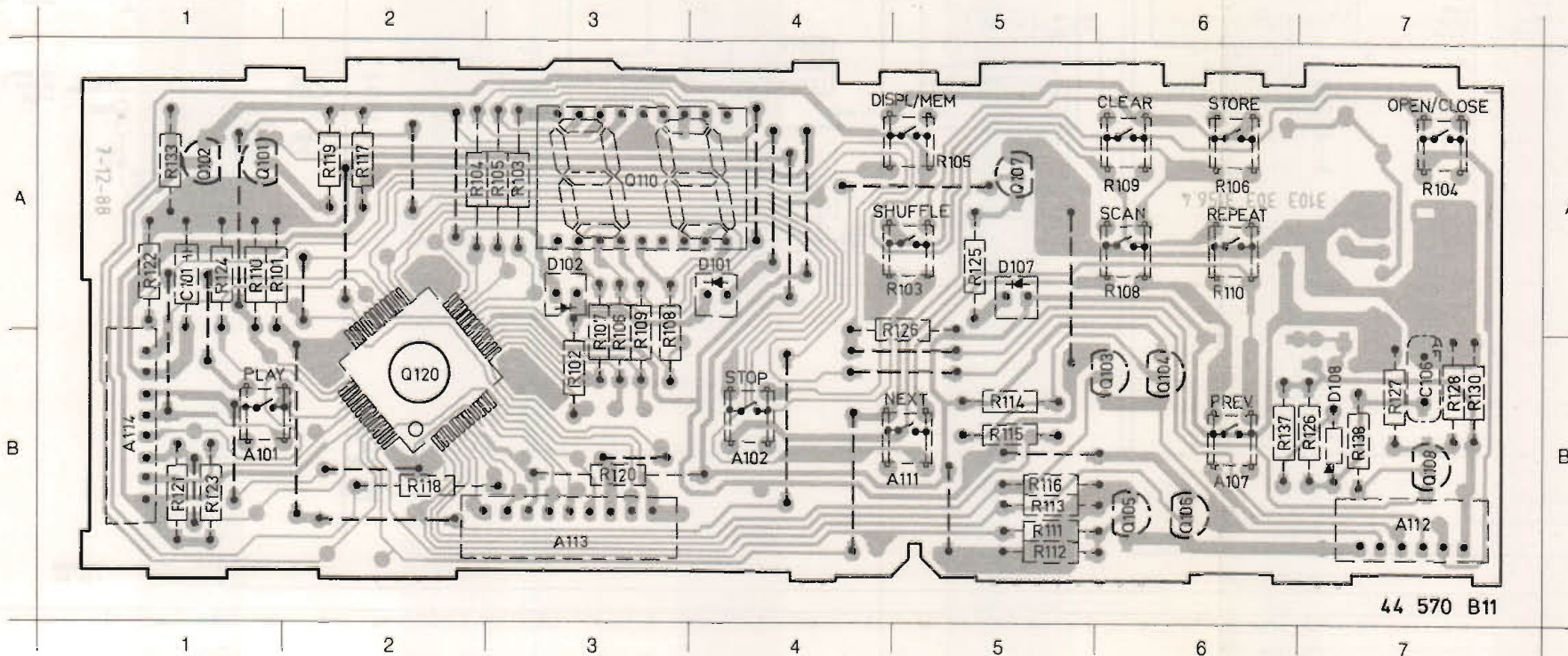

PRS.04248

CB28 B16 CB43 G21 CB53 B16 CB62 B 4 CB66 F17 CB71 B18 CB76 A16 CB93 J21 D952 K 4 IC841 K18 IC863 F17 IC871 B17 R841 G20 R844 H21 R847 N19 R853 L 3 R859 C18 R862 B 4 R865 E17 R867 K15 R891 J20 R894 K21 R902 A16 TS844 M19 TS853 L 2 TS859 C19  
 CB41 G18 CB44 H21 CB60 H12 CB63 B 3 CB67 L13 CB72 B17 CB81 J18 CB94 K22 D853 C18 IC861 B12 IC864 K15 CB81 J10 R842 H20 R845 M19 R851 K 3 R854 L 4 R860 C19 R863 B 2 R866 K16 R869 B 3 R892 J20 R896 K19 TS842 G20 TS851 K 2 TS854 L 4 TS891 J20  
 CB42 G19 CB52 C20 CB61 B16 CB64 B 2 CB68 K14 CB73 B16 CB82 J19 D851 K 3 IC841 H18 IC862 A10 IC864 K13 R808 A16 R843 G22 R846 H19 R852 K 3 R858 B18 R861 L14 H864 B 5 R867 K16 R889 G19 R893 J22 R900 J19 TS843 H21 TS852 K 4 TS858 C19 TS892 K21

DECODER DIAGRAM

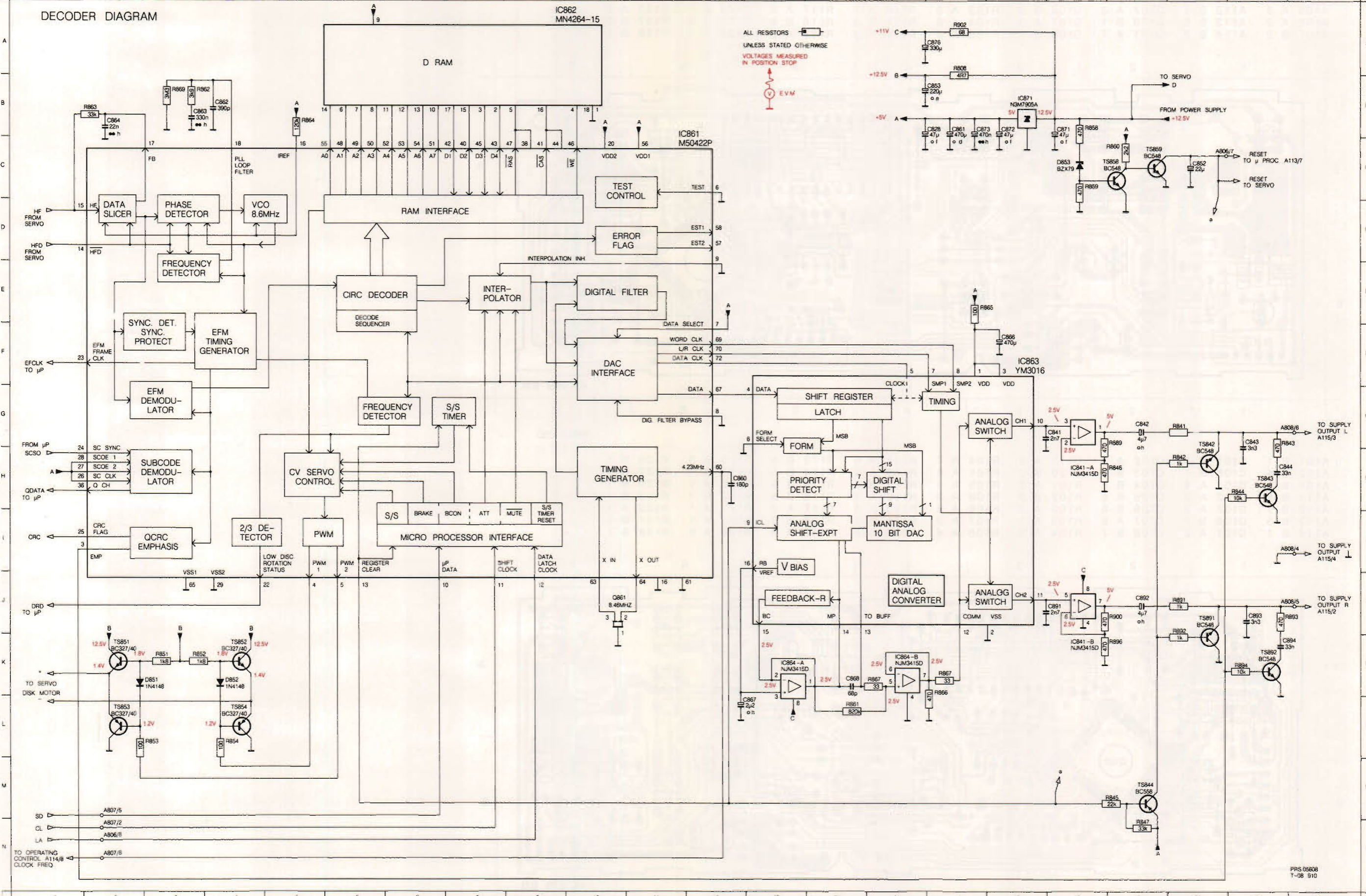

PRS 05608  
T-08 910

R801	F 3	C805	Q 4	C816	E 6	C827	D 3	C841	F12	C863	F 7	C891	F12	Q811	F 5	Q852	D 7	Q891	E13	R809	D 8	R820	D 6	R831	E 6	R841	E12	R851	D 7	R861	Q13	R875	C 4	R887	C 3	R901	Q11
R802	C 3	C806	Q 5	C817	D 5	C828	F 6	C842	F11	C864	F 7	C892	F13	Q812	D 8	Q853	C 7	Q892	E12	R811	D 8	R821	D 7	R832	D 5	R842	F12	R852	D 6	R862	F 7	R876	D 4	R890	Q 6	R902	D11
R803	C 8	C807	Q 5	C818	D 6	C829	F 4	C843	E13	C865	F 8	C893	E13	Q813	C 5	Q854	C 7	R801	F 3	R812	D 8	R822	E 6	R833	D 4	R843	D13	R853	D 8	R863	F 8	R877	D 8	R891	E12		
R806	D 9	C808	Q 3	C819	D 5	C830	C 5	C844	D12	C866	G12	C894	E12	Q814	C 4	Q858	D11	R802	F 4	R813	F 6	R824	E 6	R834	E 5	R844	E13	R854	D 6	R864	F 8	R878	D 6	R892	E12		
R807	F10	C810	F 6	C820	D 5	C832	D 3	C851	D 7	C867	G12	D851	D 7	Q815	D 6	Q859	C10	R803	G 4	R814	F 6	R825	E 6	R835	D 4	R845	D10	R855	E 4	R866	F13	R879	E 9	R893	D13		
R808	B13	C811	Q 7	C821	E 5	C834	C 6	C852	E 9	C868	G13	D852	D 7	Q841	F12	Q861	G 9	R804	G 5	R815	G 7	R826	E 5	R836	D 4	R846	F11	R856	C 4	R867	F13	R880	G 6	R894	E13		
C801	Q 3	C812	Q 6	C822	D 4	C835	C 6	C853	C 5	C871	C13	D853	E12	Q842	E12	Q862	F10	R805	G 4	R816	G 7	R827	E 5	R837	E 4	R847	E11	R857	C 5	R871	E 3	R881	G 7	R895	F 7		
C802	F 3	C813	Q 6	C824	D 4	C836	E 6	C860	F 9	C872	D11	L861	Q10	Q843	E12	Q863	G12	R806	G 5	R817	F 6	R828	E 5	R838	E 4	R848	E 6	R858	D11	R872	D 3	R884	F13	R896	F13		
C803	F 4	C814	F 6	C825	E 3	C837	D 4	C861	E10	C873	F10	Q801	G 4	Q844	E11	Q864	G12	R807	F 4	R818	E 6	R829	E 5	R839	E 4	R849	D 4	R859	E11	R873	D 5	R885	C 3	R899	F11		
C804	F 4	C815	F 6	C826	E 3	C838	F 6	C862	E 7	C876	F12	Q810	H 8	Q851	D 7	Q871	C12	R808	D 8	R819	D 6	R830	G 7	R840	F 4	R850	D 4	R860	D11	R874	C 5	R886	C 3	R900	F12		

SERVO / DECODER PANEL

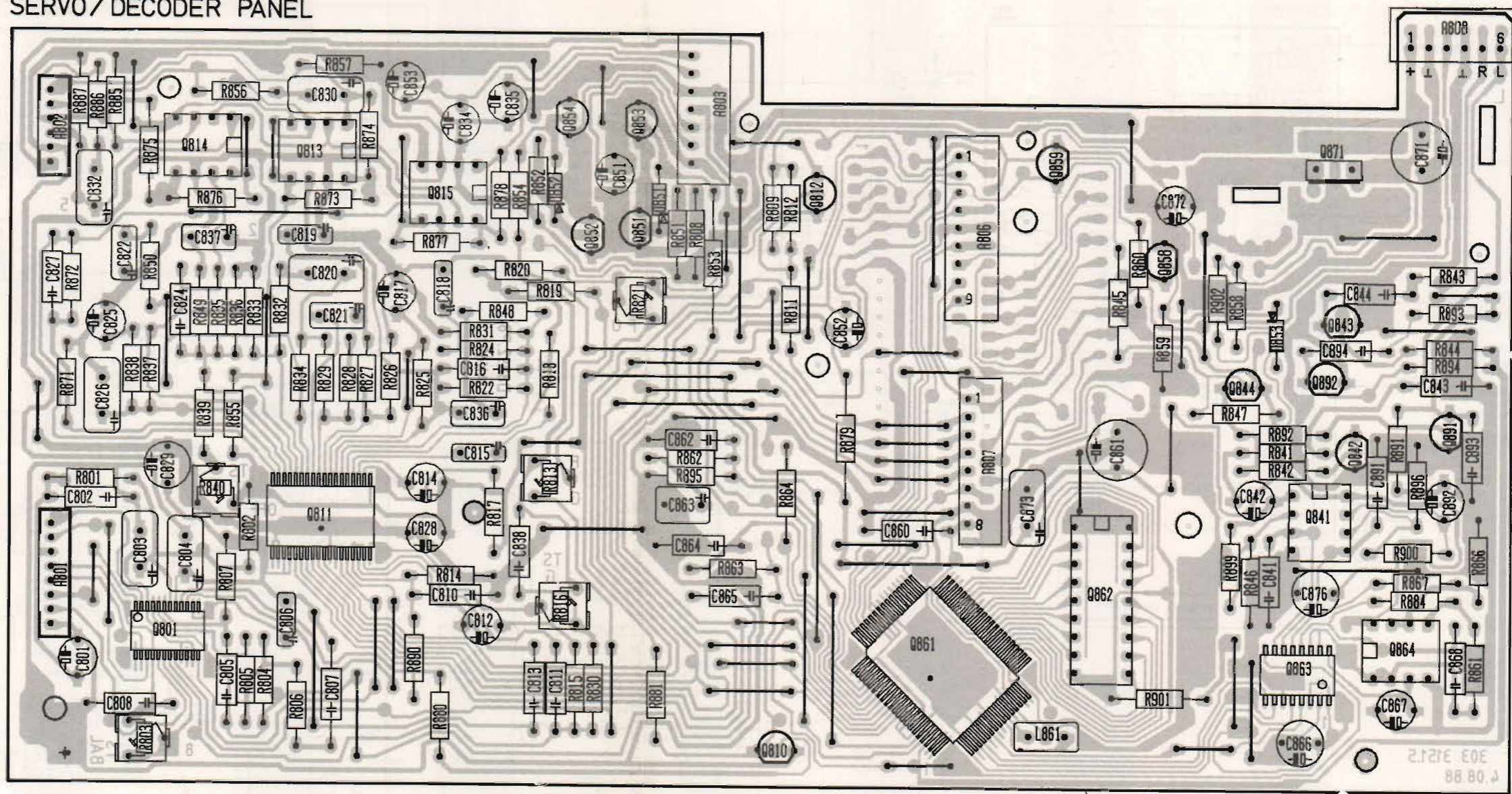

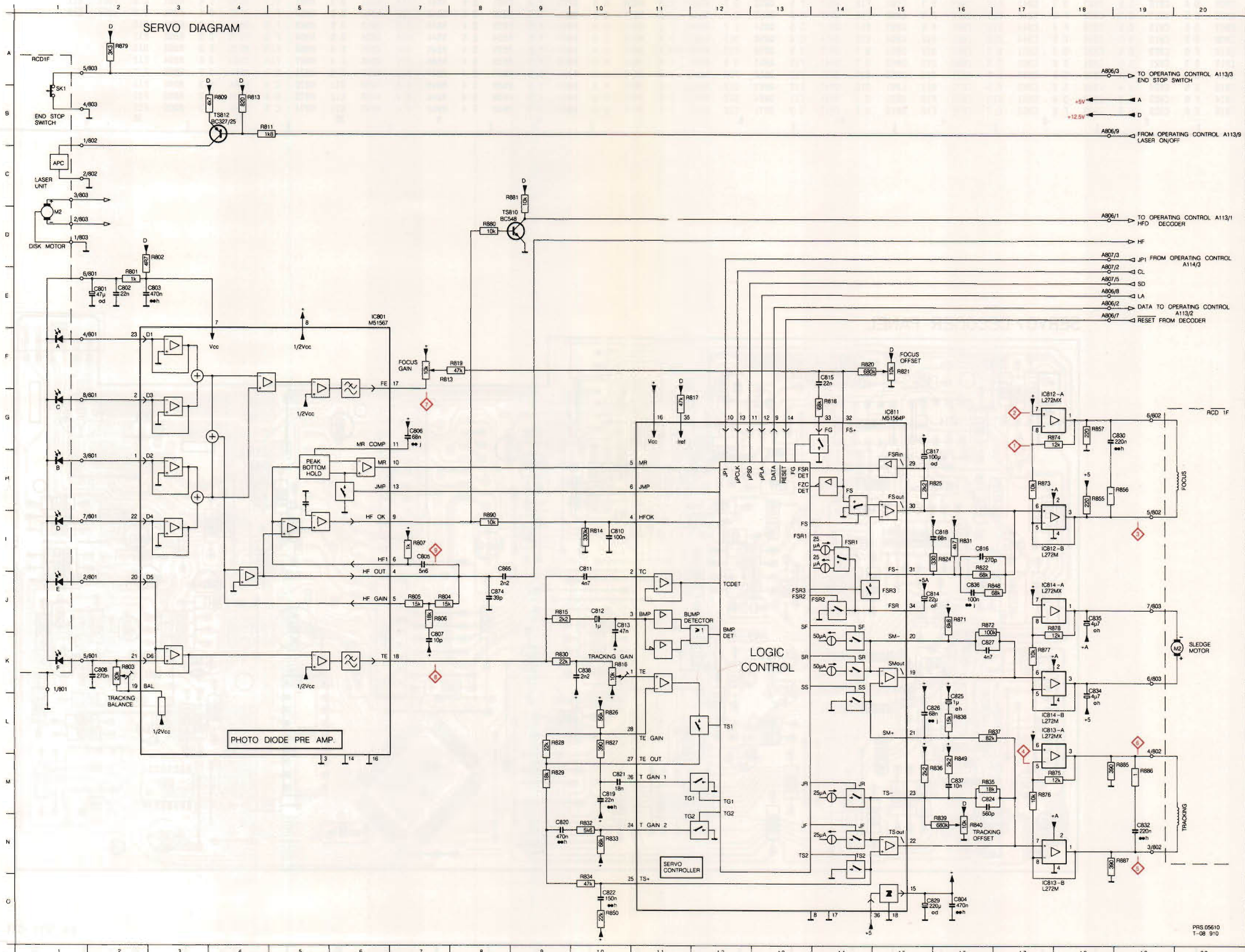

C801	E 2
C802	E 2
C803	E 3
C804	O16
C805	I 7
C806	G 7
C807	K 7
C808	K 2
C810	I10
C811	I10
C812	J10
C813	J10
C814	J16
C815	F14
C816	I16
C817	G16
C818	I16
C819	M10
C820	N 9
C821	M10
C822	O10
C824	M16
C825	L16
C826	L16
C827	K16
C829	O16
C830	G19
C832	N19
C834	K18
C835	J16
C836	J16
C837	M16
C838	K10
C855	I 8
C874	J 8
C875	E 16
C811	G15
C812	G17
C812	I17
C813	L17
C813	O17
C814	J17
C814	L17
M2	K20
M2	D 1
R801	E 2
R802	E 3
R803	K 2
R804	J 7
R805	J 7
R806	J 7
R807	I 7
R808	B 4
R811	B 4
R813	F 7
R813	B 4
R814	I10
R815	J 9
R816	K10
R817	G12
R818	G14
R819	F 8
R820	F14
R821	F15
R822	L 9
R824	I16
R825	H16
R826	L10
R827	L10
R828	M 9
R829	M 9
R830	K 9
R831	I16
R832	N10
R833	N10
R834	O10
R835	M16
R836	M16
R837	L17
R838	L16
R839	N16
R840	N16
R848	J17
R849	M16
R850	O10
R855	H18
R856	H18
R857	G18
R871	J16
R872	J16
R873	H17
R874	G18
R875	M16
R876	M17
R877	K17
R878	J18
R879	A 2
R880	D 8
R881	C 9
R885	M19
R886	M19
R887	N19
R890	I 8
SK1	B 1
TS810	B 9
TS812	B 4



R801	F 3	C805	G 4	C816	E 6	C827	D 3	C841	F12	C863	F 7	C891	F12	Q811	F 5	Q852	D 7	Q891	E13	R809	D 8	R820	D 6	R831	E 6	R841	E12	R851	D 7	R861	G13	R875	C 4	R887	C 3	R901	Q11
R802	C 3	C806	G 5	C817	D 5	C828	F 6	C842	F11	C864	F 7	C892	F13	Q812	D 8	Q853	C 7	Q892	E12	R811	D 8	R821	D 7	R832	D 5	R842	F12	R852	D 6	R862	F 7	R876	D 4	R890	G 6	R902	D11
R803	C 8	C807	G 5	C818	D 6	C829	F 4	C843	E13	C865	F 8	C893	E13	Q813	C 5	Q854	C 7	R801	F 3	R812	D 8	R822	E 6	R833	D 4	R843	D13	R853	D 8	R863	F 8	R877	D 8	R891	E12		
R806	D 9	C808	G 3	C819	D 5	C830	C 5	C844	D12	C866	Q12	C894	E12	Q814	C 4	Q858	D11	R802	F 4	R813	F 6	R824	E 6	R834	E 5	R844	E13	R854	D 6	R864	F 8	R878	D 6	R892	E12		
R807	F10	C810	F 6	C820	D 5	C832	D 3	C851	D 7	C867	Q12	C851	D 7	Q815	D 6	Q859	C10	R803	G 4	R814	F 6	R825	E 6	R835	D 4	R845	D10	R855	E 4	R866	F13	R879	E 9	R893	D13		
R808	B13	C811	G 7	C821	E 5	C834	C 6	C852	E 9	C868	G13	C852	D 7	Q816	D 6	Q861	G 9	R804	G 5	R815	G 7	R826	E 5	R836	D 4	R846	F11	R856	C 4	R867	F13	R880	G 6	R894	E13		
C801	G 3	C812	G 6	C822	D 4	C835	C 6	C853	C 5	C871	C13	C853	E12	Q817	E12	Q862	F10	R805	G 4	R816	G 7	R827	E 5	R837	E 4	R847	E11	R857	C 5	R871	E 3	R881	G 7	R895	F 7		
C802	F 3	C813	G 6	C824	D 4	C836	E 6	C860	F 9	C872	D11	L861	G10	Q818	E12	Q863	G12	R806	G 5	R817	F 6	R828	E 5	R838	E 4	R848	E 6	R858	D11	R872	D 3	R884	F13	R896	F13		
C803	F 4	C814	F 6	C825	E 3	C837	D 4	C861	E10	C873	F10	Q801	G 4	Q819	E11	Q864	G12	R807	F 4	R818	E 6	R829	E 5	R839	E 4	R849	D 4	R859	E11	R873	D 5	R885	C 3	R899	F11		
C804	F 4	C815	F 6	C826	E 3	C838	F 6	C862	E 7	C876	F12	Q810	H 8	Q820	D 7	Q871	C12	R808	D 8	R819	D 6	R830	G 7	R840	F 4	R850	D 4	R860	D11	R874	C 5	R886	C 3	R900	F12		

### SERVO/DECODER PANEL

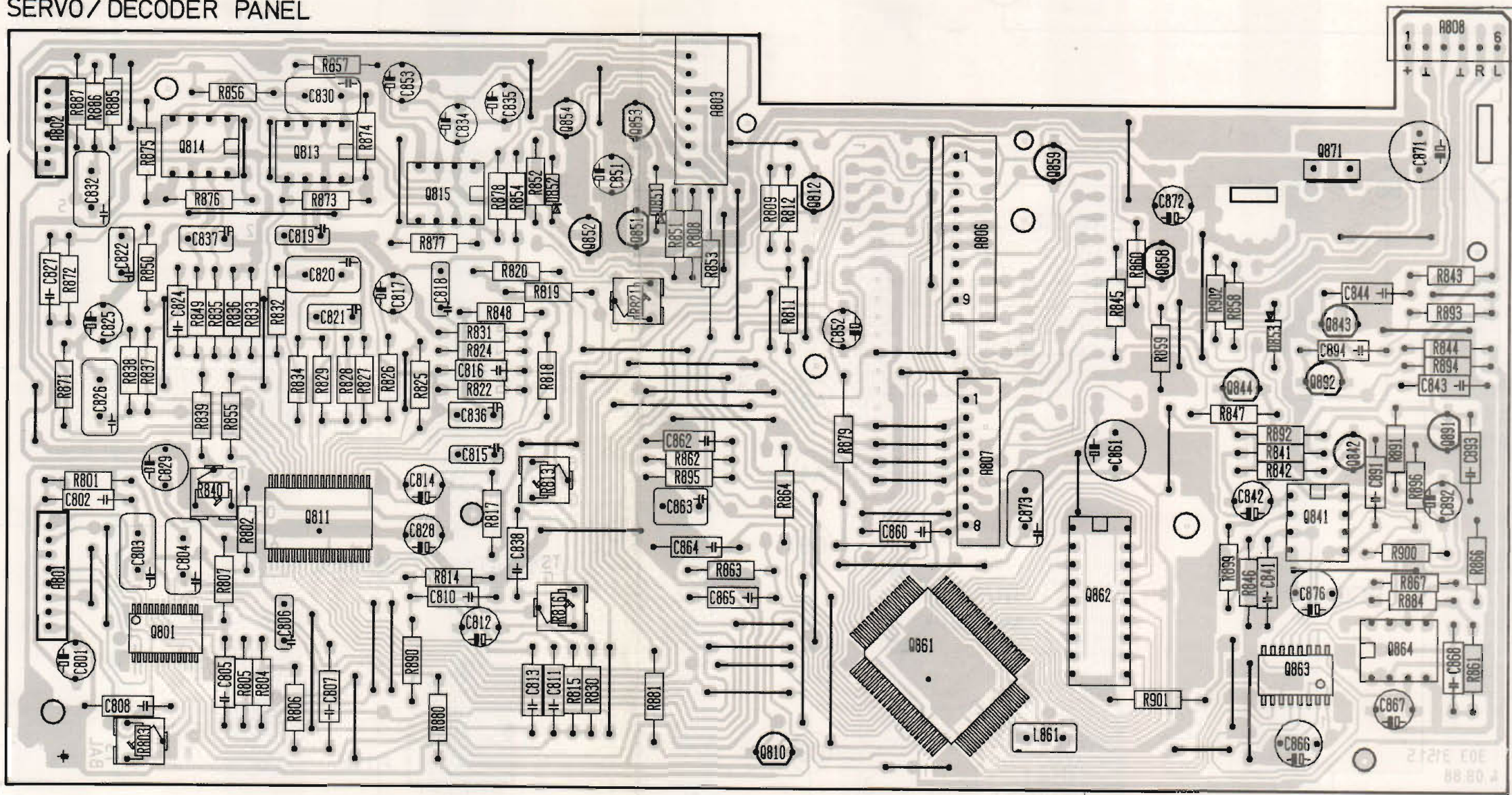

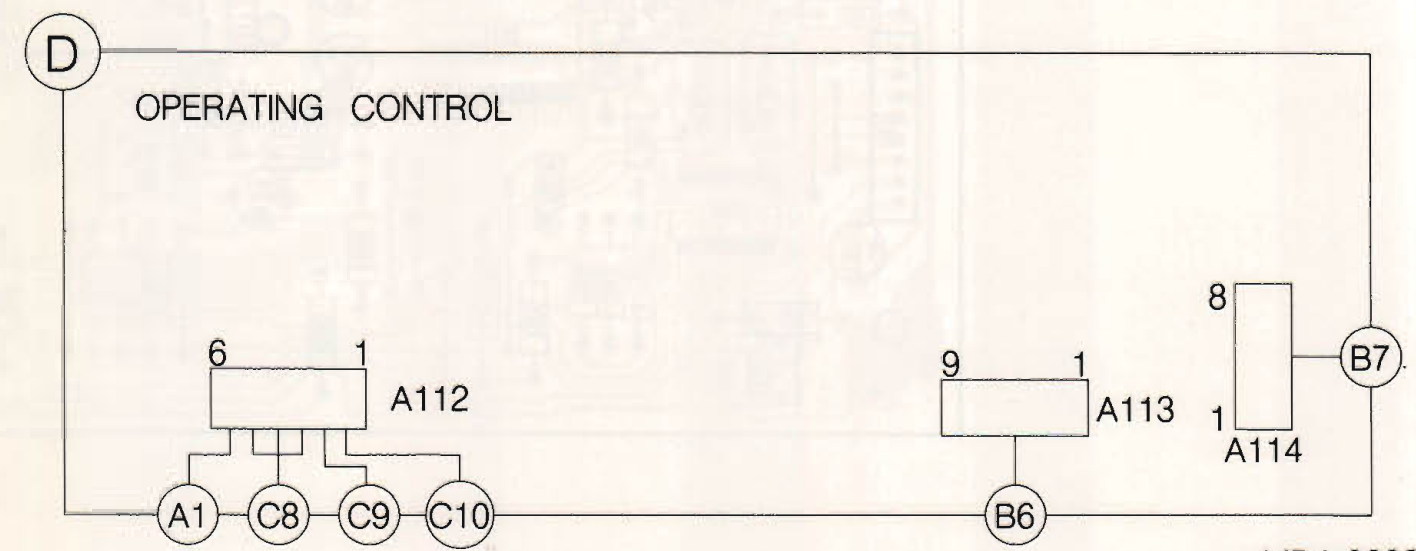
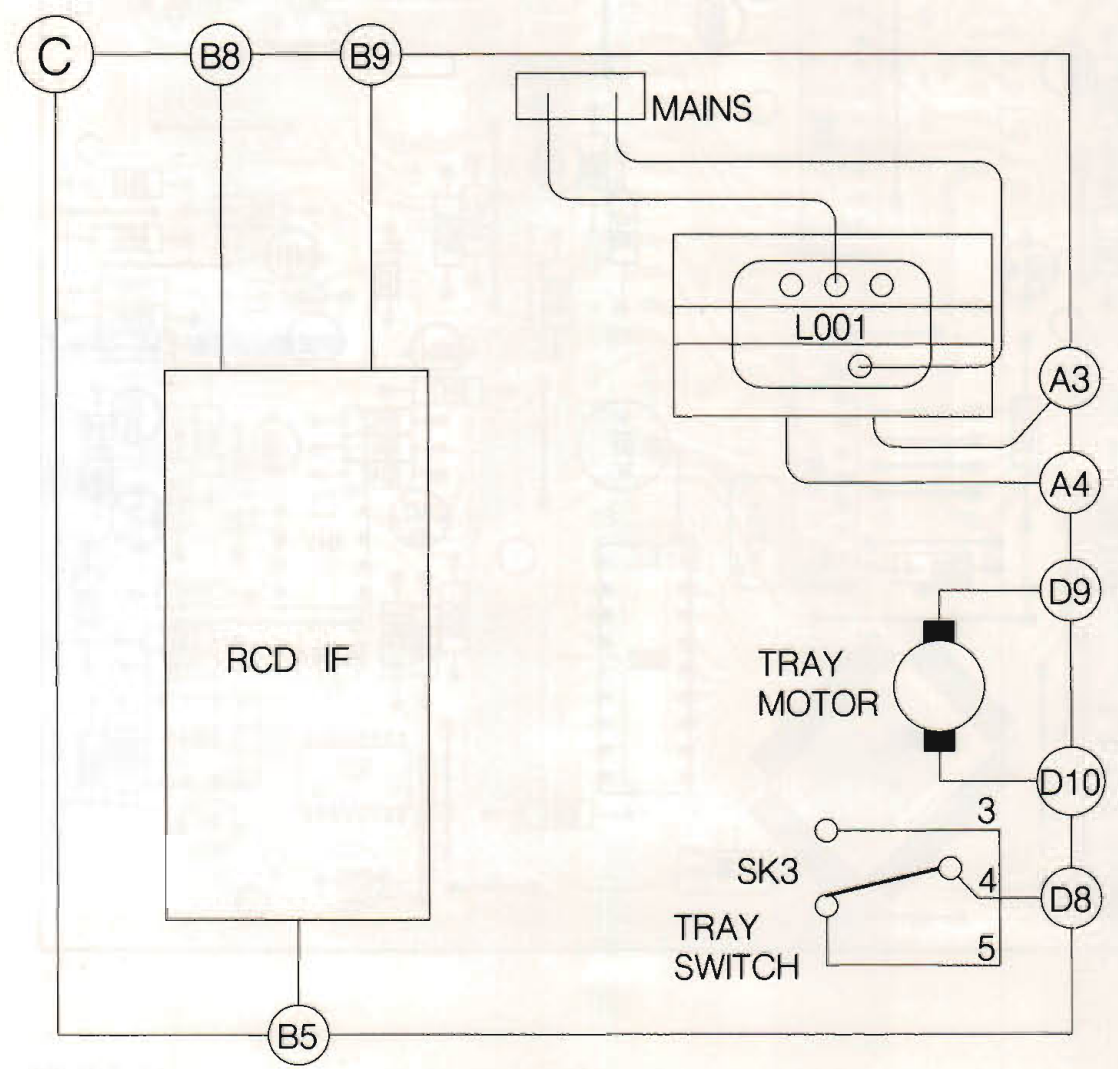
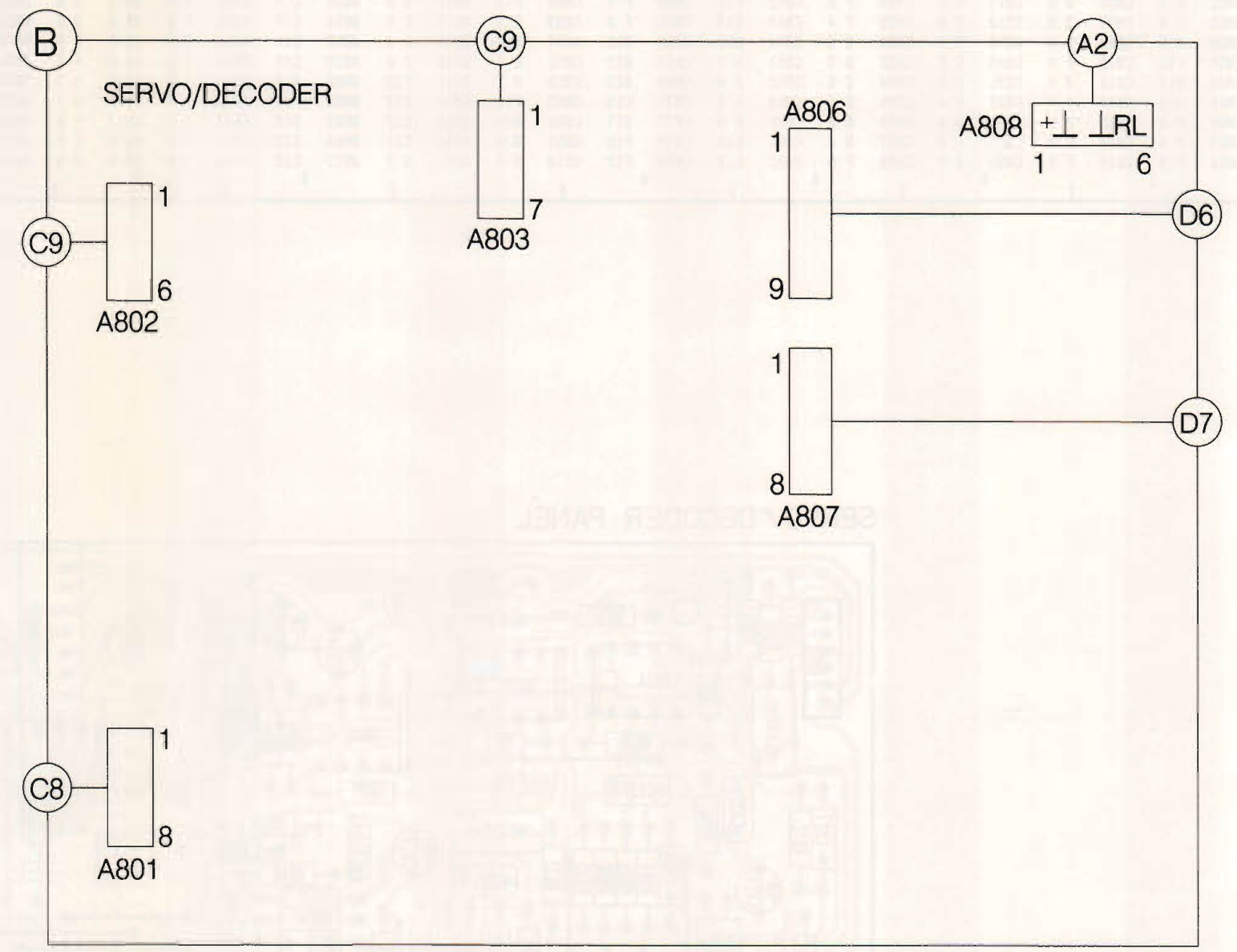
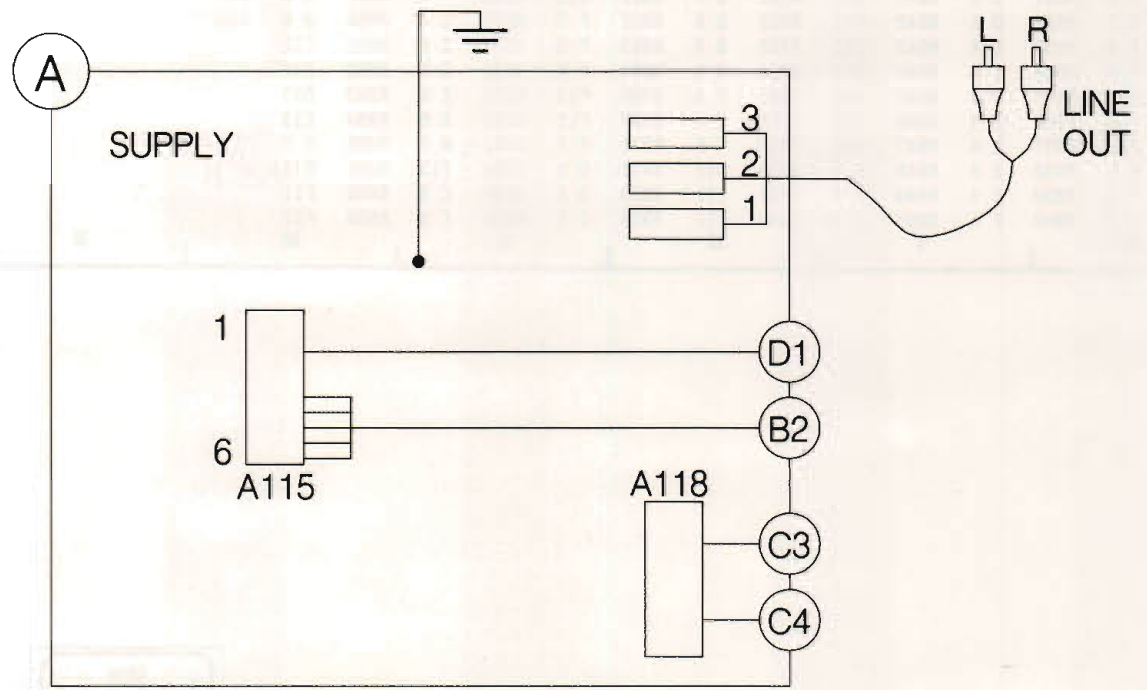

**GB Required test instruments and tools**

Oscilloscope	
LF tone generator	
AC millivoltmeter	
Universal meter	
Test disc No. 5	4822 397 30085
Torx screwdrivers	4822 395 50145
Disc hold-down	4822 532 60906

**Service test**

For testing microprocessor, display and servo, the microprocessor can be placed in the service position.

**1 Service position "0"**

This position is reached by keeping the display and shuffle switches pressed while switching the set on.

- The display shows "--".  
If this sign does not appear on the display, it is 80% sure that the microprocessor is defective.
- Display test  
When the open/close switch is pressed, the disc tray will slide out.  
The display will light up completely, as will the repeat and shuffle LEDs.  
Pressing the open/close switch again causes the tray to slide in again and the display and LEDs to go out.  
Besides the display, a number of I/O gates will be tested with this test.

**2 Service position "1"**

To achieve service position "1", one should press the play switch after service position "0".

- The display keeps on showing "--".
- Focussing test  
If there is no disc on the turntable and the play switch is pressed, the light pen will move up and down twice.  
If there is a disc on the turntable and the play switch is pressed, the laser and the focus control will be working and the motor will be running.  
The light pen stays below the lead-in tracks.

**3 Service position "2"**

You can put the player in service position "2" by pressing the introscan switch after service position "0" or "1".

- Test disc on turntable.
- The display shows " - - ".
- Radial servo test
- As soon as the introscan switch has been pressed, the music track will be played back.  
If now the next or previous switch is pressed, the light pen will jump about 40 tracks forward or backward.

One can return to service position "0" by pressing the stop switch. One can leave the service position by switching the set off.

**NL Benodigde meetinstrumenten en hulpmiddelen**

Oscilloscoop	
LF toongenerator	
AC millivoltmeter	
Universeelmeter	
Testplaat No. 5	4822 397 30085
Torx schroevendraaiers	4822 395 50145
Aandrukker	4822 532 60906

**Service test**

De  $\mu$ -processor kan in de servicestand gezet worden om de  $\mu$ -processor, display en servo te testen.

**1. Service pos. "0"**

Deze wordt bereikt door de schakelaars display en shuffle ingedrukt te houden en gelijktijdig het apparaat in te schakelen.

- Display geeft "--".  
Indien dit niet op het display verschijnt is het voor 80% zeker dat de  $\mu$ -processor defect is.
- Display test  
Door indrukken van de schakelaar open/close zal de lade naar buiten worden geschoven.  
Het display zal volledig oplichten, alsmede de leds repeat en shuffle.  
Opnieuw indrukken van de schakelaar open/close doet de lade naar binnen schuiven en het display en leds doen uitgaan.  
Naast de display test zal hiermede tevens nog een aantal I/O poorten worden getest.

**2. Service pos. "1"**

Om in service pos. "1" te geraken dient men na service pos. "0" op schakelaar play te drukken.

- Display blijft "--" aangegeven
- Focusering test  
Zonder plaat op de draaitafel zal bij indrukken van de schakelaar play de lichtpen 2x op en neer bewegen.  
Met een plaat op de draaitafel zal bij indrukken van de schakelaar play de laser en de focusregeling werken en draait de motor.  
De lichtpen blijft continu onder de aanloopsporen staan.

**3. Service pos. "2"**

Door na service pos. "0" of "1" op schakelaar introscan te drukken zal de speler in de service pos. "2" worden gezet.

- Testplaat op draaitafel
- Display geeft " - - "
- Radiaal servo test.  
Na het indrukken van de schakelaar introscan zal onmiddellijk het muziekspoor worden weergegeven.  
Door nu de schakelaar next of previous in te drukken zal de lichtpen  $\pm$  40 sporen vooruit of terug springen.

Door de schakelaar stop in te drukken komt men terug in de service pos. "0". Men kan uit de servicestand geraken door het apparaat uit te schakelen.

## F Instruments de mesure requis et auxiliaires

Oscilloscope	
Générateur BF	
Millivoltmètre AC	
Disque de test n°5	4822 397 30085
Tournevis Torx	4822 395 50145
Presseur	4822 532 60906

### Test Service

Le  $\mu$ P peut être branché en position service afin de pouvoir tester le  $\mu$ P, l'afficheur et l'asservissement.

#### 1. Position Service "0"

Maintenir enfoncé les commutateurs "display" et "shuffle" et allumer simultanément l'appareil.

- L'afficheur donne: "--"
  - Si ce signal n'apparaît pas, il y a 80% de chances que le  $\mu$ P est défectueux.
- Test de l'afficheur
  - En appuyant sur la touche open/close, le plateau glissera vers l'extérieur.
  - L'afficheur s'allumera ainsi que les DEL "repeat" et "shuffle".
  - Presser encore une fois le commutateur open/close, le plateau rentrera et l'afficheur ainsi que les DEL s'éteignent.
  - Outre à l'afficheur, un certain nombre de portes E/S sont également testées.

#### 2. Position Service "1"

A partir de la position de service "0" on appelle la position de service "1" en appuyant sur la touche "play".

- Le "--" se maintient à l'afficheur.
- Test de focalisation
  - S'il n'y a pas de disque sur le plateau, le laser se déplacera deux fois de haut en bas.
  - Lorsqu'il y a un disque sur le plateau, le laser et le régale de focalisation fonctionneront et le moteur tournera.
  - Le laser se maintiendra en permanence sous la piste d'amorçage.

#### 3. Position Service "2"

En appuyant sur la touche "introscan" à partir de la position de service "0" ou "1", l'appareil sera mis dans la position service "2".

- Mettre le disque d'essai sur le plateau.
- L'afficheur indique "--".
- Test d'asservissement radial
  - Après avoir appuyé sur la touche introscan, la piste de musique sera immédiatement reproduite.
  - En pressant alors soit la touche "next", soit la touche "previous", le laser avancera, respectivement, reculera de +/- 40 pistes.

A l'aide du commutateur "stop" on revient à la position de service "0".  
On quitte les positions de service en éteignant l'appareil.

## D Benötigte Messgeräte und Hilfsmittel

Oszilloskop	
NF-Tongenerator	
Millivoltmeter	
Universalmessgerät	
Prüfplatte Nr. 5	4822 397 30085
Torx-Schraubenzieher	4822 395 50145
Anpresser	4822 532 60906

### Service-Prüfung

Zum Prüfen des  $\mu$ P-Display und Servos lässt sich der Mikroprozessor in die Servicestellung bringen.

#### 1. Servicestellung "0"

Sie wird durch Niederhalten der Schalter "display" und "shuffle" und gleichzeitiges Einschalten des Geräts erreicht.

- Display stellt "--" dar.
  - Wenn dies nicht auf dem Display erscheint, hat der Mikroprozessor mit 80%iger Wahrscheinlichkeit Schaden genommen.
- Display-Prüfung
  - Durch Drücken des Schalters "open/close" wird die Lade ausgefahren werden.
  - Das Display wird voll aufleuchten, sowie die Leuchtdioden "repeat" und "shuffle".
  - Erneutes Drücken des Schalters "open/close" lässt die Laden einfahren und das Display und die Leuchtdioden erlöschen.
  - Ausser der Display-Prüfung werden damit gleichzeitig noch einige E/A-Tore geprüft werden.

#### 2. Servicestellung "1"

Um in die Servicestellung "1" zu geraten, muss man nach Servicestellung "0" den Schalter "play" drücken.

- Display stellt nach wie vor "--" dar.
  - Ohne Platte auf dem Plattenteller wird sich beim Drücken des Schalters "play" der Lichtstift 2x hin und her bewegen.
  - Mit einer Platte auf dem Plattenteller wird beim Drücken des Schalters "play" der Laser und die Fokusregelung arbeiten und läuft der Motor.
  - Der Lichtstift bleibt dauernd unter den Anlaufspuren stehen.

#### 3. Servicestellung "2"

Dadurch dass nach Servicestellung "0" oder "1" Schalter "introscan" gedrückt wird, wird der Spieler in die Servicestellung "2" gebracht werden.

- Prüfplatte auf Plattenteller.
- Display zeigt "--" an.
- Radialservoprüfung
  - Nach Drücken des Schalters "introscan" wird sofort die Musikspur wiedergegeben werden.
  - Dadurch dass nun der Schalters "next" oder "previous" gedrückt wird, wird der Lichtstift ca. 40 Spuren voraus oder zurückspringen. Durch Drücken des Schalters "stop" gelangt man wieder in die Servicestellung "0"

Durch Ausschalten des Geräts wird die Servicestellung verlassen.

**I** **Instrumenti metrologici e ausiliari**

Oscilloscopio  
 Generatore BF  
 Millivoltmetro AC  
 Disco di prova n°5 4822 397 30085  
 Cacciavite Torx 4822 395 50145  
 Pressore 4822 532 60906

**Test di servizio**

Il  $\mu P$  sarà inestato in posizione di servizio in modo di poter testare il  $\mu P$ , il display e il servo.

**1. Posizione di Servizio "0"**

- Mantenere i commutatori "display" e "shuffle" spinti mentre si accende l'apparecchio.
- Il display indica: "--"
- Se questo segnale non compare, esiste 80% di probabilità che il  $\mu P$  è difettoso.
- Prova del display  
 Spingendo sul tasto open/close, il piatto sarà spinto verso fuori.  
 Il display si accende così come i DEL "repeat" e "shuffle".  
 premere un'altra volta il tasto open/close, il piatto rientra e il display così come i DEL si spengono.  
 Oltre al display, alcune porte I/U vengono sottoposte alle prove.

**2. Posizione di Servizio "1"**

- Dalla posizione di servizio "0" si chiama la posizione di servizio "1" premendo il tasto "play".
- Il "--" si mantiene al display.
- Prova di focalizzazione  
 Se il piatto è vuoto, il laser si sposterà due volte insù e ingiù.  
 Se vi è un disco sul piatto, il laser e il comando di focalizzazione funzioneranno e il motore girerà.  
 Il laser si manterrà costantemente sotto la traccia d'inizio.

**3. Position Service "2"**

- Se si preme sul tasto "introscan" dalla posizione di servizio "0" o "1", l'apparecchio sarà portato in posizione di servizio "2".
- Mettere un disco di prova sul piatto.
- Il display fa comparire "---
- Test servo-radiale  
 Dopo aver premuto il tasto introscan, la traccia di musica sarà letta subito.  
 Premendo sia sul tasto "next", sia il tasto "previous", il laser proseguirà o retrocederà di +/- 40 tracce.
- Per mezzo del "stop" si torna in posizione di servizio "0".  
 Si lascia le posizioni di servizio mentre si mette l'apparecchio fuori funzione.

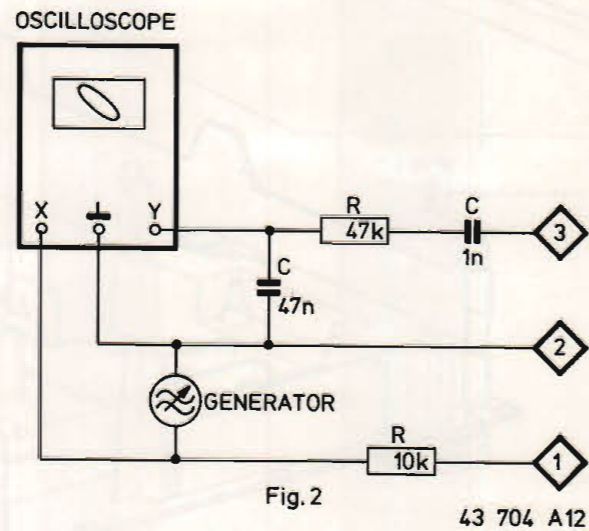
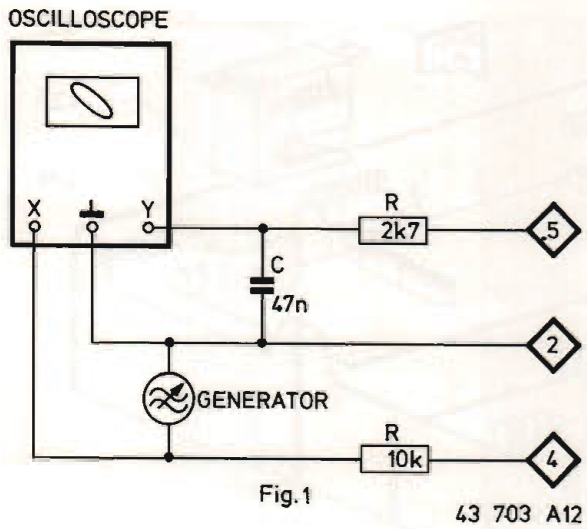

CD part					
<b>TRACKING OFFSET</b>					
Stop			R840		0 V $\pm$ 10 mV
<b>TRACKING BALANCE</b>					
Service* pos. 1 display "--"			R803		Adjust to 0 V DC offset
<b>TRACKING GAIN</b>					
Play with disc 5	1200 Hz 200 mV	see Fig. 1	R816		See Fig. 1 CHX = 0,2 V/DIV CHY = 50 mV/DIV Adjust to circle
<b>FOCUS GAIN</b>					
Play with disc 5	1100 Hz 700 mV	See Fig. 2	R813		See Fig. 2 CHX = 0,5 V/DIV CHY = 5 mV/DIV Adjust to circle
<b>FOCUS OFFSET</b>					
Play with disc 5			R821		Max HF
			Check only		U DC measured = Ux
			R821		Adjust to $\frac{Ux}{2}$

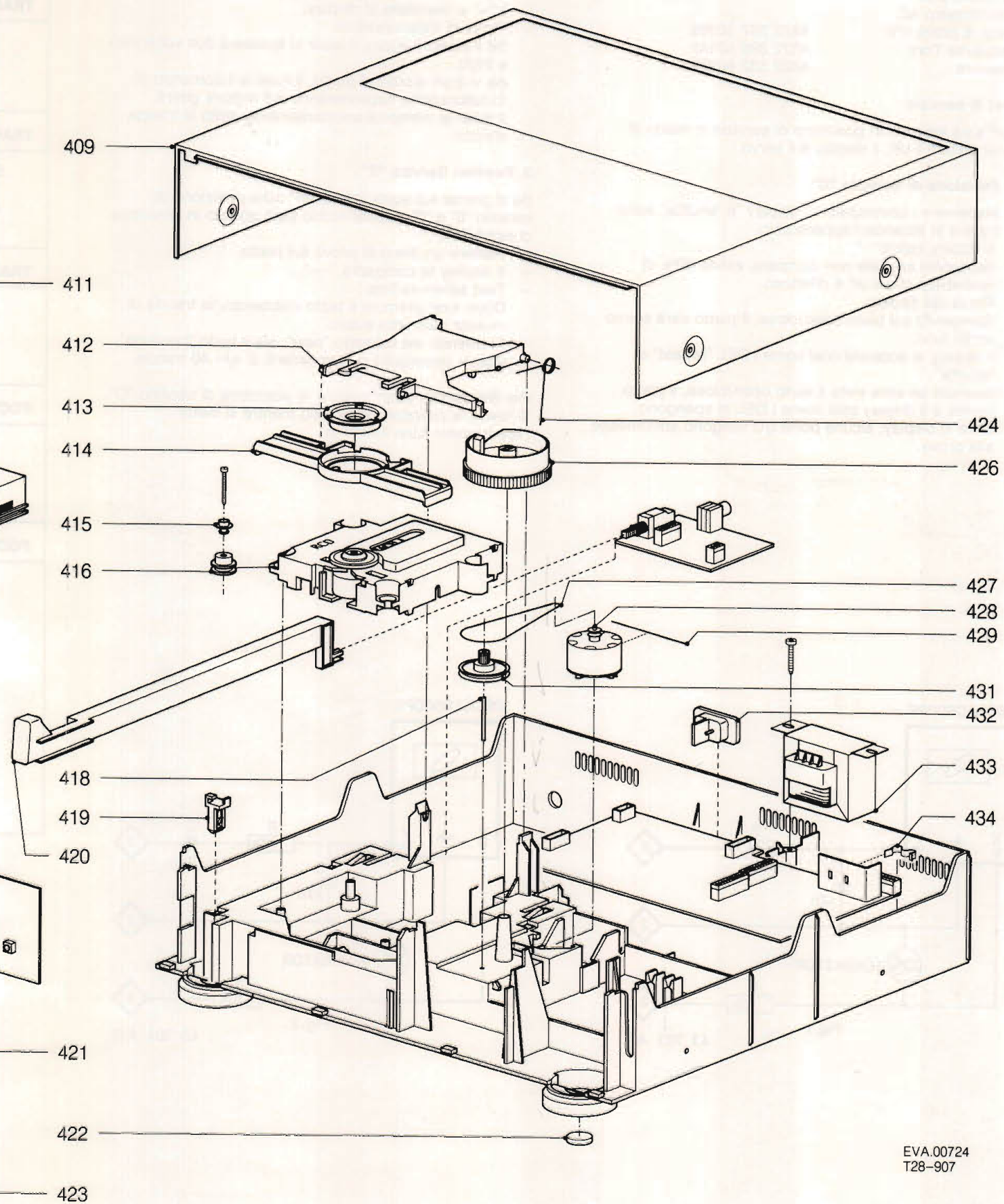
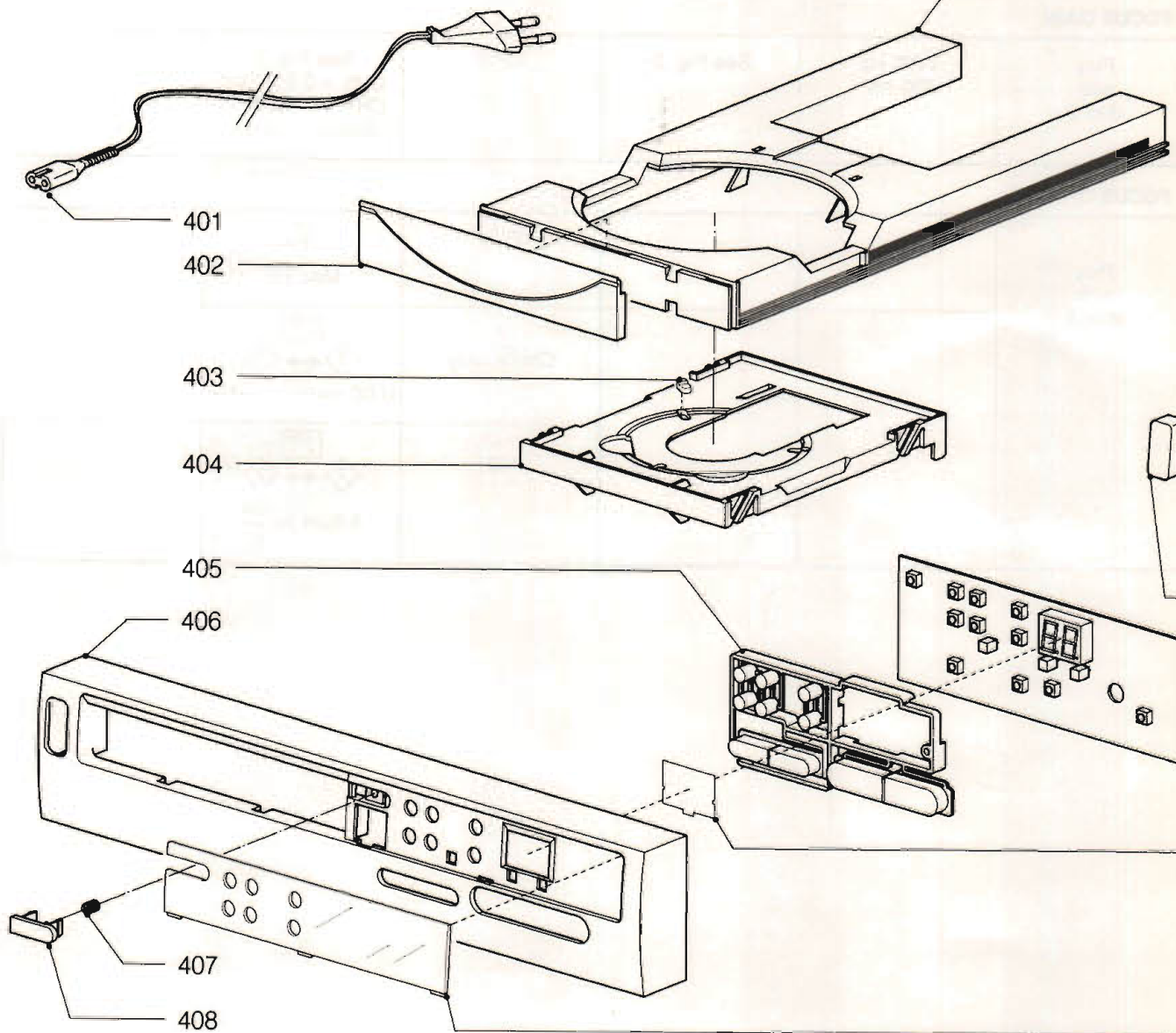



AK696/17  
AK698/17

Service  
Service  
Service

For repair information of the C.D. mechanism see Service Manual RCD IF

# Service Manual

## SUPPLEMENT

AK691/60 is identical to AK691/00  
AK691/65 is identical to AK691/05

This supplement describes the changes due to a modified driver circuitry of the C.D. mechanism.  
For missing data see service manual 4822 725 22337 of AK691

Q813	Q814	4822 209 61073	TDA7073
A810	△	4822 071 56301	630MAT
Q110		4822 209 60758	LTD-6810Y
Q120		4822 209 72214	TMP47C400AF



CD part	⊗	◇	↻	⊞	⊞
<b>TRACKING OFFSET</b>					
Stop			R840		⊞ ↔ ⊞ 0 V ± 10 mV
<b>TRACKING BALANCE</b>					
Service* pos. 1 display "_"			R803	⊞ ↔ ⊞	Adjust to 0 V DC offset
<b>TRACKING GAIN</b>					
Play with disc 5	1200 Hz 200 mV	see Fig. 1	R816		See Fig. 1 CHX = 0,2 V/DIV CHY = 50 mV/DIV Adjust to circle
<b>FOCUS GAIN</b>					
Play with disc 5	1100 Hz 700 mV	See Fig. 2	R813		See Fig. 2 CHX = 0,5 V/DIV CHY = 5 mV/DIV Adjust to circle
<b>FOCUS OFFSET</b>					
Play with disc 5			R821		⊞ Max HF
			Check only	⊞ ↔ ⊞	U DC measured = U <sub>x</sub>
			R821	⊞ ↔ ⊞	Adjust to $\frac{U_x}{2}$

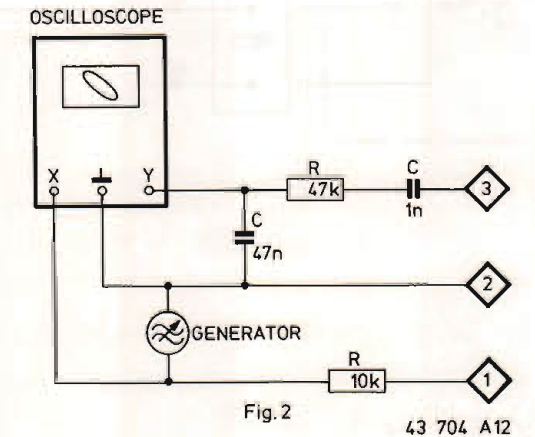
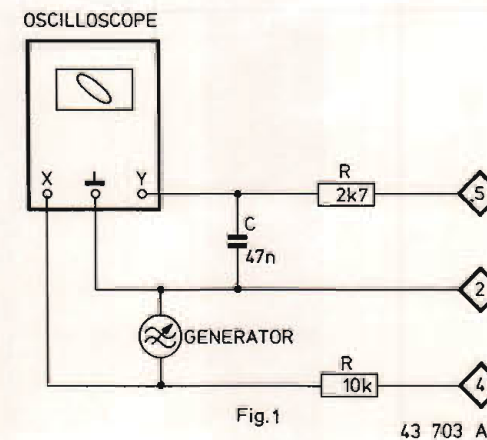



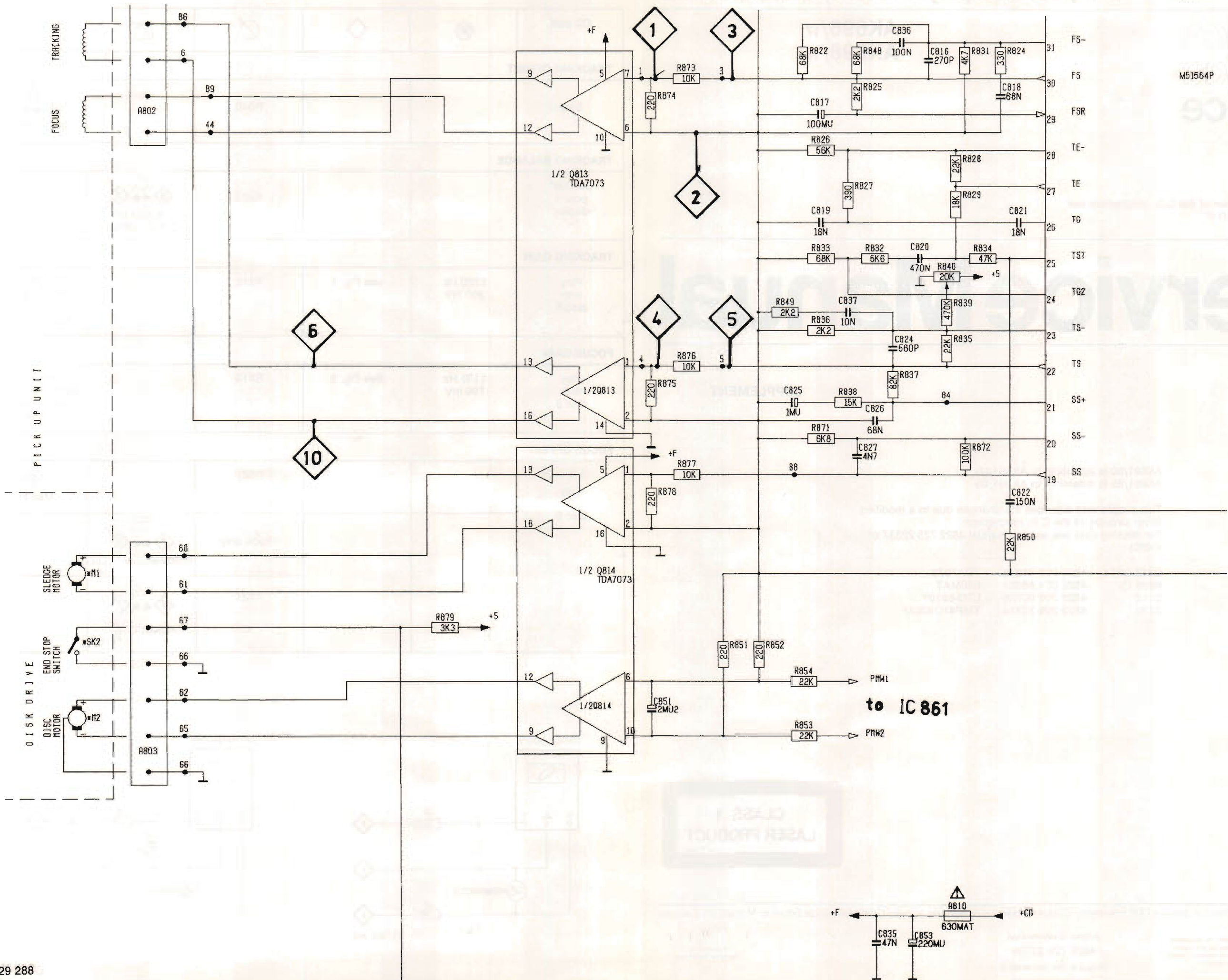

R801	C 3	C803	C 4	C813	B 6	C822	E 3	C837	E 4	C860	C 9	C871	F13	L861	B10	Q843	D12	Q891	D13	R809	E 8	R819	E 6	R829	D 5	R838	D 4	R847	D11	R859	D11	R872	E 3	R881	B 7	R899	C11
R802	F 3	C804	C 4	C814	C 6	C824	E 4	C838	C 6	C861	D10	C872	E11	Q801	B 4	Q844	D11	Q892	D12	R811	E 8	R820	E 6	R830	B 7	R839	D 4	R848	E 6	R860	E11	R873	E 4	R884	C13	R900	C12
R803	F 8	C805	B 4	C815	D 6	C825	D 3	C841	C11	C862	D 7	C873	C10	Q810	A 8	Q858	E11	R801	C 3	R812	E 8	R821	E 7	R831	D 6	R840	C 4	R849	E 4	R861	B13	R874	F 5	R890	B 6	R901	B11
R806	E 9	C806	B 5	C816	D 6	C826	D 3	C842	C11	C863	C 7	C876	C12	Q811	C 5	Q859	F10	R802	C 4	R813	C 6	R822	D 6	R832	E 5	R841	D12	R850	E 4	R862	D 7	R875	F 3	R891	D12	R902	E11
R807	C10	C807	B 5	C817	E 5	C827	E 3	C843	D13	C864	C 7	C891	C12	Q812	E 8	Q861	B 9	R803	B 4	R814	C 6	R824	D 6	R833	E 4	R842	C12	R851	E 6	R863	C 8	R876	E 3	R892	D12		
R808	D13	C808	B 3	C818	E 6	C828	C 6	C844	E12	C865	C 8	C892	C13	Q813	F 4	Q862	C10	R804	B 4	R815	B 7	R825	D 6	R834	D 5	R843	E13	R852	E 6	R864	C 8	R877	E 5	R893	E13		
R810	E 7	C810	C 6	C819	E 5	C829	C 4	C851	E 7	C866	B12	C893	D13	Q814	F 6	Q863	B12	R805	B 4	R816	B 7	R826	D 5	R835	E 4	R844	D13	R853	E 8	R866	C13	R878	E 5	R894	D13		
C801	B 3	C811	B 6	C820	E 5	C835	F 5	C852	D 8	C867	B12	C894	D12	Q841	C12	Q864	B12	R806	B 5	R817	C 6	R827	D 5	R836	E 4	R845	E10	R854	D 7	R867	C13	R879	D 9	R895	C 7		
C802	C 3	C812	B 6	C821	D 5	C836	D 6	C853	F 7	C868	B13	D853	D12	Q842	D12	Q871	F12	R807	C 4	R818	D 6	R828	D 5	R837	D 4	R846	C11	R858	E11	R871	D 3	R880	B 6	R896	C13		

