

Portable Compact Disc Player

Service
Service
Service

AX1000
AX1001
all versions

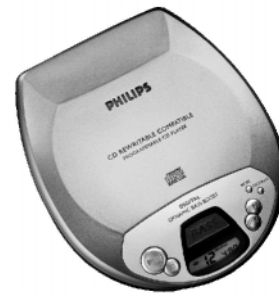

Service Manual



TABLE OF CONTENTS

	chapter		chapter
Handling chip components and safety	1 - 1	CIRCUIT DIAGRAMS	
Technical Specification	2 - 1	Control/Supply part.....	4 - 1
Measurement Setup.....	2 - 1	Audio part.....	4 - 2
Connections & Controls	2 - 2	CD part.....	4 - 3
Instructions for use	2 - 3 to 2 - 7	LAYOUT DIAGRAMS	
Accessories	2 - 8	Component Side View.....	4 - 4
Service Tools.....	2 - 8	Copper Side View.....	4 - 5
Block Diagram.....	3 - 1	Exploded View Diagram.....	5 - 1
Startup Procedure	3 - 2	Mechanical partslist	5 - 1
Pinning of Intergated Circuits	3 - 2	Electrical partslist	6 - 1 to 6 - 3

Safety regulations require that the set be restored to its original condition and that parts which are identical with those specified be used.

© Copyright 1995 Philips Consumer Electronics B.V. Eindhoven, The Netherlands
All rights reserved. No part of this publication may be reproduced, stored in a retrieval system or transmitted, in any form or by any means, electronic, mechanical, photocopying, or otherwise without the prior permission of Philips.



Published by SS 0106 Service Audio Printed in The Netherlands Copyright reserved Subject to modification GB 3140 785 22550

PCS 107 185



PHILIPS

HANDLING CHIP COMPONENTS

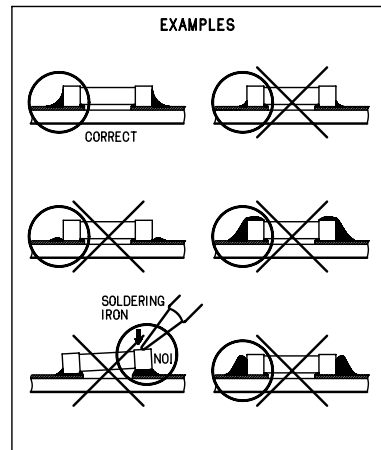
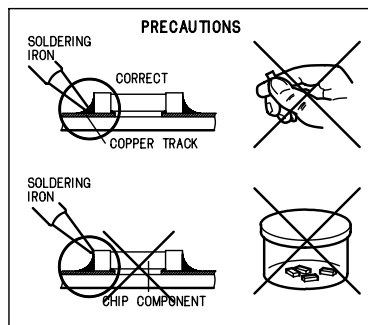
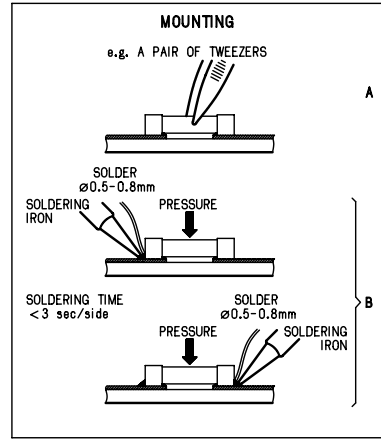
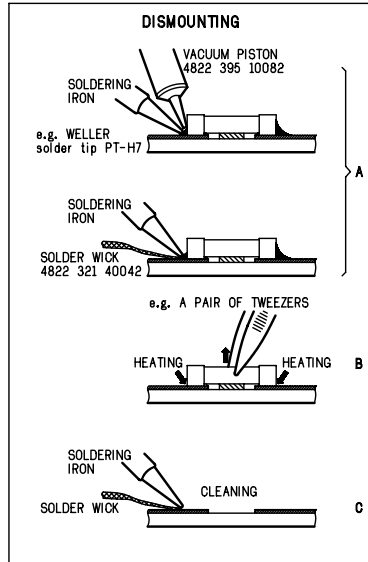
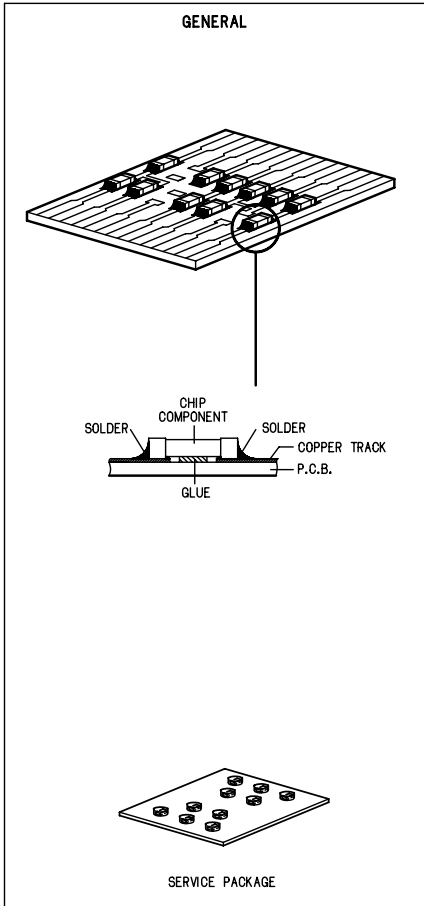

(GB) WARNING

All ICs and many other semiconductors are susceptible to electrostatic discharges (ESD). Careless handling during repair can reduce life drastically. When repairing, make sure that you are connected with the same potential as the mass of the set via a wristband with resistance. Keep components and tools at this potential.

ESD



(NL) WAARSCHUWING

Alle IC's en vele andere halfgeleiders zijn gevoelig voor electrostatische ontladingen (ESD). Onzorgvuldig behandelen tijdens reparatie kan de levensduur drastisch doen verminderen. Zorg ervoor dat u tijdens reparatie via een polsband met weerstand verbonden bent met hetzelfde potentiaal als de massa van het apparaat. Houd componenten en hulpmiddelen ook op ditzelfde potentiaal.

(F) ATTENTION

Tous les IC et beaucoup d'autres semi-conducteurs sont sensibles aux décharges statiques (ESD). Leur longévité pourrait être considérablement écourtée par le fait qu'aucune précaution n'est prise à leur manipulation. Lors de réparations, s'assurer de bien être relié au même potentiel que la masse de l'appareil et enfilier le bracelet serti d'une résistance de sécurité. Veiller à ce que les composants ainsi que les outils que l'on utilise soient également à ce potentiel.

(D) WARNUNG

Alle ICs und viele andere Halbleiter sind empfindlich gegenüber elektrostatischen Entladungen (ESD). Unvorsichtige Behandlung im Reparaturfall kann die Lebensdauer drastisch reduzieren. Sorgen Sie dafür, daß Sie im Reparaturfall über ein Pulsarmband mit Widerstand mit dem Massepotential des Gerätes verbunden sind. Halten Sie Bauteile und Hilfsmittel ebenfalls auf diesem Potential.

(I) AVVERTIMENTO

Tutti IC e parecchi semi-conduttori sono sensibili alle scariche statiche (ESD). La loro longevità potrebbe essere fortemente ridotta in caso di non osservazione della più grande cauzione alla loro manipolazione. Durante le riparazioni occorre quindi essere collegato allo stesso potenziale che quello della massa dell'apparecchio tramite un braccialeto a resistenza. Assicurarsi che i componenti e anche gli utensili con quali si lavora siano anche a questo potenziale.

(GB)

Safety regulations require that the set be restored to its original condition and that parts which are identical with those specified be used. Safety components are marked by the symbol

(F)

Les normes de sécurité exigent que l'appareil soit remis à l'état d'origine et que soient utilisées les pièces de rechange identiques à celles spécifiées. Les composants de sécurité sont marqués

SAFETY



(D)

Bei jeder Reparatur sind die geltenden Sicherheitsvorschriften zu beachten. Der Originalzustand des Gerätes darf nicht verändert werden. Für Reparaturen sind Originalersatzteile zu verwenden. Sicherheitsbauteile sind durch das Symbol markiert.

(NL)

Veiligheidsbepalingen vereisen, dat het apparaat in zijn oorspronkelijke toestand wordt teruggebracht en dat onderdelen, identiek aan de gespecificeerde, worden toegepast. De Veiligheidsonderdelen zijn aangeduid met het symbool

(I)

Le norme di sicurezza estigono che l'apparecchio venga rimesso nelle condizioni originali e che siano utilizzati i pezzi di ricambio identici a quelli specificati. Componenti di sicurezza sono marcati con

(GB) DANGER: Invisible laser radiation when open. AVOID DIRECT EXPOSURE TO BEAM.

(S) Varning !
Osynlig laserstrålning när apparaten är öppnad och spårren är urkopplad. Betrakta ej strålen.

Advarsel !

Usynlig laserstrålning ved åbning når sikkerhedsafbrydere er ude af funktion. Undgå udsættelse for strålning.



(FIN) Varoituis !

Avatussa laitteessa ja suojalukituksen ohitettaessa olet alttiina näkymättömälle laserisäteilylle. Älä katso säteeseen !

(GB)

After servicing and before returning the set to customer perform a leakage current measurement test from all exposed metal parts to earth ground, to assure no shock hazard exists. The leakage current must not exceed 0.5mA.

(F)

"Pour votre sécurité, ces documents doivent être utilisés par des spécialistes agréés, seuls habilités à réparer votre appareil en panne".

TECHNICAL SPECIFICATIONS

General

Dimension (W x H x D)	: 129 x 30 x 150 mm
Weight	: 220 g

Power supply modes

DC in socket	: 2.9 – 8.0 V
Primary batteries (2xLR6)	: 1.6 – 3.6 V
Rechargeable batteries	: 1.6 – 3.6 V

Battery lifetime

Battery Type	ESA OFF	ESA ON
Primary batteries 2 x LR6	15 hrs (17.5h typ.)	- -

Battery level detection

Battery empty	: 1.8 V nom. +100/-100 mV
---------------	---------------------------

Current consumption DC-in supply (4.5 V)

Operation	ESA OFF	ESA ON
Play mode	140 mA typ.	-
Jump mode	400 mA typ.	-
Standby	60 mA typ.	-

Current consumption Battery supply (2.25 V)

Operation	ESA OFF	ESA ON
Play mode	140 mA typ.	-
Jump mode	500 mA typ.	-
Standby	0.1 mA typ.	-

Shock resistance (ESA off)

+X/-X direction	: 4 G
+Y/-Y direction	: 4 G
+Z/-Z direction	: 3 G

Headphone output (16 Ohm, ESP and DBB off)

Output power (10% THD)	: 4 mW (+1/-3dB)
-/17 version only	: 2 mW (+1/-3dB)
Frequency response (1mW)	: 100Hz - 20kHz within 6 dB
S/N ratio (unw.)	: 75 dB (80 dB typ.)
S/N ratio (A-wght)	: 77 dB (82 dB typ.)
THD+N (1kHz, 1mW)	: 1 % (0.2 % typ.)
Crosstalk (1kHz, no load)	: -65 dB (-75 dB typ.)
Channel unbalance (-40dB)	: 5dB
Volume attenuation (1kHz)	: > 60 dB

Dynamic Bass Boost DBB

DBB Stage	Frequency response		
	63 kHz	1 kHz	10 kHz
DBB	+8dB ±2dB	0dB ±2dB	0dB ±2dB

Measurement setup

Use Audio Signal Disc SBC429 4822 397 30184

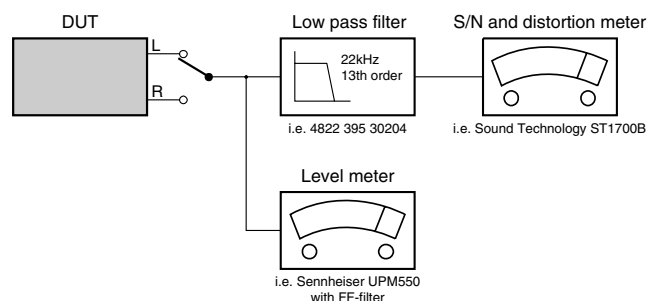

CONNECTIONS AND CONTROLS

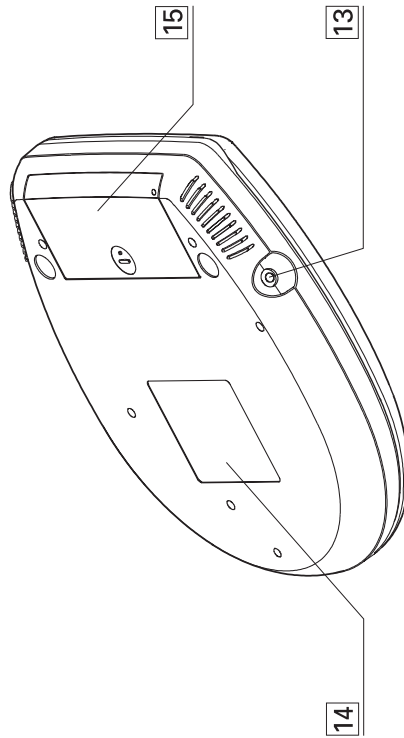
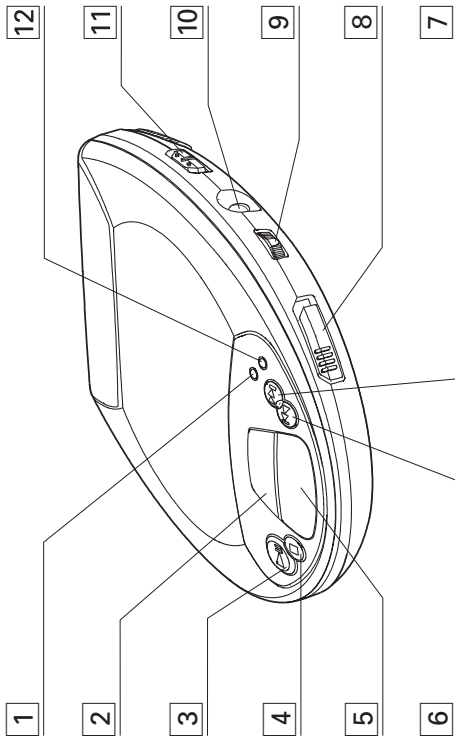

- 1 MODEselects the different playing possibilities: **SHUFFLE**, **SHUFFLE REPEAT ALL**, **REPEAT** and **REPEAT ALL**
- 2 BASSswitches the bass enhancement on and off. This button also switches acoustic feedback (the beep) on/off when it is pressed for more than 2 seconds
- 3 **▶||**switches the player on, starts or pauses CD play
- 4 **■**stops CD play, clears a program or switches the player off
- 5display
- 6skips and searches CD tracks backwards
- 7 **▶▶**skips and searches CD tracks forwards
- 8 OPEN **▶**opens the CD lid
- 9 VOL **◀▶**adjusts the volume
- 10 **⌂**/LINE OUT3.5 mm headphone socket, socket to connect the player to another audio input of an additional appliance
- 11 OFFswitches RESUME and HOLD off
RESUMEstores the last position of a CD track played
HOLDlocks all buttons
- 12 PROGRAMprograms tracks and reviews the program
- 13 4.5V DCsocket for external power supply
- 14typeplate
- 15battery compartment

This set complies with the radio interference requirements of the European Community.

INSTRUCTIONS FOR USE

Batteries (supplied or optionally available)

You can use the following batteries with this CD-player:

- normal batteries type **LR6, UM3** or **AA** (preferably Philips), or
- alkaline batteries type **LR6, UM3** or **AA** (preferably Philips).

Note: – Old and new or different types of batteries should not be used in combination. Remove batteries if they are empty or if the player is not going to be used for a long time.

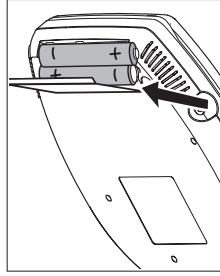

Inserting batteries

- Open the battery compartment and insert either 2 normal or alkaline batteries.



Battery indication

The approximate power level of your batteries is shown in the display.

- If  is shown or flashing (depending on the version) and  is displayed, the batteries are empty.



Mains adapter (supplied or optionally available)

Use only the AY 3170 adapter (4.5 V/300 mA direct current, positive pole to the centre pin). Any other product may damage the player.

- 1 Make sure that the adapter's voltage corresponds to the local voltage.
- 2 Connect the adapter to the 4.5V DC socket of the player and to the wall socket.

Note: Always disconnect the adapter when you are not using it.

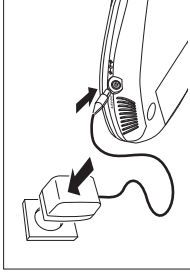

Headphones HE 545

- Connect the supplied headphones to the /LINE OUT socket of the player.

Note: /LINE OUT can also be used for connecting the player to your HiFi system (with a signal lead) or to your car radio (with a cassette adapter or signal lead). In both cases, the volume of the player must be set to position 8.

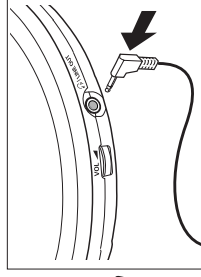

Average playing time of batteries under normal conditions

Battery type	Playing time
Normal	7 hours
Alkaline	20 hours

Batteries contain chemical substances, so they should be disposed of properly.

Use your head when using headphones

Hearing safety: Do not play your headphones at a high volume. Hearing experts advise that continuous use at high volume can permanently damage your hearing.

Traffic safety: Do not use headphones while driving a vehicle. It may create a hazard and it is illegal in many countries. Even if your headphones are an open-air type designed to let you hear outside sounds, do not turn up the volume so high that you cannot hear what is going on around you.

INSTRUCTIONS FOR USE

Playing a CD

This CD-player can play all kinds of **Audio Discs** such as CD-Recordables and CD-Rewritables. Do not try to play a CD-ROM, CDi, VCD, DVD or computer CD.

- 1 Push the OPEN ► slider to open the CD lid.
- 2 Insert an audio CD, printed side up, by pressing the CD onto the hub.
- 3 Close the player by pressing the lid down.
- 4 Press ►► to switch the player on and start playback.
 - The current track number and elapsed playing time are displayed.
- You can pause playback by pressing ►►.
 - The time at which playback was paused starts flashing.
- You can continue playback by pressing ►► again.
- 5 Press ■ to stop playback.
 - The total number of tracks and the total playing time of the CD are displayed.
- 6 Press ■ again to switch the player off.
 - To remove the CD, hold it by its edge and press the hub gently while lifting the CD.

Note: If there is no activity, the set will automatically switch off after a while to save energy.

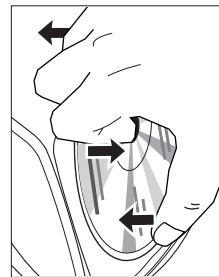
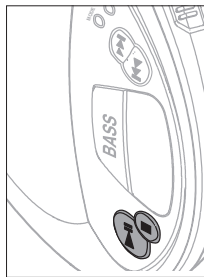
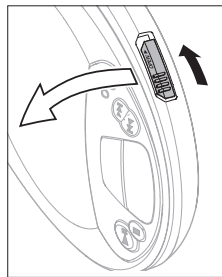
**Playback information**

- If a CD-Recordable (CD-R) or a CD-Rewritable (CD-RW) is not recorded properly, *FF* or *FF* is displayed, indicating that the CD has not been finalized. In that case, use FINALIZE on your CD recorder to complete the recording.
- When playing a CD-Rewritable (CD-RW), please note that it takes 3–15 seconds after pressing ►► for sound reproduction to start.
- Playback will stop if you open the CD lid.
- While the CD is read, *1* - *1* is displayed.

Volume and bass**Volume adjustment**

- Adjust the volume by using VOL. ►

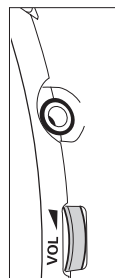
**Bass adjustment**

- Press BASS to switch the bass enhancement on or off
 - **DBB** is shown if the bass enhancement is activated.

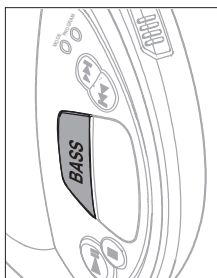

Selecting a track and searching

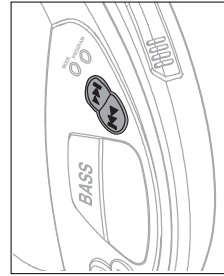

Selecting a track during playback

- Briefly press **◀▶** once or several times to skip to the current, previous or next track.
 - Playback continues with the selected track, and the track's number is displayed.

Selecting a track when playback is stopped

1 Briefly press **◀▶** once or several times to select the desired track. The track number is displayed.

2 Press **▶▶** to start CD play.

- Playback starts with the selected track.

Searching for a passage during playback

1 Keep **▶▶** pressed to find a particular passage in a backward or forward direction.

- Searching starts while playback continues at low volume. After 2 seconds the search speeds up.

2 Release the button when you reach the desired passage.

- Playback continues from this position.

Notes: – In SHUFFLE, SHUFFLE REPEAT ALL or REPEAT mode (see MODE chapter), or while playing a program, searching is only possible within the particular track.

Programming track numbers

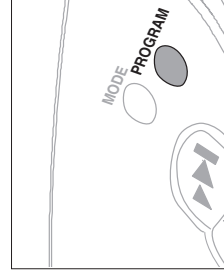

You can store up to 15 tracks to play in a program. A single track may be stored more than once in the program.

- 1** While playback is stopped, select a track with **◀▶** or **▶▶**.
- 2** Press **PROGRAM** to store the track.
 - **PROGRAM** lights up; the track number programmed and **1** with the total number of stored tracks are displayed.
- 3** Select and store all desired tracks in this way.
- 4** Press **▶▶** to start playback of your selected tracks.
 - **PROGRAM** is shown and playback starts.



- You can review the program by pressing **PROGRAM** for more than 2 seconds.
 - The display shows all the stored tracks in sequence.

Notes: – If you press PROGRAM and there is no track selected, 5 5 5 5 5 5 is displayed.
 – If you try to store more than 15 tracks, F U L L is displayed.

Clearing the program

- While playback is stopped, press **■** to clear program.
 - **5 5 5 5 5 5** is displayed once, **PROGRAM** goes off, and the program is cleared.



Note: The program will also be cleared if the power supply is interrupted, or if the CD-player lid is opened, or if the set switches off automatically.

Selecting different playing possibilities – MODE

It is possible to play tracks in random order, to repeat a single track or the entire CD.

- 1 Press MODE during playback as often as required in order to activate one of the following 'modes'. The active mode is shown in the display.
 - **SHUFFLE**: All tracks of the CD are played in random order until all of them have been played once.
 - **SHUFFLE REPEAT ALL**: All tracks of the CD are played repeatedly in random order.
 - **REPEAT**: The current track is played repeatedly.
 - **REPEAT ALL**: The entire CD is played repeatedly.

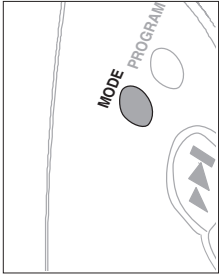

- 2 Playback starts in the chosen mode after 2 seconds.

- To return to normal playback, press MODE repeatedly until the display shows no active modes.

RESUME and HOLD

You can interrupt playback and continue (even after an extended period of time) from the position where playback stopped (RESUME) and you can lock all buttons of the set so that no action will be executed (HOLD). Use the RESUME–HOLD–OFF slider for these functions.

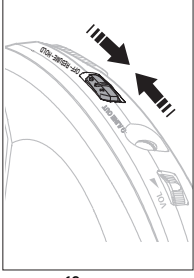

RESUME – continuing from where you have stopped

- 1 Switch the slider to RESUME during playback to activate RESUME.
 - RESUME is shown.
 - 2 Press ■ whenever you want to stop playback.
 - 3 Press ►|| whenever you want to resume playback.
 - RESUME is shown and playback continues from where you have stopped.
- To deactivate RESUME, switch the slider to OFF.
 - RESUME goes off.



HOLD – locking all buttons

You can lock the buttons of the set by switching the slider to HOLD. Now, when a key is pressed, no action will be executed. This is of use, for example, when transporting the player in a bag. With HOLD activated, you can avoid accidental activation of other functions.

- 1 Switch the slider to HOLD to activate HOLD.
 - All buttons are locked. HOLD is shown when you press any button. If the set is switched off, HOLD will be shown only when ►|| is pressed.
- 2 To deactivate HOLD, switch the slider to OFF.



Note: If you deactivate HOLD by switching the slider to RESUME, you will be activating the RESUME function.

INSTRUCTIONS FOR USE

WARNING

Under no circumstances should you try to repair the set yourself as this will invalidate the guarantee.

If a fault occurs, first check the points listed, before taking the set for repair. If you are unable to solve a problem by following these hints, consult your dealer or service centre.

Problem	Possible cause	Solution
No power, playback does not start	Batteries Batteries inserted incorrectly Batteries are empty. Contact pins are dirty.	Insert the batteries correctly. Change the batteries. Clean them with a cloth.
	Mains adapter Loose connection	Connect the adapter securely.
RF indication	CD-RW (CD-R) is not recorded properly.	Use FINALIZE on the CD recorder to complete the recording.
RF indication	The CD is badly scratched or dirty. CD is not or incorrectly inserted. The laser lens is steamed up.	Replace or clean the CD. Insert a CD, label upwards. Wait until the lens has cleared.
Hold indication and/or no reaction to controls	HOLD is activated. Electrostatic discharge	Deactivate HOLD. Disconnect the set from power supply or take out the batteries for a few seconds.
	No sound or bad sound quality	PAUSE is activated. Loose, wrong or dirty connections Volume is not adjusted. Malfunctions due to nearness of active mobile phones Strong magnetic fields near the player
	The CD skips tracks.	The CD is damaged or dirty. Switch RESUME , SHUFFLE or PROGRAM active. Press ▶II . Check and clean connections. Adjust the volume. Keep the player away from active mobile phones. Change the player's position or connections.

CAUTION

Use of controls or adjustments or performance of procedures other than herein may result in hazardous radiation exposure or other unsafe operation.

ACCESSORIES

ACCESSORIES FOR CD-PORTABLE		/00	/01/11	/10	/17
AY3170/00 AC/DC ADAPTOR	4822 219 10617	X			
AY3170/02 AC/DC ADAPTOR	4822 219 10449		X		
AY3170/10 AC/DC ADAPTOR	4822 219 10681			X	
AY3170/17 AC/DC ADAPTOR	4822 219 10616				X
HE545/77 HEADPHONE	9082 100 00268	X	X	X	X
INSTRUCTION MANUAL	3140 115 27990	X			
INSTRUCTION MANUAL	3140 115 28000	X	X	X	
INSTRUCTION MANUAL	3140 115 28010				X

SERVICE TOOLS

Audio signal disc SBC 429.....	4822 397 30184
Playability test disc SBC 444.....	4822 397 30245
Test disc 5 (disc without errors) +	
Test disc 5A (disc with dropout errors, black spots and fingerprints)	
SBC 426/426A.....	4822 397 30096
Burn in test disc (65 min. 1kHz signal at -30 dB level without "pause").....	4822 397 30155
Universal test cassette Fe SBC 420.....	4822 397 30071

ESD PROTECTION EQUIPMENT

anti-static table mat large 1200x650x1.25mm	4822 466 10953
small 600x650x1.25mm	4822 466 10958
anti-static wristband	4822 395 10223
connection box (3 press stud connections, 1M)	4822 320 11307
extendible cable (2m, 2M , to connect wristband to connection box)	4822 320 11305
connecting cable (3m, 2M , to connect table mat to connection box)	4822 320 11306
earth cable (1M , to connect any product to mat or to connection box)	4822 320 11308
KIT ESD3 (combining all 6 prior products - small table mat)	4822 310 10671
wristband tester	4822 344 13999

BLOCK DIAGRAM

3-1

3-1

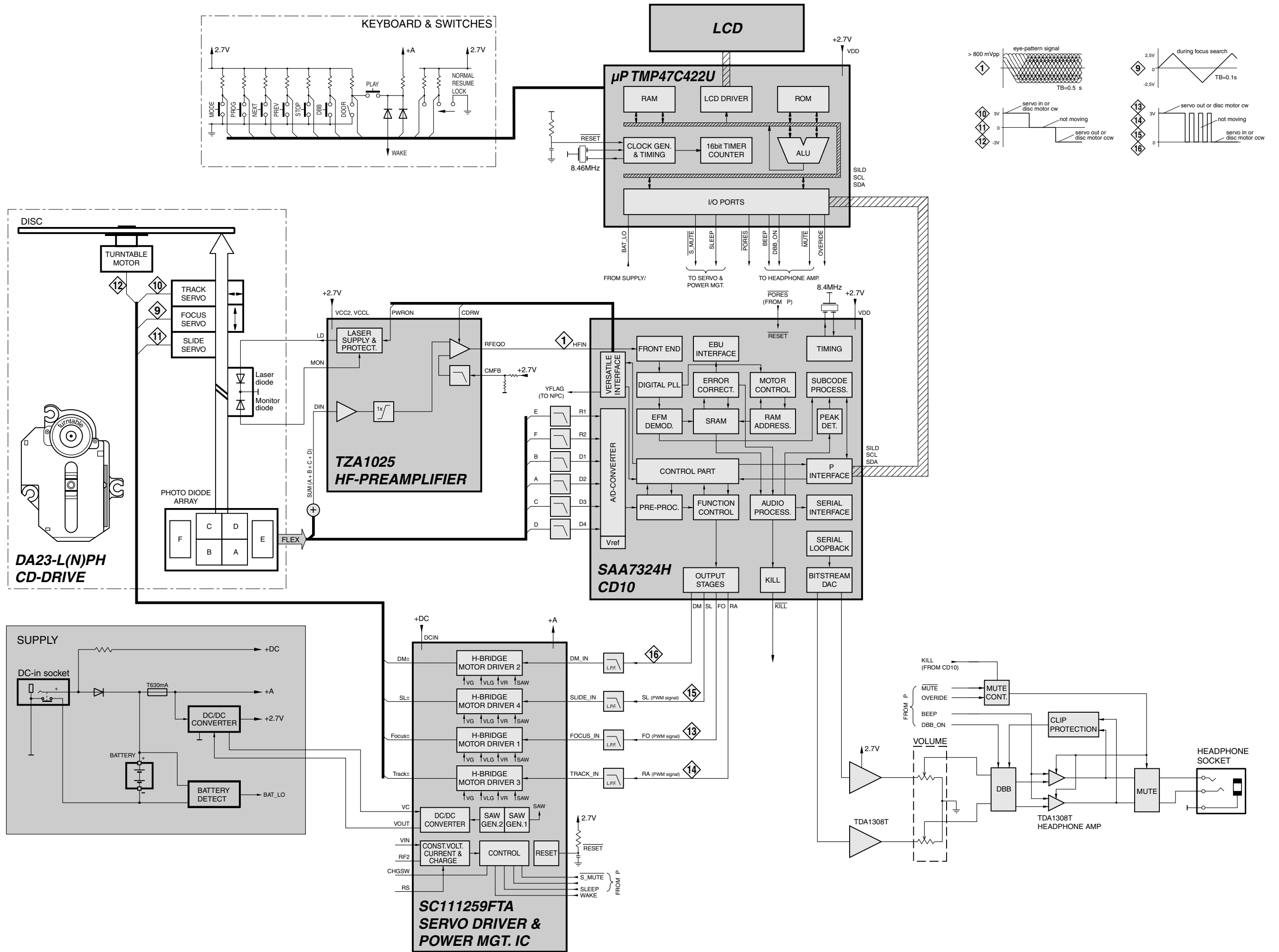

STARTUP PROCEDURE

3-2

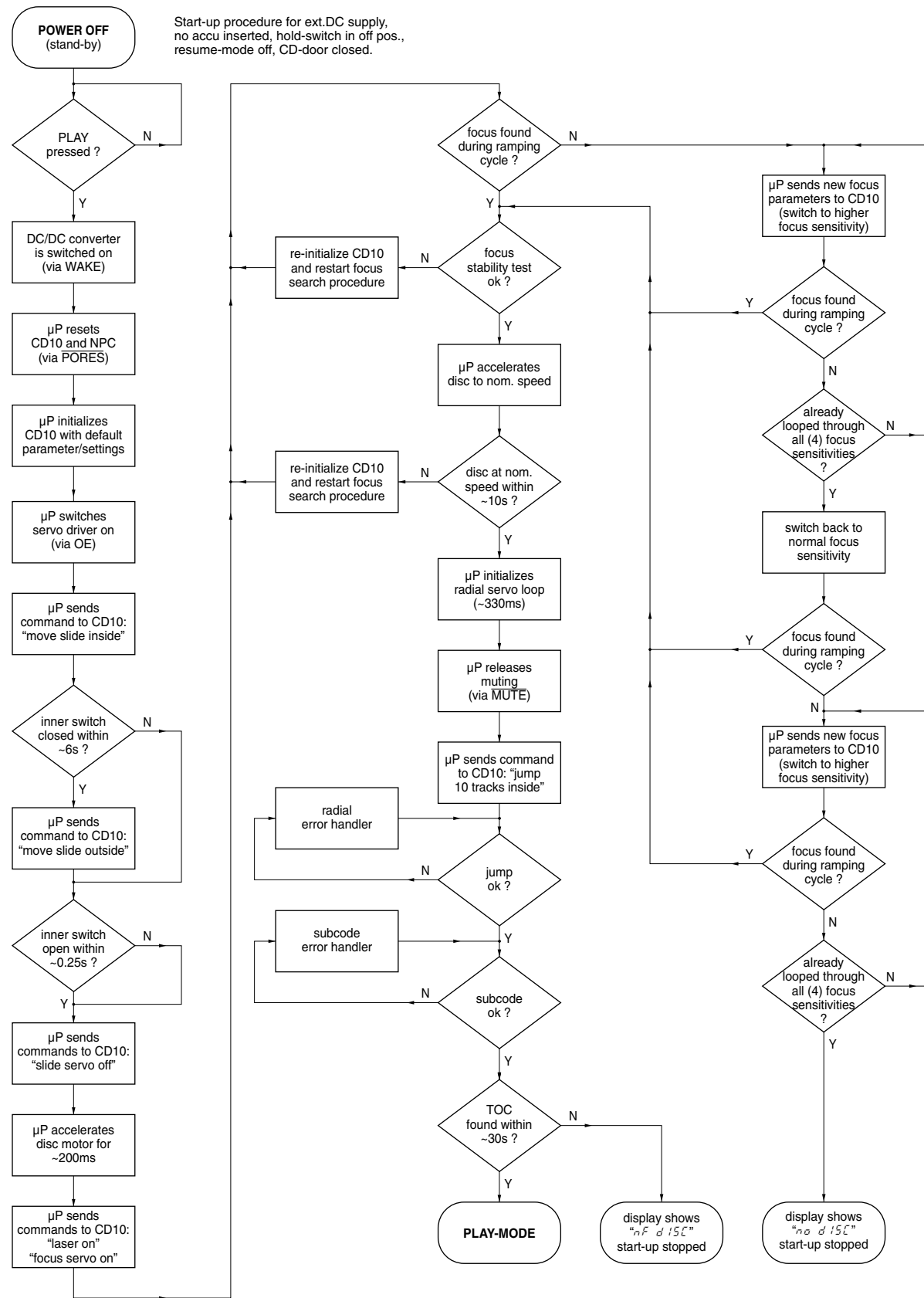

PINNING OF INTERGATED CIRCUITS

3-2

SAA7324 – DECODER, DIGITAL SERVO IC AND D/A-CONVERTER CD10 (low voltage version)

Pin	Name	Direction	Description
1	HFREF	CD10	comparator common mode input
2	HFIN	CD10	comparator signal input
3	ISLICE	CD10	current feedback from data slicer
4	VSSA1	GND	analog ground 1
5	VDDA1	+2.7	analog supply voltage 1
6	IREF	CD10	reference current output pin
7	VRIN	CD10	reference voltage for servo ADC's
8	D1	HF-preamp CD10	unipolar current input (central diode signal input)
9	D2	HF-preamp CD10	unipolar current input (central diode signal input)
10	D3	HF-preamp CD10	unipolar current input (central diode signal input)
11	D4	HF-preamp CD10	unipolar current input (central diode signal input)
12	R1	HF-preamp CD10	unipolar current input (satellite diode signal input)
13	R2	HF-preamp CD10	unipolar current input (satellite diode signal input)
14	VSSA2	GND	analog ground 2
15	CROUT	CD10 X-TAL	crystal/resonator output
16	CRIN	X-TAL CD10	crystal/resonator input
17	VDDA2	+2.7	analog supply voltage 2
18	LN	CD10	DAC left channel differential output - negative
19	LP	CD10	DAC left channel differential output - positive
20	VNEG	CD10	DAC negative reference input
21	VPOS	CD10	DAC positive reference input
22	RN	CD10	DAC right channel differential output - negative
23	RP	CD10	DAC right channel differential output - positive
24	SELPLL	+2.7	selects whether internal clock multiplier PLL is used
25	TEST1	GND	test control input 1; this pin should be tied low
26	CL16	CD10	16.9344 MHz system clock output
27	DATA	CD10 NPC	serial data output (3-state)
28	WCLK	CD10 NPC	word clock output (3-state)
29	SCLK	CD10 NPC	serial bit clock output (3-state)
30	EF	CD10	C2 error flag output (3-state)
31	TEST2	GND	test control input 2; this pin should be tied low
32	KILL	CD10 HF-preamp	kill output (programmable; open-drain)
33	VSSD1	GND	digital ground 2
34	V2/V3	CD10 NPC	versatile I/O: input versatile pin 2 or output versatile pin 3 (open-drain)
35	WCLI	NPC CD10	word clock input (for data loopback to DAC)
36	SDI	NPC CD10	serial data input (for data loopback to DAC)
37	SCLI	NPC CD10	serial bit clock input (for data loopback to DAC)
38	RESETn	μP CD10	power-on reset input (active low)
39	SDA	μP CD10	microcontroller interface data I/O line (open-drain output)
40	SCL	μP CD10	microcontroller interface clock line input
41	RAB	μP CD10	microcontroller interface R/W and load control line input (4-wire bus mode)
42	SILD	μP CD10	microcontroller interface R/W and load control line input (4-wire bus mode)
43	STATUS	CD10	servo interrupt request line/decoder status register output (open-drain)
44	TEST3	GND	test control input 3; this pin should be tied low
45	RCK	CD10	subcode clock input
46	SUB	CD10	P-to-W subcode bits output (3-state)
47	SFSY	CD10 μP	subcode frame sync output (3-state)
48	SBSY	CD10 NPC	subcode block sync output (3-state)
49	CL11/4	CD10	11.2896 MHz or 4.2336 MHz (for microcontroller) clock output
50	VSSD2	GND	digital ground 3
51	DOBM	CD10	bi-phase mark output (externally buffered; 3-state)
52	VDDD1P	+2.7	digital supply voltage 2 for periphery
53	CFLG	CD10	correction flag output (open-drain)
54	RA	CD10 servo driver	radial actuator output
55	FO	CD10 servo driver	focus actuator output
56	SL	CD10 servo driver	slide control output
57	VDDD2C	+2.7	digital supply voltage 3 for core
58	VSSD3	GND	digital ground 4
59	MOTO1	CD10 servo driver	motor output 1; versatile (3-state)
60	MOTO2	CD10	motor output 2; versatile (3-state)
61	V4	CD10 HF-EQ switch	versatile output pin 4
62	V5	CD10 HF-GAIN switch	versatile output pin 5
63	V1	innerswitch CD10	versatile input pin 1
64	LDON	CD10 HF-preamp	laser drive on output (open-drain)

4-1
CONTROL / SUPPLY PART - CIRCUIT DIAGRAM

4-1

U1 G3	1401 J14	1408 E12	2251 B4	2257 C10	2263 G10	2269 I5	2400 D15	3250 B9	3260 E8	3288 B9	3404 J12	3410 J15	3417 J18	3433 F18	3440 J15	3447 K18	6257 F11	7257 C19	F251 E2	F260 K7	F272 K13	F278 H19	F871 I15
U2 G3	1402 J14	1418 I18	2252 B8	2258 E7	2264 G10	2270 G11	2401 F18	3252 C7	3261 F10	3295 E8	3405 J12	3412 H18	3418 K19	3434 G18	3441 G4	5250 B7	7250 C9	7400 E14	F252 G3	F262 D7	F273 K13	F279 I19	F872 I15
1250 K5	1403 J14	1430 J15	2253 B8	2259 E9	2265 H5	2272 J6	2402 E18	3254 E5	3262 F10	3400 E19	3406 K12	3413 H18	3419 K18	3435 J16	3442 C19	5251 C10	7251 C8	7401-A J17	F253 D10	F263 C10	F274 K13	F867 L6	F873 I16
1251 A4	1404 K14	2240 B5	2254 C7	2260 E8	2266 H10	2273 J8	2405 I17	3255 F5	3268 G12	3401 F18	3407 K12	3414 D12	3420 J18	3436 E11	3444 D20	5400 F19	7253 F10	7401-B D19	F257 J5	F264 D11	F275 L13	F868 L6	F874 I17
1252 G2	1405 K14	2241 C11	2255 C9	2261 G1	2267 I5	2275 H11	2406 I18	3256 D9	3269 G11	3402 D17	3408 K12	3415 D12	3431 G18	3437 E11	3445 E20	6152 D10	7254 E10	9401 D10	F258 J6	F270 J13	F276 F12	F869 G10	F875 F18
1400 A13	1406 L14	2250 B5	2256 C9	2262 F5	2268 I10	2276 G4	2407 K18	3257 E7	3270 H11	3403 D17	3409 L12	3416 J15	3432 G18	3438 J17	3446 C18	6252 G3	7256 F9	F250 H1	F259 J7	F271 J13	F277 H18	F870 G5	F877 K18

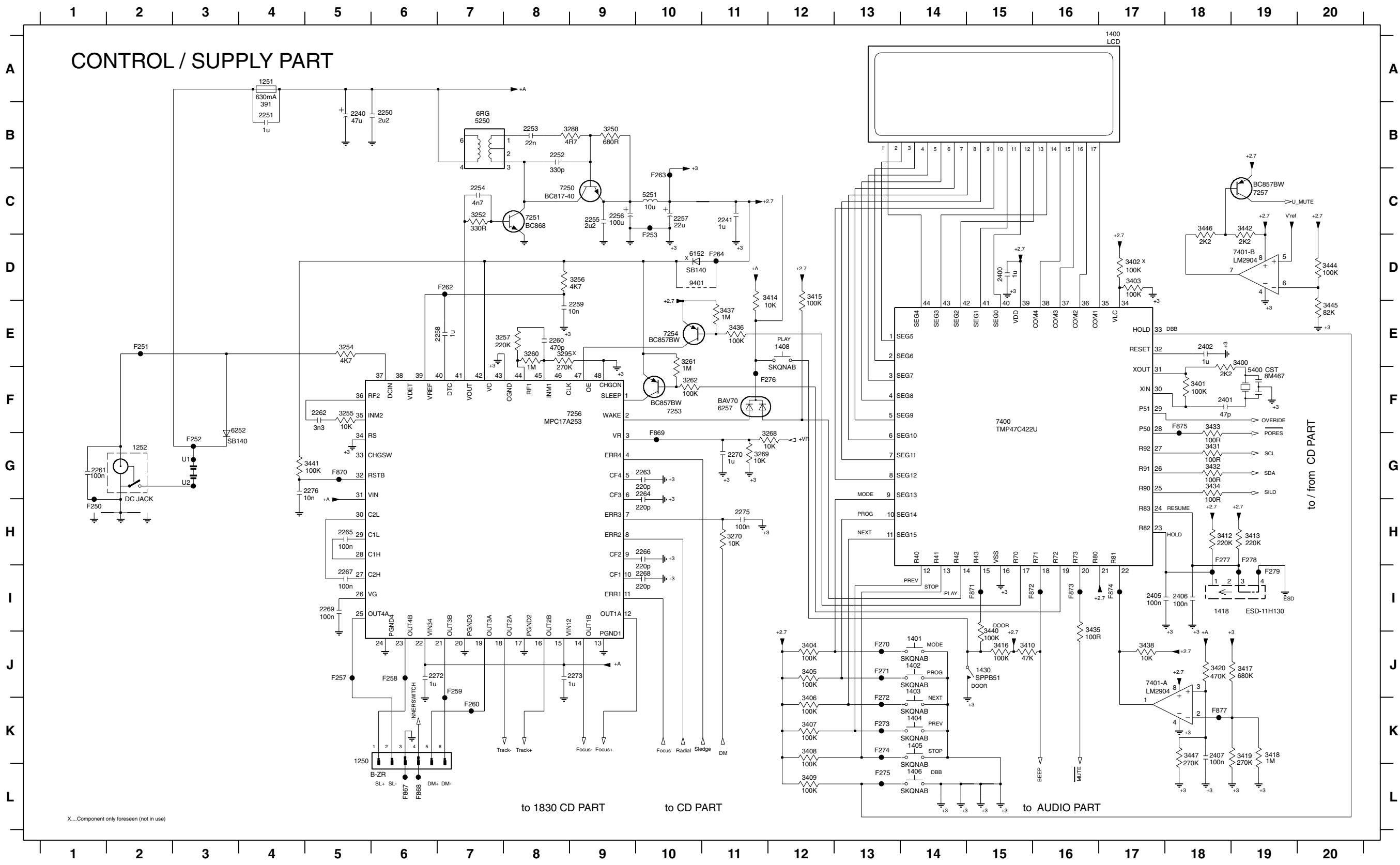

X...Component only foreseen (not in use)

AUDIO PART - CIRCUIT DIAGRAM

4-2

4-2

1300 C14	2306 E2	2320 F11	2333 G4	2343 G12	3314 E1	3324 E7	3338 E10	3344 F12	3350 E14	3366 G5	3373 D6	3379 D5	6300 B9	7301-A B11	7306 G10	F300 D14	F863 F9
2301 B2	2313 D7	2321 C12	2335 G3	2344 E12	3315 C2	3327 B7	3339 C10	3345 B12	3360 D8	3367 F2	3374 D6	3380 C11	6301 F9	7301-B E11	7309 C13	F301 B14	F864 D6
2302 D2	2314 D7	2322 F12	2339 G5	3300 D4	3316 E2	3328 E7	3340 F10	3346 E12	3361 E8	3368 G2	3375 C7	3381 F12	6302 C12	7302 D9	7310 E13	F302 E14	F865 G3
2303 C2	2315 C9	2325 D13	2340 E3	3311 B1	3317 B2	3333 D11	3341 C11	3347 C13	3362 E9	3370 C5	3376 D7	3382 D11	6303 C13	7303 C6	7311 D9	F860 D3	F866 F5
2304 E2	2316 F9	2326 D13	2341 C3	3312 E1	3318 D2	3334 E11	3342 F11	3348 E13	3364 F4	3371 C5	3377 B10	3383 D12	7300-A C3	7304 E6	7831 D5	F861 D3	
2305 C2	2319 C10	2332 D6	2342 E9	3313 C1	3323 B7	3337 B10	3343 C12	3349 B14	3365 F5	3372 D5	3378 F10	3384 D8	7300-B E3	7305 C11	F105 F4	F862 C9	

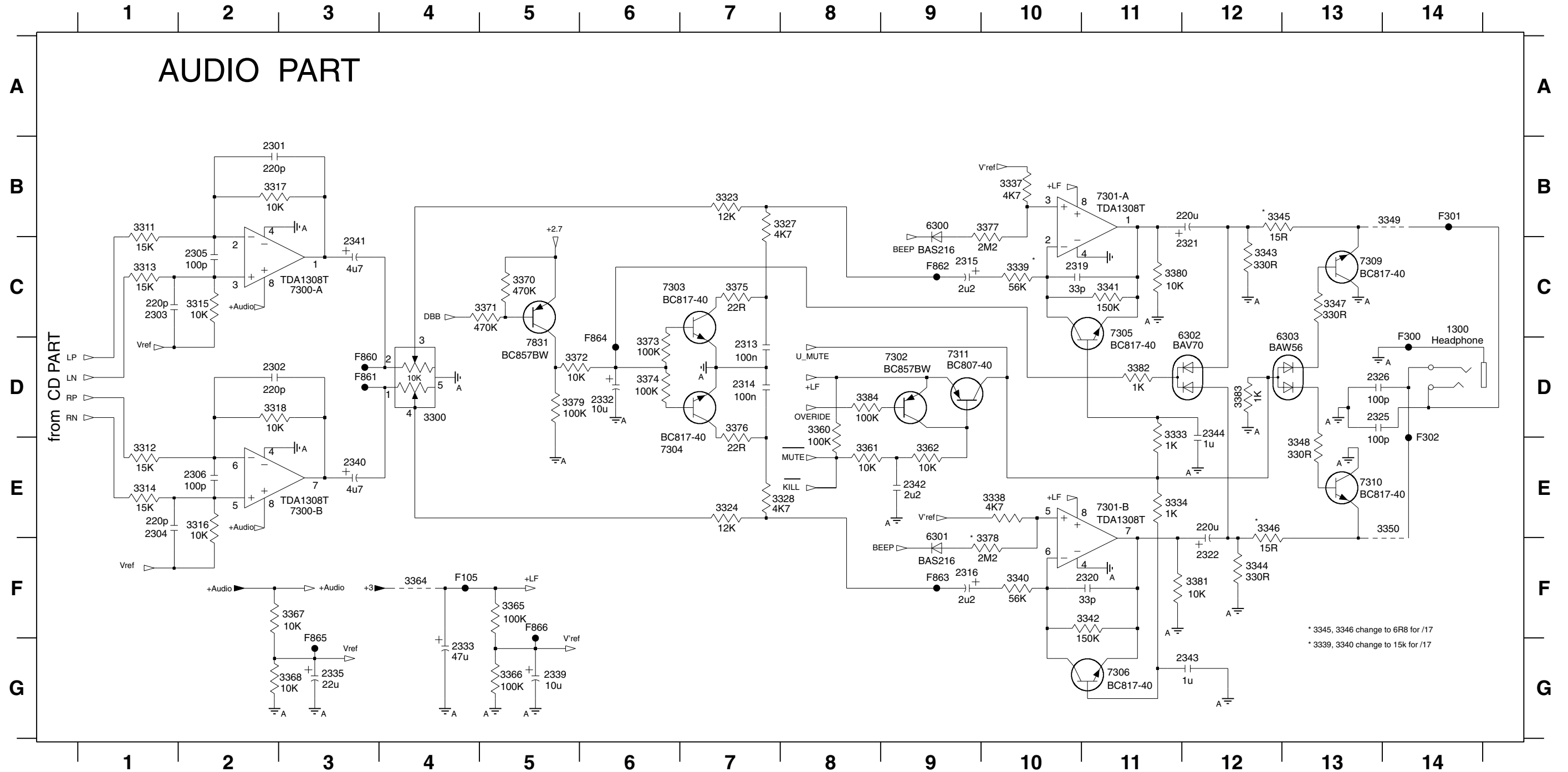

CD PART - CIRCUIT DIAGRAM

4-3

4-3

U10 D11	2802 C5	2830 F2	2834 H8	2838 H10	2842 H11	2846 D10	2850 C17	2854 C18	2858 I13	2862 C16	3802 E6	3806 E5	3830 F3	3834 F7	3838 G8	3842 G9	3846 H9	3850 E12	3854 B16	3858 B18	3862 F19	3868 I18	5800 I12	F830 E2	F834 F2	F838 G2	F842 G2	F846 D16	F859 A7	F882 G18
1830 E1	2803 E6	2831 H7	2835 H8	2839 H10	2843 F10	2847 D11	2851 C17	2855 C19	2859 J14	2888 I14	3803 C5	3807 E5	3831 F6	3835 H6	3839 G8	3843 G9	3847 E10	3851 D12	3855 B16	3859 B18	3863 F19	3869 J15	7800 C7	F831 E2	F835 F2	F839 G2	F843 H2	F847 J16	F878 C6	F884 J13
2800 C10	2804 E5	2832 H7	2836 H9	2840 H10	2844 F10	2848 D11	2852 C17	2856 H19	2860 I14	3800 C11	3804 C4	3808 A8	3832 F6	3836 H7	3840 F8	3844 G9	3848 F11	3852 C15	3856 B16	3860 F18	3866 I12	3870 C13	7801 A8	F832 E2	F836 F2	F840 G2	F844 E12	F857 D9	F879 D12	F885 J14
2801 D9	2805 E6	2833 H7	2837 H9	2841 H11	2845 F11	2849 E12	2853 C18	2857 J12	2861 D15	3801 D4	3805 C9	3809 A7	3833 F6	3837 G7	3841 F9	3845 H9	3849 D11	3853 C16	3857 B18	3861 F18	3867 I12	3874 E10	7830 D12	F833 E2	F837 F2	F841 G2	F845 J16	F858 A9	F880 E12	F886 J14

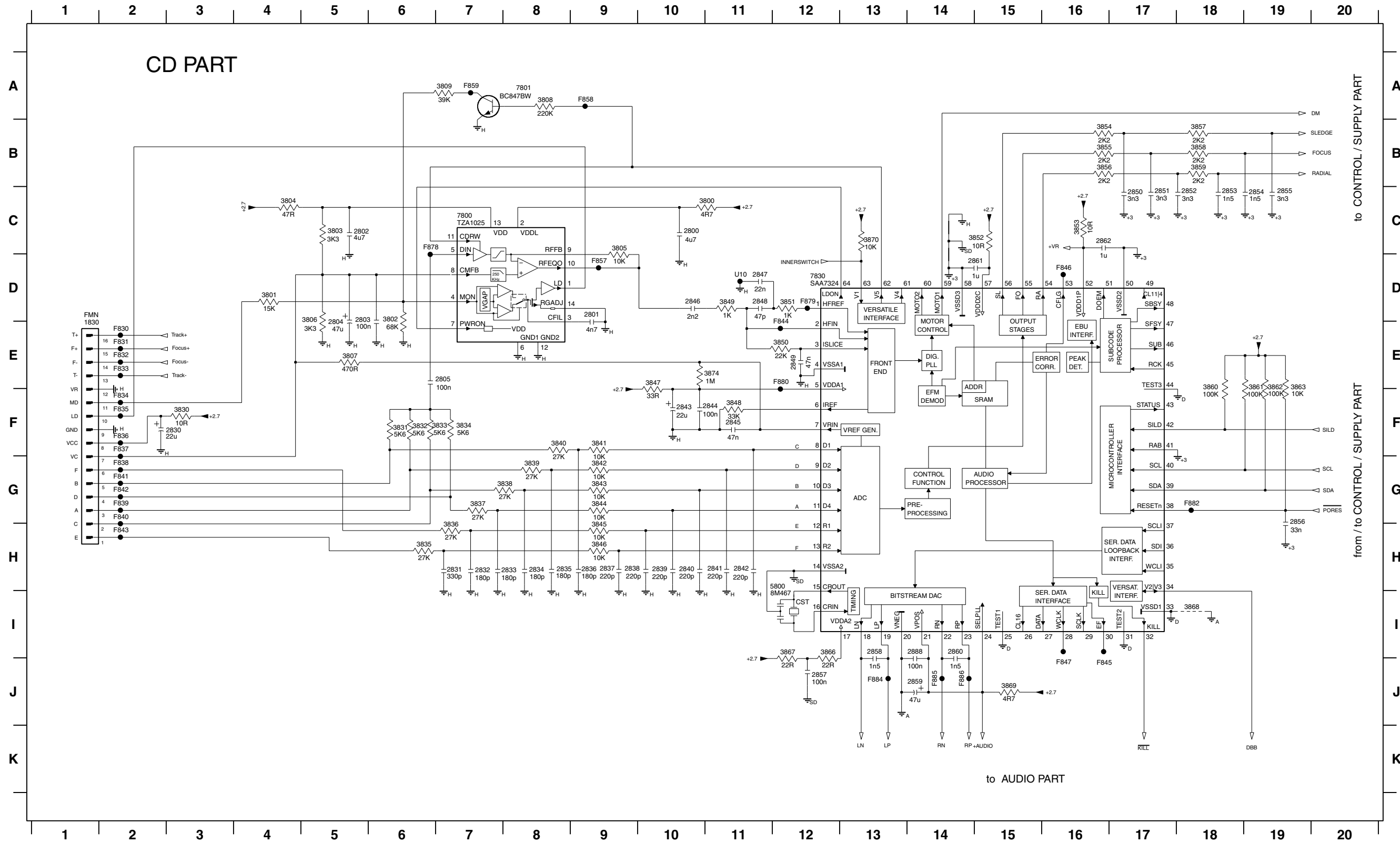

LAYOUT DIAGRAM (Component Side)

4-4

4-4

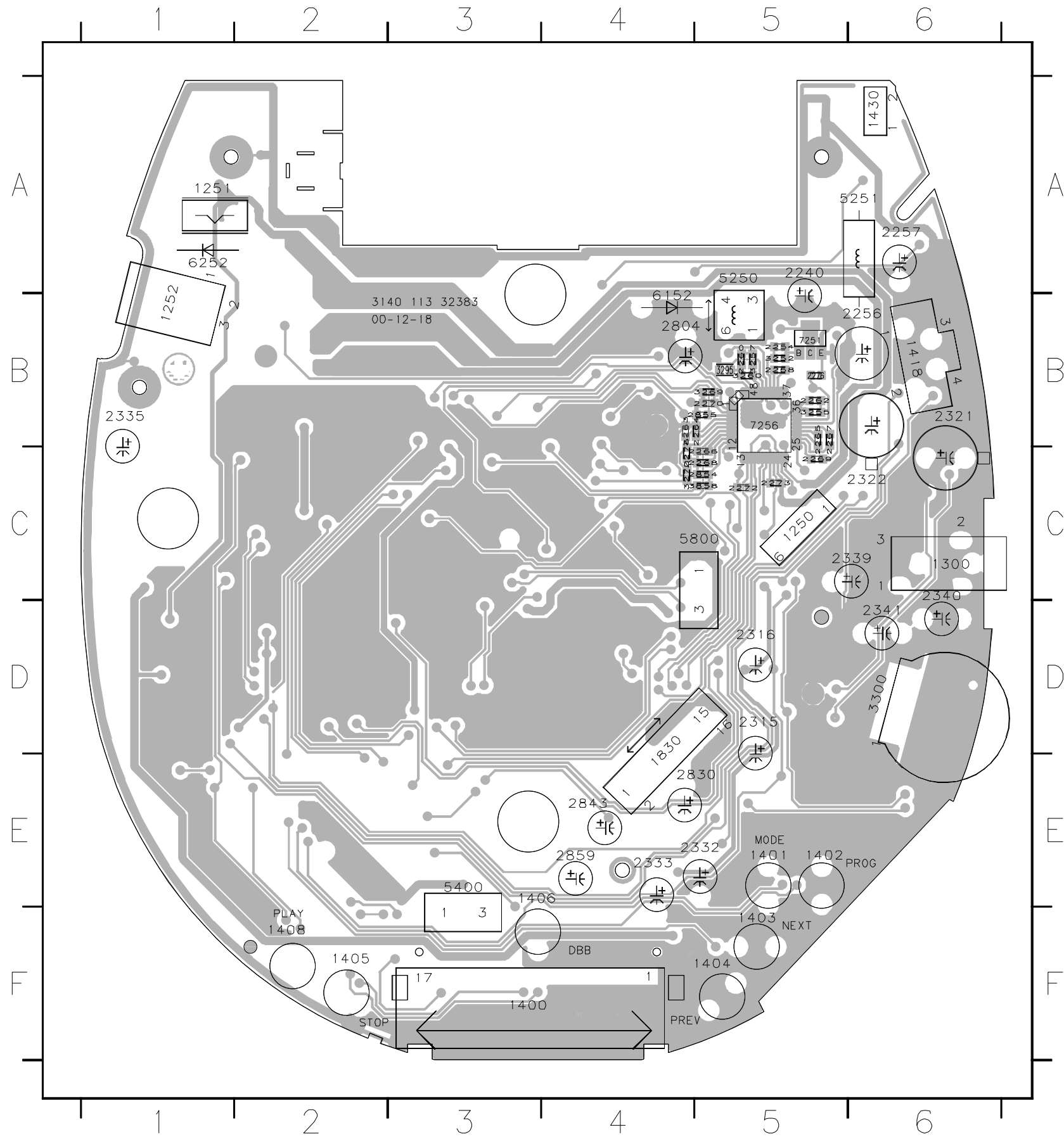

1250	C5	3270	C4
1251	A1	3295	B5
1252	B1	3300	D6
1300	C6	3858	C5
1400	F3	5250	A5
1401	E5	5251	A6
1402	E5	5400	E3
1403	F5	5800	C5
1404	F5	6152	B4
1405	F2	6252	A1
1406	E3	7251	B5
1408	F2	7256	B5
1418	B6		
1430	A6		
1830	D4		
2240	A5		
2254	B5		
2256	B6		
2257	A6		
2258	B5		
2260	B5		
2262	B5		
2263	B4		
2264	B5		
2265	B5		
2266	C5		
2267	B5		
2268	C5		
2269	C5		
2270	B5		
2272	C5		
2273	C5		
2275	C4		
2276	B5		
2315	D5		
2316	D5		
2321	B6		
2322	C6		
2332	E5		
2333	E4		
2335	B1		
2339	C6		
2340	C6		
2341	D6		
2804	B4		
2830	E5		
2843	E4		
2854	C5		
2855	B5		
2859	E4		
3252	B5		
3255	B5		
3257	B5		
3260	B5		
3269	B5		

EXPLODED VIEW DIAGRAM

5-1

SCREW LIST

- 1. C 1.4 x 5
- 2. C1.6 x 9

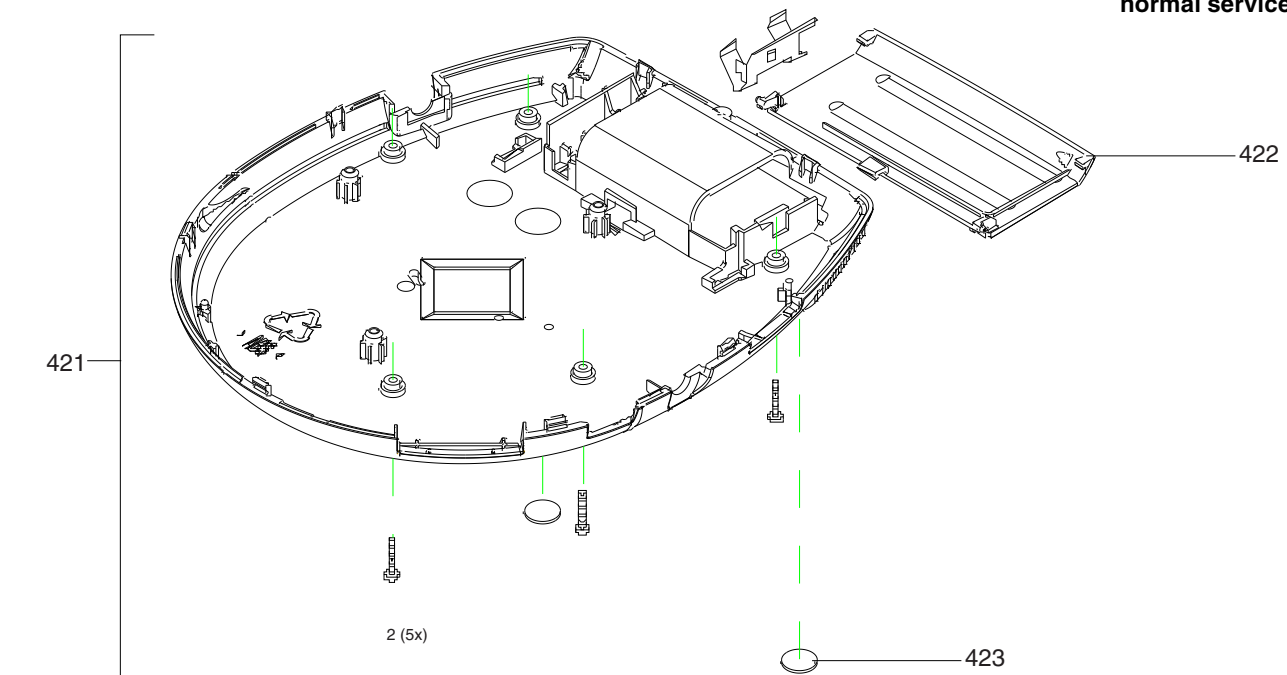
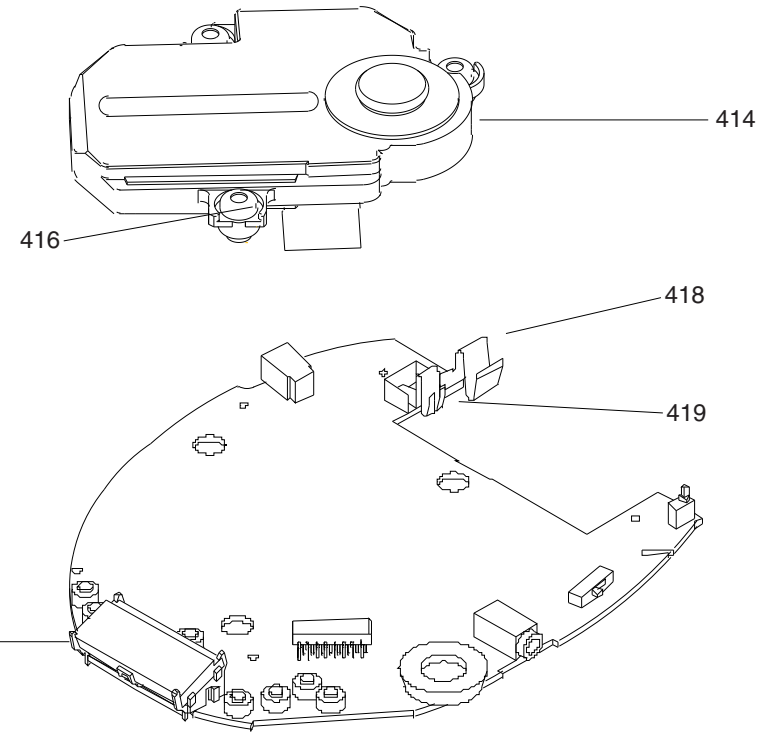
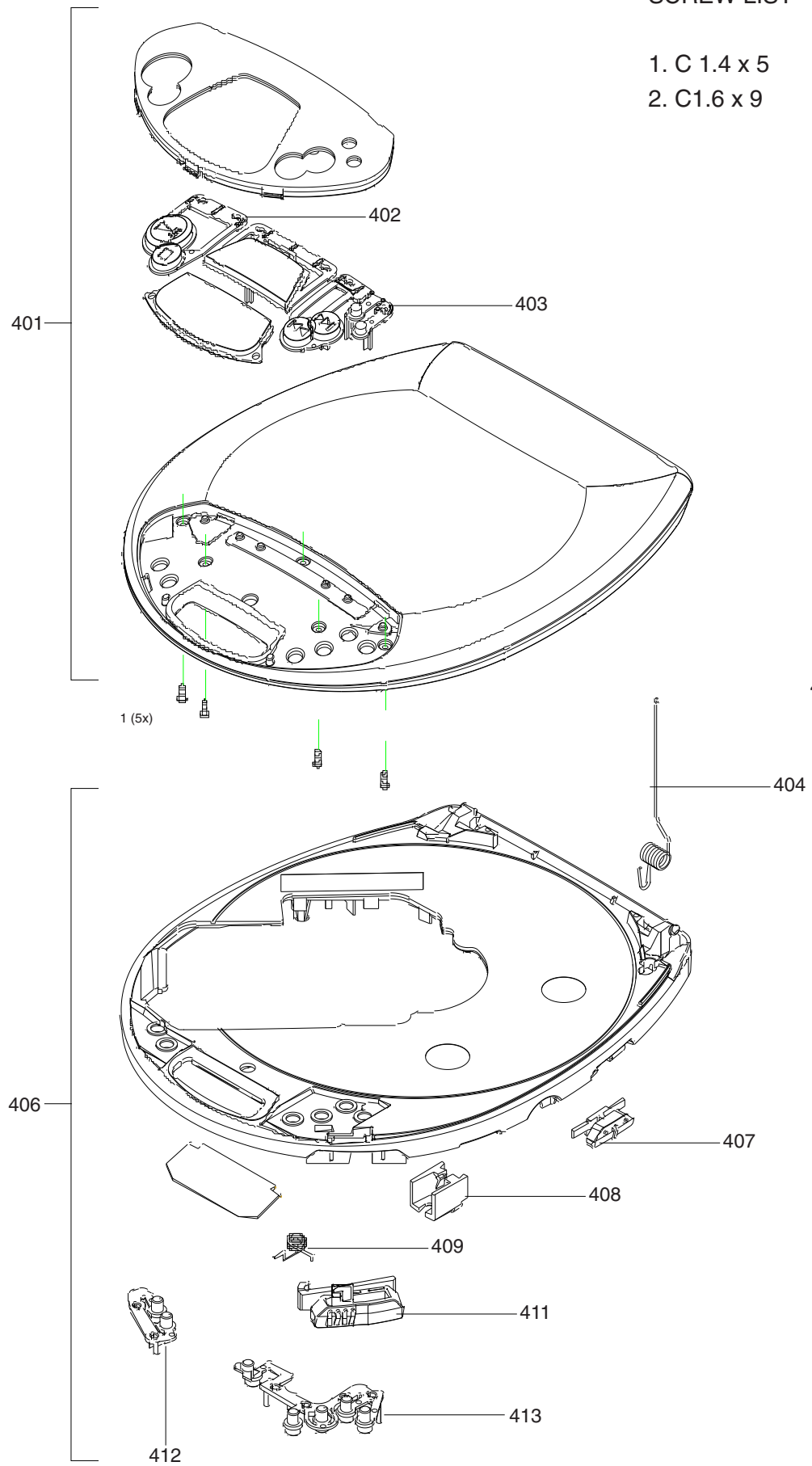

5-1

MECHANICAL PARTSLIST

- 401 3140 117 60210 Door-CD-Basic-Assy-1
- 402 3140 117 60252 Button-Set-Play/Stop
- 403 3140 117 60262 Button-Set-Prev/Next
- 404 3140 111 00820 Spring-Open-R
- 406 3140 117 60220 Cabinet-Assy-1

- 407 3140 114 35771 Slider Resume
- 408 3140 114 36181 Brake
- 409 3103 301 06501 Spring-Slider-Open 2
- 411 3140 115 35781 Slider-open
- 412 3140 114 35801 Adaptor-Button-Set-Play/Stop

- 413 3140 114 35811 Adaptor-Button-Set-Prev/Next
- 414 3103 309 05321 CD DA23LN Drive Assy
- 416 3103 304 69590 Suspension
- 417 3140 114 35840 Bracket-LCD
- 418 3140 111 21520 Spring-Battery-Plus

- 419 3140 111 21530 Spring-Battery-Minus
- 421 3140 117 60910 Bottom-Assy-2 (For AX1000)
- 421 3140 117 60230 Bottom-Assy-2 (For AX1001)
- 422 3140 114 35830 Battery Door
- 423 3103 304 41232 Rubber Foot

- 9082 100 00268 Headphone HE545/77
- 4822 219 10617 Adaptor AY3170/00 (For -/00)
- 4822 219 10449 Adaptor AY3160/02 (For -/01/11)
- 4822 219 10681 Adaptor AY3170/10 (For -/10)
- 4822 219 10616 Adaptor AY3170/17 (For -/17)

Note: Only these parts mentioned in the list are normal service parts.

CD DRIVE ASSEMBLY

From production start to week 0108.

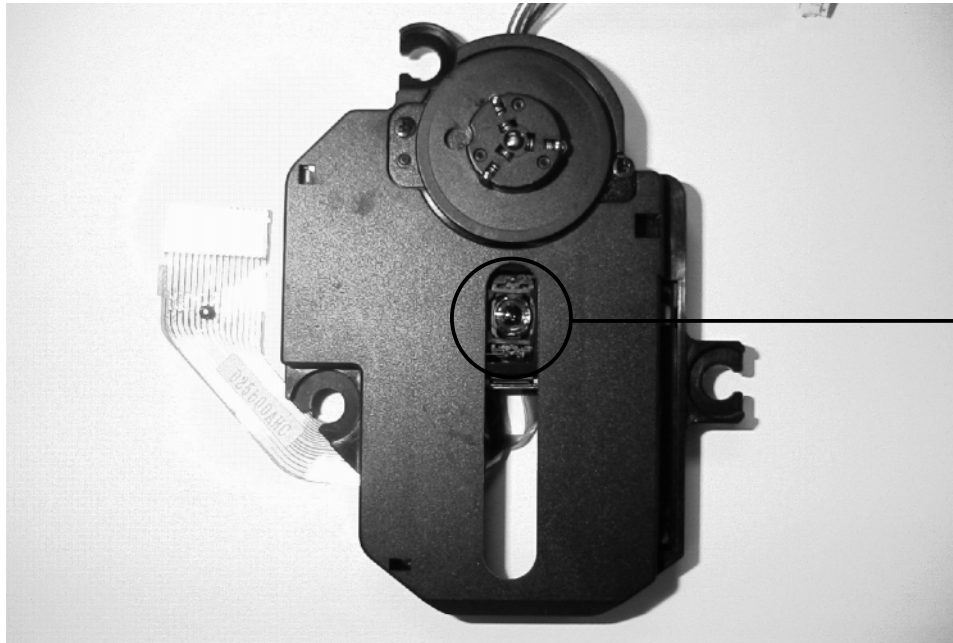

black in colour

414 CD Drive DA23L (3103 309 05341)
 7400 MCU TMP47C422 -U-AX1000L-1 (3140 1 10 50981)

From production week 0109 onwards.

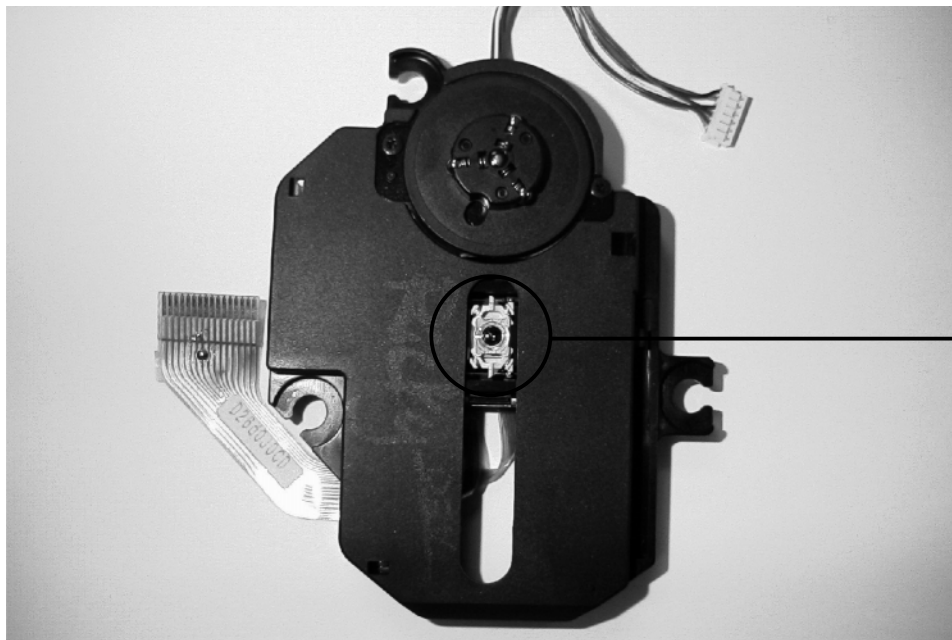

white in colour

414 CD Drive DA23LN (3103 309 05321)
 7400 MCU TMP47C422 -U-AX1000LN-1 (3140 1 10 51120)

ELECTRICAL PARTSLIST**- CAPACITORS -**

2240	4822 124 80483	47µF 20% 6,3V
2241	3198 017 41050	1µF Y5V 10V
2250	4822 126 14491	2.2µF 10V
2251	3198 017 41050	1µF Y5V 10V
2252	4822 126 14241	330pF NPO 50V
2253	4822 126 14494	22nF 10% X7R 25V
2254	4822 126 13193	4,7nF 10% X7R 63V
2255	4822 126 14491	2.2µF 10V 0805
2256	4822 124 23432	100µF 20% 10V
2257	4822 124 40998	22µF 20% 6,3V
2258	3198 017 41050	1µF Y5V 10V
2259	5322 126 11583	10nF 10% X7R 50V
2260	4822 126 13881	470pF 5% 50V
2261	4822 126 14305	100nF 10% X7R 16V
2262	5322 126 11579	3,3nF 10% X7R 63V
2263	4822 126 13883	220pF 5% 50V
2264	4822 126 13883	220pF 5% 50V
2265	4822 126 14305	100nF 10% X7R 16V
2266	4822 126 13883	220pF 5% 50V
2267	4822 126 14305	100nF 10% X7R 16V
2268	4822 126 13883	220pF 5% 50V
2269	4822 126 14305	100nF 10% X7R 16V
2270	3198 017 41050	1µF Y5V 10V
2272	3198 017 41050	1µF Y5V 10V
2273	3198 017 41050	1µF Y5V 10V
2275	4822 126 14305	100nF 10% X7R 16V
2276	5322 126 11583	10nF 10% X7R 50V
2301	4822 126 13883	220pF 5% 50V
2302	4822 126 13883	220pF 5% 50V
2303	4822 126 13883	220pF 5% 50V
2304	4822 126 13883	220pF 5% 50V
2305	4822 122 31765	100pF 2% NP0 63V
2306	4822 122 31765	100pF 2% NP0 63V
2313	4822 126 14305	100nF 10% X7R 16V
2314	4822 126 14305	100nF 10% X7R 16V
2315	4822 124 22652	2,2µF 20% 50V
2316	4822 124 22652	2,2µF 20% 50V
2319	4822 126 11671	33pF
2320	4822 126 11671	33pF
2321	4822 124 12245	220µF 20% 10V
2322	4822 124 12245	220µF 20% 10V
2325	4822 122 31765	100pF 2% NP0 63V
2326	4822 122 31765	100pF 2% NP0 63V
2327	5322 126 11583	10nF 10% X7R 50V
2332	4822 124 11947	10µF 20% 16V
2333	4822 124 80483	47µF 20% 6,3V
2335	4822 124 40998	22µF 20% 6,3V
2339	4822 124 11947	10µF 20% 16V
2340	4822 124 22726	4,7µF 35V
2341	4822 124 22726	4,7µF 35V

- CAPACITORS -

2342	4822 126 14491	2.2µF 10V
2343	3198 017 41050	1µF Y5V 10V
2344	3198 017 41050	1µF Y5V 10V
2400	3198 017 41050	1µF Y5V 10V
2401	4822 122 33777	47pF 5% NP0 63V
2402	3198 017 41050	1µF Y5V 10V
2405	4822 126 14305	100nF 10% X7R 16V
2406	4822 126 14305	100nF 10% X7R 16V
2407	4822 126 14305	100nF 10% X7R 16V
2800	2020 552 96305	4,7µF +80-20% Y5V 10V
2801	4822 126 13193	4,7nF 10% X7R 63V
2802	2020 552 96305	4,7µF +80-20% Y5V 10V
2803	4822 126 14305	100nF 10% X7R 16V
2804	4822 124 80483	47µF 20% 6,3V
2805	4822 126 14305	100nF 10% X7R 16V
2830	4822 124 40998	22µF 20% 6,3V
2831	4822 126 14241	330pF NPO 50V
2832	4822 126 14508	180pF 5% 50V
2833	4822 126 14508	180pF 5% 50V
2834	4822 126 14508	180pF 5% 50V
2835	4822 126 14508	180pF 5% 50V
2836	4822 126 14508	180pF 5% 50V
2837	4822 126 13883	220pF 5% 50V
2838	4822 126 13883	220pF 5% 50V
2839	4822 126 13883	220pF 5% 50V
2840	4822 126 13883	220pF 5% 50V
2841	4822 126 13883	220pF 5% 50V
2842	4822 126 13883	220pF 5% 50V
2843	4822 124 40998	22µF 20% 6,3V
2844	4822 126 14305	100nF 10% X7R 16V
2845	3198 017 34730	47nF X7R 16V
2846	4822 126 14238	2,2nF X7R 50V
2847	4822 126 14494	22nF 10% X7R 25V
2848	4822 122 33777	47pF 5% NP0 63V
2849	3198 017 34730	47nF X7R 16V
2850	5322 126 11579	3,3nF 10% X7R 63V
2851	5322 126 11579	3,3nF 10% X7R 63V
2852	5322 126 11579	3,3nF 10% X7R 63V
2853	4822 126 14247	1,5nF X7R 50V
2854	4822 126 14247	1,5nF X7R 50V
2855	5322 126 11579	3,3nF 10% X7R 63V
2856	4822 126 14549	33nF 16V X7R
2857	4822 126 14305	100nF 10% X7R 16V
2858	4822 126 13344	1,5nF 5% 63V
2859	4822 124 80483	47µF 20% 6,3V
2860	4822 126 13344	1,5nF 5% 63V
2861	3198 017 41050	1µF Y5V 10V
2862	3198 017 41050	1µF Y5V 10V
2888	4822 126 14305	100nF 10% X7R 16V

ELECTRICAL PARTSLIST**- RESISTORS -**

3250	4822 051 30681	680R	5%	0,062W
3252	4822 051 30331	330R	5%	0,062W
3254	4822 051 30472	4K7	5%	0,062W
3255	4822 051 30103	10K	5%	0,062W
3256	3198 021 31520	1K5	5%	0,062W
3257	4822 117 12891	220K	1%	
3260	4822 051 30105	1M	5%	0,062W
3261	4822 051 30105	1M	5%	0,062W
3262	4822 117 13632	100K	1%	0,62W
3268	4822 051 30103	10K	5%	0,062W
3269	4822 051 30103	10K	5%	0,062W
3270	4822 051 30103	10K	5%	0,062W
3288	4822 117 13608	4,7R	5%	0,0016W
3300	3103 308 53680	Var Resistor		10K
3311	4822 051 30153	15K	5%	0,062W
3312	4822 051 30153	15K	5%	0,062W
3313	4822 051 30153	15K	5%	0,062W
3314	4822 051 30153	15K	5%	0,062W
3315	4822 051 30103	10K	5%	0,062W
3316	4822 051 30103	10K	5%	0,062W
3317	4822 051 30103	10K	5%	0,062W
3318	4822 051 30103	10K	5%	0,062W
3323	4822 051 30123	12K	5%	0,062W
3324	4822 051 30123	12K	5%	0,062W
3327	4822 051 30472	4K7	5%	0,062W
3328	4822 051 30472	4K7	5%	0,062W
3333	4822 051 30102	1K	5%	0,062W
3334	4822 051 30102	1K	5%	0,062W
3337	4822 051 30472	4K7	5%	0,062W
3338	4822 051 30472	4K7	5%	0,062W
3339	4822 051 30563	56K	5%	0,062W
3340	4822 051 30563	56K	5%	0,062W
3343	4822 051 30331	330R	5%	0,062W
3344	4822 051 30331	330R	5%	0,062W
3345	4822 117 13608	4,7R	5%	0,0016W
3346	4822 117 13608	4,7R	5%	0,0016W
3347	4822 051 30331	330R	5%	0,062W
3348	4822 051 30331	330R	5%	0,062W
3349	4822 117 13613	2R2	5%	
3350	4822 117 13613	2R2	5%	
3360	4822 117 13632	100K	1%	0,62W
3361	4822 051 30103	10K	5%	0,062W
3362	4822 051 30103	10K	5%	0,062W
3364	4822 051 30008	Jumper		
3365	4822 117 13632	100K	1%	0,62W
3366	4822 117 13632	100K	1%	0,62W
3367	4822 051 30103	10K	5%	0,062W
3368	4822 051 30103	10K	5%	0,062W
3370	4822 051 30474	470K	5%	0,062W
3371	4822 051 30474	470K	5%	0,062W

- RESISTORS -

3372	4822 051 30103	10K	5%	0,062W
3373	4822 117 13632	100K	1%	0,62W
3374	4822 117 13632	100K	1%	0,62W
3375	4822 117 12139	22R	5%	0,062W
3376	4822 117 12139	22R	5%	0,062W
3377	3198 021 32250	2M2	5%	
3378	3198 021 32250	2M2	5%	
3379	4822 117 13632	100K	1%	0,62W
3382	4822 051 30102	1K	5%	0,062W
3383	4822 051 30102	1K	5%	0,062W
3384	4822 117 13632	100K	1%	0,62W
3400	4822 051 30222	2K2	5%	0,062W
3401	4822 117 13632	100K	1%	0,62W
3403	4822 117 13632	100K	1%	0,62W
3404	4822 117 13632	100K	1%	0,62W
3405	4822 117 13632	100K	1%	0,62W
3406	4822 117 13632	100K	1%	0,62W
3407	4822 117 13632	100K	1%	0,62W
3408	4822 117 13632	100K	1%	0,62W
3409	4822 117 13632	100K	1%	0,62W
3410	4822 117 12925	47K	1%	0,063W
3412	4822 117 12891	220K	1%	
3413	4822 117 12891	220K	1%	
3414	4822 051 30103	10K	5%	0,062W
3415	4822 117 13632	100K	1%	0,62W
3416	4822 117 13632	100K	1%	0,62W
3417	5322 117 13039	220K	1%	0,063W
3418	4822 051 30684	680K	5%	0,062W
3419	2322 704 62704	270K	1%	
3420	4822 117 13632	100K	1%	0,62W
3421	4822 051 30008	Jumper		
3431	4822 051 30101	100R	5%	0,062W
3432	4822 051 30101	100R	5%	0,062W
3433	4822 051 30101	100R	5%	0,062W
3434	4822 051 30101	100R	5%	0,062W
3435	4822 051 30101	100R	5%	0,062W
3436	4822 117 13632	100K	1%	0,62W
3437	4822 051 30105	1M	5%	0,062W
3438	4822 051 30103	10K	5%	0,062W
3440	4822 117 13632	100K	1%	0,62W
3441	4822 117 13632	100K	1%	0,62W
3442	4822 051 30222	2K2	5%	0,062W
3444	4822 117 13632	100K	1%	0,62W
3445	4822 117 12864	82K	5%	0,6W
3446	4822 051 30222	2K2	5%	0,062W
3800	4822 117 13608	4,7R	5%	0,0016W
3801	4822 051 30153	15K	5%	0,062W
3802	4822 051 30683	68K	5%	0,062W
3803	4822 051 30332	3K3	5%	0,062W
3804	4822 051 30479	47R	5%	0,062W

ELECTRICAL PARTSLIST**- RESISTORS -**

3805	4822 051 30103	10K	5%	0,062W
3806	4822 051 30332	3K3	5%	0,062W
3807	4822 051 30471	470R	5%	0,062W
3808	4822 117 12891	220K	1%	
3809	4822 051 30393	39K	5%	0,062W
3830	4822 051 30109	10R	5%	0,062W
3831	4822 051 30562	5K6	5%	0,063W
3832	4822 051 30562	5K6	5%	0,063W
3833	4822 051 30562	5K6	5%	0,063W
3834	4822 051 30562	5K6	5%	0,063W
3835	4822 051 30273	27K	5%	0,062W
3836	4822 051 30273	27K	5%	0,062W
3837	4822 051 30273	27K	5%	0,062W
3838	4822 051 30273	27K	5%	0,062W
3839	4822 051 30273	27K	5%	0,062W
3840	4822 051 30273	27K	5%	0,062W
3841	4822 051 30103	10K	5%	0,062W
3842	4822 051 30103	10K	5%	0,062W
3843	4822 051 30103	10K	5%	0,062W
3844	4822 051 30103	10K	5%	0,062W
3845	4822 051 30103	10K	5%	0,062W
3846	4822 051 30103	10K	5%	0,062W
3847	4822 051 30339	33R	5%	0,062W
3848	4822 051 30333	33K	5%	0,062W
3849	4822 051 30102	1K	5%	0,062W
3850	4822 051 30223	22K00	5%	0,062W
3851	4822 051 30102	1K	5%	0,062W
3852	4822 051 30109	10R	5%	0,062W
3853	4822 051 30109	10R	5%	0,062W
3854	4822 051 30222	2K2	5%	0,062W
3855	4822 051 30222	2K2	5%	0,062W
3856	4822 051 30222	2K2	5%	0,062W
3857	4822 051 30222	2K2	5%	0,062W
3858	4822 051 30222	2K2	5%	0,062W
3859	4822 051 30222	2K2	5%	0,062W
3860	4822 117 13632	100K	1%	0,62W
3861	4822 117 13632	100K	1%	0,62W
3862	4822 117 13632	100K	1%	0,62W
3863	4822 051 30103	10K	5%	0,062W
3866	4822 117 12139	22R	5%	0,062W
3867	4822 117 12139	22R	5%	0,062W
3869	4822 117 13608	4,7R	5%	0,0016W
3870	4822 051 30103	10K	5%	0,062W
3874	4822 051 30105	1M	5%	0,062W

- COIL & FILTERS -

5251	4822 157 51462	Coil 10μH	10%	
5400	8240 005 52990	Filter 8,467MHz		
5800	8240 005 52990	Filter 8,467MHz		

- DIODES -

6252	5322 130 81917	Diode SB140		
6257	5322 130 34331	Diode BAV70		
6300	4822 130 83757	Diode BAS216		
6301	4822 130 83757	Diode BAS216		
6302	5322 130 34331	Diode BAV70		
6303	5322 130 30691	Diode BAW56		

- IC & TRANSISTORS -

7250	4822 130 42615	Trans BC817-40		
7251	5322 130 61569	Trans BC868		
7253	5322 130 42756	Trans BC857C		
7254	5322 130 42756	Trans BC857C		
7256	9322 160 31669	IC SC111259FTA		
7256	8203 303 85110	IC SC111259		
7257	5322 130 42756	Trans BC857C		
7300	4822 209 33165	IC TDA1308T/N1		
7301	4822 209 33165	IC TDA1308T/N1		
7302	5322 130 42756	Trans BC857C		
7303	4822 130 42615	Trans BC817-40		
7304	4822 130 42615	Trans BC817-40		
7305	4822 130 42615	Trans BC817-40		
7306	4822 130 42615	Trans BC817-40		
7309	4822 130 42615	Trans BC817-40		
7310	4822 130 42615	Trans BC817-40		
7311	5322 130 60123	Trans BC807-40		
7400	3140 110 50980	IC MCU TMP47C422U		
7401	5322 209 12343	IC LM2904D		
7800	9352 622 36118	IC SM TZA1025T/V2		
7801	3198 010 42310	Trans BC847BW		
7830	9352 641 80557	IC SAA7324H/M2B		
7830	9352 642 17557	IC SAA7325H/M2B		

- MISCELLANEOUS -

1250	2422 025 12272	Connector 6P		
1251	△ 2422 086 10946	Fuse 0.63A 65V		
1252	2422 026 05086	DC Socket		
1300	2422 026 05203	Headphone Socket		
1400	3140 110 50950	LCD Panel		
1401	2422 128 02917	Tact Switch		
1402	2422 128 02917	Tact Switch		
1403	2422 128 02917	Tact Switch		
1404	2422 128 02917	Tact Switch		
1405	2422 128 02917	Tact Switch		
1406	2422 128 02917	Tact Switch		
1408	2422 128 02917	Tact Switch		
1418	4822 277 21643	Slide Switch		
1430	4822 276 12889	Push Switch		
1830	4822 267 11028	Connector 16P		