

Service
Service
Service



Service Manual



TABLE OF CONTENTS

Handling Chip Components and Safety1 - 1

Technical Specification & Service tools2 - 1

Service Measurement.....2 - 2

Connections and controls3 - 1

Instruction for use.....3-2 - 3-4

Disassembly Diagram.....4 - 1

Block Diagram5 - 1

Wiring Diagram5 - 2

Tuner Board

 Circuit diagram6 - 1

 Tuner adjustment6 - 1

 Layout diagram.....6 - 2

Recorder Board

 Circuit diagram7 - 1

 Layout diagram.....7 - 2

 Tape deck adjustment7 - 2

CD / Control Board

 Circuit diagram8 - 1

 Layout diagram.....8 - 2

Power Board

 Circuit diagram9 - 1

 Layout diagram.....9 - 2

Rectifier Board

 Circuit diagram9 - 2

 Layout diagram.....9 - 2

Exploded view - cabinet.....10 - 1

Mechanical partslist10 - 2

Electrical partslist11 - 1 .. 11 - 2



© Copyright 2001 Philips Consumer Electronics B.V. Eindhoven, The Netherlands
 All rights reserved. No part of this publication may be reproduced, stored in a retrieval system or transmitted, in any form or by any means, electronic, mechanical, photocopying, or otherwise without the prior permission of Philips.

Published by YT 0317 Service Audio Printed in The Netherlands Subject to modification

GB 3140 785 32630

Version 1.0



PHILIPS

HANDLING CHIP COMPONENTS

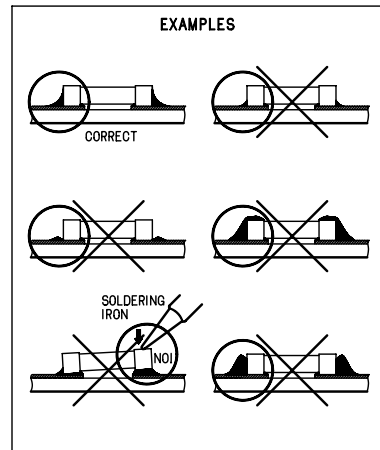
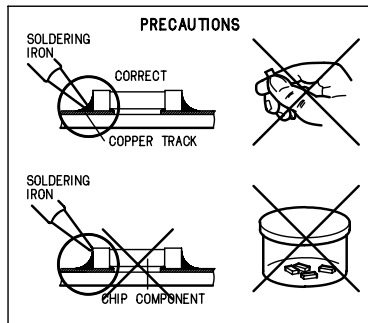
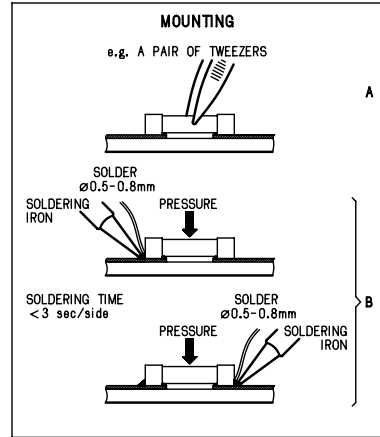
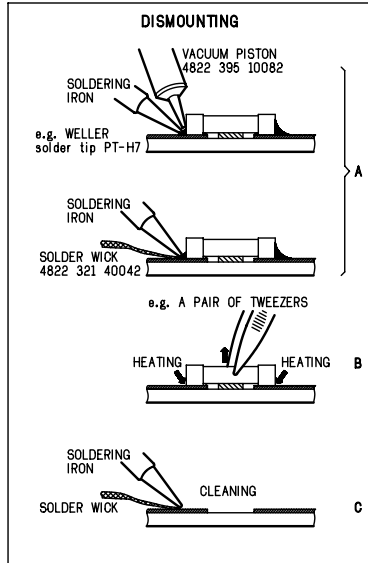
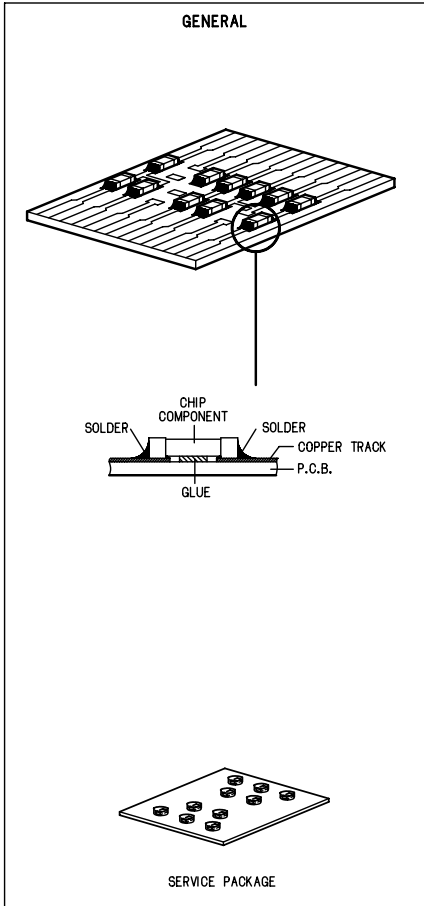

(GB) WARNING

All ICs and many other semiconductors are susceptible to electrostatic discharges (ESD). Careless handling during repair can reduce life drastically. When repairing, make sure that you are connected with the same potential as the mass of the set via a wristband with resistance. Keep components and tools at this potential.

ESD



(NL) WAARSCHUWING

Alle IC's en vele andere halfgeleiders zijn gevoelig voor electrostatische ontladingen (ESD). Onzorgvuldig behandelen tijdens reparatie kan de levensduur drastisch doen verminderen. Zorg ervoor dat u tijdens reparatie via een polsband met weerstand verbonden bent met hetzelfde potentiaal als de massa van het apparaat. Houd componenten en hulpmiddelen ook op ditzelfde potentiaal.

(F) ATTENTION

Tous les IC et beaucoup d'autres semi-conducteurs sont sensibles aux décharges statiques (ESD). Leur longévité pourrait être considérablement écourtée par le fait qu'aucune précaution n'est prise à leur manipulation. Lors de réparations, s'assurer de bien être relié au même potentiel que la masse de l'appareil et enfilez le bracelet seriti d'une résistance de sécurité. Veiller à ce que les composants ainsi que les outils que l'on utilise soient également à ce potentiel.

(D) WARNUNG

Alle ICs und viele andere Halbleiter sind empfindlich gegenüber elektrostatischen Entladungen (ESD). Unvorsichtige Behandlung im Reparaturfall kann die Lebensdauer drastisch reduzieren. Sorgen Sie dafür, daß Sie im Reparaturfall über ein Pulsarmband mit Widerstand mit dem Massepotential des Gerätes verbunden sind. Halten Sie Bauteile und Hilfsmittel ebenfalls auf diesem Potential.

(I) AVVERTIMENTO

Tutti IC e parecchi semi-conduttori sono sensibili alle scariche statiche (ESD). La loro longevità potrebbe essere fortemente ridotta in caso di non osservazione della più grande cauzione alla loro manipolazione. Durante le riparazioni occorre quindi essere collegato allo stesso potenziale che quello della massa dell'apparecchio tramite un braccialetto a resistenza. Assicurarsi che i componenti e anche gli utensili con quali si lavora siano anche a questo potenziale.

(GB)

Safety regulations require that the set be restored to its original condition and that parts which are identical with those specified be used. Safety components are marked by the symbol

SAFETY



(NL)

Veiligheidsbepalingen vereisen, dat het apparaat in zijn oorspronkelijke toestand wordt teruggebracht en dat onderdelen, identiek aan de gespecificeerde, worden toegepast. De Veiligheidsonderdelen zijn aangeduid met het symbool

(F)

Les normes de sécurité exigent que l'appareil soit remis à l'état d'origine et que soient utilisées les pièces de rechange identiques à celles spécifiées. Les composants de sécurité sont marqués

(D)

Bei jeder Reparatur sind die geltenden Sicherheitsvorschriften zu beachten. Der Originalzustand des Gerätes darf nicht verändert werden. Für Reparaturen sind Originalersatzteile zu verwenden. Sicherheitsbauteile sind durch das Symbol markiert.

(I)

Le norme di sicurezza estigono che l'apparecchio venga rimesso nelle condizioni originali e che siano utilizzati i pezzi di ricambio identici a quelli specificati. Componenti di sicurezza sono marcati con

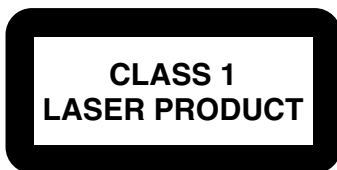

(GB) DANGER: Invisible laser radiation when open. AVOID DIRECT EXPOSURE TO BEAM.

(S) Varning !

Osynlig laserstrålning när apparaten är öppnad och spårren är urkopplad. Betrakta ej strålen.

(DK) Advarsel !

Usynlig laserstrålning ved åbning når sikkerhedsafbrydere er ude af funktion. Undgå udsættelse for stråling.

(FIN) Varoitus !

Avatussa laitteen ja suojauslaitteen ohitettaessa olet alttiina näkymättömälle laserisäteilylle. Älä katso säteeseen !

(GB)

After servicing and before returning the set to customer perform a leakage current measurement test from all exposed metal parts to earth ground, to assure no shock hazard exists. The leakage current must not exceed 0.5mA.

(F)

"Pour votre sécurité, ces documents doivent être utilisés par des spécialistes agréés, seuls habilités à réparer votre appareil en panne".

TECHNICAL SPECIFICATIONS

GENERAL

Mains voltage	-/01 : 120 / 230 V
Mains frequency	-/01 : 50 / 60 Hz
Battery	: 9 V (R14/UM-2/C-size x 6)
Power consumption	: 12 W
Dimension (W x H x D)	: 360 x 225 x 152mm
Weight	: 2.3 Kg

AMPLIFIER

Output power	mains : 2 x 1 W
	battery : 2 x 1 W
Speaker impedance	: 2 x 8 ohm
Frequency response	: 100 Hz - 10 kHz (± 3 dB)

TUNER - FM SECTION

Tuning range	: 87.5 - 108 MHz
IF frequency	: 10.7 MHz \pm 0.2 MHz
Sensitivity	: 28 dBf at 26dB S/N
Selectivity	: 24 dB at 300kHz
IF rejection	: 65 dB
Image rejection	: 26 dB

TUNER - AM SECTION

Tuning range	: 512 - 1635 kHz
IF frequency	: 468 kHz \pm 3 kHz
Sensitivity	: 4000 μ V/m at 26dB S/N
Selectivity	: 20 dB
IF rejection	: 70 dB
Image rejection	: 32 dB

AUDIO CASSETTE RECORDER

Number of tracks	: 1 stereo
Tape speed	: 4.76 cm/sec \pm 3%
Wow & flutter	: < 0.48 JIS UWTD
Fast wind/rewind C60	: 130 sec.
Frequency response P/B	: 125 - 8000 Hz
S/N ratio	: \geq 36 dB

COMPACT DISC

Frequency response	: 100 Hz - 10 kHz
S/N ratio	: 60 dB
Channel difference 1 kHz	: 2 dB
Channel crosstalk 1 kHz	: 40 dB
Laser wavelength	: 780 \pm 20 nm
Laser light power	: < 0.5 mW

SERVICE TOOLS

Audio signal disc SBC 429.....	4822 397 30184
Playability test disc SBC 444.....	4822 397 30245
Test disc 5 (disc without errors) +	
Test disc 5A (disc with dropout errors, black spots and fingerprints)	
SBC 426/426A.....	4822 397 30096
Burn in test disc (65 min. 1kHz signal at -30 dB level without "pause").....	4822 397 30155

AVAILABLE ESD PROTECTION EQUIPMENT

anti-static table mat large 1200x650x1.25mm	4822 466 10953
small 600x650x1.25m	4822 466 10958
anti-static wristband	4822 395 10223
connection box (3 press stud connections, 1M Ω)	4822 320 11307
extendible cable (2m, 2M Ω , to connect wristband to connection box)	4822 320 11305
connecting cable (3m, 2M Ω , to connect table mat to connection box)	4822 320 11306
earth cable (1M Ω , to connect any product to mat or to connection box)	4822 320 11308
KIT ESD3 (combining all 6 prior products - small table mat)	4822 310 10671
wristband tester	4822 344 13999

SERVICE MEASUREMENT

Tuner SW

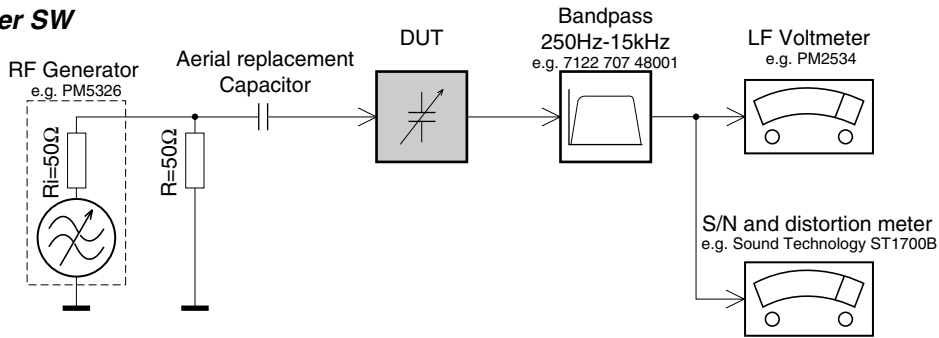

To avoid atmospheric interference all AM-measurements have to be carried out in a Faraday«s cage. Use a bandpass filter (or at least a high pass filter with 250Hz) to eliminate hum (50Hz, 100Hz).

Tuner AM (MW,LW)

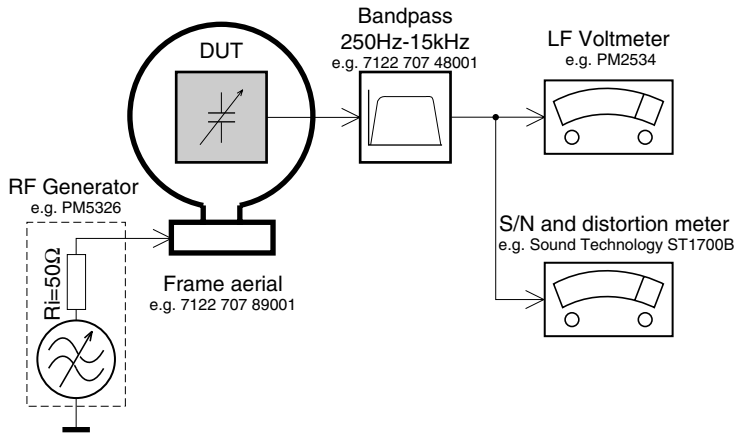

To avoid atmospheric interference all AM-measurements have to be carried out in a Faraday«s cage.

CD

Use Audio Signal Disc SBC429 4822 397 30184 (replaces test disc 3)
L.P.F. = 13th order filter 4822 395 30204

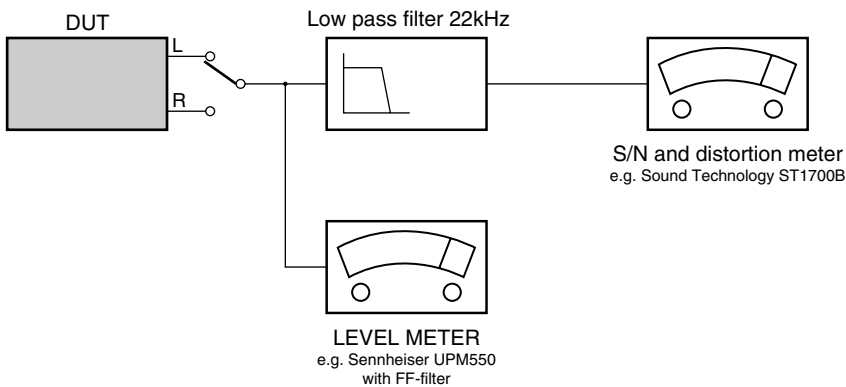

CONNECTIONS AND CONTROLS

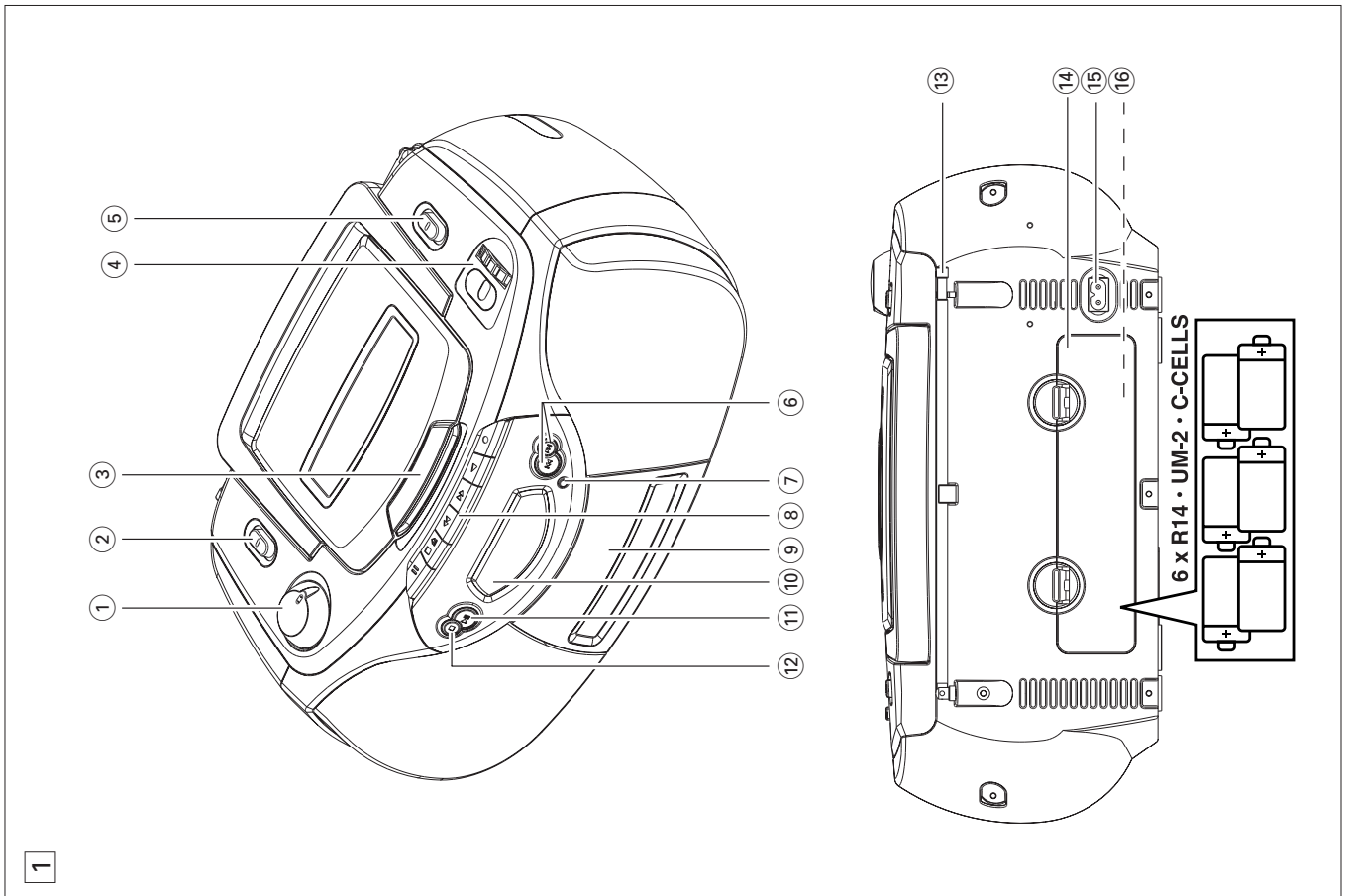
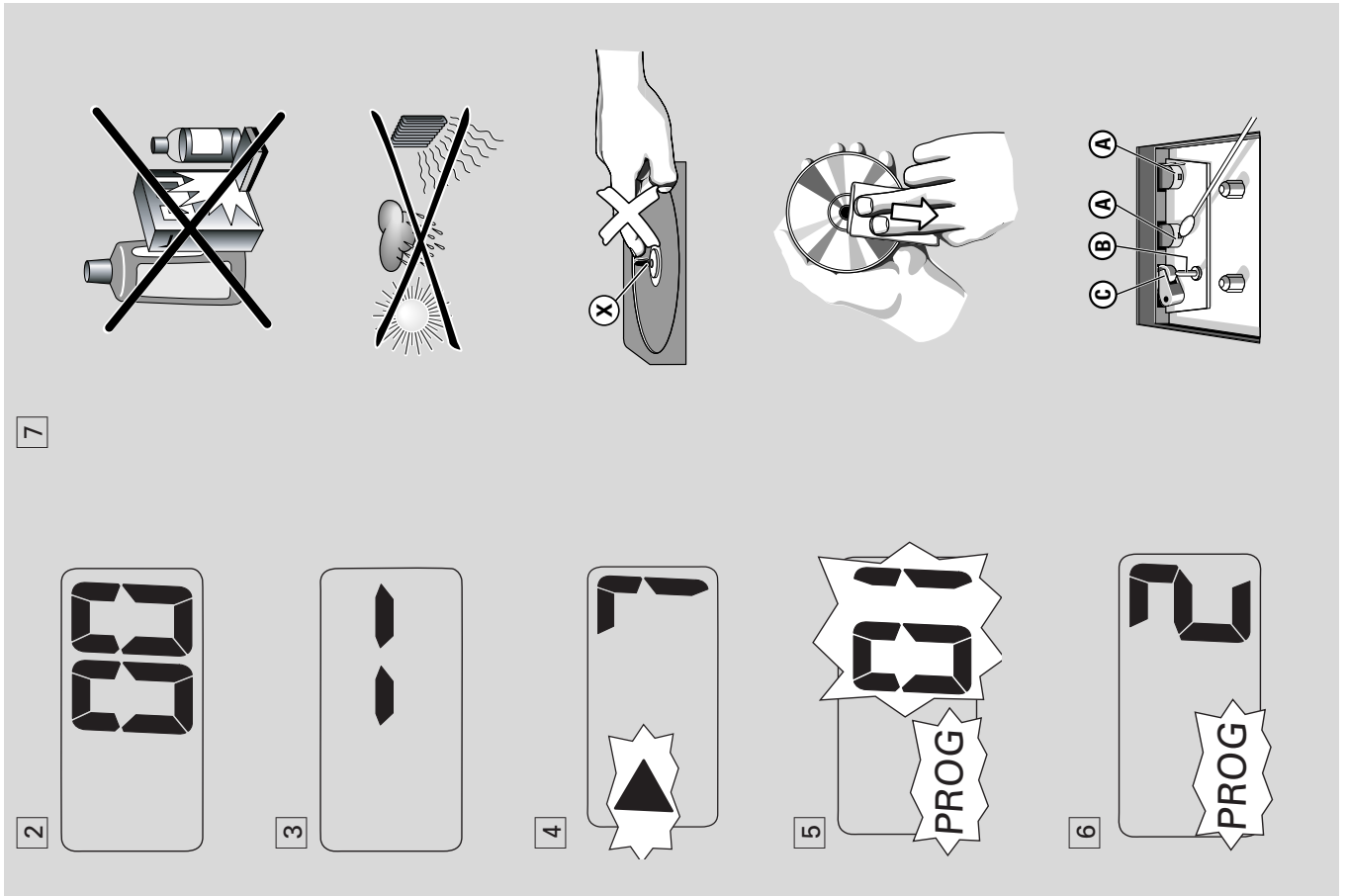

English

Top and front panels (See **1**)

- VOLUME** – to adjust volume level
- Source selector** : **CD, TUNER, TAPE/POWER OFF**
– selects CD, tuner or tape source of sound
– power off switch
- CD door**
- TUNING** – tunes to radio stations
- BAND** – selects waveband
- PREVIOUS, NEXT** **◀▶**
– skips or searches a passage/track backwards or forward
- PROG** – programs and reviews programmed track numbers
- CASSETTE RECORDER keys:**

II – pauses playback or recording

■ – stops the tape;

– opens the cassette holder

◀◀ or **▶▶** – fast rewinds/ winds tape

▶ – starts playback

● – starts recording

9 **Cassette door**

10 **CD Display** – shows the CD functions

11 **PLAY/PAUSE ▶II** - starts or pauses CD playback.

12 **STOP ■** – stop playback;

– erases a CD program.

Back panel

13 **Telescopic antenna** - improves FM reception.

Note: AM band antenna is built into set (see Tuner reception)

Controls/Power Supply

14 **Battery door** - open to insert 6 x 1.5V **R-14/ UM2/ C-cells.**

15 **AC POWER/MAINS** - inlet for power cord.

16 **Voltage selector** – (inside the battery compartment, not all versions) adjust to match the local voltage 110/220V before plugging in the set.

CAUTION

Use of controls or adjustments or performance of procedures other than herein may result in hazardous radiation exposure or other unsafe operation.

Power Supply

Whenever convenient, use the mains supply cord if you want to conserve battery life. Make sure you remove the plug from the set and wall outlet before inserting batteries.

Batteries (not included)

- Open the battery compartment and insert six batteries, type **R-14, UM-2** or **C-cells**, (preferably alkaline) with the correct polarity as indicated by the “+” and “-” symbols inside the compartment. (See **1**)
- Replace the compartment door, making sure the batteries are firmly and correctly in place. The set is now ready to operate.

Batteries contain chemical substances, so they should be disposed of properly.

Incorrect use of batteries can cause electrolyte leakage and will corrode the compartment or cause the batteries to burst:

Power Supply

- Do not mix battery types: e.g. alkaline with carbon zinc. Only use batteries of the same type for the set.
- When inserting new batteries, do not try to mix old batteries with the new ones.
- Remove the batteries if the set is not to be used for a long time.

Using AC Mains

- Check if the power/mains voltage, as shown on the type plate located on the bottom of the set, corresponds to your local power supply. If it does not, consult your dealer or service center.
- Connect the power cord to the AC POWER/MAINS inlet and the wall socket. The mains lead is now connected and ready for use.
- To switch the set off completely, withdraw the power cord from the wall socket.
- Disconnect the mains lead from the wall socket to protect your set during heavy thunderstorms.

The type plate is located on the bottom of the set.

Switching POWER on/off:

Save energy

To avoid unnecessary energy consumption, always adjust the **source selector** to **TAPE/POWER OFF** after using the set. Also check that the tape deck keys are released.

General operation

- To select your sound source adjust the **source selector** to : **CD, TUNER** or **TAPE/POWER OFF.**

INSTRUCTION FOR USE

Tuner/CD Player

- Adjust the sound with the **VOLUME** control.
- To switch off the set, adjust the source selector to **TAPE/POWER OFF** position and check the cassette keys are released.

Tuner reception

- Adjust the **source selector** to **TUNER.**
- Adjust **BAND** to select your desired waveband.
- Turn **TUNING** to tune to a station.
 - For **FM** band signals, extend and turn the telescopic antenna for best reception. Reduce its length if the signal is too strong.
 - For **MW (AM)** band signals, the set uses a built-in antenna. Direct this antenna for best reception by turning the whole set.
- To switch off the radio, adjust the source selector to **TAPE/POWER OFF** position and check the cassette keys are released.

CD Player

Display indication for CD functions:

- : (See **2**) CD door open / no disc/ error in CD operation or with the CD/ CD-R is blank or not finalized (see Troubleshooting)
- - -**: (See **3**) reading disc contents
- In stop mode**: total track number
- During CD playback**: ▶ and current track number
- ▶**: (See **4**) playback on pause
- PROG**: when CD program is active

Playing a CD

This CD player plays Audio Discs including CD-Recordables.

CD Player

- CD-RWs, MP3 CD-ROMs, CD-I, CDV, VCD, DVD or computer CDs are not possible for playback.

- 1 Adjust the **source selector** to **CD**.
- 2 Open the CD door, and Insert a CD/ CD-R with the printed side facing up and press the CD door gently close.

- 3 Press **PLAY/PAUSE** **▶||** on the set to start playback.

- 4 To pause playback press **PLAY/PAUSE** **▶||**.
→ **▶** flashes.

- 5 To resume, press **PLAY/PAUSE** **▶||** again

- 6 To stop CD play, press **STOP** **■**.

- 7 To switch off the set, adjust the **source selector** to **TAPE/POWER OFF** position and check if the cassette keys are released.

Note : CD play will also stop when:

- you open the CD compartment;
- you select **TUNER** or **TAPE/POWER OFF** sound source;
- the CD has reached to the end.

Selecting a different track

During playback you can use **◀◀ / ▶▶** to select a particular track.

- If you have selected a track number in the stop or pause position, press **PLAY/PAUSE** **▶||** to start playback.

- Press **▶▶** once briefly for the next track, or press repeatedly until the desired track number appears in the display.

- Press **◀◀** once briefly to return to the beginning of a current track.

- Press **◀◀** more than once briefly for a previous track.

Finding a passage within a track

- 1 During playback, press and hold down **◀◀ / ▶▶**.

- The CD is played at high speed and low volume.

- 2 When you recognize the passage you want release **◀◀ / ▶▶**.

- 3 Normal playback resumes.

Note : When searching within a final track and you reach the end of the last track, the CD goes to stop mode.

Programming track numbers

You may store up to 20 tracks in the desired sequence. If you like, store any track more than once.

- 1 In the stop position, press **PROG** to activate programming.

→ Display shows **07** / indicating the start of the program. **PROG** and **07** / flashes. (See [5])

- 2 Press **◀◀** or **▶▶** to select your desired track number.

- 3 Press **PROG** to store the desired track number.

→ Display shows **07**, **2** and flashes (up to **20** in sequence) indicating the next available program location. (See [6])

- 4 Repeat steps **2** to **3** to select and store all desired tracks in this way.

→ If you attempt to store more than 20 tracks, no track can be selected and the display will review your programmed tracks.

- 5 To play your program, press **PLAY/PAUSE** **▶||**.

CD Player

To review your set program

In the stop position, press **PROG** once.

→ Display shows the stored tracks in sequence.

Erasing a program

You can erase the contents of the memory by:

- press **STOP** **■** (twice during playback or; once in the stop position;
 - selecting **TUNER** or **TAPE/POWER OFF** sound source;
 - opening the CD door;
- Display: **PROG** disappears.

Cassette playback

- 1 Adjust the **source selector** to **TAPE/POWER OFF**.

- 2 Press **▶▶** to open the cassette holder and insert a cassette and close the deck.

- 3 Press **▶** to start playback.

- 4 To pause playback press **||** To resume, press the key again.

- 5 By pressing **◀◀** or **▶▶** , fast winding of the tape is possible in both directions. To stop fast winding, press **▶▶**

- 6 To stop the tape, press **▶▶**.

The keys are automatically released at the end of a tape and the set switched off (unless PAUSE mode **||** has been activated.)

General information on recording

- Recording is permissible insofar as copyright or other rights of third parties are not infringed.
- For recording, use only NORMAL type cassettes (IEC type I) on which the tabs have not yet been broken. This deck is not suited for recording on CHROME (IEC II) or METAL (IEC IV) type cassettes.

INSTRUCTION FOR USE

Cassette Recorder

- The best recording level is set automatically. Altering the **VOLUME** will not affect the recording.

- To protect a tape from accidental erasure, break out the tabs. If you wish to record again, cover the tabs with a piece of adhesive tape.

Synchro Start CD recording

- 1 Select **CD** source.
- 2 Insert a CD and if desired, program track numbers.
- 3 Press **▶▶** to open the cassette holder. Insert a blank tape and close the deck.
- 4 Press **●** to start recording.

→ Playing of the CD program starts automatically from the beginning of the program. It is not necessary to start the CD player separately.

- 5 For brief interruptions press **||** To resume recording, press **||** again.

- 6 To stop recording, press **▶▶**.

Recording from the Radio

- 1 Adjust the **source selector** to **TUNER** to select your desired waveband.

- 2 Tune to the desired radio station (see **Tuner reception**).

- 3 Press **▶▶** to open the cassette holder. Insert a blank tape and close the deck.

- 4 Press **●** to start recording.

- 5 For brief interruptions press **||** To resume recording, press **||** again.

- 6 To stop recording, press **▶▶**.

INSTRUCTION FOR USE





Maintenance

Precautions & General Maintenance (See [7])

- Place the set on a hard and flat surface so that the system does not tilt.
- Do not expose the set, batteries, CDs to humidity, rain, sand or excessive heat caused by heating equipment or direct sunlight.
- Do not cover the set. Adequate ventilation with a minimum gap of 6 inches between the ventilation holes and surrounding surfaces is necessary to prevent heat build-up.
- The mechanical parts of the set contain self-lubricating bearings and must not be oiled or lubricated.
- To clean the set, use a dry cloth. Do not use any cleaning agents containing alcohol, ammonia, benzene or abrasives as these may harm the housing.
- Sudden changes in the surrounding temperature can cause condensation on the lens of your CD player. Playing a CD is then not possible. Do not attempt to clean the lens but leave the set in a warm environment until the moisture evaporates.
- Always close the CD-tape door to avoid dust on the lens.
- To clean the CD, wipe in a straight line from the center towards the edge using a soft, lint-free cloth. Do not use cleaning agents as they may damage the disc.
- Never write on a CD or attach any stickers to it.

Tape deck maintenance (See [7])

To ensure quality recording and playback of the tape deck, clean parts (A), (B) and (C) as shown, once a month. Use a cotton bud slightly moistened with alcohol or a special head cleaning fluid to clean the deck.

- 1 Open the cassette holder by pressing .
- 2 Press  and clean the roller (C).
- 3 Press  and clean the heads (A), and the capstan (B).
- 4 After cleaning, press .
 - Cleaning of the heads can also be done by playing a cleaning cassette through once.

CD player and CD handling (See [7])

- If the CD player cannot read CDs correctly, use a cleaning CD to clean the lens before taking the set to repair.
- The lens of the CD player should never be touched!

Troubleshooting

If a fault occurs, first check the points listed below before taking the set for repair. If you are unable to remedy a problem by following these hints, consult your dealer or service centre.

WARNING: Do not open the set as there is a risk of electric shock. Under no circumstances should you try to repair the set yourself, as this will invalidate the guarantee.

Problem	indication
<ul style="list-style-type: none"> – Possible cause • Remedy 	<ul style="list-style-type: none"> – No CD inserted • Insert a CD – CD badly scratched or dirty • Replace/ clean CD, see Maintenance – Laser lens steamed up • Wait until lens has cleared – CD-R is blank or not finalized/ CD-RW inserted • Use a finalized CD-R or suitable CD Audio disc only
No sound /power <ul style="list-style-type: none"> – Volume not adjusted • Adjust the VOLUME – Power cord not securely connected • Connect the AC power cord properly – Batteries dead/ incorrectly inserted • Insert (fresh) batteries correctly 	
Display does not function properly/ No reaction to operation of any of the controls <ul style="list-style-type: none"> – Electrostatic discharge • Switch off and unplug the set. Reconnect after a few seconds 	

Poor cassette sound quality

- Dust and dirt on the heads, etc.
- Clean deck parts, see Maintenance
- Use of incompatible cassette types (METAL or CHROME)
- Only use NORMAL (IEC I) for recording

Recording does not work

- Cassette tab(s) may be broken
- Apply adhesive tape over the missing tab space

The CD skips tracks

- CD damaged or dirty
- Replace or clean CD
- Program is active
- Quit program mode

For more information on operation instruction please visit Philips Audio internet site :

<http://www.audio.philips.com>

DISASSEMBLY DIAGRAM

- A. REMOVE BACK CABINET ASSEMBLY**
- REMOVE SCREWS A1(3x10) 3PCS
 - REMOVE SCREWS A2(3x30) 5PCS
 - REMOVE BACK CABINET

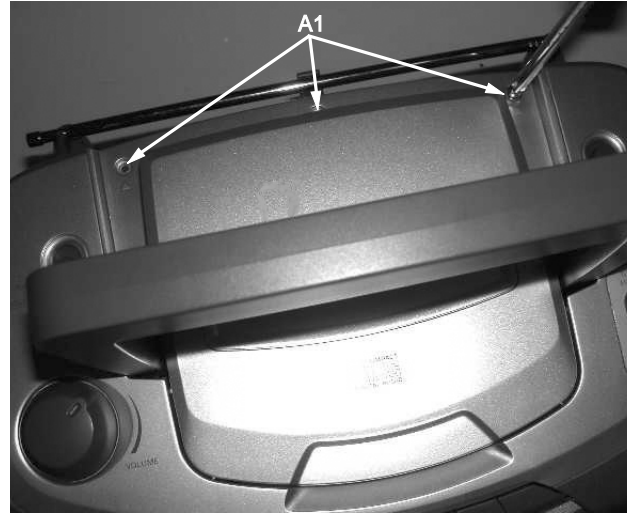

- B. REMOVE HANDLE**
- PRESS DOWN THE STOPPER AND PULL THE HANDLE OUT
 - REMOVE HANDLE

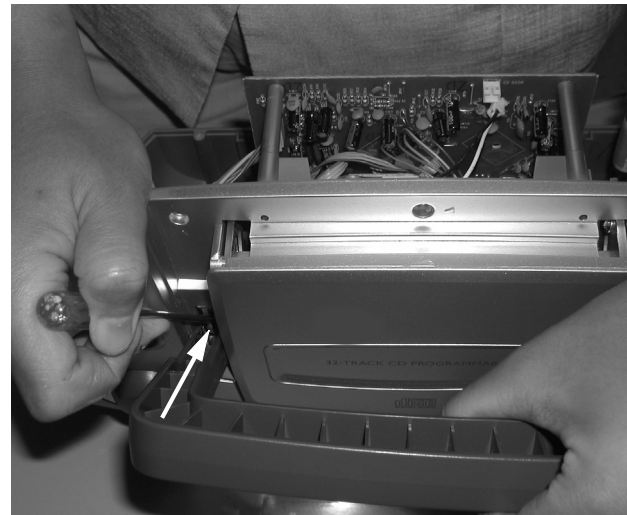

- C. REMOVE TOP CABINET ASSEMBLY**
- REMOVE SCREWS C3(3x20) 2PCS
 - REMOVE SCREWS C4(3x10) 1PC
 - REMOVE TOP CABINET



- D. REMOVE DECK MECHANISM**
- REMOVE SCREWS D5(3x10) 4PCS
 - REMOVE SCREWS D6(2.5x10) 4PCS

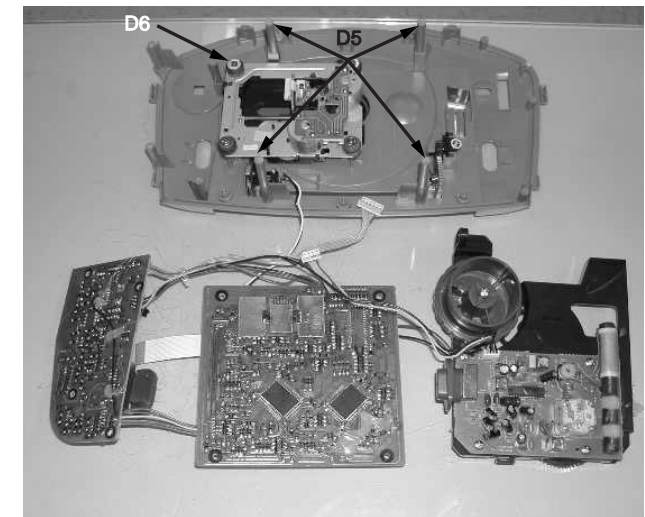

BLOCK DIAGRAM

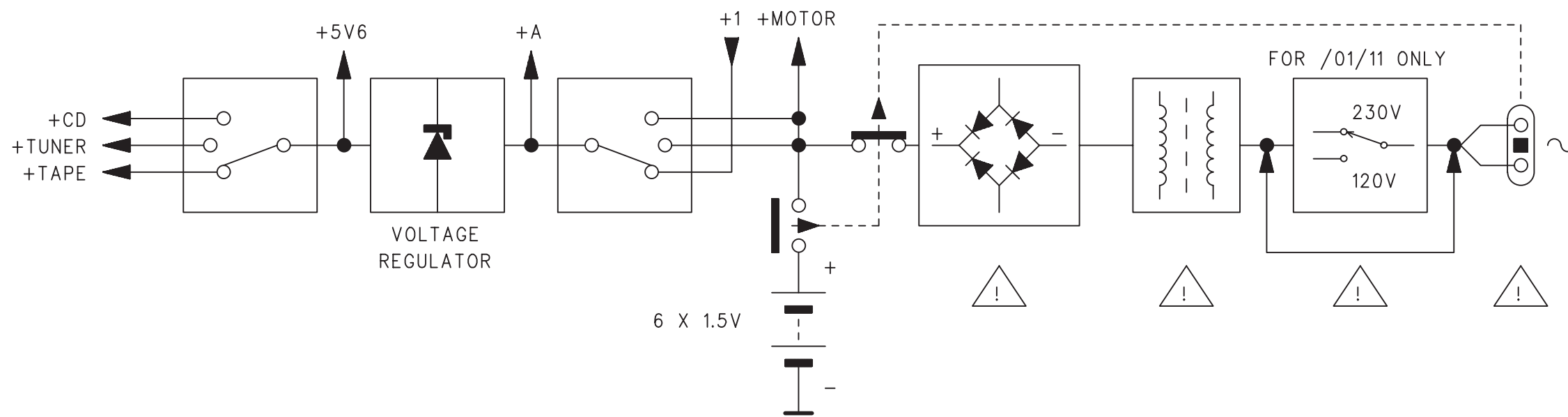
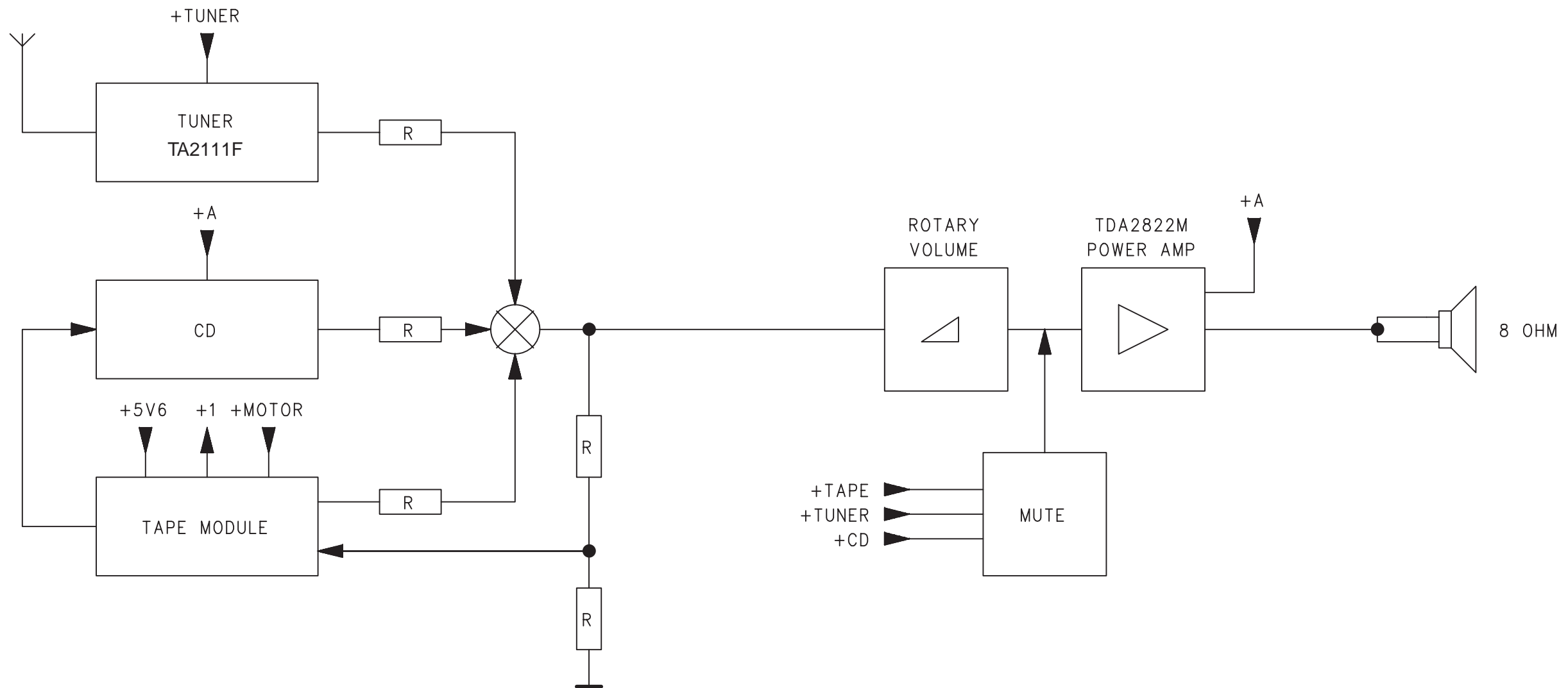

WIRING DIAGRAM

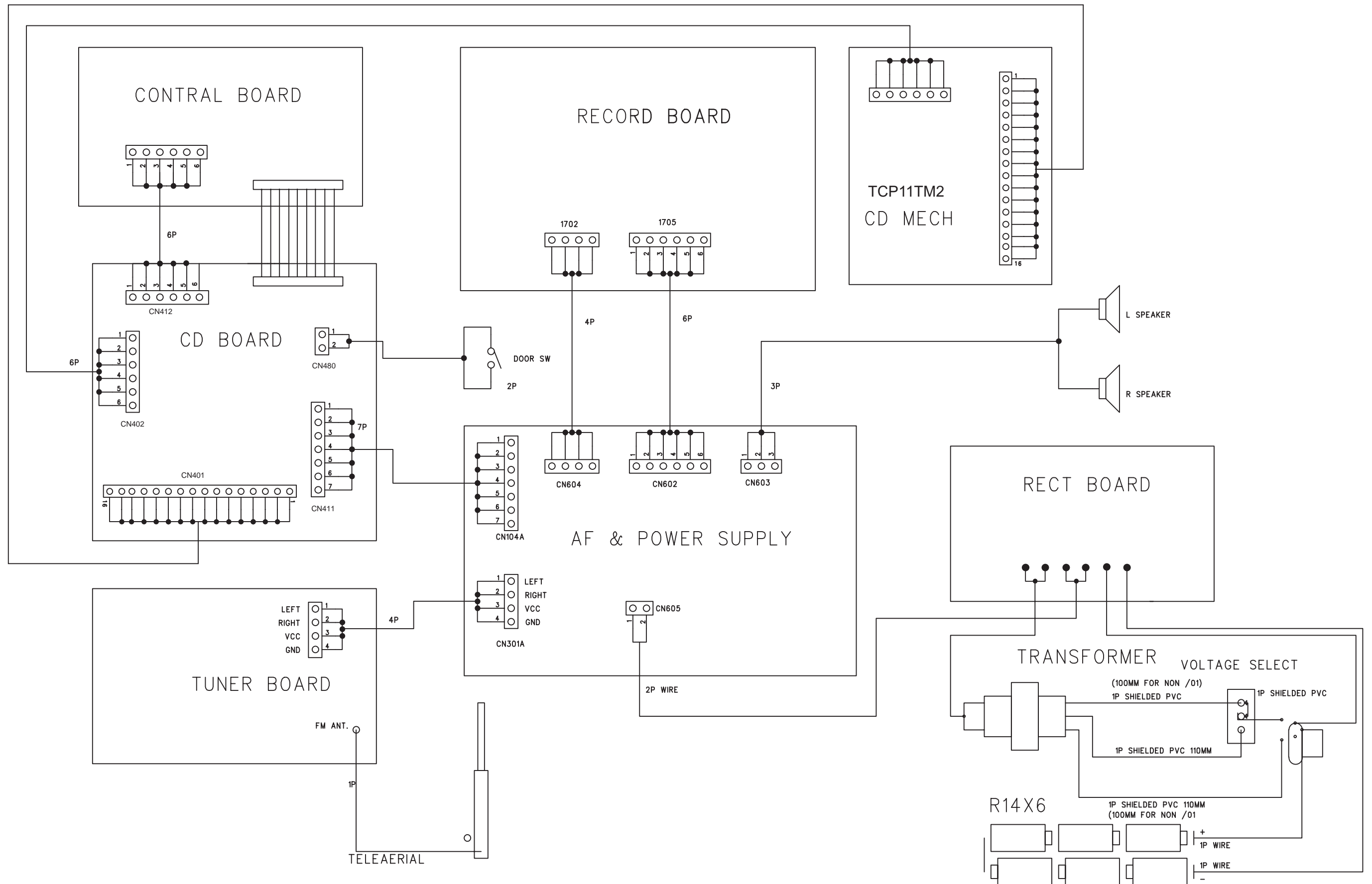

TUNER BOARD - CIRCUIT DIAGRAM

TUNER BOARD - ALIGNMENT PROCEDURE

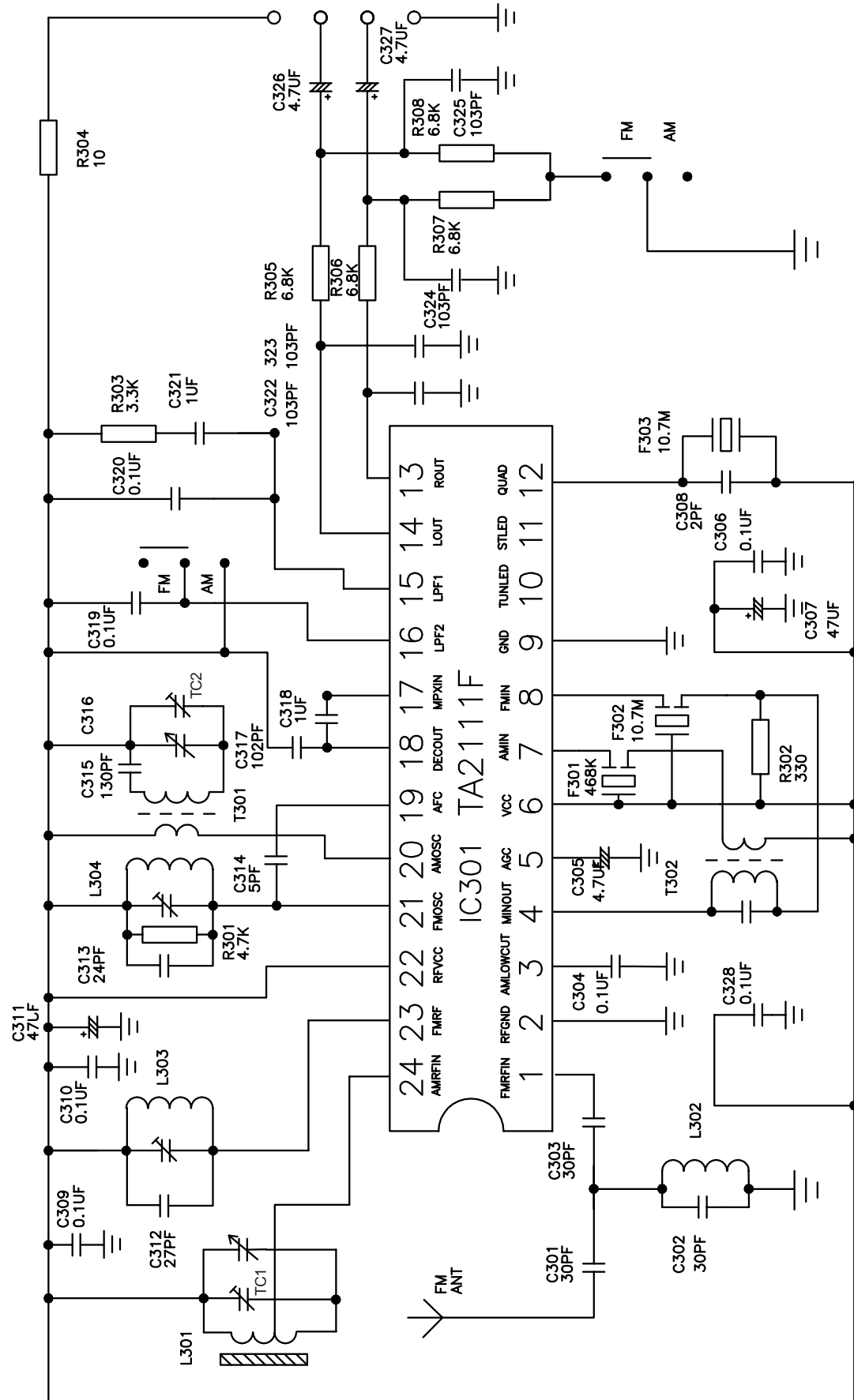

Alignment Procedure

Model No. AZ-1004/01

Instruments Required :

1. AM Signal Generator
2. FM Signal Generator
3. AM/FM if Sweep Generator
4. Dual Trace Oscilloscope
5. Solid State Voltage Meter (SSVM)
6. Frequency Counter
7. Nonmetallic Alignment Tools
8. Test Tape : Teac - MTT 113N (6.3 kHz) or Equiv.
9. Test Tape : Teac - MTT 111N (3 kHz) or Equiv.

Important

1. Check Power Source Voltage
2. Set the Function Switch to Band Being Aligned.
3. Volume Should Be Turned To Minimum.
4. Signal Input Should be Kept as Low as Possible.
5. AM Modulation : 1 kHz 30%
6. FM Modulation : 1 kHz 22.5 kHz DEV.

Radio Alignment

	Frequency	Input	Varian	Adjust	Output	Scope/Meter
MW IF						
	468 kHz	LOOP ANT AM Coil	MIN.	T302	IC301 Pins 18	MAX.
MW IF						
	526.5 kHz	LOOP ANT AM Coil	MAX.	T301	IC301 Pins 18	MAX.
	1606.5 kHz		MIN.	TC2		MAX.
	600 kHz	LOOP ANT AM Coil	600 kHz	L301	IC301 Pins 18	MAX.
	1400 kHz		1400 kHz	TC1		MAX.
FM IF						
	10.7 MHz	IC301 Pins 4	MIN.		IC301 Pins 18	Symmetrical
FM IF						
	87.5 MHz	FM ANT. C301 Cer. Cap.	MAX.	L304	IC301 Pins 18	MAX.
	108.5 MHz		MIN.	FC1		MAX.
	90 MHz	FM ANT. C301 Cer. Cap.	90 MHz	L303	IC301 Pins 18	MAX.
	106 MHz		106 MHz	FC2		MAX.

TUNER BOARD - LAYOUT DIAGRAM

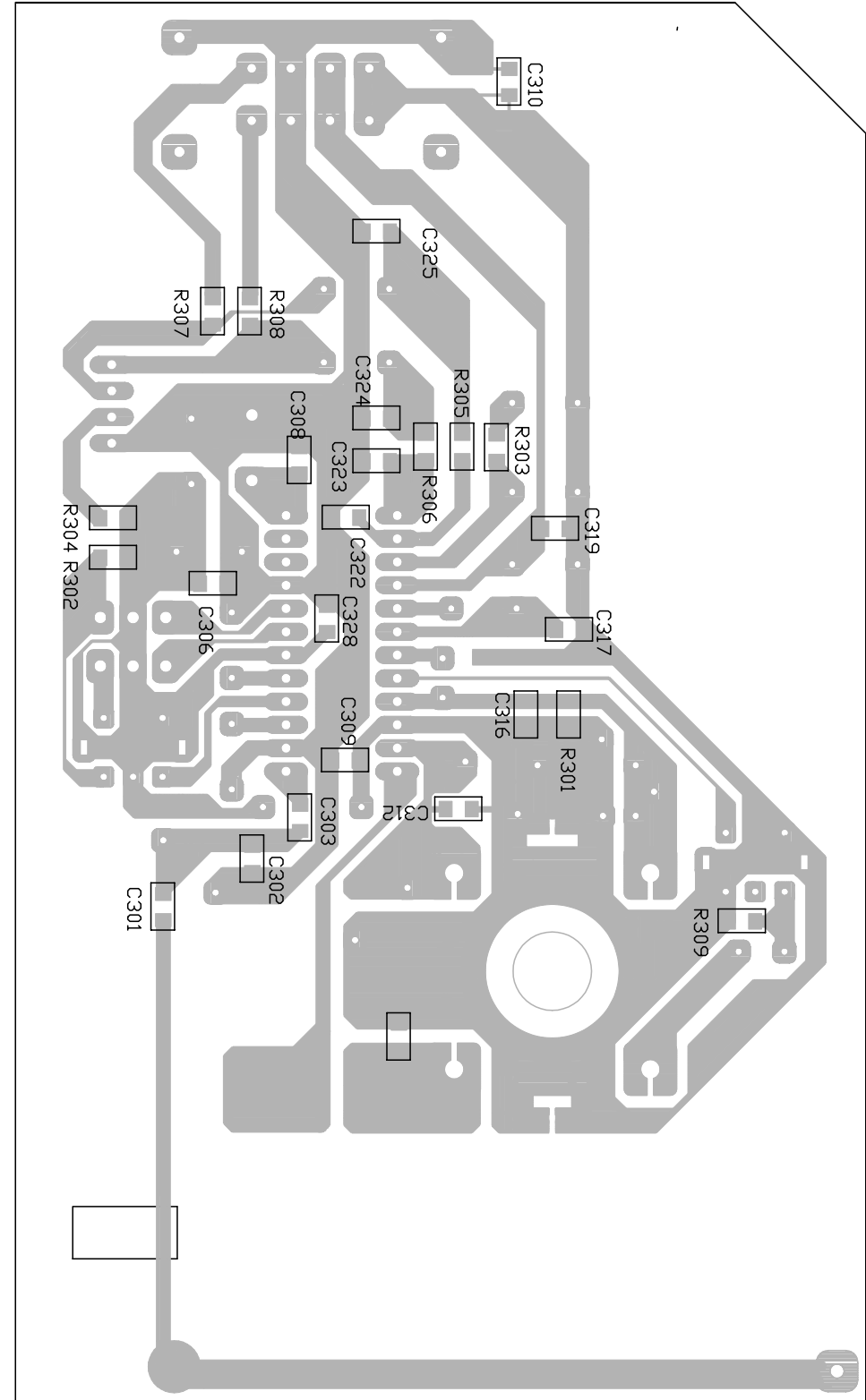
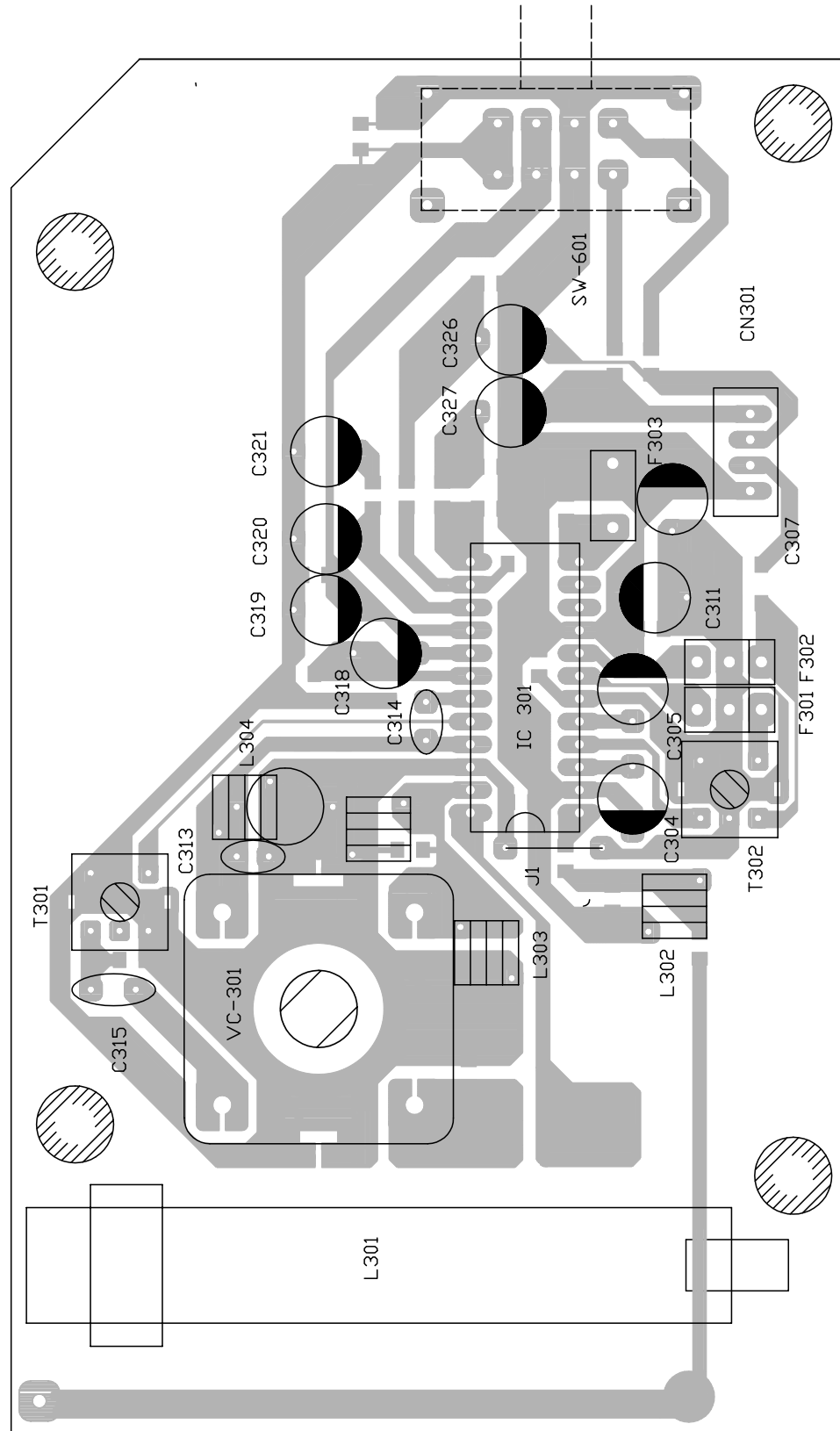

RECORDER BOARD - CIRCUIT DIAGRAM

71	D15	1707	C 3	1709	A14	2706	B 4	2711	F 6	2719	C 8	2727	F 7	2733	H13	2750	D 6	3703	D 3	3712	E 7	3720	F 7	3730	F12	3743	C 9	3761	G 6	7705	G 4	8702	E 1	9753	C13	T705	B14	T710	G11	T718	E 2	T724	E 2
73	E15	1707	G 7	1710	B15	2707	B 6	2712	E 7	2721	G 3	2728	C13	2734	G10	2751	H 6	3704	C 3	3713	G 3	3722	A 2	3731	G12	3744	G 9	3762	D 6	7705	C 4	8704	E15	9754	F11	T706	E14	T711	F14	T719	H13	T725	C 7
74	G 9	1707	C 7	1725	A15	2708	C 3	2714	C 3	2722	G 7	2729	C13	2735	G10	2760	E14	3706	D 4	3714	F 3	3723	A 2	3732	H13	3747	G12	5701	F11	8702	F 1	8704	E15	9758	D12	T707	B10	T712	F 5	T721	A14		
1702	G15	1707	E 9	2703	G 7	2709	G 3	2715	C 6	2723	G 5	2730	G11	2738	B 3	2799	E15	3707	B 5	3716	H 4	3726	B 9	3733	F 6	3748	B 3	6704	F11	8702	F 1	8705	F15	T701	A14	T708	B10	T716	F10	T722	G 7		
1707	F 3	1707	E12	2704	C 7	2710	G12	2716	D 5	2726	G 8	2732	G12	2739	B 1	3701	B 6	3710	D 8	3719	H 8	3727	E 9	3734	D11	3749	B 2	7702	H13	8702	E 1	8705	F15	T702	A14	T709	D14	T717	F 2	T723	F 2		

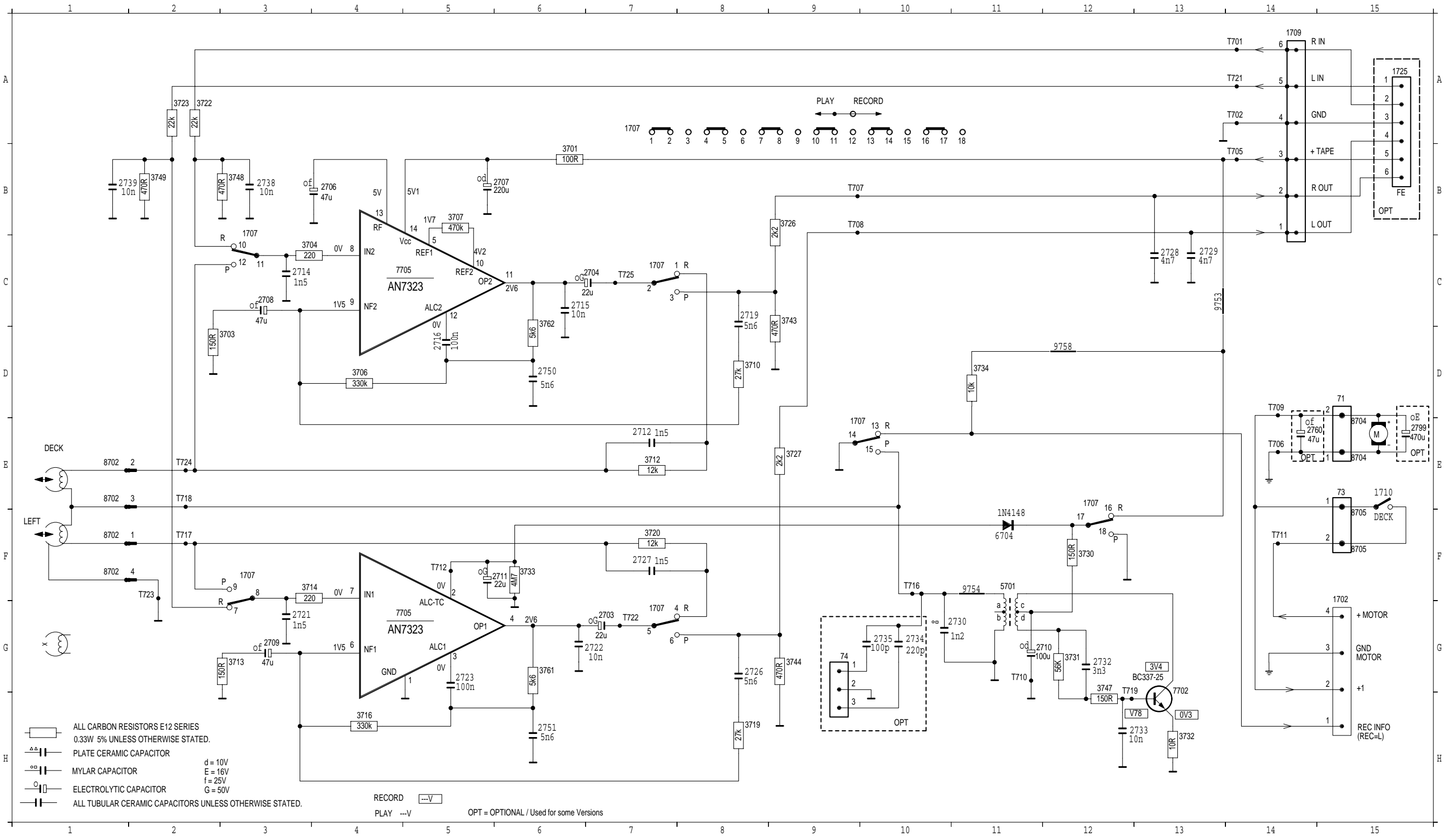

RECORDER BOARD - CIRCUIT DIAGRAM

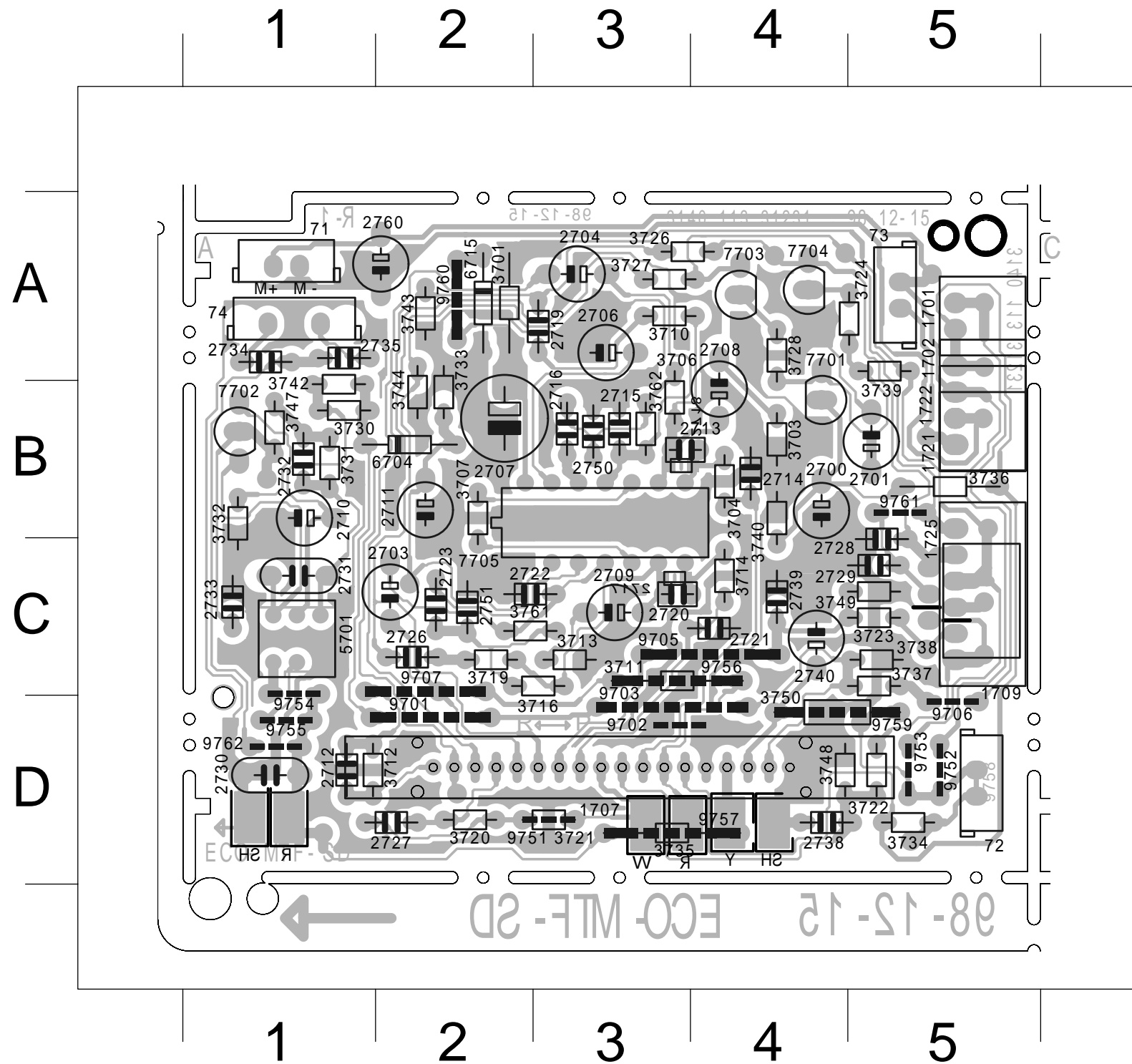

71 A 1	2729 C 5	3733 B 2	9756 C 3
72 D 5	2730 D 1	3734 D 5	9757 D 3
73 A 5	2731 C 1	3735 D 3	9759 D 4
74 A 1	2732 B 1	3736 B 5	9760 A 2
1701 A 5	2733 C 1	3737 C 5	9761 B 5
1702 B 5	2734 A 1	3738 C 5	9762 D 1
1707 D 3	2735 A 1	3739 A 5	T701 C 5
1709 C 5	2738 D 4	3740 B 4	T702 C 5
1721 B 5	2739 C 4	3742 B 1	T705 B 5
1722 B 5	2740 C 4	3743 A 2	T706 B 5
1725 C 5	2750 B 3	3744 B 2	T709 A 5
2700 B 4	2751 C 2	3747 B 1	T710 C 1
2701 B 5	2760 A 2	3748 D 4	T711 B 5
2703 C 2	3701 A 2	3749 C 5	T712 C 2
2704 A 3	3703 B 4	3750 D 4	T713 A 5
2706 A 3	3704 B 4	3761 C 2	T714 D 5
2707 B 2	3706 B 3	3762 B 3	T715 D 5
2708 B 4	3707 B 2	5701 C 1	T716 D 1
2709 C 3	3710 A 3	6704 B 2	T719 B 1
2710 B 1	3711 C 3	6715 A 2	T720 A 5
2711 B 2	3712 D 1	7701 B 4	T721 C 5
2712 D 1	3713 C 3	7702 B 1	T722 C 2
2713 B 3	3714 C 4	7703 A 4	T725 D 2
2714 B 4	3716 C 3	7704 A 4	T7707 A 4
2715 B 3	3719 C 2	7705 B 3	T7708 A 4
2716 B 3	3720 D 2	9701 D 2	
2717 C 3	3721 D 3	9702 D 3	
2718 B 3	3722 D 5	9703 D 3	
2719 A 3	3723 C 5	9705 C 4	
2720 C 3	3724 A 5	9706 D 5	
2721 C 4	3726 A 3	9707 C 2	
2722 C 2	3727 A 3	9751 D 3	
2723 C 2	3728 A 4	9752 D 5	
2726 C 2	3730 B 1	9753 D 5	
2727 D 2	3731 B 1	9754 C 1	
2728 C 5	3732 B 1	9755 D 1	

CASSETTE ADJUSTMENT

Adjustment	Cassette	SK	Deck 1	Measure on	Read on	Adjust with	Adjust to
Azimuth	10 kHz SBC420*	Tape	Play	H/P Jack	mV meter	Left hand Screw R/P head	max.
Motor Speed	3150 kHz SBC420*	Tape	Play	H/P Jack	Wow and flutter meter	Preset in motor	**a

* SBC420 : 4822 397 30071

**a The maximum permissible speed deviation is -3%.
Moreover, the wow and flutter value can be read.

CD / CONTROL BOARD - CIRCUIT DIAGRAM

AZ-1004CD

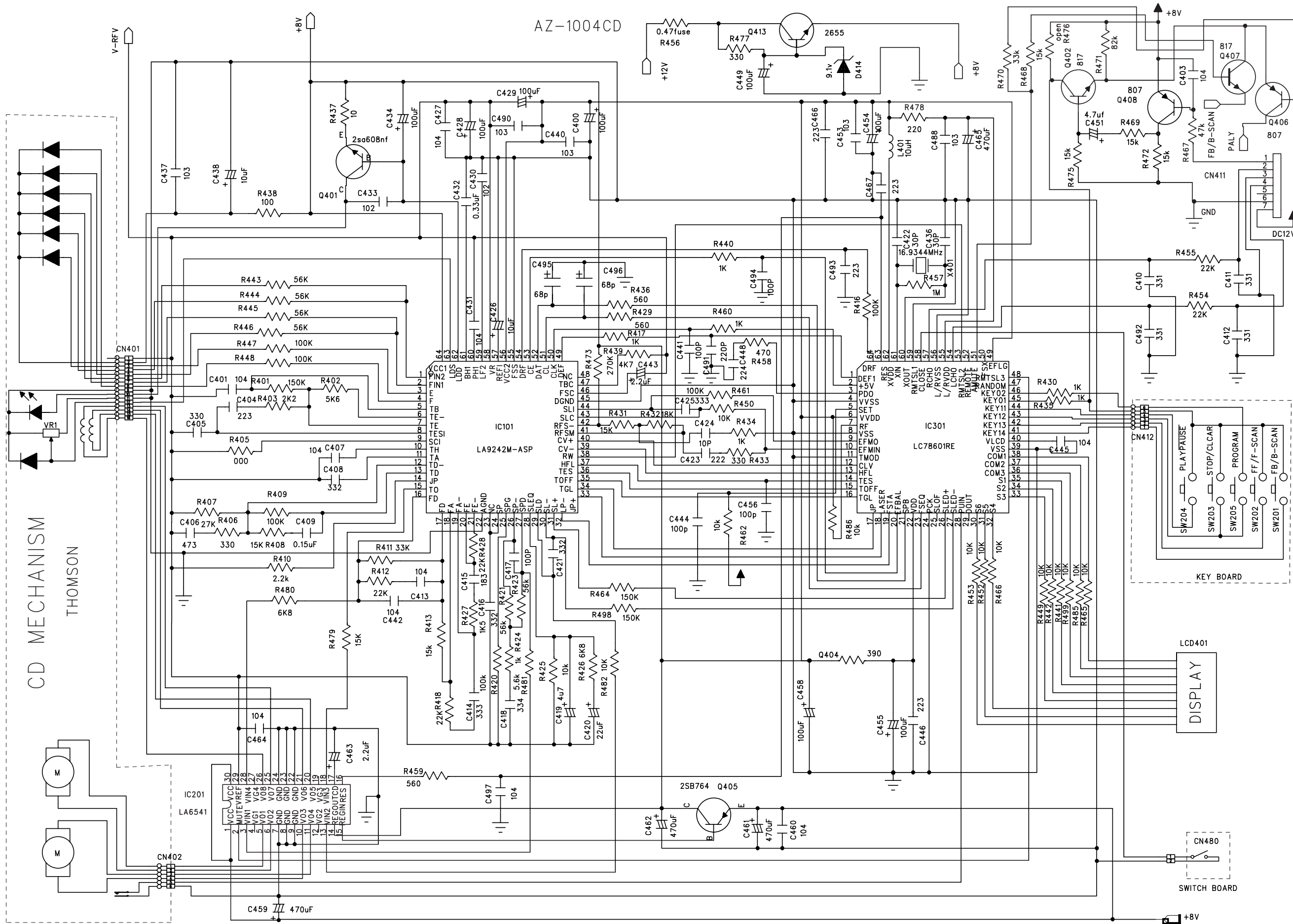

SWITCH BOARD

DISPLAY

KEY BOARD

CD MECHANISM
THOMSON

POWER BOARD - CIRCUIT DIAGRAM

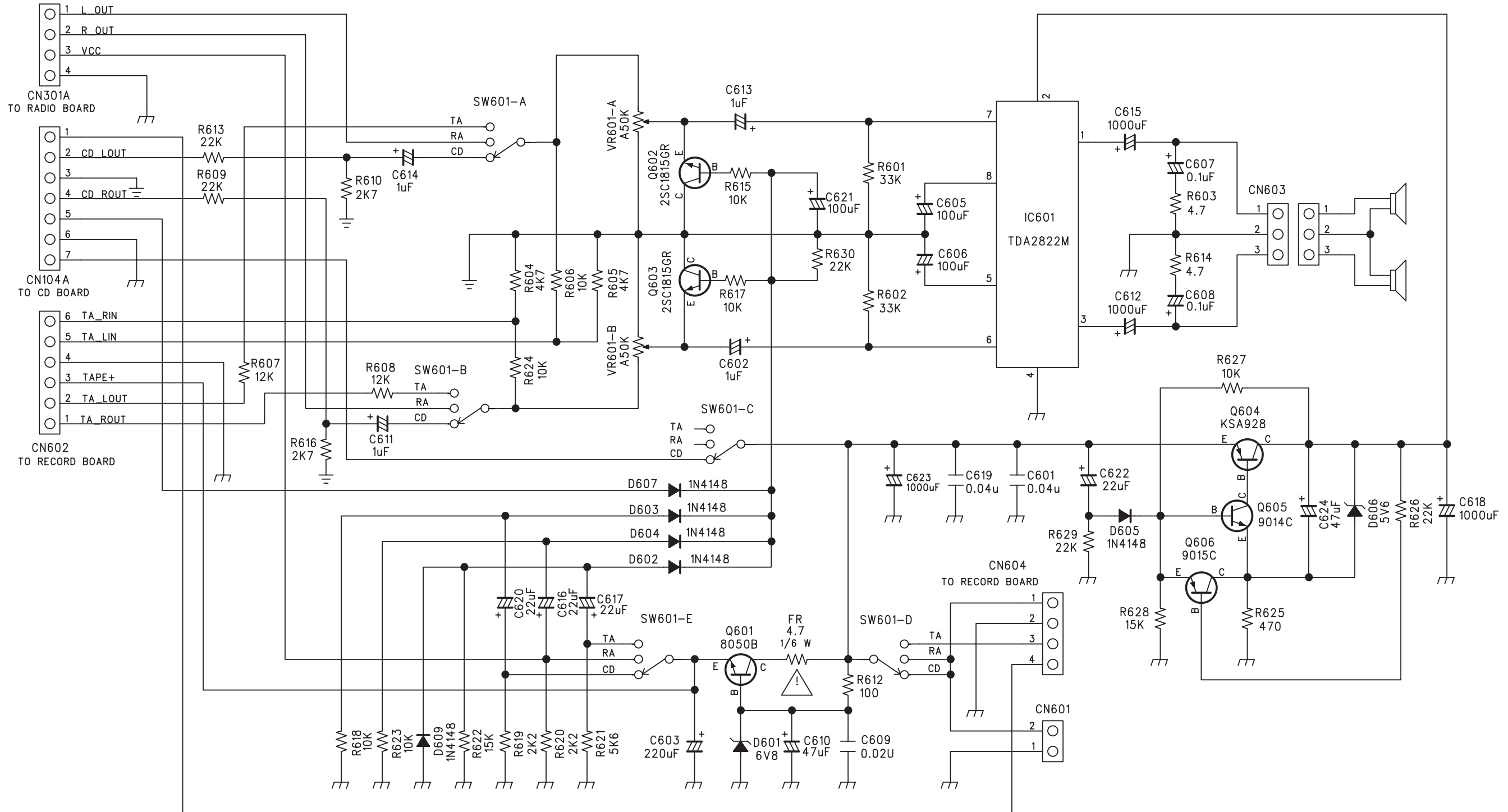

POWER BOARD - LAYOUT DIAGRAM

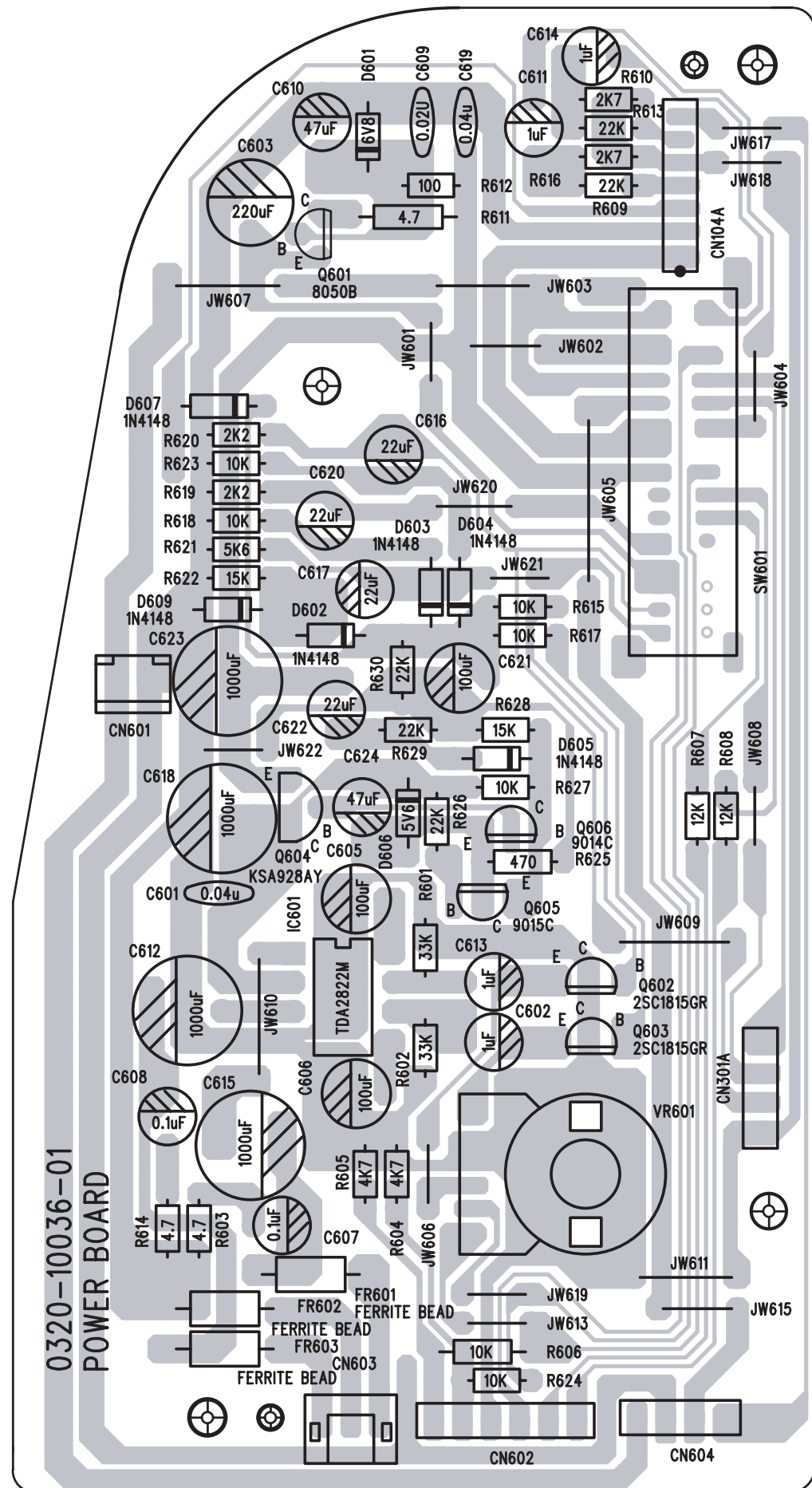

CD
RADIO
TAPE

RECTIFIER BOARD - CIRCUIT / LAYOUT DIAGRAM

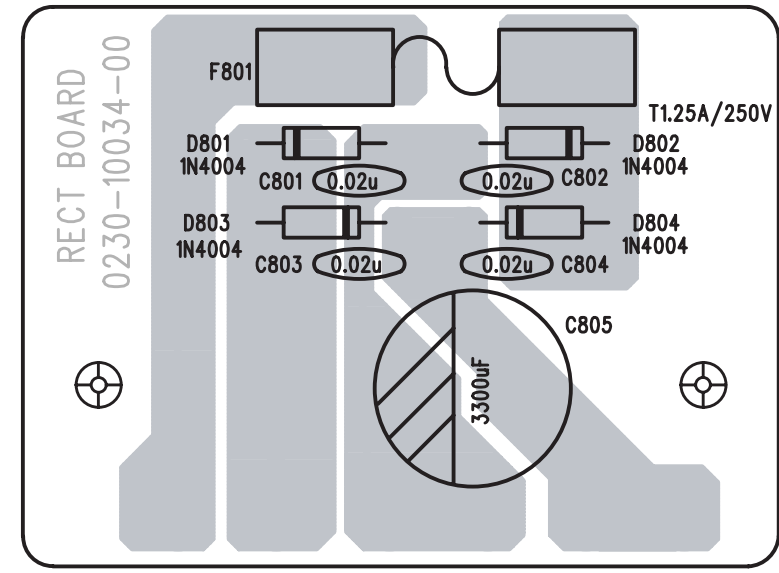
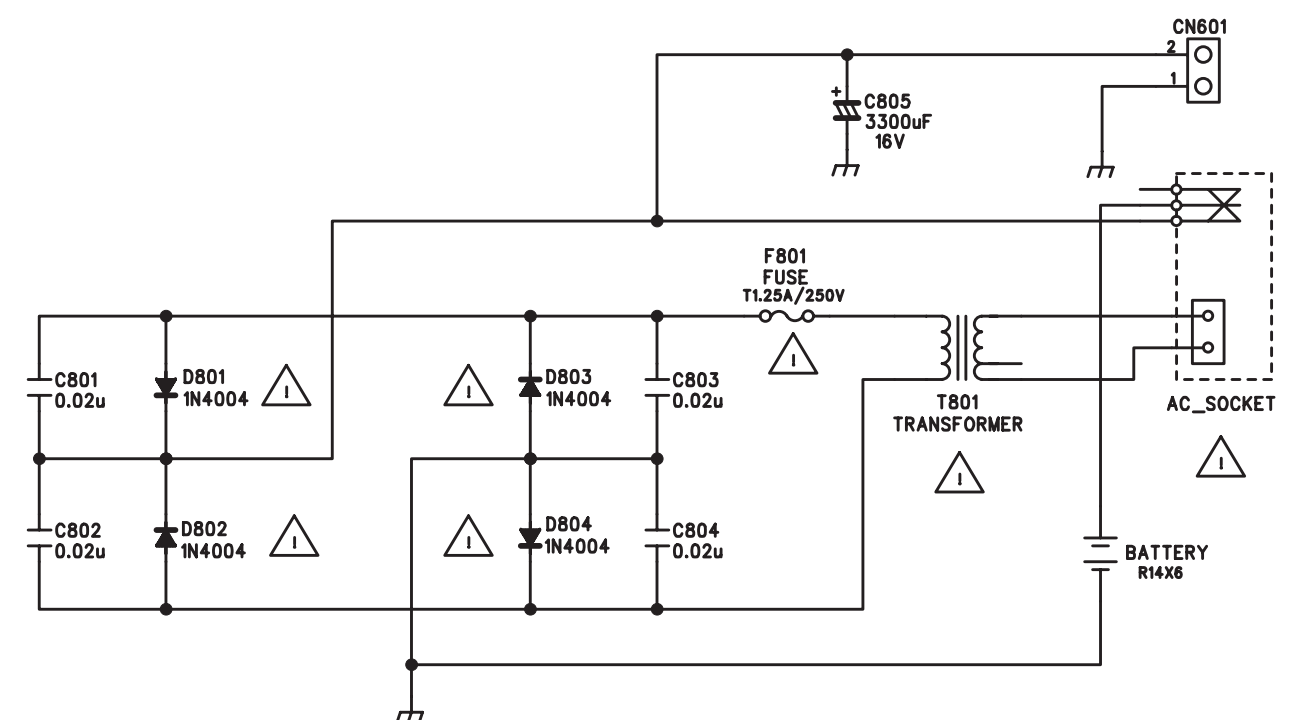

EXPLODED VIEW DIAGRAM - CABINET

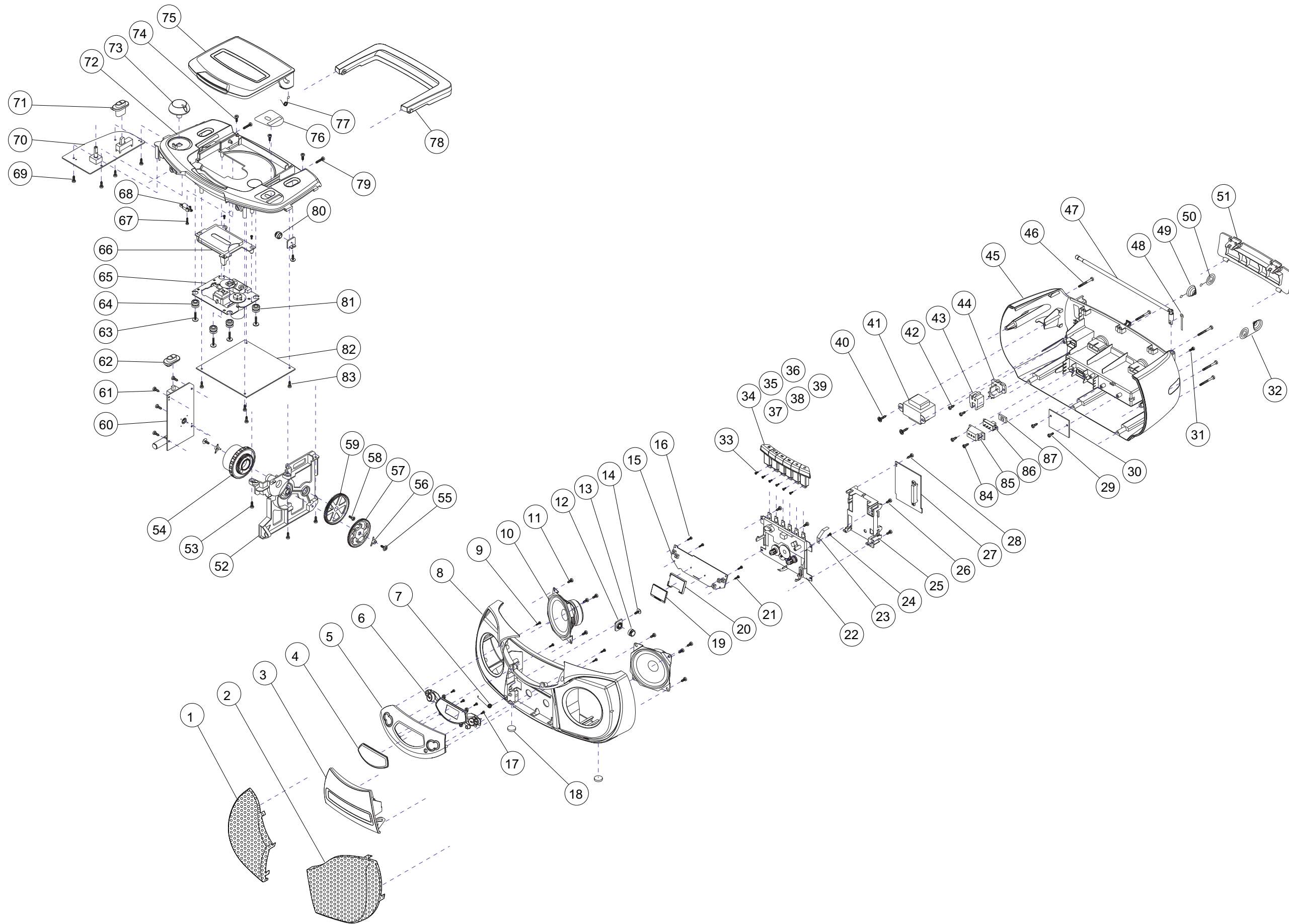

MECHANICAL PARTSLIST

3	9965 000 17747	CASSETTE DOOR
6	9965 000 17759	FUNCTION KNOB-CD
7	3140 111 01220	CASS. DOOR SPRING
8	9965 000 17745	FRONT PANEL ASSY
13	9965 000 17757	CASS DOOR DAMPING GEAR ASSY
20	9965 000 17763	BRACKET-LCD
22	9965 000 16885	CASS. DECK : TK20FX-V682-001
23	3140 111 20800	SPRING-RECORDING
25	3140 114 20430	BRACKET ECO-MTF-SD
32	3140 111 01280	BATTERY CONTACT (+,-)
34	9965 000 17754	CASS BUTTON (PAUSE)
35	9965 000 17753	CASS BUTTON (STOP)
36	9965 000 17751	CASS BUTTON (F.F)
37	9965 000 17752	CASS BUTTON (REW)
38	9965 000 17750	CASS BUTTON (PLAY)
39	9965 000 17749	CASS BUTTON (REC)
45	9965 000 17741	REAR CABINET
47	3140 118 71920	TELESCOPIC AERIAL
49	3140 111 01270	BATTERY CONTACT SPRING (-)
50	3140 111 22110	BATTERY CONTACT SPRING (+)
51	9965 000 17746	BATTERY DOOR
54	9965 000 17748	TUNING KNOB
57	9965 000 17761	TUNING GEAR
59	9965 000 17762	PVC GEAR
62	9965 000 17760	FUNCTION KNOB-BAND
64	9965 000 17765	CD DAMPER 30 DEG
65	9965 000 17245	CD MECHANISM TCP11TM2
66	9965 000 17755	DUST COVER
72	9965 000 17743	TOP CD CABINET
73	9965 000 17758	VOLUME KNOB
75	9965 000 17742	CD DOOR
77	9965 000 17764	CD DOOR SPRING
78	9965 000 17744	HANDLE
80	9965 000 17756	CD DOOR DAMPING GEAR ASSY
81	4822 529 10387	CD DAMPER (40 DEG)
	9965 000 17766	INSTRUCTION SHEET AZ1004/01

ELECTRICAL PARTSLIST**CD / CONTROL BOARD****- MISCELLANEOUS -**

LCD401	9965 000 17776	LCD DISPLAY 0237 OTR-P1
R456	△ 9965 000 17773	FUSIBLE RES 0.47R 1/2W
SW201	4822 276 13443	TACT SWITCH
SW202	4822 276 13443	TACT SWITCH
SW203	4822 276 13443	TACT SWITCH

SW204	4822 276 13443	TACT SWITCH
SW205	4822 276 13443	TACT SWITCH
	9965 000 17774	FFC 16P 140MM
	9965 000 17775	CD DOOR SWITCH

- COILS AND FILTERS -

L401	9965 000 17770	CHOKO COIL 10UH
X401	9965 000 16781	CER.RES CRA16.93M

- DIODES -

D414	9965 000 17767	ZENER DIODE 9V1 1/2W
------	----------------	----------------------

- IC & TRANSISTORS -

IC401	9965 000 17768	IC LA9242M
IC402	9965 000 17769	IC LC78601RE-8615D
IC403	4822 209 15786	LA6541D
Q401	9965 000 17771	TRANS 2SA608NG
Q402	4822 130 42615	BC817-40
Q405	9965 000 17772	TRANS 2SB764E-SSH
Q406	5322 130 60123	BC807-40
Q407	4822 130 42615	BC817-40
Q408	5322 130 60123	BC807-40
Q413	5322 130 41843	2SC2655Y

TUNER BOARD**- MISCELLANEOUS -**

SW301	9965 000 17784	SLIDE SWITCH 4P2T
VC301	9965 000 17787	AM/FM PVC
	9965 000 17271	ANTENNA BAR 5X13X55

- COILS AND FILTERS -

F301	9965 000 17777	AM CER. FILTER SFU468B
F302	9965 000 17778	FM CER. FILTER LT10.7MJ
F303	9965 000 17779	FM CER. FILTER JT10.7MG
L301	9965 000 17781	MW ANT. COIL 93:30T
L302	9965 000 17782	FM COIL 4-1/2T

L303	9965 000 17782	FM COIL 4-1/2T
L304	9965 000 17783	BOBBIN COIL 3-1/2T
T301	9965 000 17785	MW OSC COIL
T302	9965 000 17786	AM IFT YELLOW

- IC & TRANSISTORS -

IC301	9965 000 17780	TA2111N
-------	----------------	---------

RECORDER BOARD**- MISCELLANEOUS -**

1707	4822 277 11504	PUSH SWITCH 6P2T
5701	4822 157 10371	BIAS OSC COIL

- DIODES -

6704	4822 130 30621	1N4148
------	----------------	--------

- IC & TRANSISTORS -

7702	4822 130 40981	BC337-25
7705	4822 209 17498	AN7323

ELECTRICAL PARTSLIST**POWER BOARD****- MISCELLANEOUS -**

R611	△ 9965 000 17788	FUSIBLE RES 4.7R 1/2W
SW601	9965 000 17789	SLIDE SWITCH 6P3T
VR601	9965 000 17790	ROTARY VOLUME B50K

- DIODES -

D601	4822 130 34278	BZX79-B6V8
D602	4822 130 30621	1N4148
D603	4822 130 30621	1N4148
D604	4822 130 30621	1N4148
D605	4822 130 30621	1N4148

D606	4822 130 34173	BZX79-C5V6
D607	4822 130 30621	1N4148
D609	4822 130 30621	1N4148

- IC & TRANSISTORS -

IC601	5322 209 83002	TDA2822M
Q601	9965 000 16928	KTC-8050C
Q602	4822 130 41306	2SC1815GR
Q603	4822 130 41306	2SC1815GR
Q604	9965 000 11826	KSA928AY

Q605	9965 000 16929	KTC-9015C
Q606	9965 000 16927	KTC-9014C

RECTIFIER BOARD**- MISCELLANEOUS -**

F801	△ 4822 070 31252	FUSE 1.25A
------	------------------	------------

- DIODES -

D801	4822 130 31878	1N4003G
D802	4822 130 31878	1N4003G
D803	4822 130 31878	1N4003G
D804	4822 130 31878	1N4003G

OTHERS**- MISCELLANEOUS -**

△ 2422 030 00333	AC SOCKET
△ 3140 118 33580	TRANSFORMER 120/230V
△ 2422 070 98151	MAINS CORD EUR /00C
△ 9965 000 17792	VOLTAGE SELECTOR

9965 000 17791	SPEAKER 3" 8 OHM 2W
----------------	---------------------

Note : Only these parts mentioned in the list are normal service parts.