

Service  
Service  
Service

Manual #1859  
AZ12021701



# Service Manual



CONTENTS	PAGE
Safety	1
Connections and Controls	2-6
Specifications	7
Disassembly Instructions	8
Block Diagram	9
Wiring Diagram	10
Front Board - Circuit Diagram	11
- Layout Diagram	12
Tuner Board (FM/AM) - Circuit Diagram	13
- Layout Diagram	14
Tuner Board (FM/LW/MW) - Circuit Diagram	15
- Layout Diagram	16
Audio Board - Circuit Diagram	17
- Layout Diagram	18
Tape Deck Board - Circuit Board	19
- Layout Board	20
Incredible Sound Board - Circuit Diagram	20
- Layout Diagram	20
Cassette Adjustment	20
CD 97 - Circuit Diagram	21
- Layout Diagram	22
CD Startup and Service Test Program	23-24
Exploded View Diagram - Tape Deck	25
Mechanical Partslist	25
Exploded View Diagram - Cabinet	26
Electrical Partslist	27-31

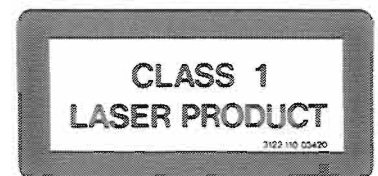

# HANDLING CHIP COMPONENTS

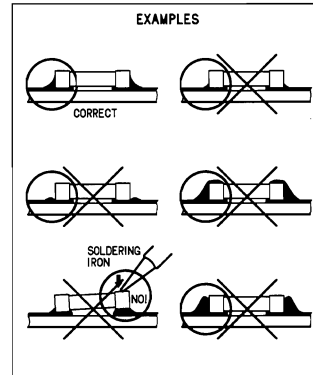
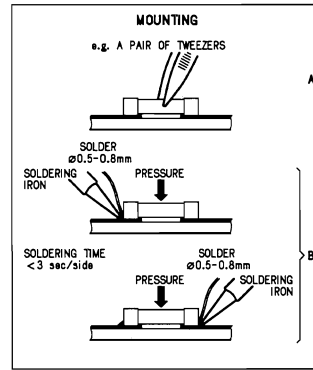
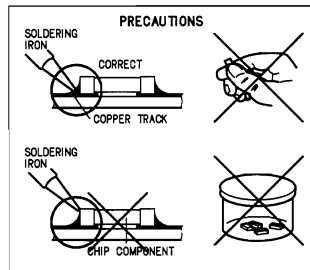
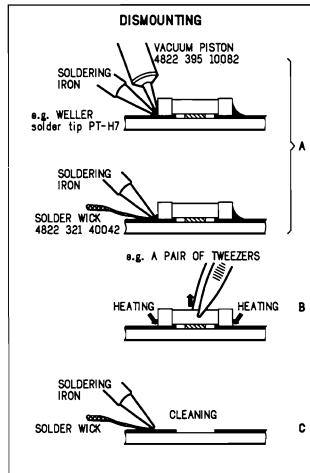
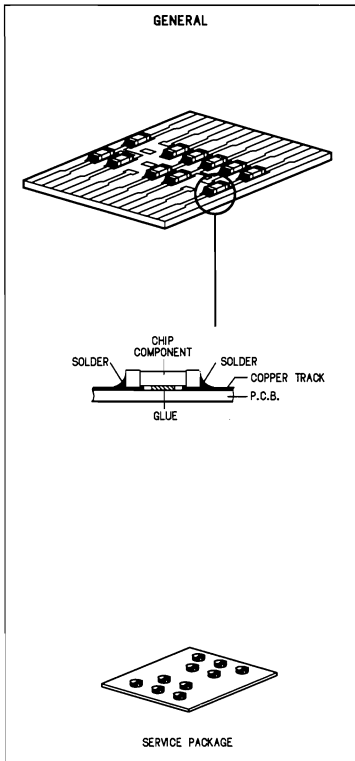

**GB WARNING**

All ICs and many other semiconductors are susceptible to electrostatic discharges (ESD). Careless handling during repair can reduce life drastically. When repairing, make sure that you are connected with the same potential as the mass of the set via a wrist wrap with resistance. Keep components and tools at this potential.

**F ATTENTION**

Tous les IC et beaucoup d'autres semi-conducteurs sont sensibles aux décharges statiques (ESD). Leur longévité pourrait être considérablement écourtée par le fait qu'aucune précaution n'est prise à leur manipulation. Lors de réparations, s'assurer de bien être relié au même potentiel que la masse de l'appareil et enfilez le bracelet serti d'une résistance de sécurité. Veiller à ce que les composants ainsi que les outils que l'on utilise soient également à ce potentiel.

**ESD**



**D WARNUNG**

Alle ICs und viele andere Halbleiter sind empfindlich gegenüber elektrostatischen Entladungen (ESD). Unsorgfältige Behandlung im Reparaturfall kann die Lebensdauer drastisch reduzieren. Sorgen Sie dafür, daß sie im Reparaturfall über ein Pulsarmband mit Widerstand mit dem Massepotential des Gerätes verbunden sind. Halten Sie Bauteile und Hilfsmittel ebenfalls auf diesem Potential.

**NL WAARSCHUWING**

Alle IC's en vele andere halfgeleiders zijn gevoelig voor electrostatische ontladingen (ESD). Onzorgvuldig behandelen tijdens reparatie kan de levensduur drastisch doen verminderen. Zorg ervoor dat u tijdens reparatie via een polsband met weerstand verbonden bent met hetzelfde potentiaal als de massa van het apparaat. Houd componenten en hulpmiddelen ook op ditzelfde potentiaal.

**I AVVERTIMENTO**

Tutti IC e parecchi semi-conduttori sono sensibili alle scariche statiche (ESD). La loro longevità potrebbe essere fortemente ridotta in caso di non osservazione della più grande cauzione alla loro manipolazione. Durante le riparazioni occorre quindi essere collegato allo stesso potenziale che quello della massa dell'apparecchio tramite un braccialetto a resistenza. Assicursarsi che i componenti e anche gli utensili con quali si lavora siano anche a questo potenziale.

Anti-static table mat large 1200x650x1.25mm  
small 600x650x1.25mm

Anti-static wrist band  
Connection box (1MΩ)  
Extendible cable (to connect wrist band to conn. box)  
Connecting cable (to connect table mat to conn. box)  
Earth cable (to connect any product to mat or box)  
Complete kit ESD3 (combining all above products)  
Wristband tester

4822 466 10953  
4822 466 10958  
4822 395 10223  
4822 320 11307  
4822 320 11305  
4822 320 11306  
4822 320 11308  
4822 310 10671  
4822 344 13999

**GB**

Safety regulations require that the set be restored to its original condition and that parts which are identical with those specified be used. Safety components are marked by those symbol. ▲

**S Varning !**

Osynlig laserstrålning när apparaten är öppnad och spårren är urkopplad. Betrakta ej strålen.

**DK Advarsel !**

Usynlig laserstrålning ved åbning når sikkerhedsafbrudt er ude af funktion. Undgå udsættelse for stråling.

**SF Varoitus !**

Avätussa laitteessa ja suojalukituksen ohitettaessa olet alttiina näkymättömälle laserisäteilylle. Älä katso säteeseen!

**GB WARNING**

Safety regulations require that the set be restored to its original condition and that parts which are identical with those specified be used.

**F ATTENTION**

Les normes de sécurité exigent que l'appareil soit remis à l'état d'origine et que soient utilisées les pièces de rechange identiques à celles spécifiées.

**D WARNUNG**

Bei jeder Reparatur sind die geltenden Sicherheitsvorschriften zu beachten. Der Originalzustand des Gerätes darf nicht verändert werden. Für Reparaturen sind Original-ersatzteile zu verwenden.

**NL WAARSCHUWING**

Veiligheidsbepalingen vereisen, dat het apparaat in zijn oorspronkelijke toestand wordt teruggebracht en dat onderdelen, identiek aan de gespecificeerde, worden toegepast.

**I AVVERTIMENTO**

Le norme di sicurezza estigono che l'apparecchio venga rimesso nelle condizioni originali e che siano utilizzati i pezzi di ricambio identici a quelli specificati.

# CONNECTIONS AND CONTROLS

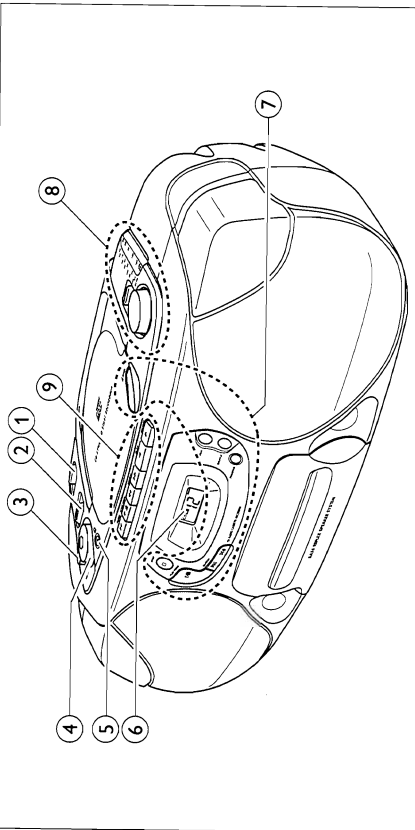

## BASIC FUNCTIONS

- ① POWER:
  - CD, TUNER, TAPE...selects the sound source
- ② INCREDIBLE SURROUND .....creates a phenomenal stereo effect
- ③ DBB.....enhances the bass
- ④ VOLUME .....adjusts the volume level
- ⑤ f .....3.5mm headphones socket  
*Note: Connecting the headphones will switch off the speakers.*
- ⑥ Display
- ⑦ CD PLAYER
  - △ OPEN .....opens the CD compartment
  - STOP □ .....stops CD play and erases the program
  - PLAY-PAUSE ▷|||.....starts and interrupts CD play
  - SEARCH ◀◀ .....skips and searches forward and backward
- PROGRAM .....programs track numbers and reviews the program
- SHUFFLE .....plays CD tracks in random order
- REPEAT .....repeats a track, the entire CD, or the program
- ⑧ RADIO
  - TUNING .....tunes to radio stations
  - BAND .....selects the wave band
- ⑨ CASSETTE RECORDER
  - PAUSE ||| .....interrupts recording or playback
  - STOP-OPEN □△ .....stops the tape and opens the cassette compartment
  - SEARCH ▷> .....rewinds the tape
  - SEARCH ◀< .....fast forwards the tape
  - PLAY ◀ .....starts playback
  - RECORD ○ .....starts recording

## Batteries

### For the set (optional)

Open the battery compartment of the set and insert 6 batteries, type R20, UM-1 or D-cells (preferably alkaline).

Remove batteries if they are flat or the set is not going to be used for a longer period of time.

**Batteries contain chemical substances, so they should be disposed of properly.**

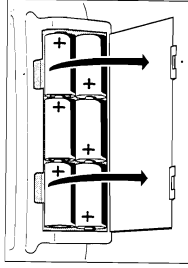

## Mains

1 Check whether the mains voltage as shown on the type plate corresponds to your local mains voltage. If it does not, consult your dealer or service organisation. **The type plate is located on the bottom side of the set.**

2 If the set is equipped with a VOLTAGE selector (X), set this selector to the local mains voltage.

3 Connect the mains cable to the AC MAINS inlet and the wall socket. This switches on the mains supply. **The mains cable is inside the battery compartment.**

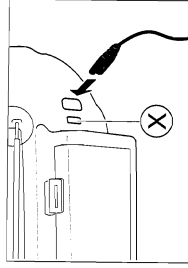

The battery supply will be switched off when the set is connected to the mains. To change over to battery supply, pull out the plug from the unit's AC MAINS socket.

To disconnect the set from the mains completely, remove the mains plug from the wall socket.

*For users in the U.K.: please follow the instructions on page 2.*

## Environmental information

All redundant packing material has been omitted. We have done our utmost to make the packaging easily separable into three mono materials: cardboard (box), polystyrene foam (buffer) and polyethylene (bags, protective foam sheet).

*Your set consists of materials which can be recycled if disassembled by a specialized company. Please observe the local regulations regarding the disposal of packing materials, exhausted batteries and old equipment.*

# CONNECTIONS AND CONTROLS

## Switching on and off

Set the POWER slider to the desired sound source: CD, TUNER, or TAPE.

The set is switched off when the POWER slider is in position OFF/TAPE and the keys of the tape deck are released.

*Note: If you run the set on batteries, always be sure to switch the set off after use. This will avoid unnecessary power consumption.*

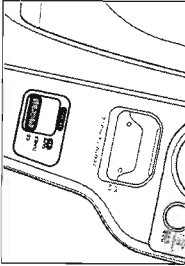

## Adjusting volume and sound

Adjust the volume using the VOLUME  $\nabla$   $\triangle$  control.

Increase and decrease the bass level by pressing DBB.

Switch the surround sound effect on and off by pressing INCREDIBLE SURROUND.

The bass level can also be emphasised if you place the set against a wall or shelf. Do not cover any vents and leave sufficient room around the unit for ventilation.

*Note: The effect of INCREDIBLE SURROUND may vary with different types of music.*

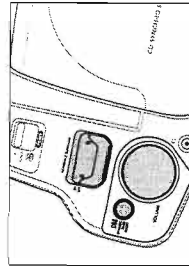

## Radio – tuning to radio stations

1 Set the POWER slider to TUNER.

2 Select the wave band by using the BAND selector.

3 Tune to the desired radio station by using the TUNING knob.

## Improving RADIO reception

For FM stations, pull out the telescopic antenna. To improve the signal, incline and turn the antenna. Reduce its length if the signal is too strong (very close to a transmitter).

For MW and LW stations, direct the built-in antenna by turning the whole set. The telescopic antenna is not needed.

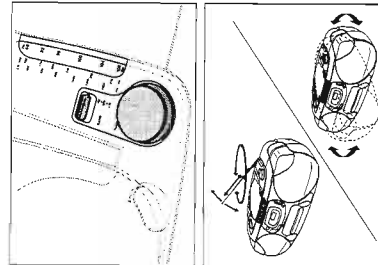

## Playing a CD

1 Set the POWER slider to CD.

2 Press  $\triangle$  OPEN to open the CD compartment.

3 Insert an audio CD (printed side up) and close the CD compartment.

→ The CD player starts and scans the contents list of the CD. Then, the CD player stops. Display indication: the total number of tracks.

4 Press the PLAY/PAUSE  $\triangleright$  button to start CD play.

→ Display indication: the current track number.

5 Press the STOP  $\square$  button to stop CD play.

→ Display indication: the total number of tracks.

You can interrupt CD play by pressing PLAY/PAUSE  $\triangleright$ . Continue CD play by pressing the button again.

→ Display indication: the current track number flashes.

*Note: CD play will also stop if:*

- you open the CD compartment,
- the end of the CD is reached, or
- you move the POWER slider to TUNER or TAPE.

If you make a mistake when operating the CD player, or the CD player cannot read the CD, the display shows  $E$  or  $no$ . (See chapter "TROUBLESHOOTING".)

If you press PLAY/PAUSE  $\triangleright$  and there is no CD inserted the display shows  $no$ .

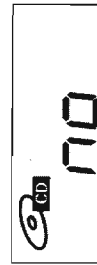
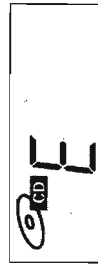
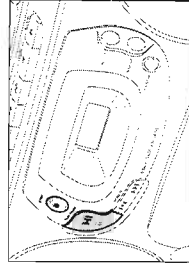
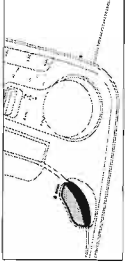

# CONNECTIONS AND CONTROLS

## Different playing modes: SHUFFLE / REPEAT

### SHUFFLE – Playing in random order

- 1 Press SHUFFLE before or during CD play.  
→ All the tracks of the CD (or program if available) will now be played in random order.

- 2 Press SHUFFLE again to return to normal CD play.

### REPEAT – Repeating the entire CD or one track of the CD

- 1 Before or during CD play, press REPEAT repeatedly to cause the display to show the different repeating modes.  
→ **REPEAT**: the current track is played repeatedly.  
→ **REPEAT ALL**: the entire CD or program is played repeatedly.

- 2 Press REPEAT until the display indication disappears to return to normal CD play.

*Note: You can activate the different playing modes at the same time, e. g. you can repeatedly play the entire CD or program in random order (SHUFFLE REPEAT ALL).*

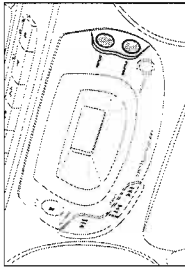

## Search backward and forward

### Selecting another track

Briefly press the SEARCH  $\llcorner$  or  $\triangleright$  button once/several times to skip to the beginning of the current/previous or subsequent track(s).

#### During play:

CD play continues automatically with the selected track.  
When CD playback is stopped:

Press PLAY/PAUSE  $\triangleright$  to start CD play.

- Display indication: the selected track number.

### Searching for a passage during CD play

- 1 Hold down the SEARCH  $\llcorner$  or  $\triangleright$  button to find a particular passage in a forward or backward direction.  
→ CD play continues at a low volume.

- 2 Release the button when you have reached the desired passage.

*Note: In the SHUFFLE and REPEAT modes or when playing a program, searching is only possible within the particular track.*

## Programming track numbers

You can select a number of tracks and store these in the memory in the desired sequence. You can store any track more than once. A maximum of 20 tracks can be stored in the memory.

- 1 Select the desired track with SEARCH  $\llcorner$  or  $\triangleright$ .
- 2 As soon as the number of the desired track is displayed, press the PROGRAM button to store the track in the memory.  
→ **PROGRAM** appears in the display and  $P$  lights up briefly. Then, the number of the stored track is shown.
- 3 Select and store all desired tracks in this way.

You can review your settings by pressing the PROGRAM button for more than 2 seconds.

- The display shows all stored track numbers in sequence.

If you try to store more than 20 tracks the display shows  $F$ .

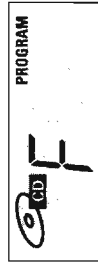
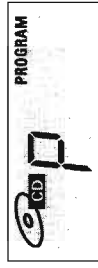
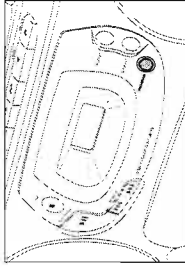

## Playing the program

If you have selected the tracks in the stop position, press PLAY/PAUSE  $\triangleright$ .

If you have selected the tracks during CD play, first press STOP  $\square$ , then press PLAY/PAUSE  $\triangleright$ .

## Erasing the program when CD playback is stopped

From the stop position, press STOP  $\square$ .

- $P$  lights up briefly, **PROGRAM** disappears and your program is erased.

*Note: The program will also be erased if you*

- interrupt the power supply,
- open the CD compartment, or
- move the POWER slider to TUNER or TAPE.

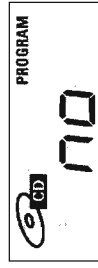

# CONNECTIONS AND CONTROLS

## Playing a cassette

- 1 Set the POWER slider to TAPE.
- 2 Press STOP-OPEN  $\square \blacktriangle$  to open the cassette compartment.
- 3 Insert a recorded cassette with the open side upwards and close the cassette compartment.
- 4 Press PLAY  $\blacktriangleleft$  to start playback.
- 5 Press  $\Rightarrow$  or  $\Leftarrow$  to rewind or fast forward the tape.
- 6 To stop the tape press STOP-OPEN  $\square \blacktriangle$ .

*Note: The keys are released at the end of the tape.*

## General information on recording

Recording is permissible insofar as copyright or other rights of third parties are not infringed upon.

For recording on this set you should use a cassette of the type NORMAL (IEC type I). This deck is not suitable for recording on cassettes of the type CHROME (IEC type II) or METAL (IEC type IV).

The recording level is set automatically. The controls VOLUME, INCREDIBLE SURROUND and DBB do not affect the recording.

At the very beginning and end of the tape, no recording will take place in the 7 seconds during which the leader tape passes the recorder heads.

## Protecting tapes from accidental erasure

Keep the cassette side to be protected in front of you and snap off the left tab. Now, recording on this side is no longer possible.

To record again on this side of the cassette, cover the aperture with a piece of adhesive tape.

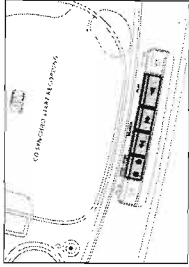

## Recording from the CD player – CD synchro start

- 1 Set the POWER slider to CD.
- 2 Insert a CD and, if desired, program track numbers.
- 3 Press STOP-OPEN  $\square \blacktriangle$  to open the cassette compartment.
- 4 Insert a blank, unprotected cassette and close the cassette compartment.
- 5 Press RECORD  $\circ$  to start recording.  
→ Playing of the CD or program starts automatically. It is not necessary to start the CD player separately.
- 6 For brief interruptions press PAUSE  $\square \square$ . Press the PAUSE  $\square \square$  key again to resume recording.
- 7 To stop recording, press STOP-OPEN  $\square \blacktriangle$ .

*Note: the recording can be started from different positions:*

- if the CD player is in pause mode, recording will start from this very position (use SEARCH  $\Leftarrow$  or  $\Rightarrow$ );
- if the CD player is in stop mode, recording will start from the beginning of the CD or program.

## Recording from the radio

- 1 Set the POWER slider to TUNER.
- 2 Tune to the desired radio station (see chapter "RADIO").
- 3 Press STOP-OPEN  $\square \blacktriangle$  to open the cassette compartment.
- 4 Insert a blank, unprotected cassette and close the cassette compartment.
- 5 Press RECORD  $\circ$  to start recording.
- 6 For brief interruptions press PAUSE  $\square \square$ . To resume recording press the PAUSE  $\square \square$  key again.
- 7 To stop recording, press STOP-OPEN  $\square \blacktriangle$ .

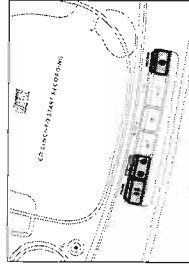
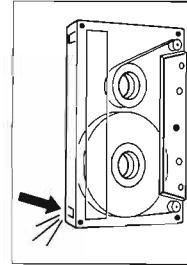

# CONNECTIONS AND CONTROLS

## WARNING

If a fault occurs, first check the points listed below before taking the set for repair.

**Under no circumstance should you try to repair the set yourself as this will invalidate the guarantee.**

**General maintenance**

Do not expose the set, batteries, CDs or tapes to humidity, rain, sand or excessive heat (caused by heating equipment or direct sunlight).

The mechanical parts of the set contain self-lubricating bearings and must not be oiled or lubricated!

You can clean the set with a soft, slightly dampened lint-free cloth. Do not use any cleaning agents as they may have a corrosive effect.

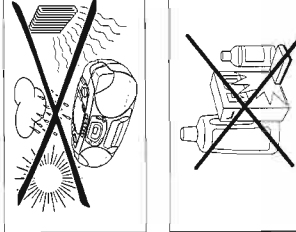

## Tape deck maintenance

To ensure proper recording and playback quality, clean the parts (A), (B) and (C) after approx. 50 hours of operation. Use a cotton swab slightly moistened with alcohol or head-cleaner fluid.

Press PLAY < and clean the rubber pressure rollers (C).

Press PAUSE III and clean the capstans (B) and the heads (A).

*Note: Cleaning of the heads (A) can also be done by playing a cleaning tape once.*

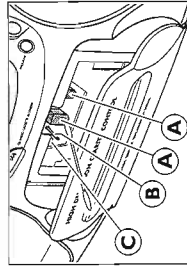

## CD player and CD handling

The lens (X) of the CD player should never be touched. Always keep the CD compartment closed to avoid dust on the lens.

The lens may cloud over when the set is suddenly moved from cold to warm surroundings. Playing a CD is not possible then. Leave the CD player in a warm environment until the moisture evaporates.

To take the CD out of its box easily, press the centre spindle while lifting the CD. Always pick up the CD by the edge and put it back in its box after use.

To clean the CD, wipe it in a straight line from the center toward the edge using a soft, lint-free cloth. A cleaning agent may damage the disc!

Never write on a CD or attach a sticker to it.

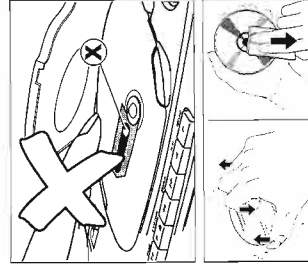

**This set complies with the radio interference requirements of the European Community**

Problem	Possible cause	Solution
No sound, no power	VOLUME is not adjusted. Headphone is connected. Mains cable is not securely connected. Batteries are flat.	Adjust volume. Disconnect headphone. Connect mains cable properly. Insert fresh batteries.
No reaction to operation of any keys	Batteries are inserted incorrectly. Trying to change over from mains to battery supply without removing the plug.	Insert batteries correctly. Remove the mains plug from the unit's AC MAINS inlet.
Poor radio reception	Electrostatic discharge. Weak radio signal.	Disconnect the set from power supply, reconnect after a few seconds. Direct the antenna for optimum reception.
r, o or E indication	Interference caused by vicinity of electrical equipment like TVs, computers, engines, etc... The CD is badly scratched or dirty.	Keep the radio away from electrical equipment. Replace or clean the CD.
The CD skips tracks	No CD is inserted. The CD is inserted upside down. The laser lens is steamed up. The CD is damaged or dirty.	Insert a CD. Insert CD with label upwards. Wait until the lens has cleared. Replace or clean the CD.
Poor cassette sound quality	SHUFFLE or PROGRAM is active. Dust and dirt on the heads, capstans or pressure rollers. Use of unsuitable cassette types (METAL or CHROME) for recording.	Switch off SHUFFLE or PROGRAM play. Clean heads, capstans, and pressure rollers. Only use NORMAL type cassettes for recording.
Recording does not work	Cassette tabs may be snapped off.	Apply a piece of adhesive tape over the aperture.

## SPECIFICATIONS

### GENERAL

Mains voltage	-/00 : 230 V
	-/01/11/11H : 120/230 V
	-/05/10 : 240 V
	-/17 : 120 V
Mains frequency	-/00/05/10 : 50 Hz
	-/01/11/11H : 50/60 Hz
	-/17 : 60 Hz
Battery	: R20 x 6 (9 V)
Power consumption	: 16 W
Dimension (W x H x D)	: 470 x 175 x 250 mm
Weight	: 4.5 Kg

### AMPLIFIER

Output power	mains : 2 x 1.6 W
	battery : 2 x 1.6 W
Speaker impedance	: 2 x 4 $\Omega$
Frequency response	: 100 Hz - 100 kHz

### TUNER - FM SECTION

Tuning range	: 87.5 - 108 MHz
IF frequency	: 10.7 MHz $\pm$ 0.2 MHz
Sensitivity	: < 22 dBf at 26 dB S/N
Selectivity	: < 20 dB at 1kHz $\pm$ 300 kHz
IF rejection	: < 50 dB
Image rejection	: < 20 dB

### TUNER - AM SECTION

Tuning range	MW : 522 - 1611 kHz
Tuning range	LW : 153 - 279 kHz
IF frequency	: 468 kHz $\pm$ 3 kHz
Sensitivity	MW : < 4000 $\mu$ V/m at 26dB S/N
	LW : < 6000 $\mu$ V/m at 26dB S/N
Selectivity	MW : < 16 dB
	LW : < 20 dB
IF rejection ratio	MW : < 24 dB
	LW : < 26 dB
Image rejection ratio	MW : < 28 dB
	LW : < 30 dB

### AUDIO CASSETTE RECORDER

Number of tracks	: 1 stereo
Tape speed	: 4.76 cm/sec $\pm$ 3 %
Wow & flutter	: < 0.48 % JIS UWTD
Fast wind/rewind C60	: < 110 sec
Frequency response	P/B : 125 - 6300 Hz
S/N ratio	: $\geq$ 38 dB

### COMPACT DISC

Frequency response	: 100 Hz - 10 kHz
S/N ratio	: < 60 dB
Channel difference	1 kHz : < 3 dB
Channel crosstalk	1 kHz : > 15dB
Laser wavelength	: 780 $\pm$ 20 nm
Laser light power	: < 0.3 mW



# DISASSEMBLY DIAGRAM

- A. To remove Front Cabinet Assembly
- B. To remove Cassette Door
- C. To remove Tape Deck
- D. To remove CD Assembly
- E. To remove Audio Board Assembly
- F. To remove Tuner Board
- G. To remove Handle

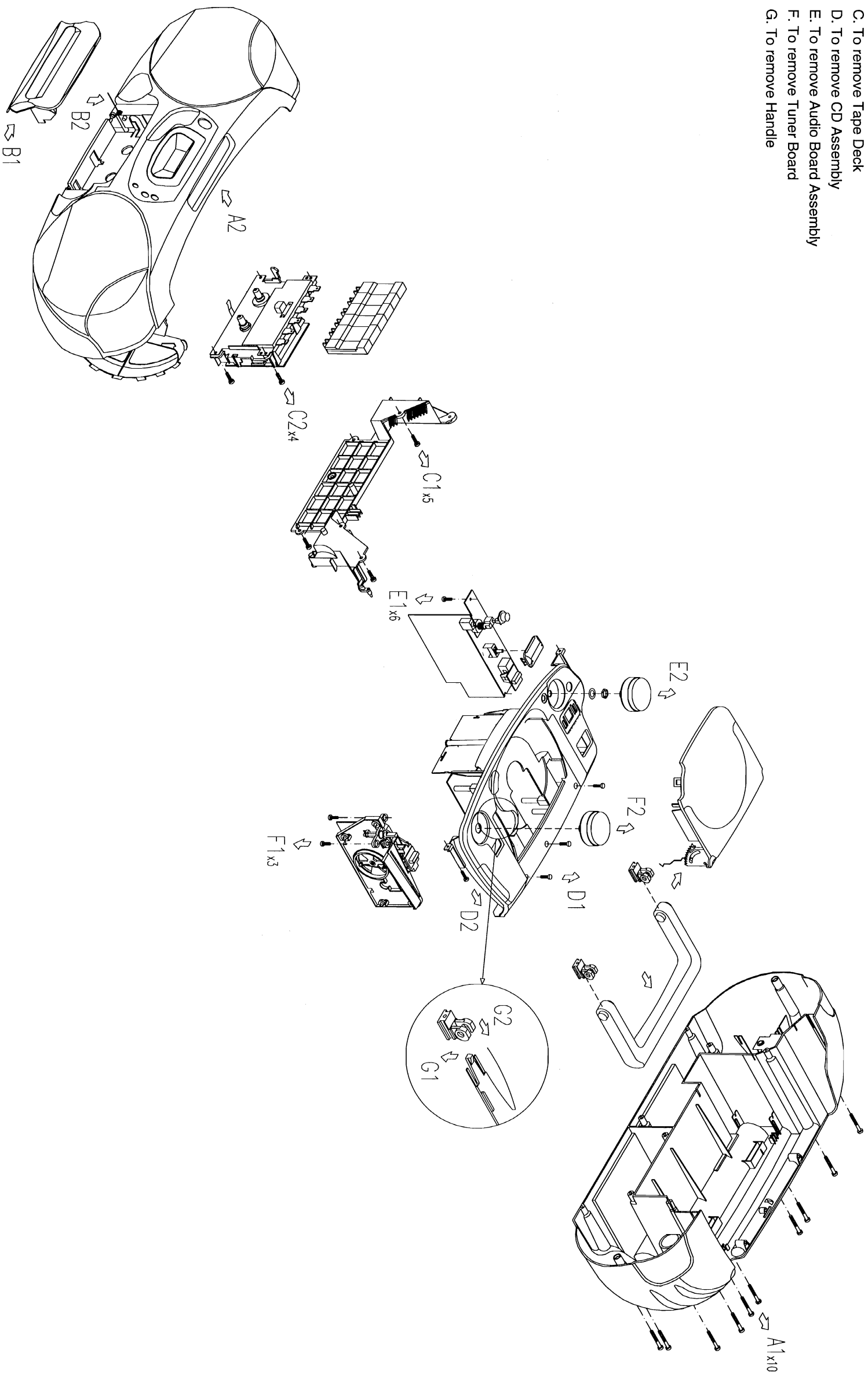

**BLOCK DIAGRAM**

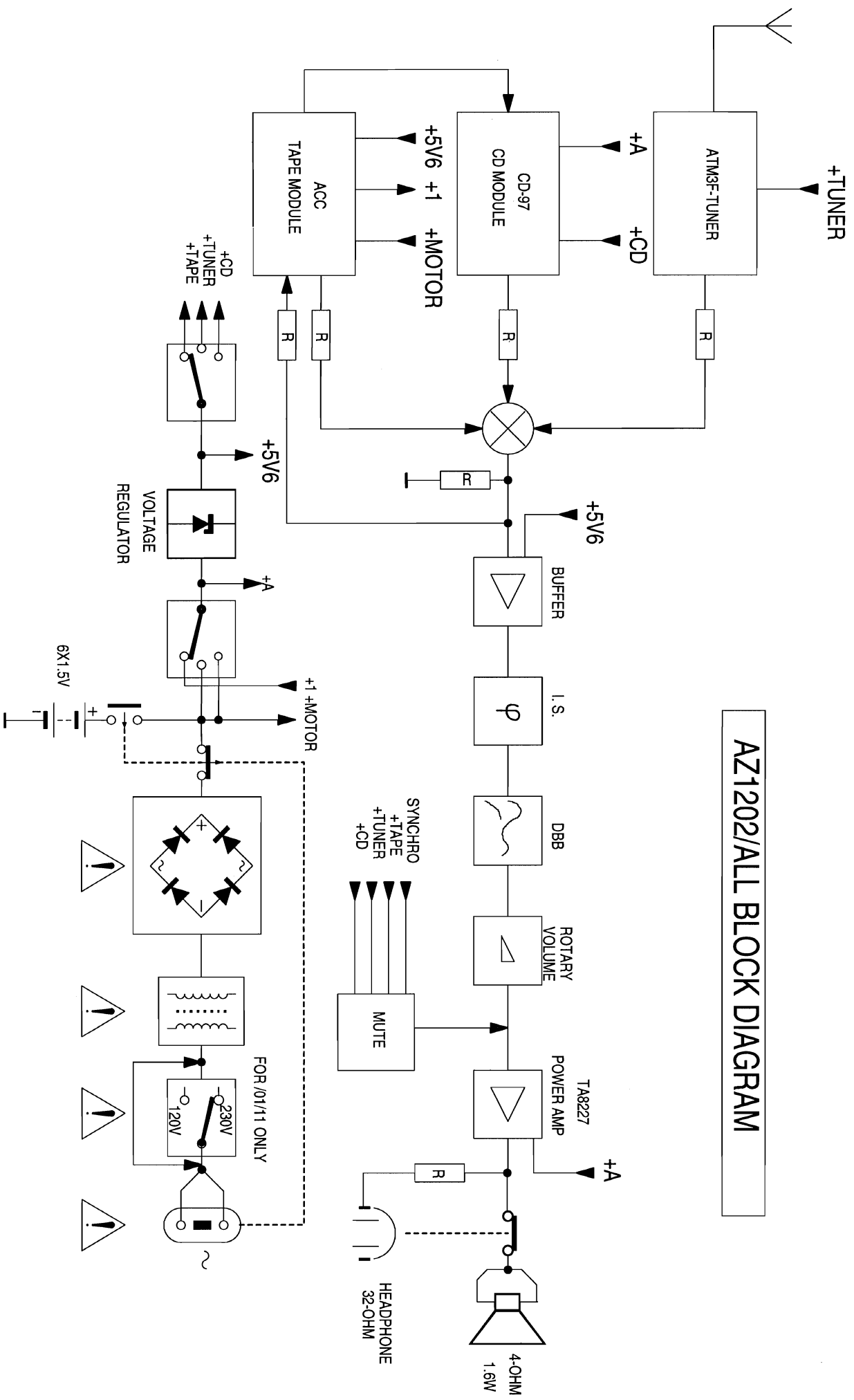

**AZ1202/ALL BLOCK DIAGRAM**

# WIRING DIAGRAM

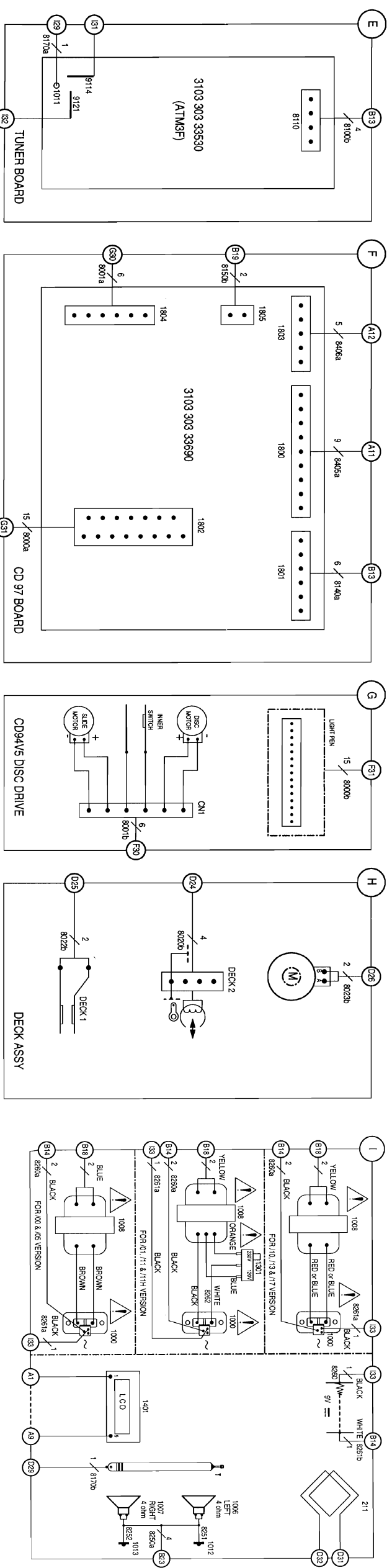
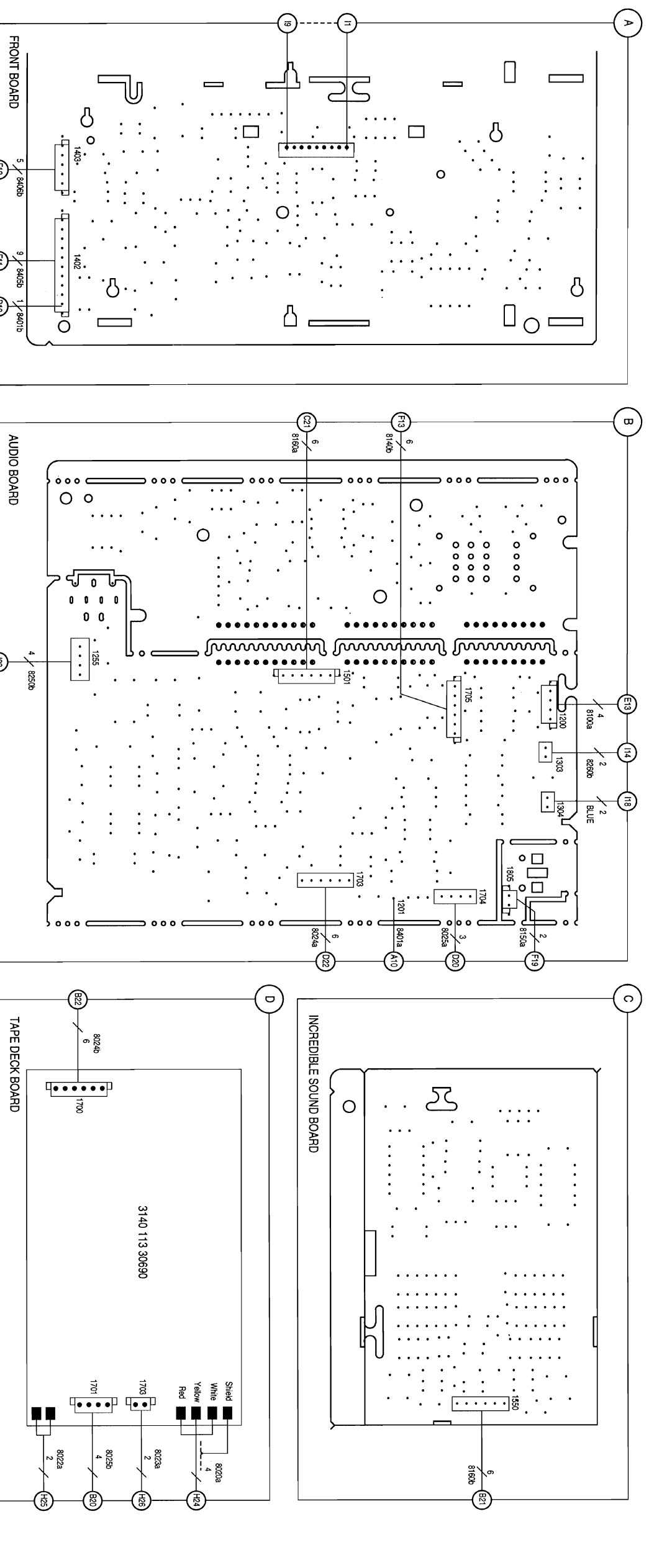

FRONT BOARD - CIRCUIT DIAGRAM

1401	A 3	1411	H 5	1417	I 6	2444	C 14	2478	E 11	3403	C 9	3408	A 11	3415	I 5	3444	I 5	3445	B 6	3458	B 4	3463	B 4	3465	H 4	3468	G 6	3473	G 8	3478	D 10	3483	F 10	3493	C 10	5403	D 9	5404	D 9	7441	C 12	9498	H 13		
1402	G 14	1412	H 5	2401	B 9	2445	D 15	2491	D 12	3404	A 8	3411	H 5	3418	I 6	3445	C 15	3446	C 15	3454	B 5	3459	E 2	3464	H 4	3469	F 8	3475	F 8	3479	D 8	3484	H 4	3485	I 4	5401	C 8	5402	A 9	7401	D 14	7413	D 14	9499	H 13
1403	F 12	1413	H 5	2402	C 8	2446	D 15	2499	E 13	3405	B 8	3412	H 5	3441	C 13	3442	C 13	3443	C 13	3451	B 7	3455	H 3	3461	E 2	3466	E 8	3476	E 8	3481	F 2	3482	E 2	5403	F 2	5405	A 10	5406	C 9	7402	C 9	9496	F 13		
1404	E 12	1414	H 5	2403	C 8	2447	H 4	2491	C 8	3406	B 8	3414	H 5	3442	H 4	3443	C 12	3452	B 4	3453	B 4	3459	H 3	3462	H 3	3467	G 3	3477	E 8	3482	F 2	3492	C 11	5402	C 9	5403	C 9	7403	A 10	9497	F 13				
1410	H 4	1415	I 5	2443	D 12	2465	H 4	3402	C 8	3407	A 10	3414	H 5	3442	H 4	3443	C 12	3452	B 4	3453	B 4	3459	H 3	3462	H 3	3467	G 3	3477	E 8	3482	F 2	3492	C 11	5402	C 9	5403	C 9	7403	A 10	9497	F 13				

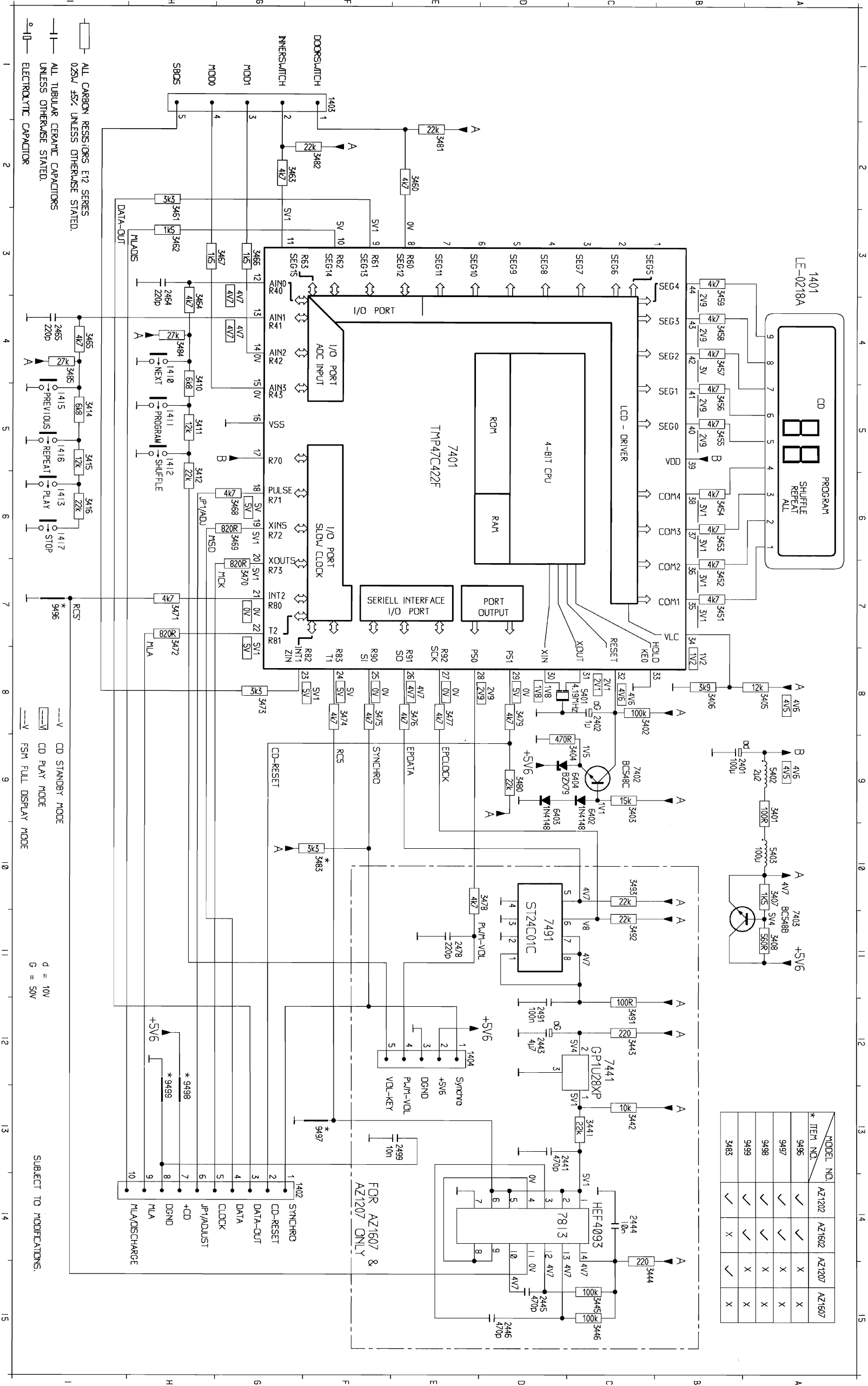

MODEL NO.	AZ1202	AZ1602	AZ1207	AZ1607
9495	✓	✓	X	X
9497	✓	✓	X	X
9498	✓	✓	X	X
9499	✓	✓	X	X
3483	✓	X	✓	X

ALL CARBON RESISTORS E12 SERIES  
 0.25W 5% UNLESS OTHERWISE STATED.  
 ALL TUBULAR CERAMIC CAPACITORS  
 UNLESS OTHERWISE STATED.  
 ELECTROLYTIC CAPACITOR

CD STANDBY MODE  
 CD PLAY MODE  
 FSM FULL DISPLAY MODE

d = 10V  
 G = 50V

SUBJECT TO MODIFICATIONS.

FRONT BOARD - LAYOUT DIAGRAM

1401 A 3	1415 B 1	3401 B 5	3408 A 2	3451 A 3	3458 A 4	3465 A 5	3472 B 4	3482 A 1	8402 A 3	9403 B 2	9412 B 1	9422 B 2	9499 B 1
1402 B 1	1416 A 5	3402 A 3	3410 A 5	3452 A 3	3459 A 4	3466 B 5	3473 B 4	3483 A 1	8403 A 3	9406 B 4	9413 B 1	9423 A 1	
1403 A 1	1417 A 1	3403 A 3	3411 A 5	3453 A 3	3460 A 5	3467 B 5	3474 B 4	3484 A 2	8404 B 2	9407 B 1	9414 B 2	9424 B 2	
1410 B 2	2401 B 5	3404 B 3	3412 A 1	3454 A 3	3461 A 5	3468 B 5	3475 B 4	3485 A 1	7401 A 4	9408 B 1	9417 A 1	9425 B 3	
1411 B 5	2402 B 3	3405 A 3	3414 A 5	3455 A 3	3462 A 5	3469 B 4	3479 B 3	5401 A 3	7402 B 3	9409 B 1	9419 A 1	9496 B 4	
1412 B 5	2464 A 5	3406 A 3	3415 A 1	3456 A 3	3463 A 5	3470 B 4	3480 B 2	5402 B 5	7403 A 2	9410 B 5	9420 A 1	9497 B 4	
1413 B 1	2465 A 5	3407 A 3	3416 A 1	3457 A 4	3464 A 5	3471 B 4	3481 A 1	5403 B 5	9402 A 2	9411 B 1	9421 B 1	9498 B 1	

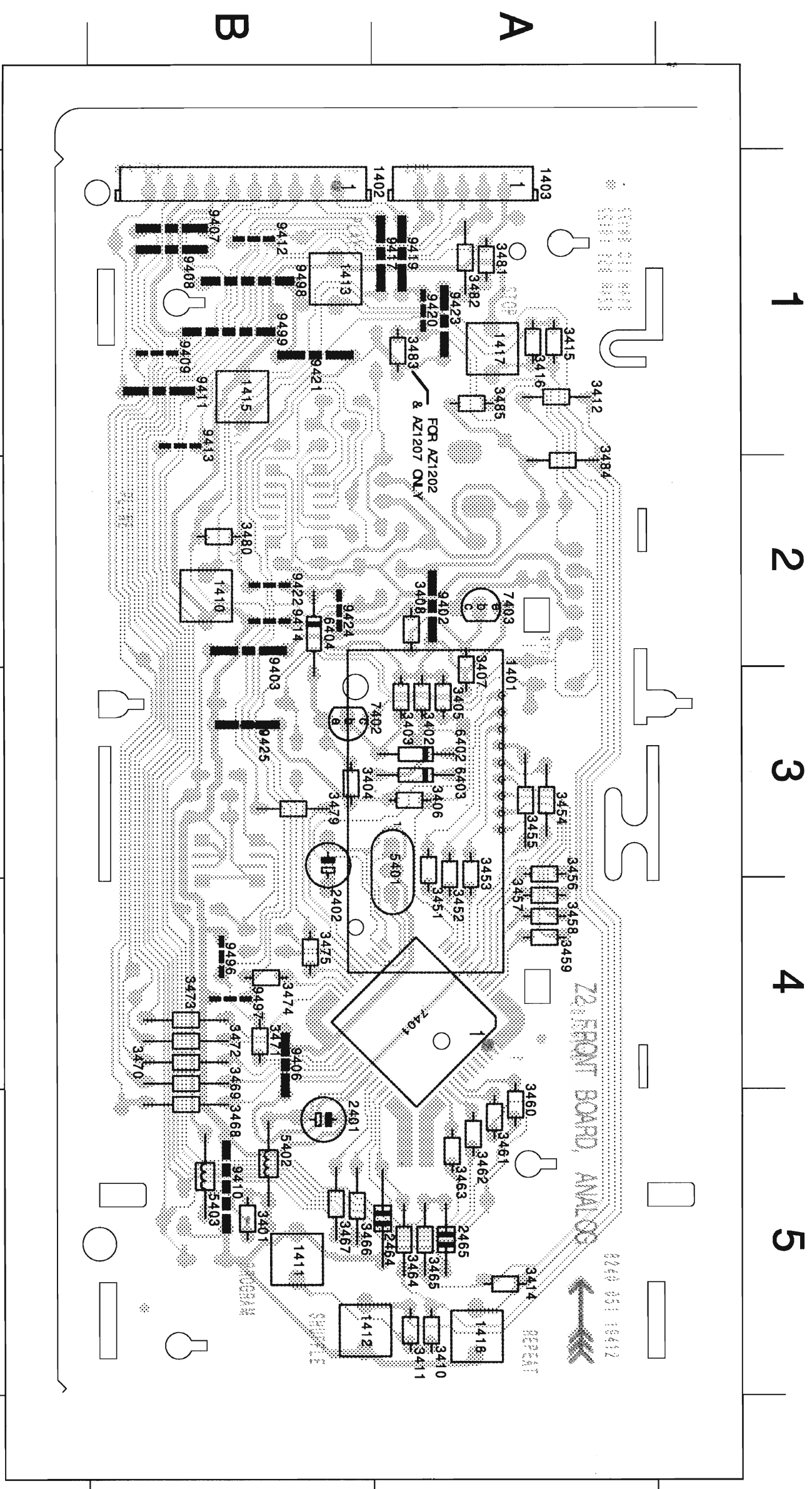

# ANALOG TUNER BOARD (ATM3F)

## FM/MW versions

VERSION	FM	Japan
ITEM. *	87.5-108MHz	76-108 MHz
2105	22p	22p
2106	20p	40p
2107	-	470p
2108	22p	10p
2109	4p7	2p2
5101	550H	600H
5104	400H	800H
9101	JMP	-

U.....provisional only  
 V.....for Japanese version only

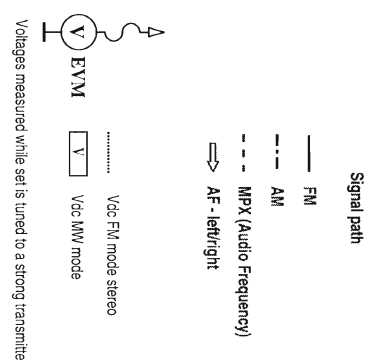
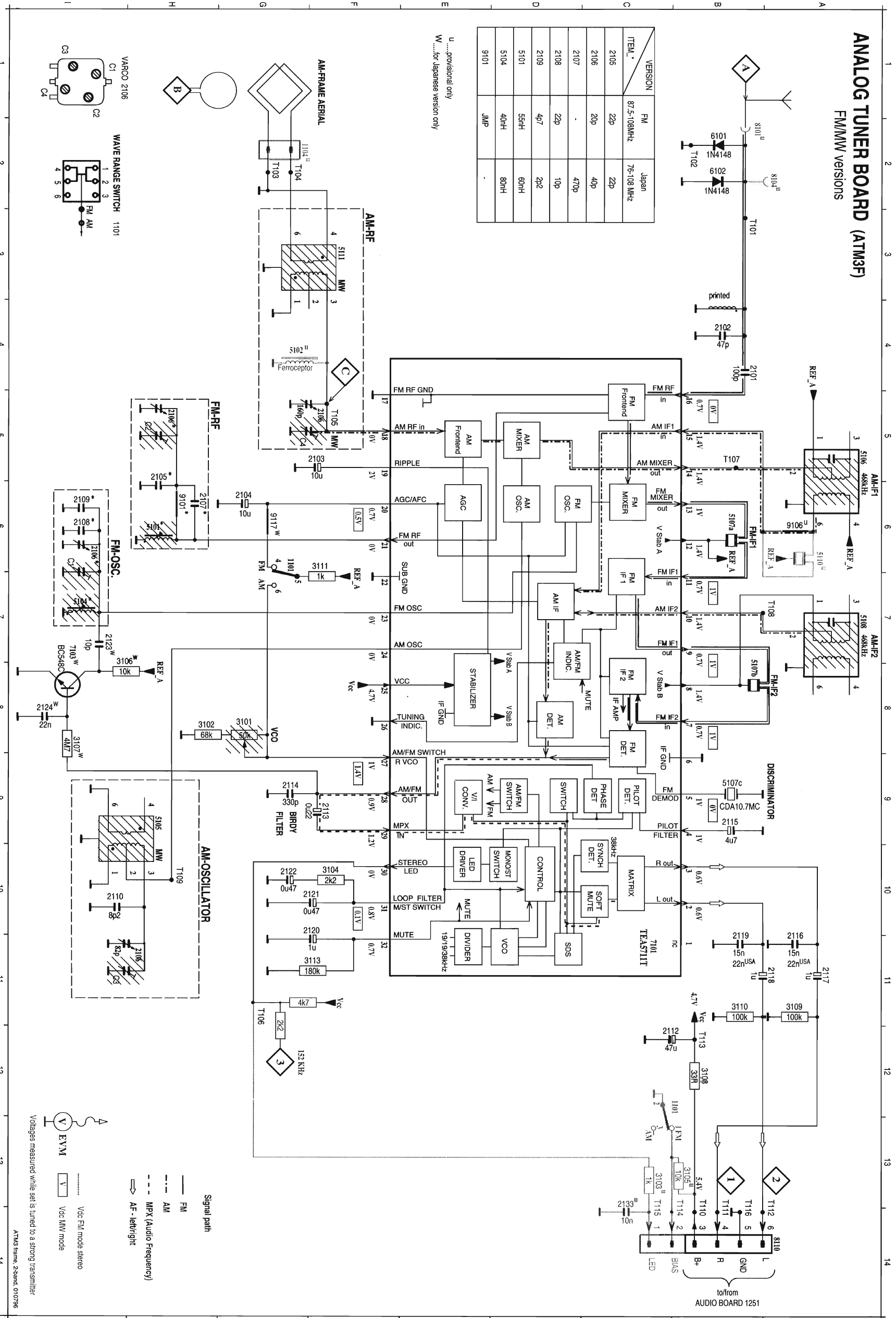

ATM3 Frame, 2band, 010796

- 1101 B12
- 1101 G6
- 1104 G2
- 2101 B4
- 2102 F3
- 2104 G3
- 2105 H5
- 2106 H5
- 2106 H1
- 2106 H5
- 2106 H5
- 2107 H6
- 2108 H6
- 2109 H6
- 2110 H0
- 2112 B12
- 2113 F9
- 2114 G9
- 2115 B9
- 2116 A11
- 2117 A11
- 2118 A11
- 2119 B11
- 2120 F10
- 2121 F10
- 2122 G10
- 2123 G10
- 2124 H8
- 3101 G8
- 3102 H8
- 3103 C13
- 3104 F10
- 3105 B13
- 3106 H8
- 3107 H8
- 3108 B12
- 3109 A11
- 3110 B11
- 3111 F6
- 3113 F11
- 3101 H6
- 3102 G4
- 3104 I7
- 3105 I7
- 3106 A5
- 3107 A5
- 3108 B8
- 3109 B8
- 3110 B8
- 3111 B8
- 3112 B8
- 3113 F3
- 3114 F3
- 3115 F3
- 6101 B2
- 6102 B2
- 7101 C1
- 7103 I7
- 8101 B2
- 8104 A2
- 8104 A2
- 9101 H6
- 9106 A6
- 9117 G6

2101 B 1	2106 A 2	2114 B 4	2121 A 4	2103 A 4	2110 B 4	2106 B 3	2101 B 1	2101 B 3	2116 A 4
2104 A 1	2107 B 3	2115 B 4	2122 A 3	2104 A 4	2113 A 1	2107 B 2	2106 B 2	2107 B 2	2117 A 1
2101 B 2	2108 A 3	2116 A 4	2123 A 3	2105 A 4	2113 B 4	2107 B 4	2108 B 2	2108 B 2	2117 A 1
2102 B 2	2109 A 3	2117 B 4	2124 A 3	2106 A 4	2114 A 3	2108 B 3	2109 B 2	2109 B 2	2118 A 1
2103 B 3	2110 A 2	2118 B 4	2125 A 4	2107 A 4	2115 A 4	2109 B 4	2110 A 1	2110 A 1	2118 A 1
2104 B 2	2112 A 4	2119 B 4	2126 A 4	2108 A 4	2116 A 4	2110 B 2	2111 A 2	2111 A 2	2119 A 1
2105 B 2	2113 B 4	2120 A 4	2127 A 4	2109 B 4	2117 B 4	2111 B 2	2112 A 4	2112 A 4	2120 A 1

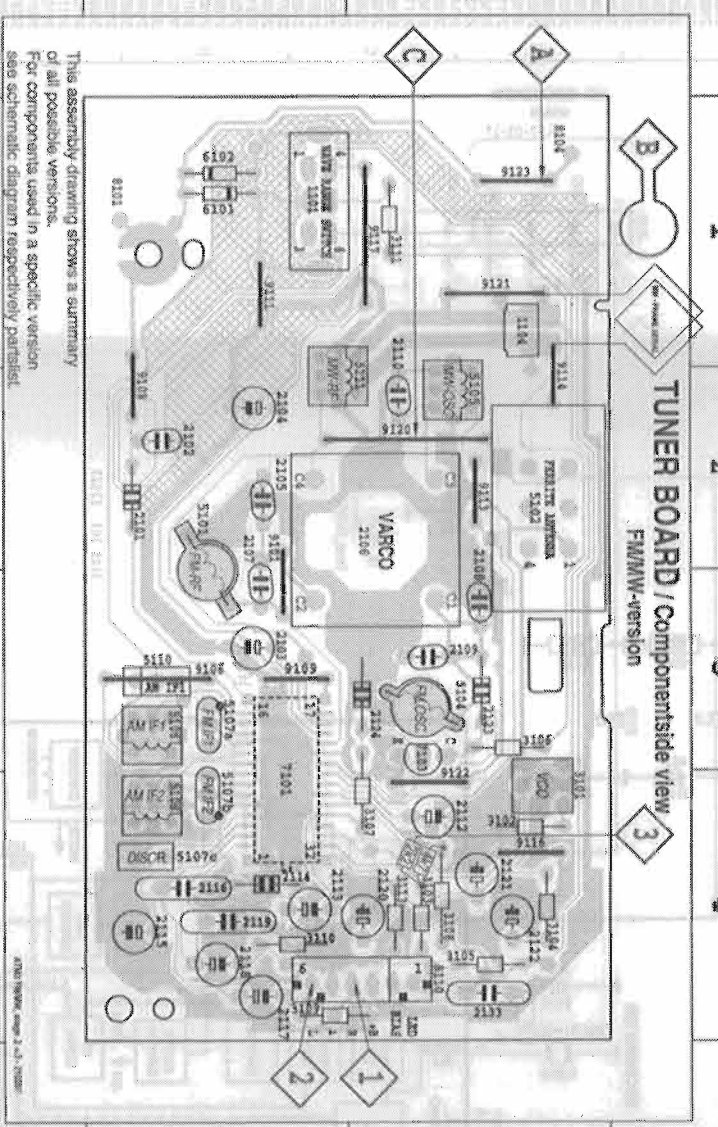

1101 B 1	2106 A 2	2114 B 4	2121 A 4	2103 A 4	2110 B 4	2106 B 3	2101 B 1	2101 B 3	2116 A 4
1104 A 1	2107 B 3	2115 B 4	2122 A 3	2104 A 4	2113 A 1	2107 B 2	2106 B 2	2107 B 2	2117 A 1
1101 B 2	2108 A 3	2116 A 4	2123 A 3	2105 A 4	2113 B 4	2107 B 4	2108 B 2	2108 B 2	2117 A 1
1102 B 2	2109 A 3	2117 B 4	2124 A 3	2106 A 4	2114 A 3	2108 B 3	2109 B 2	2109 B 2	2118 A 1
1103 B 3	2110 A 2	2118 B 4	2125 A 4	2107 A 4	2115 A 4	2109 B 4	2110 A 1	2110 A 1	2118 A 1
1104 B 2	2112 A 4	2119 B 4	2126 A 4	2108 A 4	2116 A 4	2110 B 2	2111 A 2	2111 A 2	2119 A 1
2105 B 2	2113 B 4	2120 A 4	2127 A 4	2109 B 4	2117 B 4	2111 B 2	2112 A 4	2112 A 4	2120 A 1

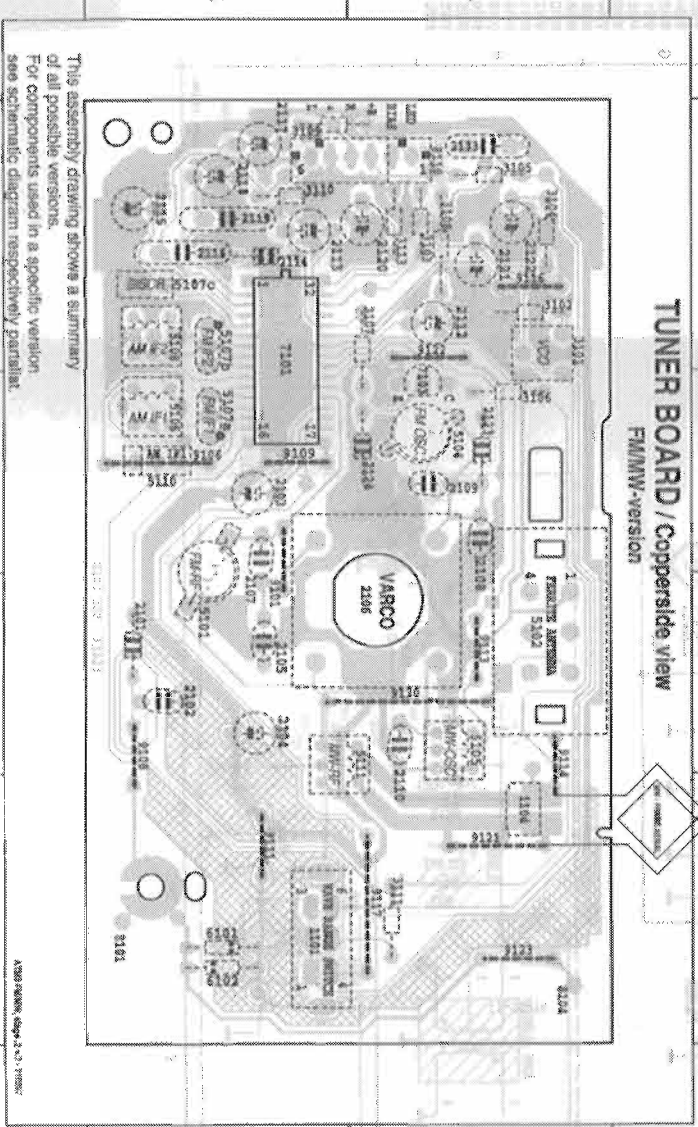

**TUNER ADJUSTMENT TABLE (ATM3 FM/AM - versions with AM-frame aerial)**

Waverange	Input Frequency	Input	Set tuned to	Adjust	Measure on	Scope / Counter
FM 87.5 - 108 MHz	87.35 MHz 108.05 MHz	A $\Delta f = \pm 500\text{kHz}$ $V_{RF} = 100\mu\text{V}$	lower band end	5104	1 or 2	
			upper band end	2106 C1	1 or 2	
MW 525 - 1607 KHz (530 - 1710 KHz) 1)	512 KHz (520 KHz) 1635 KHz (1730 KHz)	C $\Delta f = \pm 30\text{kHz}$ $V_{RF} = 100\mu\text{V}$	lower band end	5105	1 or 2	
			upper band end	2106 C3	1 or 2	
FM - RF 87.5 - 108 MHz	87.5 MHz 108 MHz	A $\Delta f = \pm 500\text{kHz}$ $V_{RF} = 10\mu\text{V}$	87.5 MHz 108 MHz	5101 2106 C2	1 or 2	
VCO		A				
FM	98 MHz	continuous wave $V_{RF} = 1\text{ mV}$	98 MHz	3101	3	
AM - IF	468 KHz					
AM	connect pin 24 of IC 7101 (AM Occ) with short wire to ground	C $\Delta f = \pm 15\text{kHz}$ $V_{RF} = 10\text{mV}$	5106 5108	5106 5108	1 or 2 1 or 2	
AM - RF	560 KHz					
MW	1500 KHz	B $\Delta f = \pm 30\text{kHz}$ $V_{RF}$ as low as possible	560 KHz 1500 KHz	5111 2106 C4	1 or 2 1 or 2	

1) for USA /17  
2) RC-network serves for damping the IF-filter while adjusting the other one.



# ANALOG TUNER BOARD (ATM3F)

## FM/LW/MW and FM/SW/MW versions

VERSION	FM	EAST EUROPE
2105	22p	8p2
2106	20p	4p
2107	22p	390p
2108	4p7	5p6
2109	4p7	2p2
5101	55nH	91nH
5104	40nH	72nH
9101	JMP	

U ..... provisional only  
 Y ..... value for SW-EU (5.9-18.1MHz)  
 SW ..... only for FM/SW/MW version  
 LW ..... only for FM/LW/MW version

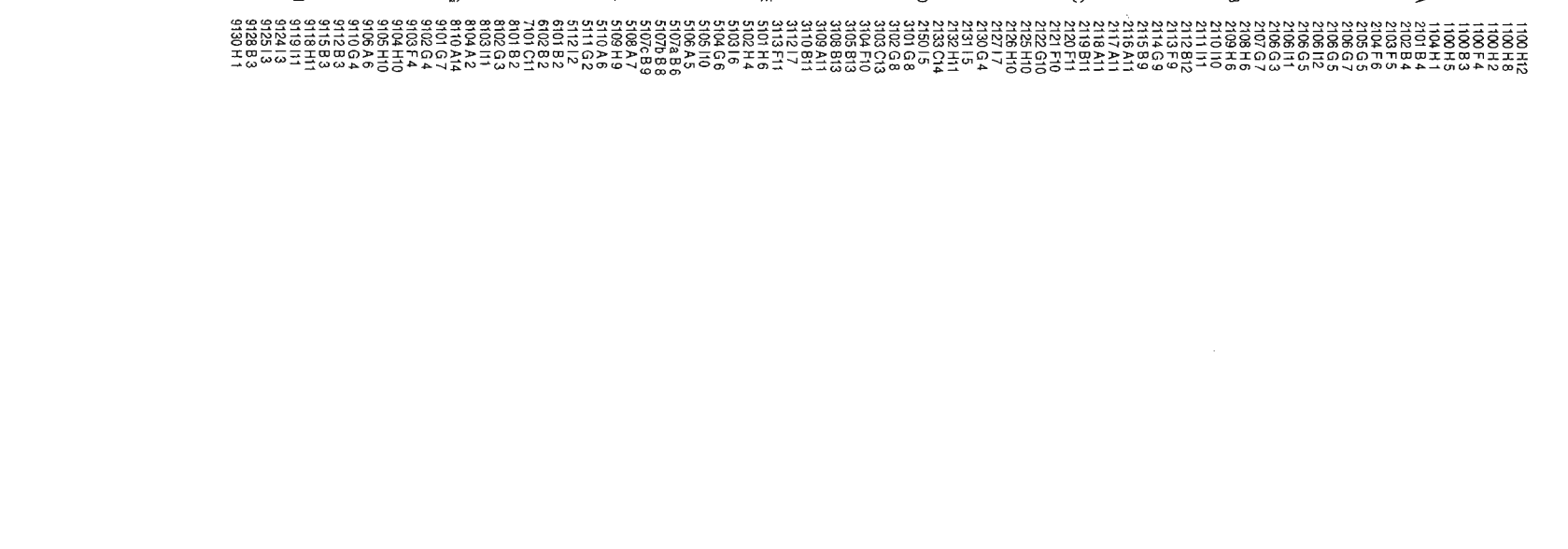
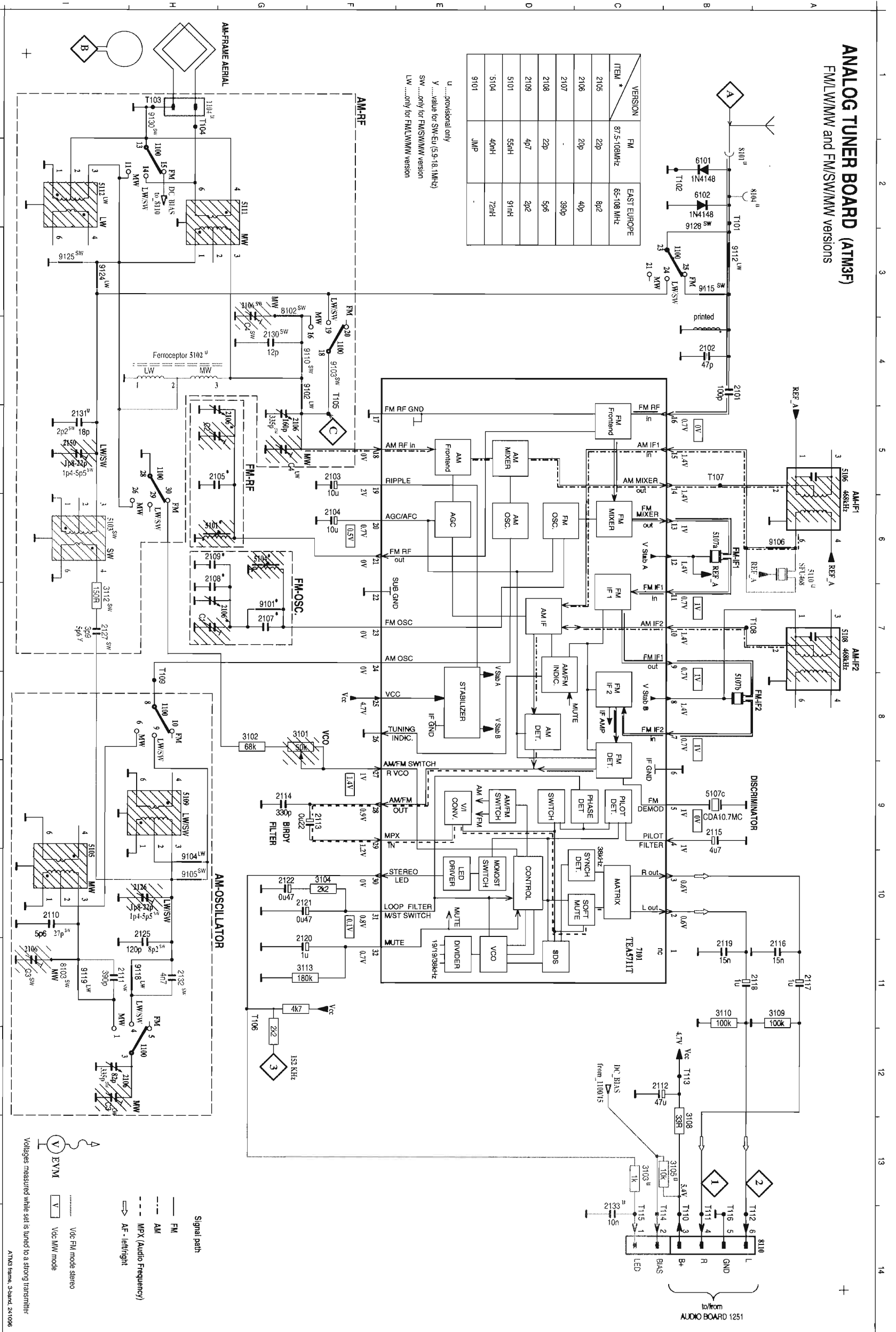



1100 B 1	2108 A 3	2117 B 4	2120 B 2	5105 A 4	5104 A 3	5111 A 1	8110 A 4	9109 B 3	9118 B 1	9190 A 1
1106 A 1	2109 A 3	2118 B 4	2112 B 1	5109 A 4	5105 A 1	5112 A 1	8110 A 2	9110 A 2	9119 A 2	
2101 B 3	2110 B 1	2119 B 4	2122 B 2	5109 B 4	5106 B 3	6101 B 1	9101 A 3	9110 A 1	9120 A 1	
2103 B 2	2111 A 2	2120 A 4	2123 B 3	5110 B 4	5107 B 2	6102 B 1	9103 B 2	9112 B 1	9121 A 1	
2104 B 3	2112 A 4	2121 A 4	2124 B 4	5110 B 3	5107 B 3	7101 B 4	9104 B 1	9113 B 1	9122 A 1	
2105 B 2	2113 B 4	2122 A 4	2125 B 4	5111 A 4	5108 B 4	8101 B 1	9105 B 1	9114 A 2	9123 A 1	
2106 A 2	2114 B 4	2123 A 4	2126 B 1	5101 B 2	5108 B 3	8102 B 2	9106 B 1	9115 B 1	9124 A 1	
2107 A 3	2115 B 4	2124 B 2	2127 B 2	5102 B 2	5109 B 2	8200 A 2	9207 A 1	9116 A 1	9125 A 1	
				5103 B 2	5110 B 1	8104 A 1	9108 B 2	9117 A 1	9126 B 1	

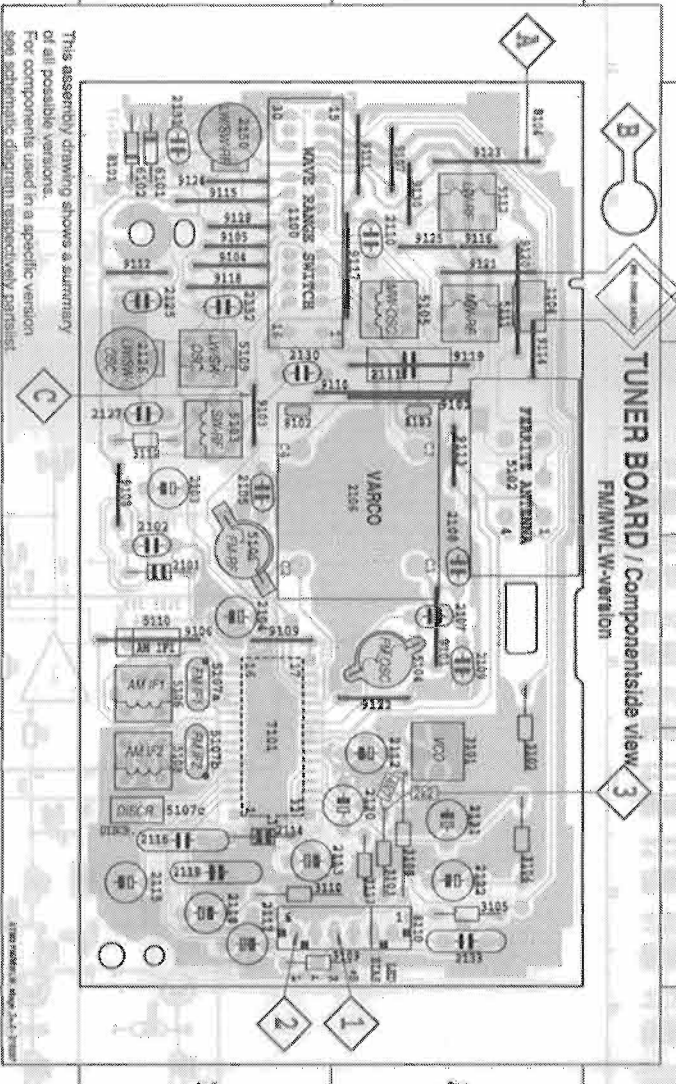

1100 B 1	2108 A 3	2117 B 4	2120 B 2	5105 A 4	5104 A 3	5111 A 1	8110 A 4	9109 B 3	9118 B 1	9190 A 1
1104 A 1	2109 A 3	2118 B 4	2112 B 1	5109 A 4	5105 A 1	5112 A 1	8110 A 2	9110 A 2	9119 A 2	
2101 B 3	2110 B 1	2119 B 4	2122 B 2	5109 B 4	5106 B 3	6101 B 1	9101 A 3	9110 A 1	9120 A 1	
2103 B 2	2111 A 2	2120 A 4	2123 B 3	5110 B 4	5107 B 2	6102 B 1	9103 B 2	9112 B 1	9121 A 1	
2104 B 3	2112 A 4	2121 A 4	2124 B 4	5110 B 3	5107 B 3	7101 B 4	9104 B 1	9113 B 1	9122 A 1	
2105 B 2	2113 B 4	2122 A 4	2125 B 4	5111 A 4	5108 B 4	8101 B 1	9105 B 1	9114 A 2	9123 A 1	
2106 A 2	2114 B 4	2123 A 4	2126 B 1	5101 B 2	5108 B 3	8102 B 2	9106 B 1	9115 B 1	9124 A 1	
2107 A 3	2115 B 4	2124 B 2	2127 B 2	5102 B 2	5109 B 2	8200 A 2	9207 A 1	9116 A 1	9125 A 1	
				5103 B 2	5110 B 1	8104 A 1	9108 B 2	9117 A 1	9126 B 1	

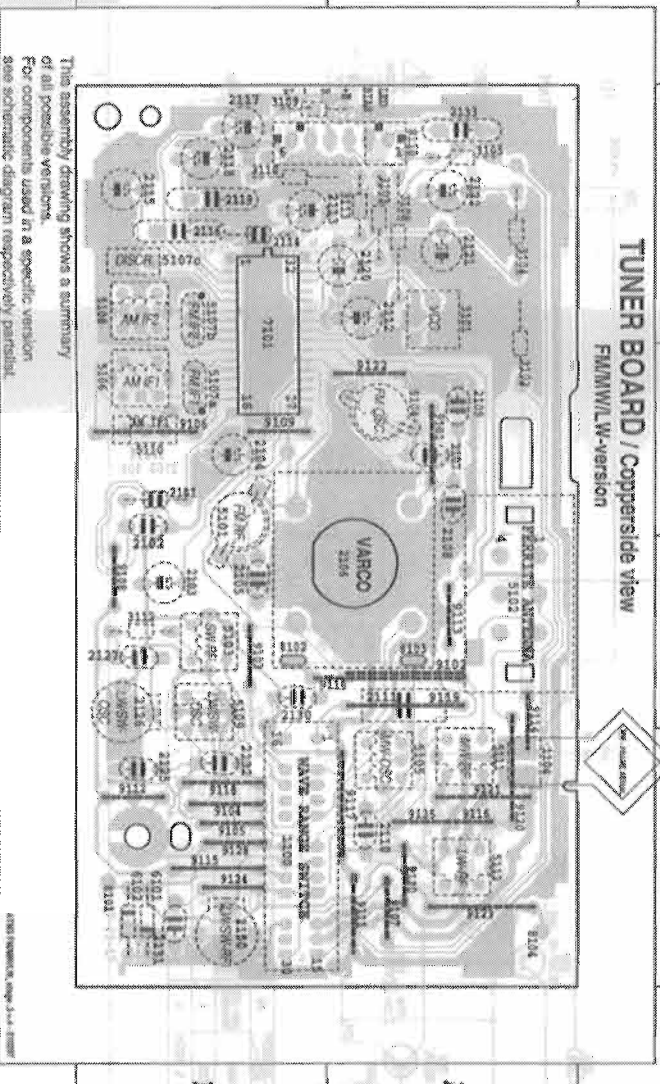

TUNER ADJUSTMENT TABLE ( ATMS FM/LW/MW- versions with AM-frame aerial )

Waverange	Input Frequency	Input	Set tuned to	Adjust	Measure on	Scope / Counter
<b>OSCILLATOR</b>	<b>FM</b> 87.5 - 108 MHz (65 - 108 MHz) <sup>1)</sup>	<b>A</b> 87.35 MHz (64.7 MHz)	lower band end	5104	<b>1</b> or <b>2</b>	
		108.25 MHz	upper band end	2106 C1	<b>1</b> or <b>2</b>	
	<b>MW</b> 525 - 1607 kHz (330 - 1710 kHz) <sup>2)</sup>	512 kHz - (520 kHz)	lower band end	5105	<b>1</b> or <b>2</b>	
		1635 kHz (1730 kHz)	upper band end	2106 C3	<b>1</b> or <b>2</b>	
<b>LW</b> <sup>3)</sup> 148.5 - 284 kHz	147 kHz	lower band end	5109	<b>1</b> or <b>2</b>		
	291 kHz	upper band end	2126	<b>1</b> or <b>2</b>		
<b>FM - RF</b>	<b>FM</b> 87.5 - 108 MHz (65 - 108 MHz) <sup>1)</sup>	<b>A</b> 87.5 MHz (65 MHz) $\Delta f = \pm 500 \text{ kHz}$ $V_{RF} = 100 \mu\text{V}$	5101	<b>1</b> or <b>2</b>		
			2106 C2	<b>1</b> or <b>2</b>		
<b>VCO</b>	<b>FM</b> 98 MHz $V_{RF} = 1 \text{ mV}$	<b>A</b> continuous wave $V_{RF} = 1 \text{ mV}$	3101	<b>3</b>		
				<b>3</b>		
<b>AM - IF</b>	<b>AM</b> 488 kHz connected pin 24 of IC 7101 (AM Osc) with short wire to ground	<b>C</b> $\Delta f = \pm 15 \text{ kHz}$ $V_{RF} = 10 \text{ mV}$	5106	<b>1</b> or <b>2</b>		
			5108	<b>1</b> or <b>2</b>		
<b>AM - RF</b>	<b>AM</b> 560 kHz	<b>B</b>	5111	<b>1</b> or <b>2</b>		
			2106 C4	<b>1</b> or <b>2</b>		
<b>MW</b>	1500 kHz	<b>B</b>	5112	<b>1</b> or <b>2</b>		
			2150	<b>1</b> or <b>2</b>		
<b>LW</b> <sup>3)</sup>	260 kHz	<b>B</b>	2150	<b>1</b> or <b>2</b>		
				<b>1</b> or <b>2</b>		

1) for East Europe /14 2) for USA /17 3) LW not for all versions  
4) PC-network serves for damping the IF-filter while adjusting the other one.

# AUDIO BOARD - CIRCUIT DIAGRAM

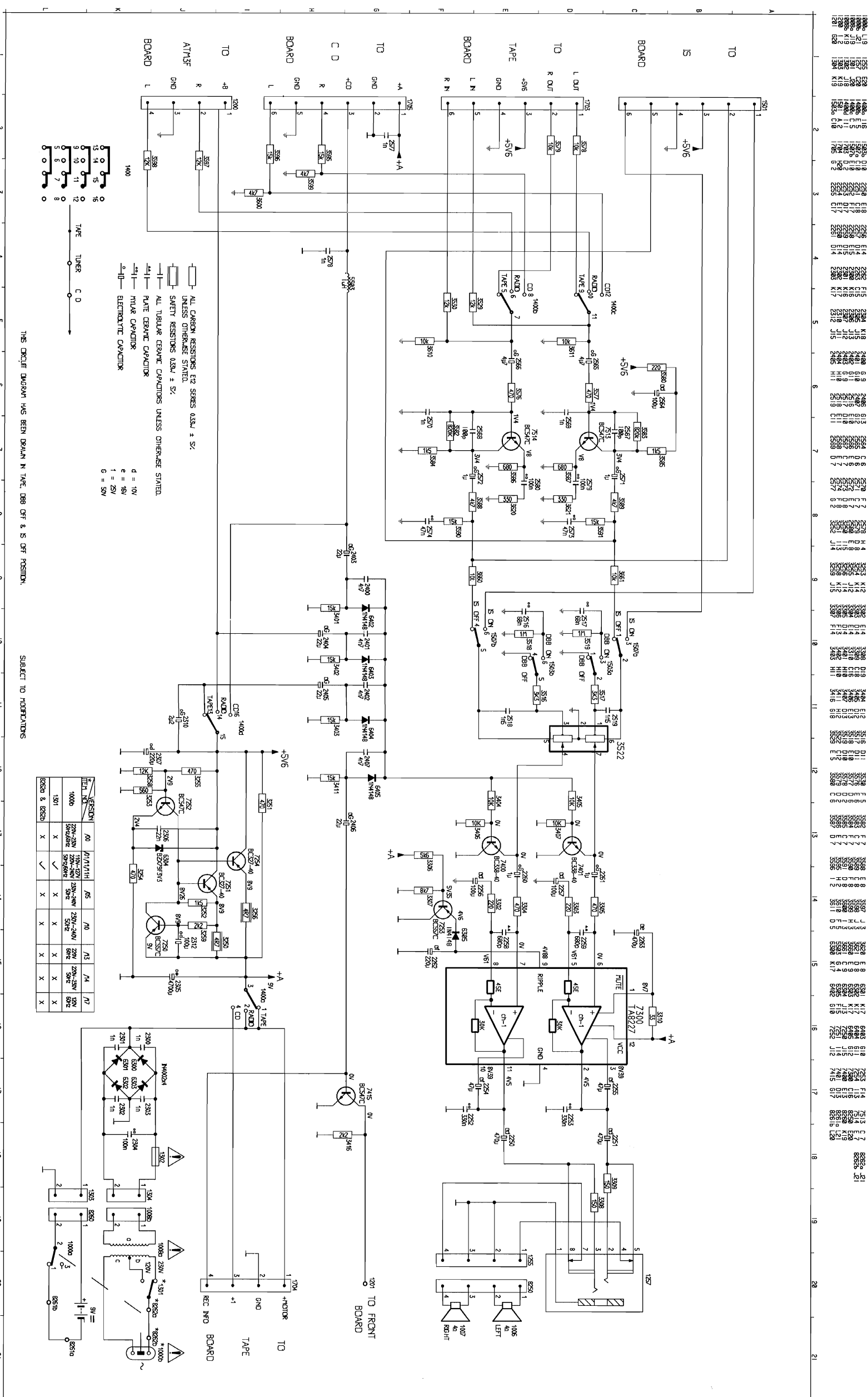

THIS CIRCUIT DIAGRAM HAS BEEN DRAWN IN TAPE, DB9 OFF & IS OFF POSITION.

SUBJECT TO MODIFICATIONS

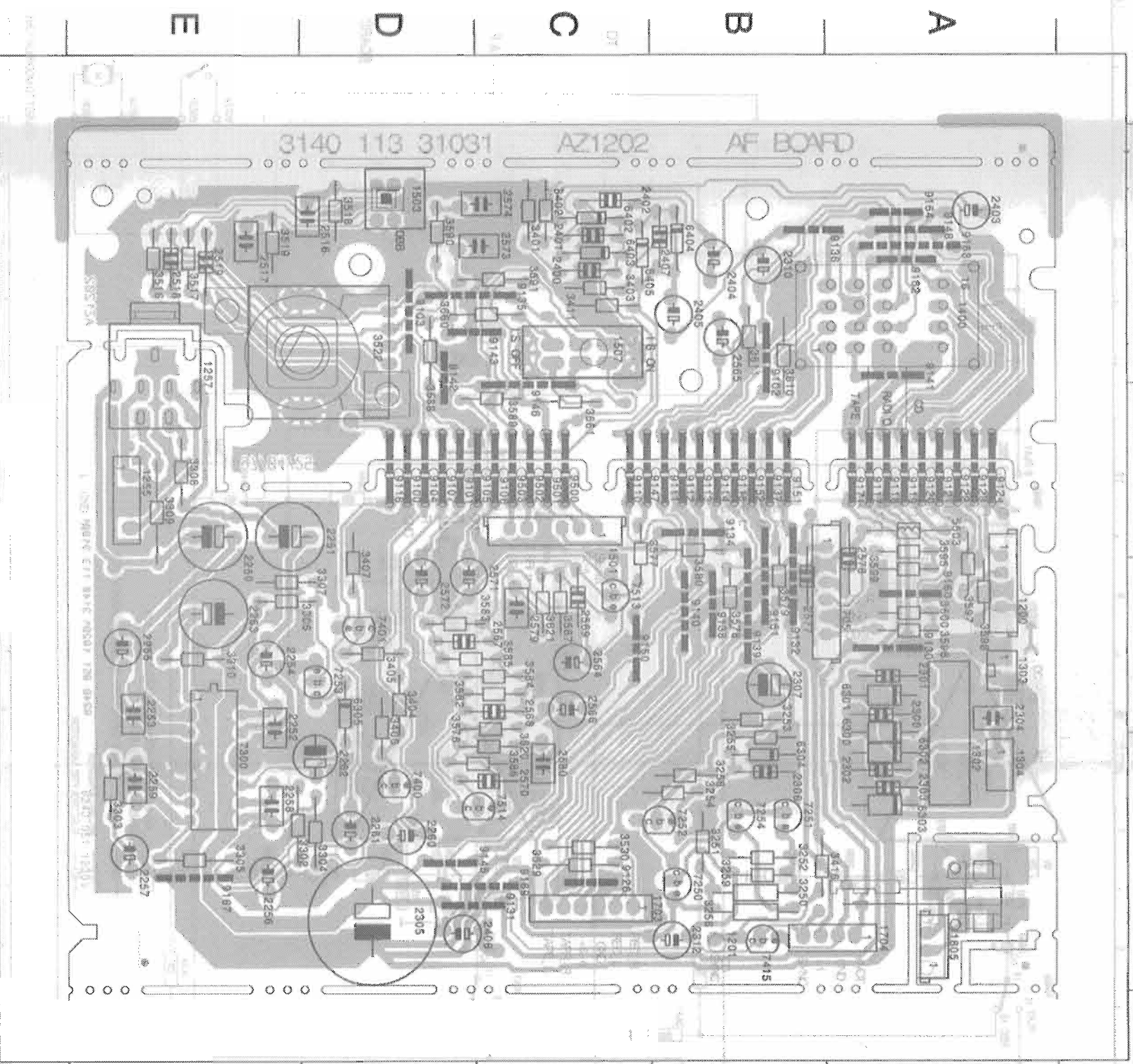

1200	A 3	3263	B 3	6404	B 1	9502	C 2
1255	E 2	3254	B 4	6405	C 1	9503	C 2
1287	E 2	3255	B 4	7250	B 4		
1302	A 4	3258	B 4	7251	B 4		
1303	A 3	3259	B 4	7252	B 4		
1304	A 4	3259	B 4	7253	D 3		
1501	C 2	3902	E 4	7254	B 4		
1503	D 1	3903	E 4	7300	E 4		
1507	C 1	3904	E 4	7400	D 4		
1706	C 4	3905	D 4	7401	D 3		
1704	A 4	3906	E 3	7415	B 4		
1706	A 3	3907	E 3	7513	C 3		
1805	A 4	3908	E 2	7514	C 4		
2250	E 2	3308	E 2	9100	D 2		
2251	E 2	3310	E 3	9101	D 2		
2252	E 3	3401	C 1	9102	B 1		
2253	E 3	3402	C 1	9103	D 1		
2254	E 3	3403	C 1	9104	D 2		
2255	E 3	3404	D 3	9105	C 2		
2256	E 4	3405	D 3	9106	C 2		
2257	E 4	3408	D 3	9107	D 2		
2258	E 4	3407	D 3	9110	C 2		
2258	E 4	3411	C 1	9111	B 2		
2280	D 4	3418	B 4	9112	B 2		
2281	D 4	3516	E 1	9113	B 2		
2282	D 4	3517	E 1	9114	B 2		
2283	D 4	3518	E 1	9115	B 2		
2300	A 3	3519	E 1	9116	D 2		
2301	A 3	3522	D 1	9117	A 2		
2302	A 4	3523	C 4	9118	A 2		
2303	A 4	3530	C 4	9119	A 2		
2304	A 3	3575	C 3	9120	A 2		
2305	D 4	3577	C 2	9121	A 2		
2306	D 4	3578	B 3	9122	A 2		
2307	B 3	3579	B 3	9123	A 2		
2310	B 1	3580	B 2	9124	A 2		
2312	B 4	3582	C 3	9126	C 4		
2400	C 1	3583	D 3	9130	A 3		
2401	C 1	3584	C 3	9131	D 4		
2402	C 1	3585	D 3	9132	B 3		
2403	A 1	3586	C 4	9134	B 2		
2404	B 1	3587	C 3	9135	D 1		
2405	B 1	3588	D 1	9136	B 1		
2406	D 4	3589	C 2	9137	B 2		
2407	B 1	3590	D 1	9138	B 3		
2516	D 1	3591	C 1	9139	B 3		
2517	E 1	3595	A 2	9140	B 3		
2518	E 1	3596	A 3	9141	A 1		
2519	E 1	3597	A 3	9142	D 1		
2564	C 3	3598	A 3	9143	D 1		
2565	B 1	3599	A 3	9145	D 4		
2566	C 3	3600	A 3	9146	C 2		
2567	D 3	3610	B 1	9147	C 2		
2568	C 3	3611	B 1	9148	A 1		
2569	C 3	3620	C 4	9150	C 3		
2570	C 4	3621	C 3	9151	B 2		
2571	D 3	3660	C 1	9152	B 2		
2572	D 3	3661	C 2	9160	A 3		
2573	C 1	5503	A 2	9161	B 3		
2574	C 1	6300	A 3	9162	A 1		
2575	B 3	6301	A 3	9163	A 1		
2576	A 3	6302	A 4	9164	A 1		
2579	C 3	6303	A 4	9167	E 4		
2580	C 4	6304	B 4	9169	C 4		
3250	B 4	6402	C 1	9171	A 2		
3251	B 4	6402	C 1	9500	C 2		
3252	B 4	6403	C 1	9501	C 2		

# TAPE DECK BOARD - CIRCUIT DIAGRAM

1700	1703	1701	8022a	8022b	8022c	8022d	8022e	8022f	8022g	8022h	8022i	8022j	8022k	8022l	8022m	8022n	8022o	8022p	8022q	8022r	8022s	8022t	8022u	8022v	8022w	8022x	8022y	8022z
------	------	------	-------	-------	-------	-------	-------	-------	-------	-------	-------	-------	-------	-------	-------	-------	-------	-------	-------	-------	-------	-------	-------	-------	-------	-------	-------	-------

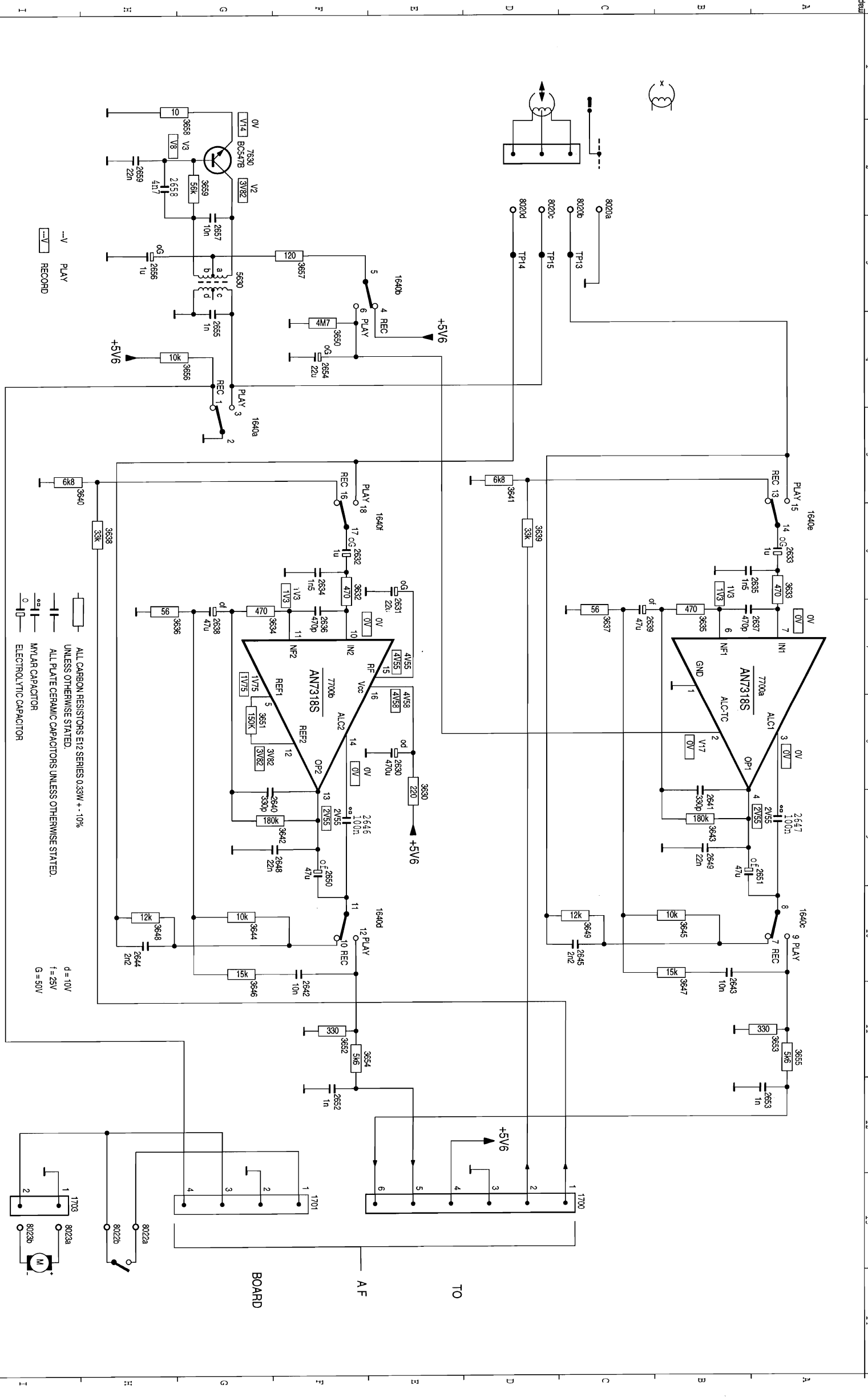

THIS CIRCUIT DIAGRAM HAS BEEN DRAWN IN REC POSITION.

ALL CARBON RESISTORS E12 SERIES 0.33W +/- 10% UNLESS OTHERWISE STATED.  
 ALL PLATE CERAMIC CAPACITORS UNLESS OTHERWISE STATED.  
 MIL-PRC CAPACITOR  
 ELECTROLYTIC CAPACITOR

d = 10V  
 f = 28V  
 G = 50V

SUBJECT TO MODIFICATIONS

**TAPE DECK BOARD - LAYOUT DIAGRAM**

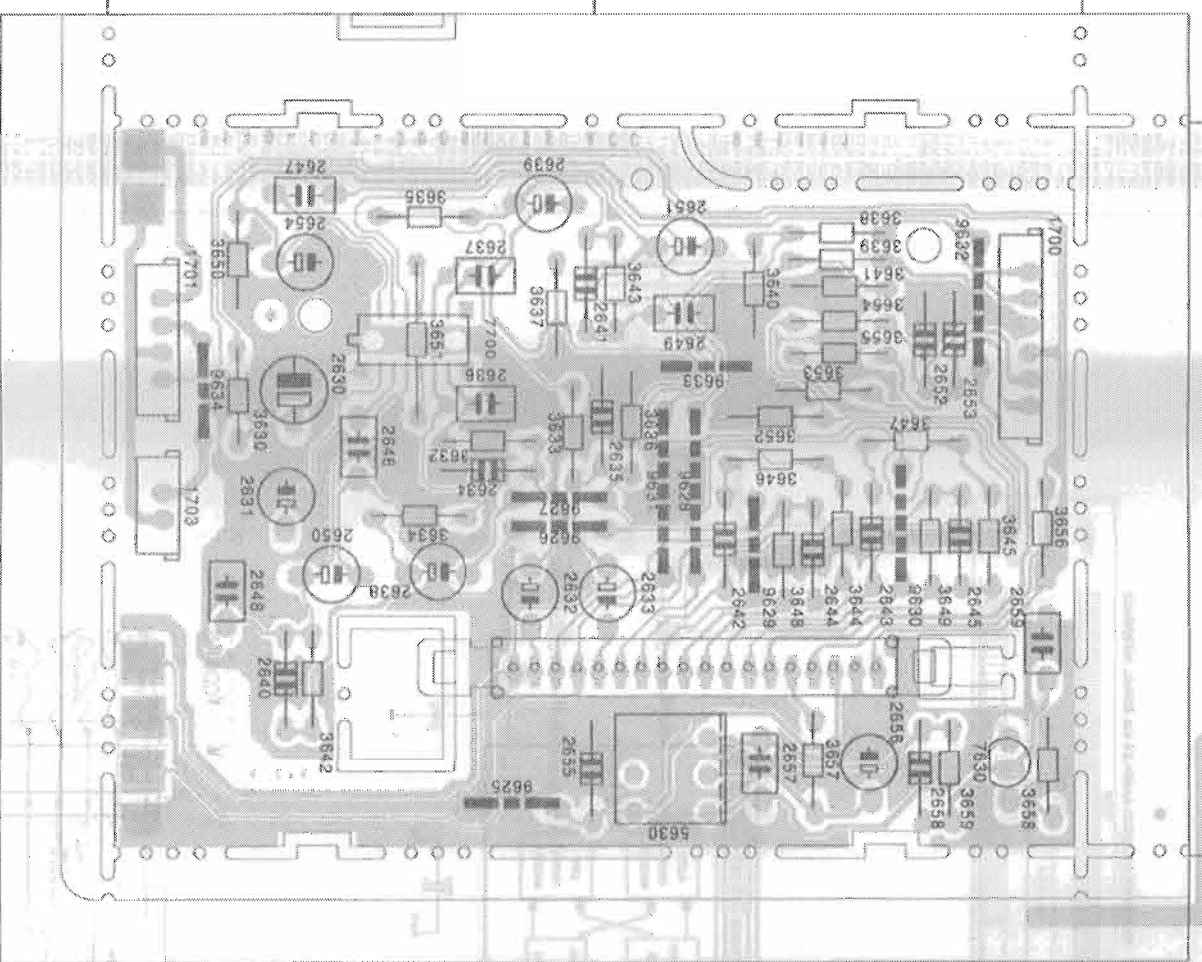

- 1619 A1 1628 A1 1639 A2 2635 A1 2645 A1 2655 A2 3636 A1 3646 A1 3655 A1 9628 A1 PADD A2
- 1620 A1 1630 A1 1640 A2 2636 A2 2646 A2 2656 A1 3637 A2 3647 A1 3657 A1 9629 A1 PADD A2
- 1621 A2 1631 A1 1700 A1 2637 A2 2647 A2 2657 A1 3638 A1 3648 A1 3658 A1 9630 A1 PADD A2
- 1622 A2 1632 A1 1701 A2 2638 A2 2648 A2 2658 A1 3639 A1 3649 A1 3659 A1 9631 A1
- 1623 A1 1633 A1 1703 A2 2639 A2 2649 A1 2659 A1 3640 A1 3650 A2 5630 A1 9632 A1
- 1624 A1 1634 A1 2630 A2 2640 A2 2650 A2 3630 A2 3641 A1 3651 A2 7630 A1 9633 A1
- 1625 A1 1635 A1 2631 A2 2641 A2 2651 A1 3632 A2 3642 A2 3652 A1 7700 A2 9635 A2
- 1626 A1 1636 A1 2632 A2 2642 A1 2652 A1 3633 A2 3643 A1 3653 A1 9625 A2 PADD A2
- 1627 A1 1637 A2 2633 A1 2643 A1 2653 A1 3634 A2 3644 A1 3654 A1 9626 A2 PADD A2
- 1628 A1 1638 A2 2634 A2 2644 A1 2654 A2 3635 A2 3645 A1 3655 A1 9627 A2 PADD A2

**INCREDIBLE SOUND BOARD - CIRCUIT DIAGRAM**

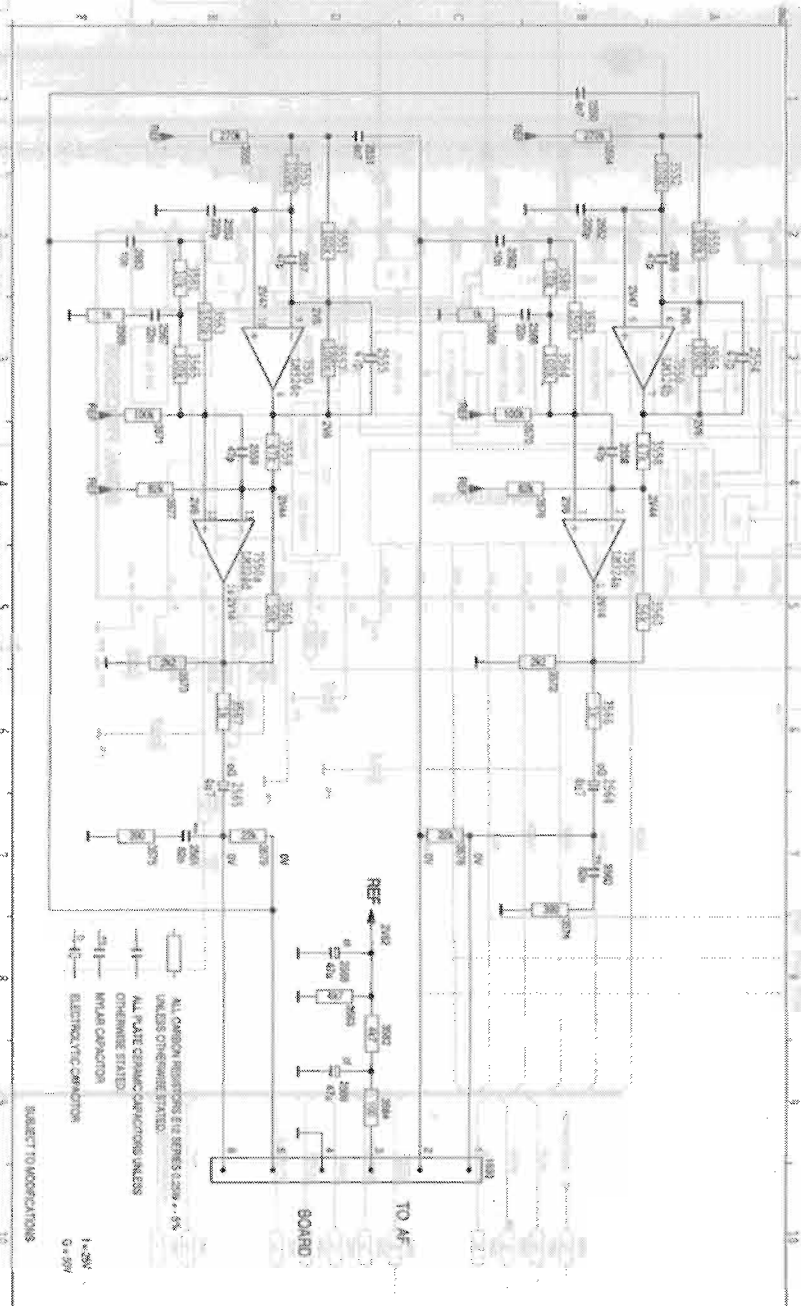

**CASSETTE ADJUSTMENT**

Adjustment	Cassette	SK ...	Tape Deck	Measure on	Read on	Adjust with	Adjust to
Head Azimuth	SBC420*	10KHz	Tape	Play	H/P jack	mV meter	Left hand Screw R/P Head L = R
Tape speed	SBC420*	3150Hz	Tape	Play	H/P jack	Wow and flutter meter	**a

\*SBC420 : 4822 397 30071

\*\*a The maximum permissible speed deviation is ± 3%.  
Moreover, the wow and flutter value can be read.

INCREDIBLE SOUND BOARD - CIRCUIT DIAGRAM

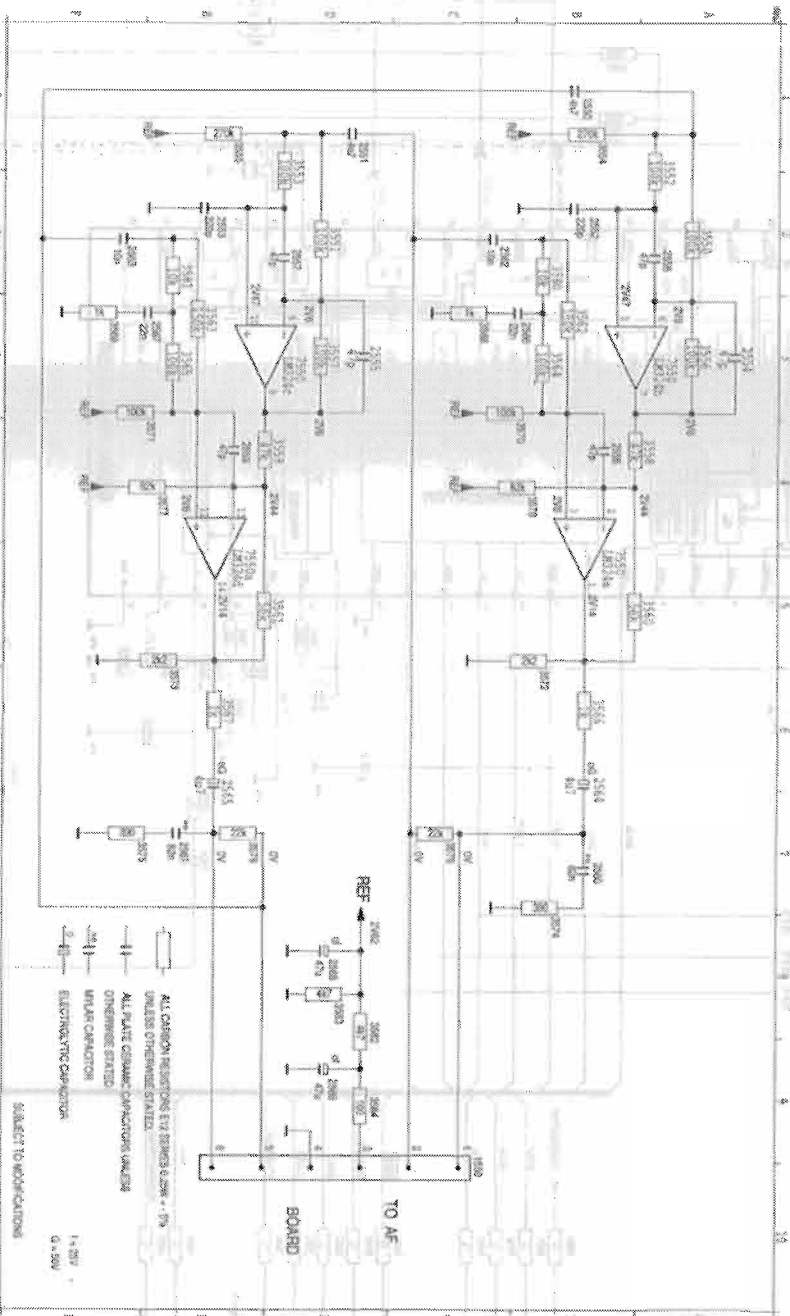

INCREDIBLE SOUND BOARD - LAYOUT DIAGRAM

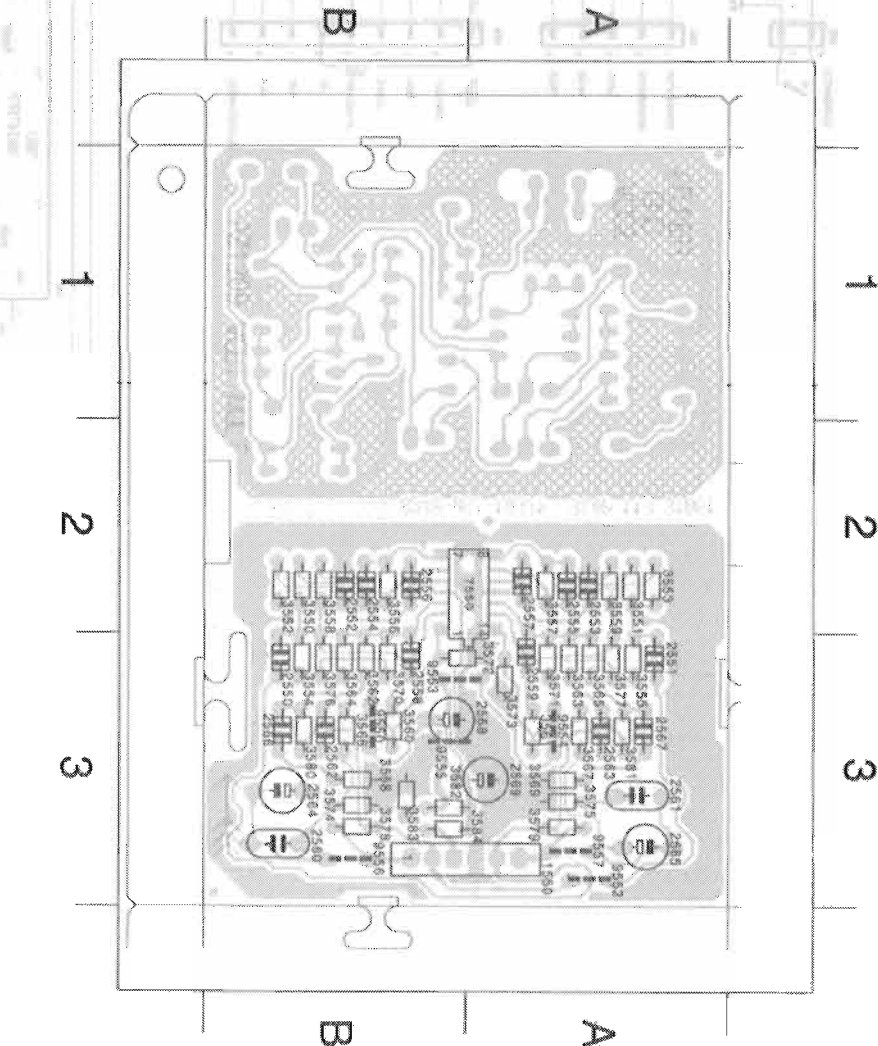

1550 B 3	3563 A 3
2550 B 3	3564 B 3
2551 A 3	3565 A 3
2552 B 2	3566 B 3
2553 A 2	3567 A 3
2554 B 2	3568 B 3
2555 A 2	3569 A 3
2556 B 2	3570 B 3
2557 A 2	3571 A 3
2558 B 3	3572 B 3
2559 A 3	3573 A 3
2560 B 3	3574 B 3
2561 A 3	3575 A 3
2562 B 3	3576 B 3
2563 A 3	3577 A 3
2564 B 3	3578 B 3
2565 A 3	3579 A 3
2566 B 3	3580 B 3
2567 A 3	3581 A 3
2568 B 3	3582 B 3
2569 A 3	3583 B 3
2570 B 3	3584 B 3
3551 A 2	7550 A 2
3552 B 2	9550 A 2
3553 A 3	9551 A 3
3554 B 3	9552 A 3
3555 A 3	9553 B 3
3556 B 2	9554 A 3
3557 A 2	9555 B 3
3558 B 2	9556 B 3
3559 A 2	9557 A 3
3560 B 3	
3561 A 3	
3562 B 3	

CASSETTE ADJUSTMENT

Adjustment	Cassette	SK ...	Tape Deck	Measure on	Read on	Adjust with	Adjust to
Head Azimuth	SBC420*	10KHz	Tape	Play	H/P jack	mV meter	Left hand Screw R/P Head L=R
Tape speed	SBC420*	3150Hz	Tape	Play	H/P jack	Wow and flutter meter	Preset VR in motor **a

\*SBC420 : 4822 397 30071

\*\*a The maximum permissible speed deviation is ± 3%.  
Moreover, the wow and flutter value can be read.

# CD97 - CIRCUIT DIAGRAM

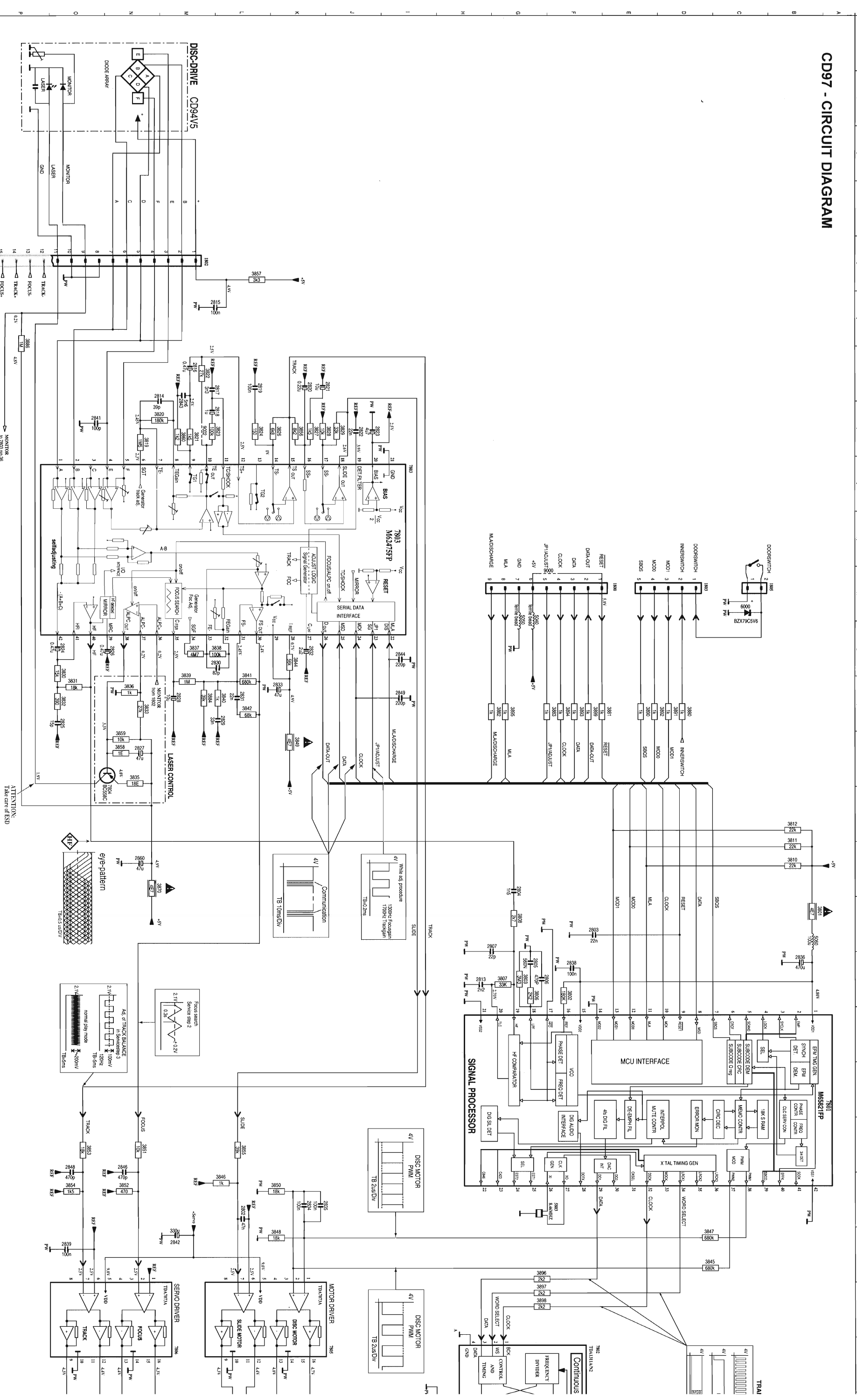

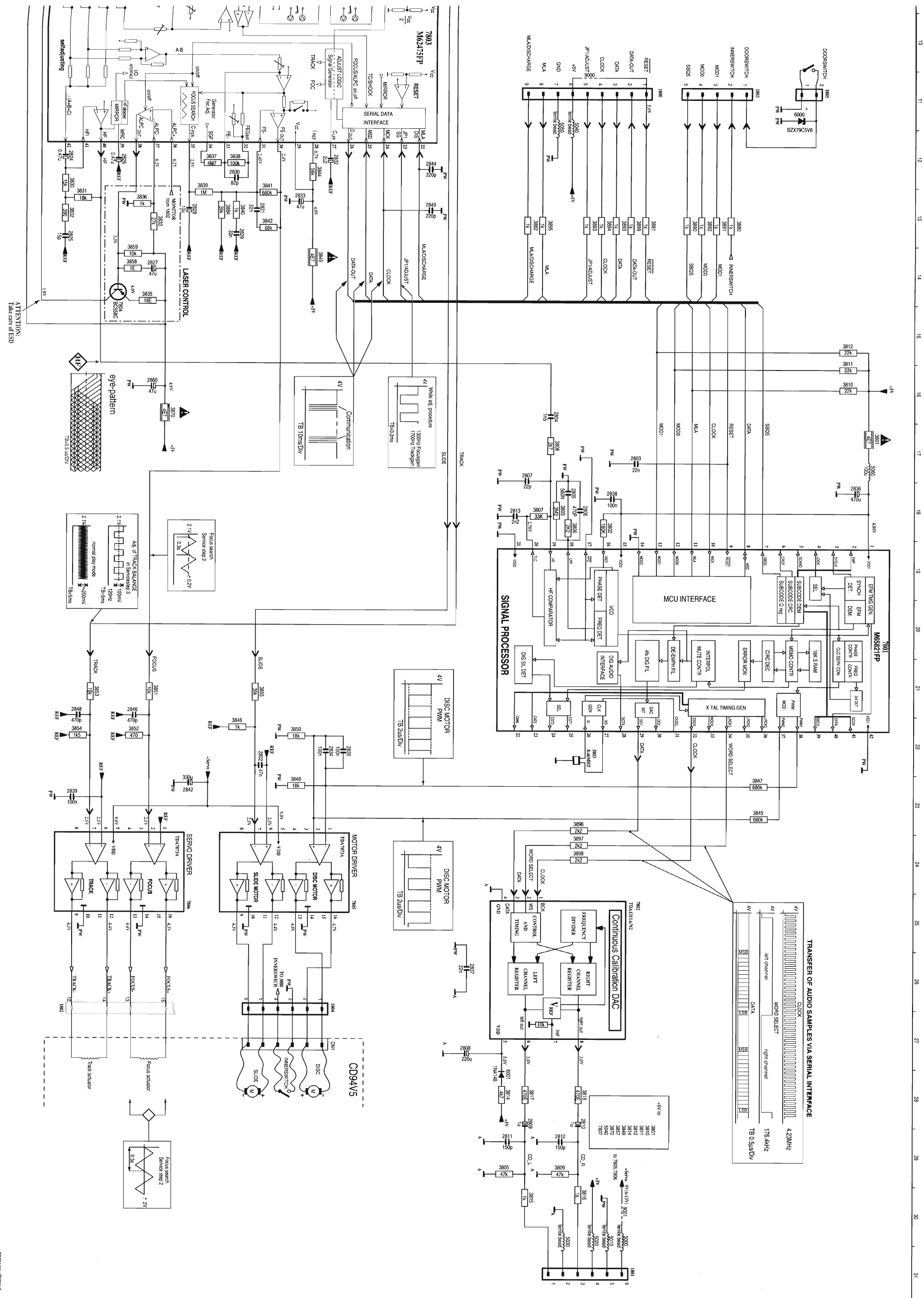

CD97 (M62475FP)

1300	E29
1301	E31
1302	O5
1303	D11
1304	K06
1305	K07
1306	F17
1307	F18
1308	G18
1309	G19
1310	G28
1311	H29
1312	H39
1313	H49
1314	M7
1315	L6
1316	L7
1317	L8
1318	L9
1319	L7
1320	L7
1321	L7
1322	J8
1323	J8
1324	J8
1325	O15
1326	N12
1327	N14
1328	N15
1329	L13
1330	L13
1331	L13
1332	K13
1333	K13
1334	K13
1335	K13
1336	K13
1337	K13
1338	K13
1339	K13
1340	K13
1341	K13
1342	K13
1343	K13
1344	K13
1345	K13
1346	K13
1347	K13
1348	K13
1349	K13
1350	K13
1351	K13
1352	K13
1353	K13
1354	K13
1355	K13
1356	K13
1357	K13
1358	K13
1359	K13
1360	K13
1361	K13
1362	K13
1363	K13
1364	K13
1365	K13
1366	K13
1367	K13
1368	K13
1369	K13
1370	K13
1371	K13
1372	K13
1373	K13
1374	K13
1375	K13
1376	K13
1377	K13
1378	K13
1379	K13
1380	K13
1381	K13
1382	K13
1383	K13
1384	K13
1385	K13
1386	K13
1387	K13
1388	K13
1389	K13
1390	K13
1391	K13
1392	K13
1393	K13
1394	K13
1395	K13
1396	K13
1397	K13
1398	K13
1399	K13
1400	K13





# CD - SERVICE TESTPROGRAM

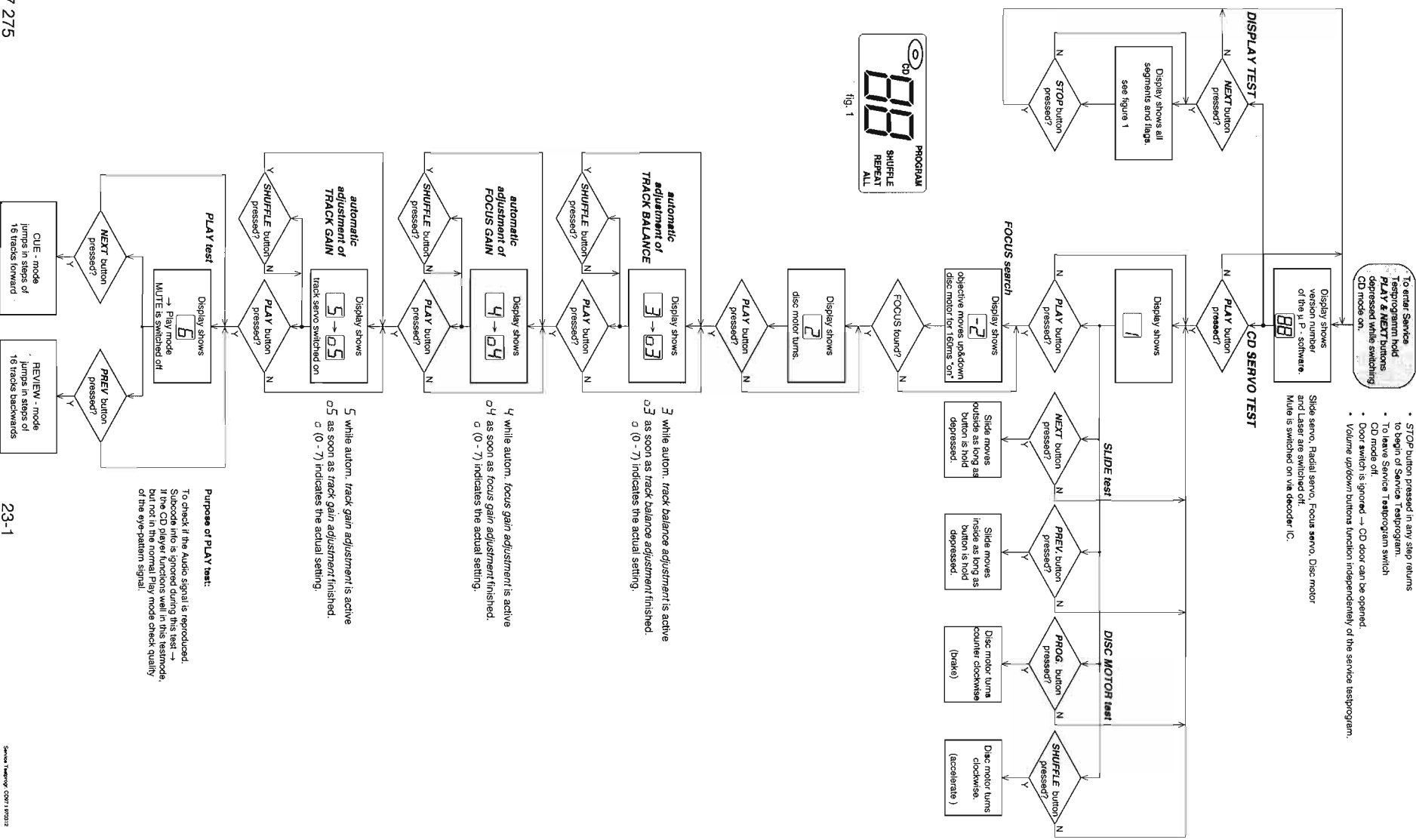

# CD STARTUP - PROCEDURE

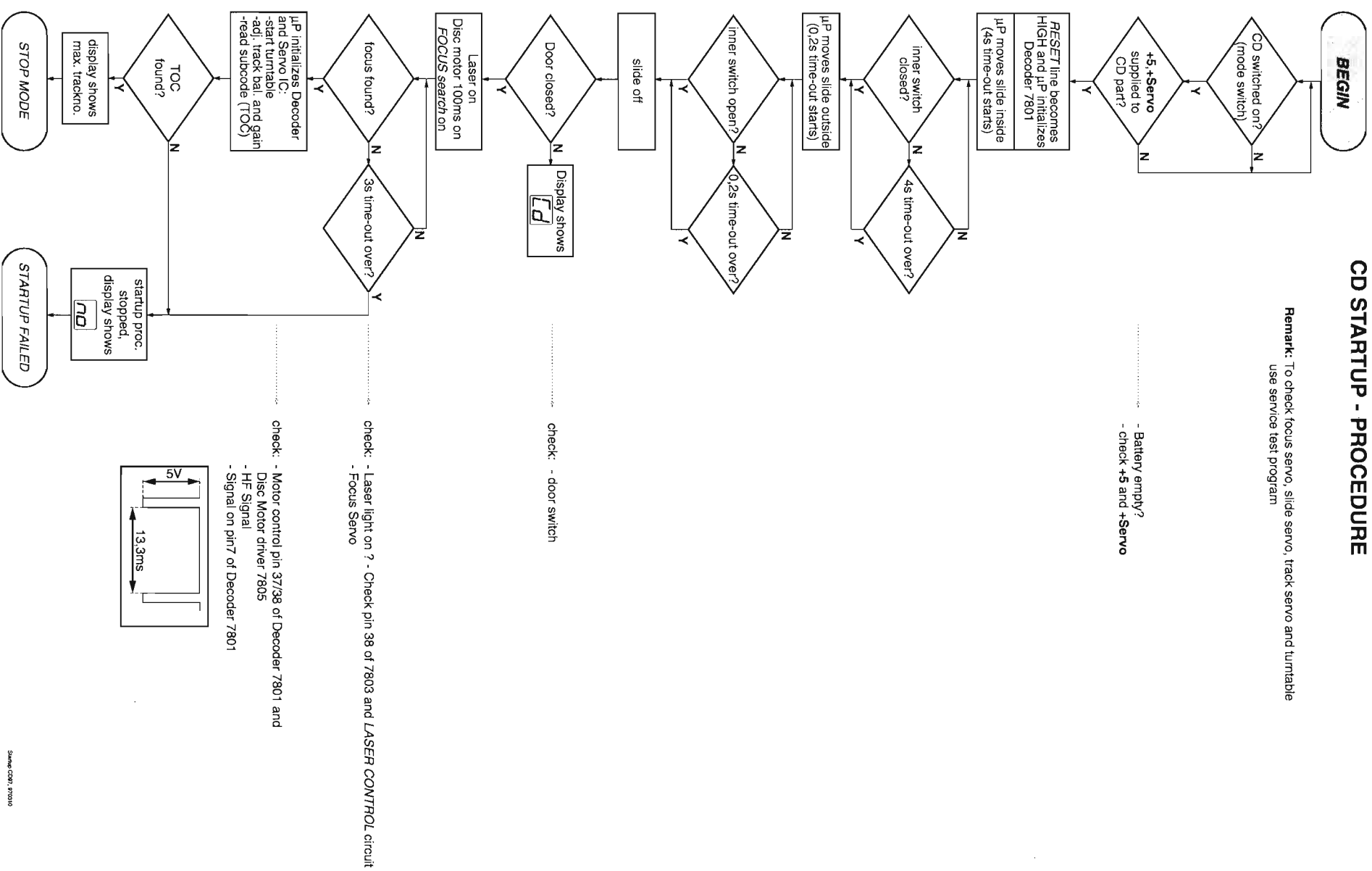

## Abbreviations and Pin-descriptions of CD ICs

### SERVO PROCESSOR M62475FP

Pin	Name	Direction	Description
1-3	A, B, C	Diode array → Servo processor	Current input ( central photo diode signal input )
4-5	E, F	Diode array → Servo processor	Current input ( satellite photo diode signal input )
6	SGT	Servo processor → Track servo	Signal generator output to track servo, sends 1700Hz for adjustment procedure
7	TE -	-	Inverting input of trackerror amplifier
8	TEGain	-	Gain control pin of track error amplifier
9	TG1	-	Track Gain 1 - switch: controls the gain of the track servo amplifier
10	TE out	-	Track Error amplifier output
11	TC/Shock	-	Track Cross/Shock detector input
12	TS +	-	Non inverting input of track servo amplifier
13	TG2	-	Track Gain 2 - switch: controls the gain of the track servo amplifier
14	TS -	-	Inverting input of track servo amplifier
15	TS out	Servo processor → Servo driver	Output of track servo amplifier
16	SS +	-	Non inverting input of slide servo amplifier
17	SS -	-	Inverting input of slide servo amplifier
18	Slide out	Servo processor → Motor driver	Output of slide servo amplifier
19	DET FIL	-	Pin for connection of DETECTION Filter capacitor of ADJUST LOGIC
20	BIAS	Servo processor → external electronic	Reference Voltage output Vcc2 of internal BIAS-generator
21	GND	-	Ground connection pin ( negative supply )
22	MLA/DIS	µP → Servo processor	Serial interface Microprocessor Latch control / DIScharge control for adjustment
23	JP1/SG	µP → Servo processor	Serial interface Clock input line
24	MCK	µP → Servo processor	Serial interface Data input line
25	MSD	µP → Servo processor	Serial interface Data output line
26	Dout	Servo processor → µP	Pin for connection of Low Pass Filter capacitor for ADJUST LOGIC
27	CLPF	-	Reference current input
28	IREF	-	Positive supply connection pin ( 4V - 5.5V )
29	VCC	-	Output of focus servo amplifier
30	FSout	Servo processor → Servo driver	Inverting input of focus servo amplifier
31	FS -	-	Gain control pin of focus error amplifier
32	FEgain	-	Inverting input of focus error amplifier
33	FE -	-	Signal generator output to focus servo, sends 1300Hz for adjust. procedure
34	SGF	Servo processor → Focus servo	Charge capacitor for Focus Search triangle-generator
35	CFSR	-	Non inverting input of Automatic laser Power Control amplifier
36	APC +	-	Inverting input of Automatic laser Power Control amplifier
37	APC -	-	Output of Automatic laser Power Control amplifier
38	APC out	Servo processor → Laser driver	Connection pin for capacitor of Mirror detector
39	MRC	-	Output of HF amplifier
40	HF	Servo processor → Decoder	Inverting input of HF amplifier
41	HFI	-	Sum output of amplified A, B and C input ( central photo diode signal input )
42	ABC	-	to external ac-coupling capacitor

### SIGNAL PROCESSOR M65821FP

Pin	Name	Direction	Description
1	VDD1	-	+supply for signal processor
2	EMP	not connected	Emphasis flag output
3	SYCLK	not connected	Frame synchronize output
4	LOCK	not connected	Low disc rotation detect output
5	SCAND	not connected	Subcode sync signal detection
6	CRCF	not connected	Subcode Q CRC check flag output
7	SBCS	Signal processor → µP	Interrupt signal to read out subcode Q data
8	MSD	µP ↔ Signal processor	Data line
9	RESET	Reset circuit → Signal processor	System reset
10	MCK	µP → Signal processor	Clock input
11	MLA	µP → Signal processor	Latch clock input
12-14	MODx	µP → Signal processor	Mode setting inputs ( 0, 1, 2 )
15	VDD2	-	+supply for data slicer and VCO
16	IREF	-	Current reference
17	HFD	Signal processor → µP	HF signal detect
18	LPF	-	PLL loop filter
19	HF	Servo processor → Signal processor	HF signal input
20	TLC	-	Output from slice level control
21	VSS2	-	Ground
22	C846	not connected	8.4672MHz clock output
23	C423	Signal processor → µP	4.2336MHz clock output
24	EST2	not connected	Error monitor output2
25	EST1	not connected	Error monitor output1
26	XI	X-Tal → Signal processor	Crystal oscillator input
27	XO	Signal processor → X-Tal	Crystal oscillator output
28	DOTX	not connected	Output of digital interface
29	DO1	Signal processor → DAC	Serial data output to DAC
30	DO2	not connected	Serial data output to Dual DAC
31	OKSEL	not connected	Crystal selector input: H=8MHz, L=16MHz
32	DSCK	Signal processor → DAC	Data shift clock
33	WDCK	Signal processor → DAC	Word clock
34	LROCK1	Signal processor → DAC	Left/Right clock
35-36	not used	-	Disc motor driving ( Pulse Width Modulation ) output1
37	PWM1	Signal processor → Motor driver	Left/Right clock
38	PWM2	Signal processor → Motor driver	Disc motor driving ( Pulse Width Modulation ) output2
39-41	not used	-	-
42	VSS1	GND	Digital system ground

**EXPLODED VIEW DIAGRAM - TAPE DECK**

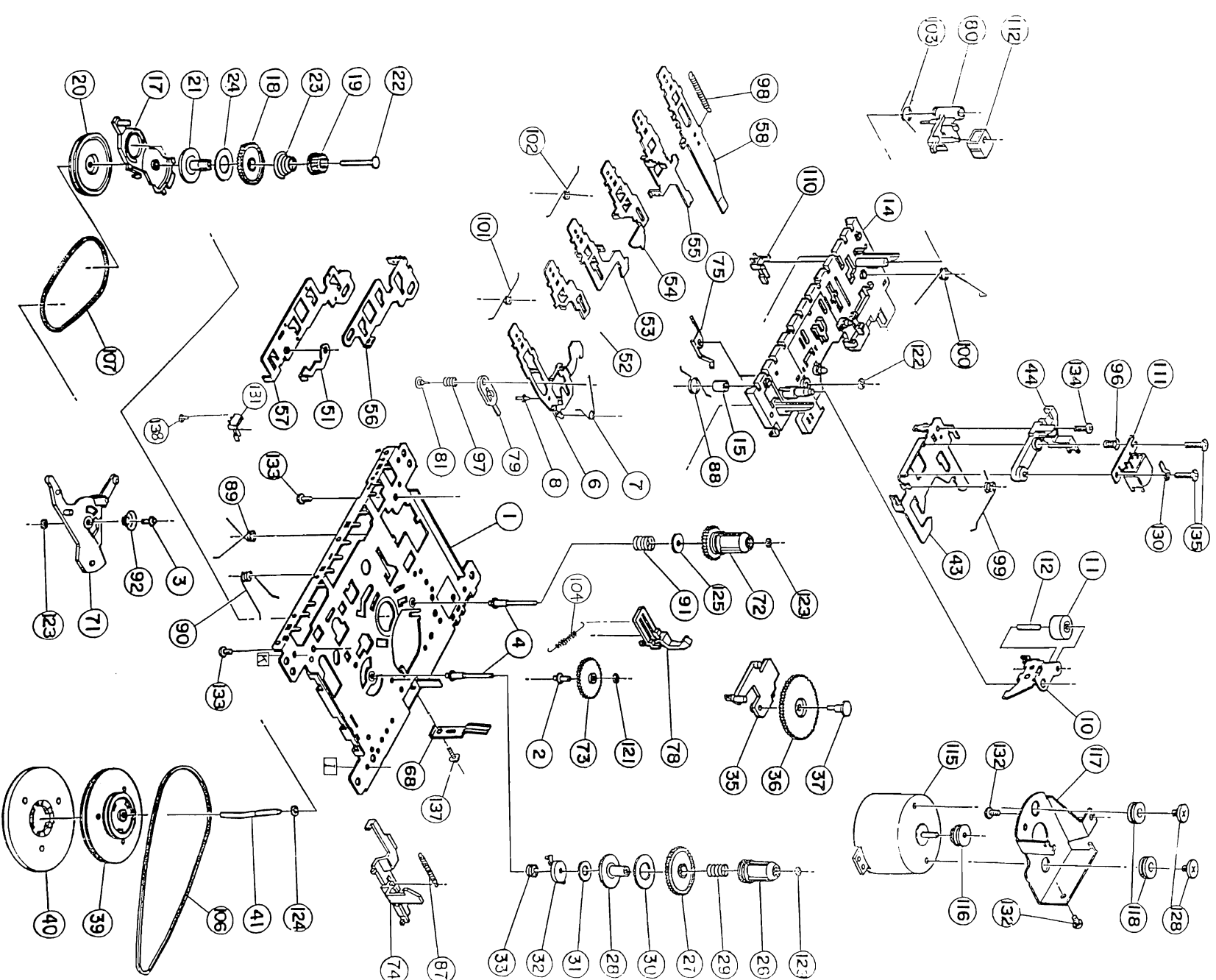

**EXPLODED VIEW DIAGRAM - CABINET**

401	4822 459 04629	Front Panel	448	4822 492 40854	Torsion Spring
402	4822 450 10364	Lens CD (Not for -/17)	449	4822 528 40208	Drum
402	4822 450 10365	Lens CD (For -/17)	451	4822 528 80907	Pulley Pom
403	4822 450 10361	Window LCD	452	4822 450 10322	Pointer
404	4822 450 10362	Cassette Door Lens	453	4822 529 10386	Damper Rubber (30 Deg)
406	4822 443 10733	Cassette Door	456	4822 529 10322	Damper Assy
407	4822 492 42709	Spring Door	457	4822 450 10363	Lens Tuning (For -/00/05)
408	4822 459 04631	Front Cabinet Assy	457	4822 450 10359	Lens Tuning (Not for -/00/05)
409	4822 410 11243	Button Set Search	458	4822 410 11126	Knob Tuning
411	4822 410 11242	Button Set Play	459	4822 402 10724	Bracket Handle
413	4822 402 10722	Bracket LCD	462	4822 492 11418	Spring CD
414	4822 410 11239	Cassette Knob	463	4822 426 10473	Cabinet Rear
416	4822 492 11061	Spring Recording	464	4822 265 20318	Socket Main (Not for -/17)
417	4822 402 10126	Lever Recording	464	4822 265 20706	Socket Main (For -/17)
418	4822 410 11237	Button Set Shuffle	466	4822 492 51733	Spring Compression
419	4822 529 10322	Damper Assy	467	4822 492 51961	Spring Compression
422	4822 402 10784	Bracket Sound Box	468	4822 290 80313	Contact Plate
423	4822 691 10612	Tape Deck Mechanism	469	4822 443 10655	Battery Door
428	4822 529 10387	Damper Rubber (40 Deg)	471	4822 303 14038	Telescopic Aerial
429	4822 410 11124	Knob DBB		4822 321 10249	Mains Cord (For -/00/01/11)
431	4822 410 11241	Knob IS		4822 321 10886	Mains Cord (For -/05/11H)
432	4822 410 11123	Knob Mode		4822 321 10954	Mains Cord (For -/10)
434	4822 402 10723	Lever Elect		4822 321 10882	Mains Cord (For -/17)
436	4822 492 11058	Spring Elect		4822 736 15477	Instr Manual (For -/01/10/11/11H)
437	4822 418 10272	Tray CD (For -/00/05)		4822 736 15482	Instr Manual (For -/00/05)
437	4822 418 10269	Tray CD (For -/01)		4822 736 15478	Instr Manual (For -/17)
437	4822 418 10269	Tray CD (For -/10)			
437	4822 418 10269	Tray CD (For -/11/11H)			
437	4822 418 10271	Tray CD (For -/17)			
438	4822 410 11132	Knob Volume			
439	4822 410 11128	Knob Open			
441	4822 535 60096	Disc			
443	4822 532 12798	Pressure Ring Assy			
446	4822 410 11238	Knob Band			
447	4822 464 10294	Frame Tuning			

Note : Only those parts mentioned in the list are normal service parts.

**EXPLODED VIEW DIAGRAM - TAPE DECK**

10	4822 528 70849	Pinch Roller Arm (B)	110	4822 278 90721	Leaf Switch
11	4822 528 70695	Pinch Roller Assy	111	4822 249 30218	MS18R-AKONI
74	4822 403 70968	Elect Hook (A)	112	4822 249 40306	E. Head
106	4822 358 31325	Main Belt 45.2 x 1.2	115	4822 361 21656	Motor EG-530AD-9B
107	4822 358 31124	Sub Belt 44.7 x 1.2	116	4822 528 81497	Motor Pulley

Note : Only those parts mentioned in the list are normal service parts.

EXPLODED VIEW DIAGRAM- CABINET

DIAL STRINGING

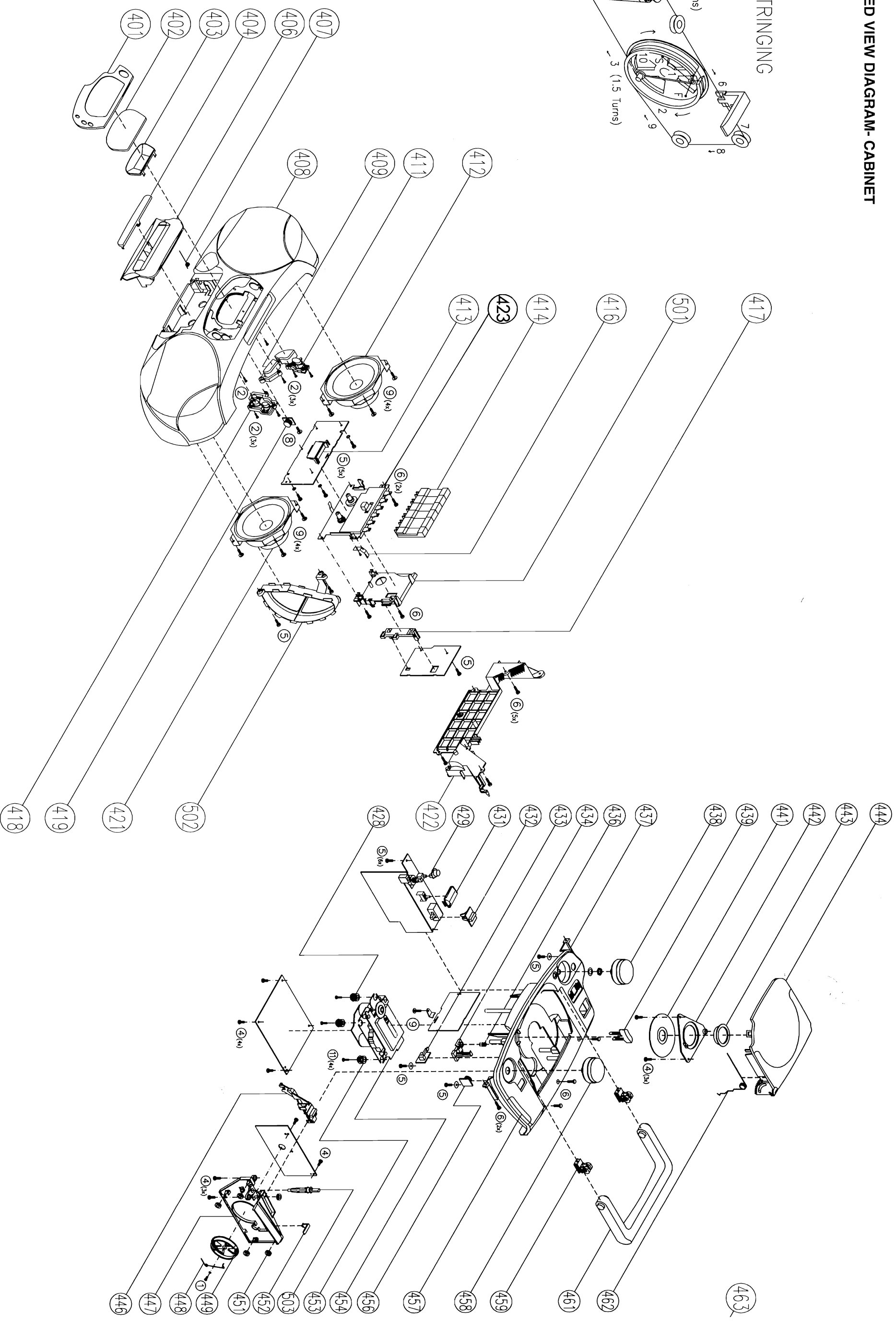
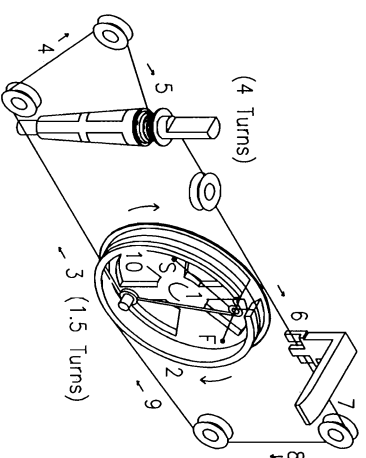

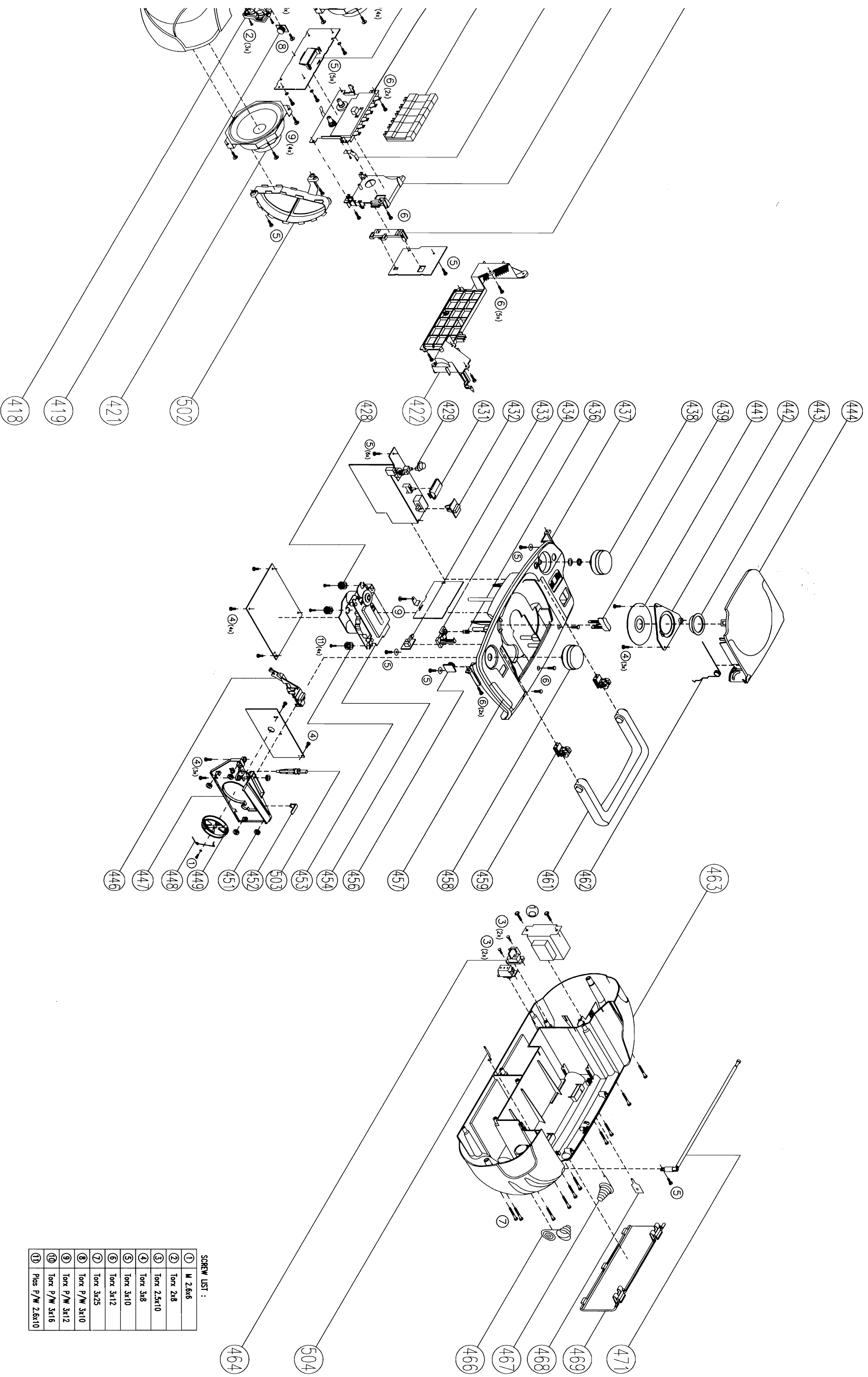

SCREW LIST :

①	M 2.6x6
②	Torx 2x8
③	Torx 2.5x10
④	Torx 3x8
⑤	Torx 3x10
⑥	Torx 3x12
⑦	Torx 3x25
⑧	Torx P/W 3x10
⑨	Torx P/W 3x12
⑩	Torx P/W 3x16
⑪	Plus P/W 2.5x10



## AUDIO BOARD

6V 50V	3411	4822 116 52244	15K	5%	0,5W
50V	3416	4822 116 52304	82K	5%	0,5W
50V	3516	4822 116 52269	3K3	5%	0,5W
63V	3517	4822 116 52269	3K3	5%	0,5W
63V	3518	4822 116 52235	1M	5%	0,5W
50V	3519	4822 116 52235	1M	5%	0,5W
50V	3522	4822 102 10447	Rot 50KB x 2		
50V	3529	4822 116 83863	1K	5%	0,5W
50V	3530	4822 116 83863	1K	5%	0,5W
63V	3576	4822 116 83883	470R	5%	0,5W
63V	3577	4822 116 83883	470R	5%	0,5W
	3578	4822 116 52238	12K	5%	0,5W
	3579	4822 116 52238	12K	5%	0,5W
	3580	4822 116 83872	220R	5%	0,5W
	3582	4822 116 52305	820K	5%	0,5W
0,33W	3583	4822 116 52305	820K	5%	0,5W
0,5W	3584	4822 116 52243	1K5	5%	0,5W
0,5W	3585	4822 116 52243	1K5	5%	0,5W
0,5W	3586	4822 116 52228	680R	5%	0,5W
0,5W	3587	4822 116 52228	680R	5%	0,5W
0,5W	3588	4822 116 52283	4K7	5%	0,5W
0,33W	3589	4822 116 52283	4K7	5%	0,5W
0,5W	3590	4822 116 52244	15K	5%	0,5W
0,5W	3591	4822 116 52244	15K	5%	0,5W
0,5W	3595	4822 116 83961	6K8	5%	0,5W
0,5W	3596	4822 116 83961	6K8	5%	0,5W
0,5W	3597	4822 116 52238	12K	5%	0,5W
0,5W	3598	4822 116 52238	12K	5%	0,5W
0,5W	3599	4822 116 52283	4K7	5%	0,5W
0,5W	3600	4822 116 52283	4K7	5%	0,5W
0,5W	3610	4822 116 83864	10K	5%	0,5W
0,5W	3611	4822 116 83864	10K	5%	0,5W
0,5W	3620	4822 116 52219	330R	5%	0,5W
0,5W	3621	4822 116 52219	330R	5%	0,5W
0,5W	3660	4822 116 83864	10K	5%	0,5W
0,5W	3661	4822 116 83864	10K	5%	0,5W

## AUDIO BOARD

5503	4822 157 51195	Coil 1µH 20%
6300	4822 130 31878	Diode 1N4003G
6301	4822 130 31878	Diode 1N4003G
6302	4822 130 31878	Diode 1N4003G
6303	4822 130 31878	Diode 1N4003G
6304	4822 130 32806	BZX79-F3V3
6305	4822 130 30621	Diode 1N4148
6402	4822 130 30621	Diode 1N4148
6403	4822 130 30621	Diode 1N4148
6404	4822 130 30621	Diode 1N4148
6405	4822 130 30621	Diode 1N4148
7250	4822 130 42231	Trans BCS57C
7251	4822 130 41327	Trans BC327-40
7252	4822 130 44503	Trans BCS47C
7253	4822 130 42231	Trans BCS57C
7254	4822 130 41327	Trans BC327-40
7300	4822 209 31544	IC TA8227P
7400	5322 130 44779	Trans BC338-40
7401	5322 130 44779	Trans BC338-40
7415	4822 130 44503	Trans BCS47C
7513	4822 130 44503	Trans BCS47C
7514	4822 130 44503	Trans BCS47C

### - MISCELLANEOUS -

1006	4822 240 10248	Loudspeaker 6W
1007	4822 240 10248	Loudspeaker 6W
1008	4822 146 10825	Transf (For -/00/0510)
1008	4822 146 10821	Transf (For -/01)
1008	4822 146 10821	Transf (For -/11/11H)



### - MISCELLANEOUS -



1008	4822 146 10822	Transf (For -/17)
1257	4822 267 31468	Phone Socket 3.5mm
1301	4822 277 21794	Volt Sel (For -/01)
1301	4822 277 21794	Volt Sel (For -/11/11H)
1302	4822 070 32002	Fuse 2A
1400	4822 277 30689	Slide Switch
1503	4822 276 12648	Push Switch
1507	4822 277 21698	Slide Switch
1800	4822 276 13625	Push Switch
	4822 280 10336	Loudspeaker Piezo
	4822 280 10336	Loudspeaker Piezo

Note : Only those parts mentioned in the list are normal service parts.



## TAPE DECK

		
2630	4822 126 13678	470µF 10V
2631	4822 124 41596	22µF 20% 50V
2632	4822 124 40242	1µF 20% 63V
2633	4822 124 40242	1µF 20% 63V
2634	4822 126 12878	1,5nF 10% 16V
2635	4822 126 12878	1,5nF 10% 16V
2636	5322 122 32311	470pF 10% 100V
2637	5322 122 32311	470pF 10% 100V
2638	4822 124 11958	47µF 20% 25V
2639	4822 124 11958	47µF 20% 25V
2640	4822 126 12787	330pF 10% Y5V 50V
2641	4822 126 12787	330pF 10% Y5V 50V
2642	4822 121 51304	10nF 10% 50V
2643	4822 121 51304	10nF 10% 50V
2644	4822 126 12339	2,2nF 10% Y5R
2645	4822 126 12339	2,2nF 10% Y5R
2646	5322 121 42386	100nF 5% 63V
2647	5322 121 42386	100nF 5% 63V
2648	4822 126 11167	22nF 20% 50V
2649	4822 126 11167	22nF 20% 50V
2650	4822 124 11958	47µF 20% 25V
2651	4822 124 11958	47µF 20% 25V
2652	4822 122 33197	1nF 10% 50V
2653	4822 122 33197	1nF 10% 50V
2654	4822 124 41596	22µF 20% 50V
2655	4822 122 33197	1nF 10% 50V
2656	4822 124 40242	1µF 20% 63V
2657	4822 121 51304	10nF 10% 50V
2658	4822 126 11714	4,7nF 20%
2659	4822 126 12147	22nF 10% Y5R 25V
		
3630	4822 116 83872	220R 5% 0,5W
3632	4822 116 83883	470R 5% 0,5W
3633	4822 116 83883	470R 5% 0,5W
3634	4822 116 83883	470R 5% 0,5W
3635	4822 116 83883	470R 5% 0,5W

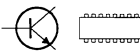
		
3636	4822 116 52197	56R 5% 0,5W
3637	4822 116 52197	56R 5% 0,5W
3638	4822 116 52271	33K 5% 0,5W
3639	4822 116 52271	33K 5% 0,5W
3640	4822 116 83961	6K8 5%
3641	4822 116 83961	6K8 5%
3642	4822 116 52252	180K 5% 0,5W
3643	4822 116 52252	180K 5% 0,5W
3644	4822 116 83864	10K 5% 0,5W
3645	4822 116 83864	10K 5% 0,5W
3646	4822 116 52244	15K 5% 0,5W
3647	4822 116 52244	15K 5% 0,5W
3648	4822 116 52238	12K 5% 0,5W
3649	4822 116 52238	12K 5% 0,5W
3650	4822 111 30893	4M7 5% 0,2W
3651	4822 116 52245	150K 5% 0,5W
3652	4822 116 52219	330R 5% 0,5W
3653	4822 116 52219	330R 5% 0,5W
3654	4822 116 52289	5K6 5% 0,5W
3655	4822 116 52289	5K6 5% 0,5W
3656	4822 116 83864	10K 5% 0,5W
3657	4822 116 52206	120R 5% 0,5W
3658	4822 116 52176	10R 5% 0,5W
3659	4822 116 52291	56K 5% 0,5W
		
5630	4822 156 20946	Osc Coil 100 KHz
		
7630	4822 130 40959	Trans BC547B
7700	4822 209 32918	IC AN7318S
- MISCELLANEOUS -		
1640	4822 277 11504	Push Switch

Note: Only those parts mentioned in the list are normal service parts.

# INCREDIBLE SOUND BOARD



2550	4822 126 11714	4,7nF	20%	
2551	4822 126 11714	4,7nF	20%	
2552	4822 122 10466	220pF	10%	50V
2553	4822 122 10466	220pF	10%	50V
2554	4822 122 33848	47pF	5%	SL 50V
2555	4822 122 33848	47pF	5%	SL 50V
2556	4822 122 33848	47pF	5%	SL 50V
2557	4822 122 33848	47pF	5%	SL 50V
2558	4822 122 33848	47pF	5%	SL 50V
2559	4822 122 33848	47pF	5%	SL 50V
2560	4822 121 51379	82nF	5%	63V
2561	4822 121 51379	82nF	5%	63V
2562	4822 121 51387	10nF	20%	16V
2563	4822 121 51387	10nF	20%	16V
2564	4822 124 40246	4,7µF	20%	63V
2565	4822 124 40246	4,7µF	20%	63V
2566	4822 126 12339	2,2nF	10%	Y5R
2567	4822 126 12339	2,2nF	10%	Y5R
2568	4822 124 11958	47µF	20%	25V
2569	4822 124 11958	47µF	20%	25V



3550	4822 116 52234	100K	5%	0,5W
3551	4822 116 52234	100K	5%	0,5W
3552	4822 116 52234	100K	5%	0,5W
3553	4822 116 52234	100K	5%	0,5W
3554	4822 116 83878	270K	5%	0,5W
3555	4822 116 83878	270K	5%	0,5W
3556	4822 116 52234	100K	5%	0,5W
3557	4822 116 52234	100K	5%	0,5W
3558	4822 116 83884	47K	5%	0,5W
3559	4822 116 83884	47K	5%	0,5W
3560	4822 116 52291	56K	5%	0,5W
3561	4822 116 52291	56K	5%	0,5W
3562	4822 116 52245	150K	5%	0,5W
3563	4822 116 52245	150K	5%	0,5W
3564	4822 116 52234	100K	5%	0,5W

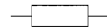

3565	4822 116 52234	100K	5%	0,5W
3566	4822 116 83863	1K	5%	0,5W
3567	4822 116 83863	1K	5%	0,5W
3568	4822 116 83863	1K	5%	0,5W
3569	4822 116 83863	1K	5%	0,5W
3570	4822 116 52234	100K	5%	0,5W
3571	4822 116 52234	100K	5%	0,5W
3572	4822 116 52256	2K2	5%	0,5W
3573	4822 116 52256	2K2	5%	0,5W
3574	4822 116 52222	390R	5%	0,5W
3575	4822 116 52222	390R	5%	0,5W
3576	4822 116 52304	82K	5%	0,5W
3577	4822 116 52304	82K	5%	0,5W
3578	4822 116 52257	22K	5%	0,5W
3579	4822 116 52257	22K	5%	0,5W
3580	4822 116 83864	10K	5%	0,5W
3581	4822 116 83864	10K	5%	0,5W
3582	4822 116 52283	4K7	5%	0,5W
3583	4822 116 52283	4K7	5%	0,5W
3584	4822 116 52175	100K	5%	0,5W



7550	4822 209 63709	IC LM324DTR
------	----------------	-------------

Note : Only those parts mentioned in the list are normal service parts.



2802	4822 126 12785	47nF +80-20% 50V
2803	4822 126 11585	47nF +80-20% 50V
2804	4822 126 12878	1,5nF 10% 16V
2805	4822 121 51412	560nF 10% 50V
2806	4822 122 33519	470pF 10% 50V
2807	4822 122 33191	18pF 5% 50V
2808	4822 124 22263	220µF 20% 25V
2809	4822 124 40242	1µF 20% 50V
2810	4822 124 40242	1µF 20% 50V
2811	4822 122 33849	150pF 10% 50V
2812	4822 122 33849	150pF 10% 50V
2813	4822 126 12339	2,2nF 10% 16V
2814	4822 126 13677	39pF 5% 50V
2815	4822 126 12882	100nF 8.2% 50V
2816	4822 124 41407	0,47µF 20% 50V
2817	4822 121 42687	3,3nF 10% 50V
2818	4822 124 40242	1µF 20% 50V
2819	5322 121 42386	100nF 10% 50V
2820	4822 124 40746	0,22µF 20% 50V
2821	4822 124 41579	10µF 20% 50V
2822	4822 122 10167	22nF 30% 50V
2823	4822 124 40246	4,7µF 20% 50V
2824	4822 124 41407	0,47µF 20% 50V
2825	4822 122 10462	15pF 5% NP0
2826	4822 124 41407	0,47µF 20% 50V
2827	4822 124 40433	47µF 20% 25V
2828	4822 124 41579	10µF 20% 50V
2829	5322 121 42489	33nF 10% 50V
2830	4822 122 10319	82pF 10% 50V
2831	4822 121 41856	22nF 10% 50V
2832	4822 124 41576	2,2µF 20% 50V
2833	4822 124 40433	47µF 20% 25V
2834	4822 126 12882	100nF +80-20% 50V
2835	4822 126 12882	100nF +80-20% 50V
2836	4822 124 80791	470µF 20% 16V
2837	4822 126 11585	22nF +80-20% 25V
2838	4822 126 12882	100nF +80-20% 50V
2839	4822 126 12882	100nF +80-20% 50V
2841	4822 122 33195	100pF 10% 50V
2842	4822 124 40849	330µF 20% 16V



2843	4822 126 13098	5,6nF 20% 16V
2844	4822 122 10466	220pF 10% 50V
2846	4822 122 33519	470pF 10% 50V
2848	4822 122 33519	470pF 10% 50V
2849	4822 122 10466	220pF 10% 50V
2860	4822 124 40433	47µF 20% 25V





3801	4822 052 10478	4R7 5% 0,33W
3802	4822 116 52252	180K 5% 0,16W
3803	4822 111 50499	3M3 5%
3805	4822 116 83884	47K 5% 0,16W
3806	4822 116 52256	2K2 5% 0,16W
3807	4822 116 52271	33K 5% 0,16W
3808	4822 116 52263	2K7 5% 0,16W
3809	4822 116 83884	47K 5% 0,16W
3810	4822 116 52257	22K 5% 0,16W
3811	4822 116 52257	22K 5% 0,16W
3812	4822 116 52257	22K 5% 0,16W
3815	4822 050 11002	1K 5% 0,16W
3816	4822 050 11002	1K 5% 0,16W
3817	4822 116 83883	470R 5% 0,16W
3818	4822 116 83883	470R 5% 0,16W
3819	4822 117 11825	1M5 5%
3820	4822 116 52252	180K 5% 0,16W
3821	4822 116 52243	1K5 5% 0,16W
3822	4822 116 52264	27K 5% 0,16W
3823	4822 116 52234	100K 5% 0,16W
3824	4822 116 83868	150R 5% 0,16W
3826	4822 116 83961	6K8 5% 0,16W
3827	4822 116 52243	1K5 5% 0,16W
3828	4822 116 83864	10K 5% 0,16W
3829	4822 116 52271	33K 5% 0,16W
3830	4822 116 52244	15K 5% 0,16W
3831	4822 116 52251	18K 5% 0,16W
3832	4822 116 52222	390R 5% 0,16W
3833	4822 116 52264	27K 5% 0,16W
3835	4822 116 52184	18R 5% 0,16W

3836
3837
3838
3839
3840
3841
3842
3844
3845
3846
3847
3848
3849
3850
3851
3852
3853
3854
3855
3856
3857
3858
3859
3860
3870
3871
3880
3881
3882
3883
3884
3886
3890
3891
3892
3893
3894
3895
3896
3897

CD 97

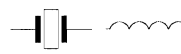
		
3836	4822 050 11002	1K 5% 0,16W
3837	4822 111 30893	4M7 5%
3838	4822 11652234	100K 5% 0,16W
3839	4822 116 52235	1M 5% 0,16W
3840	4822 050 11002	1K 5% 0,16W
3841	4822 116 52298	680K 5% 0,16W
3842	4822 116 52297	68K 5% 0,16W
3844	4822 116 52291	56K 5% 0,16W
3845	4822 116 52298	680K 5% 0,16W
3846	4822 050 11002	1K 5% 0,16W
3847	4822 116 52298	680K 5% 0,16W
3848	4822 116 52251	18K 5% 0,16W
3849	4822 052 10478	4R7 5%
3850	4822 116 52251	18K 5% 0,16W
3851	4822 116 52244	15K 5% 0,16W
3852	4822 116 83883	470R 5% 0,16W
3853	4822 116 52251	18K 5% 0,16W
3854	4822 116 52243	1K5 5% 0,16W
3855	4822 116 83882	29K 5% 0,16W
3856	4822 116 52303	8K2 5% 0,16W
3857	4822 116 52269	3K3 5% 0,16W
3858	4822 116 80176	1R 5% 0,16W
3859	4822 116 83864	10K 5% 0,16W
3860	4822 116 52207	1K2 5% 0,16W
3870	4822 052 10478	4R7 5%
3871	4822 116 52283	4K7 5% 0,5W
3880	4822 050 11002	1K 5% 0,16W
3881	4822 050 11002	1K 5% 0,16W
3882	4822 050 11002	1K 5% 0,16W
3883	4822 050 11002	1K 5% 0,16W
3884	4822 116 83882	39K 5% 0,16W
3886	4822 116 52235	1M 5% 0,16W
3890	4822 050 11002	1K 5% 0,16W
3891	4822 050 11002	1K 5% 0,16W
3892	4822 050 11002	1K 5% 0,16W
3893	4822 050 11002	1K 5% 0,16W
3894	4822 050 11002	1K 5% 0,16W
3895	4822 050 11002	1K 5% 0,16W
3896	4822 116 52256	2K2 5% 0,16W
3897	4822 116 52256	2K2 5% 0,16W

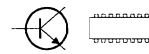
		
3898	4822 116 52256	2K2 5% 0,16W
3899	4822 050 11002	1K 5% 0,16W
		
5000	4822 526 10494	Ind Fxd 100MHz
5010	4822 526 10494	Ind Fxd 100MHz
5020	4822 526 10494	Ind Fxd 100MHz
5030	4822 526 10494	Ind Fxd 100MHz
5040	4822 526 10494	Ind Fxd 100MHz
5050	4822 526 10494	Ind Fxd 100MHz
5060	4822 157 50964	Coil 100µH 15%
5803	4822 242 73557	Filter 8MHz467
		
6001	4822 130 30621	Diode 1N4148
		
7801	4822 209 13703	IC M65821FP
7802	4822 209 32421	IC TDA1311A
7803	4822 209 90496	IC M62475FP
7804	5322 130 60068	Trans BC558C
7805	4822 209 32852	IC TDA7073A
7806	4822 209 32852	IC TDA7073A
- MISCELLANEOUS -		
1802	4822 265 10925	Connector
8000	4822 265 10926	Connector

Note : Only those parts mentioned in the list are normal service parts.

## FRONT BOARD



2401	4822 124 11959	100µF	20%	10V
2402	4822 124 40242	1µF	20%	63V
2464	4822 122 10466	220pF	10%	50V
2465	4822 122 10466	220pF	10%	50V

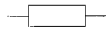

3401	4822 116 52175	100R	5%	0,5W
3402	4822 116 52234	100K	5%	0,5W
3403	4822 116 52244	15K	5%	0,5W
3404	4822 116 83883	470R	5%	0,5W
3405	4822 116 52238	12K	5%	0,5W
3406	4822 116 52276	3K9	5%	0,5W
3407	4822 116 52243	1K5	5%	0,5W
3408	4822 116 52226	560R	5%	0,5W
3410	4822 116 83961	6K8	5%	0,5W
3411	4822 116 52238	12K	5%	0,5W
3412	4822 116 52257	22K	5%	0,5W
3414	4822 116 83961	6K8	5%	0,5W
3415	4822 116 52238	12K	5%	0,5W
3416	4822 116 52257	22K	5%	0,5W
3451	4822 116 52283	4K7	5%	0,5W
3452	4822 116 52283	4K7	5%	0,5W
3453	4822 116 52283	4K7	5%	0,5W
3454	4822 116 52283	4K7	5%	0,5W
3455	4822 116 52283	4K7	5%	0,5W
3456	4822 116 52283	4K7	5%	0,5W
3457	4822 116 52283	4K7	5%	0,5W
3458	4822 116 52283	4K7	5%	0,5W
3459	4822 116 52283	4K7	5%	0,5W
3460	4822 116 52283	4K7	5%	0,5W
3461	4822 116 52269	3K3	5%	0,5W
3462	4822 116 52243	1K5	5%	0,5W
3463	4822 116 52283	4K7	5%	0,5W
3464	4822 116 52283	4K7	5%	0,5W
3465	4822 116 52283	4K7	5%	0,5W
3466	4822 116 52243	1K5	5%	0,5W
3467	4822 116 52243	1K5	5%	0,5W
3468	4822 116 52283	4K7	5%	0,5W
3469	4822 116 52231	820R	5%	0,5W
3470	4822 116 52231	820R	5%	0,5W
3471	4822 116 52283	4K7	5%	0,5W

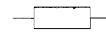

3472	4822 116 52231	820R	5%	0,5W
3473	4822 116 52269	3K3	5%	0,5W
3474	4822 116 52283	4K7	5%	0,5W
3475	4822 116 52283	4K7	5%	0,5W
3479	4822 116 52283	4K7	5%	0,5W

3480	4822 116 52257	22K	5%	0,5W
3481	4822 116 52257	22K	5%	0,5W
3482	4822 116 52257	22K	5%	0,5W
3483	4822 116 52257	22K	5%	0,5W
3484	4822 116 52264	27K	5%	0,5W
3485	4822 116 52264	27K	5%	0,5W

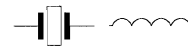

5401	4822 242 73769	Filter	CST4,19MGW
5402	4822 156 21721	Inductor	2,2µH 10%
5403	4822 157 52333	Inductor	100µH 10%



6402	4822 130 30621	Diode	1N4148
6403	4822 130 30621	Diode	1N4148
6404	4822 130 31554	Diode	BZX79-B4V3



7401	4822 209 15568	IC	TMP47C422F
7402	4822 130 44503	Trans	BC547C
7403	4822 130 40959	Trans	BC547B

### - MISCELLANEOUS -

1401	4822 135 00124	LCD	Display
1410	4822 276 13114	Tact	Switch
1411	4822 276 13114	Tact	Switch
1412	4822 276 13114	Tact	Switch
1413	4822 276 13114	Tact	Switch
1415	4822 276 13114	Tact	Switch
1416	4822 276 13114	Tact	Switch
1417	4822 276 13114	Tact	Switch

Note : Only those parts mentioned in the list are normal service parts.

### ATM 3



2101	4822 122 33195	100pF 10% 50V
2102	4822 126 12812	47pF 5% 50V
2103	4822 124 40248	10µF 20% 63V
2104	4822 124 40248	10µF 20% 63V
2105	4822 126 12112	22pF 5% N220 50V
2106	4822 125 50681	Var Capacitor
2108	4822 122 32147	22pF 2% N470 100V
2109	4822 122 31821	3,3pF 0,25% 100V
2110	4822 126 12284	5,6pF 0,5% N1500 50V
2110	4822 126 12229	8,2pF N750 50V
2112	4822 124 41397	47µF 20% 25V
2113	4822 126 13581	0,22µF 20% 50V
2114	4822 126 12787	330pF 10% Y5V 50V
2115	4822 124 40246	4,7µF 20% 63V
2116	4822 126 12077	15nF 10% 25V
2116	4822 126 12147	22nF 10% Y5R 25V
2117	4822 124 40242	1µF 20% 63V
2118	4822 124 40242	1µF 20% 63V
2119	4822 126 12077	15nF 10% 25V
2119	4822 126 12147	22nF 10% Y5R 25V
2120	4822 124 40242	1µF 20% 63V
2121	4822 124 40239	0,47µF 20% 63V
2122	4822 124 40239	0,47µF 20% 63V
2125	β 4822 126 12826	120pF 50% N750 50V
2126	β 4822 125 50045	1p8-22p 250V
2150	β 4822 125 50045	1p8-22p 250V



3101	4822 100 20167	50K 30% 0,1W
3102	4822 116 52297	68K 5% 0,5W
3104	4822 116 52256	2K2 5% 0,5W
3108	4822 116 52191	33R 5% 0,5W
3108	4822 116 52195	47R 5% 0,5W
3109	4822 116 52234	100K 5% 0,5W
3110	4822 116 52234	100K 5% 0,5W
3111	α 4822 116 83863	1K 5% 0,5W
3113	4822 116 52252	180K 5% 0,5W

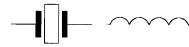

5101	4822 157 70513	FM-RF Coil
5101	4822 157 53789	FM-RF Coil
5104	4822 156 30947	FM-Osc Coil
5105	4822 157 71145	Coil 270µH
5106	4822 157 70499	AM-IF Filter 468KHz
5107	4822 242 81154	Filter KMFC5058-Z
5108	4822 156 11146	AM-IF Filter 468KHz
5109	β 4822 157 71144	Coil 280µH
5111	4822 156 21738	Coil F7BRS-12645X
5112	β 4822 156 21739	Coil F126ANS-8402Y



6101	4822 130 30621	Diode 1N4148
6102	4822 130 30621	Diode 1N4148



7101	4822 209 32746	IC TEA5711T/N2
------	----------------	----------------

#### - MISCELLANEOUS -

1100	β 4822 277 30933	Switch FM/LW/MW
1101	α 4822 277 21698	Switch FM/AM

α for FM/MW only  
β for FM/MW/LW only

Note : Only those parts mentioned in the list are normal service parts.