

Service  
Service  
Service

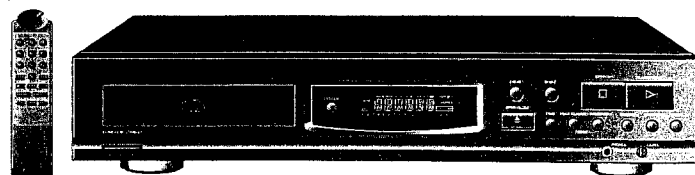

# Service Manual

For CD721/00/01, please refer to Service Manual CD720/00B - 4822 725 24056 *482137*  
 For CD721/05, please refer to Service Manual CD720/05B - 4822 725 24056  
 with the following differences :

## 1. Mechanical Changes:

1	4822 444 40831	Cabinet front
8	4822 410 63803	Button set
15	4822 450 62475	Window display
65	4822 444 30511	Cover front CD
151	4822 444 61045	Cover - /01 only
251	4822 462 42206	Foot
252	4822 462 42206	Foot
253	4822 462 42206	Foot
254	4822 462 42206	Foot
308	4822 321 22832	Cinch cable assy - /01 only
365	4822 218 10538	Remote control
	4822 736 22461	DFU (multi language)
	4822 736 22467	DFU (GB-F-E-C) - /01 only

Delete : 283 - /01 only

## 2. Electrical Changes:

3708 change to 3725	4822 050 11002	1k 5% 0.4W
9062 change to 3726	4822 050 11002	1k 5%
9034 change to 3727	4822 050 11002	1k 5%
9069 change to 2506	4822 126 12882	100nF +80%-20% 50V

Delete : 2109, 2112, 2118, 3112, 3116, 3707.

Add	2113	4822 122 33191	22pF 5% 50V
	5500	4822 146 21796	Transformer - /01 only



# Service

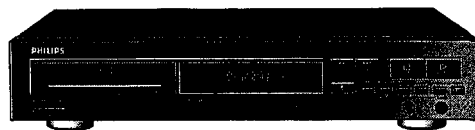

# Service Manual

TABLE OF CONTENTS	PAGE
1. Technical specifications	2
2. Instructions for use	3
3. Warnings	9
4. Servicing hints	10
5. Dismantling instructions	11
6. Service test program	12
7. CDM12 start up diagram	13
8. Faultfinding diagram CDM12	14
9. Faultfinding diagram decoder part	20
10. Specifications measurement	21
11. Abbreviations	22
12. Block diagram	23
13. Wiring diagram	24
14. Circuit diagrams and printed boards	
14.1. Power supply	25
14.2. Servo circuit diagram	26
14.3. Decoder circuit diagram	27
14.4. DAC circuit diagram	28
14.5. Main panel component side	29
14.6. Main panel solder side	30
14.7. Control & Display & Headphone	31
15. Loader	32
16. Mechanical Partslist	33
17. Exploded view	33
18. Electrical partslist	34



Service  
Service  
Service

# Circuit Description

## CONTENTS

### 1. Block diagrams

1.1. Block diagram CD710/CD720 .....	1-1
1.2. Block diagram CD740/CD911/CD921 .....	1-2
1.3. Block diagram CD750 .....	1-3

### 2. Circuit diagrams

2.1. Decoder circuit diagram .....	2-1
2.2. DAC circuit diagram CD710/CD720 .....	2-2
2.3. DAC circuit diagram CD740/CD911/CD921 .....	2-3
2.4. DAC circuit diagram CD750 .....	2-4

### 3. CD6 decoder SAA7345

3.1. General description .....	3-1
3.2. Block diagram .....	3-1
3.3. Pin description .....	3-2
3.4. Functional description .....	3-3

### 4. Stereo continuous calibration DAC TDA1545

4.1. General description .....	4-1
4.2. Block diagram .....	4-1
4.3. Pin description .....	4-1
4.4. Functional description .....	4-2

### 5. BCC-DAC TDA1549

5.1. General description .....	5-1
5.2. Block diagram .....	5-1
5.3. Pin description .....	5-2
5.4. Functional description .....	5-3



## TECHNICAL SPECIFICATIONS

### General

1.Mains voltage	/00B	: 230V (+6 -10%)
	/05B	: 240V ( $\pm 10\%$ )
	/01B	: 110V-127V/220V-240V
2.Mains frequency		: 50-60 Hz
3.Mains voltage selection only	/01B	: Voltage selector 2 positions
4.Power consumption mains	standby	: < 3W
	operated	: < 10W

### Remote Control(only CD720)

Internal: RC5

### Line output

1.Number of channels		: 2
2.Output voltage		: 2 Vrms $\pm$ 3 dB
3.Output resistance		: 1 k $\Omega$
4.Dynamic range (-60 dB)		: min. 84 dB from 20 Hz to 20 kHz
5.Unbalance left-right		: max. 1 dB
6.Channel separation		: min. 82 dB from 20 Hz to 20 kHz
7.Signal to noise ratio		: min. 83 dB from 20 Hz to 20 kHz
8.Total harmonic distortion + noise		: min. 70 dB from 20 Hz to 20 kHz
9.Frequency response		: max. $\pm$ 0.5 dB from 20 Hz to 20 kHz
10.Phase non-linearity		: max 7.0° from 20 Hz to 16 kHz
11.Automatic switched deemphasis with time constant 15/50 $\mu$ s		
12.Out-band attenuation		: min. 35 dB (above 40 kHz)

### Variable headphone(only CD720) (low end)

1.Output voltage		: max. 5 Vrms $\pm$ 3dB
2.Unbalance left-right		: max. $\pm$ 1.2 dB
3.Output resistance		: 120 $\Omega$
4.Load impedance range		: 30 $\Omega$ to 600 $\Omega$
5.Output power		: 0 to 30 mW into 30 $\Omega$ load
		: 0 to 50 mW into 150 $\Omega$ load
		: 0 to 30 mW into 600 $\Omega$ load

Audio specs in case of 600  $\Omega$  load at 4 Vrms voltage output

6.Signal to noise ratio		: min. 80 dB
7.Dynamic range		: min. 70 dB (20 Hz -20 kHz)
8.Total harmonic distortion		: min. 60 dB (20 Hz - 20 kHz)
9.Channel separation		: min. 70 dB (1 kHz)
		: min. 65 dB (31.5 Hz - 16 kHz)

### Dimensions and weight

1.Apparatus tray closed		: WxDxH 435 x 260 x 74/90 mm
2.Apparatus tray open		: WxDxH 435 x 405 x 74/90 mm
3.Weight		: 3 kg

### Optical read-out system

1.Laser type		: Semiconductor AlGaAs
2.Wavelength		: 780 nm $\pm$ 20 nm
3.Light output (c.w.)		: max. 0.5 mW

## CONTENTS

	PAGE
<b>INSTALLATION</b> .....	<b>5</b>
Fitting a mains plug ( <i>U.K. only</i> ) .....	5
Power supply setting .....	5
Connections .....	5
Connecting headphones ( <i>CD720 only</i> ) .....	5
<b>FUNCTIONAL OVERVIEW</b> .....	<b>6-7</b>
Front of player .....	6
Remote control ( <i>CD720 only</i> ) .....	6
Display .....	7
Display messages .....	7
<b>PLAYBACK</b> .....	<b>8-10</b>
Normal playback .....	8
Selecting another track .....	9
Searching for a passage .....	9
Starting with a particular track .....	9
Playing the CD in random order .....	9
Repeating play .....	9
Calling up other time information .....	9
Searching the loudest passage .....	10
Setting the fade-in and fade-out time .....	10
Scanning a CD ( <i>CD720 only</i> ) .....	10
Adjusting the sound level ( <i>CD720 only</i> ) .....	10
<b>PROGRAMMING</b> .....	<b>11</b>
Storing a programme .....	11
Playing the programme .....	11
Erasing a programme .....	11
<b>ADDITIONAL INFORMATION</b> .....	<b>12</b>
Maintenance .....	12
Recycling .....	12
Technical data .....	12
<b>Troubleshooting</b> .....	<b>13</b>

### FITTING A MAINS PLUG (*U.K. only*)

This apparatus is fitted with an approved moulded 13 Amp plug. To change a fuse in this type of plug proceed as follows:

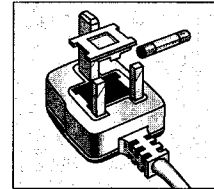

- Remove fuse cover and fuse.
- Fix new fuse which should be a BS1362 5A, A.S.T.A. or BSI approved type.
- Refit the fuse cover.

If the fitted plug is not suitable for your socket outlets, it should be cut off and an appropriate plug fitted in its place.

If the mains plug contains a fuse, this should have a value of **5A**. If a plug without a fuse is used, the fuse at the distribution board should not be greater than **5A**.

#### NOTE

*The severed plug must be disposed to avoid a possible shock hazard should it be inserted into a 13A socket elsewhere.*

### HOW TO CONNECT A PLUG

The wires in the mains lead are coloured in accordance with the following code: BLUE – "NEUTRAL" ("N") and BROWN – "LIVE" ("L"). As these colours may not correspond with the colour markings identifying the terminals in your plug, proceed as follows:

- The BLUE wire must be connected to the terminal which is marked with the letter "N" or coloured BLACK.
- The BROWN wire must be connected to the terminal which is marked with the letter "L" or coloured RED.
- Do *not* connect either wires to the earth terminal in the plug which is marked by the letter "E" or by the safety earth symbol or coloured green or green-and-yellow.

Before replacing the plug cover, make certain that the cordgrip is clamped over the sheath of the lead – not simply over the two wires.

## INSTALLATION

### POWER SUPPLY SETTING

- Check that the type plate at the bottom of your player indicates the correct supply voltage.
- If your mains supply voltage is different, consult your dealer or our Service Organisation.
- *Certain versions of this player are equipped with a voltage selector at the bottom of the player which enables you to set the player to the correct mains voltage yourself.*

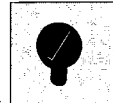

*Position 120 V: for all mains voltages between 110V and 127 V.*

*Position 230 V: for all mains voltages between 220V and 240 V.*

### CONNECTIONS

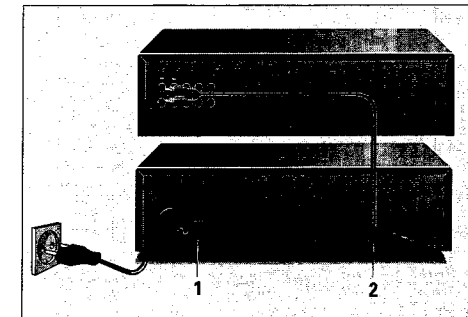

#### 1 Mains connection

- Connect the mains lead to your mains supply.

#### 2 Connecting cable to the amplifier

- Insert the red plug (right channel) and the white plug (left channel) into the corresponding sockets of the CD or AUX input of your amplifier. You can also use the TUNER or TAPE IN-connection, but *never* the PHONO input!

### CONNECTING HEADPHONES (*CD720 only*)

- Connect headphones with a 6.3 mm jack plug to the PHONES socket **11**.
- The sound level is adjusted with the LEVEL control **13**.

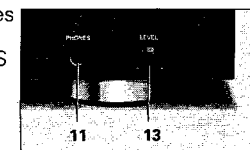

## FUNCTIONAL OVERVIEW

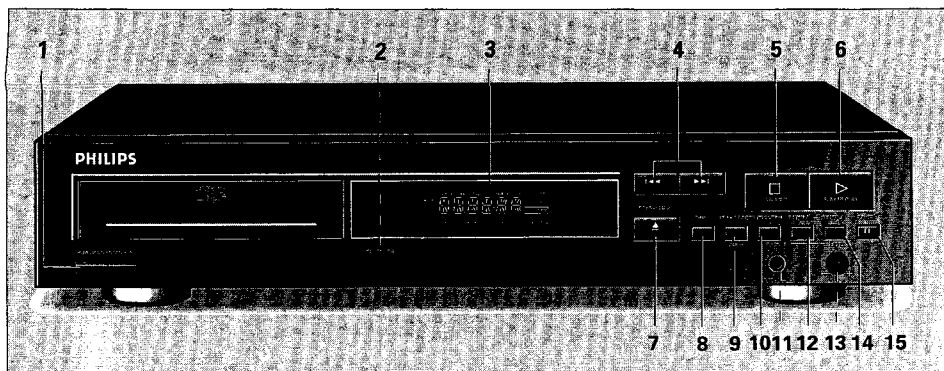

### FRONT OF PLAYER

- 1 POWER ON/STANDBY** – Switching on and off.
- 2 Infrared (IR) SENSOR (CD720 only)**  
Receives the signals from the remote control.
- 3 Display** – Informs you about the functioning of the player.
- 4** ◀ and ▶  
– Selecting another track.  
– Selecting a track to start play with.  
– Fast search to a particular passage during play.
- 5 STOP/CP**  
– Stopping play.  
– Erasing a programme (CP = Clear Programme).
- 6 PLAY/REPLAY**  
– Starting play.  
– Returning to the beginning of a track.
- 7 OPEN/CLOSE** – Opening and closing the CD compartment. The compartment also closes when the front is pressed briefly.
- 8 TIME** – Selecting the time information you want to see.
- 9 PEAK SEARCH** – Searching the loudest passage (peak) on a CD or in a programme when making a tape recording.  
**FADER** – Fading in and out during play.
- 10 PROGRAM**  
– Opening the memory when compiling a programme.  
– Storing tracks in a programme.
- 11 PHONES (CD720 only)**  
Connecting headphones.
- 12 REPEAT** – Repeating play.
- 13 LEVEL (CD720 only)** – Adjusting the volume when listening with headphones.

- 14 SHUFFLE** – Playback in random order.
- 15 PAUSE** – Interrupting play.

### REMOTE CONTROL (CD720 only)

- The life of the batteries of the remote control is around one year. For replacement only use batteries of the type RO3, UM4 or AAA.
- The buttons on the remote control have the same functions as the corresponding ones on the player.
- Extra buttons:
- 16 SCAN** – Automatically playing the beginning of each track.
- 17 VOLUME +** – Adjusting the sound level when the player is connected to an amplifier or HiFi system without its own remote control.

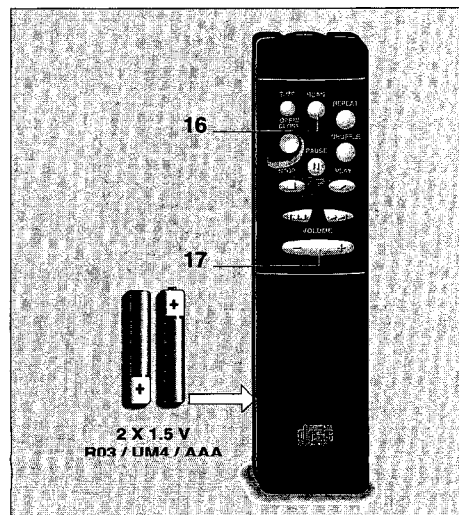

### DISPLAY



#### PAUSE

Lights up when play is interrupted.

⏸ (CD720 only)

Lights up when the player receives a command from the remote control.

**TRACK** – Indicates:

- what track is being played;
- the number of tracks on the CD or in a programme.

**PEAK**

– Flashes when the loudest passage (peak) on a CD or in a programme is being searched.

– Lights up when the loudest passage (peak) has been found.

**TRACK TIME**

Indicates the elapsed playing time of the track being played.

**REM(aining) TRACK TIME**

Indicates the remaining playing time of the track being played.

**TOTAL REM(aining) TIME**

Indicates the remaining playing time of the CD or a programme.

**TOTAL TIME**

Indicates the total playing time of the CD or a programme.

**REPEAT**

Lights up when you repeat a CD or a programme.

**REPEAT 1**

Lights up when you repeat a track.

**SHUFFLE**

Lights up when the tracks are played in random order.

**PROGRAM**

- Flashes when a programme is being compiled.
- Lights up when a programme has been stored in the player memory.

**1-15 track number indicator**

Shows the number of tracks on the CD.

**+**

Lights up when there are more than 15 tracks on the CD.

## FUNCTIONAL OVERVIEW

### DISPLAY MESSAGES



Lights up when the CD's contents list is being scanned.



Lights up when there is no CD in the CD compartment.



Scrolls on the display when insert a non audio CD (CD-ROM, CD-I or CDV).



Scrolls on the display if you select a non-existent track number.



Scrolls on the display if you try to activate a function for which you must first start play.



Scrolls on the display if you try to activate a function for which you must first stop play.

# PLAYBACK

## NORMAL PLAYBACK (PLAY/REPLAY)

**NOTE!** Use only audio CDs; no CD-ROM, CD-I or CDV.

- Press POWER ON/STANDBY **1** to switch the player on.
- Open the CD compartment by pressing OPEN/CLOSE **7**.
  - OPEN lights up.
- Insert an audio CD, **printed side up**, and close the compartment by pressing OPEN/CLOSE **7**.

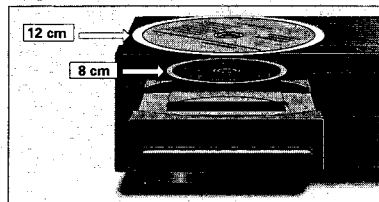
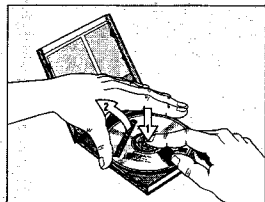

- CLOSE lights up, followed by READ. The number of tracks and the playing time of the CD are shown on the display.

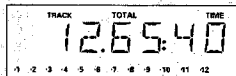

- Press PLAY/REPLAY **6** to start play. You can also press PLAY/REPLAY immediately after inserting the CD; the compartment then closes automatically. You can also close the CD compartment by pressing its front; playback will then start automatically.

– The number indicator shows how many tracks are on the CD; when a track has been played its number disappears.

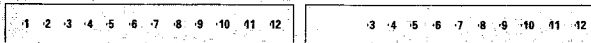

- The track being played is always shown under TRACK and its elapsed playing time is shown under TRACK TIME.

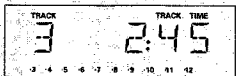

- Play will stop after the last track.
- Press POWER ON/STANDBY **1** to switch the player off.

You can interrupt playback by pressing PAUSE **15**; PAUSE then lights up. Press PLAY/REPLAY **6** to restart; if you *first* press PAUSE again and *then* PLAY/REPLAY, the current track starts again from the beginning.

You can also restart play by pressing SCAN **16** (on the remote control - **CD720 only**) or SHUFFLE **14**.

If you press PLAY/REPLAY during play, the current track starts again from the beginning.

You can stop playback by pressing STOP/CP **5** or OPEN/CLOSE **7**.

# PLAYBACK

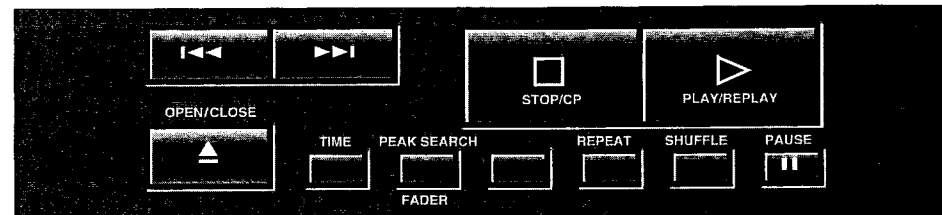

## SELECTING ANOTHER TRACK (◀◀▶▶)

- Press ▶▶▶ **4** or ◀◀◀ **4** (less than 0.5 seconds) until the desired track number appears under TRACK.
- The music stops and a moment later the selected track begins to play.

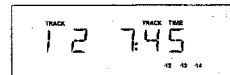

If you press ◀◀◀ **4**, you will return to a track which has already been played. If you press ▶▶▶ **4**, you will select any one of the following tracks. If you press REPEAT **12**, twice the tracks will be repeated in a different order each time, although the first track played will always be the same.

## SEARCHING FOR A PASSAGE (◀◀▶▶)

- Hold ◀◀◀ **4** down to search backwards to the beginning.
- Hold ▶▶▶ **4** down to search forwards to the end.

The searching speed is determined by how long a key is pressed:

- the first 2 seconds fairly slowly, with sound;
  - then at the maximum speed, with no sound.
- If you reach the end of the last track and release ▶▶▶ **4**, play will resume a few seconds before the end of the CD.

## STARTING WITH A PARTICULAR TRACK (◀◀▶▶)

- Press ▶▶▶ **4** or ◀◀◀ **4** (less than 0.5 seconds) until the desired track number appears under TRACK.
- Press PLAY/REPLAY **6**.
- Play starts from the selected track.

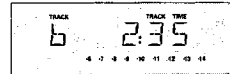

## PLAYING THE CD IN RANDOM ORDER (SHUFFLE)

- Press SHUFFLE **14** before or during play.
- If the CD compartment was open, it will now close.
- SHUFFLE lights up and all the tracks are now played in a random order.
- Press SHUFFLE again if you wish to return to normal play.



## REPEATING PLAY (REPEAT)

### Repeating a track:

- Press REPEAT **12** before or during play.
- REPEAT 1 lights up; the track will now be repeated continuously.
- Press REPEAT **twice** to stop the track being repeated.

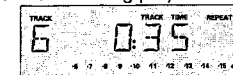

### Repeating the CD:

- Press REPEAT **12 twice** before or during play.
- REPEAT lights up; the CD will now be repeated continuously.
- Press REPEAT again to stop the CD being repeated.



## CALLING UP OTHER TIME INFORMATION (TIME)

- Press TIME **8** whenever you want to know the remaining playing time of the track being played (REM TRACK TIME).
- Press TIME again if you wish to know the remaining playing time of the entire CD (TOTAL REM TIME).
- Press TIME again if you wish to return to the elapsed playing time indication of the current track (TRACK TIME).

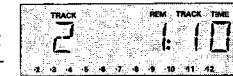

## PLAYBACK

### SEARCHING THE LOUDEST PASSAGE (PEAK SEARCH)

- In **STOP** mode, press **PEAK SEARCH 9**.
- PEAK starts flashing and the CD or the programme will now be scanned for the loudest passage (the peak).
- The display shows the track being scanned and its elapsed playing time.
- When the loudest passage has been found it will be repeated continuously (from 2 seconds before the peak until 2 seconds after the peak).
- You can now adjust your recording device.
- You can stop the search by pressing **STOP/CP 5** or **OPEN/CLOSE 7**; if you press **PLAY/REPLAY 6**, the CD or the programme will be played from the beginning.



### SETTING THE FADE-IN AND FADE-OUT TIME (FADER)

- During play press **FADER 9**.
- The sound level will now gradually decrease (FADE OUT), after which the player will go into the PAUSE mode.



- Press **FADER** again.
- Play continues and the sound level will increase again to the originally set level (FADE IN).



**NOTE!**  
The following functions can only be operated using the remote control (**CD720 only**).

### SCANNING A CD (SCAN)

- Press **SCAN 16** before or during play.
- If the CD compartment was open, it will now close.
- **SCAN** lights up for 2 seconds and the first 10 seconds of each track are played in turn; 10 seconds are counted down each time under **REM TRACK TIME**.
- When the player reaches a track which you wish to hear in full, press **SCAN** again or **PLAY/REPLAY 6**.

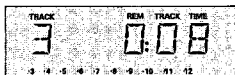

### ADJUSTING THE SOUND LEVEL (- VOLUME +)

- NOTE!**
- Use the **- VOLUME +** keys only if the player is connected to an amplifier or HiFi system *without* its own remote control.
  - The setting chosen with **- VOLUME +** will be cancelled when the player is switched off.

- Hold **- VOLUME 17** pressed down.
- **VOL** lights up; the output signal from the player will now decrease gradually.
- The successive steps are shown on the display.

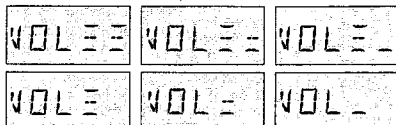

- Release the key as soon as the required sound level is obtained.
- Hold **VOLUME + 17** pressed down.
- **VOL** lights up; the output signal will now increase again gradually to the maximum level.
- The successive steps are shown on the display.

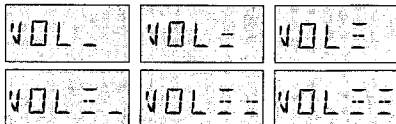

- Release the key as soon as the required sound level is obtained.

## PROGRAMMING

### STORING A PROGRAMME (PROGRAM and <<<>>>)

You can store 30 tracks from each CD in any required sequence in a programme. **FULL** lights up if you exceed the maximum of 30 tracks.

- In **STOP** mode, press **PROGRAM 10** to open the memory.
- **PROGR** lights up and **PROGRAM** starts flashing.
- Press **>>>** or **<<<** 4 (less than 0.5 seconds) until the first desired track number appears under **TRACK**.



- Press **PROGRAM 10** again.
- The track number has now been stored in the player's memory.
- Select the other track numbers required and store each track by pressing **PROGRAM**.
- The number of tracks and the playing time of your programme will be shown under **TRACK** and **TOTAL TIME**.



- The track number indicator always shows which numbers have been stored.

### PLAYING THE PROGRAMME (PLAY/REPLAY)

- Press **PLAY/REPLAY 6**.
- Playback starts with the first number of the programme.

All keys (except **PROGRAM 10** and **PEAK SEARCH 9**) can be used during programmed play. Search for a particular passage is only possible within the track being played.

### ERASING A PROGRAMME (STOP/CP or OPEN/CLOSE)

**During play:**

- Press **OPEN/CLOSE 7** or **STOP/CP 5** (twice).

**In STOP mode:**

- Press **OPEN/CLOSE 7** or **STOP/CP 5** (once).

- The programme has now been erased.



## ADDITIONAL INFORMATION

### MAINTENANCE

#### The CDs

- Never write on the printed side of a CD.
- Do not attach any stickers to the CD.
- Keep the shiny surface of the disc clean. Use a soft lint-free cloth and always wipe the disc in a straight line from centre to edge.
- Never use cleaning agents for conventional records.
- Detergents or abrasive cleaning agents should not be used either.

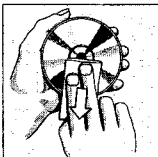

#### The player

- A chamois leather slightly moistened with water is sufficient for cleaning the player.
- Do not use cleaning agents containing alcohol, spirits, ammonia or abrasives.

### RECYCLING

Please observe the local regulations regarding the disposal of packing materials, exhausted batteries and old equipment.

1. All redundant packaging material has been omitted. We have done our utmost to make the packaging easy separable into three mono-materials:
  - cardboard (box)
  - expandable polystyrene (buffer)
  - polyethylene (bags, protective foam sheet)
2. Your set consists of materials which can be recycled if disassembled by a specialized company.
3. Do not dispose of exhausted batteries with your household waste.

### TECHNICAL DATA

#### Typical Audio Performance

Frequency range: ..... 2 Hz - 20 kHz  
 Amplitude linearity: ..... 0.3 dB (20 Hz - 20 kHz)  
 Phase linearity: ..... 4° (20 Hz - 20 kHz)  
 Dynamic range: ..... 90 dB (1kHz)  
 Signal-to-noise ratio: ..... 90 dB (1 kHz)  
 Channel separation: ..... 90 dB (1kHz)  
 Total harmonic distortion: ..... 0.003% (1kHz)  
 Audio output level: ..... 2 Vrms  
 Impedance PHONES socket **(CD720 only)**: ..... 30 - 600 ohms

#### Power supply

Mains voltage and frequency: see the type plate on the rear of the player  
 Power consumption: ..... < 10 W approx.  
 Safety requirements: ..... IEC 65

#### Cabinet

Material/finish: ..... metal and polystyrene  
 Dimensions (w x h x d): ..... 435 x 90 x 300 mm  
 Weight: ..... 4 kg approx.

**Subject to modification**

**This Compact Disc player complies with radio interference requirements as laid down in EC regulations.**

## TROUBLESHOOTING

If a fault occurs, run through the points listed below before taking your player for repair. If the fault remains, try to clear it by switching the player off and on again. If this also fails to help, consult your dealer.

**Under no circumstances should you repair the player yourself as this will invalidate the guarantee!**

SYMPTOM	POSSIBLE CAUSE	REMEDY
– Playback of the CD does not start or interruption of playback.	– The CD has been loaded upside down. – No CD inserted. – The CD is badly scratched or dirty. – Moisture condensation on the lens.	• Reload the CD, label side up. • Insert a CD, label side up. • Clean the CD with a soft, lint-free cloth. • Leave the CD player in a warm environment until the moisture evaporates.
– Sound skips (at the same part).	– The CD is dirty.	• Clean the CD with a soft, lint-free cloth.
– The CD skips tracks.	– The CD is damaged or dirty.	• Replace or clean the CD.
– Playback does not start from the first track.	– PROGRAM or SHUFFLE activated.	• Switch off SHUFFLE or clear programme.
– No sound or bad sound.	– Loose or wrong connections. – Strong magnetic fields near the CD player.	• Check connections. • Find another place for the unit or change connections.
– No sound or bad sound on headphones <b>(CD720 only)</b> .	– Level control set to – position. – Headphones plug is dirty.	• Set level control • Clean plug.
– Remote control does not function <b>(CD720 only)</b> .	– Batteries are empty.	• Replace the batteries.
– Remote control commands are not properly received <b>(CD720 only)</b> .	– The distance between remote control and CD player is larger than 10 metres.	• Use remote control receiver EM:2200/2201. • Reduce the distance between remote control and CD player.

**(GB) WARNING**

All ICs and many other semi-conductors are susceptible to electrostatic discharges (ESD). Careless handling during repair can reduce life drastically.

When repairing, make sure that you are connected with the same potential as the mass of the set via a wrist wrap with resistance. Keep components and tools also at this potential.

**ESD****(NL) WAARSCHUWING**

Alle IC's en vele andere halfgeleiders zijn gevoelig voor electrostatische ontladingen (ESD).

Onzorgvuldig behandelen tijdens reparatie kan de levensduur drastisch doen verminderen. Zorg ervoor dat u tijdens reparatie via een polsband met weerstand verbonden bent met hetzelfde potentiaal als de massa van het apparaat.

Houd componenten en hulpmiddelen ook op ditzelfde potentiaal.

**(F) ATTENTION**

Tous les IC et beaucoup d'autres semi-conducteurs sont sensibles aux décharges statiques (ESD).

Leur longévité pourrait être considérablement écourtée par le fait qu'aucune précaution n'est prise à leur manipulation.

Lors de réparations, s'assurer de bien être relié au même potentiel que la masse de l'appareil et enfiler le bracelet serti d'une résistance de sécurité.

Veiller à ce que les composants ainsi que les outils que l'on utilise soient également à ce potentiel.

**(D) WARNUNG**

Alle ICs und viele andere Halbleiter sind empfindlich gegen elektrostatische Entladungen (ESD).

Unvorsichtige Behandlung bei der Reparatur kann die Lebensdauer drastisch vermindern. Sorgen Sie dafür, dass Sie im Reparaturfall über ein Pulsarmband mit Widerstand mit dem Massepotential des Gerätes verbunden sind. Halten Sie Bauteile und Hilfsmittel ebenfalls auf diesem Potential.

**(I) AVVERTIMENTO**

Tutti IC e parecchi semi-conduttori sono sensibili alle scariche statiche (ESD).

La loro longevità potrebbe essere fortemente ridotta in caso di non osservazione della più grande cauzione alla loro manipolazione. Durante le riparazioni occorre quindi essere collegato allo stesso potenziale che quello della massa dell'apparecchio tramite un braccialetto a resistenza.

Assicurarsi che i componenti e anche gli utensili con quali si lavora siano anche a questo potenziale.

**(GB)**

Safety regulations require that the set be restored to its original condition and that parts which are identical with those specified be used.

**(NL)**

Veiligheidsbepalingen vereisen, dat het apparaat in zijn oorspronkelijke toestand wordt teruggebracht en dat onderdelen, identiek aan de gespecificeerde worden toegepast.

**(D)**

Bei jeder Reparatur sind die geltenden Sicherheitsvorschriften zu beachten. Der Originalzustand des Geräts darf nicht verändert werden für Reparaturen sind Original-Ersatzteile zu verwenden.

**(I)**

Le norme di sicurezza esigono che l'apparecchio venga rimesso nelle condizioni originali e che siano utilizzati pezzi di ricambio identici a quelli specificati.

**(F)**

Les normes de sécurité exigent que l'appareil soit remis à l'état d'origine et que soient utilisées les pièces de rechange identiques à celles spécifiées.



**CLASS 3B  
LASER PRODUCT**

**CAUTION  
VARO!  
VARNING  
ADVERSEL  
DANGER  
VORSICHT**

INVISIBLE LASER RADIATION WHEN OPEN AVOID EXPOSURE TO BEAM

AVATTAESSA OLET ALTTIINA NÄKYMÄTTÖMÄLLE LASER SÄTTEILYLLE ÄLÄ KATSO SÄTEESEN

OSYNLIG LASERSTRÅLNING NÄR DENNA DEL ÄR ÖPPNAD BETRakta EJ STRÅLEN

USYNLIG LASERSTRÅLING VED ÅBNING. UNDGÅ UNSAETTEELSE FOR STRÅLING

INVISIBLE LASER RADIATION WHEN OPEN AVOID DIRECT EXPOSURE TO BEAM

UNSICHTBARE LASERSTRAHLUNG WENN ABDECKUNG GEÖFFNET NICHT DEM STRAHL AUSSETZEN

"Pour votre sécurité, ces documents doivent être utilisés par des spécialistes agréés, seuls habilités à réparer votre appareil en panne"

**CLASS 1  
LASER PRODUCT**

3427 110 03420

**SERVICING HINTS**

In the set chip components have been applied. For disassembly and assembly of chip components see the figure below.

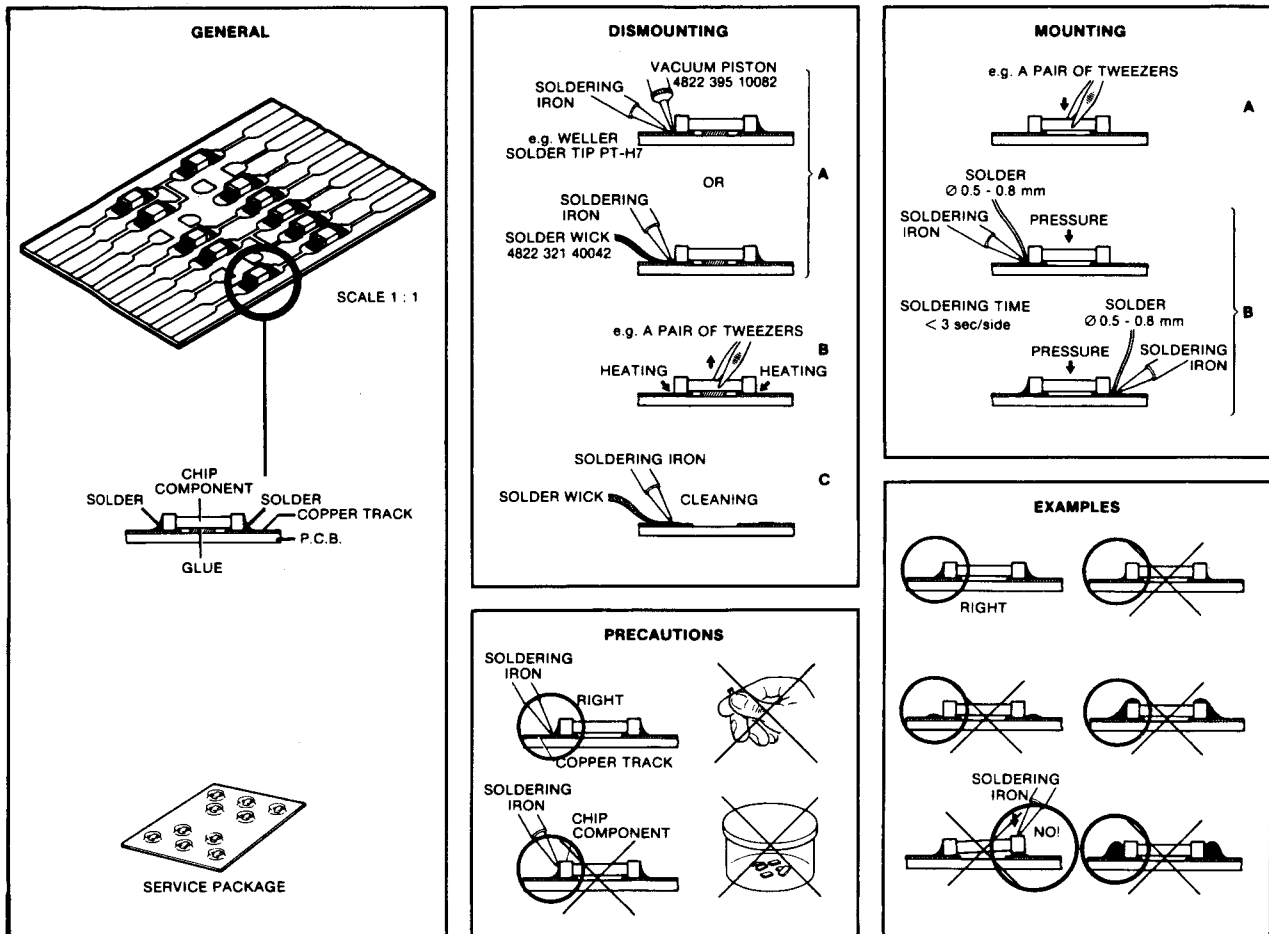

27 012C12

**SERVICE TOOLS**

- |  |                |
|--|----------------|
| Audio signal disc  | 4822 397 30184 |
| Disc without errors (test disc 5) + disc with DO errors, black spots and fingerprints (test disc 5A) | 4822 397 30096 |
| Disc (65 min 1kHz) without pause   | 4822 397 30155 |
| Max. diameter disc (58.0 mm)   | 4822 397 60141 |
| Torx screwdrivers  |                |
| Set (straight)   | 4822 395 50145 |
| Set (square)   | 4822 395 50132 |
| 13th order filter  | 4822 395 30204 |

**DISMANTLING INSTRUCTIONS**

OPEN EXPLODED VIEW ON PAGE 33

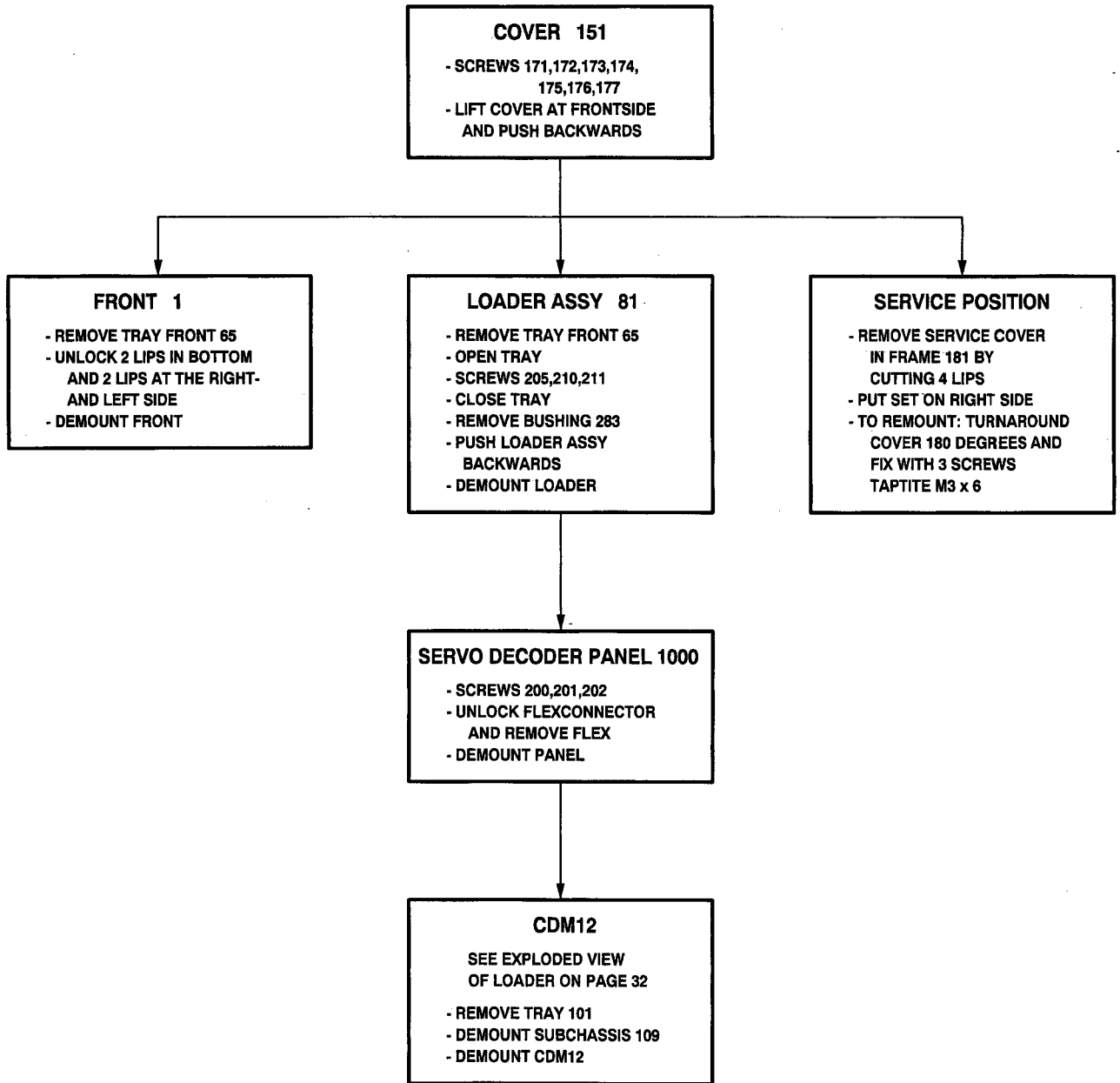

**SERVICE TEST PROGRAM**

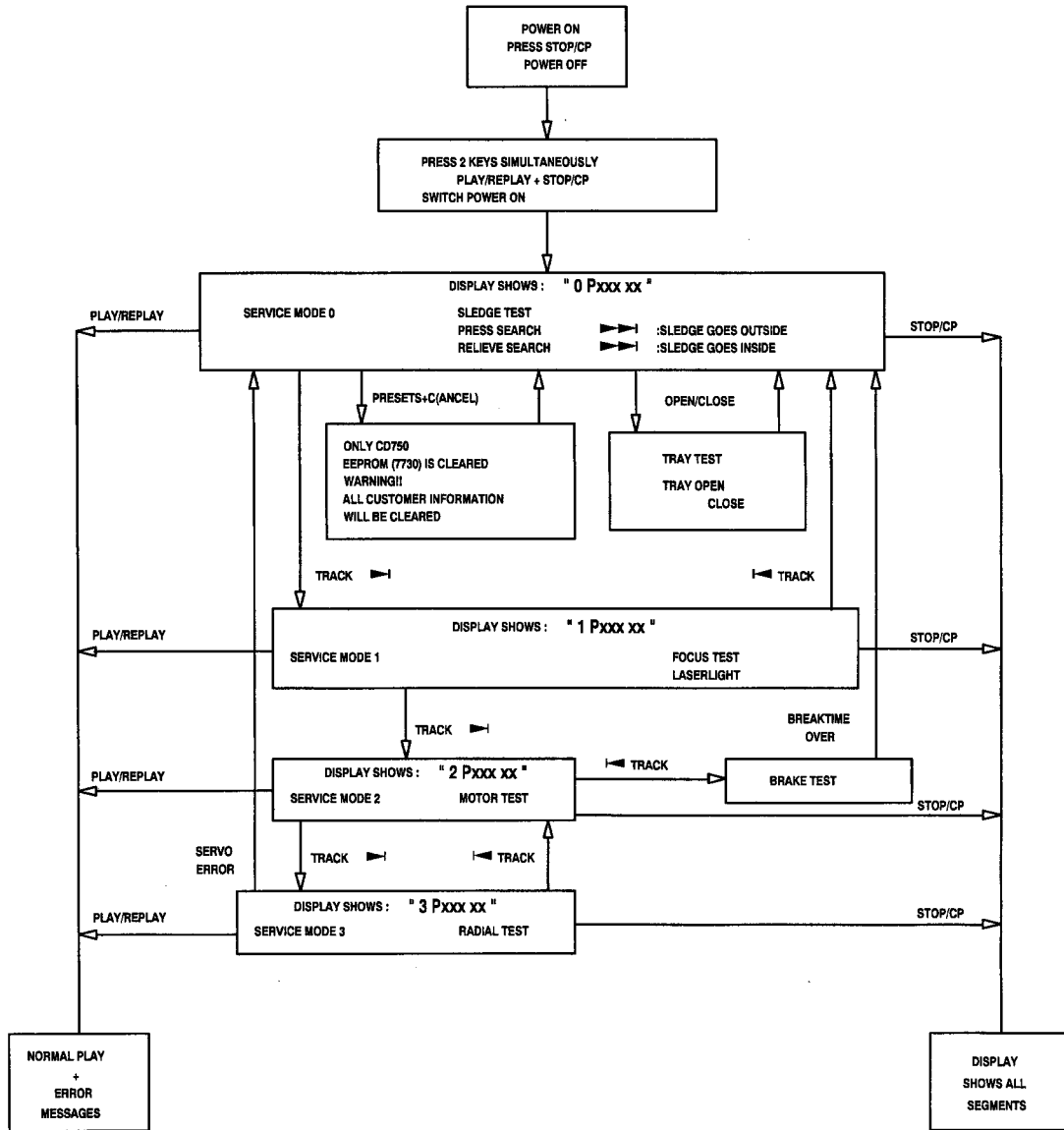

**ERROR MESSAGES**

- "SLEDGE ERROR"
- "FOCUS ERROR"
- "RADIAL ERROR"
- "MOTOR ERROR"
- "EEP ER"
- "EEP OK"

Pxxx = PROGRAM OF MICROPROCESSOR  
xx = VERSION OF PROGRAM

HAS1120  
9342

CDM 12.1 start up diagram.

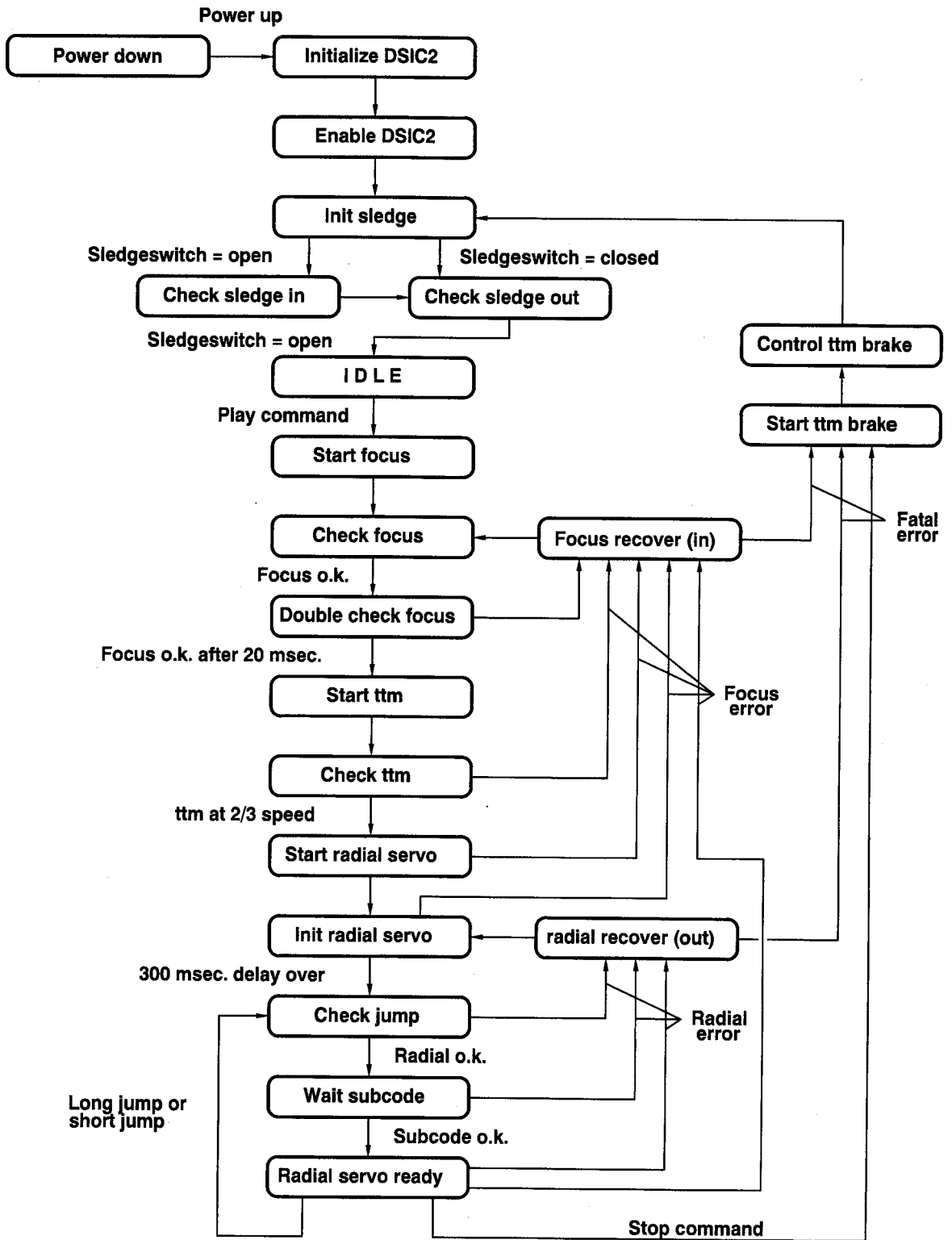

**FAULT FINDING GUIDE CDM 12.1**

Main Fault Finding Guide CDM 12.1  
System

Listen to kind of "scratching sound" while slowly turning the disc by hand.

Disc is turning clock wise at normal speed.

Activity on RAD+  
(pin 4 connector 1052)

\*After "play" starts at track 1 at time 0:00.  
\*Go to outer track and start again at time 0:00 after max. 6 seconds.

\*Try search function.

\*When going from "Pauze" to "play" music has to restart at the same place.

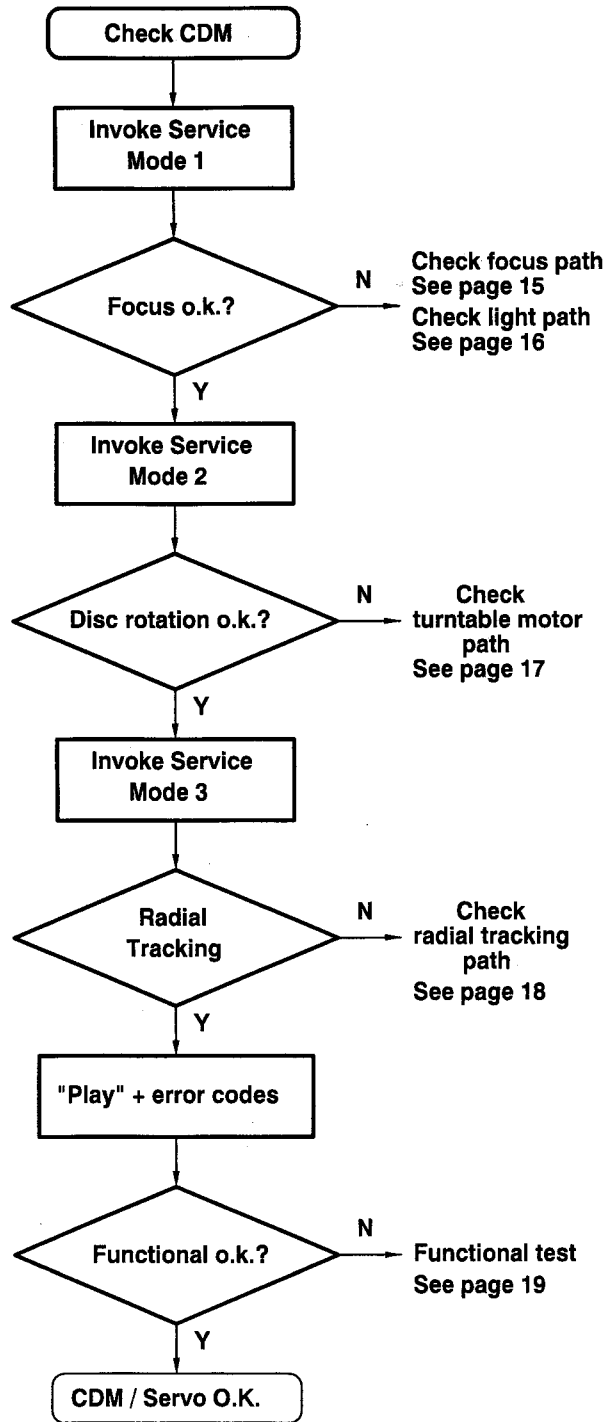

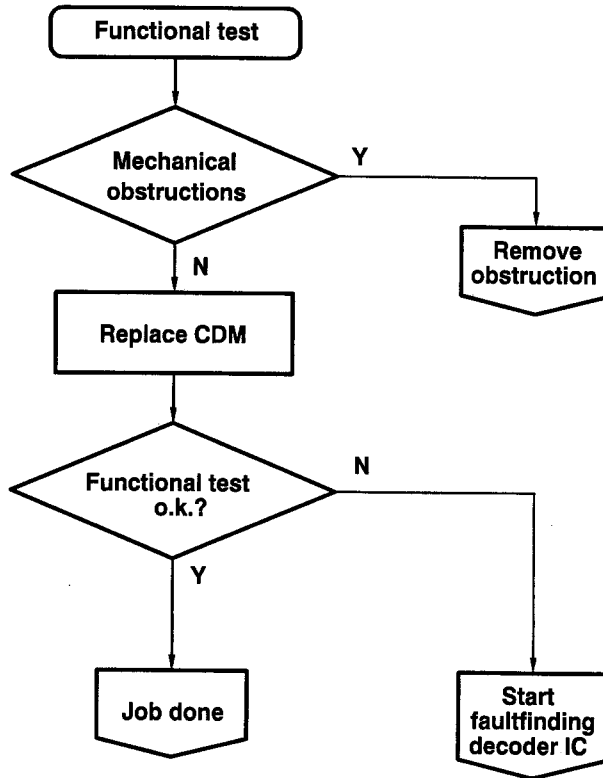



FAULTFINDING GUIDE

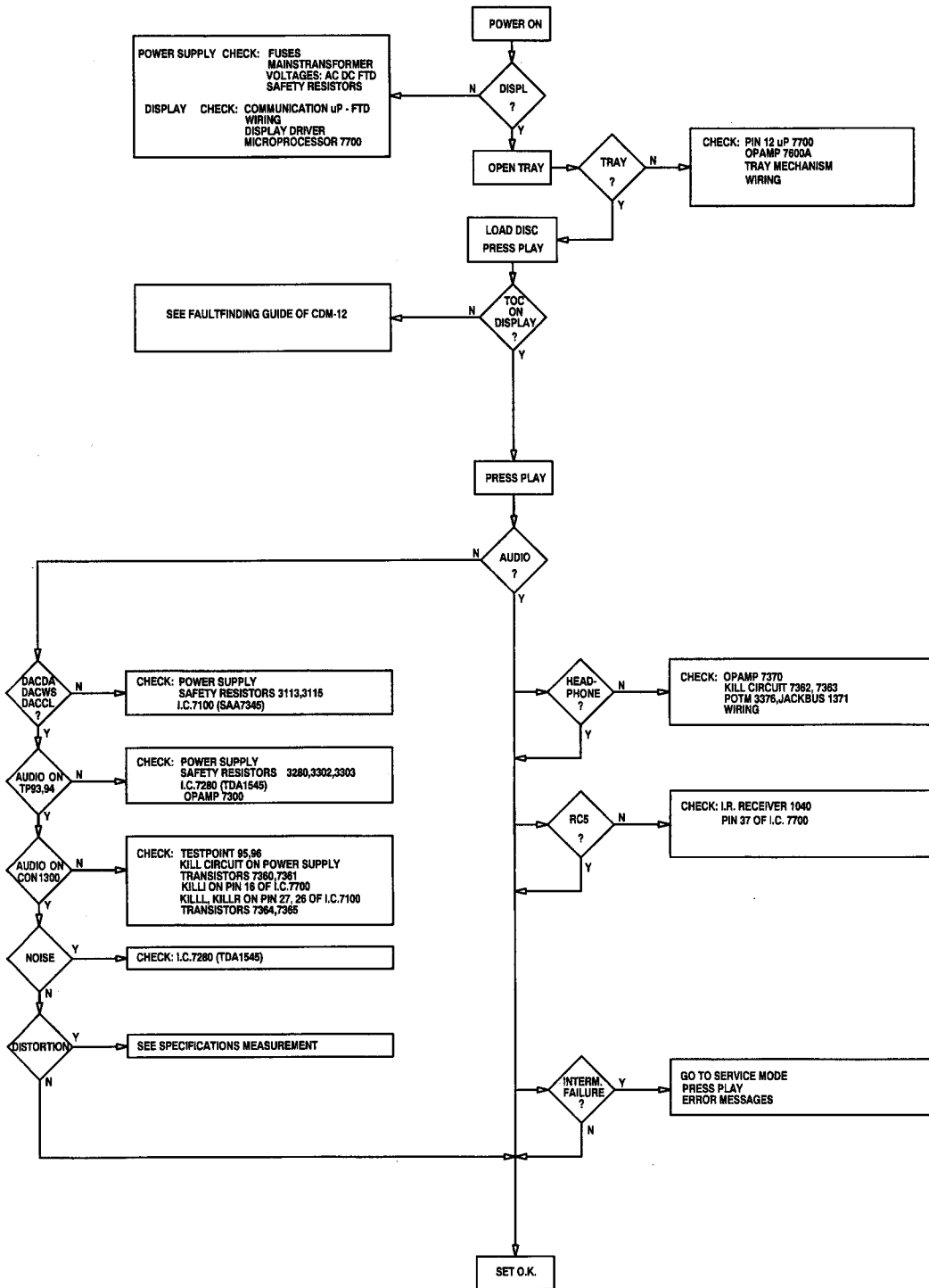

HAS1123  
9345

## SPECIFICATIONS MEASUREMENT

SIGNAL	AUDIO SIGNALS DISC 1	TESTPOINT	REMARKS
ANALOG OUT LEFT	TOTAL HARMONIC DISTORTION TRACKS 10 - 23	FILTER OUTPUT	SEE TECHNICAL DATA SEE DRAWING
ANALOG OUT RIGHT			
ANALOG OUT LEFT	SIGNAL-TO-NOISE RATIO TRACK 1 REFERENCE LEVEL TRACK 49	FILTER OUTPUT	SEE TECHNICAL DATA SEE DRAWING
ANALOG OUT RIGHT			

FILTER = 13TH ORDER FILTER 4822 395 30204

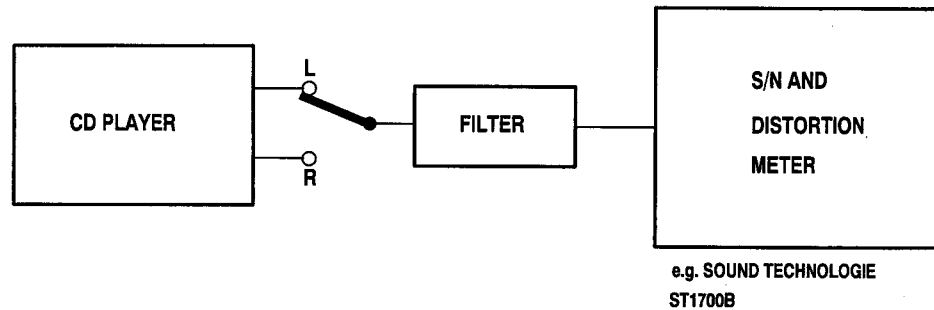

## ABBREVIATIONS

BCK	Bit clock input of CC-DAC TDA1545
CFLG	correction flag output
CL	interface clock input line
CL11	11.2896 MHz clock output
CL16	16.9344 MHz system clock output
CLA	4.2336 MHz microprocessor clock output
CLO	Clock output
CRIN	crystal/resonator input
CROUT	crystal/resonator output
D1-D4	Central diode input of TDA1301
D1-D5	Photodiode signals from CDM12 mechanism
DA	interface data I/O line
DACCL	Bit clock output of CD6 decoder SAA7345
DACDA	Data output of CD6 decoder SAA7345
DACWS	Word select output of CD6 decoder SAA7345
DATA	serial data output/Data input of CC-DAC TDA1545
DOBM	biphase mark output
FO	Focus actuator output
FOC+	+Connection of focus actuator
FOC-	Ground connection of focus actuator
HF	High-Frequency signal to decoder input
HFIN	comparator signal input
HFREF	comparator common-mode input
IOL	Left channel current output
IOR	Right channel current output
IREF	Reference current output
ISLICE	current feedback from data slicer
LDON	Laser drive on
MISC	general purpose DAC output
MOTO1	motor output 1
MOTO2	motor output 2
NRST	Reset input
OTD	Off track detector
PORE	power-on reset enable input(active low)
R1-R2	Satellite diode signal input
RA	Radial actuator output
RAB	interface R/W and acknowledge input
RAD+	+Connection of radial actuator
RAD-	Ground connection of radial actuator
SCLK	serial bit clock output
SICL	Serial interface clock
SIDA	Serial interface data
SILD	Serial interface load
SL OUT	+Connection of sledge motor
SL	Sledge output
TEST1	test input
TEST2	test input
TS1-TS2	Test inputs
V1-5	Versatile input pins
WCLK	Word clock output
WS	Word select input of CC-DAC TDA1545
XTLI	Oscillator input
XTLO	Oscillator output
XTLR	Oscillator reference

DIODES			MAINS VOLTAGE		
6360	4822 130 30621	1N4148	5500 ▲	4822 146 31337	MAINS TRANSFO /00B
6361	4822 130 30621	1N4148	5500 ▲	4822 146 31339	MAINS TRANSFO /05B
6400	4822 130 30613	BAW62	5500 ▲	4822 146 31338	MAINS TRANSFO /01B
6401	4822 130 30613	BAW62			
6402	4822 130 30613	BAW62			
6500	4822 130 31981	BZX79-C3V9			
6535	5322 130 30684	1N4002GP			
6536	5322 130 30684	1N4002GP			
6537	5322 130 30684	1N4002GP			
6538	5322 130 30684	1N4002GP			
6540	5322 130 30684	1N4002GP			
6541	4822 130 34278	BZX79-C6V8			
6542	4822 130 30621	1N4148			
6543	5322 130 30684	1N4002GP			
6544	4822 130 30621	1N4148			
6560	5322 130 30684	1N4002GP			
6561	5322 130 30684	1N4002GP			
6562	4822 130 31981	BZX79-C3V9			
TRANSISTORS & IC'S					
7000	4822 209 31064	TDA1301T/N1			
7040	4822 130 40902	BF240			
7041	4822 130 40937	BC548B			
7042	4822 130 44197	BC558B			
7043	4822 130 40937	BC548B			
7044	4822 130 40937	BC548B			
7060	4822 209 72587	TCA0372			
7061	4822 209 72587	TCA0372			
7100	4822 209 33166	SAA7345GP/M2A			
7280	4822 209 33164	TDA1545AT/N2			
7300	4822 209 83274	NJM4560D			
7360	4822 130 44121	BC338			
7361	4822 130 44121	BC338			
7362	4822 130 44121	BC338			
7363	4822 130 44121	BC338			
7364	4822 130 44197	BC558B			
7365	4822 130 44197	BC558B			
7370	4822 209 82362	NJM4556D			
7400	4822 209 30249	TMP47C212AN			
7500	4822 130 44197	BC558B			
7535 ▲	4822 209 80891	MC7805CT			
7540	5322 209 62115	MC79L15AC			
7541	4822 130 40937	BC548B			
7542	4822 130 44121	BC338			
7543	4822 130 44197	BC558B			
7600	4822 209 72587	TCA0372			
7650	4822 130 44197	BC558B			
7700	4822 209 33249	MC68HC11ER20/P159-07			





... (A) ...

**Wichtig für die Werkstatt!**

Nummer: 52139

S I

Sachgebiet: AC 52 CD

Datum: 30.09.1994

## Service Information

Betrifft: CD-Spieler CD710/CD720  
Service-Hinweise

Verteiler: INTERN und EXTERN

### 1. Fokusfehler

Durch das Zusammenwirken von Eigenschaften des Laufwerkes CDM12.1 und des Servo-IC TDA1301 kann es bei einem ganz besonderen Plattenfehler ("white dropout" mit einer Dauer von ca. 100µs) zum Aussetzen der Fokussierung kommen, obwohl CD's mit diesem Fehler noch dem Standard entsprechen. Zur Verbesserung der Fokusfunktion in solchen Fällen wird den beiden Photodioden D2 und D3 ein kleiner Offset-Strom zugeführt. Dazu sind am Servo-IC TDA1301 je ein Widerstand 3M9 von Pin 4 (VRH) nach Pin 5 und nach Pin 6 zugefügt worden.

Widerstand 3M9 4822 050 23905

### 2. Resetfunktion

Zur Verbesserung der Resetfunktion bei höheren Umgebungstemperaturen ist ab Woche 9425 der Resetpegel von 4V auf 4.5V erhöht worden durch Ändern des Widerstandes 3500 (Service Manual S.27; Decoderschaltbild).

3500 (560E) geändert in 150E 4822 116 52211

### 3. Decoder-IC

In Geräten aus Fertigung ab Woche 9420 ist das Decoder-IC 7100 (SAA7345GP/M2A) ersetzt worden durch SAA7345GP/M5. Die beiden Ausführungen sind **n i c h t k o m p a t i b e l !**

Mit der Einführung der .../M5-Version ist die Oszillator-Beschaltung des Decoder-IC geändert worden:

- R3117 (330E) ersetzt durch Drahtbrücke
- C2112 hinzugefügt von Pin 13/7100 nach Masse
- C2112 22pF 4822 122 33191
- Resonator 1101 ersetzt durch eine andere Ausführung mit abweichender interner Kapazität
- 1101 16.93MHz 4822 242 81865

Bei Ersatz des Decoder-IC 7100 ist auf die verwendete Ausführung zu achten; beide Versionen sind verfügbar:

7100	SAA7345GP/M2A	4822 209 33166
7100	SAA7345GP/M5	4822 209 33339

4812 829 52139

Philips GmbH · Geschäftsbereich Service · Hamburg

Service  
Service  
Service

Soll eine IC-Version durch die andere ersetzt werden, dann muß die Oszillator-Beschaltung angepaßt werden (s. Abb.).

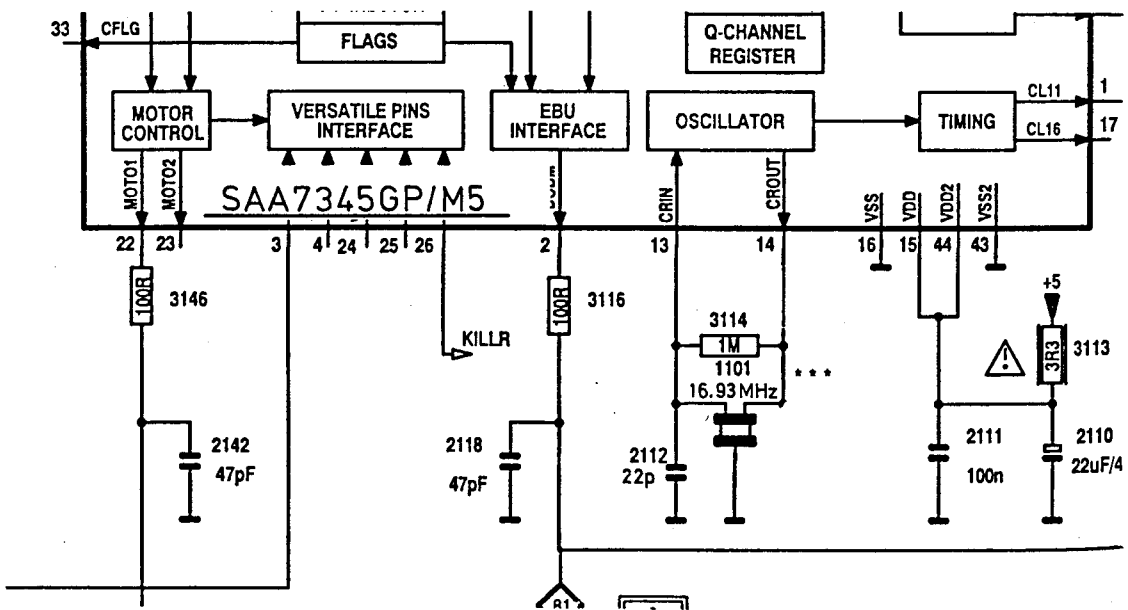
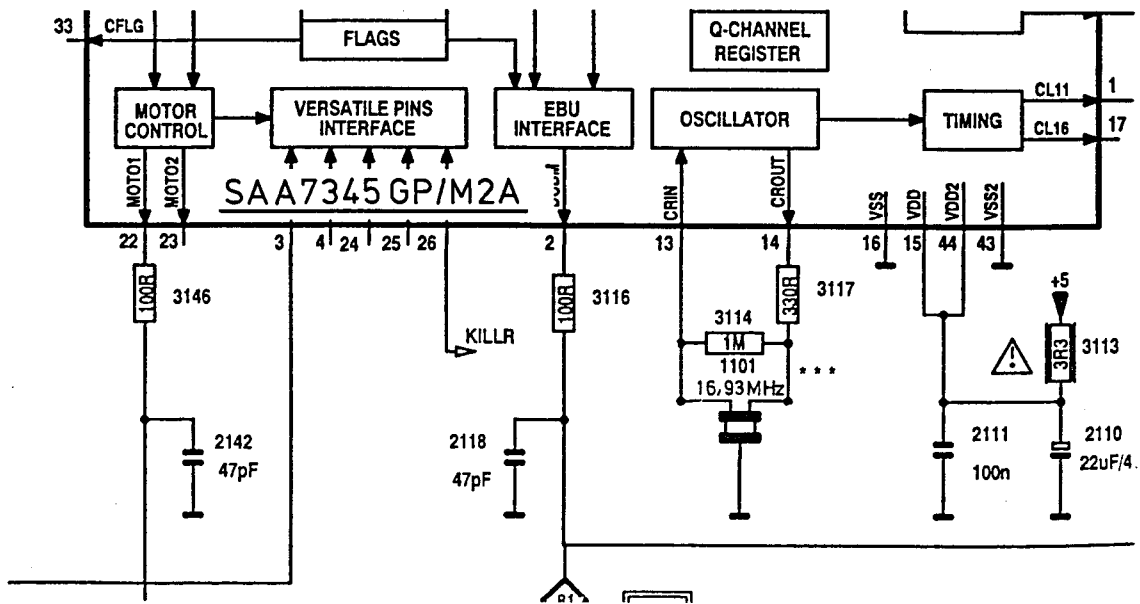

4. Netzteil

Von Beginn der Fertigung an ist als Diode 6540 (Service Manual, S.25) nicht der Typ 1N4002 sondern 1N4004 verwendet worden.

6540 1N4004

4822 130 83362

5. HF-Verstärker

Von Beginn der Fertigung an ist der Wert des Kondensators 2050 (Service Manual, S.26) nicht 330pF sondern 220pF.

2050 220pF

4822 122 10466





### 3.4. Functional description

#### 3.4.1. Front-end

##### Data slicer

The SAA7345 has an integrated slice level comparator which is clocked by the crystal frequency clock.

The slice level is controlled by an internal current source applied to an external capacitor under the control of the digital phase-locked loop(DPLL).

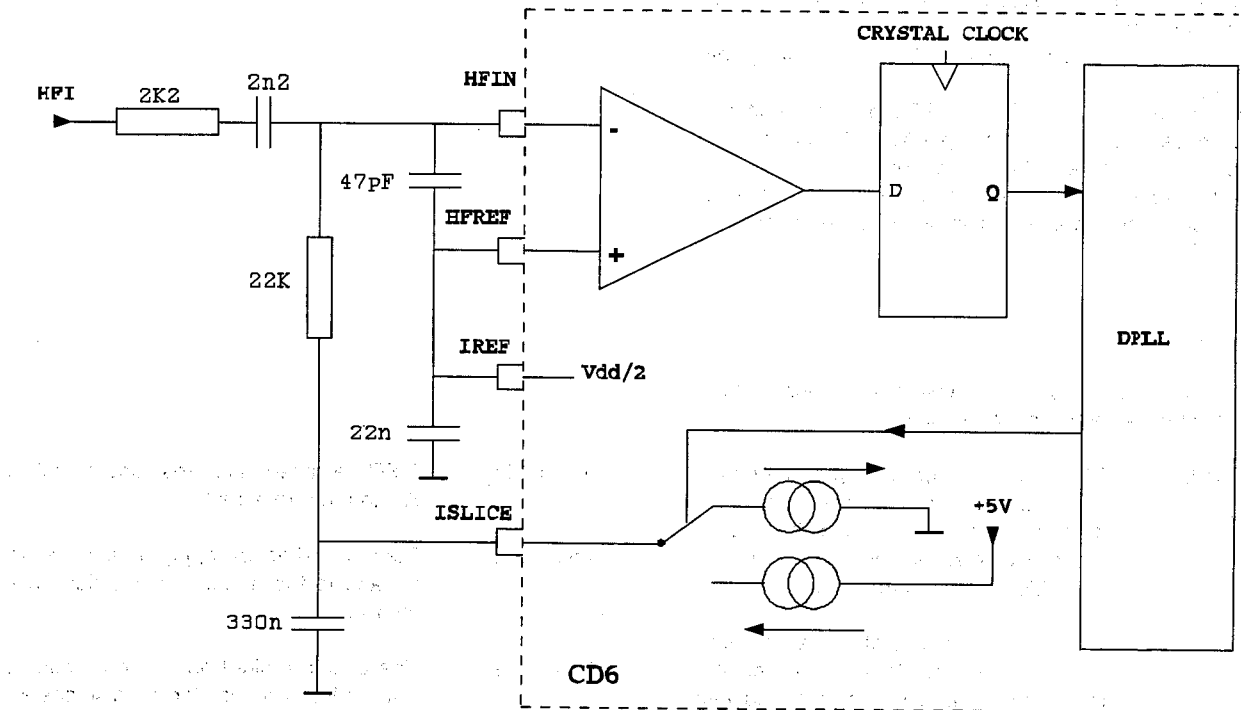

##### Digital PLL

Regeneration of the bit clock is achieved with an internal fully digital PLL. No external components are required and the bit clock is not output. The PLL has two micro-processor control registers(addresses 1000 and 1001) for bandwidth and equalization.

An offtrack input(OTD) is input via the V1 pin (pin3) of the versatile pins interface. When this flag is HIGH, the SAA7345 will assume that the servo is following on the wrong track, and will flag all incoming HF data as incorrect.

##### Error corrector

The error corrector carries out  $t=2, e=0$  error corrections on both C1(32 symbol) and C2(28 symbol) frames. Four symbols are used from each frame as parity symbols. The strategy  $t=2, e=0$  means that the error corrector can correct two erroneous symbols per frame and detect all erroneous frames.

The error corrector also contains a flag processor. Flags are assigned to symbols when the error corrector cannot ascertain if the symbols are definitely good. C1 generates output flags which are read (after de-interleaving) by C2, to help in the generation of C2 output flags.

The C2 output flags are used by the interpolator for concealment of uncorrectable errors. They are also output via the EBU signal(DOBM) and the MISC output with I<sup>2</sup>S for CD-ROM applications.

The flags output pin CFLG provides information on the state of all error correction and concealment flags. In comparison with CD4+, CD6 has a better error corrector. The error correction performance of CD6 depends on which crystal is used and on which speed is performed. The best performance is achieved with a 33.9 MHz crystal at single speed.

### 3.4.2. Turntable motor control

The turntable motor speed is controlled by a fully integrated digital servo. Address information from the internal + 8 frame FIFO and disc speed information are used to calculate the motor control output signals.

Several output modes are supported:

1. Pulse Density Modulation, 2-line(true complement output), 1MHz sample frequency.
2. PWM output, 2-line, 22.05 kHz modulation frequency.
3. PWM output, 4-line, 22.05 kHz modulation frequency.
4. CDV motor mode.

The modes are selected via the motor output configuration register.

In this application, the single-ended PDM mode is used.

In this mode, the motor output pin MOTO1 contains an accelerating as well as a braking action.

50% duty cycle corresponds with the motor not actuated, higher duty cycles mean acceleration, lower mean braking.

#### Operation modes

The motor servo has the following operation modes controlled by the motor mode register.

Start mode 1	Disc is accelerated by applying a positive voltage to the spindle motor. No decisions are involved and the PLL is reset. No disc speed information is available for the microprocessor.	Play mode	FIFO released after resetting to 50%. Audio mute released.
Start mode 2	The disc is accelerated as in Start mode 1, however the PLL will monitor the disc speed. When the disc reaches 75% of its nominal speed, the controller will switch to Jump mode.	Stop mode 1	Disc is braked by applying a negative voltage to the motor. No decisions are involved.
Jump mode	Motor servo enabled but FIFO kept rest at 50%. The audio is muted but it is possible to read the subcode.	Stop mode 2	The disc is braked as in Stop mode 1, but the PLL will monitor the disc speed. As soon as the disc reaches 12% of its nominal speed, the MOTSTOP status signal will go HIGH and switch servo to Off mode.
Jump mode 1	Similar to Jump mode but motor integrator is kept at zero. Used for long jumps.	Off mode	Motor is not steered.

### 3.4.3. Audio functions

#### De-emphasis and phase linearity

When de-emphasis is detected in the Q-channel subcode, the digital filter automatically includes a de-emphasis filter section.

When de-emphasis is not required, a phase compensation filter section controls the phase linearity of the digital oversampling filter to  $\leq \pm 1^\circ$  within the band 0 to 16 kHz.

#### Digital oversampling filter

The SAA7345 contains a 2-4 times oversampling IIR filter. This means that the impulse response of this filter is infinite.

The advantage of using an IIR filter is that it is easy and cheap to implement on a chip. The main disadvantage is that it is inherently not phase linear.

#### Concealment

A 1-sample linear interpolator becomes active if a single sample is flagged as erroneous but cannot be corrected. The erroneous sample is replaced by a level midway between the preceding and following samples. Left and right channels have independent interpolators.

If more than one consecutive uncorrectable sample is found, the last good sample is held. A 1-sample linear interpolation is then performed before the next good sample.

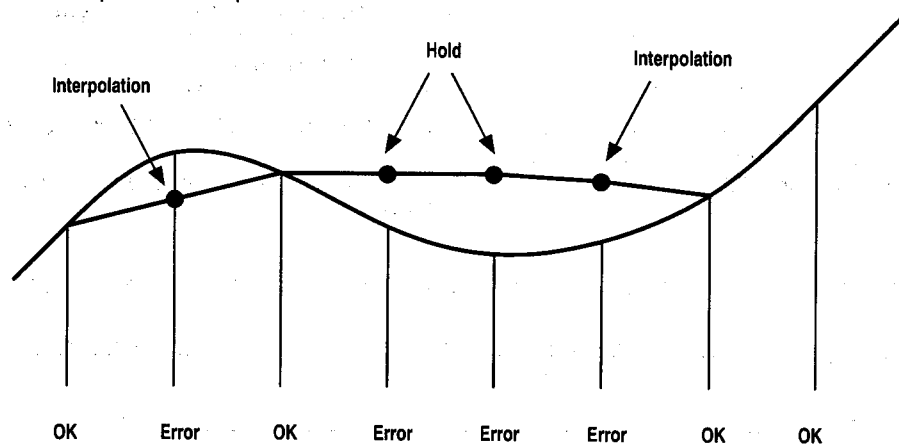

Concealment mechanism

#### Mute, Attenuation and Fade

A digital level controller is present on the SAA7345 which performs the functions of soft mute, attenuation and fade. All these functions are software programmable.

Soft mute is activated by sending the Mute command to the fade control register, attenuation (-12dB) is activated by sending the Attenuate command. Attenuation and mute are cancelled by sending the full scale command.

The audio output is determined by the value of the internal fade counter.

$$\text{Level} = \frac{\text{counter}}{128} \times \text{maximum level}$$

The counter is preset to 128 by the Full scale command if no oversampling is required.

The counter is preset to 120 (-0.5dB scaling) by the Full scale command if either 2 or 4 fs oversampling is programmed in the DAC output register.

The counter is preset to 32 by the Attenuate command.

The counter is preset to 0 by the Mute command.

To control the fade counter in a continuous way, the step-up and step-down commands are available. They will increment or decrement the counter by 1 for each register write operation.

**Serial data interface**

SAA7345 can be used in the CD-ROM mode, in fs (= no oversampling), in 2 fs or in 4fs (= 4 times oversampled) mode by programming the corresponding register.

Also the DAC output format can be programmed (Japanese 16 or 18 bit or Philips 16 bit). There are 10 possible DAC output formats :

MODE	SAMPLE FREQ.	BITS	SCLK Mhz	Fig.	DAC type	INTERPOLATIONS
1	Fs	16	2.1	A	CD-ROM	NO
2	Fs	16	2.1	A	Philips 16 bits	Yes
3	Fs	16	2.1	B	Japanese 16 bits	Yes
4	Fs	18	2.1	B	Japanese 18 bits	Yes
5	4Fs	16	8.5	B	Japanese 16 bits	Yes
6	4Fs	18	8.5	B	Japanese 18 bits	Yes
7	4Fs	16	8.5	A	Philips 16 bits	Yes
8	2Fs	16	4.2	B	Japanese 16 bits	Yes
9	2Fs	18	4.2	B	Japanese 18 bits	Yes
10	2Fs	16	4.2	A	Philips 16 bits	Yes

Mode 3 is used in CD750 with NPC filter SM5840A and BSDAC SAA7350. For description of NPC filter and BS DAC we refer to Circuit Description CD93 part II order no. 4822 725 24042

Mode 5 is used in CD710/720 with CC-DAC TDA1545.

Mode 6 is used in CD740 and CD911/921 with BCC-DAC TDA1549.

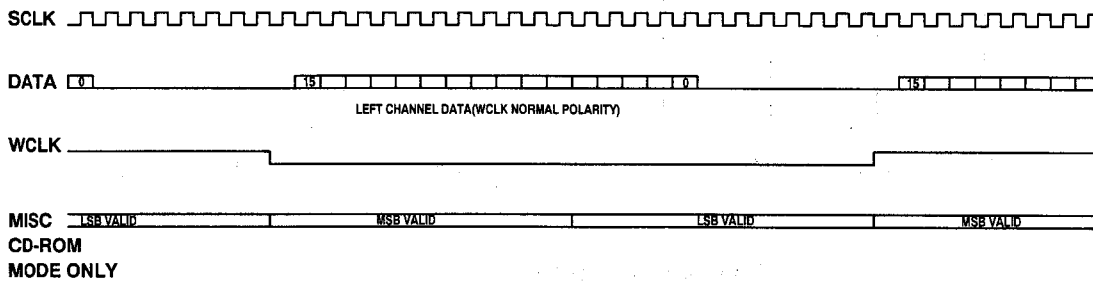

**Fig. A Philips I2S data format(16-bit word length shown)**

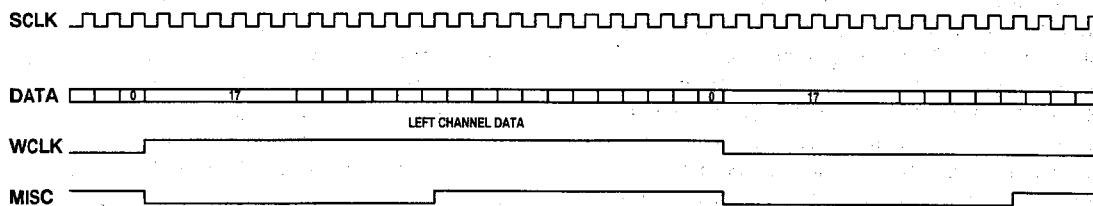

**Fig. B Japanese data format(18-bit word length shown)**

**Peak detector output**

In place of the CRC-bits(Cyclic Redundancy Check) 81 to 96, the peak detector information is added to the Q-channel data. The peak information corresponds to the highest audio level and is measured on positive peaks.

**Digital output interface**

The biphasemark digital output signal at pin DOBM is according to the format defined by the IEC958 specification. The digital audio output consists of 32-bit words transmitted in biphasemark code( two transitions for logic 1 and one transition for a logic 0). Left and right audio samples are transmitted alternately.

**Kill circuit**

The kill circuit detects digital silence by testing for an all-zero or all-ones data word in the left or right channel before the digital filter. The KILL pin 27 is active-LOW when digital silence has been detected in the LEFT channel for 200 ms, and V3 pin 26 is active-LOW when digital silence has been detected in the RIGHT channel for 200 ms.

When MUTE is active then the KILL outputs are forced LOW.

## 4. Stereo continuous calibration DAC TDA1545

### 4.1. General description

The TDA1545 is the first device of a new generation of digital-to-analog converters which embodies the innovative technique of continuous calibration. The largest bit-currents are repeatedly generated by one single current reference source.

This duplication is based upon an internal charge storage principle having an accuracy insensitive to ageing, temperature and process variations.

### 4.2. Block diagram

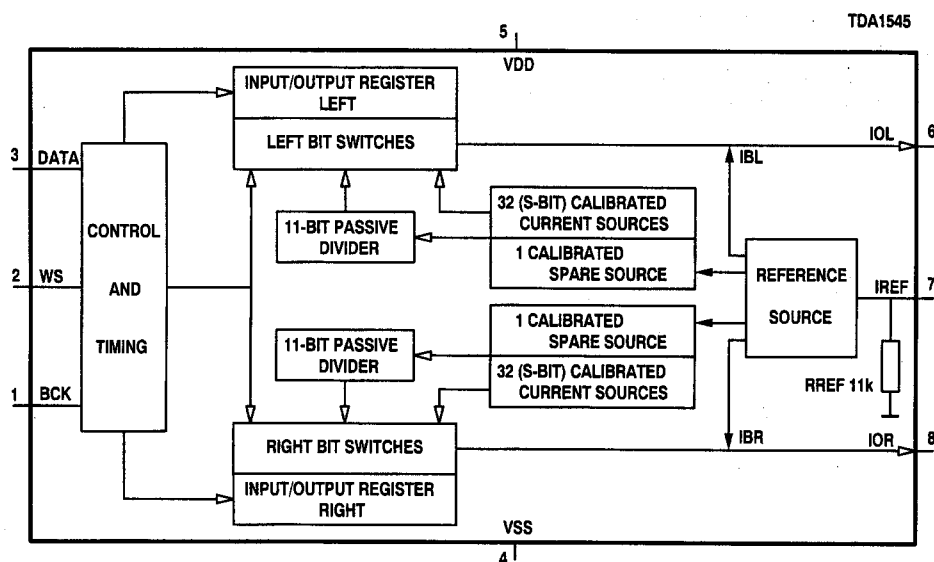

HAS1154

### 4.3. Pin description

PIN	SYMBOL	DESCRIPTION
1	BCK	bit clock input
2	WS	word select input
3	DATA	data input
4	GND	ground
5	VDD	positive supply voltage
6	IOL	left channel output
7	IREF	reference current input
8	IOR	right channel output

### 5.4. Functional description

#### General

The TDA1549 CMOS D/A bitstream continuous calibration converter incorporates internal digital filtering which increases the oversampling rate of 4fs input data to 96fs, and removes the spectral data components around 4fs, 8fs and 12fs.

A second-order noise shaper operating at 96fs outputs a five-bit data bitstream to the D/A converters. The filtering required for waveform smoothing and out-of-band noise reduction is achieved by simple first-order analog post-filtering.

#### Input

The circuit accepts four times oversampled data in 18-bit 2's complement standard Japanese format with MSB first. Left and right data-channel words are time multiplexed.

The bit clock(BCK) operates at 192fs i.e. 48 times the word select(WS) frequency of 4fs.

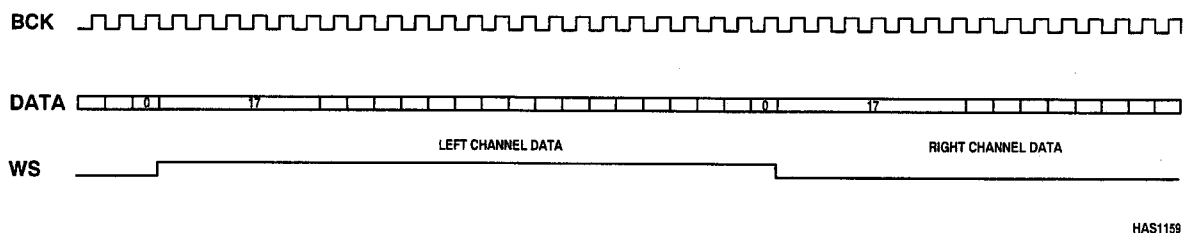

fig 5.1 : Input format

#### Oversampling filter

The oversampling filter consists of:

- A seventh order halfband low pass FIR filter which increases the oversampling rate from 4 times to 8 times. This removes the spectral components around 4fs and 12fs.
- A linear interpolation section which increases the oversampling rate to 16 times. This removes the spectral components around 8fs.
- A sample and hold section which provides another 6 times oversampling to 96 times. The zero-order hold characteristic of this sample and hold section plus the first order analog filtering remove the spectral components around 16fs.

The passband ripple is within 0.1dB. The stopband attenuation is >50dB around multiples of the sampling frequency.

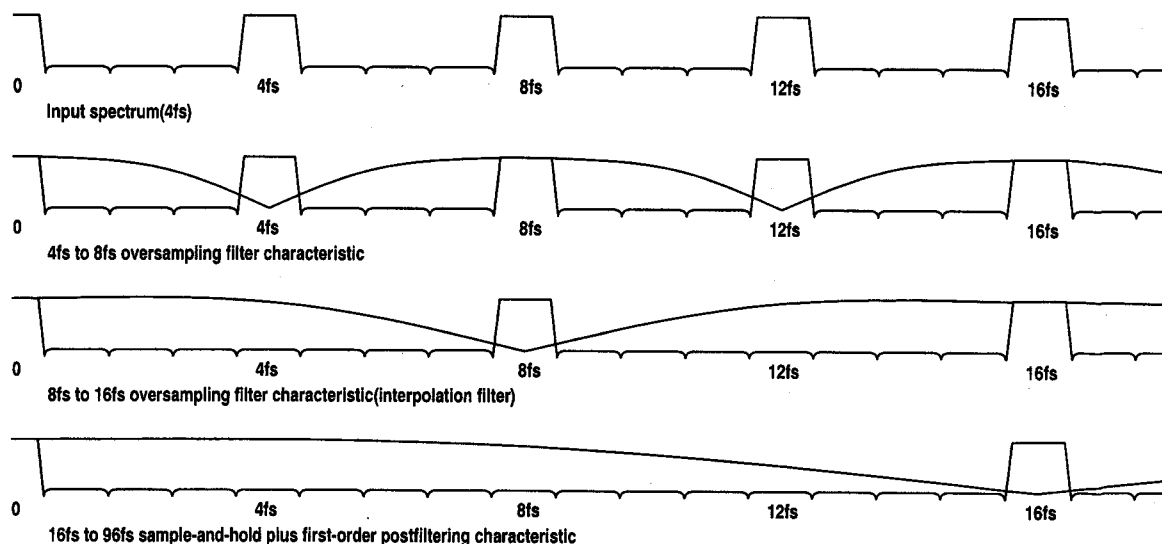

HAS1160

Fig 5.2 : Filter and noise shaper characteristics



### **Noise shaper**

The 2nd-order digital noise shaper converts the 18bit data at 96fs into a 5-bit bitstream, while shifting in-band quantisation noise to frequencies well above the audio band. For low signal levels the noise shaper output is a one-bitstream. This noise shaping technique used in combination with a special data code and bitstream converter enables extremely high signal-to-noise ratios to be achieved.

### **Data encoder**

The data encoder converts the five-bit 2's complement output data from the noise shaper to a 32-bit thermometer code.

In traditional unidirectional current converters, half the full-scale current flows to the output during small signal reproduction. The thermal noise and substrate crosstalk components, present in this current, severely restrict the dynamic range which can be attained. In this BCC-DAC true low-noise performance is achieved using a special data code and bidirectional current sources. The special data code guarantees that only small values of current flow to the output during small-signal passages while larger positive or negative signals are generated using the bidirectional sources. Furthermore, for every change in the 18 bit input sample only one current source or current sink is switched on. This intrinsically monotonic thermometer code ensures the high differential linearity, zero crossover distortion and superior signal-to-noise ratio associated with bitstream conversion.

### **Continuous Calibration D/A converter.**

The DAC currents(16 sources and 16 sinks) of each channel are repeatedly generated from one single reference current. See description of CC-DAC TDA1545.

### **Operational amplifiers**

High precision, low-noise amplifiers together with the internal conversion resistors RCONV1 and RCONV2 convert the converter output current to a voltage capable of driving a line output. This voltage is available at VOL and VOR(1.5Vrms typical). Connecting external capacitors CEXT1 and CEXT2 between resp. IOL and VOL, IOR and VOR provides the required first order postfiltering for the left and right channels. The RC combinations determine the first-order fall-off frequencies.

### **Internal reference circuitry**

Internal reference circuitry ensures that the output voltage signal is proportional to the supply voltage, thereby maintaining maximum dynamic range for supply voltages from 3.4 to 5.5V.

Service  
Service  
Service



# Service Manual

## Introduction of CD722/00

For Service documentation please refer to Service Manual

CD720 - 4822 725 24056

V02137# 1024132

CD722/00 refers to CD720/00B except the following:

### A. Mechanical parts list - Loader

Pos No.	Service code	Description
110	4822 464 10325	Chassis

### B. Mechanical Parts list - Set

Pos No.	Service code	Description
1	4822 459 04711	Front Assembly
8	4822 410 63803	Button Set
14	4822 459 11055	Wordmark
15	4822 450 62475	Window Display
65	4822 442 01068	CD Tray Front
151	4822 444 61045	Top Cover
251-254	4822 462 10968	Foot
255-258	-	Deleted
283	-	Deleted
308	4822 321 22832	Cable Assembly
340	4822 736 15592	Instruction For Use
365	4822 219 10343	Remote Control



# Service



# Service Manual

## TABLE OF CONTENTS

## PAGE

1. Technical specifications	2
2. Instructions for use	3
3. Warnings	9
4. Servicing hints	10
5. Dismantling instructions	11
6. Service test program	12
7. CDM12 start up diagram	13
8. Faultfinding diagram CDM12	14
9. Faultfinding diagram decoder part	20
10. Specifications measurement	21
11. Abbreviations	22
12. Block diagram	23
13. Wiring diagram	24
14. Circuit diagrams and printed boards	
14.1. Power supply	25
14.2. Servo circuit diagram	26
14.3. Decoder circuit diagram	27
14.4. DAC circuit diagram	28
14.5. Main panel component side	29
14.6. Main panel solder side	30
14.7. Control & Display & Headphone	31
15. Loader	32
16. Mechanical Partslist	33
17. Exploded view	33
18. Electrical partslist	34



## TECHNICAL SPECIFICATIONS

### General

1. Mains voltage	/00B	: 230V (+6 -10%)
	/05B	: 240V ( $\pm 10\%$ )
	/01B	: 110V-127V/220V-240V
2. Mains frequency		: 50-60 Hz
3. Mains voltage selection only	/01B	: Voltage selector 2 positions
4. Power consumption mains	standby	: < 3W
	operated	: < 10W

### Remote Control(only CD720)

Internal: RC5

### Line output

1. Number of channels		: 2
2. Output voltage		: 2 Vrms $\pm 3$ dB
3. Output resistance		: 1 k $\Omega$
4. Dynamic range (-60 dB)		: min. 84 dB from 20 Hz to 20 kHz
5. Unbalance left-right		: max. 1 dB
6. Channel separation		: min. 82 dB from 20 Hz to 20 kHz
7. Signal to noise ratio		: min. 83 dB from 20 Hz to 20 kHz
8. Total harmonic distortion + noise		: min. 70 dB from 20 Hz to 20 kHz
9. Frequency response		: max. $\pm 0.5$ dB from 20 Hz to 20 kHz
10. Phase non-linearity		: max 7.0° from 20 Hz to 16 kHz
11. Automatic switched deemphasis with time constant 15/50 $\mu$ s		
12. Out-band attenuation		: min. 35 dB (above 40 kHz)

### Variable headphone(only CD720) (low end)

1. Output voltage		: max. 5 Vrms $\pm 3$ dB
2. Unbalance left-right		: max. $\pm 1.2$ dB
3. Output resistance		: 120 $\Omega$
4. Load impedance range		: 30 $\Omega$ to 600 $\Omega$
5. Output power		: 0 to 30 mW into 30 $\Omega$ load
		: 0 to 50 mW into 150 $\Omega$ load
		: 0 to 30 mW into 600 $\Omega$ load

Audio specs in case of 600  $\Omega$  load at 4 Vrms voltage output

6. Signal to noise ratio		: min. 80 dB
7. Dynamic range		: min. 70 dB (20 Hz -20 kHz)
8. Total harmonic distortion		: min. 60 dB (20 Hz - 20 kHz)
9. Channel separation		: min. 70 dB (1 kHz)
		: min. 65 dB (31.5 Hz - 16 kHz)

### Dimensions and weight

1. Apparatus tray closed		: WxDxH 435 x 260 x 74/90 mm
2. Apparatus tray open		: WxDxH 435 x 405 x 74/90 mm
3. Weight		: 3 kg

### Optical read-out system

1. Laser type		: Semiconductor AlGaAs
2. Wavelength		: 780 nm $\pm 20$ nm
3. Light output (c.w.)		: max. 0.5 mW

V02137  
V02093  
V02082  
V02080

## Compact disc

Service  
Service  
Service

New key components of CD94 program  
CD6 Decoder SAA7345  
CC\_DAC TDA1545  
BCC-DAC TDA1549

# Circuit Description

## CONTENTS

<b>1. Block diagrams</b>	
1.1. Block diagram CD710/CD720 .....	1-1
1.2. Block diagram CD740/CD911/CD921 .....	1-2
1.3. Block diagram CD750 .....	1-3
<b>2. Circuit diagrams</b>	
2.1. Decoder circuit diagram .....	2-1
2.2. DAC circuit diagram CD710/CD720 .....	2-2
2.3. DAC circuit diagram CD740/CD911/CD921 .....	2-3
2.4. DAC circuit diagram CD750 .....	2-4
<b>3. CD6 decoder SAA7345</b>	
3.1. General description .....	3-1
3.2. Block diagram .....	3-1
3.3. Pin description .....	3-2
3.4. Functional description .....	3-3
<b>4. Stereo continuous calibration DAC TDA1545</b>	
4.1. General description .....	4-1
4.2. Block diagram .....	4-1
4.3. Pin description .....	4-1
4.4. Functional description .....	4-2
<b>5. BCC-DAC TDA1549</b>	
5.1. General description .....	5-1
5.2. Block diagram .....	5-1
5.3. Pin description .....	5-2
5.4. Functional description .....	5-3



# CONTENTS

	PAGE
<b>INSTALLATION</b> .....	<b>5</b>
Fitting a mains plug (U.K. only) .....	5
Power supply setting .....	5
Connections .....	5
Connecting headphones (CD720 only) .....	5
<b>FUNCTIONAL OVERVIEW</b> .....	<b>6-7</b>
Front of player .....	6
Remote control (CD720 only) .....	6
Display .....	7
Display messages .....	7
<b>PLAYBACK</b> .....	<b>8-10</b>
Normal playback .....	8
Selecting another track .....	9
Searching for a passage .....	9
Starting with a particular track .....	9
Playing the CD in random order .....	9
Repeating play .....	9
Calling up other time information .....	9
Searching the loudest passage .....	10
Setting the fade-in and fade-out time .....	10
Scanning a CD (CD720 only) .....	10
Adjusting the sound level (CD720 only) .....	10
<b>PROGRAMMING</b> .....	<b>11</b>
Storing a programme .....	11
Playing a programme .....	11
Erasing a programme .....	11
<b>ADDITIONAL INFORMATION</b> .....	<b>12</b>
Maintenance .....	12
Recycling .....	12
Technical data .....	12
<b>Troubleshooting</b> .....	<b>13</b>

# INSTRUCTIONS FOR USE

## INSTALLATION

### POWER SUPPLY SETTING

- Check that the type plate at the bottom of your player indicates the correct supply voltage.
- If your mains supply voltage is different, consult your dealer or our Service Organisation.
- *Certain versions of this player are equipped with a voltage selector at the bottom of the player which enables you to set the player to the correct mains voltage yourself.*

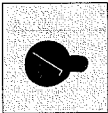

*Position 120 V: for all mains voltages between 110V and 127 V.  
Position 230 V: for all mains voltages between 220V and 240 V.*

### CONNECTIONS

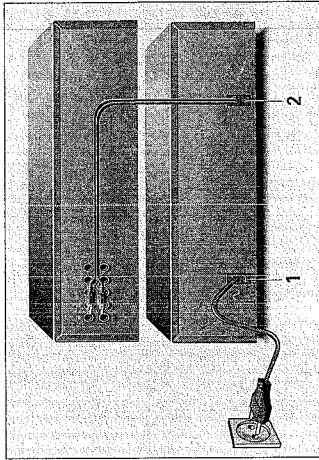

- 1 Mains connection**  
• Connect the mains lead to your mains supply.
- 2 Connecting cable to the amplifier**  
• Insert the red plug (right channel) and the white plug (left channel) into the corresponding sockets of the CD or AUX input of your amplifier. You can also use the TUNER or TAPE IN-connection, but **never** the PHONO input!

### CONNECTING HEADPHONES (CD720 only)

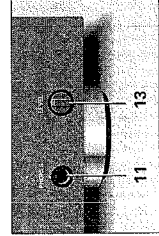

- Connect headphones with a 6.3 mm jack plug to the PHONES socket **11**.
- The sound level is adjusted with the LEVEL control **13**.

### FITTING A MAINS PLUG (U.K. only)

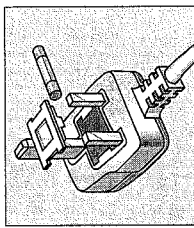

This apparatus is fitted with an approved moulded 13 Amp plug. To change a fuse in this type of plug proceed as follows:

- Remove fuse cover and fuse.
- Fix new fuse which should be a BS1362 5A, A.S.T.A. or BSI approved type.
- Refit the fuse cover.

If the fitted plug is not suitable for your socket outlets, it should be cut off and an appropriate plug fitted in its place.

If the mains plug contains a fuse, this should have a value of **5A**. If a plug without a fuse is used, the fuse at the distribution board should not be greater than **5A**.

#### NOTE

*The severed plug must be disposed to avoid a possible shock hazard should it be inserted into a 13A socket elsewhere.*

### HOW TO CONNECT A PLUG

The wires in the mains lead are coloured in accordance with the following code:

BLUE – "NEUTRAL", ("N") and BROWN – "LIVE" ("L"). As these colours may not correspond with the colour markings identifying the terminals in your plug, proceed as follows:

- The BLUE wire must be connected to the terminal which is marked with the letter "N" or coloured BLACK.
- The BROWN wire must be connected to the terminal which is marked with the letter "L" or coloured RED.
- Do **not** connect either wires to the earth terminal in the plug which is marked by the letter "E" or by the safety earth symbol or coloured green or green-and-yellow.

Before replacing the plug cover, make certain that the cordgrip is clamped over the sheath of the lead – not simply over the two wires.

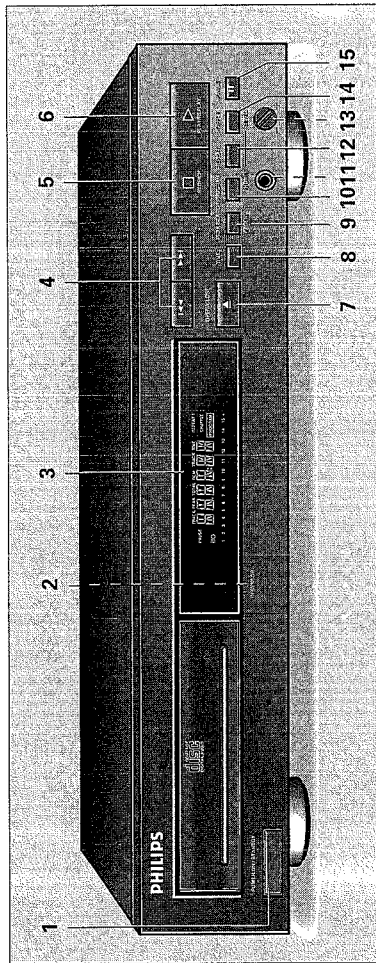

## FRONT OF PLAYER

- 1 **POWER ON/STANDBY** – Switching on and off.
- 2 **(Infra) Red Sensor (CD720 only)**  
Receives the signals from the remote control.
- 3 **Display** – Informs you about the functioning of the player.
- 4 **◀◀ and ▶▶**  
Selecting another track.  
Selecting a track to start play with.  
Fast search to a particular passage during play.
- 5 **STOP/CP**  
Stopping play.  
Erasing a programme (CP = Clear Programme).
- 6 **PLAY/REPLAY**  
Starting play.  
Returning to the beginning of a track.
- 7 **OPEN/CLOSE** – Opening and closing the CD compartment. The compartment also closes when the front is pressed briefly.
- 8 **TIME** – Selecting the time information you want to see.
- 9 **PEAK SEARCH** – Searching the loudest passage (peak) on a CD or in a programme when making a tape recording.  
**FADER** – Fading in and out during play.
- 10 **PROGRAM**  
Opening the memory when compiling a programme.  
Storing tracks in a programme.
- 11 **PHONES (CD720 only)**  
Connecting headphones.
- 12 **REPEAT** – Repeating play.
- 13 **LEVEL (CD720 only)** – Adjusting the volume when listening with headphones.

- 14 **SHUFFLE** – Playback in random order.
- 15 **PAUSE** – Interrupting play.

## REMOTE CONTROL (CD720 only)

- The life of the batteries of the remote control is around one year. For replacement only use batteries of the type RO3, UM4 or AAA.
- The buttons on the remote control have the same functions as the corresponding ones on the player.
- Extra buttons:
  - 16 **SCAN** – Automatically playing the beginning of each track.
  - 17 **VOLUME +** – Adjusting the sound level when the player is connected to an amplifier or HiFi system without its own remote control.

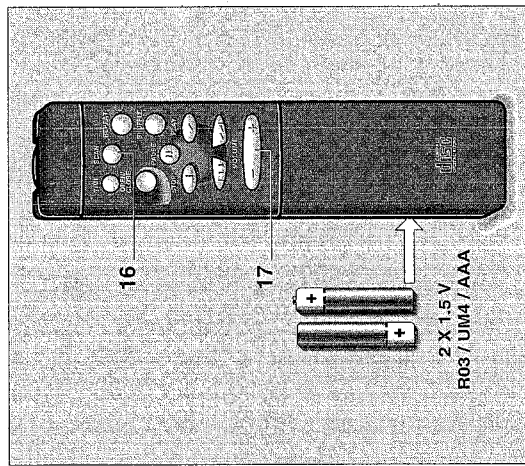

## DISPLAY



**PAUSE**  
Lights up when play is interrupted.  
Lights up when the player receives a command from the remote control.

**TRACK** – Indicates:  
– what track is being played;  
– the number of tracks on the CD or in a programme.

**PEAK**  
– Flashes when the loudest passage (peak) on a CD or in a programme is being searched.  
– Lights up when the loudest passage (peak) has been found.

**TRACK TIME**  
Indicates the elapsed playing time of the track being played.

**REM(aining) TRACK TIME**  
Indicates the remaining playing time of the track being played.

**TOTAL REM(aining) TIME**  
Indicates the remaining playing time of the CD or a programme.

**TOTAL TIME**  
Indicates the total playing time of the CD or a programme.

**REPEAT**  
Lights up when you repeat a CD or a programme.

**REPEAT 1**  
Lights up when you repeat a track.

**SHUFFLE**  
Lights up when the tracks are played in random order.

**PROGRAM**  
– Flashes when a programme is being compiled.  
– Lights up when a programme has been stored in the player memory.

**1-15 track number indicator**  
Shows the number of tracks on the CD.

+ Lights up when there are more than 15 tracks on the CD.

## DISPLAY MESSAGES



Lights up when the CD's contents list is being scanned.



Lights up when there is no CD in the CD compartment.



Scrolls on the display when insert a non audio CD (CD-ROM, CD-I or CDV).



Scrolls on the display if you select a non-existent track number.



Scrolls on the display if you try to activate a function for which you must first start play.



Scrolls on the display if you try to activate a function for which you must first stop play.

# PLAYBACK

## NORMAL PLAYBACK (PLAY/REPLAY)

**NOTE!** Use only audio CDs; no CD-ROM, CD-I or CDV.

- Press POWER ON/STANDBY **1** to switch the player on.
- Open the CD compartment by pressing OPEN/CLOSE **7**.
- OPEN lights up.
- Insert an audio CD, **printed side up**, and close the compartment by pressing OPEN/CLOSE **7**.

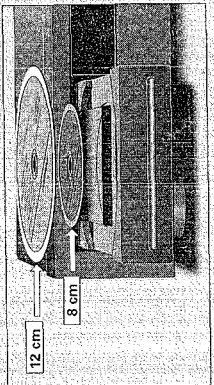
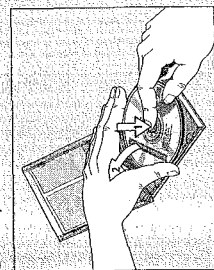

- CLOSE lights up, followed by READ. The number of tracks and the playing time of the CD are shown on the display.

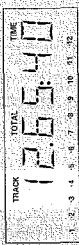

- Press PLAY/REPLAY **6** to start play. You can also press PLAY/REPLAY immediately after inserting the CD; the compartment then closes automatically. You can also close the CD compartment by pressing its front; playback will then start automatically.
- The number indicator shows how many tracks are on the CD; when a track has been played its number disappears.

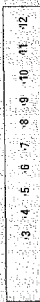

- The track being played is always shown under TRACK and its elapsed playing time is shown under TRACK TIME.



- Play will stop after the last track.
- Press POWER ON/STANDBY **1** to switch the player off.

You can interrupt playback by pressing PAUSE **15**, PAUSE then lights up. Press PLAY/REPLAY **6** to restart; if you first press PAUSE again and then PLAY/REPLAY, the current track starts again from the beginning. You can also restart play by pressing SCAN **16** (on the remote control - **CD720 only**) or SHUFFLE **14**. If you press PLAY/REPLAY during play, the current track starts again from the beginning. You can stop playback by pressing STOP/CP **5** or OPEN/CLOSE **7**.

# PLAYBACK

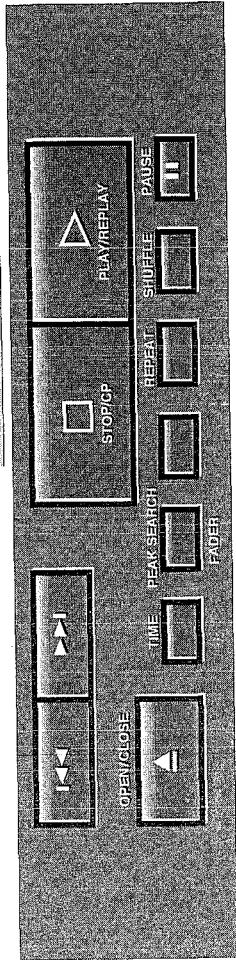

## SELECTING ANOTHER TRACK (◀◀◀ ▶▶▶)

- Press ▶▶▶ **4** or ◀◀◀ **4** (less than 0.5 seconds) until the desired track number appears under TRACK.
- The music stops and a moment later the selected track begins to play.



## SEARCHING FOR A PASSAGE (◀◀◀ ▶▶▶)

- Hold ◀◀◀ **4** down to search backwards to the beginning.
  - Hold ▶▶▶ **4** down to search forwards to the end.
- The searching speed is determined by how long a key is pressed:
- the first 2 seconds fairly slowly, with sound;
  - then at the maximum speed, with no sound.
- If you reach the end of the last track and release ▶▶▶, play will resume a few seconds before the end of the CD.

## STARTING WITH A PARTICULAR TRACK (◀◀◀ ▶▶▶)

- Press ▶▶▶ **4** or ◀◀◀ **4** (less than 0.5 seconds) until the desired track number appears under TRACK.
- Press PLAY/REPLAY **6**.
- Play starts from the selected track.



## PLAYING THE CD IN RANDOM ORDER (SHUFFLE)

- Press SHUFFLE **14** before or during play.
- If the CD compartment was open, it will now close.
- SHUFFLE lights up and all the tracks are now played in a random order.
- Press SHUFFLE again if you wish to return to normal play.



If you press ◀◀◀ **4** you will return to a track which has already been played. If you press ▶▶▶ **4**, you will select any one of the following tracks.

If you press REPEAT **12**, twice the tracks will be repeated in a different order each time, although the first track played will always be the same.

## REPEATING PLAY (REPEAT)

### Repeating a track:

- Press REPEAT **12** before or during play.
- REPEAT 1 lights up; the track will now be repeated continuously.
- Press REPEAT twice to stop the track being repeated.

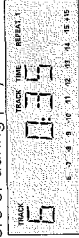

### Repeating the CD:

- Press REPEAT **12** twice before or during play.
- REPEAT lights up; the CD will now be repeated continuously.
- Press REPEAT again to stop the CD being repeated.





## CALLING UP OTHER TIME INFORMATION (TIME)

- Press TIME **8** whenever you want to know the remaining playing time of the track being played (REM TRACK TIME).
- Press TIME again if you wish to know the remaining playing time of the entire CD (TOTAL REM TIME).
- Press TIME again if you wish to return to the elapsed playing time indication of the current track (TRACK TIME).





**SEARCHING THE LOUDEST PASSAGE (PEAK SEARCH)**

- In **STOP** mode, press **PEAK SEARCH 9**.  

- PEAK starts flashing and the CD or the programme will now be scanned for the loudest passage (the peak).
- The display shows the track being scanned and its elapsed playing time.  

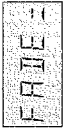
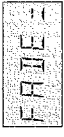
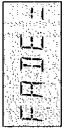
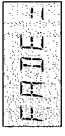
- When the loudest passage has been found it will be repeated continuously (from 2 seconds before the peak until 2 seconds after the peak).
- You can now adjust your recording device.
- You can stop the search by pressing **STOP/CP 5** or **OPEN/CLOSE 7**; if you press **PLAY/REPLAY 6**, the CD or the programme will be played from the beginning.

**SETTING THE FADE-IN AND FADE-OUT TIME (FADER)**

- During play press **FADER 9**.  

- The sound level will now gradually decrease (FADE OUT), after which the player will go into the PAUSE mode.  

- Press **FADER** again.  

- Play continues and the sound level will increase again to the originally set level (FADE IN).  

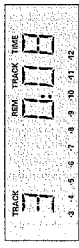
**NOTE!**  
 The following functions can only be operated using the remote control (CD720 only).

**SCANNING A CD (SCAN)**

- Press **SCAN 16** before or during play.
- If the CD compartment was open, it will now close.
- **SCAN** lights up for 2 seconds and the first 10 seconds of each track are played in turn; 10 seconds are counted down each time under **REM TRACK TIME**.
- When the player reaches a track which you wish to hear in full, press **SCAN** again or **PLAY/REPLAY 6**.



**ADJUSTING THE SOUND LEVEL (- VOLUME +)**

- **NOTE!**
- Use the **- VOLUME +** keys only if the player is connected to an amplifier or HiFi system without its own remote control.
- The setting chosen with **- VOLUME +** will be cancelled when the player is switched off.
- Hold **- VOLUME 17** pressed down.
- **VOL** lights up; the output signal from the player will now decrease gradually.
- The successive steps are shown on the display.

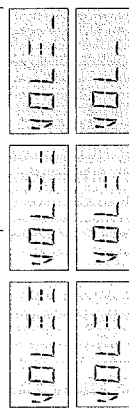

- Release the key as soon as the required sound level is obtained.
- Hold **VOLUME + 17** pressed down.
- **VOL** lights up; the output signal will now increase again gradually to the maximum level.
- The successive steps are shown on the display.

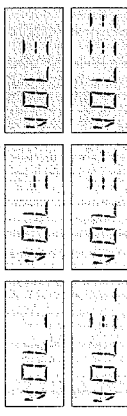

- Release the key as soon as the required sound level is obtained.

**STORING A PROGRAMME (PROGRAM and TRACK)**

You can store 30 tracks from each CD in any required sequence in a programme. **FULL** lights up if you exceed the maximum of 30 tracks.

- In **STOP** mode, press **PROGRAM 10** to open the memory.
- **PROGR** lights up and **PROGRAM** starts flashing.
- Press **▶▶▶** or **◀◀◀ 4** (less than 0.5 seconds) until the first desired track number appears under **TRACK**.



- Press **PROGRAM 10** again.
- The track number has now been stored in the player's memory.
- Select the other track numbers required and store each track by pressing **PROGRAM**.
- The number of tracks and the playing time of your programme will be shown under **TRACK** and **TOTAL TIME**.



– The track number indicator always shows which numbers have been stored.

**PLAYING THE PROGRAMME (PLAY/REPLAY)**

- Press **PLAY/REPLAY 6**.
- Playback starts with the first number of the programme.

All keys (except **PROGRAM 10** and **PEAK SEARCH 9**) can be used during programmed play. Search for a particular passage is only possible within the track being played.

**ERASING A PROGRAMME (STOP/CP or OPEN/CLOSE)**

- **During play:**
  - Press **OPEN/CLOSE 7** or **STOP/CP 5** (twice).
- **In STOP mode:**
  - Press **OPEN/CLOSE 7** or **STOP/CP 5** (once).
- The programme has now been erased.

# TROUBLESHOOTING

If a fault occurs, run through the points listed below before taking your player for repair. If the fault remains, try to clear it by switching the player off and on again. If this also fails to help, consult your dealer.  
**Under no circumstances should you repair the player yourself as this will invalidate the guarantee!**

SYMPTOM	POSSIBLE CAUSE	REMEDY
<ul style="list-style-type: none"> <li>Playback of the CD does not start or interruption of playback.</li> </ul>	<ul style="list-style-type: none"> <li>The CD has been loaded upside down.</li> <li>No CD inserted.</li> <li>The CD is badly scratched or dirty.</li> <li>Moisture condensation on the lens.</li> </ul>	<ul style="list-style-type: none"> <li>Reload the CD, label side up.</li> <li>Insert a CD, label side up.</li> <li>Clean the CD with a soft, lint-free cloth.</li> <li>Leave the CD player in a warm environment until the moisture evaporates.</li> </ul>
<ul style="list-style-type: none"> <li>Sound skips (at the same part).</li> </ul>	<ul style="list-style-type: none"> <li>The CD is dirty.</li> </ul>	<ul style="list-style-type: none"> <li>Clean the CD with a soft, lint-free cloth.</li> </ul>
<ul style="list-style-type: none"> <li>The CD skips tracks.</li> </ul>	<ul style="list-style-type: none"> <li>The CD is damaged or dirty.</li> </ul>	<ul style="list-style-type: none"> <li>Replace or clean the CD.</li> </ul>
<ul style="list-style-type: none"> <li>Playback does not start from the first track.</li> </ul>	<ul style="list-style-type: none"> <li>PROGRAM or SHUFFLE activated.</li> </ul>	<ul style="list-style-type: none"> <li>Switch off SHUFFLE or clear programme.</li> </ul>
<ul style="list-style-type: none"> <li>No sound or bad sound.</li> </ul>	<ul style="list-style-type: none"> <li>Loose or wrong connections.</li> <li>Strong magnetic fields near the CD player.</li> </ul>	<ul style="list-style-type: none"> <li>Check connections.</li> <li>Find another place for the unit or change connections.</li> </ul>
<ul style="list-style-type: none"> <li>No sound or bad sound on headphones (CD720 only).</li> </ul>	<ul style="list-style-type: none"> <li>Level control set to - position.</li> <li>Headphones plug is dirty.</li> </ul>	<ul style="list-style-type: none"> <li>Set level control.</li> <li>Clean plug.</li> </ul>
<ul style="list-style-type: none"> <li>Remote control does not function (CD720 only).</li> </ul>	<ul style="list-style-type: none"> <li>Batteries are empty.</li> </ul>	<ul style="list-style-type: none"> <li>Replace the batteries.</li> </ul>
<ul style="list-style-type: none"> <li>Remote control commands are not properly received (CD720 only).</li> </ul>	<ul style="list-style-type: none"> <li>The distance between remote control and CD player is larger than 10 metres.</li> </ul>	<ul style="list-style-type: none"> <li>Use remote control receiver EIM 2200/2201.</li> <li>Reduce the distance between remote control and CD player.</li> </ul>

# ADDITIONAL INFORMATION

## MAINTENANCE

### The CDs

- Never write on the printed side of a CD.
- Do not attach any stickers to the CD.
- Keep the shiny surface of the disc clean.
- Use a soft lint-free cloth and always wipe the disc in a straight line from centre to edge.
- Never use cleaning agents for conventional records.
- Detergents or abrasive cleaning agents should not be used either.

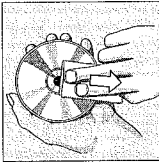

### The player

- A chamois leather slightly moistened with water is sufficient for cleaning the player.
- Do not use cleaning agents containing alcohol, spirits, ammonia or abrasives.

## RECYCLING

Please observe the local regulations regarding the disposal of packing materials, exhausted batteries and old equipment.

- All redundant packaging material has been omitted. We have done our utmost to make the packaging easy separable into three mono-materials:
  - cardboard (box)
  - expandable polystyrene (buffer)
  - polyethylene (bags, protective foam sheet)
- Your set consists of materials which can be recycled if disassembled by a specialized company.
- Do not dispose of exhausted batteries with your household waste.

## TECHNICAL DATA

**Typical Audio Performance**

Frequency range:	2 Hz - 20 kHz
Amplitude linearity:	0.3 dB (20 Hz - 20 kHz)
Phase linearity:	4° (20 Hz - 20 kHz)
Dynamic range:	90 dB (1 kHz)
Signal-to-noise ratio:	90 dB (1 kHz)
Channel separation:	90 dB (1 kHz)
Total harmonic distortion:	0.003% (1 kHz)
Audio output level:	2 Vrms
Impedance PHONES socket (CD720 only):	30 - 600 ohms

### Power supply

Mains voltage and frequency: see the type plate on the rear of the player  
 Power consumption: < 10 W approx.  
 Safety requirements: IEC 65

### Cabinet

Material/finish: metal and polystyrene  
 Dimensions (w x h x d): 435 x 90 x 300 mm  
 Weight: 4 kg approx.

### Subject to modification

**This Compact Disc player complies with radio interference requirements as laid down in EC regulations.**

**(GB) WARNING**

All ICs and many other semi-conductors are susceptible to electrostatic discharges (ESD). Careless handling during repair can reduce life drastically.

When repairing, make sure that you are connected with the same potential as the mass of the set via a wrist wrap with resistance. Keep components and tools also at this potential.

ESD

**(NL) WAARSCHUWING**

Alle IC's en vele andere halfgeleiders zijn gevoelig voor electrostatische ontladingen (ESD).

Onzorgvuldig behandelen tijdens reparatie kan de levensduur drastisch doen verminderen. Zorg ervoor dat u tijdens reparatie via een polsband met weerstand verbonden bent met hetzelfde potentiaal als de massa van het apparaat.

Houd componenten en hulpmiddelen ook op ditzelfde potentiaal.

**(I) AVVERTIMENTO**

Tutti IC e parecchi semi-conduttori sono sensibili alle scariche statiche (ESD).

La loro longevità potrebbe essere fortemente ridotta in caso di non osservazione della più grande cauzione alla loro manipolazione. Durante le riparazioni occorre quindi essere collegato allo stesso potenziale che quello della massa dell'apparecchio tramite un braccialetto a resistenza.

Assicurarsi che i componenti e anche gli utensili con quali si lavora siano anche a questo potenziale.

**(F) ATTENTION**

Tous les IC et beaucoup d'autres semi-conducteurs sont sensibles aux décharges statiques (ESD).

Leur longévité pourrait être considérablement écourtée par le fait qu'aucune précaution n'est prise à leur manipulation.

Lors de réparations, s'assurer de bien être relié au même potentiel que la masse de l'appareil et enfiler le bracelet serti d'une résistance de sécurité.

Veiller à ce que les composants ainsi que les outils que l'on utilise soient également à ce potentiel.

**(D) WARNUNG**

Alle ICs und viele andere Halbleiter sind empfindlich gegen elektrostatische Entladungen (ESD).

Unvorsichtige Behandlung bei der Reparatur kann die Lebensdauer drastisch vermindern. Sorgen sie dafür, dass Sie im Reparaturfall über ein Pulsarmband mit Widerstand mit dem Massepotential des Gerätes verbunden sind. Halten Sie Bauteile und Hilfsmittel ebenfalls auf diesem Potential.

**(GB)**

Safety regulations require that the set be restored to its original condition and that parts which are identical with those specified be used.

**(NL)**

Veiligheidsbepalingen vereisen, dat het apparaat in zijn oorspronkelijke toestand wordt teruggebracht en dat onderdelen, identiek aan de gespecificeerde worden toegepast.

**(D)**

Bei jeder Reparatur sind die geltenden Sicherheitsvorschriften zu beachten. Der Originalzustand des Geräts darf nicht verändert werden für Reparaturen sind Original-Ersatzteile zu verwenden.

**(I)**

Le norme di sicurezza esigono che l'apparecchio venga rimesso nelle condizioni originali e che siano utilizzati pezzi di ricambio identici a quelli specificati.

**(F)**

Les normes de sécurité exigent que l'appareil soit remis à l'état d'origine et que soient utilisées les pièces de rechange identiques à celles spécifiées.



CLASS 3B

LASER PRODUCT

**CAUTION****VARO!****WARNING****ADVERSEL****DANGER****VORSICHT**

INVISIBLE LASER RADIATION WHEN OPEN AVOID EXPOSURE TO BEAM

AVATTAESSA OLET ALTTIINA NÄKYMÄTTÖMÄLLE LASER SÄTTEILYLLE ÄLÄ KATSO SÄTEESEN

OSYNLIG LASERSTRÅLNING NÄR DENNA DEL ÄR ÖPPNAD BETRakta EJ STRÅLEN

USYNLIG LASERSTRÅLING VED ÅBNING. UNDGÅ UNSAETTELSE FOR STRÅLING

INVISIBLE LASER RADIATION WHEN OPEN AVOID DIRECT EXPOSURE TO BEAM

UNSICHTBARE LASERSTRAHLUNG WENN ABDECKUNG GEÖFFNET NICHT DEM STRAHL AUSSETZEN

"Pour votre sécurité, ces documents doivent être utilisés par des spécialistes agréés, seuls habilités à réparer votre appareil en panne"

**CLASS 1  
LASER PRODUCT**

3127 110 03420

**SERVICING HINTS**

In the set chip components have been applied. For disassembly and assembly of chip components see the figure below.

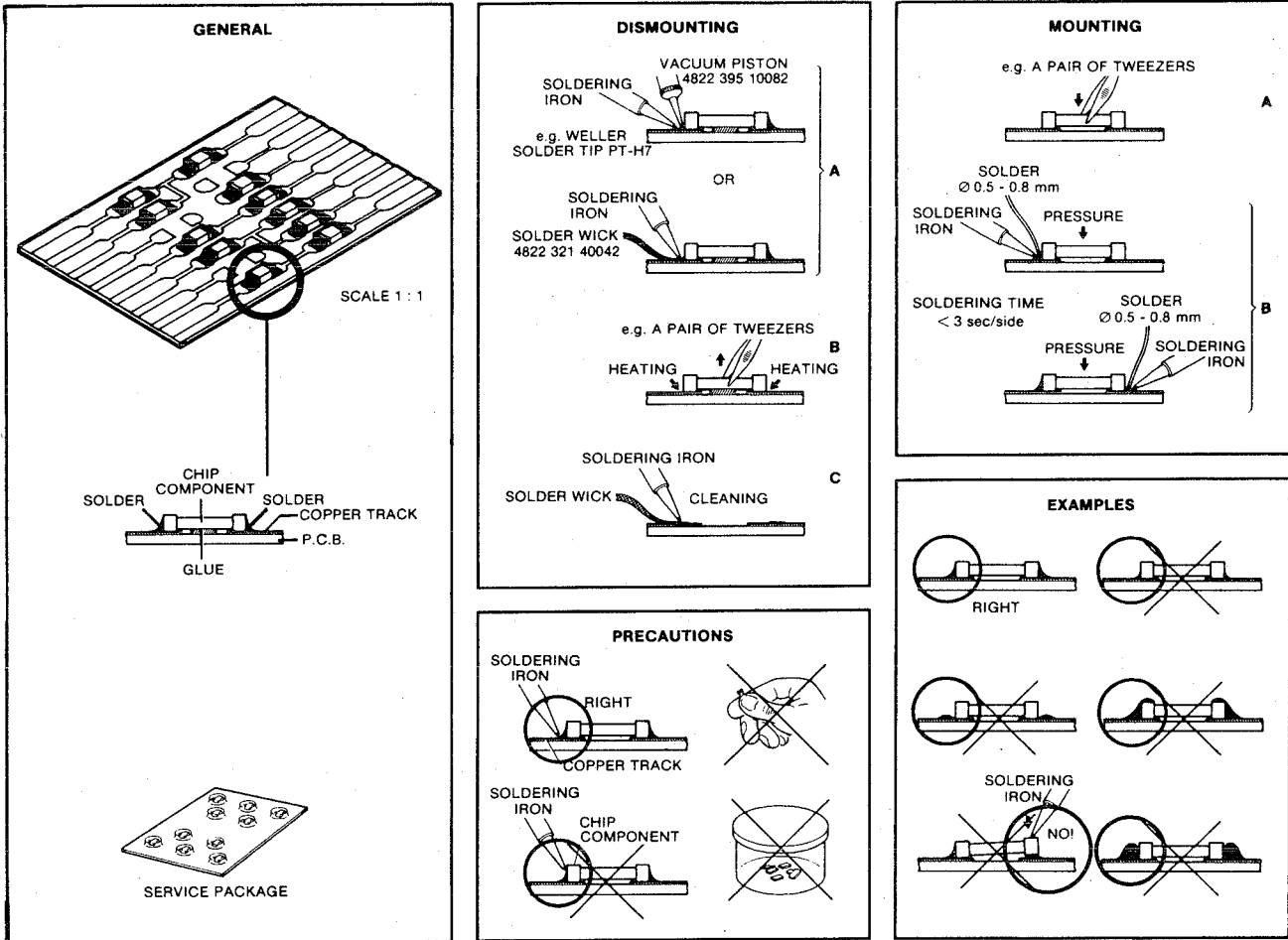

27 012C12

**SERVICE TOOLS**

Audio signal disc	4822 397 30184
Disc without errors (test disc 5) + disc with DO errors, black spots and fingerprints (test disc 5A)	4822 397 30096
Disc (65 min 1kHz) without pause	4822 397 30155
Max. diameter disc (58.0 mm)	4822 397 60141
Torx screwdrivers	
Set (straight)	4822 395 50145
Set (square)	4822 395 50132
13th order filter	4822 395 30204

## DISMANTLING INSTRUCTIONS

OPEN EXPLODED VIEW ON PAGE 33

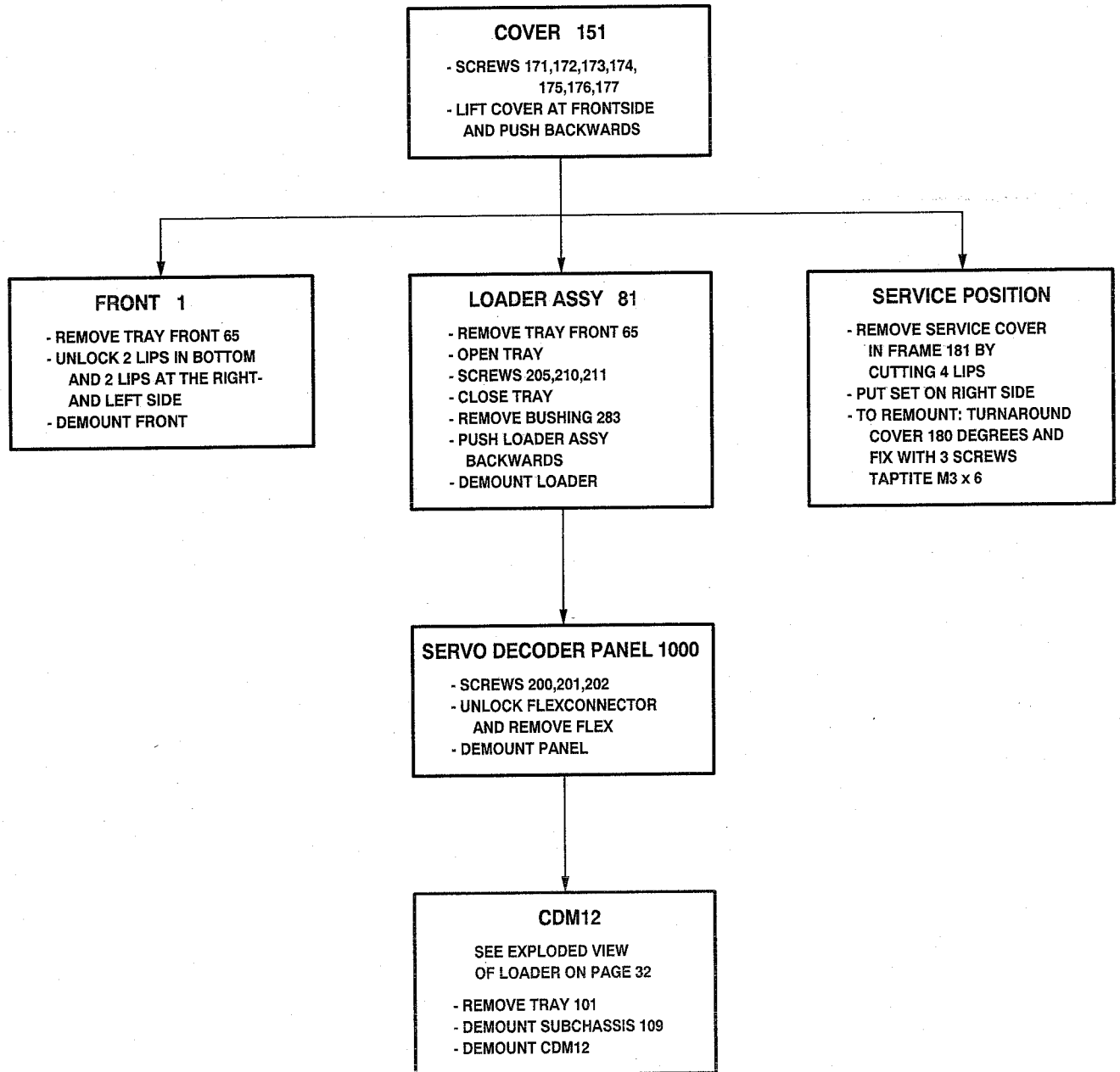

SERVICE TEST PROGRAM

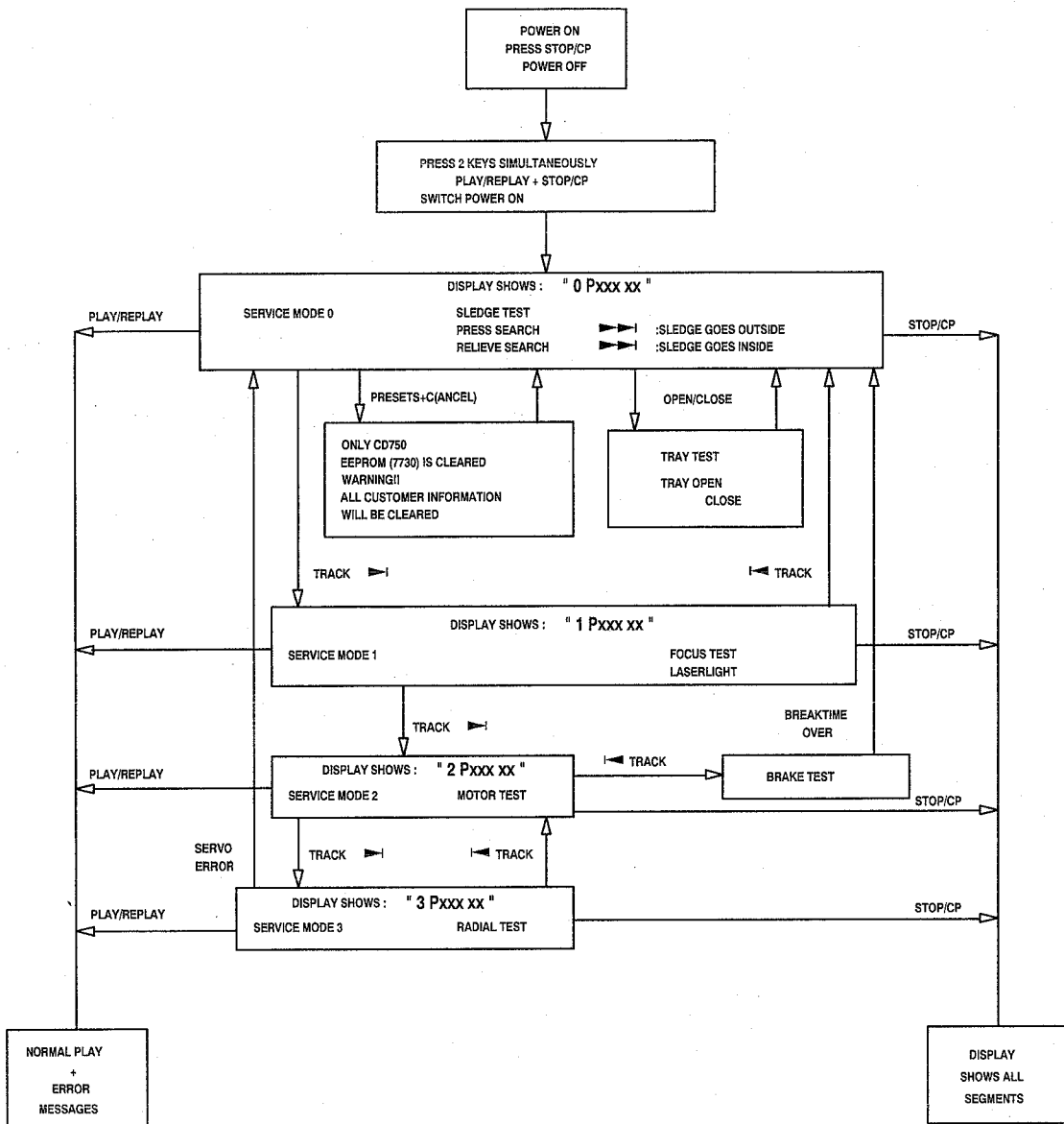

ERROR MESSAGES

- "SLEDGE ERROR"
- "FOCUS ERROR"
- "RADIAL ERROR"
- "MOTOR ERROR"
- "EEP ER"
- "EEP OK"

Pxxx = PROGRAM OF MICROPROCESSOR  
xx = VERSION OF PROGRAM

HAS1120  
9342

CDM 12.1 start up diagram.

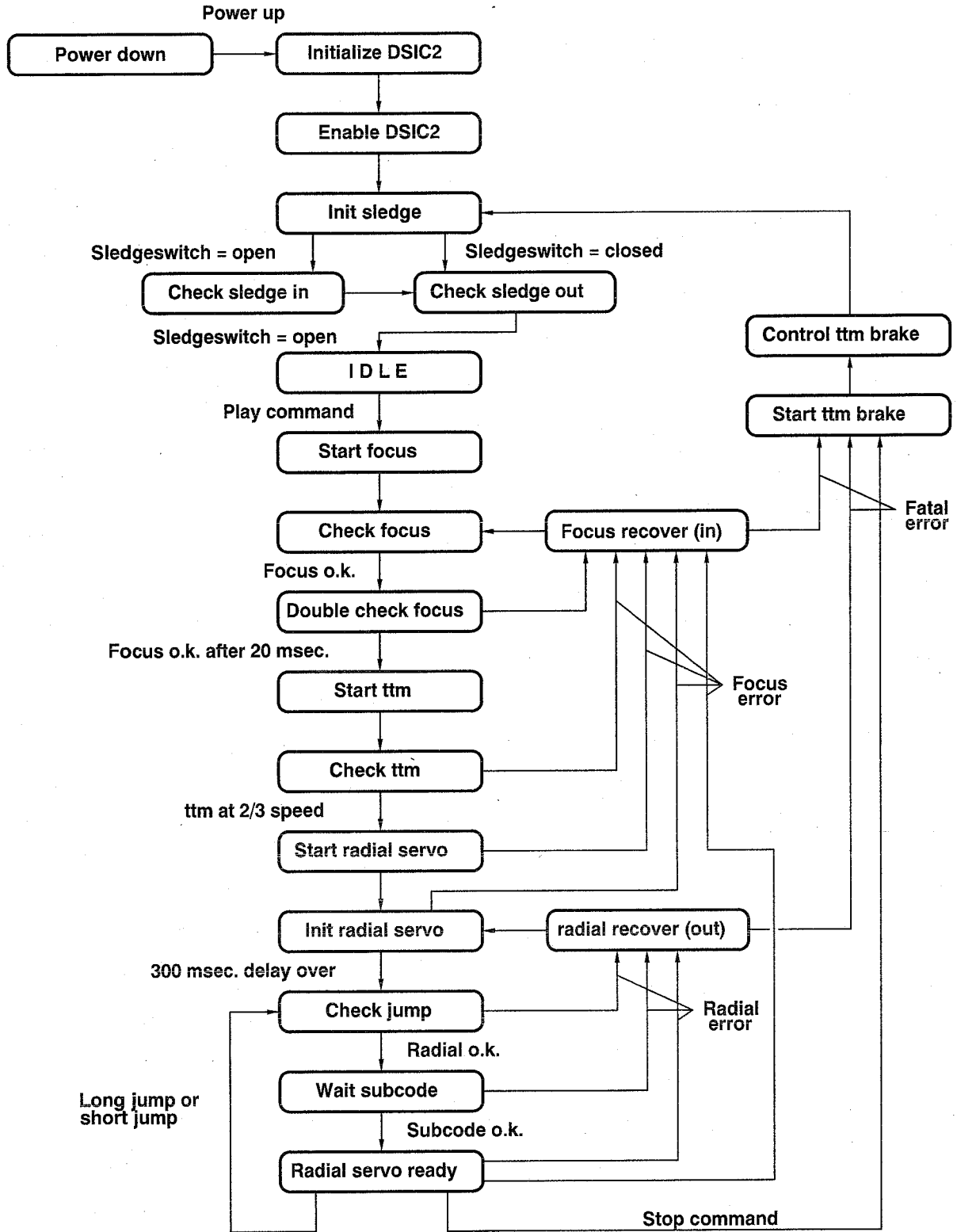

**FAULT FINDING GUIDE CDM 12.1**

Main Fault Finding Guide CDM 12.1  
System

Listen to kind of "scratching sound" while slowly turning the disc by hand.

Disc is turning clock wise at normal speed.

Activity on RAD+  
(pin 4 connector 1052)

\*After "play" starts at track 1 at time 0:00.  
\*Go to outer track and start again at time 0:00 after max. 6 seconds.

\*Try search function.

\*When going from "Pauze" to "play" music has to restart at the same place.

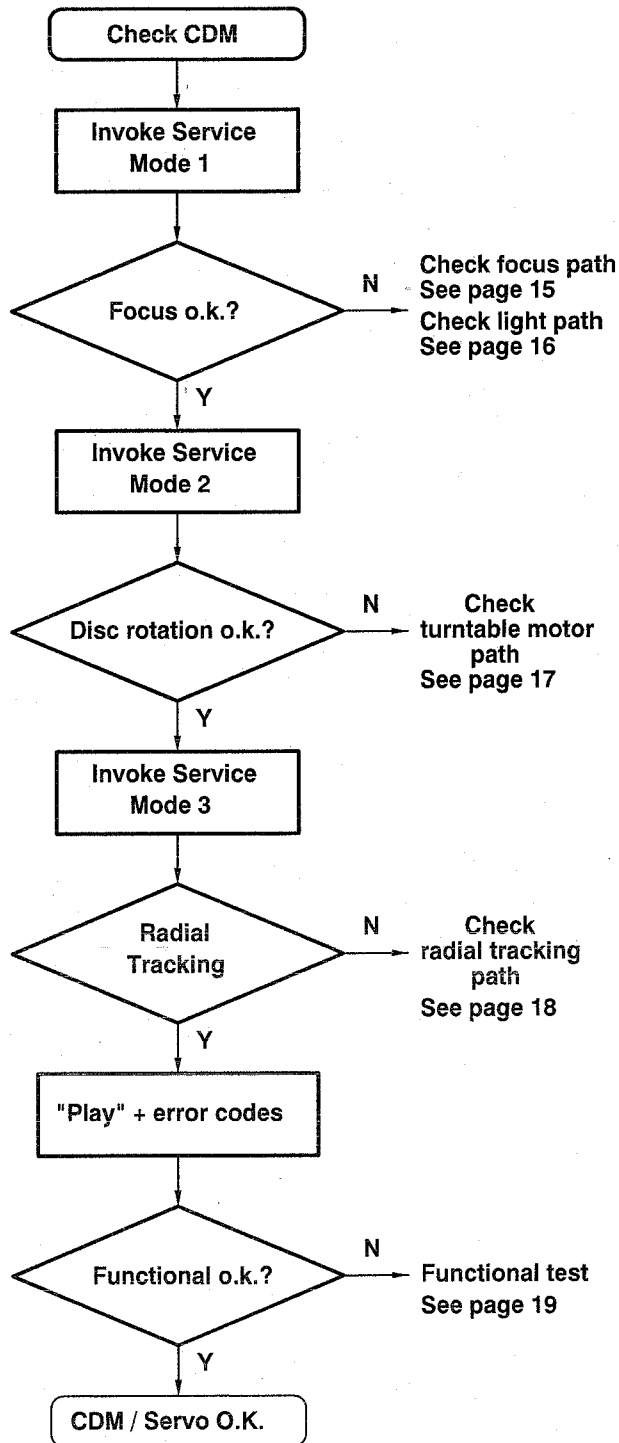



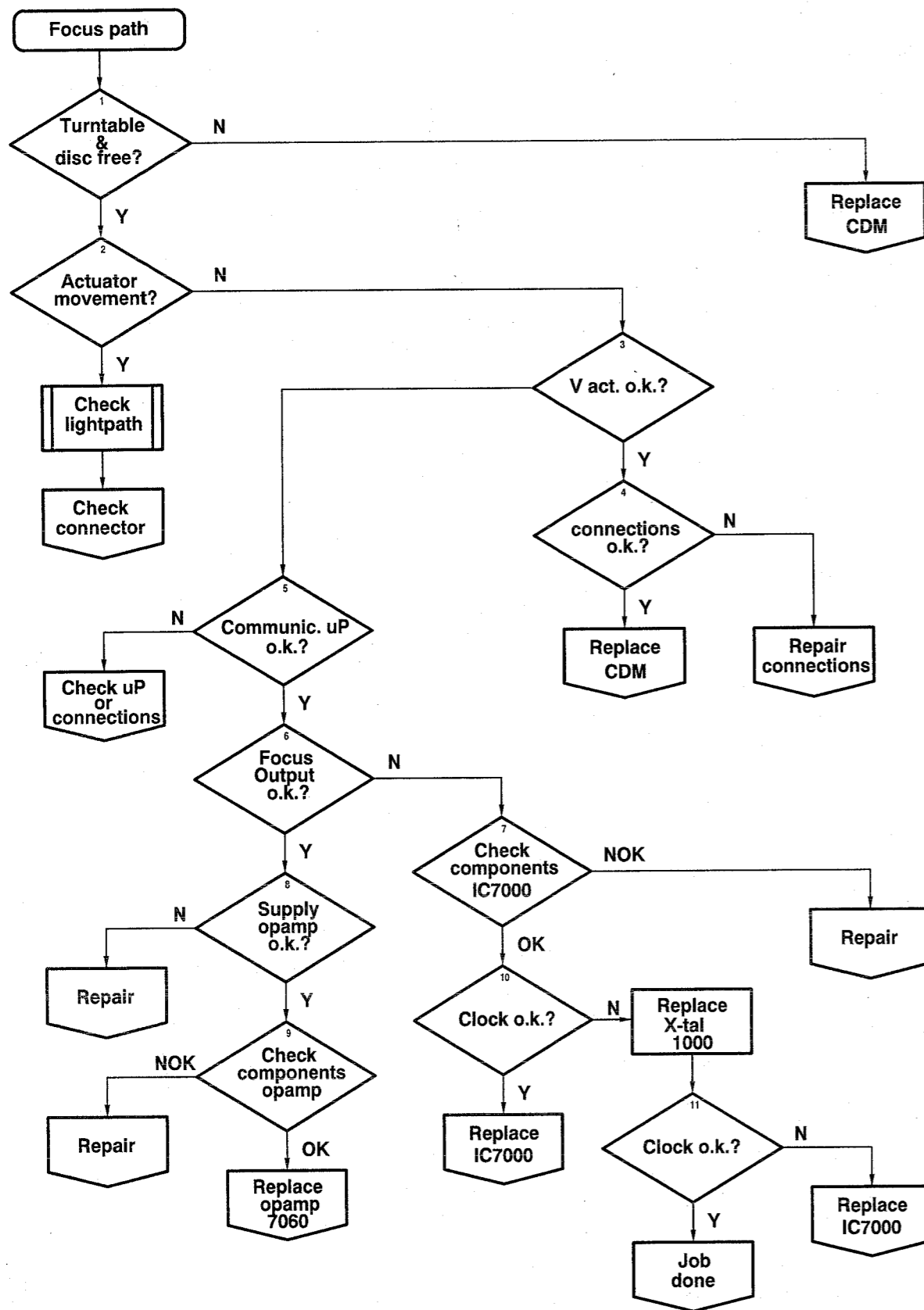

1)-Turntable and disc free?  
Audible and visible control.

2)-Actuator movement?  
Visual control.

3)-Signals on actuator o.k.?  
Triangle wave without disc.  
See fig 1.

4)-Connections to actuator o.k.?  
Check flex connector pin 2 and 3.

5)-Communication uP <-> IC7000.  
SIDA activity (pin 27 of IC7000).

6)-Focus output o.k.?  
See fig 2.  
Measure with an 10k/3n3 low-pass filter.

7)-Components o.k.?  
Check components R3010,R3011  
C2012,C2013  
X-tal 1000

8)-Power supply for opamp o.k.?  
Check components R3006,R3007  
C2008,C2009,C2071,C2074

9)-Check components o.k.?  
Check components R3074,R3075,R3076,R3077  
R3078,R3079  
C2075,C2076

10) & 11)-Pin 17 of IC7000: a frequency of 8.46MHz?

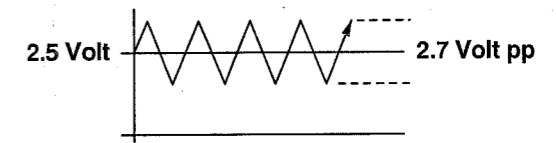
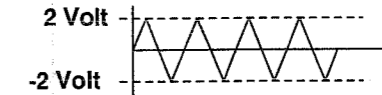

**WARNING !!! LASER DAMAGE !!!**

For measurements on the laser (flexconnector pin 1052-6), certain conditions are absolutely necessary for precaution of laser damage.

The instruction and sequence for measuring laser current is as follows:

- turn off mains power.
- wait for > 1 second
- connect a multimeter (high input impedance, not grounded across resistor 3022. (\*))
- turn on mains power and go to play mode.
- reading of measurement value (current = reading/4R7) (\*\*)
- go to stop and turn off mains power.
- disconnect the multimeter.

\* In case of a laser voltage measurement, connect the multimeter across elcap 2025, using the same procedure as mentioned above.

\*\* If current is > 95 mA, you can be sure that the laser is defect; If the current is increasing during reading (within +/- 10 seconds), you can be sure that the laser is severely damaged.

- \* 1)-Laser supply o.k.? Voltage across C2025: 4...5V
- \*\* 2)-Laser current o.k.? Voltage across R3022: 150...450mV
- 3)-Lens clean? Visual control. Check for dust,grease. Take attention for the blue coating.
- 4)-Check inputs. Switch back to service mode 0. Connect a 2.4 MOhm resistor from  
 1052 - 9 to 5V: Voltage on pin 5 of IC7000 < 50mV.  
 1052 - 10 to 5V: Voltage on pin 6 of IC7000 < 50mV.  
 1052 - 12 to 5V: Voltage on pin 7 of IC7000 < 50mV.  
 1052 - 11 to 5V: Voltage on pin 10 of IC7000 < 50mV.  
 1052 - 8 to 5V: Voltage on pin 11 of IC7000 < 50mV.
- 5)-Diodes o.k.? Use IR LED of remote control. A half sine wave must be measured on the diodes (on pin 8,9,10,11,12 of conn. 1052) in the 10mV range.
- \* 6)-V guard o.k.? Voltage across C2025: 4...5V
- 7)-Check connections between main PCB and CDM
- 8)-Flex o.k.? Measure diode functions on CDM-flex
- 9)-Check components around IC7061 R3022,R3021,R3020 C2025,C2060,C2064
- 10)-LD ON voltage o.k.? Measure on pin 2 of IC7000:4...5V.

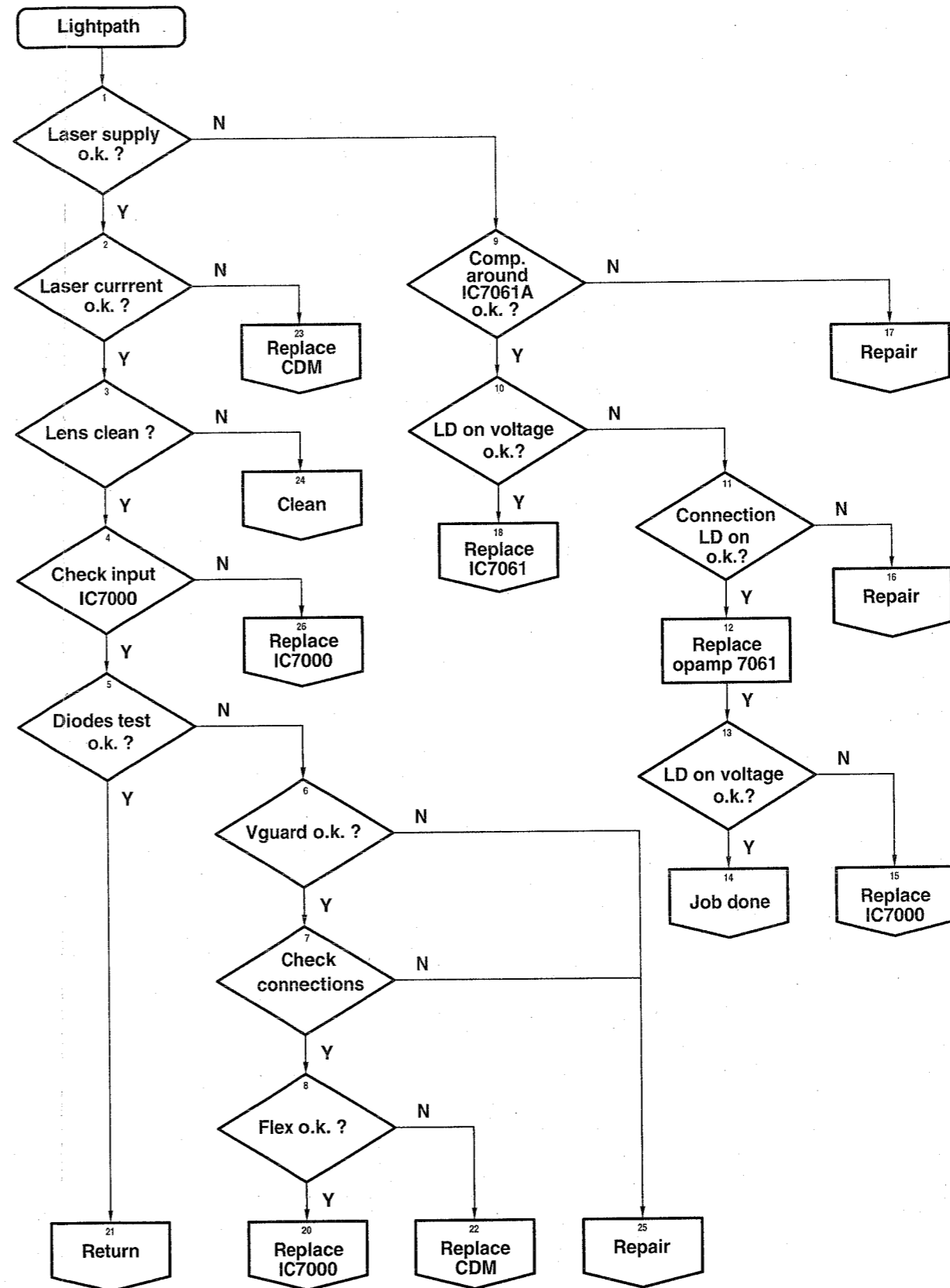

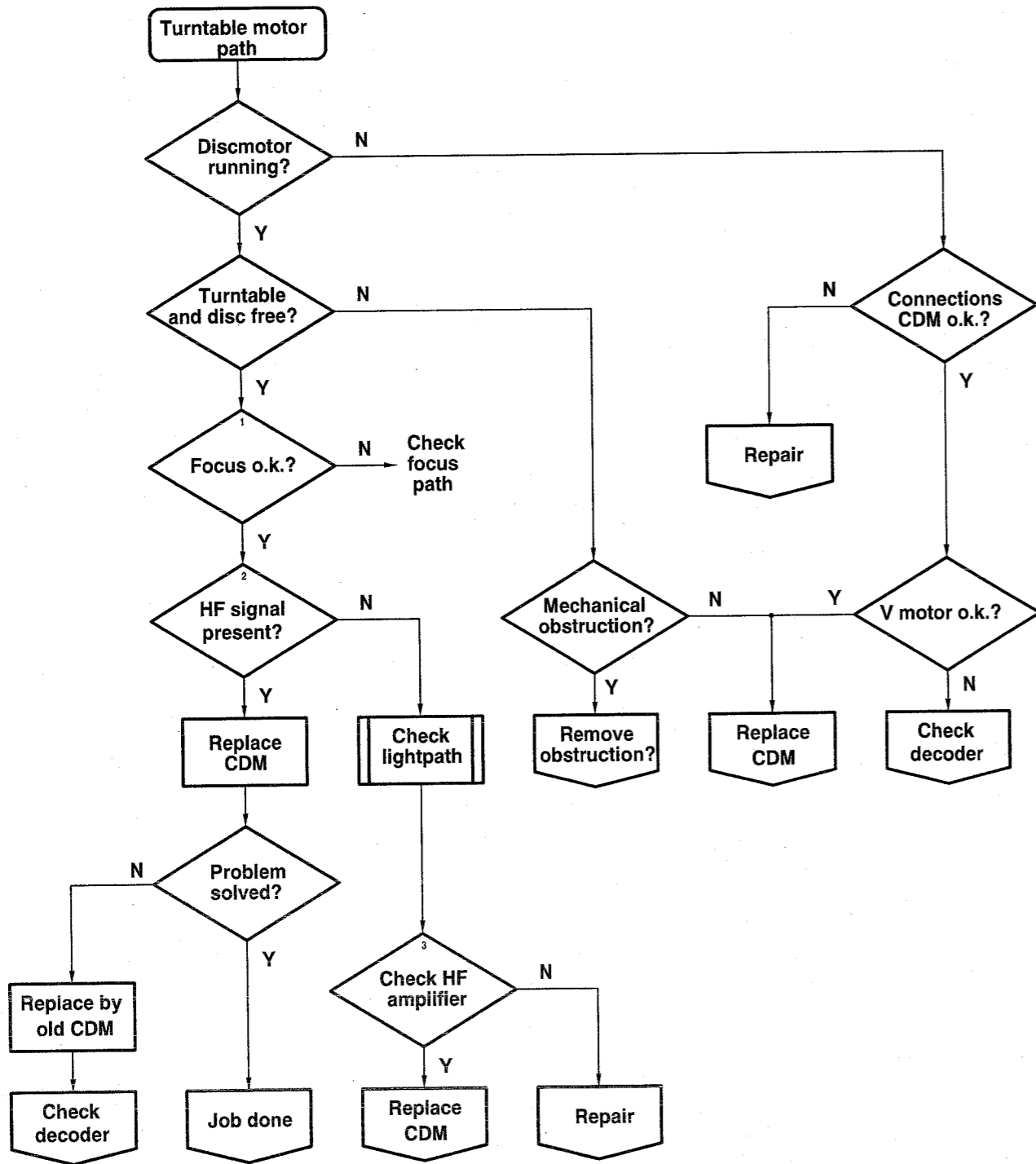

1)-Still in focus (focus o.k.?).  
Voltage at pin 9 of connector 1052 > 15mV.

2)-HF-signal present.  
VHFI (R3048) > 900mV pp. (testpoint 65).

3)-Check HF-amplifier.  
\* Supply 5V?  
\* Testpoint 17=1.4...1.9V DC?  
\* VHFI DC =2.9...3.6V?

4)-V motor o.k.?  
V motor < 2V: replace CDM.  
V motor > 2V: check decoder part.

- 1)-Radial tracking o.k?  
No OTD (testpoint 67) activity.
- 2)-Check driver 7060A.  
Supply: C2071,C2074.  
Components: C2067,C2068,C2069,R3068,R3069,R3070,R3071,R3072,R3073.
- 3)-Check connections radial actuator.  
Switch power off.  
Measure impedance of 18 Ohm(+/-20%) between pin 1 and pin 4 of connector 1052.
- 4)-Check impedance on flex.  
Power off.  
Disconnect CDM-flex.  
Measure impedance of 18 Ohm(+/-20%) between pin 1 and pin 4 of connector 1052.
- 5)-Test sledge.  
Power on.  
Invoke service mode 0.  
Move sledge out (with search forward key).  
Sledge moves to init position after releasing key.  
Not o.k. if sledge doesn't move,doesn't reach the outer position or makes a rattling noise at the inner side.
- 6)-Check driver 7061B.  
Supply: C2060,C2064.  
Components: C2062,C2063,C2066,R3060,R3062,R3064,R3065,R3066,R3067.
- 7)-Check connections of sledge drive.  
Power off.  
Measure impedance of 11 Ohm(+/-20%) between pin 5 and pin 6 of connector 1070.
- 8)-Check sledge motor.  
Remove CDM.  
Measure impedance of 11 Ohm(+/-20%) between motor terminals.

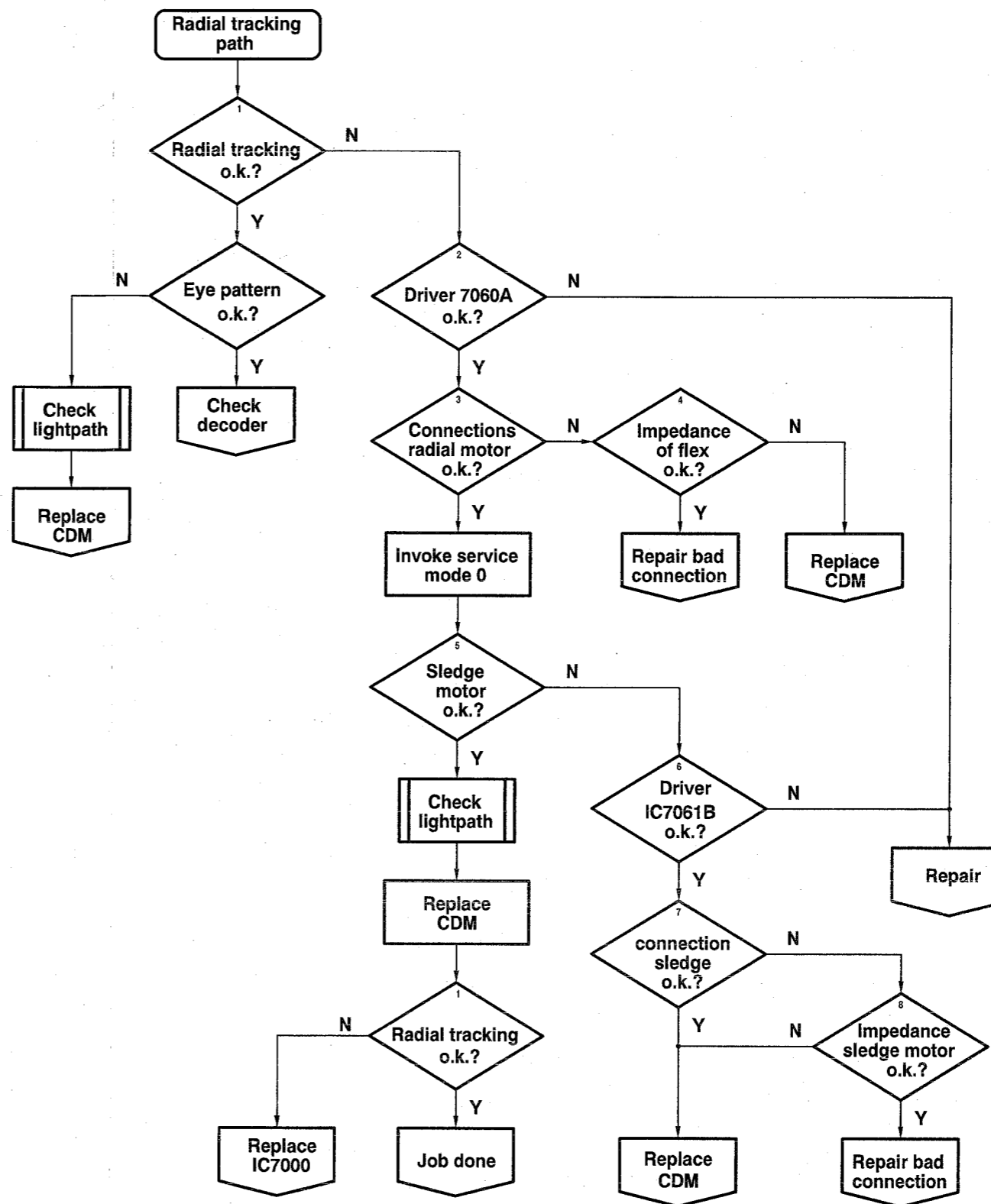

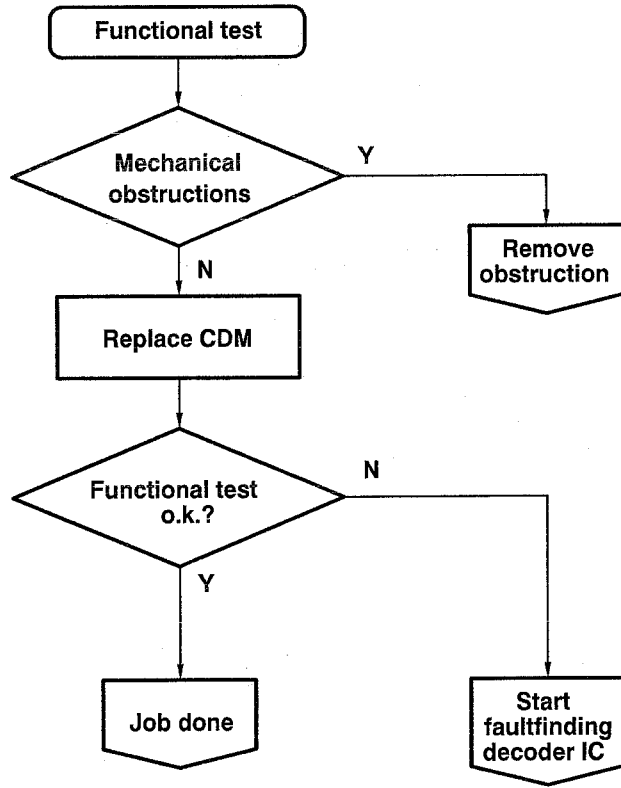

FAULTFINDING GUIDE

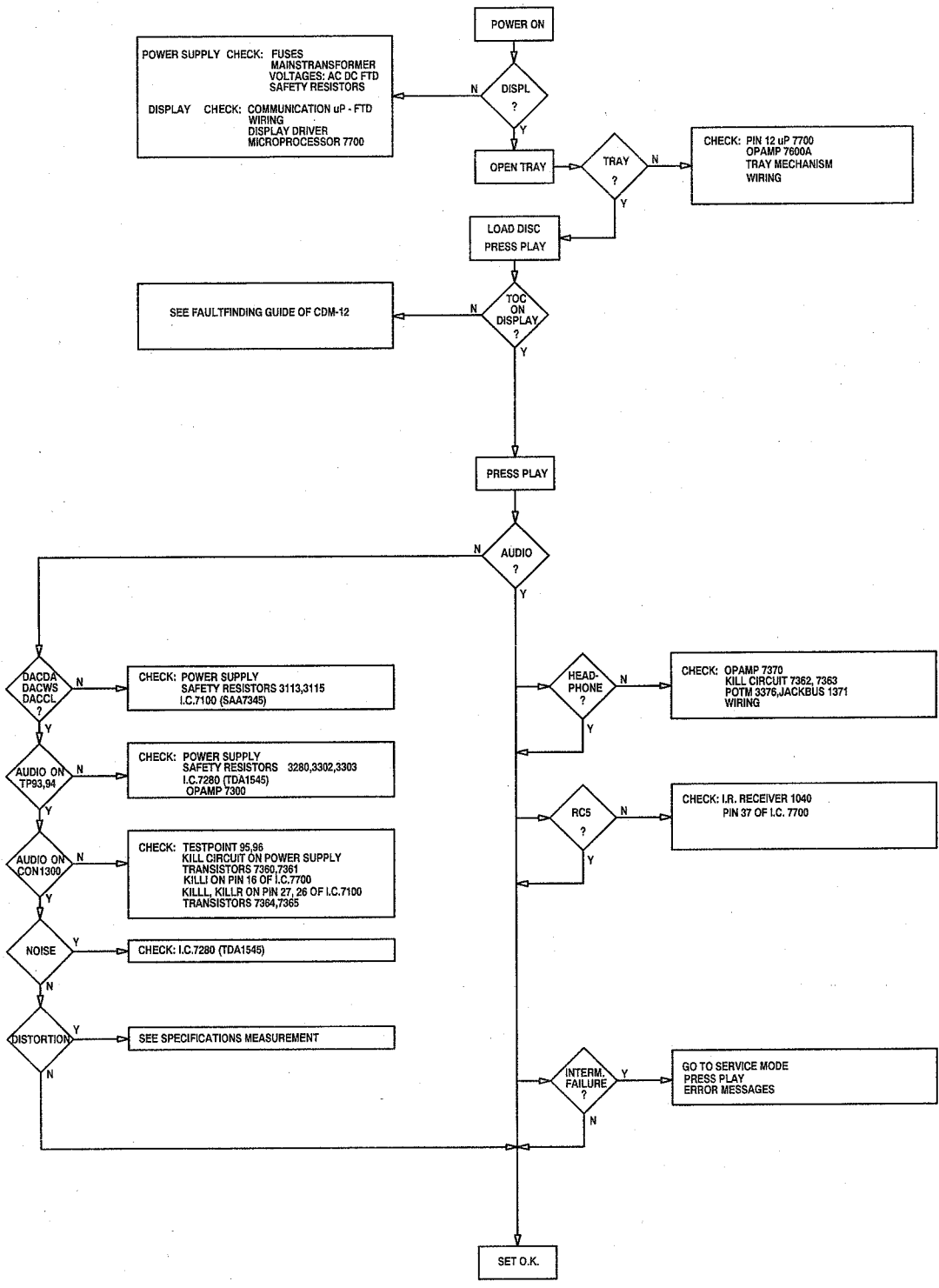

HAS1123  
9345

## SPECIFICATIONS MEASUREMENT

SIGNAL	AUDIO SIGNALS DISC 1	TESTPOINT	REMARKS
ANALOG OUT LEFT	TOTAL HARMONIC DISTORTION TRACKS 10 - 23	FILTER OUTPUT	SEE TECHNICAL DATA SEE DRAWING
ANALOG OUT RIGHT			
ANALOG OUT LEFT	SIGNAL-TO-NOISE RATIO TRACK 1 REFERENCE LEVEL TRACK 49	FILTER OUTPUT	SEE TECHNICAL DATA SEE DRAWING
ANALOG OUT RIGHT			

FILTER = 13TH ORDER FILTER 4822 395 30204

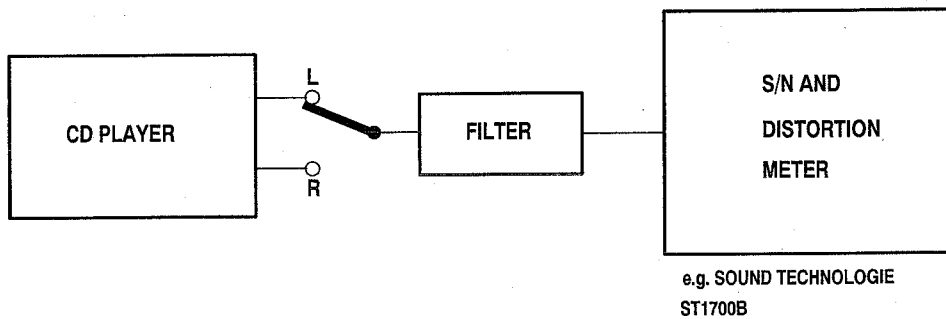

## ABBREVIATIONS

BCK	Bit clock input of CC-DAC TDA1545
CFLG	correction flag output
CL	interface clock input line
CL11	11.2896 MHz clock output
CL16	16.9344 MHz system clock output
CLA	4.2336 MHz microprocessor clock output
CLO	Clock output
CRIN	crystal/resonator input
CROUT	crystal/resonator output
D1-D4	Central diode input of TDA1301
D1-D5	Photodiode signals from CDM12 mechanism
DA	interface data I/O line
DACCL	Bit clock output of CD6 decoder SAA7345
DACDA	Data output of CD6 decoder SAA7345
DACWS	Word select output of CD6 decoder SAA7345
DATA	serial data output/Data input of CC-DAC TDA1545
DOBM	biphase mark output
FO	Focus actuator output
FOC+	+Connection of focus actuator
FOC-	Ground connection of focus actuator
HF	High-Frequency signal to decoder input
HFIN	comparator signal input
HFREF	comparator common-mode input
IOL	Left channel current output
IOR	Right channel current output
IREF	Reference current output
ISLICE	current feedback from data slicer
LDON	Laser drive on
MISC	general purpose DAC output
MOTO1	motor output 1
MOTO2	motor output 2
NRST	Reset input
OTD	Off track detector
PORE	power-on reset enable input(active low)
R1-R2	Satellite diode signal input
RA	Radial actuator output
RAB	interface R/W and acknowledge input
RAD+	+Connection of radial actuator
RAD-	Ground connection of radial actuator
SCLK	serial bit clock output
SICL	Serial interface clock
SIDA	Serial interface data
SILD	Serial interface load
SL OUT	+Connection of sledge motor
SL	Sledge output
TEST1	test input
TEST2	test input
TS1-TS2	Test inputs
V1-5	Versatile input pins
WCLK	Word clock output
WS	Word select input of CC-DAC TDA1545
XTLI	Oscillator input
XTLO	Oscillator output
XTLR	Oscillator reference



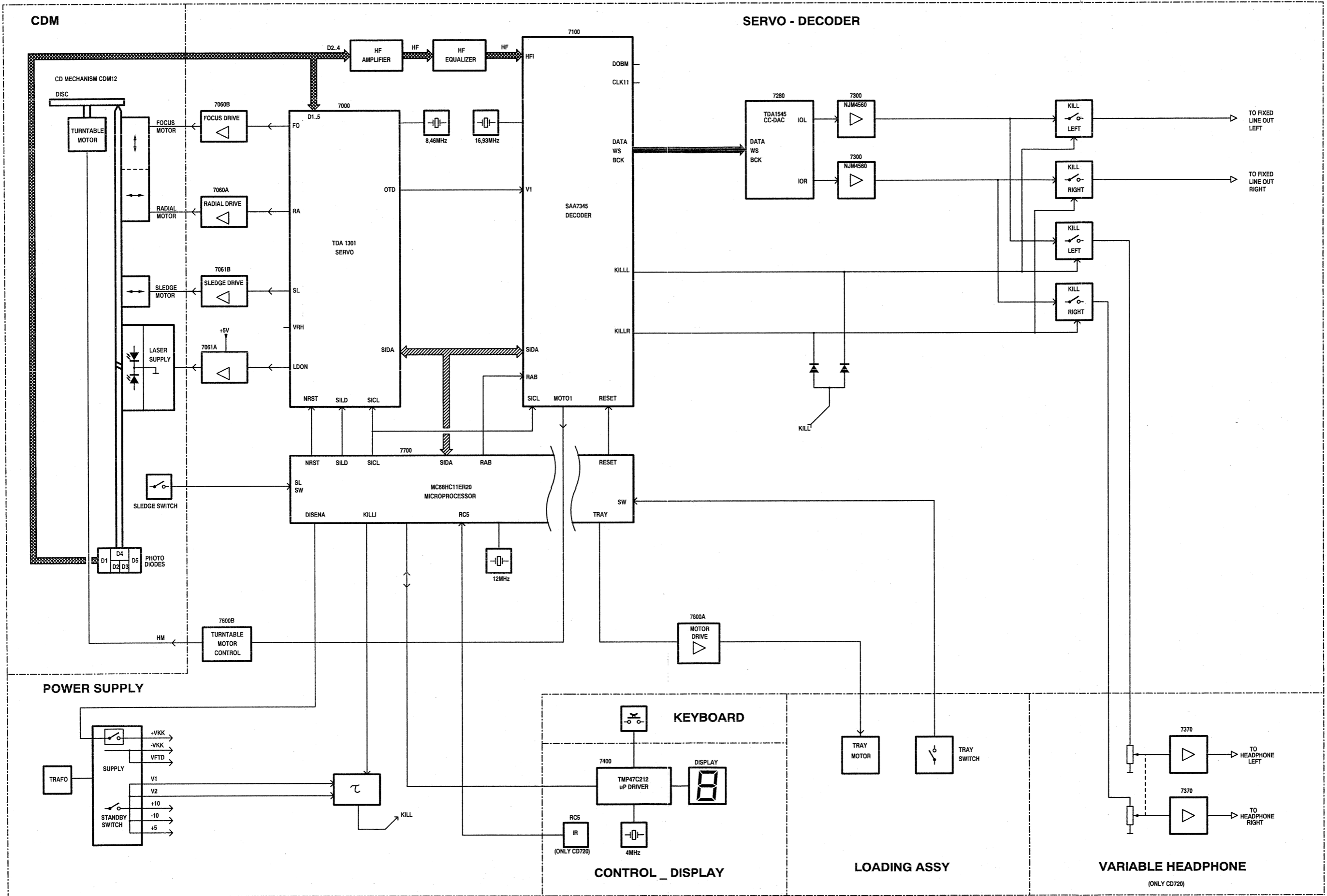

HAS1114  
9404

WIRING DIAGRAM

24

24

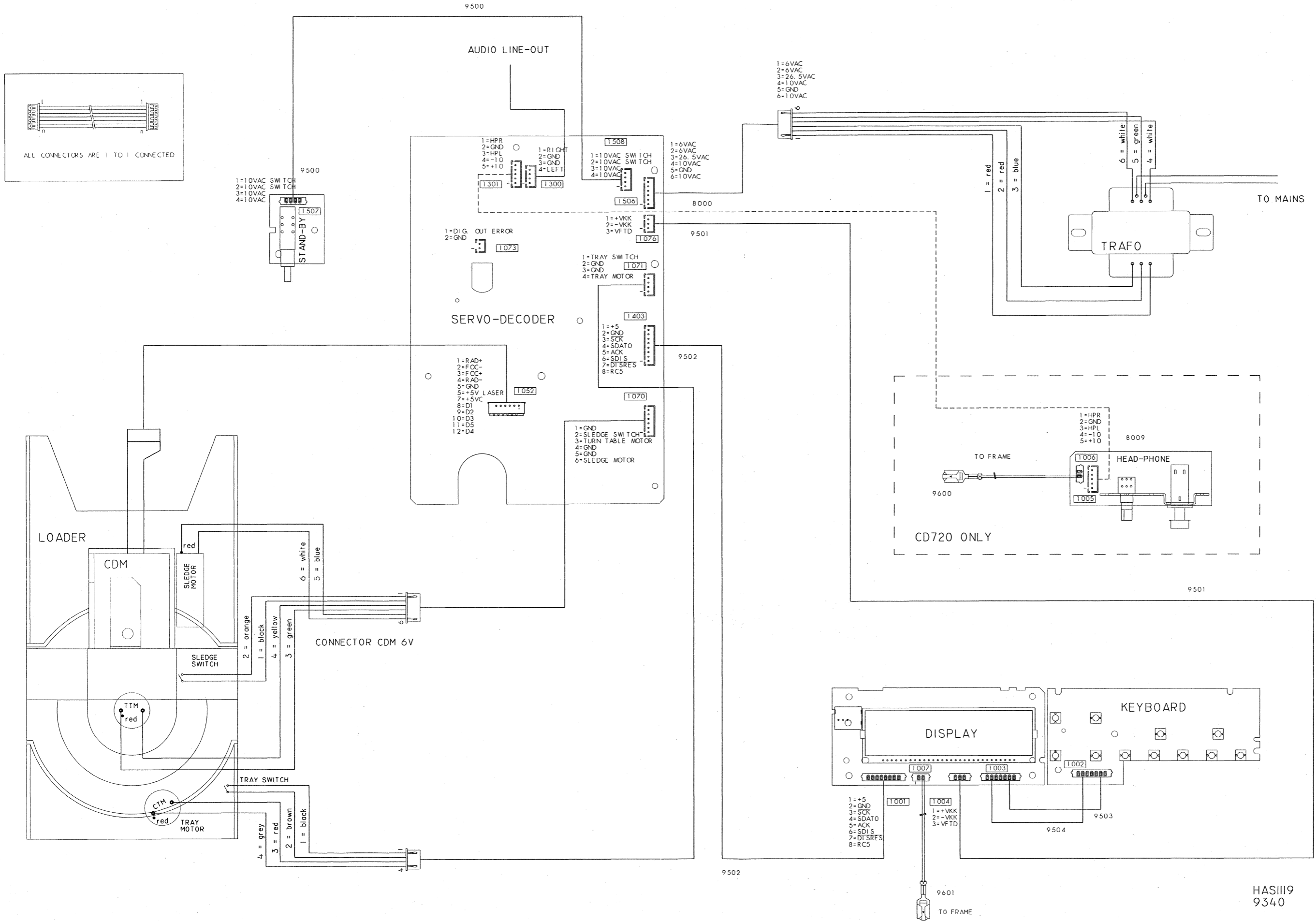

POWER SUPPLY CIRCUIT DIAGRAM

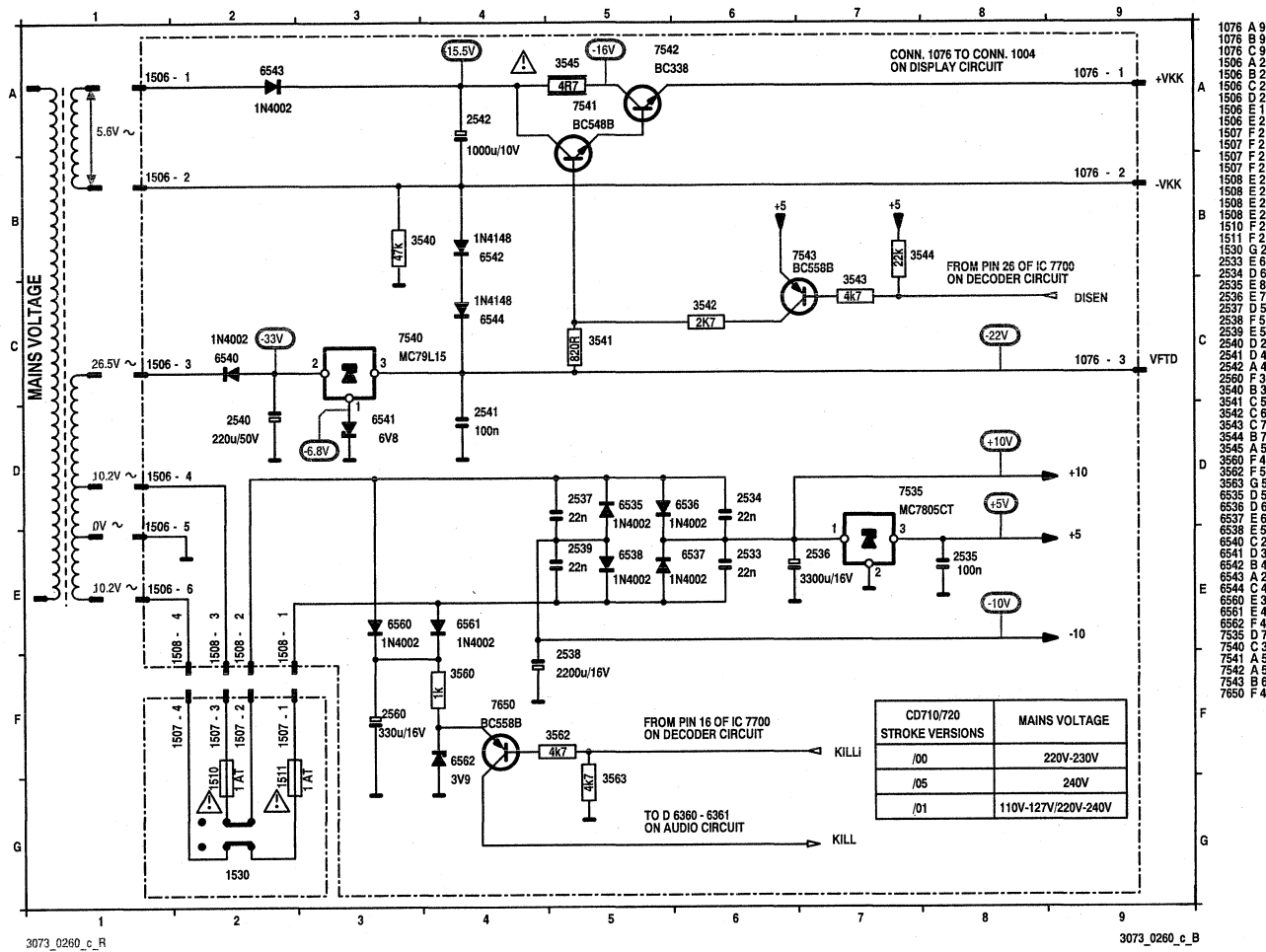

SWITCH PANEL

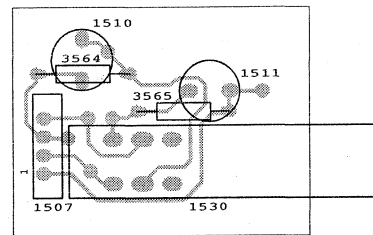

TRANSFORMER CONNECTIONS

/00/05/06/17 VERSIONS

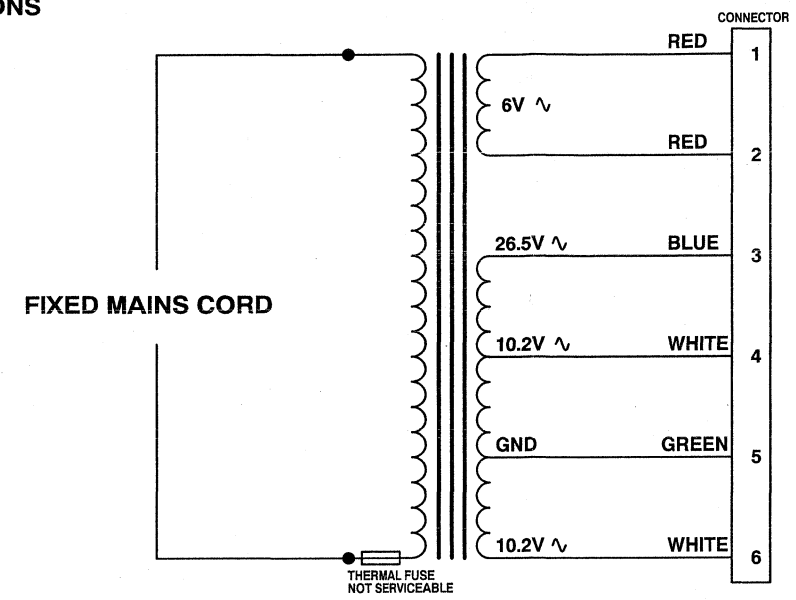

VERSION	MAINS VOLTAGE	SERVICE CODE
/00	220V-230V	4822 146 31337
/05	240V	4822 146 31339
/06	100V	4822 146 31345
/17	117V	4822 146 31341

/01 VERSION

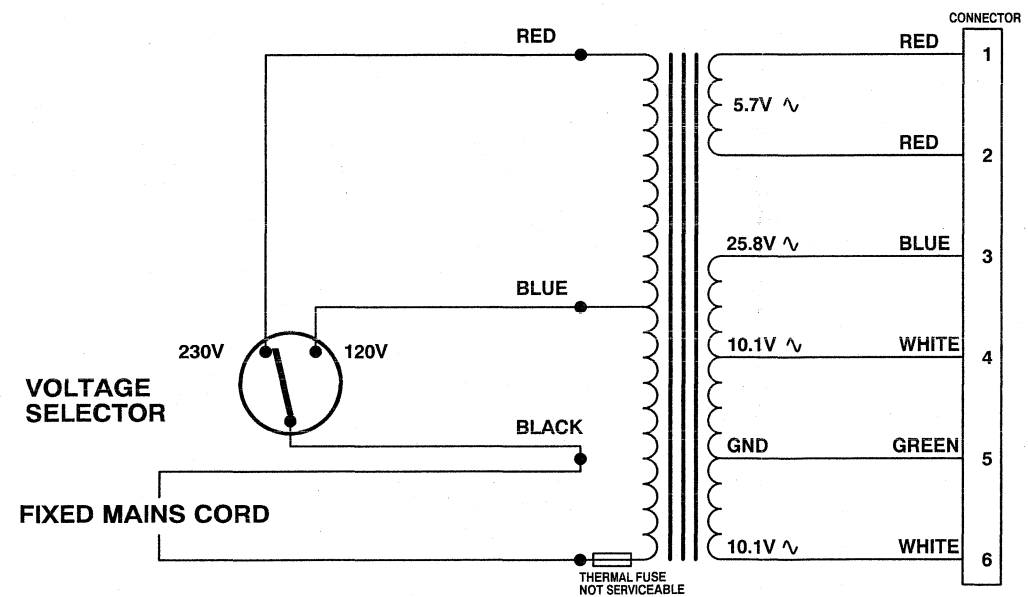

POSITION	MAINS VOLTAGE	SERVICE CODE
120V	110V-127V	4822 146 31338
230V	220V-240V	

TRANSFORMER AND VOLTAGE SELECTOR ARE ONE ASSEMBLY

SERVO CIRCUIT DIAGRAM

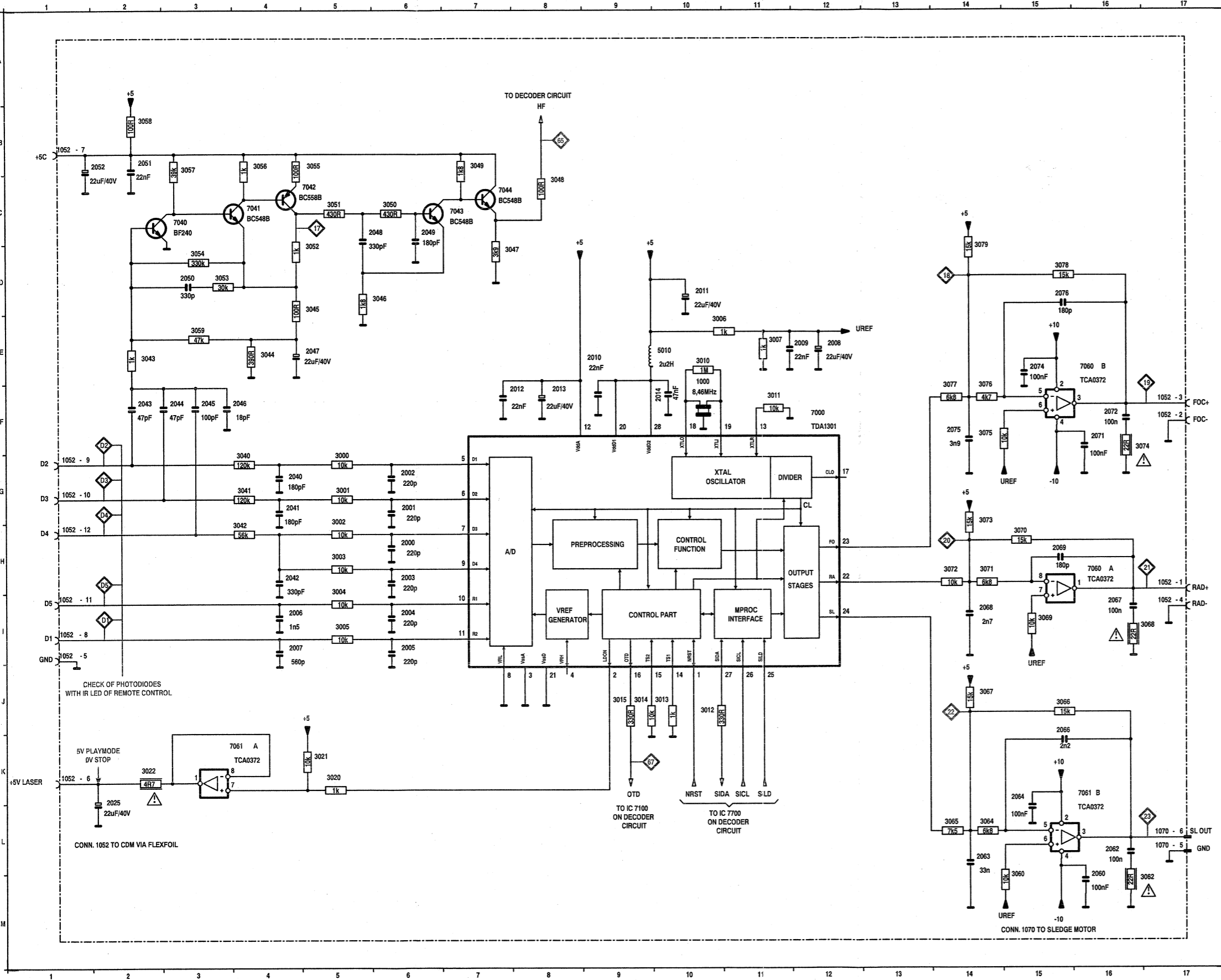

- 1000 E10
- 1052 H17
- 1052 F17
- 1052 G1
- 1052 H1
- 1052 K1
- 1052 B1
- 1052 G1
- 1052 G1
- 1052 H1
- 1070 L17
- 2000 H6
- 2001 G6
- 2002 G6
- 2003 H6
- 2004 I6
- 2005 I6
- 2006 I4
- 2007 I4
- 2008 E12
- 2009 E12
- 2010 E2
- 2011 D10
- 2012 F8
- 2013 F8
- 2014 F10
- 2025 K2
- 2040 G4
- 2041 G4
- 2042 H4
- 2043 F2
- 2044 F3
- 2045 F3
- 2046 F4
- 2047 E4
- 2048 C6
- 2049 C6
- 2050 D2
- 2051 B2
- 2052 B2
- 2060 M16
- 2062 L16
- 2063 L14
- 2064 K15
- 2066 J15
- 2067 H6
- 2068 H14
- 2069 H15
- 2071 F16
- 2072 F16
- 2074 E15
- 2076 F16
- 2076 D15
- 3000 G5
- 3001 G5
- 3002 G5
- 3003 H5
- 3004 H5
- 3005 I5
- 3006 E10
- 3007 E10
- 3010 E10
- 3011 F11
- 3012 J10
- 3013 J10
- 3014 J9
- 3015 J9
- 3020 K5
- 3021 K5
- 3022 K2
- 3040 G4
- 3041 G4
- 3042 H4
- 3043 E2
- 3044 E2
- 3045 D5
- 3046 D5
- 3047 D5
- 3048 C8
- 3049 B7
- 3050 C7
- 3051 C5
- 3052 D5
- 3053 D3
- 3054 D3
- 3055 B5
- 3056 B4
- 3057 B3
- 3058 B2
- 3059 E3
- 3060 M15
- 3062 M17
- 3064 L14
- 3065 L14
- 3066 H15
- 3067 J14
- 3068 H7
- 3069 H15
- 3070 H15
- 3071 H14
- 3072 H14
- 3073 G14
- 3074 F17
- 3075 F14
- 3076 F14
- 3077 F14
- 3078 D15
- 3079 D14
- 5010 E10
- 7000 F12
- 7040 C3
- 7041 C3
- 7042 C5
- 7043 C7
- 7044 C7
- 7060 H16
- 7060 E16
- 7061 K4
- 7061 K16

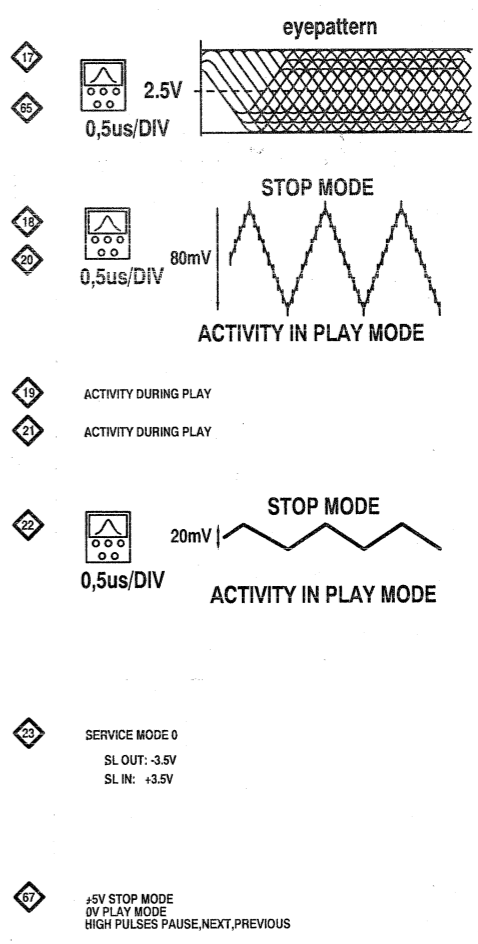

DECODER CIRCUIT DIAGRAM

9010	3702	9011	3703	3711	3712	3713	3714	7700	MOUNTED FOR
X		X		X	X			MC68HC11ER20B3	CD710
X		X		X	X			MC68HC11ER20B3	CD720
X		X	X				X	MC68HC11ER24B3	CD740
X		X		X	X		X	MC68HC11ER31B3	CD750
X		X	X				X	MC68HC11ER24B3	CD911
X		X	X				X	MC68HC11ER24B3	CD921

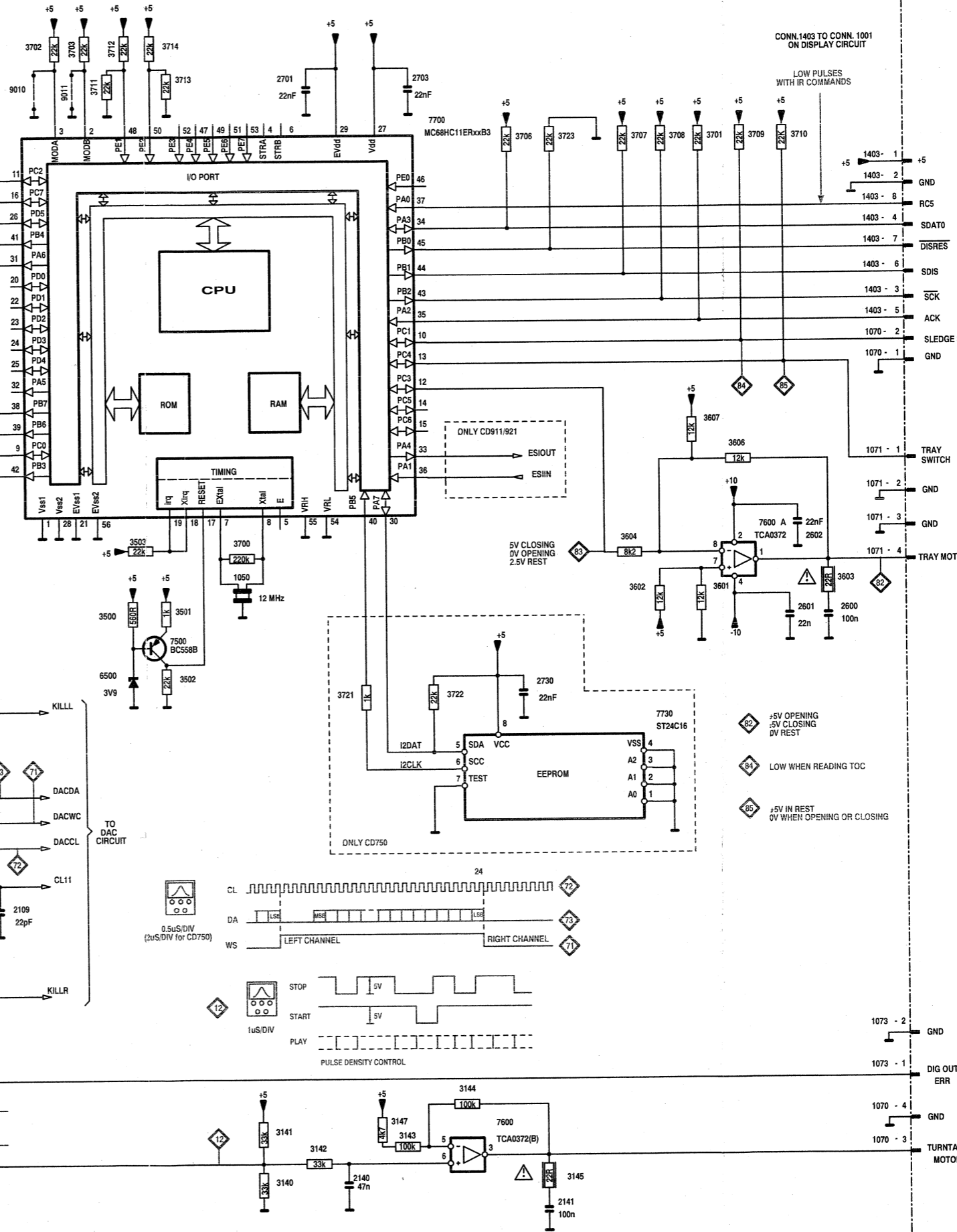

NOT USED  
TO POWER SUPPLY CIRCUIT  
ACTIVITY IN PLAY MODE  
TO IC 7000 ON SERVO CIRCUIT

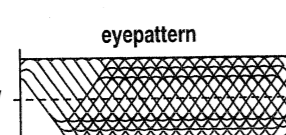

- ⬢ 5V OPENING  
5V CLOSING  
0V REST
- ⬢ LOW WHEN READING TOC
- ⬢ 5V IN REST  
0V WHEN OPENING OR CLOSING

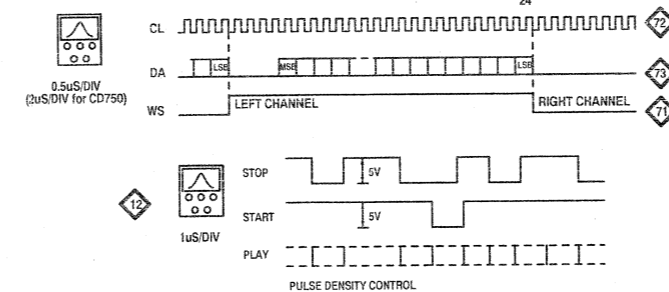

- 1050 H12
- 1070 E19
- 1070 N19
- 1070 M19
- 1071 F19
- 1071 G19
- 1071 M19
- 1073 M19
- 1101 M 6
- 1403 C19
- 1403 C19
- 1403 D19
- 1403 D19
- 1403 C19
- 2100 G 2
- 2101 G 4
- 2102 H 5
- 2103 H 3
- 2105 H 7
- 2109 K 9
- 2110 M 8
- 2111 M 9
- 2112 M 7
- 2113 M 6
- 2114 M 6
- 2115 B 4
- 2116 I 2
- 2118 M 5
- 2140 C13
- 2141 O16
- 2142 M 4
- 2600 H19
- 2601 H19
- 2602 G19
- 2701 B13
- 2703 B14
- 2730 I16
- 3100 G 3
- 3101 G 3
- 3107 H 6
- 3108 H 7
- 3109 J 9
- 3110 J 9
- 3111 K 9
- 3112 L 8
- 3114 L 6
- 3115 H 2
- 3116 L 6
- 3117 L 7
- 3140 O12
- 3141 N12
- 3142 N13
- 3143 N14
- 3144 N15
- 3145 O16
- 3146 L 4
- 3147 N14
- 3500 H10
- 3501 H11
- 3502 H11
- 3503 G11
- 3601 H18
- 3602 H17
- 3603 H19
- 3604 G16
- 3606 F18
- 3607 F17
- 3700 G12
- 3701 B18
- 3702 A10
- 3703 A10
- 3706 B15
- 3707 B17
- 3708 B17
- 3709 B18
- 3710 B19
- 3711 B10
- 3712 A11
- 3713 B11
- 3714 A11
- 3715 B16
- 3716 D 8
- 3717 C 8
- 3718 E 9
- 3719 E 9
- 3720 F 9
- 3721 H 3
- 3722 I15
- 3723 B16
- 5100 M 6
- 5500 I10
- 7100 H 8
- 7500 H11
- 7500 G18
- 7600 N15
- 7700 B14
- 7730 I17
- 9010 B 9
- 9011 B10

### DAC CIRCUIT DIAGRAM

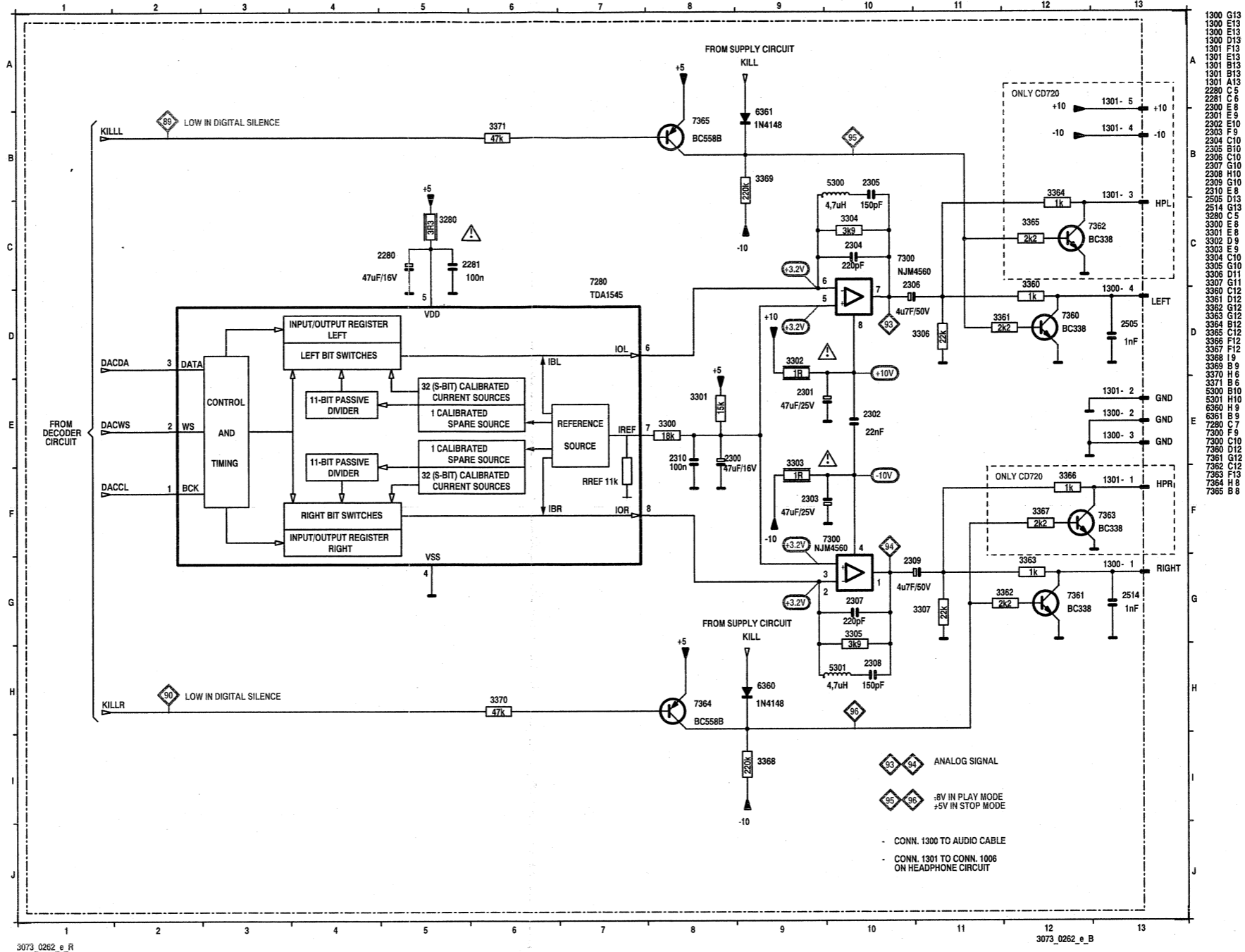

3073\_0262\_e\_R

3073\_0262\_e\_B

MAIN PANEL COMPONENT SIDE

1076 D 5	2533 C 5	3360 B 5	3563 C 4	7361 B 5	9208 C 5	2006 B 1	2050 A 1	2105 A 4	3001 B 1	3044 A 1	3066 D 1	3111 A 3	3602 B 3	3717 D 2	7600 C 4	9017 C 3	9037 D 2	9064 C 1
1300 B 5	2534 C 5	3361 B 5	5300 A 5	7362 B 5	9209 C 4	2007 B 1	2051 B 2	2109 B 3	3002 B 1	3045 A 1	3067 D 1	3112 B 3	3603 C 4	3718 D 2	7700 D 3	9018 C 3	9039 D 4	9065 C 1
1301 B 5	2535 C 5	3362 B 5	5301 A 4	7363 B 5	9210 C 4	2008 C 2	2052 A 2	2110 A 2	3003 B 1	3046 A 1	3068 B 1	3113 A 2	3604 C 3	3719 C 4	7730 D 2	9019 B 3	9040 C 4	9066 C 1
1506 D 5	2536 D 5	3363 B 5	6360 B 5	7364 B 5	9211 A 5	2009 C 2	2060 D 1	2111 A 3	3004 B 1	3047 A 2	3069 C 3	3114 A 3	3606 C 4	3720 B 4	9000 A 2	9020 B 3	9041 C 2	9067 D 2
1508 D 5	2537 C 5	3364 B 5	6361 B 5	7365 B 5	9212 A 5	2010 C 1	2062 D 1	2112 A 3	3005 B 1	3048 A 2	3070 C 2	3115 B 2	3607 C 3	3721 D 2	9001 D 1	9021 C 4	9042 D 2	9068 D 1
2280 A 5	2538 D 5	3365 B 5	6535 D 5	7535 C 5	-----	2011 C 2	2063 D 1	2113 A 3	3006 C 2	3049 A 2	3071 C 2	3116 B 4	3700 C 3	3722 D 2	9002 C 1	9022 B 3	9043 C 4	9134 D 2
2281 A 5	2539 C 5	3366 B 5	6536 D 5	7540 C 5	1000 C 1	2012 C 1	2064 D 1	2114 A 3	3007 C 2	3050 A 1	3072 C 1	3117 A 3	3701 D 4	3723 D 3	9003 A 4	9023 B 4	9044 C 3	9135 D 2
2300 B 5	2540 C 5	3367 B 5	6537 D 5	7541 D 5	1050 C 3	2013 C 1	2066 D 1	2115 A 3	3010 C 1	3051 A 1	3073 D 1	3140 A 4	3702 C 4	5010 C 1	9004 B 2	9024 B 4	9045 D 1	9136 C 4
2301 A 5	2541 C 5	3368 B 5	6538 D 5	7542 D 5	1052 B 2	2014 C 1	2067 C 1	2116 B 2	3011 C 1	3052 A 1	3074 B 1	3141 A 4	3703 C 4	5100 A 3	9005 B 2	9025 B 4	9046 C 4	9137 C 3
2302 A 5	2542 D 5	3369 B 5	6540 D 5	7543 C 5	1070 D 1	2025 B 1	2068 C 1	2118 B 4	3012 C 1	3053 A 1	3075 C 3	3142 A 4	3706 D 4	6500 D 2	9006 D 1	9026 B 4	9047 C 2	
2303 A 5	2560 C 5	3370 A 4	6541 C 5	7650 D 5	1071 D 4	2040 B 1	2069 C 2	2140 A 4	3013 C 1	3054 A 1	3076 C 3	3143 B 4	3707 D 3	7000 C 1	9007 C 2	9027 B 4	9054 B 1	
2304 A 5	3280 B 5	3371 B 4	6542 D 5	9069 C 5	1073 B 4	2041 B 1	2071 B 2	2141 C 4	3014 C 1	3055 A 1	3077 C 1	3144 C 4	3708 D 3	7040 A 1	9008 A 4	9028 C 4	9055 C 1	
2305 A 5	3300 A 5	3540 C 5	6543 D 5	9200 B 5	1101 A 3	2042 B 1	2072 B 1	2142 A 4	3015 C 1	3056 A 1	3078 C 2	3145 C 4	3709 C 4	7041 A 1	9009 D 3	9029 C 4	9056 C 1	
2306 A 5	3301 B 5	3541 D 5	6544 D 5	9201 B 5	1403 D 3	2043 A 1	2074 C 2	2600 C 4	3020 D 1	3057 A 1	3079 C 1	3146 A 4	3710 D 4	7042 A 1	9010 C 4	9030 C 4	9057 A 4	
2307 A 5	3302 A 5	3542 C 5	6560 C 5	9202 B 4	2000 B 1	2044 A 1	2075 C 1	2601 C 4	3021 D 1	3058 B 2	3100 A 2	3147 B 4	3711 D 4	7043 A 2	9011 C 4	9031 C 4	9058 D 4	
2308 B 5	3303 B 5	3543 C 5	6561 C 5	9203 C 5	2001 B 1	2045 A 1	2076 C 3	2602 C 4	3022 D 1	3059 A 1	3101 B 2	3500 C 3	3712 D 4	7044 A 2	9012 C 1	9032 C 4	9059 C 2	
2309 A 5	3304 A 5	3544 C 4	6562 D 5	9204 B 5	2002 B 1	2046 A 1	2100 A 2	2701 D 2	3040 B 1	3060 C 2	3107 A 4	3501 C 3	3713 D 4	7060 B 3	9013 A 4	9033 D 4	9060 A 2	
2310 A 5	3305 A 5	3545 D 5	7280 A 5	9205 B 5	2003 B 1	2047 A 1	2101 B 3	2703 D 2	3041 B 1	3062 D 1	3108 A 4	3502 C 3	3714 D 4	7061 D 1	9014 C 3	9034 D 2	9061 A 4	
2505 B 5	3306 B 5	3560 D 5	7300 A 5	9206 A 5	2004 C 1	2048 A 1	2102 B 3	2730 D 2	3042 B 1	3064 D 1	3109 A 3	3503 C 3	3715 A 4	7100 A 3	9015 B 4	9035 D 3	9062 D 2	
2514 B 5	3307 A 5	3562 C 5	7360 B 5	9207 C 5	2005 B 1	2049 A 2	2103 B 3	3000 B 1	3043 A 1	3065 C 1	3110 A 3	3601 B 4	3716 C 1	7500 C 2	9016 A 2	9036 B 4	9063 D 2	

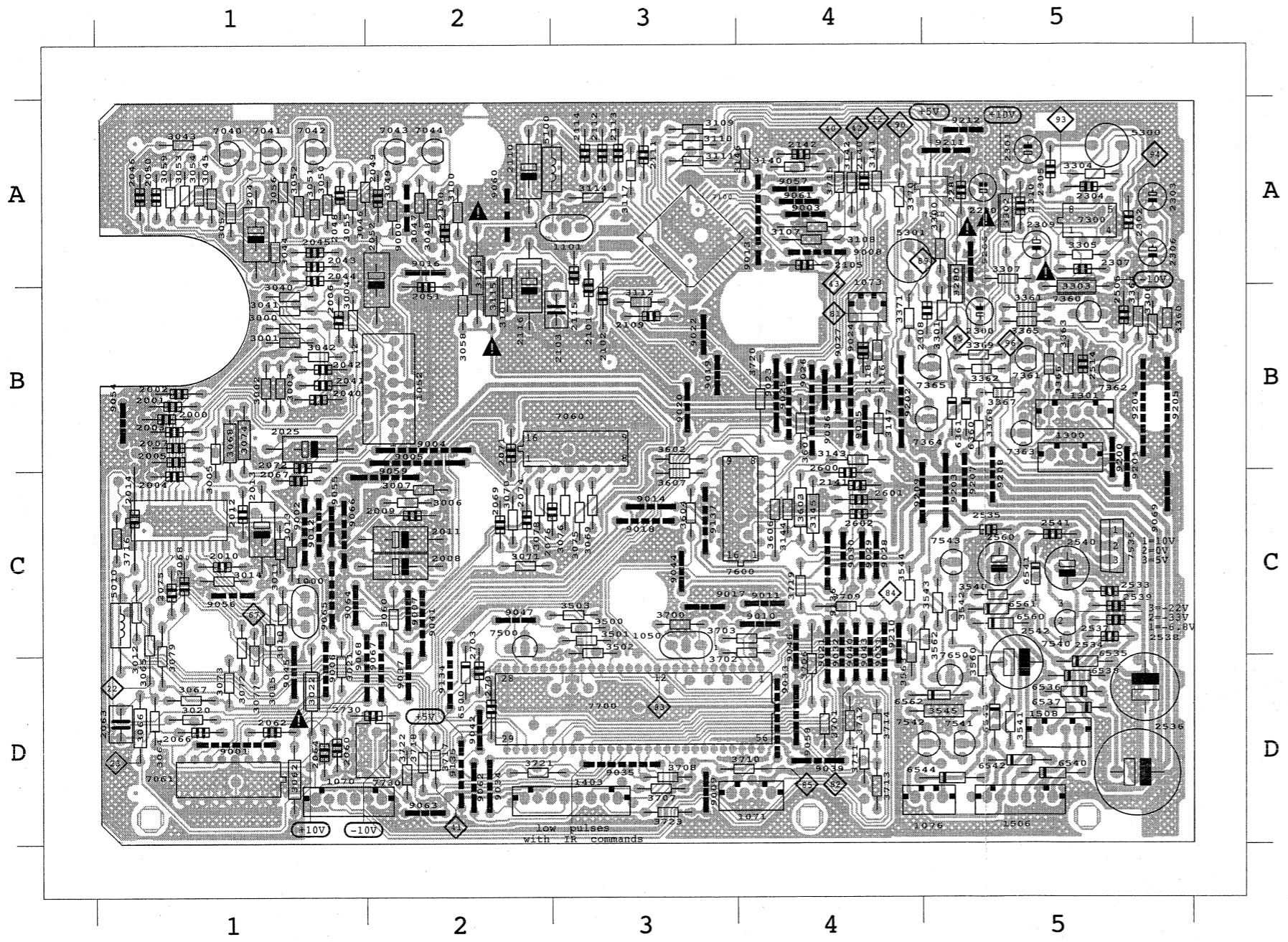

MAIN PANEL SOLDER SIDE

9064 C 1	9037 D 2	9017 C 3	7600 C 4	3717 D 2	3602 B 3	3111 A 3	3066 D 1	3044 A 1	3001 B 1	2105 A 4	2050 A 1	2006 B 1	9208 C 5	7361 B 5	3563 C 4	3360 B 5	2533 C 5	1076 D 5
9065 C 1	9039 D 4	9018 C 3	7700 D 3	3718 D 2	3603 C 4	3112 B 3	3067 D 1	3045 A 1	3002 B 1	2109 B 3	2051 B 2	2007 B 1	9209 C 4	7362 B 5	5300 A 5	3361 B 5	2534 C 5	1300 B 5
9066 C 1	9040 C 4	9019 B 3	7730 D 2	3719 C 4	3604 C 3	3113 A 2	3068 B 1	3046 A 1	3003 B 1	2110 A 2	2052 A 2	2008 C 2	9210 C 4	7363 B 5	5301 A 4	3362 B 5	2535 C 5	1301 B 5
9067 D 2	9041 C 2	9020 B 3	9000 A 2	3720 B 4	3606 C 4	3114 A 3	3069 C 3	3047 A 2	3004 B 1	2111 A 3	2050 D 1	2009 C 2	9211 A 5	7364 B 5	6360 B 5	3363 B 5	2536 D 5	1506 D 5
9068 D 1	9042 D 2	9021 C 4	9001 D 1	3721 D 2	3607 C 3	3115 B 2	3070 C 2	3048 A 2	3005 B 1	2112 A 3	2062 D 1	2010 C 1	9212 A 5	7365 B 5	6361 B 5	3364 B 5	2537 C 5	1508 D 5
9134 D 2	9043 C 4	9022 B 3	9002 C 1	3722 D 2	3700 C 3	3116 B 4	3071 C 2	3049 A 2	3006 C 2	2113 A 3	2063 D 1	2011 C 2	-----	7535 C 5	6535 D 5	3365 B 5	2538 D 5	2280 A 5
9135 D 2	9044 C 3	9023 B 4	9003 A 4	3723 D 3	3701 D 4	3117 A 3	3072 C 1	3050 A 1	3007 C 2	2114 A 3	2064 D 1	2012 C 1	1000 C 1	7540 C 5	6536 D 5	3366 B 5	2539 C 5	2281 A 5
9136 C 4	9045 D 1	9024 B 4	9004 B 2	5010 C 1	3702 C 4	3140 A 4	3073 D 1	3051 A 1	3010 C 1	2115 A 3	2066 D 1	2013 C 1	1050 C 3	7541 D 5	6537 D 5	3367 B 5	2540 C 5	2300 B 5
9137 C 3	9046 C 4	9025 B 4	9005 B 2	5100 A 3	3703 C 4	3141 A 4	3074 B 1	3052 A 1	3011 C 1	2116 B 2	2067 C 1	2014 C 1	1052 B 2	7542 D 5	6538 D 5	3368 B 5	2541 C 5	2301 A 5
	9047 C 2	9026 B 4	9006 D 1	6500 D 2	3706 D 4	3142 A 4	3075 C 3	3053 A 1	3012 C 1	2118 B 4	2068 C 1	2025 B 1	1070 D 1	7543 C 5	6540 D 5	3369 B 5	2542 D 5	2302 A 5
	9054 B 1	9027 B 4	9007 C 2	7000 C 1	3707 D 3	3143 B 4	3076 C 3	3054 A 1	3013 C 1	2140 A 4	2069 C 2	2040 B 1	1071 D 4	7650 D 5	6541 C 5	3370 A 4	2560 C 5	2303 A 5
	9055 C 1	9028 C 4	9008 A 4	7040 A 1	3708 D 3	3144 C 4	3077 C 1	3055 A 1	3014 C 1	2141 C 4	2071 B 2	2041 B 1	1073 B 4	9069 C 5	6542 D 5	3371 B 4	3280 B 5	2304 A 5
	9056 C 1	9029 C 4	9009 D 3	7041 A 1	3709 C 4	3145 C 4	3078 C 2	3056 A 1	3015 C 1	2142 A 4	2072 B 1	2042 B 1	1101 A 3	9200 B 5	6543 D 5	3540 C 5	3300 A 5	2305 A 5
	9057 A 4	9030 C 4	9010 C 4	7042 A 1	3710 D 4	3146 A 4	3079 C 1	3057 A 1	3020 D 1	2160 C 4	2074 C 2	2043 A 1	1403 D 3	9201 B 5	6544 D 5	3541 D 5	3301 B 5	2306 A 5
	9058 D 4	9031 C 4	9011 C 4	7043 A 2	3711 D 4	3147 B 4	3100 A 2	3058 B 2	3021 D 1	2601 C 4	2075 C 1	2044 A 1	2000 B 1	9202 B 4	6560 C 5	3542 C 5	3302 A 5	2307 A 5
	9059 C 2	9032 C 4	9012 C 1	7044 A 2	3712 D 4	3500 C 3	3101 B 2	3059 A 1	3022 D 1	2602 C 4	2076 C 3	2045 A 1	2001 B 1	9203 C 5	6561 C 5	3543 C 5	3303 B 5	2308 B 5
	9060 A 2	9033 D 4	9013 A 4	7060 B 3	3713 D 4	3501 C 3	3107 A 4	3060 C 2	3040 B 1	2701 D 2	2100 A 2	2046 A 1	2002 B 1	9204 B 5	6562 D 5	3544 C 4	3304 A 5	2309 A 5
	9061 A 4	9034 D 2	9014 C 3	7061 D 1	3714 D 4	3502 C 3	3108 A 4	3062 D 1	3041 B 1	2703 D 2	2101 B 3	2047 A 1	2003 B 1	9205 B 5	7280 A 5	3545 D 5	3305 A 5	2310 A 5
	9062 D 2	9035 D 3	9015 B 4	7100 A 3	3715 A 4	3503 C 3	3109 A 3	3064 D 1	3042 B 1	2730 D 2	2102 B 3	2048 A 1	2004 C 1	9206 A 5	7300 A 5	3560 D 5	3306 B 5	2505 B 5
	9063 D 2	9036 B 4	9016 A 2	7500 C 2	3716 C 1	3601 B 4	3110 A 3	3065 C 1	3043 A 1	3000 B 1	2103 B 3	2049 A 2	2005 B 1	9207 C 5	7360 B 5	3562 C 5	3307 A 5	2514 B 5

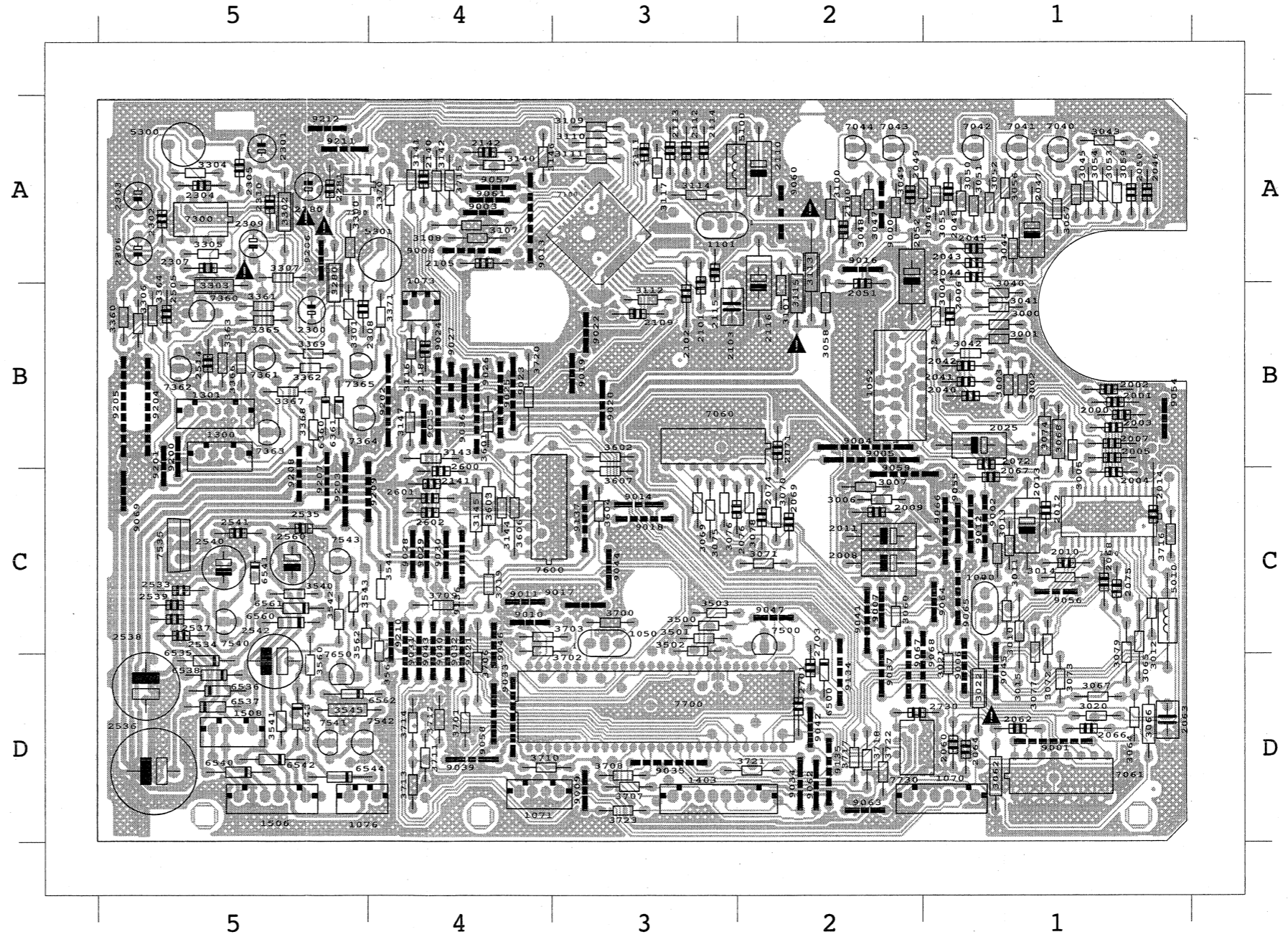



CONTROL AND DISPLAY CIRCUIT DIAGRAM

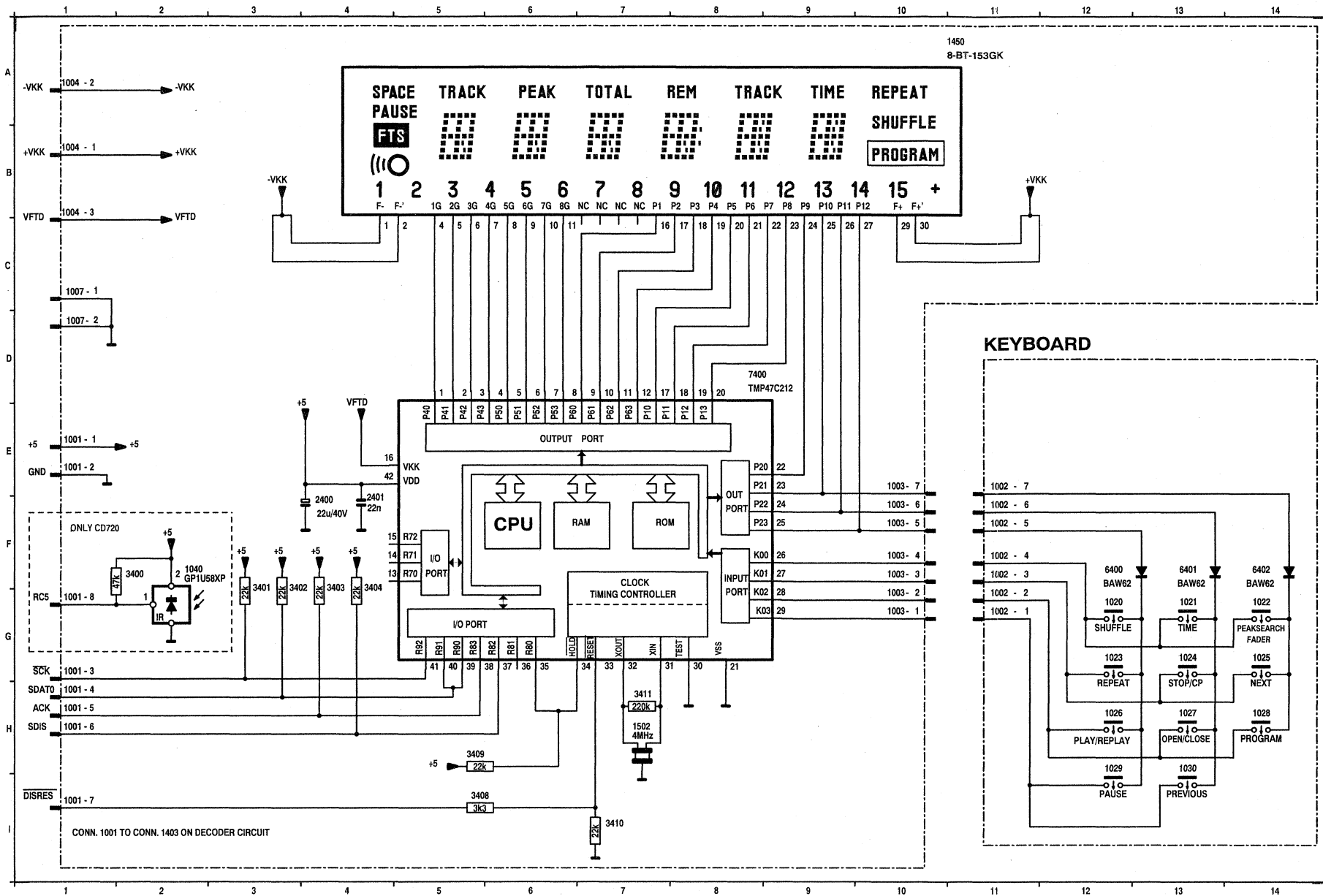

1001 E 1  
1001 E 1  
1001 G 1  
1001 H 1  
1001 H 1  
1001 H 1  
1001 I 1  
1001 I 1  
1001 G 1  
1002 G 11  
1002 G 11  
1002 F 11  
1002 F 11  
1002 F 11  
1002 F 11  
1002 E 11  
1003 G 10  
1003 F 10  
1003 F 10  
1003 F 10  
1003 F 10  
1004 B 1  
1004 A 1  
1004 B 1  
1007 C 1  
1007 D 1  
1020 G 12  
1021 G 13  
1022 G 14  
1023 G 12  
1024 G 13  
1025 G 14  
1026 H 12  
1027 H 13  
1028 H 14  
1029 H 12  
1030 H 13  
1040 F 2  
1450 A 10  
1502 H 7  
2400 F 4  
2401 F 4  
3400 F 2  
3401 G 3  
3402 G 3  
3403 G 4  
3404 G 4  
3408 I 5  
3409 H 5  
3410 I 7  
3411 H 7  
6400 F 12  
6401 F 13  
6402 F 14  
7400 D 8

3073\_0262\_d\_R

3073\_0262\_d\_B

DISPLAY PANEL

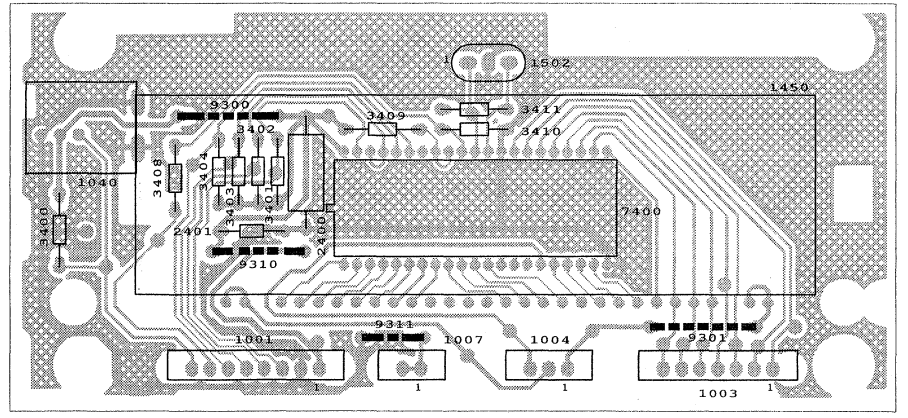

KEYBOARD PANEL

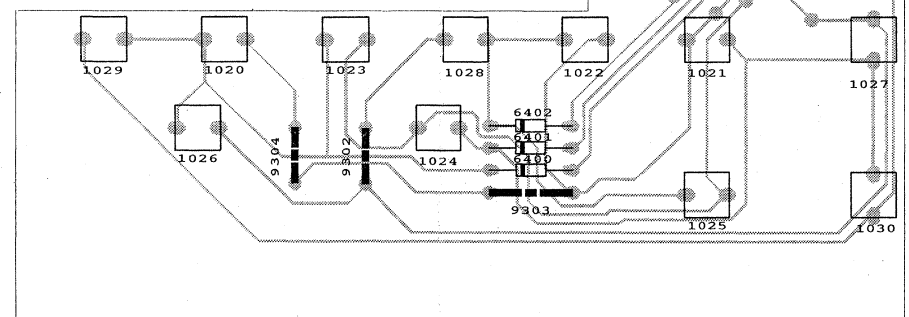



DETAIL I

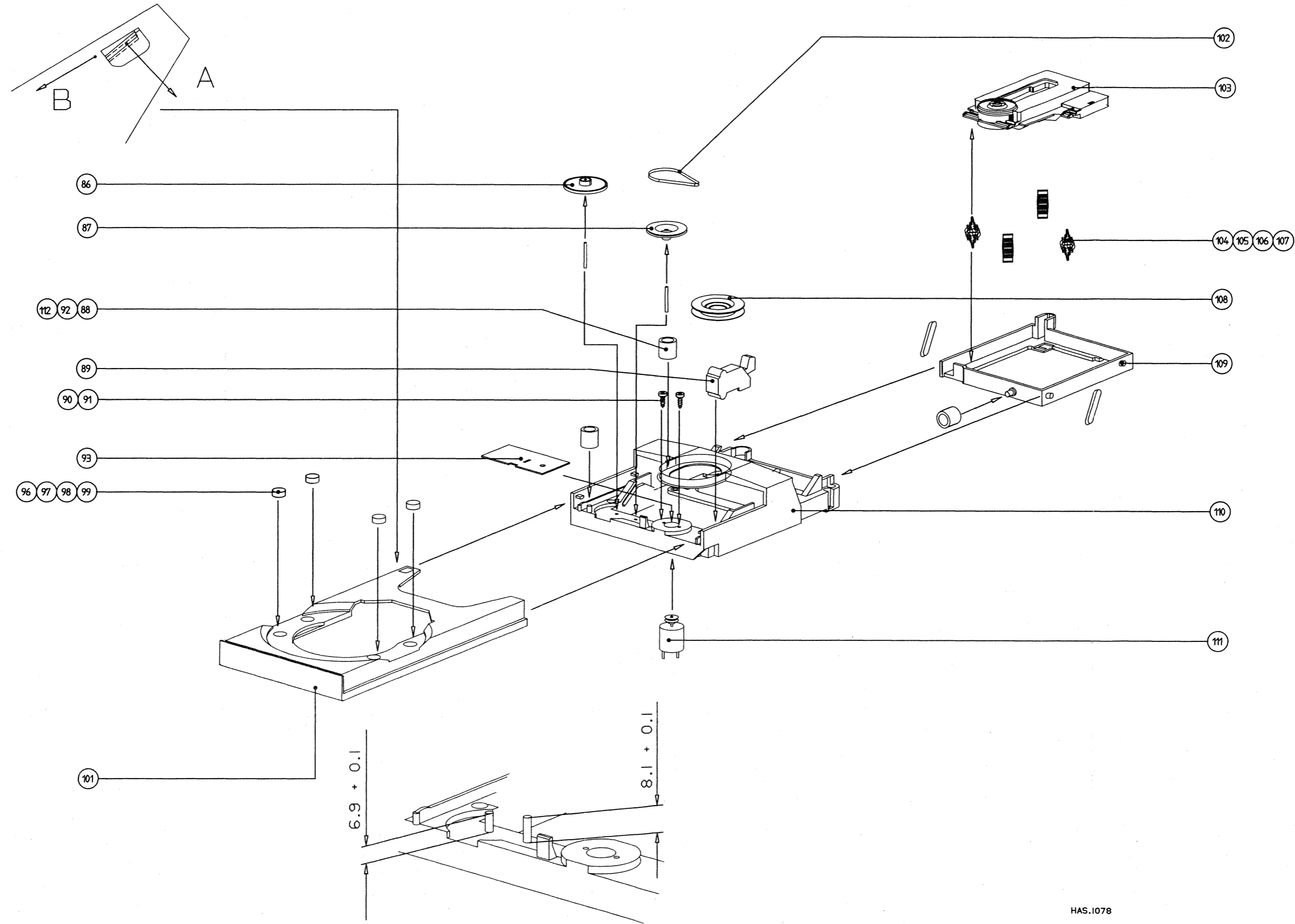

PARTS

- 86
- 87
- 88,92,
- 89
- 93
- 96,97,
- 101
- 102
- 103
- 104,10
- 108
- 109
- 110
- 110
- 111

Screw:

- 90,91

HAS.1078

**PARTS LIST LOADER**

86	4822 528 81464	DRIVE PINION
87	4822 528 81465	PULLEY
88,92,112	4822 325 60379	DAMPING GROMMET
89	4822 276 13222	SWITCH
93	4822 444 60816	COVER PLATE
96,97,98,99	4822 325 80511	ORNAMENTAL TULE
101	4822 444 50679	SLIDE
102	4822 358 31168	BELT
103	4822 691 30278	CDM12 MECHANISM
104,105,106,107	4822 325 50215	SUSPENSION
108	4822 402 61412	CLAMPER ASSY
109	4822 464 50895	SUBCHASSIS
110	4822 464 50678	CHASSIS (CD710/CD720)
110	4822 464 50896	CHASSIS (CD740/CD750/CD911/CD921)
111	4822 361 21492	MOTOR

**Screws**

90,91	M 2.2 x 4
-------	-----------

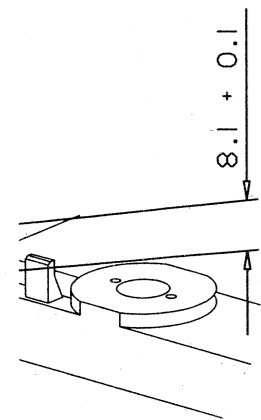
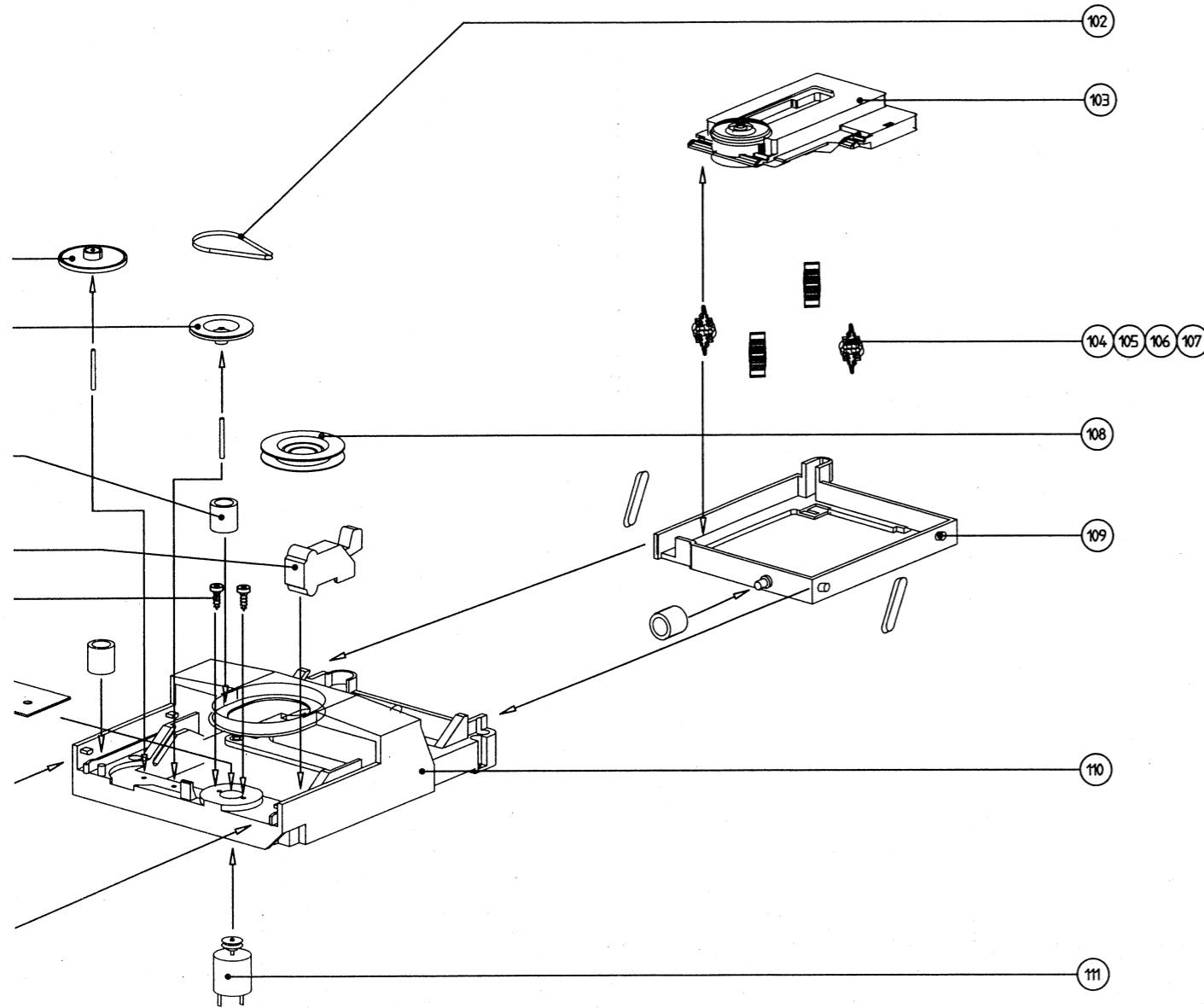

**MECHANICAL PARTS LIST**

1	4822 444 40717	FRONT CD710
1	4822 444 40723	FRONT CD720
8	4822 410 63093	BUTTON UNIT
9	4822 410 63092	POWER BUTTON
14	4822 459 10887	WORDMARK
15	4822 450 61895	WINDOW
53	4822 413 51468	VOLUME KNOB
54	4822 492 51374	SPRING
65	4822 444 40724	TRAY FRONT
151	4822 444 60976	COVER
251	4822 462 42081	FOOT
252	4822 462 42081	FOOT
253	4822 462 42081	FOOT
254	4822 462 42081	FOOT
255	4822 462 40683	TABLE PROTECTOR
256	4822 462 40683	TABLE PROTECTOR
257	4822 462 40683	TABLE PROTECTOR
258	4822 462 40683	TABLE PROTECTOR
283	4822 532 60948	BUSHING
284	4822 532 60948	BUSHING
308	4822 321 62381	AUDIO CORD
340	4822 736 21988	IFU MULTILANGUAGE
340	4822 736 22022	IFU /01B OVERSEA
365	4822 218 10537	REM.CONTROL RD6051

Not mentioned parts are only available during production period on special request.

**Screws**

Taptite	M3x6:	171,172,173,174
		175,176,177
		205
		210
		220,221
		291,292

Plastite	M3x8:	200,201,202
		M3x10: 39,40,41
		M3x12: 22,23,24,25

Taptite	M3x10:	203
		211

**EXPLODED VIEW**

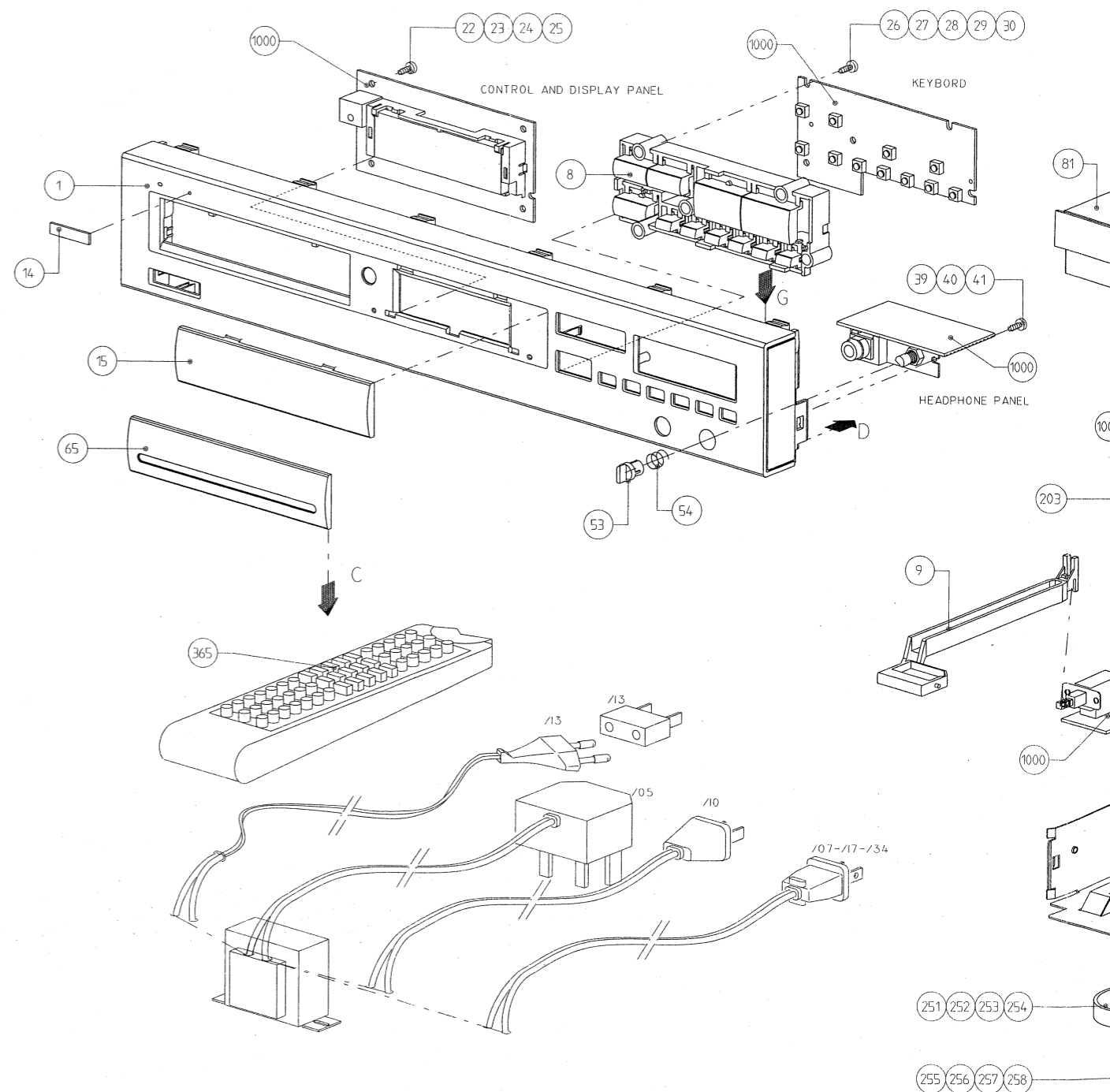

\* ONLY /01-VERSION

EXPLODED VIEW

33

33

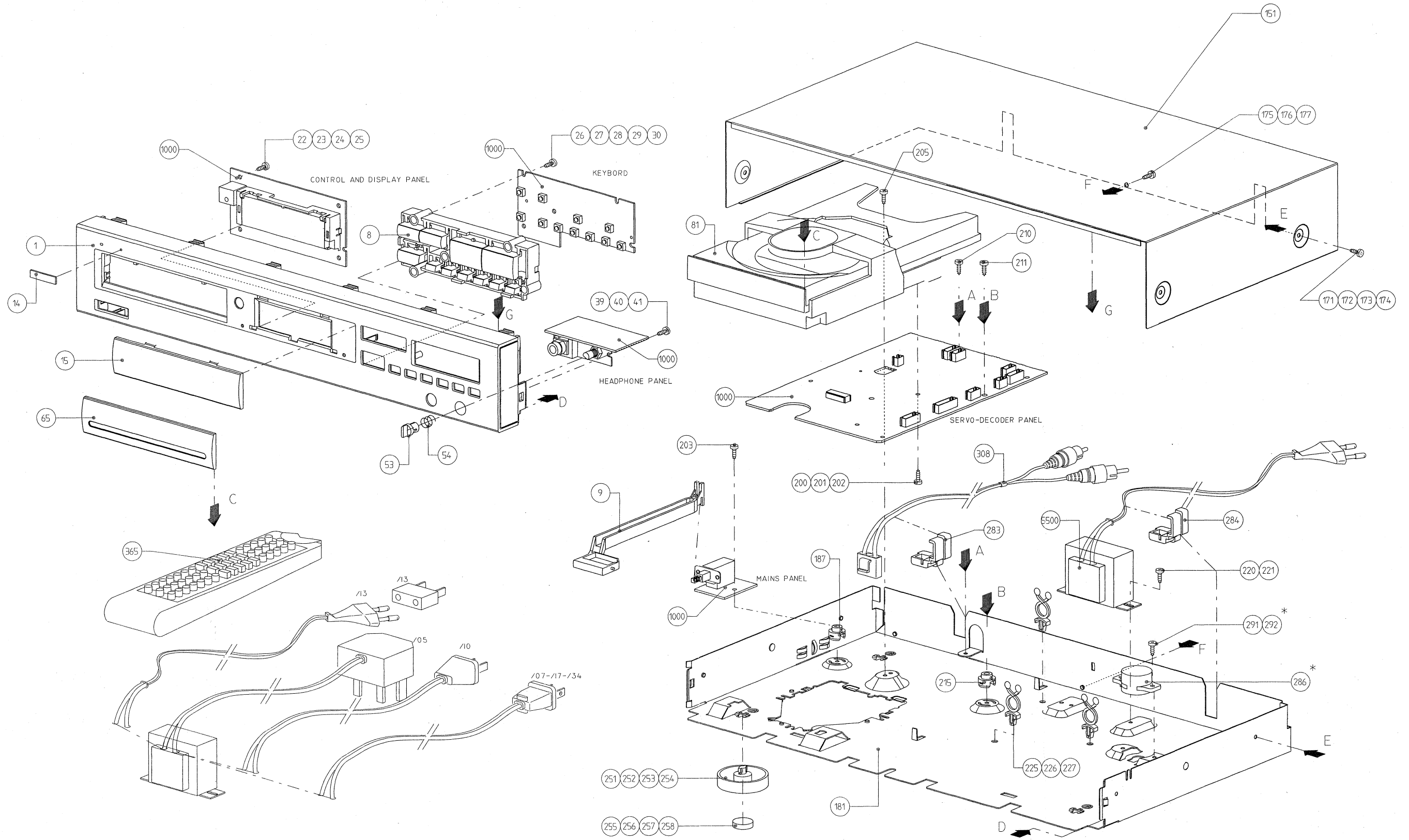

request.

\* ONLY /01-VERSION

HAS.CD720.00B

ELECTRICAL PARTS LIST

MISCELLANEOUS		
1000	4822 256 92151	DISPLAY HOLDER
1020	4822 242 73557	RESONATOR 8.46MHz
1021	4822 276 13114	TACT SWITCH
1022	4822 276 13114	TACT SWITCH
1023	4822 276 13114	TACT SWITCH
1024	4822 276 13114	TACT SWITCH
1025	4822 276 13114	TACT SWITCH
1026	4822 276 13114	TACT SWITCH
1027	4822 276 13114	TACT SWITCH
1028	4822 276 13114	TACT SWITCH
1029	4822 276 13114	TACT SWITCH
1030	4822 276 13114	TACT SWITCH
1040	4822 214 52009	IR RECEIVER GP1U58XP
1050	5322 242 73686	RESONATOR 12MHz
1101	4822 242 80997	RESONATOR 16.93MHz
1371	4822 267 31453	HEADPHONE SOCKET
1450	4822 130 91329	DISPLAY 8-BT-1536k
1502	4822 242 72527	RESONATOR 4MHz
1510 ▲	4822 071 51002	FUSE RADIAL T 1A
1511 ▲	4822 071 51002	FUSE RADIAL T 1A
1530 ▲	4822 276 13489	MAINS SWITCH

CAPACITORS		
2000	4822 122 10466	220pF 10% 50V
2001	4822 122 10466	220pF 10% 50V
2002	4822 122 10466	220pF 10% 50V
2003	4822 122 10466	220pF 10% 50V
2004	4822 122 10466	220pF 10% 50V
2005	4822 122 10466	220pF 10% 50V
2006	4822 126 12878	1,5nF 10% 16V
2007	4822 122 10459	560pF 10% 50V
2008	5322 124 21643	22µF 20% 40V
2009	4822 126 11585	22nF +80-20% 25V
2010	4822 126 11585	22nF +80-20% 25V
2011	5322 124 21643	22µF 20% 40V
2012	4822 126 11585	22nF +80-20% 25V
2013	5322 124 21643	22µF 20% 40V
2014	4822 126 12785	47nF TUB 50V
2025	5322 124 21643	22µF 20% 40V
2040	4822 126 10053	180pF 10%Y5P
2041	4822 126 10053	180pF 10%Y5P
2042	4822 126 12787	330pF 10% 50V
2043	4822 122 33848	47pF 5%SL 50V
2044	4822 122 33848	47pF 5%SL 50V
2045	4822 122 33195	100pF 10% 50V
2046	4822 126 12573	18pF 5% 50V
2047	5322 124 21643	22µF 20% 40V
2048	4822 126 12787	330pF 10% 50V

2049	4822 126 10053	180pF 10%Y5P
2050	4822 126 12787	330pF 10% 50V
2051	4822 126 11585	22nF +80-20% 25V
2052	5322 124 21643	22µF 20% 40V
2060	4822 126 12882	100nF +80-20% 50V
2062	4822 126 12882	100nF +80-20% 50V
2063	5322 121 42489	33nF 5% 250V
2064	4822 126 12882	100nF +80-20% 50V
2066	4822 126 12339	2,2nF 10% Y5Ω
2067	4822 126 12882	100nF +80-20% 50V
2068	4822 126 12148	2,7nF 10%
2069	4822 126 10053	180pF 10%Y5P
2071	4822 126 12882	100nF +80-20% 50V
2072	4822 126 12882	100nF +80-20% 50V
2074	4822 126 12882	100nF +80-20% 50V
2075	4822 126 13151	3,9nF 10%Y516V
2076	4822 126 10053	180pF 10%Y5P
2100	4822 126 12339	2,2nF 10% Y5Ω
2101	4822 122 33848	47pF 5%SL 50V
2102	4822 126 11585	22nF +80-20% 25V
2103	5322 121 42386	100nF 5% 63V
2105	4822 122 33195	100pF 10% 50V
2109	4822 122 33191	22pF 5% 50V
2110	5322 124 21643	22µF 20% 40V
2111	4822 126 12882	100nF +80-20% 50V
2115	4822 126 11585	22nF +80-20% 25V
2116	5322 124 21643	22µF 20% 40V
2118	4822 122 33848	47pF 5%SL 50V
2140	4822 126 12785	47nF TUB 50V
2141	4822 126 12882	100nF +80-20% 50V
2142	4822 122 33848	47pF 5%SL 50V
2280	4822 124 40433	47µF 20% 25V
2281	4822 126 12882	100nF +80-20% 50V
2300	4822 124 40433	47µF 20% 25V
2301	4822 124 40433	47µF 20% 25V
2302	4822 126 11585	22nF +80-20% 25V
2303	4822 124 40433	47µF 20% 25V
2304	4822 122 10466	220pF 10% 50V
2305	4822 122 33849	150pF 10%Y5P 50V
2306	4822 124 40246	4,7µF 20% 63V
2307	4822 122 10466	220pF 10% 50V
2308	4822 122 33849	150pF 10%Y5P 50V
2309	4822 124 40246	4,7µF 20% 63V
2310	4822 126 12882	100nF +80-20% 50V
2370	4822 126 11585	22nF +80-20% 25V
2371	4822 122 33197	1nF 10% 50V
2372	4822 122 33197	1nF 10% 50V
2373	4822 126 11585	22nF +80-20% 25V
2400	5322 124 21643	22µF 20% 40V
2401	4822 126 11585	22nF +80-20% 25V
2505	4822 122 33197	1nF 10% 50V
2514	4822 122 33197	1nF 10% 50V
2533	4822 126 11585	22nF +80-20% 25V
2534	4822 126 11585	22nF +80-20% 25V

2535	4822 126 12882	100nF +80-20% 50V
2536	4822 124 80294	3300µF 20% 16V
2537	4822 126 11585	22nF +80-20% 25V
2538	4822 124 80148	2200µF 20% 16V
2539	4822 126 11585	22nF +80-20% 25V
2540	5322 124 22094	220µF 20% 50V
2541	4822 126 12882	100nF +80-20% 50V
2542	4822 124 40184	1000µF 20% 10V
2560	4822 124 40849	330µF 20% 16V
2600	4822 126 12882	100nF +80-20% 50V
2601	4822 126 11585	22nF +80-20% 25V
2602	4822 126 11585	22nF +80-20% 25V
2701	4822 126 11585	22nF +80-20% 25V
2703	4822 126 11585	22nF +80-20% 25V

RESISTORS		
3000	4822 116 52233	10k 5% 0,5W
3001	4822 116 52233	10k 5% 0,5W
3002	4822 116 52233	10k 5% 0,5W
3003	4822 116 52233	10k 5% 0,5W
3004	4822 116 52233	10k 5% 0,5W
3005	4822 116 52233	10k 5% 0,5W
3006	4822 050 11002	1k 1% 0,4W
3007	4822 050 11002	1k 1% 0,4W
3010	4822 116 52235	1M 5% 0,5W
3011	4822 116 52233	10k 5% 0,5W
3012	4822 116 52219	330Ω 5% 0,5W
3013	4822 050 11002	1k 1% 0,4W
3014	4822 116 52233	10k 5% 0,5W
3015	4822 116 52219	330Ω 5% 0,5W
3020	4822 050 11002	1k 1% 0,4W
3021	4822 116 52233	10k 5% 0,5W
3022 ▲	4822 052 10478	4Ω7 5% 0,33W
3040	4822 116 52239	120k 5% 0,5W
3041	4822 116 52239	120k 5% 0,5W
3042	4822 116 52291	56k 5% 0,5W
3043	4822 050 11002	1k 1% 0,4W
3044	4822 116 52222	390Ω 5% 0,5W
3045	4822 116 52175	100Ω 5% 0,5W
3046	4822 116 52249	1k8 5% 0,5W
3047	4822 116 52276	3k9 5% 0,5W
3048	4822 116 52175	100Ω 5% 0,5W
3049	4822 116 52249	1k8 5% 0,5W
3050	4822 116 52223	430Ω 5% 0,5W
3051	4822 116 52223	430Ω 5% 0,5W
3052	4822 050 11002	1k 1% 0,4W
3053	4822 116 52267	30k 5% 0,5W
3054	4822 116 52272	330k 5% 0,5W
3055	4822 116 52175	100Ω 5% 0,5W
3056	4822 050 11002	1k 1% 0,4W
3057	4822 116 52277	39k 5% 0,5W

3058	4822 116 52175	100Ω 5% 0,5W
3059	4822 116 52284	47k 5% 0,5W
3060	4822 116 52233	10k 5% 0,5W
3062 ▲	4822 052 10229	22Ω 5% 0,33W
3064	4822 116 52296	6k8 5% 0,5W
3065	4822 050 27502	7k5 1% 0,6W
3066	4822 050 21503	15k 1% 0,6W
3067	4822 116 52244	15k 5% 0,5W
3068 ▲	4822 052 10229	22Ω 5% 0,33W
3069	4822 116 52233	10k 5% 0,5W
3070	4822 116 52244	15k 5% 0,5W
3071	4822 116 52296	6k8 5% 0,5W
3072	4822 116 52233	10k 5% 0,5W
3073	4822 116 52244	15k 5% 0,5W
3074 ▲	4822 052 10229	22Ω 5% 0,33W
3075	4822 116 52233	10k 5% 0,5W
3076	4822 116 52283	4k7 5% 0,5W
3077	4822 116 52296	6k8 5% 0,5W
3078	4822 116 52244	15k 5% 0,5W
3079	4822 116 52244	15k 5% 0,5W
3100	4822 116 52256	2k2 5% 0,5W
3101	4822 116 52257	22k 5% 0,5W
3107	4822 116 52219	330Ω 5% 0,5W
3108	4822 116 52215	220Ω 5% 0,5W
3109	4822 116 52215	220Ω 5% 0,5W
3110	4822 116 52215	220Ω 5% 0,5W
3111	4822 116 52215	220Ω 5% 0,5W
3112	4822 116 52175	100Ω 5% 0,5W
3113 ▲	4822 052 10338	3Ω3 5% 0,33W
3114	4822 116 52235	1M 5% 0,5W
3115 ▲	4822 052 10338	3Ω3 5% 0,33W
3116	4822 116 52175	100Ω 5% 0,5W
3117	4822 116 52219	330Ω 5% 0,5W
3140	4822 116 52271	33k 5% 0,5W
3141	4822 116 52271	33k 5% 0,5W
3142	4822 116 52271	33k 5% 0,5W
3143	4822 116 52234	100k 5% 0,5W
3144	4822 116 52234	100k 5% 0,5W
3145 ▲	4822 052 10229	22Ω 5% 0,33W
3146	4822 116 52175	100Ω 5% 0,5W
3280 ▲	4822 052 10338	3Ω3 5% 0,33W
3300	4822 116 52251	18k 5% 0,5W
3301	4822 116 52244	15k 5% 0,5W
3302 ▲	4822 052 10108	1Ω 5% 0,33W
3303 ▲	4822 052 10108	1Ω 5% 0,33W
3304	4822 116 52276	3k9 5% 0,5W
3305	4822 116 52276	3k9 5% 0,5W
3306	4822 116 52257	22k 5% 0,5W
3307	4822 116 52257	22k 5% 0,5W
3360	4822 050 11002	1k 1% 0,4W
3361	4822 116 52256	2k2 5% 0,5W
3362	4822 116 52256	2k2 5% 0,5W
3363	4822 050 11002	1k 1% 0,4W
3364	4822 050 11002	1k 1% 0,4W

3365  
3366  
3367  
3368  
3369  
3370  
3371  
3372  
3373  
3374  
3375  
3376  
3377  
3386  
3400  
3401  
3402  
3403  
3404  
3408  
3409  
3410  
3411  
3500  
3501  
3502  
3503  
3540  
3541  
3542  
3543  
3544  
3545  
3560  
3562  
3563  
3601  
3602  
3603  
3604  
3606  
3607  
3700  
3701  
3703  
3706  
3707  
3708  
3709  
3710  
3712  
3713  
3715





2535	4822 126 12882	100nF +80-20% 50V	3058	4822 116 52175	100Ω 5% 0,5W
2536	4822 124 80294	3300μF 20% 16V	3059	4822 116 52284	47k 5% 0,5W
2537	4822 126 11585	22nF +80-20% 25V	3060	4822 116 52233	10k 5% 0,5W
2538	4822 124 80148	2200μF 20% 16V	3062 ▲	4822 052 10229	22Ω 5% 0,33W
2539	4822 126 11585	22nF +80-20% 25V	3064	4822 116 52296	6k8 5% 0,5W
2540	5322 124 22094	220μF 20% 50V	3065	4822 050 27502	7k5 1% 0,6W
2541	4822 126 12882	100nF +80-20% 50V	3066	4822 050 21503	15k 1% 0,6W
2542	4822 124 40184	1000μF 20% 10V	3067	4822 116 52244	15k 5% 0,5W
2560	4822 124 40849	330μF 20% 16V	3068 ▲	4822 052 10229	22Ω 5% 0,33W
2600	4822 126 12882	100nF +80-20% 50V	3069	4822 116 52233	10k 5% 0,5W
2601	4822 126 11585	22nF +80-20% 25V	3070	4822 116 52244	15k 5% 0,5W
2602	4822 126 11585	22nF +80-20% 25V	3071	4822 116 52296	6k8 5% 0,5W
2701	4822 126 11585	22nF +80-20% 25V	3072	4822 116 52233	10k 5% 0,5W
2703	4822 126 11585	22nF +80-20% 25V	3073	4822 116 52244	15k 5% 0,5W
3000	4822 116 52233	10k 5% 0,5W	3074 ▲	4822 052 10229	22Ω 5% 0,33W
3001	4822 116 52233	10k 5% 0,5W	3075	4822 116 52233	10k 5% 0,5W
3002	4822 116 52233	10k 5% 0,5W	3076	4822 116 52283	4k7 5% 0,5W
3003	4822 116 52233	10k 5% 0,5W	3077	4822 116 52296	6k8 5% 0,5W
3004	4822 116 52233	10k 5% 0,5W	3078	4822 116 52244	15k 5% 0,5W
3005	4822 116 52233	10k 5% 0,5W	3079	4822 116 52244	15k 5% 0,5W
3006	4822 050 11002	1k 1% 0,4W	3100	4822 116 52256	2k2 5% 0,5W
3007	4822 050 11002	1k 1% 0,4W	3101	4822 116 52257	22k 5% 0,5W
3010	4822 116 52235	1M 5% 0,5W	3107	4822 116 52219	330Ω 5% 0,5W
3011	4822 116 52233	10k 5% 0,5W	3108	4822 116 52215	220Ω 5% 0,5W
3012	4822 116 52219	330Ω 5% 0,5W	3109	4822 116 52215	220Ω 5% 0,5W
3013	4822 050 11002	1k 1% 0,4W	3110	4822 116 52215	220Ω 5% 0,5W
3014	4822 116 52233	10k 5% 0,5W	3111	4822 116 52215	220Ω 5% 0,5W
3015	4822 116 52219	330Ω 5% 0,5W	3112	4822 116 52175	100Ω 5% 0,5W
3020	4822 050 11002	1k 1% 0,4W	3113 ▲	4822 052 10338	3Ω3 5% 0,33W
3021	4822 116 52233	10k 5% 0,5W	3114	4822 116 52235	1M 5% 0,5W
3022 ▲	4822 052 10478	4Ω7 5% 0,33W	3115 ▲	4822 052 10338	3Ω3 5% 0,33W
3040	4822 116 52239	120k 5% 0,5W	3116	4822 116 52175	100Ω 5% 0,5W
3041	4822 116 52239	120k 5% 0,5W	3117	4822 116 52219	330Ω 5% 0,5W
3042	4822 116 52291	56k 5% 0,5W	3140	4822 116 52271	33k 5% 0,5W
3043	4822 050 11002	1k 1% 0,4W	3141	4822 116 52271	33k 5% 0,5W
3044	4822 116 52222	390Ω 5% 0,5W	3142	4822 116 52271	33k 5% 0,5W
3045	4822 116 52175	100Ω 5% 0,5W	3143	4822 116 52234	100k 5% 0,5W
3046	4822 116 52249	1k8 5% 0,5W	3144	4822 116 52234	100k 5% 0,5W
3047	4822 116 52276	3k9 5% 0,5W	3145 ▲	4822 052 10229	22Ω 5% 0,33W
3048	4822 116 52175	100Ω 5% 0,5W	3146	4822 116 52175	100Ω 5% 0,5W
3049	4822 116 52249	1k8 5% 0,5W	3280 ▲	4822 052 10338	3Ω3 5% 0,33W
3050	4822 116 52223	430Ω 5% 0,5W	3300	4822 116 52251	18k 5% 0,5W
3051	4822 116 52223	430Ω 5% 0,5W	3301	4822 116 52244	15k 5% 0,5W
3052	4822 050 11002	1k 1% 0,4W	3302 ▲	4822 052 10108	1Ω 5% 0,33W
3053	4822 116 52267	30k 5% 0,5W	3303 ▲	4822 052 10108	1Ω 5% 0,33W
3054	4822 116 52272	330k 5% 0,5W	3304	4822 116 52276	3k9 5% 0,5W
3055	4822 116 52175	100Ω 5% 0,5W	3305	4822 116 52276	3k9 5% 0,5W
3056	4822 050 11002	1k 1% 0,4W	3306	4822 116 52257	22k 5% 0,5W
3057	4822 116 52277	39k 5% 0,5W	3307	4822 116 52257	22k 5% 0,5W
3308	4822 116 52256	2k2 5% 0,5W	3360	4822 050 11002	1k 1% 0,4W
3309	4822 116 52256	2k2 5% 0,5W	3361	4822 116 52256	2k2 5% 0,5W
3362	4822 116 52256	2k2 5% 0,5W	3362	4822 116 52256	2k2 5% 0,5W
3363	4822 050 11002	1k 1% 0,4W	3363	4822 050 11002	1k 1% 0,4W
3364	4822 050 11002	1k 1% 0,4W	3364	4822 050 11002	1k 1% 0,4W

## RESISTORS

3365	4822 116 52256	2k2 5% 0,5W	3716	4822 050 11002	1k 1% 0,4W
3366	4822 050 11002	1k 1% 0,4W	3717	4822 050 11002	1k 1% 0,4W
3367	4822 116 52256	2k2 5% 0,5W	3718	4822 050 11002	1k 1% 0,4W
3368	4822 116 52258	220k 5% 0,5W	3719	4822 050 11002	1k 1% 0,4W
3369	4822 116 52258	220k 5% 0,5W	3720	4822 050 11002	1k 1% 0,4W
3370	4822 116 52284	47k 5% 0,5W	3723	4822 116 52257	22k 5% 0,5W
3371	4822 116 52284	47k 5% 0,5W	<b>COILS</b>		
3372	4822 116 52233	10k 5% 0,5W	5010	4822 157 62552	2,2μH
3373	4822 116 52244	15k 5% 0,5W	5300	4822 157 71086	COIL 4,7μH
3374	4822 116 52244	15k 5% 0,5W	5301	4822 157 71086	COIL 4,7μH
3375	4822 116 52206	120Ω 5% 0,5W			
3376	4822 101 21199	10kX2 20% 0,025W			
3377	4822 116 52233	10k 5% 0,5W			
3386	4822 116 52206	120Ω 5% 0,5W			
3400	4822 116 52284	47k 5% 0,5W			
3401	4822 116 52257	22k 5% 0,5W			
3402	4822 116 52257	22k 5% 0,5W			
3403	4822 116 52257	22k 5% 0,5W			
3404	4822 116 52257	22k 5% 0,5W			
3408	4822 116 52269	3k3 5% 0,5W			
3409	4822 116 52257	22k 5% 0,5W			
3410	4822 116 52257	22k 5% 0,5W			
3411	4822 116 52258	220k 5% 0,5W			
3500	4822 116 52226	560Ω 5% 0,5W			
3501	4822 050 11002	1k 1% 0,4W			
3502	4822 116 52257	22k 5% 0,5W			
3503	4822 116 52257	22k 5% 0,5W			
3540	4822 116 52284	47k 5% 0,5W			
3541	4822 116 52231	820Ω 5% 0,5W			
3542	4822 116 52263	2k7 5% 0,5W			
3543	4822 116 52283	4k7 5% 0,5W			
3544	4822 116 52257	22k 5% 0,5W			
3545 ▲	4822 052 10478	4Ω7 5% 0,33W			
3560	4822 050 11002	1k 1% 0,4W			
3562	4822 116 52283	4k7 5% 0,5W			
3563	4822 116 52283	4k7 5% 0,5W			
3601	4822 116 52238	12k 5% 0,5W			
3602	4822 116 52238	12k 5% 0,5W			
3603 ▲	4822 052 10229	22Ω 5% 0,33W			
3604	4822 116 52303	8k2 5% 0,5W			
3606	4822 116 52238	12k 5% 0,5W			
3607	4822 116 52238	12k 5% 0,5W			
3700	4822 116 52258	220k 5% 0,5W			
3701	4822 116 52257	22k 5% 0,5W			
3703	4822 116 52257	22k 5% 0,5W			
3706	4822 116 52257	22k 5% 0,5W			
3707	4822 116 52257	22k 5% 0,5W			
3708	4822 116 52257	22k 5% 0,5W			
3709	4822 116 52257	22k 5% 0,5W			
3710	4822 116 52257	22k 5% 0,5W			
3712	4822 116 52257	22k 5% 0,5W			
3713	4822 116 52257	22k 5% 0,5W			
3715	4822 116 52233	10k 5% 0,5W			

DIODES			MAINS VOLTAGE		
6360	4822 130 30621	1N4148	5500 ▲	4822 146 31337	MAINS TRANSFO /00B
6361	4822 130 30621	1N4148	5500 ▲	4822 146 31339	MAINS TRANSFO /05B
6400	4822 130 30613	BAW62	5500 ▲	4822 146 31338	MAINS TRANSFO /01B
6401	4822 130 30613	BAW62			
6402	4822 130 30613	BAW62			
6500	4822 130 31981	BZX79-C3V9			
6535	5322 130 30684	1N4002GP			
6536	5322 130 30684	1N4002GP			
6537	5322 130 30684	1N4002GP			
6538	5322 130 30684	1N4002GP			
6540	5322 130 30684	1N4002GP			
6541	4822 130 34278	BZX79-C6V8			
6542	4822 130 30621	1N4148			
6543	5322 130 30684	1N4002GP			
6544	4822 130 30621	1N4148			
6560	5322 130 30684	1N4002GP			
6561	5322 130 30684	1N4002GP			
6562	4822 130 31981	BZX79-C3V9			
TRANSISTORS & IC'S					
7000	4822 209 31064	TDA1301T/N1			
7040	4822 130 40902	BF240			
7041	4822 130 40937	BC548B			
7042	4822 130 44197	BC558B			
7043	4822 130 40937	BC548B			
7044	4822 130 40937	BC548B			
7060	4822 209 72587	TCA0372			
7061	4822 209 72587	TCA0372			
7100	4822 209 33166	SAA7345GP/M2A			
7280	4822 209 33164	TDA1545AT/N2			
7300	4822 209 83274	NJM4560D			
7360	4822 130 44121	BC338			
7361	4822 130 44121	BC338			
7362	4822 130 44121	BC338			
7363	4822 130 44121	BC338			
7364	4822 130 44197	BC558B			
7365	4822 130 44197	BC558B			
7370	4822 209 82362	NJM4556D			
7400	4822 209 30249	TMP47C212AN			
7500	4822 130 44197	BC558B			
7535 ▲	4822 209 80891	MC7805CT			
7540	5322 209 62115	MC79L15AC			
7541	4822 130 40937	BC548B			
7542	4822 130 44121	BC338			
7543	4822 130 44197	BC558B			
7600	4822 209 72587	TCA0372			
7650	4822 130 44197	BC558B			
7700	4822 209 33249	MC68HC11ER20/P159-07			



# SI

## Wichtig für die Werkstatt!

Sachgebiet: AC 52 CD

Nummer: 52139

Datum: 30.09.1994

### Service Information

Betrifft: CD-Spieler CD710/CD720  
Service-Hinweise

Verteiler:

INTERN und EXTERN

#### 1. Fokusfehler

Durch das Zusammenwirken von Eigenschaften des Laufwerkes CDM12.1 und des Servo-IC TDA1301 kann es bei einem ganz besonderen Plattenfehler ("white dropout" mit einer Dauer von ca. 100µs) zum Aussetzen der Fokussierung kommen, obwohl CD's mit diesem Fehler noch dem Standard entsprechen.

Zur Verbesserung der Fokusfunktion in solchen Fällen wird den beiden Photodioden D2 und D3 ein kleiner Offset-Strom zugeführt. Dazu sind am Servo-IC TDA1301 je ein Widerstand 3M9 von Pin 4 (VRH) nach Pin 5 und nach Pin 6 zugefügt worden.

Widerstand 3M9

4822 050 23905

#### 2. Resetfunktion

Zur Verbesserung der Resetfunktion bei höheren Umgebungstemperaturen ist ab Woche 9425 der Resetpegel von 4V auf 4.5V erhöht worden durch Ändern des Widerstandes 3500 (Service Manual S.27; Decoderschaltbild).

3500 (560E) geändert in 150E

4822 116 52211

#### 3. Decoder-IC

In Geräten aus Fertigung ab Woche 9420 ist das Decoder-IC 7100 (SAA7345GP/M2A) ersetzt worden durch SAA7345GP/M5.

Die beiden Ausführungen sind **n i c h t k o m p a t i b e l !**

Mit der Einführung der .../M5-Version ist die Oszillator-Beschaltung des Decoder-IC geändert worden:

- R3117 (330E) ersetzt durch Drahtbrücke
- C2112 hinzugefügt von Pin 13/7100 nach Masse  
C2112 22pF 4822 122 33191
- Resonator 1101 ersetzt durch eine andere Ausführung mit abweichender interner Kapazität  
1101 16.93MHz 4822 242 81865

Bei Ersatz des Decoder-IC 7100 ist auf die verwendete Ausführung zu achten; beide Versionen sind verfügbar:

7100 SAA7345GP/M2A 4822 209 33166  
7100 SAA7345GP/M5 4822 209 33339

4812 829 52139

Philips GmbH · Geschäftsbereich Service · Hamburg

Service  
Service  
Service

Soll eine IC-Version durch die andere ersetzt werden, dann muß die Oszillator-Beschaltung angepaßt werden (s. Abb.).

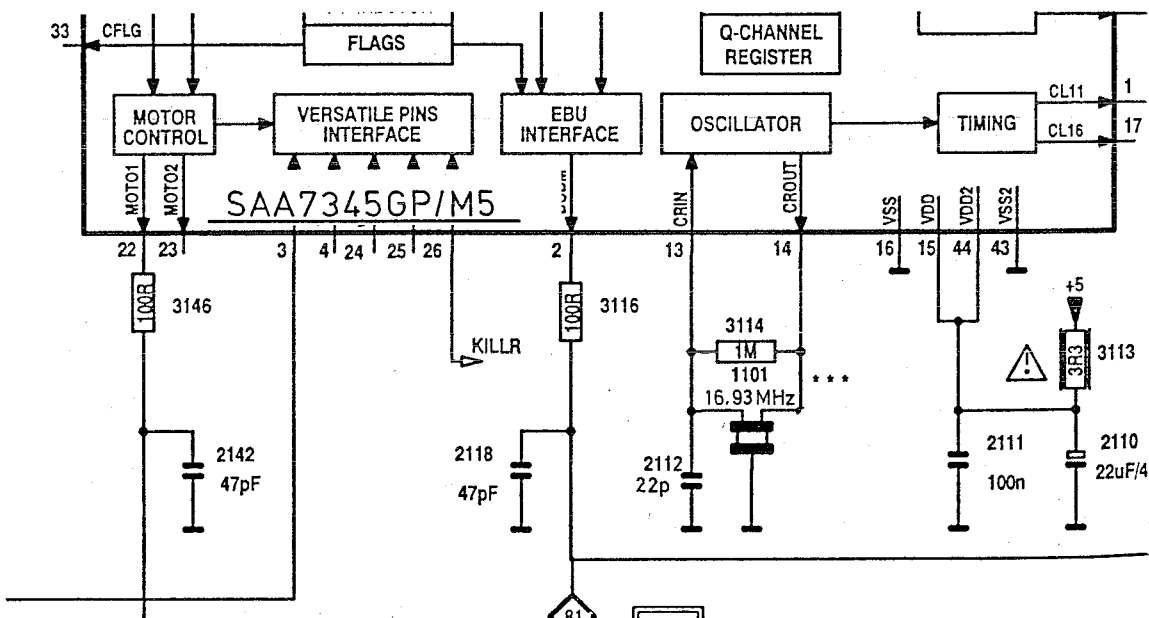
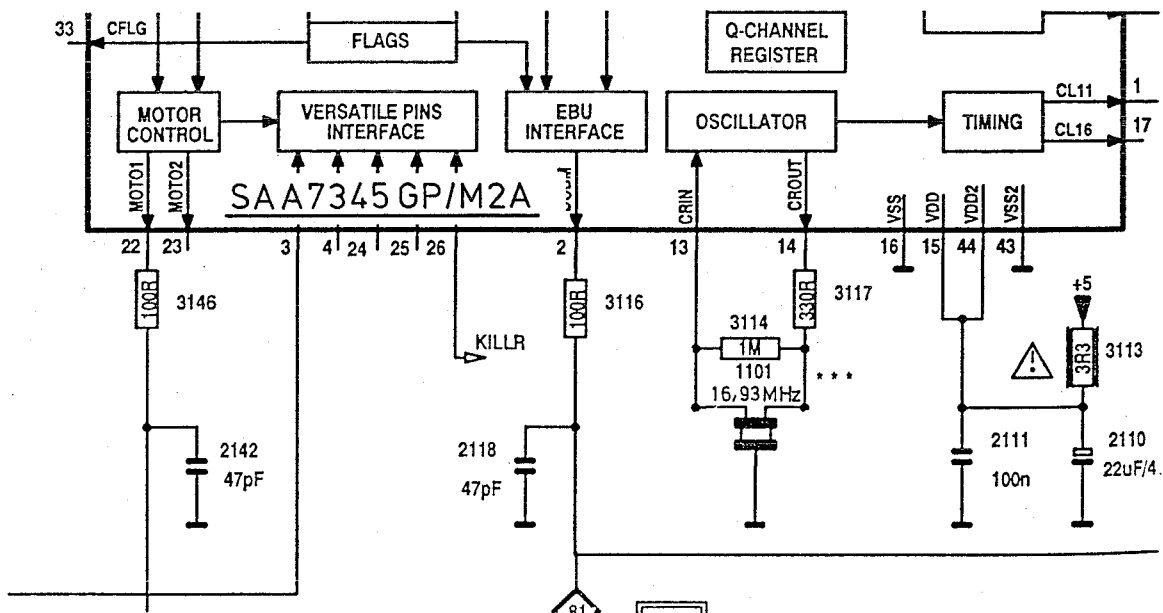

4. Netzteil

Von Beginn der Fertigung an ist als Diode 6540 (Service Manual, S.25) nicht der Typ 1N4002 sondern 1N4004 verwendet worden.

6540 1N4004

4822 130 83362

5. HF-Verstärker

Von Beginn der Fertigung an ist der Wert des Kondensators 2050 (Service Manual, S.26) nicht 330pF sondern 220pF.

2050 220pF

4822 122 10466

### 3.4. Functional description

#### 3.4.1. Front-end

##### Data slicer

The SAA7345 has an integrated slice level comparator which is clocked by the crystal frequency clock.

The slice level is controlled by an internal current source applied to an external capacitor under the control of the digital phase-locked loop(DPLL).

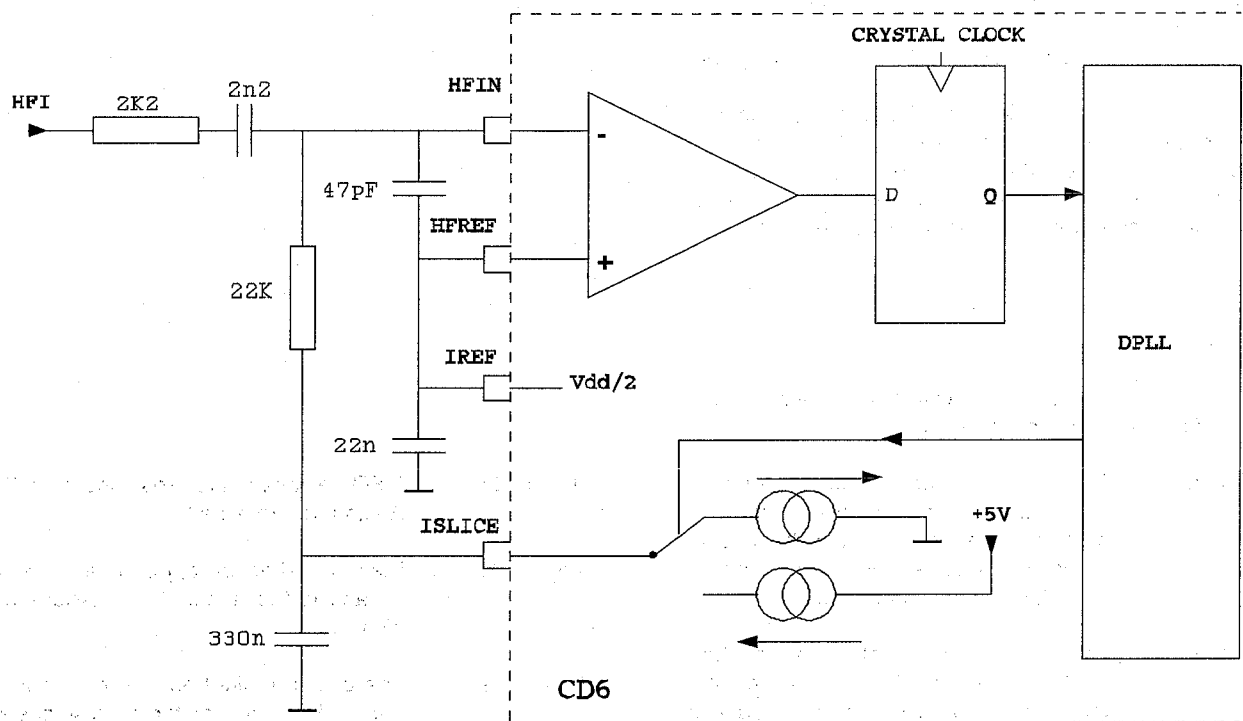

##### Digital PLL

Regeneration of the bit clock is achieved with an internal fully digital PLL. No external components are required and the bit clock is not output. The PLL has two micro-processor control registers(addresses 1000 and 1001) for bandwidth and equalization.

An offtrack input(OTD) is input via the V1 pin (pin3) of the versatile pins interface. When this flag is HIGH, the SAA7345 will assume that the servo is following on the wrong track, and will flag all incoming HF data as incorrect.

##### Error corrector

The error corrector carries out  $t=2, e=0$  error corrections on both C1(32 symbol) and C2(28 symbol) frames. Four symbols are used from each frame as parity symbols. The strategy  $t=2, e=0$  means that the error corrector can correct two erroneous symbols per frame and detect all erroneous frames.

The error corrector also contains a flag processor. Flags are assigned to symbols when the error corrector cannot ascertain if the symbols are definitely good. C1 generates output flags which are read (after de-interleaving) by C2, to help in the generation of C2 output flags.

The C2 output flags are used by the interpolator for concealment of uncorrectable errors. They are also output via the EBU signal(DOBM) and the MISC output with I<sup>2</sup>S for CD-ROM applications.

The flags output pin CFLG provides information on the state of all error correction and concealment flags. In comparison with CD4+, CD6 has a better error corrector. The error correction performance of CD6 depends on which crystal is used and on which speed is performed. The best performance is achieved with a 33.9 MHz crystal at single speed.

### 3.4.2. Turntable motor control

The turntable motor speed is controlled by a fully integrated digital servo. Address information from the internal + 8 frame FIFO and disc speed information are used to calculate the motor control output signals.

Several output modes are supported:

1. Pulse Density Modulation, 2-line(true complement output), 1MHz sample frequency.
2. PWM output, 2-line, 22.05 kHz modulation frequency.
3. PWM output, 4-line, 22.05 kHz modulation frequency.
4. CDV motor mode.

The modes are selected via the motor output configuration register.

In this application, the single-ended PDM mode is used.

In this mode, the motor output pin MOTO1 contains an accelerating as well as a braking action.

50% duty cycle corresponds with the motor not actuated, higher duty cycles mean acceleration, lower mean braking.

#### Operation modes

The motor servo has the following operation modes controlled by the motor mode register.

Start mode 1	Disc is accelerated by applying a positive voltage to the spindle motor. No decisions are involved and the PLL is reset. No disc speed information is available for the microprocessor.	Play mode	FIFO released after resetting to 50%. Audio mute released.
Start mode 2	The disc is accelerated as in Start mode 1, however the PLL will monitor the disc speed. When the disc reaches 75% of its nominal speed, the controller will switch to Jump mode.	Stop mode 1	Disc is braked by applying a negative voltage to the motor. No decisions are involved.
Jump mode	Motor servo enabled but FIFO kept rest at 50%. The audio is muted but it is possible to read the subcode.	Stop mode 2	The disc is braked as in Stop mode 1, but the PLL will monitor the disc speed. As soon as the disc reaches 12% of its nominal speed, the MOTSTOP status signal will go HIGH and switch servo to Off mode.
Jump mode 1	Similar to Jump mode but motor integrator is kept at zero. Used for long jumps.	Off mode	Motor is not steered.

### 3.4.3. Audio functions

#### De-emphasis and phase linearity

When de-emphasis is detected in the Q-channel subcode, the digital filter automatically includes a de-emphasis filter section.

When de-emphasis is not required, a phase compensation filter section controls the phase linearity of the digital oversampling filter to  $\leq \pm 1^\circ$  within the band 0 to 16 kHz.

#### Digital oversampling filter

The SAA7345 contains a 2-4 times oversampling IIR filter. This means that the impulse response of this filter is infinite.

The advantage of using an IIR filter is that it is easy and cheap to implement on a chip. The main disadvantage is that it is inherently not phase linear.

#### Concealment

A 1-sample linear interpolator becomes active if a single sample is flagged as erroneous but cannot be corrected. The erroneous sample is replaced by a level midway between the preceding and following samples. Left and right channels have independent interpolators.

If more than one consecutive uncorrectable sample is found, the last good sample is held. A 1-sample linear interpolation is then performed before the next good sample.

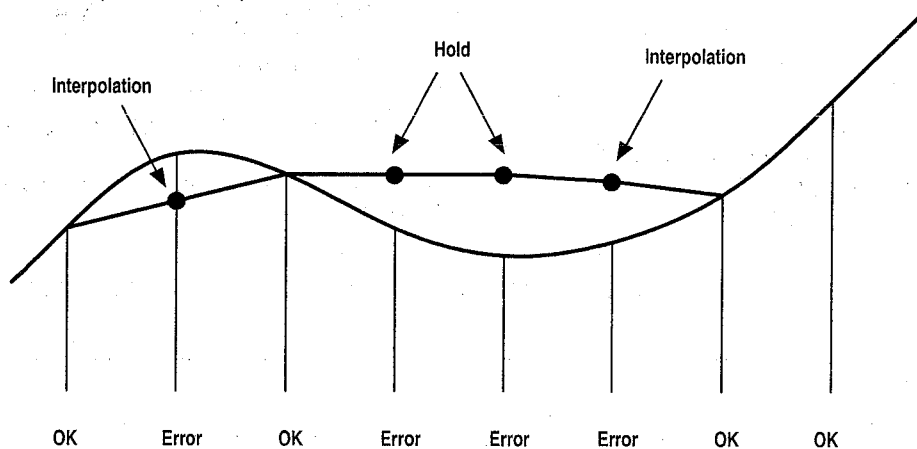

Concealment mechanism

#### Mute, Attenuation and Fade

A digital level controller is present on the SAA7345 which performs the functions of soft mute, attenuation and fade. All these functions are software programmable.

Soft mute is activated by sending the Mute command to the fade control register, attenuation (-12dB) is activated by sending the Attenuate command. Attenuation and mute are cancelled by sending the full scale command.

The audio output is determined by the value of the internal fade counter.

$$\text{Level} = \frac{\text{counter}}{128} \times \text{maximum level}$$

The counter is preset to 128 by the Full scale command if no oversampling is required.

The counter is preset to 120 (-0.5dB scaling) by the Full scale command if either 2 or 4 fs oversampling is programmed in the DAC output register.

The counter is preset to 32 by the Attenuate command.

The counter is preset to 0 by the Mute command.

To control the fade counter in a continuous way, the step-up and step-down commands are available. They will increment or decrement the counter by 1 for each register write operation.



**Serial data interface**

SAA7345 can be used in the CD-ROM mode, in fs (= no oversampling), in 2 fs or in 4fs (= 4 times oversampled) mode by programming the corresponding register.

Also the DAC output format can be programmed (Japanese 16 or 18 bit or Philips 16 bit). There are 10 possible DAC output formats :

MODE	SAMPLE FREQ.	BITS	SCLK Mhz	Fig.	DAC type	INTER-POLATIONS
1	Fs	16	2.1	A	CD-ROM	NO
2	Fs	16	2.1	A	Philips 16 bits	Yes
3	Fs	16	2.1	B	Japanese 16 bits	Yes
4	Fs	18	2.1	B	Japanese 18 bits	Yes
5	4Fs	16	8.5	B	Japanese 16 bits	Yes
6	4Fs	18	8.5	B	Japanese 18 bits	Yes
7	4Fs	16	8.5	A	Philips 16 bits	Yes
8	2Fs	16	4.2	B	Japanese 16 bits	Yes
9	2Fs	18	4.2	B	Japanese 18 bits	Yes
10	2Fs	16	4.2	A	Philips 16 bits	Yes

Mode 3 is used in CD750 with NPC filter SM5840A and BSDAC SAA7350. For description of NPC filter and BS DAC we refer to Circuit Description CD93 part II orderno. 4822 725 24042

Mode 5 is used in CD710/720 with CC-DAC TDA1545.

Mode 6 is used in CD740 and CD911/921 with BCC-DAC TDA1549.

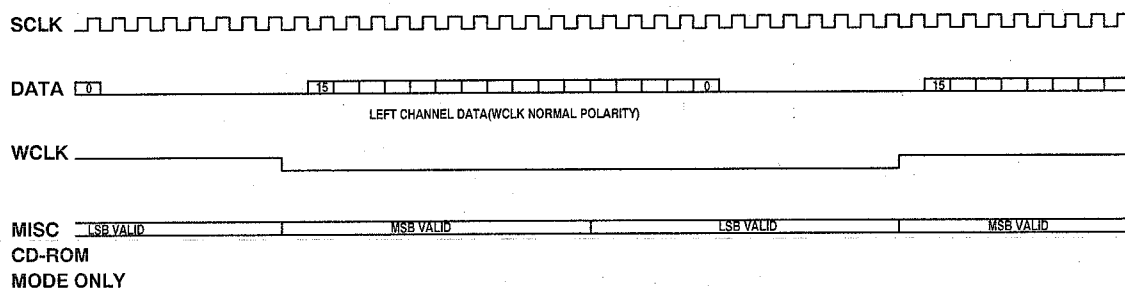

**Fig. A Philips I2S data format(16-bit word length shown)**

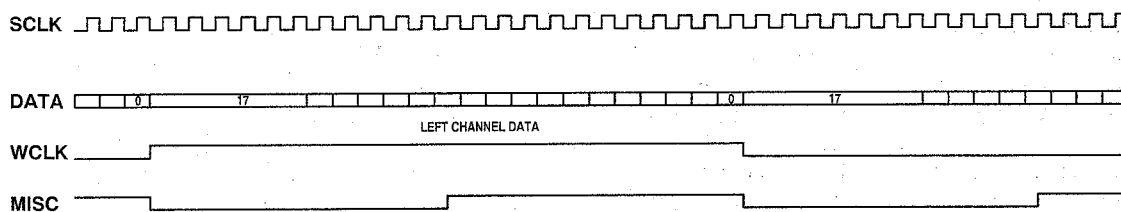

**Fig. B Japanese data format(18-bit word length shown)**

HAS1153

**Peak detector output**

In place of the CRC-bits(Cyclic Redundancy Check) 81 to 96, the peak detector information is added to the Q-channel data. The peak information corresponds to the highest audio level and is measured on positive peaks.

**Digital output interface**

The biphasemark digital output signal at pin DOBM is according to the format defined by the IEC958 specification. The digital audio output consists of 32-bit words transmitted in biphasemark code( two transitions for logic 1 and one transition for a logic 0). Left and right audio samples are transmitted alternately.

**Kill circuit**

The kill circuit detects digital silence by testing for an all-zero or all-ones data word in the left or right channel before the digital filter. The KILL pin 27 is active-LOW when digital silence has been detected in the LEFT channel for 200 ms, and V3 pin 26 is active-LOW when digital silence has been detected in the RIGHT channel for 200 ms.

When MUTE is active then the KILL outputs are forced LOW.

## 4. Stereo continuous calibration DAC TDA1545

### 4.1. General description

The TDA1545 is the first device of a new generation of digital-to-analog converters which embodies the innovative technique of continuous calibration. The largest bit-currents are repeatedly generated by one single current reference source.

This duplication is based upon an internal charge storage principle having an accuracy insensitive to ageing, temperature and process variations.

### 4.2. Block diagram

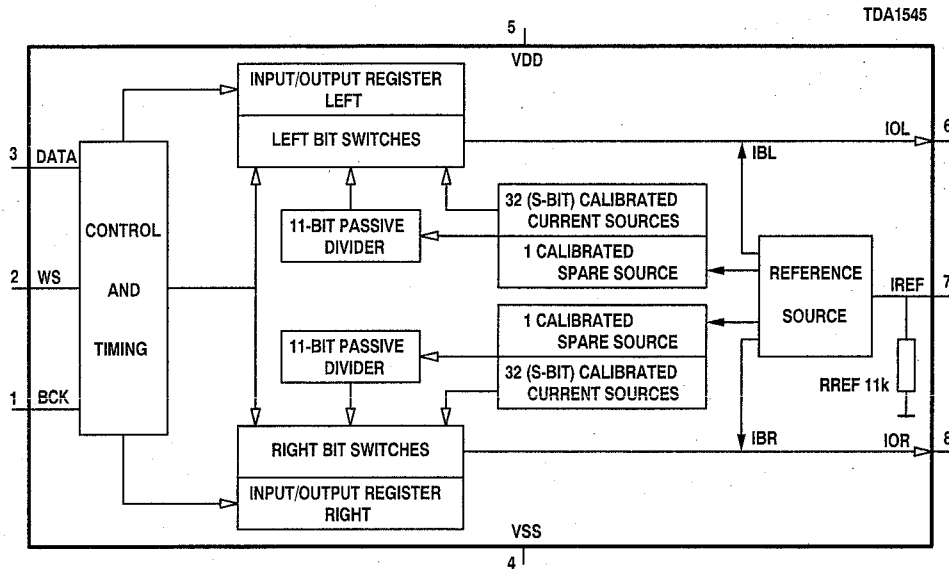

HAS1154

### 4.3. Pin description

PIN	SYMBOL	DESCRIPTION
1	BCK	bit clock input
2	WS	word select input
3	DATA	data input
4	GND	ground
5	VDD	positive supply voltage
6	IOL	left channel output
7	IREF	reference current input
8	IOR	right channel output

5.4. Functional description

General

The TDA1549 CMOS D/A bitstream continuous calibration converter incorporates internal digital filtering which increases the oversampling rate of 4fs input data to 96fs, and removes the spectral data components around 4fs, 8fs and 12fs.

A second-order noise shaper operating at 96fs outputs a five-bit data bitstream to the D/A converters. The filtering required for waveform smoothing and out-of-band noise reduction is achieved by simple first-order analog post-filtering.

Input

The circuit accepts four times oversampled data in 18-bit 2's complement standard Japanese format with MSB first. Left and right data-channel words are time multiplexed.

The bit clock(BCK) operates at 192fs i.e. 48 times the word select(WS) frequency of 4fs.

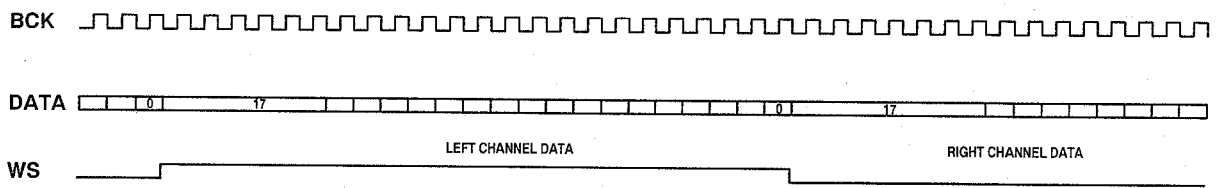

HAS1159

fig 5.1 : Input format

Oversampling filter

The oversampling filter consists of:

- A seventh order halfband low pass FIR filter which increases the oversampling rate from 4 times to 8 times. This removes the spectral components around 4fs and 12fs.
- A linear interpolation section which increases the oversampling rate to 16 times. This removes the spectral components around 8fs.
- A sample and hold section which provides another 6 times oversampling to 96 times. The zero-order hold characteristic of this sample and hold section plus the first order analog filtering remove the spectral components around 16fs.

The passband ripple is within 0.1dB. The stopband attenuation is >50dB around multiples of the sampling frequency.

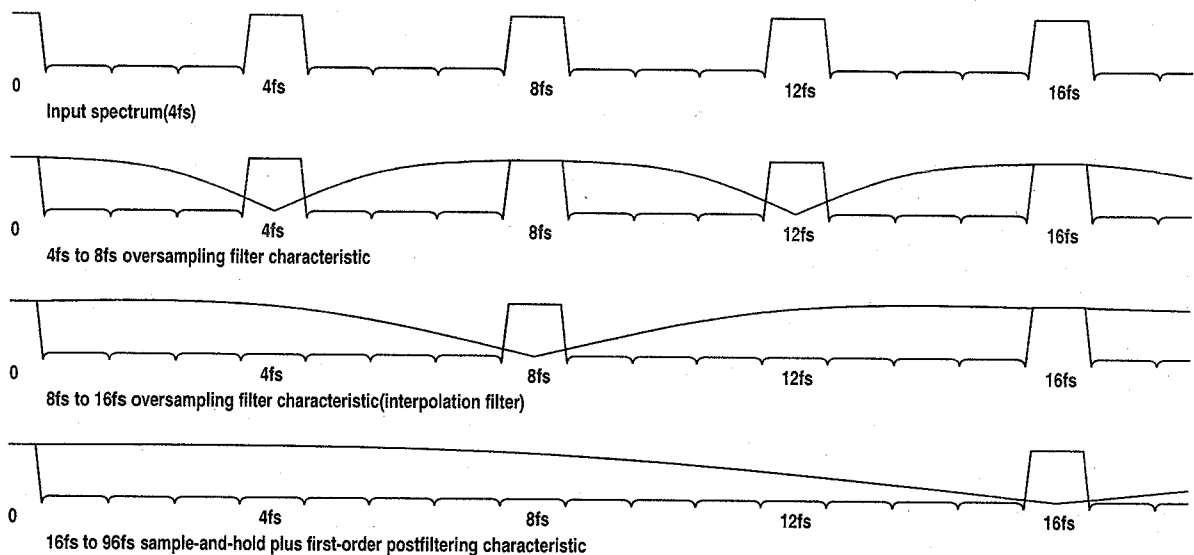

HAS1160

Fig 5.2 : Filter and noise shaper characteristics

### Noise shaper

The 2nd-order digital noise shaper converts the 18bit data at 96fs into a 5-bit bitstream, while shifting in-band quantisation noise to frequencies well above the audio band. For low signal levels the noise shaper output is a one-bitstream. This noise shaping technique used in combination with a special data code and bitstream converter enables extremely high signal-to-noise ratios to be achieved.

### Data encoder

The data encoder converts the five-bit 2's complement output data from the noise shaper to a 32-bit thermometer code.

In traditional unidirectional current converters, half the full-scale current flows to the output during small signal reproduction. The thermal noise and substrate crosstalk components, present in this current, severely restrict the dynamic range which can be attained. In this BCC-DAC true low-noise performance is achieved using a special data code and bidirectional current sources. The special data code guarantees that only small values of current flow to the output during small-signal passages while larger positive or negative signals are generated using the bidirectional sources. Furthermore, for every change in the 18 bit input sample only one current source or current sink is switched on. This intrinsically monotonic thermometer code ensures the high differential linearity, zero crossover distortion and superior signal-to-noise ratio associated with bitstream conversion.

### Continuous Calibration D/A converter.

The DAC currents(16 sources and 16 sinks) of each channel are repeatedly generated from one single reference current. See description of CC-DAC TDA1545.

### Operational amplifiers

High precision, low-noise amplifiers together with the internal conversion resistors RCONV1 and RCONV2 convert the converter output current to a voltage capable of driving a line output. This voltage is available at VOL and VOR(1.5Vrms typical). Connecting external capacitors CEXT1 and CEXT2 between resp. IOL and VOL, IOR and VOR provides the required first order postfiltering for the left and right channels. The RC combinations determine the first-order fall-off frequencies.

### Internal reference circuitry

Internal reference circuitry ensures that the output voltage signal is proportional to the supply voltage, thereby maintaining maximum dynamic range for supply voltages from 3.4 to 5.5V.



# SI

Wichtig für die Werkstatt!

Sachgebiet: AC 52 CD

Nummer 52139

Datum 30.09.1994

## Service Information

Betrifft: CD-Spieler CD710/CD720  
Service-Hinweise

Verteiler:

INTERN und EXTERN

### 1. Fokusfehler

Durch das Zusammenwirken von Eigenschaften des Laufwerkes CDM12.1 und des Servo-IC TDA1301 kann es bei einem ganz besonderen Plattenfehler ("white dropout" mit einer Dauer von ca. 100µs) zum Aussetzen der Fokussierung kommen, obwohl CD's mit diesem Fehler noch dem Standard entsprechen.

Zur Verbesserung der Fokussierung in solchen Fällen wird den beiden Photodioden D2 und D3 ein kleiner Offset-Strom zugeführt. Dazu sind am Servo-IC TDA1301 je ein Widerstand 3M9 von Pin 4 (VRH) nach Pin 5 und nach Pin 6 zugefügt worden.

Widerstand 3M9

4822 050 23905

### 2. Resetfunktion

Zur Verbesserung der Resetfunktion bei höheren Umgebungstemperaturen ist ab Woche 9425 der Resetpegel von 4V auf 4.5V erhöht worden durch Ändern des Widerstandes 3500 (Service Manual S.27; Decoderschaltbild).

~~3500 (560E) geändert in 150E~~

~~4822 116 52211~~

### 3. Decoder-IC

In Geräten aus Fertigung ab Woche 9420 ist das Decoder-IC 7100 (SAA7345GP/M2A) ersetzt worden durch SAA7345GP/M5.

Die beiden Ausführungen sind **n i c h t k o m p a t i b e l !**

Mit der Einführung der .../M5-Version ist die Oszillator-Beschaltung des Decoder-IC geändert worden:

- R3117 (330E) ersetzt durch Drahtbrücke
- C2112 hinzugefügt von Pin 13/7100 nach Masse  
C2112 22pF 4822 122 33191
- Resonator 1101 ersetzt durch eine andere Ausführung mit abweichender interner Kapazität  
1101 16.93MHZ 4822 242 81865

Bei Ersatz des Decoder-IC 7100 ist auf die verwendete Ausführung zu achten; beide Versionen sind verfügbar:

7100 SAA7345GP/M2A

4822 209 33166

7100 SAA7345GP/M5

4822 209 33339

4812 829 52139

Philips GmbH · Geschäftsbereich Service · Hamburg

Service  
Service  
Service

Soll eine IC-Version durch die andere ersetzt werden, dann muß die Oszillator-Beschaltung angepaßt werden (s. Abb.).

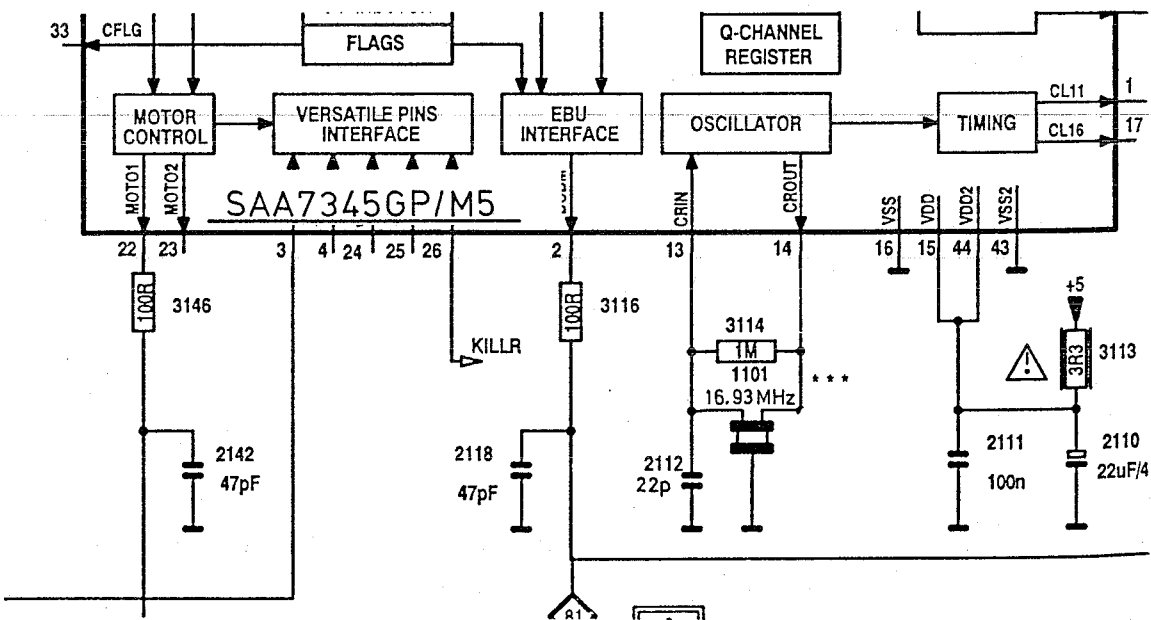
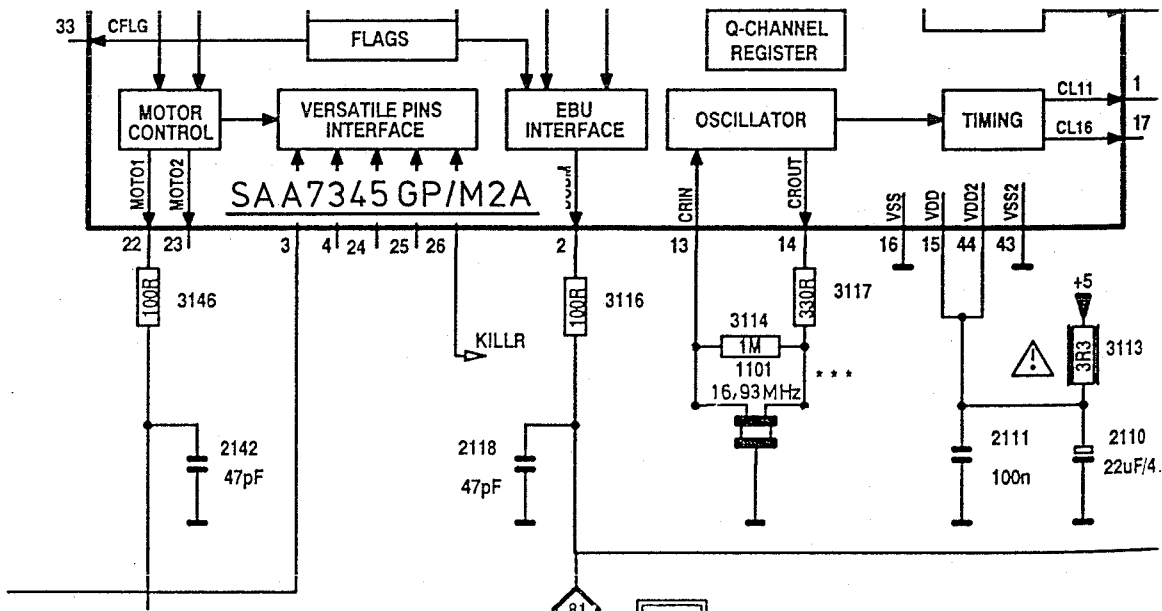

4. Netzteil

Von Beginn der Fertigung an ist als Diode 6540 (Service Manual, S.25) nicht der Typ 1N4002 sondern 1N4004 verwendet worden.

6540 1N4004

4822 130 83362

5. HF-Verstärker

Von Beginn der Fertigung an ist der Wert des Kondensators 2050 (Service Manual, S.26) nicht 330pF sondern 220pF.

2050 220pF

4822 122 10466



V02157  
V02093  
V02082  
V02080

## Compact disc

New key components of CD94 program

CD6 Decoder SAA7345

CC\_DAC TDA1545

BCC-DAC TDA1549

Service  
Service  
Service

# Circuit Description

## CONTENTS

### 1. Block diagrams

1.1. Block diagram CD710/CD720 .....	1-1
1.2. Block diagram CD740/CD911/CD921 .....	1-2
1.3. Block diagram CD750 .....	1-3

### 2. Circuit diagrams

2.1. Decoder circuit diagram .....	2-1
2.2. DAC circuit diagram CD710/CD720 .....	2-2
2.3. DAC circuit diagram CD740/CD911/CD921 .....	2-3
2.4. DAC circuit diagram CD750 .....	2-4

### 3. CD6 decoder SAA7345

3.1. General description .....	3-1
3.2. Block diagram .....	3-1
3.3. Pin description .....	3-2
3.4. Functional description .....	3-3

### 4. Stereo continuous calibration DAC TDA1545

4.1. General description .....	4-1
4.2. Block diagram .....	4-1
4.3. Pin description .....	4-1
4.4. Functional description .....	4-2

### 5. BCC-DAC TDA1549

5.1. General description .....	5-1
5.2. Block diagram .....	5-1
5.3. Pin description .....	5-2
5.4. Functional description .....	5-3



# PHILIPS

C. Des.

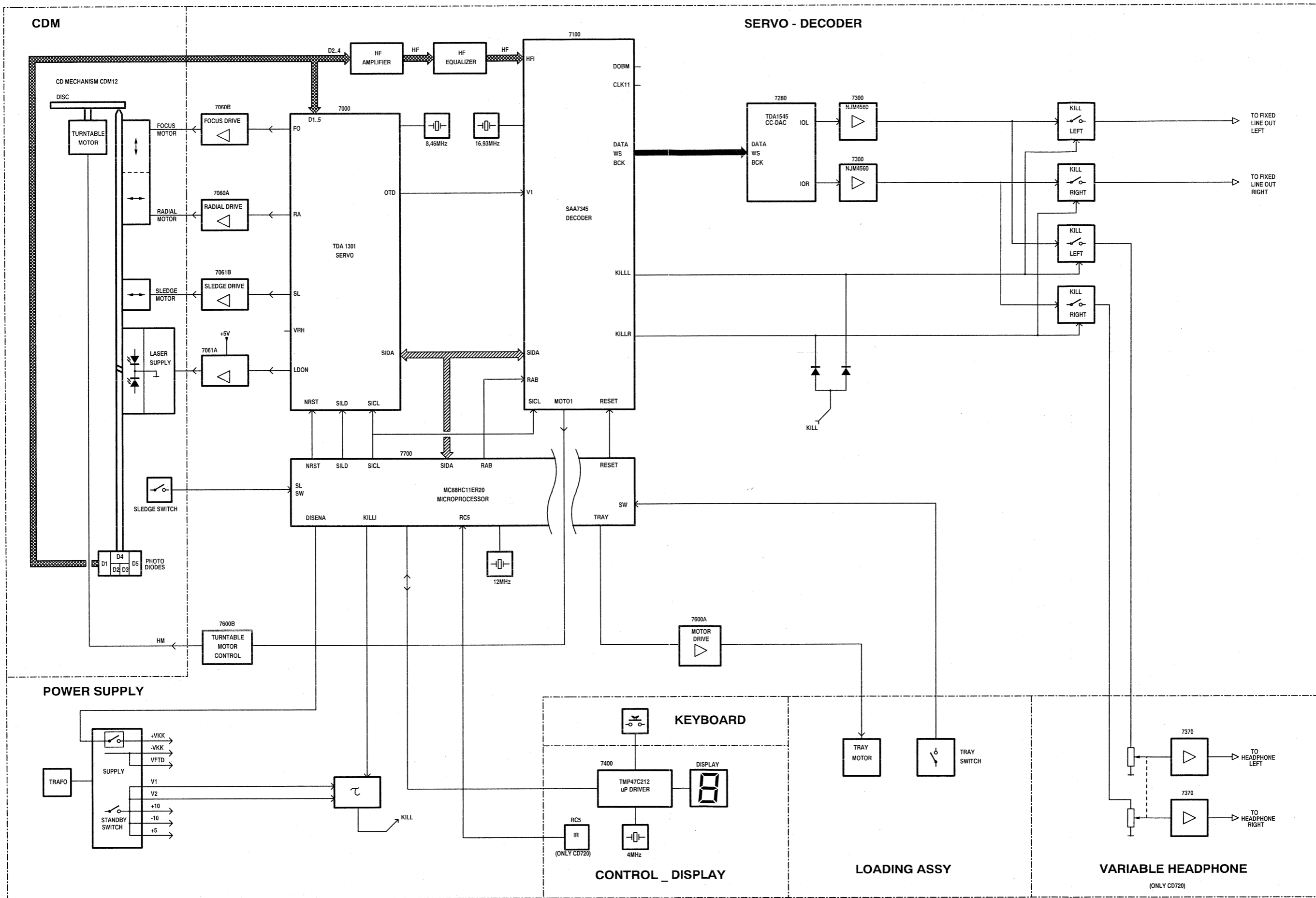

HAS1114  
9404

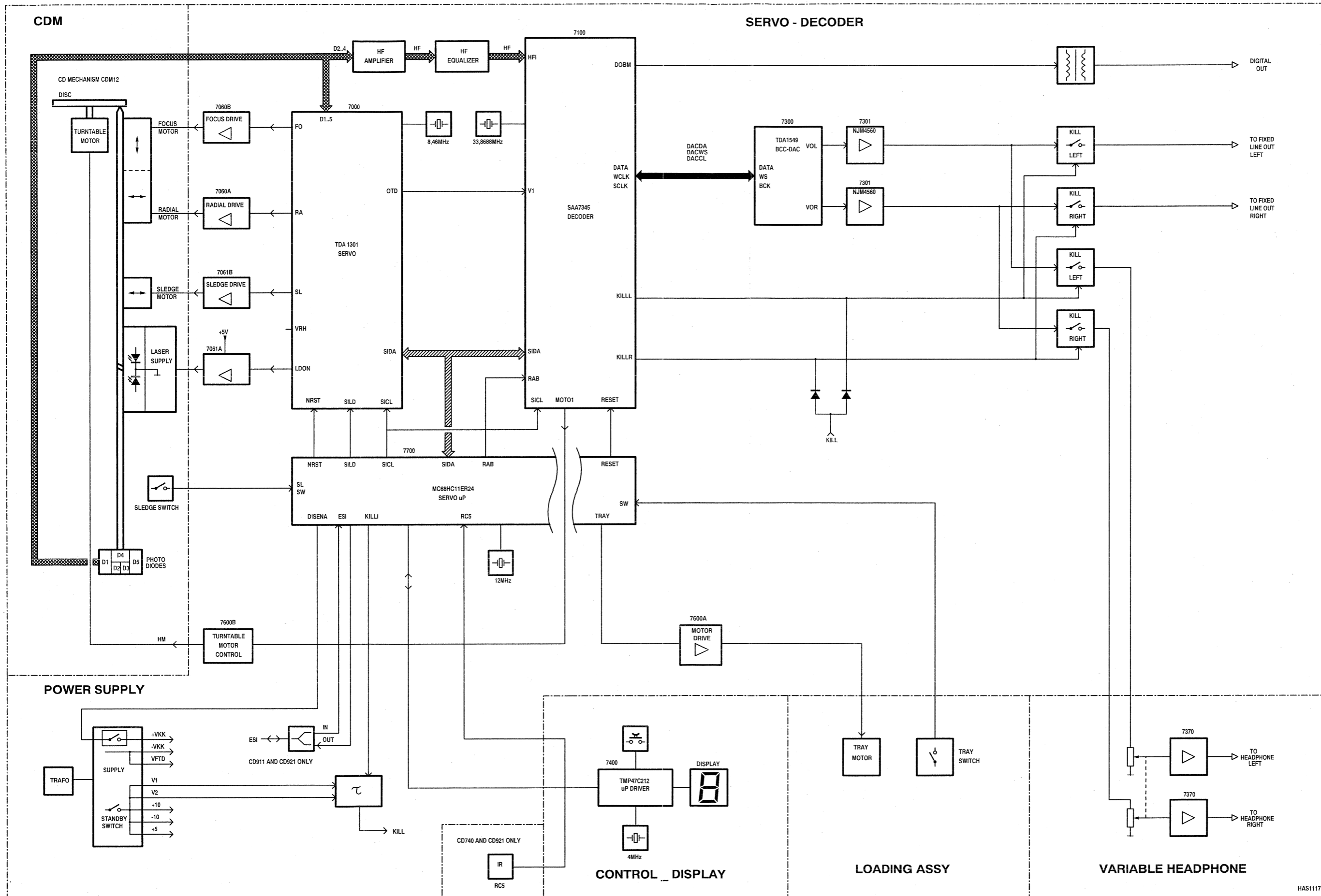

HAS1117

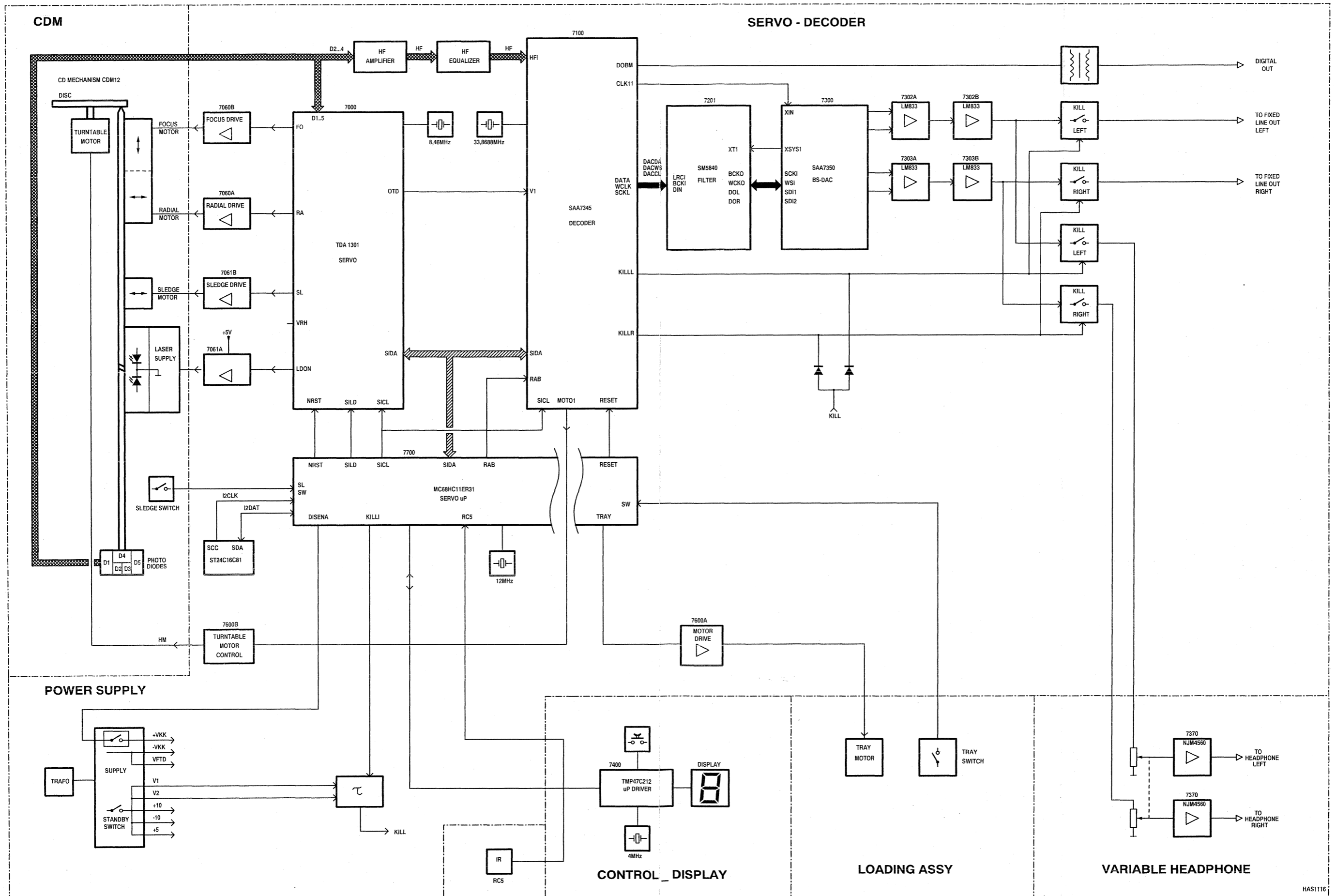

DECODER CIRCUIT DIAGRAM

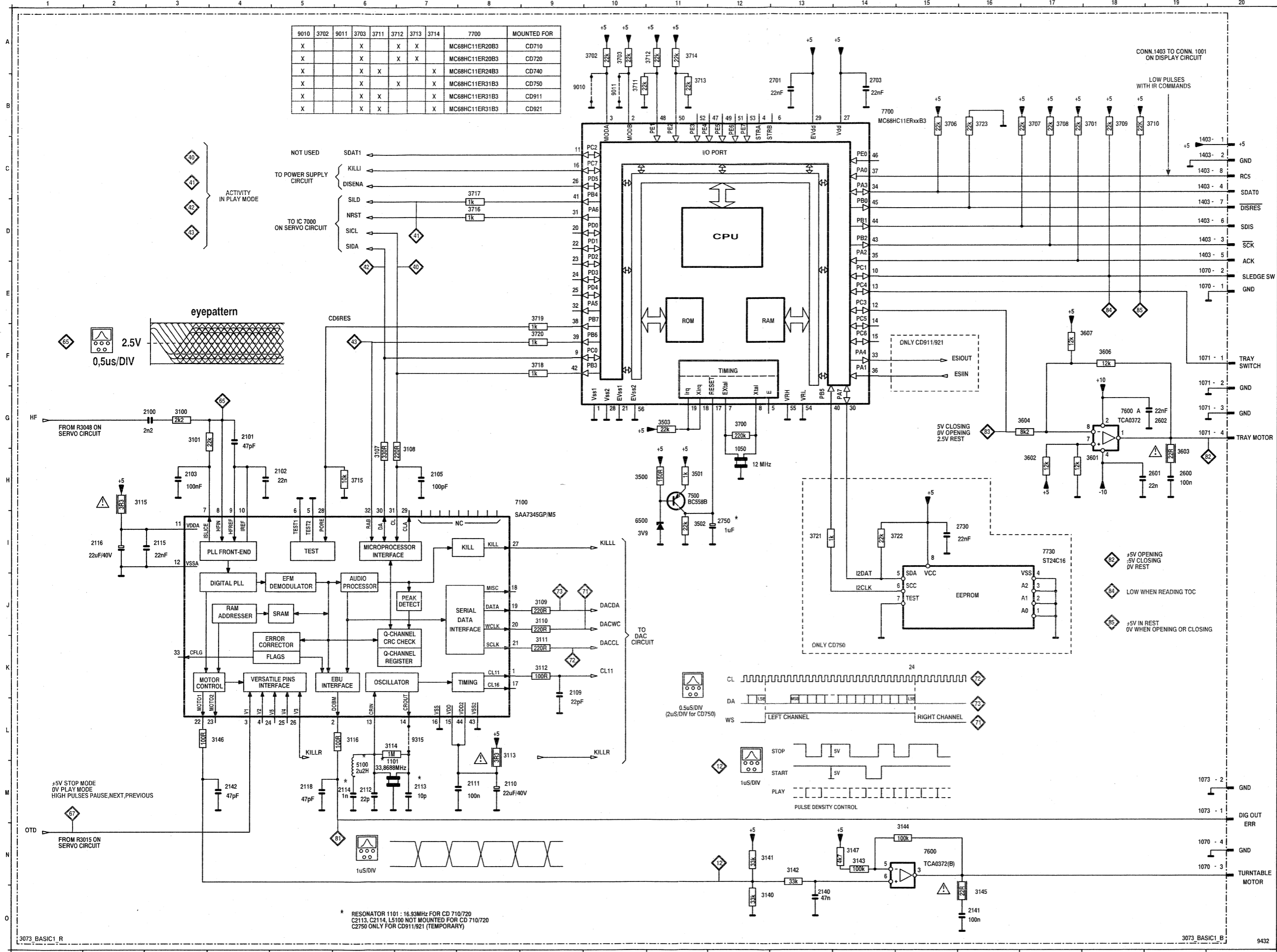

9010	3702	9011	3703	3711	3712	3713	3714	7700	MOUNTED FOR
X			X		X	X		MC68HC11ER20B3	CD710
X			X		X	X		MC68HC11ER20B3	CD720
X			X	X			X	MC68HC11ER24B3	CD740
X			X		X		X	MC68HC11ER31B3	CD750
X			X	X			X	MC68HC11ER31B3	CD911
X			X	X			X	MC68HC11ER31B3	CD921

1050 H12  
1070 E18  
1070 E19  
1070 N19  
1070 N19  
1071 F19  
1071 F19  
1071 G19  
1071 G19  
1073 M19  
1073 M19  
1101 M6  
1403 C19  
1403 C19  
1403 D19  
1403 D19  
1403 D19  
1403 D19  
1403 D19  
1403 D19  
2100 G2  
2101 G4  
2102 H4  
2103 H3  
2105 H7  
2109 K9  
2110 M8  
2111 M8  
2112 M8  
2113 M7  
2114 M6  
2115 J3  
2115 J3  
2118 M5  
2140 D13  
2141 D16  
2142 M4  
2600 H19  
2601 H19  
2602 G19  
2701 B13  
2703 B14  
2730 B16  
2750 H12  
3100 G3  
3101 G3  
3107 H6  
3108 H7  
3109 J9  
3110 J9  
3111 K9  
3111 K9  
3112 H8  
3114 L6  
3115 H2  
3116 L6  
3140 D12  
3141 H12  
3142 H13  
3143 N14  
3144 H16  
3145 H16  
3146 L4  
3147 N14  
3500 H10  
3501 H11  
3502 H11  
3503 G11  
3501 H18  
3602 H17  
3603 H19  
3604 G16  
3606 F18  
3607 F17  
3700 G12  
3701 B18  
3702 A10  
3703 A10  
3706 B15  
3707 B17  
3708 B17  
3709 B19  
3710 B19  
3711 B10  
3712 A11  
3713 H6  
3716 B8  
3717 C8  
3718 F9  
3719 E9  
3720 F9  
3721 H3  
3722 H5  
3723 B16  
5100 M6  
6500 H10  
7100 H9  
7500 H11  
7600 G18  
7600 N15  
7700 B14  
7730 H17  
8010 B9  
8011 B10  
8315 L7

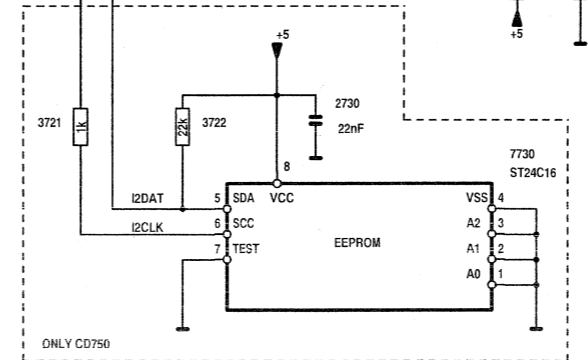
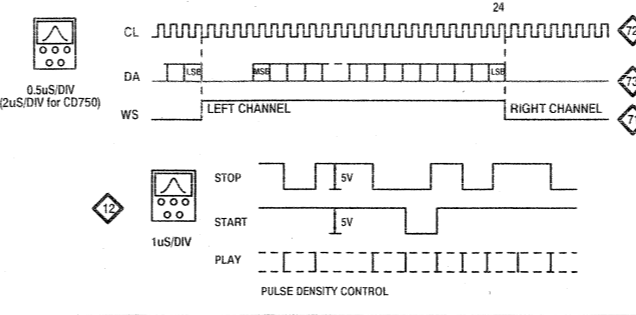
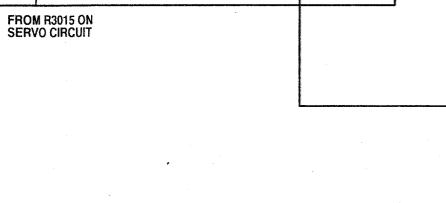
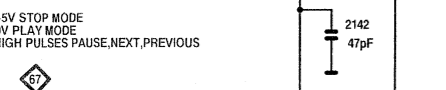
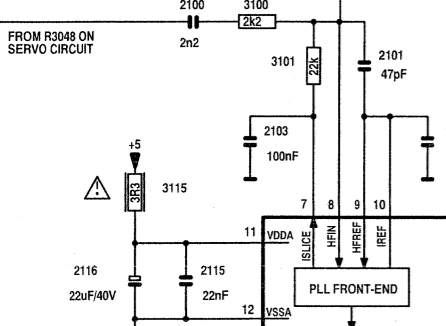
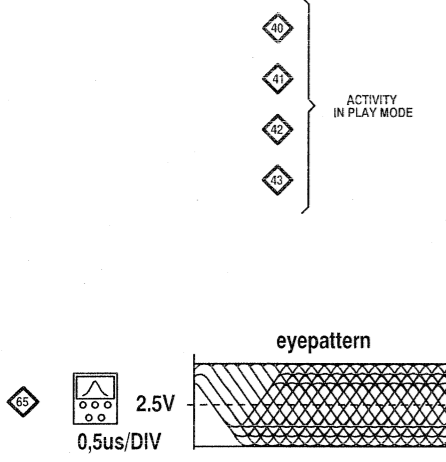

- 83 ±5V OPENING
- 84 ±5V CLOSING
- 85 ±5V IN REST
- 86 ±5V IN REST
- 87 ±5V IN REST
- 88 ±5V IN REST
- 89 ±5V IN REST
- 90 ±5V IN REST
- 91 ±5V IN REST
- 92 ±5V IN REST
- 93 ±5V IN REST
- 94 ±5V IN REST
- 95 ±5V IN REST
- 96 ±5V IN REST
- 97 ±5V IN REST
- 98 ±5V IN REST
- 99 ±5V IN REST
- 100 ±5V IN REST



DAC CIRCUIT DIAGRAM CD740/CD911/CD921

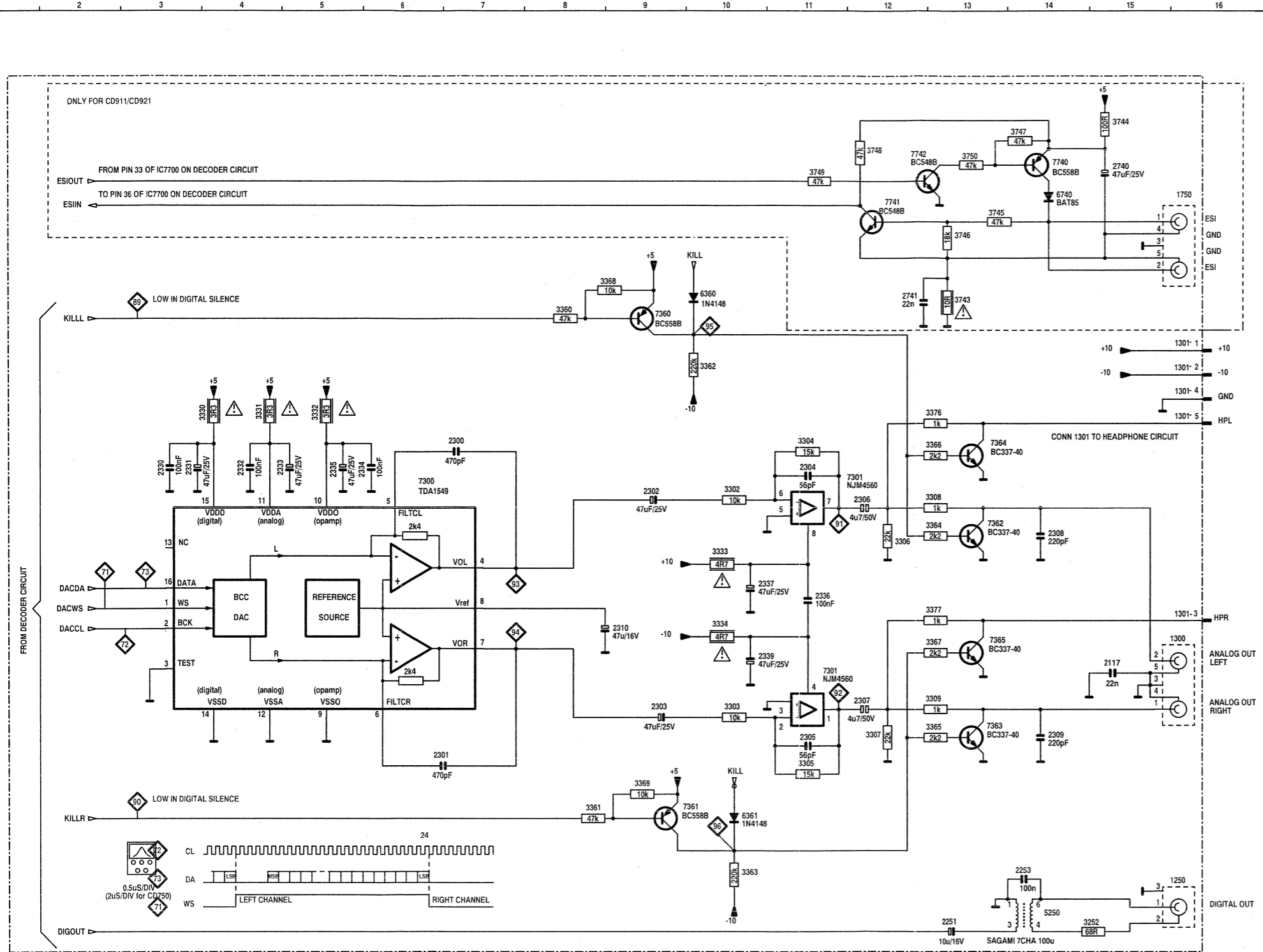

- 1250 K15
- 1300 H15
- 1301 D16
- 1301 E16
- 1301 H16
- 1301 E16
- 1301 E16
- 1750 C16
- 2117 H15
- 2251 L13
- 2253 K14
- 2300 F7
- 2301 I6
- 2302 F9
- 2303 I8
- 2304 F11
- 2305 I11
- 2306 F12
- 2307 I12
- 2308 G14
- 2309 I14
- 2310 H9
- 2330 F3
- 2331 F3
- 2332 F4
- 2333 F5
- 2334 F6
- 2335 F5
- 2336 H11
- 2337 G10
- 2339 H10
- 2340 B15
- 2741 D12
- 3252 L15
- 3302 F10
- 3303 I10
- 3304 F11
- 3305 J11
- 3306 G12
- 3307 I12
- 3308 F13
- 3309 J12
- 3330 E4
- 3331 E4
- 3332 E3
- 3333 G10
- 3334 H10
- 3360 D8
- 3361 J8
- 3362 E10
- 3363 K10
- 3364 G13
- 3365 I13
- 3366 F13
- 3367 H13
- 3368 D9
- 3369 J9
- 3376 E13
- 3377 H13
- 3743 D13
- 3744 B15
- 3745 C13
- 3746 C13
- 3747 B14
- 3748 B12
- 3749 B11
- 3750 B13
- 5250 K14
- 5250 D10
- 6361 J10
- 6740 C14
- 7300 F6
- 7301 H11
- 7301 F11
- 7350 D9
- 7361 J9
- 7362 G13
- 7363 I13
- 7364 F13
- 7365 H13
- 7740 B14
- 7741 C12
- 7742 B12



- 91 ANALOG SIGNAL
- 92 ANALOG SIGNAL
- 95 -5V IN PLAY MODE
- 96 +5V IN STOP MODE

DAC CIRCUIT DIAGRAM CD750

2-4

2-4

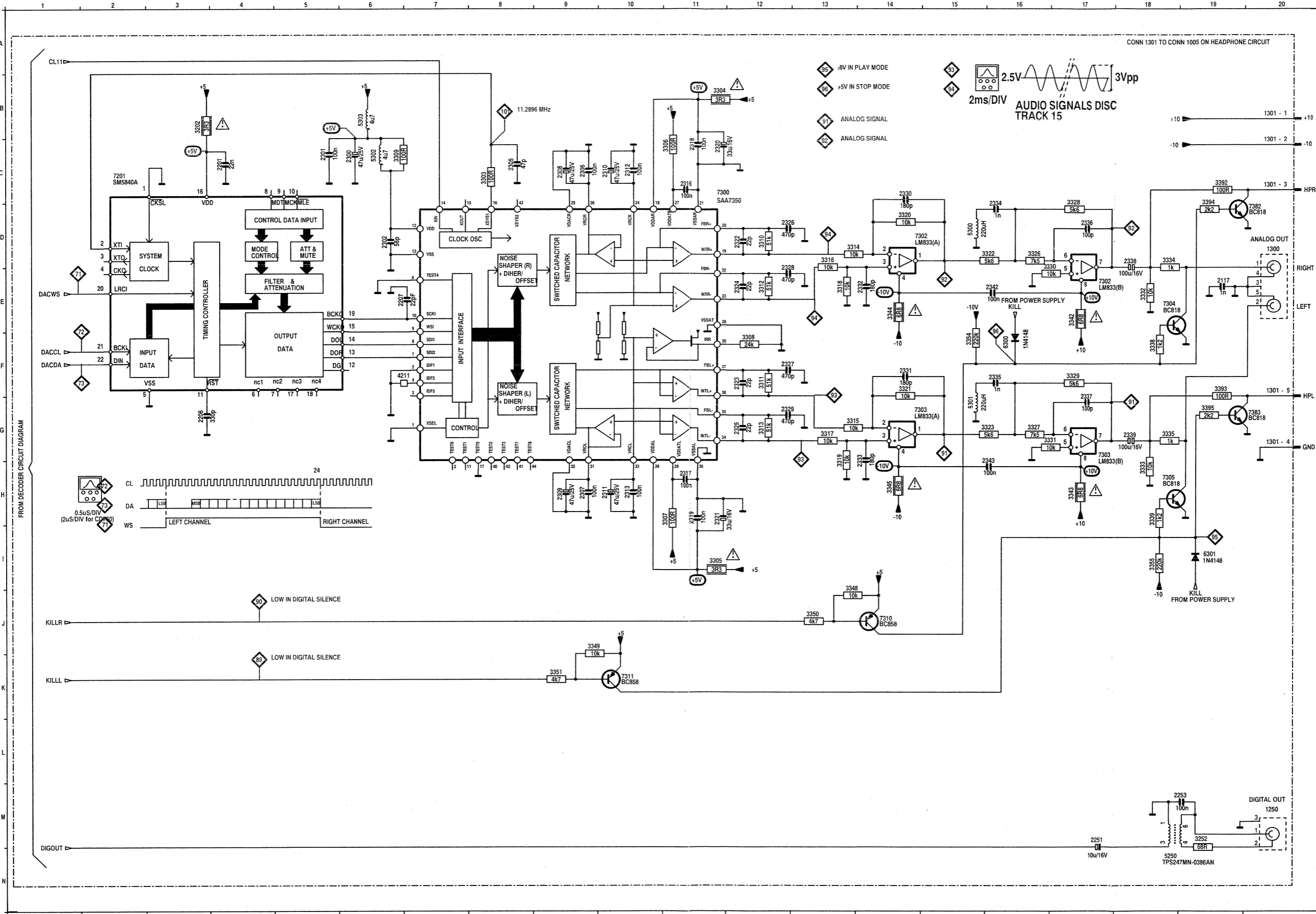

- 1250 M 7
- 1300 D20
- 1301 B20
- 1301 C20
- 1301 D20
- 1301 F20
- 2117 E19
- 2201 C 4
- 2206 G 3
- 2207 E 6
- 2251 M 5
- 2253 M 6
- 2300 C 6
- 2301 C 5
- 2302 D 6
- 2305 C 8
- 2306 C 9
- 2307 H 9
- 2308 C 9
- 2309 H 9
- 2310 C10
- 2312 C10
- 2313 H10
- 2316 C11
- 2317 H11
- 2318 C11
- 2320 C11
- 2321 H11
- 2322 D12
- 2325 F12
- 2326 D12
- 2327 F12
- 2328 E12
- 2329 G12
- 2330 C14
- 2331 F14
- 2332 E14
- 2333 G14
- 2334 D16
- 2335 F16
- 2336 D17
- 2337 G17
- 2338 D18
- 2339 G18
- 2342 E16
- 2343 H16
- 3202 B 3
- 3252 M 6
- 3303 C 8
- 3304 B11
- 3305 H 11
- 3306 C11
- 3307 H11
- 3308 F12
- 3309 C 6
- 3310 D12
- 3311 F12
- 3312 E12
- 3313 G12
- 3314 D13
- 3315 G13
- 3316 D13
- 3317 G13
- 3318 E13
- 3319 G13
- 3320 D14
- 3321 F14
- 3322 D16
- 3323 G16
- 3324 D16
- 3325 G16
- 3326 E16
- 3327 G16
- 3328 D17
- 3329 F17
- 3330 H17
- 3331 G17
- 3332 H18
- 3333 H18
- 3334 D18
- 3335 G18
- 3336 F18
- 3337 H18
- 3338 H18
- 3339 H18
- 3342 E17
- 3343 H17
- 3344 E14
- 3345 H14
- 3348 J13
- 3348 J 9
- 3350 J13
- 3351 K 9
- 3354 F15
- 3355 I18
- 3392 C19
- 3393 F19
- 3394 D19
- 3395 G19
- 4211 F 5
- 5250 N 6
- 5300 D15
- 5301 G15
- 5302 C 6
- 5303 B 6
- 6300 F16
- 6301 I19
- 7201 C 2
- 7300 C11
- 7302 D14
- 7302 E17
- 7303 G14
- 7303 G17
- 7304 E18
- 7305 H18
- 7310 J14
- 7311 K10
- 7382 D20
- 7383 G20



### 3. CD6 Decoder SAA7345

#### 3.1. General description

The SAA7345 incorporates the CD signal processing functions of decoding and digital filtering.

The device is equipped with on-board SRAM and includes additional features to reduce the processing required in the analog domain.

#### Features

- Integrated data slicer and clock regenerator
- Digital Phase-Locked Loop(PLL)
- Demodulator and EFM decoding
- Subcoding microprocessor serial interface
- Integrated programmable motor speed control
- Error correction and concealment functions
- Embedded SRAM for de-interleave and FIFO
- FIFO overflow concealment for rotational shock resistance

- Digital audio interface IEC958
- 2 to 4 times oversampling integrated digital filter
- Audio data peak level detection
- Versatile audio data serial interface
- Kill interface for DAC deactivation during digital silence.
- Double speed mode
- CD-ROM mode

#### 3.2. Block diagram

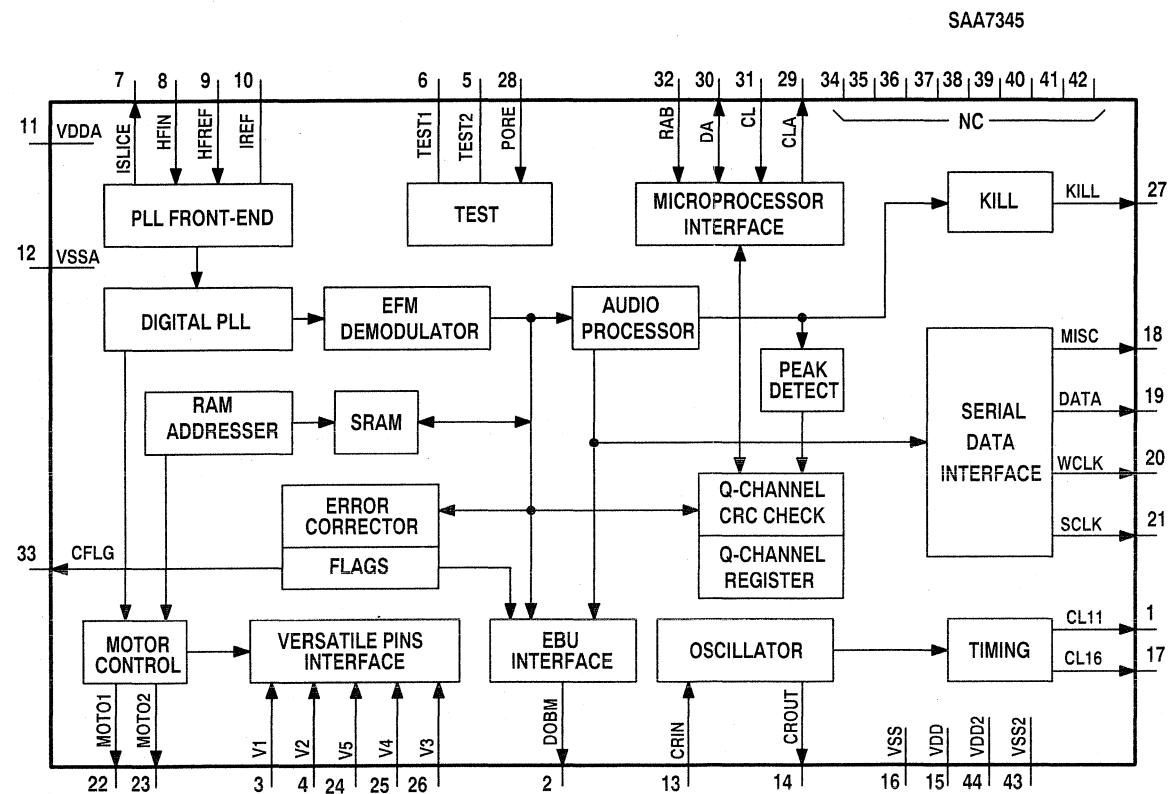

#### 3.3. Pin description

PIN	SYMBOL	DESCRIPTION
1	CL11	11.2896 MHz clock output(3-state)
2	DOBM	bi-phase mark output(externally buffered; 3-state)
3	V1	versatile input pin
4	V2	versatile input pin
5	TEST2	test input
6	TEST1	test input
7	ISLICE	current feedback from data slicer
8	HFIN	comparator signal input
9	HFREF	comparator common-mode input
10	IREF	reference current pin(nominally Vdd/2)
11	VDDA	analog supply
12	VSSA	analog supply
13	CRIN	crystal/resonator input
14	CROUT	crystal/resonator output
15	VDD	digital supply
16	VSS	digital supply
17	CL16	16.9344 MHz system clock output
18	MISC	general purpose DAC output(3-state)
19	DATA	serial data output(3-state)
20	WCLK	word clock output(3-state)
21	SCLK	serial bit clock output(3-state)
22	MOTO1	motor output 1; versatile(3-state)
23	MOTO2	motor output 2; versatile(3-state)
24	V5	versatile output pin
25	V4	versatile output pin
26	V3	versatile output pin
27	KILL	kill output; programmable(open-drain)
28	PORE	power-on reset enable input(active LOW)
29	CLA	4.2336 MHz microprocessor clock output
30	DA	interface data I/O line
31	CL	interface clock input line
32	RAB	interface read/write and aknowledge input
33	CFLG	correction flag output(open-drain)
34-42		no internal connection
43	VSS2	digital supply
44	VDD2	digital supply

4.4. Functional description

The basic operation of the continuous calibration DAC is illustrated in fig.4.1.

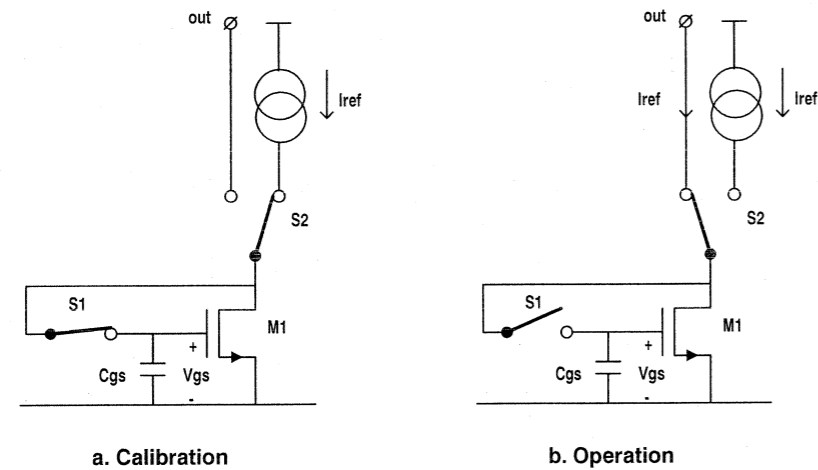

Fig.4.1 : Calibration principle

During calibration of the MOS current source, transistor M1 is connected as a diode via switch S1 to a reference current via switch S2. The voltage  $V_{gs}$  on the intrinsic gate-source capacitance  $C_{gs}$  of M1 is determined by the transistor characteristics. After calibration of the drain current to the reference value  $I_{ref}$ , the switch S1 is opened and S2 is switched to the other position. The gate-to-source voltage  $V_{gs}$  of M1 is not changed because the charge on  $C_{gs}$  is preserved.

Therefore the drain current of M1 will still be equal to  $I_{ref}$  and this exact duplicate of  $I_{ref}$  is now available at the  $I_{out}$  terminal. At the same time one source is switched to operation mode, another source is switched to calibration mode. The 32 current sources and the spare current source are continuously calibrated. (see fig.4.2.) The spare current is included to allow for continuous converter operation.

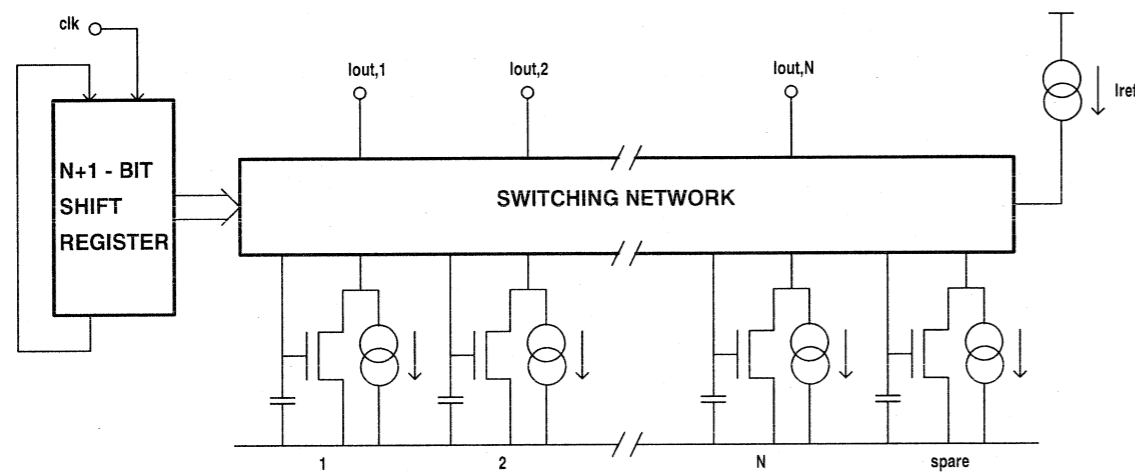
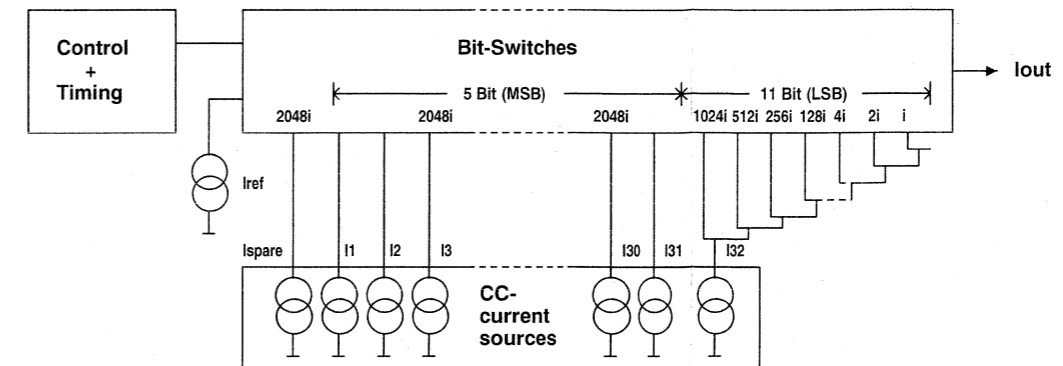

Fig.4.2 : Continuous Calibration

Source 1 supplies current  $I_{out,1}$  ; Source 2 supplies  $I_{out,2}$  etc...The spare source is calibrated with  $I_{ref}$ . In the next step source 1 is connected to  $I_{ref}$  for calibration and the spare source is connected to  $I_{out,1}$ .

After calibration, source 1 is activated again, the spare source is connected to  $I_{out,2}$  to allow calibration of source 2.... After calibration of the last source N, the spare source is calibrated again. The converter operation is during the continuous calibration not interrupted.



HAS1157

Fig.4.3 : Current sources in CC-DAC

31 sources supply the reference currents ( $I_1$ - $I_{31}$ ) for the 5 most significant bits (MSB). The output of  $I_{32}$  is connected to an 11-bit binary current divider consisting of 2048 transistors. A symmetrical offset decoding principle is incorporated and arranges the bit switching in such a way that the zero-crossing is performed only by the LSB currents.  
 Maximum  $I_{out}$  delivered by the DAC :  $(31 \times 2048i) + 1024i + 512i + 256i + 128i + \dots + 4i + 2i + i = 65535i$   
 The accuracy of the high coarse current combined with the symmetrical offset decoding method precludes zero-crossing distortion and ensures high quality audio reproduction.

The TDA1545A accepts input serial data formats of 16-bit word length. Left and right data words are time multiplexed. The most significant bit (bit 1) must always be the first. See also DAC output formats of decoder SAA7345. With a LOW level on the word select input (WS) data is placed in the right input register and with a HIGH level on the WS input data is placed in the left input register. The data in the input registers are simultaneously latched in the output registers which control the bit switches. An internal bias current ( $I_{BL}$  and  $I_{BR}$ ) is added to the full scale output current in order to achieve the maximum dynamic range at the outputs of the external opamps.

5. BCC-DAC TDA1549

5.1. General description

The TDA1549 combines the features of bitstream and continuous calibration D/A conversion.

A system of digital filtering, high oversampling, second-order noise shaping and continuous calibration D/A conversion ensures that only simple first-order analog filtering is required.

The circuit accepts 18-bit four times oversampled input data in standard Japanese format. Internal FIR filters remove the main spectral components and increase the sampling rate to 96 times. A second-order noise shaper converts this oversampled data to a five bit data stream. For low signal levels the converter operates in the one-bitstream mode with attendant high differential linearity.

Higher level signals are reproduced using the dynamic continuous calibration technique, guaranteeing high linearity independent of process variation, temperature effects and product ageing.

High-precision, low-noise amplifiers convert the D/A current to an output voltage capable of driving a line output. Externally connected capacitors perform the required first-order filtering so that no further post-filtering is required.

Internal reference circuitry ensures that the output voltage is proportional to supply voltage, thereby making optimal use of supply over a wide range(3.4V to 5.5V).

5.2. Block diagram

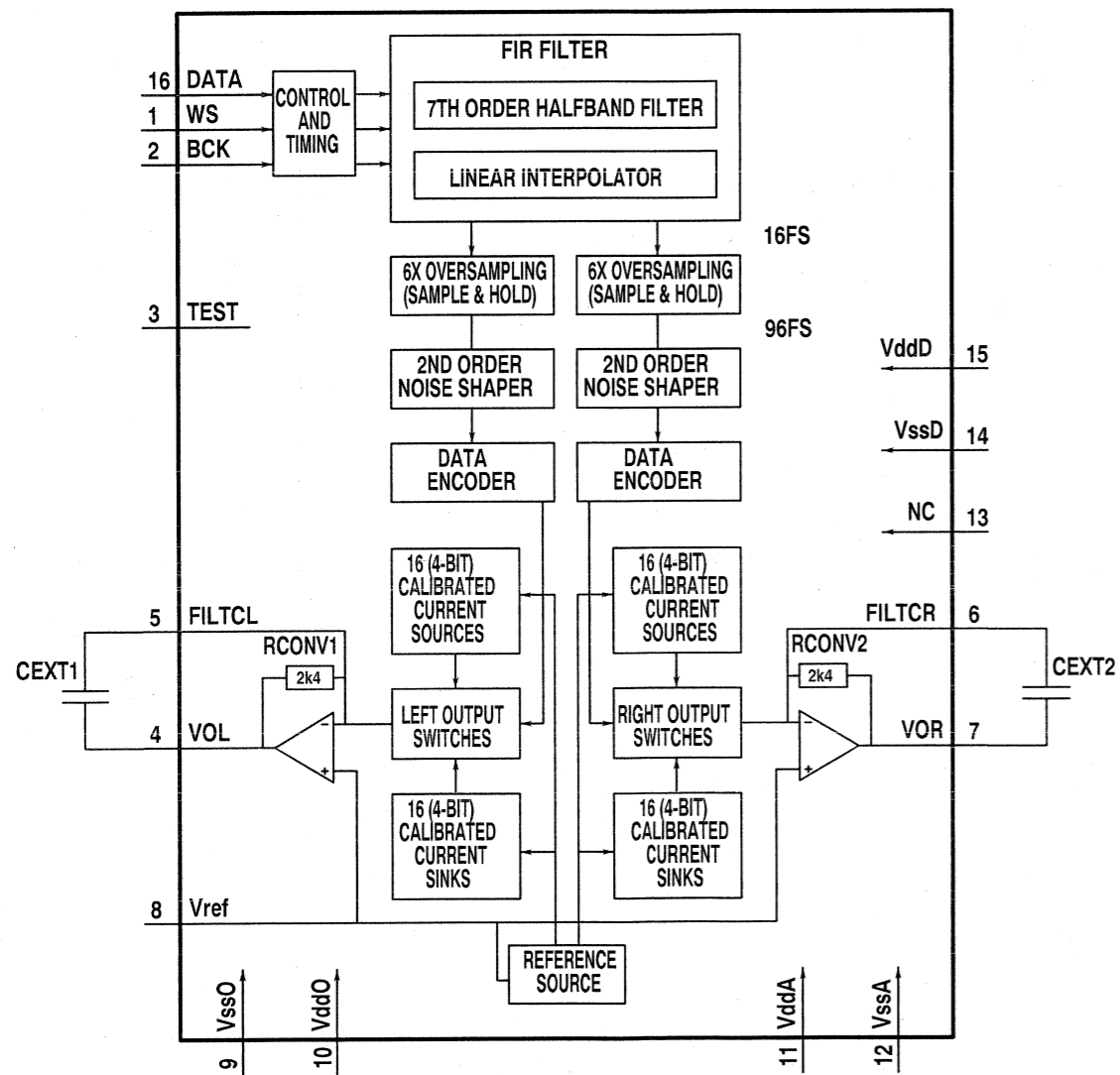

HAS1158

5.3. Pin description

PIN	NAME	DESCRIPTION
1	WS	word select input
2	BCK	bit clock input
3	TEST	test input
4	VOL	left channel output
5	FILTCL	Capacitor for left channel first order filter function
6	FILTCR	Capacitor for right channel first order filter function
7	VOR	right channel output
8	VREF	internal reference voltage for output channels
9	VssO	ground(Operational Amplifiers)
10	VddO	supply voltage(Operational Amplifiers)
11	VddA	supply voltage(analog)
12	VssA	ground(analog)
13		not connected
14	VssD	ground(digital)
15	VddD	supply voltage(digital)
16	DATA	data input

**Service**

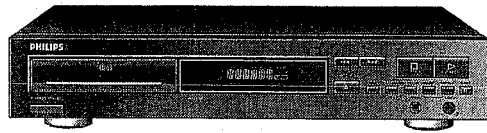

# Service Manual

**TABLE OF CONTENTS**

**PAGE**

1. Technical specifications	2
2. Instructions for use	3
3. Warnings	9
4. Servicing hints	10
5. Dismantling instructions	11
6. Service test program	12
7. CDM12 start up diagram	13
8. Faultfinding diagram CDM12	14
9. Faultfinding diagram decoder part	20
10. Specifications measurement	21
11. Abbreviations	22
12. Block diagram	23
13. Wiring diagram	24
14. Circuit diagrams and printed boards	
14.1. Power supply	25
14.2. Servo circuit diagram	26
14.3. Decoder circuit diagram	27
14.4. DAC circuit diagram	28
14.5. Main panel component side	29
14.6. Main panel solder side	30
14.7. Control & Display & Headphone	31
15. Loader	32
16. Mechanical Partslist	33
17. Exploded view	33
18. Electrical partslist	34



## TECHNICAL SPECIFICATIONS

### General

1.Mains voltage	/00B	: 230V (+6 -10%)
	/05B	: 240V ( $\pm 10\%$ )
	/01B	: 110V-127V/220V-240V
2.Mains frequency		: 50-60 Hz
3.Mains voltage selection only	/01B	: Voltage selector 2 positions
4.Power consumption mains	standby	: < 3W
	operated	: < 10W

### Remote Control(only CD720)

Internal: RC5

### Line output

1.Number of channels		: 2
2.Output voltage		: 2 Vrms $\pm$ 3 dB
3.Output resistance		: 1 k $\Omega$
4.Dynamic range (-60 dB)		: min. 84 dB from 20 Hz to 20 kHz
5.Unbalance left-right		: max. 1 dB
6.Channel separation		: min. 82 dB from 20 Hz to 20 kHz
7.Signal to noise ratio		: min. 83 dB from 20 Hz to 20 kHz
8.Total harmonic distortion + noise		: min. 70 dB from 20 Hz to 20 kHz
9.Frequency response		: max. $\pm$ 0.5 dB from 20 Hz to 20 kHz
10.Phase non-linearity		: max 7.0° from 20 Hz to 16 kHz
11.Automatic switched deemphasis with time constant 15/50 $\mu$ s		
12.Out-band attenuation		: min. 35 dB (above 40 kHz)

### Variable headphone(only CD720) (low end)

1.Output voltage		: max. 5 Vrms $\pm$ 3dB
2.Unbalance left-right		: max. $\pm$ 1.2 dB
3.Output resistance		: 120 $\Omega$
4.Load impedance range		: 30 $\Omega$ to 600 $\Omega$
5.Output power		: 0 to 30 mW into 30 $\Omega$ load
		: 0 to 50 mW into 150 $\Omega$ load
		: 0 to 30 mW into 600 $\Omega$ load

Audio specs in case of 600  $\Omega$  load at 4 Vrms voltage output

6.Signal to noise ratio		: min. 80 dB
7.Dynamic range		: min. 70 dB (20 Hz -20 kHz)
8.Total harmonic distortion		: min. 60 dB (20 Hz - 20 kHz)
9.Channel separation		: min. 70 dB (1 kHz)
		: min. 65 dB (31.5 Hz - 16 kHz)

### Dimensions and weight

1.Apparatus tray closed		: WxDxH 435 x 260 x 74/90 mm
2.Apparatus tray open		: WxDxH 435 x 405 x 74/90 mm
3.Weight		: 3 kg

### Optical read-out system

1.Laser type		: Semiconductor AlGaAs
2.Wavelength		: 780 nm $\pm$ 20 nm
3.Light output (c.w.)		: max. 0.5 mW

DIODES			MAINS VOLTAGE		
6360	4822 130 30621	1N4148	5500 ▲	4822 146 31337	MAINS TRANSFO /00B
6361	4822 130 30621	1N4148	5500 ▲	4822 146 31339	MAINS TRANSFO /05B
6400	4822 130 30613	BAW62	5500 ▲	4822 146 31338	MAINS TRANSFO /01B
6401	4822 130 30613	BAW62			
6402	4822 130 30613	BAW62			
6500	4822 130 31981	BZX79-C3V9			
6535	5322 130 30684	1N4002GP			
6536	5322 130 30684	1N4002GP			
6537	5322 130 30684	1N4002GP			
6538	5322 130 30684	1N4002GP			
6540	5322 130 30684	1N4002GP			
6541	4822 130 34278	BZX79-C6V8			
6542	4822 130 30621	1N4148			
6543	5322 130 30684	1N4002GP			
6544	4822 130 30621	1N4148			
6560	5322 130 30684	1N4002GP			
6561	5322 130 30684	1N4002GP			
6562	4822 130 31981	BZX79-C3V9			
TRANSISTORS & IC'S					
7000	4822 209 31064	TDA1301T/N1			
7040	4822 130 40902	BF240			
7041	4822 130 40937	BC548B			
7042	4822 130 44197	BC558B			
7043	4822 130 40937	BC548B			
7044	4822 130 40937	BC548B			
7060	4822 209 72587	TCA0372			
7061	4822 209 72587	TCA0372			
7100	4822 209 33166	SAA7345GP/M2A			
7280	4822 209 33164	TDA1545AT/N2			
7300	4822 209 83274	NJM4560D			
7360	4822 130 44121	BC338			
7361	4822 130 44121	BC338			
7362	4822 130 44121	BC338			
7363	4822 130 44121	BC338			
7364	4822 130 44197	BC558B			
7365	4822 130 44197	BC558B			
7370	4822 209 82362	NJM4556D			
7400	4822 209 30249	TMP47C212AN			
7500	4822 130 44197	BC558B			
7535 ▲	4822 209 80891	MC7805CT			
7540	5322 209 62115	MC79L15AC			
7541	4822 130 40937	BC548B			
7542	4822 130 44121	BC338			
7543	4822 130 44197	BC558B			
7600	4822 209 72587	TCA0372			
7650	4822 130 44197	BC558B			
7700	4822 209 33249	MC68HC11ER20/P159-07			