

Service
Service
Service

/00/06/11/17
/00S/06S/11S/17S



Service Manual

Introduction of CDR880

For CDR880 we refer to the service manual of CDR870 service code number 4822 725 25241 except the following differences:

Mechanical parts:

ITEM	NAME	CDR880/00/06/11/17	CDR880/00S/06S/11S/17S
1	FRONT ASSY	4822 459 04978	4822 459 04981
9	POWER ROD	= CDR870	4822 402 11065
51	LEVEL KNOB	= CDR870	4822 410 11809
53	VOLUME KNOB	= CDR870	4822 410 11811
65	TRAY FRONT	= CDR870	4822 459 04982
151	COVER	= CDR870	4822 442 01369
312-313	CINCH CABLE GOLD	4822 321 23116	4822 321 23116



CDR MODULE

The CDR module used in CDR880 is also different and can be ordered with service code number 4822 214 12745.

Electrical parts

A modified connector board to improve recordings via optical input has been implemented in CDR880. The optical devices have been changed into a new type.

Optical receiver position 1520: GP1F32R. Service code number: 4822 218 11987.

Optical transmitter position 1521: GP1F32T. Service code number: 4822 130 10845.

See added circuit diagram and PCB drawing.



© Copyright 1998 Philips Consumer Electronics B.V. Eindhoven, The Netherlands

All rights reserved. No part of this publication may be reproduced, stored in a retrieval system or transmitted, in any form or by any means, electronic, mechanical, photocopying, or otherwise without the prior permission of Philips.

Published by M.T. 9818 Service MMA P.I.A. Hasselt

Printed in The Netherlands

Subject to modification

GB 4822 725 25245



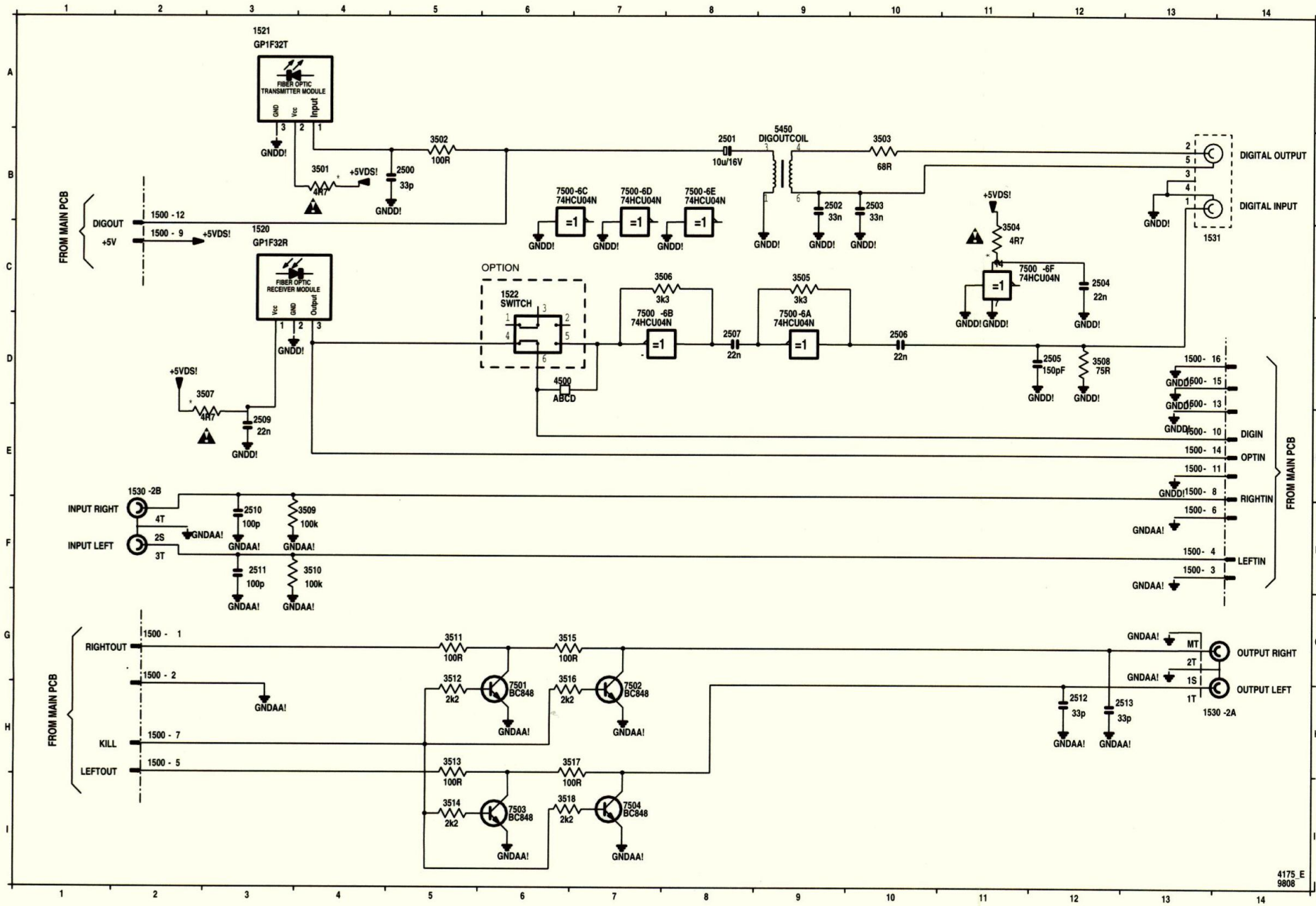

- 1500 G 2
- 1500 G 2
- 1500 F13
- 1500 F13
- 1500 H 2
- 1500 F13
- 1500 H 2
- 1500 E13
- 1500 C 2
- 1500 E13
- 1500 E13
- 1500 B 2
- 1500 D13
- 1500 E13
- 1500 D13
- 1500 D13
- 1520 C 3
- 1521
- 1522 C 6
- 1530 H13
- 1530 E 2
- 1531 C13
- 2500 B 5
- 2501 B 8
- 2502 B 9
- 2503 B10
- 2504 C12
- 2505 D12
- 2506 D10
- 2507 D 2
- 2509 E 3
- 2510 F 3
- 2511 F 3
- 2512 H12
- 2513 H13
- 3501 B 4
- 3502 B 5
- 3503 B10
- 3504 C11
- 3505 C 9
- 3506 C 8
- 3507 D 3
- 3508 D12
- 3509 F 4
- 3510 F 4
- 3511 G 5
- 3512 G 6
- 3513 H 5
- 3514 I 5
- 3515 G 6
- 3516 G 6
- 3517 H 7
- 3518 I 6
- 4500 D 6
- 4500 B 8
- 7500 D 9
- 7500 D 7
- 7500 B 6
- 7500 B 7
- 7500 B 8
- 7500 C11
- 7501 H 6
- 7502 H 7
- 7503 G 6
- 7504 I 7

4175 E
9808

