

CDR570
 CDR770
 CDR775
 CDR930
 CDR950

Service
 Service
Service

Service Manual



Contents	Page
1 Introduction	2
2 Safety- and maintenance instructions, warnings and notes	3
3 Directions for use	6
4 <i>Mechanical instructions</i>	7
Loader CDL4009	7
CDL3800	8
Demounting CDL3800	9
Exploded view CDM3800	11
Cleaning lens	12
Lubricating	13
5 <i>Service modes, faultfindingtrees and repair tips</i>	14
Service modes	14
Faultfindingtrees	18
6 Blockdiagrams	33
7 Electrical diagrams and PWB's	34
8 Alignments, Adjustments	75
9 Circuit description	76
List of abbreviations	77
10 Sparepart list	85

©Copyright reserved 2000 Philips Consumer Electronics B.V. Eindhoven, The Netherlands. All rights reserved. No part of this publication may be reproduced, stored in a retrieval system or transmitted, in any form or by any means, electronic, mechanical, photocopying, or otherwise without the prior permission of Philips.



PHILIPS

1. Technical Specifications/Introduction.

In this document the important issues for the mechanical and electrical testing, adjusting, checking and diagnosing of the Digital Audio CDR Module such as applied in so-called 3rd generation CDR recorders is described.

In this first chapter is presented the introduction of the repair manual for 2nd line repair workshops. It contains the repair instructions of the CDR Module CDL4009 + Mainboard 4228. All modules consist of the same loader + CDM part, the mounting of the components on the Mainboard deviates from each other. For that reason a separate CDR-module has been defined for each type/modelnumber.

On top of that: Each mainboard connected to another CDM has to be adjusted before that module can be used. To have this module on component level repaired this second line service (repair) manual has to be used in combination with the "first" line service manual of mentioned typenumber. As long as the adjustment instructions can not be carried out, the module has to be exchanged by an adjusted one from Service stock in case of repairs concerning CDM and/or Servo circuits.

Chapter 2 contains the required safety instructions, in chapter 3 a referring to the directions for use, as published in the typenumber Service Manual, is made.

In chapter 4 the mechanical exploded view of the complete module, the loading part and the CDM3800 is presented. This chapter also includes the mounting, demounting, cleaning and greasing instruction.

In chapter 5 the internal selfdiagnostics without opening the set and use of other tools is described in the service modes. The faultfinding trees and repair suggestions like the power supply voltages for proper functioning of the mainboard are indicated there too. This chapter also contains initialising and reset, concerned measuring points are highlighted. For proper functioning of all ICs the clockfrequencies have to be tested and the importance of derived clockfrequencies is shown. and how to operate with the menu driven diagnostics. Via a PC connection (serial input socket RS232C) the Menu Driven Diagnostics feature is started.

To improve the interactivity and communication with the set/module the COMPAIR (the for service designed computer aided repair) tool is supported too by this CDR generation. Details to be defined soonest and will be published by a service information bulletin later on.

Via blockdiagrams of applied boards the common issues of all boards are shown and in short explained in chapter 6.

In chapter 7 the circuit diagrams and printed wiring boards with important measuring points are shown.

The adjustment of the laser current (only one important and necessary adjustment has to be carried out, the rest of the adjustments are calculated from that parameter onwards) will be presented in chapter 8. The needed PC program is under investigation now and with the implementation of COMPAIR this adjustment action will be explained. The method how to align the software, if needed, is indicated here.

In chapter 9 reference is made to existing 3rd generation circuit description in which publication a lot of details about the functioning of the set is explained.

Also the list of abbreviations is inserted here.

Finally a survey of applied components and corresponding service ordering numbers is given in chapter 10.

As the Mainboard 4228 is designed to be applied for several modelnumbers this board contains a lot of optional components.

The most extended board is modelnumber CDR775 where double speed dubbing feature is applied too.

2. Safety and Maintenance instructions warnings and notes

GB WARNING

All ICs and many other semi-conductors are susceptible to electrostatic discharges (ESD). Careless handling during repair can reduce life drastically.

When repairing, make sure that you are connected with the same potential as the mass of the set via a wrist wrap with resistance.

Keep components and tools also at this potential.

ESD



NL WAARSCHUWING

Alle IC's en vele andere halfgeleiders zijn gevoelig voor elektrostatische ontladingen (ESD).

Onzorgvuldig behandelen tijdens reparatie kan de levensduur drastisch doen verminderen.

Zorg ervoor dat u tijdens reparatie via een polsband met weerstand verbonden bent met hetzelfde potentiaal als de massa van het apparaat.

Houd componenten en hulpmiddelen ook op hetzelfde potentiaal.

F ATTENTION

Tous les IC et beaucoup d'autres semi-conducteurs sont sensibles aux décharges statiques (ESD).

Leur longévité pourrait être considérablement écourtée par le fait qu'aucune précaution n'est prise à leur manipulation.

Lors de réparations, s'assurer de bien être relié au même potentiel que la masse de l'appareil et enfiler le bracelet serti d'une résistance de sécurité.

Veiller à ce que les composants ainsi que les outils que l'on utilise soient également à ce potentiel.

D WARNUNG

Alle IC und viele andere Halbleiter sind empfindlich gegen elektrostatische Entladungen (ESD).

Unvorsichtige Behandlung bei der Reparatur kann die Lebensdauer drastisch vermindern. Sorgen sie dafür, das Sie im Reparaturfall über ein Pulsarmband mit Widerstand mit dem Massepotential des Gerätes verbunden sind.

Halten Sie Bauteile und Hilfsmittel ebenfalls auf diesem Potential.

I AVVERTIMENTO

Tutti IC e parecchi semi-conduttori sono sensibili alle scariche statiche (ESD).

La loro longevità potrebbe essere fortemente ridotta in caso di non osservazione della più grande cauzione alla loro manipolazione. Durante le riparazioni occorre quindi essere collegato allo stesso potenziale che quello della massa dell'apparecchio tramite un bracciale a resistenza.

Assicurarsi che i componenti e anche gli utensili con quali si lavora siano anche a questo potenziale.

GB

Safety regulations require that the set be restored to its original condition and that parts which are identical with those specified be used.

NL

Veiligheidsbepalingen vereisen, dat het apparaat in zijn oorspronkelijke toestand wordt terug gebracht en dat onderdelen, identiek aan de gespecificeerde worden toegepast.

D

Bei jeder Reparatur sind die geltenden Sicherheitsvorschriften zu beachten. Der Originalzustand des Gerats darf nicht verändert werden. Für Reparaturen sind Original-Ersatzteile zu verwenden.

I

Le norme di sicurezza esigono che l'apparecchio venga rimesso nelle condizioni originali e che siano utilizzati pezzi di ricambio identici a quelli specificati.

F

Les normes de sécurité exigent que l'appareil soit remis à l'état d'origine et que soient utilisées les pièces de rechange identiques à celles spécifiées.



**CAUTION
VARO!
WARNING
ADVERSEL
DANGER
VORSICHT**

INVISIBLE LASER RADIATION WHEN OPEN. AVOID EXPOSURE TO BEAM.

AVATTAESSA OLET ALTIINA NÄKYMÄTTÖMÄLLE LASER SÄTTEILYLLE ÄLÄ KATSO SÄTEESIEN.

ÖSYNLIG LASERSTRÅLNING NÄR DENNA DEL ÄR ÖPPNAD BETRAKTA EJ STRÅLEN.

USYNLIG LASERSTRÅLING VED ÅBNING. UNDGÅ UNSÆTTELSE FOR STRÅLING.

INVISIBLE LASER RADIATION WHEN OPEN. AVOID DIRECT EXPOSURE TO BEAM.

UNSICHTBARE LASERSTRAHLUNG WENN ABEDECKUNG GEÖFFNET. NICHT DEM STRAHL AUSSETZEN.



SHOCK, FIRE HAZARD SERVICE TEST:

CAUTION: After servicing this appliance and prior to returning to customer, measure the resistance between either primary AC cord connector pins (with unit NOT connected to AC mains and its Power switch ON), and the face or Front Panel of product and controls and chassis bottom,

Any resistance measurement less than 1 Megohms should cause unit to be repaired or corrected before AC power is applied, and verified before return to user/customer.

Ref.UL Standard NO.1492.

NOTE ON SAFETY:

Symbol  : Fire or electrical shock hazard. Only original parts should be used to replace any part with symbol . Any other component substitution (other than original type), may increase risk of fire or electrical shock hazard.

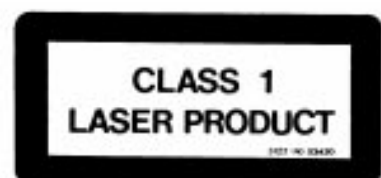

Pour votre sécurité, ces documents doivent être utilisés par des spécialistes agréés, seuls habilités à réparer votre appareil en panne.

SERVICING HINTS

In the set, chip components have been applied. For disassembly and assembly check the figure below.

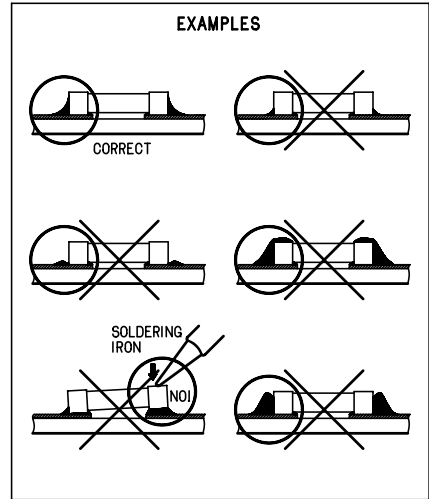
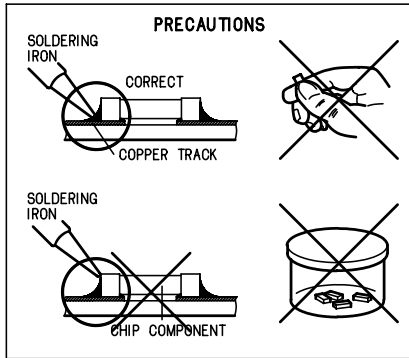
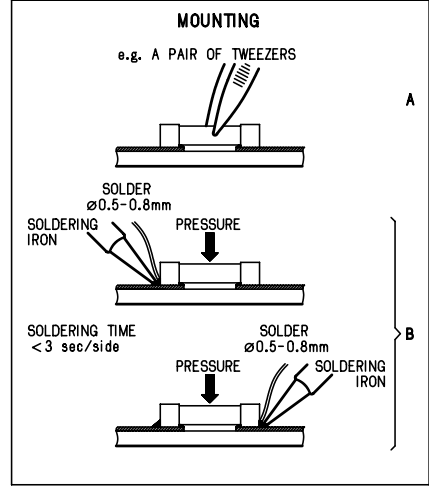
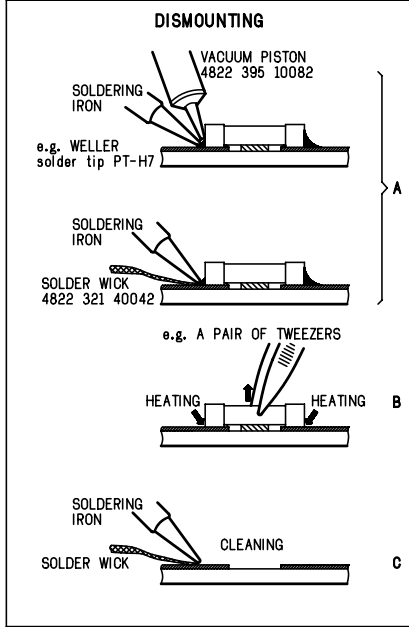
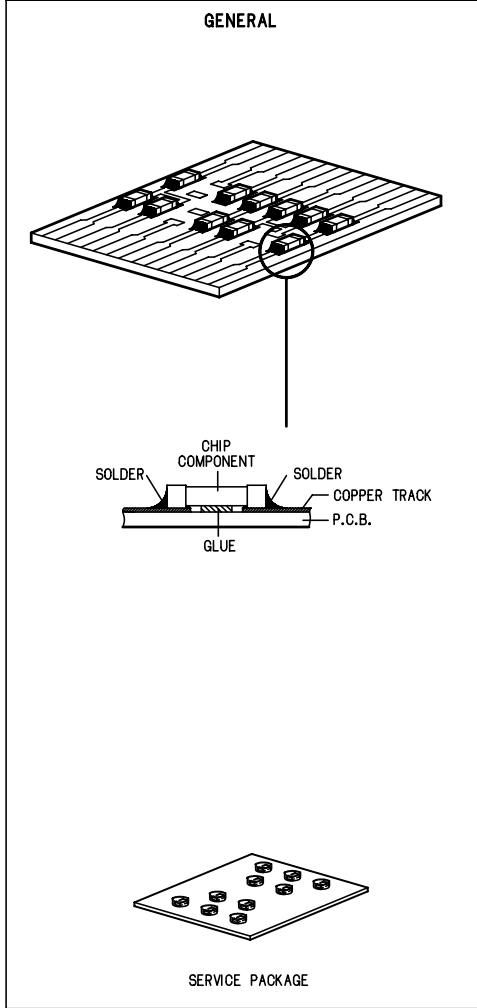

SAFETY GUIDELINES FOR THE PROFESSIONAL SERVICE TECHNICIAN

Important

Proper service and repair is important to the safe, reliable operation of all Philips equipment. The service procedures recommended by Philips and described in this service manual are effective methods of performing service operations. Some of these service operations require the use of tools specially designed for the purpose. The special tools should be used when and as recommended.

It is important to note that this manual contains various CAUTIONS and NOTICES which should be carefully read in order to minimize the risk of personal injury to service personnel. The possibility exists that improper service methods may damage the equipment. It also is important to understand that these CAUTIONS and NOTICES ARE NOT EXHAUSTIVE. Philips could not possibly know, evaluate and advise the service trade of all conceivable ways in which service might be done or of the possible hazardous consequences of each way. Consequently, Philips has not undertaken any such broad evaluation. Accordingly, a servicer who uses a service procedure or tool which is not recommended by Philips must first satisfy himself thoroughly that neither his safety nor the safe operation of the equipment will be jeopardized by the service method selected.

Safety Checks

After the original service problem has been corrected, a complete safety check should be made. Be sure to check over the entire set, not just the areas where you have worked. Some previous servicer may have left an unsafe condition, which could be unknowingly passed on to your customer. Be sure to check all of the following:

Fire and Shock Hazard

1. Be sure all components are positioned in such a way as to avoid the possibility of adjacent component shorts. This is especially important on those units which are transported to and from the service shop.
2. Never release a repaired unit unless all protective devices such as insulators, barriers, covers, strain reliefs, and other hardware have been installed according to the original design.
3. Soldering and wiring must be inspected to locate possible cold solder joints, solder splashes, sharp solder points, frayed leads, pinched leads, or damaged insulation (including the ac cord). Be certain to remove loose solder balls and all other loose foreign particles.
4. Check across-the-line components and other components for physical evidence of damage or deterioration and replace if necessary. Follow original layout, lead length, and dress.
5. No lead or component should touch a resistor rated at 1 watt or more. Lead tension around protruding metal surfaces or edges must be avoided.
6. Critical components having special safety characteristics are identified with a \blacktriangle by the Ref. No. in the parts list and enclosed within a broken line* (where several critical components are grouped in one area) along with the safety symbol \blacktriangle on the schematic diagrams and/or exploded views.
Replacement parts without the same safety characteristics may create shock, fire, or other hazards.
7. When servicing any unit, always use a separate isolation transformer for the chassis. Failure to use a separate isolation transformer may expose you to possible shock hazard, and may cause damage to servicing instruments.
8. Many electronic products use a polarized ac line cord (one wide pin on the plug). Defeating this safety feature may create a potential hazard to the servicer and the user. Extension cords which do not incorporate the polarizing feature should never be used.

Fire and Shock Hazard (Continued)

9. After reassembly of the unit, always perform an ac leakage test or resistance test from the line cord to all exposed metal parts of the cabinet. Also, check all metal control shafts (with knobs removed), antenna terminals, handles, screws, etc. to be sure the unit is safe to operate without danger of electrical shock.

* Broken line: 

Leakage Current Cold Check

1. Unplug the ac line cord and connect a jumper between the two prongs of the plug.
2. Turn on the power switch.
3. Measure the resistance value between the jumpered ac plug and all exposed cabinet parts of the receiver, such as screw heads, antennas, and control shafts. When the exposed metallic part has a return path to the chassis, the reading should be between 1 megohm and 5.2 megohms. When the exposed metal does not have a return path to the chassis, the reading must be infinity. Remove the jumper from the ac line cord.

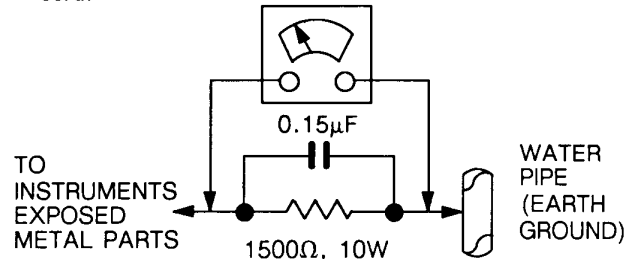

Leakage Current Hot Check

1. Do not use an isolation transformer for this test. Plug the completely reassembled unit directly into the ac outlet.
2. Connect a 1.5k, 10W resistor paralleled by a 0.15µF capacitor between each exposed metallic cabinet part and a good earth ground such as a water pipe, as shown above.
3. Use an ac voltmeter with at least 5000 ohms/volt sensitivity to measure the potential across the resistor.
4. The potential at any point should not exceed 0.75 volts. A leakage current tester may be used to make this test; leakage current must not exceed 0.5 milliamperes. If a measurement is outside of the specified limits, there is a possibility of shock hazard. The receiver should be repaired and rechecked before returning it to the customer.
5. Repeat the above procedure with the ac plug reversed. (Note: An ac adapter is necessary when a polarized plug is used. Do not defeat the polarizing feature of the plug.)

Parts Replacement

1. Many electrical and mechanical parts in Philips equipment have special safety related characteristics. These characteristics are often not evident from visual inspection nor can the protection afforded by them necessarily be obtained by using replacement components rated for higher voltage, wattage, etc. The use of a substitute part which does not have the same safety characteristics as the Philips recommended replacement part shown in this service manual may create shock, fire, or other hazards. Under no circumstances should the original design be modified or altered without written permission from Philips. Philips assumes no liability, express or implied, arising out of any unauthorized modification of design. Servicer assumes all liability.
2. All ICs and many other semiconductor parts are susceptible to electrostatic discharges (ESD). Careless handling during repair can reduce the life of the part drastically.

LASER NOTE:

DANGER - Invisible laser radiation when open. AVOID DIRECT EXPOSURE TO BEAM.

CAUTION - Use of controls or adjustments or performance of procedures other than those specified herein may result in hazardous radiation exposure.

CAUTION - The use of optical instruments with this product will increase eye hazard.

3. Instructions for use

See service manual of concerned modelnumber in which the instructions for use has been inserted. This chapter has not been filled as this module of CDR Module CDL4009 + Mainboard 4228 is only a part of a complete set.

4. Mechanical instructions

4.1 Loader CDL4009

CDL4009 consists of metal loader bracket item 82 and glued on it an identification sticker (on which the module production number and production code is printed); 4 suspension rubbers items 76, 77, 78 and 79 which carry loader assembly item 81;

and on the bottom side the CDR mainboard 1001 is mounted. Notice that mainboard is dependant to the applied set and has to be adjusted to mounted CDM in loader in case of exchange. See next figure, Loader CDL4009

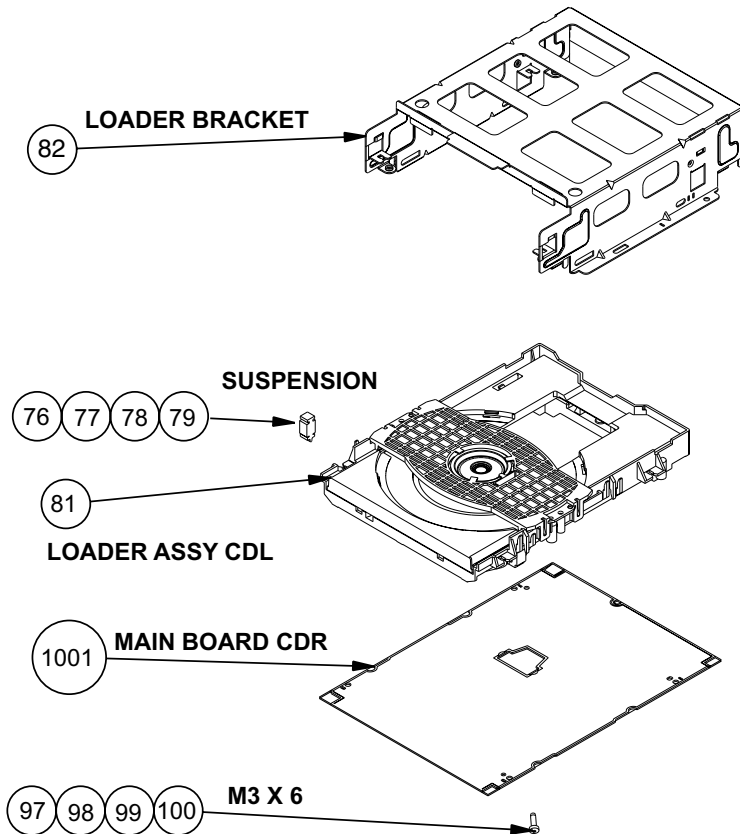

82: LOADER BRACKET
81: LOADER ASSY CDL
76: SUSPENSION

3104 121 23900
9305 043 20900
3104 144 05730

CL06532018_001.eps
090300

Figure 4-1

To demount loader module CDL4009:

1. Mainboard item 1001. Beware of connections to CDM.
Optical pick-up unit has to be ESD protected!
2. Loosen suspensions 76, 77, 78 and 79 from metal loader bracket 81
3. Take out Loader assy CDL

4.2 Exploded view CDL3800

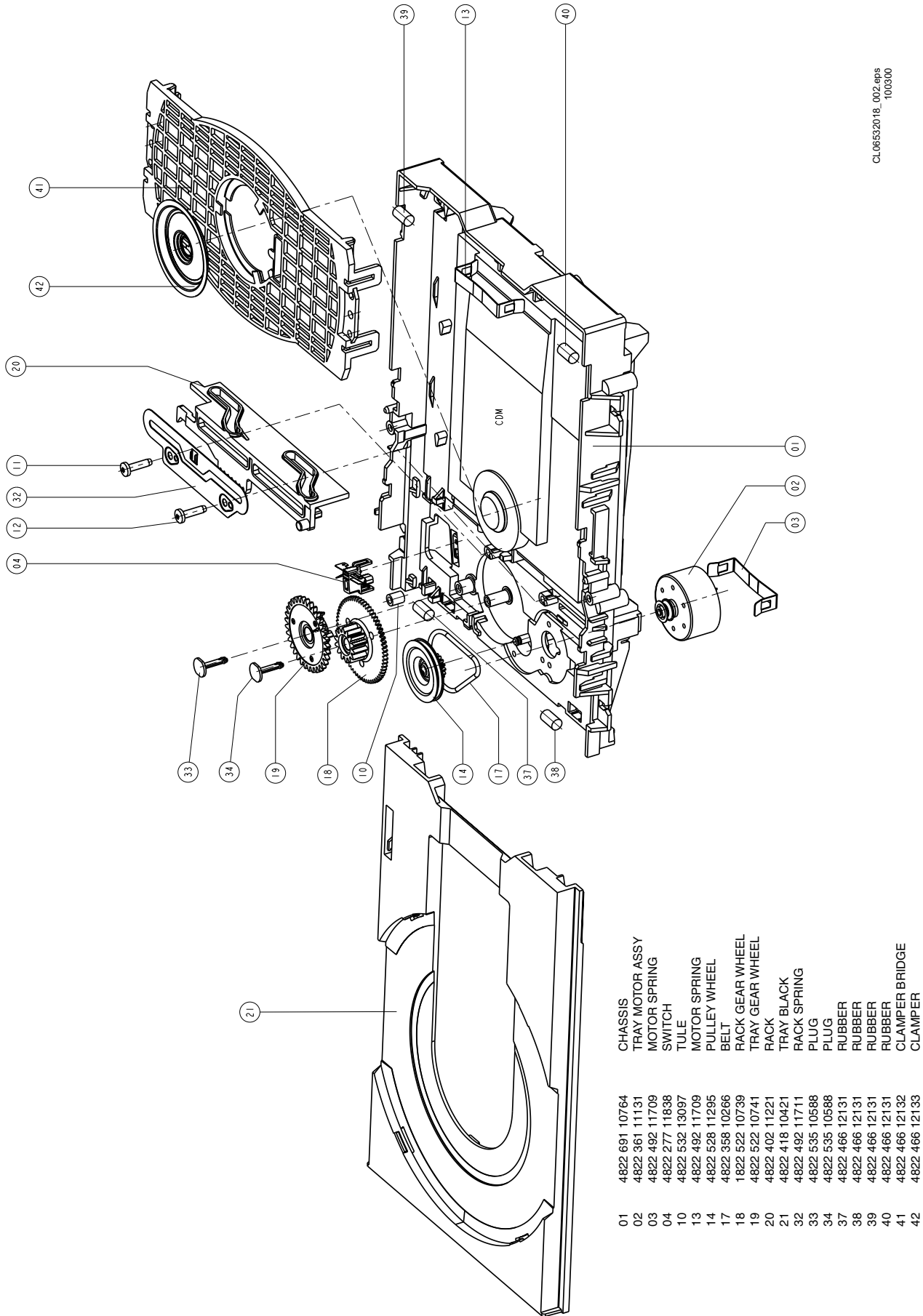

CL06532018_002.eps
 100300

Figure 4-2

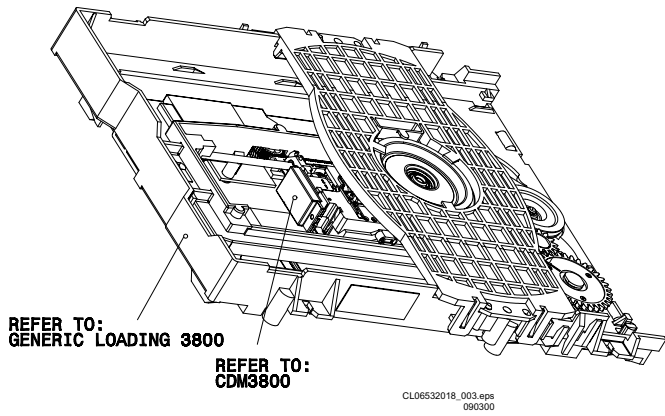

Figure 4-3

4.3 DEMOUNTING LOADER CDL3800

Remove the following items starting with:
 (For the item numbers refer to the Exploded Views CDL3800, figure 4.2)

4.3.1 Release and remove tray

Push to open the tray on the rack (item 20)

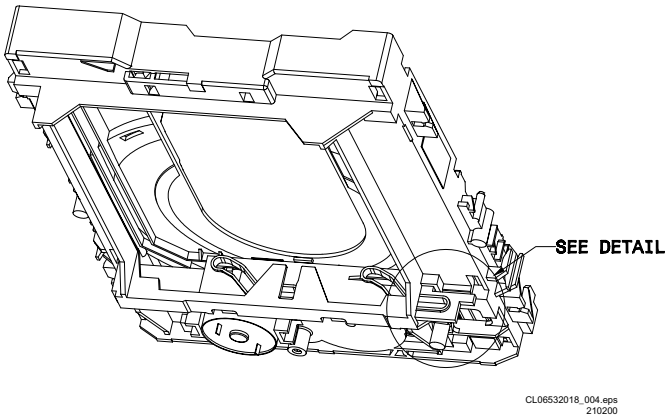

Figure 4-4

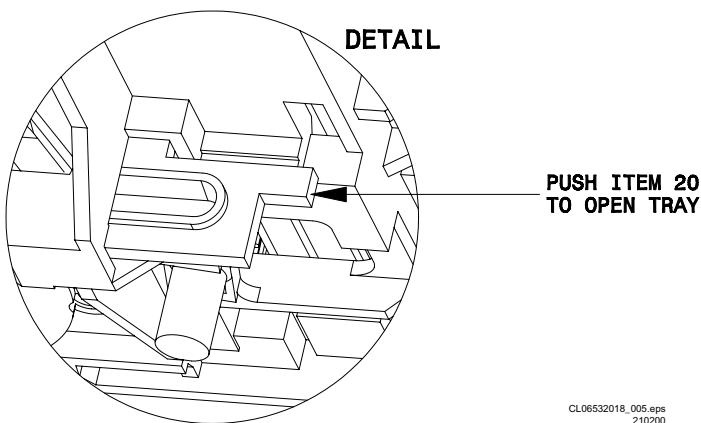

Figure 4-5

Tray

Pull out the tray (item 21) until it sticks. Press the lock at the left side of the tray upwards. Pull out the tray.

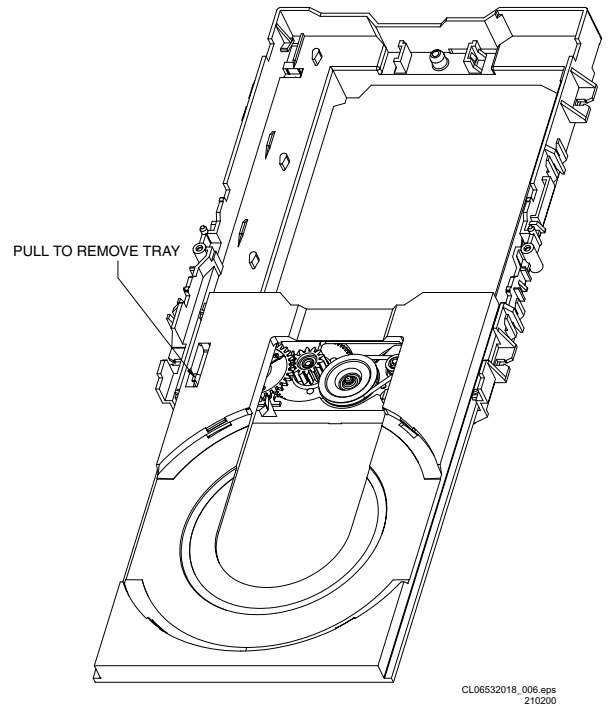

Figure 4-6

Tray motor assey

Remove the tray motor belt (item 17).
 Loosen the motorspring (item 3) with a pair of tweezers or a screwdriver via the rectangular hole at the right side of the tray motor.

Clamper bridge

Bend the locks-profiles on both sides of the clamper bridge (item 41) carefully to the outside and lift up the clamper bridge.

CDM

Place the loader upside down and remove the motorspring (item 13) with a pair of tweezers or a screwdriver, but hold the CDM so it can't fall down.

Rack

First remove the rack spring (item 32) by unscrewing items 11 and 12.

Clamper

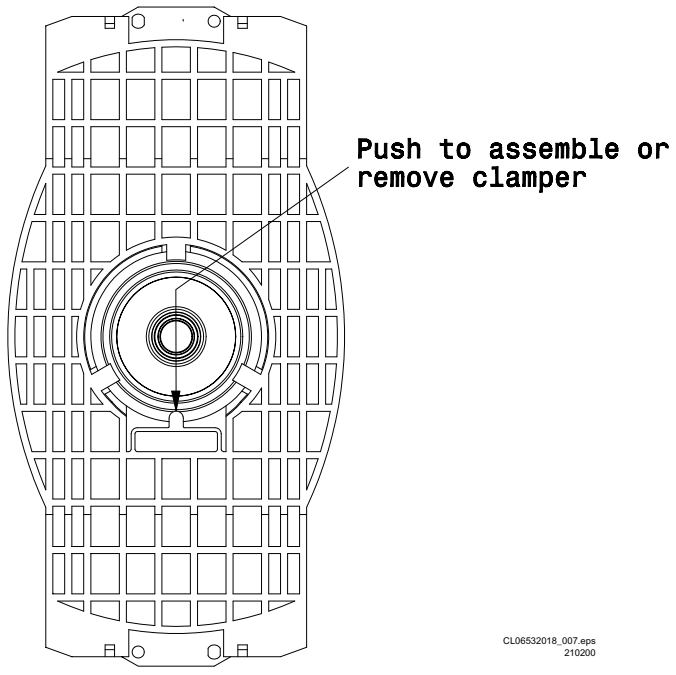

CL06532018_007.eps
210200

Figure 4-7

4.4 Exploded view CDM3800

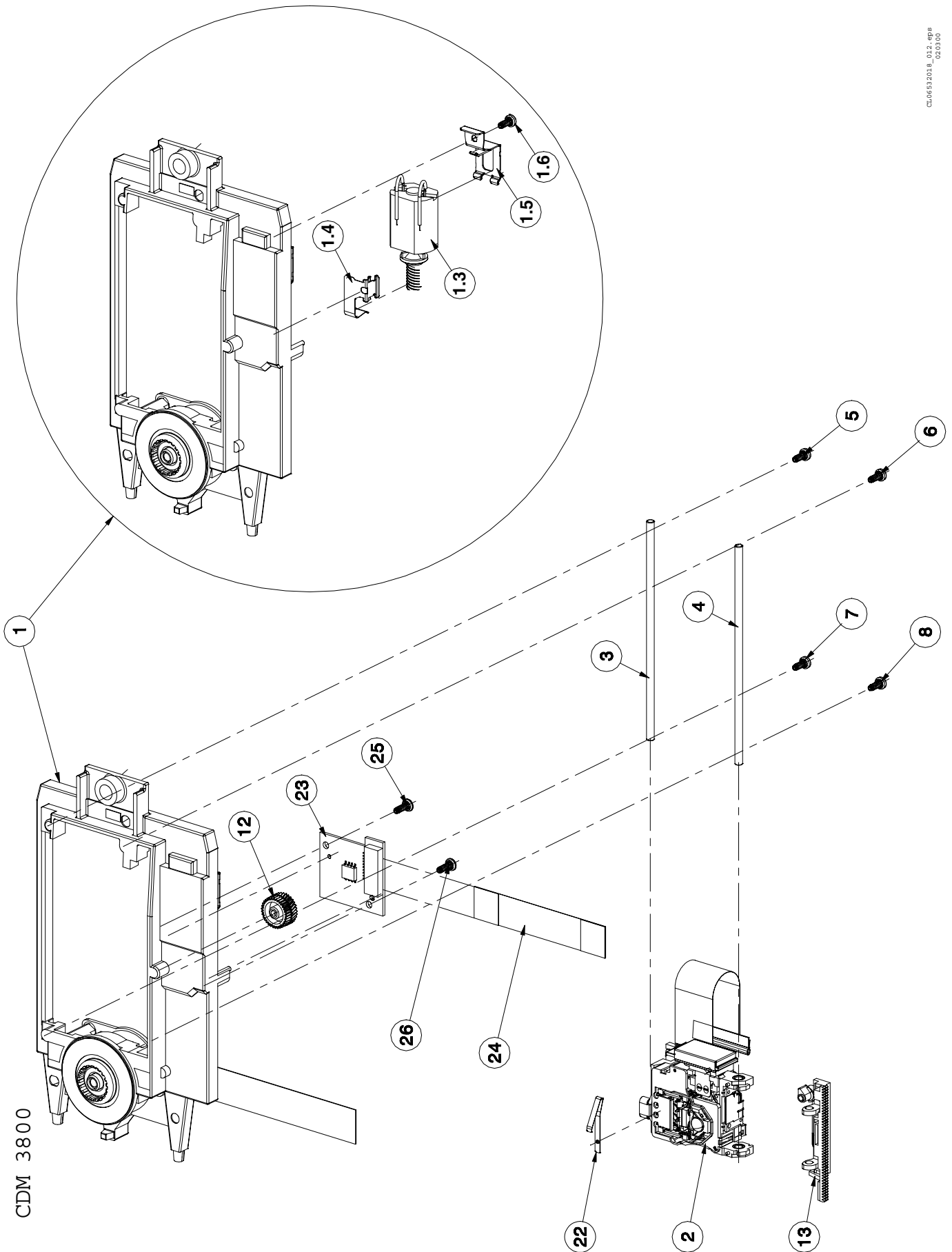

CD06512018_012.dwg
02/03/00

Figure 4-8

3104 147 01580 CDM3800 COMPLETE

- 1: 4822 691 10765 MOUNTING PLATE ASSY
- 1.3: 4822 361 11132 SLEDGE MOTOR ASSY
- 2: 3104 147 12890 OPU-24.24
- 3: 4822 535 10591 THIRD BEARING AXLE
- 4: 4822 535 10591 AXLE
- 12: 4822 528 11297 COMBI WHEEL
- 13: 4822 522 10742 GEAR RACK ASSY
- 22: 3104 141 21830 THIRD BEARING SPRING

2100: 4822 126 13196 100nF 10% 25V
 3100: Δ 4822 051 20101 100 Ω 5% 0,1W
 5101: 4822 130 11531 SENSOR LT125A

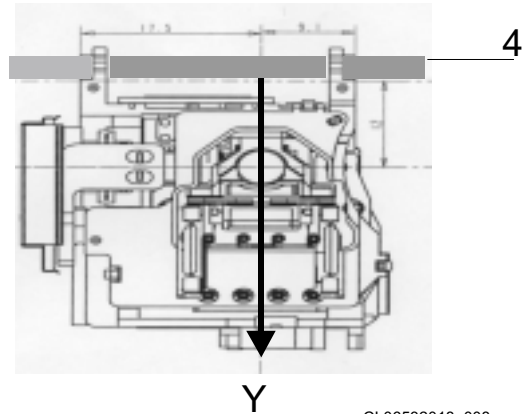

CL06532018_008.eps
210200

4.5 Cleaning objective lens

4.5.1 CLEANING PRESCRIPTION OBJECTIVE LENS

- Cleaning fluid

The lens cleaner codenumber reads 4822 389 10026

- Procedure
 - Take a clean cotton wool tipped stick and put Lens-cleaner on the wool.
 - Wipe the lens very softly with the wet wool end of the stick by moving it forwards and backwards in the Y-direction. (see drawing)
 - Take a dry cotton wool tipped stick and remove the Lens-cleaner from the lens by moving it very softly back and forth in the Y-direction (see drawing)
 - During cleaning, take the necessary precautions in order to prevent damage to the*Actuator (hinges, lens, litze-wires) or OPU (ESD, ...) Do not remove axle (item 4, see drawing) from OPU, because the fixing screws of axle are deforming it at it's end. On their turn these deformings are damaging the hinges of the OPU when loosening the axle.

- Application

This cleaning procedure is only applicable for the flat side (upside) of the lens.

Never try to clean the round side (underside) of the lens (replica-side).

With this cleaning procedure, fingerprints and dust can easily be removed with very soft and gently movements of the cotton wool tipped stick.

- Limitation

This cleaning procedure is only applicable in cases of malfunctions of the product, due to lens-problems. It's not ment to be applied on 100% of the actuators, OPU's.

After cleaning, the product must be re-checked on it's functionality.

Figure 4-9

4.6 Lubricating

4.6.1 LUBRICATING INSTRUCTIONS FOR GENERIC LOADING CDL3800

USE TRIBOL GREASE (1322 523 78101)
 Be careful when lubricating the parts.
 For parts and points to apply grease, refer to the drawing figure 4-10.
 Avoid excess grease.
 B. The bearing of the gearwheel. Grease on upper part of cylindrical surface.^o
 C. Guiding and 2 guiding pins of the rack on the chassis.^o
 D. The guiding of the rackspring.*
 E. The 2 guiding profiles of the rack*
 F. 10 guiding surface of the chassis on the tray.*
 G. The guiding pin on the rack.*
 H. On top (in the middle) of the 4 rubbers.*
 I. Guiding on the chassis of the tray. Grease around the 5 guiding pins.*
 J. The guiding ribs of the chassis for guiding the CDM-nose.*
^o=Lubricated with dosing apparatus.
 *=Lubricated with a brush.

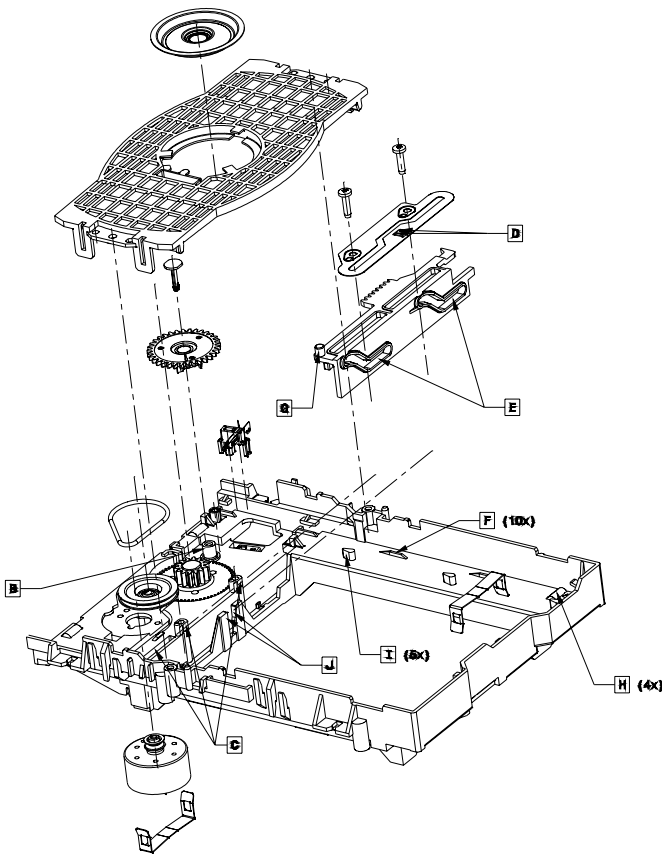

CL06532018_009.eps
210200

Figure 4-10

4.6.2 Lubricating instructions for CDM3800

USE TRIBOL GREASE (1322 523 78101)
 The third bearing axle (item 3, 4822 535 10591) on the upperside of the axle 2x
 The third bearing axle on the bottomside of the axle 2x
 The OPU bearing with Mobil Oil SHC 629 (see next paragraph)
 The top of the worm
 The pressed in axle on the top
 The gear rack assy (item 13, 4822 522 10742) on the teeth 2x

Between worm and combiwheel (item 12, 4822 528 11297)2x

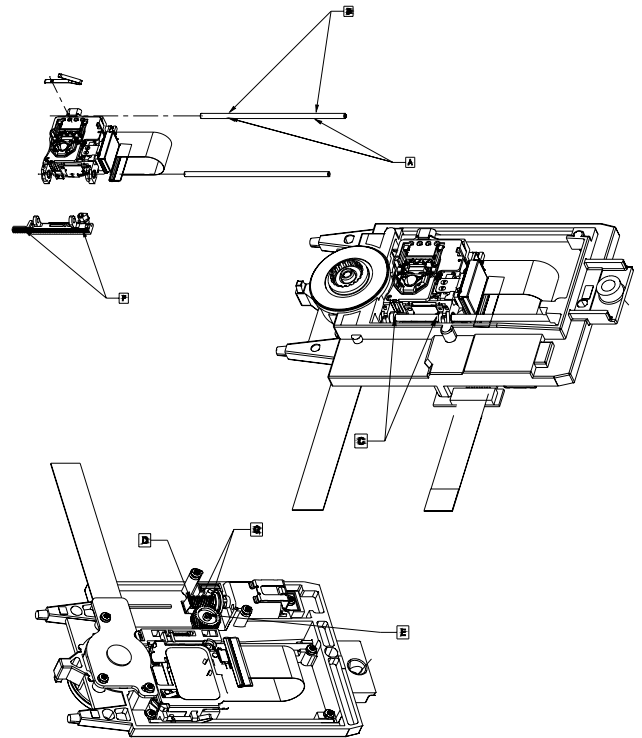

CL06532018_010.eps
020300

Figure 4-11

Oiling the centrifuged bearings

USE MOBIL OIL SHC 629 (3104 129 52260)
 Use dose apparatus
 Place the needle against the bearing and axle.
 Dose one (1) drop of oil there where the bearing touches the axle (see drawing figure 4-12)
 Repeat this handling for the second bearing
 Move the OPU for a few times up and down.
REMARKS:
 Do not use the oil on the axle alone. Always place the oil drop against the bearing.
 No oil on top of the OPU.

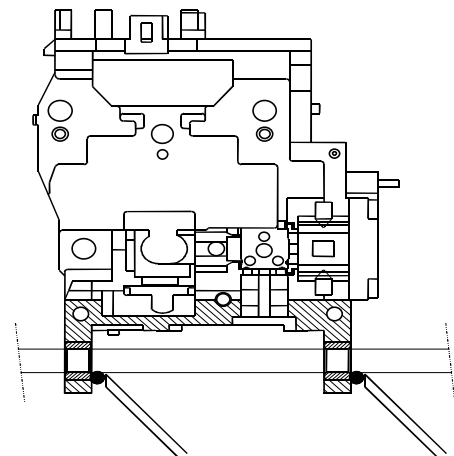

2x 1 DROP OF OIL

CL06532018_011.eps
020300

Figure 4-12

5. Service modes, repair tips and faultfinding trees

5.1 Service modes

In this paragraph the internal selfdiagnostics without opening the set and use of other tools is described.

Notice: Module is mounted in a set

5.1.1 Dealer mode

The purpose of the dealer mode is to prevent people taking out the CD inside the player at exhibitions, showrooms etc.. This mode disables the open/close function of the player. The dealer mode can be switched on and off pressing keys [OPEN/CLOSE] and [STOP] of the CDR player simultaneously while switching on the unit. The dealer mode is stored in the flash memory and can only be changed by executing the above actions.

5.1.2 Dealer diagnostics

display. Pressing keys [F FWD] and [REWIND] simultaneously while switching on the unit, starts the test. Switching off the unit ends the test.

Requirements to perform the test

- Working keyboard to start up the test.
- Working local display to check the output messages.

DEALER DIAGNOSTICS (status of player)

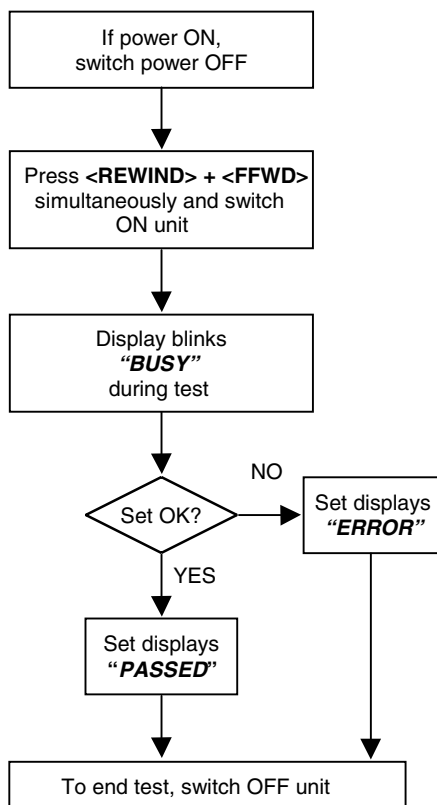

CL96532086-024.eps
090999

Figure 5-1

Description

The intention of the dealer diagnostics is to give an indication of the CDR player status. An inexperienced, even non-technical dealer will/can perform the test. Tests are executed automatically without need for external tools or disassembly of the unit. This test checks the CDR main board using the same tests as the electrical service diagnostics program. Only the result of the test, "PASSED" or "ERROR", will be shown on the

5.1.3 Electrical service diagnostics

ELECTRICAL SERVICE DIAGNOSTICS
(software versions, test for defective components)

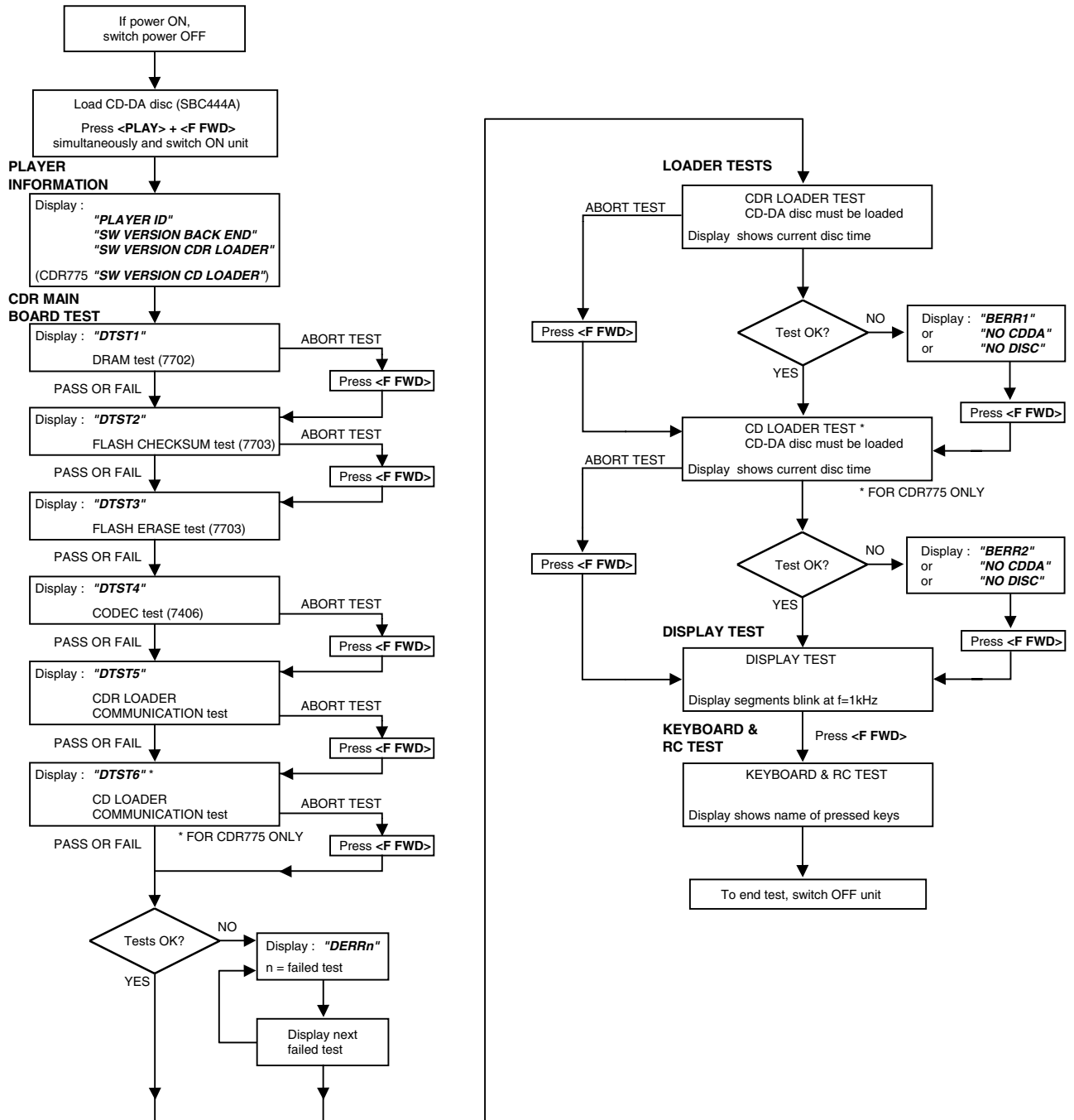

Figure 5-2

Description

The intention of the electrical service diagnostics is to show the software versions present in the player and to direct the dealer towards defective internal units. The units are : the CDR main board, the CDR loader, the CD loader in case of a CDR775 and the keyboard/display board. A sequence of tests is executed automatically. Some of the tests can be aborted or skipped without the result being taken into account. External tools or disassembly of the unit is not necessary to get the diagnostic information. Pressing keys [PLAY/PAUSE] and [F FWD] simultaneously while switching on the unit, starts the test. Switching off the unit ends the test.

Requirements to perform the test

- Working keyboard to start up the test.
- Working local display to check the output messages.
- A CD-DA disc with a minimum of 3 tracks in all trays to perform the disc test.

Description of the tests**Player information**

In this part of the test the following important information can be checked without removing the cover :

- Recorder ID.
- SW-version back end of player.
- SW-version CDR loader.
- SW-version CD loader (only for CDR775).

CDR main board test

[F FWD] key. The message "DERRn" will be displayed with n indicating the faulty test number.

If one of the tests is aborted with the [F FWD] key, no error message will be displayed for this test. The flash data erase test ("DTST3") can not be aborted !

The CDR main board test consists out of :

DRAM test

Display : "DTST1". The DRAM used for buffer management is tested by writing, reading and verifying test patterns.

Flash checksum test

Display : "DTST2". This test checks the checksum of the player's SW stored in the flash.

Flash data erase

Display : "DTST3". During this test, all temporary information (CDtxt) in the flash is erased.

CODEC (ADC/DAC) test

Display : "DTST4". This test checks the CODEC IC by writing, reading and verifying test patterns. The test is not applicable for CDR950.

CDR communication test

Display : "DTST5". The communication between the host processor (DASP) and the CDR loader via the DSA-R-bus is tested.

CD communication test

Display : "DTST6"). The communication between the host processor (DASP) and the CD loader is tested. The test is only applicable for CDR775.

Loader tests

These tests determine if the CDR loader and the CD loader in case of a CDR775 work correctly. A CD-DA disc with a minimum of 3 tracks needs to be inserted in both loaders. A disc test is executed to check focus control, disc motor control, radial control and jump grooves control. The disc test is

performed by audio play-back of 5 seconds at the beginning, middle and end of the disc.

CDR loader test

During the test, the current disc time is shown. In case of an error the message "BERR1" will be displayed and the [F FWD] key must be pressed to continue with the following test. Pressing the [F FWD] key also aborts this test.

CD loader test

For CDR775 only. During the test, the current disc time is shown. In case of an error the message "BERR2" will be displayed and the [F FWD] key must be pressed to continue with the following test. Pressing the [F FWD] key also aborts this test.

Display test

All segments will blink at a frequency of 1 Hz. Pressing the [F FWD] key will start the next test because the user has to check for himself if all segments work properly.

Keyboard and remote control tests

The test will give the user the ability to test every key without executing the function assigned to it. Therefore, the user needs to press every key on the keyboard and the remote control. The display will show the name of the key being pressed. Pressing more than one key at once will give an unpredictable result except for the service combinations : [PLAY/PAUSE] + [STOP], [PLAY/PAUSE] + [F FWD], [F FWD] + [REWIND], [ERASE] + [RECORD], [PLAY/PAUSE] + [RECORD], [OPEN/CLOSE] + [PROGRAM].

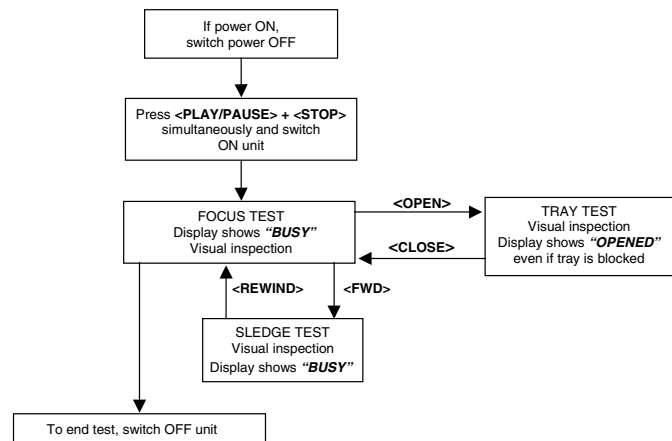
5.1.4 Mechanical service diagnostics**MECHANICAL SERVICE DIAGNOSTICS**
(test for defective components)CL96532086_026.eps
080999**Figure 5-3****Description**

No external tools are required to perform this test. The cover needs to be removed because the user has to check the movements of the tray, focus and sledge visually. Pressing keys [PLAY/PAUSE] and [STOP] simultaneously while switching on the unit, starts the test. Switching off the unit ends the test. In case of a CDR775, one can check the CD loader mechanics in the same way by pressing the above key combination on the CD player keys.

Requirements to perform the test

- Working keyboard to cycle through the tests and to start up the test.
- Working local display to check the output messages.

Description of the tests

Focus control test

The focussing lens is continuously moving up and down. The display reads "BUSY".

Sledge control test

After pressing [F FWD] the sledge continuously moves up and down. Pressing [REWIND] stops the sledge at the position it is in and the focus control test resumes. The display reads "BUSY".

Tray control test

This test starts from within the focus control test routine. Pressing [OPEN/CLOSE] moves the tray in or out. In the tray open position one can initiate focus and sledge tests by pressing [F FWD]. One has to stop these tests pressing [REWIND] before it is possible to close the tray again. Depending on the action the display reads "OPEN", "OPENED", "CLOSE" or "BUSY".

5.1.5 DC-erase service mode

DC ERASE SERVICE MODE
(erasure of complete CD-RW)

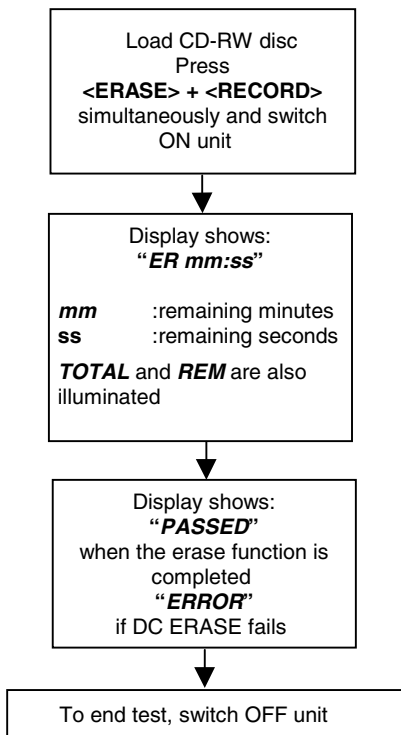

Figure 5-4

Description

This test is initiated by pressing [ERASE] and [RECORD] simultaneously while switching on the unit. The player will erase a complete CD-RW disc (including PMA and ATIP lead out area) at speed N=2. The display shows the countdown of the remaining time required for the operation to complete. The format is "ER mm:ss", where "mm" are the remaining minutes and "ss" the remaining seconds. After completion the message "PASSED" is shown, and the player has to be switched off and on again to start up in normal operating mode. Switching off the

unit before completion of the test, leaves the disc in an unpredictable state. In such case only a complete DC-erase procedure can recover the CD-RW disc.

Requirements to perform the test

- Functional CDR player.
- A CD-RW audio disc must be present in the tray.

5.1.6 Burn in mode

Description:

The Burn In mode is an endless cycle of:

- DC-Erase to erase the CDRW disc with maximum laser power.
- Recording a CDRW disc
- Finalising at double speed

The Burn In mode is used to test intermittent faults of the loader.

Requirements to perform the test:

- Working Local Keyboard: needed to start up the test.
- Working Local Display: all output messages must be displayed on the local display.
- Analog source connected to the CDR99 player
- CDRW disc in tray

Burn in sequence

– Initialisation

The 'Burn In' mode is initiated by pressing the PAUSE> and key on the local keyboard at the same time, and then switching the POWER switch on.

– Continuous loop

The following picture shows the burn in sequence.

Burn in sequence

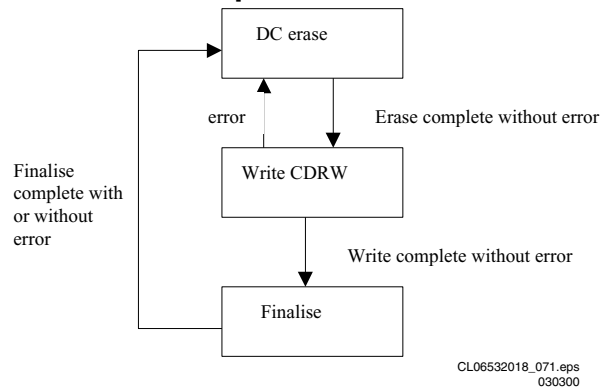

Figure 5-5

Continuously do DC erase, record complete CDRW and then finalise until the player is powered off.

When an error is detected during writing, the DC erase procedure is called again., the disc will be DC erased and the cycle starts again.

During the test the display shows the number of hours for which the test is running and the number of errors detected during the test. The display looks as follows : "HH BI RE FE"

- HH : number of hours on digits 1 and 2
- "BI" : burn in mode, digits 3 and 4
- RE : number of errors detected during DC erase and write CDRW modes on digits 7 and 8

FE : number of errors detected during finalise modes on digits 10 and 11

If started up with a disc other than a CDRW disc the display shows : "WRONG DISC", if no disc is inserted display : "NO DISC".

– End of test
To exit the Burn In mode, power off the player.

5.2 Faultfinding Trees

The faultfinding trees and repair suggestions like the power supply voltages for proper functioning of the mainboard are indicated here.

5.2.1 CDR-Module

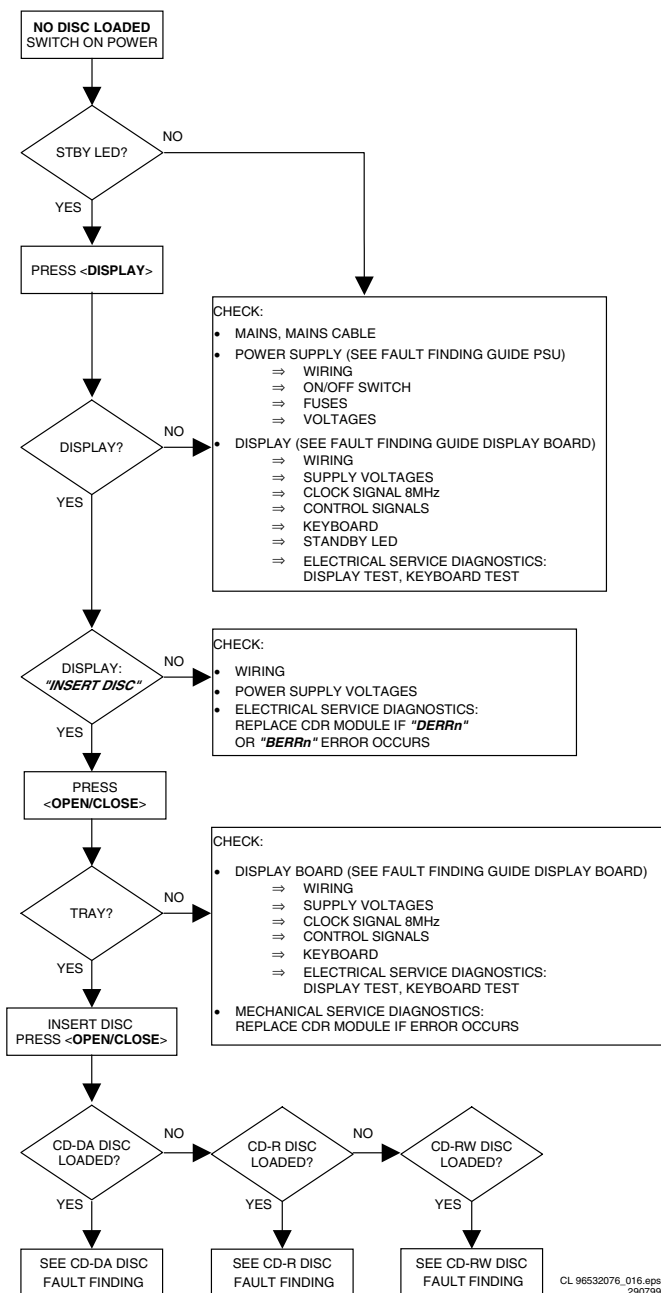

CL 96532076_016.eps 290799

Figure 5-6

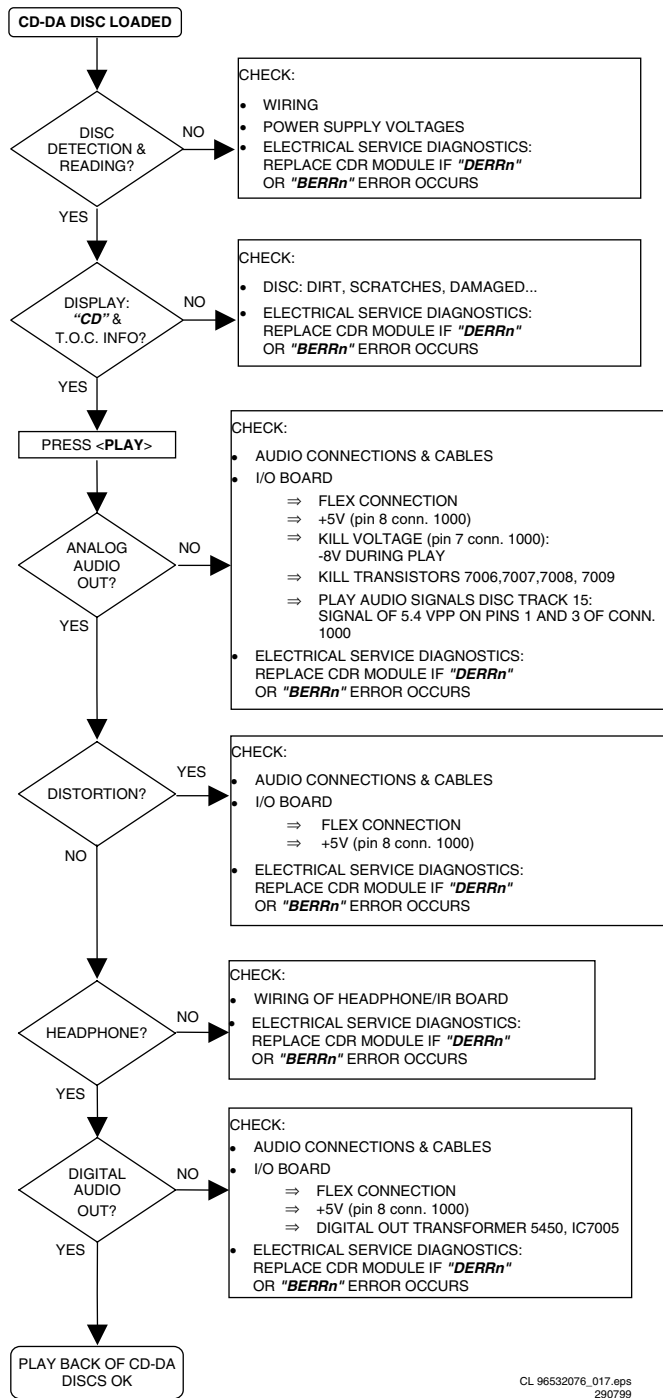

CL 96532076_017.eps 290799

Figure 5-7

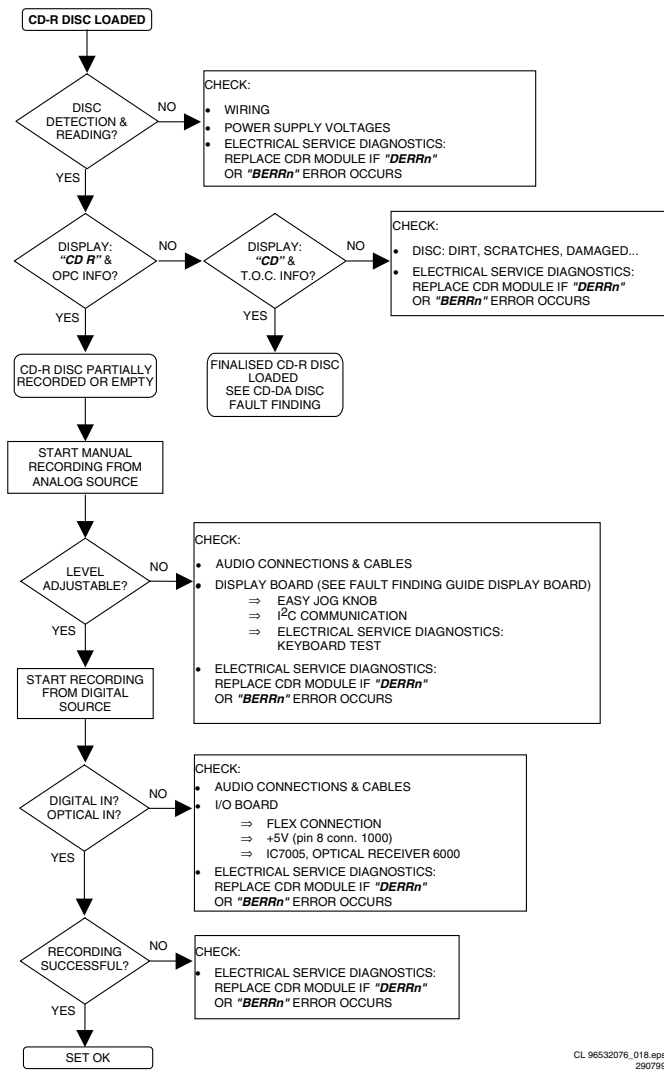

Figure 5-8

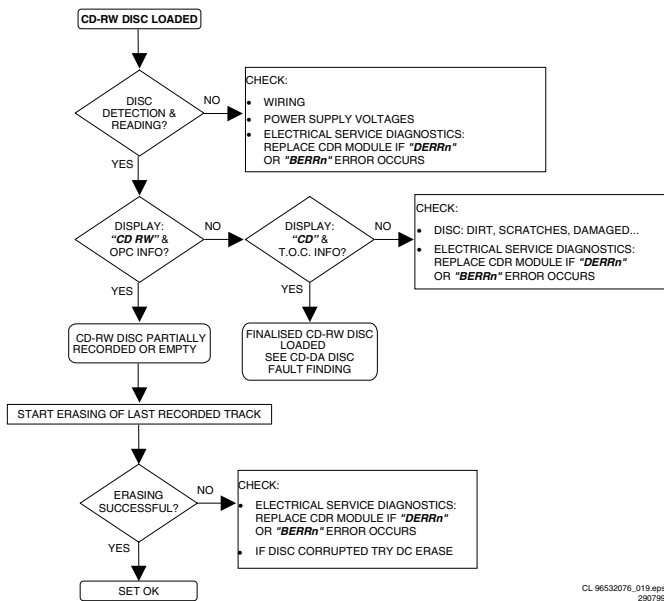

Figure 5-9

5.2.2 Mainboard

Power supply part on mainboard

- Description.

The most important part of an electrical function is the power supply. Without it will never operate. The power supplies as well analog as digital equipment. For these reasons the power supply is split-up in different sections. One for the digital electronics, one for the servo controls and one for the AUDIO part. The servo controls are the big consuming parts with high peak-currents, also introducing disturbances in the power lines. The audio part needs very "clean" power, because noise and ripples have there reflection in the audio signals, specially in S/N and THD+N. Some of the power supplies are switched off, this to reduce consumption in case of standby.

The different power supplies are delivered to the PCB via connector 1500 This is a 11 pole connector with following voltages on it: +5V, +12V, -8V, VFTD, VDC1 and VDC2. The last 3 voltages are not used on the main PCB, but are meant for the FTD (Fluorescent Tube Display). They are directly routed to connector 1705.

The other voltages are split up in different functions on the PCB. The following block-diagram gives an indication of that implementation.

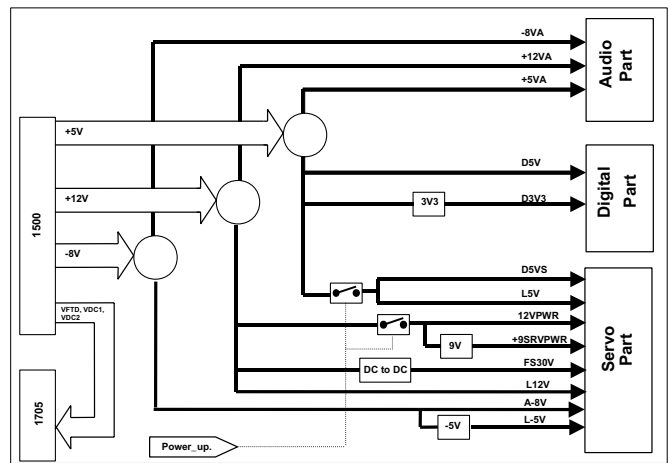

Figure 5-10

- Power supply to main board.

Power supply enters the BOARD via connector 1500. Pinning as follows:

- Connector 1500
- pin 1: VDC2 : 3V8 (10%)
 - pin 2: VFTD : -38V (5%)
 - pin 3: VDC1 : 3V8 (10%)
 - pin 4: GND : Ground.
 - pin 5: D5V : +5V (5%)
 - pin 6: D5V : +5V (5%)
 - pin 7: GND : Ground.
 - pin 8: GND : Ground.
 - pin 9: GND : Ground.
 - pin 10: 12V : 12V (10%)
 - pin 11: -8V : -8V (10%)

POWER PART CHECK

USE CDR MAIN BOARD CIRCUIT DIAGRAM 7 AND CDR MAIN BOARD BOTTOM VIEW : POWER PART TEST POINTS

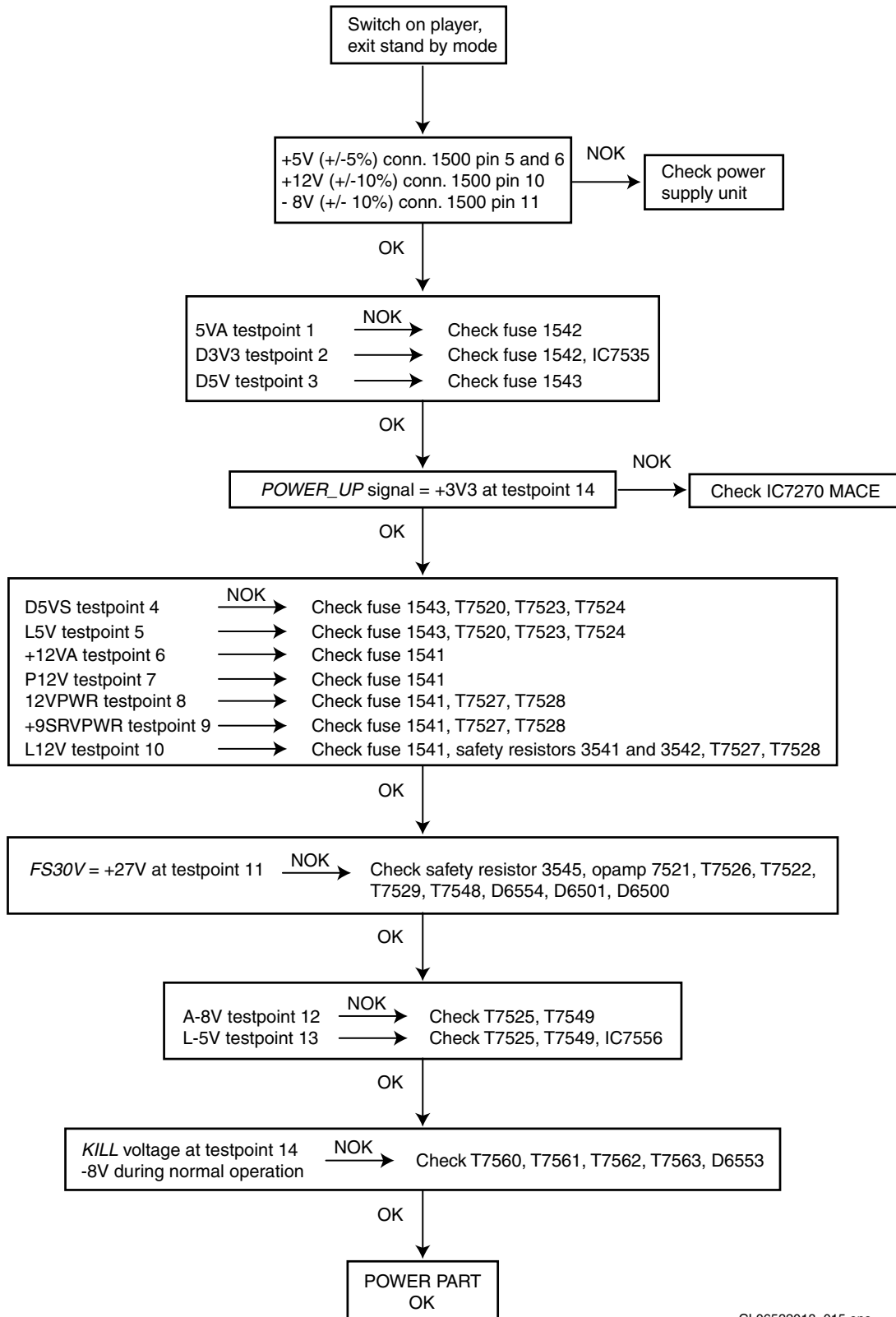

Figure 5-11

Reset & Clock

Master reset.

Since the Mainboard is more or less mix-mode between +3V3 and +5V devices, special treatment for the RESET behavior is wishful. Controlling the RESET only from 1 power supply could lead to collisions between different devices, damaging the internal I/O structure of the devices. To avoid this the +3V3 and the +5V are guarded by a special device. These devices keep the output low as long as the power supply is not stable or is not above the required level. As soon as the power supply is stable it switches the output to "HIGH-Z". The output is an open collector type. From then onwards the line can be controlled by means of external pull-up resistors. Benefit of the open-collector devices is that several of those devices can be tight together at the outputs. In our case we used a device on the +5V and one on the +3V3. This means that both power supplies need to be stable before the RESET of the Master processor is released.

Resetting several processors in the same structure by means of the power supplies invokes certain risks. The duration of initialization after reset is processor and Code depending. It can lead to hang-up in those cases that communication between the processors is "time" driven. Meaning that only in a certain time frame the establishment of the communication-bus must take place. If not successful the Bus hangs!

To avoid these kinds of problems, only 1 RESET is depending on the power supply, and this is the RESET of the Master controller. The same master controller will then take care of the RESET of the other devices. In the next figure this is explained.

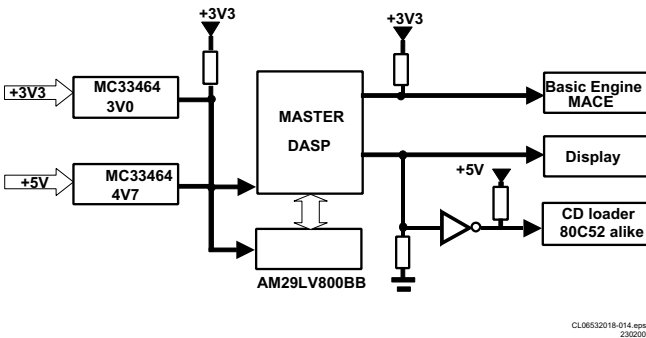

CL06532018-014 app
230200

Figure 5-12

For further measurements see next reset and clock flowcharts.

RESET & CLOCK CHECK

USE CDR MAIN BOARD CIRCUIT DIAGRAMS 4, 9 AND 10 AND CDR MAIN BOARD BOTTOM VIEW : RESET & CLOCK TESTPOINTS

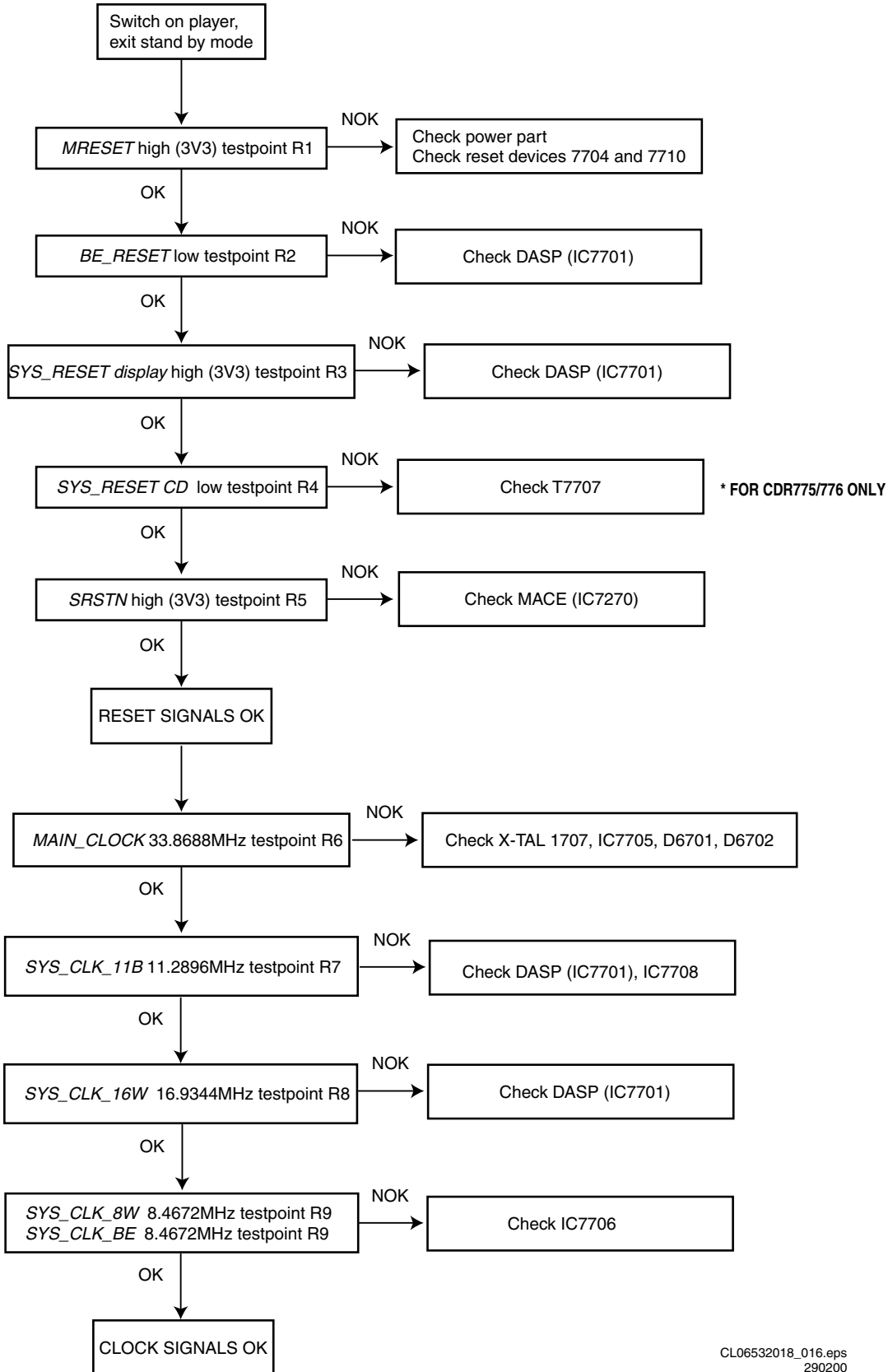

Figure 5-13

The clockgeneration

All microprocessors or digital devices need a clock. The clock is usually made by means of resonators or crystals depending on the speed and the accuracy that is requested. The clock can also differ from device to device so that more than one crystal is needed. The cheapest and "system wise" best way is only 1 crystal. The derived clocks are then Phase related to each other.

On the CDR MAIN 99 the DASP is generating all clock signals. Not only the systemclock for the processor itself, but also for the basic engine processor and even the systemclock for the ADDA part which is directly related to the 44.1kHz. sample frequency. To be able to do this a 33.8688Mhz. crystal with 25ppm accuracy is connected to the internal oscillator of the DASP. Internal the clock signal is multiplied by means of a PLL. This gives the systemclock on which the processor runs internally. This systemclock is then again divided internally to have the systemclock for the ADDA, which is 11.2896Mhz, and the 16.9344Mhz. which divided by 2 gives the systemclock for the BE part. In this way only 1 crystal is required. The same 8.4672Mhz. is also routed to the CD-module in case of a CDR775 player.

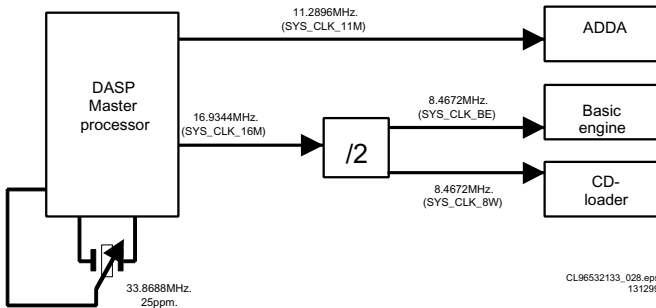

Figure 5-14

PC help on mainboard diagnostics

A couple of the diagnostics are only possible with the help of a PC. The DASP micro controller will contain an interface with the external world; this interface is realised via a serial RS232 connector that is accesible inside the player. It can be accessed from the outside world by means of test pins and connector 1818 and interface board 7104 086 91111.

Via those test pins a terminal emulator can be connected. Then menus will come up that give the opportunity to enter all Audio Engine commands. This includes the commands on Bit Engine Level (transparent). This terminal emulator functionality is part of the embedded software, so no external software is needed. It can also read out the User Profile Logging of Bit Engine. This can show the hours that the loader really was in recording mode.

This diagnostic tool is activated if communication is detected on the RS232 interface during power up. The baud rate for both is 19k2 baud.

Details of the diagnostic tool are given in chapter 5.2.3 of this publication: Menu Driven Diagnostics.

Also in preparation is the interactive COMPAIR tool. Then the PC communicates in an active form with the set and compares the result for making the next decision. With MDD the technician has to take the next active step from his experiences onwards.

5.2.3 Menu Driven Diagnostics

In this paragraph the specification of the software requirements for the Menu Driven Fault Finding Diagnostics is given. It will give a clear and unambiguous description of what the Menu Driven Diagnostics (MDD) do.

NOTICE: THE TESTS, AS PROVIDED BY THE MENU DRIVEN DIAGNOSTICS, ARE NOT SUPPOSED TO BE MIXED RANDOMLY, ESPECIALLY TESTS LIKE 'LASER ON' AND 'FOCUS ON'. IT IS ASSUMED THAT THE PERSON THAT USES THE MDD KNOWS IN WHICH ORDER THESE TESTS CAN BE EXECUTED.

The MDD module communicates with two entities: the terminal emulator on the PC. The MDD receives instructions (test to be executed) and transmits the menu to be shown and the test results; the Audio Engine module. It instructs the Audio Engine via the interface field which test should be executed. The test result is retrieved from the interface field.

Requirements

The functionality of the Menu Driven Diagnostics module is to implement Menu Driven Diagnostics for service purposes. When the CDR recorder is connected to a PC via an interface board 7104 086 91111, connection cable 3104 157 11122 and a RS232 cable (available at PC shop), the service technician can select via a menu on the PC screen which test should be performed. The result of the test is also shown on the PC screen. No special test tool is needed for the PC; any terminal emulation program can be used (for example, HyperTerminal under Windows95/NT).

The last occurred error during a test session can be retrieved via the menu.

The RS232 connector should be soldered to pins:

1818-1 = Rx

1818-4 = Gnd

1818-2 = Tx

General Constraints

It is advised to connect the connection cable 3104 157 11122 to the Mainboard connector 1818 mounted just under the loader (topview). Via this cable also the powersupply for the interface board 7104 086 91111 is arranged when it is connected to connector 1000 on interfaceboard. To start this application at powering on; for 5 seconds the Rx and Tx output pin of the mainboard connector should be short circuited. This temporarily short circuit indicates the internal CDR software program to switch onto Menu Driven Diagnostics. This short cut can easily be done via the switch (1009) on the interface board. To communicate with the PC the RS232 cable has to be connected to output connector 1010 on the interface board and the switch (1009) should be released.

When switching on the CDR, two possibilities exist: the RS232 cable is not connected. The application is executed (no MDD mode); the RS232 connector is connected; Rx and Tx are short circuited for more than 5 seconds then the Menu Driven Diagnostics is started. By connecting via connection cable to interface and from there via the RS232 cable onto the PC, so the MDD can transmit the main menu to the PC.

User Interfaces

RS232 interface

The CDR recorder transmits the menu to be shown and the test results to the PC via connection cable 3104 157 11122, interface board 7104 086 91111 and a RS232 cable. It receives the selection of the user, chosen in the menu.

Hardware Interfaces

RS232 interface

The communication via RS232 should be set to the following settings:

Baudrate:19200

Databits:8

Stopbits1

Parity:none

Handshaking:none

Data Communication Interfaces

Communication between the CDR recorder and the PC is straightforward: everything the CDR recorder transmits to the PC is shown on the PC screen. Data, transmitted from the PC to the CDR775, is treated as a choice from the currently shown menu.

All functionality of the MDD has to be part of the CDR775 software; the PC can only use a terminal emulation program.

Menu Structure and Test Results

This chapter describes the structure of the menus and the results of the tests, as shown on the PC screen.

Menu Structure

When starting up, the PC screen is cleared and the software version and the main menu (level 1) are shown. From the main menu, one of the sub menus (level 2) can be selected. These sub menus contain other sub menus and/or a number of tests that can be executed. The menus are shown below. '>>' indicates that when this option is selected, a new menu will be shown.

Level 1 Mainmenu:

MAIN MENU
 1 General tests >>
 2 Retrieve last occurred error
 3 Recorder module test >>
 4 Playback module test >>* *Only used for the CDR775
 5 Select adjust program CDM
 6 Download new program

When a test is running, a 'test running indicator' (a dot) is showed on the screen every second, When a test has been executed, the screen is cleared and the result of the test (if any) and the menu, separated by one empty line, are showed.

Three types of tests exist:

Tests that return PASSED or FAILED, like the DRAM test.

When a test has been executed, the result is showed on the PC screen;

Tests that return a value, the message 'PASSED, xxx' (with xxx is the returned value) is showed on the PC screen;

Tests that don't return anything, like the 'laser on' test. Most of these tests require a visual check of the service person. When one of these tests is executed, 'PASSED, visual check' is showed on the PC.

Level 2 menus

When a submenu is selected in the main menu, the level 2 menus are showed . These sub menus contain other sub menus and/or a number of tests that can be executed.

GENERAL TESTS MENU

1 Check DRAM
 2 CHECK FLASH>>
 3 Check ADC/DAC
 4 Check LCD

RECORDER MODULE TEST MENU

1 communication test
 2 Tray >>
 3 Laser >>
 4 Focus >>
 5 Radial >>
 6 Sledge >>
 7 Miscellaneous >>
 8 Jump grooves >>

PLAYBACK MODULE TEST MENU

1 communication test
 2 Tray >>
 3 Laser >>
 4 Focus >>

5 Turntable motor >>
 6 Radial >>
 7 Sledge >>
 8 Miscellaneous >>

Level 3 menus

CHECK FLASH MENU
 1 Check FLASH
 2 Manufacturer-ID and
 3 Device ID

TRAY MENU

1 Open tray
 2 Close tray

LASER MENU

1 Laser off
 2 Laser on, read
 3 Laser on, write*-----*Laser on, write' only used for the recorder module

FOCUS MENU

1 Focus on
 2 Focus off

TURNTABLE MOTOR

1 Turntable motor ON
 2 Turntable motor OFF

RADIAL MENU

1 Radial control on
 2 Radial control off

SLEDGE MENU

1 Sledge inwards
 2 Sledge outwards*-----*Sledge stays outwards for the recorder module; sledge moves inwards after 300 ms for playback module

JUMP GROOVES MENU

1 Jump grooves to inside
 2 Jump grooves to middle
 3 Jump grooves to outside

MISCELLANEOUS MENU

1 Start player
 2 Stop player
 3 Calibrate CD >>*-----*Only used for recorder module
 4 Get user profile logging
 5 Erase CD-RW*-----*Only used for recorder module
 6 Read firmware version**-----**CD firmware version for CD-module, CDR firmware version for CDR-module

CALIBRATE CD MENU *-----*Only used for recorder module

1 Calibrate CD, N=1
 2 Calibrate CD, N=2
 3 Get last OPC values

End of test

These diagnostics can be quitted by powering off the player

5.2.4 Servo drivers check

SERVO DRIVERS CHECK

USE CDR MAIN BOARD CIRCUIT DIAGRAMS 1, 3 AND 4 AND CDR MAIN BOARD BOTTOM VIEW : SERVO DRIVERS TESTPOINTS

FOCUS SERVO

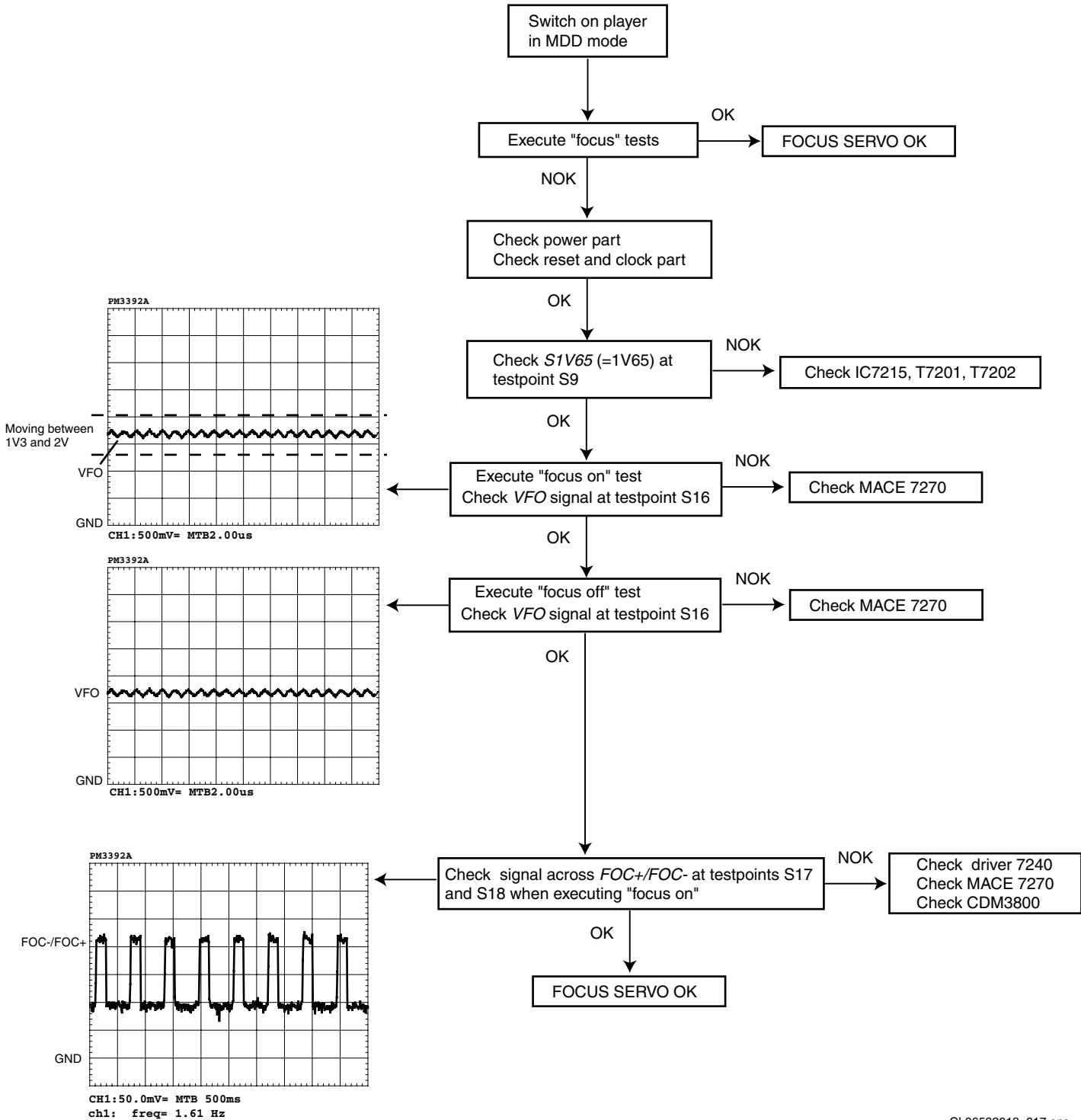

Figure 5-15

SERVO DRIVERS CHECK

USE CDR MAIN BOARD CIRCUIT DIAGRAMS 1, 3 AND 4 AND CDR MAIN BOARD BOTTOM VIEW : SERVO DRIVERS TESTPOINTS

RADIAL SERVO

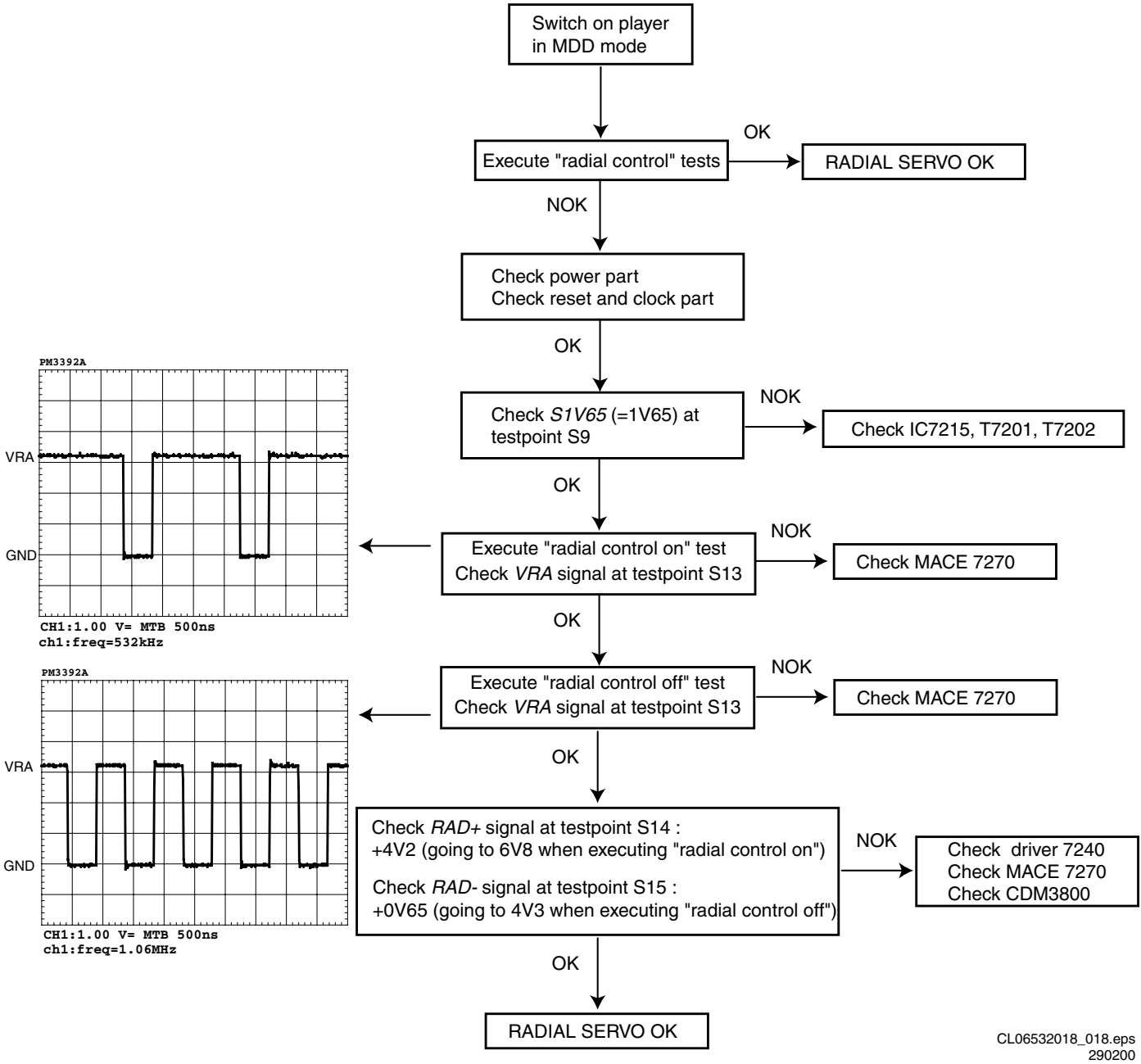

Figure 5-16

SERVO DRIVERS CHECK

USE CDR MAIN BOARD CIRCUIT DIAGRAMS 3 AND 4 AND CDR MAIN BOARD BOTTOM VIEW : SERVO DRIVERS TESTPOINTS

SLEDGE SERVO

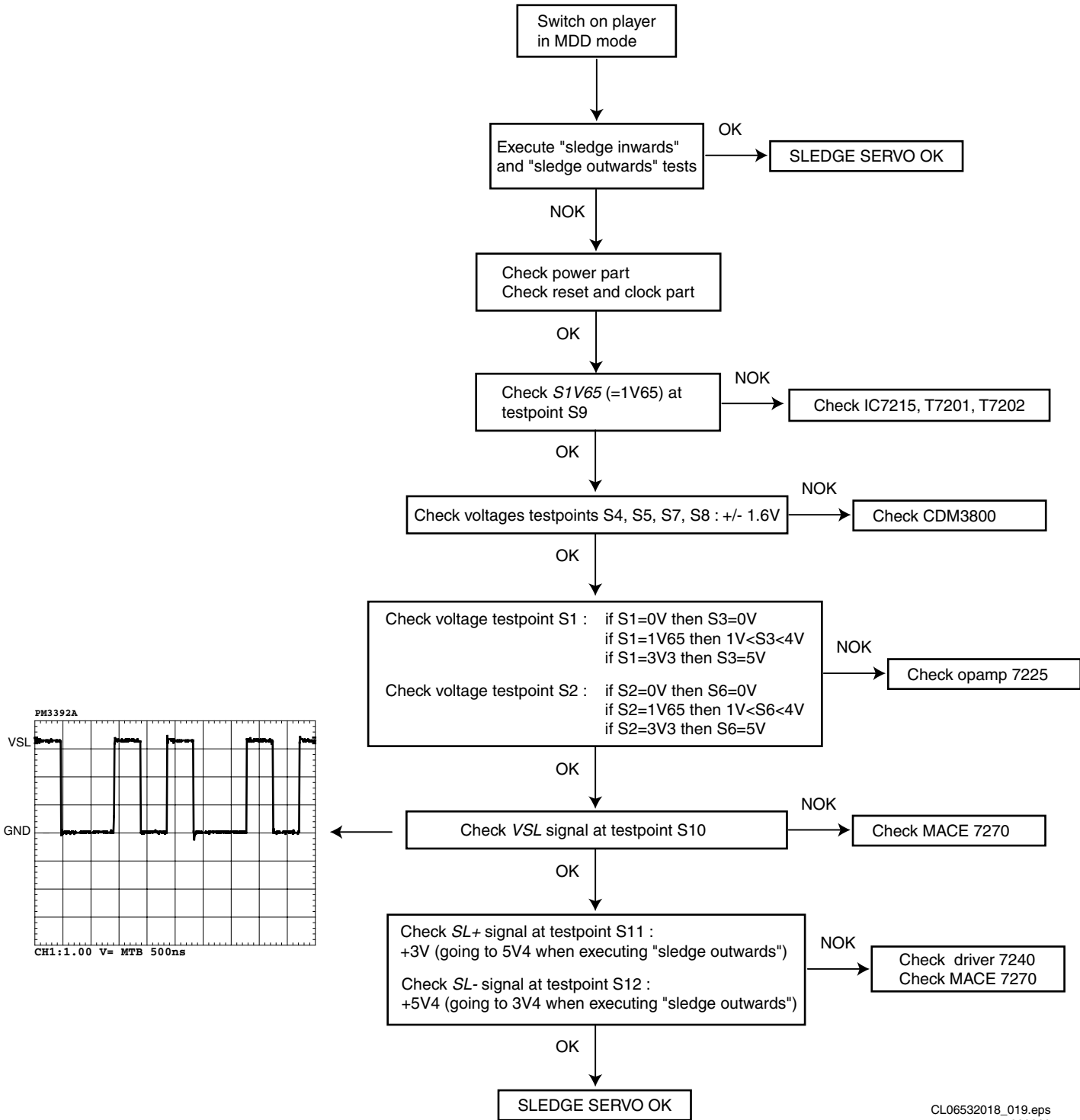

Figure 5-17

SERVO DRIVERS CHECK

USE CDR MAIN BOARD CIRCUIT DIAGRAMS 3 AND 4 AND CDR MAIN BOARD BOTTOM VIEW : SERVO DRIVERS TESTPOINTS

TRAY SERVO

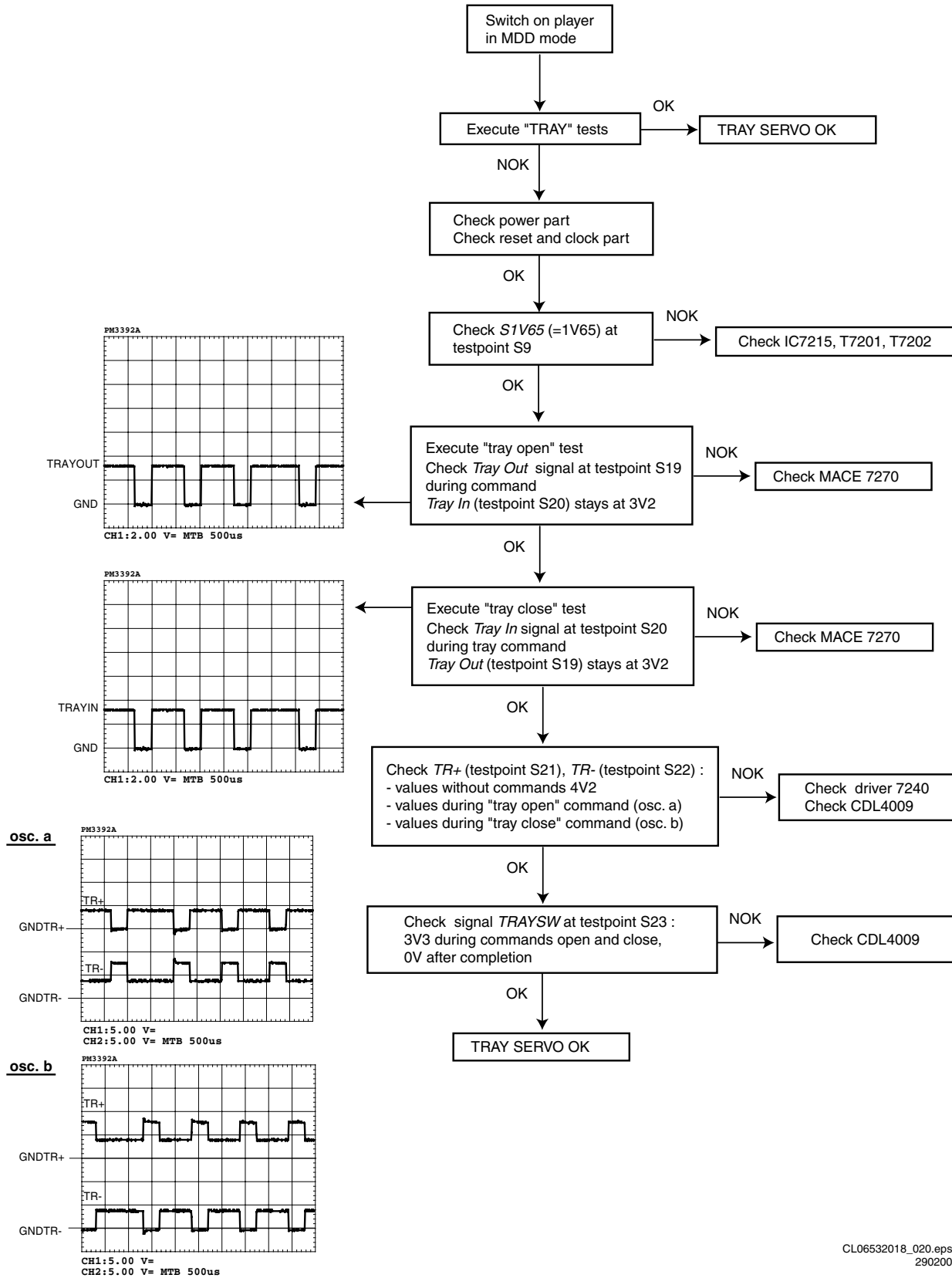

Figure 5-18

5.2.5 Audio signal check

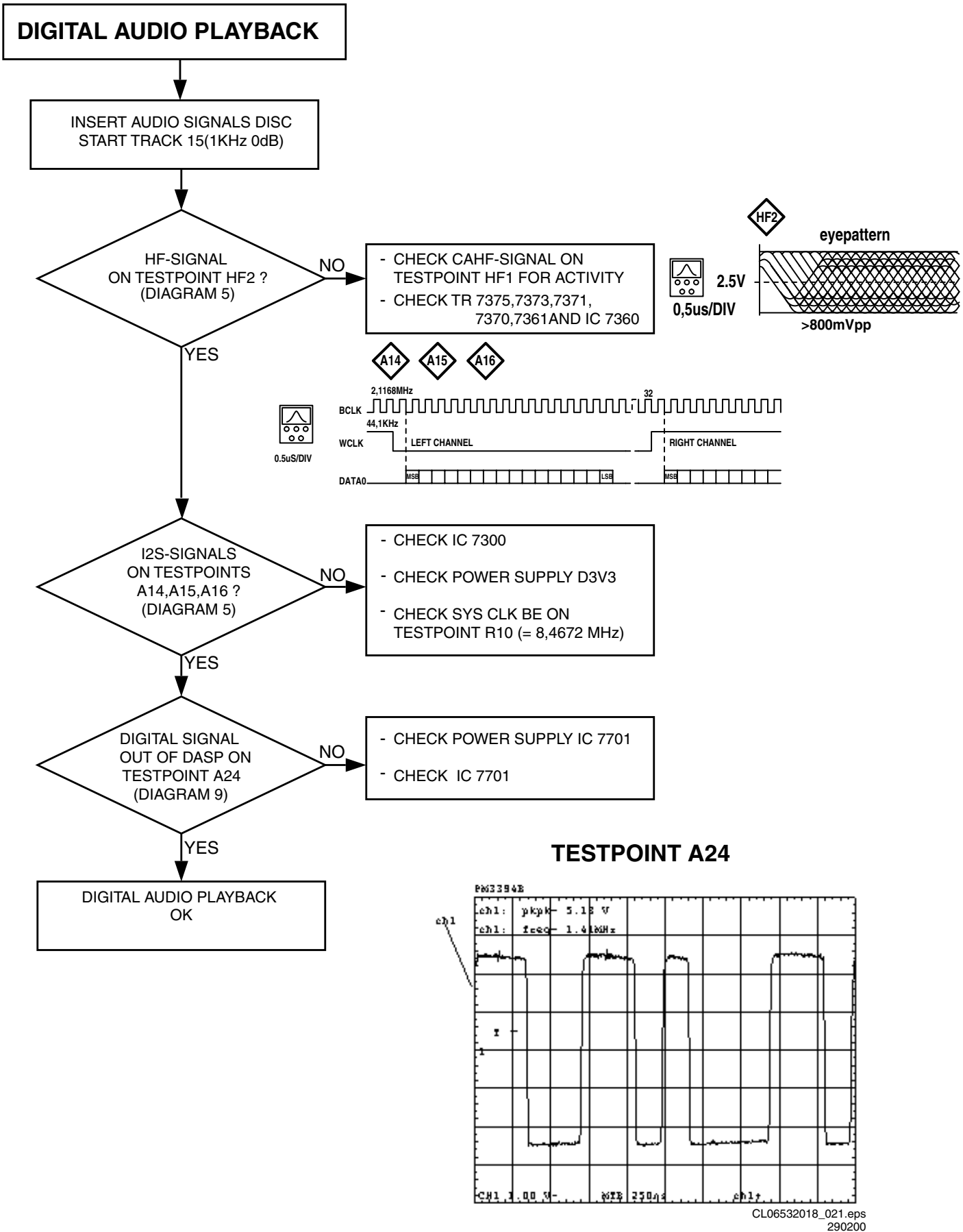

Figure 5-19

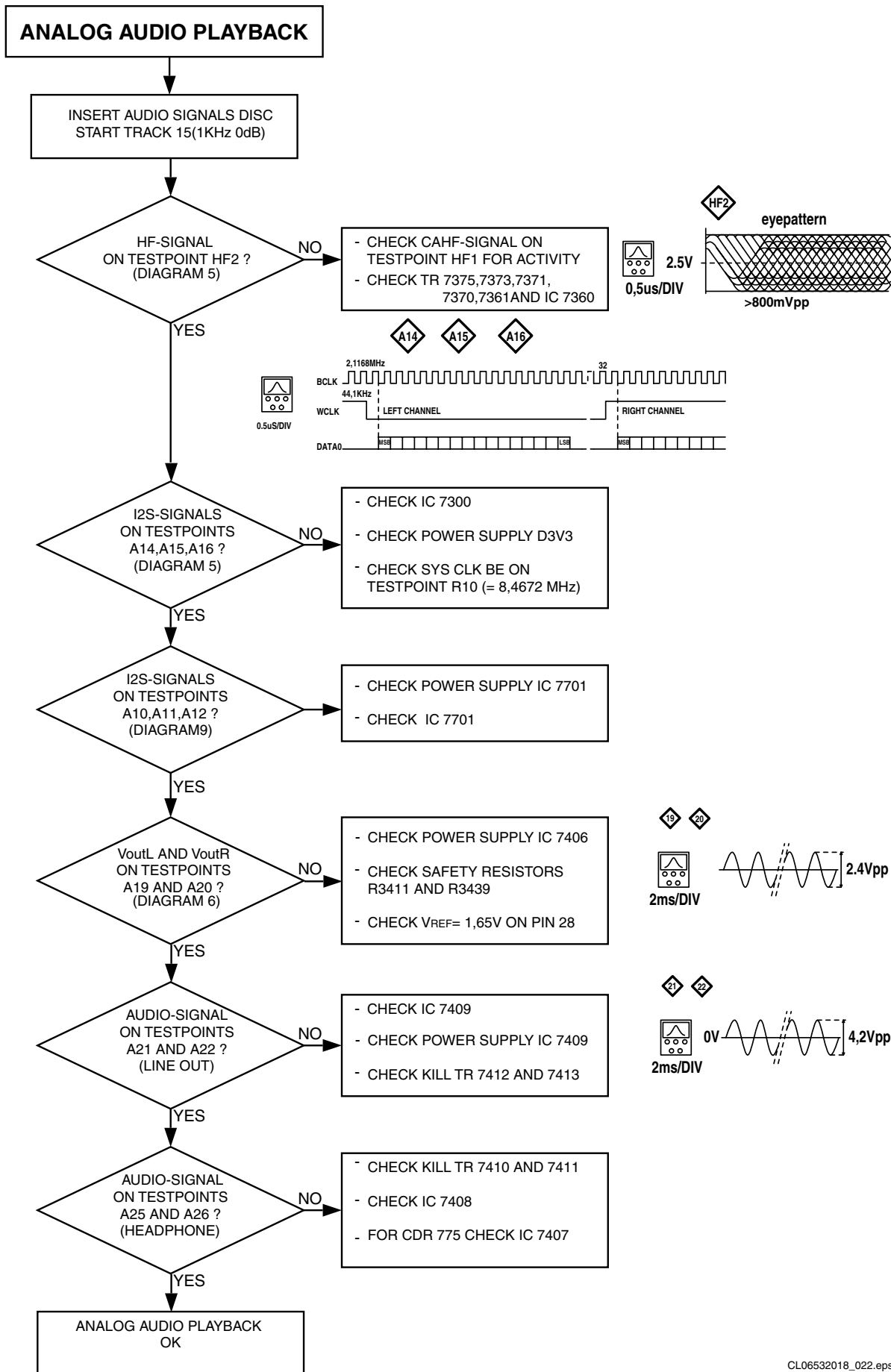

Figure 5-20

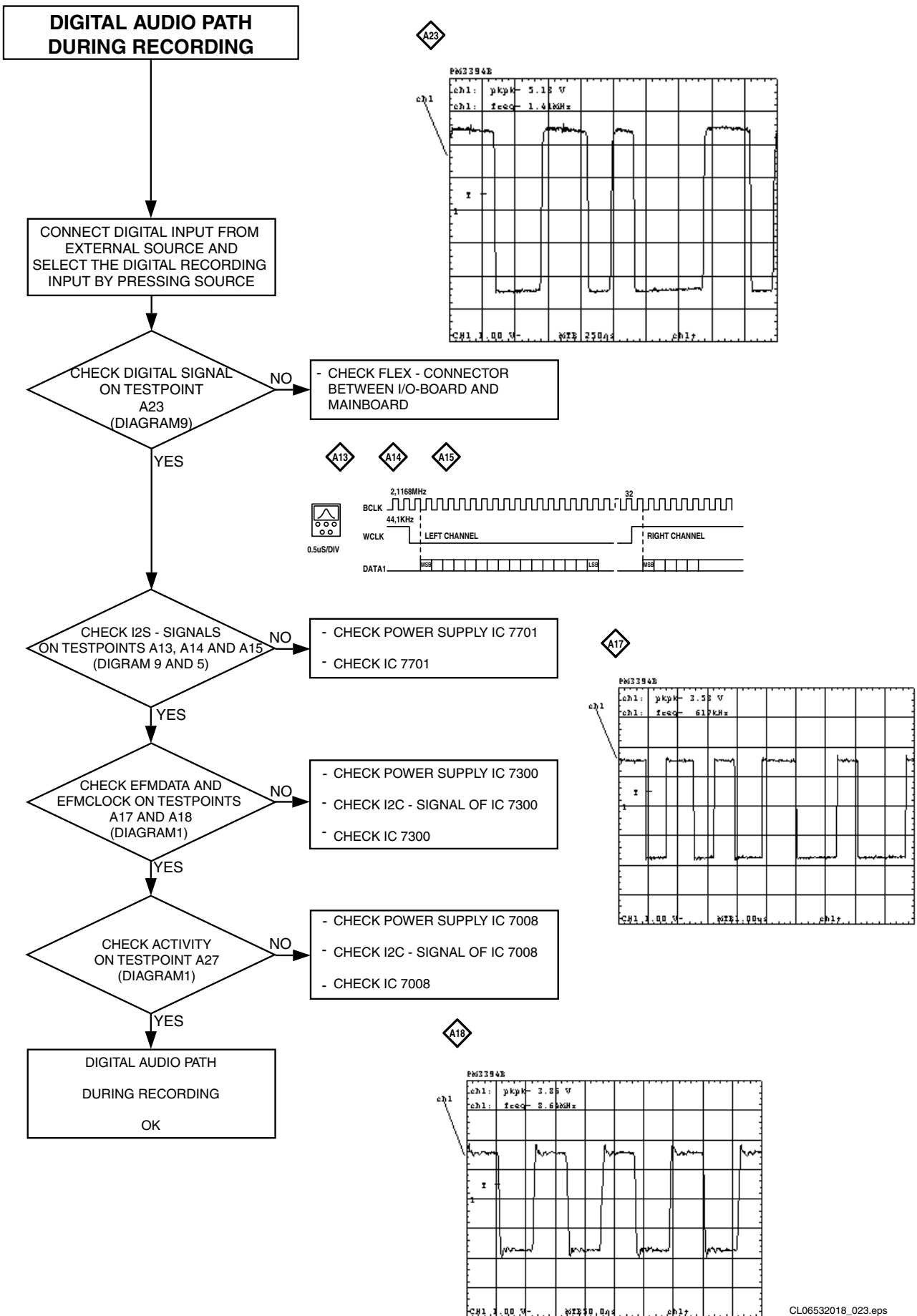

Figure 5-21

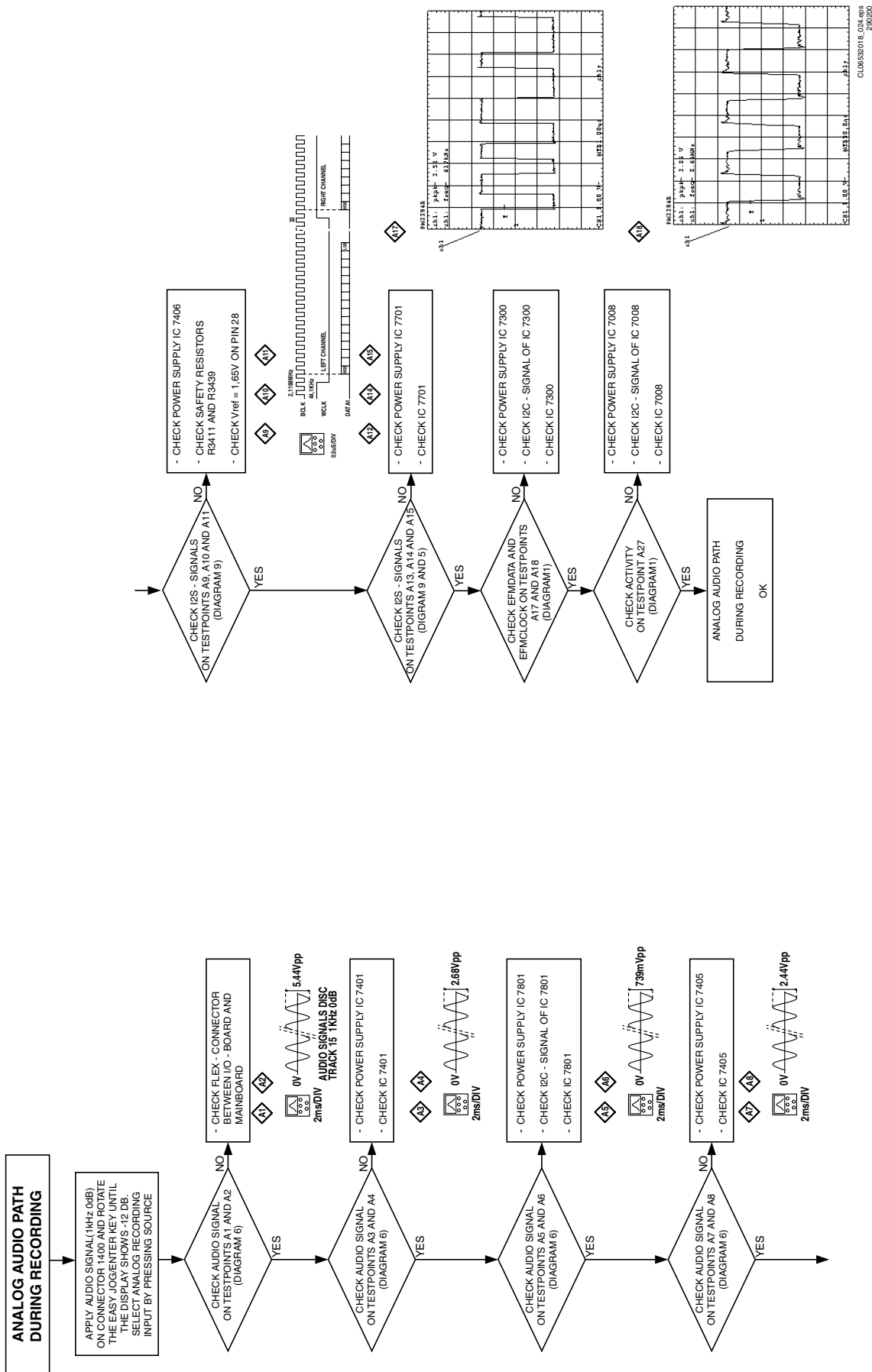

Figure 5-22

8. Alignments & Adjustments

Each CDR-module composed from CDRloader and CDRmainboard has to be matched via SW filled parameters. This adjustment processed in the factory is under investigation to have it implemented into the COMPAIR tool. As long as this adjustment is not possible to be executed in secondline service workshop, the swap of modules and a central repair has to be continued. Adjustment only has to be done at replacement of CDM and concerned servo circuits. Other repairs (audio signals, replacement of adapted Flash roms etc) can be done without infringing the adjusted components.

As soon as COMPAIR CDR is installed this chapter will be adapted via a service information.

Flash Rom IC 7208 (MACE-ROM) is mounted on a socket and can be replaced after lifting up the loader part above it. Flash Rom IC 7703 (DASP-ROM) has to be soldered.

Take care for both ICs Firmware loaded components are mounted.

In case a module is offered with SW versions 1.4 and 91.48, the complete CDR-module should be replaced.

For SW versions 1.23 and 91.63, IC7703 and IC7208 have to be replaced by the latest SW versions.

9. Circuit description

9.1 Description

A separate circuit description concerning the 3rd generation CDR recorders is available with order number 3104 125 40100

9.2 List of Abbreviations

SIGNAL NAME	SIGNAL FLOW	FUNCTION AND DESCRIPTION
+12V	main supply voltage from PSU	+12V supply voltage from PSU
+12VA	supply voltage	+12V supply voltage for Audio part
+5V	main supply voltage from PSU	+5V supply voltage from PSU
+5VA	supply voltage	+5V supply voltage for Audio part
+9SRVPWR	IC7558 → IC7240	PoWeR supply for SeRVo driver IC
12VPWR	supply voltage	+12V supply voltage for servo part
-8V	main supply voltage from PSU	-8V supply voltage from PSU
-8VA	supply voltage	-8V supply voltage for Audio part
A(1:20)	IC7701 → R3818,R3819, R3820, R3821, R3897 → IC7703	Address lines 1 to 20 between DASP and flash ROM
A(10:20)	IC7701 → R3819, R3820, R3821 → IC7702	Address lines 10 to 20 between DASP and DRAM
A1	IC7010 → IC7270	amplitude of the “land” reflection relative to the average EFM, voltage output, OPC input
A1LF, A2LF	CONN1000 → IC7010	satellite photo diodes A1, A2 current output
A2	IC7010 → IC7270	amplitude of the “pit” reflection relative to the average EFM, voltage output, OPC input
A-8V	supply voltage	-8V supply voltage for servo part
AEGER		Analog Error signal GEnerator for Recordable
AINTON	IC7008 → IC7010	Alpha INTegrator ON (to AEGER)
ALE	* IC7270 → R3213 → IC7209, IC7300 * IC7270 → R3230	Address Latch Enable; external address latch strobe line, freeze address when low
ALPHA0	IC7270 → IC7010	analog voltage mode output from OPC D/A converter
ALS	IC7008 → IC7010	Alpha Loop Switch (to AEGER)
ASTROBE	IC7008 → IC7010	Alpha STROBE (to AEGER)
ATIP		Absolute Time In Pre-groove (sync signal)
ATIPSYNC	IC7300 → IC7270	ATIP SYNC signal
ATT	* IC7270 → R3717, R3722 * IC7270 → IC7701	ATTenuation request from MACE2 to audio DAC, active low; means that the output can be attenuated in case of search activities
B1LF, B2LF	CONN1000 → IC7010	satellite photo diodes B1, B2 current output
BCLK	IC7701 → R3898A → IC7300	I ² S1 BitCLock from DASP to CDR60 (playback and record)
BE_RESET	* IC7701 → R3261 → IC7270 * IC7701 → R3716	Basic Engine RESET, active high
BIASC	IC7008 → R3056	BIAS Current switch CDRW output
BKPT	CONN1819, R3907 → IC7701	JTAG mode select / debug mode BreakPoint
C1LF, .. , C4LF	CONN1000 → IC7010	Central photo diodes C1, C2, C3, C4 current output
CAGAIN	R3016,R3115 → IC7010	set-point laser power on disc, current input
CAHF	CONN1000 → C2374	Central Aperture (central photo diodes) High Frequency current output (C1+C2+C3+C4)
CALF	IC7010 → IC7270	Central Aperture (central photo diodes) Low-pass Filtered signal (DC coupled EFM signal), voltage output, OPC input
CAS0	IC7701 → IC7702	Column Address Strobe DRAM for upper byte

SIGNAL NAME	SIGNAL FLOW	FUNCTION AND DESCRIPTION
CAS1	IC7701 → IC7702	Column Address Strobe DRAM for lower byte
CDR	IC7008 → IC7355	CDR strategy detected output (active high)
CDR60CFLG	IC7300 → R3382B → CONN1812	serial output of error corrector status information of the CDR60-decoder, to be measured at test connector
CDR60CL1	IC7300 → R3382C → CONN1812	output of CLock signal for testing system clock of IC CDR60 at test connector
CDR60CS	IC7270 → R3235B → R3702, IC7300	CDR60 Chip Select, active high
CDR60INT	IC7300 → IC7270	CDR60 INTerrupt line, active low
CDR60LWRT	IC7300 → R3048	CDR60 Laser WRiTe control output
CDR60MEAS1	IC7300 → R3382A → CONN1812	serial output of information about jitter, PLL frequency and asymmetry of bit recovery block in CDR60, to be measured at test connector
CDR60PLL	IC7270 → R3305 → IC7300	CDR60 clock multiplier enable, active high
CDRW	* IC7355D → IC7355C * IC7355D → CONN1000	inverted CDR-strategy-detected signal
CLK_OUT	IC7701 → R3771 → CONN1819	system CLock OUT
CLK_SYS	IC7701 → R3727, R3731	oscillator output
COS-	CONN1220 → IC7225B	Hall feedback signal from sledge motor
COS+	CONN1220 → IC7225B	Hall feedback signal from sledge motor
CSFLASH	IC7701 → IC7703	Chip Select for FLASH or boot device
CSRAM	IC7270 → R3235A → R3703, IC7802	Chip Select SRAM, active low
D(16:31)	IC7701 ↔ R3822, R3823, R3824, R3825 ↔ IC7703, IC7702	Databus bit 16 to 31 between DASP, flash ROM and DRAM
D3V3	supply voltage	+3,3V supply voltage for Digital part
D5V	supply voltage	+5V supply voltage for Digital part
D5VS	supply voltage	+5V supply voltage for Servo part
DALPHA	IC7010 → R3037	ALPHA error signal for laser power control
DASP		Digital Audio Signal Processor
DATAI	IC7701 → R3898C → IC7300	I ² S1 DATA In from DASP to CDR60 (recording)
DATAO	IC7300 → R3314 → IC7701	I ² S1 DATA Out from CDR60 to DASP (playback)
DEEMP	* IC7270 → R3719, R3724 * IC7270 → IC7701	DE-EMphasis control for audio DAC from MACE2, active high; means that de-emphasis is needed in digital filter
DELTAP	IC7016 → R3126	DELTA Power current source drive signal from XDAC
DIG_OUT_C	IC7701 → R3706 → C2707, CONN1400	Common DIGital OUTput (consumer)
DISPLAY_INT	F934 → R3812, IC7701	DISPLAY INTerrupt
DMON	IC7270 → R3324	power save at stop, active low
DOBM_CD	CONN1708, C2731 → R3757 → R3903 → IC7701	Digital Output (EBU output) from CD player in CDR775 to DASP
DOBM_CDR	IC7300 → R3382D → C2379, IC7701	Digital Output (EBU output) from CDR60 to DASP
DRAM_RW	IC7701 → IC7702	Read/Write strobe for DRAM
DSA_ACK_CD	* IC7701 ↔ R3830 ↔ R3831	Data/Strobe/Acknowledge serial communication

SIGNAL NAME	SIGNAL FLOW	FUNCTION AND DESCRIPTION
	↔ CONN1708 * IC7701 ↔ R3830 ↔ C2735	between DASP and CD-player in CDR775
DSA_ACK_CDR	* IC7701 → R3729 → IC7270, CONN1830 * IC7701 → R3729 → R3769	Data/Strobe/Acknowledge serial communication between MACE2 and DASP for CDR; acknowledge input for MACE2 is strobe output for DASP
DSA_DATA_CD	* IC7701 ↔ R3828 ↔ R3829 ↔ CONN1708 * IC7701 ↔ R3828 ↔ C2733	Data/Strobe/Acknowledge serial communication between DASP and CD-player in CDR775
DSA_DATA_CDR	* IC7270↔R3246 ↔ R3813 ↔ IC7701, CONN1830 * IC7270↔R3246 ↔ R3767	Data/Strobe/Acknowledge serial communication between MACE2 and DASP for CDR
DSA_STR_CD	* IC7701 ↔ R3835 ↔ R3832 ↔ CONN1708 * IC7701 ↔ R3835 ↔ C2734	Data/Strobe/Acknowledge serial communication between DASP and CD-player in CDR775
DSA_STR_CDR	* IC7270 → R3245 → IC7701, CONN1830 * IC7270 → R3245 → R3768	Data/Strobe/Acknowledge serial communication between MACE2 and DASP for CDR (strobe output for MACE2 is acknowledge input for DASP)
DSCLK	CONN1819, R3908 → IC7701	reset in / Debug Serial CLock in
DSI	CONN1819, R3909 → IC7701	JTAG reset in / Debug Serial clock In
EFM		Eight to Fourteen Modulation = modulation method used for CD storage, also the actual raw CD signal as written or read on or from the CD disc
EFMCLK	IC7300 → IC7008	EFM CLock output
EFMDATA	IC7300 → IC7008	EFM DATA output
EFMTIM3		EFM TIMing generator
EPON	IC7008 → R3010 IC7008 → C2010	Erase Power ON
EPONO	IC7008 → R3107	Erase Power ON Open drain output
EPONRC	R3004 → CONN1000	Erase Power ON (after RC circuit)
ERASEC	IC7008 → R3087	ERASE Current switch CDRW output
ERON	IC7008 → IC 7010	ERror ON (to AEGER)
EXT_DIG_IN1	CONN1400 → IC7701	EXTernal DIGital INput 1
EXT_DIG_IN2	CONN1702, C2767, C2721 → R3701 → IC7701	EXTernal DIGital INput 2 (CDR950 only)
EXT_OPT_IN	CONN1400, C2722 → R3708 → IC7701	EXTernal OPTical INput
F_READY	* IC7703 → R3817 → IC7701 * CONN1701 → IC7701	Flash READY detection, this line is forced low as long as the flash is busy with erase or program algorithm
F_RW	IC7701 → IC7708B	Read/Write strobe for Flash ROM
FEN	IC7010 → IC7270	Focus Error Normalized current output
FOC-	IC7240 → CONN1000	FOCus actuator drive signal negative connection
FOC+	IC7240 → CONN1000	FOCus actuator drive signal positive connection
FS30V	D6500 → CONN1000	Forward Sense diode 30V power supply
FSA	CONN1000 → T7119, T7120	Forward Sense photo diode current output
FSCLR	IC7008 → IC7126	Forward Sense signals CLear switch
FSOF	IC7008 → R3052	Forward Sense photo diode sampling OFF

SIGNAL NAME	SIGNAL FLOW	FUNCTION AND DESCRIPTION
FSON	IC7008 → R3051	Forward Sense photo diode sampling ON
FSR	R3040 → IC7270	Forward Sense signal while Reading for read control loop
FSRS	IC7008 → IC7126D	Forward Sense photo diode Read Sampling
FSW	R3050 → IC7270	Forward Sense signal while Writing for write control loop
FSWS	IC7008 → IC7126C	Forward Sense photo diode Write Sampling
FWEN	IC7270 → IC7208, R3806	Flash EPROM Write ENable
HALL_U, HALL_V, HALL_W	IC7330 → IC7300, CONN1812	HALL feedback signals from turn table motor via hall motor driver
HFS0	IC7270 → R3249 → IC7360	select HF circuit
I ² C		Inter IC
I ² C_CLK	* IC7701, R3711 → R3715 → C2709 → F934 * IC7701, R3711 → IC7801	I ² C CLock line used for display slave processor and digital potmeter
I ² C_DATA	* IC7701, R3712 ↔ R3713 ↔ C2708, R3714 ↔ F934 * IC7701, R3712 ↔ IC7801	I ² C DATA line used for display slave processor and digital potmeter
I ² CL	R3248B → IC7207, R3247C	I ² C CLock line
I ² C_SCL	* IC7207 → IC7008 * IC7207 → IC7010 * IC7207 → R3248B	I ² C Serial CLock line
I ² C_SDA	* IC7207 ↔ IC7008 * IC7207 ↔ IC7010 * IC7207 ↔ R3248A	I ² C Serial DATA line
I ² DA	R3248A ↔ IC7270, R3247D	I ² C DATA line
I ² S_BCLK_AI	IC7701 → R3814 → IC7406	I ² S4 Bit CLock for CODEC (ADC for CDR950) Analog Input (record from analog source)
I ² S_BCLK_AO	IC7701 → R3894A → IC7406	I ² S2 Bit CLock for CODEC (DAC for CDR950) Analog Output
I ² S_BCLK_CD	CONN1708, C2739 → R3834 → IC7701	I ² S3 Bit CLock from CD player (record n=2) (CDR775 only)
I ² S_BCLK_MIC	CONN1708, C2739 → R3834 → IC7701	I ² S3 Bit CLock from MICrophone (CDR950 only)
I ² S_DATA_AI	IC7406 → IC7701	I ² S4 DATA from CODEC (ADC for CDR950) Analog Input (record from analog source)
I ² S_DATA_AO	IC7701 → R3894C → IC7406	I ² S2 DATA for CODEC (DAC for CDR950) Analog Output
I ² S_DATA_CD	CONN1708, C2738 → R3836 → IC7701	I ² S3 DATA from CD player (record n=2) (CDR775 only)
I ² S_DATA_MIC	CONN1708, C2738 → R3836 → IC7701	I ² S3 DATA from MICrophone (CDR950 only)
I ² S_WS_AI	IC7701 → R3743 → IC7406	I ² S4 Word CLock for CODEC (ADC for CDR950) Analog Input (record from analog source)
I ² S_WS_AO	IC7701 → R3894B → IC7406	I ² S2 Word CLock for CODEC (DAC for CDR950) Analog Output
I ² S_WS_CD	CONN1708, C2740 → R3833 → IC7701	I ² S3 Word CLock from CD player (record n=2) (CDR775 only)

SIGNAL NAME	SIGNAL FLOW	FUNCTION AND DESCRIPTION
I ² S_WS_MIC	CONN1708, C2740 → R3833 → IC7701	I ² S3 Word CLock from MICrophone (CDR950 only)
I ² S1_MS	IC7270 → R3910, IC7701	I ² S1 Master-Slave interrupt from MACE2
IE	T7121 → CONN1000	laser Erase drive current signal
INT_COPY_ANA	* IC7701 → R3721 → IC7401 * IC7701 → R3721 → R3410	select INTernal COPY ANALog (in case of copy protected disc or track on CD drive) (CDR775 only)
IR	* T7135 → CONN1000 * T7135 → R3056 * T7135 → IC7008	laser Read drive current signal
IW	* T7122 → CONN1000 * T7122 → D6003	laser Write drive current signal
KEY_PRESSED	IC7706B → R3816 → IC7701	KEY PRESSED interrupt
KILL	T7560, T7561, R3560 → CONN1400, R3424, R3428	KILL signal from power supply part to audio outputs
KILL_OUT	IC7701 → R3532	disables the KILL activity from the PSU; 1 = no kill, 0 = kill active
L12V	supply voltage	+12V supply voltage for servo/Laser part
L3_CLK	IC7701 → R3725 → IC7406	L3 interface CLock line / control CODEC (not for CDR950)
L3_DATA	IC7701 ↔ R3728 ↔ IC7406	L3 interface DATA line with CODEC (not for CDR950)
L3_MODE	IC7701 → R3735 → IC7406	L3 interface MODE line selects data or address transfer mode for CODEC (not for CDR950)
L5V	supply voltage	+5V supply voltage for servo/Laser part
L-5V	supply voltage	-5V supply voltage for servo/Laser part
LASCK	IC7270 ↔ R3248D	Clock line DAC LASer control
LASDACCK	R3248D ↔ IC7016	Clock line DAC LASer control
LASDACDI	R3248C ↔ IC7016	Data line DAC LASer control
LASDACLD	R3212 ↔ IC7016	LoaD line DAC LASer control
LASDD	IC7270 ↔ R3248C	Data line DAC LASer control
LASLD	* IC7270 ↔ R3238 ↔ R3212 * IC7270 ↔ R3232	LoaD line DAC LASer control
LEFT	CONN1708, C2743 → IC7401C, IC7407C	audio output LEFT channel from CD-player in CDR775
LLP	IC7270 → IC7300	Laser Low Power (active high), switches the laser from write to read power whenever the device tends to go offtrack
LWRT	R3048 → IC7008	Laser WRiTe control input
MA(16:17)	IC7270 ↔ IC7208	bank switch higher address lines
MA(8:15)	IC7270 ↔ IC7802 ↔ IC7208	address bus high byte
MACE2		Mini All Cd Engine (minus decoder + OPC + PCS + extra RAM)
MAD(0:7)	IC7270 ↔ IC7209 ↔ IC7802 ↔ IC7208 ↔ IC7300	bi-directional data bus / address bus low byte
MIRN	IC7010 → IC7270	MIRror Normalized (disc reflection) current output
MOTO1	IC7300 → IC7355A	turn table MOTOr control output

SIGNAL NAME	SIGNAL FLOW	FUNCTION AND DESCRIPTION
MRDN	IC7270 → R3276 → R3242A, IC7802, IC7300	Master ReaD, read strobe for external peripherals, active low
MUTE	* IC7270 → R3718, R3723 * IC7270 → IC7701	MUTE control from MACE2 to DASP, active low
MWRN	IC7270 → R3280 → R3242B, IC7802, IC7300	Master WRite, write strobe for external peripherals, active low
NMUTE	IC7701 → R3726, IC7406	MUTE output, low active
OFFTRACK	IC7270 → IC7300	OFFTRACK detection flag
OPC		Optimum Power Calibration
P12VKILL	supply voltage	+12V supply voltage for KILL-circuit
PCS		Position Control Sledge
PCSCOS	IC7225B, C2229 → IC7270, CONN1812	Position Control Sledge COS feedback signal
PCSSIN	IC7225A, C2227 → IC7270, CONN1812	Position Control Sledge SIN feedback signal
PDAR		Photo Diode Amplifier Recordable
PERASE	R3036, R3031, R3030, R3029, R3028, R3027, R3020 → IC7002C, R3043, T7113	laser Power switch for ERASE
POWER_UP	IC7270 → R3243C, R3556, R3538	standby pin, high level activates essential powers necessary for full function; overrules HI_POWER setting
PPN	IC7010 → IC7050C	Push-Pull signal, Normalized, balanced, voltage output
PRCOARSE	IC7016 → R3057	drive signal from Power Read COARSE DAC for read current source
PRFINE	IC7016 → R3058	drive signal from Power Read FINE DAC for read current source
PROF_EBU	IC7701 → CONN1820	PROFessional digital output (CDR950 only)
PSEn	* IC7270 → R3260 → IC7208 * IC7270 → R3231	Program Store ENable; external ROM output enable line, active low
PW	R3081 → IC7008	Write Power signal to OPC input of MACE2
PWB	IC7001C → IC7016	drive signal to XDAC's for write and erase current sources and VCAGAIN
PWD	* IC7016 → IC7002B * IC7016 → IC7002C	drive signal from XDAC for write and erase current sources
PWMAX	IC7016 → R3073	PW MAXimum signal from DAC used for determining set point for laser power during writing
PWMIN	IC7016 → R3072	PW MINimum signal from DAC used for determining set point for laser power during writing
PWRITE	R3035, R3026, R3025, R3024, R3023, R3022, R3021 → IC7002B, R3044, T7124	laser Power switch for WRITE
RAD-	IC7240 → CONN1000	Radial actuator drive signal negative connection
RAD+	IC7240 → CONN1000	Radial actuator drive signal positive connection
RAS0	IC7701 → IC7702	Row Address Strobe DRAM
RCK	IC7300 → R3319 → IC7701	EIAJ subcode clock from CDR60 to DASP (CD text interface)
RDGAIN1	IC7008 → R3054	forward sense ReaD GAIN switch 1

SIGNAL NAME	SIGNAL FLOW	FUNCTION AND DESCRIPTION
RDGAIN2	IC7008 → C2027	forward sense ReaD GAIN switch 2
RDGAIN3	IC7008 → C2060	forward sense ReaD GAIN switch 3
RE	IC7010 → IC7215A	Radial Error signal for fast track counting, voltage output
RECORDING	* IC7008 → IC7010 * IC7008 → CONN1000 * IC7008 → IC7355C	RECORDING output (active high)
REN	IC7010 → IC7270	Radial Error Normalized current output
RIGHT	CONN1708, C2742 → IC7401A, IC7407A	audio output RIGHT channel from CD-player in CDR775
RXD_TOOL	CONN1818 → IC7701	Receive of UART for test TOOL
S1V65	Reference Voltage	1.65V delivered by IC7215B for Servo part
S2V9	Reference Voltage	2.9V delivered by IC7010 for Servo part
SEL_HP_OUT	* IC7701 → R3720 → IC7407	SElect HeadPhone OUTput in DJ-mode (for CDR775 only)
SFSY	IC7701 → R3756 → IC7300	EIAJ subcode synchronisation from DASP to CDR60 (CD text interface)
SIN-	CONN1220 → IC7225A	Hall feedback signal from sledge motor
SIN+	CONN1220 → IC7225A	Hall feedback signal from sledge motor
SL-	IC7240 → R3265 → CONN1220	SLedge motor drive signal negative connection
SL+	IC7240 → CONN1220	SLedge motor drive signal positive connection
SRSTN	IC7270 → R3243B, IC7300	Slave ReSeT out (CDR60 reset), active low
STANDBY	IC7270 → R3807 → R3887 → IC7701	STANDBY pin, high level activates essential powers necessary for full function; overrules HI_POWER setting
SUB	IC7701 → R3710 → IC7300	EIAJ subcode data from DASP to CDR60 (CD text interface)
SYS_CLK_11W	IC7701 → R3732 → IC7406	11.2896 MHz SYStem CLock for AD/DA datapath
SYS_CLK_16W	IC7701 → R3894D → IC7706A	16.9344 MHz SYStem CLock for producing SYS_CLK_BE
SYS_CLK_8W	IC7706A → R3815 → CONN1708	SYStem CLock CD player (8.4672 MHz) (CDR775 only)
SYS_CLK_BE	IC7706A → R3826 → IC7270	SYStem CLock Basic Engine (8.4672 MHz)
SYS_RESET	* IC7701 → R3758 → CONNF934 * IC7701 → R3770 → T7707 → CONN1708	SYStem RESET to display assy (and CD player for CDR775)
TCK	CONN1819 → R3906, IC7701	JTAG Clock signal
TDSO	IC7701 → CONN1819	JTAG Serial Data Out / debug data out
TERMB	IC7270 ↔ CONN1818	UART connection with MACE
TLN	IC7010 → IC7270	Track Loss Normalized current output
TR-	IC7240 → CONN1200	TRay motor drive signal negative connection
TR+	IC7240 → CONN1200	TRay motor drive signal positive connection
TRACE99_RXD	CONN1818 → R3838, IC7701	TRACE99 test tool receive data
TRACE99_TXD	IC7701 → CONN1818	TRACE99 test tool transmit data
TRAYIN	IC7270 → IC7240	move TRAY IN line, active low

SIGNAL NAME	SIGNAL FLOW	FUNCTION AND DESCRIPTION
TRAYOUT	IC7270 → IC7240	move TRAY OUT line, active low
TRAYSW	* CONN1200 → R3747 * CONN1200 → R3748	TRAY SWitch signal from loader assy
TRAYSWF	R3748, C2214 → IC7270	Filtered TRAY SWitch signal, low is completely out or in
TXD_TOOL	IC7701 → CONN1818	Transmit of UART for test TOOL
U+, U-, V+, V-, W+, W-	CONN1330 → IC7330	hall feedback signals from turn table motor to hall motor driver
UCOIL, VCOIL, WCOIL	IC7330 → CONN1330	drive signals for turn table motor
VCAGAIN	IC7016 → IC7005A	set-point laser power on disc, voltage output
VDC1	CONN1500 → CONNF934	supply voltage for display assy
VDC2	CONN1500 → CONNF934	supply voltage for display assy
VFO	IC7270 → R3295 → R3244	FOcus actuator drive output
VFTD	CONN1500 → CONNF934	Voltage Fluorescent Tube Display (display assy)
VRA	IC7270 → R3297 → R3254	RAdial actuator drive output
VSL	IC7270 → R3299 → IC7240	SLedge actuator drive output
WCLK	IC7701 → R3898B → IC7300	I ² S1 WordCLock from DASP to CDR60 (playback and record)
WOBBLE	IC7050C → IC7300	analog WOBBLE signal of pre-groove detected by PPN-signal
WPON	* IC7008 → R3009 * IC7008 → C2009	Write Power ON
WPONO	IC7008 → R3106	Write Power ON Open drain output
WPONRC	R3003 → CONN1000	Write Power ON (after RC circuit)
XDAC		multiplying DAC

10. Spareparts List

ELECTRICAL PARTSLIST MAINBOARD CDR'99

ITEM	CODENUMBER	DESCRIPTION	CDR775	CDR570	CDR770	CDR950
1000	482226710666	30 P. FEM.	+	+	+	+
1541	482225251173	19398E1(1,000A)	+	+	+	+
1542	482225251173	19398E1(1,000A)	+	+	+	+
1543	482225251173	19398E1(1,000A)	+	+	+	+
1707	482224210757	33.868 000MHZ SM 20P CX-11F	+	+	+	+
1708	482226760409	CONN 22P FEMALE	+	-	-	-
1820	482226710666	30 P. FEM.	-	-	-	+
2001	482212612105	CER2 0805 X7R 50V 33NF PM5	+	+	+	+
2002	482212614585	100NF 10% X7R 0805 50V	+	+	+	+
2003	482212614585	100NF 10% X7R 0805 50V	+	+	+	+
2009	482212233753	150PF 5%NP0 50V	+	+	+	+
2010	482212233753	150PF 5%NP0 50V	+	+	+	+
2011	482212614585	100NF 10% X7R 0805 50V	+	+	+	+
2012	482212614585	100NF 10% X7R 0805 50V	+	+	+	+
2013	482212614585	100NF 10% X7R 0805 50V	+	+	+	+
2014	482212614585	100NF 10% X7R 0805 50V	+	+	+	+
2015	482212614585	100NF 10% X7R 0805 50V	+	+	+	+
2016	482212614585	100NF 10% X7R 0805 50V	+	+	+	+
2018	482212613694	68PF 1% NP0 63V	+	+	+	+
2019	482212614585	100NF 10% X7R 0805 50V	+	+	+	+
2020	482212613188	15NF 5% X7R 63V	+	+	+	+
2021	482212233177	10NF 20% X7R 50V	+	+	+	+
2022	482212233177	10NF 20% X7R 50V	+	+	+	+
2023	482212614305	100NF 10% X7R 16V 0603 CER2	+	+	+	+
2024	482212614305	100NF 10% X7R 16V 0603 CER2	+	+	+	+
2025	482212614305	100NF 10% X7R 16V 0603 CER2	+	+	+	+
2026	222286115272	CER1 0805 NP0 50V	+	+	+	+
2027	222286115272	CER1 0805 NP0 50V	+	+	+	+
2028	532212232531	100PF 5%NP0 50V	+	+	+	+
2029	532212232531	100PF 5%NP0 50V	+	+	+	+
2030	532212231647	1NF10%X7R 63V	+	+	+	+
2031	482212614585	100NF 10% X7R 0805 50V	+	+	+	+
2032	482212614305	100NF 10% X7R 16V 0603 CER2	+	+	+	+
2033	482212614305	100NF 10% X7R 16V 0603 CER2	+	+	+	+
2037	482212614305	100NF 10% X7R 16V 0603 CER2	+	+	+	+
2038	482212614305	100NF 10% X7R 16V 0603 CER2	+	+	+	+
2039	482212233177	10NF 20% X7R 50V	+	+	+	+
2040	482212233172	390PF 5% NP0 50V	+	+	+	+
2041	532212234099	470PF10%X7R 63V	+	+	+	+
2042	532212233538	150PF 2%NP0 63V	+	+	+	+
2043	532212231647	1NF10%X7R 63V	+	+	+	+
2044	482212613486	15PF 2% NP0 63V	+	+	+	+
2045	482212614305	100NF 10% X7R 16V 0603 CER2	+	+	+	+
2046	482212614305	100NF 10% X7R 16V 0603 CER2	+	+	+	+
2047	482212614305	100NF 10% X7R 16V 0603 CER2	+	+	+	+
2048	482212614305	100NF 10% X7R 16V 0603 CER2	+	+	+	+
2049	532212611579	3,3NF10%X7R 63V	+	+	+	+
2050	482212614238	CER2 0603 X7R 50V 2N2 COL R	+	+	+	+
2052	482212614305	100NF 10% X7R 16V 0603 CER2	+	+	+	+
2053	482212614305	100NF 10% X7R 16V 0603 CER2	+	+	+	+
2054	482212614238	CER2 0603 X7R 50V 2N2 COL R	+	+	+	+
2056	532212611579	3,3NF10%X7R 63V	+	+	+	+
2057	482212614305	100NF 10% X7R 16V 0603 CER2	+	+	+	+
2058	482212614305	100NF 10% X7R 16V 0603 CER2	+	+	+	+
2059	482212614305	100NF 10% X7R 16V 0603 CER2	+	+	+	+
2060	532212611579	3,3NF10%X7R 63V	+	+	+	+
2061	482212411947	10UF 20% 16V	+	+	+	+

ITEM	CODENUMBER	DESCRIPTION	CDR775	CDR570	CDR770	CDR950
2063	482212614305	100NF 10% X7R 16V 0603 CER2	+	+	+	+
2078	482212614305	100NF 10% X7R 16V 0603 CER2	+	+	+	+
2080	482212614238	CER2 0603 X7R 50V 2N2 COL R	+	+	+	+
2081	532211680853	560PF 5%NP0 63V	+	+	+	+
2082	482212614238	CER2 0603 X7R 50V 2N2 COL R	+	+	+	+
2083	482212613956	68PF 5% NP0 63V CASE 0603	+	+	+	+
2084	482212232627	2.7NF10%X7R 50V	+	+	+	+
2126	482212614585	100NF 10% X7R 0805 50V	+	+	+	+
2207	482212614305	100NF 10% X7R 16V 0603 CER2	+	+	+	+
2208	482212614585	100NF 10% X7R 0805 50V	+	+	+	+
2209	482212614585	100NF 10% X7R 0805 50V	+	+	+	+
2214	482212614305	100NF 10% X7R 16V 0603 CER2	+	+	+	+
2216	482212233777	47PF 5%NP0 63V	+	+	+	+
2217	482212614494	22NF 10% X7R 25V 0603	+	+	+	+
2218	482212614585	100NF 10% X7R 0805 50V	+	+	+	+
2220	319801734730	CER2 0603 X7R 16V 47N COL	+	+	+	+
2221	482212614585	100NF 10% X7R 0805 50V	+	+	+	+
2222	482212614226	82PF 5% NP0 50V 0603	+	+	+	+
2224	482212614305	100NF 10% X7R 16V 0603 CER2	+	+	+	+
2225	482212614585	100NF 10% X7R 0805 50V	+	+	+	+
2226	482212614585	100NF 10% X7R 0805 50V	+	+	+	+
2227	319801631020	CER1 0603 NP0 25V 1N	+	+	+	+
2228	482212614585	100NF 10% X7R 0805 50V	+	+	+	+
2229	319801631020	CER1 0603 NP0 25V 1N	+	+	+	+
2230	482212614494	22NF 10% X7R 25V 0603	+	+	+	+
2231	482212614494	22NF 10% X7R 25V 0603	+	+	+	+
2232	482212614494	22NF 10% X7R 25V 0603	+	+	+	+
2233	319801631020	CER1 0603 NP0 25V 1N	+	+	+	+
2234	319801631020	CER1 0603 NP0 25V 1N	+	+	+	+
2235	319801631020	CER1 0603 NP0 25V 1N	+	+	+	+
2240	482212614305	100NF 10% X7R 16V 0603 CER2	+	+	+	+
2241	482212614305	100NF 10% X7R 16V 0603 CER2	+	+	+	+
2242	482212441796	22UF20% 16V	+	+	+	+
2243	482212614305	100NF 10% X7R 16V 0603 CER2	+	+	+	+
2255	482212614305	100NF 10% X7R 16V 0603 CER2	+	+	+	+
2256	482212614305	100NF 10% X7R 16V 0603 CER2	+	+	+	+
2272	482212614585	100NF 10% X7R 0805 50V	+	+	+	+
2273	482212614585	100NF 10% X7R 0805 50V	+	+	+	+
2274	482212614305	100NF 10% X7R 16V 0603 CER2	+	+	+	+
2275	482212614585	100NF 10% X7R 0805 50V	+	+	+	+
2276	482212614585	100NF 10% X7R 0805 50V	+	+	+	+
2277	482212614585	100NF 10% X7R 0805 50V	+	+	+	+
2278	482212614585	100NF 10% X7R 0805 50V	+	+	+	+
2283	482212614305	100NF 10% X7R 16V 0603 CER2	+	+	+	+
2284	482212614585	100NF 10% X7R 0805 50V	+	+	+	+
2285	482212614585	100NF 10% X7R 0805 50V	+	+	+	+
2286	482212233127	2,2NF10%X7R 63V	+	+	+	+
2287	482212233127	2,2NF10%X7R 63V	+	+	+	+
2288	532212232654	22NF10%X7R 63V	+	+	+	+
2289	482212614305	100NF 10% X7R 16V 0603 CER2	+	+	+	+
2291	482212614585	100NF 10% X7R 0805 50V	+	+	+	+
2300	482212614305	100NF 10% X7R 16V 0603 CER2	+	+	+	+
2302	482212614305	100NF 10% X7R 16V 0603 CER2	+	+	+	+
2303	482212614305	100NF 10% X7R 16V 0603 CER2	+	+	+	+
2304	482212614305	100NF 10% X7R 16V 0603 CER2	+	+	+	+
2305	482212614305	100NF 10% X7R 16V 0603 CER2	+	+	+	+
2306	482212614305	100NF 10% X7R 16V 0603 CER2	+	+	+	+
2308	222286115222	CER1 0805 NP0 50V 2N2 PM5	+	+	+	+
2309	222286115222	CER1 0805 NP0 50V 2N2 PM5	+	+	+	+
2310	222286115222	CER1 0805 NP0 50V 2N2 PM5	+	+	+	+
2314	482212614305	100NF 10% X7R 16V 0603 CER2	+	+	+	+

ITEM	CODENUMBER	DESCRIPTION	CDR775	CDR570	CDR770	CDR950
2315	482212614305	100NF 10% X7R 16V 0603 CER2	+	+	+	+
2316	482212614305	100NF 10% X7R 16V 0603 CER2	+	+	+	+
2317	532212611579	3,3NF10%X7R 63V	+	+	+	+
2318	482212614585	100NF 10% X7R 0805 50V	+	+	+	+
2319	482212614585	100NF 10% X7R 0805 50V	+	+	+	+
2320	482212614585	100NF 10% X7R 0805 50V	+	+	+	+
2321	482212614585	100NF 10% X7R 0805 50V	+	+	+	+
2322	532212611579	3,3NF10%X7R 63V	+	+	+	+
2333	482212614305	100NF 10% X7R 16V 0603 CER2	+	+	+	+
2335	319801734730	CER2 0603 X7R 16V 47N COL	+	+	+	+
2336	482212614305	100NF 10% X7R 16V 0603 CER2	+	+	+	+
2337	482212614305	100NF 10% X7R 16V 0603 CER2	+	+	+	+
2355	482212614305	100NF 10% X7R 16V 0603 CER2	+	+	+	+
2359	482212613692	47PF 1% NP0 63V	+	+	+	+
2360	482212614305	100NF 10% X7R 16V 0603 CER2	+	+	+	+
2362	482212613751	47NF10% X7R 63V	+	+	+	+
2364	482212614585	100NF 10% X7R 0805 50V	+	+	+	+
2368	223886115182	CER1 0805 NP0 50V 1N8 PM5 R	+	+	+	+
2369	532212232268	470PF 10% 50V	+	+	+	+
2370	482212441796	22UF20% 16V	+	+	+	+
2371	482212614305	100NF 10% X7R 16V 0603 CER2	+	+	+	+
2372	532212232447	1PF 5% NP0 63V CASE 0805	+	+	+	+
2373	482212441796	22UF20% 16V	+	+	+	+
2374	482212614305	100NF 10% X7R 16V 0603 CER2	+	+	+	+
2375	482212614305	100NF 10% X7R 16V 0603 CER2	+	+	+	+
2378	482212614305	100NF 10% X7R 16V 0603 CER2	+	+	+	+
2379	482212613692	47PF 1% NP0 63V	+	+	+	+
2401	482212614585	100NF 10% X7R 0805 50V	+	+	+	-
2402	482205120008	0R00 JUMP. (0805)	+	+	+	+
2404	482212412245	ELCAP 10V 220U PM20	+	+	+	-
2405	482212614585	100NF 10% X7R 0805 50V	+	+	+	-
2406	532212411919	47UF 20% 6,3V	+	+	+	-
2407	482212614585	100NF 10% X7R 0805 50V	+	+	+	-
2408	532212411919	47UF 20% 6,3V	+	+	+	-
2409	482212614585	100NF 10% X7R 0805 50V	+	+	+	-
2411	319803074780	ELCAP SM 35V 4U7 PM20 COL R	+	+	+	-
2413	482212613838	100NF Y5V 0805 50V P80M20	+	+	+	-
2414	482212480483	47UF20% 6,3V	+	+	+	-
2415	482212614585	100NF 10% X7R 0805 50V	+	+	+	-
2417	319803074780	ELCAP SM 35V 4U7 PM20 COL R	+	+	+	-
2419	482212613838	100NF Y5V 0805 50V P80M20	+	+	+	-
2421	482212614585	100NF 10% X7R 0805 50V	+	+	+	-
2422	482212614585	100NF 10% X7R 0805 50V	+	+	+	-
2424	482212480483	47UF20% 6,3V	+	+	+	-
2425	482212233216	270PF 5%NP0 50V	+	+	-	-
2430	482212480483	47UF20% 6,3V	+	+	+	-
2431	482212233216	270PF 5%NP0 50V	+	-	-	-
2433	482212614585	100NF 10% X7R 0805 50V	+	-	-	-
2434	482212614585	100NF 10% X7R 0805 50V	+	+	+	-
2435	482212614585	100NF 10% X7R 0805 50V	+	+	+	-
2437	202002490264	ELCAP MA 4V S 470U PM20 A	+	+	+	-
2438	202002490264	ELCAP MA 4V S 470U PM20 A	+	+	+	-
2440	482212480483	47UF20% 6,3V	+	+	+	-
2441	482212480483	47UF20% 6,3V	+	+	+	-
2442	532212231647	1NF10%X7R 63V	+	+	+	-
2443	532212231647	1NF10%X7R 63V	+	+	+	-
2450	482212233216	270PF 5%NP0 50V	+	+	+	-
2451	482212233216	270PF 5%NP0 50V	+	+	+	-
2460	482212611663	12PF	+	+	+	-
2463	482212233926	12PF 50V	+	+	+	-
2464	482212611663	12PF	+	+	+	-

ITEM	CODENUMBER	DESCRIPTION	CDR775	CDR570	CDR770	CDR950
2465	482212611663	12PF	+	+	+	-
2500	482212614238	CER2 0603 X7R 50V 2N2 COL R	+	+	+	+
2501	482212614238	CER2 0603 X7R 50V 2N2 COL R	+	+	+	+
2502	482212614238	CER2 0603 X7R 50V 2N2 COL R	+	+	+	+
2504	482212412245		+	+	+	+
2505	482212412255	10UF 20% 50V	+	+	+	+
2506	482212612105	CER2 0805 X7R 50V 33NF PM5	+	+	+	+
2507	482212412255	10UF 20% 50V	+	+	+	+
2508	482212614585	100NF 10% X7R 0805 50V	+	+	+	+
2509	482212614585	100NF 10% X7R 0805 50V	+	+	+	+
2535	482212614585	100NF 10% X7R 0805 50V	+	+	+	+
2536	482212614585	100NF 10% X7R 0805 50V	+	+	+	+
2537	532212411919	47UF 20% 6,3V	+	+	+	+
2541	482212614305	100NF 10% X7R 16V 0603 CER2	+	+	+	+
2543	482212614585	100NF 10% X7R 0805 50V	+	+	+	+
2544	482212480483	47UF20% 6,3V	+	+	+	+
2546	482212480483	47UF20% 6,3V	+	+	+	+
2547	482212481286	47UF20% 16V	+	+	+	+
2548	482212441643	100UF 20% 16V DIM:6,3X11MM	+	+	+	+
2550	482212614585	100NF 10% X7R 0805 50V	+	+	+	+
2551	482212441796	22UF20% 16V	+	+	+	+
2552	532212231647	1NF10%X7R 63V	+	+	+	+
2553	482212614585	100NF 10% X7R 0805 50V	+	+	+	+
2555	482212233177	10NF 20% X7R 50V	+	+	+	+
2556	482212614305	100NF 10% X7R 16V 0603 CER2	+	+	+	+
2557	482212614305	100NF 10% X7R 16V 0603 CER2	+	+	+	+
2558	482212441584	100UF 20% 10V	+	+	+	+
2561	482212614585	100NF 10% X7R 0805 50V	+	+	+	+
2562	482212614585	100NF 10% X7R 0805 50V	+	+	+	+
2563	482212614585	100NF 10% X7R 0805 50V	+	+	+	+
2565	482212614305	100NF 10% X7R 16V 0603 CER2	+	+	+	+
2568	482212441643	100UF 20% 16V DIM:6,3X11MM	+	+	+	+
2571	482212614305	100NF 10% X7R 16V 0603 CER2	+	+	+	+
2572	482212614585	100NF 10% X7R 0805 50V	+	+	+	+
2574	482212614585	100NF 10% X7R 0805 50V	+	+	+	+
2575	482212412245	ELCAP 220U 16V 20%	+	+	+	+
2576	482212613838	100NF Y5V 0805 50V P80M20	+	+	+	+
2577	482212614305	100NF 10% X7R 16V 0603 CER2	+	+	+	+
2700	482212614585	100NF 10% X7R 0805 50V	+	+	+	+
2701	532212411919	47UF 20% 6,3V	+	+	+	+
2702	482212614585	100NF 10% X7R 0805 50V	+	+	+	+
2703	532212411919	47UF 20% 6,3V	+	+	+	+
2704	482212614585	100NF 10% X7R 0805 50V	+	+	+	+
2705	482212614585	100NF 10% X7R 0805 50V	+	+	+	+
2706	482212614585	100NF 10% X7R 0805 50V	+	+	+	+
2707	482212613692	47PF 1% NP0 63V	+	+	+	+
2708	482212613692	47PF 1% NP0 63V	+	+	+	+
2709	482212613692	47PF 1% NP0 63V	+	+	+	+
2710	532212411919	47UF 20% 6,3V	+	+	+	+
2711	482212614585	100NF 10% X7R 0805 50V	+	+	+	+
2712	482212612105	CER2 0805 X7R 50V 33NF PM5	+	+	+	+
2713	532212611583	10NF 10% X7R 50V 0603 CER2	+	+	+	+
2714	482212614549	33N 16V X7R O6O3	+	+	+	+
2715	482212614585	100NF 10% X7R 0805 50V	+	+	+	+
2716	532212611583	10NF 10% X7R 50V 0603 CER2	+	+	+	+
2717	319801741050	CER2 0603 Y5V 10V 1U COL R	+	+	+	+
2718	532211680853	560PF 5%NP0 63V	+	+	+	+
2719	532211680853	560PF 5%NP0 63V	+	+	+	+
2720	532212231647	1NF10%X7R 63V	+	+	+	+
2721	482212613692	47PF 1% NP0 63V	+	+	+	+
2722	482212613692	47PF 1% NP0 63V	+	+	+	+

ITEM	CODENUMBER	DESCRIPTION	CDR775	CDR570	CDR770	CDR950
2723	482212614585	100NF 10% X7R 0805 50V	+	+	+	+
2725	482212614585	100NF 10% X7R 0805 50V	+	+	+	+
2726	482212614585	100NF 10% X7R 0805 50V	+	+	+	+
2727	482212614585	100NF 10% X7R 0805 50V	+	+	+	+
2728	482212614585	100NF 10% X7R 0805 50V	+	+	+	+
2731	482212613692	47PF 1% NP0 63V	+	-	-	-
2733	482212233777	47PF 5%NP0 63V	+	-	-	-
2734	482212233777	47PF 5%NP0 63V	+	-	-	-
2735	482212233777	47PF 5%NP0 63V	+	-	-	-
2736	482212614305	100NF 10% X7R 16V 0603 CER2	+	-	-	-
2737	482212614305	100NF 10% X7R 16V 0603 CER2	+	-	-	-
2738	482212233777	47PF 5%NP0 63V	+	-	-	-
2739	482212233777	47PF 5%NP0 63V	+	-	-	-
2740	482212233777	47PF 5%NP0 63V	+	-	-	-
2741	482212233777	47PF 5%NP0 63V	+	-	-	-
2742	482212233777	47PF 5%NP0 63V	+	-	-	-
2743	482212233777	47PF 5%NP0 63V	+	-	-	-
2750	319801741050	CER2 0603 Y5V 10V 1U COL R	+	+	+	+
2751	482212614585	100NF 10% X7R 0805 50V	+	+	+	+
2752	482212614585	100NF 10% X7R 0805 50V	+	+	+	+
2760	482212614585	100NF 10% X7R 0805 50V	+	+	+	+
2761	482212614585	100NF 10% X7R 0805 50V	+	+	+	+
2762	482212612105	CER2 0805 X7R 50V 33NF PM5	+	+	+	+
2763	482212614585	100NF 10% X7R 0805 50V	+	+	+	+
2764	482212612105	CER2 0805 X7R 50V 33NF PM5	+	+	+	+
2765	482212612105	CER2 0805 X7R 50V 33NF PM5	+	+	+	+
2766	482212612105	CER2 0805 X7R 50V 33NF PM5	+	+	+	+
2901	319802190030	RST JUMPER 0603 0.05 OHM	+	+	+	+
2902	482205120008	0R00 JUMP. (0805)	+	+	+	+
2903	319802190030	RST JUMPER 0603 0.05 OHM	+	+	-	+
2904	319802190030	RST JUMPER 0603 0.05 OHM	+	+	+	+
2905	319802190030	RST JUMPER 0603 0.05 OHM	+	+	+	+
2906	482205120008	0R00 JUMP. (0805)	+	+	+	+
2907	482205120008	0R00 JUMP. (0805)	+	+	+	+
2908	319802190030	RST JUMPER 0603 0.05 OHM	+	+	+	+
2909	319801741050	CER2 0603 Y5V 10V 1U COL R	+	+	+	+
2910	482212412245	ELCAP 220U 16V 20%	+	+	+	+
3000	482205120101	100R00 5% 0,1W	+	+	+	+
3001	482211711151	1R 5%	+	+	+	+
3002	482205120122	1K20 5% 0,1W	+	+	+	+
3003	482205130121	120R00 5% 0,062W	+	+	+	+
3004	482205130121	120R00 5% 0,062W	+	+	+	+
3006	482205130008	0R00 JUMPER	+	+	+	+
3007	482205120154	150K00 5% 0,1W	+	+	+	+
3009	482205130681	680R00 5% 0,062W	+	+	+	+
3010	482205130681	680R00 5% 0,062W	+	+	+	+
3011	482205120829	82R00 5% 0,1W	+	+	+	+
3012	482205130154	150K00 5% 0,062W	+	+	+	+
3013	482205120105	1M00 5% 0,1W	+	+	+	+
3014	482211711139	1K5 1% 0,1W	+	+	+	+
3015	482211683933	15K 1% 0,1W	+	+	+	+
3016	482211713172	62K 1% RC12H 0805 0,1W	+	+	+	+
3017	482205130392	3K9 5% 0.063W 0603	+	+	+	+
3019	482205130105	1M00 5% 0,062W	+	+	+	+
3020	482211683933	15K 1% 0,1W	+	+	+	+
3021	482211683933	15K 1% 0,1W	+	+	+	+
3022	482211711456	30K 1% 0,1W	+	+	+	+
3023	482211713172	62K 1% RC12H 0805 0,1W	+	+	+	+
3024	482211711374	120K 1% RC12H 0805	+	+	+	+
3025	482211713569	240K 1% 0805 RC12H	+	+	+	+
3026	482205120474	470K00 5% 0,1W	+	+	+	+

ITEM	CODENUMBER	DESCRIPTION	CDR775	CDR570	CDR770	CDR950
3027	482211711456	30K 1% 0,1W	+	+	+	+
3028	482211713172	62K 1% RC12H 0805 0,1W	+	+	+	+
3029	482211711374	120K 1% RC12H 0805	+	+	+	+
3030	482211713569	240K 1% 0805 RC12H	+	+	+	+
3031	482205120474	470K00 5% 0,1W	+	+	+	+
3035	482211713571	910K 1% 0805 RC12H	+	+	+	+
3036	482211713571	910K 1% 0805 RC12H	+	+	+	+
3037	482211710833	10K 1% 0,1W	+	+	+	+
3039	482205130183	18K00 5% 0,062W	+	+	+	+
3040	482205130101	100R00 5% 0,062W	+	+	+	+
3041	482205130103	10K00 5% 0,062W	+	+	+	+
3043	482205130105	1M00 5% 0,062W	+	+	+	+
3044	482205120105	1M00 5% 0,1W	+	+	+	+
3048	482205130103	10K00 5% 0,062W	+	+	+	+
3049	482205110102	1K00 2% 0,25W	+	+	+	+
3050	482205130101	100R00 5% 0,062W	+	+	+	+
3051	482211712902	8K2 1% 0.063W 0603	+	+	+	+
3052	482211712902	8K2 1% 0.063W 0603	+	+	+	+
3053	482205130102	1K00 5% 0,062W	+	+	+	+
3054	482211711188	20K 1% 0,1W	+	+	+	+
3055	482205130102	1K00 5% 0,062W	+	+	+	+
3056	482205130102	1K00 5% 0,062W	+	+	+	+
3057	482205120472	4K70 5% 0,1W	+	+	+	+
3058	482205120154	150K00 5% 0,1W	+	+	+	+
3059	482205130682	6K80 5% 0,062W	+	+	+	+
3060	482205130103	10K00 5% 0,062W	+	+	+	+
3061	482205130102	1K00 5% 0,062W	+	+	+	+
3063	482211713572	22R 5% 1206	+	+	+	+
3064	482205130221	220R00 5% 0,062W	+	+	+	+
3065	482205120393	39K00 5% 0,1W	+	+	+	+
3066	482211712367	33K 1% 0.10W	+	+	+	+
3067	482205130102	1K00 5% 0,062W	+	+	+	+
3068	482205120472	4K70 5% 0,1W	+	+	+	+
3069	482205120392	3K90 5% 0,1W	+	+	+	+
3070	482205110102	1K00 2% 0,25W	+	+	+	+
3071	482205130222	2K20 5% 0,062W	+	+	+	+
3072	482205120472	4K70 5% 0,1W	+	+	+	+
3073	482205120472	4K70 5% 0,1W	+	+	+	+
3074	482211711151	1R 5%	+	+	+	+
3075	482205120154	150K00 5% 0,1W	+	+	+	+
3076	482205120154	150K00 5% 0,1W	+	+	+	+
3077	482205120154	150K00 5% 0,1W	+	+	+	+
3078	482205130102	1K00 5% 0,062W	+	+	+	+
3079	482211711751	16K RC12H 1% 0805	+	+	+	+
3081	482205110102	1K00 2% 0,25W	+	+	+	+
3082	482205130102	1K00 5% 0,062W	+	+	+	+
3085	482211713568	6R8 5% 1206	+	+	+	+
3086	482211711503	220R 1% 0.1W	+	+	+	+
3087	482205130222	2K20 5% 0,062W	+	+	+	+
3088	482205130152	1K50 5% 0,062W	+	+	+	+
3090	482205130479	47R00 5% 0,062W	+	+	+	+
3091	482211712903	1K8 1% 0.063W 0603	+	+	+	+
3092	482205130103	10K00 5% 0,062W	+	+	+	+
3094	482205130221	220R00 5% 0,062W	+	+	+	+
3095	482211713568	6R8 5% 1206	+	+	+	+
3097	482205130479	47R00 5% 0,062W	+	+	+	+
3098	482205130103	10K00 5% 0,062W	+	+	+	+
3100	482205120472	4K70 5% 0,1W	+	+	+	+
3101	482211713572	22R 5% 1206	+	+	+	+
3102	482211711148	56K 1% 0,1W	+	+	+	+
3103	482211710833	10K 1% 0,1W	+	+	+	+

ITEM	CODENUMBER	DESCRIPTION	CDR775	CDR570	CDR770	CDR950
3104	482211710833	10K 1% 0,1W	+	+	+	+
3105	482205120182	1K80 5% 0,1W	+	+	+	+
3106	482205130008	0R00 JUMPER	+	+	+	+
3107	482205130008	0R00 JUMPER	+	+	+	+
3110	482205130103	10K00 5% 0,062W	+	+	+	+
3111	482211712902	8K2 1% 0.063W 0603	+	+	+	+
3112	482205130479	47R00 5% 0,062W	+	+	+	+
3113	482211711503	220R 1% 0.1W	+	+	+	+
3114	482211713577	330R 1% RC12H 0805 1,25W	+	+	+	+
3115	482211712521	68R 1% 0,1W	+	+	+	+
3116	482211711817	1K2 1% 1/16W	+	+	+	+
3117	482205130103	10K00 5% 0,062W	+	+	+	+
3118	482205130561	560R00 5% 0,062W	+	+	+	+
3119	482205130221	220R00 5% 0,062W	+	+	+	+
3120	532211711726	10R 5%	+	+	+	+
3123	482205130472	4K70 5% 0,062W	+	+	+	+
3126	482205130682	6K80 5% 0,062W	+	+	+	+
3127	482211712903	1K8 1% 0.063W 0603	+	+	+	+
3128	482205130479	47R00 5% 0,062W	+	+	+	+
3129	482205130102	1K00 5% 0,062W	+	+	+	+
3130	482205130103	10K00 5% 0,062W	+	+	+	+
3131	482205130103	10K00 5% 0,062W	+	+	+	+
3200	482205120479	47R00 5% 0,1W	+	+	+	+
3201	482205120479	47R00 5% 0,1W	+	+	+	+
3202	482205120479	47R00 5% 0,1W	+	+	+	+
3203	482205120479	47R00 5% 0,1W	+	+	+	+
3204	482205120479	47R00 5% 0,1W	+	+	+	+
3205	482205120479	47R00 5% 0,1W	+	+	+	+
3206	482205120479	47R00 5% 0,1W	+	+	+	+
3207	482205120479	47R00 5% 0,1W	+	+	+	+
3208	482211710833	10K 1% 0,1W	+	+	+	+
3209	482215771206	BLM21A601SPT	+	+	+	+
3210	482211713573	NETW 4 X 47R 5% MNR14	+	+	+	+
3211	482211713573	NETW 4 X 47R 5% MNR14	+	+	+	+
3212	482211711503	220R 1% 0.1W	+	+	+	+
3213	482205130008	0R00 JUMPER	+	+	+	+
3215	482205130153	15K00 5% 0,062W	+	+	+	+
3216	482205130153	15K00 5% 0,062W	+	+	+	+
3217	482211712925	47K 1% 0.063W 0603	+	+	+	+
3218	482205130103	10K00 5% 0,062W	+	+	+	+
3219	482205130223	22K00 5% 0,062W	+	+	+	+
3220	482205130103	10K00 5% 0,062W	+	+	+	+
3221	482205130223	22K00 5% 0,062W	+	+	+	+
3222	482211713573	NETW 4 X 47R 5% MNR14	+	+	+	+
3223	482211713573	NETW 4 X 47R 5% MNR14	+	+	+	+
3224	482211711374	120K 1% RC12H 0805	+	+	+	+
3225	482211712367	33K 1% 0.10W	+	+	+	+
3226	482211710833	10K 1% 0,1W	+	+	+	+
3227	482211712367	33K 1% 0.10W	+	+	+	+
3228	482211710833	10K 1% 0,1W	+	+	+	+
3229	482211711374	120K 1% RC12H 0805	+	+	+	+
3230	482211713632	100K 1% 0603 0.62W	+	+	+	+
3231	482211713632	100K 1% 0603 0.62W	+	+	+	+
3232	482211710833	10K 1% 0,1W	+	+	+	+
3233	482205120101	100R00 5% 0,1W	+	+	+	+
3234	482205110102	1K00 2% 0,25W	+	+	+	+
3235	482211713573	NETW 4 X 47R 5% MNR14	+	+	+	+
3237	482205130562	5K6 5% 0,063W 0603 RC21 RST SM	+	+	+	+
3238	482205130221	220R00 5% 0,062W	+	+	+	+
3239	482205130102	1K00 5% 0,062W	+	+	+	+
3240	482205130103	10K00 5% 0,062W	+	+	+	+

ITEM	CODENUMBER	DESCRIPTION	CDR775	CDR570	CDR770	CDR950
3241	482205130008	OR00 JUMPER	+	+	+	+
3242	235003510103	RST NETW SM ARV24 4X10K PM5 R	+	+	+	+
3243	235003510103	RST NETW SM ARV24 4X10K PM5 R	+	+	+	+
3244	482205130008	OR00 JUMPER	+	+	+	+
3245	482205130221	220R00 5% 0,062W	+	+	+	+
3246	482205130221	220R00 5% 0,062W	+	+	+	+
3248	482211713523	220R 5% RESN 0.63W	+	+	+	+
3249	482211711503	220R 1% 0.1W	+	+	+	+
3252	482211711145	4K70 1% 0,1W	+	+	+	+
3253	482211711145	4K70 1% 0,1W	+	+	+	+
3254	482205130008	OR00 JUMPER	+	+	+	+
3255	482211710833	10K 1% 0,1W	+	+	+	+
3256	482205130008	OR00 JUMPER	+	+	+	+
3260	482205130008	OR00 JUMPER	+	+	+	+
3261	482205130222	2K20 5% 0,062W	+	+	+	+
3265	482205130008	OR00 JUMPER	+	+	+	+
3271	482211713573	NETW 4 X 47R 5% MNR14	+	+	+	+
3273	482211713573	NETW 4 X 47R 5% MNR14	+	+	+	+
3274	482211710837	100K 1% 0.1W	+	+	+	+
3276	482205130479	47R00 5% 0,062W	+	+	+	+
3280	482205130479	47R00 5% 0,062W	+	+	+	+
3281	482211713579	220K 1% 0.1W RC12H 0805	+	+	+	+
3284	482211711151	1R 5%	+	+	+	+
3286	482205130223	22K00 5% 0,062W	+	+	+	+
3287	482205130103	10K00 5% 0,062W	+	+	+	+
3288	482205130563	56K00 5% 0,062W	+	+	+	+
3289	482205130563	56K00 5% 0,062W	+	+	+	+
3290	482205130683	68K00 5% 0,062W	+	+	+	+
3291	482205130563	56K00 5% 0,062W	+	+	+	+
3295	482205130332	3K30 5% 0,062W	+	+	+	+
3297	482205130332	3K30 5% 0,062W	+	+	+	+
3299	482205130332	3K30 5% 0,062W	+	+	+	+
3300	482205110102	1K00 2% 0,25W	+	+	+	+
3301	482205110102	1K00 2% 0,25W	+	+	+	+
3303	482211713572	22R 5% 1206	+	+	+	+
3305	482211710833	10K 1% 0,1W	+	+	+	+
3308	482205120008	OR00 JUMP. (0805)	+	+	+	+
3309	482211712367	33K 1% 0.10W	+	+	+	+
3312	482205130479	47R00 5% 0,062W	+	+	+	+
3313	482205130479	47R00 5% 0,062W	+	+	+	+
3314	482205120479	47R00 5% 0,1W	+	+	+	+
3315	482205130102	1K00 5% 0,062W	+	+	+	+
3316	482205120472	4K70 5% 0,1W	+	+	+	+
3317	482205120472	4K70 5% 0,1W	+	+	+	+
3319	482205120479	47R00 5% 0,1W	+	+	+	+
3322	482205130102	1K00 5% 0,062W	+	+	+	+
3323	482205130562	5K6 5% 0,063W 0603 RC21 RST SM	+	+	+	+
3324	482205130562	5K6 5% 0,063W 0603 RC21 RST SM	+	+	+	+
3325	482205130103	10K00 5% 0,062W	+	+	+	+
3333	482211713574	1R5 5% 1206	+	+	+	+
3334	482211713574	1R5 5% 1206	+	+	+	+
3335	482211713574	1R5 5% 1206	+	+	+	+
3337	482205130563	56K00 5% 0,062W	+	+	+	+
3338	532211712487	1K RC12G 1% 0,125W	+	+	+	+
3339	532211712487	1K RC12G 1% 0,125W	+	+	+	+
3340	482211713632	100K 1% 0603 0.62W	+	+	+	+
3341	232273468209	RST SM 0805 RC12H 82R PM1	+	+	+	+
3346	482211711507	6K8 1% 0,1W	+	+	+	+
3347	482211711507	6K8 1% 0,1W	+	+	+	+
3348	482211711507	6K8 1% 0,1W	+	+	+	+
3349	482211713632	100K 1% 0603 0.62W	+	+	+	+

ITEM	CODENUMBER	DESCRIPTION	CDR775	CDR570	CDR770	CDR950
3350	232273468209	RST SM 0805 RC12H 82R PM1	+	+	+	+
3351	482211711151	1R 5%	+	+	+	+
3352	482205130008	0R00 JUMPER	+	+	+	+
3360	482211710354	22K 1% 0,1W	+	+	+	+
3361	482211712139	22R 5% 0,062W	+	+	+	+
3362	482211712708	39K 1% 0,1W 0805 RC12G	+	+	+	+
3363	482211712968	820R 5% 0,62W	+	+	+	+
3365	482205130101	100R00 5% 0,062W	+	+	+	+
3368	482205130479	47R00 5% 0,062W	+	+	+	+
3370	482205130561	560R00 5% 0,062W	+	+	+	+
3371	482205130152	1K50 5% 0,062W	+	+	+	+
3372	482205120122	1K20 5% 0,1W	+	+	+	+
3373	482211712903	1K8 1% 0.063W 0603	+	+	+	+
3374	482211713572	22R 5% 1206	+	+	+	+
3375	482205130222	2K20 5% 0,062W	+	+	+	+
3376	482205130221	220R00 5% 0,062W	+	+	+	+
3377	482205130479	47R00 5% 0,062W	+	+	+	+
3378	482205130273	27K00 5% 0,062W	+	+	+	+
3379	482205130183	18K00 5% 0,062W	+	+	+	+
3381	482205120008	0R00 JUMP. (0805)	+	+	+	+
3382	482211713573	NETW 4 X 47R 5% MNR14	+	+	+	+
3402	482211711503	220R 1% 0.1W	+	+	+	-
3403	482211712024	27K 1% 0.1W	+	+	+	-
3404	482211710833	10K 1% 0,1W	+	+	+	-
3405	482211712024	27K 1% 0.1W	+	+	+	-
3407	482205120101	100R00 5% 0,1W	+	+	+	-
3408	482211710833	10K 1% 0,1W	+	+	+	-
3409	482211712367	33K 1% 0.10W	+	+	+	-
3410	482211710833	10K 1% 0,1W	+	+	+	-
3411	482211711152	4R7 5%	+	+	+	-
3412	482211712024	27K 1% 0.1W	+	+	+	-
3413	482211710833	10K 1% 0,1W	+	+	+	-
3414	482211712024	27K 1% 0.1W	+	+	+	-
3415	482211710833	10K 1% 0,1W	+	+	+	-
3416	482211712367	33K 1% 0.10W	+	+	+	-
3418	482205120008	0R00 JUMP. (0805)	+	+	+	-
3420	482211710833	10K 1% 0,1W	+	+	+	-
3421	482211711383	12K 1% 0,1W	+	+	+	-
3422	482211710834	47K 1% 0,1W	+	+	+	-
3423	482211713629	120R 1% 0.1W RC12H 0805	+	-	+	-
3424	482205120225	2M20 5% 0,1W	+	-	+	-
3427	482211713629	120R 1% 0.1W RC12H 0805	+	-	+	-
3428	482205120225	2M20 5% 0,1W	+	-	+	-
3429	482211710834	47K 1% 0,1W	+	+	+	-
3432	482211710833	10K 1% 0,1W	+	+	+	-
3433	482205120008	0R00 JUMP. (0805)	+	+	+	-
3435	482211710833	10K 1% 0,1W	+	+	+	-
3436	482211711383	12K 1% 0,1W	+	+	+	-
3439	482211711152	4R7 5%	+	+	+	-
3441	482205120101	100R00 5% 0,1W	+	+	+	-
3447	482205120008	0R00 JUMP. (0805)	-	+	+	-
3448	482205120008	0R00 JUMP. (0805)	-	+	+	-
3449	482205120008	0R00 JUMP. (0805)	-	+	+	-
3450	319802153311	330R 5%	+	-	-	-
3451	482211711383	12K 1% 0,1W	+	+	+	-
3452	482211711383	12K 1% 0,1W	+	+	+	-
3453	482211713579	220K 1% 0.1W RC12H 0805	+	+	+	-
3454	482211713579	220K 1% 0.1W RC12H 0805	+	+	+	-
3455	319802190030	RST JUMPER 0603 0.05 OHM	+	+	+	-
3460	319802190030	RST JUMPER 0603 0.05 OHM	+	+	+	-
3531	482205120562	5K6 5% 0,1W 0805	+	+	+	+

ITEM	CODENUMBER	DESCRIPTION	CDR775	CDR570	CDR770	CDR950
3532	482205120562	5K6 5% 0,1W 0805	+	+	+	+
3533	482211710837	100K 1% 0,1W	+	+	+	+
3536	482211710837	100K 1% 0,1W	+	+	+	+
3537	482211710833	10K 1% 0,1W	+	+	+	+
3538	482211710833	10K 1% 0,1W	+	+	+	+
3539	482211710837	100K 1% 0,1W	+	+	+	+
3540	482211710833	10K 1% 0,1W	+	+	+	+
3541	482211711747	12R 1206 5% FUSE	+	+	+	+
3542	482211711747	12R 1206 5% FUSE	+	+	+	+
3544	482211710834	47K 1% 0,1W	+	+	+	+
3545	482211713568	6R8 5% 1206	+	+	+	+
3546	482205120101	100R00 5% 0,1W	+	+	+	+
3547	482211683933	15K 1% 0,1W	+	+	+	+
3548	482211710834	47K 1% 0,1W	+	+	+	+
3549	482205120101	100R00 5% 0,1W	+	+	+	+
3550	482205120101	100R00 5% 0,1W	+	+	+	+
3551	482205120332	3K30 5% 0,1W	+	+	+	+
3552	482211710834	47K 1% 0,1W	+	+	+	+
3553	482205120101	100R00 5% 0,1W	+	+	+	+
3554	482211710833	10K 1% 0,1W	+	+	+	+
3555	482205120122	1K20 5% 0,1W	+	+	+	+
3556	482211710833	10K 1% 0,1W	+	+	+	+
3557	482211710837	100K 1% 0,1W	+	+	+	+
3559	482205120562	5K6 5% 0,1W 0805	+	+	+	+
3560	482211710837	100K 1% 0,1W	+	+	+	+
3562	482205120562	5K6 5% 0,1W 0805	+	+	+	+
3563	482205130563	56K00 5% 0,062W	+	+	+	+
3566	482211710837	100K 1% 0,1W	+	+	+	+
3567	482205120223	22K00 5% 0,1W	+	+	+	+
3570	482205120101	100R00 5% 0,1W	+	+	+	+
3701	482205120101	100R00 5% 0,1W	+	+	+	+
3702	482205130472	4K70 5% 0,062W	+	+	+	+
3703	482205130472	4K70 5% 0,062W	+	+	+	+
3704	482205120008	0R00 JUMP. (0805)	+	+	+	+
3705	482205130223	22K00 5% 0,062W	+	+	+	+
3706	482205120479	47R00 5% 0,1W	+	+	+	+
3708	482205120479	47R00 5% 0,1W	+	+	+	+
3710	482205130101	100R00 5% 0,062W	+	+	+	+
3711	482211710833	10K 1% 0,1W	+	+	+	+
3712	482211710833	10K 1% 0,1W	+	+	+	+
3713	482205120479	47R00 5% 0,1W	+	+	+	+
3714	482205120479	47R00 5% 0,1W	+	+	+	+
3715	482205120479	47R00 5% 0,1W	+	+	+	+
3716	482211710833	10K 1% 0,1W	+	+	+	+
3717	482211710833	10K 1% 0,1W	-	+	+	+
3718	482211710833	10K 1% 0,1W	+	+	+	-
3719	482205130103	10K00 5% 0,062W	+	+	-	+
3720	482205130101	100R00 5% 0,062W	+	+	+	+
3721	482205130101	100R00 5% 0,062W	+	+	+	+
3722	482211710833	10K 1% 0,1W	+	-	-	-
3723	482211710833	10K 1% 0,1W	-	-	-	+
3724	482205130103	10K00 5% 0,062W	+	-	+	-
3725	482205130101	100R00 5% 0,062W	+	+	+	+
3726	482205130103	10K00 5% 0,062W	+	+	+	+
3727	482205120105	1M00 5% 0,1W	+	+	+	+
3728	482205130101	100R00 5% 0,062W	+	+	+	+
3729	482205130101	100R00 5% 0,062W	+	+	+	+
3731	482205130391	390R00 5% 0,062W	+	+	+	+
3732	482205130479	47R00 5% 0,062W	+	+	+	+
3735	482205120479	47R00 5% 0,1W	+	+	+	+
3742	482205130102	1K00 5% 0,062W	+	+	+	+

ITEM	CODENUMBER	DESCRIPTION	CDR775	CDR570	CDR770	CDR950
3743	482205130479	47R00 5% 0,062W	+	+	+	+
3744	482205120274	270K00 5% 0,1W	+	+	+	+
3745	482205120274	270K00 5% 0,1W	+	+	+	+
3746	482205130153	15K00 5% 0,062W	+	+	+	+
3747	482205130103	10K00 5% 0,062W	+	+	+	+
3748	482205130103	10K00 5% 0,062W	+	+	+	+
3749	482205130103	10K00 5% 0,062W	+	+	+	+
3750	482205130123	12K00 5% 0,062W	+	+	+	+
3751	482205120472	4K70 5% 0,1W	+	-	-	-
3752	482211710353	150R 1% 0,1W	+	+	+	+
3753	482205120472	4K70 5% 0,1W	+	-	-	-
3754	482205110102	1K00 2% 0,25W	+	+	+	+
3755	482211710353	150R 1% 0,1W	+	+	+	+
3756	482205130101	100R00 5% 0,062W	+	+	+	+
3757	482205120479	47R00 5% 0,1W	+	-	-	-
3758	482205120101	100R00 5% 0,1W	+	+	+	+
3759	482205110102	1K00 2% 0,25W	+	+	+	+
3760	482205120472	4K70 5% 0,1W	+	+	+	+
3761	482205130472	4K70 5% 0,062W	+	+	+	+
3762	482205130472	4K70 5% 0,062W	+	+	+	+
3763	482205130102	1K00 5% 0,062W	+	+	+	+
3764	482205120472	4K70 5% 0,1W	+	+	+	+
3766	482205130472	4K70 5% 0,062W	+	+	+	+
3767	482205130472	4K70 5% 0,062W	+	+	+	+
3768	482205120472	4K70 5% 0,1W	+	+	+	+
3769	482205130472	4K70 5% 0,062W	+	+	+	+
3770	482205120472	4K70 5% 0,1W	+	+	+	+
3771	482205130101	100R00 5% 0,062W	+	+	+	+
3780	482211710837	100K 1% 0,1W	+	+	+	+
3806	482205130103	10K00 5% 0,062W	+	+	+	+
3807	482205120008	0R00 JUMP. (0805)	+	+	+	+
3808	482211713573	NETW 4 X 47R 5% MNR14	+	+	+	+
3809	482211713573	NETW 4 X 47R 5% MNR14	+	+	+	+
3810	482205130472	4K70 5% 0,062W	+	+	+	+
3811	482205130103	10K00 5% 0,062W	+	+	+	+
3813	482205130101	100R00 5% 0,062W	+	+	+	+
3814	482205130479	47R00 5% 0,062W	+	+	+	+
3817	482205110102	1K00 2% 0,25W	+	+	+	+
3818	482211713573	NETW 4 X 47R 5% MNR14	+	+	+	+
3819	482211713573	NETW 4 X 47R 5% MNR14	+	+	+	+
3820	482211713573	NETW 4 X 47R 5% MNR14	+	+	+	+
3821	482211713573	NETW 4 X 47R 5% MNR14	+	+	+	+
3822	482211713573	NETW 4 X 47R 5% MNR14	+	+	+	+
3823	482211713573	NETW 4 X 47R 5% MNR14	+	+	+	+
3824	482211713573	NETW 4 X 47R 5% MNR14	+	+	+	+
3825	482211713573	NETW 4 X 47R 5% MNR14	+	+	+	+
3826	482205120101	100R00 5% 0,1W	+	+	+	+
3828	482205130479	47R00 5% 0,062W	+	-	-	-
3829	482205130479	47R00 5% 0,062W	+	-	-	-
3830	482205130479	47R00 5% 0,062W	+	-	-	-
3831	482205130479	47R00 5% 0,062W	+	-	-	-
3832	482205130479	47R00 5% 0,062W	+	-	-	-
3833	482205130479	47R00 5% 0,062W	+	-	-	-
3834	482205130479	47R00 5% 0,062W	+	-	-	-
3835	482205130479	47R00 5% 0,062W	+	-	-	-
3836	482205130479	47R00 5% 0,062W	+	-	-	-
3837	482211710833	10K 1% 0,1W	+	+	+	+
3838	482211710833	10K 1% 0,1W	+	+	+	+
3841	482205120101	100R00 5% 0,1W	+	+	+	+
3843	482211710833	10K 1% 0,1W	+	+	+	+
3844	482211710833	10K 1% 0,1W	+	+	+	+

ITEM	CODENUMBER	DESCRIPTION	CDR775	CDR570	CDR770	CDR950
3845	482211710833	10K 1% 0,1W	+	+	+	+
3886	482205120008	0R00 JUMP. (0805)	-	+	+	-
3889	482211711151	1R 5%	+	+	+	+
3891	482211710833	10K 1% 0,1W	+	+	+	-
3892	482211710833	10K 1% 0,1W	+	+	+	-
3894	482211713573	NETW 4 X 47R 5% MNR14	+	+	+	+
3897	482211713573	NETW 4 X 47R 5% MNR14	+	+	+	+
3898	482211713573	NETW 4 X 47R 5% MNR14	+	+	+	+
3900	319802190030	RST JUMPER 0603 0.05 OHM	-	-	-	+
3902	319802190030	RST JUMPER 0603 0.05 OHM	-	-	-	+
3903	482205130008	0R00 JUMPER	+	+	+	+
3904	482205110102	1K00 2% 0,25W	-	+	-	+
3906	482205120472	4K70 5% 0,1W	+	+	+	+
3907	482205130472	4K70 5% 0,062W	+	+	+	+
3908	482205130102	1K00 5% 0,062W	+	+	+	+
3909	482205130472	4K70 5% 0,062W	+	+	+	+
3910	482205120472	4K70 5% 0,1W	+	+	+	+
3911	482205120472	4K70 5% 0,1W	+	+	+	+
5008	482215771206	BLM21A601SPT	+	+	+	+
5201	482215771206	BLM21A601SPT	+	+	+	+
5202	482215771206	BLM21A601SPT	+	+	+	+
5203	482215771206	BLM21A601SPT	+	+	+	+
5301	482215771206	BLM21A601SPT	+	+	+	+
5302	482215771206	BLM21A601SPT	+	+	+	+
5303	482215771206	BLM21A601SPT	+	+	+	+
5401	482215771206	BLM21A601SPT	+	+	+	-
5403	482215771206	BLM21A601SPT	+	+	+	-
5404	482215771206	BLM21A601SPT	+	+	+	-
5406	482215771206	BLM21A601SPT	+	+	+	-
5407	482215771206	BLM21A601SPT	+	+	+	-
5413	482215771206	BLM21A601SPT	+	+	+	-
5414	482215771206	BLM21A601SPT	+	+	+	-
5500	482215711716	BLM21P300SPT	+	+	+	+
5501	242254942103	IND FXD SM EMI 100MHZ 2K2 R	+	+	+	+
5502	242254942103	IND FXD SM EMI 100MHZ 2K2 R	+	+	+	+
5503	242254942103	IND FXD SM EMI 100MHZ 2K2 R	+	+	+	+
5541	242254942103	IND FXD SM EMI 100MHZ 2K2 R	+	+	+	+
5542	242254942103	IND FXD SM EMI 100MHZ 2K2 R	+	+	+	+
5543	482215711716	BLM21P300SPT	+	+	+	+
5544	482215711716	BLM21P300SPT	+	+	+	+
5546	482215771206	BLM21A601SPT	+	+	+	+
5551	482215771206	BLM21A601SPT	+	+	+	+
5554	482215710548	47UH 5%	+	+	+	+
5555	482215771206	BLM21A601SPT	+	+	+	+
5556	482215771206	BLM21A601SPT	+	+	+	+
5557	482215771206	BLM21A601SPT	+	+	+	+
5701	482215771206	BLM21A601SPT	+	+	+	+
5709	242254942103	IND FXD SM EMI 100MHZ 2K2 R	+	+	+	+
5710	482215710477	COIL 47UH	+	+	+	+
5712	482215771206	BLM21A601SPT	+	+	+	+
5713	482215771206	BLM21A601SPT	+	+	+	+
5715	482215771206	BLM21A601SPT	+	+	+	+
5716	482215771206	BLM21A601SPT	+	+	+	+
6002	532213030691	BAW56	+	+	+	+
6003	482213083757	BAS216	+	+	+	+
6007	532213034337	BAV99	+	+	+	+
6373	482213083757	BAS216	+	+	+	+
6374	482213083757	BAS216	+	+	+	+
6375	482213083757	BAS216	+	+	+	+
6400	482213010648	BZX284-C5V6	+	-	-	-
6500	532213083777	BAV70W	+	+	+	+

ITEM	CODENUMBER	DESCRIPTION	CDR775	CDR570	CDR770	CDR950
6501	532213034337	BAV99	+	+	+	+
6502	482213034441	BZX79-B22	+	+	+	+
6553	482213083757	BAS216	+	+	+	+
6554	532213034337	BAV99	+	+	+	+
6555	482213083757	BAS216	+	+	+	+
6556	482213083757	BAS216	+	+	+	+
6557	482213083757	BAS216	+	+	+	+
6701	934042250135	DIO VAR SM BB147 (PHSE) R	+	+	+	+
6702	934042250135	DIO VAR SM BB147 (PHSE) R	+	+	+	+
7001	482220963709	LM324DTR	+	+	+	+
7002	482220963709	LM324DTR	+	+	+	+
7005	482220990331	TL084CDT	+	+	+	+
7008	482220917223	EFM TIM3	+	+	+	+
7010	935261972518	IC SM TZA1020HP/M1 (PHSE) R	+	+	+	+
7016	482220917225	M62364FP	+	+	+	+
7050	482220990331	TL084CDT	+	+	+	+
7104	482213060373	BC856B	+	+	+	+
7110	482213060511	BC847B	+	+	+	+
7111	482213060511	BC847B	+	+	+	+
7112	482213042804	BC817-25	+	+	+	+
7113	482213060511	BC847B	+	+	+	+
7119	482213060383	BF824	+	+	+	+
7120	482213060383	BF824	+	+	+	+
7121	532213060123	BC807-40	+	+	+	+
7122	532213060123	BC807-40	+	+	+	+
7124	482213060511	BC847B	+	+	+	+
7126	933714420653	IC SM 74HC4066D	+	+	+	+
7127	482213060373	BC856B	+	+	+	+
7133	482213060511	BC847B	+	+	+	+
7135	532213060123	BC807-40	+	+	+	+
7201	482213060511	BC847B	+	+	+	+
7202	482213060511	BC847B	+	+	+	+
7207	932213040668	IC SM M24C16-WMN (ST00) R	+	+	+	+
7208	310412394850	FLASH EPROM ASSY CDR-AUDIO	+	+	+	+
7209	482220917227	MC74LCX573	+	+	+	+
7215	482220932073	MC34072D	+	+	+	+
7225	532220971553	NE532D	+	+	+	+
7240	482220917229	BA5938FM	+	+	+	+
7270	482220917231	SAA7399HL	+	+	+	+
7300	935263368557	IC SM SAA7392HL/M3 (PHSE) Y	+	+	+	+
7330	482220916877	BA6856FP	+	+	+	+
7355	933713370653	IC SM 74HCT00D (PHSE) R	+	+	+	+
7360	933715300118	IC SM 74HCT4051D (PHSE) R	+	+	+	+
7361	482213060511	BC847B	+	+	+	+
7370	482213060511	BC847B	+	+	+	+
7371	482213011527	BFS540	+	+	+	+
7373	482213011527	BFS540	+	+	+	+
7375	482213011527	BFS540	+	+	+	+
7401	482220960792	74HC4053D	+	-	-	-
7405	482220930095	LM833D	+	+	+	-
7406	935254530118	IC SM UDA1341TS/N1 (PHSE) R	+	+	+	-
7407	482220960792	74HC4053D	+	-	-	-
7408	482220982362	NJM4556D	+	-	+	-
7409	482220930095	LM833D	+	+	+	-
7410	482213042804	BC817-25	+	-	+	-
7411	482213042804	BC817-25	+	-	+	-
7520	820405604480	FET POW STD16NE06L	+	+	+	+
7521	482220932073	MC34072D	+	+	+	+
7522	482213060373	BC856B	+	+	+	+
7523	482213060511	BC847B	+	+	+	+
7524	482213060511	BC847B	+	+	+	+

ITEM	CODENUMBER	DESCRIPTION	CDR775	CDR570	CDR770	CDR950
7525	482213060373	BC856B	+	+	+	+
7526	482213060511	BC847B	+	+	+	+
7527	482213011379	BCP69	+	+	+	+
7528	482213060511	BC847B	+	+	+	+
7529	482213060373	BC856B	+	+	+	+
7535	482220917398	LD1117DT33	+	+	+	+
7548	482213060511	BC847B	+	+	+	+
7549	482213060511	BC847B	+	+	+	+
7556	482220990332	MC79L05ABD	+	+	+	+
7558	482220915083	AN78M09	+	+	+	+
7560	482213060373	BC856B	+	+	+	+
7561	482213060373	BC856B	+	+	+	+
7562	482213060511	BC847B	+	+	+	+
7563	482213060511	BC847B	+	+	+	+
7701	820405603460	USER PROCESSOR DASP CF5244PU	+	+	+	+
7702	482220917375	GM71V18163CJ-6	+	+	+	+
7703	932213814668	IC SM AM29LV800BB-70REC (AMD)R	+	+	+	+
7704	482220916318	MC33464-30A	+	+	+	+
7705	482220932073	MC34072D	+	+	+	+
7706	482220917236	74LV74D	+	+	+	+
7707	482213060511	BC847B	+	-	-	-
7708	932214178668	IC SM 74LCX00M (ST00) R	+	+	+	+
7710	932213967685	IC SM MC33464N-45A (MOTA) R	+	+	+	+
7801	820405603520	LEVEL DIG POTMETER DS1807S-T/R	+	+	+	-
7802	820405603910	IC SM CY7C199-15ZC	+	+	+	+
7803	482213060511	BC847B	+	+	+	+
7804	482213060511	BC847B	+	+	+	+
PCINT-DASP	710408691110	PC-INTERFACE BOARD DASP	+	+	+	+
PCINT-MACE	710408683110	PC-INTERFACE BOARD MACE	+	+	+	+

6. Block diagrams

CDR MAIN BOARD BLOCK DIAGRAM

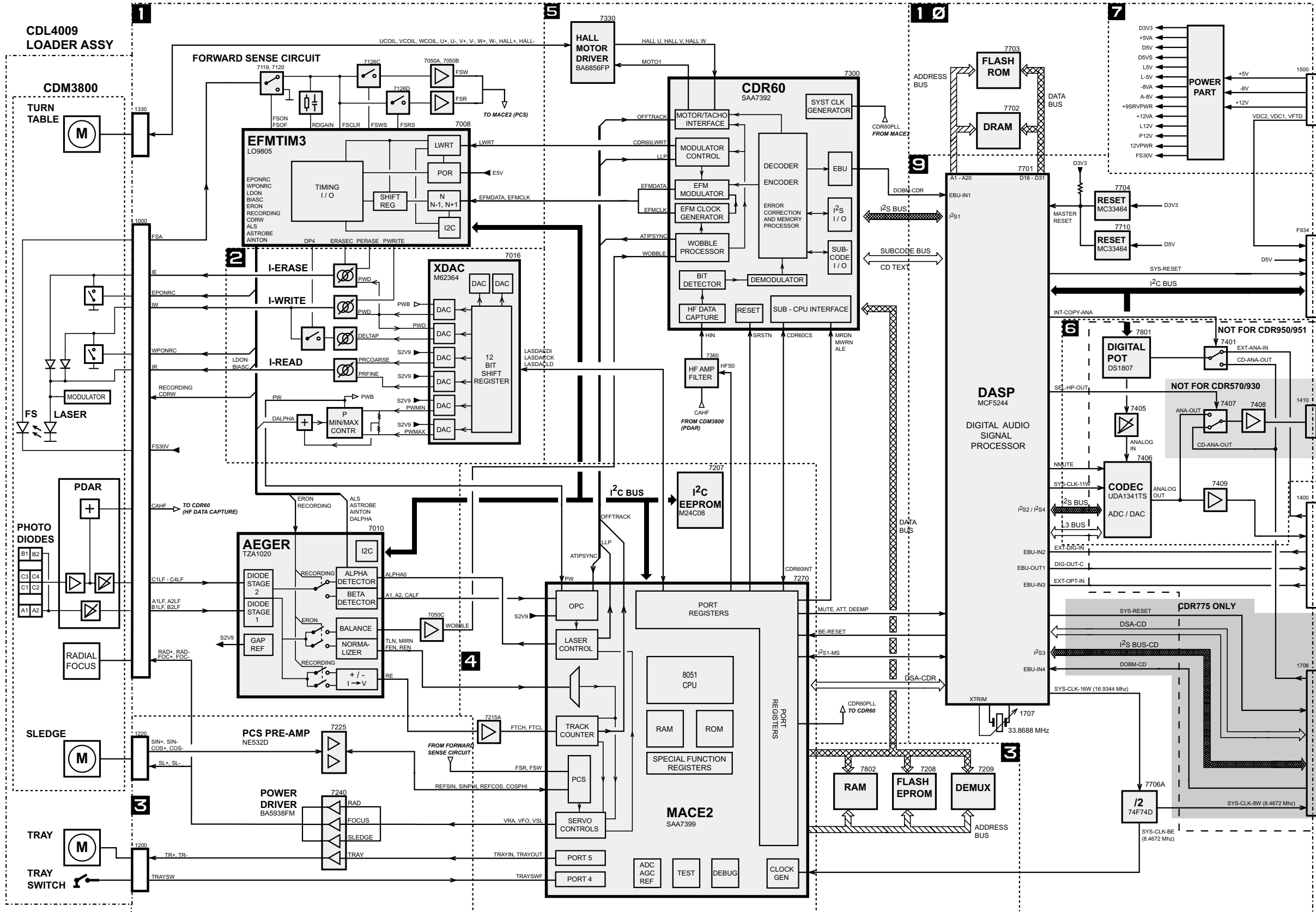

CDR MAIN BOARD - CIRCUIT DIAGRAM 3 : SERVO DRIVERS, MACE-RAM, -FLASH, -DEMUX TEST POINTS

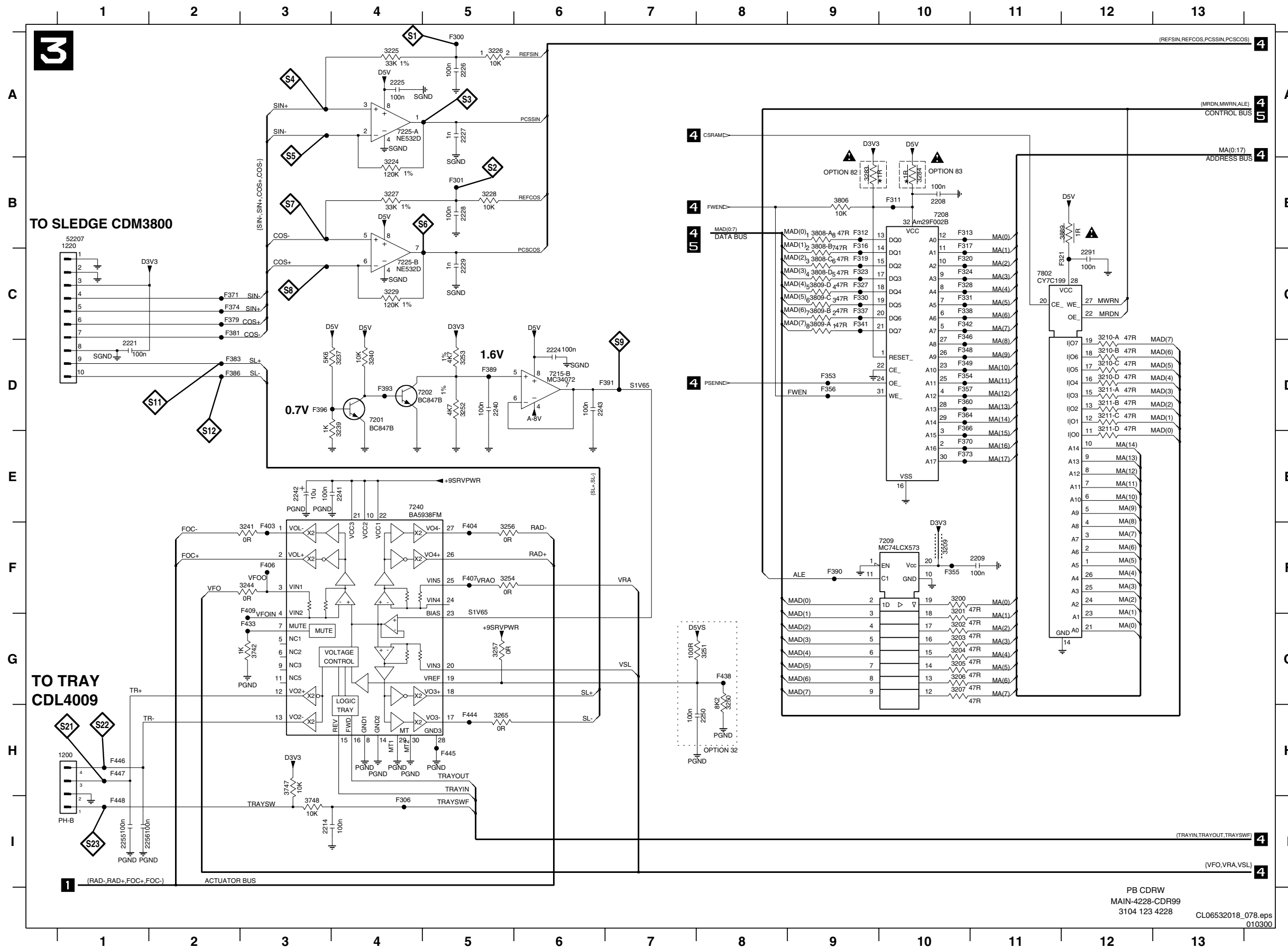

- F383 D2
- F386 D2
- F389 D5
- F390 F9
- F391 D7
- F393 D4
- F396 D3
- F403 F3
- F404 F5
- F406 F3
- F407 F5
- F409 F3
- F433 G3
- F438 G8
- F444 H5
- F445 H5
- F446 H1
- F447 H1
- F448 H1
- F383 D2
- F386 D2
- F389 D5
- F390 F9
- F391 D7
- F393 D4
- F396 D3
- F403 F3
- F404 F5
- F406 F3
- F407 F5
- F409 F3
- F433 G3
- F438 G8
- F444 H5
- F445 H5
- F446 H1
- F447 H1
- F448 H1

CDR MAIN BOARD - CIRCUIT DIAGRAM 4 : MACE BE-PROCESSOR TESTPOINTS

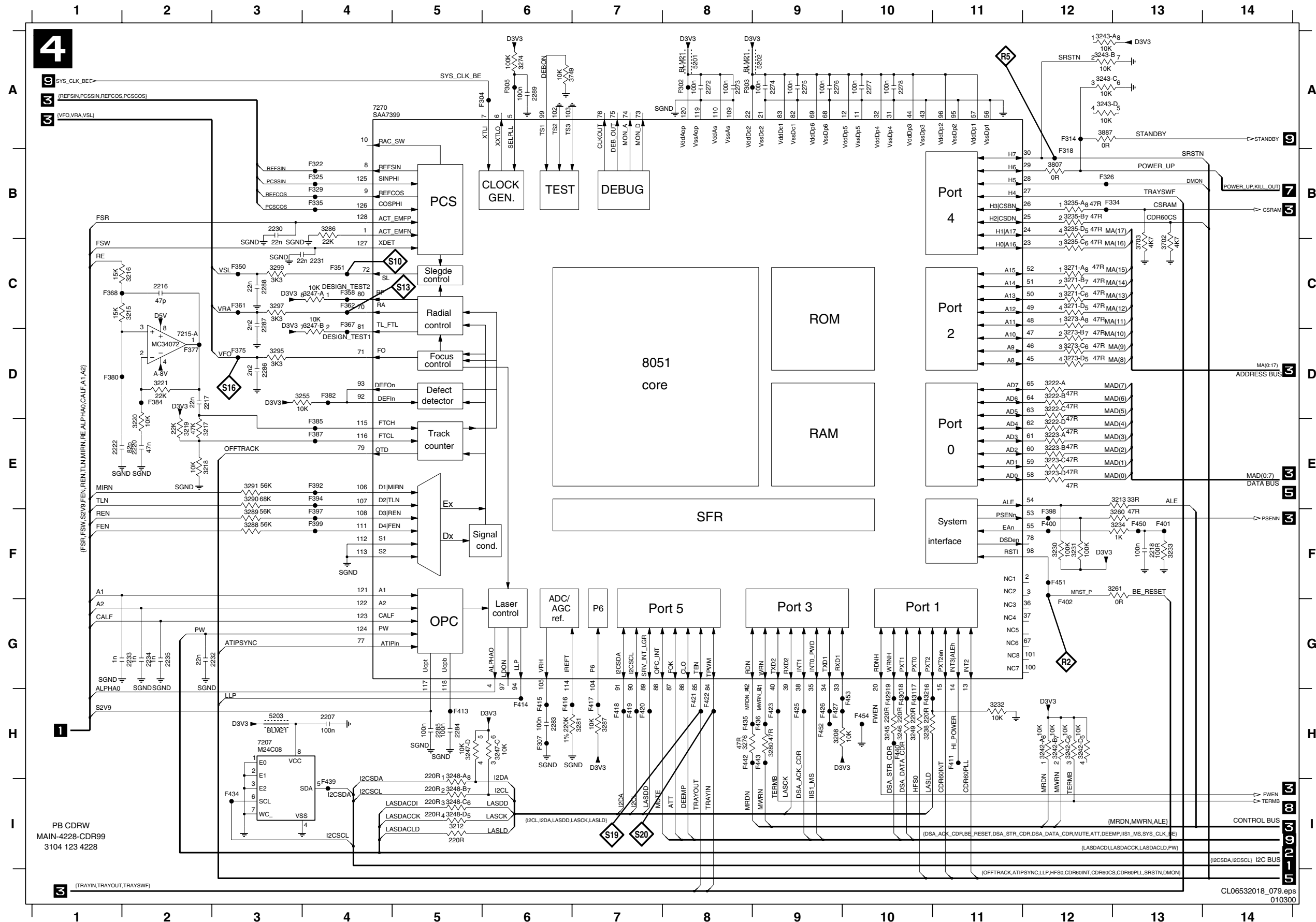

2207 H4	F325 B4
2216 C2	F326 B12
2217 D2	F329 B4
2218 G12	F334 B12
2220 E2	F335 B4
2222 E1	F350 C3
2230 B3	F351 C4
2231 C4	F358 C4
2232 G2	F361 C3
2233 G2	F362 C4
2234 G2	F367 C4
2235 G2	F368 C1
2272 A8	F375 D3
2273 A8	F377 D2
2274 A9	F380 D1
2275 A9	F382 D4
2276 A9	F384 D2
2277 A10	F385 E4
2278 A10	F387 E4
2283 H6	F392 E4
2284 H5	F394 E4
2285 H5	F397 F4
2286 D3	F398 F12
2287 C3	F399 F4
2288 C3	F400 F12
2289 A6	F401 G12
3208 H9	F402 F12
3212 I5	F411 H11
3213 E12	F413 H5
3215 C2	F414 H6
3216 C2	F415 H6
3217 E2	F416 H6
3218 E2	F417 H7
3219 E2	F418 H7
3220 E2	F419 H7
3221 D2	F420 H7
3222-A D12	F421 H8
3222-B D12	F422 H8
3222-C D12	F423 H9
3222-D E12	F425 H9
3223-A E12	F426 H9
3223-B E12	F427 H9
3223-C E12	F429 H10
3223-D E12	F430 H10
3230 G12	F431 H10
3231 G12	F432 H10
3232 H11	F434 I3
3233 G12	F435 H8
3234 G12	F436 H9
3235-A B12	F438 I4
3235-B B12	F440 H10
3235-C C12	F442 H8
3235-D B12	F443 H9
3238 H10	
3240-A H12	
3242-B H12	
3242-C H12	
3242-D H12	
3243-A A12	
3243-B A12	
3243-C A12	
3243-D A12	
3245 H10	
3246 H10	
3247-A C4	
3247-B C4	
3247-C H6	
3247-D H5	
3248-A H5	
3248-B I5	
3248-C I5	
3248-D I5	
3249 H10	
3255 D4	
3260 F12	
3261 F13	
3271-A C12	
3271-B C12	
3271-C C12	
3271-D C12	
3273-A C12	
3273-B D12	
3273-C D12	
3273-D D12	
3274 A6	
3276 H8	
3280 H9	
3281 H7	
3286 B4	
3287 H7	
3288 F3	
3289 E3	
3290 E3	
3291 E3	
3295 D3	
3297 C3	
3299 C3	
3702 C13	
3703 C13	
3749 A6	
3807 B12	
3887 A12	
5201 A8	
5202 A9	
5203 H3	
7207 H3	
7215-A D2	
7270 A4	
F302 A8	
F303 A8	
F304 A6	
F307 H6	
F314 A12	
F318 B12	
F322 B4	

CDR MAIN BOARD - CIRCUIT DIAGRAM 8 : TEST & CONNECTOR PART

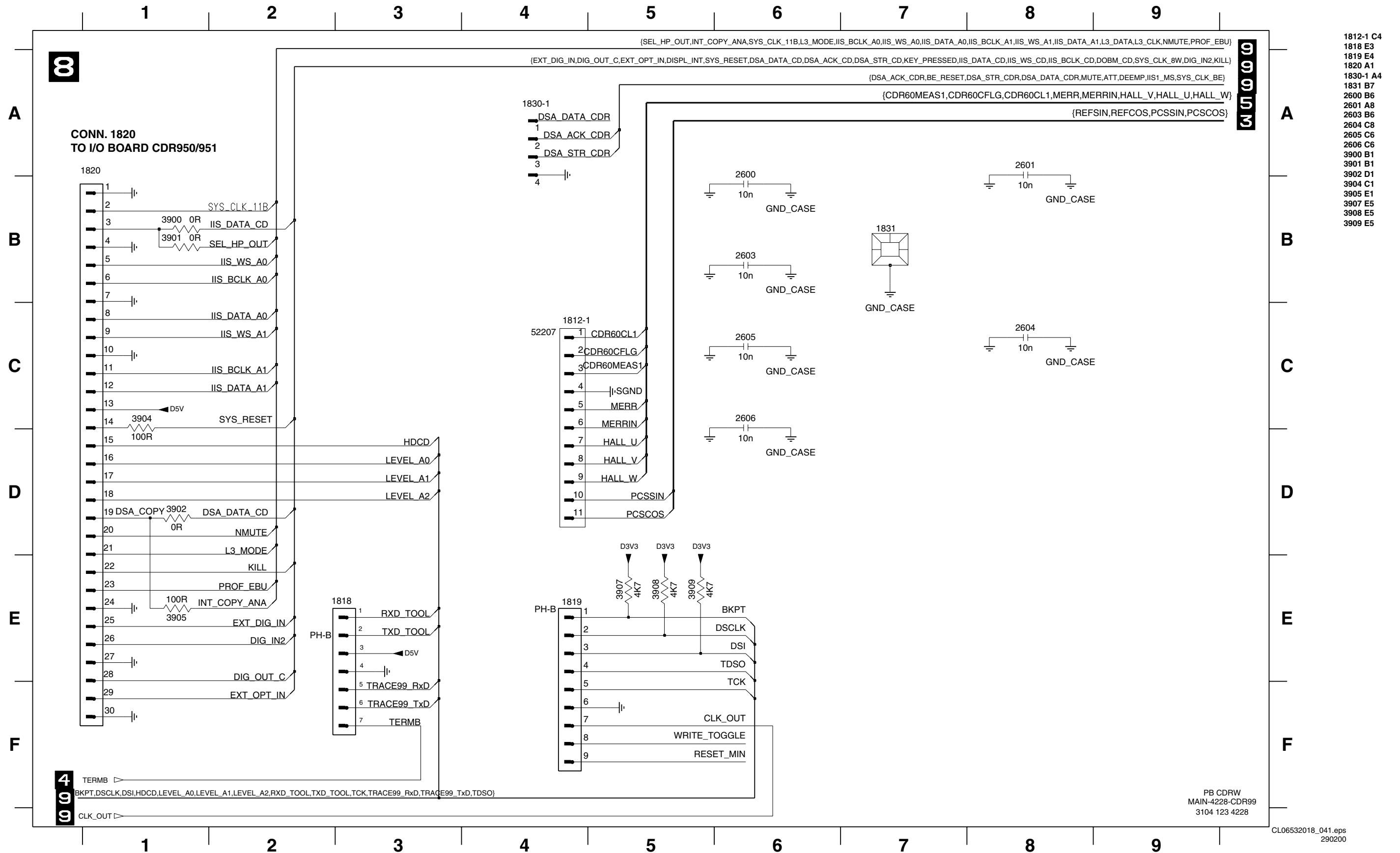

- 1812-1 C4
- 1818 E3
- 1819 E4
- 1820 A1
- 1830-1 A4
- 1831 B7
- 2600 B6
- 2601 A8
- 2603 B6
- 2604 C8
- 2605 C6
- 2606 C6
- 3900 B1
- 3901 B1
- 3902 D1
- 3904 C1
- 3905 E1
- 3907 E5
- 3908 E5
- 3909 E5

PB CDRW
MAIN-4228-CDR99
3104 123 4228

CDR MAIN BOARD - CIRCUIT DIAGRAM 10 : DASP FLASH & DRAM TESTPOINTS

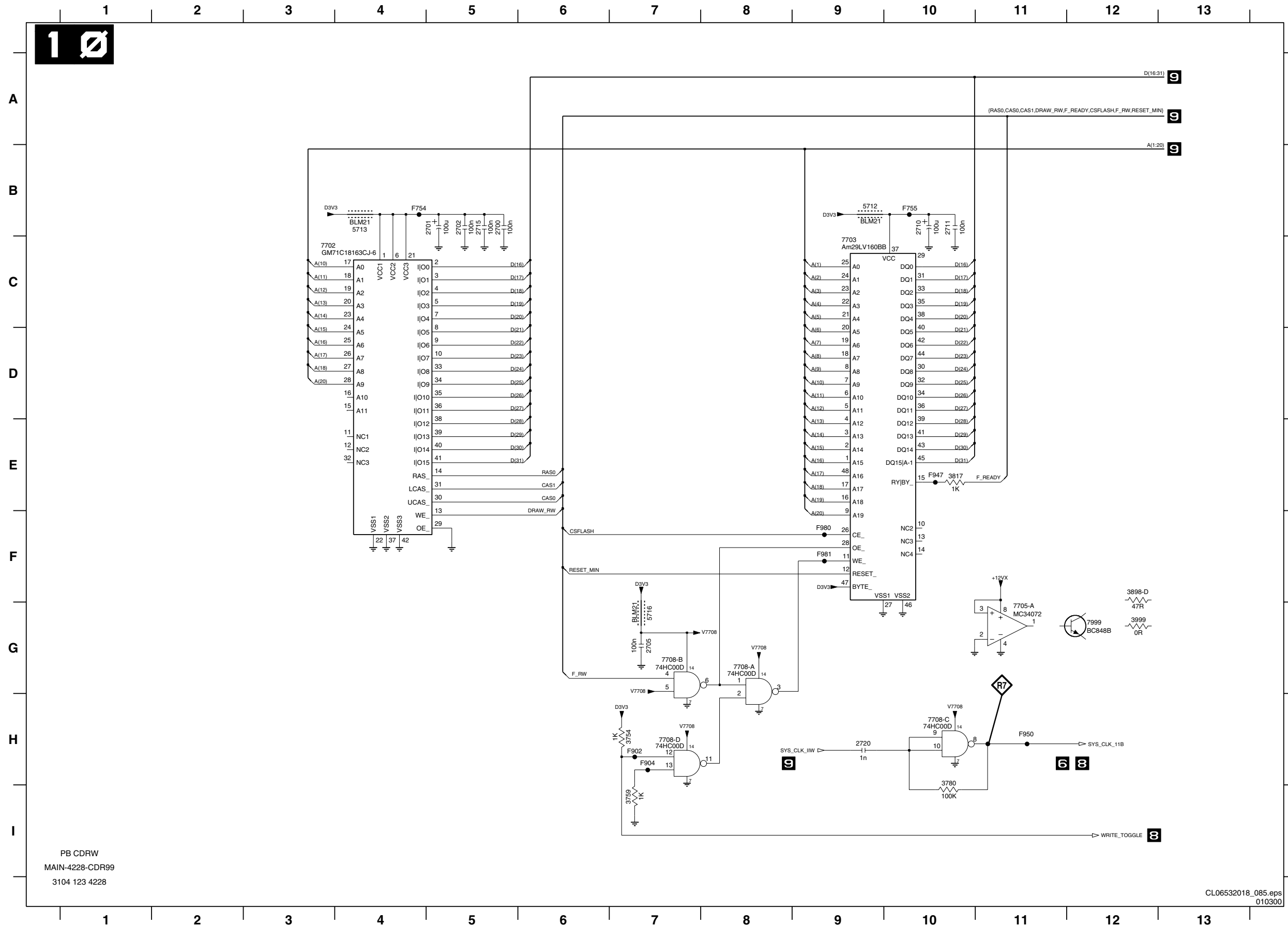

- 2700 B5
- 2701 B5
- 2702 B5
- 2705 G7
- 2710 B10
- 2711 B10
- 2715 B5
- 2720 H9
- 3754 H7
- 3759 I7
- 3780 I10
- 3817 E10
- 3898-D F12
- 3999 G12
- 5712 B9
- 5713 B4
- 5716 G7
- 7702 C3
- 7703 C9
- 7705-A G11
- 7708-A G8
- 7708-B G7
- 7708-C H10
- 7708-D H7
- 7999 G12
- F754 B4
- F755 B10
- F902 H7
- F904 H7
- F947 E10
- F950 H11
- F980 F9
- F981 F9

PB CDRW
MAIN-4228-CDR99
3104 123 4228

CDR MAIN BOARD - TOP VIEW

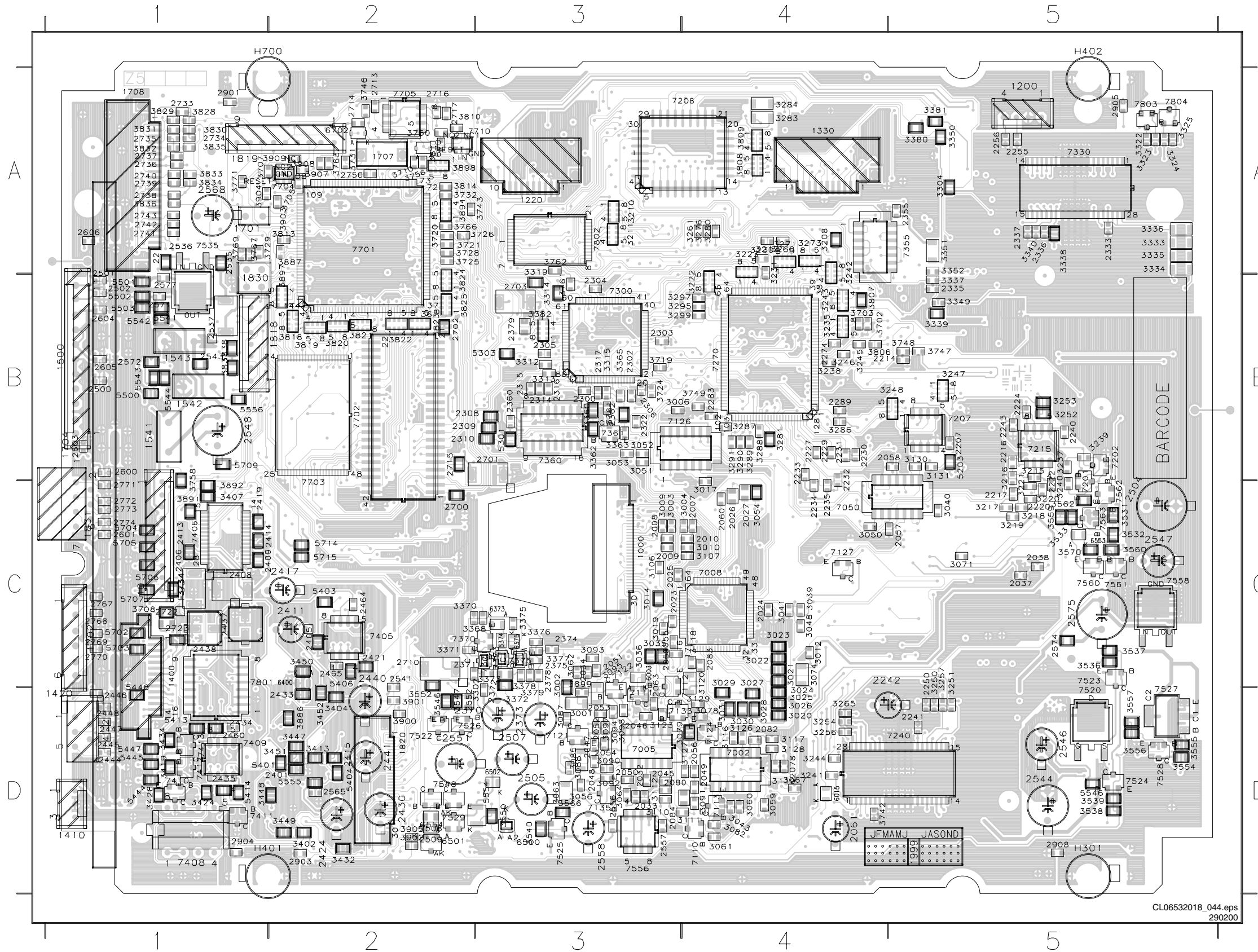

CL06532018_044.eps
290200

1000	1001	1002	1003	1004	1005	1006	1007	1008	1009	1010	1011	1012	1013	1014	1015	1016	1017	1018	1019	1020	1021	1022	1023	1024	1025	1026	1027	1028	1029	1030	1031	1032	1033	1034	1035	1036	1037	1038	1039	1040	1041	1042	1043	1044	1045	1046	1047	1048	1049	1050	1051	1052	1053	1054	1055	1056	1057	1058	1059	1060	1061	1062	1063	1064	1065	1066	1067	1068	1069	1070	1071	1072	1073	1074	1075	1076	1077	1078	1079	1080	1081	1082	1083	1084	1085	1086	1087	1088	1089	1090	1091	1092	1093	1094	1095	1096	1097	1098	1099	1100	1101	1102	1103	1104	1105	1106	1107	1108	1109	1110	1111	1112	1113	1114	1115	1116	1117	1118	1119	1120	1121	1122	1123	1124	1125	1126	1127	1128	1129	1130	1131	1132	1133	1134	1135	1136	1137	1138	1139	1140	1141	1142	1143	1144	1145	1146	1147	1148	1149	1150	1151	1152	1153	1154	1155	1156	1157	1158	1159	1160	1161	1162	1163	1164	1165	1166	1167	1168	1169	1170	1171	1172	1173	1174	1175	1176	1177	1178	1179	1180	1181	1182	1183	1184	1185	1186	1187	1188	1189	1190	1191	1192	1193	1194	1195	1196	1197	1198	1199	1200
------	------	------	------	------	------	------	------	------	------	------	------	------	------	------	------	------	------	------	------	------	------	------	------	------	------	------	------	------	------	------	------	------	------	------	------	------	------	------	------	------	------	------	------	------	------	------	------	------	------	------	------	------	------	------	------	------	------	------	------	------	------	------	------	------	------	------	------	------	------	------	------	------	------	------	------	------	------	------	------	------	------	------	------	------	------	------	------	------	------	------	------	------	------	------	------	------	------	------	------	------	------	------	------	------	------	------	------	------	------	------	------	------	------	------	------	------	------	------	------	------	------	------	------	------	------	------	------	------	------	------	------	------	------	------	------	------	------	------	------	------	------	------	------	------	------	------	------	------	------	------	------	------	------	------	------	------	------	------	------	------	------	------	------	------	------	------	------	------	------	------	------	------	------	------	------	------	------	------	------	------	------	------	------	------	------	------	------	------	------	------	------	------	------	------	------	------	------	------	------	------

CDR-Mainboard Version 4228.7

CDR MAIN BOARD - CIRCUIT DIAGRAM 1 : AEGER, EFMTIM, FORWARD SENSE CIRCUIT TESTPOINTS

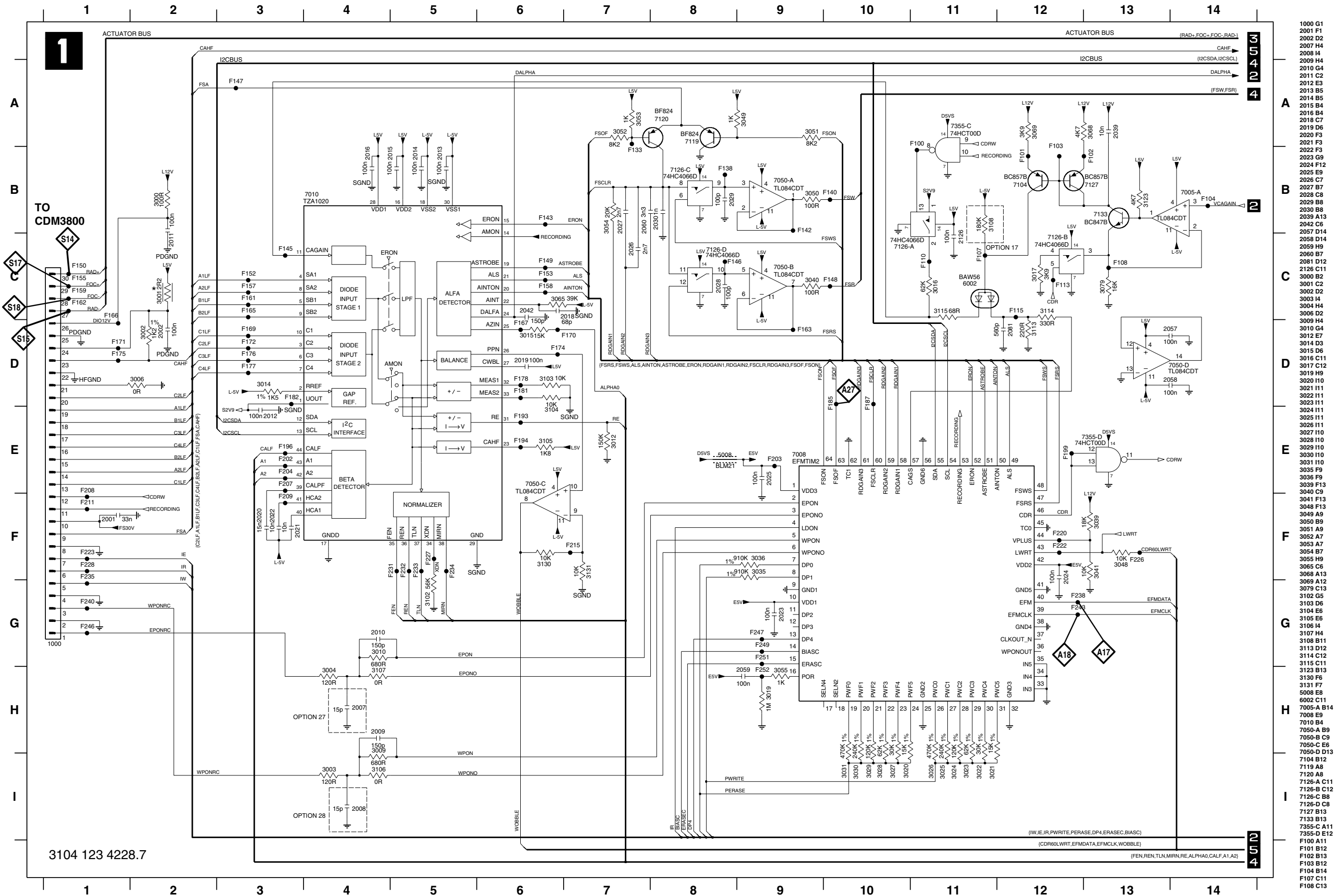

- 1000 G1
- 2001 F1
- 2002 D2
- 2007 H4
- 2008 I4
- 2009 H4
- 2010 G4
- 2011 C2
- 2012 E3
- 2013 B5
- 2014 B5
- 2015 B4
- 2016 B4
- 2018 C7
- 2019 D6
- 2020 F3
- 2021 F3
- 2022 F3
- 2023 G9
- 2024 F12
- 2025 E9
- 2026 C7
- 2027 B7
- 2028 C8
- 2029 B8
- 2030 B8
- 2030 A13
- 2039 A8
- 2042 C6
- 2057 D14
- 2058 D14
- 2059 H9
- 2060 B7
- 2081 D12
- 2126 C11
- 3000 B2
- 3001 C2
- 3002 D2
- 3003 I4
- 3004 H4
- 3006 D2
- 3009 H4
- 3010 G4
- 3012 E7
- 3014 D3
- 3015 D6
- 3016 C11
- 3017 C12
- 3019 H9
- 3020 I10
- 3021 I11
- 3022 I11
- 3022 I11
- 3023 I11
- 3024 I11
- 3025 I11
- 3026 I11
- 3027 I10
- 3028 I10
- 3029 I10
- 3030 I10
- 3031 I10
- 3035 F9
- 3036 F9
- 3039 F13
- 3040 C9
- 3041 F13
- 3048 F13
- 3049 A9
- 3050 B9
- 3051 A9
- 3052 A7
- 3053 A7
- 3054 B7
- 3055 H9
- 3056 C6
- 3068 A13
- 3069 A13
- 3079 C13
- 3102 G5
- 3103 D6
- 3104 E6
- 3105 E6
- 3106 H4
- 3107 H4
- 3108 B11
- 3113 D12
- 3114 C12
- 3115 C11
- 3123 B13
- 3130 F8
- 3131 F7
- 5008 E8
- 6002 C11
- 7005-A B14
- 7008 E9
- 7010 B4
- 7050-A B9
- 7050-B C9
- 7050-C E6
- 7050-D D13
- 7104 B12
- 7119 A8
- 7120 A8
- 7126-A C11
- 7126-B C12
- 7126-C B8
- 7126-D C8
- 7127 B13
- 7133 B13
- 7355-C A11
- 7355-D E12
- F100 A11
- F101 B12
- F102 B13
- F103 B12
- F104 B14
- F107 C11
- F108 C13
- F110 C11
- F113 C12
- F115 C12
- F133 B7
- F138 B8
- F140 B10
- F142 B9
- F143 B6
- F145 C2
- F146 C8
- F147 A3
- F148 C10
- F149 C6
- F150 C1
- F152 C3
- F153 C5
- F155 C1
- F157 C3
- F158 C3
- F159 C1
- F162 C1
- F163 D9
- F165 C3
- F166 C1
- F167 D6
- F169 D3
- F170 D7
- F171 D1
- F172 D3
- F174 D6
- F175 D1
- F176 D3
- F177 D3
- F178 D6
- F181 D6
- F182 D3
- F185 D10
- F187 D10
- F193 E6
- F194 E6
- F196 E3
- F199 E12
- F202 E3
- F203 E9
- F204 E3
- F207 E3
- F208 E1
- F209 F3
- F211 F1
- F215 F7
- F220 F12
- F221 F12
- F222 F12
- F223 F1
- F226 F13
- F227 F5
- F228 F10
- F231 F4
- F232 F5
- F233 F5
- F234 F5
- F235 F1
- F238 G12
- F240 G1
- F243 G12
- F246 G1
- F247 G9
- F249 G9
- F251 G9
- F252 H9

3104 123 4228.7

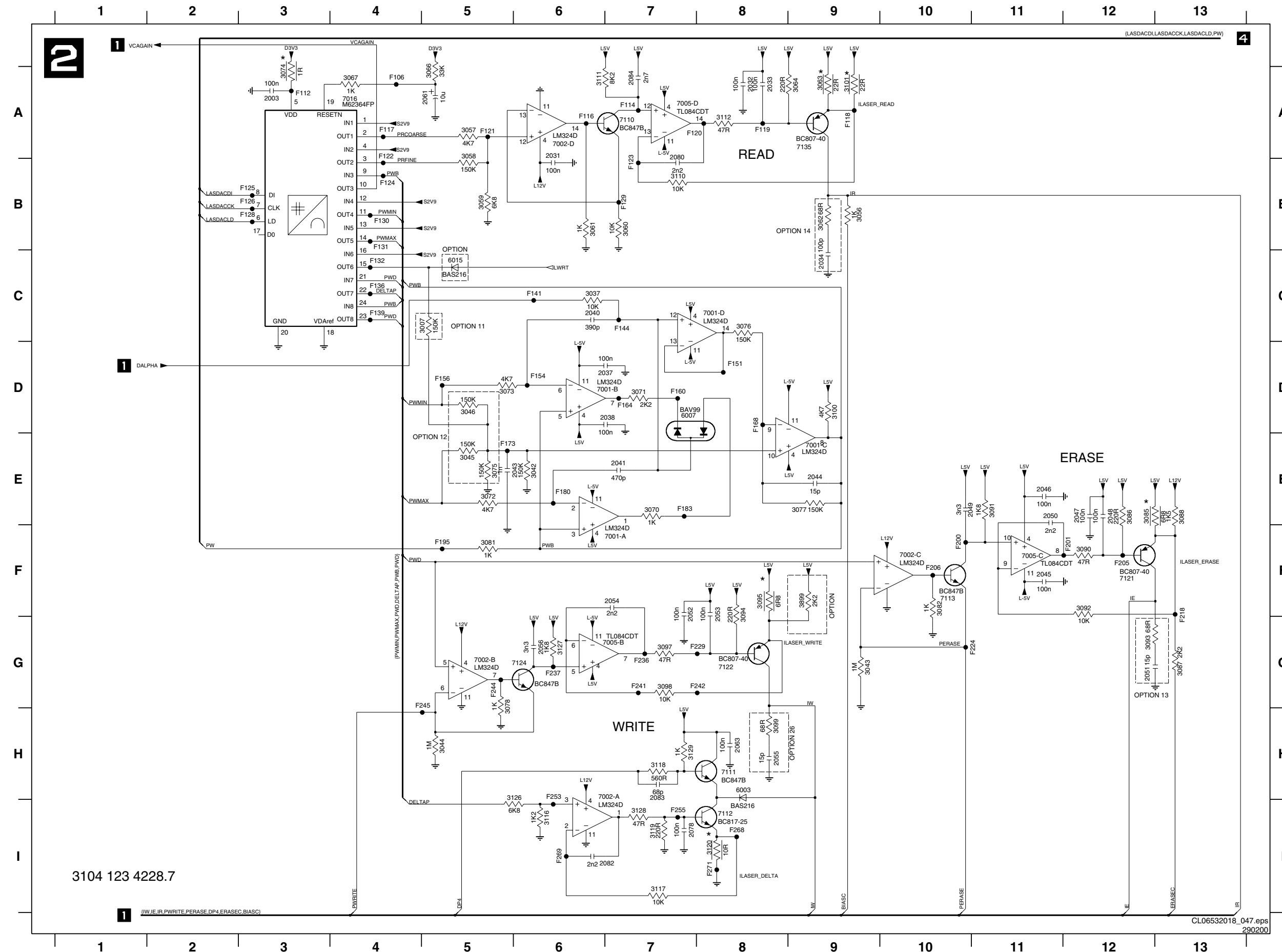

3104 123 4228.7

(/I/IE/IR/PWRITE/PERASE/DP4/ERASEC/BIASC)

CL06532018_047.eps
290200

- 2003 A3
- 2031 A6
- 2032 A8
- 2033 A8
- 2034 C9
- 2037 D7
- 2038 D7
- 2040 C6
- 2041 E7
- 2043 E5
- 2044 E9
- 2045 F11
- 2046 E11
- 2047 E12
- 2048 E12
- 2049 E10
- 2050 E11
- 2051 G12
- 2052 F7
- 2053 F8
- 2054 F7
- 2055 H8
- 2056 G6
- 2061 A5
- 2063 H8
- 2078 I7
- 2080 B7
- 2082 I7
- 2083 I7
- 2084 A7
- 3007 C5
- 3037 C6
- 3042 E6
- 3043 G9
- 3044 H5
- 3045 E5
- 3046 D5
- 3056 B9
- 3057 A5
- 3058 B5
- 3059 B5
- 3060 B7
- 3061 B6
- 3062 B9
- 3063 A9
- 3064 A9
- 3066 A5
- 3067 A4
- 3070 E7
- 3071 D7
- 3072 E5
- 3073 D5
- 3074 A3
- 3075 E5
- 3076 C8
- 3077 E9
- 3078 G5
- 3081 F5
- 3082 F10
- 3085 E12
- 3086 E12
- 3087 G13
- 3088 E13
- 3090 F12
- 3091 E11
- 3092 F12
- 3093 G12
- 3094 F8
- 3095 F8
- 3097 G7
- 3098 G7
- 3099 H8
- 3100 D9
- 3101 A9
- 3110 B7
- 3111 A6
- 3112 A8
- 3116 I6
- 3117 I7
- 3118 H7
- 3119 I7
- 3120 I8
- 3126 I6
- 3127 G6
- 3128 I7
- 3129 H7
- 3899 F9
- 6003 H8
- 6007 D7
- 6015 C5
- 7001-A F7
- 7001-B D6
- 7001-C E9
- 7001-D C8
- 7002-A H6
- 7002-B G5
- 7002-C F10
- 7002-D A6
- 7005-B G6
- 7005-C F11
- 7005-D A7
- 7016 A4
- 7110 A7
- 7111 H8
- 7112 I8
- 7113 F10
- 7121 F12
- 7122 G8
- 7124 G5
- 7135 A9
- F106 A4
- F112 A3
- F114 A7
- F116 A6
- F117 A4
- F118 A9
- F119 A8
- F120 A7
- F121 A5
- F122 A4
- F123 B7
- F124 B4
- F125 B3
- F126 B3
- F128 B3
- F129 B7
- F130 B4
- F131 B4
- F132 C4
- F135 C4
- F139 C4
- F141 C6
- F144 C7
- F151 D8
- F154 D6
- F156 D5
- F160 D7
- F164 D7
- F168 D8
- F173 E5
- F180 E6
- F183 E7
- F195 F5
- F200 F10
- F201 F12
- F205 F12
- F206 F10
- F218 F13
- F224 G10
- F229 G6
- F236 G7
- F237 G6
- F241 G7
- F242 G8
- F244 G5
- F245 G5
- F253 H6
- F255 I7
- F268 I8
- F269 I6
- F271 I8

CDR MAIN BOARD - CIRCUIT DIAGRAM 4 : MACE BE-PROCESSOR TESTPOINTS

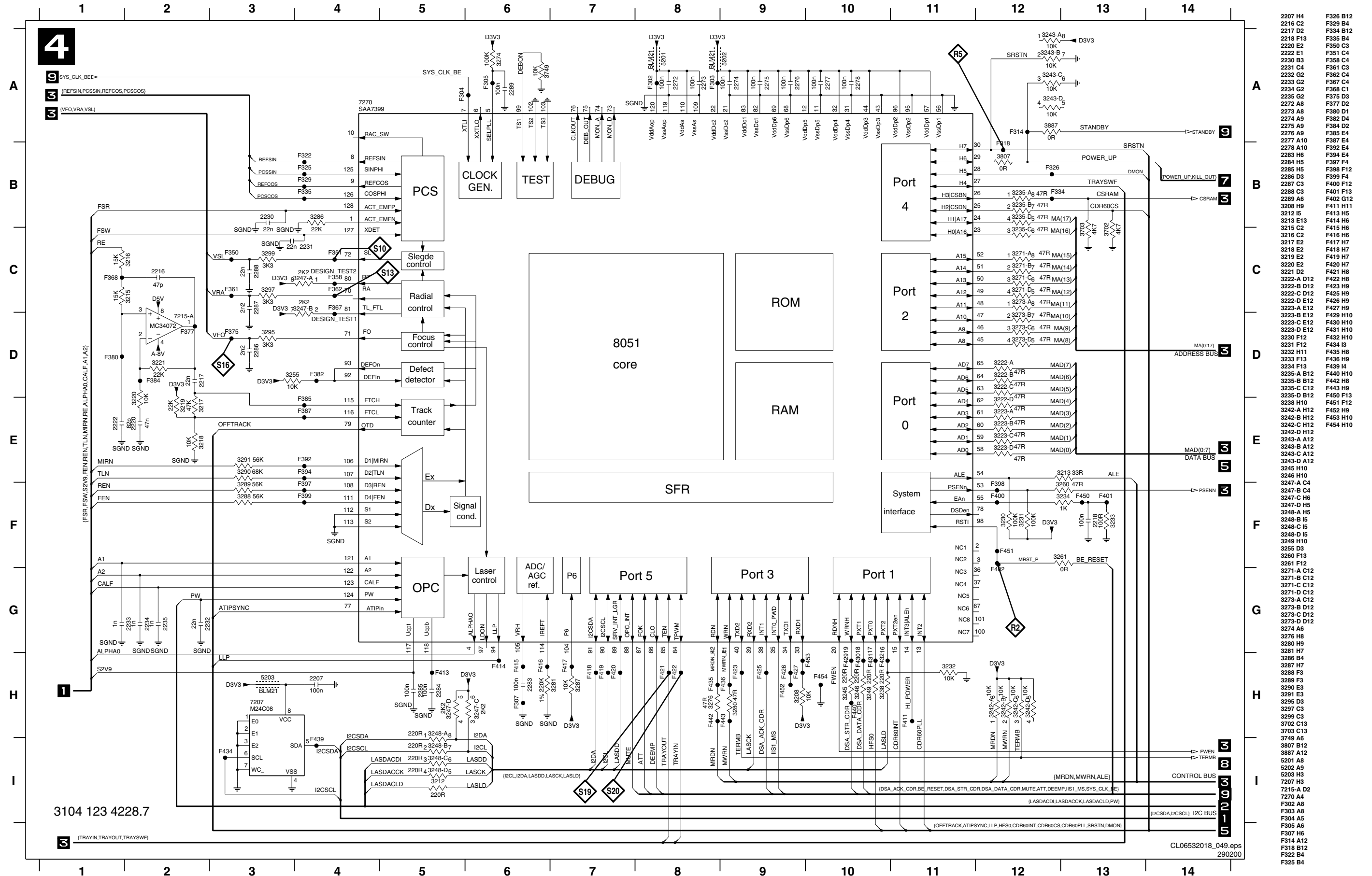

- 2207 H4
- 2216 C2
- 2217 D2
- 2218 F13
- 2220 E2
- 2222 E1
- 2230 B3
- 2231 C4
- 2232 G2
- 2233 G2
- 2234 G2
- 2235 G2
- 2272 A8
- 2273 A8
- 2274 A9
- 2275 A9
- 2276 A9
- 2277 A10
- 2278 A10
- 2283 H6
- 2284 H5
- 2285 H5
- 2286 D3
- 2287 C3
- 2288 C3
- 2289 A5
- 3208 H9
- 3212 I5
- 3213 E13
- 3215 C2
- 3216 H6
- 3217 E2
- 3218 E2
- 3219 H7
- 3220 E2
- 3221 D2
- 3222-A D12
- 3222-B D12
- 3222-C D12
- 3222-D E12
- 3223-A E12
- 3223-B E12
- 3223-C E12
- 3223-D E12
- 3230 F12
- 3231 F12
- 3232 H11
- 3233 F13
- 3234 F13
- 3235-A B12
- 3235-B B12
- 3235-C C12
- 3235-D B12
- 3238 H10
- 3242-A H12
- 3242-B H12
- 3242-C H12
- 3242-D H12
- 3243-A A12
- 3243-B A12
- 3243-C A12
- 3243-D A12
- 3245 H10
- 3246 H10
- 3247-A C4
- 3247-B C4
- 3247-C H6
- 3247-D H5
- 3248-A H5
- 3248-B I5
- 3248-C I5
- 3248-D I5
- 3249 H10
- 3255 D3
- 3260 F13
- 3261 F12
- 3271-A C12
- 3271-B C12
- 3271-C C12
- 3271-D C12
- 3273-A C12
- 3273-B D12
- 3273-C D12
- 3273-D D12
- 3274 A6
- 3276 H8
- 3280 H9
- 3281 H7
- 3286 B4
- 3287 H7
- 3288 F3
- 3289 F3
- 3290 E3
- 3291 E3
- 3293 D3
- 3297 C3
- 3299 C3
- 3702 C13
- 3703 C13
- 3749 A6
- 3807 B12
- 3887 A12
- 5201 A8
- 5202 A9
- 5203 H3
- 7207 H3
- 7215-A D2
- 7270 A4
- F302 A8
- F303 A8
- F304 A5
- F305 A6
- F307 H6
- F314 A12
- F318 B12
- F322 B4
- F325 B4
- F350 C3
- F351 C4
- F358 C4
- F361 C3
- F362 C4
- F367 C4
- F368 C1
- F375 D3
- F377 D2
- F380 D1
- F382 D4
- F384 D2
- F385 E4
- F387 E4
- F392 E4
- F394 E4
- F397 F4
- F398 F12
- F399 F4
- F400 F12
- F401 F13
- F402 G12
- F411 H11
- F413 H5
- F414 H6
- F415 H6
- F416 H6
- F417 H7
- F420 H7
- F421 H8
- F422 H8
- F423 H9
- F425 H9
- F426 H9
- F427 H9
- F429 H10
- F430 H10
- F431 H10
- F432 H10
- F434 I3
- F435 H8
- F436 H9
- F439 I4
- F440 H10
- F442 H8
- F443 H9
- F450 F13
- F451 F12
- F452 H9
- F453 H10
- F454 H10

CDR MAIN BOARD - CIRCUIT DIAGRAM 5 : CD ENCODING-DECODING PART

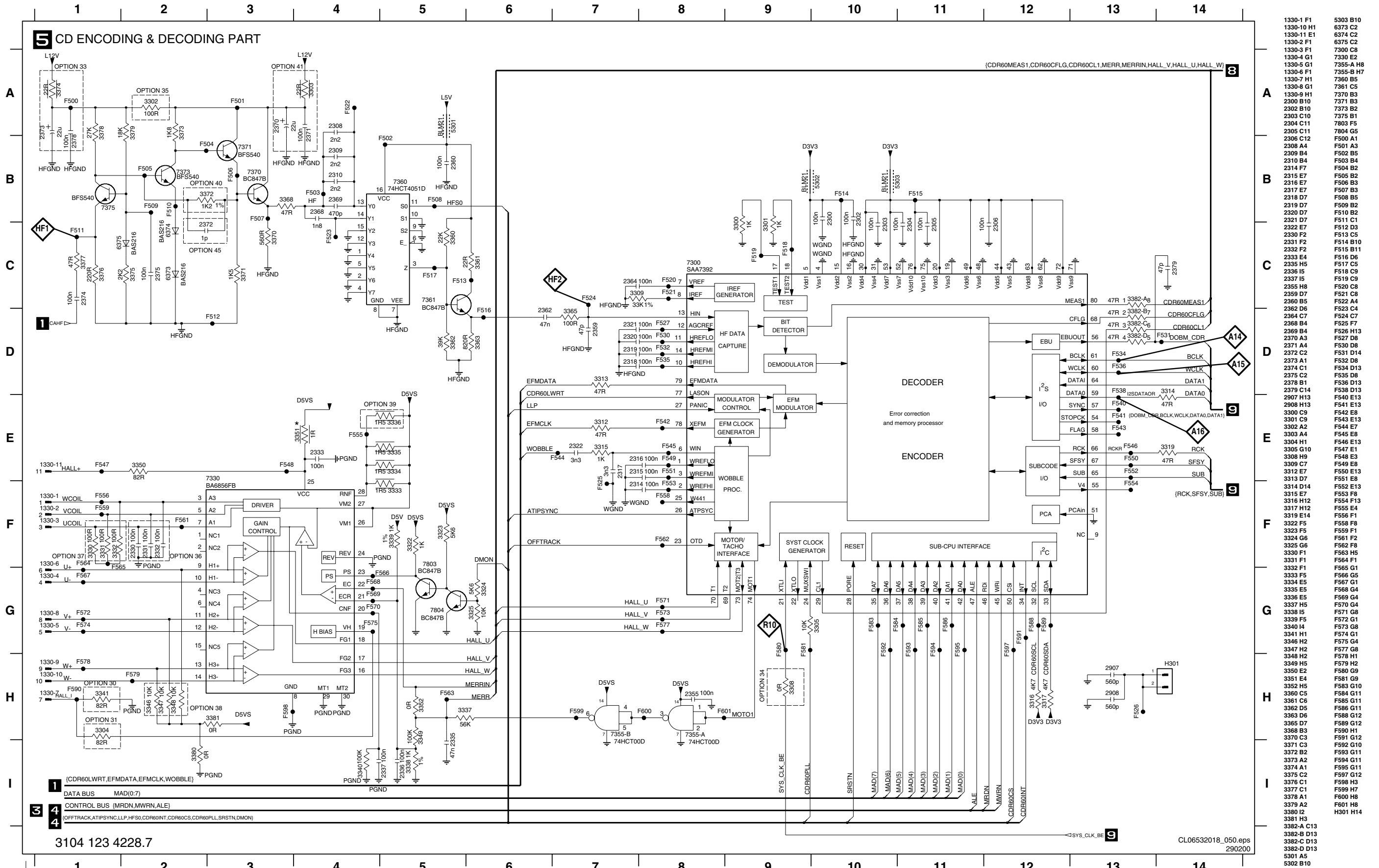

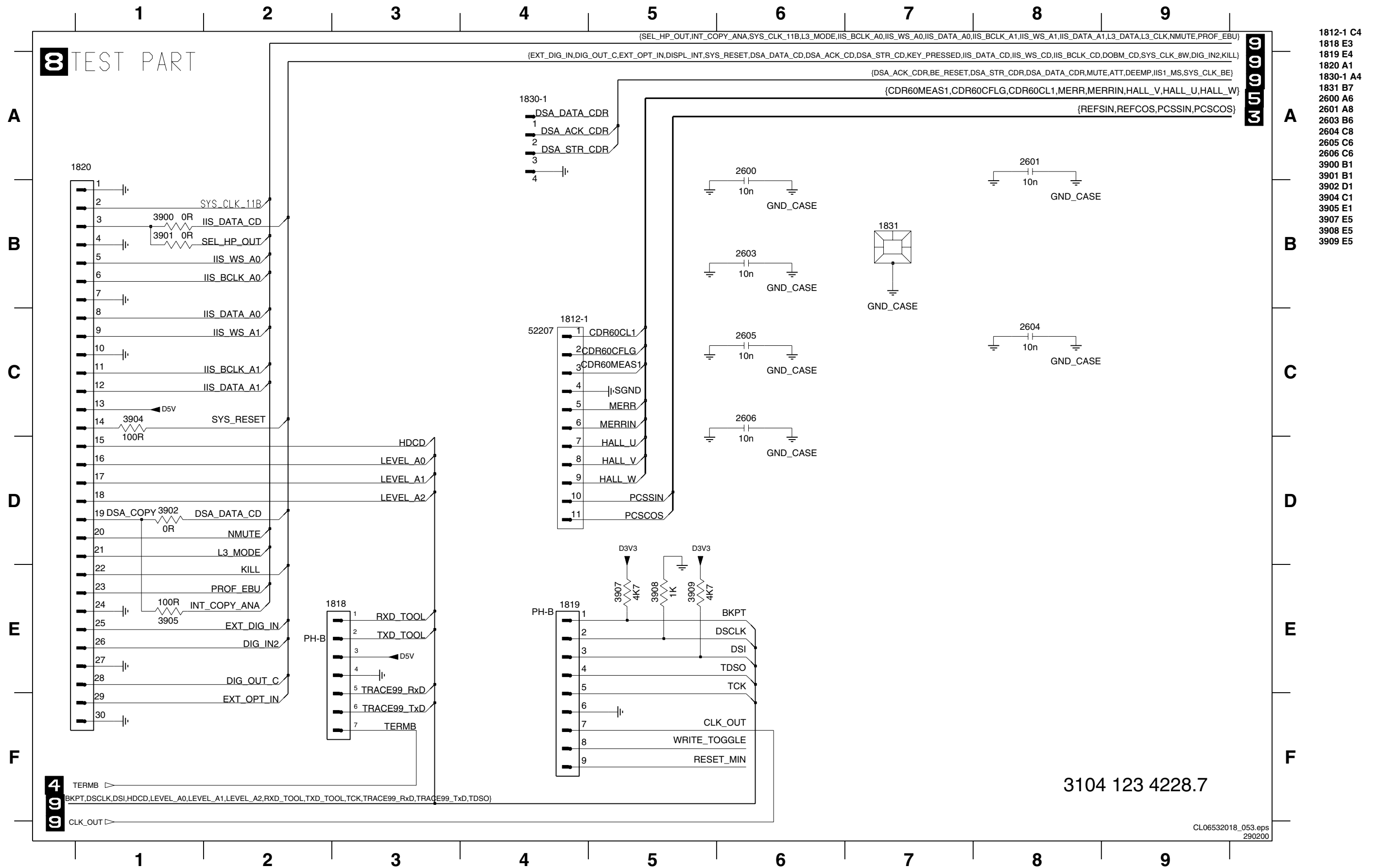

- 1812-1 C4
- 1818 E3
- 1819 E4
- 1820 A1
- 1830-1 A4
- 1831 B7
- 2600 A6
- 2601 A8
- 2603 B6
- 2604 C8
- 2605 C6
- 2606 C6
- 3900 B1
- 3901 B1
- 3902 D1
- 3904 C1
- 3905 E1
- 3907 E5
- 3908 E5
- 3909 E5

CDR MAIN BOARD - CIRCUIT DIAGRAM 9 : DASP MASTER PROCESSOR TESTPOINTS

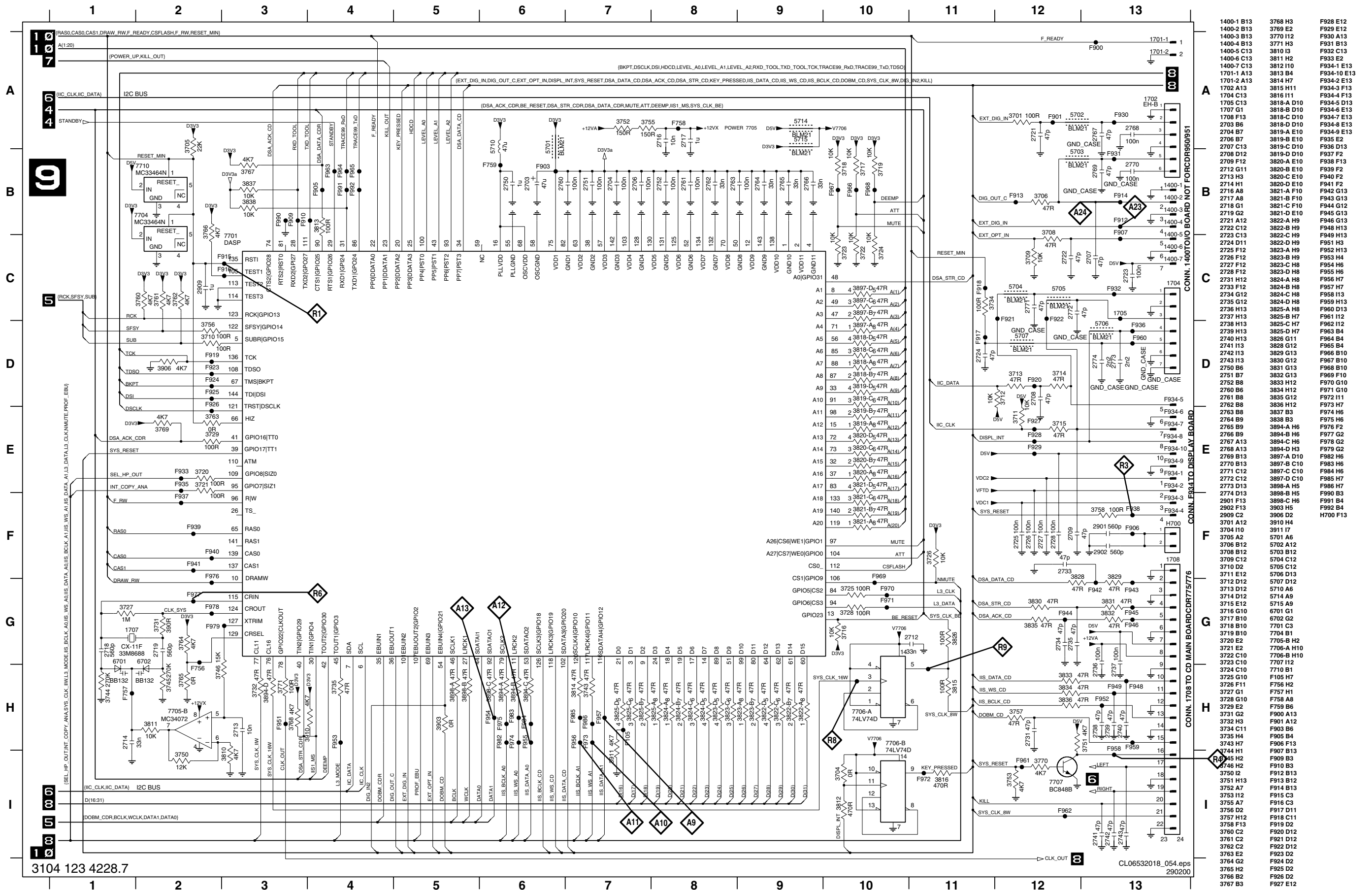

3104 123 4228.7

CL06532018_054.eps
290200

CDR MAIN BOARD - CIRCUIT DIAGRAM 10 : DASP FLASH & DRAM TESTPOINTS

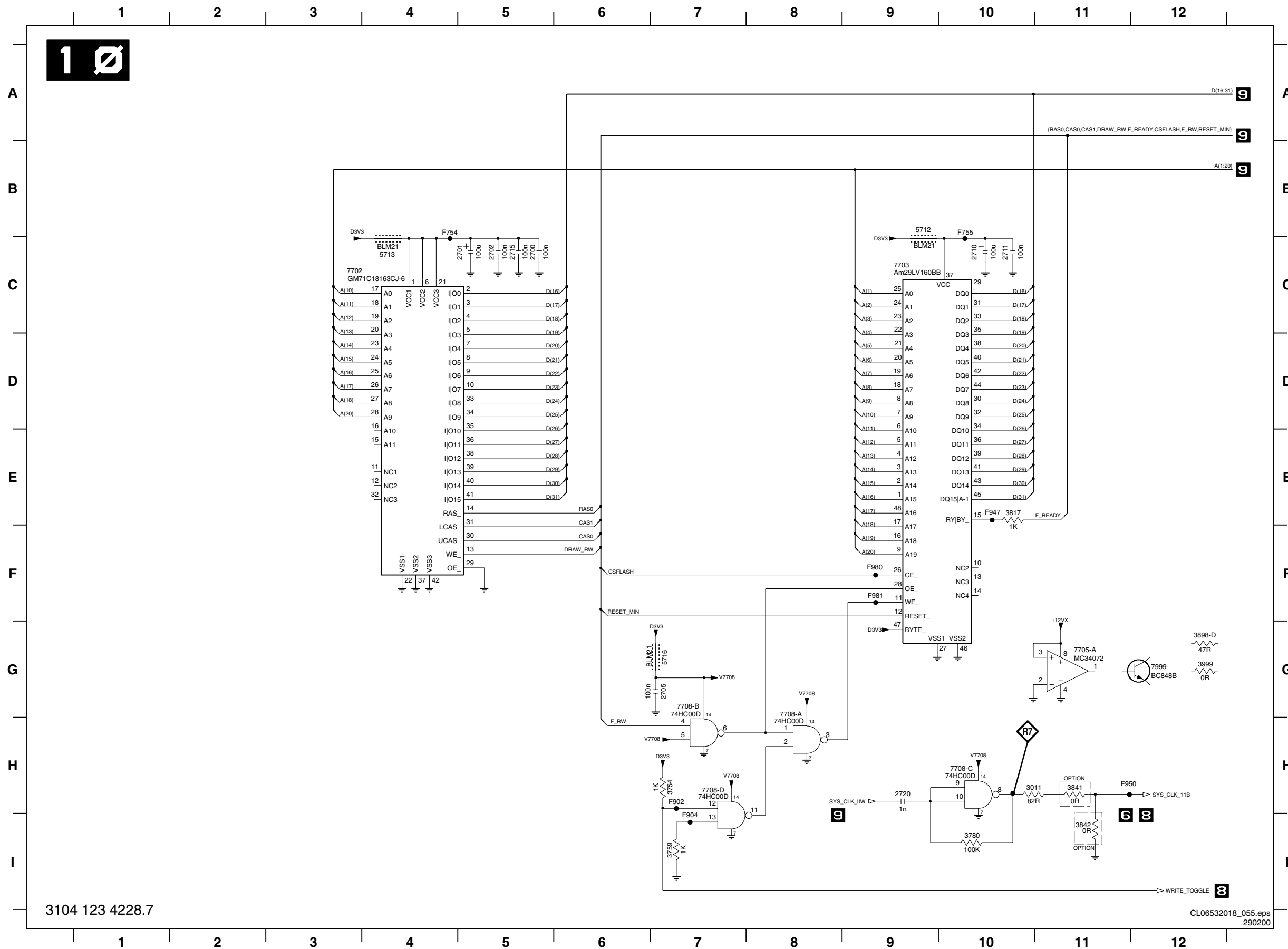

- 2700 C5
- 2701 C5
- 2702 C5
- 2705 G7
- 2710 C10
- 2711 C10
- 2715 C5
- 2720 H9
- 3011 H10
- 3754 H7
- 3759 I7
- 3780 I10
- 3817 E10
- 3841 H11
- 3842 I11
- 3898-D G12
- 3999 G12
- 5712 B9
- 5713 C4
- 5716 G7
- 7702 C3
- 7703 C9
- 7705-A G11
- 7708-A G8
- 7708-B G7
- 7708-C H10
- 7708-D H7
- 7999 G12
- F754 B4
- F755 B10
- F902 H7
- F904 I7
- F947 E10
- F950 H11
- F980 F9
- F981 F9

3104 123 4228.7

CL06532018_055.eps
290200

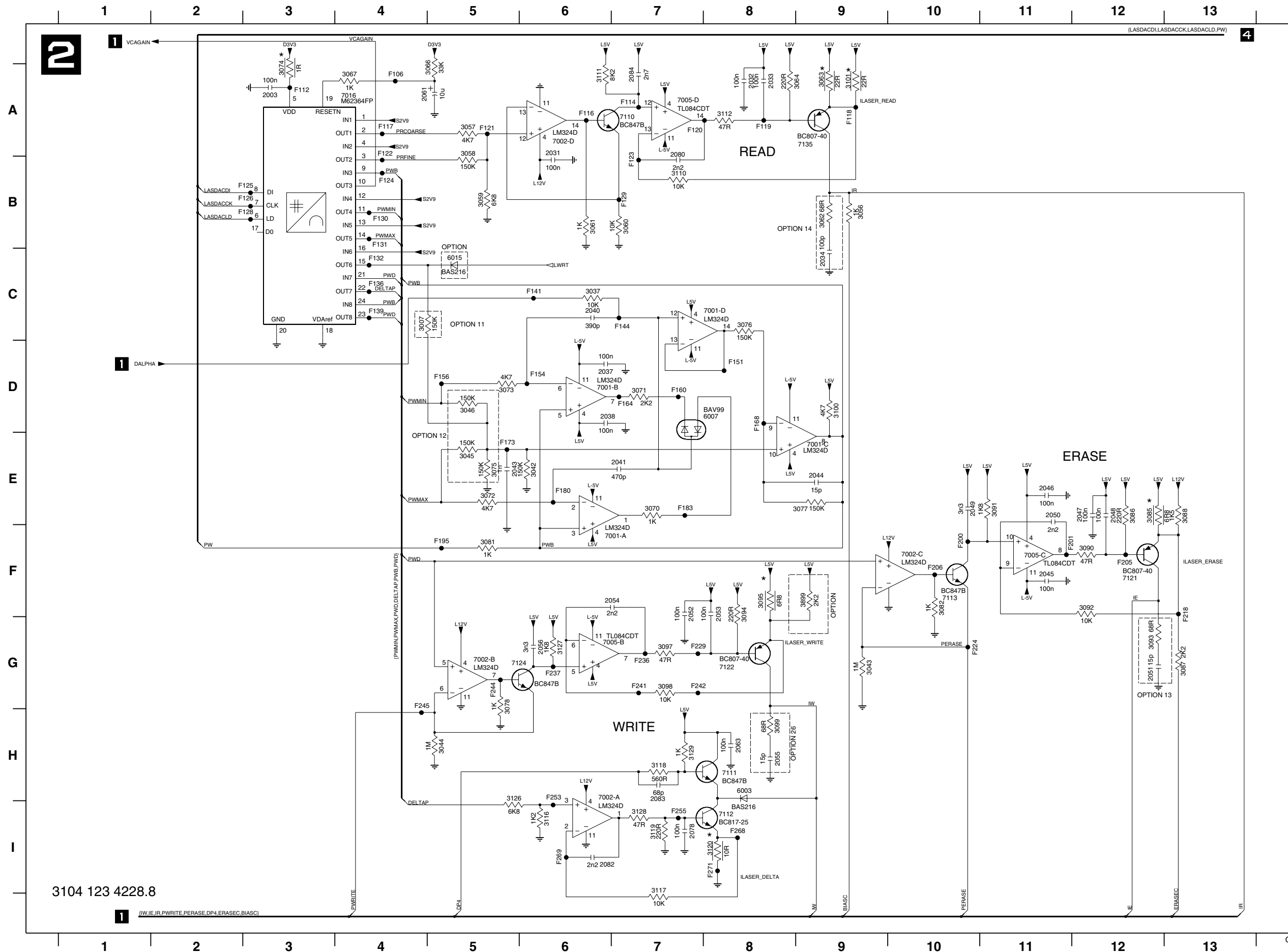

2003 A3	F120 A7
2031 A6	F121 A5
2032 A8	F122 A4
2033 A8	F123 B7
2034 C9	F124 B4
2037 D6	F125 B3
2038 D6	F126 B3
2040 C6	F128 B3
2041 E7	F129 B7
2043 E5	F130 B4
2044 E9	F131 B4
2045 F11	F132 C4
2046 E11	F136 C4
2047 E12	F139 C4
2048 E12	F141 C6
2049 E10	F144 C7
2050 E11	F151 D8
2051 G12	F154 D6
2052 F7	F156 D5
2053 F8	F160 D7
2054 F7	F164 D7
2055 H8	F168 D8
2056 G6	F173 E5
2061 A4	F180 E6
2063 H8	F183 E7
2078 I7	F195 F5
2080 B7	F200 F10
2082 I6	F201 F11
2083 H7	F205 F12
2084 A7	F206 F10
3007 C4	F218 F13
3037 C6	F224 G10
3042 E6	F229 G7
3043 G9	F236 G7
3044 H5	F237 G6
3045 E5	F241 G7
3046 D5	F242 G7
3056 B9	F244 G5
3057 A5	F245 G4
3058 A5	F253 H6
3059 B5	F255 I7
3060 B7	F268 I8
3061 B6	F269 I6
3062 B9	F271 I8
3063 A9	
3064 A8	
3066 A5	
3067 A4	
3070 E7	
3071 D7	
3072 E5	
3073 D5	
3074 A3	
3075 E5	
3076 C8	
3077 E9	
3078 G5	
3081 F5	
3082 F10	
3085 E12	
3086 E12	
3087 G13	
3088 E13	
3090 F12	
3091 E11	
3092 F12	
3093 G12	
3094 F8	
3095 F8	
3097 G7	
3098 G7	
3099 H8	
3100 D9	
3101 A9	
3110 B7	
3111 A6	
3112 A8	
3116 I6	
3117 I7	
3118 H7	
3119 I7	
3120 I6	
3126 H5	
3127 G6	
3128 I7	
3129 H7	
3899 F9	
6003 H8	
6007 D8	
6015 C5	
7001-A F6	
7001-B D6	
7001-C E9	
7001-D C8	
7002-A H6	
7002-B G5	
7002-C F10	
7002-D A6	
7005-B G6	
7005-C F11	
7005-D A7	
7016 A4	
7110 A7	
7111 H8	
7112 I8	
7113 F10	
7121 F12	
7122 G8	
7124 G5	
7135 A9	
F106 A4	
F112 A3	
F114 A7	
F116 A6	
F117 A4	
F118 A9	
F119 A8	

3104 123 4228.8

CDR MAIN BOARD - CIRCUIT DIAGRAM 3 : SERVO DRIVERS, MACE-RAM, -FLASH, -DEMUX TEST POINTS

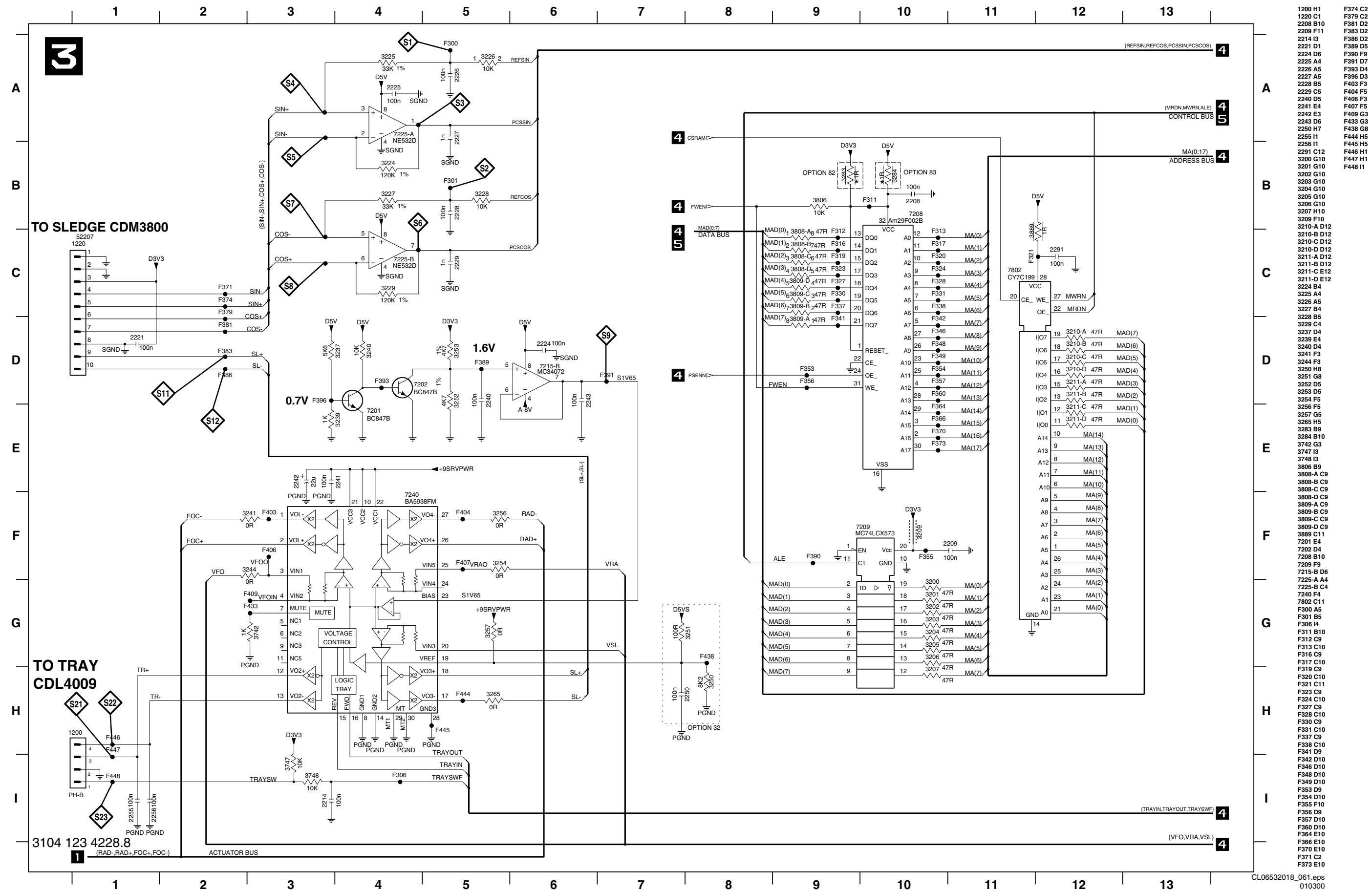

- 1200 H1
- 1220 C1
- 2208 B10
- 2209 F11
- 2214 I3
- 2221 D1
- 2224 D6
- 2225 A4
- 2226 A5
- 2227 A5
- 2228 B5
- 2229 C5
- 2240 D5
- 2241 E4
- 2242 E3
- 2243 D6
- 2250 H7
- 2255 I1
- 2256 I1
- 2291 C12
- 3200 G10
- 3201 G10
- 3202 G10
- 3203 C10
- 3204 G10
- 3205 G10
- 3206 G10
- 3207 H10
- 3209 F10
- 3210-A D12
- 3210-B D12
- 3210-C D12
- 3210-D D12
- 3211-A D12
- 3211-B D12
- 3211-C E12
- 3211-D E12
- 3224 B4
- 3225 A4
- 3226 A5
- 3227 B4
- 3228 B5
- 3229 C4
- 3237 D4
- 3239 E4
- 3240 D4
- 3241 F3
- 3244 F3
- 3250 H8
- 3251 G8
- 3252 D5
- 3253 D5
- 3254 F5
- 3256 F5
- 3257 G5
- 3265 H5
- 3283 B9
- 3284 B10
- 3285 H5
- 3288 B9
- 3289 B9
- 3290 B9
- 3291 B9
- 3292 B9
- 3293 B9
- 3294 B9
- 3295 B9
- 3296 B9
- 3297 B9
- 3298 B9
- 3299 B9
- 3300 B9
- 3301 B9
- 3302 B9
- 3303 B9
- 3304 B9
- 3305 B9
- 3306 B9
- 3307 B9
- 3308 B9
- 3309 B9
- 3310 B9
- 3311 B9
- 3312 B9
- 3313 B9
- 3314 B9
- 3315 B9
- 3316 B9
- 3317 B9
- 3318 B9
- 3319 B9
- 3320 B9
- 3321 B9
- 3322 B9
- 3323 B9
- 3324 B9
- 3325 B9
- 3326 B9
- 3327 B9
- 3328 B9
- 3329 B9
- 3330 B9
- 3331 B9
- 3332 B9
- 3333 B9
- 3334 B9
- 3335 B9
- 3336 B9
- 3337 B9
- 3338 B9
- 3339 B9
- 3340 B9
- 3341 B9
- 3342 B9
- 3343 B9
- 3344 B9
- 3345 B9
- 3346 B9
- 3347 B9
- 3348 B9
- 3349 B9
- 3350 B9
- 3351 B9
- 3352 B9
- 3353 B9
- 3354 B9
- 3355 B9
- 3356 B9
- 3357 B9
- 3358 B9
- 3359 B9
- 3360 B9
- 3361 B9
- 3362 B9
- 3363 B9
- 3364 B9
- 3365 B9
- 3366 B9
- 3367 B9
- 3368 B9
- 3369 B9
- 3370 B9
- 3371 C2
- 3373 E10

CDR MAIN BOARD - CIRCUIT DIAGRAM 4 : MACE BE-PROCESSOR TESTPOINTS

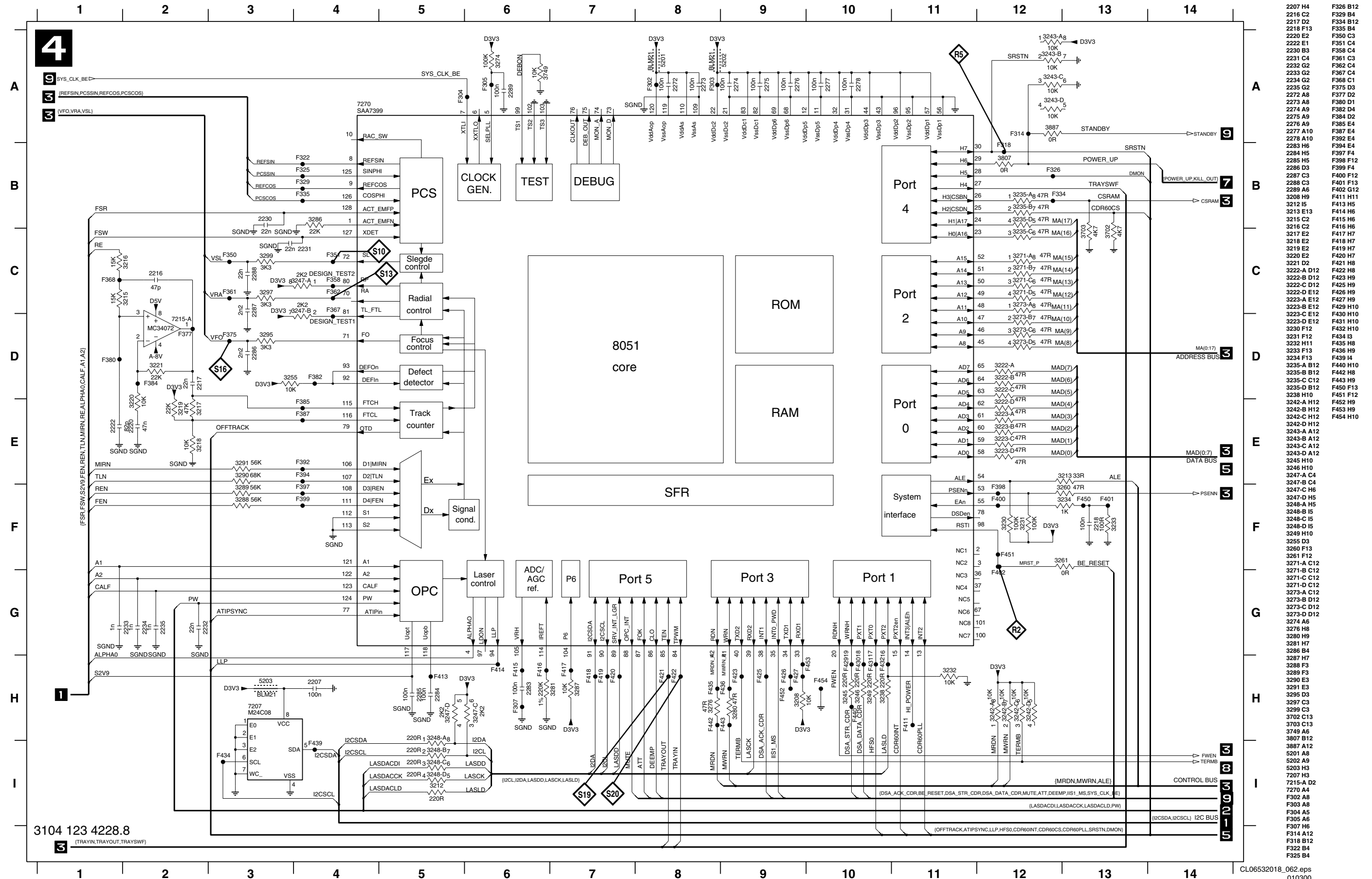

CDR MAIN BOARD - CIRCUIT DIAGRAM 5 : CD ENCODING-DECODING PART

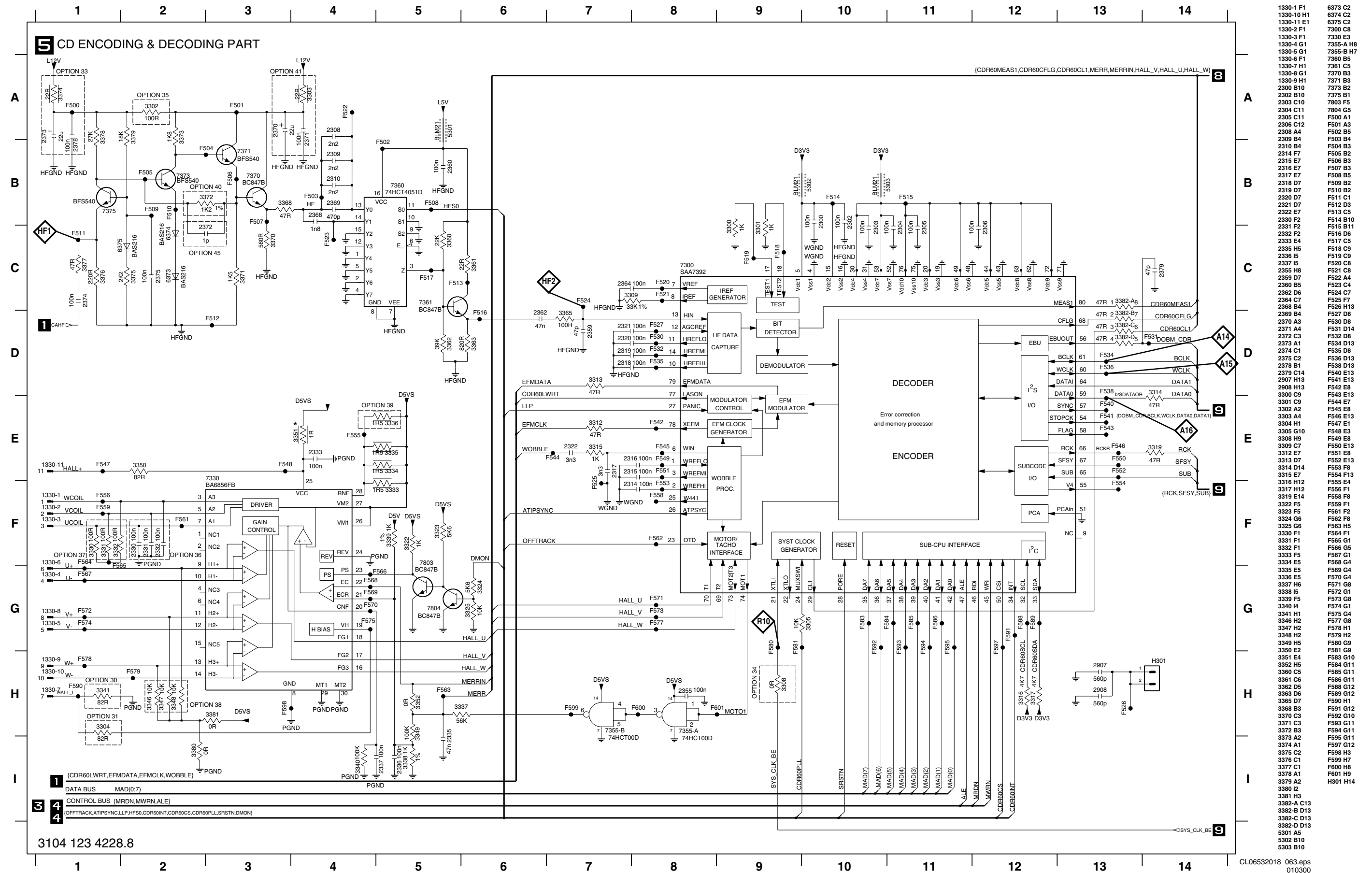

1330-1 F1	6373 C2
1330-10 H1	6374 C2
1330-11 E1	6375 C2
1330-2 F1	7300 C8
1330-3 F1	7330 E3
1330-4 G1	7355-A H8
1330-5 G1	7355-B H7
1330-6 F1	7357 B5
1330-7 H1	7361 C5
1330-8 G1	7370 B3
1330-9 H1	7371 B3
2300 B10	7373 B2
2302 B10	7375 B1
2303 C10	7803 F5
2304 C11	7804 G5
2305 C11	F500 A1
2306 C12	F501 A3
2308 A4	F502 B5
2309 B4	F503 B4
2310 B4	F504 B3
2314 F7	F505 B2
2315 E7	F506 B3
2316 E7	F507 B3
2317 E7	F508 B5
2318 D7	F509 B2
2319 D7	F510 B2
2320 D7	F511 C1
2321 D7	F512 D3
2322 E7	F513 C5
2330 F2	F514 B10
2331 F2	F515 B11
2332 F2	F516 D6
2333 E4	F517 C5
2335 H5	F518 C9
2336 I5	F519 C9
2337 I5	F520 C8
2355 H8	F521 C8
2359 D7	F522 A4
2360 B5	F523 C4
2362 D6	F524 C7
2364 C7	F525 F7
2368 B4	F526 H13
2369 B4	F527 D9
2370 A3	F530 D8
2371 A4	F531 D14
2372 C3	F532 D8
2373 A1	F534 D13
2374 C1	F535 D8
2375 C2	F536 D13
2378 B1	F538 D13
2379 C14	F540 E13
2397 H13	F541 E13
2908 H13	F542 E8
3300 C9	F543 E13
3301 C9	F544 E7
3302 A2	F545 E8
3303 A4	F546 E13
3304 H1	F547 E1
3305 G10	F548 E3
3308 H9	F549 E8
3309 C7	F550 E13
3312 E7	F551 E8
3313 D7	F552 E13
3314 D14	F553 F8
3315 E7	F554 F13
3316 H12	F555 E4
3317 H12	F556 F1
3319 E14	F558 F8
3322 F5	F559 F1
3323 F5	F561 F2
3324 G6	F562 F8
3325 G6	F563 H5
3330 F1	F564 F1
3331 F1	F565 G1
3332 F1	F566 G5
3333 F5	F567 G1
3334 E5	F568 G4
3335 E5	F569 G4
3336 E5	F570 G4
3337 H6	F571 G8
3338 I5	F572 G1
3339 F5	F573 G8
3340 I4	F574 G1
3341 H1	F575 G4
3342 H2	F577 G8
3343 H2	F578 H1
3344 H2	F579 H2
3349 H5	F580 G9
3350 E2	F581 G9
3351 E4	F583 G10
3352 H5	F584 G11
3360 C5	F585 G11
3361 C6	F586 G11
3362 D5	F588 G12
3363 D6	F589 G12
3365 D7	F590 H1
3368 B3	F591 G12
3370 C3	F592 G10
3371 C3	F593 G11
3372 B3	F594 G11
3373 A2	F595 G11
3374 A1	F597 G12
3375 C2	F598 H3
3376 C1	F599 H7
3377 C1	F600 H8
3378 A1	F601 H9
3379 A2	H301 H14
3380 I2	
3381 H3	
3382-A C13	
3382-B D13	
3382-C D13	
3382-D D13	
5301 A5	
5302 E10	
5303 B10	

CDR MAIN BOARD - CIRCUIT DIAGRAM 6 : AUDIO PART (NOT FOR CDR950/951)

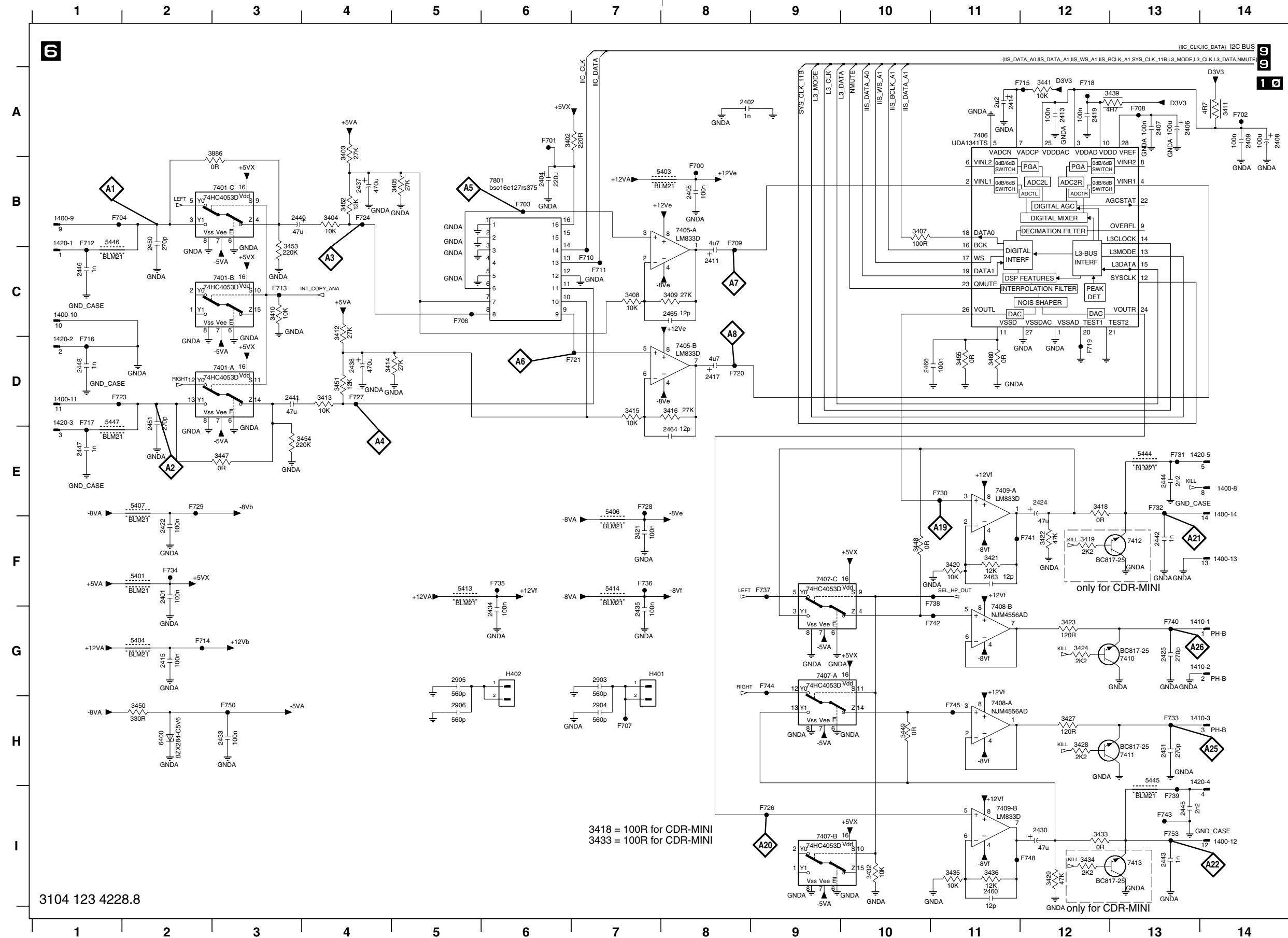

1400-10 C1	7405-B D8
1400-11 D1	7406 A11
1400-12 I14	7407-A G9
1400-13 F14	7407-B I9
1400-14 F14	7407-C F9
1400-5 E14	7408-A H11
1400-9 B1	7408-B G11
1410-1 G14	7409-A E11
1410-2 G14	7409-B I11
1410-3 H14	7410 G13
1420-1 B1	7411 H13
1420-2 D1	7412 F13
1420-3 D1	7413 H13
1420-4 H14	7801 B5
1420-5 E14	7700 B8
2401 F2	7701 A6
2402 A8	7702 A14
2404 B6	7703 B6
2405 B8	7704 B1
2406 A13	7705 C5
2407 A13	7707 H7
2408 A14	7708 A13
2409 A14	7709 B8
2411 C8	7710 C7
2413 A12	7711 C7
2414 A11	7712 B1
2415 G2	7713 C3
2417 D8	7714 G2
2419 A12	7715 A12
2421 F7	7716 D1
2422 F2	7717 D1
2424 E12	7718 A12
2425 G13	7719 D12
2430 I12	7720 D8
2431 H13	7721 D7
2433 H3	7723 D1
2434 G6	7724 B4
2435 G7	7725 G7
2437 B4	7727 D4
2438 D4	7728 E7
2440 B3	7729 E2
2441 D3	7730 E11
2442 F13	7731 E13
2443 I13	7732 E13
2444 E13	7733 H13
2445 I13	7734 F2
2446 C1	7735 F6
2447 E1	7736 F7
2448 D1	7737 F9
2450 B2	7738 F11
2451 D2	7739 I13
2460 I11	7740 G13
2463 F11	7741 F12
2464 E8	7742 G11
2465 C8	7743 I13
2466 D10	7744 G9
2903 G7	7745 H11
2904 H7	7746 H7
2905 G5	7750 H3
2906 H5	7753 I13
3402 A6	H401 G7
3403 A4	H402 G6
3404 B4	
3405 B5	
3407 B10	
3408 C7	
3409 C8	
3410 C3	
3411 A14	
3412 C4	
3413 D4	
3414 D4	
3415 D7	
3416 D8	
3418 E12	
3419 F12	
3420 F11	
3421 F11	
3422 F12	
3423 G12	
3424 G12	
3427 H12	
3428 H12	
3429 I12	
3432 I10	
3433 H12	
3434 I12	
3435 I11	
3436 I11	
3439 A13	
3441 A12	
3447 E3	
3448 F10	
3449 H10	
3450 H2	
3451 D4	
3452 B4	
3453 B3	
3454 E4	
3455 D11	
3459 D11	
3886 A3	
5401 F2	
5403 B8	
5404 G2	
5406 E7	
5407 E2	
5413 F5	
5414 F7	
5444 E13	
5445 H13	
5446 B1	
5447 D1	
6400 H2	
7401-A D3	
7401-B C3	
7401-C B3	
7405-A B8	

3104 123 4228.8

CDR MAIN BOARD - CIRCUIT DIAGRAM 7 : POWER PART TESTPOINTS

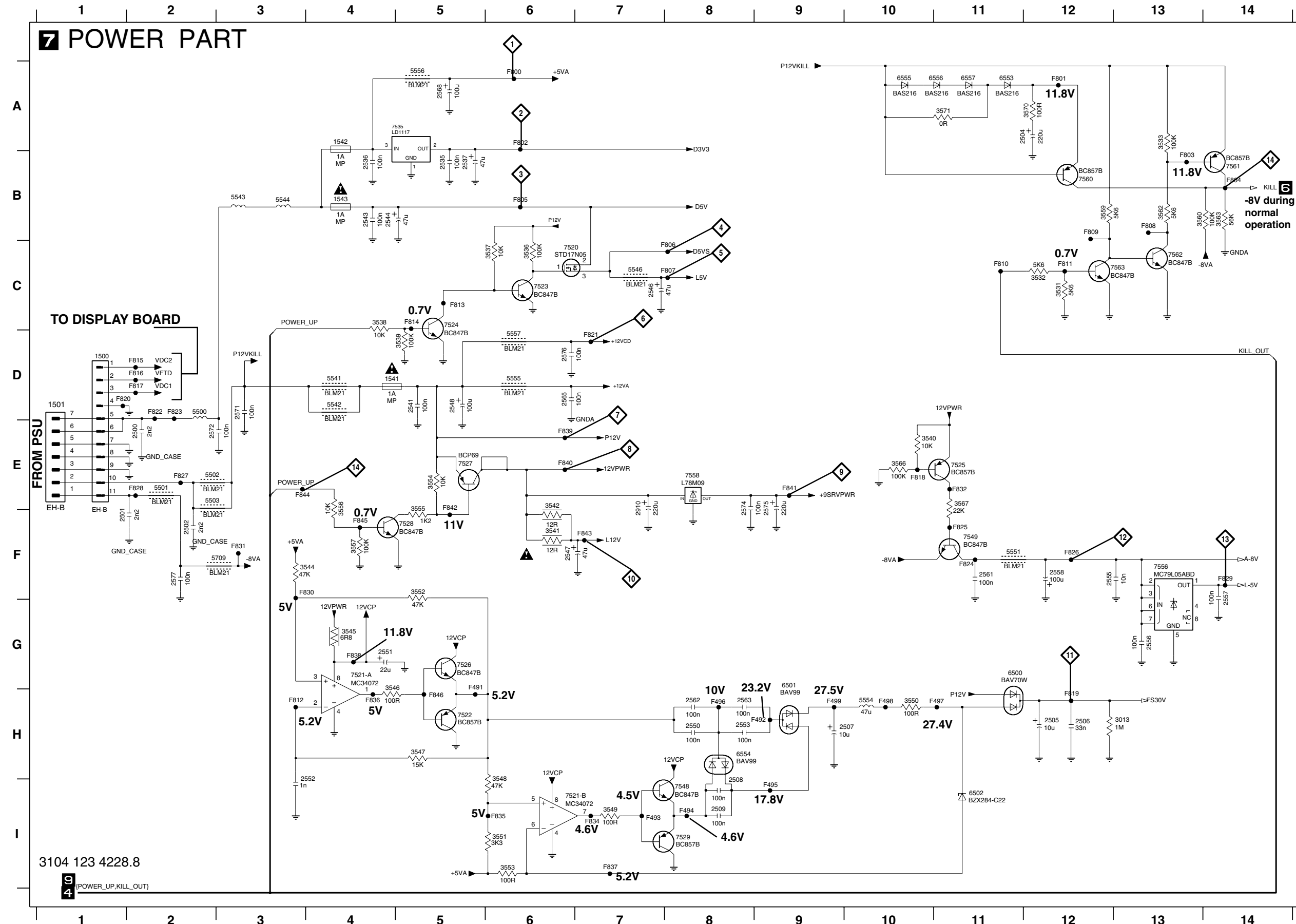

- 1500 D1
- 1541 D4
- 1542 A4
- 1543 B4
- 2500 E2
- 2501 F1
- 2502 F2
- F496 H8
- 2504 A12
- 2505 H12
- 2506 H12
- 2507 H10
- 2508 I8
- 2509 I8
- 2535 B5
- 2536 B4
- 2537 B5
- 2541 D5
- 2543 B4
- 2544 B4
- 2546 C7
- 2547 F6
- 2548 D5
- 2550 H8
- 2551 G4
- 2552 H4
- 2553 H8
- 2555 F12
- 2556 G13
- 2557 F14
- 2558 F12
- 2561 F11
- 2562 H8
- 2563 H8
- 2565 D6
- 2568 A5
- 2571 D3
- 2572 E2
- 2574 E8
- 2575 E9
- 2576 D6
- 2577 F2
- 2910 E7
- 3013 H13
- 3531 C12
- 3532 C12
- 3533 A13
- 3536 C6
- 3537 C6
- 3538 C4
- 3539 D5
- 3540 E10
- 3541 F6
- 3542 E6
- 3544 F4
- 3545 G4
- 3546 H4
- 3547 H5
- 3548 H6
- 3549 I7
- 3550 H10
- 3551 I6
- 3552 F5
- 3553 I6
- 3554 E5
- 3555 F5
- 3556 E4
- 3557 F4
- 3559 B12
- 3560 B13
- 3562 B13
- 3563 B14
- 3566 E10
- 3567 E11
- 3570 A12
- 3571 A11
- 5500 D2
- 5501 E2
- 5502 E2
- 5503 E2
- 5541 D4
- 5542 D4
- 5543 B3
- 5544 B3
- 5546 C7
- 5551 F11
- 5554 H10
- 5555 D6
- 5556 A5
- 5557 D6
- 5709 F3
- 6500 G11
- 6501 G9
- 6502 I11
- 6553 A11
- 6554 H8
- 6555 A10
- 6556 A11
- 6557 A11
- 7520 C6
- 7521-A G4
- 7521-B I6
- 7522 H5
- 7523 C6
- 7524 C5
- 7525 E11
- 7526 G5
- 7527 E5
- 7528 F5
- 7529 I8
- 7535 A4
- 7548 I8
- 7549 F11
- 7556 F13
- 7558 E8
- 7560 B12
- 7561 B14
- 7562 C13
- 7563 C12
- F491 H5
- F492 H9
- F493 I7
- F494 I8
- F495 I9
- F496 H8
- F497 H11
- F498 H10
- F499 H9
- F800 A6
- F801 A12
- F802 A6
- F803 B13
- F804 B14
- F805 B6
- F806 C8
- F807 C8
- F808 B13
- F809 B12
- F810 C11
- F811 C12
- F812 H3
- F813 C5
- F814 C5
- F815 D2
- F816 D2
- F817 D2
- F818 H10
- F819 H12
- F820 D1
- F821 D7
- F822 D2
- F823 D2
- F824 F11
- F825 F11
- F826 F12
- F827 E2
- F828 E2
- F829 F14
- F830 F4
- F831 F3
- F832 E11
- F834 I7
- F835 I6
- F836 H4
- F837 I7
- F838 G4
- F839 E6
- F840 E6
- F841 E9
- F842 F5
- F843 F7
- F844 E3
- F845 F4
- F846 H5

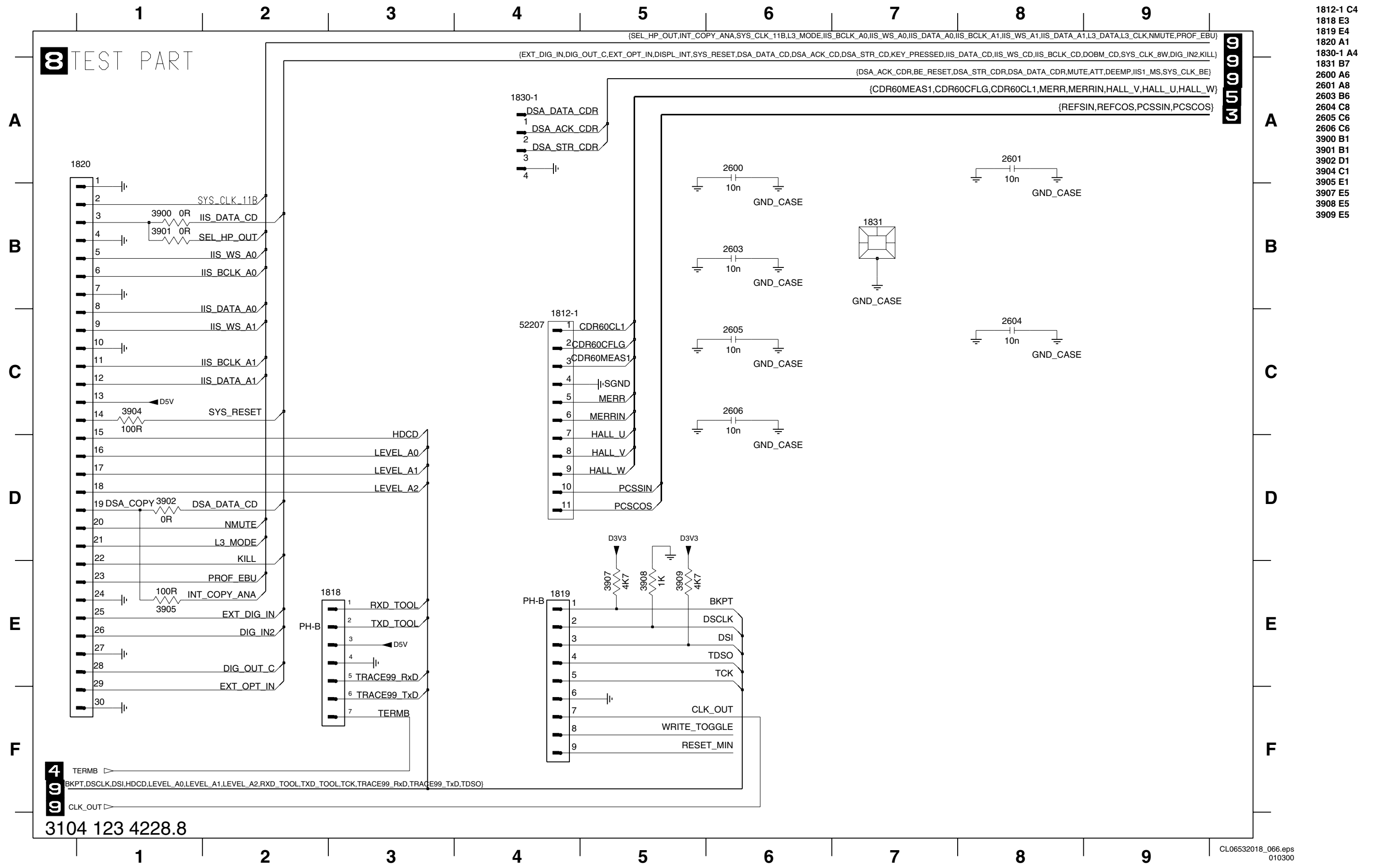

- 1812-1 C4
- 1818 E3
- 1819 E4
- 1820 A1
- 1830-1 A4
- 1831 B7
- 2600 A6
- 2601 A8
- 2603 B6
- 2604 C8
- 2605 C6
- 2606 C6
- 3900 B1
- 3901 B1
- 3902 D1
- 3904 C1
- 3905 E1
- 3907 E5
- 3908 E5
- 3909 E5

CDR MAIN BOARD - CIRCUIT DIAGRAM 9 : DASP MASTER PROCESSOR TESTPOINTS

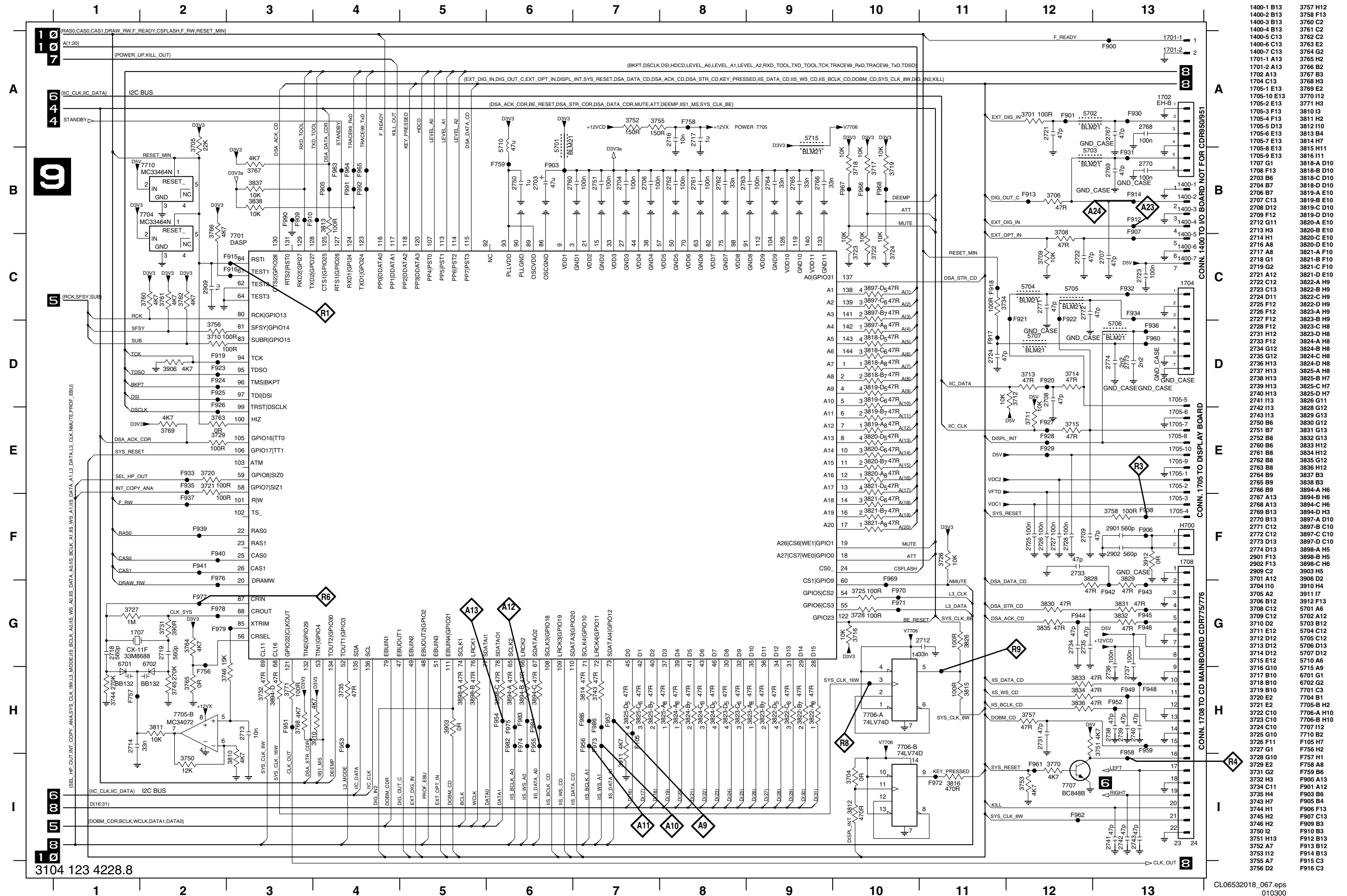

3104 123 4228.8

CDR MAIN BOARD - CIRCUIT DIAGRAM 10 : DASP FLASH & DRAM TESTPOINTS

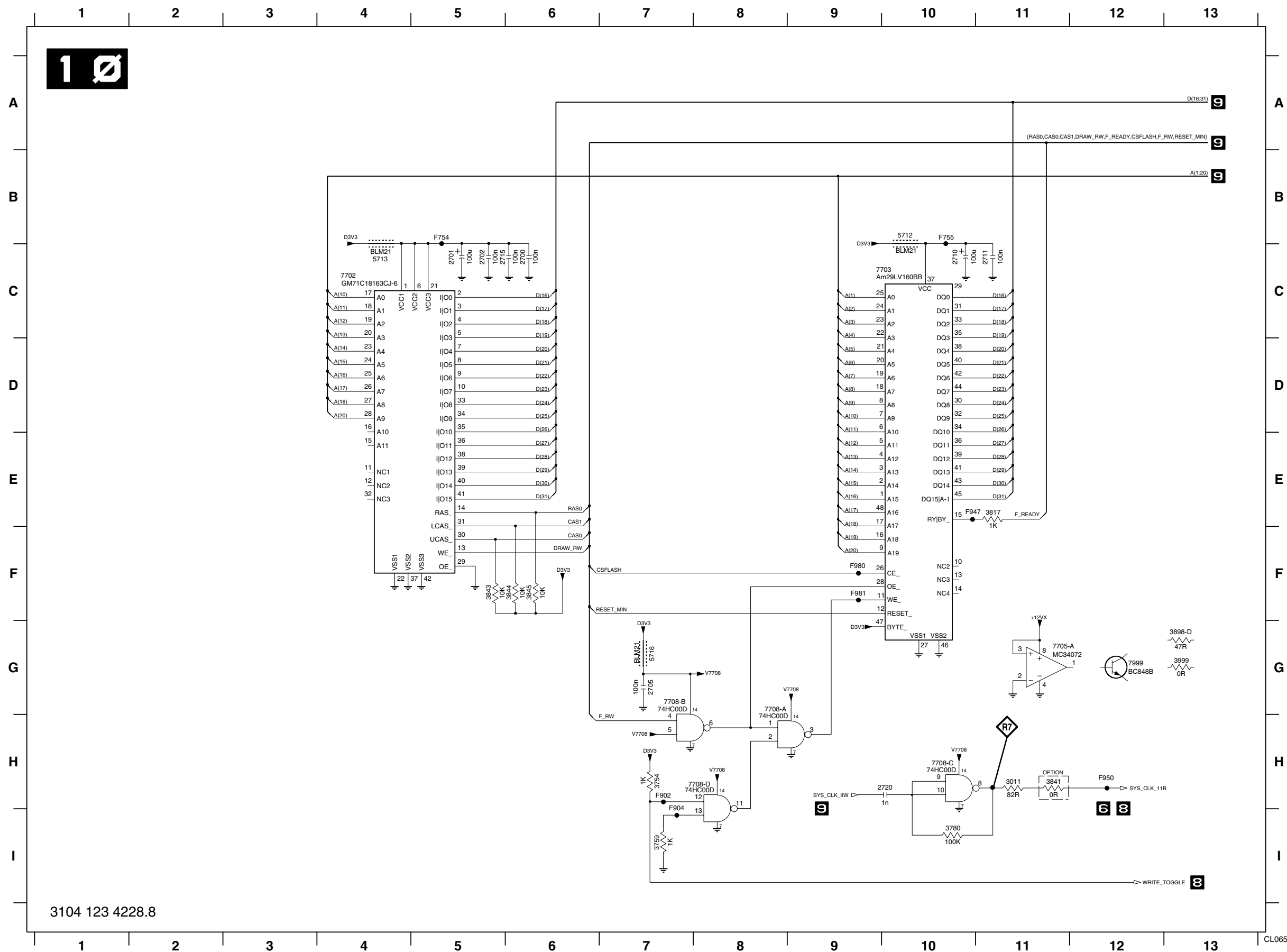

- 2700 C6
- 2701 C5
- 2702 C5
- 2705 G7
- 2710 C10
- 2711 C11
- 2715 C5
- 2720 H10
- 3011 H11
- 3754 H7
- 3759 I7
- 3780 H10
- 3817 E11
- 3841 H11
- 3843 F5
- 3844 F6
- 3845 F6
- 3898-D G13
- 3999 G13
- 5712 B10
- 5713 C4
- 5716 G7
- 7702 C4
- 7703 C9
- 7705-A G11
- 7708-A G8
- 7708-B G7
- 7708-C H10
- 7708-D H7
- 7999 G12
- F754 B5
- F755 B10
- F902 H7
- F904 I7
- F947 E10
- F950 H12
- F980 F9
- F981 F9

3104 123 4228.8

CDR MAIN BOARD .8 - BOTTOM VIEW

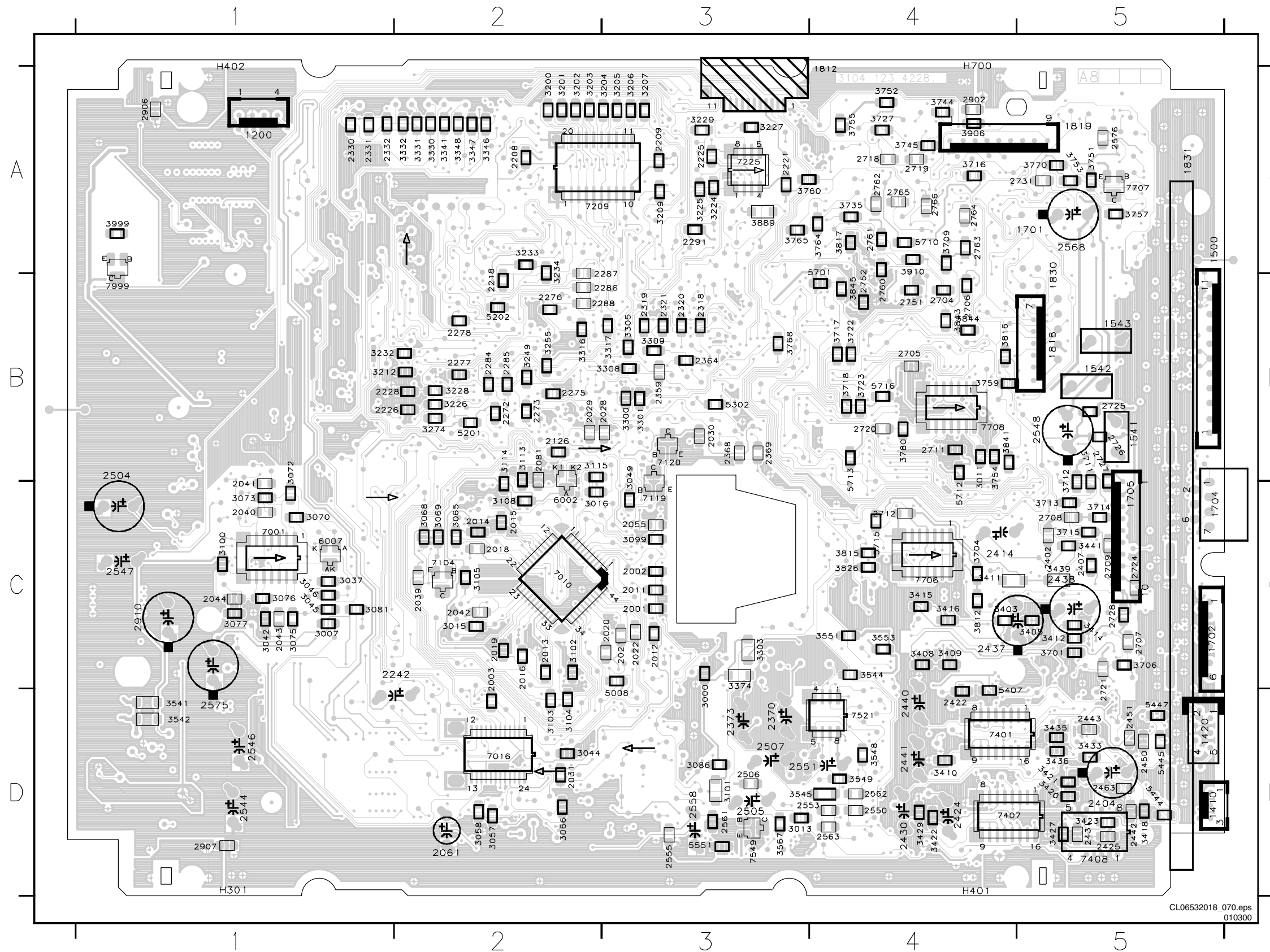

271	272	273	274	275	276	277	278	279	280	281	282	283	284	285	286	287	288	289	290	291	292	293	294	295	296	297	298	299	300	301	302	303	304	305	306	307	308	309	310	311	312	313	314	315	316	317	318	319	320	321	322	323	324	325	326	327	328	329	330	331	332	333	334	335	336	337	338	339	340	341	342	343	344	345	346	347	348	349	350	351	352	353	354	355	356	357	358	359	360	361	362	363	364	365	366	367	368	369	370	371	372	373	374	375	376	377	378	379	380	381	382	383	384	385	386	387	388	389	390	391	392	393	394	395	396	397	398	399	400	401	402	403	404	405	406	407	408	409	410	411	412	413	414	415	416	417	418	419	420	421	422	423	424	425	426	427	428	429	430	431	432	433	434	435	436	437	438	439	440	441	442	443	444	445	446	447	448	449	450	451	452	453	454	455	456	457	458	459	460	461	462	463	464	465	466	467	468	469	470	471	472	473	474	475	476	477	478	479	480	481	482	483	484	485	486	487	488	489	490	491	492	493	494	495	496	497	498	499	500	501	502	503	504	505	506	507	508	509	510	511	512	513	514	515	516	517	518	519	520	521	522	523	524	525	526	527	528	529	530	531	532	533	534	535	536	537	538	539	540	541	542	543	544	545	546	547	548	549	550	551	552	553	554	555	556	557	558	559	560	561	562	563	564	565	566	567	568	569	570	571	572	573	574	575	576	577	578	579	580	581	582	583	584	585	586	587	588	589	590	591	592	593	594	595	596	597	598	599	600	601	602	603	604	605	606	607	608	609	610	611	612	613	614	615	616	617	618	619	620	621	622	623	624	625	626	627	628	629	630	631	632	633	634	635	636	637	638	639	640	641	642	643	644	645	646	647	648	649	650	651	652	653	654	655	656	657	658	659	660	661	662	663	664	665	666	667	668	669	670	671	672	673	674	675	676	677	678	679	680	681	682	683	684	685	686	687	688	689	690	691	692	693	694	695	696	697	698	699	700	701	702	703	704	705	706	707	708	709	710	711	712	713	714	715	716	717	718	719	720	721	722	723	724	725	726	727	728	729	730	731	732	733	734	735	736	737	738	739	740	741	742	743	744	745	746	747	748	749	750	751	752	753	754	755	756	757	758	759	760	761	762	763	764	765	766	767	768	769	770	771	772	773	774	775	776	777	778	779	780	781	782	783	784	785	786	787	788	789	790	791	792	793	794	795	796	797	798	799	800	801	802	803	804	805	806	807	808	809	810	811	812	813	814	815	816	817	818	819	820	821	822	823	824	825	826	827	828	829	830	831	832	833	834	835	836	837	838	839	840	841	842	843	844	845	846	847	848	849	850	851	852	853	854	855	856	857	858	859	860	861	862	863	864	865	866	867	868	869	870	871	872	873	874	875	876	877	878	879	880	881	882	883	884	885	886	887	888	889	890	891	892	893	894	895	896	897	898	899	900	901	902	903	904	905	906	907	908	909	910	911	912	913	914	915	916	917	918	919	920	921	922	923	924	925	926	927	928	929	930	931	932	933	934	935	936	937	938	939	940	941	942	943	944	945	946	947	948	949	950	951	952	953	954	955	956	957	958	959	960	961	962	963	964	965	966	967	968	969	970	971	972	973	974	975	976	977	978	979	980	981	982	983	984	985	986	987	988	989	990	991	992	993	994	995	996	997	998	999	1000
-----	-----	-----	-----	-----	-----	-----	-----	-----	-----	-----	-----	-----	-----	-----	-----	-----	-----	-----	-----	-----	-----	-----	-----	-----	-----	-----	-----	-----	-----	-----	-----	-----	-----	-----	-----	-----	-----	-----	-----	-----	-----	-----	-----	-----	-----	-----	-----	-----	-----	-----	-----	-----	-----	-----	-----	-----	-----	-----	-----	-----	-----	-----	-----	-----	-----	-----	-----	-----	-----	-----	-----	-----	-----	-----	-----	-----	-----	-----	-----	-----	-----	-----	-----	-----	-----	-----	-----	-----	-----	-----	-----	-----	-----	-----	-----	-----	-----	-----	-----	-----	-----	-----	-----	-----	-----	-----	-----	-----	-----	-----	-----	-----	-----	-----	-----	-----	-----	-----	-----	-----	-----	-----	-----	-----	-----	-----	-----	-----	-----	-----	-----	-----	-----	-----	-----	-----	-----	-----	-----	-----	-----	-----	-----	-----	-----	-----	-----	-----	-----	-----	-----	-----	-----	-----	-----	-----	-----	-----	-----	-----	-----	-----	-----	-----	-----	-----	-----	-----	-----	-----	-----	-----	-----	-----	-----	-----	-----	-----	-----	-----	-----	-----	-----	-----	-----	-----	-----	-----	-----	-----	-----	-----	-----	-----	-----	-----	-----	-----	-----	-----	-----	-----	-----	-----	-----	-----	-----	-----	-----	-----	-----	-----	-----	-----	-----	-----	-----	-----	-----	-----	-----	-----	-----	-----	-----	-----	-----	-----	-----	-----	-----	-----	-----	-----	-----	-----	-----	-----	-----	-----	-----	-----	-----	-----	-----	-----	-----	-----	-----	-----	-----	-----	-----	-----	-----	-----	-----	-----	-----	-----	-----	-----	-----	-----	-----	-----	-----	-----	-----	-----	-----	-----	-----	-----	-----	-----	-----	-----	-----	-----	-----	-----	-----	-----	-----	-----	-----	-----	-----	-----	-----	-----	-----	-----	-----	-----	-----	-----	-----	-----	-----	-----	-----	-----	-----	-----	-----	-----	-----	-----	-----	-----	-----	-----	-----	-----	-----	-----	-----	-----	-----	-----	-----	-----	-----	-----	-----	-----	-----	-----	-----	-----	-----	-----	-----	-----	-----	-----	-----	-----	-----	-----	-----	-----	-----	-----	-----	-----	-----	-----	-----	-----	-----	-----	-----	-----	-----	-----	-----	-----	-----	-----	-----	-----	-----	-----	-----	-----	-----	-----	-----	-----	-----	-----	-----	-----	-----	-----	-----	-----	-----	-----	-----	-----	-----	-----	-----	-----	-----	-----	-----	-----	-----	-----	-----	-----	-----	-----	-----	-----	-----	-----	-----	-----	-----	-----	-----	-----	-----	-----	-----	-----	-----	-----	-----	-----	-----	-----	-----	-----	-----	-----	-----	-----	-----	-----	-----	-----	-----	-----	-----	-----	-----	-----	-----	-----	-----	-----	-----	-----	-----	-----	-----	-----	-----	-----	-----	-----	-----	-----	-----	-----	-----	-----	-----	-----	-----	-----	-----	-----	-----	-----	-----	-----	-----	-----	-----	-----	-----	-----	-----	-----	-----	-----	-----	-----	-----	-----	-----	-----	-----	-----	-----	-----	-----	-----	-----	-----	-----	-----	-----	-----	-----	-----	-----	-----	-----	-----	-----	-----	-----	-----	-----	-----	-----	-----	-----	-----	-----	-----	-----	-----	-----	-----	-----	-----	-----	-----	-----	-----	-----	-----	-----	-----	-----	-----	-----	-----	-----	-----	-----	-----	-----	-----	-----	-----	-----	-----	-----	-----	-----	-----	-----	-----	-----	-----	-----	-----	-----	-----	-----	-----	-----	-----	-----	-----	-----	-----	-----	-----	-----	-----	-----	-----	-----	-----	-----	-----	-----	-----	-----	-----	-----	-----	-----	-----	-----	-----	-----	-----	-----	-----	-----	-----	-----	-----	-----	-----	-----	-----	-----	-----	-----	-----	-----	-----	-----	-----	-----	-----	-----	-----	-----	-----	-----	-----	-----	-----	-----	-----	-----	-----	-----	-----	-----	-----	-----	-----	-----	-----	-----	-----	-----	-----	-----	-----	-----	-----	-----	-----	-----	-----	-----	-----	-----	-----	-----	-----	-----	-----	-----	-----	-----	-----	-----	-----	-----	-----	-----	-----	-----	-----	-----	-----	-----	-----	-----	-----	-----	-----	-----	-----	-----	-----	-----	-----	-----	-----	-----	-----	-----	-----	-----	-----	-----	-----	-----	-----	-----	-----	-----	-----	-----	-----	-----	-----	-----	-----	-----	-----	-----	-----	-----	-----	-----	-----	-----	-----	-----	-----	-----	-----	-----	-----	-----	-----	-----	-----	-----	-----	-----	-----	-----	-----	-----	-----	-----	-----	-----	-----	-----	-----	-----	-----	-----	-----	-----	-----	------

CDR-Mainboard PWB testpoints

CDR MAIN BOARD - BOTTOM VIEW : POWER PART TESTPOINTS

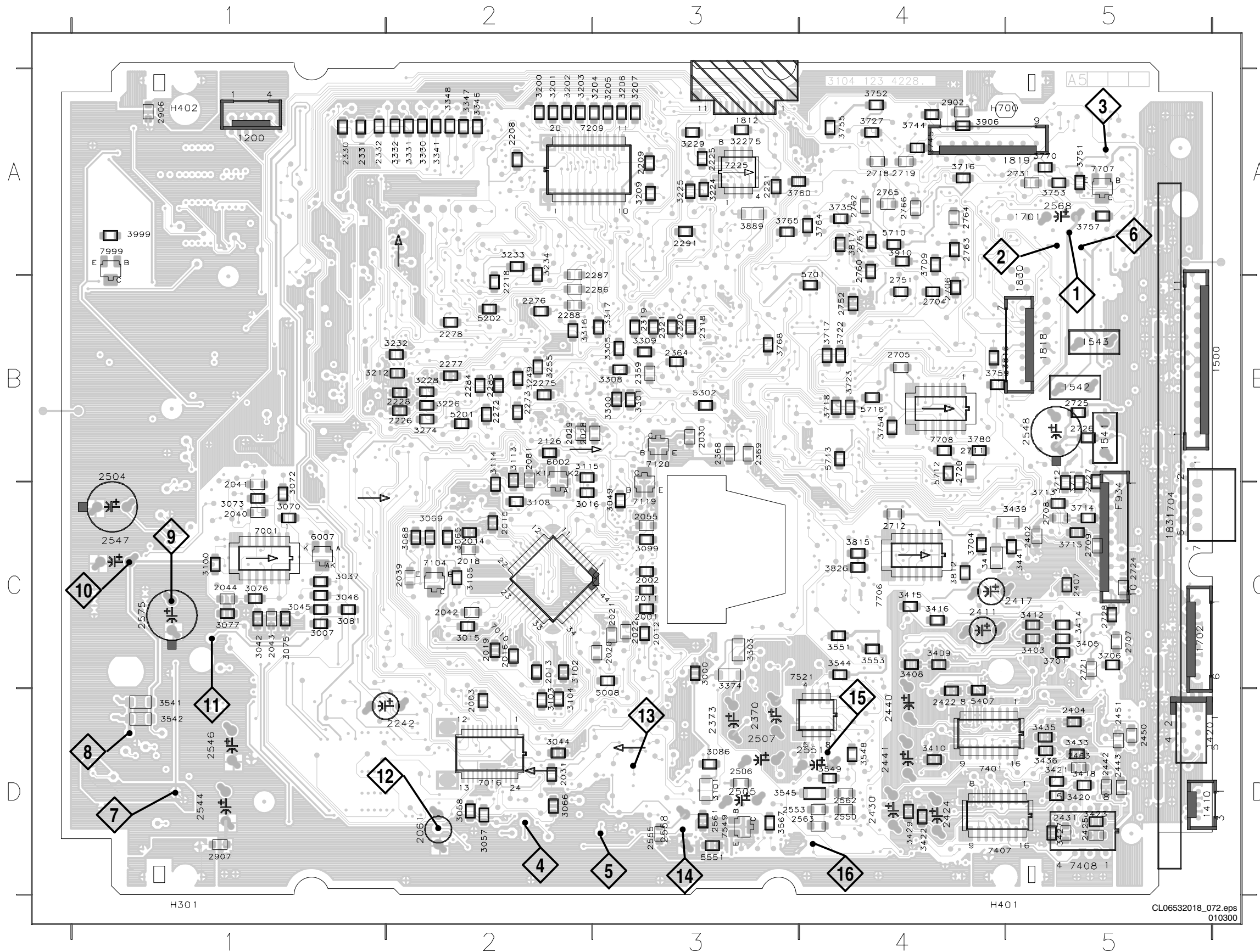

1	A2
2	A2
3	A2
4	A2
5	A2
6	A2
7	A2
8	A2
9	A2
10	A2
11	A2
12	A2
13	A2
14	A2
15	A2
16	A2
1	A4
2	A4
3	A4
4	A4
5	A4
6	A4
7	A4
8	A4
9	A4
10	A4
11	A4
12	A4
13	A4
14	A4
15	A4
16	A4
1	A6
2	A6
3	A6
4	A6
5	A6
6	A6
7	A6
8	A6
9	A6
10	A6
11	A6
12	A6
13	A6
14	A6
15	A6
16	A6
1	A8
2	A8
3	A8
4	A8
5	A8
6	A8
7	A8
8	A8
9	A8
10	A8
11	A8
12	A8
13	A8
14	A8
15	A8
16	A8
1	A10
2	A10
3	A10
4	A10
5	A10
6	A10
7	A10
8	A10
9	A10
10	A10
11	A10
12	A10
13	A10
14	A10
15	A10
16	A10
1	A12
2	A12
3	A12
4	A12
5	A12
6	A12
7	A12
8	A12
9	A12
10	A12
11	A12
12	A12
13	A12
14	A12
15	A12
16	A12
1	A14
2	A14
3	A14
4	A14
5	A14
6	A14
7	A14
8	A14
9	A14
10	A14
11	A14
12	A14
13	A14
14	A14
15	A14
16	A14
1	A16
2	A16
3	A16
4	A16
5	A16
6	A16
7	A16
8	A16
9	A16
10	A16
11	A16
12	A16
13	A16
14	A16
15	A16
16	A16
1	A18
2	A18
3	A18
4	A18
5	A18
6	A18
7	A18
8	A18
9	A18
10	A18
11	A18
12	A18
13	A18
14	A18
15	A18
16	A18
1	A20
2	A20
3	A20
4	A20
5	A20
6	A20
7	A20
8	A20
9	A20
10	A20
11	A20
12	A20
13	A20
14	A20
15	A20
16	A20
1	A22
2	A22
3	A22
4	A22
5	A22
6	A22
7	A22
8	A22
9	A22
10	A22
11	A22
12	A22
13	A22
14	A22
15	A22
16	A22
1	A24
2	A24
3	A24
4	A24
5	A24
6	A24
7	A24
8	A24
9	A24
10	A24
11	A24
12	A24
13	A24
14	A24
15	A24
16	A24
1	A26
2	A26
3	A26
4	A26
5	A26
6	A26
7	A26
8	A26
9	A26
10	A26
11	A26
12	A26
13	A26
14	A26
15	A26
16	A26
1	A28
2	A28
3	A28
4	A28
5	A28
6	A28
7	A28
8	A28
9	A28
10	A28
11	A28
12	A28
13	A28
14	A28
15	A28
16	A28
1	A30
2	A30
3	A30
4	A30
5	A30
6	A30
7	A30
8	A30
9	A30
10	A30
11	A30
12	A30
13	A30
14	A30
15	A30
16	A30
1	A32
2	A32
3	A32
4	A32
5	A32
6	A32
7	A32
8	A32
9	A32
10	A32
11	A32
12	A32
13	A32
14	A32
15	A32
16	A32
1	A34
2	A34
3	A34
4	A34
5	A34
6	A34
7	A34
8	A34
9	A34
10	A34
11	A34
12	A34
13	A34
14	A34
15	A34
16	A34
1	A36
2	A36
3	A36
4	A36
5	A36
6	A36
7	A36
8	A36
9	A36
10	A36
11	A36
12	A36
13	A36
14	A36
15	A36
16	A36
1	A38
2	A38
3	A38
4	A38
5	A38
6	A38
7	A38
8	A38
9	A38
10	A38
11	A38
12	A38
13	A38
14	A38
15	A38
16	A38
1	A40
2	A40
3	A40
4	A40
5	A40
6	A40
7	A40
8	A40
9	A40
10	A40
11	A40
12	A40
13	A40
14	A40
15	A40
16	A40
1	A42
2	A42
3	A42
4	A42
5	A42
6	A42
7	A42
8	A42
9	A42
10	A42
11	A42
12	A42
13	A42
14	A42
15	A42
16	A42
1	A44
2	A44
3	A44
4	A44
5	A44
6	A44
7	A44
8	A44
9	A44
10	A44
11	A44
12	A44
13	A44
14	A44
15	A44
16	A44
1	A46
2	A46
3	A46
4	A46
5	A46
6	A46
7	A46
8	A46
9	A46
10	A46
11	A46
12	A46
13	A46
14	A46
15	A46
16	A46
1	A48
2	A48
3	A48
4	A48
5	A48
6	A48
7	A48
8	A48
9	A48
10	A48
11	A48
12	A48
13	A48
14	A48
15	A48
16	A48
1	A50
2	A50
3	A50
4	A50
5	A50
6	A50
7	A50
8	A50
9	A50
10	A50
11	A50
12	A50
13	A50
14	A50
15	A50
16	A50
1	A52
2	A52
3	A52
4	A52
5	A52
6	A52
7	A52
8	A52
9	A52
10	A52
11	A52
12	A52
13	A52
14	A52
15	A52
16	A52
1	A54
2	A54
3	A54
4	A54
5	A54
6	A54
7	A54
8	A54
9	A54
10	A54
11	A54
12	A54
13	A54
14	A54
15	A54
16	A54
1	A56
2	A56
3	A56
4	A56
5	A56
6	A56
7	A56
8	A56
9	A56
10	A56
11	A56
12	A56
13	A56
14	A56
15	A56
16	A56
1	A58
2	A58
3	A58
4	A58
5	A58
6	A58
7	A58
8	A58
9	A58
10	A58
11	A58
12	A58
13	A58
14	A58
15	A58
16	A58
1	A60
2	A60
3	A60
4	A60
5	A60
6	A60
7	A60
8	A60
9	A60
10	A60
11	A60
12	A60
13	A60
14	A60
15	A60
16	A60
1	A62
2	A62
3	A62
4	A62
5	A62
6	A62
7	A62
8	A62
9	A62
10	A62
11	A62
12	A62
13	A62
14	A62
15	A62
16	A62
1	A64
2	A64
3	A64
4	A64
5	A64
6	A64
7	A64
8	A64
9	A64
10	A64
11	A64
12	A64
13	A64
14	A64
15	A64
16	A64
1	A66
2	A66
3	A66
4	A66
5	A66
6	A66
7	A66
8	A66
9	A66
10	A66
11	A66
12	A66
13	A66
14	A66
15	A66
16	A66
1	A68
2	A68
3	A68
4	A68
5	A68
6	A68
7	A68
8	A68
9	A68
10	A68
11	A68
12	A68
13	A68
14	A68
15	A68
16	A68
1	A70
2	A70
3	A70
4	A70
5	A70
6	A70
7	A70
8	A70
9	A70
10	A70
11	A70
12	A70
13	A70
14	A70
15	A70
16	A70
1	A72
2	A72
3	A72
4	A72
5	A72
6	A72
7	A72
8	A72
9	A72
10	A72
11	A72
12	A72
13	A72
14	A72
15	A72
16	A72
1	A74
2	A74
3	A74
4	A74
5	A74
6	A74
7	A74
8	A74
9	A74
10	A74
11	A74
12	A74
13	A74
14	A74
15	A74
16	A74
1	A76
2	A76
3	A76
4	A76
5	A76
6	A76
7	A76
8	A76
9	A76
10	A76
11	A76
12	A76
13	A76
14	A76
15	A76
16	A76
1	A78
2	A78
3	A78
4	A78
5	A78
6	A78
7	A78
8	A78
9	A78
10	A78
11	A78
12	A78
13	A78
14	A78
15	A78
16	A78
1	A80
2	A80
3	A80
4	A80
5	A80
6	A80
7	A80
8	A80
9	A80
10	A80
11	A80
12	A80
13	A80
14	A80
15	A80
16	A80
1	A82
2	A82
3	A82
4	A82
5	A82
6	A82
7	A82
8	A82
9	A82
10	A82
11	A82
12	A82
13	A82
14	A82
15	A82
16	A82
1	A84
2	A84
3	A84
4	A84
5	A84
6	A84
7	A84
8	A84
9	A84
10	A84
11	A84
12	A84
13	A84
14	A84
15	A84
16	A84
1	A86
2	A86
3	A86
4	A86
5	A86
6	A86
7	A86
8	A86
9	A86
10	A86
11	A86
12	A86
13	A86
14	A86
15	A86
16	

CDR MAIN BOARD - BOTTOM VIEW : RESET & CLOCK TESTPOINTS

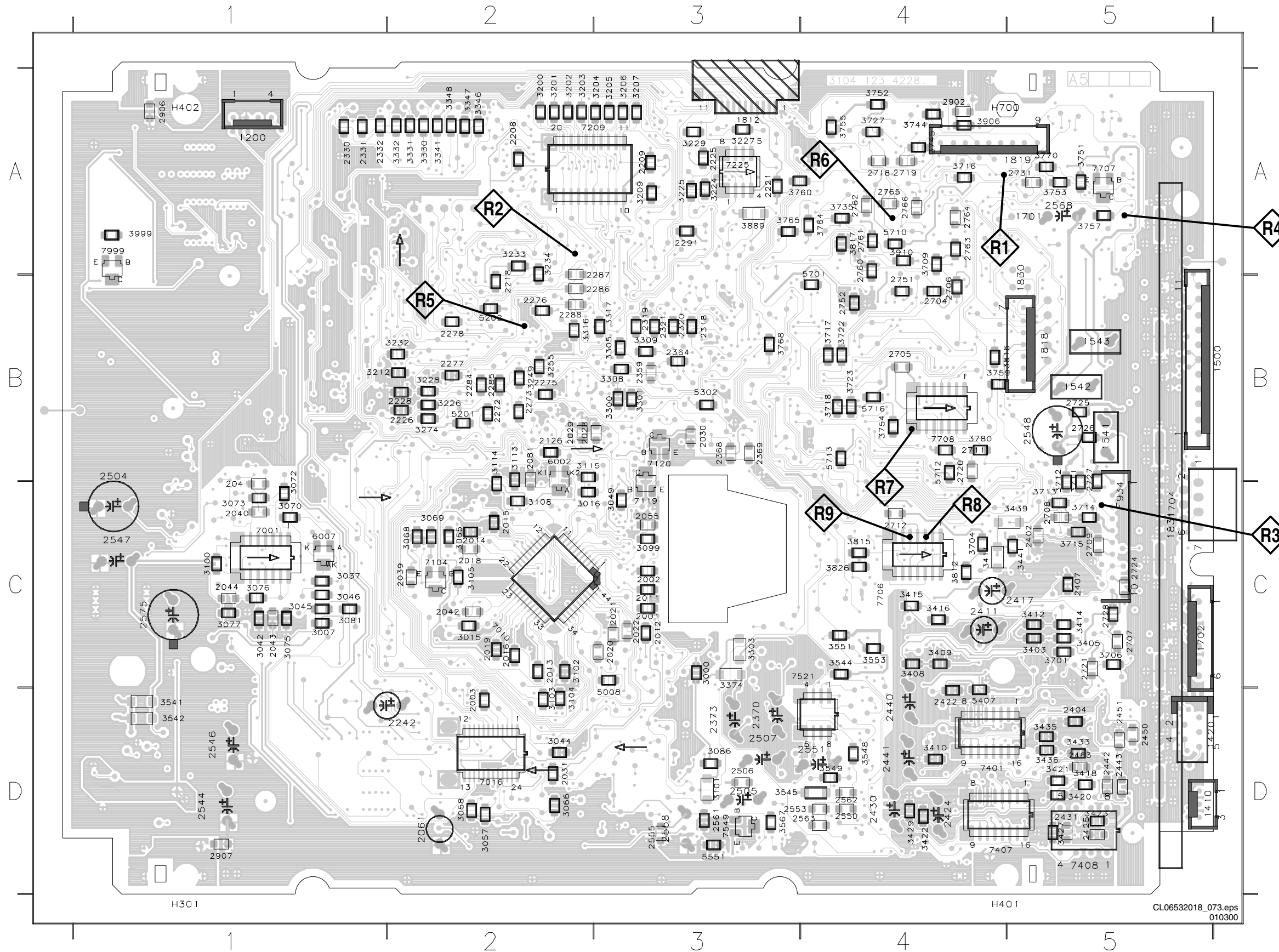

18	2720	A2	57	12	B4
19	2721	A2	58	13	B4
20	2722	A2	59	14	B4
21	2723	A2	60	15	B4
22	2724	A2	61	16	B4
23	2725	A2	62	17	B4
24	2726	A2	63	18	B4
25	2727	A2	64	19	B4
26	2728	A2	65	20	B4
27	2729	A2	66	21	B4
28	2730	A2	67	22	B4
29	2731	A2	68	23	B4
30	2732	A2	69	24	B4
31	2733	A2	70	25	B4
32	2734	A2	71	26	B4
33	2735	A2	72	27	B4
34	2736	A2	73	28	B4
35	2737	A2	74	29	B4
36	2738	A2	75	30	B4
37	2739	A2	76	31	B4
38	2740	A2	77	32	B4
39	2741	A2	78	33	B4
40	2742	A2	79	34	B4
41	2743	A2	80	35	B4
42	2744	A2	81	36	B4
43	2745	A2	82	37	B4
44	2746	A2	83	38	B4
45	2747	A2	84	39	B4
46	2748	A2	85	40	B4
47	2749	A2	86	41	B4
48	2750	A2	87	42	B4
49	2751	A2	88	43	B4
50	2752	A2	89	44	B4
51	2753	A2	90	45	B4
52	2754	A2	91	46	B4
53	2755	A2	92	47	B4
54	2756	A2	93	48	B4
55	2757	A2	94	49	B4
56	2758	A2	95	50	B4
57	2759	A2	96	51	B4
58	2760	A2	97	52	B4
59	2761	A2	98	53	B4
60	2762	A2	99	54	B4
61	2763	A2	100	55	B4
62	2764	A2	101	56	B4
63	2765	A2	102	57	B4
64	2766	A2	103	58	B4
65	2767	A2	104	59	B4
66	2768	A2	105	60	B4
67	2769	A2	106	61	B4
68	2770	A2	107	62	B4
69	2771	A2	108	63	B4
70	2772	A2	109	64	B4
71	2773	A2	110	65	B4
72	2774	A2	111	66	B4
73	2775	A2	112	67	B4
74	2776	A2	113	68	B4
75	2777	A2	114	69	B4
76	2778	A2	115	70	B4
77	2779	A2	116	71	B4
78	2780	A2	117	72	B4
79	2781	A2	118	73	B4
80	2782	A2	119	74	B4
81	2783	A2	120	75	B4
82	2784	A2	121	76	B4
83	2785	A2	122	77	B4
84	2786	A2	123	78	B4
85	2787	A2	124	79	B4
86	2788	A2	125	80	B4
87	2789	A2	126	81	B4
88	2790	A2	127	82	B4
89	2791	A2	128	83	B4
90	2792	A2	129	84	B4
91	2793	A2	130	85	B4
92	2794	A2	131	86	B4
93	2795	A2	132	87	B4
94	2796	A2	133	88	B4
95	2797	A2	134	89	B4
96	2798	A2	135	90	B4
97	2799	A2	136	91	B4
98	2800	A2	137	92	B4
99	2801	A2	138	93	B4
100	2802	A2	139	94	B4
101	2803	A2	140	95	B4
102	2804	A2	141	96	B4
103	2805	A2	142	97	B4
104	2806	A2	143	98	B4
105	2807	A2	144	99	B4
106	2808	A2	145	100	B4
107	2809	A2	146	101	B4
108	2810	A2	147	102	B4
109	2811	A2	148	103	B4
110	2812	A2	149	104	B4
111	2813	A2	150	105	B4
112	2814	A2	151	106	B4
113	2815	A2	152	107	B4
114	2816	A2	153	108	B4
115	2817	A2	154	109	B4
116	2818	A2	155	110	B4
117	2819	A2	156	111	B4
118	2820	A2	157	112	B4
119	2821	A2	158	113	B4
120	2822	A2	159	114	B4
121	2823	A2	160	115	B4
122	2824	A2	161	116	B4
123	2825	A2	162	117	B4
124	2826	A2	163	118	B4
125	2827	A2	164	119	B4
126	2828	A2	165	120	B4
127	2829	A2	166	121	B4
128	2830	A2	167	122	B4
129	2831	A2	168	123	B4
130	2832	A2	169	124	B4
131	2833	A2	170	125	B4
132	2834	A2	171	126	B4
133	2835	A2	172	127	B4
134	2836	A2	173	128	B4
135	2837	A2	174	129	B4
136	2838	A2	175	130	B4
137	2839	A2	176	131	B4
138	2840	A2	177	132	B4
139	2841	A2	178	133	B4
140	2842	A2	179	134	B4
141	2843	A2	180	135	B4
142	2844	A2	181	136	B4
143	2845	A2	182	137	B4
144	2846	A2	183	138	B4
145	2847	A2	184	139	B4
146	2848	A2	185	140	B4
147	2849	A2	186	141	B4
148	2850	A2	187	142	B4
149	2851	A2	188	143	B4
150	2852	A2	189	144	B4
151	2853	A2	190	145	B4
152	2854	A2	191	146	B4
153	2855	A2	192	147	B4
154	2856	A2	193	148	B4
155	2857	A2	194	149	B4
156	2858	A2	195	150	B4
157	2859	A2	196	151	B4
158	2860	A2	197	152	B4
159	2861	A2	198	153	B4
160	2862	A2	199	154	B4
161	2863	A2	200	155	B4
162	2864	A2	201	156	B4
163	2865	A2	202	157	B4
164	2866	A2	203	158	B4
165	2867	A2	204	159	B4
166	2868	A2	205	160	B4
167	2869	A2	206	161	B4
168	2870	A2	207	162	B4
169	2871	A2	208	163	B4
170	2872	A2	209	164	B4
171	2873	A2	210	165	B4
172	2874	A2	211	166	B4
173	2875	A2	212	167	B4
174	2876	A2	213	168	B4
175	2877	A2	214	169	B4
176	2878	A2	215	170	B4
177	2879	A2	216	171	B4
178	2880	A2	217	172	B4
179	2881	A2	218	173	B4
180	2882	A2	219	174	B4
181	2883	A2	220	175	B4
182	2884	A2	221	176	B4
183	2885	A2	222	177	B4
184	2886	A2	223	178	B4
185	2887	A2	224	179	B4
186	2888	A2	225	180	B4
187	2889	A2	226	181	B4
188	2890	A2	227	182	B4
189	2891	A2	228	183	B4
190	2892	A2	229	184	B4
191	2893	A2	230	185	B4
192	2894	A2	231	186	B4
193	2895	A2	232	187	B4
194	2896	A2	233	188	B4
195	2897	A2	234	189	B4
196	2898	A2	235	190	B4
197	2899	A2	236	191	B4
198	2900	A2	237	192	B4
199	2901	A2	238	193	B4
200	2902	A2	239	194	B4
201	2903	A2	240	195	B4
202	2904	A2	241	196	B4
203	2905	A2	242	197	B4
204	2906	A2	243	198	B4
205	2907	A2	244	199	B4
206	2908	A2	245	200	B4
207	2909	A2	246	201	B4
208	2910	A2	247	202	B4
209	2911	A2	248	203	B4
210	2912	A2	249	204	B4
211	2913	A2	250	205	B4
212	2914	A2	251	206	B4
213	2915	A2	252	207	B4
214	2916	A2	253	208	B4
215	2917	A2	254	209	B4
216	2918	A2	255	210	B4
217	2919	A2	256	211	B4
218	2920	A2	257	212	B4
219	2921	A2	258	213	B4
220	2922	A2	259	214	B4
221	2923	A2	260	215	B4
222	2924	A2	261	216	B4
223	2925	A2	262	217	B4
224	2926	A2	263	218	B4
225	2927	A2	264	219	B4
226	2928	A2	265	220	B4
227	2929	A2	266	221	B4
228	2930	A2	267	222	B4
229	2931	A2	268	223	B4
230	2932	A2	269	224	B4
231	2933	A2	270	225	B4
232	2934	A2	271	226	B4
233	2935	A2	272	227	B4
234	2936	A2	273	228	B4
235	2937	A2	274	229	B4
236	2938	A2	275	230	B4
237	2939	A2	276	231	B4
238	2940	A2	277	232	B4
239	2941	A2	278	233	B4
240	2942	A2	279	234	B4
241	2943	A2	280	235	B4
242	2944	A2	281	236	B4
243	2945	A2	282	237	B4
244	2946	A2	283	238	B4
245	2947	A2	284	239	B4
246	2948	A2	285	240	B4
247	2949	A2	286	241	B4
248	2950	A2	287	242	B4
249	2951	A2	288	243	B4
250	2952	A2	289	244	B4
251	2953	A2	290	245	B4
252	2954	A2	291	246	B4
253	2955	A2	292	247	B4
254	2956	A2	293	248	B4
255	2957	A2	294	249	B4
256	2958	A2	295	250	B4
257	2959	A2	296	251	B4
258	2960	A2	297	252	B4
259	2961	A2	298	253	B4
260	2962	A2	299	254	B4
261	2963	A2	300	255	B4
262	2964	A2	301	256	B4
263	2965	A2	302	257	B4
264	2966	A2	303	258	B4
265	2967	A2	304	259	B4
266	2968	A2	305	260	B4
267	2969	A2	306	261	B4

CDR MAIN BOARD - BOTTOM VIEW : AUDIO TESTPOINTS

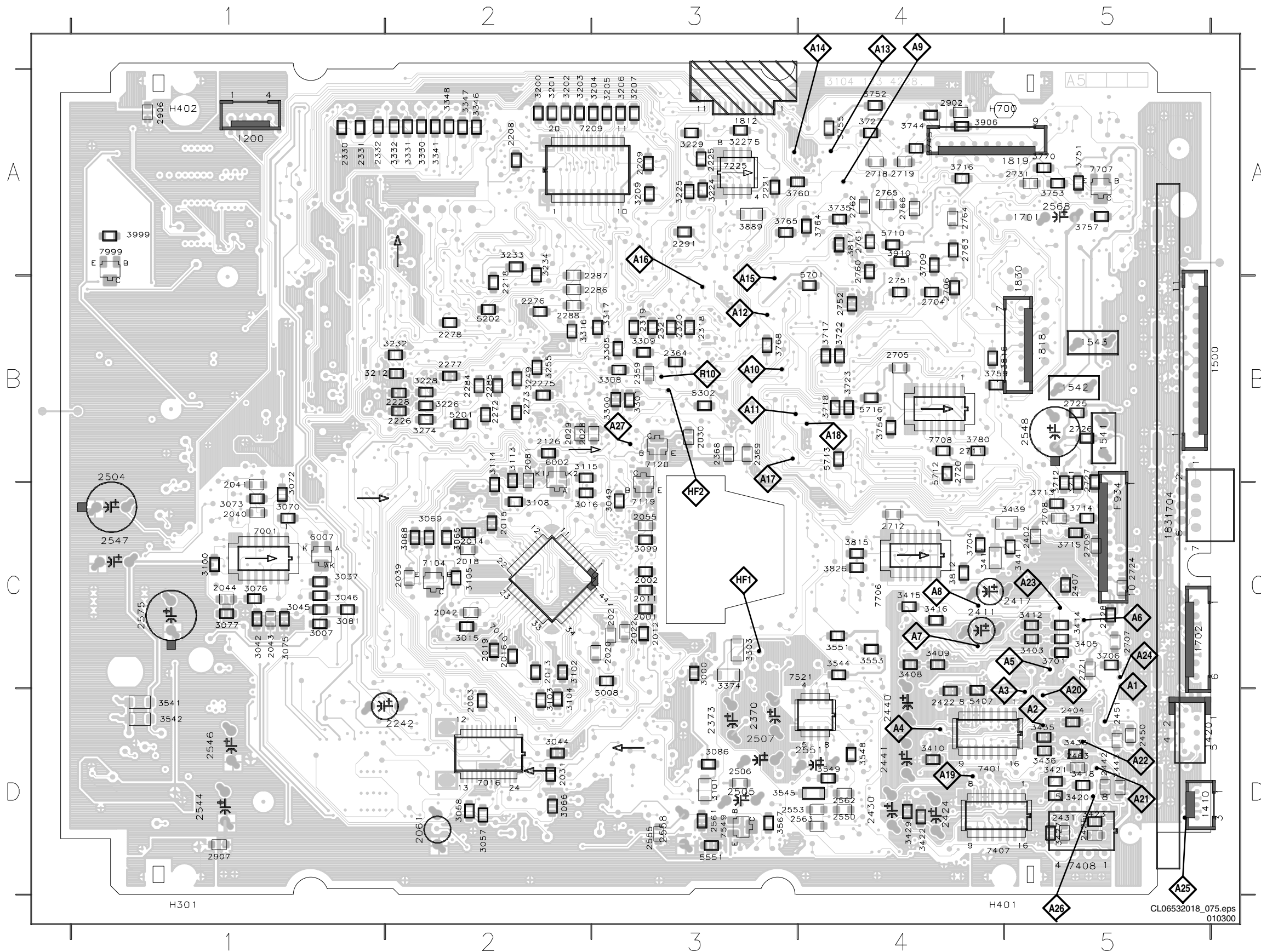

181	A	2720	B4
182	A	2721	B4
183	A	2722	B4
184	A	2723	B4
185	A	2724	B4
186	A	2725	B4
187	A	2726	B4
188	A	2727	B4
189	A	2728	B4
190	A	2729	B4
191	A	2730	B4
192	A	2731	B4
193	A	2732	B4
194	A	2733	B4
195	A	2734	B4
196	A	2735	B4
197	A	2736	B4
198	A	2737	B4
199	A	2738	B4
200	A	2739	B4
201	A	2740	B4
202	A	2741	B4
203	A	2742	B4
204	A	2743	B4
205	A	2744	B4
206	A	2745	B4
207	A	2746	B4
208	A	2747	B4
209	A	2748	B4
210	A	2749	B4
211	A	2750	B4
212	A	2751	B4
213	A	2752	B4
214	A	2753	B4
215	A	2754	B4
216	A	2755	B4
217	A	2756	B4
218	A	2757	B4
219	A	2758	B4
220	A	2759	B4
221	A	2760	B4
222	A	2761	B4
223	A	2762	B4
224	A	2763	B4
225	A	2764	B4
226	A	2765	B4
227	A	2766	B4
228	A	2767	B4
229	A	2768	B4
230	A	2769	B4
231	A	2770	B4
232	A	2771	B4
233	A	2772	B4
234	A	2773	B4
235	A	2774	B4
236	A	2775	B4
237	A	2776	B4
238	A	2777	B4
239	A	2778	B4
240	A	2779	B4
241	A	2780	B4
242	A	2781	B4
243	A	2782	B4
244	A	2783	B4
245	A	2784	B4
246	A	2785	B4
247	A	2786	B4
248	A	2787	B4
249	A	2788	B4
250	A	2789	B4
251	A	2790	B4
252	A	2791	B4
253	A	2792	B4
254	A	2793	B4
255	A	2794	B4
256	A	2795	B4
257	A	2796	B4
258	A	2797	B4
259	A	2798	B4
260	A	2799	B4
261	A	2800	B4
262	A	2801	B4
263	A	2802	B4
264	A	2803	B4
265	A	2804	B4
266	A	2805	B4
267	A	2806	B4
268	A	2807	B4
269	A	2808	B4
270	A	2809	B4
271	A	2810	B4
272	A	2811	B4
273	A	2812	B4
274	A	2813	B4
275	A	2814	B4
276	A	2815	B4
277	A	2816	B4
278	A	2817	B4
279	A	2818	B4
280	A	2819	B4
281	A	2820	B4
282	A	2821	B4
283	A	2822	B4
284	A	2823	B4
285	A	2824	B4
286	A	2825	B4
287	A	2826	B4
288	A	2827	B4
289	A	2828	B4
290	A	2829	B4
291	A	2830	B4
292	A	2831	B4
293	A	2832	B4
294	A	2833	B4
295	A	2834	B4
296	A	2835	B4
297	A	2836	B4
298	A	2837	B4
299	A	2838	B4
300	A	2839	B4
301	A	2840	B4
302	A	2841	B4
303	A	2842	B4
304	A	2843	B4
305	A	2844	B4
306	A	2845	B4
307	A	2846	B4
308	A	2847	B4
309	A	2848	B4
310	A	2849	B4
311	A	2850	B4
312	A	2851	B4
313	A	2852	B4
314	A	2853	B4
315	A	2854	B4
316	A	2855	B4
317	A	2856	B4
318	A	2857	B4
319	A	2858	B4
320	A	2859	B4
321	A	2860	B4
322	A	2861	B4
323	A	2862	B4
324	A	2863	B4
325	A	2864	B4
326	A	2865	B4
327	A	2866	B4
328	A	2867	B4
329	A	2868	B4
330	A	2869	B4
331	A	2870	B4
332	A	2871	B4
333	A	2872	B4
334	A	2873	B4
335	A	2874	B4
336	A	2875	B4
337	A	2876	B4
338	A	2877	B4
339	A	2878	B4
340	A	2879	B4
341	A	2880	B4
342	A	2881	B4
343	A	2882	B4
344	A	2883	B4
345	A	2884	B4
346	A	2885	B4
347	A	2886	B4
348	A	2887	B4
349	A	2888	B4
350	A	2889	B4
351	A	2890	B4
352	A	2891	B4
353	A	2892	B4
354	A	2893	B4
355	A	2894	B4
356	A	2895	B4
357	A	2896	B4
358	A	2897	B4
359	A	2898	B4
360	A	2899	B4
361	A	2900	B4
362	A	2901	B4
363	A	2902	B4
364	A	2903	B4
365	A	2904	B4
366	A	2905	B4
367	A	2906	B4
368	A	2907	B4
369	A	2908	B4
370	A	2909	B4
371	A	2910	B4
372	A	2911	B4
373	A	2912	B4
374	A	2913	B4
375	A	2914	B4
376	A	2915	B4
377	A	2916	B4
378	A	2917	B4
379	A	2918	B4
380	A	2919	B4
381	A	2920	B4
382	A	2921	B4
383	A	2922	B4
384	A	2923	B4
385	A	2924	B4
386	A	2925	B4
387	A	2926	B4
388	A	2927	B4
389	A	2928	B4
390	A	2929	B4
391	A	2930	B4
392	A	2931	B4
393	A	2932	B4
394	A	2933	B4
395	A	2934	B4
396	A	2935	B4
397	A	2936	B4
398	A	2937	B4
399	A	2938	B4
400	A	2939	B4
401	A	2940	B4
402	A	2941	B4
403	A	2942	B4
404	A	2943	B4
405	A	2944	B4
406	A	2945	B4
407	A	2946	B4
408	A	2947	B4
409	A	2948	B4
410	A	2949	B4
411	A	2950	B4
412	A	2951	B4
413	A	2952	B4
414	A	2953	B4
415	A	2954	B4
416	A	2955	B4
417	A	2956	B4
418	A	2957	B4
419	A	2958	B4
420	A	2959	B4
421	A	2960	B4
422	A	2961	B4
423	A	2962	B4
424	A	2963	B4
425	A	2964	B4
426	A	2965	B4
427	A	2966	B4
428	A	2967	B4
429	A	2968	B4
430	A	2969	B4
431	A	2970	B4
432	A	2971	B4
433	A	2972	B4
434	A	2973	B4
435	A	2974	B4
436	A	2975	B4
437	A	2976	B4
438	A	2977	B4
439	A	2978	B4
440	A	2979	B4
441	A	2980	B4
442	A	2981	B4
443	A	2982	B4
444	A	2983	B4
445	A	2984	B4
446	A	2985	B4
447	A	2986	B4
448	A	2987	B4
449	A	2988	B4
450	A	2989	B4
451	A	2990	B4
452	A	2991	B4
453	A	2992	B4
454	A	2993	B4
455	A	2994	B4
456	A	2995	B4
457	A	2996	B4
458	A	2997	B4
459	A	2998	B4
460	A	2999	B4
461	A	3000	B4
462	A	3001	B4
463	A	3002	B4
464	A	3003	B4
465	A	3004	B4
466	A	3005	B4
467	A	3006	B4
468	A	3007	B4
469	A	3008	B4
470	A	3009	B4
471	A	3010	B4
472	A	3011	B4
473	A	3012	B4
474	A	3013	B4
475	A	3014	B4
476	A	3015	B4
477	A	3016	B4
478	A	3017	B4
479	A	3018	B4
480	A	3019	B4
481	A	3020	B4
482	A	3021	B4
483	A	3022	B4
484	A	3023	B4
485	A	3024	B4
486	A	3025	B4
487	A	3026	B4
488	A	3027	B4
489	A	3028	B4
490	A	3029	B4
491	A	3030	B4
492	A	3031	B4
493	A	3032	B4
494	A	3033	B4
495	A	3034	B4
496	A	3035	B4
497	A	3036	B4
498	A	3037	B4
499	A	3038	B4
500	A	3039	B4
501	A	3040	B4
502	A	3041	B4
503	A	3042	B4
504	A	3043	B4
505	A	3044	B4
506	A	3045	B4
507	A	3046	B4
508	A	3047	B4
509	A	3048	B4
510	A	3049	B4
511	A	3050	B4
512	A	3051	B4
513	A	3052	B4
514	A	3053	B4
515	A	3054	B4
516	A	3055	B4
517	A	3056	B4
518	A	3057	B4
519	A	3058	B4
520	A	3059	B4
521	A	3060	B4
522	A	3061	B4
523	A	3062	B4
524	A	3063	B4
525	A	3064	B4
526	A	3065	B4
527	A	3066	B4
528	A	3067	B4
529	A	3068	B4
530	A	3069	B4
531	A	3070	B4
532	A	3071	B4
533	A	3072	B4
534	A	3073	B4
535	A	3074	B4
536	A	3075	B4
537	A	3076	B4
538	A	3077	B4
539	A	3078	B4
540	A	3079	B4
541	A	3080	B4
542	A	3081	B4
543	A	3082	B4
544	A	3083	B4
545	A	3084	B4
546	A	3085	B4
547	A	3086	B4
548	A	3087	B4
549	A	3088	B4
550	A	3089	B4
551	A	3090	B4
552	A	3091	B4
553	A	3092	B4
554	A	3093	B4
555	A	3094	B4
556			

CDR MAINBOARD: SURVEY OF TESTPOINTS

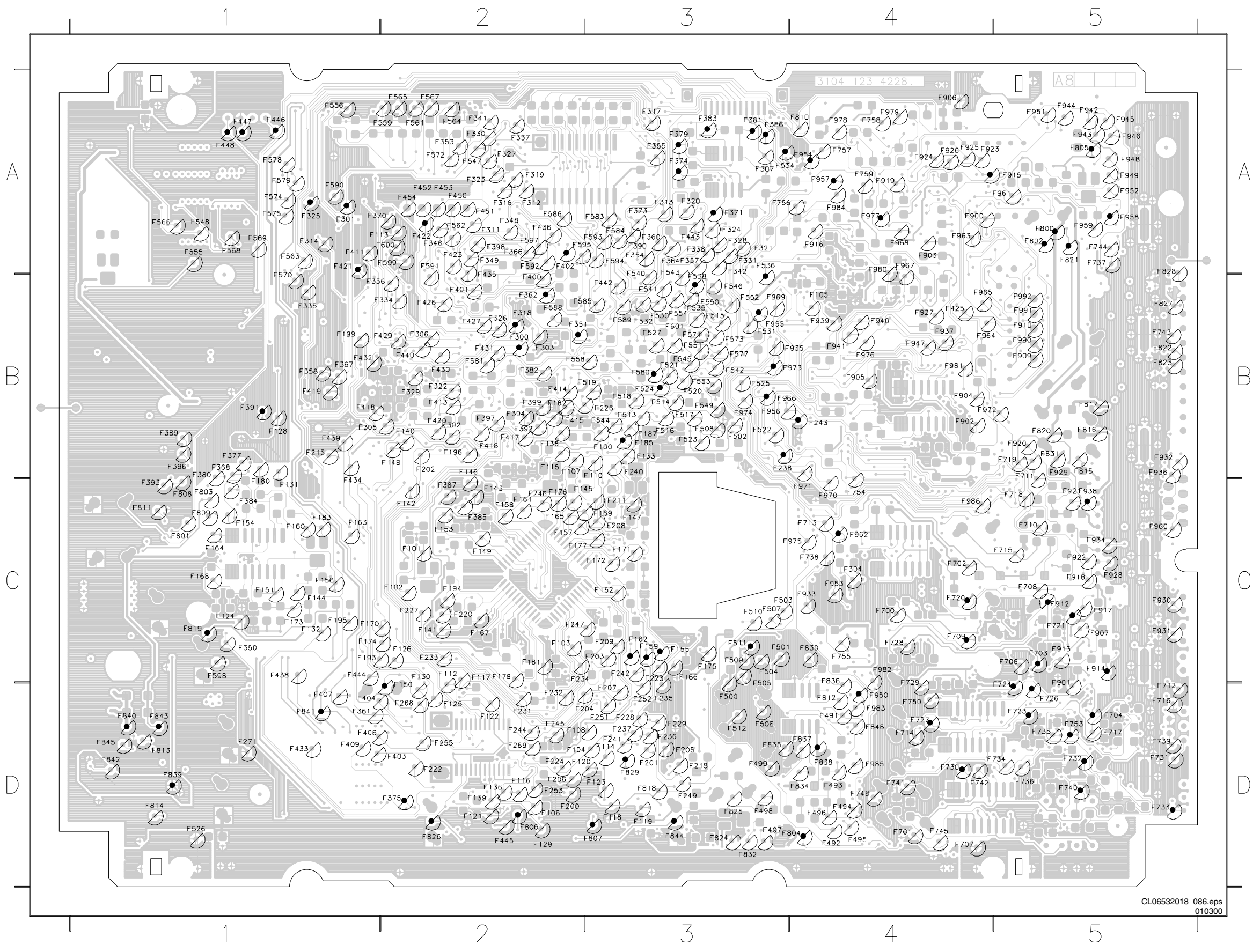

CL06532018_086.eps
010300

1705
1704
1703
1702
1701
1699
1698
1697
1696
1695
1694
1693
1692
1691
1690
1689
1688
1687
1686
1685
1684
1683
1682
1681
1680
1679
1678
1677
1676
1675
1674
1673
1672
1671
1670
1669
1668
1667
1666
1665
1664
1663
1662
1661
1660
1659
1658
1657
1656
1655
1654
1653
1652
1651
1650
1649
1648
1647
1646
1645
1644
1643
1642
1641
1640
1639
1638
1637
1636
1635
1634
1633
1632
1631
1630
1629
1628
1627
1626
1625
1624
1623
1622
1621
1620
1619
1618
1617
1616
1615
1614
1613
1612
1611
1610
1609
1608
1607
1606
1605
1604
1603
1602
1601
1600
1599
1598
1597
1596
1595
1594
1593
1592
1591
1590
1589
1588
1587
1586
1585
1584
1583
1582
1581
1580
1579
1578
1577
1576
1575
1574
1573
1572
1571
1570
1569
1568
1567
1566
1565
1564
1563
1562
1561
1560
1559
1558
1557
1556
1555
1554
1553
1552
1551
1550
1549
1548
1547
1546
1545
1544
1543
1542
1541
1540
1539
1538
1537
1536
1535
1534
1533
1532
1531
1530
1529
1528
1527
1526
1525
1524
1523
1522
1521
1520
1519
1518
1517
1516
1515
1514
1513
1512
1511
1510
1509
1508
1507
1506
1505
1504
1503
1502
1501
1500
1499
1498
1497
1496
1495
1494
1493
1492
1491
1490
1489
1488
1487
1486
1485
1484
1483
1482
1481
1480
1479
1478
1477
1476
1475
1474
1473
1472
1471
1470
1469
1468
1467
1466
1465
1464
1463
1462
1461
1460
1459
1458
1457
1456
1455
1454
1453
1452
1451
1450
1449
1448
1447
1446
1445
1444
1443
1442
1441
1440
1439
1438
1437
1436
1435
1434
1433
1432
1431
1430
1429
1428
1427
1426
1425
1424
1423
1422
1421
1420
1419
1418
1417
1416
1415
1414
1413
1412
1411
1410
1409
1408
1407
1406
1405
1404
1403
1402
1401
1400
1399
1398
1397
1396
1395
1394
1393
1392
1391
1390
1389
1388
1387
1386
1385
1384
1383
1382
1381
1380
1379
1378
1377
1376
1375
1374
1373
1372
1371
1370
1369
1368
1367
1366
1365
1364
1363
1362
1361
1360
1359
1358
1357
1356
1355
1354
1353
1352
1351
1350
1349
1348
1347
1346
1345
1344
1343
1342
1341
1340
1339
1338
1337
1336
1335
1334
1333
1332
1331
1330
1329
1328
1327
1326
1325
1324
1323
1322
1321
1320
1319
1318
1317
1316
1315
1314
1313
1312
1311
1310
1309
1308
1307
1306
1305
1304
1303
1302
1301
1300
1299
1298
1297
1296
1295
1294
1293
1292
1291
1290
1289
1288
1287
1286
1285
1284
1283
1282
1281
1280
1279
1278
1277
1276
1275
1274
1273
1272
1271
1270
1269
1268
1267
1266
1265
1264
1263
1262
1261
1260
1259
1258
1257
1256
1255
1254
1253
1252
1251
1250
1249
1248
1247
1246
1245
1244
1243
1242
1241
1240
1239
1238
1237
1236
1235
1234
1233
1232
1231
1230
1229
1228
1227
1226
1225
1224
1223
1222
1221
1220
1219
1218
1217
1216
1215
1214
1213
1212
1211
1210
1209
1208
1207
1206
1205
1204
1203
1202
1201
1200
1199
1198
1197
1196
1195
1194
1193
1192
1191
1190
1189
1188
1187
1186
1185
1184
1183
1182
1181
1180
1179
1178
1177
1176
1175
1174
1173
1172
1171
1170
1169
1168
1167
1166
1165
1164
1163
1162
1161
1160
1159
1158
1157
1156
1155
1154
1153
1152
1151
1150
1149
1148
1147
1146
1145
1144
1143
1142
1141
1140
1139
1138
1137
1136
1135
1134
1133
1132
1131
1130
1129
1128
1127
1126
1125
1124
1123
1122
1121
1120
1119
1118
1117
1116
1115
1114
1113
1112
1111
1110
1109
1108
1107
1106
1105
1104
1103
1102
1101
1100
1099
1098
1097
1096
1095
1094
1093
1092
1091
1090
1089
1088
1087
1086
1085
1084
1083
1082
1081
1080
1079
1078
1077
1076
1075
1074
1073
1072
1071
1070
1069
1068
1067
1066
1065
1064
1063
1062
1061
1060
1059
1058
1057
1056
1055
1054
1053
1052
1051
1050
1049
1048
1047
1046
1045
1044
1043
1042
1041
1040
1039
1038
1037
1036
1035
1034
1033
1032
1031
1030
1029
1028
1027
1026
1025
1024
1023
1022
1021
1020
1019
1018
1017
1016
1015
1014
1013
1012
1011
1010
1009
1008
1007
1006
1005
1004
1003
1002
1001
1000
999
998
997
996
995
994
993
992
991
990
989
988
987
986
985
984
983
982
981
980
979
978
977
976
975
974
973
972
971
970
969
968
967
966
965
964
963
962
961
960
959
958
957
956
955
954
953
952
951
950
949
948
947
946
945
944
943
942
941
940
939
938
937
936
935
934
933
932
931
930
929
928
927
926
925
924
923
922
921
920
919
918
917
916
915
914
913
912
911
910
909
908
907
906
905
904
903
902
901
900
899
898
897
896
895
894
893
892
891
890
889
888
887
886
885
884
883
882
881
880
879
878
877
876
875
874
873
872
871
870
869
868
867
866
865
864
863
862
861
860
859
858
857
856
855
854
853
852
851
850
849
848
847
846
845
844
843
842
841
840
839
838
837
836
835
834
833
832
831
830
829
828
827
826
825
824
823
822
821
820
819
818
817
816
815
814
813
812
811
810
809
808
807
806
805
804
803
802
801
800
799
798
797
796
795
794
793
792
791
790
789
788
787
786
785
784
783
782
781
780
779
778
777
776
775
774
773
772
771
770
769
768
767
766
765
764
763
762
761
760
759
758
757
756
755
754
753
752
751
750
749
748
747
746
745
744
743
742
741
740
739
738
737
736
735
734
733
732
731
730
729
728
727
726
725
724
723
722
721
720
719
718
717
716
715
714
713
712
711
710
709
708
707
706
705
704
703
702
701
700
699
698
697
696
695
694
693
692
691
690
689
688
687
686
685
684
683
682
681
680
679
678
677
676
675
674
673
672
671
670
669
668
667
666
665
664
663
662
661
660
659
658
657
656
655
654
653
652
651
650
649
648
647
646
645
644
643
642
641
640
639
638
637
636
635
634
633
632
631
630
629
628
627
626
625
624
623
622
621
620
619
618
617
616
615
614
613
612
611
610
609
608
607
606
605
604
603
602
601
600
599
598
597
596
595
594
593
592
591
590
589
588
587
586
585
584
583
582
581
580
579
578
577
576
575
574
573
572
571
570
569
568
567
566
565
564
563
562
561
560
559
558
557
556
555
554
553
552
551
550
549
548
547
546
545
544
543
542
541
540
539
538
537
536
535
534
533
532
531
530
529
528
527
526
525
524
523
522
521
520
519
518
517
516
515
514
513
512
511
510
509
508
507
506
505
504
503
502
501
500
499
498
497
496
495
494
493
492
491
490
489
488
487
486
485
484
483
482
481
480
479
478
477
476
475
474
473
472
471
470
469
468
467
466
465
464
463
462
461
460
459
458
457
456
455
454
453
452
451
450
449
448
447
446
445
444
443
442
441
440
439
438
437
436
435
434
433
432
431
430
429
428
427
426
425
424
423
422
421
420
419
418
417
416
415
414
413
412
411
410
409
408
407
406
405
404
403
402
401
400
399
398
397
396
395
394
393
392
391
390
389
388
387
386
385
384
383
382
381
380
379
378
377
376
375
374
373
372
371
370
369
368
367
366
365
364
363
362
361
360
359
358
357
356
355
354
353
352
351
350
349
348
347
346
345
344
343
342
341
340
339
338
337
336
335
334
333
332
331
330
329
328
327
326
325
324
323
322
321
320
319
318
317
316
315
314
313
312
311
310
309
308
307
306
305
304
303
302
301
300
299
298
297
296
295
294
293
292
291
290
289
288
287
286
285
284
283
282
281
280
279
278
277
276
275
274
273
272
271
270
269
268
267
266
265
264
263
262
261
260
259
258
257
256
255
254
253
252
251
250
249
248
247
246
245
244
243
242
241
240
239
238
237
236
235
234
233
232
231
230
229
228
227
226
225
224
223
222
221
220
219
218
217
216
215
214
213
212
211
210
209
208
207
206
205
204
203
202
201
200
199
198
197
196
195
194
193
192
191
190
189
188
187
186
185
184
183
182
181
180
179
178
177
176
175
174
173
172
171
170
169
168
167
166
165
164
163
162
161
160
159
158
157
156
155
154
153
152
151
150
149
148
147
146
145
144
143
142
141
140
139
138
137
136
135
134
133
132
131
130
129
128
127
126
125
124
123
122
121
120
119
118
117
116
115
114
113
112
111
110
109
108
107
106
105
104
103
102
101
100
99
98
97
96
95
94
93
92
91
90
89
88
87
86
85
84
83
82
81
80
79
78
77
76
75
74
73
72
71
70
69
68
67
66
65
64
63
62
61
60
59
58
57
56
55
54
53
52
51
50
49
48
47
46
45
44
43
42
41
40
39
38
37
36
35
34
33
32
31
30
29
28
27
26
25
24
23
22
21
20
19
18
17
16
15
14
13
12
11
10
9
8
7
6
5
4
3
2
1