

BEDIENINGSORGANEN

1. Klank
2. Batterijschakelaar
3. Verlichtingsschakelaar
4. Geluidssterkte (R36)
5. Afstemming
6. FM-schakelaar
7. LG-schakelaar
8. MG-schakelaar
9. KG-schakelaar

SPECIFICATIE

Lange golf	1145 - 2000 m (262 - 150 kHz)
Middengolf	185,2 - 580,3 m (1622 - 517 kHz)
Kortegolf	25 - 50 m (12 - 6 MHz)
FM	2,88 - 3,43 m (104 - 87,5 MHz)
Luidspreker	AD 2309 SY, 8 ohm, 2 W
Voedingsspanning	6 V (4 x 1,5 V)
Verbruik	15-20 mA (AM) 19-24 mA (FM)
Uitgangsvermogen	380 mW
Afmetingen	13 x 23 x 4 cm

AANSLUITINGEN

Oortelefoon

PRINCIPESHEMA pagina 109

OVERZICHT HALFGELEIDERS

TS 1	AF 124	HF-versterker FM
TS 2	AF 125	Oscillator en menggedeelte FM
TS 3	AF 125	Oscillator en menggedeelte AM, tevens MF-versterker FM
TS 4	AF 126	MF-versterker AM en FM
TS 5	AF 126	MF-versterker AM en FM
1S 6	AC 125	LF-voorversterker
1S 7	408 09	LF-voorversterker
TS 8	408 09	Eindversterker
TS 9	408 09	Eindversterker
TS 10	408 09	Eindversterker
GR 1	AA 119	Eegrenzer
GR 2	AA 119	Regeldiode AVR
GR 3	AA 119	Detector AM
GR 4	AA 119	Detector FM
GR 5	AA 119	Detector FM
GR 6	BA 114	Stabiliseerdiodi

CODENUMMERS

Front (01R)	4822 108 00645
Front (03R)	4822 116 00843
Front (52R)	4822 116 00844
Achterwand	4822 108 00644
Batterijhouder	4822 108 00646
Knop, geluidssterkteregelaar	4822 107 00604
Knop, afstemming	4822 162 01083
Telescoopantenne	4822 108 00647
Batterij/klank schakelaar	4822 108 00648
Beugel met knop geluidssterkte-regelaar/verlichting	4822 116 00716
Bus voor oortelefoon	4822 211 00965
Contactstrip voor batterijhouder	4822 108 00649
Steker met draad voor tegencapaciteit	A3 157 72
Trommel, aandrijving	P5 420 65/HA
Schaalachtergrond	4822 108 00659
Druktoetsenheid, golfgebieden	A3 099 41
Beugel met druktoetsen	4822 097 0073
Indicator, batterij/afstemming	4822 108 00651
Ferroceptor MG/LG	4822 117 00236
Variabele condensator	4822 059 00345
Geluidssterkteregelaar R36	B1 530 82
Verlichtingslampje L1	4822 108 00498

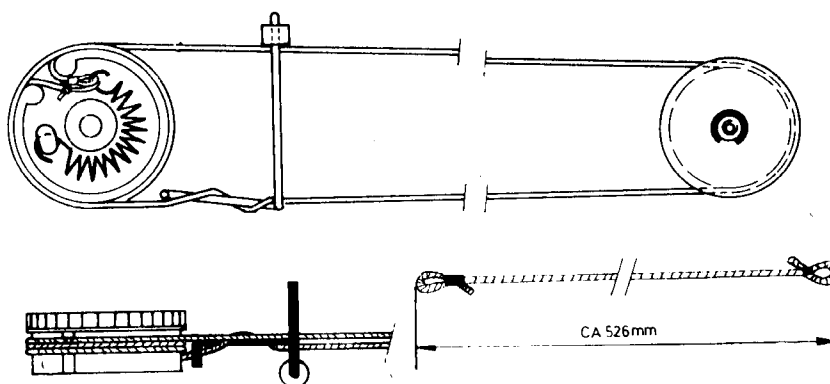

S	13.	51.	16.	46.	57.	58.	59.	57.	56.61.67.																																																	
C	11.	9.	14.	15.	16.	17.	18.	19.	20.	21.	22.	23.	24.	25.	26.	34.	72.	35.	29.	40.	38.	39.	33.	30.	42.	56.	77.	50.	52.	53.	43.	51.	47.	46.	53.	43.	42.	24.	54.	44.	25.	47.	48.	53.	43.	42.	24.	54.	51.	52.	40.	39.	41.	50.	55.	49.	37.	38.
R	2.	5.	3.	6.	8.	10.	7.	11.	4.	9.	14.	15.	12.	13.	17.	18.	19.	28.	27.	33.	34.	57.	20.	31.	35.	32.	30.	56.	22.	21.	46.	29.	26.	45.	44.	25.	47.	48.	53.	43.	42.	24.	54.															

TS.6.78.9.10.

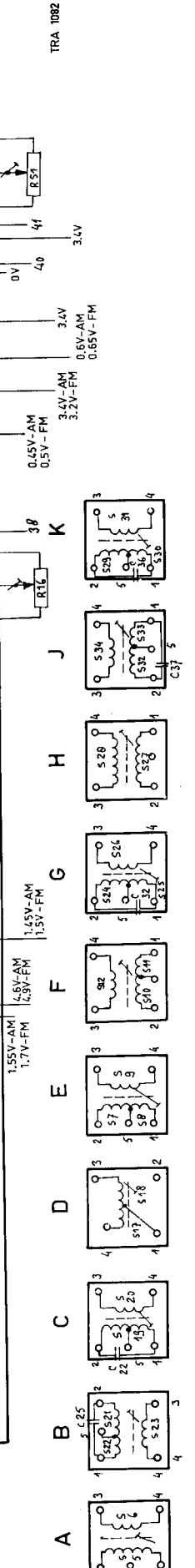
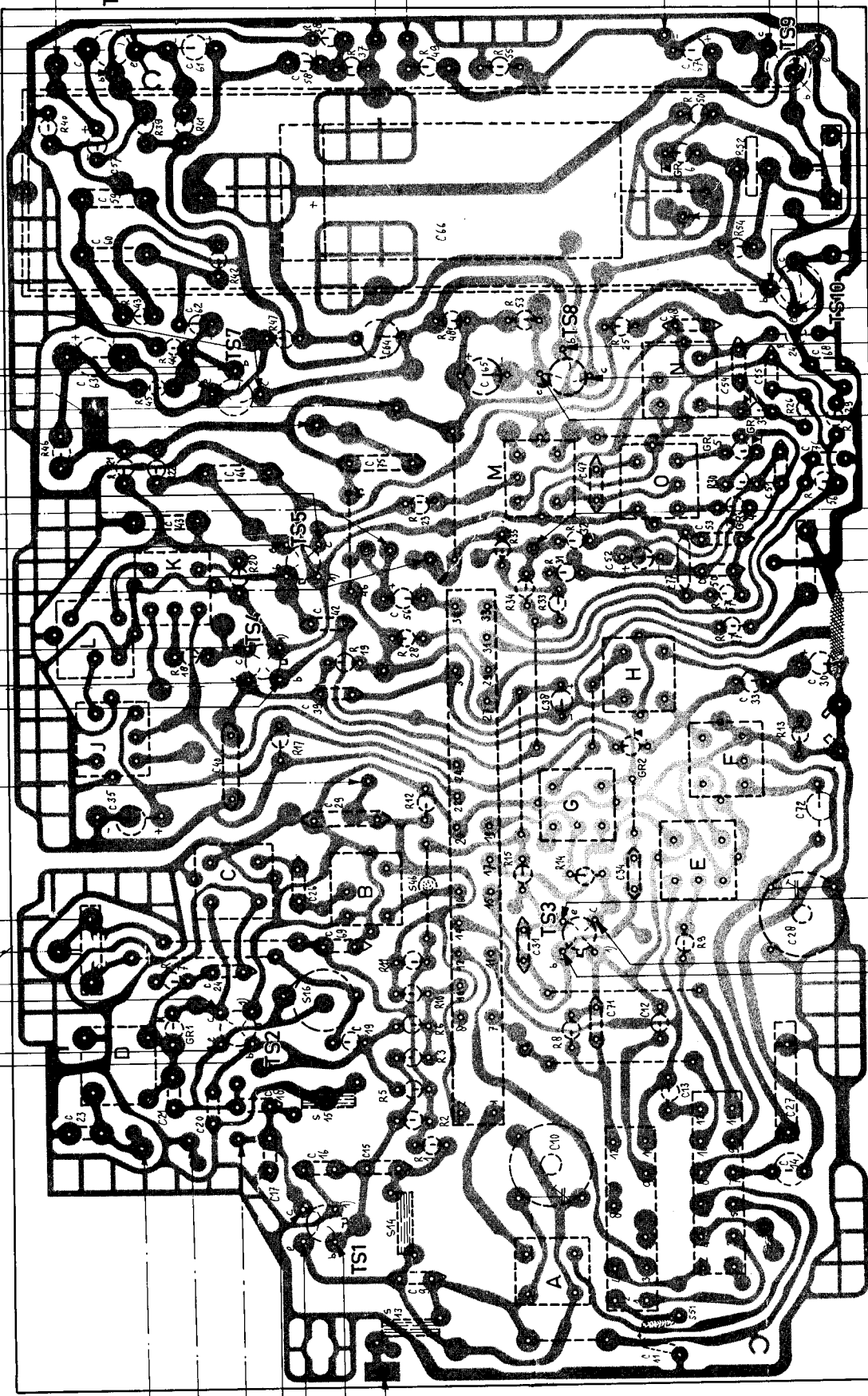
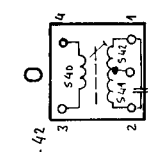
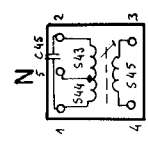
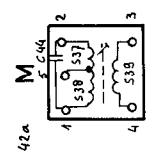
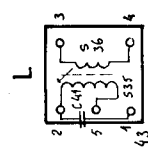
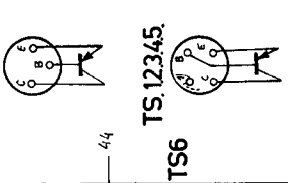

TRA 1082

5.2V-FM

2.6V-FM

0.85V-FM

3.6V

2.2V-FM

2.4V

2.4V-AM

2.25V-FM

2.6V-FM

0.8V-AM

0.7V-FM

0.4V-AM

0.6V-FM

0.15V-AM

0.4V-FM

4V-AM

5V-FM

26.5.2V-AM

25.4.25.47

2.4V-AM

2.25V-FM

2.4V-AM

0.65V-FM

2.8V-AM

2.6V-FM

5V

3.6V

2.2V-FM

2.4V

0.45V-AM

0.5V-FM

3.4V-AM

0.6V-AM

0.65V-FM

3.4V

0V

40

8.5V

3.6V

6V

3.6V

3.6V

SCHEMA L 2 W 54 T

S	51,12	14	1+5, 6	15	16	19,17,18, 20	21,22, 23	24,25	26	7-12	27, 28	29-34	35	36
R	1	2	3	4	5	6	7	8	9	10	11	12,11	13,14	15
C	3	1	10,11	9,15	16	5	6	7	10	12,11	13	28	16	18,19

TS1
AF172

TS2
AF175

TS3
AF175

TS4
AF176

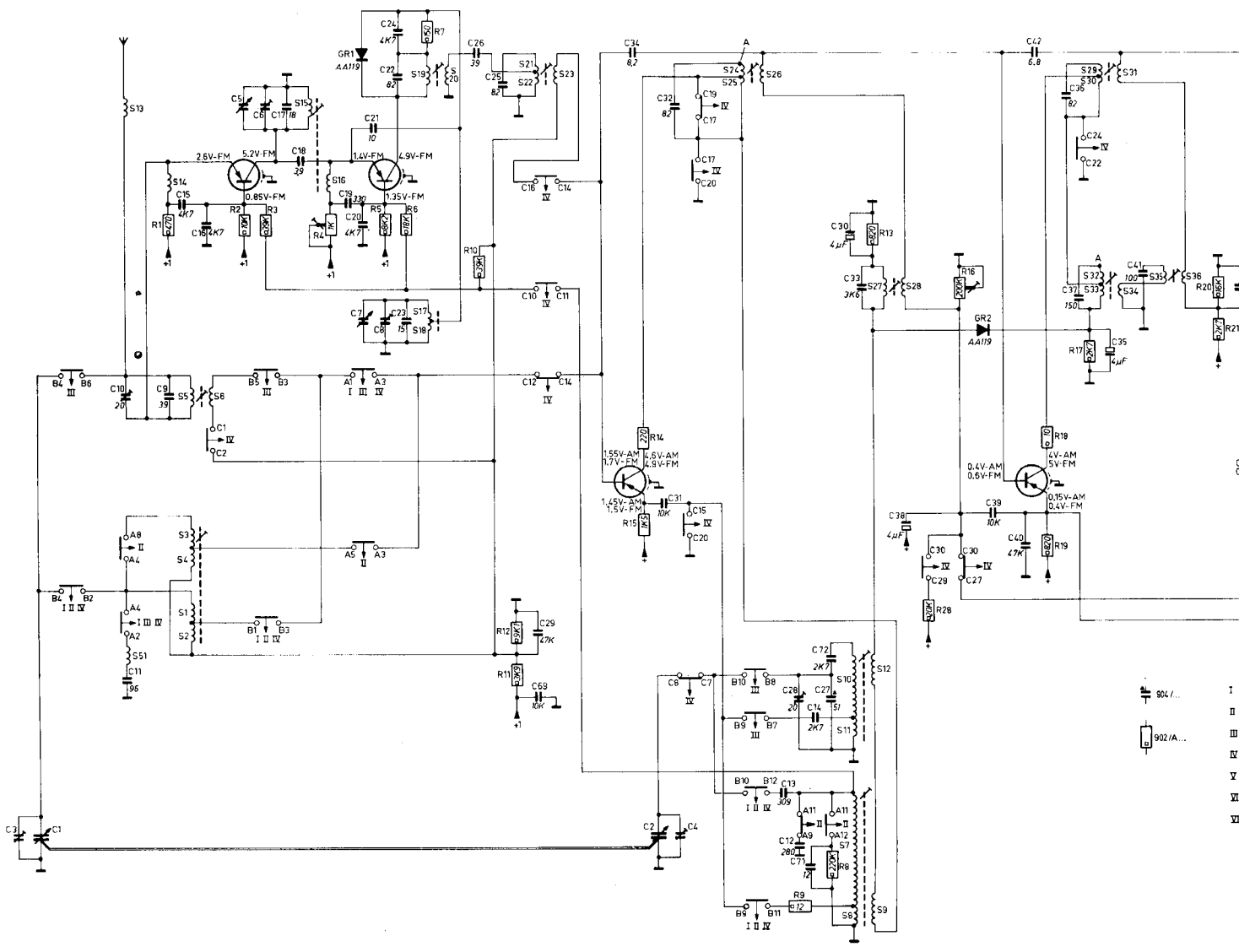

- I - 904 / ...
- II -
- III -
- IV -
- V -
- VI -
- VII -

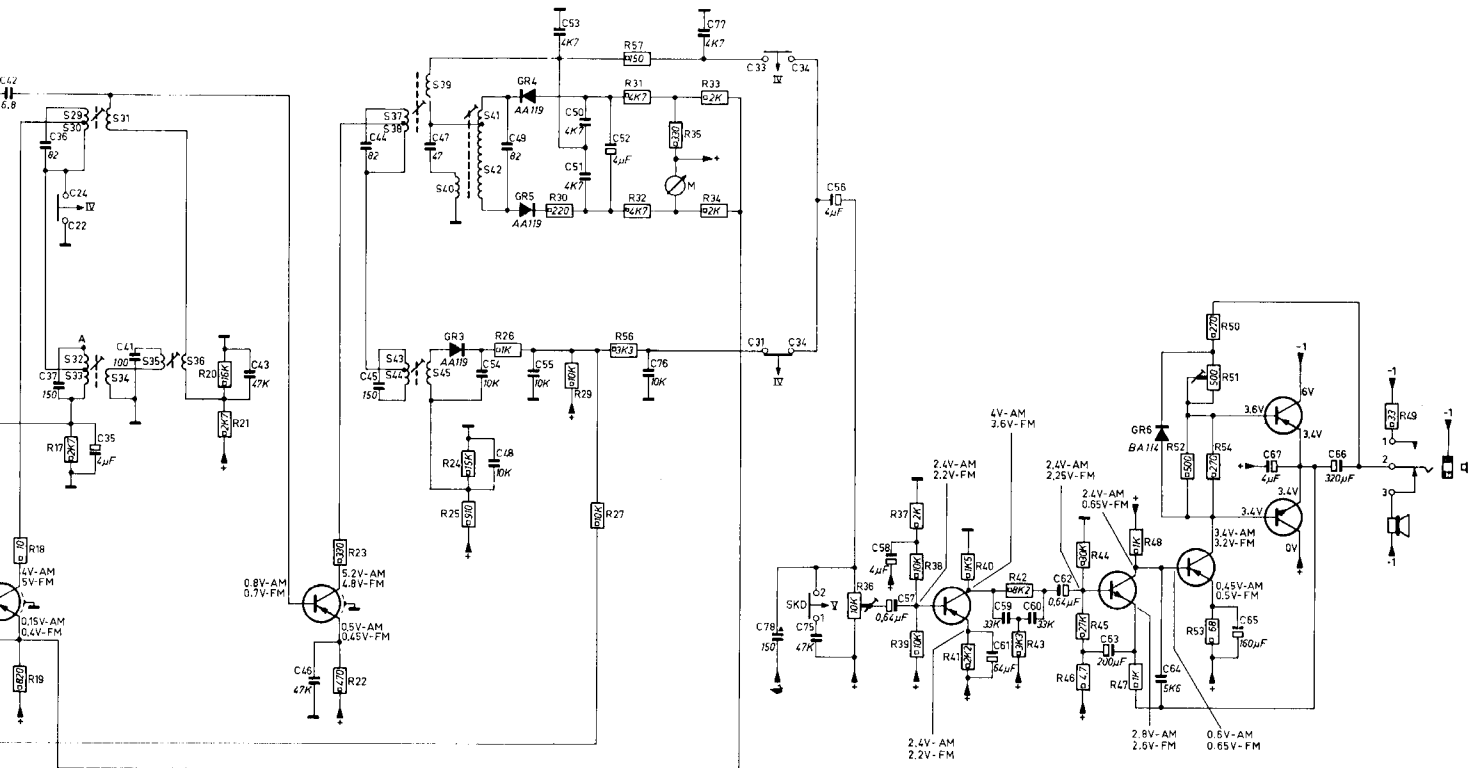

- 904/...
 - 902/A...
- | | | | | |
|---|------------|------------|-----------|-----------|
| I - LW | - LG | - GO | - LW | - OL |
| II - MW | - MG | - PO | - MW | - OM |
| III - SW | - KG | - OC | - KW | - OC |
| IV - FM | - FM | - FM | - UKW | - FM |
| V - LO | | | | |
| VI - BATTERY | - BATTERIJ | - BATTERIE | - BATERIE | - BATERIA |
| VII - DIAL LIGHTING - SCHAALVERLICHTING - ILLUMINATION DE CADRAN - SKALENERLEUCHTUNG - ALUMBRADO DE CUADRANTE | | | | |

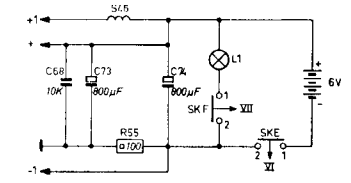

TRA 1084