

**Service Guide**

# Troubleshooting Power Amplifiers

Supplement to Tuning Fork



 **PIONEER®**

# Introduction

In 1877, Edison realized the dream of people to record and reproduce sound by inventing the phonogram. Since then, it has been improved by many inventors to become LP hi-fi audio system. Efforts to reproduce even higher quality sound are still being made.

The Digital Audio Disc (DAD), (Compact Disc (CD)) system has marked the dawn of a new era in the audio world. A few years ago, a digital audio system was demonstrated at the Japan Audio Fair, and impressed the audience with its high quality and wide dynamic range. DAD players are now being introduced in many countries. Reviewing the history of audio equipment makes us believe that DAD will supersede other systems in the future. An audio system is no longer a status symbol of the rich, but is one of the necessities of audiophiles everywhere.

What with the increasing number of audiophiles and the advent of the DAD player require? They will require peripheral equipment such as amplifiers and speaker systems to be improved more and more, thus stimulating the competing analogue systems. To reproduce the low-distortion, low-noise and wide dynamic range-sounds recorded with DAD, the performance of amplifier and speaker systems must be very high. Pioneer's Non-Switching Amplifier (NSA) and Dynamic Power Supply Amplifier (DPSA) have responded to this requirement. After various studies, the NSA was employed in Pioneer systems. The dynamic power supply system has added more sophisticated high-powered and high-efficiency circuits to NSA.

The problems voiced by technicians in the field are as follows:

- a) It is difficult to understand the principle of the circuits.
- b) It takes a long time to troubleshoot the circuits.
- c) Power transistors and other components are damaged again and again when the power switch is turned on after having replaced faulty components.
- d) Replacing more components than those really required without finding real cause is expensive.
- e) As a result, repair charges rise, making customers upset.

Nowadays, competition is keen not only in commodity price but also in post-sales service. To have the troubleshooting knowhow is the only way to solve the problem.

The reasons why NSAs are hard to repair are that all stages are directly coupled DC-wise, they have special bias circuits, and some models have a DC negative feedback (NFB) loop. They have many components and thus are very complicated to troubleshoot.

In reality, new amplifiers have no basic difference from the conventional ones. If you have the basic knowledge of the principle of the conventional amplifiers, understanding the operation of NSA, DPSA and their troubleshooting are not so difficult.

In this edition, we will discuss typical amplifiers one by one from the simplest Single-Ended Push-Pull type to the sophisticated, NSA DPSA and their troubleshooting. If you know the conventional amplifiers, start from NSA.

Among many amplifiers, A-7 and A-80 will be referred to for discussing NSA and DPSA respectively. The basic principle and troubleshooting are the same among the models of the same series such as A-5, A-6, A-7, A-8, A-9, SX-7, SX-8 and SX-9, and A-60, A-70, A-80 and A-90. We hope this guide is informative to you and helpful to your service, and ultimately, to your sales activities.

# CONTENTS OF TROUBLESHOOTING POWER AMPLIFIERS

## I. Operation of Circuits

1. Development of Power Amplifiers .....	3
a) Single-Ended Push-Pull (SEPP) Amplifier .....	6
b) All-Stage Direct-Coupled SEPP Amplifier .....	7
c) All-Stage Direct-Coupled SEPP DC Amplifier .....	8
d) Non-Switching Amplifier (NSA) .....	9
e) Non-Switching Amplifier (with a DC-servo circuit) .....	10
2. Operation of NSA .....	11
a) Operation of Class-A and Class-B amplifiers .....	11
b) Switching distortion .....	12
c) Biasing NSA .....	13
d) Circuit of NSA (A-7) .....	13
e) Types of NSA bias circuits .....	15
f) Operation of DC servo circuit .....	17
g) Operation of A-7 .....	17
3. Circuits of Special Function .....	19
a) Differential amplifier .....	19
b) Cascode amplifier .....	20
c) Constant-current circuit .....	20
d) Bootstrap circuit .....	22
e) Darlington and complementary connections .....	23
f) Current mirror circuit .....	24
g) Parallel push-pull circuit .....	25

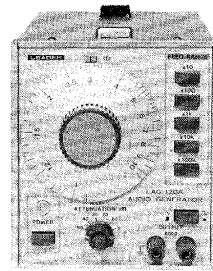
## II. Troubleshooting Guide

1. Typical Troubles in Repair Report .....	28
2. How do Troubles Occur? .....	28
a) How are transistors damaged? .....	28
b) The mechanism of defects — How are amplifiers damaged? .....	31
3. Troubleshooting Knowhow .....	35
4. Troubleshooting Power Amplifier .....	41
a) Primary fuse blows out .....	43
b) Fuse is all right, but no sound .....	46
c) Other troubles .....	52
1) Distortion .....	52
2) Noise .....	55
3) Intermittent sound when sound level is low .....	56
4) Click noise when powered on/off .....	56
5) Amplifier becomes hot even when the sound level is low .....	57

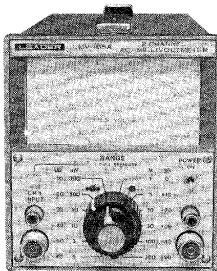
# MEASURING EQUIPMENT & DEVICES TO BE PREPARED



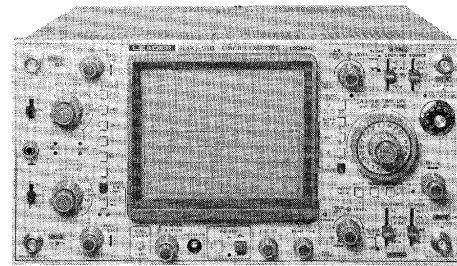
Multimeter



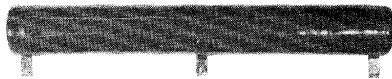
Audio Generator



mV Meter



Oscilloscope



Dummy Resistor ( $8\Omega$  50W – 100W) 2PCS

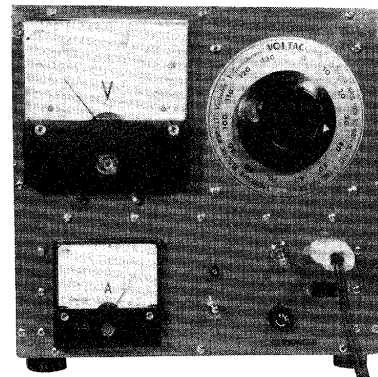


(Clip type)



(Stick type)

Multimeter leads



Voltage Regulator

# I. Operation of Circuits

## 1. Development of Power Amplifiers

In 1960, a transistorized amplifier was developed by TEC in U.S.A. In the more than twenty years since then, electronic technology has greatly been advanced and the performance of amplifiers has been incomparably improved, largely as the result of the invention of new amplifying elements (transistors) and circuits.

Silicon transistors and Single-Ended Push-Pull (SEPP) circuits have made the transistorized amplifier to be of high fidelity and very popular. Since then, the transistorized amplifier has been sophisticated step by step with various improvements. The following are the typical types of amplifiers developed.

- a) SEPP Amplifier
- b) All-Stage Direct-Coupled SEPP Amplifier
- c) All-Stage Direct-Coupled DC SEPP Amplifier
- d) Non-Switching Amplifier (NSA)
- e) NSA with DC servo circuit

It should be noted that each amplifier was developed on the basis of the previous ones. NSA, for example, was made on the basis of the all-stage direct-coupled SEPP DC amplifier, and further tracing back, the SEPP amplifier. Fig. 2 shows a simplified circuit diagram of the above amplifiers. You will find similar circuits in the various amplifiers.

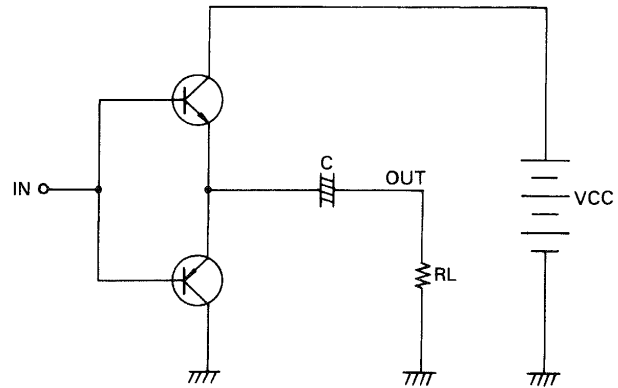


Fig. 1 SEPP circuit

Note: Single-Ended Push-Pull (SEPP) circuit

SEPP circuit is a push-pull circuit in which two transistors are connected serially DC-wise and in parallel AC-wise and the output of the positive half cycle and that of the negative half cycle are taken out of a common point. Being parallel AC-wise, the output impedance can be made low. Having low internal impedance, it can drive speakers directly. And it is being employed in most power amplifiers.

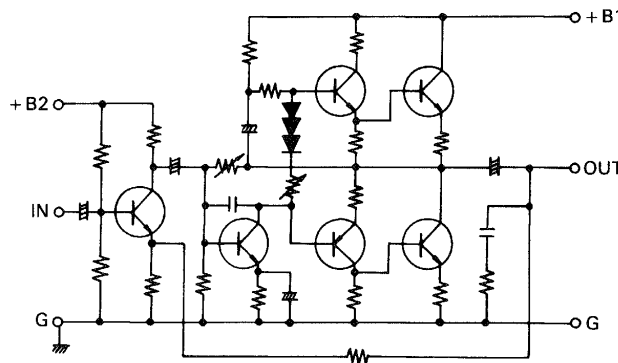
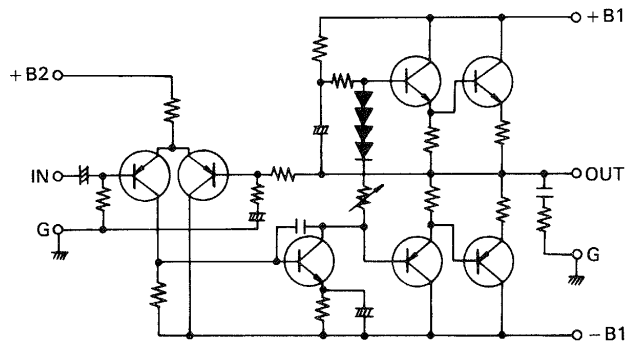
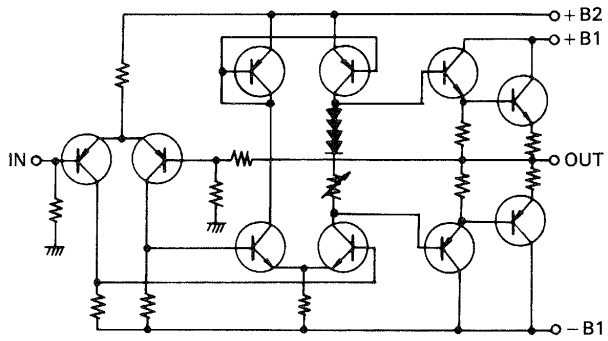


Fig. 2 Standard Single-Ended Push-Pull Amplifier



**Fig. 3 All-Stage Direct-Coupled SEPP Amplifier**



**Fig. 4 All-Stage Direct-Coupled SEPP DC Amplifier**

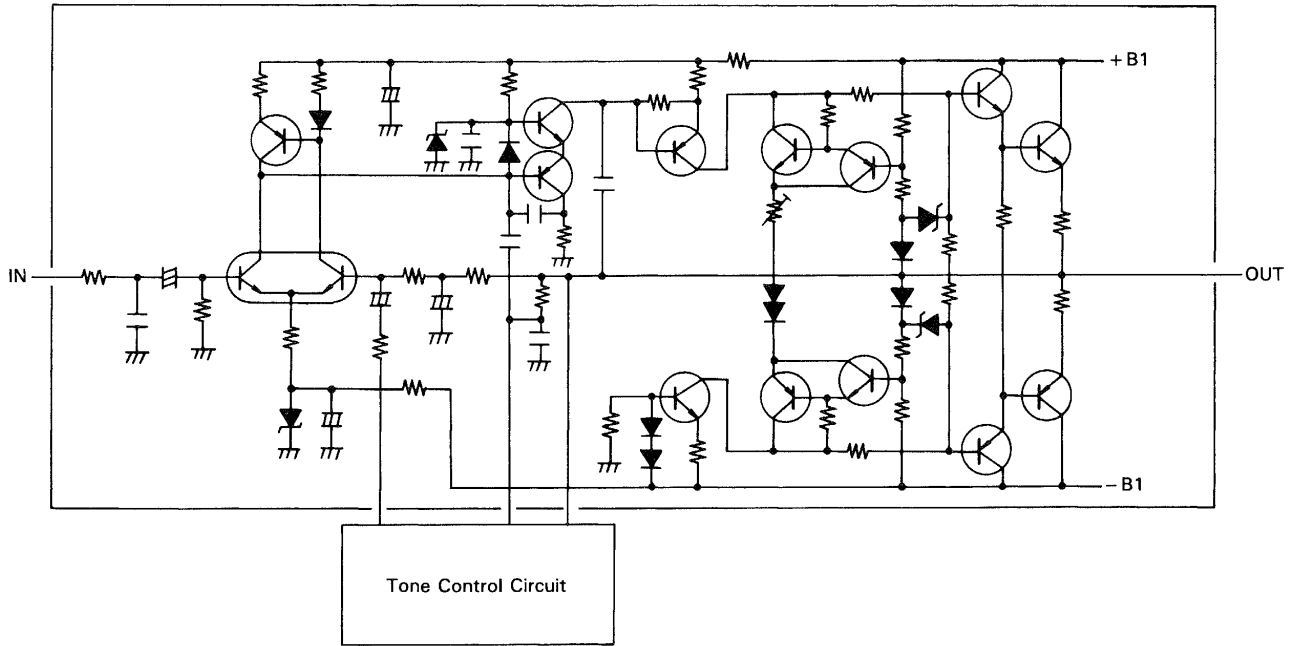


Fig. 5 Non-Switching Amplifier

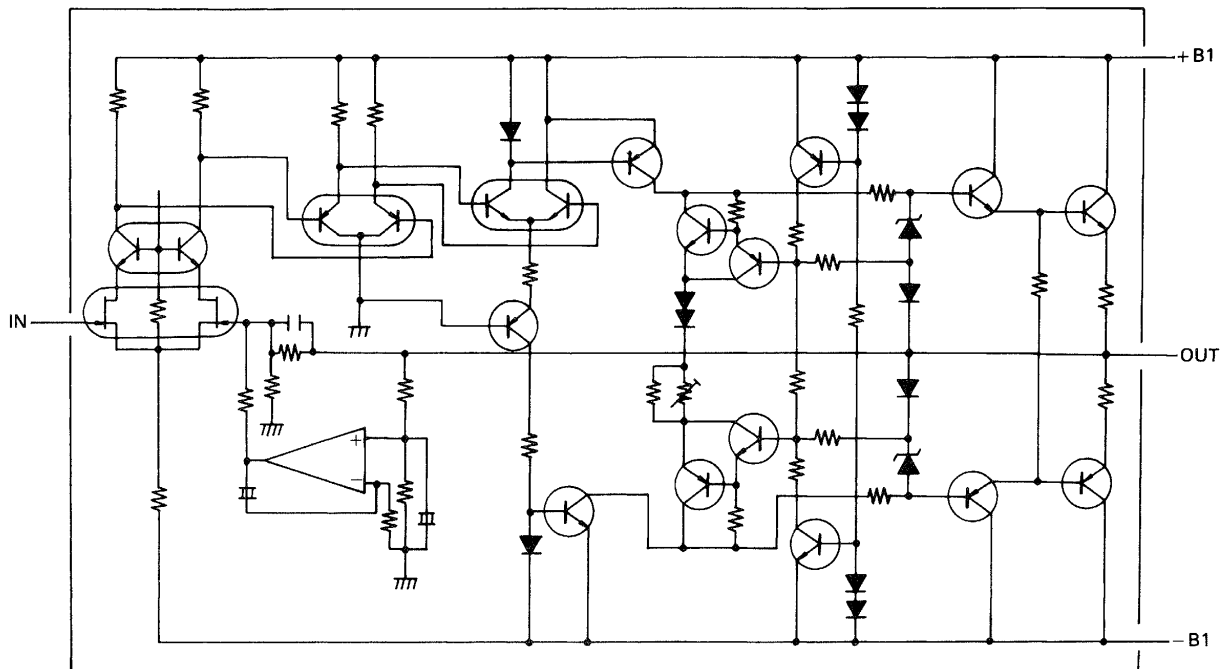


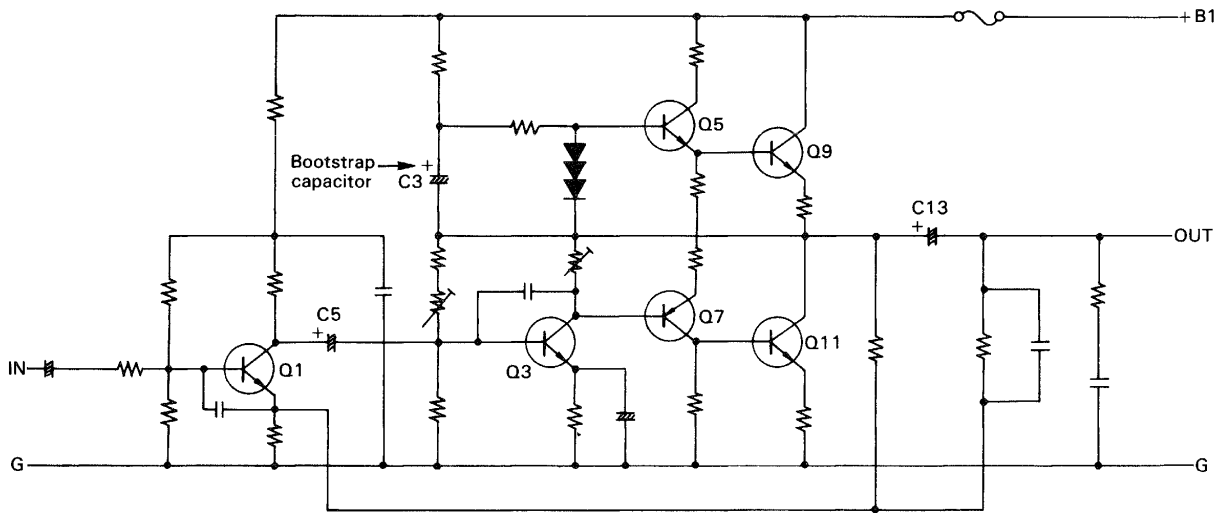
Fig. 6 Non-Switching Amplifier (with DC servo circuit)

**a) Single-Ended Push-Pull (SEPP) Amplifier**

Fig. 7 is the circuitry of the SEPP amplifier. The SEPP amplifier has comparatively good performance in spite of the simplicity of its circuitry. This has, however, the following demerits:

- (1) Two coupling capacitors on the signal route decrease frequency response in the low frequency range and stability, while increasing output impedance in the low frequency range, etc.

- (2) Phase inversion is made by the combination of PNP-NPN transistors. The asymmetrical amplification characteristic between the top and bottom transistors increases distortion in the high frequency range. This is because there were no drive and output PNP transistors of high performance in the high frequency range at that time.



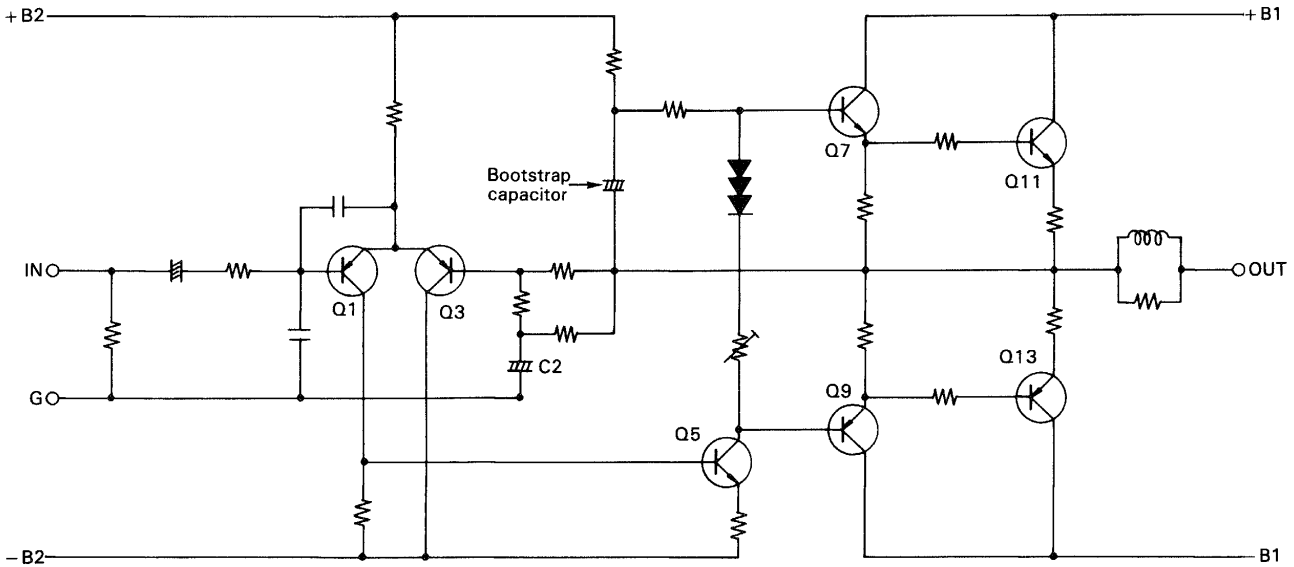
**Fig. 7 Standard SEPP Amplifier**



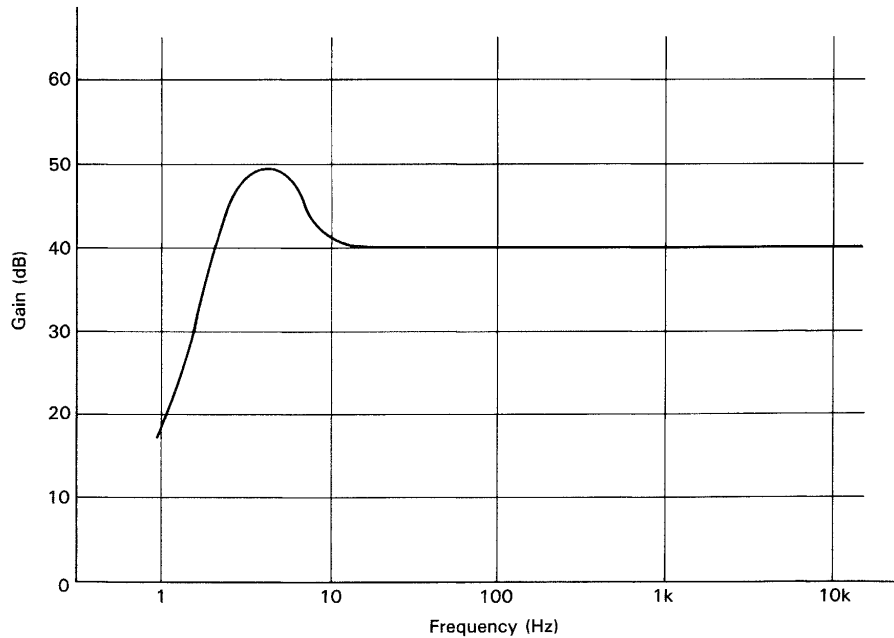
**b) All-Stage Direct-Coupled SEPP Amplifier**

Fig. 8 is the circuitry of the All-Stage Direct-Coupled SEPP Amplifier. To solve the above problems, All-Stage Direct-Coupled SEPP Amplifier has been developed. Having no coupling capacitor on the signal route, this amplifier can stably deliver negative feedback and increased response in the low frequency range, while decreasing

distortion. The gain, however, becomes nul in the DC and extremely low range. The remaining problem is the effect of the bootstrap capacitor which composes a kind of positive feedback circuit and causes uneven frequency characteristics. And strictly speaking, it turns the signal phase and makes the amplification astable.



**Fig. 8 All-Stage Direct-Coupled SEPP Amplifier**

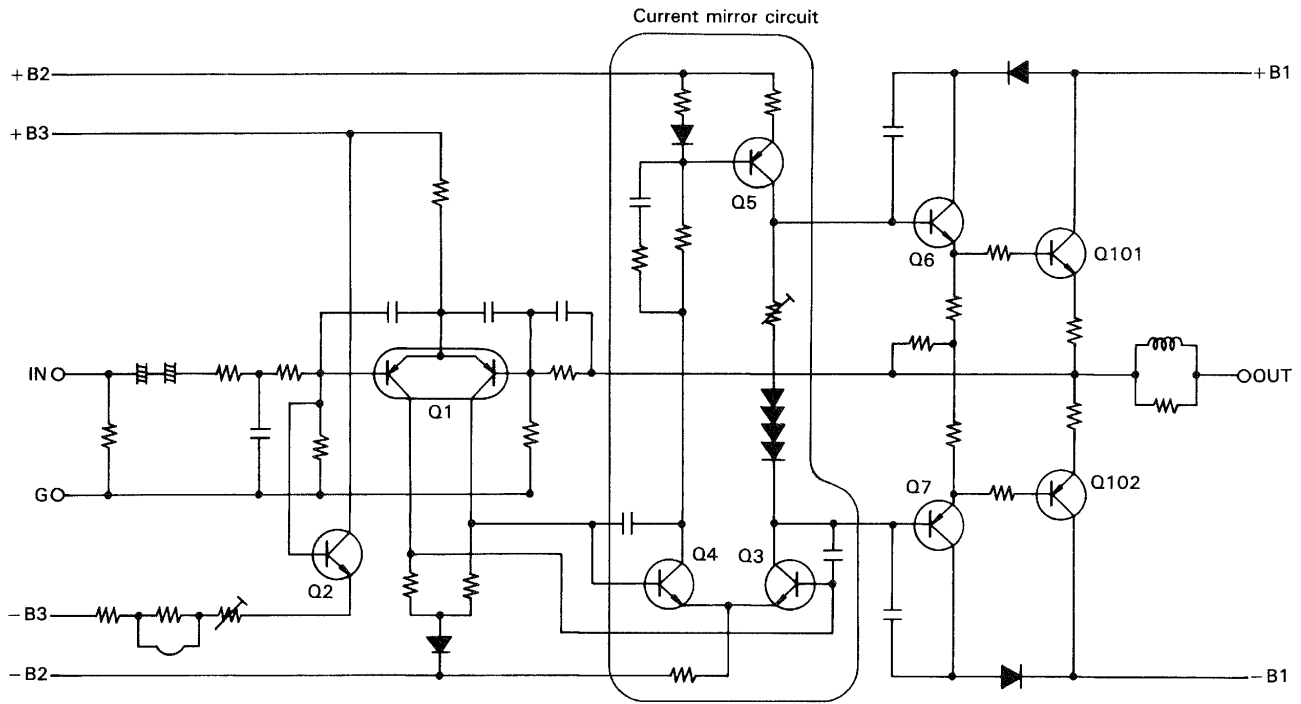


**Fig. 9 Frequency response of standard SEPP amplifier**

**c) All-Stage Direct-Coupled SEPP DC Amplifier**

Fig. 10 shows the circuitry of the All-Stage Direct-Coupled SEPP DC Amplifier. This improved circuit superseded the bootstrap circuit which had long been used in amplifiers. The negative feedback (NFB) amount of this circuitry against DC signal is equal to that against AC

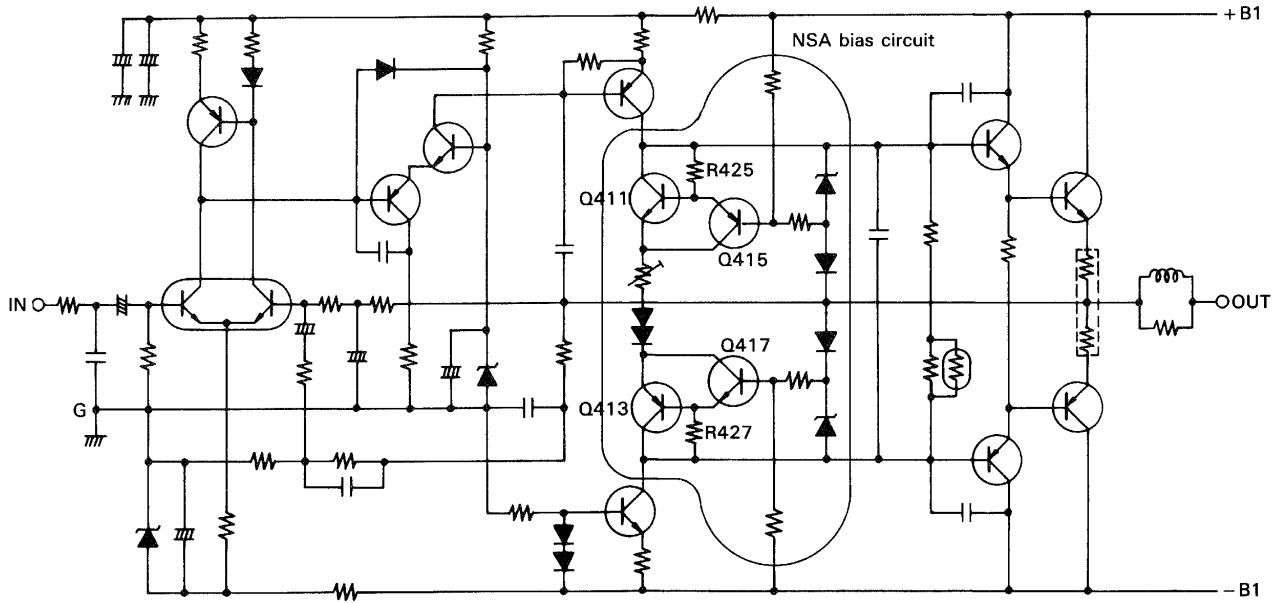
signal. Although this circuit amplifies the DC signal, DC components are blocked by a high-pass filter (HPF) at the amplifier's input. This circuit had widely been used until the next-generation NSA appeared.



**Fig. 10 All-Stage Direct-Coupled SEPP DC Amplifier**

**d) Non-Switching Amplifier (NSA) – Trademark of Pioneer**

The circuit consisting of Q411, Q413, Q415, Q417, R425 and R427 in Fig. 11 is called Non-Switching Amplifier. This has eliminated the switching distortion inherent in the conventional class B-SEPP amplifiers.

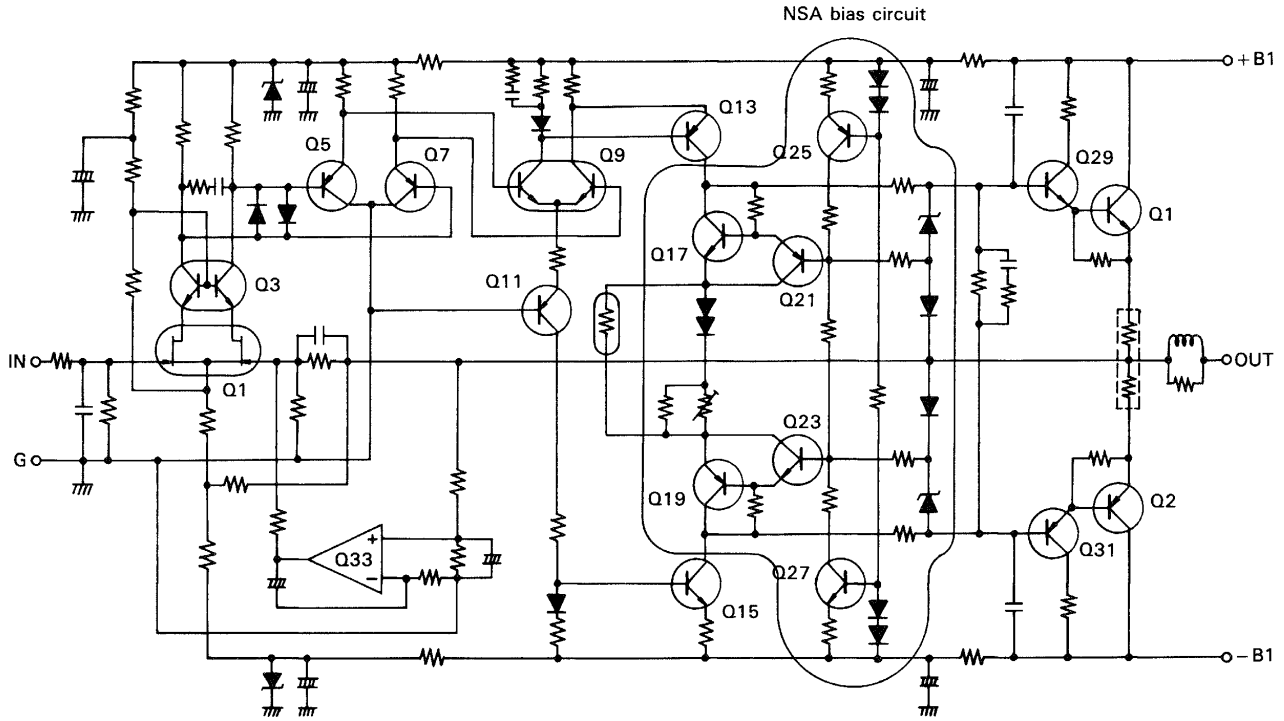


**Fig. 11 Non-Switching Amplifier**

**e) Non-Switching Amplifier (with a DC-servo circuit)**

This amplifier has an operational amplifier (op amp) in addition to the above. Q<sub>33</sub> amplifies only DC and extremely low frequency components, feeds it back negatively to the input, cancels the output DC offset

voltage and stabilizes the amplifier's operation. As a result, the DC gain becomes lower than 0 dB (smaller than 1).



**Fig. 12 Non-Switching Amplifier (with DC servo circuit)**

## 2. Operation of NSA

### a) Operation of Class-A and Class-B amplifiers

When the bias current of a transistor is adjusted to make the average collector current half of its maximum, the transistor operates in the active linear range, and distortion-free output is available as long as the input signal level is moderate.

Class-A amplifiers require large power transformers, large smoothing capacitors and large heat sinks, and they are inefficient, requiring a constant large current, and generating much heat. This circuit is employed in luxury models which pursue performance first, because its large components are quite expensive.

Because of the demerits of class A amplifier explained above, most of the amplifiers produced today are class-B. However, in class-B operation, output transistors are driven in the range including the non-linear range, and the recomposed output signals distorted at the connecting points as shown in Fig. 15. The distorted component is called crossover distortion.

To avoid the non-linear range, a collector current, or idle current, is applied.

In this way, crossover distortion can be eliminated. Accurate adjustment is required to get an optimum idle current.

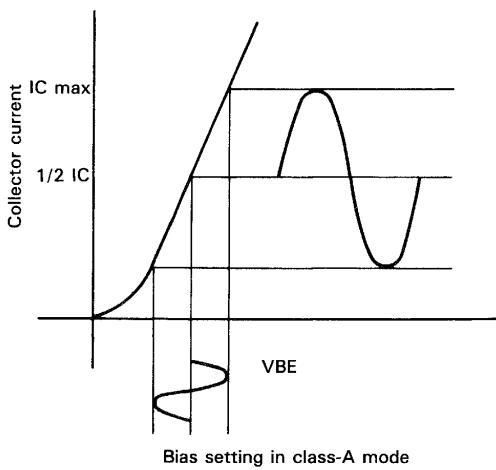


Fig. 13 Bias setting in class-A mode

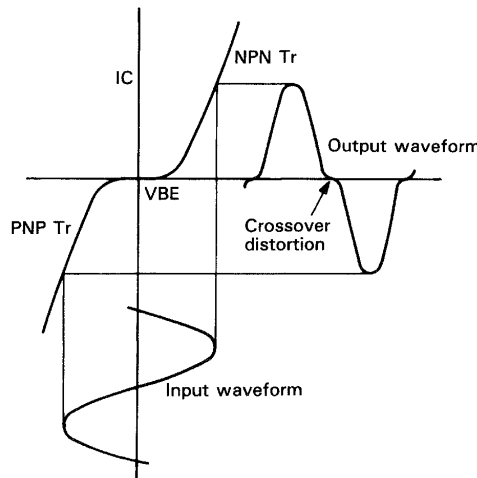


Fig. 14 Biasing in class-B mode

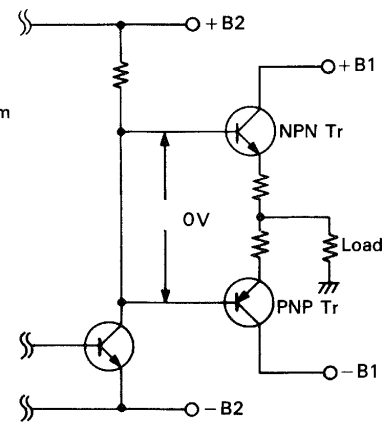


Fig. 15 Generation of crossover distortion

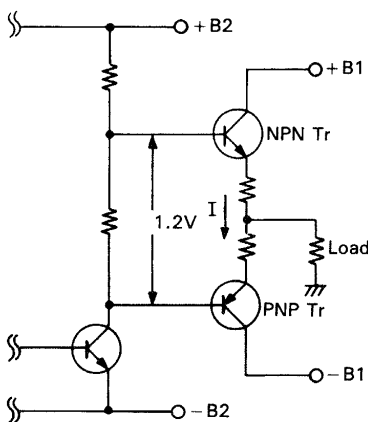


Fig. 16 Bias setting for idle current

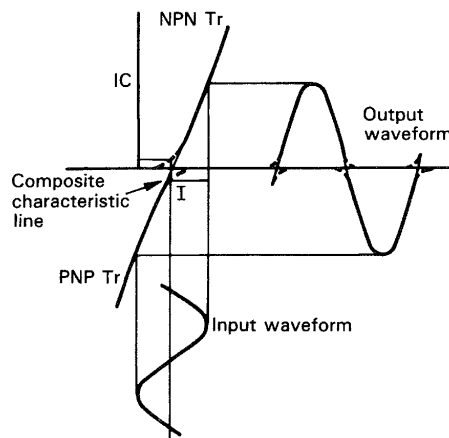


Fig. 17 Elimination of crossover distortion by flowing idle current

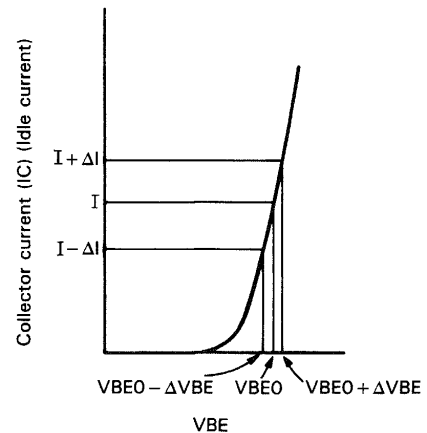


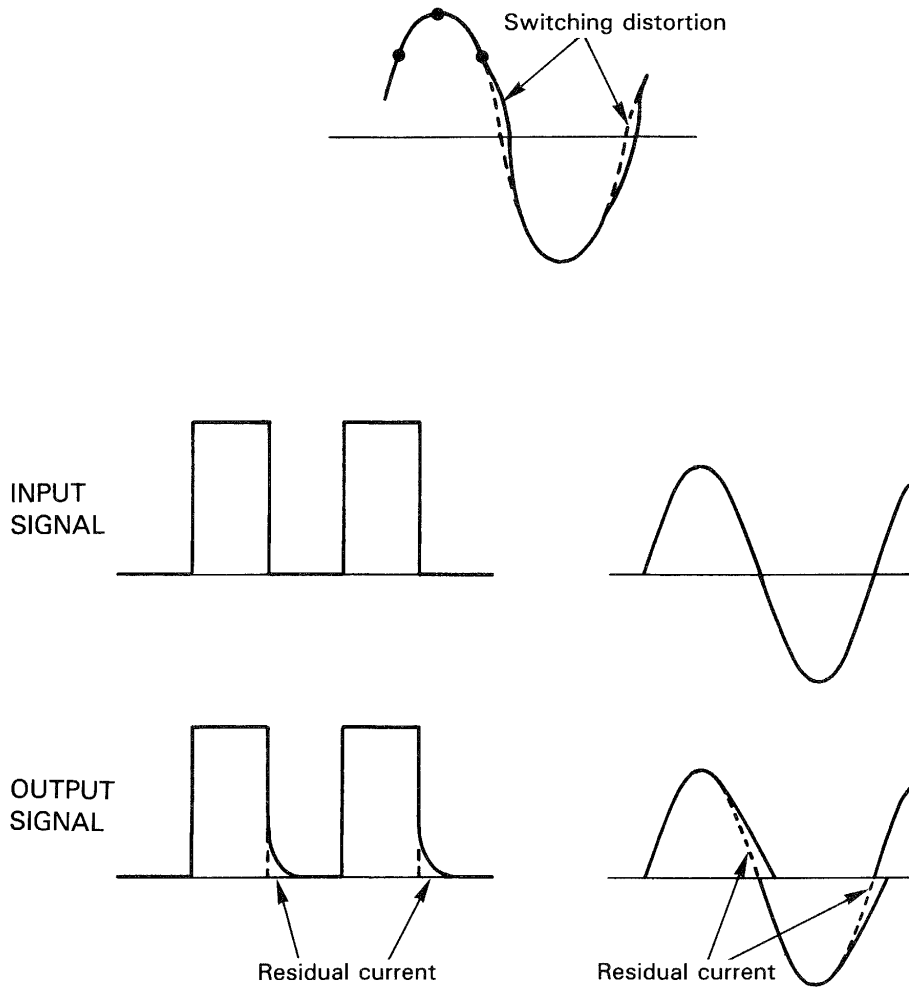
Fig. 18 Idle current setting

**b) Switching distortion**

In case of transistors which handle large amount of current, such as output transistors, the switching characteristic can sometimes cause a problem because of the storage effect inherent to transistors.

The current of electrons or holes can not follow the quick

signal variation in the high frequency range and stagnates at the base. And the collector current distorts as shown in Fig. 19. This is called switching distortion. This distortion cannot be eliminated by adjusting the idle current.



**Fig. 19 Generation of switching distortion**

### c) Biasing NSA

Switching distortion is inevitable as long as an amplifier is driven in class-B mode. To avoid it, NSA has been developed. The output transistors do not cut off all times and no switching distortion is generated.

#### Principle of non-switching amplifier

In the case of the conventional amplifiers, the bias is always fixed.

When the positive half cycle of a signal is put in the circuit of Fig. 20, a load current flows in the direction indicated by the arrow, and a voltage in proportion to the emitter current appears across  $R_{E1}$ . At this time, base potential becomes 0.6V higher than emitter potential. Here, the voltage between Q and R becomes nul or negative when that between P and Q becomes 1.2V or more. In other words,  $T_{R2}$  is inversely biased and turns off when the emitter current in  $R_{E1}$  increases and the voltage across  $R_{E1}$  exceeds 0.6V. The operation is similar in the period of negative half cycles.

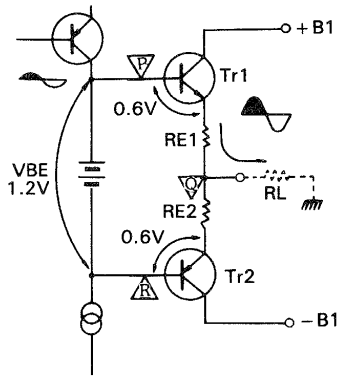


Fig. 20 Biasing of class-B Amplifier

### d) Circuit of NSA (A-7)

Non-switching amplifier has voltage detectors which sense the voltage exceeding 0.6V, increase bias voltage ( $V_P$  or  $V_R$ ) in proportion to the increase of the emitter voltage across  $R_{E1}$  or  $R_{E2}$  and prevent the transistors from being cut off. Fig. 22 shows the bias circuit employed in A-7.

When no signal is put in the circuit, the positive and negative voltages at the bases of  $Q_{21}$  and  $Q_{23}$  are kept at the level so that these transistors are almost cutoff. And the collector current of  $Q_{15}$  (= collector current of  $Q_{13}$ ) flows mostly through  $Q_{17}$ ,  $D_{11}$ ,  $V_{R1}$  and  $Q_{19}$ .

Let's see the operation of the circuit in Fig. 23 when the output power is 70W and the output signal reaches its positive peak. The peak values of voltage and current are:

$$V = \sqrt{PR} = \sqrt{70 \times 8} = 23.7 \text{ (V)}, \quad 33.5 \text{ (V max)}$$

$$I = \sqrt{\frac{P}{R}} = \sqrt{\frac{70}{8}} \doteq 2.96 \text{ (A)} \quad 4.2 \text{ (A max)}$$

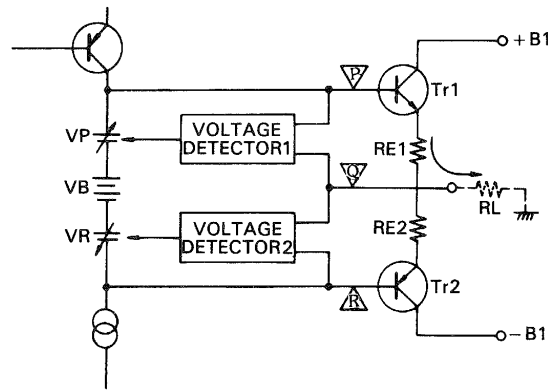


Fig. 21 Biasing of Non-Switching Amplifier

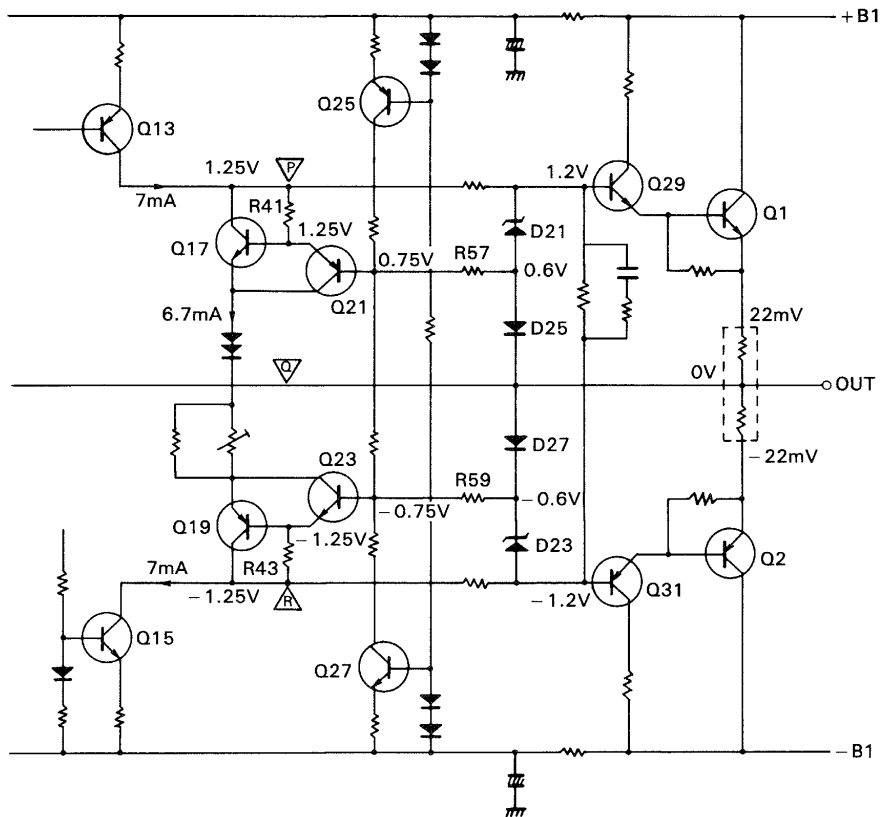


Fig. 22 Potential with no input

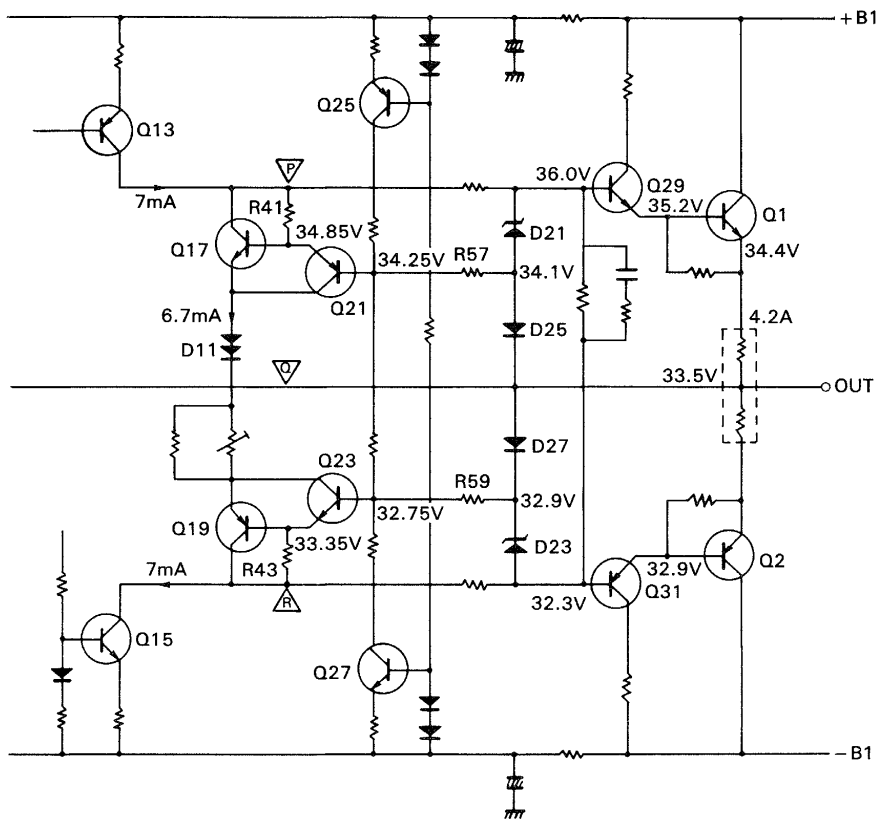


Fig. 23 Momentary potential at positive peak, 70W output



When the signal is at its peak, the potential on the center line becomes 33.5V while the potential at point P becomes 35.62V which is 2.12V higher than 33.5V due to the voltage drop by the emitter resistor (0.22V) of Q<sub>1</sub>. The current through R<sub>41</sub> increases and the current through Q<sub>17</sub> decreases.

Then the potential difference between points P and R increases by the amount of voltage dropped in the Q<sub>1</sub>'s emitter resistor.

On the other hand, the potential at R and Q<sub>31</sub>'s base varies little. Then, Q<sub>31</sub> and Q<sub>2</sub> are kept on, although their currents are small.

The operation in the negative collector half cycle is the same as above. At the negative peak, the voltage across R<sub>43</sub> increases the voltage between P and R and keeps Q<sub>29</sub> and Q<sub>1</sub> on.

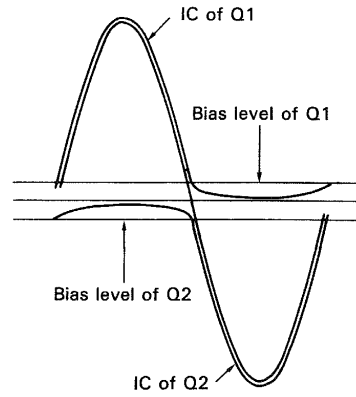


Fig. 24 Waveform of collector currents

**e) Types of NSA bias circuits**

There are three types of NSA bias circuits, classified by the power source:

- (1) From constant-current power source ..... A-7
- (2) From voltage-unregulated power source ..... A-6, SX-6
- (3) From voltage-regulated power source ..... A-70, A-80, etc.

- (1) In Fig. 25, power is supplied from constant current power source according to its principle. This has been employed in A-7, A-8, A-9, SX-8, SX-9, etc.
- (2) In Fig. 26, (1) has been simplified. This has been employed in A-5, A-6, SX-5, SX-6, SX-7, etc.
- (3) In Fig. 27, power is supplied from voltage-regulated power source. This has been employed in A-60, A-70, A-80, A-90, etc.

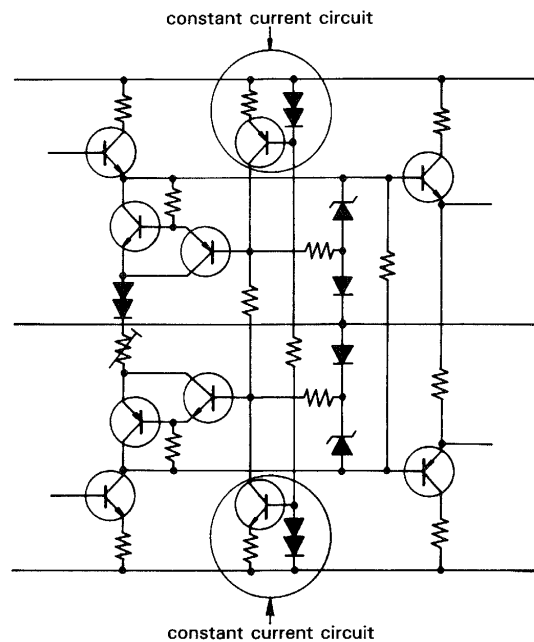


Fig. 25 Fed from constant-current power source

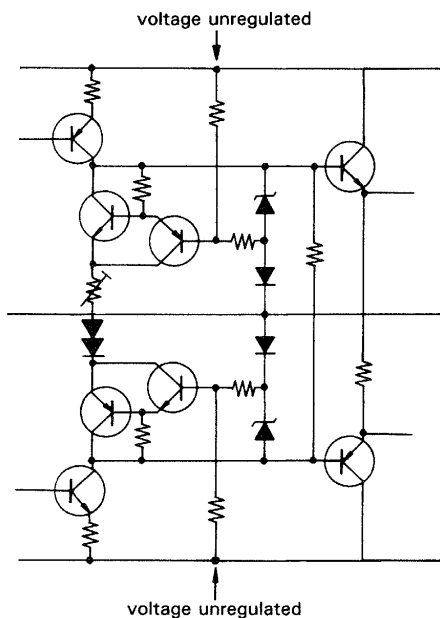


Fig. 26 Fed from voltage-unregulated power source

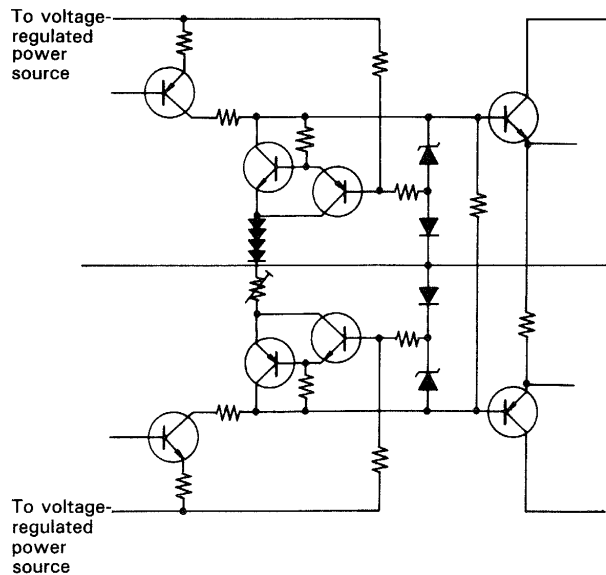
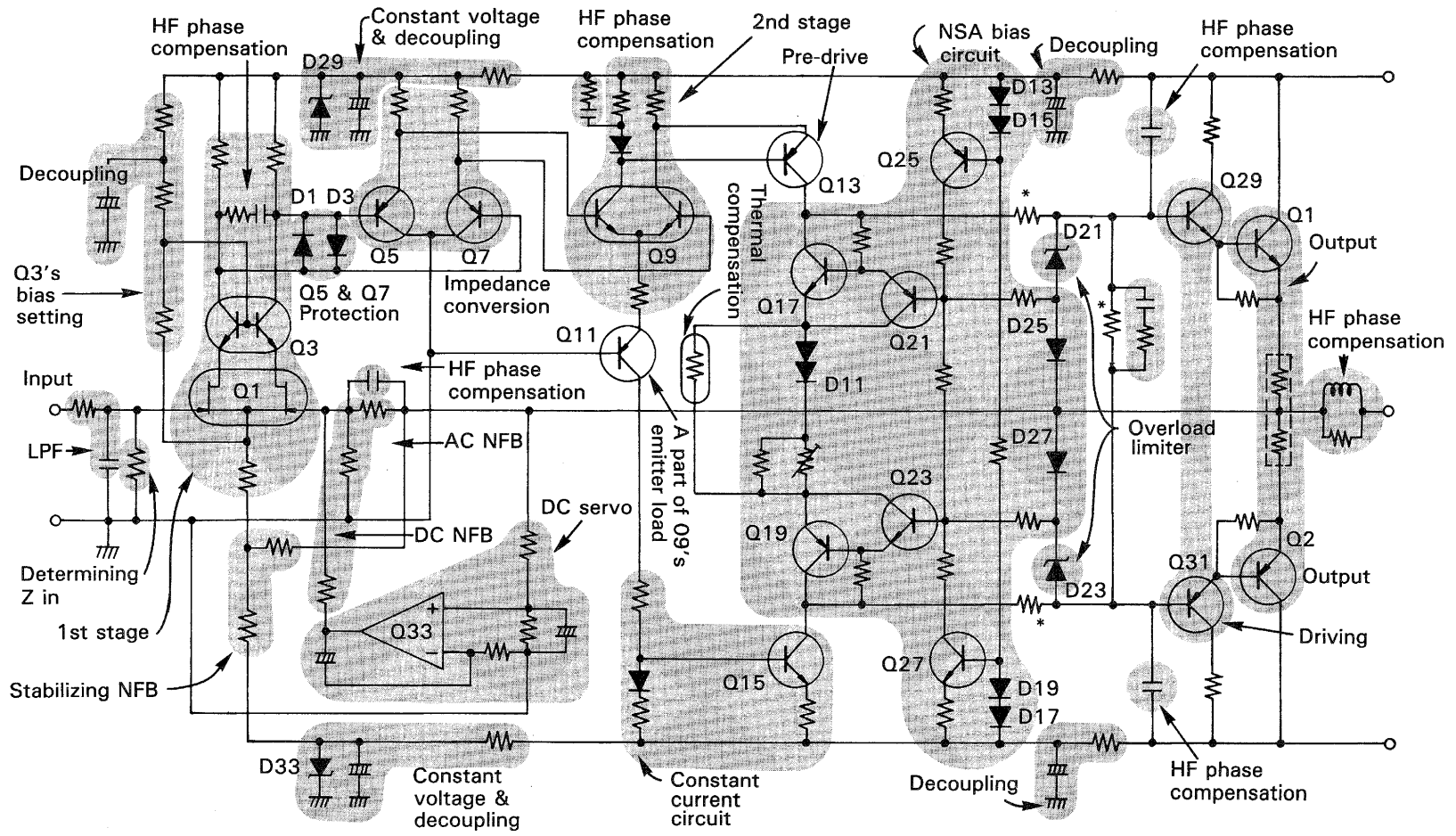


Fig. 27 Fed from voltage regulated power source

Fig. 28 Role of each part in A-7 power amplifier



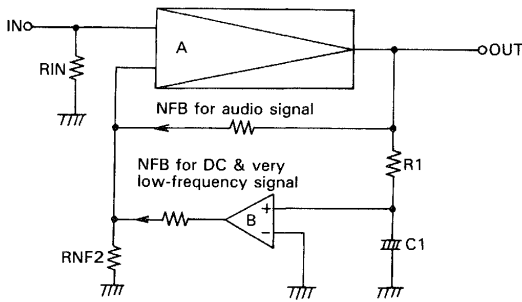
**f) Operation of DC servo circuit**

Fig. 29 shows the basic structure of an amplifier with a DC servo circuit which is added to the ordinary DC power amplifier.

Since the gain of DC amplifier is equal against both AC and DC, a large DC offset could arise if the circuit is unbalanced even a little.

In the DC servo amplifier, DC and extremely low frequency signals are filtered by  $R_1$  and  $C_1$ , and are amplified by B.

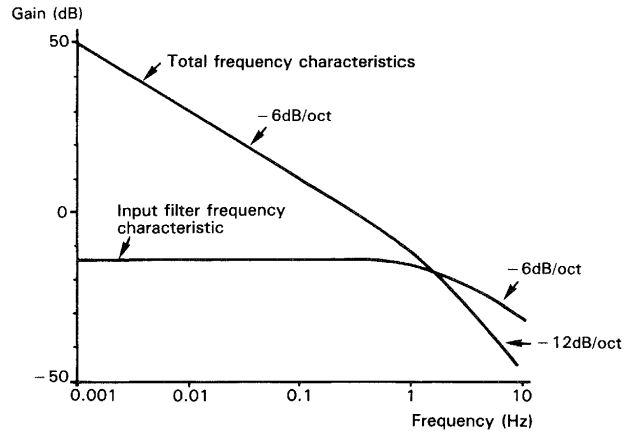
Then, the signals are fed negatively back to A. If a DC offset voltage appears, even if it is very small, the fed back voltage cancels the offset. Please note that the B's output has been sufficiently amplified.



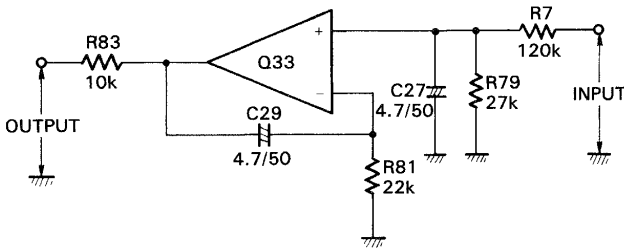
**Fig. 29 Basic operation of amplifier with DC servo circuit**

**g) Operation of A-7**

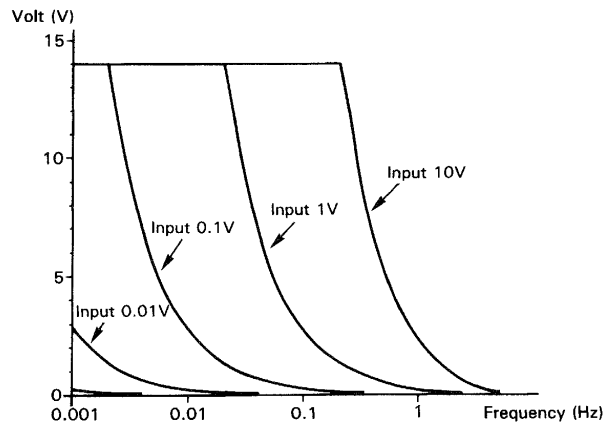
The servo circuit of A-7 consists of  $Q_{33}$  and its surrounding components.  $R_{77}$ ,  $R_{79}$  and  $C_{27}$  compose a low-pass filter for  $Q_{33}$  and block AC component. Further, the  $Q_{33}$  is an OP AMP which selectively amplifies DC and extremely low frequency signal only. The DC servo circuit and its characteristics are shown below:



**Frequency response**



**Fig. 30 DC servo circuit**



**Input/Output characteristics of DC Servo Circuit**

**Fig. 31 Frequency response and input/output characteristics of DC servo circuit**

The gain of the amplifier in Fig. 32 is determined by  $(R_1 + R_2)/R_1$ . In Fig. 33, the reactance of  $C_2$  becomes infinite when the signal frequency decreases to 0Hz (DC). Then the gain of  $Q_{33}$  becomes 100dB (open gain of  $Q_{33}$ ) and the output becomes almost equal to  $V_{cc}$  (+ or -14V). In A-7,  $C_2$  and  $R_1$  are 4.7/50 and 22k $\Omega$  respectively.

The gain of the entire DC servo circuit is shown in Fig. 29. A DC servo circuit is employed in A-7, A-8 and A-9 to stabilize DC output. Let's see how it works. If a positive DC offset voltage ①  $f$  appears at the output for some reason, it is divided by  $R_{77}$  and  $R_{79}$ , ②  $f$  is applied to the positive input of  $Q_{33}$  to be amplified, ③  $f$  appears in  $R_{83}$  and is applied to  $Q_1$ 's right gate, which is the negative feedback input, and the corrective voltages appear in the following stages as ④  $\searrow$  - ⑩  $\searrow$  to cancel the offset voltage as show in Fig. 33. If the DC offset voltage is negative, the direction of the corrective voltages will be reverse to those indicated.

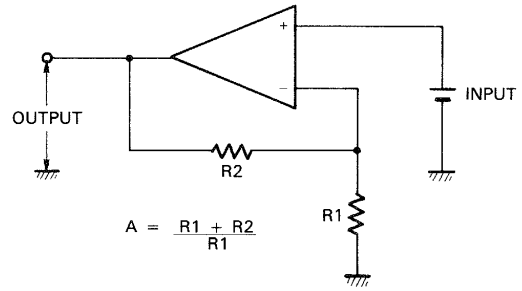


Fig. 32 Gain of OP amp (1)

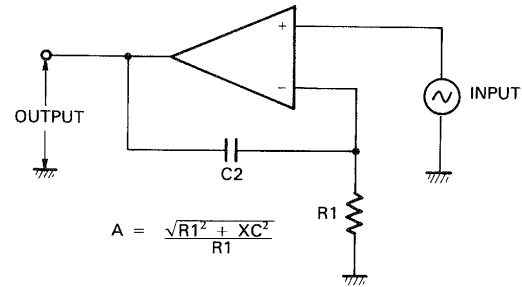


Fig. 33 Gain of OP amp (2)

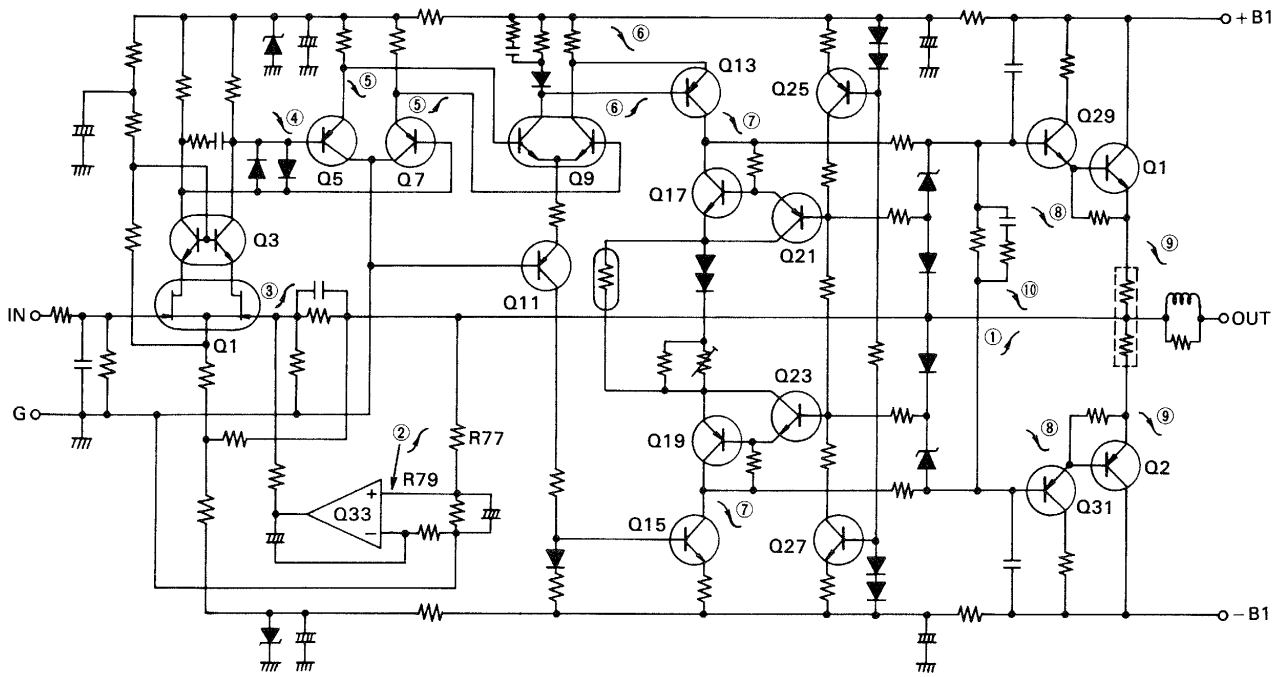


Fig. 34 Operation of DC servo circuit

### 3. Circuits of Special Function

#### a) Differential amplifier

Fig. 35 shows a typical differential amplifier composed of two transistors of equal characteristics and three resistors.  $R_E$  is the common emitter resistor for  $Q_1$  and  $Q_2$ . The values of collector resistors  $R_{c1}$  and  $R_{c2}$  are equal. The bases of  $Q_1$  and  $Q_2$  are input terminals. Output signal is taken out between terminals (A) and (B). This is called balanced differential amplifier.

When  $V_1$  and  $V_2$  are equal, collector currents of  $Q_1$  and  $Q_2$  are equal because  $Q_1$  and  $Q_2$  have the same characteristics. The voltage drop in  $R_{c1}$  becomes equal to that in  $R_{c2}$ . Then, the output voltage between (A) and (B) becomes nul and balanced.

When  $V_2$  becomes higher than  $V_1$ ,  $I_{B2}$  increases,  $I_{c2}$  increases, the voltage drop across  $R_{c2}$  increases, the potential at (B) falls, the voltage drop across  $R_E$  increases,  $V_E$  rises, the  $V_{BE}$  of  $Q_1$  decreases,  $Q_1$ 's collector current decreases, and the potential at (A) rises. When  $V_2$  is smaller than  $V_1$ , the voltages mentioned above become inverse.

The merits of differential amplifier are;

- 1) High gain
- 2) Low distortion
- 3) Insensitive to noise from power supply

Thus in a differential amplifier,  $Q_1$  and  $Q_2$  work as a see-saw and even a very small level difference between the two inputs brings a high output. And further, the output distortion is very low because both of  $Q_1$  and  $Q_2$  are driven in the linear range.

Application of differential amplifier — Automatic control of the center line potential.

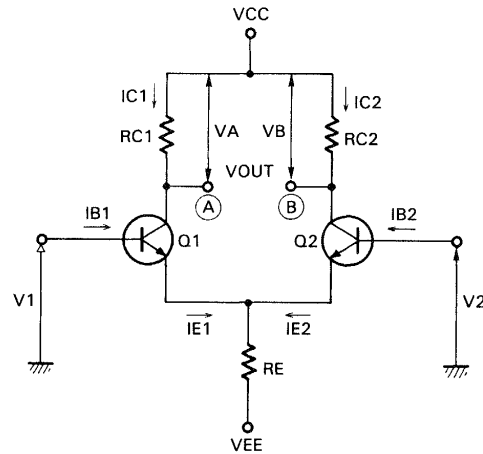


Fig. 35 Differential amplifier

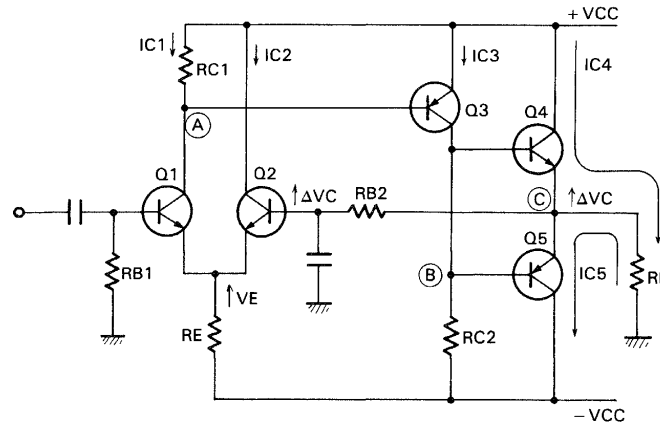


Fig. 36 Operation of DC offset cancellation

When a DC offset appears on the center line, a DC current flows through the speaker, and the speaker may be damaged.

Therefore, a circuit that can cancel DC offset at the output is required. If the  $Q_1$ 's base potential is 0V DC and the center line potential rises by  $\Delta V_c$ , a DC offset on the center line (C) arises for same reason, the potential at (A)

rises as discussed above,  $Q_3$ 's bias voltage decreases, and  $Q_3$ 's collector current,  $I_{c3}$ , decreases. Also, the potential at (B) goes down,  $Q_4$ 's bias is decreased and  $Q_5$ 's bias is increased,  $I_{c4}$  decreases and  $I_{c5}$  increases, and finally, the center line potential is pulled down to keep it balanced at 0V.

## b) Cascode amplifier

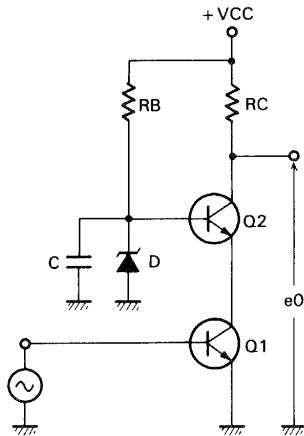


Fig. 37 Cascode amplifier

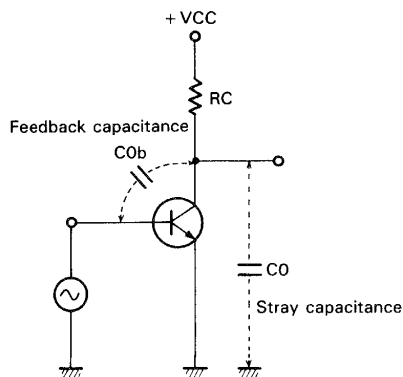


Fig. 38 Existence of equivalent capacitance

In a cascode amplifier, the output of one stage is connected serially to the input of the next stage as shown in Fig. 37.

Generally, an emitter-grounded transistor circuit has a feedback capacitance between collector and base and a stray capacitance between collector and ground. The capacitance reduces the linearity of the high frequency response and causes distortion.

By connecting the output of emitter-grounded  $Q_1$  to the input of base-grounded  $Q_2$ , the input impedance of this circuit can be decreased, the effect of the capacitances, feedback capacitance and stray capacitance on the high frequencies can be minimized, the linearity at the high frequency range can be improved, and thus distortion can be minimized.

Further, by connecting as shown in Fig. 39, the distortion caused by DC voltage fluctuation between collector and emitter ( $V_{CE}$ ) can be minimized, and the  $V_{CE}$  of  $Q_1$  can be adjusted by varying  $V_{CE}$  of  $Q_2$ . This connection makes it possible to use transistors of low withstanding-voltage and good characteristics.

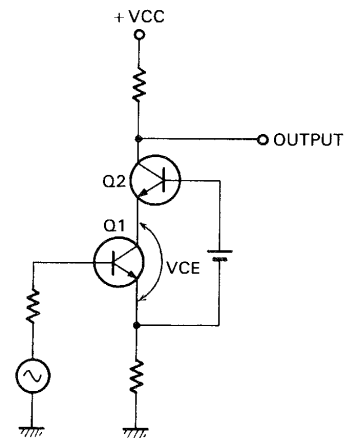


Fig. 39  $V_{CE}$  setting of cascode amplifier

## c) Constant-current circuit

In the emitter-grounded circuit shown in Fig. 40, the load resistance for the transistor AC-wise is the combined resistance of  $R_c$  and  $R_L$ , which are connected in parallel. To increase the gain, keeping the resistance of  $R_L$  constant, it is necessary to increase  $R_c$  or  $I_c$ . This, however, is not recommended because increasing them causes much voltage loss in  $R_c$ . It is ideal to have a load of infinite impedance that allows a certain amount of constant current.

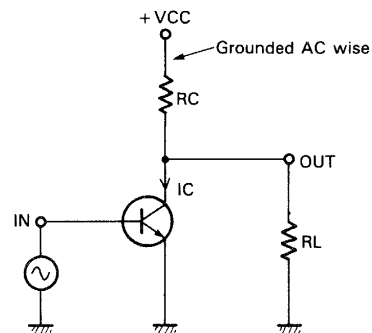


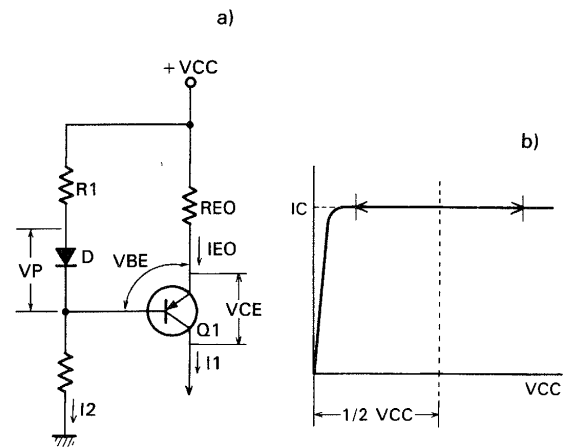
Fig. 40 Emitter-grounded amplifier

In Fig. 41 (a), when the base potential is made constant with  $R_1$  and  $D$ , a constant current flows in the transistor. If the constant current circuit is used as the load for a transistor, the characteristic of Fig. 41 (b) can be obtained. Normally the  $V_{CE}$  determined is half of  $V_{CC}$ . The figure shows that the current stays constant even when the  $V_{CE}$  varies. The constant-current circuit satisfies the following equations.

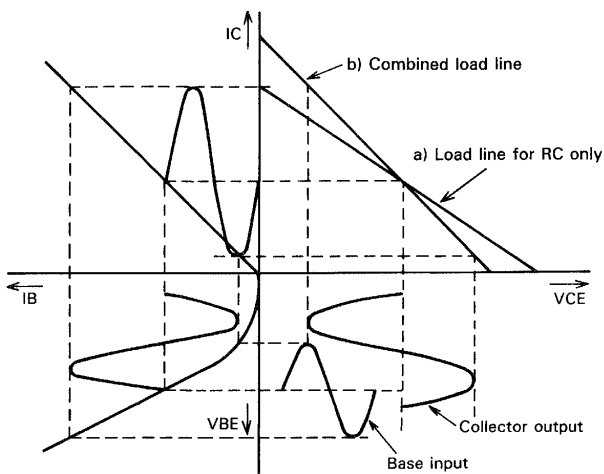
$$\frac{I_1}{I_2} = \frac{R_1}{R_{EO}} \quad \therefore I_1 = \left(\frac{R_1}{R_{EO}}\right) I_2 \doteq I_{EO}$$

$$I_2 = \frac{V_{CC}}{R_1 + R_2} \quad \therefore I_{EO} = \frac{R_1}{R_{EO}} \left(\frac{V_{CC}}{R_1 + R_2}\right)$$

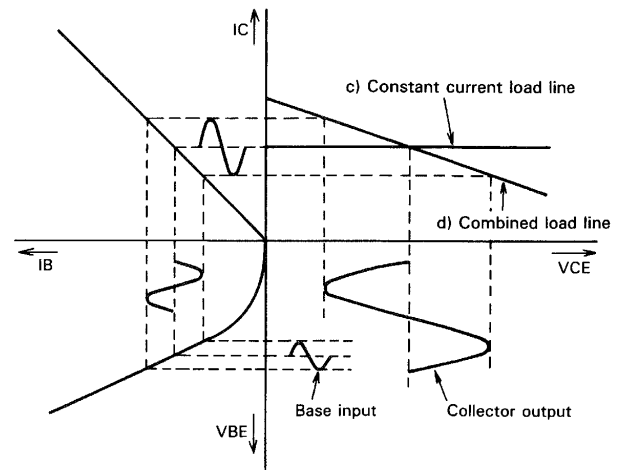
Provided  $V_{BE} = V_D$   
 $I_2 \gg I_B$



**Fig. 41  $V_{CC} - I_C$  Constant-current circuit and characteristic**



**Fig. 42 Characteristics with ordinary resistor load**



**Fig. 43 Characteristics with constant-current load**

Fig. 42 show the relation among base current, collector current, load line and collector output. Here, a) shows the load line without  $R_L$  while b) shows the load line with  $R_L$  connected. In Fig. 43, c) shows the load line in case a constant current circuit is employed instead of RC, and

d) shows the load line with the following stage combined to the amplifying circuit shown in Fig. 44. The largest advantage of employing this circuit is that a very high gain can be obtained.

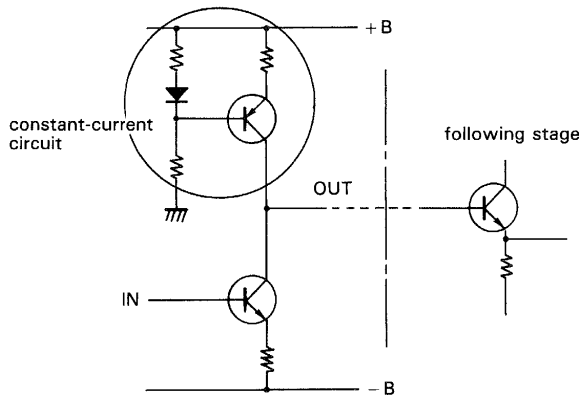


Fig. 44 Amplifying circuit with constant-current load

#### d) Bootstrap circuit

The bootstrap circuit is a circuit used to increase the input impedance by employing a kind of positive feedback.

In Fig. 45,  $R_{11}$  is grounded AC-wise at the top via +V<sub>CC</sub> line with large capacitors in power supply block. Actually in this case,  $Z_{i3}$ , the combined impedance of the stages after  $Q_3$  against positive input signals, is further combined with  $R_{11}$ . Refer to Fig. 47. In the period of positive half cycle, the following equation is satisfied:

when  $hfe_3 = hfe_5 = hfe$ ,

$$Z_{i3} = hfe^2 \times R_L$$

Therefore, when  $hfe = 50$ , and  $R_L = 8\Omega$ ,  $Q_2$ 's load impedance  $R_{i2}$  becomes:

$$R_{i2} = \text{Parallel connection of } R_{11} \text{ and } Z_{i3} \\ = \frac{5 \text{ (k}\Omega) \times 50^2 \times 8 \text{ (}\Omega)}{5 \text{ (k}\Omega) + 50 \times 8 \text{ (}\Omega)} = 4 \text{ (k}\Omega)$$

It is equivalent to have a 20k $\Omega$  impedance added in parallel to the 5k $\Omega$  load resistor, and the total load becomes 4k $\Omega$ .

When a bootstrap circuit as shown in Fig. 46 is employed, the impedance AC-wise becomes:

Total impedance of  $Z_i$  (3+5) and  $R_{10}$  connected in parallel

$$\frac{\text{Total impedance of parallel } Z_i \text{ (3+5) and } R_{10}}{\text{Total impedance of parallel } R_{11} \text{ and } R_L}$$

$\therefore Z_i$  (3+5): Total input impedance of  $Q_3$  &  $Q_5$  connected

Here,  $R_{11}$  can be disregarded because

$$R_{11} \gg R_L$$

The impedance of  $Q_3 + Q_5$  is:

$$R_{ie3} = h_{ie3} + h_{FE} \cdot h_{ie5}$$

And  $Q_2$ 's actual load impedance ( $R_{e12}$ ) is:

$$R_{i2}' = \frac{R_{10} (h_{ie3} + h_{fe} \cdot h_{ie5})}{R_{10} + (h_{ie3} + h_{fe} \cdot h_{ie5})} + h_{fe}^2 + R_L$$

because the combined impedance of  $Q_3$  and  $Q_5$  is

$$\frac{5 \times 1}{5 + 1} + 20 = 20.8 \text{ (k}\Omega)$$

If  $h_{ie3}$ : 250 $\Omega$   $h_{ie5}$ : 15 $\Omega$   $h_{fe}$ : 50

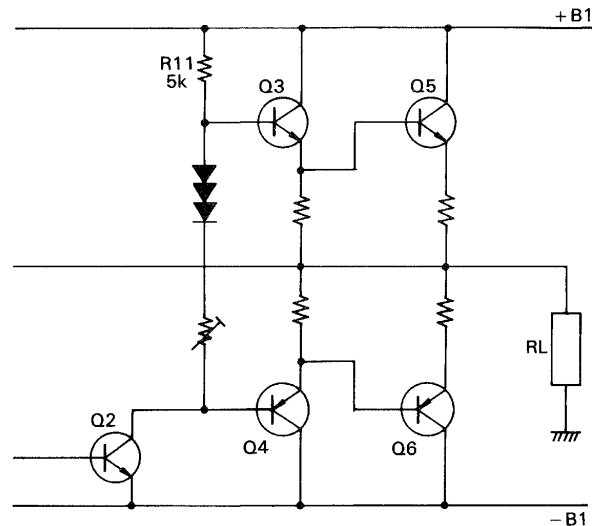


Fig. 45 Power Amplifier without bootstrap circuit

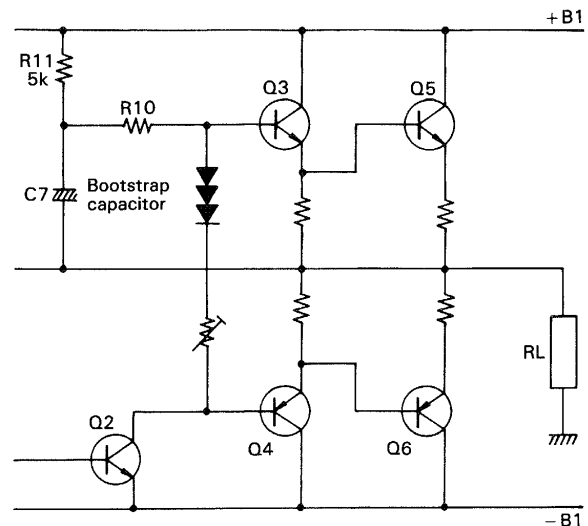


Fig. 46 Power Amplifier with bootstrap circuit. Refer to Fig. 48.



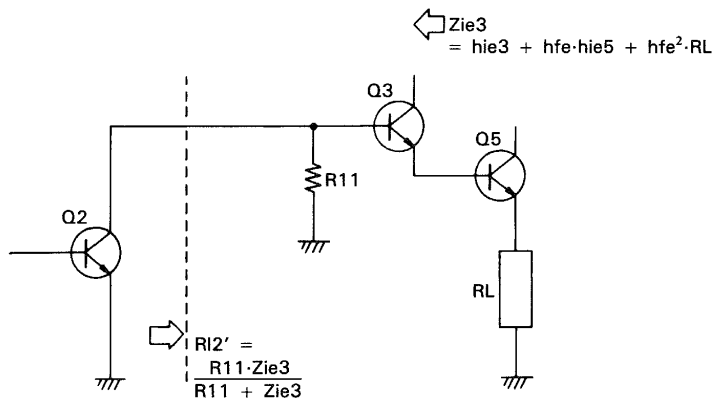


Fig. 47 Load of Q<sub>2</sub> without bootstrap circuit

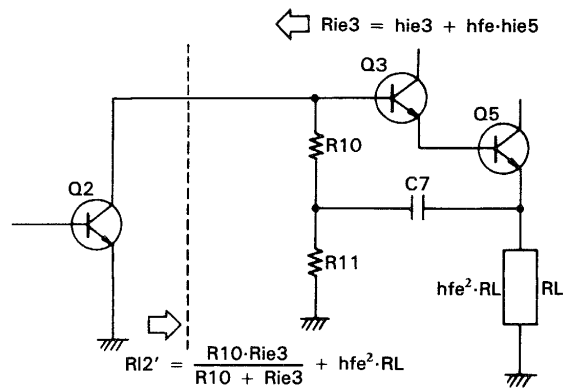


Fig. 48 Load of Q<sub>2</sub> with bootstrap circuit

e) Darlington and complementary connections

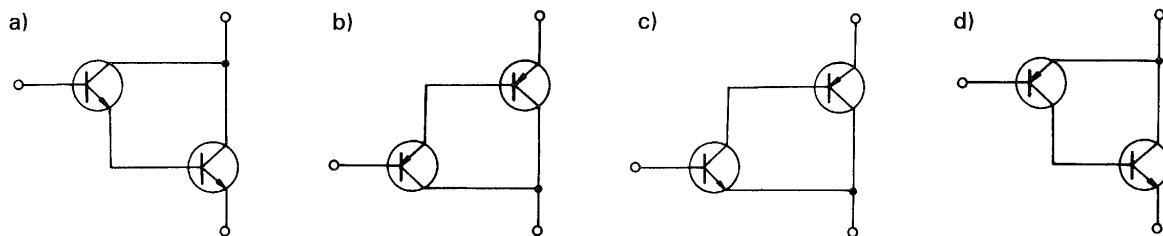


Fig. 49 Darlington connection

Circuit a) consists of two transistors of the same type. Their collectors are tied together and the emitter of the first transistor is directly connected to the base of the second. The emitter current of the first transistor equals the base current of the second.

Circuit b) consists of two transistors of inverse type. By connecting transistors like these, the combined hfe of the both transistors becomes the multiplied value of both hfes, and a large AC current can be obtained at the collector or emitter with a small base current. In Fig. 50, the necessary base current required to obtain 1A emitter current is 0.1mA. These are popularly employed in driver-power stages of audio amplifiers because a large transistor current is required for driving a speaker.

c) and d) are complementary connections, and they function similarly to Darlington connections.

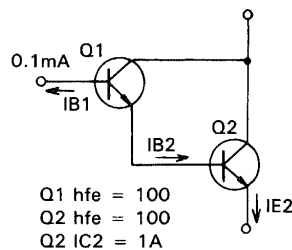


Fig. 50 Current of Darlington circuit

**f) Current mirror circuit**

The current mirror circuit, consisting of four transistors and three resistors, is shown in Fig. 51. It produces currents symmetrically through  $Q_1$  and  $Q_2$ .  $Q_1'$  and  $Q_2'$  are employed as the load of  $Q_1$  and  $Q_2$  which compose a differential amplifier. When (1) rises, (3) rises, bias voltage of  $Q_2$  decreases, collector current of  $Q_2'$  decreases, (4) rises, (5) rises, then, the internal resistance of  $Q_1'$  increases and (6) falls. Of course, the same current flows through  $Q_1$  and  $Q_1'$ .  $Q_1$  pulls (2) down, and  $Q_1'$  pulls it down further.

This is a push-pull operation. Thus, the amplification is doubled.

In the case of a simple differential amplifier, rising potential at (1) pulls the potential at its collector, but  $Q_2$  does not contribute amplification.

Fig. 52 shows a transistor differential amplifier employed in the first stage of an audio amplifier.

In Fig. 52, to keep the base potential of  $Q_1$  and  $Q_2$  ( $E_{B1}$  &  $E_{B2}$ ) balanced,  $R_{B2}'$  should be equal to the combined resistance of  $R_{B2}$  and  $R_{NF}$  because:

$$I_{C1} = I_{C2} = h_{FE} \times I_{B1}, I_{C2} = h_{FE} \times I_{B2}$$

( $h_{FE}$  of  $Q_1$  is equal to that of  $Q_2$ .)

$$I_{B1} = I_{B2}$$

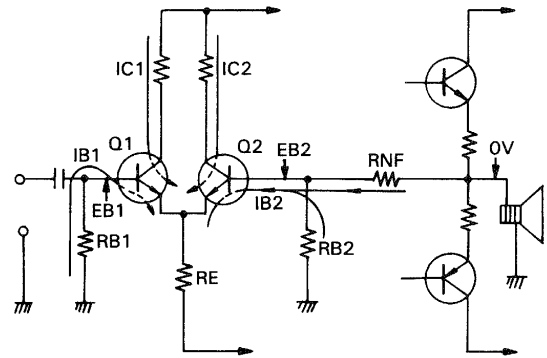
Then, the following should be satisfied to make  $E_{B1} = E_{B2}$ :

$$R_{B1} = R_{B2}'$$

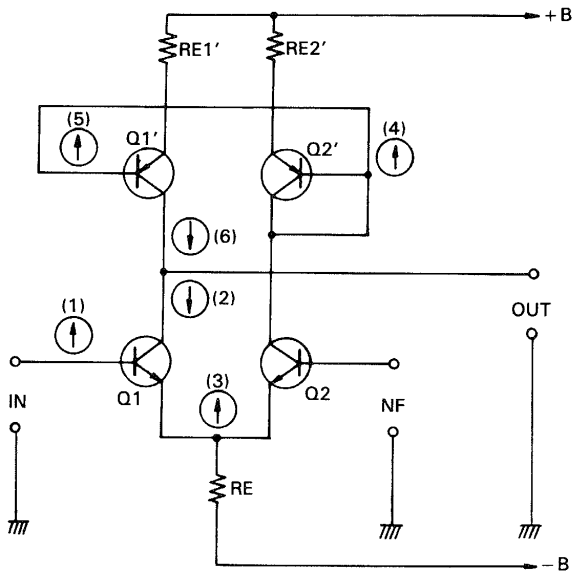
$R_{B2}'$ : Combined resistance of  $R_{B2}$  and  $R_{NF}$

$R_{B1}$  should be made lower than  $R_{B2}$  (about  $1k\Omega$ ) to keep the balance of base potential. The input impedance of a transistor itself is low because it allows base current to flow. Then, the input impedance of the above circuit becomes too low to employ in audio equipment.

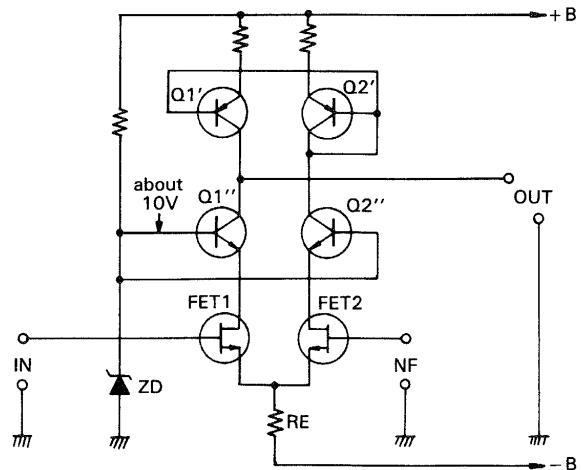
To make input impedance high, recent All-stage Direct-coupled DC Amplifiers employ FETs instead of transistors at the input stage because FETs do not allow gate current, resulting in high input impedance. FETs can not be driven by power sources of more than 15V or thereabout since they allow gate current when drain-source voltage is higher than that value. Usually, a cascade connection is employed as shown in Fig. 53 to prevent excessive voltage.



**Fig. 52 1st-stage of All-stage Direct-coupled DC Amplifier**



**Fig. 51 Current mirror circuit in the input stage**

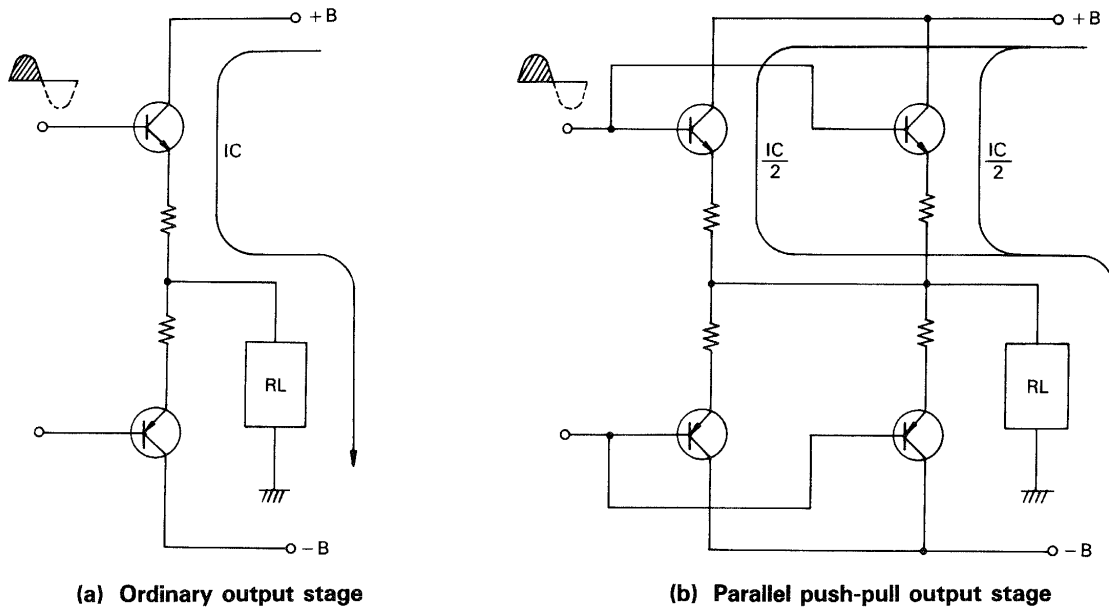


**Fig. 53 Input stage circuit employing FETs.**

**g) Parallel push-pull circuit**

To increase the power of an amplifier is to increase the current in power transistors and speakers. The parallel push-pull circuit has been developed to increase the power output without increasing the current per transistor, by letting four transistors cooperate. By adding a pair of

transistors of equal characteristics in parallel to the ordinary SEPP circuit as shown in Fig. 54 (b), the current in the load can be divided into two and the current in each transistor can be made half of that in the load.



**Fig. 54 Output circuit**

Generally, the characteristics of  $h_{fe}$  and  $f_T$  (transition frequency) versus collector current are not linear as shown in Fig. 55 and Fig. 56. They decrease rapidly at the high frequency range. The characteristics also differ depending on the type of transistor, NPN or PNP. The difference in characteristics causes distortion in the SEPP stage. Distortion can be reduced by employing a para-

push connection and feeding half of the load current to a power transistor. When the current is divided into two, the current variation per transistor becomes half, and the range of total collector current variation is narrowed. The parallel connection also improves transistors' heat dissipation, reducing their thermal resistance by half, and allowing production of smaller heat-sinks.

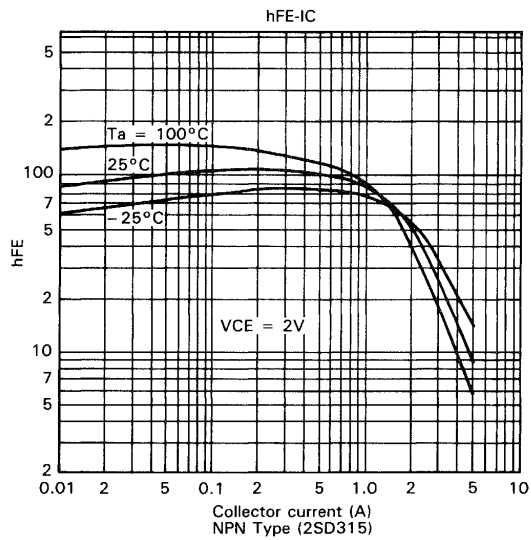
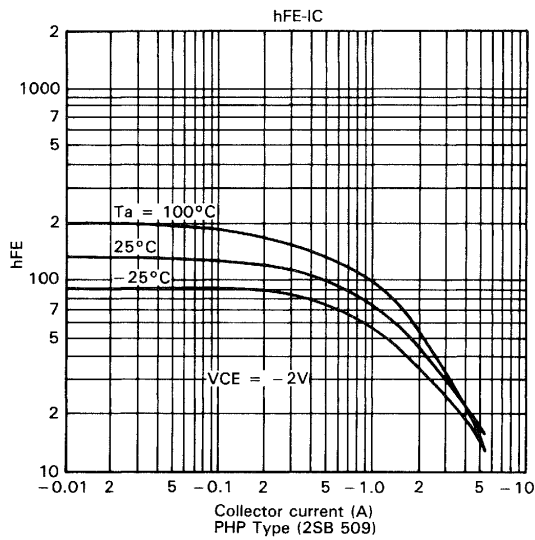


Fig. 55  $h_{FE}-I_C$  characteristic

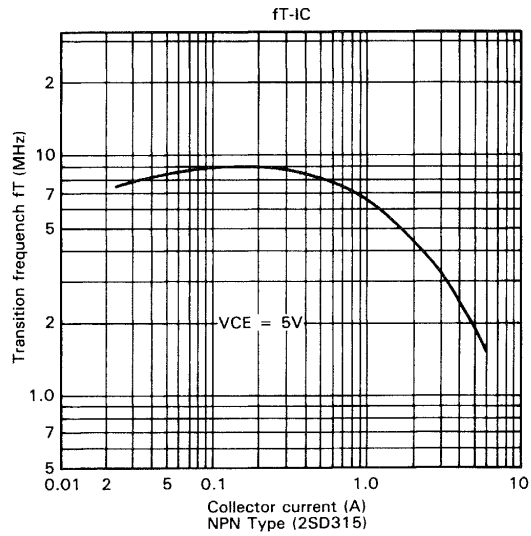
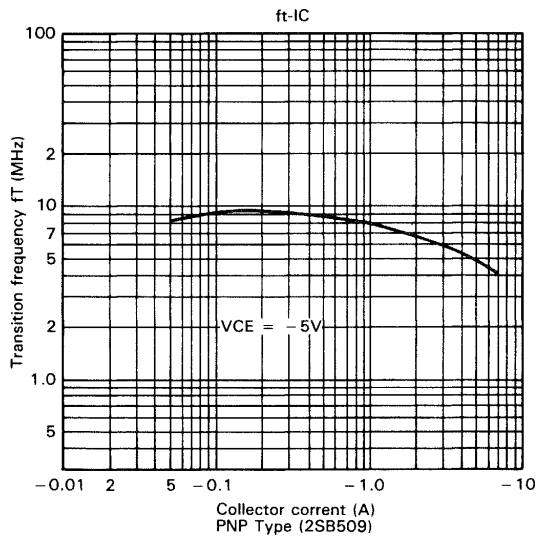


Fig. 56  $f_T-I_C$  characteristics

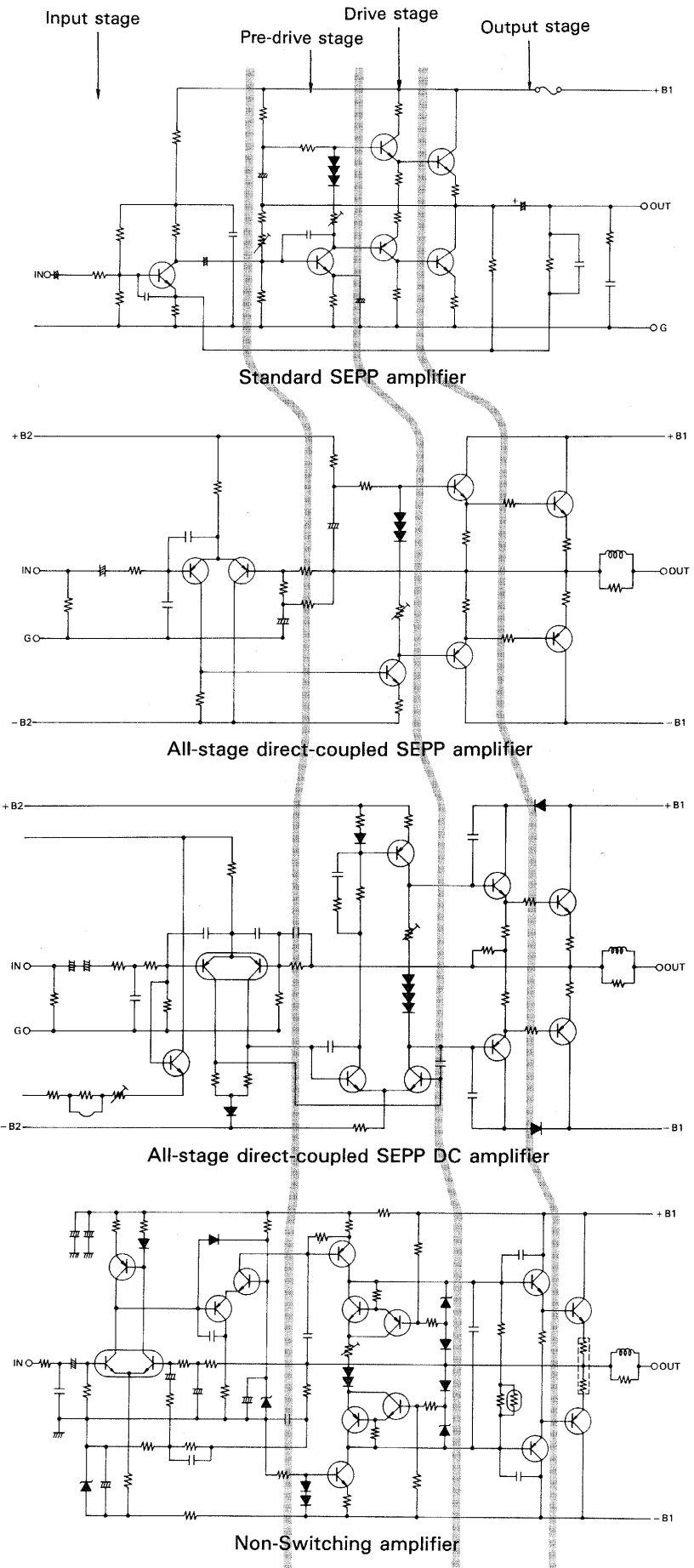


Fig 57

# II. Troubleshooting Guide

Checking circuits or components at random on complicated circuit boards is inefficient and time wasting. With an NSA in particular, replacing only one faulty component while neglecting to check others will not solve the trouble. The same trouble will reoccur, damaging the replaced component again, this is one faulty component has a close relation to many other components. Knowledge of principles and checking methods is therefore more important in the case of NSAs than for other components such as tuner, turntable or tape deck. Let's discuss the knowhow.

## 1. Typical Troubles Noted in Repair Reports

In order to perform repairs reasonably and efficiently, knowledge of how to find cause (faulty components) and effect (symptom) is essential. In principle, the causes may be as many as the number of components. The following are pie charts of problems, classified by blocks and components, based on repair reports received in the last two years.

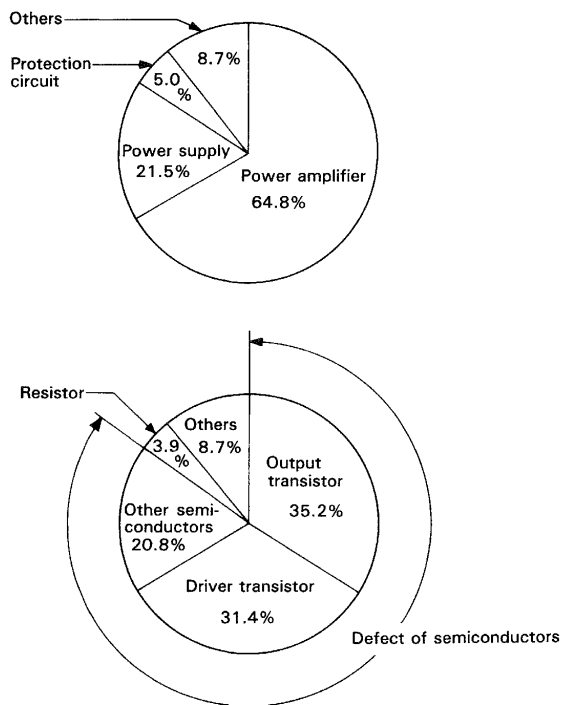


Fig. 58 Pie charts for faulty blocks and components

As seen in Fig. 58, power transistors and driver transistors in the power amplifier block are the most liable to be damaged. These charts help us to guess the parts to be checked first.

## 2. How do Troubles Occur?

### a) How are transistors damaged?

As seen above, in power amplifiers, transistors, especially power transistors, are most likely to be damaged. Power transistors may be damaged by the following: (1) Being driven with high power for a long time, (2) Short-circuit, or near short-circuit, of the load making the current in the transistor excessive, and causing heat to be generate, and/or (3) Excessive power supply voltage.

The handling power of power transistors is much higher than that of the other transistors. Heat is inevitably generated when they are driven at high power levels. To cool and protect the transistors, it is necessary to design well-ventilated amplifiers with large heat-sinks. The maximum allowable operating temperature of each transistor has been specified. Under no circumstances should the Junction Temperature ( $T_j$ ) exceed the specified value. The maximum  $T_j$  allowable for silicone transistors is between  $120^\circ$  and  $200^\circ\text{C}$ . It should be noted that the allowable collector dissipation ( $P_c$ ) will decrease when ambient temperature increases even when the  $T_j$  does not reach the specified.

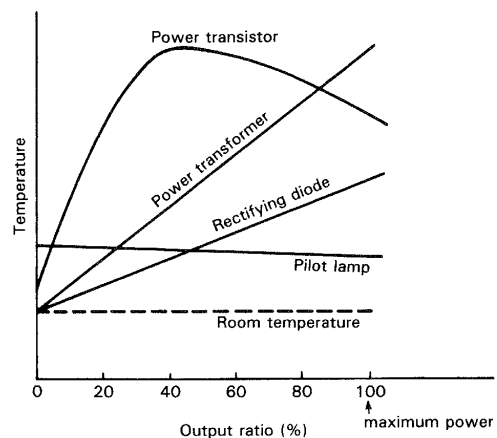
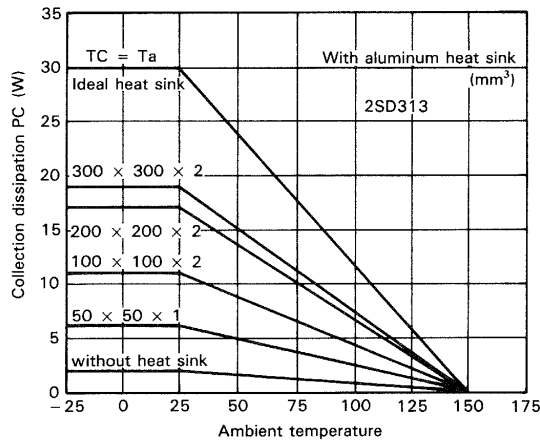
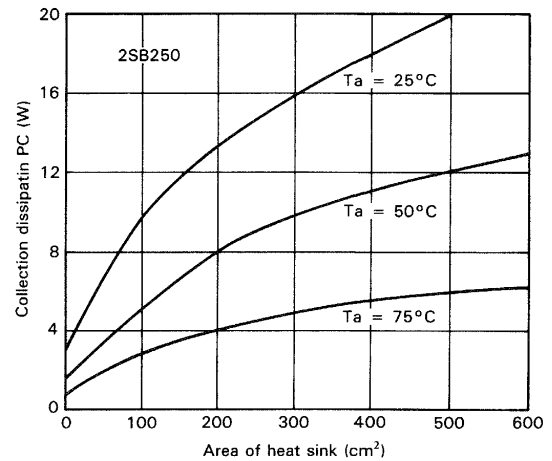


Fig. 59 Output ratio versus temperature rise

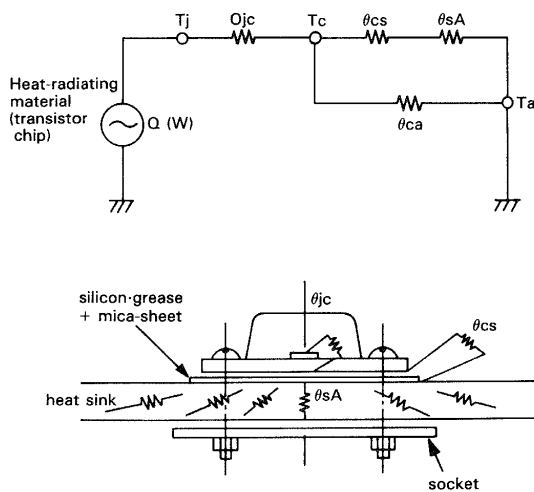


**Fig. 60 Ambient temperature versus allowable collector dissipation (Pc)**



**Fig. 61 Area of heat sink versus collector dissipation**

Thermal resistance is the resistance of a material to the conductivity of heat. The unit is ( $^{\circ}\text{C}/\text{W}$ ). The radiating system of the heat generated in the transistor from its case to the air can be expressed by an equivalent electric circuit as follows:



**Fig. 62 Thermal resistance in the radiating route**

- Q: Collector dissipation (W)
- $T_j$ : Junction temperature ( $^{\circ}\text{C}$ )
- $T_c$ : Temperature of case ( $^{\circ}\text{C}$ )
- $T_a$ : Ambient temperature ( $^{\circ}\text{C}$ )
- $\theta_{jc}$ : Thermal resistance between junction and case ( $^{\circ}\text{C}/\text{W}$ )
- $\theta_{cs}$ : Thermal resistance between case and heat sink ( $^{\circ}\text{C}/\text{W}$ )
- Generally, between silicon grease and mica sheet
- TO-3 type:  $0.4^{\circ}\text{C}/\text{W} \sim 0.5^{\circ}\text{C}/\text{W}$
- TO-220 type:  $0.7^{\circ}\text{C}/\text{W} \sim 1.0^{\circ}\text{C}/\text{W}$
- $\theta_{sA}$ : Thermal resistance of heat sink ( $^{\circ}\text{C}/\text{W}$ )
- $\theta_{ca}$ : Thermal resistance between transistor case and surrounding air ( $^{\circ}\text{C}/\text{W}$ )
- (About  $30^{\circ}\text{C}/\text{W}$ )

Fig. 62 shows the cross section of a transistor and its simplified equivalent circuit under stable state. It gives the following equation:

$$T_j - T_a \doteq Q (\theta_{jc} + \theta_{cs} + \theta_{sA})$$

Heat sinks are designed to satisfy the above equation so as to keep transistor temperature below the maximum junction temperature ( $T_j \text{ max}$ ) and to give long transistor life. Repetitive thermal expansion and contraction wears out transistors. There is no problem if a transistor is continuously operated under constant temperature. Thermal wearing of a transistor, however, is inevitable because the thermal the expansion coefficient differs depending on materials, and alternate heating and cooling of the materials by fluctuating current in the transistor wears out the junction points.

The power transistors in a class-B amplifier are also heated by the storage effect of electrons, and wear out fast when the operating frequency becomes high (20kHz — 100kHz). Refer to Fig. 63.

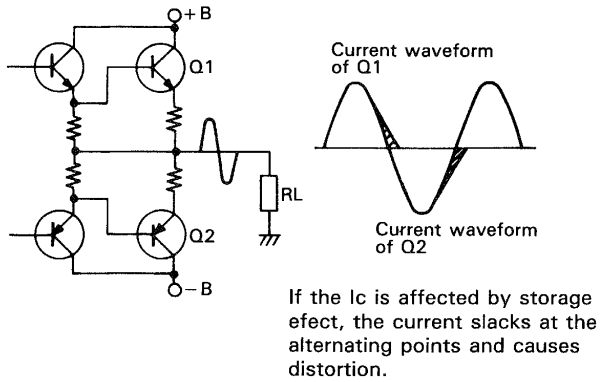


Fig. 63 Wave deformed by storage effect of electron

To obtain high performance, transistors of superior frequency characteristics are required. However, transistors which have excellent high-frequency characteristics are weak because their Area of Safety Operation (ASO) is small.

ASO has two meanings. One is the maximum allowable temperature of operation under constant conditions. This is the matter of collector dissipation. The other is the matter of Secondary Breakdown (S/B). As seen in Fig. 64, a transistor accepts a current up to several times as large as the allowable if the voltage between collector and emitter ( $V_{CE}$ ) is low and the period is short. When  $V_{CE}$  is increased, however, the current rapidly increases, and even after  $V_{CE}$  is decreased, the current further increases until it damages the transistor.

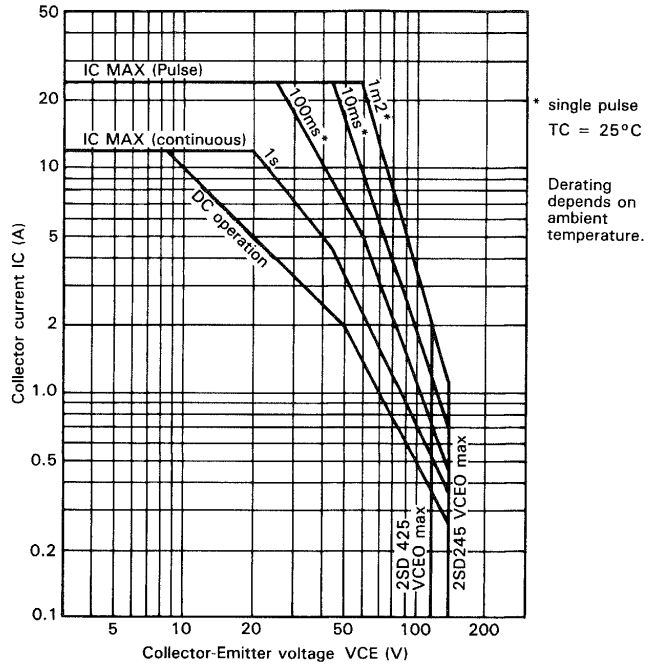


Fig. 64 ASO characteristic of power transistor

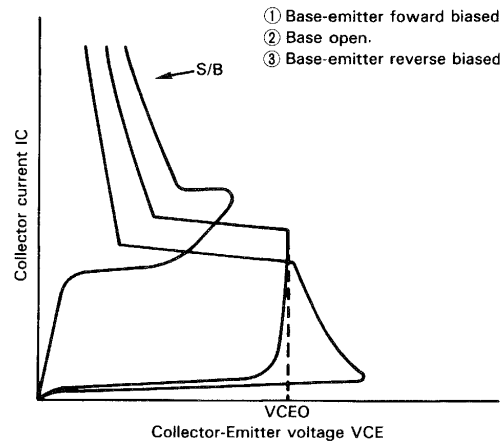


Fig. 65 Secondary breakdown of common emitter circuit

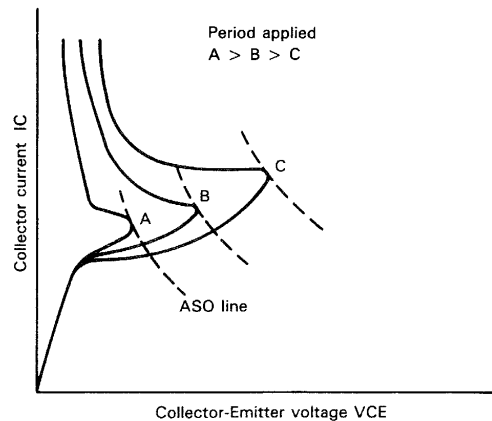


Fig. 66 Secondary breakdown point depends on the period the voltage applied.



Fig. 65 shows irreversible  $I_c$  when  $V_{CE}$  is increased and then decreased. Fig. 66 indicates that the higher the  $V_{CE}$  and the longer the driving time, the smaller the ASO. In Fig. 64, the S/B voltage decreases in proportion to the driving time. Fig. 67 shows the impedance curve of a speaker load and ASO. The area filled with slant lines is S/B area which depends on the period operated. The impedance of a speaker is the combination of resistance,

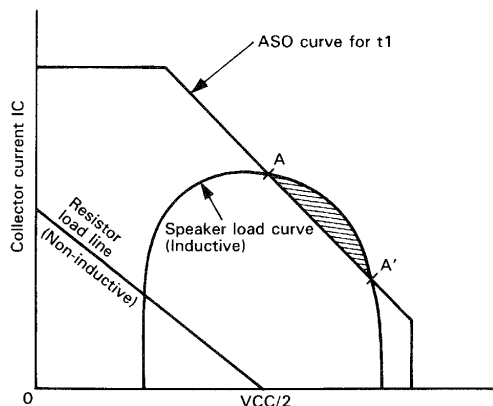


Fig. 67 Speaker load line and ASO

inductive reactance and capacitive reactance, and the speaker load curve for a transistor makes a half ellipse. When an amplifier is operated under the  $V_{CE}$  between A and A' for a period longer than  $t_1$ , the transistor(s) may be damaged by S/B. For reference, the equivalent circuit and impedance characteristic curve of typical speaker are shown below.

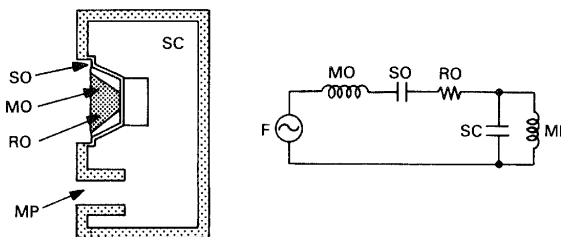


Fig. 68 Equivalent circuit of a single-cone speaker in bass-reflex type enclosure

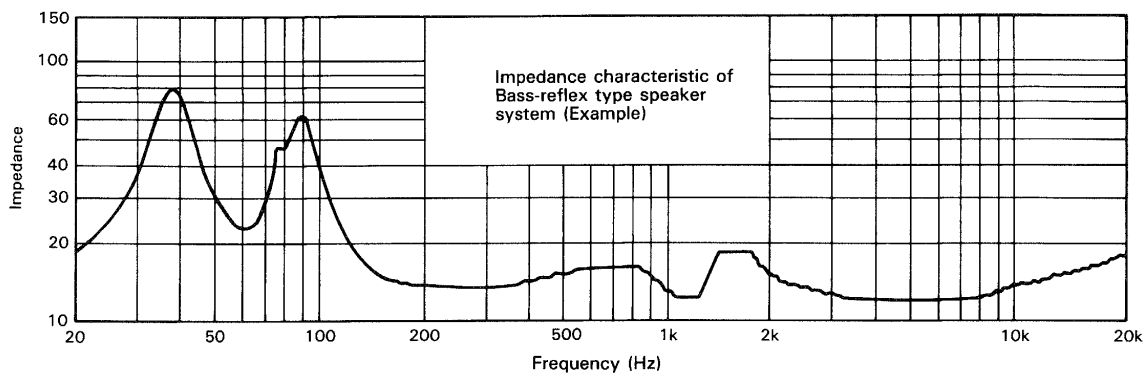


Fig. 69 Impedance characteristics of 3 way bass-reflex type speaker systems

### b) The mechanism of defects — How are amplifiers damaged?

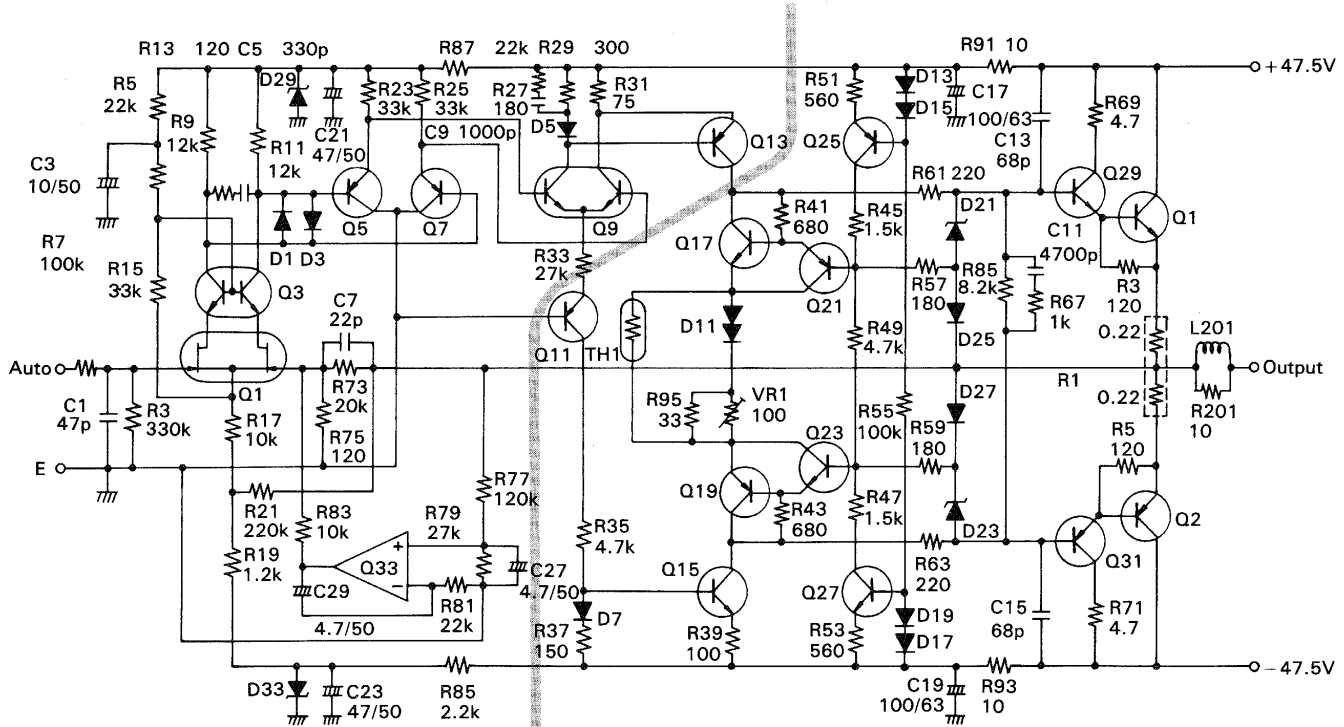
An amplifier can be repaired without finding the cause of malfunction by replacing all components such as transistors and diodes liable to be damaged. However, such repairs are a waste of money and time. To repair the amplifier efficiently, some knowledge of the principle of the amplifier is required.

Transistors are damaged by the various causes mentioned above. Other than those causes, there are incidental cases of low probability. When a power amplifier becomes defective, several components become defective at a time; in very few cases is only one component damaged.

For example, blowing a fuse is usually caused by short-

circuited power transistors. There are, however, often other causes. Further, if power transistors are short-circuited, other components are also often damaged. For example, an excessive current or voltage will blow other transistors and resistors. Here is a clue to solve the problem.

For easy understanding, a power amplifier can be divided into two areas as in Fig. 70. When a transistor in the upstream area becomes defective, it does not blow a fuse nor damage other components, but only causes DC unbalance. The trouble in the upstream area is incidental because the components in that area handle small current.



Components in this area become defective accidentally

Components in this area are damaged mainly due to external causes. Damaged components cause secondary failure.

Fig. 70 Components liable to be damaged

On the other hand, when transistors or even one of the transistors in the downstream area becomes faulty, the problem will be quite different, no matter what the cause is.

For example, if  $Q_1$  (output transistor) CE is short-circuited, the output stage will momentarily be damaged as follows.

- (1)  $Q_1$  CE is short-circuited.
- (2) Voltage on the center line becomes + B (+ 47.5V).
- (3) Voltage difference between  $Q_{31}$  base and center line increases.
- (4)  $I_{cs}$  of both  $Q_{31}$  and  $Q_2$  increase extremely. Also, current through  $D_{27}$  and  $D_{23}$  increases.
- (5)  $Q_{31}$  and  $Q_2$  are short-circuited between CE, and large current flows from + B to - B through  $Q_1$ ,  $R_1$  and  $Q_2$ .

Normally, the primary fuse will blow out here. However, if the fuse does not blow immediately, the following troubles may occur.

- (6) Voltage on the center line becomes 0V.
- (7)  $D_{27}$  is short-circuited.
- (8)  $Q_{21}$  becomes active and  $Q_{19}$  cuts off.
- (9) Voltage between collectors of  $Q_{17}$  and  $Q_{19}$  increases extremely.
- (10) Current through  $D_{21}$  and  $D_{25}$  also increases.
- (11)  $D_{21}$ ,  $D_{25}$  and  $D_{23}$  are short-circuited.
- (12)  $R_{61}$  and  $R_{63}$  burn.

The result is the same as above when  $Q_2$  is short-circuited at first. In most cases, damage is limited to the driver and output transistors short-circuited.

However, if the fuse is larger than the rated, the damaged area will be expanded as explained above.

Next, let's see what else can cause failure of the power amplifier.

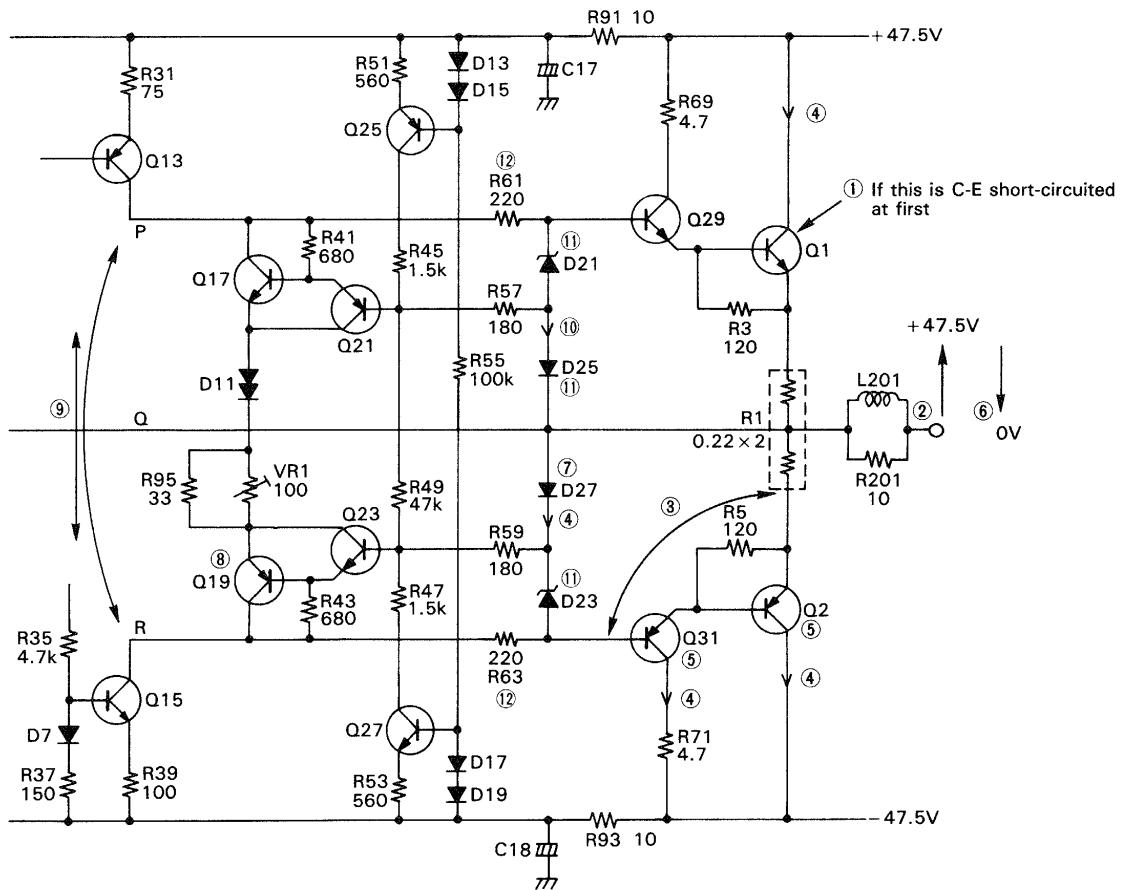


Fig. 71 Process of damage

The other causes of output transistor damage and fuse blow-out are:

a.  $D_7$  and/or  $R_{37}$ : Open

$Q_{15}$ 's  $V_{BE}$  increases, its collector current increases,  $V_{BE}$  of driver and output transistors increases, then these transistors are damaged.

b.  $Q_{15}$ : C-E Short-circuited

$Q_{13}$ 's collector current increases excessively, and the driver and output transistors are immediately damaged.

c.  $Q_{17}$ ,  $Q_{19}$  and/or  $D_{11}$ : Open

All of  $Q_{13}$ 's load current ( $Q_{15}$ 's collector current) flows through  $Q_{29}$ ,  $Q_1$ ,  $Q_2$  and  $Q_{31}$  and the four transistors are immediately damaged.

d.  $Q_{21}$  and/or  $Q_{23}$ : C-E Short-circuited

When  $Q_{21}$  E-C is short-circuited,  $Q_{17}$  completely turns off. Similarly, when  $Q_{23}$  C-E is short-circuited  $Q_{19}$  completely turns off. Therefore, the result is the same as (c).

e.  $D_{25}$  and/or  $D_{27}$ : Short-circuited

$V_{BE}$  of  $Q_{21}$  and  $Q_{23}$  increases, they completely turn on. The result is the same as (d).

f.  $Q_{25}$ ,  $Q_{27}$ ,  $R_{51}$ ,  $R_{53}$ ,  $R_{45}$  and/or  $R_{47}$ : Open

When  $Q_{25}$  opens for example,  $Q_{21}$ 's base potential becomes equal to that of  $Q_{27}$ 's collector (about  $-0.6V$ ),  $Q_{21}$ 's  $V_{BE}$  increases,  $Q_{21}$  completely turns on, producing the same results as (d). Open  $Q_{27}$ ,  $R_{51}$ ,  $R_{53}$ ,  $R_{45}$  or  $R_{47}$  causes the same result. When these are opened at the same time, no current flows through  $D_{25}$  and  $D_{27}$ , the potential of base of  $Q_{21}$  and  $Q_{23}$  becomes equal to that on the center line, and  $V_{BE}$  of the both transistors increases. The result is the same as (d).

g.  $D_{13}$ ,  $D_{15}$ ,  $D_{17}$  and/or  $D_{19}$ : Short-circuited

When  $D_{13}$  is short-circuited,  $Q_{25}$ 's  $V_{BE}$  decreases, and it turns off. The result is the same as (f).

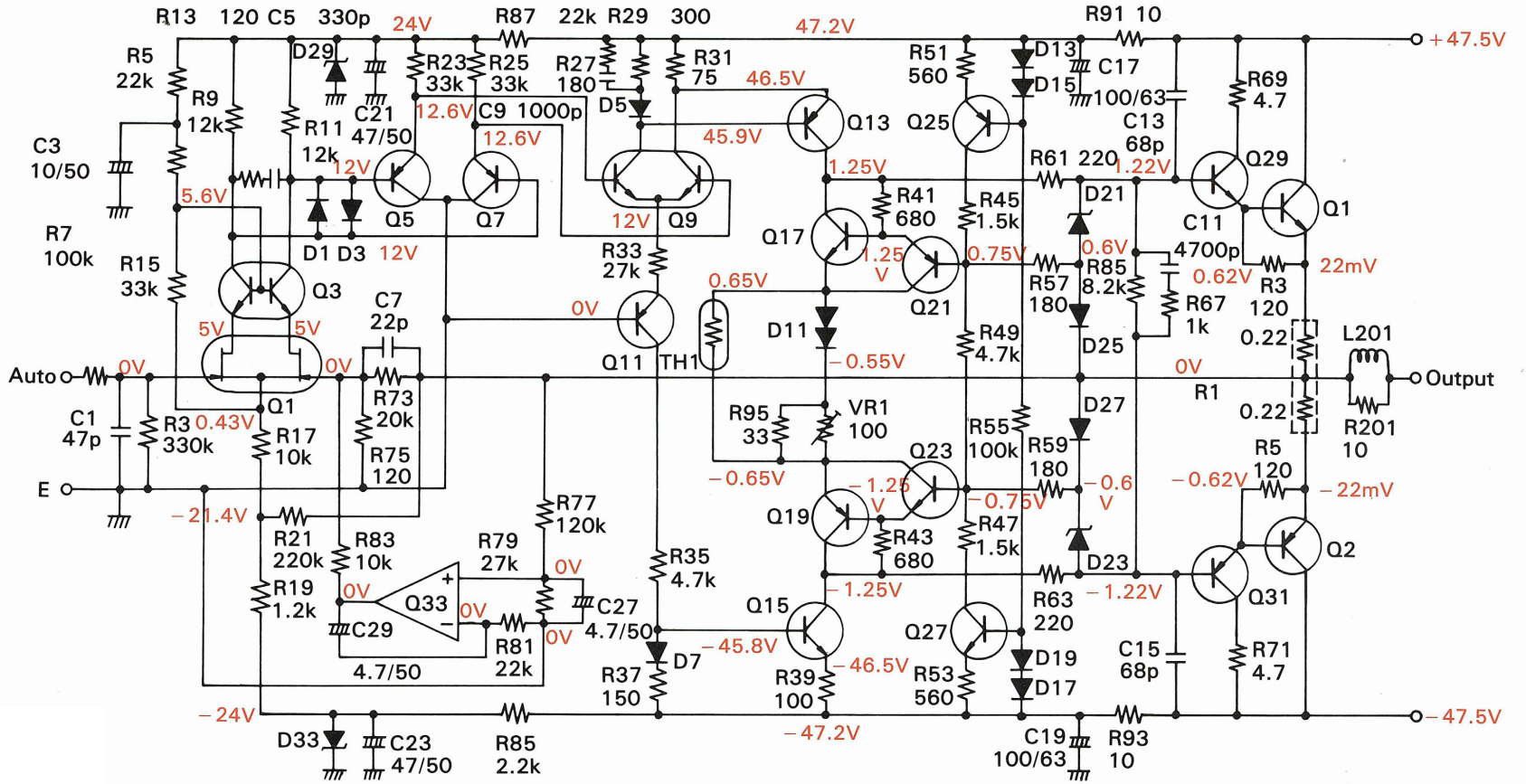
h.  $R_{41}$  and/or  $R_{43}$ : Open

No base bias is applied to  $Q_{17}$  and  $Q_{19}$ , and they turn off. The result is the same as (c).

i.  $R_{55}$ : Open

$Q_{25}$  and  $Q_{27}$  turn off,  $V_{BE}$  of  $Q_{21}$  and  $Q_{23}$  increases, and they turn on. The result is the same as (d).

Fig. 72 Voltages under normal condition (with no input)



### 3. Troubleshooting Knowhow

The means of troubleshooting power amplifiers are:

- Measuring DC voltage with Multimeter (digital voltmeter).
- Checking continuity with Multimeter.
- Applying audio signal with Audio generator, oscilloscope & mV meter.
- Confirming primary current with voltage regulator, AC voltmeter and AC ammeter.

These steps are combined to check circuits and components in accordance with the symptom and situation. Usually, most of the troubles can be solved by checking

DC potential and continuity of circuits and components with a multimeter.

Audio generator and oscilloscope are for observing symptoms, adjusting and/or confirming the normal operation. Measuring DC voltage is the method to deduce cause of trouble by comparing the measured voltage with the normal value.

#### Checking semiconductors

Continuity test with a multimeter is the easiest mean for checking semiconductors. Transistors and diodes can be checked as follows:

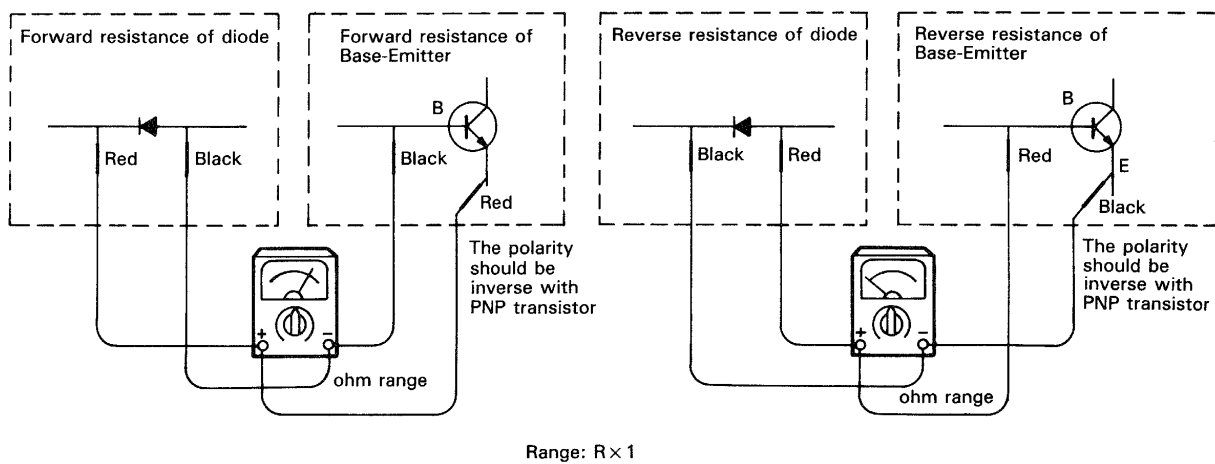


Fig. 73 Continuity test of transistors and diodes

In Fig. 73, the forward resistance reading of a diode or a transistor is usually tens of ohms depending on the sensitivity and internal resistance of the multimeter. If it is shorted-circuited, it will be  $0\Omega$ . If it is open, it will be infinite. In the reverse direction, the resistance will be infinite. (Fig. 73 shows the values measured when the components are separated from the circuit.)

A diode assembled in a circuit can be checked by turning power on and measuring the voltage across it. If it is normal, the reading is  $0.6V$ . If it is open, far more than  $0.6V$ , and if it is short-circuited,  $0V$ . A transistor in a circuit

can be checked in the same way. Turn the power on and measure the voltage between base and emitter ( $V_{BE}$ ). If it is ON and working normally,  $V_{BE}$  is  $0.6V$ .

Unless short-circuited, varistors which have been separated from the circuit are hard to check with a low sensitivity multimeter which has one or two  $1.5V$ -batteries. A high sensitivity multimeter with a  $9V$  battery, however, will do. A varistor in a circuit can be checked by measuring voltage across it while power is ON. The voltage depends on the varistor. (See Fig. 75)

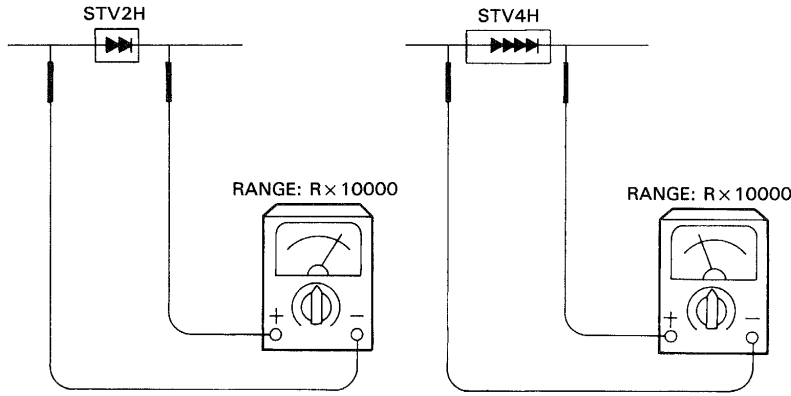
**Applying audio signal**

Applying audio signal (after the faulty components have been replaced) is normally performed to confirm whether the amplifier has been properly repaired.

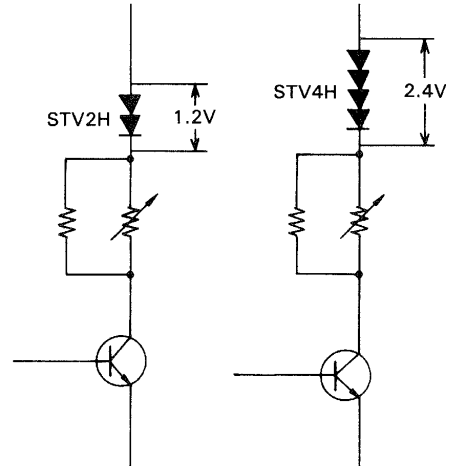
**Checking primary current**

Checking primary current is a very effective way of avoiding further damage when confirming defect before repairing, and when checking the amplifiers's condition after faulty components have been replaced.

Refer to page 40 for details.



**Fig. 74 Checking varistor (1)**



**Fig. 75 Checking varistor (2)**

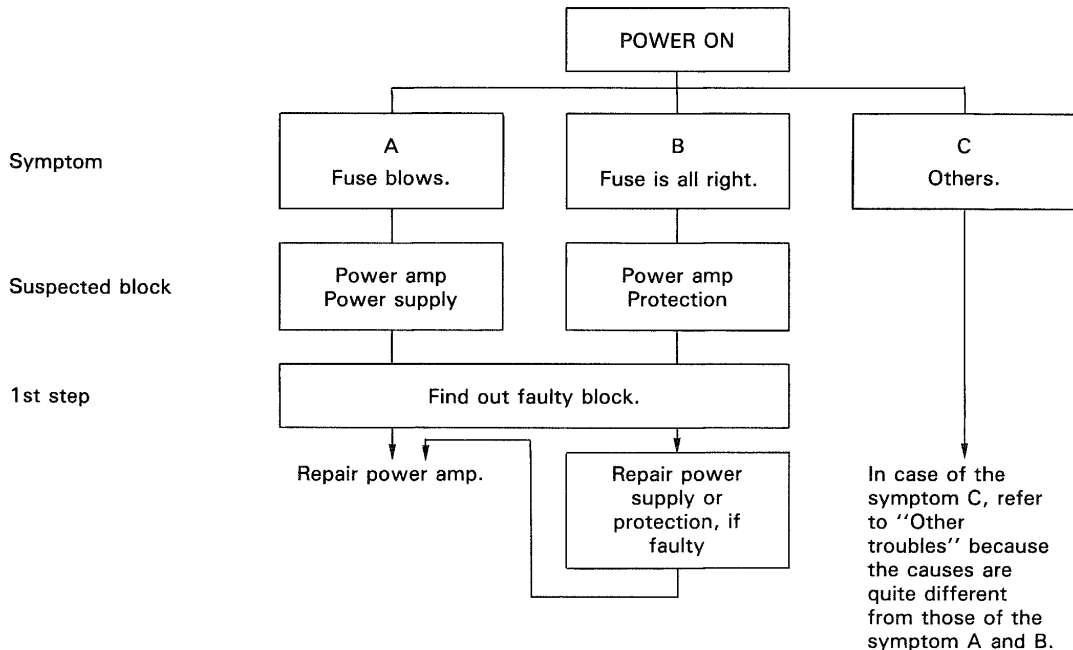
**Diagnosis and points to be checked**

Regardless of amplifier or other kinds of equipment, it is always necessary to confirm the defect and deduce the cause from the condition of the defect.

One of the reasons NSAs are difficult to repair is that there are MANY POSSIBLE CAUSES FOR A FEW SYMPTOMS, meaning that a large number of com-

ponents must be checked.

Therefore, to repair an NSA efficiently in a short period of time, it is important to troubleshoot in a particular order, that is, to find the faulty block first, then the faulty components in the faulty block as shown in Fig. 76.



**Fig. 76 Confirmation of defect**

It must be noted that the same symptom may appear when other block(s), such as power supply or protection

circuit, is faulty. Fig. 77 and Fig. 78 show examples.

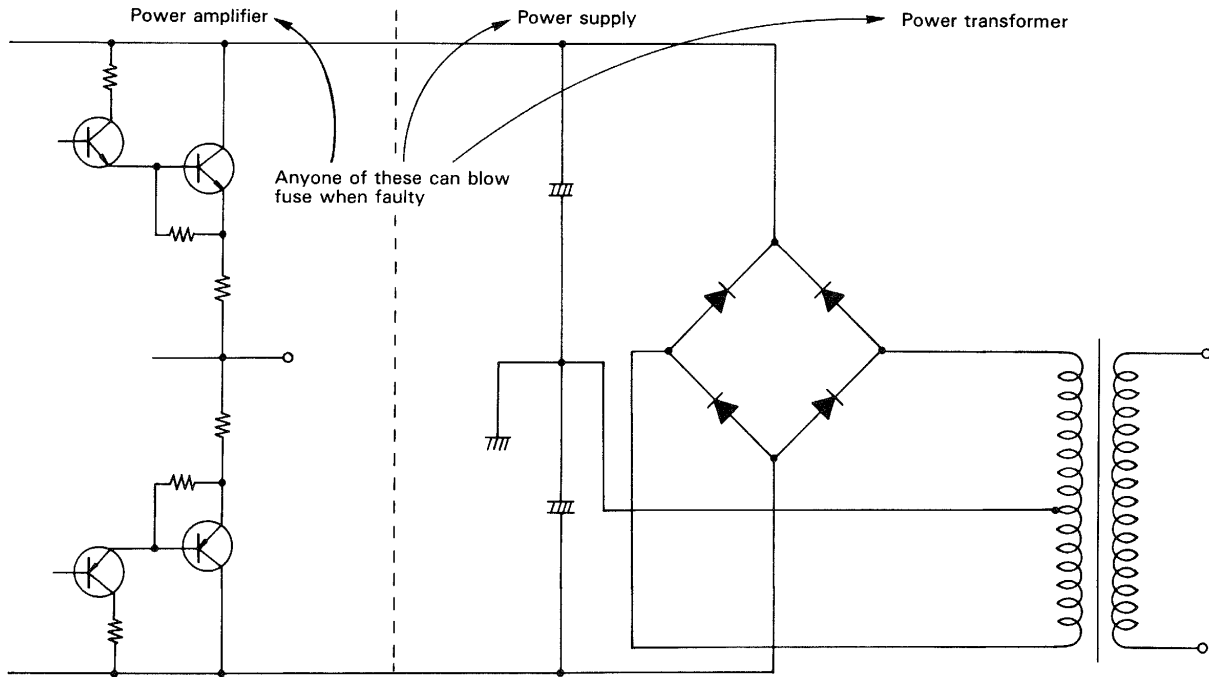


Fig. 77 Causes of blowing power fuse

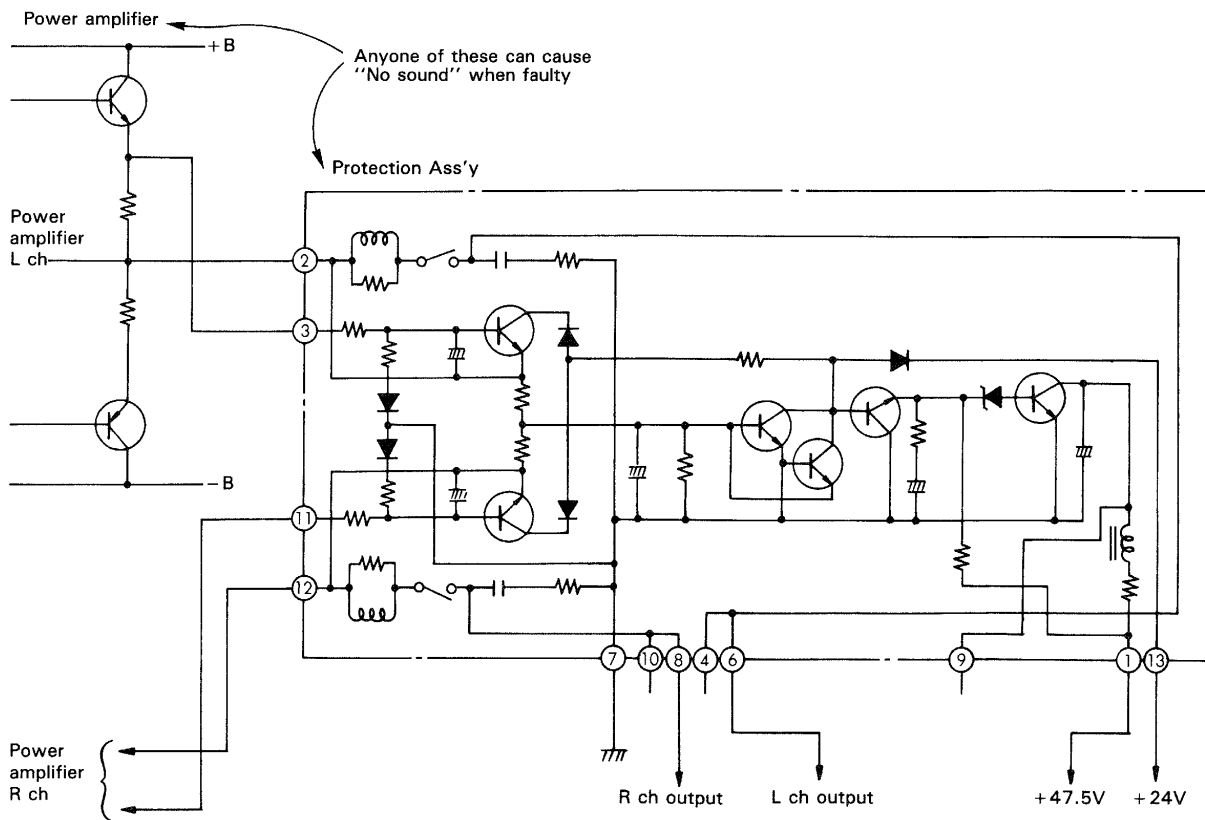


Fig. 78 Causes of no sound

To find out which block is faulty, check the continuity between the collectors of the output transistors (+ B and - B) as shown in Fig. 79 ①.

If the resistance reading is  $0\Omega$  or nearly  $0\Omega$ , disconnect the + B and - B lines at the X-marked points and check the continuity again.

If the reading is not  $0\Omega$ , the amplifier block is OK, and the power supply block is faulty.

If the reading is still  $0\Omega$ , the power amplifier block is faulty. In this case, there is a possibility that the power supply block is also faulty. Therefore, ② and ③ must also be checked, and if the readings are  $0\Omega$ , then check the continuity of the individual components in power supply block.

The faulty power supply block must be repaired before starting to troubleshoot the power amplifier.

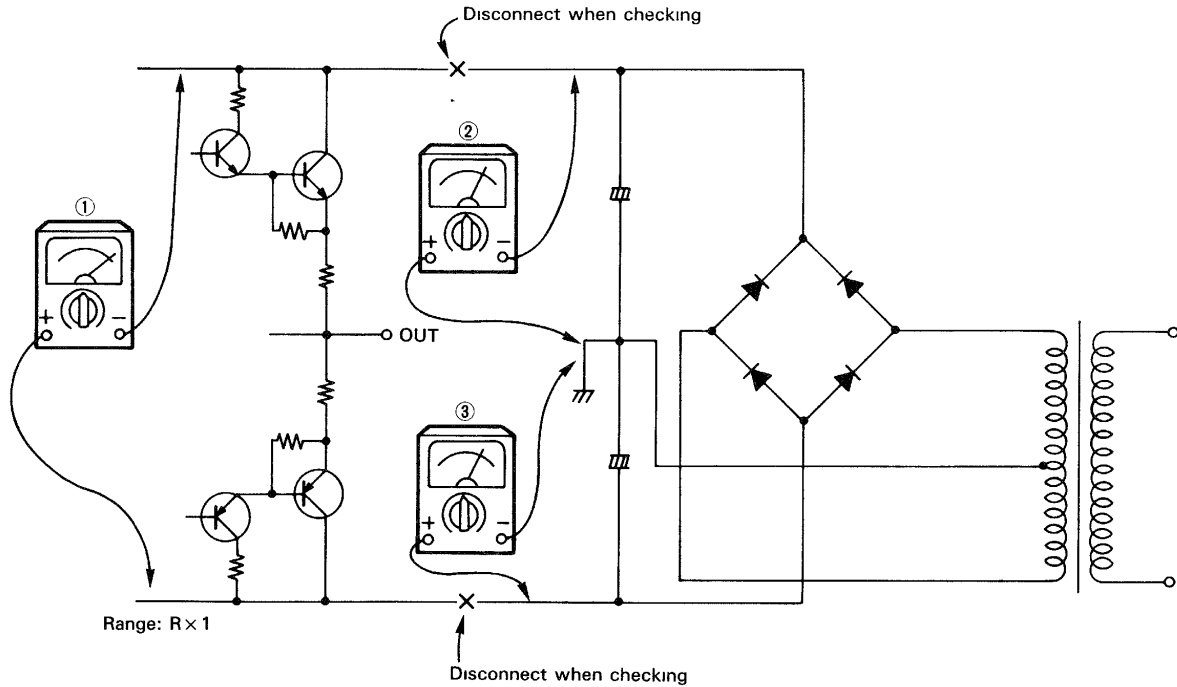


Fig. 79 Finding faulty block — Primary fuse blows out.

In case no sound is produced even when the fuse does not blow out, it is necessary to find out which block is faulty ... power amplifier or protection circuit.

First, check the voltages of + B (+47.5V), - B (-47.5V) and pin 13 of the protection assembly (+24V).

(If not OK, the power supply block is faulty and must

be repaired first, of course.)

If these are all OK, then check the DC voltage on the center line of the power amplifier (both channels).

The voltage on the center line must be within  $\pm 30\text{mV}$ . the faulty block can be found as follows:



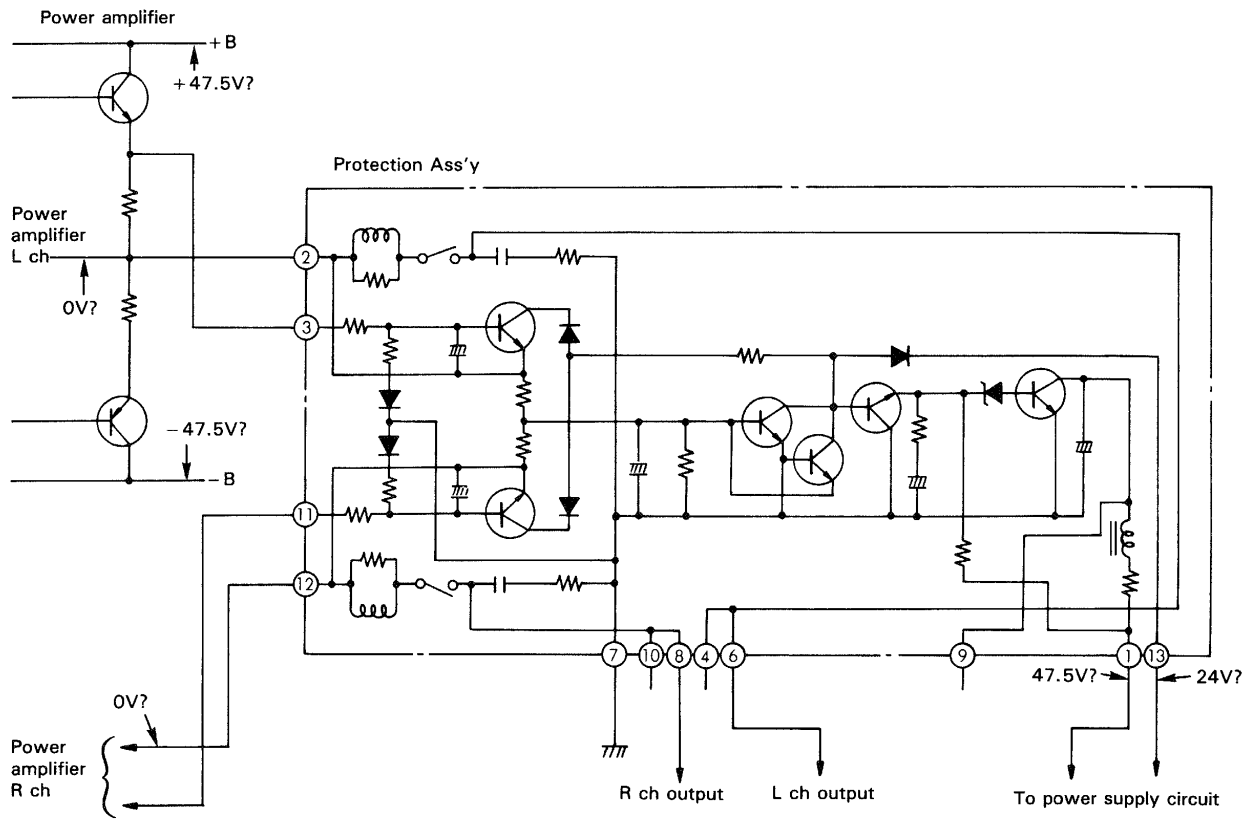


Fig. 80 Finding faulty block – No sound

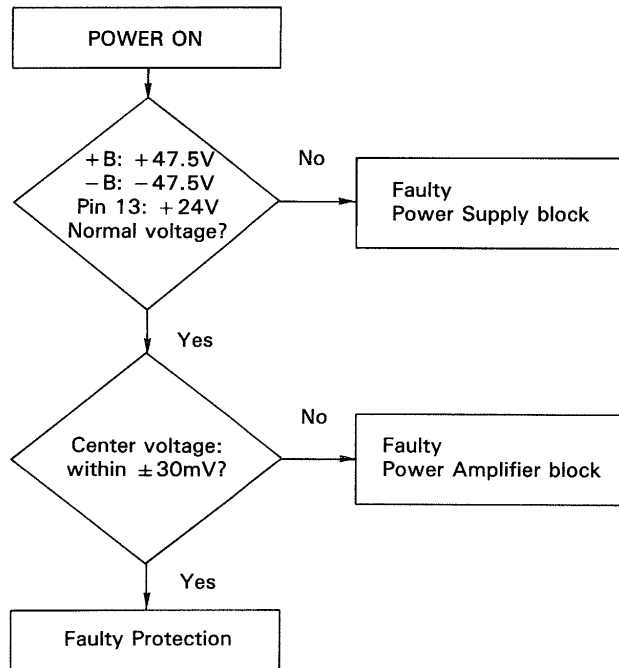


Fig. 81 Finding faulty block

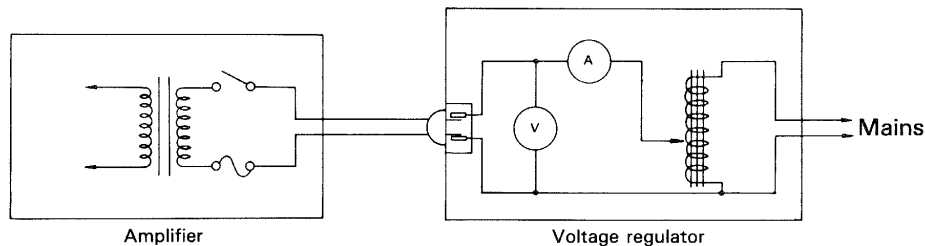
### Confirming symptom with a Voltage Regulator

As mentioned, confirming the symptom is essential before starting repairs. Fuse blowing is the trouble that requires special attention among other kinds of troubles. In some cases, normal components may be damaged before the fuse blows out when the rated voltage is applied directly from the mains line because fuses do not always have exact ratings. In such cases, adapt a voltage regulator between the mains line and the faulty unit as shown in Fig. 82-a.

First, set the regulator output at 0V. Power on. Gradually increase the voltage watching the current and voltage carefully.

Depending on the defect, the current may exceed the rated

value before the voltage reaches 10% of the rated voltage. If so, it automatically means that there is a defect in the amplifier that may damage other normal components. Immediately turn the power off or turn the voltage control down to 0V and perform a continuity test to check which block or circuit is short-circuited. If the current does not exceed the rated, turn the regulator control up to the rated voltage and start checking the unit. When a power amplifier malfunctions, several components are often damaged at a time. If even one of the faulty components is left unreplaced, the same trouble will reoccur and damage other normal components. This kind of trouble can be prevented by using a voltage regulator.



**Fig. 82-a** Detecting excessive current with a voltage regulator

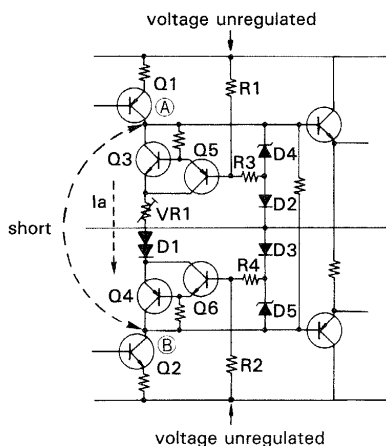
In most cases, the primary current increases gradually in proportion to its voltage. But, it should be noted that there are some exceptions. In the case of amplifiers such as A-5, A-6, SA-940, etc. which have a NSA bias circuit with high value R1 and R2 (more than 35kΩ, Fig. 82-b) which power is fed from non-regulated power source, the current increases rapidly first (3 or 4A at 10V), then drops suddenly, and finally increases gradually as the voltage increases as shown in Fig. 82-c.

The reason for this is as follows:

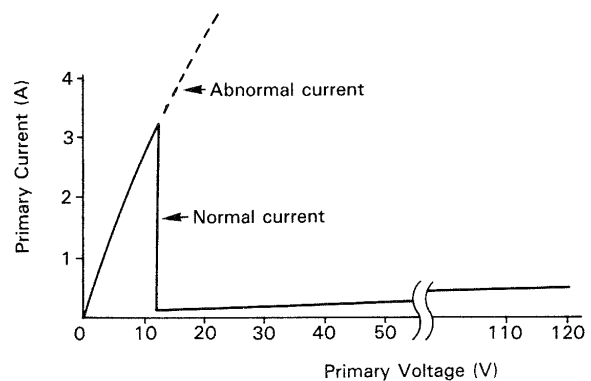
Even when the supply voltage is low, Q1 and Q2 turn on to flow the current  $I_a$  through Q3—VR1—D1—Q4. But at this time the  $V_{BE}$  of Q5 and Q6 is increased by the R1 and R2 of high resistance, and Q5 and Q6 turn on com-

pletely. Q3 and Q4 turn off and block the  $I_a$ . Then the  $I_a$  is forced to go to the power transistors. The current in the power transistors increases and makes the primary current increase. When the voltage is further increased, the current flowing through R3, D2, D3 and R4 increases, then the  $V_{BE}$  of Q5 and Q6 decreases. Q5 and Q6 turn off. Q3 and Q4 turn on and then the current becomes normal. (Fig. 82-c)

So, when checking these models, check Q3, Q4, Q5 and Q6, and D1, D2 and D3, and VR1 first. If they are all right, make a short circuit between (A) and (B) and increase the primary voltage. Then the current will increase gradually. If the current still keeps increasing, the trouble may be in the transformer or power transistors.



**Fig. 82-b** NSA bias circuit



**Fig. 82-c** Primary voltage vs primary current

# 4. Troubleshooting Power Amplifier

Troubleshooting the power amplifier is started after power supply and protection circuit are confirmed to be OK. In the case of the NSA, the causes of troubles tend to concentrate in some particular areas, depending on the kind of defect. For example, in the case of the defect, "The fuse blows out.", the causes exist in the predrive and the following stages while in the case of the defect, "No sound but the fuse does not blow", the causes exist

in the input and the next two stages theoretically and practically as shown in Fig. 83. Therefore, to save time, it is important to narrow down the area to be checked by confirming the symptom as mentioned above. It must be noted that several components have been damaged in the case of the defect, "The fuse blows out."

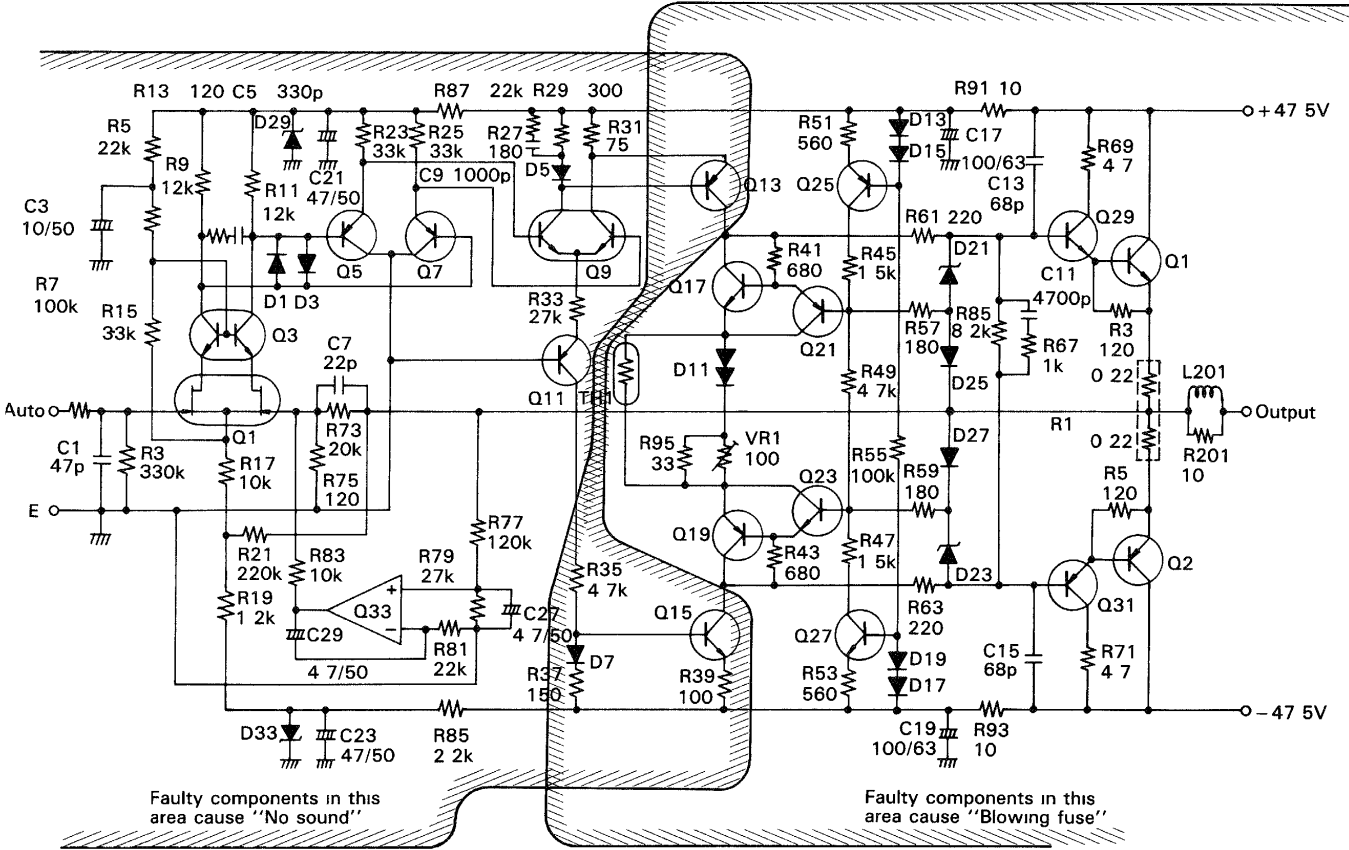


Fig. 83 Suspected area for each trouble

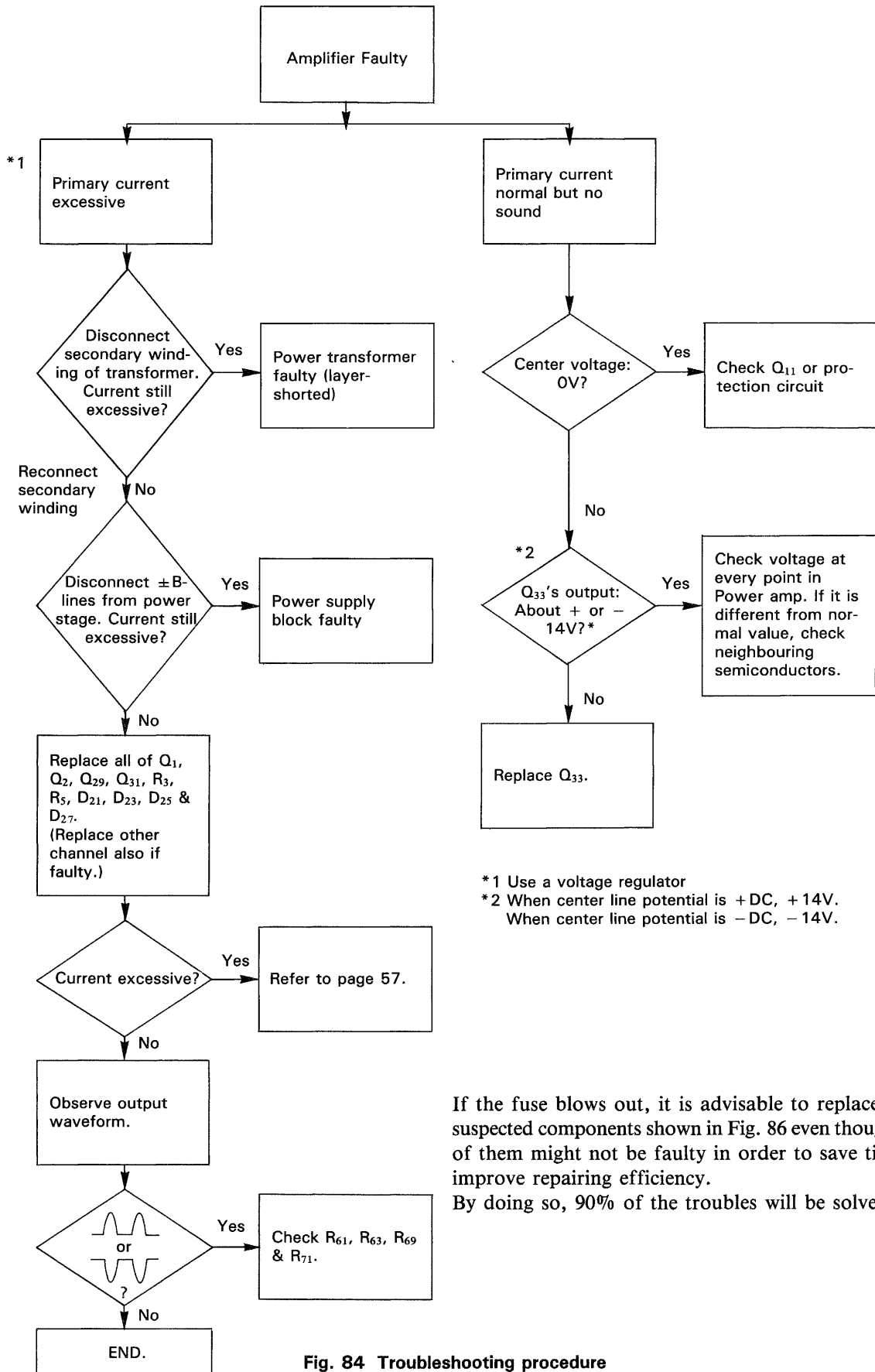
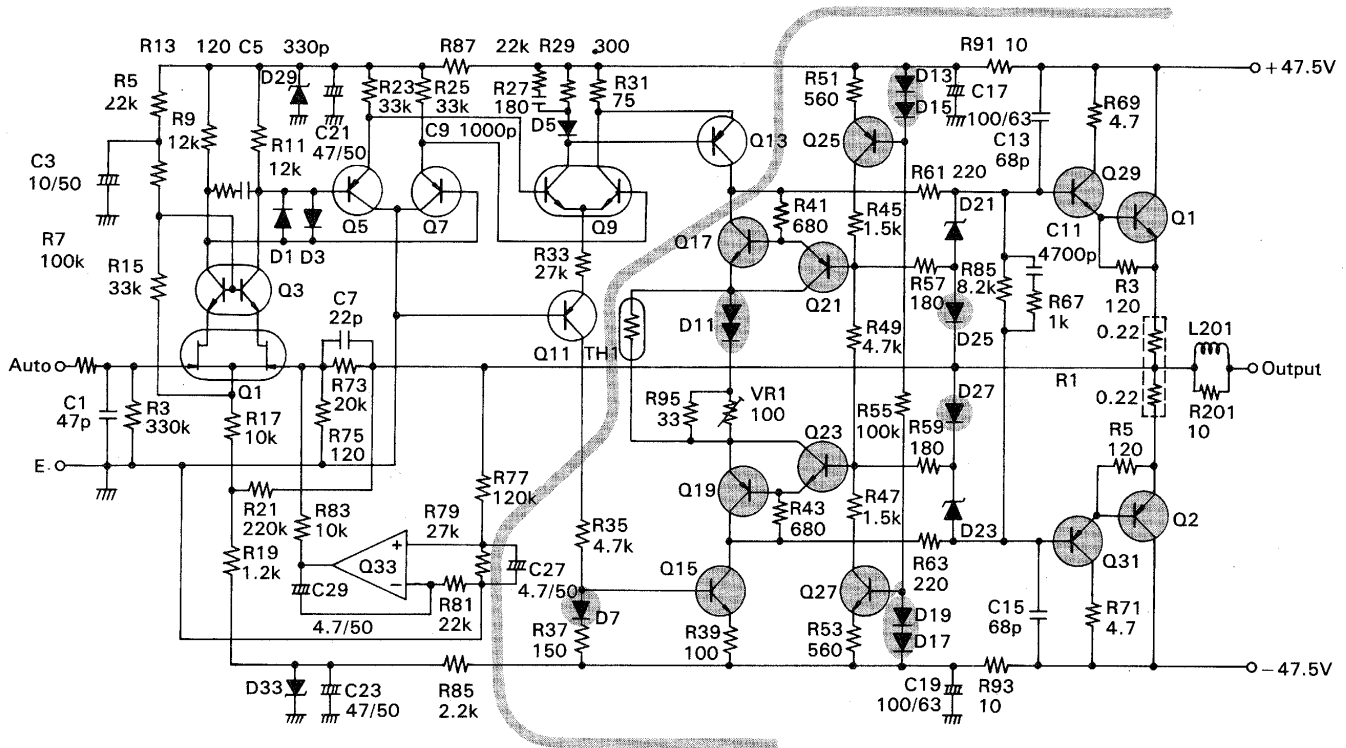


Fig. 84 Troubleshooting procedure

**a) Primary fuse blows out.**

Possible causes;

Output stage	Both transistors short-circuited.
Driver stage	C-E shorted on both channels.
Pre-driver stage	Q <sub>15</sub> and C-E Shorted.
Biasing circuit	Q <sub>17</sub> and/or Q <sub>19</sub> Opened
	Q <sub>21</sub> and/or Q <sub>23</sub> C-E Opened
	Q <sub>25</sub> and Q <sub>27</sub> C-E Opened
	D <sub>25</sub> and D <sub>27</sub> Shorted
	D <sub>13</sub> , D <sub>15</sub> , D <sub>17</sub> and/D <sub>9</sub> Shorted



**Fig. 85 Suspected components when fuse blows**

In the event that the fuse blows out right after power is turned on, this is obviously caused by excessive current in the output transistors. It must be noted that there are two cases for the excessive current. One is the C-E short-circuit of the driver or output transistors. The another is the defect(s) of the component(s) in the upstream which has caused the C-E short-circuit of these transistors.

### Steps

As mentioned, although the driver and power transistors are most likely to be damaged, do not turn the power on right after replacing them. They could be the secondary cause. Unless all other faulty components are replaced, the same trouble will occur again. Therefore, check all other suspected components shown in Fig. 86 in the way shown in Fig. 73 and replace all faulty ones.

Another thing to be noted is that there might be secondary damage, namely, some other components might have been damaged by the excessive current. If such components remain unreplaced, they will cause further trouble such as DC offset, no amplification, distortion, and blowing of fuse.

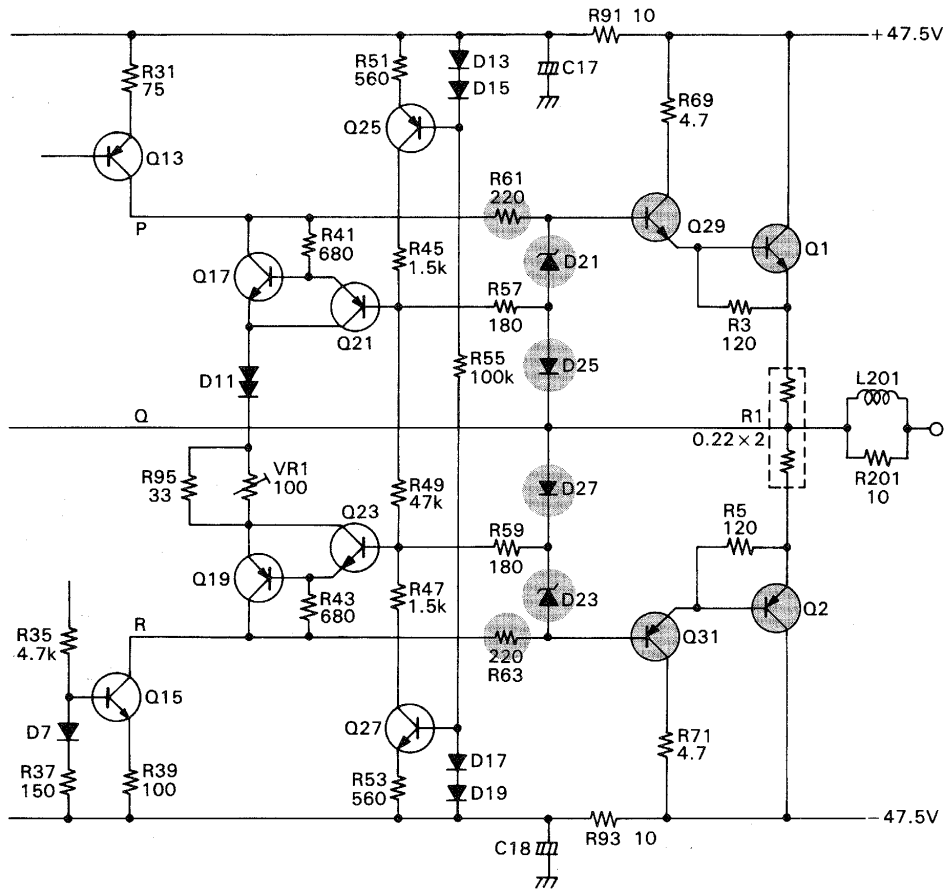


Fig. 86 Components liable to be damaged

### Inspection after replacing components

After replacing faulty components, check and confirm the potential at the points indicated in the circuit diagram, adjust the idle current, referring to the service manual, and confirm that the heat sinks and power transformer

do not get hot. Then, connect a load to the amplifier and confirm that no distortion nor oscillation appears at the rated output.

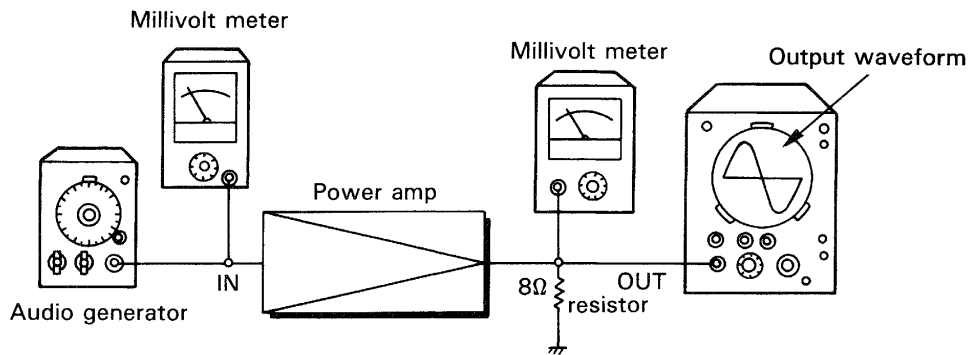


Fig. 87 Final check after repairing

**Caution** — After repairing, inspection is required because the same trouble will occur again if the primary cause is not eliminated. For example, if the primary cause is “excessive idle current”, the power transistors may blow after use for a certain while unless the idle current is adjusted properly. Referring to the service manual, confirm the following points after repairing to make the job perfect.

1) Idle current. The current should be as prescribed and constant for many hours, after warming up for more than 20 minutes without signal input.

2) Center line voltage. The voltage should be as prescribed and constant for many hours, after warming up for more than 20 minutes without signal input.

3) Operation test

Input: Music (FM or TAPE)

Load: 4—8Ω resistor (4Ω preferable)

Output level: Average power should be 1/10 of the rated.

Heat sinks and power transformer should not get too hot.

**b) Fuse is all right, but no sound.**

Possible causes:

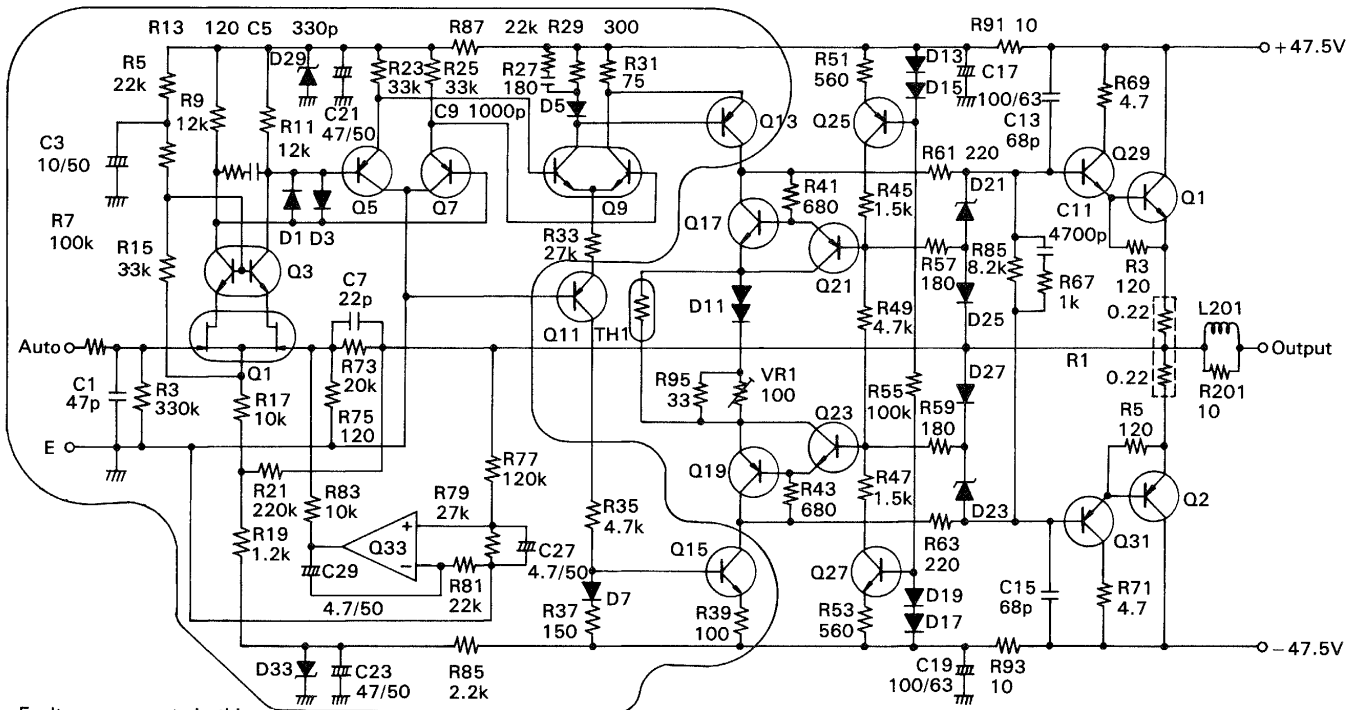
- i) DC offset voltage appears on the center line, protection circuit works and protection relay stays off.
- ii) Although DC offset voltage on the center line is 0V, amplification becomes 0 because of faulty component(s).

Start troubleshooting by measuring the DC offset on the center line. In most cases when DC offset voltage appears, the voltage becomes extreme + B or - B and intermediate voltage rarely appears.

Suspected components:

In this case, unlike in the case of blowing fuse, one of the differential amplifiers from input to pre-driver stage might be out of balance. Next to it, surrounding components such as D<sub>1</sub>, D<sub>3</sub>, D<sub>5</sub>, D<sub>29</sub> and D<sub>33</sub> and those in feedback circuit such as Q<sub>33</sub> might be damaged.

In NSA, like in other types of amplifiers, the fuse blows out when the circuits after pre-driver become defective. If the offset voltage appears and the fuse does not blow out, the components in the shaded area of Fig. 88 are to be suspected.



Faulty components in this area cause "No sound"

**Fig. 88 Suspected components in the case when sound is dead and fuse is all right**

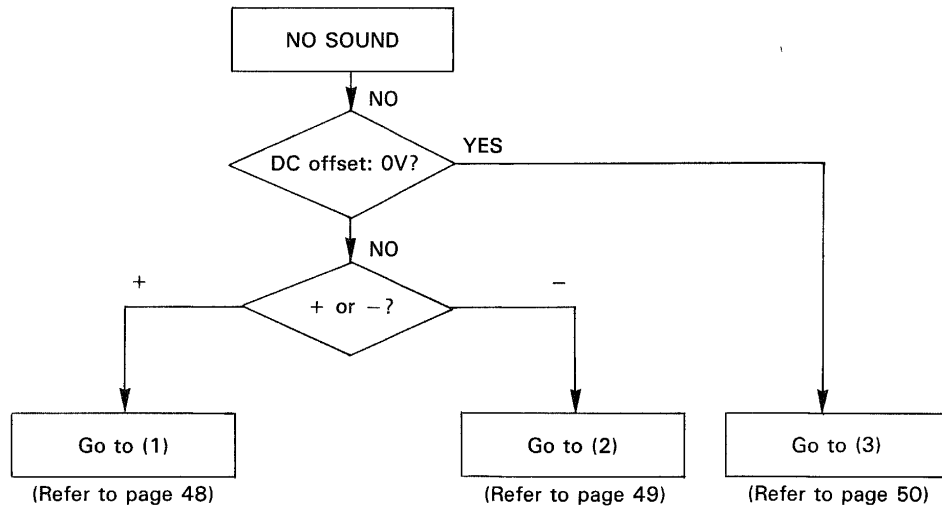


**Steps**

(1) Since diagnosis of this fault is performed mainly by checking voltages on the various points in the circuit, the DC-supply voltages must be first confirmed to be normal.

Check and confirm the voltages on the DC supply lines to the input stage (+ 24V at point P, - 24V at point n), to Q<sub>33</sub> (+ 15V, - 15V), as well as + B (47V) and - B (- 47V).

(2) Then measure the DC voltage on the center line. The next step to be performed depends on the value or polarity (Refer to Fig. 89).



**Fig. 89 Troubleshooting flowchart**

(1) When DC offset voltage is positive:

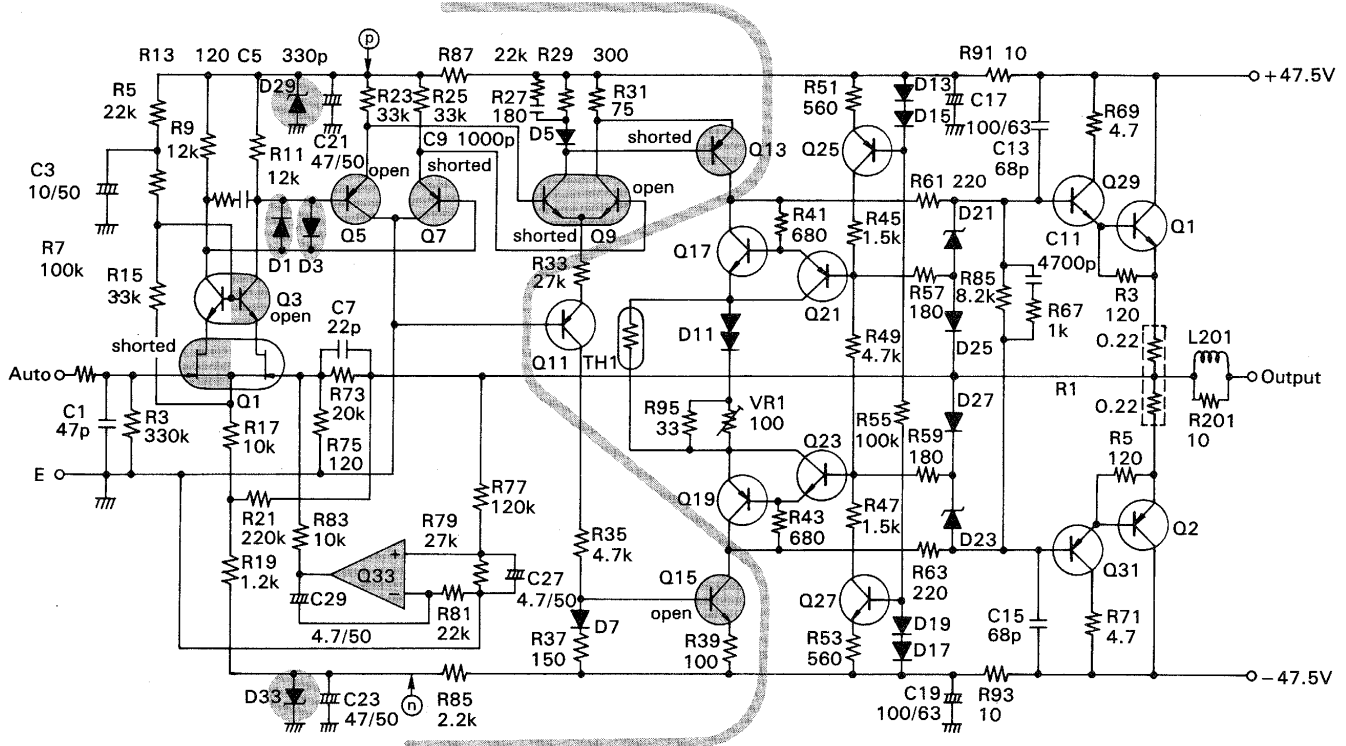
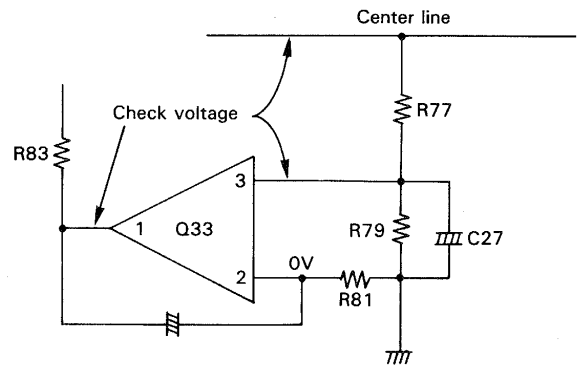


Fig. 90 Suspected components in the case DC offset voltage is positive.

Fig. 90 shows the suspected components in the case DC offset voltage is positive. Some transistors may look as if they are faulty under certain conditions. For example, when Q<sub>33</sub> is faulty, DC offset voltage appears even if other transistors are all right. DC offset voltage also appears when D<sub>1</sub> and D<sub>3</sub> are short-circuited. Therefore, check these components. In most cases, diodes should be removed when being checked. Check Q<sub>33</sub> as shown in Fig. 91.

After confirming D<sub>1</sub>, D<sub>3</sub> and Q<sub>33</sub> to be normal, check the components shown in Fig. 90 one by one. To check if a transistor is short-circuited, turn power off and check the continuity between collector and emitter with a multimeter. To check if it is open, turn the power on and measure voltage at collector, base and emitter.



When Q<sub>33</sub> is normal

Voltage on center line	Input (Pin 3)	Output (Pin 1)
+	+	+14V
0	0	0
-	-	-14V

Fig. 91 Checking Q<sub>33</sub>.

(2) When DC offset voltage is negative;

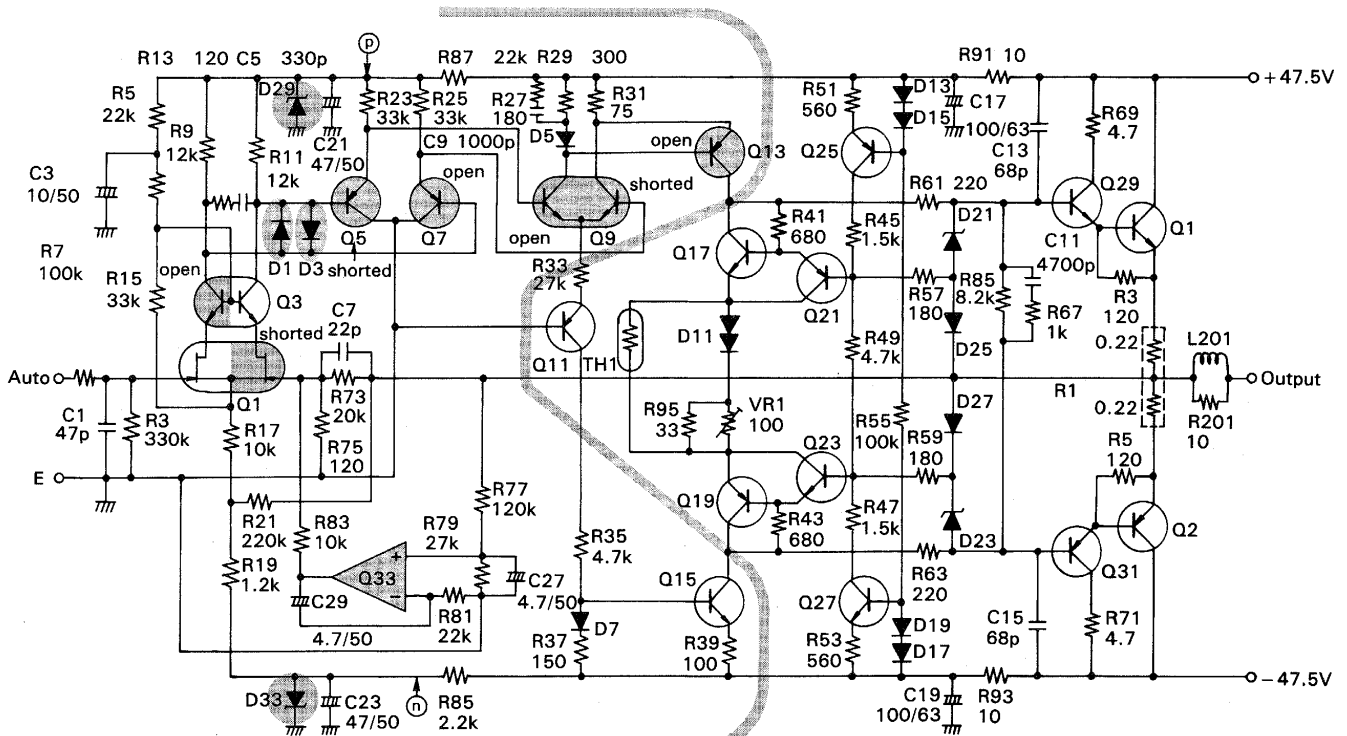


Fig. 92 Suspected components in case DC offset voltage is negative

Fig. 92 shows the suspected components when DC offset voltage is negative. Basic troubleshooting is the same as (1). First, check if D<sub>1</sub>, D<sub>3</sub> and Q<sub>33</sub> are faulty. If they are all right, check the suspected components shown in Fig. 92.

- (3) No sound although the voltage on the center line is almost 0V and protection relay turns on.

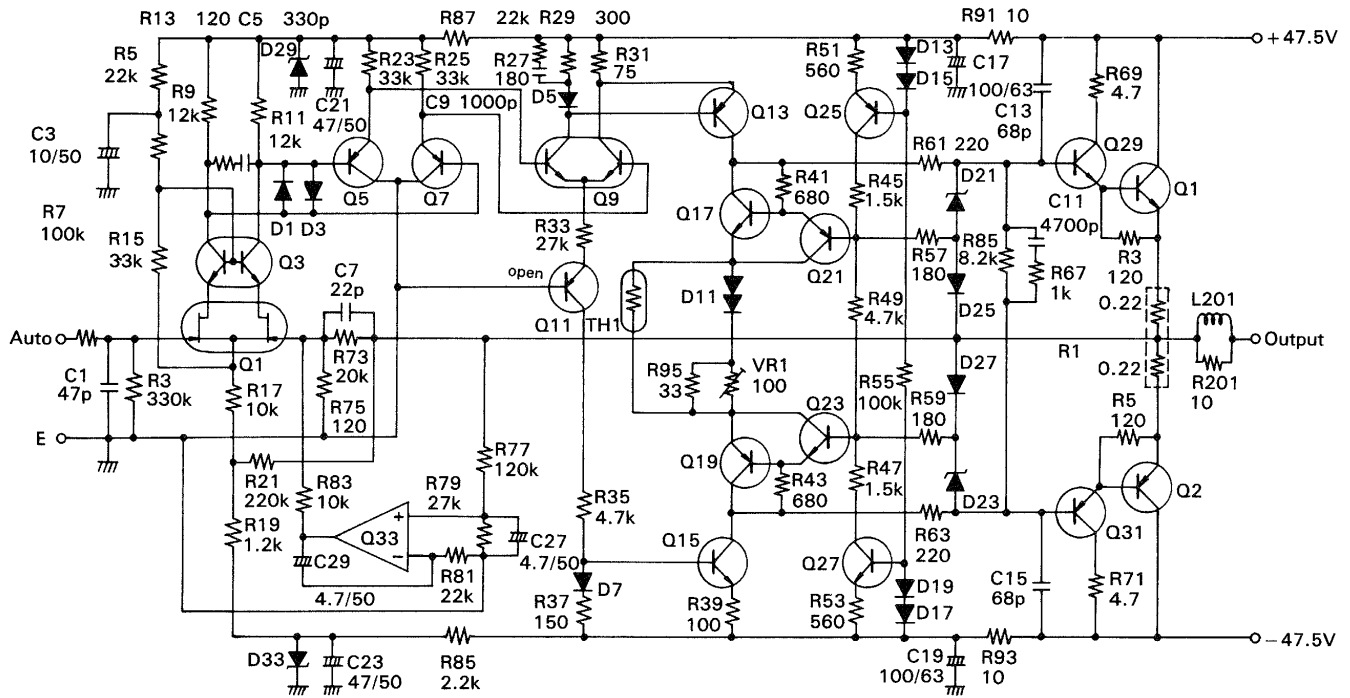


Fig. 93 Suspected components of "No sound although Protection Relay turns on."

The cause of this trouble is Q<sub>11</sub> C-E open as shown in Fig. 93.

The reason is;

Q<sub>9</sub>'s emitter current stops. Voltage at both collectors of Q<sub>9</sub> become +B. Q<sub>13</sub>'s bias voltage becomes 0V. Q<sub>13</sub> goes

off. Q<sub>15</sub> is also off without having bias current from Q<sub>11</sub>. The center line voltage becomes nearly 0V. No sound can be heard because amplifying transistors are all inactive. To check if Q<sub>11</sub> is open, measure V<sub>CE</sub>.

In case of A-9

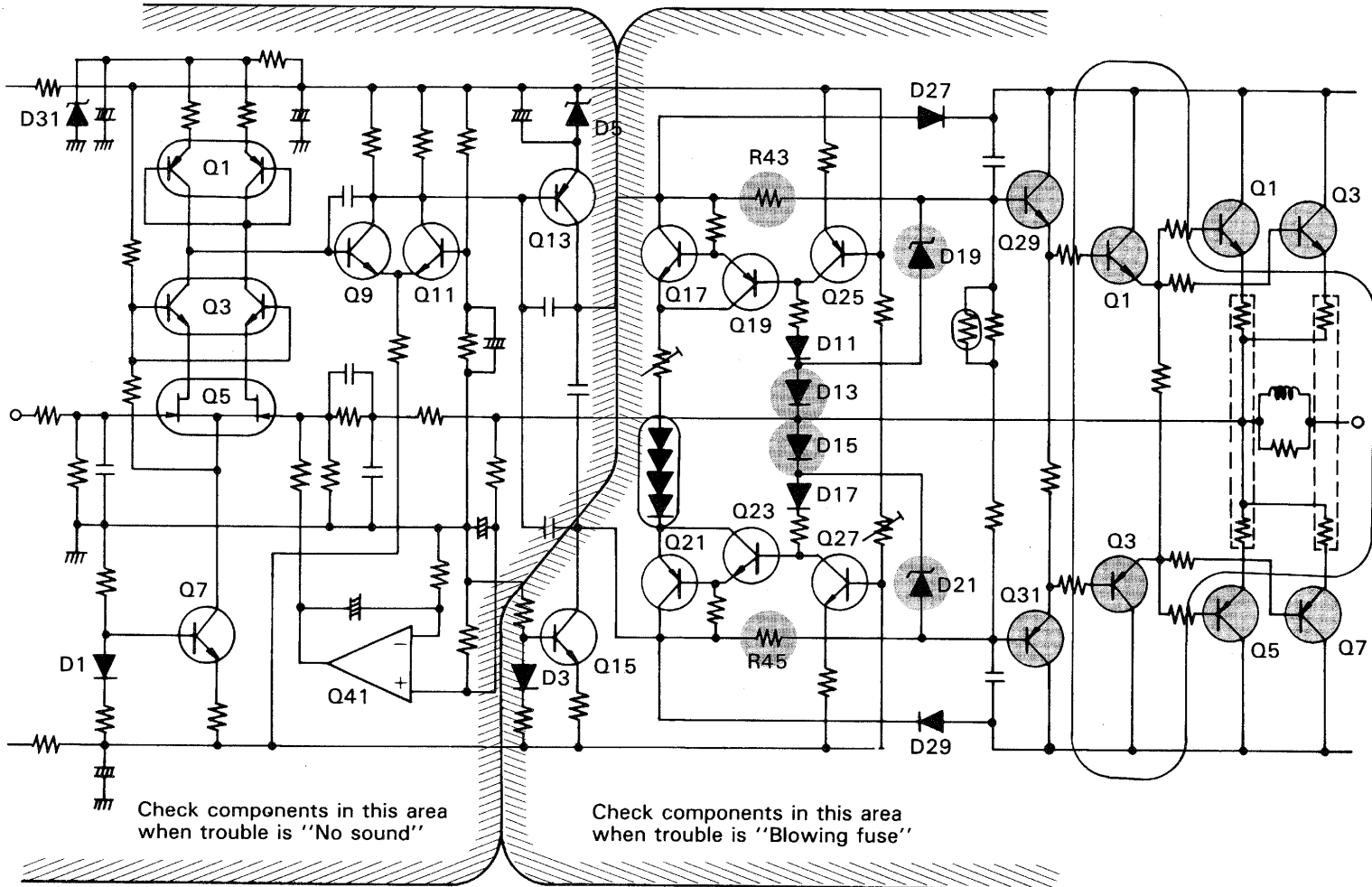


Fig. 94 Causes of troubles of A-9 power amplifier

### c) Other troubles

We have discussed how to trouble shoot the typical causes of “Fuse blows out.” and “No sound” of NSA. Here, we will see other troubles which commonly arise in most amplifiers, including NSAs.

- 1) Distortion
- 2) Residual noise
- 3) Intermittent sound at low level
- 4) Click noise right after powered on
- 5) Excessive heat with no input

#### 1) Distortion

Causes:

- i) Unbalanced center voltage and insufficient idle current
- ii) Improper bias voltage on each stage
- iii) Decreased power supply voltage

Points to be checked:

- i) If distortion is easily audible, check bias voltage on every stage.
- ii) If distortion is hardly audible, use a distortion meter and an oscilloscope.
- iii) NSA employs zener diodes  $D_{21}$  and  $D_{23}$  in front of driver transistors  $Q_{29}$  and  $Q_{31}$ . If  $D_{23}$  is short-circuited,  $Q_{31}$  and  $Q_2$  will stop working and sound will distort very much. If both diodes are short-circuited, no sound will come out.
- iv) If NSA's idle current control transistors ( $Q_{17}$ ,  $Q_{19}$ ) are short-circuited, the distortion will be too low to be heard. This is crossover distortion.

Crossover distortion can be observed on oscilloscope. Switching distortion, however, is very low and can only be found through the monitor terminal of a distortion meter.

Anyway, observing the waveform is necessary.

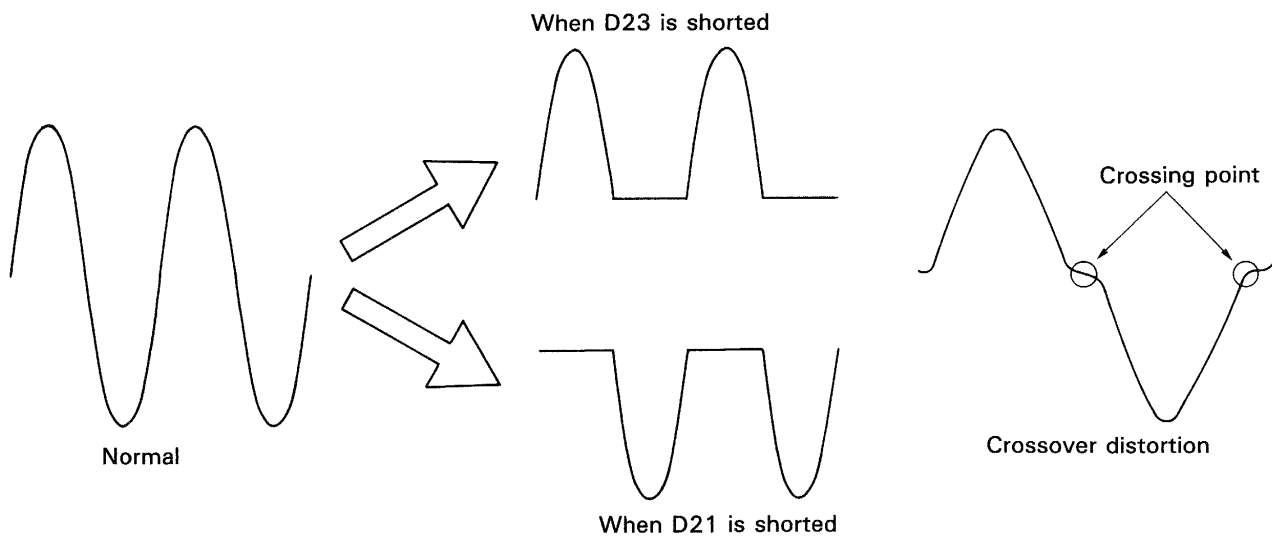


Fig. 95 Output waveform

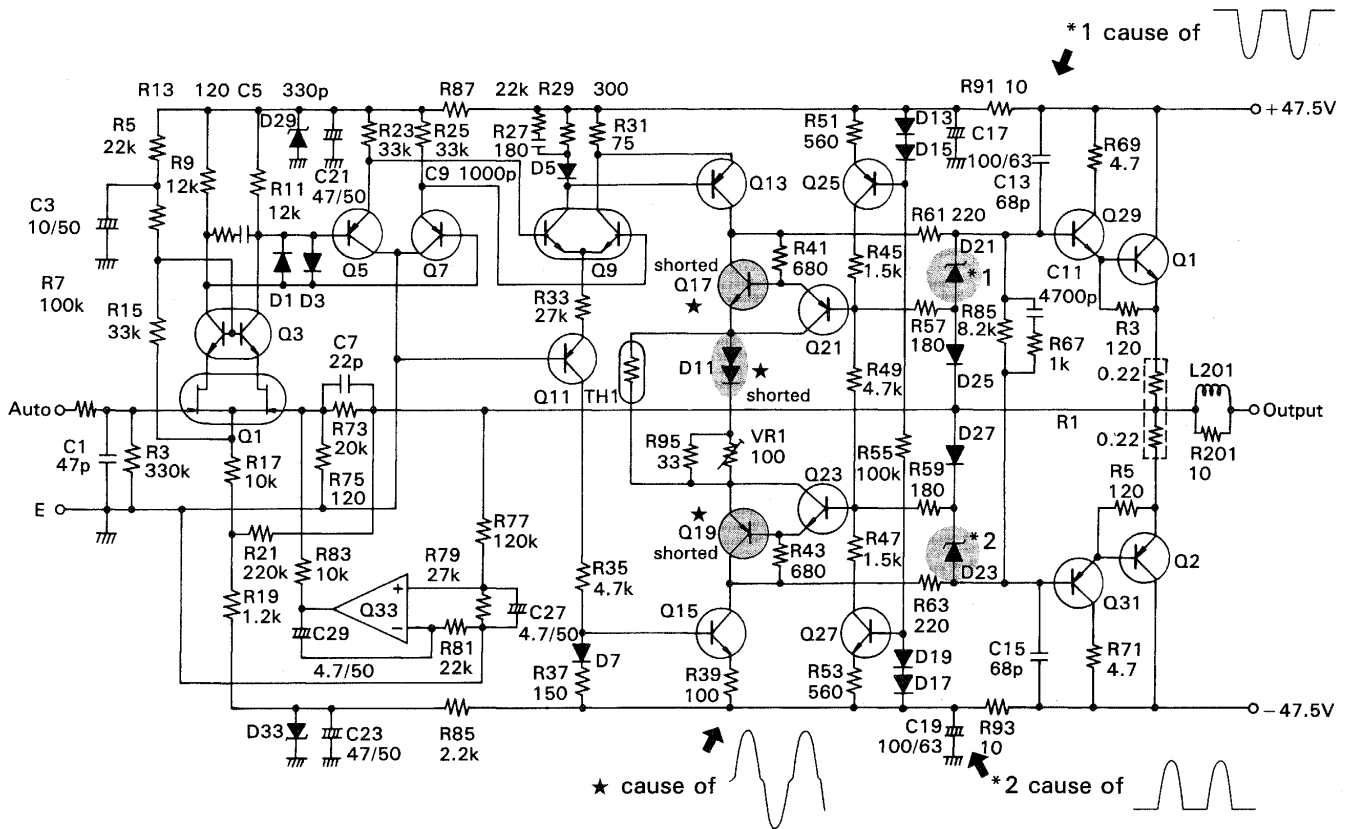


Fig. 96 Suspected components in the case output distorts

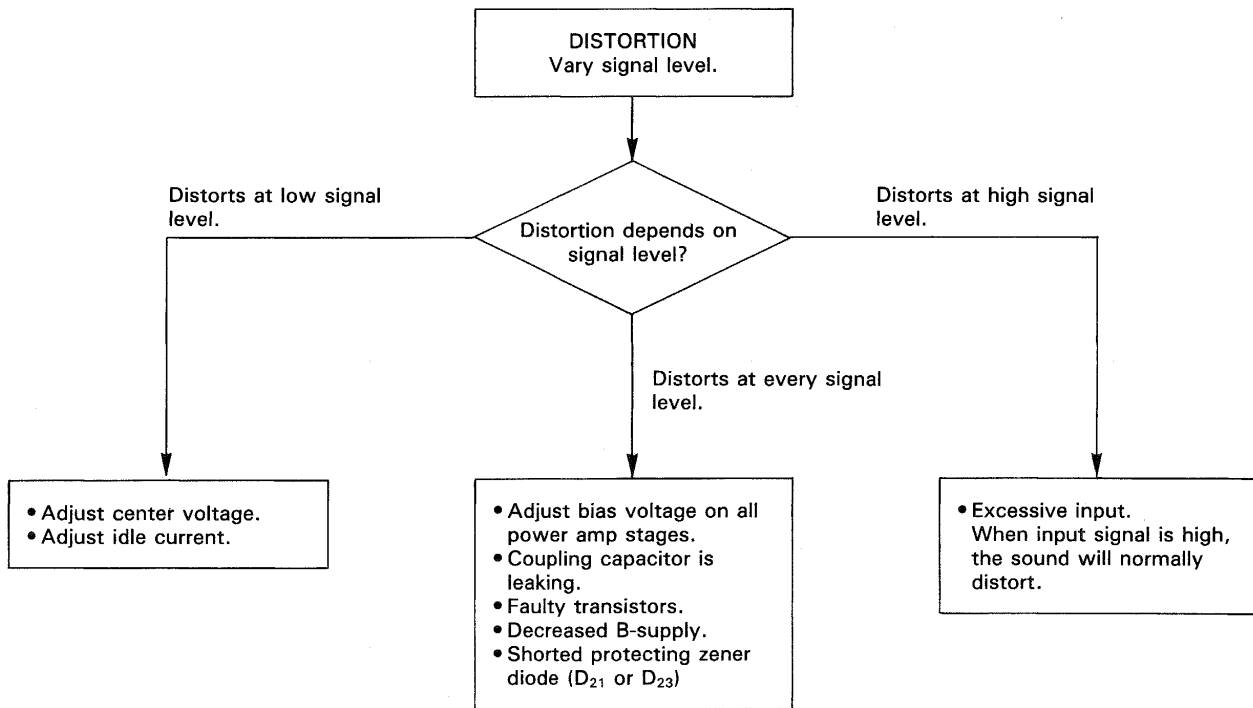
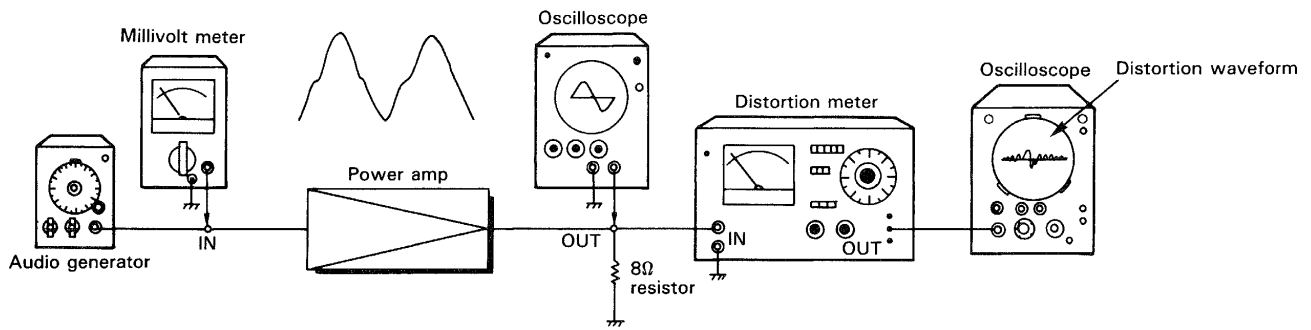


Fig. 97 Troubleshooting chart



**Fig. 98** Confirming output

**Note**

After replacing transistors and other faulty components in bias or driving stage, be sure to adjust idle current to prevent crossover distortion or overheating of transistors. Finally, confirm that the output does not distort or oscillate at the rated output.



## 2) Noise

### Causes:

- i) Worn out 1st stage transistor.
- ii) Faulty electrolytic capacitor.
- iii) Nearly shorted or opened component or pattern, poor soldering, or poor contact of switch.
- iv) Nearly opened transformer or other components in Power Supply block.

### Troubleshooting:

Normally, when transistors are worn out, their heat appear to be corroded in black. In this case, the corrosion may have penetrated inside, thus causing noise. (iii) can be checked by applying mechanical shock to an assembly or component with tweezers or the grip of a screw driver.

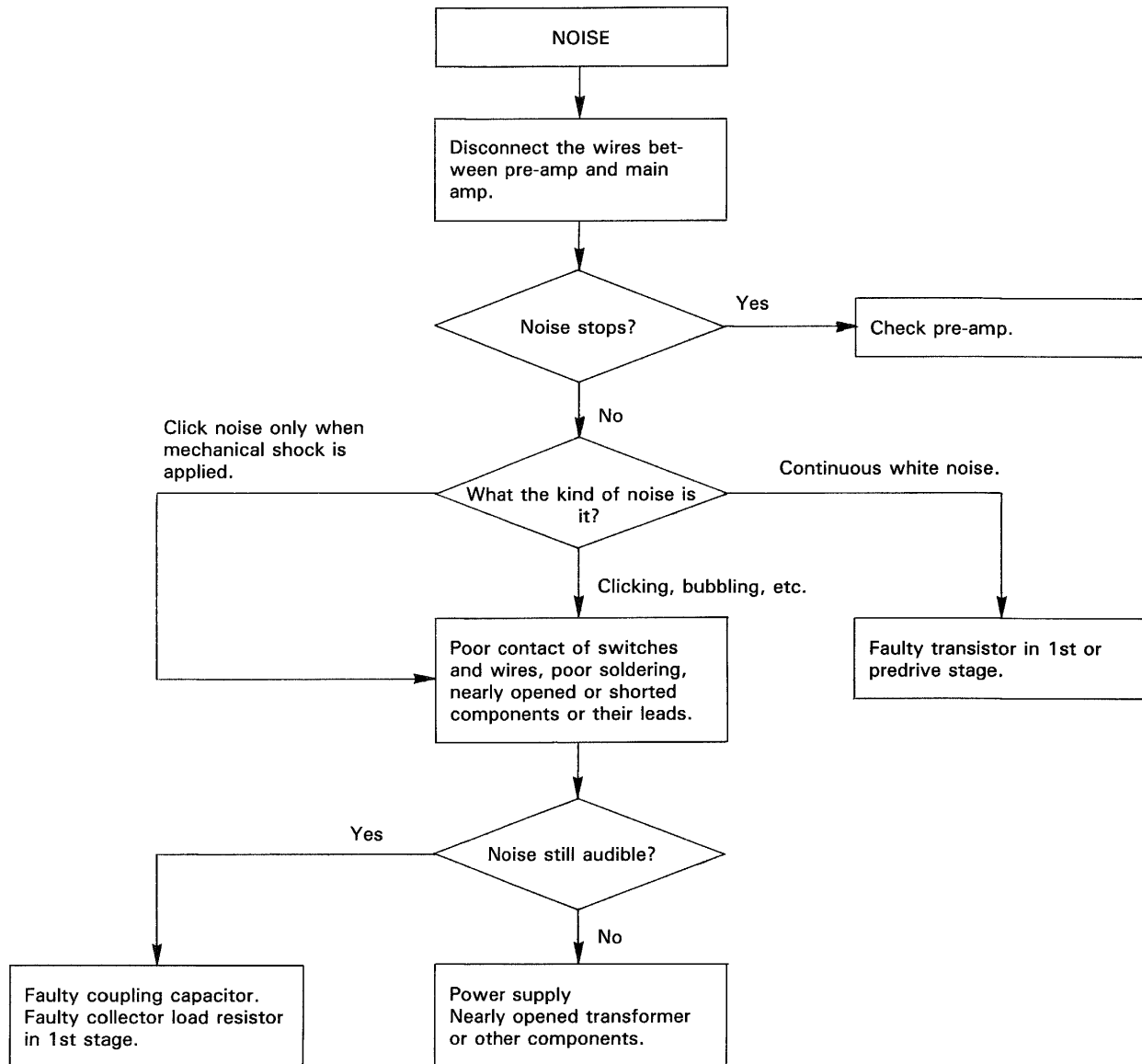


Fig. 99 Troubleshooting chart

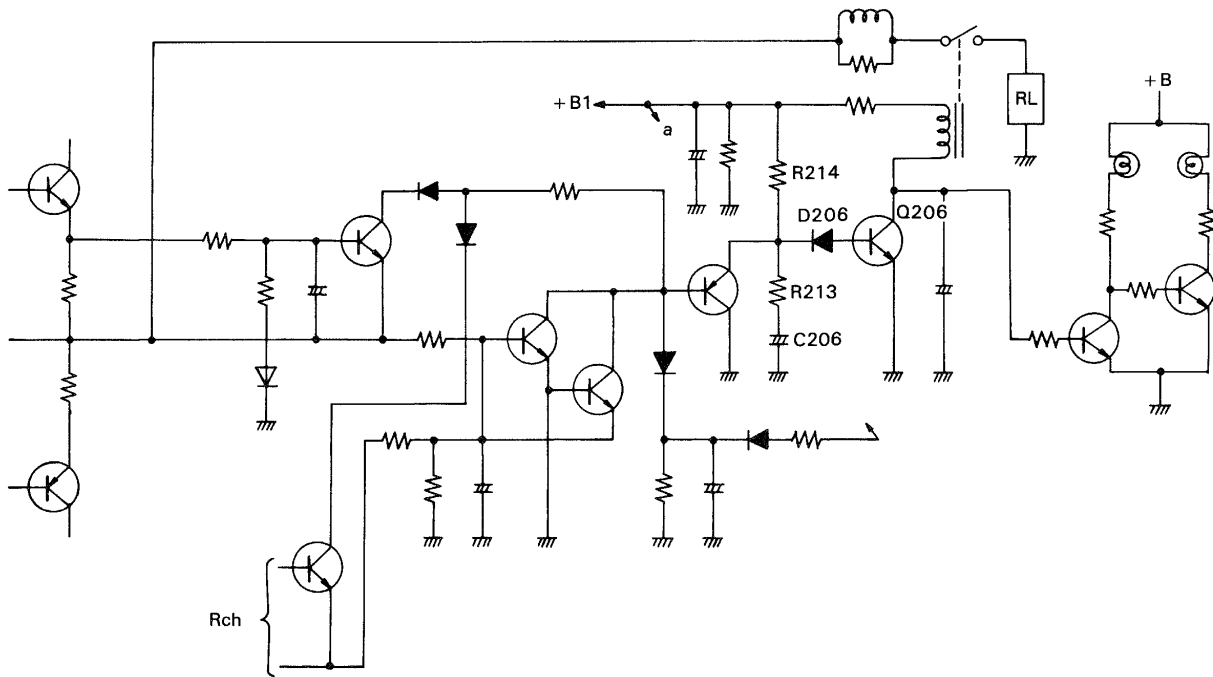


Fig. 100 Protection circuit

**3) Intermittent sound when sound level is low**

Causes:

- i) Poor contact(s) of relay.
- ii) Nearly opened switch, leads or wires.

Points to be checked:

- i) If the problem is traced to the main-amp, and sound becomes intermittent at low sound volume, poor contact in protection relay.
- ii) It may work normally for a short period after applying mechanical shock or raising sound level.
- iii) Even if the resistance reading of a multimeter across relay terminals is normal, the relay may block small signals.

Remedy:

Replace relay.

**4) Click noise when powered on/off**

Cause:

Faulty muting circuit

The delay time of protection circuit is normally 5~10 seconds.

In the case of A-7, it is determined by the time constant of R<sub>213</sub>, R<sub>214</sub> and C<sub>206</sub>, and D<sub>206</sub>.

If the capacitance of C<sub>206</sub> is remarkably decreased, or Q<sub>206</sub> is short-circuited, the delay time will become extremely short.

In that case, popping noise will be generated.

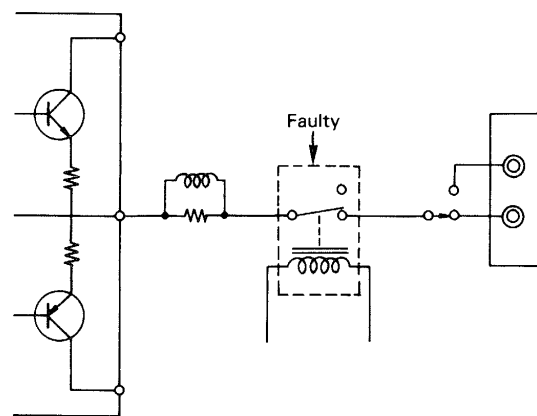


Fig. 101 Faulty component

**5) Amplifier becomes hot even when the sound level is low.**

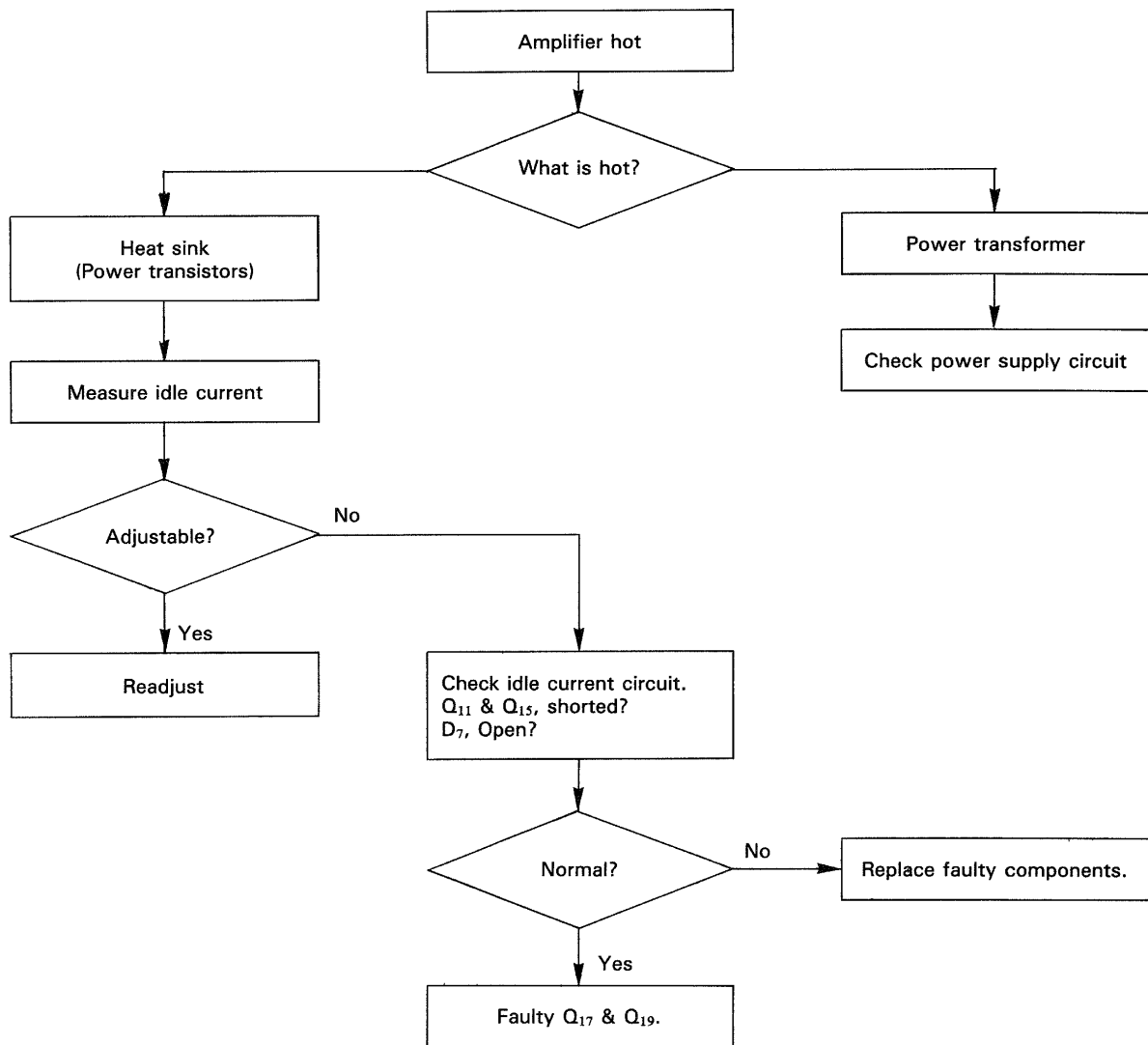
Causes:

- i) Improper adjustment of idle current
- ii) Faulty idle current circuit
- iii) Faulty biasing circuit
- iv) Faulty power supply circuit

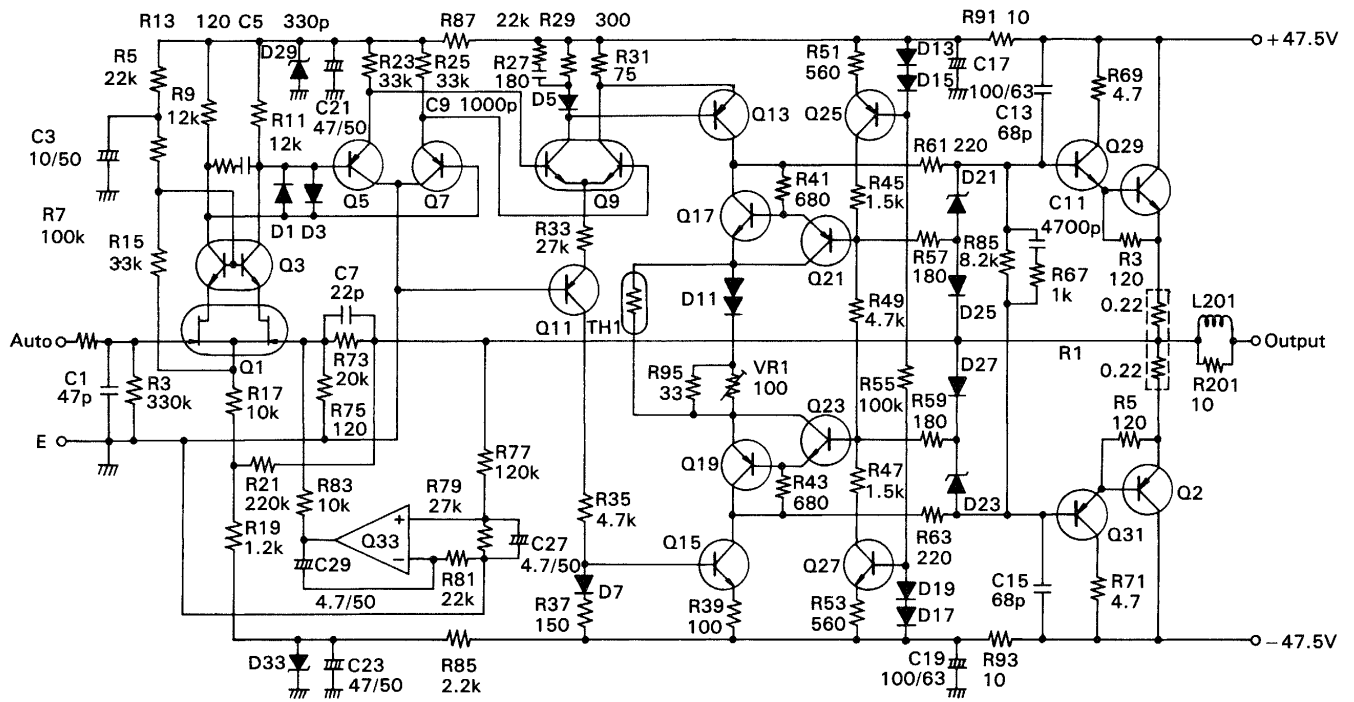
Points to be checked:

- i) The heat may be generated in power transistors by excessive idle current or in power transformer by excessive power current.

- ii) In many cases when power transistors become hot, power transformer also becomes hot.
- iii) Class-A amplifiers normally become hot irrespective of the sound volume.
- iv) In NSA amplifiers, idle current circuit and biasing circuit are interlaced complicately. Both of the circuits should be checked if it is still hot after adjusting idle current.

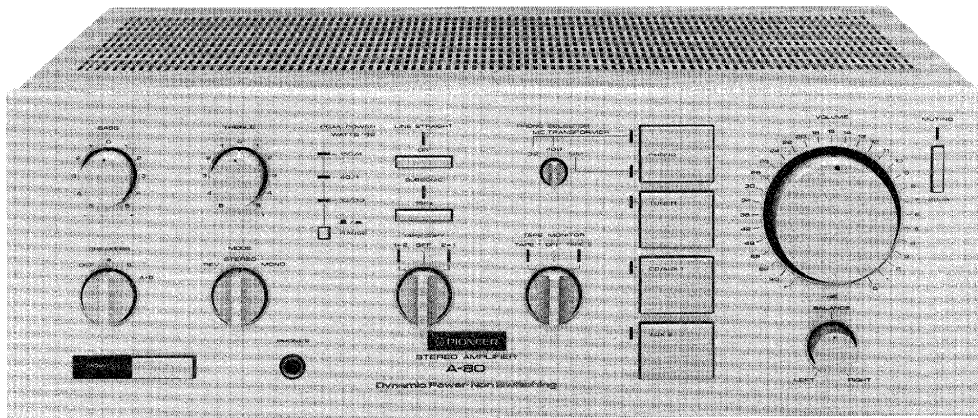


**Fig. 102 Troubleshooting chart**



**Fig. 103 Suspected components in the case amplifier becomes hot**

# Dynamic Power Supply



# CONTENTS OF DYNAMIC POWER SUPPLY

## I EFFICIENT AMPLIFIER

1. Why Is a Powerful Amplifier Required? .....	3
2. General Description .....	4
3. Calculating Dissipation .....	6

## II CIRCUIT PRINCIPLE

1. Differential Amplifier .....	7
a) When no input signal is applied. ....	8
b) When DPS circuit starts working (8Ω load). ....	9
c) When speakers are disconnected. ....	10
d) When producing the signals of 150W maximum (8Ω load). ....	10
e) When the output power is 120W (8Ω load). ....	12
2. HIGH-ON Circuit .....	13
2-1 Maintaining $V_H$ by HIGH-ON circuit .....	15
2-2 Function of each component in HIGH-ON circuit .....	16

## III TROUBLE-SHOOTING

1. Diagnosis and Point to Be Checked .....	17
2. Cause and Effect .....	19
2-1 $V_a$ stays at $V_L$ . ....	19
2-2 $V_a$ stays at $V_H$ all the time. ....	20
2-3 Differential detector is inactive ( $V_a$ stays at $V_L$ ). ....	21
2-4 HIGH-ON circuit starts working although the frequency and level of input signals are low. ....	21
2-5 By-running $V_a$ is not high enough. ....	22
2-6 In high frequency range HIGH-ON circuit is inactive but Differential Detector is working. ....	22
3. Trouble-shooting Flowchart .....	23

IV FET BUFFER CIRCUIT (A-90) .....	27
------------------------------------	----

# I. EFFICIENT AMPLIFIER

## 1. Why Is a Powerful Amplifier Required?

Everybody will agree that a powerful amplifier is necessary for a large room. However, recently there has been a growing demand for audiophiles for powerful audio systems in average-sized rooms.

The effort to reproduce high fidelity sound has been made by decreasing distortion and noise and extending frequency bandwidth and dynamic range (the difference between the overload signal level and the minimum acceptable level). This approach has led to satisfactory results except in dynamic range.

With conventional amplifiers, we are still unable to have the feeling of "presence" that we get from a live performance. The reason for this is that live music has a much wider dynamic range than that ordinarily reproduced by an audio system.

The dynamic range of the conventional recording system has been limited to 70 dB or so. The newly developed Digital Audio Disc (or Compact Disc) and PCM tape contain the sound information for a wider dynamic range of more than 90 dB. To reproduce the high quality sources, the peripheral equipment to the Compact Disc player, especially Power amplifiers, should be upgraded. To make a powerful amplifier, powerful and reliable transistors and voltage supply and large heat sinks are required. The performance of many other component parts should also be high. Pioneer has answered the requirement for more powerful and energy saving amplifiers by developing the Dynamic Power Supply (DPS) circuitry.

	PCM digital processor	Reel-to-reel analog tape deck (38cm/sec stereo)	Compact Disc digital player (PD-70)
Frequency response	10Hz – 20kHz ±0.5dB	30Hz – 20kHz ±3dB	5Hz – 20kHz ±0.5dB
Distortion	Less than 0.005%	Less than 0.5%	Less than 0.004% (1kHz, 0dB)
Wow/flutter	Unmeasurably low	0.02% wrms	Quartz oscillator accuracy
Dynamic range	More than 90dB	More than 64dB	More than 95dB (1kHz)
Cross talk (channel separation)	80dB	Inter channel 50dB Inter track 68dB	More than 90dB (1kHz)

**TABLE 1**  
Performance of PCM processor, analog tape deck and Compact-disc player

The necessary acoustic power (amplifier's output power × speaker's efficiency) for an average-sized listening room has been said to be about 10mW (about 86 dB by Acoustic Power Level (APL)). The APL of the digital music source sometimes exceeds 109 dB. This means 23 dB higher than the average level or 200 times of the level.

$$109 \text{ [dB Peak APL]} - 86 \text{ [dB Average APL]} = 23 \text{ [dB Peak factor or difference]}$$

To reproduce the sound of 109 dB completely with a speaker of 1% efficiency, a 200W amplifier is required.

$$10 \text{ [mW Acoustic Power]} \times 100 \text{ [Reciprocal of 1\% speaker efficiency]} \times 200 \text{ [times]} = 200 \text{ [W]}$$

A-90 fulfills this requirement.

## 2. General Description

Conventional low-powered amplifiers can perform satisfactorily if you do not expect the reproduction of powerful pulsive sound because music sound stays small most of the

time and it becomes large only for a very short period, a few percent of the total period, and high-powered amplifiers lose power idly in the other period.

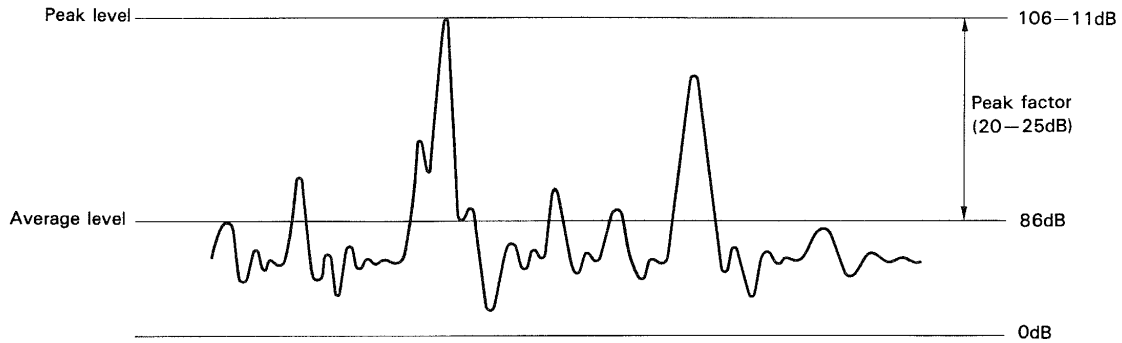


Fig. 1 Audio signal level

To reduce the idle power, the DPS usually supplies the output stage with a low voltage and with a high voltage only when the signal becomes large. Fig. 2 shows the simplified diagram of the DPS system.

The system has a pair of low voltage ( $V_L$ ) lines, high voltage ( $V_H$ ) lines and Differential Detectors (level sensor) and one HIGH-ON circuit (high frequency sensor) on each channel. When the output level is low, only  $V_L$  is supplied. When the Differential Detector senses that output level exceeds a threshold level, the DPS increases supply voltage ( $V_a$ ) and keeps it higher than output voltage by 18 V or so synchronizing the output signal.

To increase power efficiency is to decrease dissipation which is the loss of electric energy as heat. The higher the dissipation, the lower, the efficiency. Dissipation also depends on the biasing condition of power transistors.

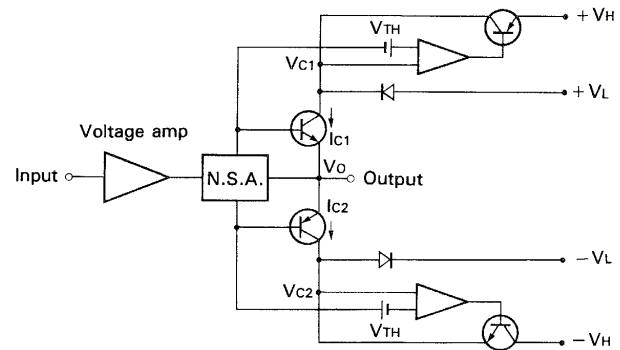


Fig. 2 Simplified diagram of DPS system

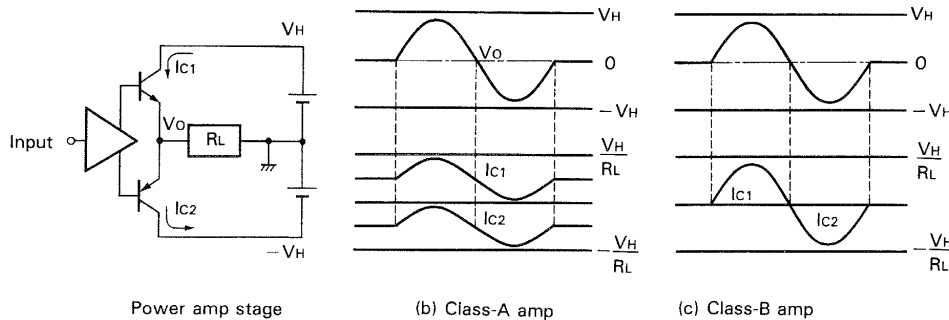


Fig. 3 Voltage (current) waveforms of class-A and class-B amplifiers



Fig. 3 shows the output waveforms of the voltage or current of Class-A and Class-B amplifiers. The collector dissipation of Class A and Class B amplifiers will be discussed later.

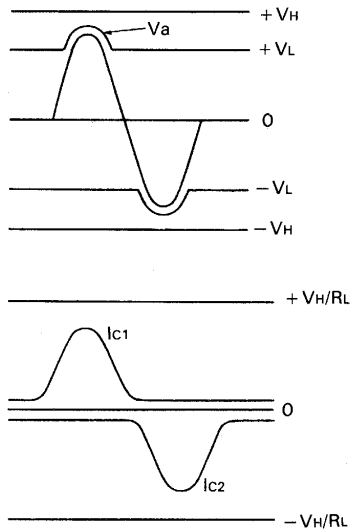


Fig. 4 Voltage (current) waveforms of DPS NSA.

The waveforms of output voltage ( $V_o$ ) and the supply voltage ( $V_a$ ) of the DPS amplifier are shown in Fig. 4.

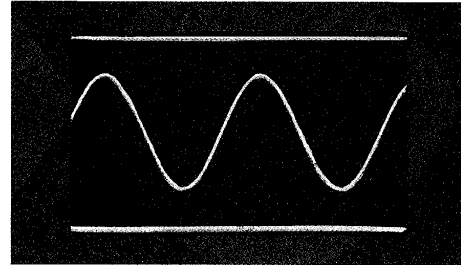


Photo 1-a; When the level and frequency of output signal are low.

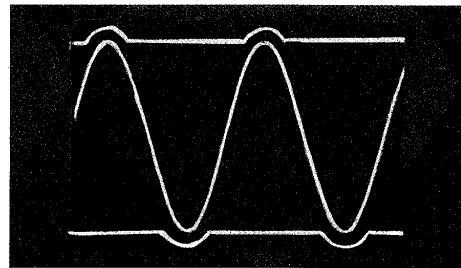


Photo 1-b; When the level becomes high

In Photo 1-a,  $V_a$  is maintained at  $V_L$  when the signal level is low. In Photo 1-b,  $V_a$  becomes higher than  $V_L$  in the period the output voltage exceeds a threshold ( $V_{TH}$ ). There will be a problem when the output frequency becomes high. The transistors controlling  $V_a$  may not be able to follow or by-run the quickly undulating high frequency signal in real time. The HIGH-ON circuit has solved this problem. When the signal frequency and level exceed a certain point, the HIGH-ON circuit immediately takes over, and switches the supply voltage to  $V_H$ . Photo 1-c shows that  $V_a$  shifts to  $V_H$  when a high frequency signal is applied to the circuit. In this case, the high voltage is maintained for several microseconds after the signal becomes small in order to prepare for the next pulsive signal which often appears in classical music. The HIGH-ON circuit also prevents the  $V_L$ - $V_H$  switching noise which may arise in high frequency operation. The HIGH-ON circuit starts working before  $V_o$  reaches  $V_{TH}$  when the signal frequency is high.

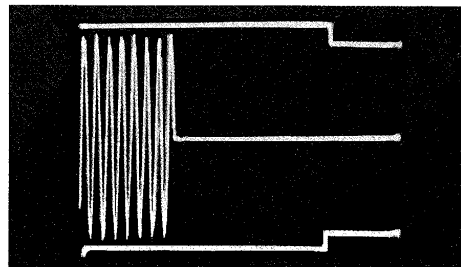


Photo 1-c; When the level and frequency become high

Photo 1 Output signal and supply voltage

$V_{TH}$ : The threshold level of the Differential Detector

### 3. Calculating Dissipation

Let's see how to calculate the dissipation under various conditions.

Collector dissipation (Pc) of Class-A amplifier:

$$P_C = \frac{1}{2\pi} \int_0^{2\pi} V_M(1 - K \sin \omega t) \cdot \frac{V_M}{2R_L} (1 + K \sin \omega t) d\omega t = \frac{V_M^2}{2R_L} \left(1 - \frac{K^2}{2}\right) [W]$$

Pc of Class-B amplifier:

$$P_C = \frac{1}{2\pi} \int_0^\pi V_M(1 - K \sin \omega t) \cdot \frac{V_M}{R_L} K \sin \omega t d\omega t = \frac{V_M^2}{2R_L} \left(\frac{2k}{\pi} - \frac{k^2}{2}\right) [W]$$

Pc of DPS amplifier:

In the formulas,

$V_L$ : Low supply voltage [V]

$V_H$ : High supply voltage [V]

$V_{OP}$ : Peak output level [V]

$V_{TH}$ : Threshold level [V]

$K$ : Output voltage ratio  $V_{OP}/V_H$

$$x = \frac{V_H}{V_L}, \quad y = \frac{V_L - V_{TH}}{V_H}, \quad z = \frac{V_H - V_{TH}}{V_H}$$

$$\theta_1 = \sin^{-1}\left(\frac{y}{k}\right), \quad \theta_2 = \sin^{-1}\left(\frac{z}{k}\right)$$

(1) When  $0 < K = \frac{V_{OP}}{V_H} < y$  or  $0 < \frac{V_{OP}}{V_H} < \frac{V_L - V_{TH}}{V_H}$ ;

$$P_{C1} = \frac{1}{2\pi} \int_0^\pi V_H(x - K \sin \omega t) \cdot \frac{V_H}{R_L} K \sin \omega t d\omega t = \frac{V_H^2}{2R_L} \left(\frac{2xk}{\pi} - \frac{k^2}{2}\right) [W]$$

(2) When  $y < K < z$  or

$$\frac{V_L - V_{TH}}{V_H} < \frac{V_{OP}}{V_H} < \frac{V_H - V_{TH}}{V_H};$$

$$P_{C2} = \frac{1}{\pi} \left[ \int_0^{\theta_1} V_H(x - \sin \omega t) \cdot \frac{V_H}{R_L} K \sin \omega t d\omega t + \int_{\theta_1}^{\frac{\pi}{2}} V_{TH} \cdot \frac{V_H}{R_L} K \sin \omega t d\omega t \right] = \frac{1}{\pi} \left[ \frac{V_H}{2R_L} \left\{ 2x(1 - \cos \theta) - K \left( \theta_1 - \frac{\sin \theta}{2} \right) \right\} + V_{TH} \frac{V_H}{R_L} K \sin \theta_1 \right] [W]$$

(3) When  $z < K < 1$ ;

$$P_{C3} = \frac{1}{\pi} \left[ \int_0^{\theta_1} V_H(x K \sin \omega t) \frac{V_H}{R_L} K \sin \omega t d\omega t + \int_{\theta_1}^{\theta_2} V_{TH} \frac{V_H}{R_L} \sin \omega t d\omega t + \int_{\theta_2}^{\frac{\pi}{2}} V_H(1 - K \sin \omega t) \frac{V_H}{R_L} K \sin \omega t d\omega t \right] = \frac{1}{\pi} \left[ \frac{V_H^2}{2R_L} \left\{ 2x(1 - \cos \theta_1) - A \left( \theta_1 - \sin^2 \theta_1 \right) \right\} + V_{TH} \frac{V_H}{R_L} K (\cos \theta_1 - \cos \theta_2) + \frac{V_H}{2R_L} \left\{ 2y \cos \theta_2 - K \left( \frac{\pi}{2} - \theta_2 + \frac{\sin \theta_2}{2} \right) \right\} \right] [W]$$

To obtain the value of the whole dissipation in the output stage, the above result should be doubled because it relates only to the positive side of the push-pull circuit. In DPS amplifiers, another dissipation in the power regulating transistors in the power supply block should also be considered. If we take these points into consideration, we have the following equations:

When  $y < K < z$ ;

$$P_{S1} = \frac{V_H^2}{2\pi R_L} K \left\{ 2(1 - x + y) \cos \theta_1 - A \left( \frac{\pi}{2} - \theta + \frac{\sin \theta}{2} \right) \right\} [W]$$

When  $z < K < 1$ ;

$$P_{S2} = \frac{V_H^2}{2\pi R_L} K \left\{ 2(1 - x + y) (\cos \theta_1 - \cos \theta_2) - A \left( \theta_2 - \theta_1 + \frac{\sin 2\theta_1 - \sin 2\theta_2}{2} \right) \right\} [W]$$

Fig. 5 shows the relation between the dissipation, and the output power of a (8Ω load) 200W amplifier. You will see that the efficiency of the conventional Class-B amplifier becomes low as the output approaches to the medium. The broken line shows the total Pc consumed in the power stage and the power supply block. The Pc of the DPS amplifier is far lower than that of Class-A amplifiers and is almost a half of that of the conventional Class-B amplifiers. The shaded area shows the improved amount.

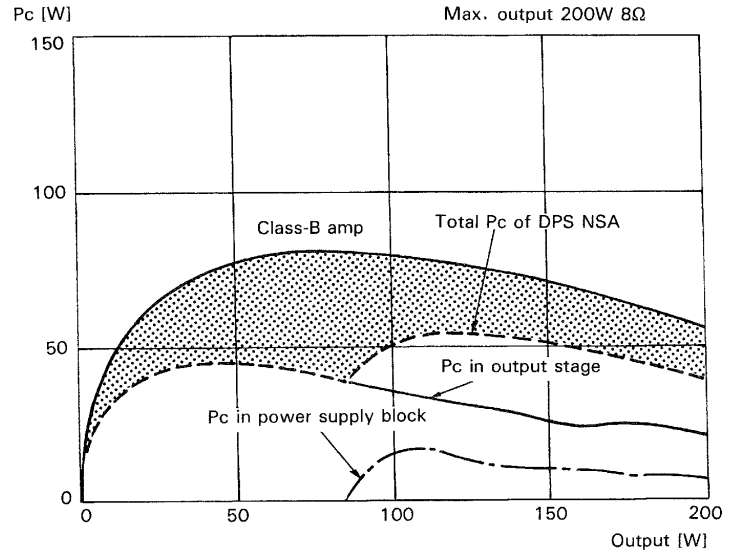


Fig. 5 Output power VS. dissipation

## II. CIRCUIT PRINCIPLE

Fig. 6 shows another simplified diagram of DPS. The supply voltage to the power stage ( $V_a$ ) is compared with the output voltage ( $V_o$ ) and is controlled by the Differential Detector. With an additional offset voltage,  $V_a$  is maintained higher than  $V_o$  when the input and output signals are high. If  $V_o$  is lower than  $V_L - V_{TH}$ ,  $V_a$  stays at  $V_L$ . The HIGH-ON circuit shifts  $V_a$  from  $V_L$  to  $V_H$  when the output signal frequency and level become high, and it maintains the level for a certain period after the high frequency signal disappears or becomes small.

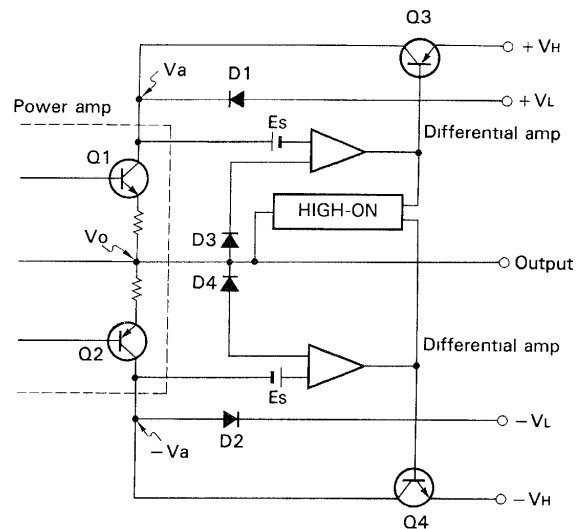


Fig. 6 Simplified circuit of DPS system

### 1. Differential Amplifier (For Low Frequency)

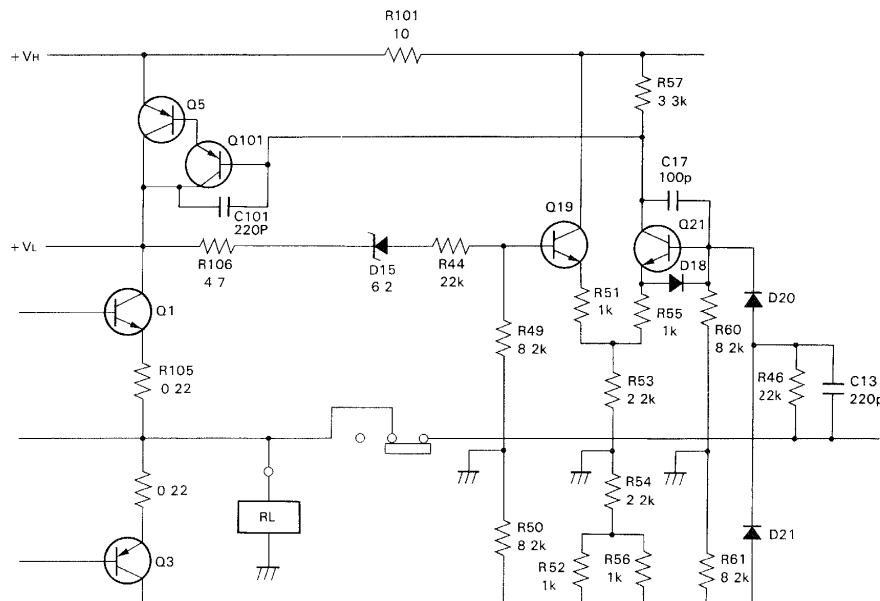


Fig. 7 DPS circuit of A-80

The A-90 series employ the DPS system. Among them, A-80 will be discussed here. Let's see the operation in the period when the input signal is positive. The output signal is rectified by D20, divided by R46 and R60, and is applied to Q21's base. When the signal is small and the voltage of rectified current is lower than 10.2 V at Q21's base, Q1's collector voltage ( $V_a$ ) is maintained at  $V_L$ . When Q21's base voltage ( $V_B$ ) exceeds 10.2 V, Q21 turns on, collector current ( $I_c$ ) flows, and Q19 turns off because Q19 and Q21 compose a differential amplifier. Q21's collector voltage ( $V_c$ )

falls, and Q101's  $V_B$  falls. Darlington circuit, composed of Q101 and Q5, turns on.  $V_a$  is shifted from  $V_L$  (60 V) to  $V_H$  (80 V).  $V_a$  is then applied to R106 and D15, divided by R44 and R49 and applied to Q19's Base. Then, Q19 turns on and Q21 turns off. The Differential amplifier is balanced when  $V_a$  is higher than  $V_o$  by some ten volts because Q19's  $V_B$  is kept low by the voltage across R106, D15 and R44. Here,  $V_a$  does not shift between  $V_L$  and  $V_H$  digitally but varies gradually maintaining its level at  $V_L + V_d$  because of the offset voltage and negative feedback via Q21, Q101

and Q5. The circuit responds in real time having no capacitor in the loop. Q19's  $V_B$  quickly follows the variation of Q21's  $V_B$ .  $V_a$  and  $V_o$  vary as in Fig. 8.

$V_d$  is determined by the 6.2 V zener voltage and the ratio of R49 to R44. R106 of  $47\Omega$  is negligible.  $V_d$  has been set at about 18 V in A-80.

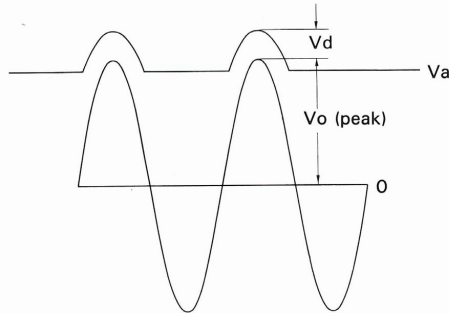


Fig. 8 When  $V_o$  becomes high

**Waveforms of  $V_o$  and  $V_a$  under various conditions.**

a) When no input signal is applied.

Q21 is off because its base has been grounded by R60, no current flows in R60 and Q21's  $V_B$  is 0V. Q19 is on. Q19's  $I_c$  flows in R51 and then branches off and flows in R53,

and through R55, D18 and R60. Q21's emitter voltage  $V_E$  rises. Q21 remains off because of its reverse bias. Q5 and Q101 are kept off and thus  $V_a$  is kept at  $V_L$ .

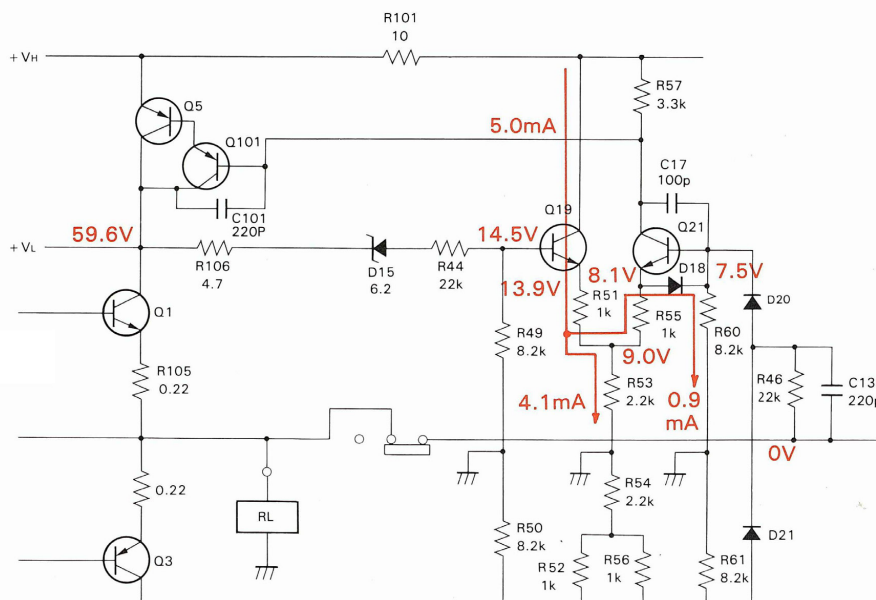


Fig. 9 Voltage and current values at each point

b) When DPS starts working with 8Ω speaker (load) connected.

Q21's  $V_B$  rises and Q21 turns on when the output voltage reaches a threshold level. Q21's  $V_c$  drops, and Q101 and Q5 are turned on because their  $V_{BE}$ s are increased. Fig. 10

shows the voltage and current readings in the circuit and the waveforms of  $V_o$  and  $V_a$  at the moment Q101 and Q5 turn on.

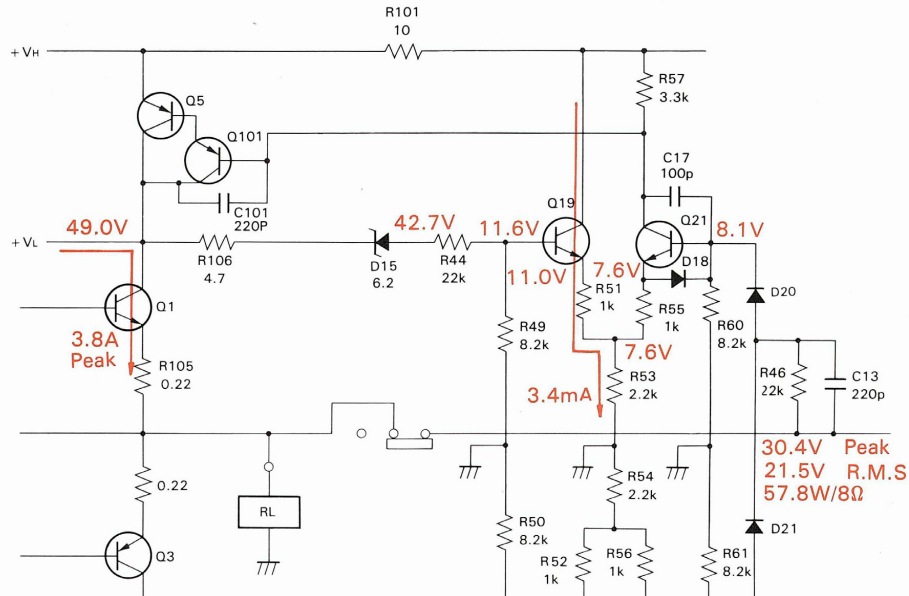


Fig. 10-a Voltage, current and waveforms when DPS starts working

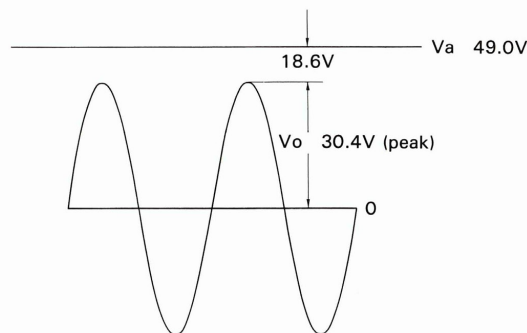


Fig. 10-b Output and power supply waveforms when DPS starts working

The output power at this time can be calculated with the following equation:

$$\{(x - 0.6) \times 8.2\} / 30.2 = 8.1 [V]$$

$$x = 30.4 [V \text{ peak}]$$

$$21.5 [V_{rms}] (57.8W / 8 \Omega)$$

Q1's  $I_c$  is:

$$\sqrt{\frac{57.8}{8}} \times \sqrt{2} = 3.8 [A \text{ peak}]$$

Q1's  $V_c$  ( $V_a$ ) is kept at  $V_L$  until the output level exceeds the threshold. When the signal current (3.8 A max.) flows in the 8Ω load, the internal resistance in the power supply block decreases  $V_a$  from 59.6 V to 49.0 V.

c) When speakers are disconnected.

$V_L$  becomes 59.6 V when the speaker circuits are opened because no current flows in R105. Fig. 11 shows the voltage and current readings in the circuit at the time when

the speakers are disconnected. The DPS amplifier, however, works when the input signal is increased and  $V_a$  rises even if the load is disconnected.

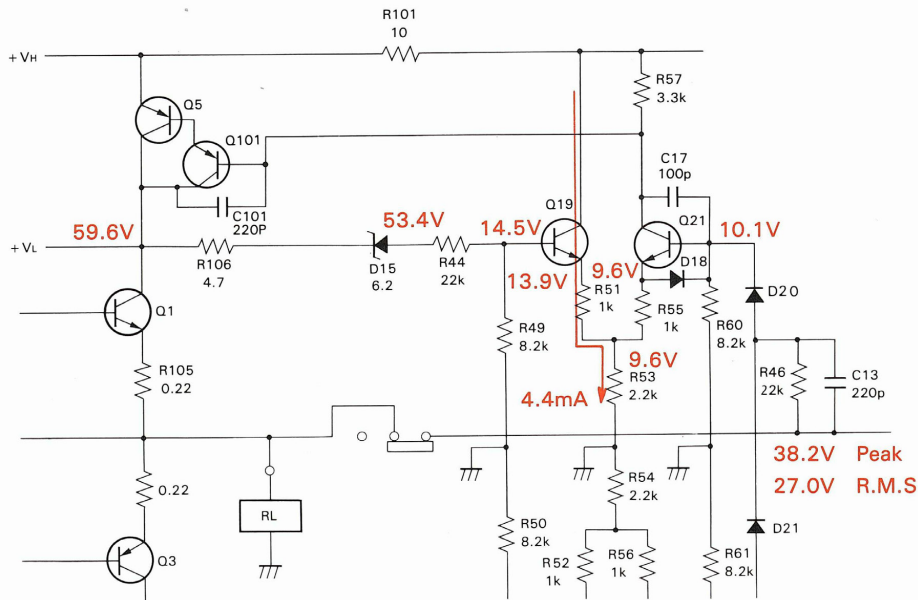


Fig. 11-a Voltage and current reading when speakers are disconnected and the output voltage is 38.2 V at the peak.

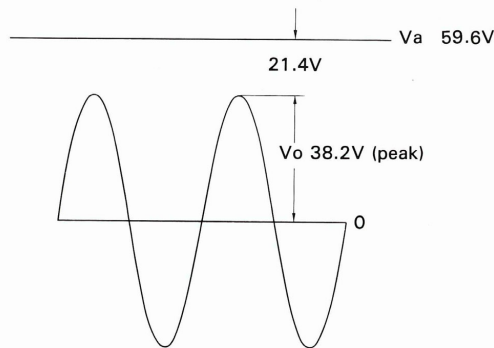


Fig. 11-b Output and power supply waveforms when speakers are disconnected

d) When the output power is 150W maximum (8Ω load).

When the output is 150W/8Ω, the output voltage becomes 48.8 V at the peak. Q21's  $V_B$  and  $V_E$  become 13.1 V and 12.5 V respectively, and Q101 and Q5 turn on.  $V_a$  rises from  $V_L$ .  $V_a$  is determined by the Q21's  $I_c$ . If the combined  $h_{fe}$  of Q5 and Q101 is 7,260, the base current ( $I_B$ ) of Q101 will become 0.84 mA because the  $I_c$  is 6.1 A at the peak when the output power is 150W and the load impedance is 8Ω.

$$150[W] = I^2 R = I^2 \times 8[\Omega]$$

$$I = 4.3[A \text{ rms}], 4.3[A] \times \sqrt{2} = 6.1[A \text{ peak}]$$

$$6.1[A] / 7260 = 0.84[mA]$$

As the saturation voltage of the Q5 + Q101 Darlington circuit is 1.2 V, the current in R57 is:

$$1.2[V] / 33[K\Omega] = 0.36[mA]$$

Q21's  $I_c$  is:

$$0.84[mA] + 0.36[mA] = 1.2[mA]$$

The voltage and current at other points are as in Fig. 12. When Q21's  $V_B$  is 13.1 V, Q1's  $V_c$  becomes 64.0 V. Here, the differential amplifier is balanced.

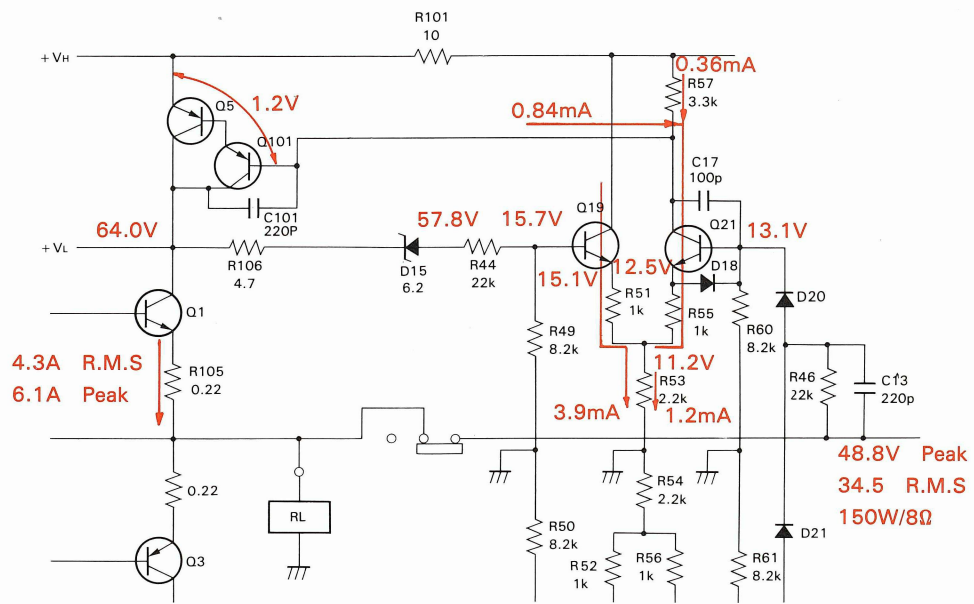


Fig. 12-a Voltage and current reading when producing 150W signals

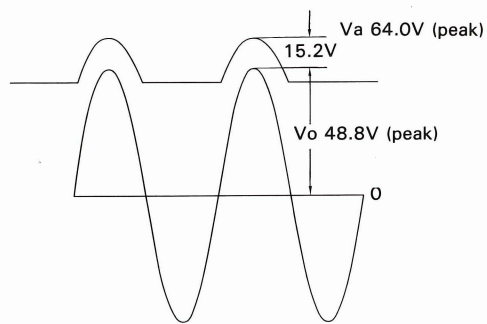


Fig. 12-b Output and power supply voltage waveforms

e) When the output power is 120W (8Ω load).

The voltage and current become as shown in Fig. 13.  
 The combined  $h_{fe}$  of Q5 and Q101 is 7,260.

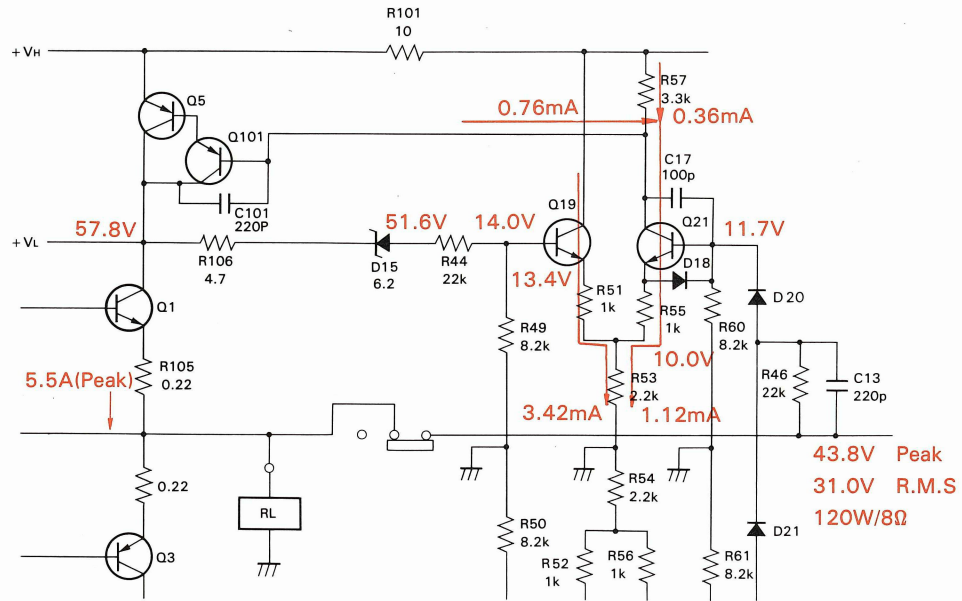


Fig. 13-a Voltage and current readings when output is 120W signal

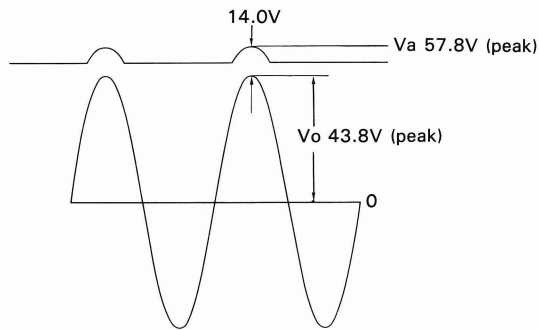


Fig. 13-b Output and power supply voltage waveforms



## 2. HIGH-ON Circuit (For High Frequency)

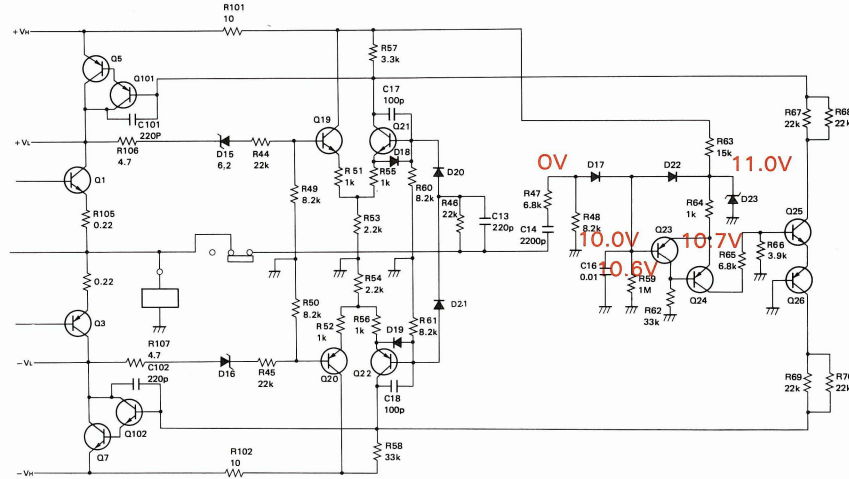


Fig. 14 Dynamic power supply circuit of A-80

When a signal above 3kHz appears at the output, it is smoothed by R47, C14 and R48, turns Q23 off and Q25 and Q26 on, and shifts  $V_a$  from  $V_L$  to  $V_H$  even if the  $V_o$  is lower than the threshold  $V_H$  of the Differential Amplifier, and the  $V_H$  is maintained for a certain period, B msec.

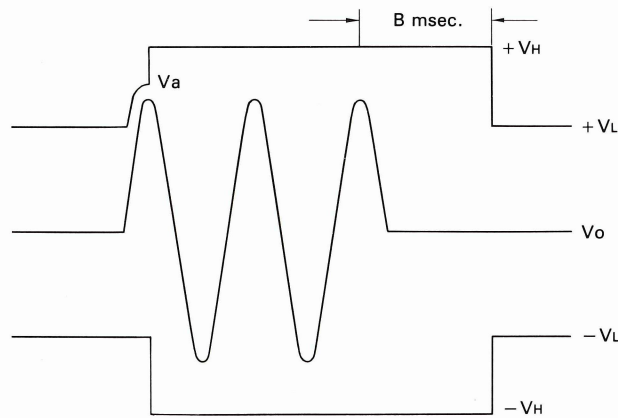


Fig. 15 Waveforms when HIGH-ON works

The circuit and frequency characteristic of the high-pass filter composed of R47, C14 and R48 is shown in Fig. 16.

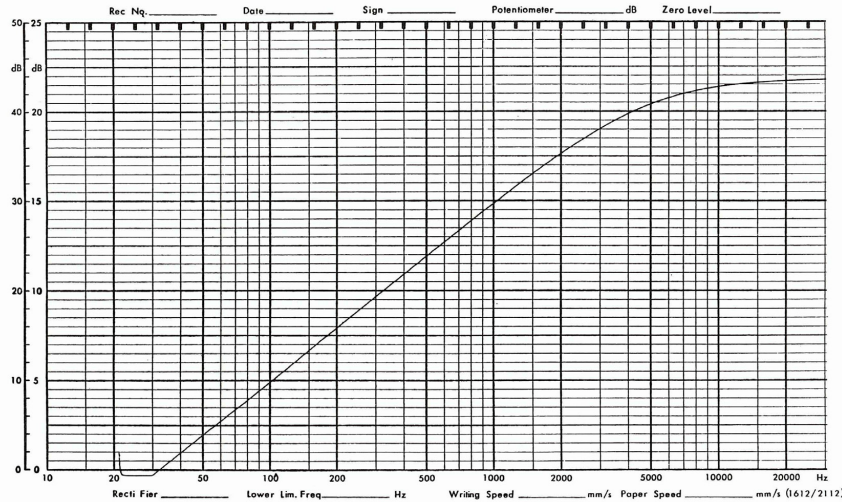
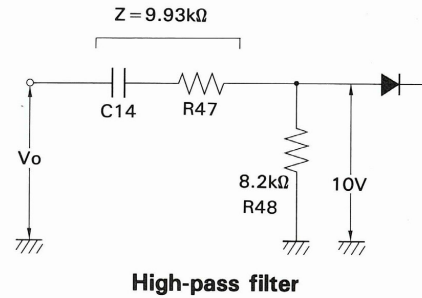


Fig. 16 Characteristic of High-pass filter

With the voltage indicated in Fig. 14, Q23 in the HIGH-ON circuit is usually on, Q24, Q25 and Q26 are off. To activate this circuit, a signal should be fed to Q23's base. Then, Q23 turns off, and Q24, Q25, Q26, Q5 and Q101 turn on. To turn Q23 off and raise  $V_a$  to  $V_H$ , the potential at  $\textcircled{A}$  in Fig. 17 should be more than 10 V. When a 10kHz signal is put out, the combined impedance of C14 and R47 in the high pass filter is:

$$\sqrt{(R_{47})^2 + \left(\frac{1}{\omega C_{14}}\right)^2} = 9.93[K\Omega]$$

Q23 turns off when the potential at  $\textcircled{A}$  exceeds 10 V. The output of the amplifier at this time is:

$$\frac{8.2[K\Omega]}{(9.93+8.2)[K\Omega]} \times V_o = 10.0[V]$$

$$V_o = 22.1[V_{peak}], 15.6[V_{rms}](30.4W/8\Omega)$$

Then,  $V_a$  shifts to  $V_H$ . Fig. 18 shows the threshold level versus signal frequency of the circuit.

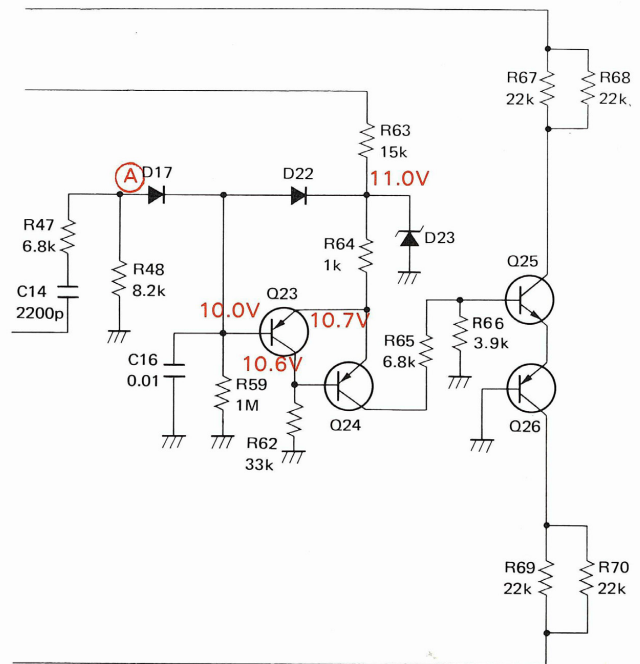


Fig. 17 HIGH-ON circuit

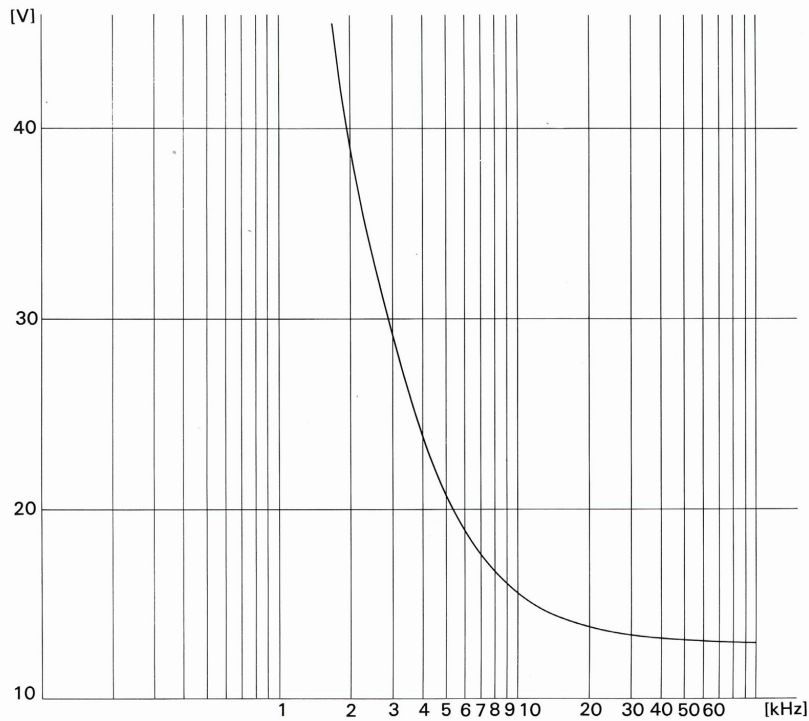


Fig. 18 Threshold level VS output frequency

### 2-1 Maintaining $V_H$ by HIGH-ON circuit

After HIGH-ON circuit is activated, the  $V_H$  level is maintained for (B) msec by the RC time constant to prevent the transistors from misoperating and from generating  $V_L$ - $V_H$  switching noise in the high frequency range. (Ref Fig. 15) The voltage readings of the circuit when it is working have

been indicated in Fig. 17. The potential at (C) drops gradually as shown in Fig. 18 with the help of the time constant of R59 and C16.  $V_H$  is maintained until C16 discharges and the potential at (C) becomes 9.46 V. Then, Q23 turns on. In this case, the period is 2.04 msec Fig. 19-b.

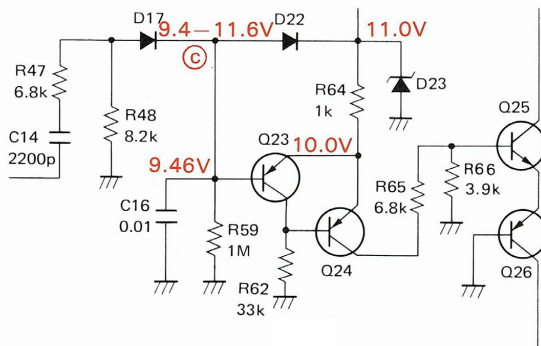


Fig. 19-a HIGH-ON circuit

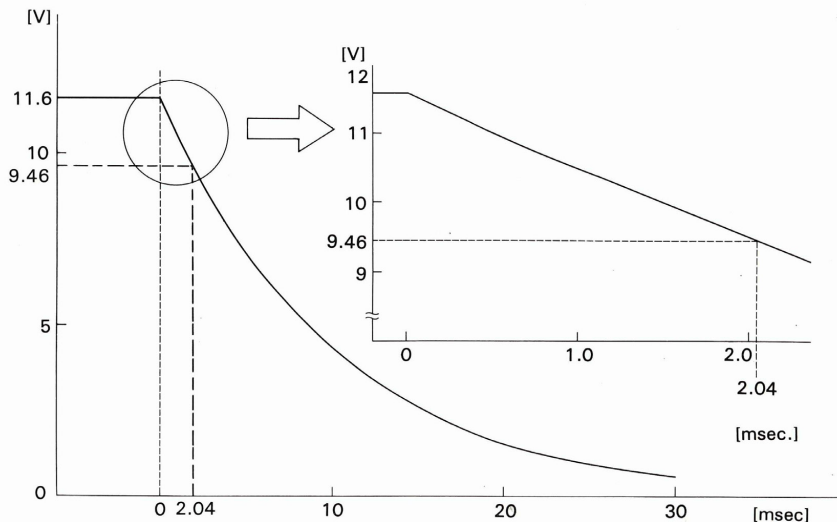


Fig. 19-b Discharging characteristic

D22 bypasses the current and avoids excessive reverse voltage and protects Q23. D23 keeps Q23's  $V_E$  constant. In A-80, it is held at 11 V.

## 2-2 Function of each component in HIGH-ON circuit

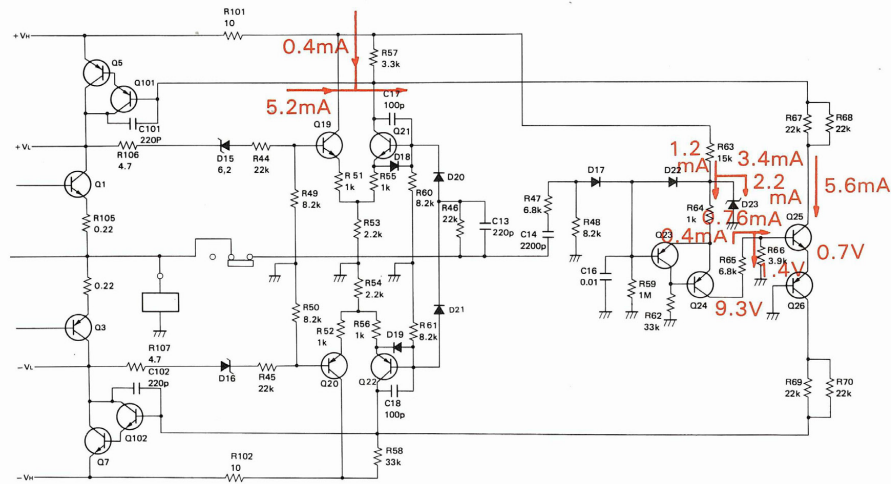


Fig. 20 Voltage and current in HIGH-ON circuit

- R63 (15 kΩ)

To make the operation of Q23 stable, its  $V_E$  is made constant by D23 zener diode. R63 determines the zener current (about 3 mA).

- R65, (6.8 kΩ), R66, (3.9 kΩ)

These resistors divide the current from Q24 to obtain the optimum base current ( $I_B$ ) of Q25 (about 0.7 mA) to switch it. The resistance values have been determined by taking the rising time of the Q25's switching operation into consideration.

- R67 (22 kΩ)//R68 (22 kΩ), R69 (22 kΩ)//R70 (22 kΩ)

When the output is high, Q5 turns on, and  $V_a$  rises as  $V_o$  rises. Q5's  $V_{CE}$  decreases down to the Saturation Range A in Fig. 21 because  $V_H$  is fixed. Here, if the Darlington-connected Q5 and Q101 are considered to be one transistor,  $Q_a$ ,  $Q_a$ 's  $h_{fe}$  becomes extremely low in the Range A. ( $h_{fe}$ : 4200 at (B) and 420 at (C)). To drive  $Q_a$  with its collector current of 2.1 A, the required base current is 5 mA when  $V_{CE}$  is in the middle of the Range A and only 0.5 mA when  $V_{CE}$  is -2 V. Usually, Q101 can be driven with the base current around 0.2 — 0.3 mA. The values of the resistors are determined so as to make the combined resistance become 11 kΩ to have the collector current of 5 mA lest  $V_{CE}$  should decrease and come into the Range A. They are connected in parallel to allow enough current.

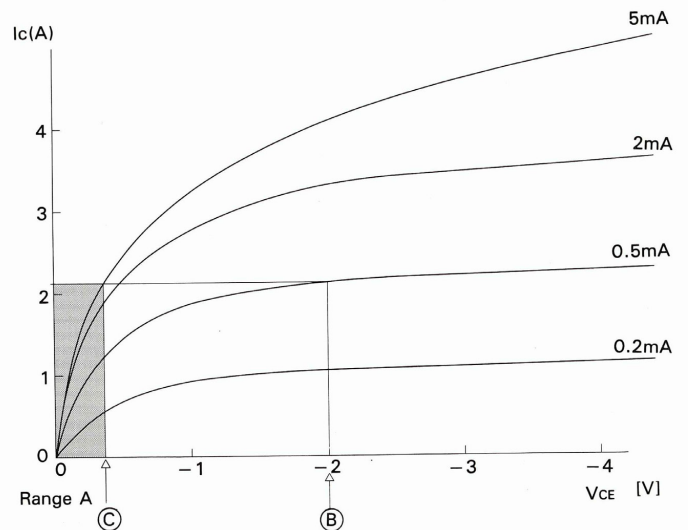


Fig. 21  $V_{CE}$ - $I_c$  characteristic

### III. TROUBLESHOOTING

As explained, the DPS amplifier is highly efficient because it is usually driven by a low voltage supply and is driven by a high voltage supply only when the input signal is high. The DPS circuit seems to be complicated because the dual power supply circuit is closely related to the power amplifier block. However, the power amplifier and power supply circuits are basically the same as the conventional ones.

Here, we will discuss the troubleshooting method of DPS.

#### 1. Diagnosis and Points to Be Checked

DPS consists of two blocks, the differential amplifier and the HIGH-ON circuit. The DPS amplifier seems to be normal when the power amplifier block is all right and the DPS block is faulty. The symptoms peculiar to faulty DPS circuits such as "Rated output is unobtainable," "Output distorts at a high level," and "Low efficiency" can be confirmed by applying a large input signal.

**1-1** Keep the impedance selector on the rear panel of the amplifier at 6–16Ω. DPS is open when the switch is turned to 4–6Ω.

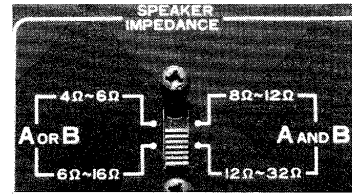


Photo 2 Speaker impedance selector

**Note:** When you connect 4Ω speakers to the amplifier, turn the switch to 4–6Ω. VL power supply is enough to obtain rated output when 4Ω speakers are connected. At this time, avoid selecting the 8–16Ω range to protect the power supply circuit. Increasing power output by connecting 4Ω speakers and selecting the 8–16Ω range is impossible because the current capacity of the power supply circuit is limited.

**1-2** The differential and HIGH-ON circuits can be inspected by observing the voltage at the collector of power transistors and at the speaker terminals on an oscilloscope. Fig. 22.

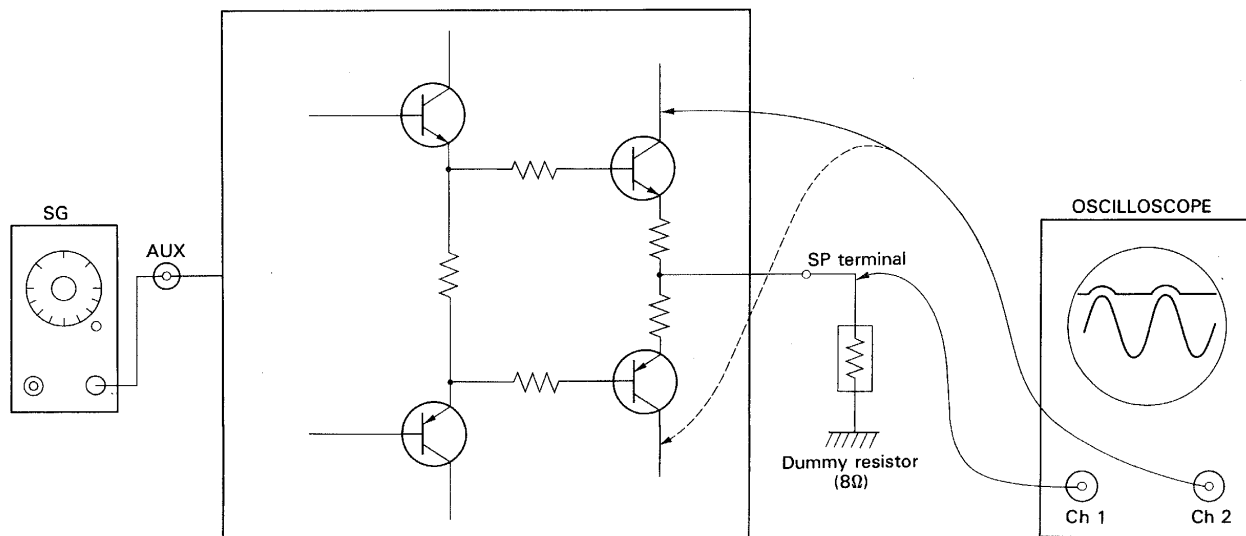


Fig. 22 Inspecting Differential and HIGH-ON circuits

- a) The differential amplifier can be checked by applying an input signal lower than 2kHz because the HIGH-ON circuit becomes active when the frequency is more than 2kHz.

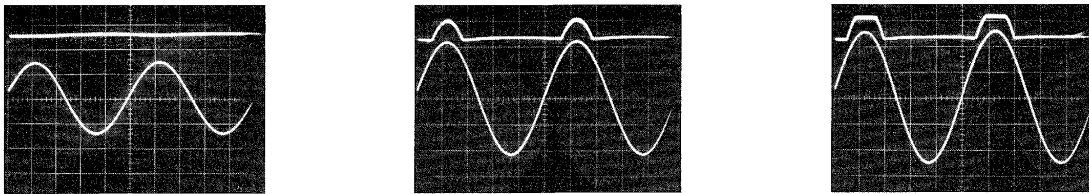


Photo 3 Supply voltage made by Differential Detector

- b) The HIGH-ON circuit can be checked by setting the input frequency higher than 5kHz because at this frequency the circuit starts working earlier than Differential circuit when the input level is gradually increased.

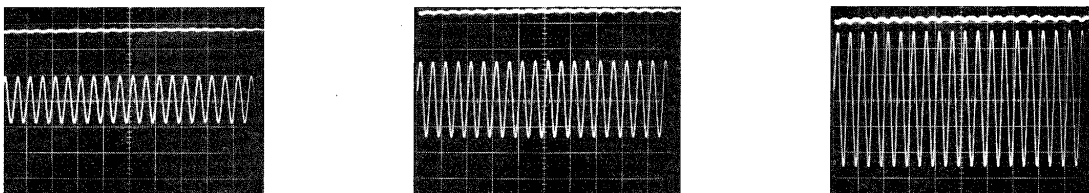


Photo 4 Operation of HIGH-ON circuit

- c) Both circuits can be checked with an input signal in the range from 2.1kHz to 2.6kHz because the differential circuit starts working earlier than the HIGH-ON circuit when the input level is gradually increased in this frequency range.

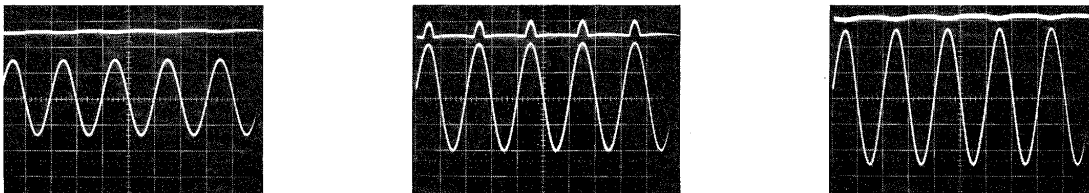


Photo 5 Operation of Differential circuit and HIGH-ON circuit

**Note:** HIGH-ON circuit

You may wonder why the HIGH-ON circuit responds not only to a high frequency but also to a high level, and both circuits can be turned on and off separately by selecting the input frequency and varying the input level. The HIGH-ON circuit passes high frequency signal components with a high-pass filter (HPF), rectifies them and then compares the rectified level with a reference level. So, it works when

the signal is large even when the frequency is comparatively low. But the circuit does not respond to signals of 2kHz or lower even if their level is high because the HPF blocks them. Thus, the above methods becomes possible. The waveforms on the positive side only have been shown. Those on the negative side are the same as above.

## 2. Cause and Effect

Let's see the cause and effect of the flowchart of DPS.

### 2-1 $V_a$ stays at $V_L$ .

a) Q101 (102) and/or Q5 (7) open

If Q101 opens ①, no bias voltage is applied to Q5 ②, Q5 stays off, no  $V_H$  power is supplied to  $V_a$  ③, and  $V_a$  stays at  $V_L$ .

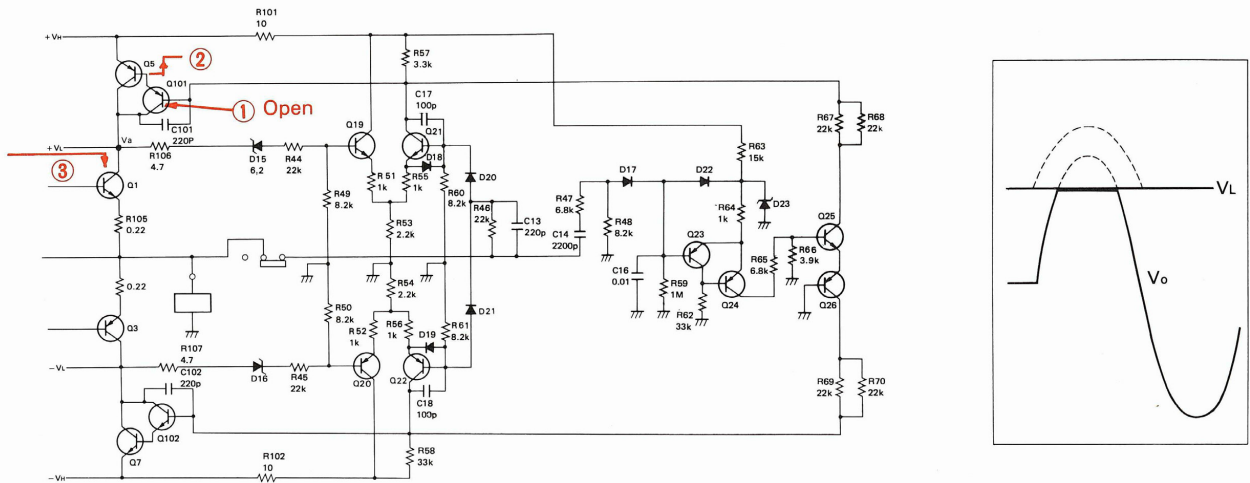


Fig. 23  $V_o$  is clipped when Q101 opens

b) Impedance Switch set on 4–6 $\Omega$  side (with 8–16 $\Omega$  speakers connected)

In A-60 and A-80, when the impedance switch is on the 4–6 $\Omega$  side, the output signal current to the DPS circuit is blocked by the impedance switch. Then, DPS circuit stays inactive and  $V_a$  is kept at  $V_L$ . In the case of A-70 and A-90, the impedance switch does not switch the DPS loop at its input but does it at its output with a Darlington circuit switching transistor. When the switch is turned to the

4–6 $\Omega$  side, it makes the  $V_B$  of the switching transistor fall. The transistor's  $V_{BE}$  increases. It turns on. The  $V_{EB}$ s of Q101 and Q5 decrease. They turn off and block  $V_H$  supply.

c) Darlington circuit switching transistor shorted (For A-70 and A-90)

When the switching transistor is shorted, the result is the same as the above.  $V_a$  stays at  $V_L$ .

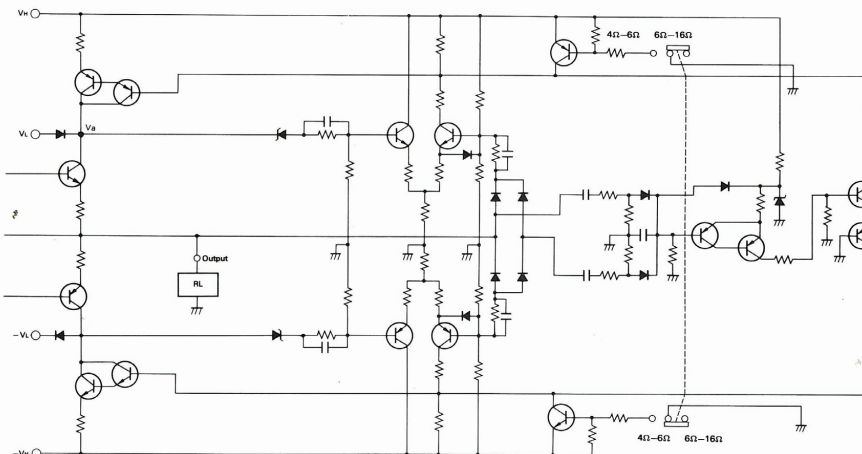
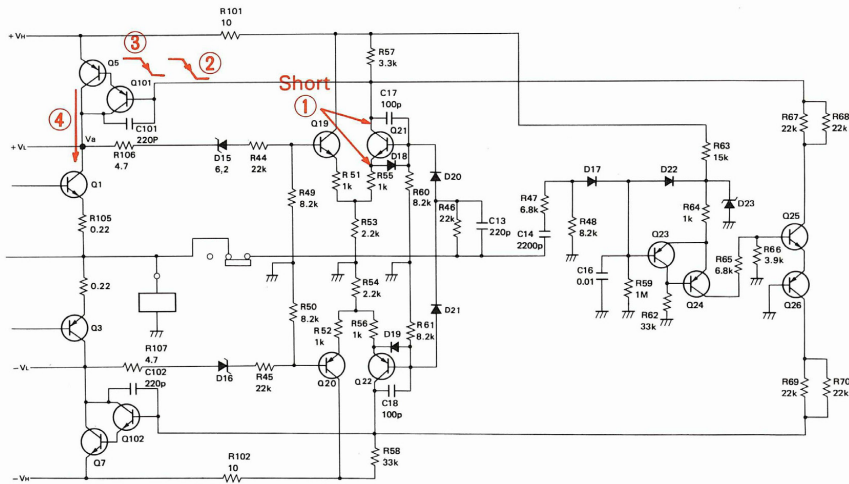


Fig. 24 A-70 Dynamic power supply circuit

**2-2 Va stays at VH all the time.**

a) R101(102), open. Q101(102), Q5(7), and/or Q21(Q22), CE short-circuited (VH on one side)

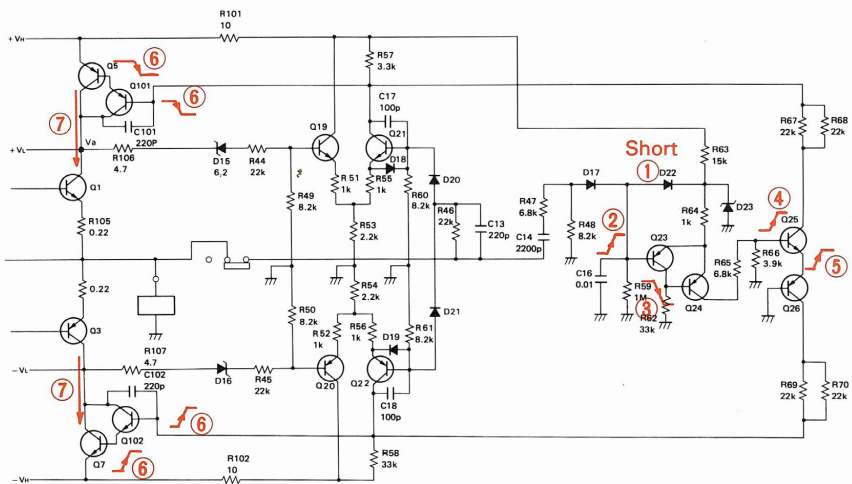
- If Q21CE shorts ①, Q101's VB falls ②, Q101 turns on, Q5's VEB increases, Q5 turns on ③ and Va becomes VH ④.
- If Q101CE shorts, Q5's VEB increases, Q5 turns on ③, and Va shifts to VH ④.
- If Q5CE shorts, the VH line is directly connected to the power transistor.
- If R101 opens, Q101's VB falls ② Q101 turns on. Q5 turns on ③. Va shifts to VH ④.



**Fig. 25**

b) Q23CE open, D22 short-circuited, Q24, Q25 and Q26 CE short-circuited (VH on both sides)

- If D22 is short-circuited ①, Q23's VB rises ②, Q23 turns off, Q24's VB falls ③, Q24 turns on, Q25's VB rises ④, Q25 turns on, Q26's VE rises ⑤, Q26 turns on, Q101, Q5, Q102, Q7 turn on ⑥, and Va becomes VH ⑦.
- If Q23c opens, Q24's VB falls ③, the result is the same as above ⑦.
- If Q25CE is short-circuited, the result is the same as when Q25 turns on: Q26's VE rises ⑤, and Va becomes VH ⑦.
- If Q26CE is short-circuited, Q25's VE falls, its VBE increases, Q25 turns on, Q101, Q5, Q102, and Q7 turn on ⑥, and Va becomes VH ⑦.



**Fig. 26**

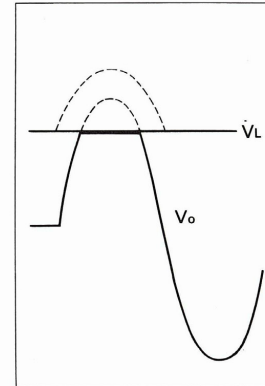
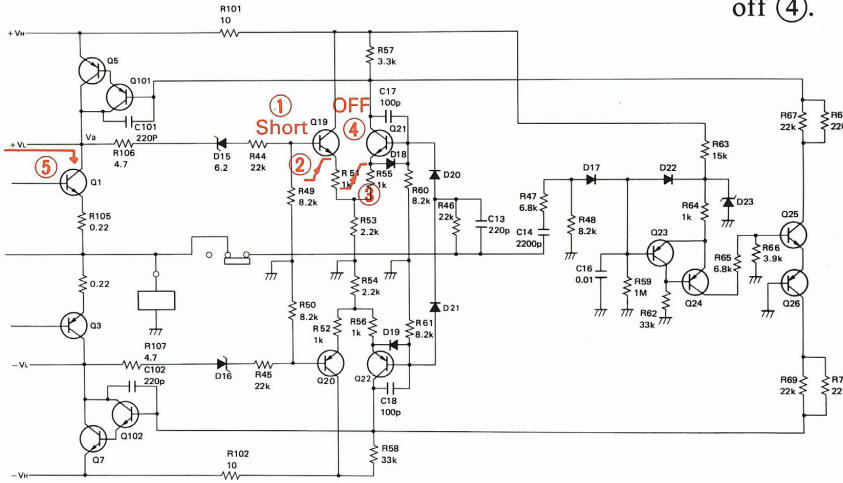


**2-3 Differential Detector is inactive ( $V_a$  stays at  $V_L$ ).**

*D18 (19) short-circuited, Q19 (20) CE short-circuited, Q21 (22) open*

- If Q19 short-circuits (1), Q19  $V_E$  rises (2), Q21  $V_E$  rises (3), and Q21 stays off because Q21  $V_B$  does not rise enough to turn it on (4). The differential amplifier stays inactive (5).

- If D18 short-circuits, Q21  $V_{BE}$  becomes 0 V, Q21 stays off (4), the Differential Detector is inactive,  $V_a$  stays at  $V_L$  (5).
- If Q21 is open, the result is the same as when Q21 is turned off (4).

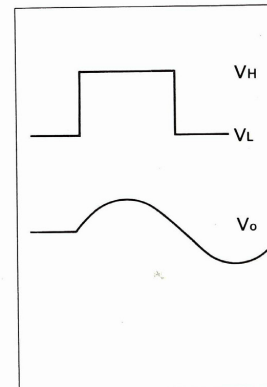
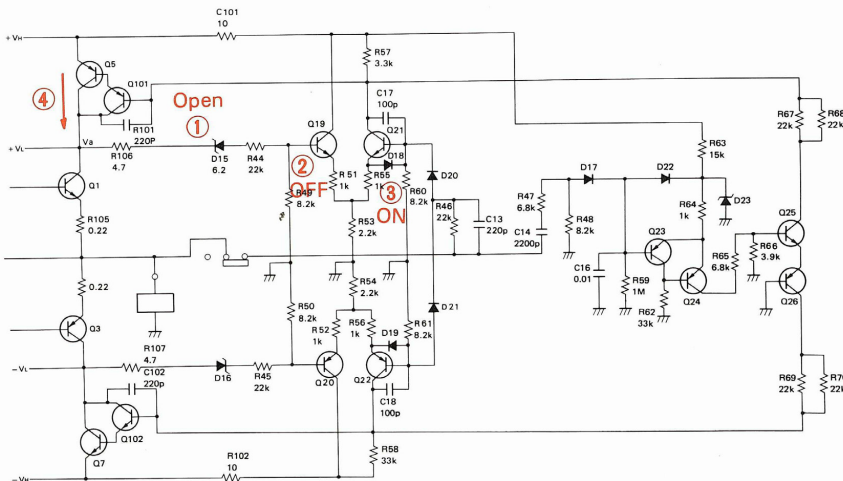


**Fig. 27**

**2-4 The HIGH-ON circuit starts working although the frequency and level of the input signal are low.**

*D15 (16), Q19 (20) open*

- If D15 opens (1), no  $V_a$  signal is applied to Q19. Q19 turns off (2), Q21 turns on (3), Q101 and Q5 turn on, and  $V_a$  becomes  $V_H$  (4). At this time, the differential amplifier only works as a switch.
- If Q19 opens, the result is the same as when Q19 turns off (2).



**Fig. 28**

**2-5 By-running  $V_a$  is not high enough in the range where the Differential Detector works.**

*D15 (16) short-circuited*

The difference ( $V_d$ ) between the output voltage ( $V_o$ ) and by-runner ( $V_a$ ) depends on the difference of the base potential of Q19 and Q21, the zener voltage across D15 and the rate of the resistance of R44 to that of R49. If D15 is short-circuited,  $V_d$  will lose the zener voltage.

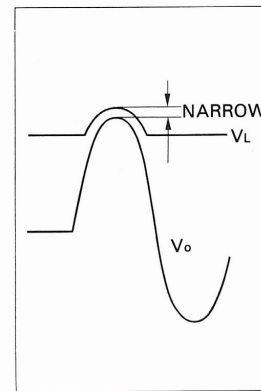


Fig. 29

**2-6 In the high frequency range, the HIGH-ON circuit is inactive but the Differential Detector is working.**

*Q24, Q25, Q26, and/or D23 open*

*D23, and/or Q23<sub>CE</sub> short-circuited*

- If Q25 opens,  $V_{BE}$  of Q101 and Q102 will decrease and  $V_H$  will be blocked.
- If Q26 opens, the result is the same as above because Q26 is in series to Q25.
- If D23 is short-circuited, Q24's  $V_{BE}$  drops, Q24, Q25 and Q26 turn off.

- If D23 opens, Q23's  $V_E$  rises, Q23 stays on. Q24, Q25 and Q26 stays off.
- If Q24 opens, Q25's  $V_B$  drops, and Q25 and Q26 turns off.
- If Q23 is short-circuited, Q24's  $V_{BE}$  becomes 0 V. Then Q24 turns off. Q25 and Q26 turn off.

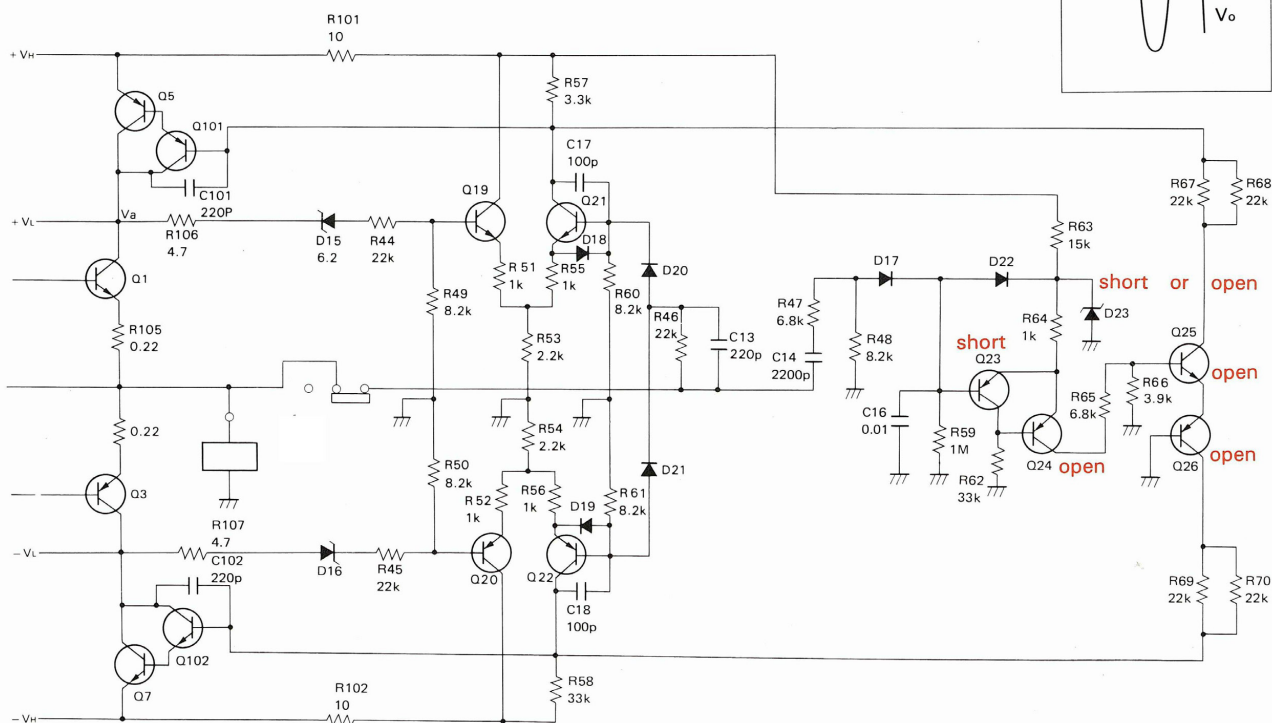
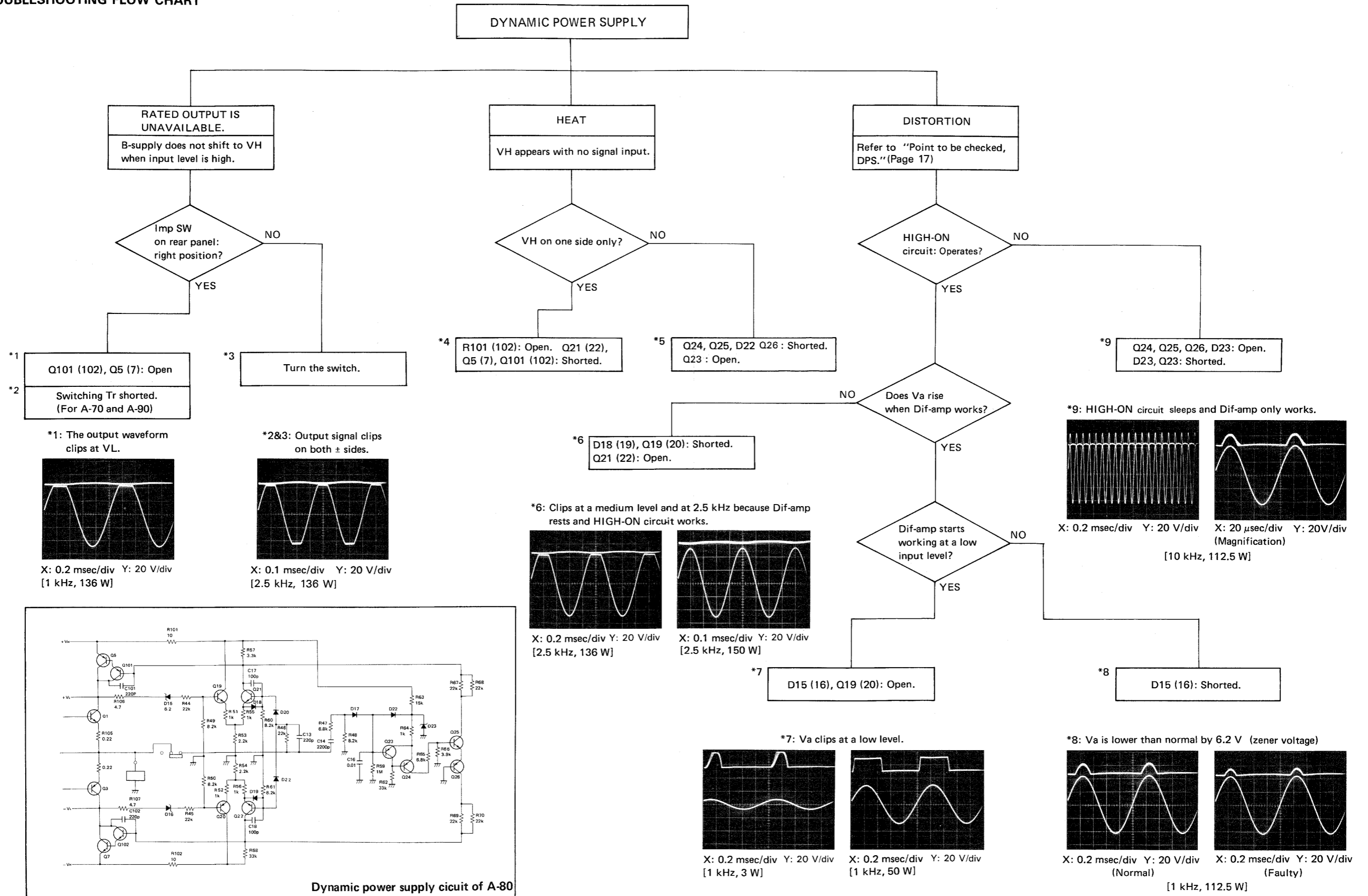


Fig. 30

### 3. TROUBLESHOOTING FLOW CHART



# MEMO

# MEMO

## IV. FET BUFFER CIRCUIT (A-90)

Here, we will discuss A-90. A-90 employs an FET buffer circuit to get a high output with low distortion. Generally, amplifiers have pre-drivers to increase their gain, and the gain varies depending on the load impedance. The gain is determined by the combined impedance of the parallel circuits of the pre-driver's load and the input of the next power amplifier stage.

The gain and the load impedance can be obtained with the following equations:

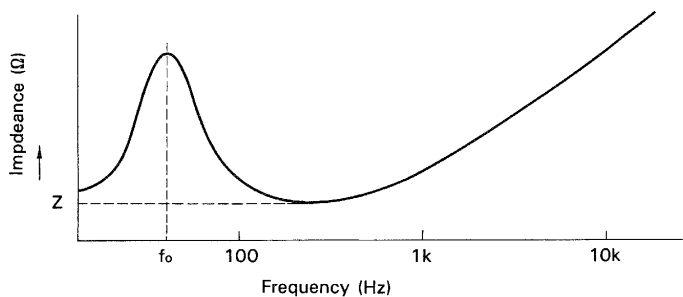
$$A_{v1} = (RL1/R_e)hfe, \quad RL = Z_{out}/(hfe1 \times hfe2 \times RL)$$

$R_e$ : Emitter resistor of pre-driver

$hfe1$ : Pre-driver's AC amplification

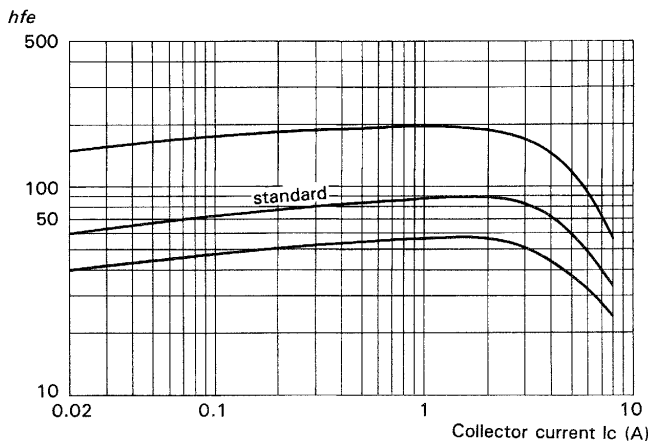
$hfe2$ : Power-transistor's AC amplification

$RL$ : Speaker load



**Fig. 31 Impedance characteristic of a bass reflex type speaker system**

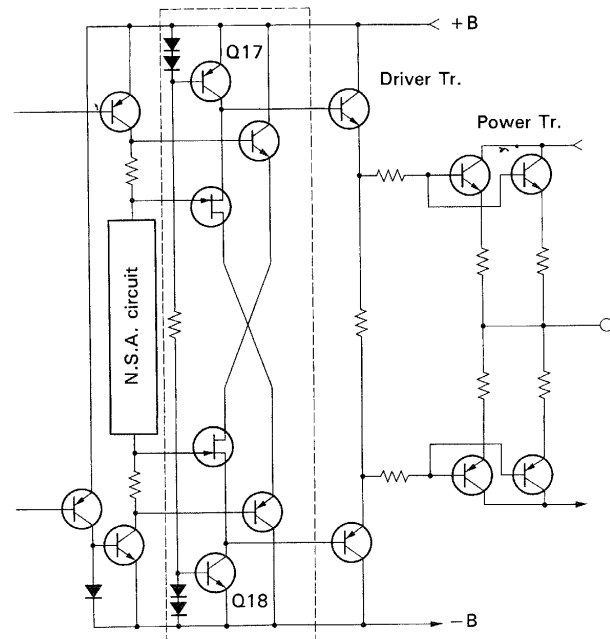
$Z_{out}$  of the predriver is usually very high because of a constant current load. The input impedance of the next stage, however, varies because it is affected by the non-linear characteristics of speaker impedance and the  $hfe$  of the power transistors shown in Figs. 31 and 32. Then, the total gain varies and distortion is increased.



**Fig. 32  $hfe$  versus  $I_c$  characteristic**

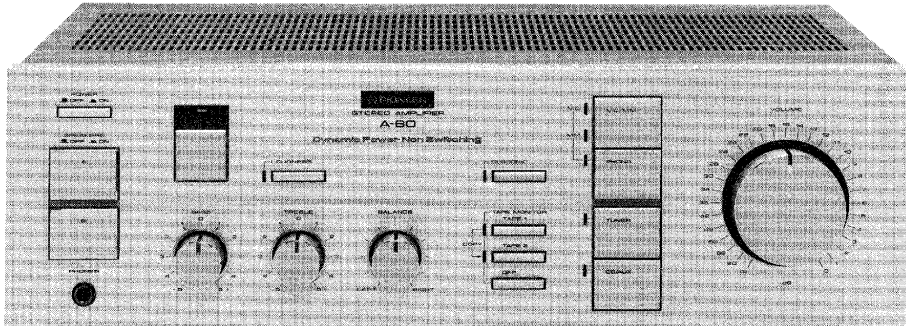
A-90 employs FETs of source-follower connection between pre-driver and power stages as buffers. The input impedance of FET is logically infinite and its output impedance is low. The pre-driver can be operated under stable condition with the high impedance load connected which keeps the pre-driver free from the variation of the speaker load and the  $hfe$  of the power transistors. Further, the low output impedance of the buffer makes the operation of the power stage stable. FET is an ideal interface for amplifiers because:

- (1) The output stage can be driven by constant voltage in the linear  $hfe$  range, and thus distortion can be kept extremely low.
- (2) The feedback loop gain can be kept constant because it is not affected by inductive load even when the type and impedance of the load is changed.
- (3) The output impedance in the non-feedback period can be kept very low.
- (4) The frequency characteristic can be improved. Driving power transistors in high speed becomes possible because they are driven by the signal of extremely low impedance which minimizes the storage effect of the power transistors.
- (5) A high gain and low distortion can be achieved in the pre-driver stage because its load impedance is very high. When the voltage between drain and source ( $V_{DS}$ ) becomes excessive, gate current flows and causes distortion and noise. To avoid them, the  $V_{DS}$  of each FET is maintained low at 2 V by connecting Q17 and Q18 in cascade.

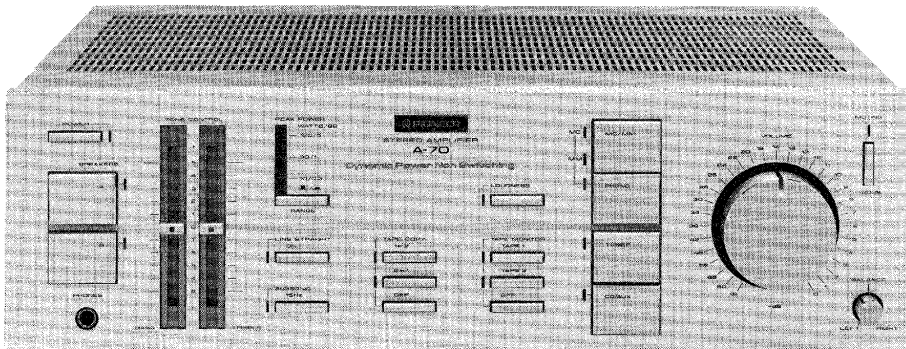


**Fig. 33 Buffer circuits in A-90**

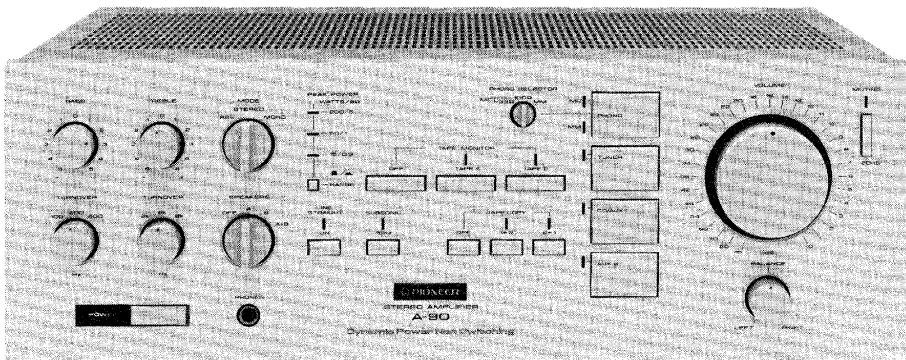
# NSA/DPS AMPLIFIERS



A-60



A-70



A-90

---

SERVICE GUIDE  
TROUBLESHOOTING POWER AMPLIFIERS  
— SUPPLEMENT TO TUNING FORK —

First printing: March 1984

Compiled and edited by  
Editor in Chief:  
**Ikki Nagashima**  
Administration Department  
International Division  
**Tadahiro Nakagawa**  
Service Section  
Administration Department  
International Division

and

Editors:  
**H. Abe**  
**H. Koike**  
**A. Kogirima**  
**S. Uchida**  
**K. Nohara**  
**S. Hirose**





**PIONEER ELECTRONIC CORPORATION**

4-1, Meguro 1-chome, Meguro-ku, Tokyo 153, Japan

**PIONEER ELECTRONICS (U.S.A.) INC.**

5000, Airport Plaza Drive, Long Beach, California 90815, U.S.A.

**PIONEER ELECTRONIC (EUROPE) N.V.**

Keetberglaan 1, 2740 Beveren, Belgium

**PIONEER ELECTRONICS AUSTRALIA PTY LTD.**

178-184 Boundary Road, Braeside, Victoria 3195, Australia