

Service Manual

PIONEER
The Art of Entertainment

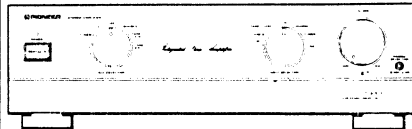

PION - 04672



ORDER NO.
ARP2728

STEREO AMPLIFIER

A - 400X

A - 400 X HAS THE FOLLOWING :

Type	Power Requirement	Remarks
HB	AC 220-230 V, 240 V (switchable)*	
YPW	AC 220-230 V, 240 V (switchable)*	
HL	AC 220-230 V, 240 V (switchable)*	

* Change the connection of the power transformer's primary wiring.

- This manual is applicable to A - 400 X/HB, YPW and HL types.
- For YPW and HL types, refer to page 18.

CONTENTS

1. EXPLODED VIEWS AND PARTS LIST	2
2. PACKING AND PARTS LIST	5
3. SCHEMATIC DIAGRAMS	6
4. PCB CONNECTION DIAGRAMS	9
5. PCB PARTS LIST	15
6. ADJUSTMENTS	17
7. FOR HL AND YPW TYPES	18
8. PANEL FACILITIES	19
9. SPECIFICATIONS	20

4672

1. EXPLODED VIEWS AND PARTS LIST

NOTES:

- Parts marked by "NSP" are generally unavailable because they are not in our Master Spare Parts List.
- The Δ mark found on some component parts indicates the importance of the safety factor of the part. Therefore, when replacing, be sure to use parts of identical designation.
- Parts marked by "●" are not always kept in stock. Their delivery time may be longer than usual or they may be unavailable.

Mark No.	Description	Parts No.	Mark No.	Description	Parts No.
1	ROTARY KNOB L (PLS)	AAB1160	46	S1 SWITCH	ASU1035
2	ROTARY KNOB R (PLS)	AAB1162		(INPUT SELECTOR)	
3	ROTARY KNOB M (PLS)	AAB1231	47	S2 SWITCH	ASU1037
4			(REC SELECTOR)	
5	KNOB (POWER)	AAD1535	Δ 48	T1 POWER TRANSFORMER	ATS1279
6	NAME PLATE (METAL)	AAM1058	49	AF COMPLEX ASS'Y	AWZ4961
7	SCREW	ABA-298	NSP 50	POWER SW ASS'Y	AWZ4964
8	SCREW (STEEL)	ABA1009	NSP 51	LED ASS'Y	AWZ4966
9	SCREW (STEEL)	ABA1011	NSP 52	SPACER	AEC1256
10	SCREW (STEEL)	ABA1016	53	EARTH SCREW	ABA1047
11	SCREW (STEEL)	ABA1048	NSP 54	FUSE CAUTION CARD	AAX-290
12	SCREW (STEEL)	ABA1050	55	BINDER	AEF1004
13	SCREW	ABA1082	56	BINDER	AEP-215
14	SPRING	ABH-052	57	
NSP 15	DIODE ASSY	AWZ4963	58	INSULATION RUBBER	AEZ1010
16		NSP 59	UL CAUTION CARD	AAX-313
17	RIVET	AEC-441	60	WASHER	ABE1018
18	SHEET	AEE1014	61	NUT	NK90FCU
19				
20	JOINT ARM	AMR2142			
21	PUSH KNOB	AAD1366			
NSP 22	TERMINAL SCREW	AKE-031			
23	PANEL BASE	AMB1651			
24	INDICATING LENS	AMR1160			
25	INSULATOR ASS'Y	AMR2140			
26				
NSP 27	CHASSIS	ANA1121			
28	FRONT PANEL	ANB1557			
29	REAR PANEL	ANC2084			
30	BONNET CASE	ANE1398			
NSP 31	BOTTOM PLATE	ANF1031			
32	1P AC INLET	AKP1115			
NSP 33	PCB HOLDER	ANG1442			
NSP 34	HEAT SINK	ANH1264			
35				
36	SCREW	BBT30P060FZK			
37	NUTS	NK90FZB			
38				
Δ 39	FU1 FUSE (T1.6A)	AEK-512			
Δ 40	Q1 TRANSISTOR	MSC3281			
Δ 41	Q2 TRANSISTOR	MSC3281			
Δ 42	Q3 TRANSISTOR	MSA1302			
Δ 43	Q4 TRANSISTOR	MSA1302			
Δ 44	Q5 TRANSISTOR	2SC4137			
Δ 45	Q6 TRANSISTOR	2SC4137			

C

D

E

F

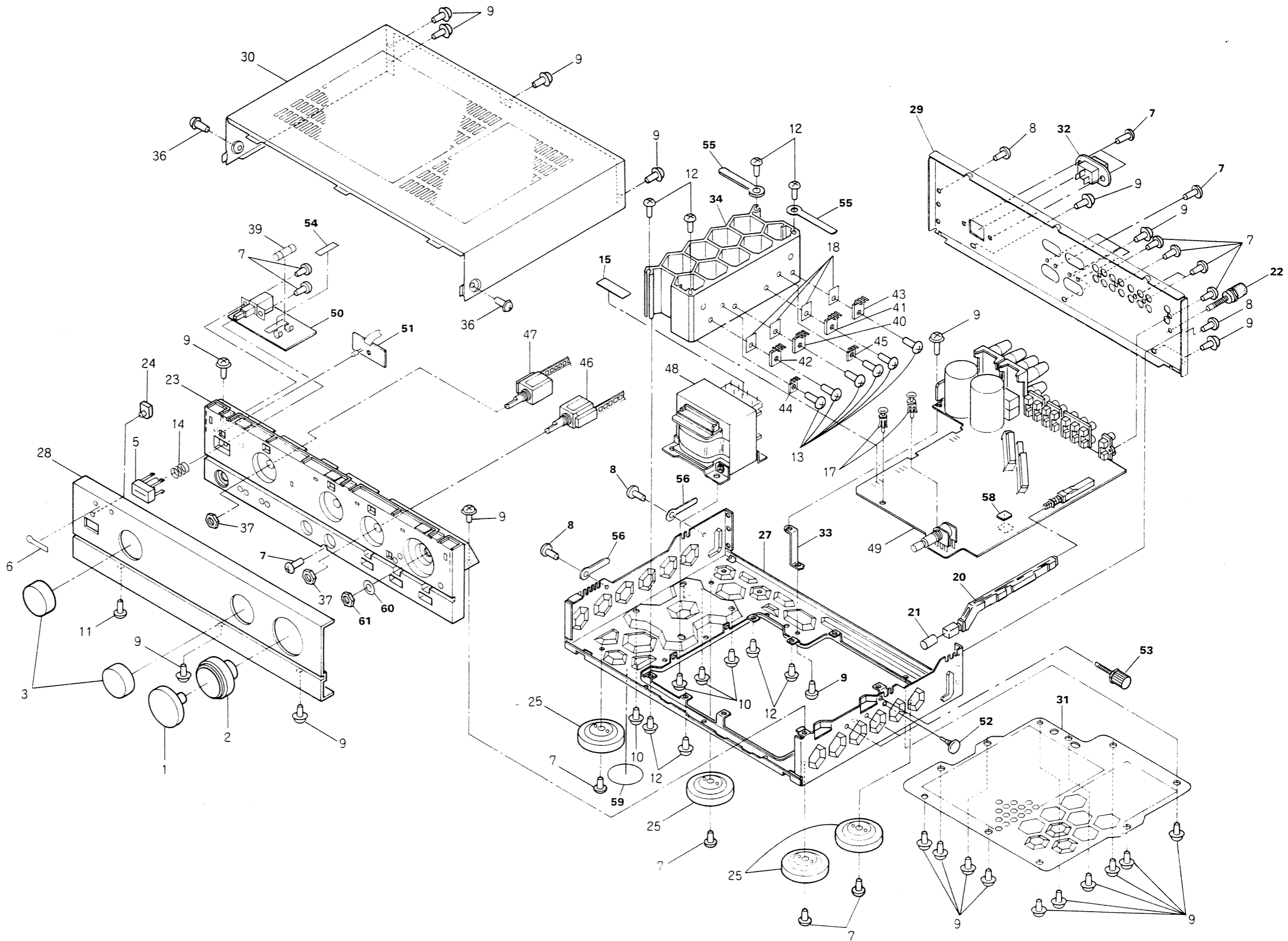

2. PACKING AND PARTS LIST

NOTES:

- Parts marked by "NSP" are generally unavailable because they are not in our Master Spare Parts List.
- The Δ mark found on some component parts indicates the importance of the safety factor of the part. Therefore, when replacing, be sure to use parts of identical designation.
- Parts marked by "⊙" are not always kept in stock. Their delivery time may be longer than usual or they may be unavailable.

Mark No.	Description	Parts No.
	1 REAR PAD	AHA1597
	2 FRONT PAD	AHA1596
	3 OPERATING INSTRUCTIONS (ENGLISH)	ARB1431
	4 PACKING CASE	AHD2546
NSP	5 PACKING SHEET	AHG1016
Δ	6 AC POWER CORD	ADG1136

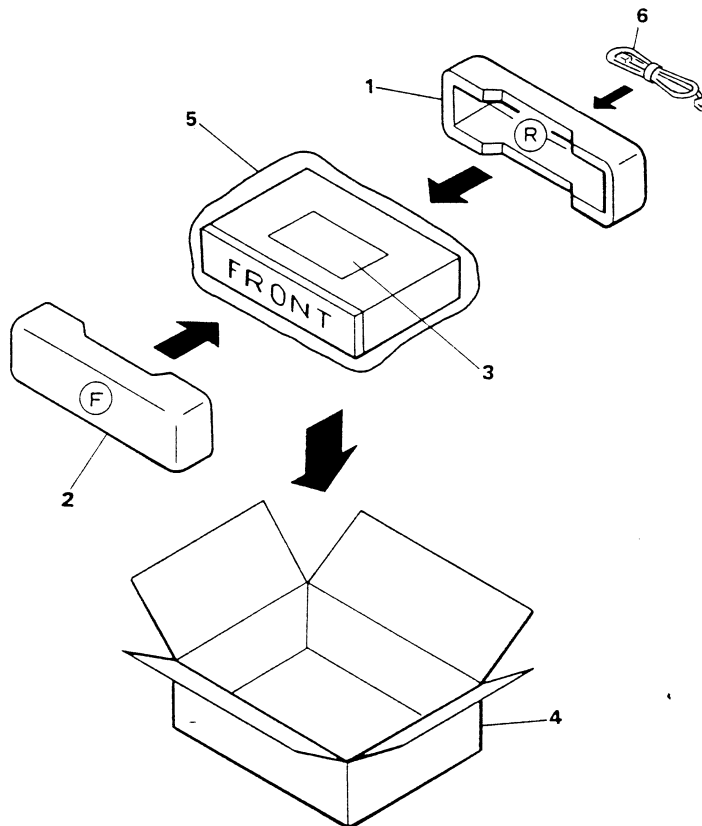

3. SCHEMATIC DIAGRAMS

A

AF COMPLEX ASS'Y (AWZ4961:HB TYPE)
(AWZ4962:HL AND YPW TYPES)

B
C
D
E
F

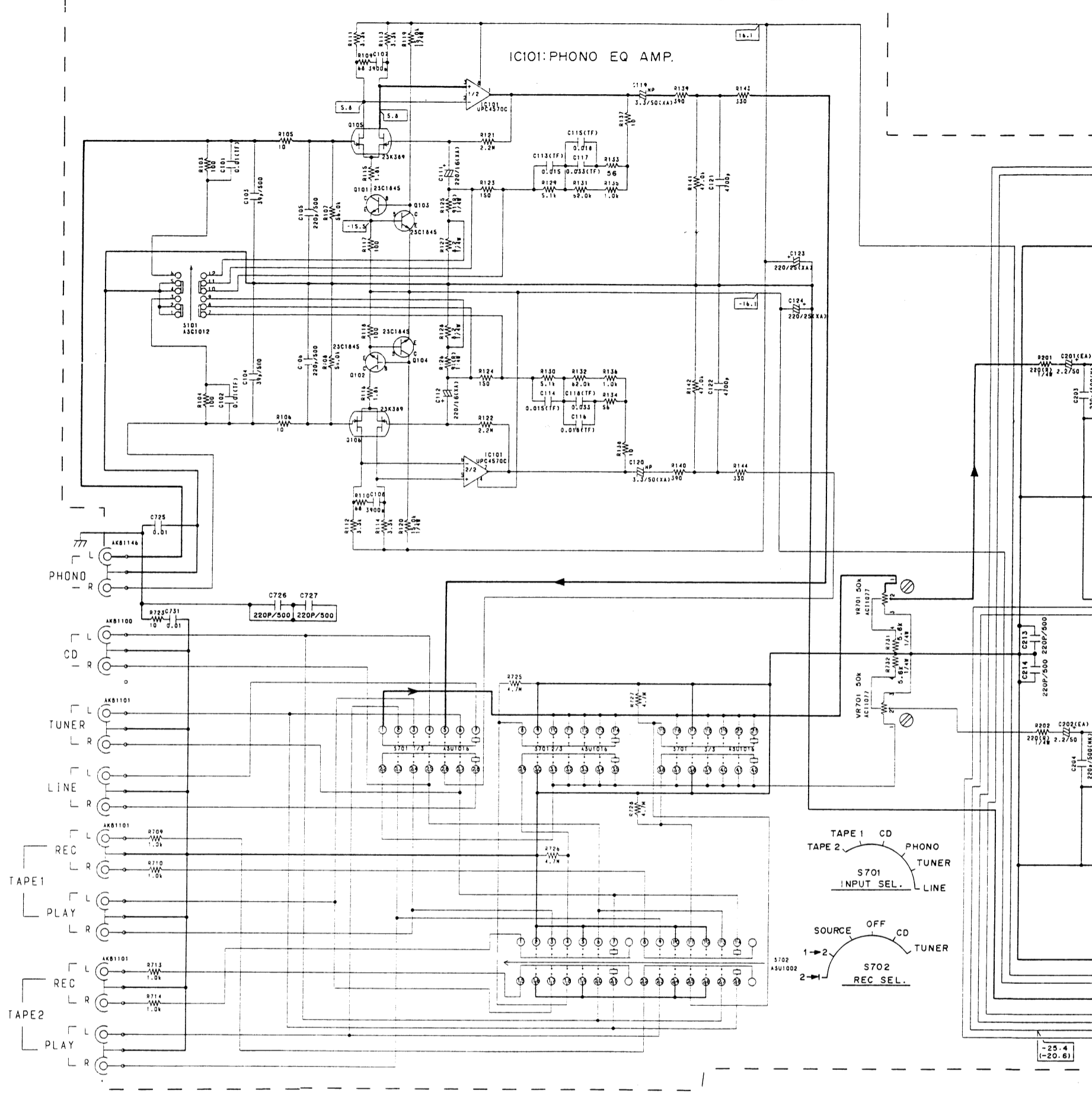

Note:

(Type 1)

1. When ordering service parts, be sure to refer to "PARTS LIST of EXPLODED VIEWS" or "PCB PARTS LIST".
2. Since these are basic circuits, some parts of them or the values of some components may be changed for improvement.
3. RESISTORS:
Unit: k: kΩ, M: MΩ, or Ω unless otherwise noted.
Rated power: 1/4W, 1/6W, 1/8W, 1/10W unless otherwise noted.
Tolerance: (F): ±1%, (G): ±2%, (K): ±10%, (M): ±20% or ±5% unless otherwise noted.
4. CAPACITORS:
Unit: p: pF or μF unless otherwise noted.
Ratings: capacitor (μF)/ voltage (V) unless otherwise noted.
Rated voltage: 50V except for electrolytic capacitors.
5. COILS:
Unit: m: mH or μH unless otherwise noted.
6. VOLTAGE AND CURRENT:

	: Signal voltage at rated output.
	: DC voltage (V) at no input signal unless otherwise noted.
	Value in () is DC voltage at rated power.
	: mA or - mA: DC current at no input signal unless otherwise noted.
7. OTHERS:
 - → : Signal route.
 - ⊗ : Adjusting point.
 - ▼ (Red) : Measurement point.
 - The Δ mark found on some component parts indicates the importance of the safety factor of the parts. Therefore, when replacing, be sure to use parts of identical designation.
8. SWITCHES (Underline indicates switch position):
 - S501 : POWER SW (ON - OFF)
 - S101 : PHONO SEL MM/MC
 - S701 : INPUT SEL (TAPE2 - TAPE1/DAT - CD - PHONO - TUNER - LINE)
 - S702 : REC SEL (2 → 1 - 1 → 2 - SOURCE - OFF - CD - TUNER)

:SIGNAL LINE

POWER AMP.

Q301, Q302: OVER LOAD DETECTOR
Q303, Q304: DC DETECTOR
Q305-Q307: PROTECTION

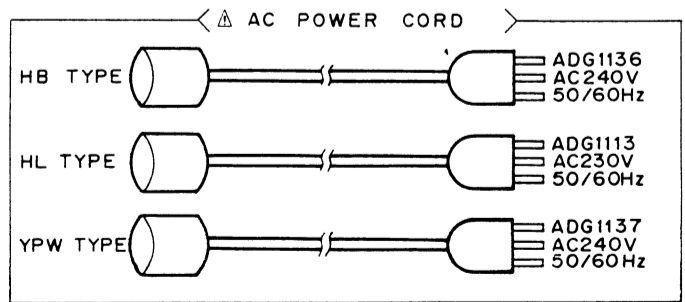
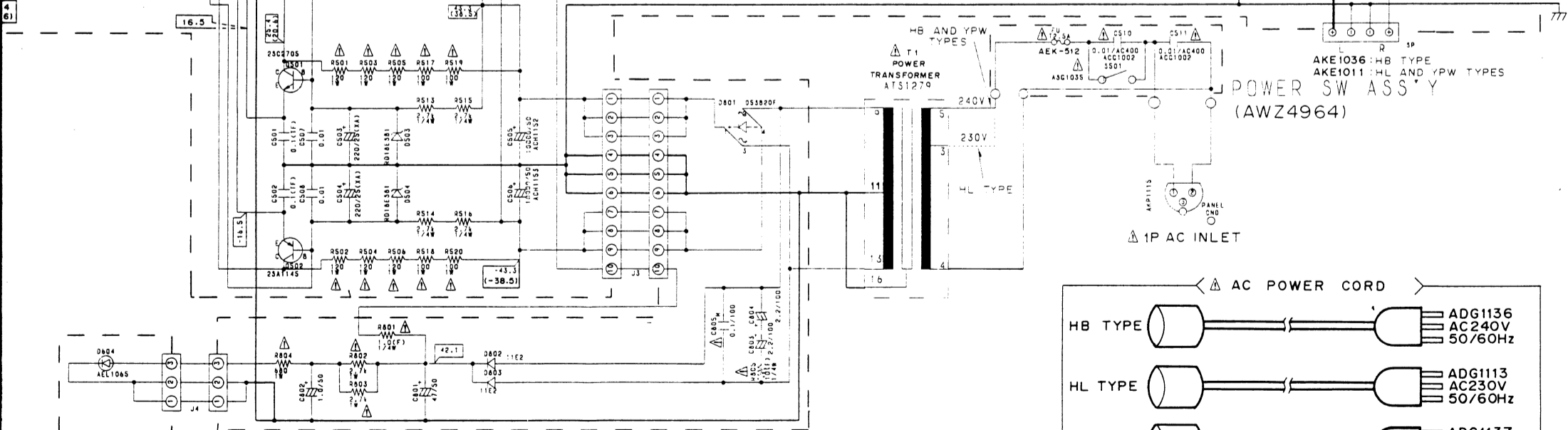
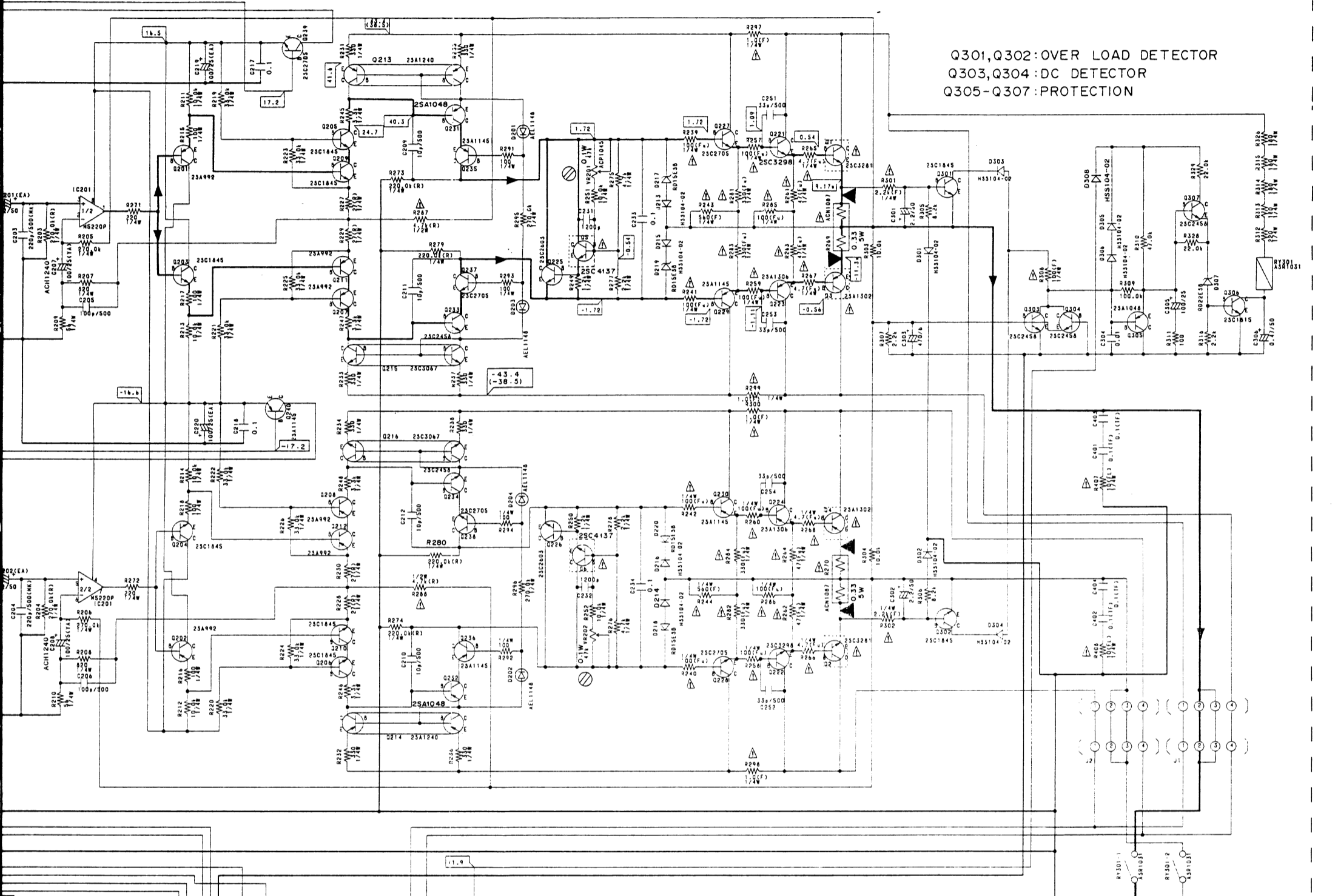

LED ASS'Y (AWZ4966)

DIODE ASS'Y (AWZ4963)

POWER SW ASS'Y (AWZ4964)

4. PCB CONNECTION DIAGRAMS

This P.C.B. connection diagram is viewed from the parts mounted side.

AF COMPLEX ASS'Y
(AWZ4961: HB TYPE)
(AWZ4962: HL AND YP

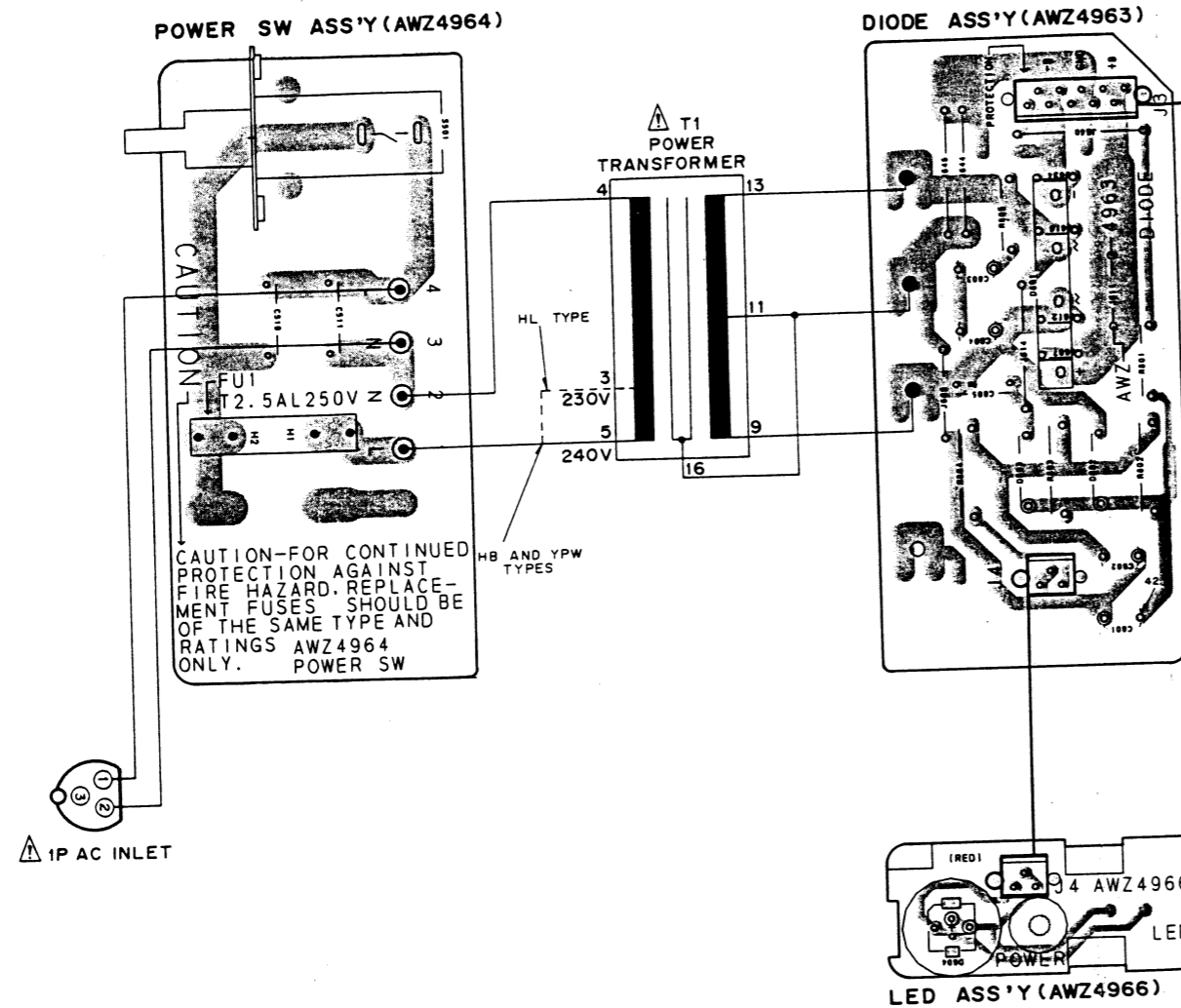

NOTE

1. This P.C.B. connection diagram is viewed from the parts mounted side.
2. The parts which have been mounted on the board can be replaced with those shown with the corresponding wiring symbols listed in the following Table.

P.C.B. pattern diagram indication	Corresponding part symbol	Part Name
		Transistor
		Radiator type transistor
		Diode
		Resistor
		Capacitor (Polarity)
		Capacitor (Non-polarity)

Others

P.C.B. pattern diagram indication	Part Name
IC	IC
S	Switch
RY	Relay
L	Coil
F	Filter
VR	Variable resistor or Semi-fixed resistor

3. The capacitor terminal marked with ⊙ (double circles) shows negative terminal.
4. The diode terminal marked with ⊙ (double circles) shows cathode side.
5. The transistor terminal to which E is affixed shows the emitter.

Line Voltage Selection

Line Voltage can be changed as follows :

1. Disconnect the AC power cord.
2. Remove the cover.
3. Change the connection of the power transformer primary taps.
4. Stick the line voltage label on the rear panel.

Part No.	Description
AAX - 193	220 V label
AAX - 192	240 V label

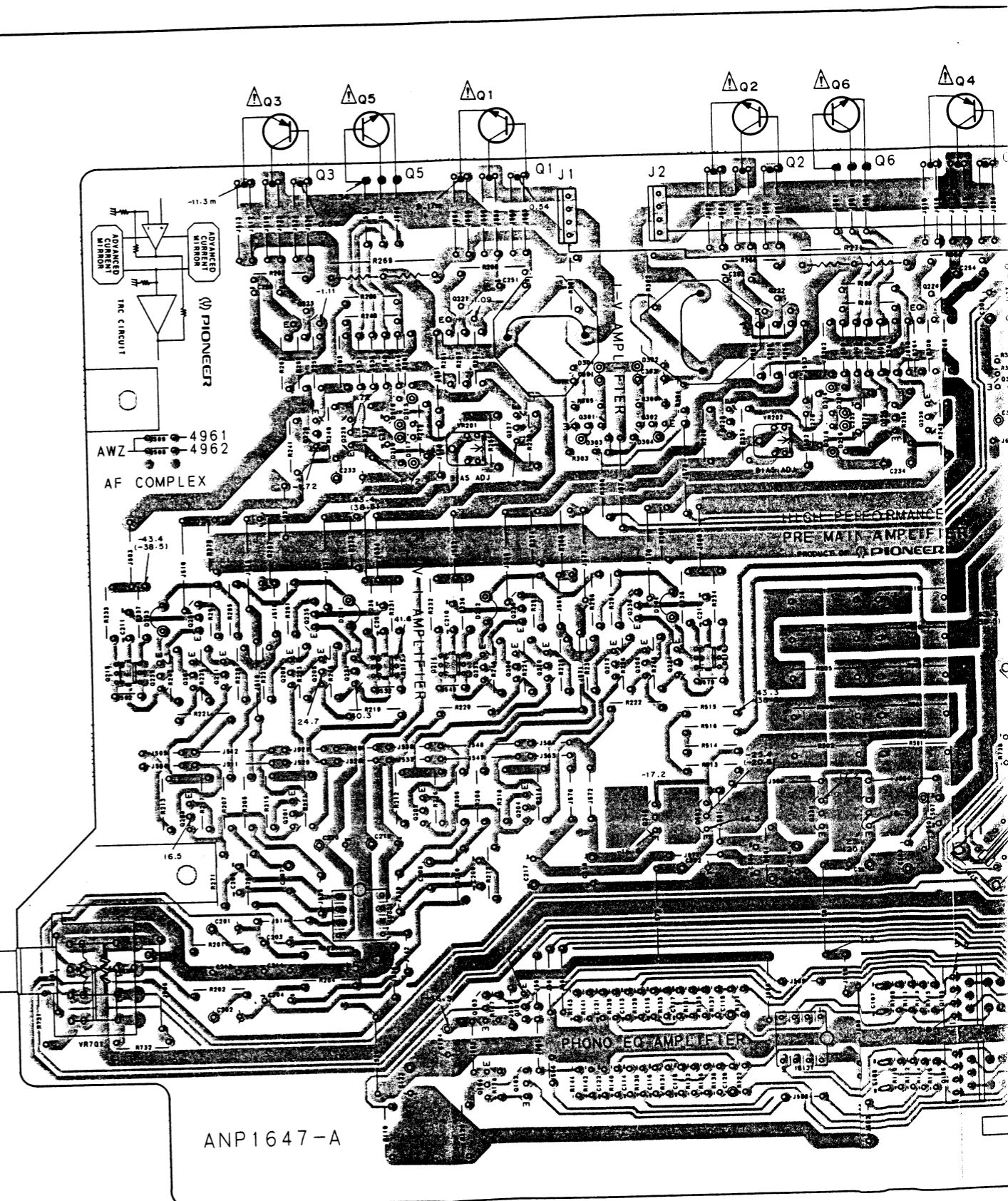

This P.C.B. connection diagram is viewed from the parts mounted side.

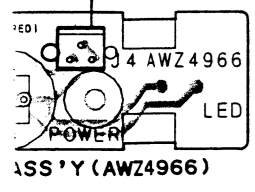
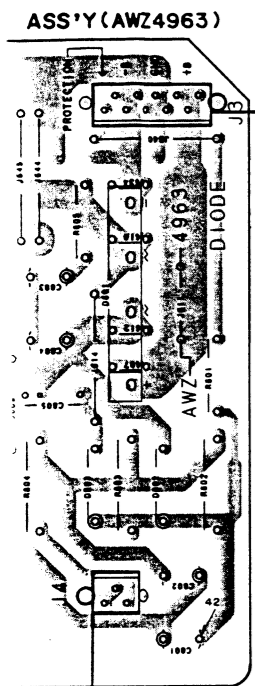

AF COMPLEX ASS'Y
(AWZ4961 : HB TYPE)
(AWZ4962 : HL AND YPW TYPES)

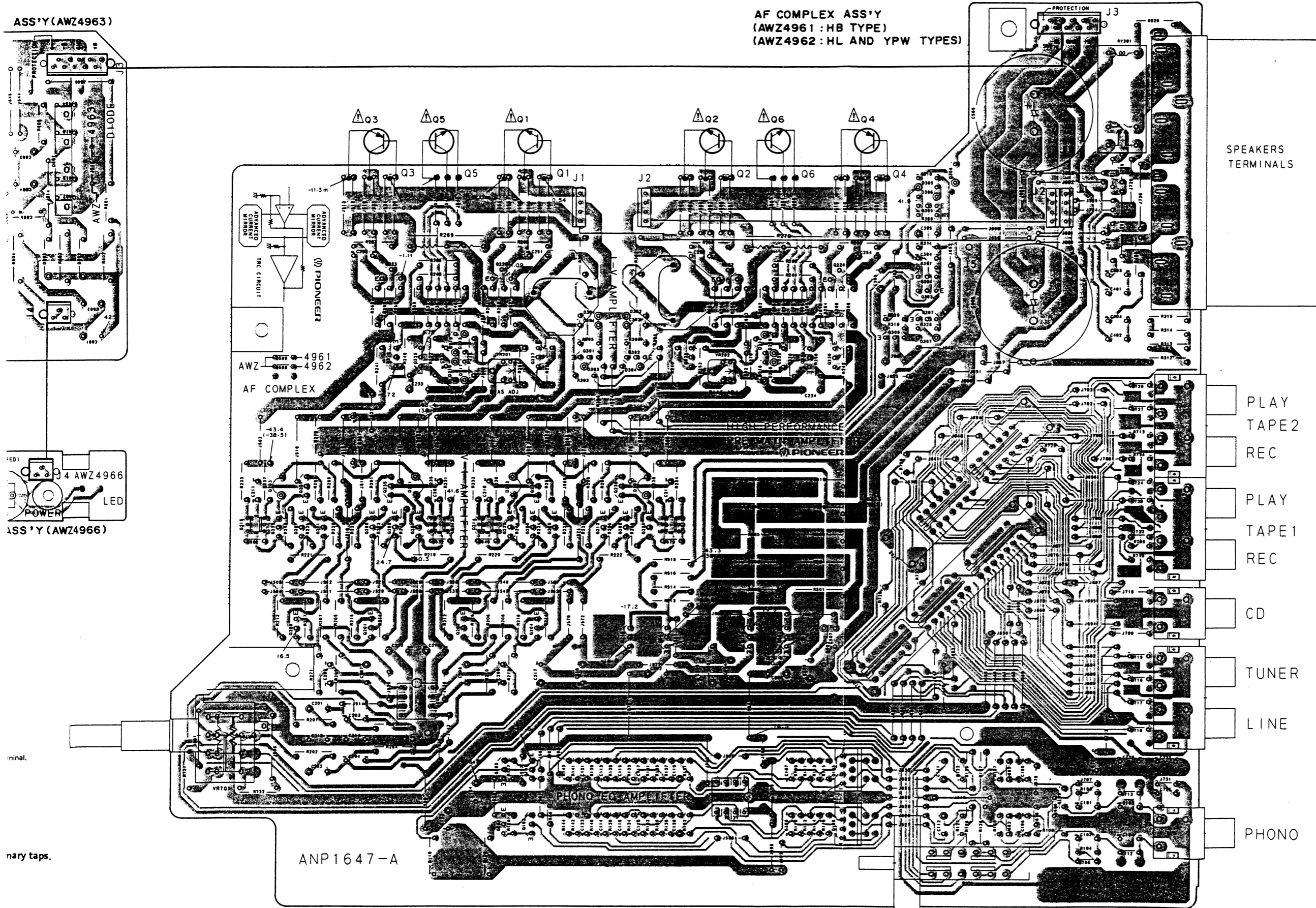

SPEAKERS
TERMINALS

PLAY
TAPE2
REC

PLAY
TAPE1
REC

CD

TUNER
LINE

PHONO

- Q305
- Q223 Q221 Q222 Q304
- Q224
- Q303
- Q307
- Q306
- Q229 Q225 Q301 Q302
- Q227 Q228 Q226 Q230
- VR201
- VR202

- Q237 Q235 Q236 Q238
- Q205 - Q216
- Q231 - Q234

- Q203 Q201 Q202 Q204
- Q240 Q502 Q239 Q501

- IC201
- VR701
- Q103 Q101 Q105
- IC101
- Q104 Q102 Q106

Primary taps.

ANP1647-A

5. PCB PARTS LIST

NOTES:

- Parts marked by "NSP" are generally unavailable because they are not in our Master Spare Parts List.
- The Δ mark found on some component parts indicates the importance of the safety factor of the part. Therefore, when replacing be sure to use parts of identical designation.
- Parts marked by "⊙" are not always kept in stock. Their delivery time may be longer than usual or they may be unavailable.
- When ordering resistors, first convert resistance values into code form as shown in the following examples.

Ex.1 When there are 2 effective digits (any digit apart from 0), such as 560 ohm and 47k ohm (tolerance is shown by J = 5% and K = 10%).

560Ω → 56 × 10¹ → 561 RD1/8PM $\overline{561}$ J
 47kΩ → 47 × 10³ → 473 RD1/4PS $\overline{473}$ J
 0.5Ω → 0R5 RN2H $\overline{0R5}$ K
 1Ω → 010 RS1P $\overline{010}$ K

Ex.2 When there are 3 effective digits (such as in high precision metal film resistors).
 5.62kΩ → 562 × 10¹ → 5621 RN1/4PC $\overline{5621}$ F

Mark No.	Description	Parts No.	Mark No.	Description	Parts No.
LIST OF ASSEMBLIES			CAPACITORS		
NSP	AF ASSY	AWK1711	C505	(10000/50V)	ACH1152
NSP	— AF COMPLEX ASSY	AWZ4961	C506	(10000/50V)	ACH1153
NSP	— DIODE ASSY	AWZ4963	C207,C208	(100/25V)	ACH1240
NSP	— POWER SW ASSY	AWZ4964	C209 - C212		CCCSL100D500
NSP	— LED ASSY	AWZ4966	C205,C206		CCCSL101K500
AF COMPLEX ASSY			C105,C106,C203,C204C213,C214, C726,C727		CCCSL221K500
SEMICONDUCTORS			C251 - C254		CCCSL330K500
IC201		M5220P	C103,C104		CCCSL390K500
IC101		UPC4570C	C305		CEAS101M25
Q231,Q232,Q305		2SA1048	C303		CEAS471M6
Q229,Q230,Q235,Q236,Q240, Q502		2SA1145	C306		CEASR47M50
Q213,Q214		2SA1240	C201,C202,C301,C302		CEEA2R2M50
Q223,Q224		2SA1306	C219,C220		CEXA101M25
Q201,Q202,Q207,Q208,Q211, Q212		2SA992	C123,C124,C503,C504		CEXA221M25
Q306		2SC1815	C119,C120		CEXANP3R3M50
Q101 - Q104,Q203 - Q206, Q209,Q210,Q301,Q302		2SC1845	C111,C112		CEYA221M16
Q233,Q234,Q303,Q304,Q307		2SC2458	C401 - C404		CFTXA104J50
Q225,Q226		2SC2603	C113,C114		CFTXA153J50
Q227,Q228,Q237 - Q239, Q501		2SC2705	C115,C116		CFTXA183J50
Q215,Q216		2SC3067	C117,C118		CFTXA333J50
Q221,Q222		2SC3298	C101,C102		CFTYA103J50
Q105,Q106		2SK389	C217,C218,C233,C234,C501,C502		CFTYA104J50
D201 - D204		AEL1148	C231,C232		CKCYB122K50
D213 - D216,D301 - D306, D308		HSS104 - 02	C107,C108		CKCYB392K50
D217 - D220		RD15ESB	C304,C507,C508,C725, C731		CKCYF103Z50
D503,D504		RD18ESB1	C121,C122		CQMA472J100
D307		RD22ESB			
SWITCHES					
S101		ASG1012			
S702		ASU1002			
S701		ASU1016			
RELAY					
RY301		ASR1031			

Mark No.	Description	Parts No.	Mark No.	Description	Parts No.
RESISTORS			CAPACITORS		
	VR201,VR202 (47K)	ACP1045		C802	CEAS010M50
	VR701 (50K-B1X2)	ACT1077		C803,C804	CEAS2R2M100
△	R269,R270 (0.33)	ACN1087		C801	CEAS470M50
	R215-R218,R291-R294	RD1/4PM101J	△	C805	CQMXA104J100
	R211-R214,R251,R252,	RD1/4PM103J			
	R731,R732	RDR1/4PM562J		RESISTORS	
	R249,R250	RD1/4PM122J	△	R801	RD1/4PMF010J
	R119,R120	RD1/4PM153J	△	R805	RD1/4PMF100J
	R313-R315,R326	RD1/4PM181J	△	R802,R803	RS1LMF272J
	R271,R272,R312	RD1/4PM221J	△	R804	RS1LMF681J
	R277,R278	RD1/4PM222J			
	R513-R516	RD1/4PM272J		POWER SW ASSY	
	R295,R296	RD1/4PM274J		SWITCHES	
	R231-R238	RD1/4PM331J	△	S501	ASG1035
	R245-R248	RD1/4PM332J			
	R219-R226	RD1/4PM333J		CAPACITORS	
	R275,R276	RD1/4PM472J	△	C510,C511 (0.01/AC400V)	ACG1002
	R209,R210	RD1/4PM560J			
	R207,R208	RD1/4PM821J		LED ASSY	
	R127,R128	RD1/4PM8R2J		SEMICONDUCTORS	
△	R297-R300	RD1/4PMF010J		D604	AEL1065
△	R308	RD1/4PMF101J			
△	R301,R302	RD1/4PMF222J			
△	R243,R244	RD1/4PMF561J			
△	R407,R408	RD1/4PMFL100J			
△	R287,R288	RDR1/2PM472J			
	R201,R202	RDR1/4PM221J			
	R273,R274,R279,R280	RDR1/4PM224J			
	R227-R230	RDR1/4PM270J			
	R203-R206	RDR1/4PM274J			
	R125,R126	RDR1/4PM910J			
△	R239-R242,R257-R260,R285, R286	RFA1/4PS101J			
△	R281-R284	RFA1/4PS331J			
△	R261-R264	RFA1/4PS470J			
△	R265-R268	RFA1/4PS4R7J			
△	R517-R520	RS1PMF101J			
△	R501-R506	RS1PMF121J			
	Other Resistors	RD1/8PM□□□J			
OTHERS					
	PIN JACK(2P)	AKB1100			
	PIN JACK(4P)	AKB1101			
CN	PIN JACK(2P)	AKB1146			
	SPEAKER TERMINAL 8-P	AKE1036			
DIODE ASSY					
SEMICONDUCTORS					
	D802,D803	11E2			
	D801	D5SB20F			

6. ADJUSTMENTS

ADJUSTMENT OF IDLE CURRENT

- 1. Connect wire as shown in Fig 6-1.
- 2. After power ON, aging lasts for 5 minutes with no-load.
- 3. In the Lch VR201 should be adjusted so that both terminal voltages of R269 may attain to 20 mV (± 3 mV).
- 4. In the Rch VR202 should be adjusted so that both terminal voltages of R270 may attain to 20 mV (± 3 mV).

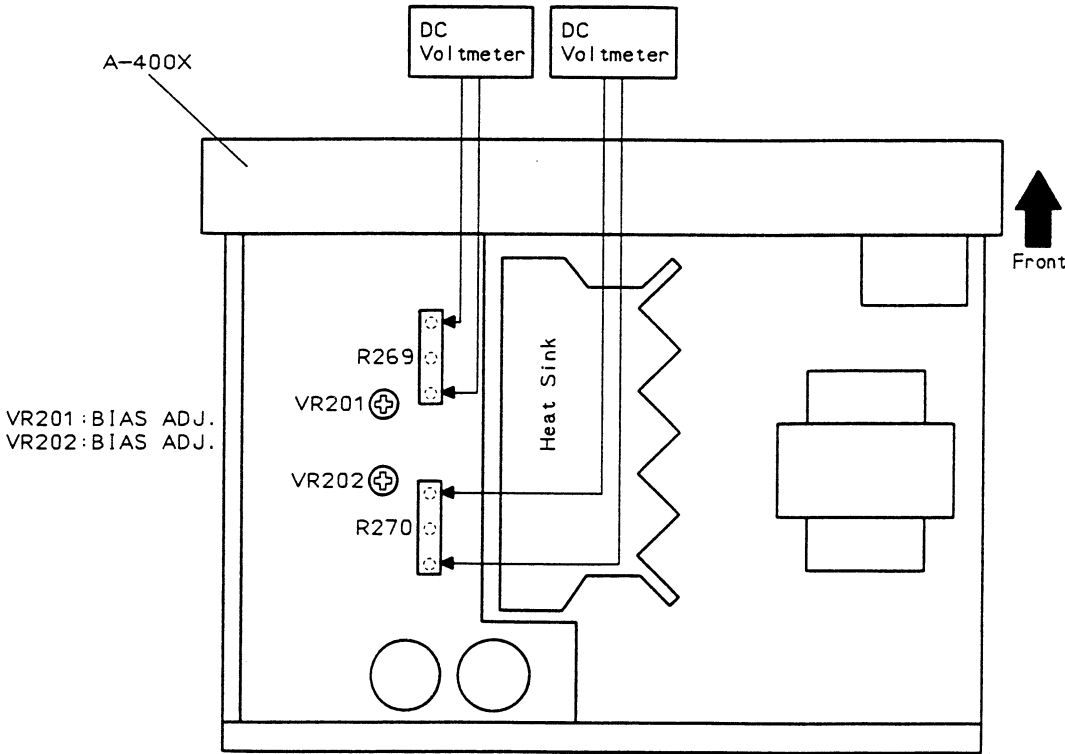

Fig. 6-1 Adjustment Drawing

7. FOR HL AND YPW TYPES

CONTRAST OF MISCELLANEOUS PARTS

NOTES:

- Parts marked by "NSP" are generally unavailable because they are not in our Master Spare Parts List.
- The Δ mark found on some component parts indicates the importance of the safety factor of the part. Therefore, when replacing, be sure to use parts of identical designation.
- Parts marked by "☉" are not always kept in stock. Their delivery time may be longer than usual or they may be unavailable.

A – 400X/HL, YPW and A – 400X/HB have the same construction except for the following :

Mark	Symbol & Description	Part No.			Remarks
		A-400X/HB	A-400X/HL	A-400X/YPW	
Δ	AF COMPLEX assembly	AWZ4961	AWZ4962	AWZ4962	
	AC power cord	ADG1136	ADG1113	ADG1137	

AF COMPLEX ASSEMBLY

AWZ4962 and AWZ4961 have the same construction except for the following :

Mark	Symbol & Description	Part No.		Remarks
		AWZ4961	AWZ4962	
	8P speaker terminal	AKE1036	AKE1011	

[REAR PANEL]

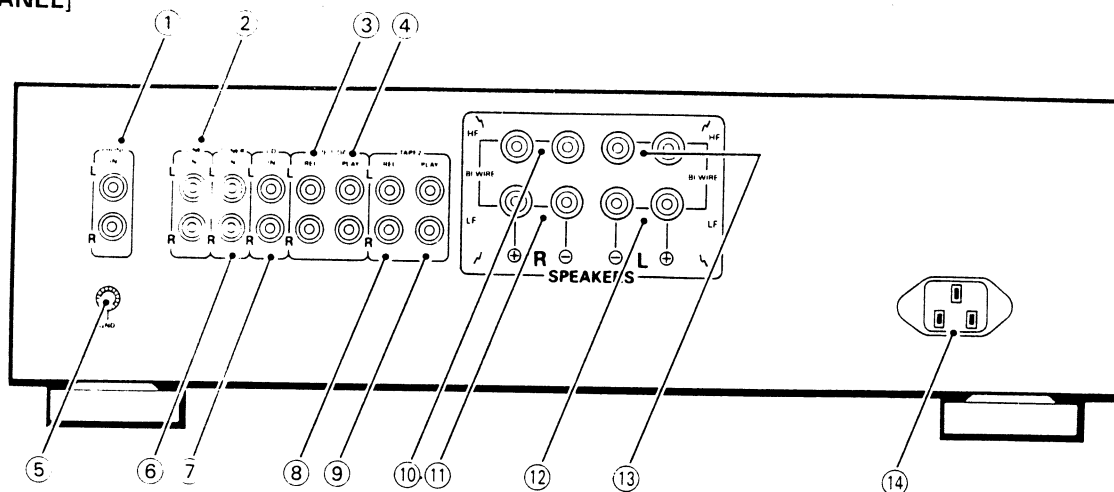

- ① PHONO terminals
- ② LINE terminals
- ③ TAPE 1/DAT REC terminals
- ④ TAPE 1/DAT PLAY terminals
- ⑤ Turntable ground terminal (GRD)
- ⑥ TUNER terminals
- ⑦ CD terminals

- ⑧ TAPE 2 REC terminals
- ⑨ TAPE 2 PLAY terminals
- ⑩ SPEAKERS HF (High Frequency) terminals R (right channel)
- ⑪ SPEAKERS LF (Low Frequency) terminals R (right channel)
- ⑫ SPEAKERS LF (Low Frequency) terminals L (left channel)
- ⑬ SPEAKERS HF (High Frequency) terminals L (left channel)
- ⑭ AC INLET jack

Connect power cord to here and an AC wall socket, or the AC outlet of an audio timer.

9. SPECIFICATIONS

Amplifier Section

Continuous Power Output (both channels driven at 20 Hz to 20 kHz)*	
T.H.D. 0.02 %, 8 Ω	50 W + 50 W
T.H.D. 0.03 %, 4 Ω	70 W + 70 W
DIN Continuous Power Output (both channels driven at 1 kHz)	
T.H.D. 1.0 %, 8 Ω	60 W + 60 W
T.H.D. 1.0 %, 4 Ω	85 W + 85 W
Dynamic Power Output (on EIA dynamic test signal)	
8 Ω/4 Ω/2 Ω	70 W/100 W/150 W
Total Harmonic Distortion*	
20 Hz to 20 kHz, 50 W, 8 Ω	0.02 %
20 Hz to 20 kHz, 70 W, 4 Ω	0.03 %
Input Sensitivity/Impedance	
PHONO (MM)	2.8 mV/50 kΩ
PHONO (MC)	0.24 mV/100 Ω
CD, TUNER, LINE, TAPE	200 mV/40 kΩ
PHONO Overload Level	
1 kHz, T.H.D. 0.1 % (MM/MC)	150 mV/10 mV
Output Level/Impedance	
TAPE REC	200 mV/1 kΩ
Frequency Response	
PHONO (MM)	20 Hz to 20 kHz, ±0.3 dB
PHONO (MC)	20 Hz to 20 kHz, ±0.5 dB
CD, TUNER, LINE, TAPE	1 Hz to 300 kHz, ±½ dB
Signal-to-Noise ratio (IHF short circuit, A network)	
PHONO (MM, 2.8 mV input/MC, 0.24 mV input)	86 dB/67 dB
CD, TUNER, LINE, TAPE	110 dB
Signal-to-Noise ratio (DIN, continuous power/50 mW)	
PHONO (MM)	74 dB/68 dB
CD, TUNER, LINE, TAPE	93 dB/71 dB

Power Supply/Miscellaneous

Power Requirements

U.K. and Australian models	a.c. 240 Volts ~, 50/60 Hz
Singapore model	a.c. 220—230 Volts ~, 50/60 Hz
Power Consumption	520 W
Dimensions	420 (W) x 352 (D) x 126 (H) mm
Weight (without package)	7.5 kg

Accessories

Operating Instructions	1
AC cord	1

- Specifications and design subject to possible modification without notice, due to improvements.

* Measured by Audio Spectrum Analyzer.

8. PANEL FACILITIES

[FRONT PANEL]

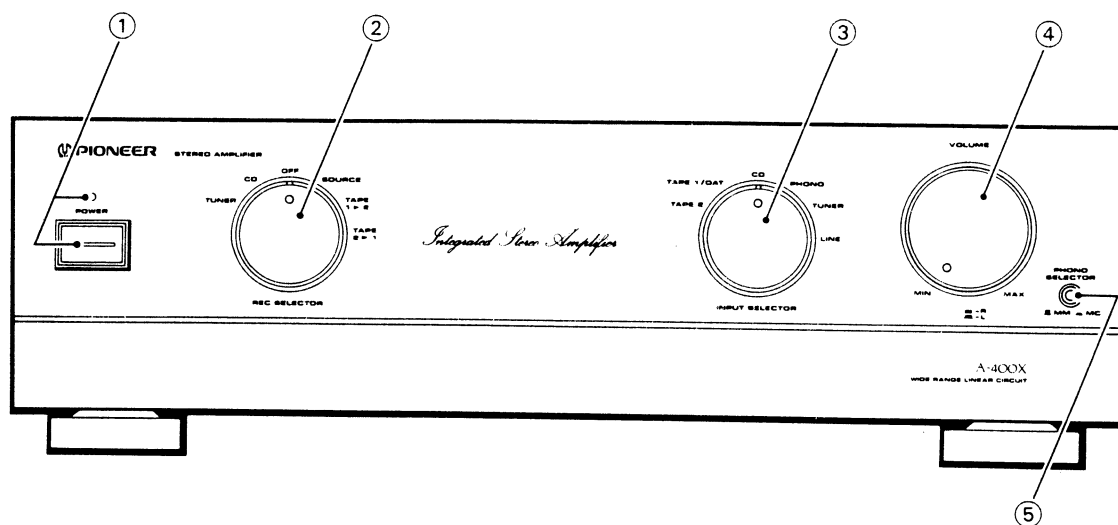

① POWER switch/indicator

Press to turn power to the unit on and off.
When the power is on, the indicator lights.

② REC SELECTOR switch

When this switch is set to a position other than SOURCE or OFF, the equipment selected by REC SELECTOR switch can be recorded from, irrespective of the setting of INPUT SELECTOR switch.

TUNER:

To record from the equipment connected to TUNER terminals.

CD:

To record from the equipment connected to CD terminals.

OFF:

In this position, nothing from the REC terminals of TAPE 1/DAT and TAPE 2 is output. Set to this position when not recording; the cassette deck will be disconnected, improving sound quality.

SOURCE:

To record from the equipment selected by INPUT SELECTOR switch.

TAPE 1 ► 2:

To record (copy) from the cassette deck of TAPE 1/DAT terminals, to the cassette deck of TAPE 2 terminals.

TAPE 2 ► 1:

To record (copy) from the cassette deck of TAPE 2 terminals, to the cassette deck of TAPE 1/DAT terminals.

③ INPUT SELECTOR switch

Use to select the playback source.

LINE:

For playback with a component connected to LINE terminal.

TUNER:

For AM or FM broadcast reception with a tuner.

PHONO:

For record playback with a turntable.

CD:

For compact disc playback with a CD player.

TAPE 1/DAT:

For playback with a cassette deck or digital audio tape deck connected to TAPE 1/DAT terminals.

TAPE 2:

For playback with a cassette deck connected to TAPE 2 terminals.

④ VOLUME control

Use to adjust the volume level.

This volume knob consists of two volume controls. Because you can adjust L (left) and R (right) channel volume levels independently, it also functions as a balance control.

[Example]

To raise R (right) channel volume level, prevent the L knob from turning with one hand, and turn the R knob with the other hand.

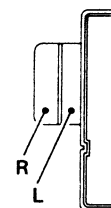

⑤ PHONO SELECTOR switch

Set in accordance with the type of cartridge used with your turntable.

MM (■):

Set to this position when using a moving magnet cartridge, or a moving coil cartridge with a high output of 1 mV or more.

MC (■):

Set to this position when using a moving coil cartridge.