

Operating Instructions

STEREO AMPLIFIER

A-757

A-656

"A-656" is not available in U.S.

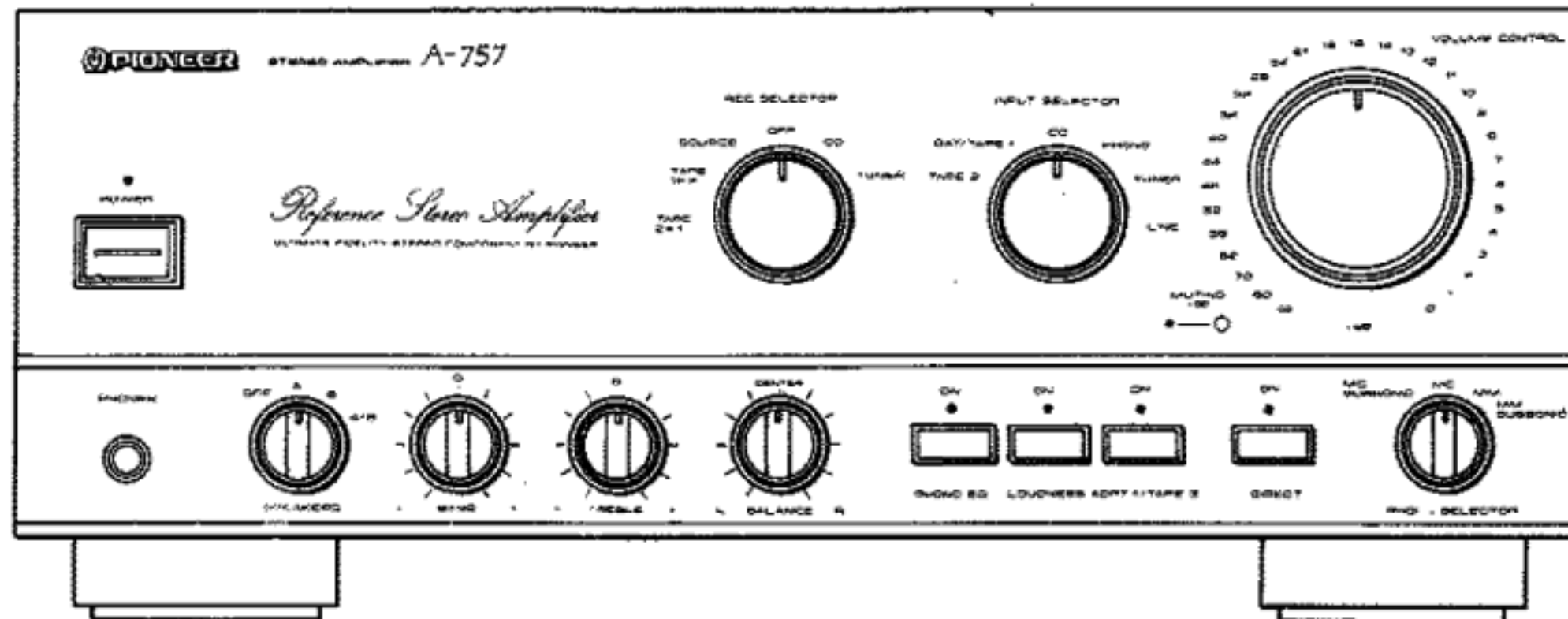

The illustration shows model A-757.

Thank you for buying this Pioneer product.

Please read through these operating instructions so you will know how to operate your unit properly. After you have finished reading the instructions, keep the manual in a safe place for future reference.

In some countries or regions, the shape of the power plug and power outlet may sometimes differ from that shown in the drawings. However, the method of connecting and operating the unit is the same.

WARNING : TO PREVENT FIRE OR SHOCK HAZARD, DO NOT EXPOSE THIS APPLIANCE TO RAIN OR MOISTURE.

IMPORTANT NOTICE [FOR U.S. and Canadian models]

The serial number for this equipment is located on the rear panel. Please write this serial number on your enclosed warranty card and keep it in a secure area. This is for your security.

[For Canadian model]

CAUTION: TO PREVENT ELECTRIC SHOCK DO NOT USE THIS (POLARIZED) PLUG WITH AN EXTENSION CORD, RECEPTACLE OR OTHER OUTLET UNLESS THE BLADES CAN BE FULLY INSERTED TO PREVENT BLADE EXPOSURE.

ATTENTION : POUR PREVENIR LES CHOCS ELECTRIQUES NE PAS UTILISER CETTE FICHE POLARISEE AVEC UN PROLONGATEUR UNE PRISE DE COURANT OU UNE AUTRE SORTIE DE COURANT, SAUF SI LES LAMES PEUVENT ETRE INSEREES A FOND SANS EN LAISSER AUCUNE PARTIE A DECOUVERT.

LINE VOLTAGE SELECTOR SWITCH

Only multi-voltage models are provided with this switch. U.S., Canadian, European, U.K., and Australian models are not provided with this switch.

Mains voltages in Saudi Arabia are 127V and 220V only. Never use this model with 110V setting in Saudi Arabia.

The line voltage selector switch is on the rear panel. Before your model is shipped from the factory, this switch is set to the power requirements of the destination. Check that it is set properly before plugging the power cord into the AC wall socket. If the voltage is not properly set or if you move to an area where the voltage requirements differ, adjust the selector switch as follows.

1. Use a medium-size screwdriver.
2. Insert the screwdriver into the groove on the voltage selector, and adjust so that the tip of the arrow points to the voltage value of your area.

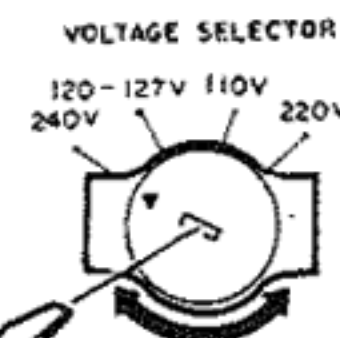

Medium-size screwdriver

PIONEER
The future of sound and vision.

IMPORTANT 1



The lightning flash with arrowhead, within an equilateral triangle, is intended to alert the user of the presence of uninsulated "dangerous voltage" within the product's enclosure that may be of sufficient magnitude to constitute a risk of electric shock to persons.

CAUTION
RISK OF ELECTRIC SHOCK
DO NOT OPEN

CAUTION:
TO PREVENT THE RISK OF ELECTRIC SHOCK, DO NOT REMOVE COVER (OR BACK). NO USER-SERVICEABLE PARTS INSIDE. REFER SERVICING TO QUALIFIED SERVICE PERSONNEL.



The exclamation point within an equilateral triangle is intended to alert the user of the presence of important operating and maintenance (servicing) instructions in the literature accompanying the appliance.

IMPORTANT 2

If the apparatus is fitted with AC mains power outlet(s), see REAR PANEL FACILITIES for convenient connection of additional Hi-Fi component(s). Make all connections to the AC outlet(s) and the signal terminals first. Connect the plug to the wall socket last, make sure that the power switch is off.

FOR USE IN THE UNITED KINGDOM

The wires in this mains lead are coloured in accordance with the following code:

Blue: Neutral
Brown: Live

As the colours of the wires in the mains lead of this apparatus may not correspond with the coloured marking identifying the terminals in your plug proceed as follows:

The wire which is coloured blue must be connected to the terminal which is marked with the letter N or coloured black.

The wire which is coloured brown must be connected to the terminal which is marked with the letter L or coloured red.

Equipment sold in the U.K. is not supplied with a power plug.

SAFETY INSTRUCTIONS

READ INSTRUCTIONS — All the safety and operating instructions should be read before the appliance is operated.

RETAIN INSTRUCTIONS — The operating instructions should be retained for future reference.

HEED WARNING — All warnings on the appliance and in the operating instructions should be adhered to.

FOLLOW INSTRUCTIONS — All operating and use instructions should be followed.

WATER AND MOISTURE — The appliance should not be used near water — for example, near a bathtub, washbowl, kitchen sink, laundry tub, in a wet basement, or near a swimming pool, etc.

LOCATION — The appliance should be installed in a stable location.

WALL OR CEILING MOUNTING — The appliance should not be mounted to a wall or ceiling.

VENTILATION — The appliance should be situated so that its location or position does not interfere with its proper ventilation. For example, the appliance should not be situated on a bed, sofa, rug, or similar surface that may block the ventilation openings; or, placed in a built-in installation, such as a bookcase or cabinet that may impede the flow of air through the ventilation openings.

HEAT — The appliance should be situated away from heat sources such as radiators, heat registers, stoves, or other appliances (including amplifiers) that produce heat.

POWER SOURCES — The appliance should be connected to a power supply only of the type described in the operating instructions or as marked on the appliance.

POWER-CORD PROTECTION — Power-supply cords should be routed so that they are not likely to be walked on or pinched by items placed upon or against them, paying particular attention to cords at plugs, convenience receptacles, and the point where they exit from the appliance.

POLARIZATION — If your purchased product is provided with a polarized power plug, please read the following instructions. This product is equipped with a polarized alternating current line plug (a plug having one blade wider than the other). This plug will fit into the power outlet only one way. This is a safety feature. If you are unable to insert the plug fully into the outlet, try reversing the plug. If the plug should still fail to fit, contact your electrician to replace your obsolete outlet. Do not defeat the safety purpose of the polarized plug.

CLEANING — The appliance should be cleaned only with a polishing cloth or a soft dry cloth. Never clean with furniture wax, benzene, insecticides or other volatile liquids since they may corrode the cabinet.

POWER LINES — An outdoor antenna should be located away from power lines.

NONUSE PERIODS — The power cord of the appliance should be unplugged from the outlet when left unused for a long period of time.

OBJECT AND LIQUID ENTRY — Care should be taken so that objects do not fall and liquids are not spilled into the enclosure through openings.

DAMAGE REQUIRING SERVICE — The appliance should be serviced by a Pioneer authorized service center or qualified service personnel when:

- The power-supply cord or the plug has been damaged; or
- Objects have fallen, or liquid has been spilled into the appliance; or
- The appliance has been exposed to rain; or
- The appliance does not appear to operate normally or exhibits a marked change in performance; or
- The appliance has been dropped; or the enclosure damaged.

SERVICING — The user should not attempt to service the appliance beyond that described in the operating instructions. For all other servicing, contact the nearest Pioneer authorized service center.

OUTDOOR ANTENNA GROUNDING — If an outside antenna is connected to the antenna terminal, be sure the antenna system is grounded so as to provide some protection against voltage surges and built up static charges.

In the U.S.A. section 810 of the National Electrical Code, ANSI/NFPA No. 70-1984, provides information with respect to proper grounding of the mast and supporting structure, grounding of the lead-in wire to an antenna discharge unit, size of grounding conductors, location of antenna discharge unit, connection to grounding electrodes, and requirements for the grounding electrode: See Fig. A.

CART — An appliance and cart combination should be moved with care. Quick stops, excessive force, and uneven surfaces may cause the appliance and cart combination to overturn.

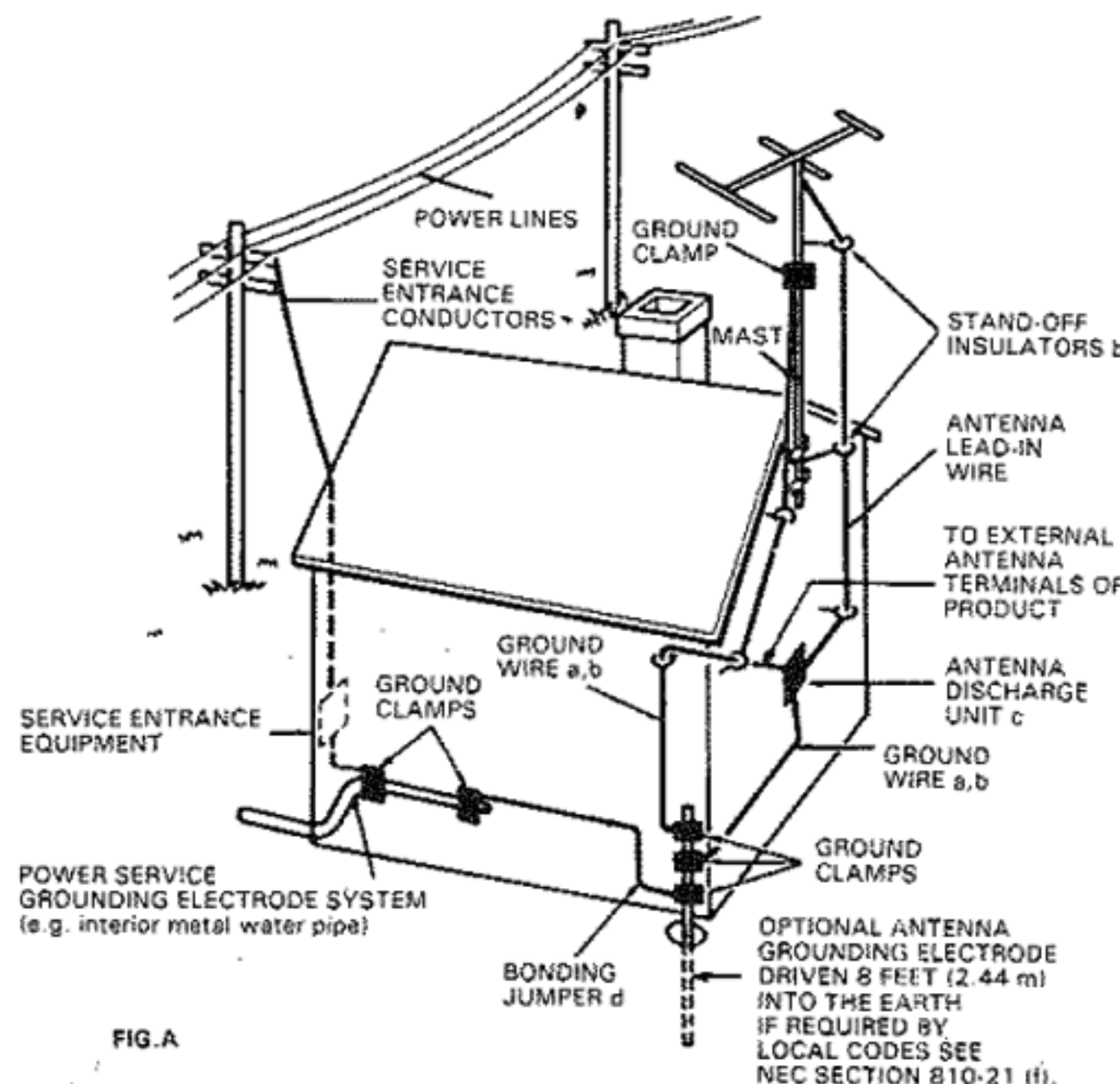

FIG. A

- Use No. 10 AWG (5.3 mm²) copper, No. 8 AWG (8.4 mm²) aluminum, No. 17 AWG (1.0 mm²) copper-clad steel, bronze wire, or larger as ground wire.
- Secure antenna lead-in and ground wires to house with stand-off insulators spaced from 4 feet (1.22 meters) to 6 feet (1.83 meters) apart.
- Mount antenna discharge unit as closely as possible to where lead-in enters house.
- Use jumper wire not smaller than No. 6 AWG (13.3 mm²) copper, or the equivalent, when a separate antenna-grounding electrode is used. See NEC Section 810-21 (j).

CONTENTS

FEATURES	3	OPERATIONS	9
CONNECTIONS	4	TROUBLESHOOTING	10
PANEL FACILITIES	6	SPECIFICATIONS	11

FEATURES

These operating instructions are for:

A-757; 150W + 150W/4 Ω (DIN) power model

A-656; 120W + 120W/4 Ω (DIN) power model

The illustrations and text in this manual refer basically to A-757.

- Drive capacity 150W + 150W/4 Ω (DIN) matching to high power and low-impedance-type speaker system.
[model A-656 120W + 120W/4 Ω (DIN)]
- The use of DIRECT circuit assures high fidelity playback of consistent frequency characteristics, accompanied by maximum clarity.

- REC SELECTOR switch makes tape editing very simple.
- Clean ground technology prevents noise on power line to flow to the signal ground line, permitting clean sound reproduction.
- Non-Switching Circuit Type III (A-656 is Type II) is employed to realize high quality sound with minimum distortion.
- Comes with a built-in phono equalizer which accepts MC cartridge.
- Casted Power Transformer (A-757 only)
- Honeycomb Frame Chassis
- Honeycomb Heat Sink

CONNECTIONS

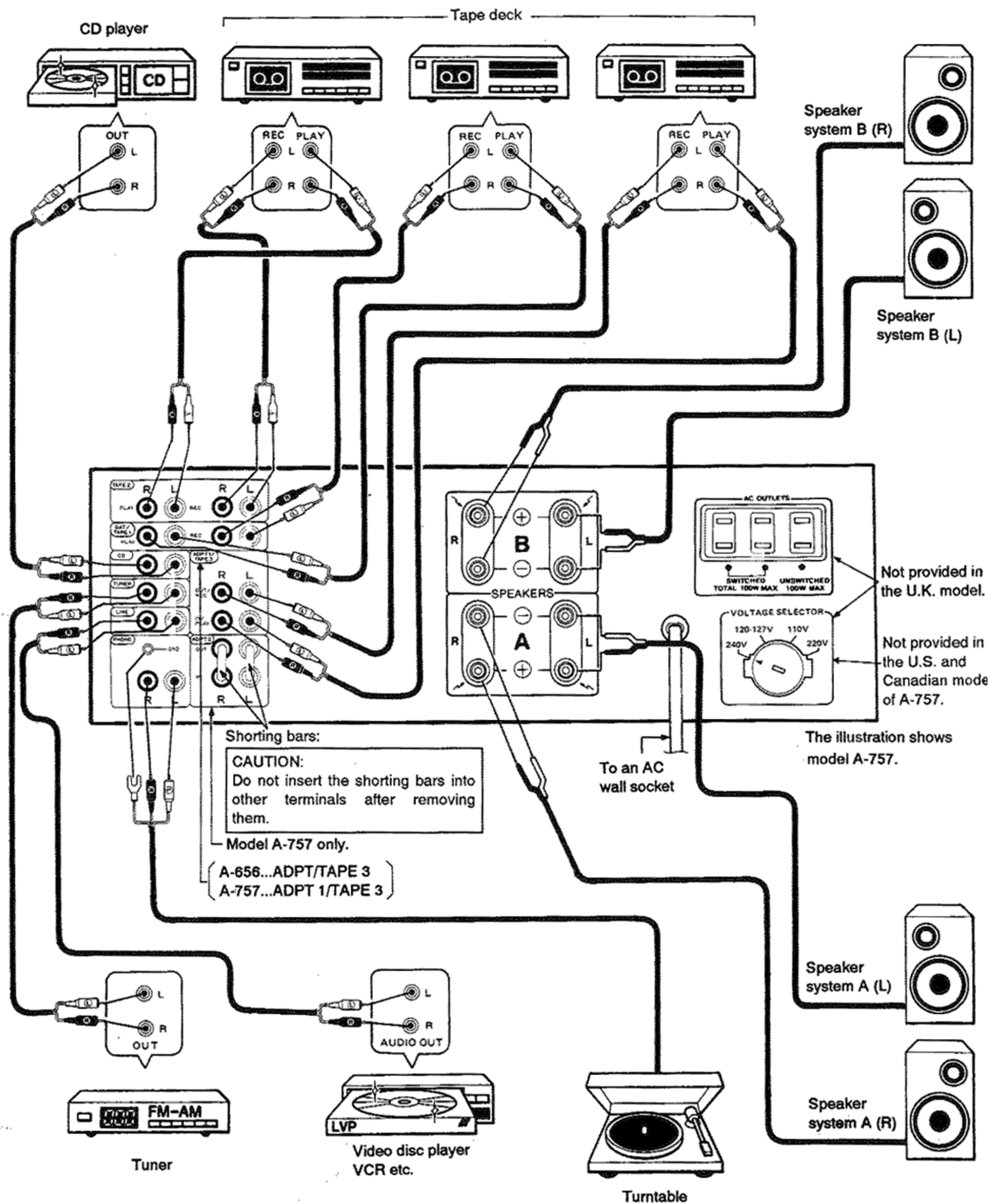

CONNECTING SPEAKER CORDS

1. Strip off the vinyl covering and twist the tip of the wire core.



Twist the wire core.

2. Loosen the knob and insert the wire core into the terminal hole.
3. Tighten the knob to fix the wire core in place.

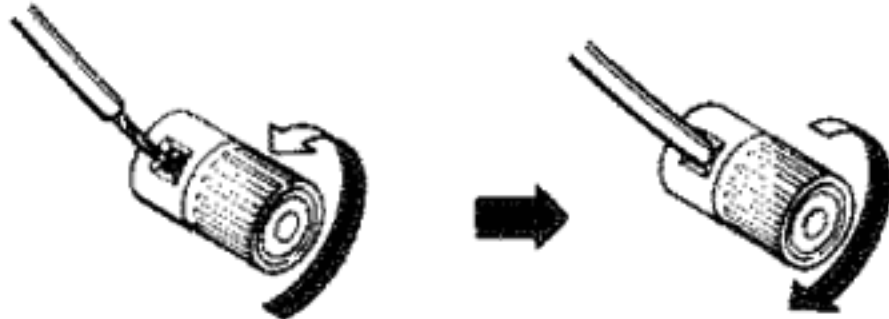

NOTE:

Do not allow the wire core to protrude and touch other terminals or wires. If the cores of different wires touch, damage may be caused to your components.

Speaker Impedance

When speaker systems are connected to only one of the SPEAKERS A or B terminals, such speakers should have rated impedance in the range of 4 – 16 Ω .

When speakers are connected to both the A and B terminals, they should have a rated impedance in the range of 8 – 32 Ω .

CONNECTING INPUT/OUTPUT CORDS

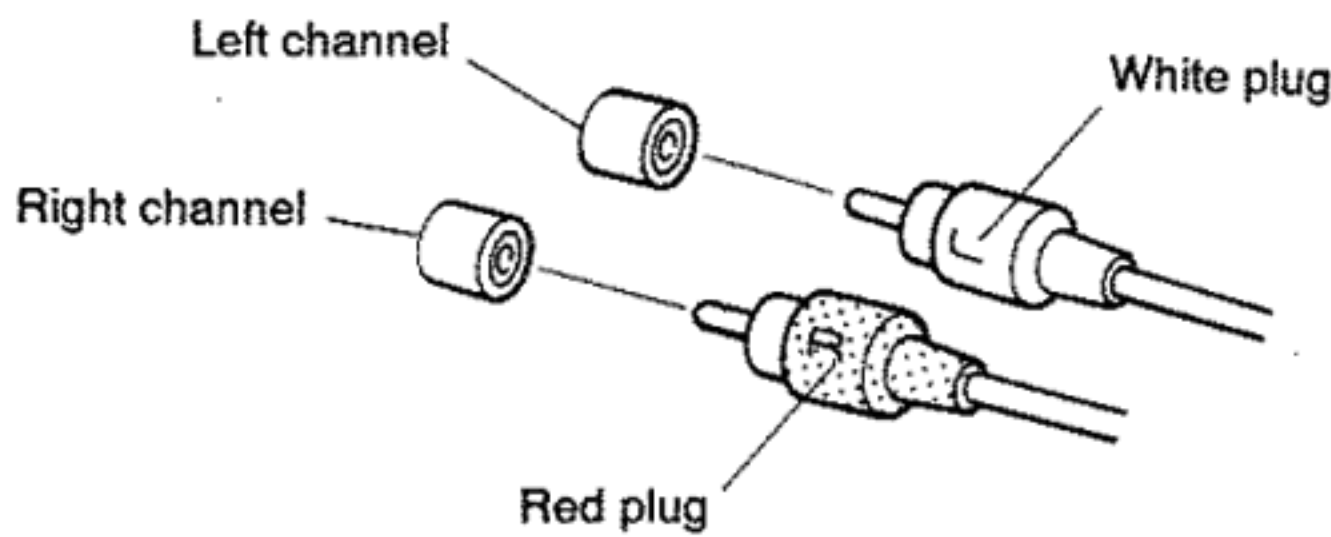

Connect the white plug to the L (left) side, and the red plug to the R (right) side. Be sure to push the plugs in securely.

TO USE THE COMPONENT CONNECTED TO THE ADPT 2 TERMINALS (A-757 only)

1. Set the POWER switch to OFF.
2. Remove the two shorting bars from the ADPT 2 terminals.

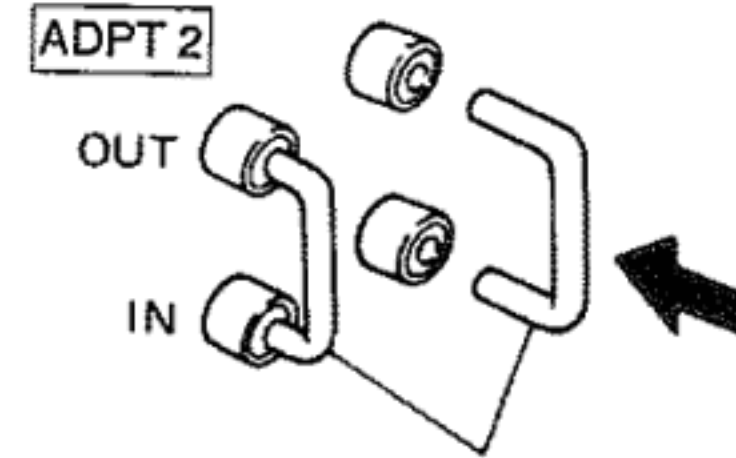

Shorting bars.

NOTE:

Remove the shorting bars to connect a graphic equalizer to these terminals. Always keep the bars inserted while the terminals are not in use, and take care not to lose them.

A-757

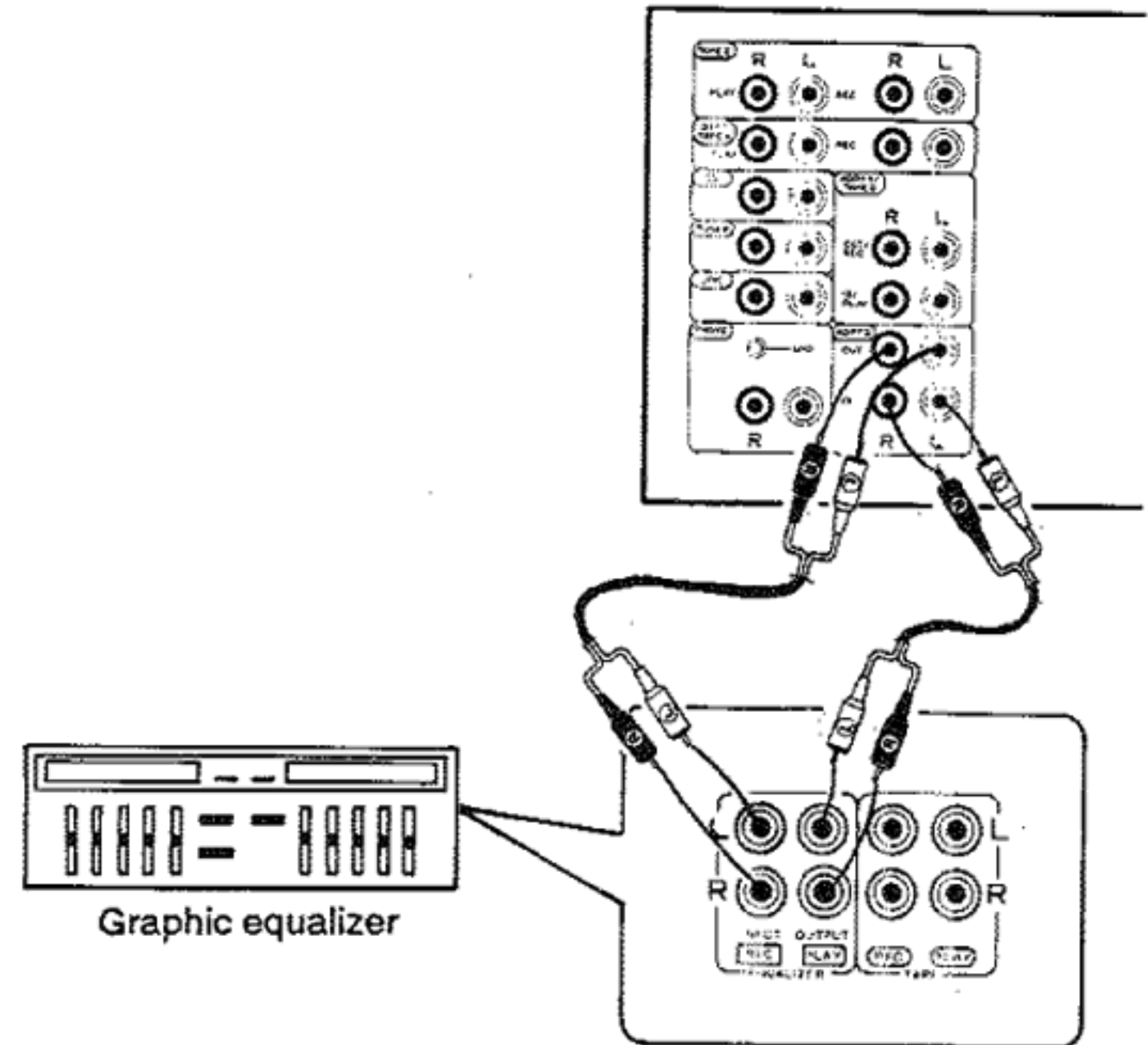

The U.K. model is not provided with the AC OUTLETS.

AC OUTLETS (SWITCHED)

Power supplied through these outlets is turned on and off by the amplifier's POWER switch. Total electrical power consumption of connected equipment should not exceed 100 W (model A-656 of the other destination are 150W).

AC OUTLET (UNSWITCHED)

Power flows continually to this outlet, regardless of whether the amplifier is switched ON or OFF. Electrical power consumption of the connected equipment should not exceed 100 W.

The equipment should be disconnected by removing the power plug from the wall socket when not in regular use, e.g., when on vacation.

NOTE:

Do not connect appliances with high power consumption such as heaters, irons, or television sets to the AC OUTLETS in order to avoid overheating or fire risk.

PANEL FACILITIES

[FRONT PANEL]

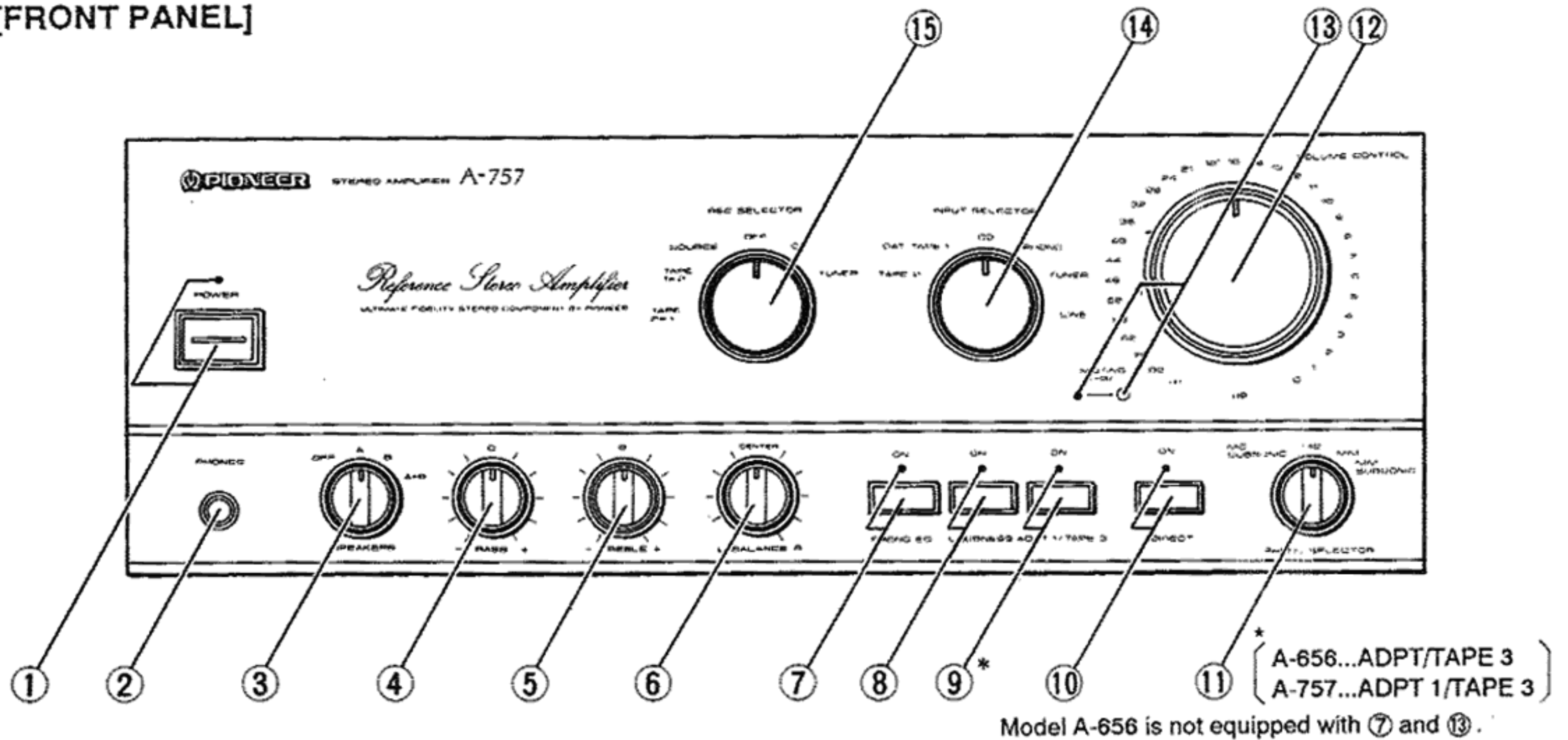

① POWER switch/indicator

Press to turn power to the unit ON and OFF.
When the power is ON, indicator lights.

② PHONES jack

When using headphones, insert the plug into this jack.

③ SPEAKERS selector switch

Use this switch to listen to the speaker systems connected to the SPEAKERS terminals.

OFF:

Released position: No sound is heard from the speaker system.
Set to this position when listening with headphones.

A:

For reproduction of sound with the speaker systems connected to the SPEAKERS A terminals.

B:

For reproduction of sound with the speaker systems connected to the SPEAKERS B terminals.

A + B:

For reproduction of sound with the speaker systems connected to SPEAKERS A and B terminals.

④ BASS tone control

Use to adjust the low-frequency tone at low volume level. The center position is the flat (normal) position. When turned to the right, low-frequency tones are emphasized; when turned to the left, low-frequency tones are de-emphasized.

NOTE:

This function does not operate when the DIRECT switch is in the ON position.

⑤ TREBLE tone control

Use to adjust the high-frequency tone at low volume level. The center position is the flat (normal) position. When turned to the right, high-frequency tones are emphasized; when turned to the left, high-frequency tones are de-emphasized.

6

<ARB1175>

E

NOTE:

This function does not operate when the DIRECT switch is in the ON position.

⑥ BALANCE control

Should normally be left in the center position. Adjust balance if the sound is louder from one of the speakers. If the right side is louder, turn toward the LEFT position and if the left side is louder, turn toward the RIGHT position.

NOTE:

This function does not operate when the DIRECT switch is in the ON position.

⑦ PHONO EQ switch/indicator (A-757 only)

When not using a phono input, turn the phono equalizer power circuit off in order to prevent it from collecting noise during playback of other sources.

ON:

The indicator lights: Always set to this position when using a phono input. Immediately after turning ON, audio signal will be muted for several seconds until circuit operation becomes stable.

OFF:

The indicator goes off: Set to this position when not using a phono input.

⑧ LOUDNESS switch/indicator

Use when listening at low volume levels.

ON:

The indicator lights: Boosts low and high frequencies to give added punch to playback even at low-volume.

OFF:

The indicator goes off: Should normally be left in this position.

NOTE:

This switch does not operate when the DIRECT switch is in the ON position.

⑨ **ADPT 1/TAPE 3 switch/indicator (ADPT/TAPE 3 switch in the A-656)**

Use this switch to listen to tape playback, or to listen to the sounds being recorded during tape recording.

ON:

The indicator lights: Press when listening to the playback sound of the tape deck or the adaptor connected to the ADPT 1/TAPE 3 IN/PLAY terminals, or to monitor the sound being recorded on the tape deck connected to the ADPT 1/TAPE 3 OUT/REC terminals.

OFF:

The indicator goes off: Normally leave the switch in this position.

NOTE:

When the DIRECT switch is set to ON, this function does not operate and no signal is output at the ADPT 1/TAPE 3 OUT/REC terminals.

⑩ **DIRECT switch/indicator**

Use this switch when you do not wish to pass the output from input terminal equipment through the various frequency adjusting circuits and adaptor terminals (ADPT 1/TAPE 3, ADPT 2, BASS, TREBLE, BALANCE, LOUDNESS).

ON:

When the switch is in this position, the indicator lights and the signals input from the input terminals are reproduced without passing through the various frequency-adjusting circuits. This results in flat, pure sound which is a more faithful reproduction of the input source.

OFF:

When the switch is in this position the indicator goes out and the signal passes through the various frequency adjusting circuits.

⑪ **PHONO SELECTOR switch**

Set in accordance with the type of cartridge used in you turntable.

MM:

Set to this position when using a moving magnet cartridge, or a MC (moving coil) cartridge with high output of 1 mV or more.

MC:

Set to this position when using a moving coil cartridge.

MM SUBSONIC/MC SUBSONIC:

Subsonic filter for moving coil or moving magnet cartridges to cut ultralow frequency noise less than 17 Hz generated when playing a warped record.

When using a high-output moving coil cartridge, set this switch to MM or MM SUBSONIC.

⑫ **VOLUME CONTROL**

Use to adjust volume level.

NOTE:

This unit is equipped with a circuit that attenuates the effect of tone and loudness controls at volume is turned up.

⑬ **MUTING switch/indicator (A-757 only)**

Use to temporarily cut sound volume.

ON:

The indicator lights. The sound volume will be cut off.

OFF:

The indicator goes off. The sound will return to its previous volume.

⑭ **INPUT SELECTOR switch**

Use to select playback source.

LINE:

Set to this position when listening to the programs from a component connected to the LINE terminals.

TUNER:

Set to this position when listening to AM or FM broadcasts with a tuner.

PHONO:

Set to this position when listening to record playback on a turntable.

CD:

Set to this position when listening to a compact disc playback with a CD player.

DAT/TAPE 1:

For playback with a tape deck or digital audio tape deck connected to the DAT/TAPE 1 terminals.

TAPE 2:

For playback with a tape deck connected to the TAPE 2 terminals.

⑮ **REC SELECTOR switch**

Switch to select recording signal. When set at other than SOURCE or OFF position, signals can be recorded during playback of the equipment selected by INPUT SELECTOR switch.

TUNER:

To record from a TUNER.

CD:

To record from a CD player.

OFF:

In this position nothing from the REC terminals of DAT/TAPE 1 and TAPE 2 will be output. Select it when not recording; output to tape decks will be disconnected, improving sound quality.

SOURCE:

To record the equipment selected by INPUT SELECTOR switch.

TAPE:

1 ► 2

To record (copy) from the tape deck of DAT/TAPE 1 terminals, over to the tape deck of TAPE 2 terminals.

2 ► 1

To record (copy) from the tape deck of TAPE 2 terminals, over to the tape deck of DAT/TAPE 1 terminals.

NOTE:

The REC SELECTOR switch has no effect on the recording out put of the ADPT 1/TAPE 3 terminals.

PANEL FACILITIES

[REAR PANEL]

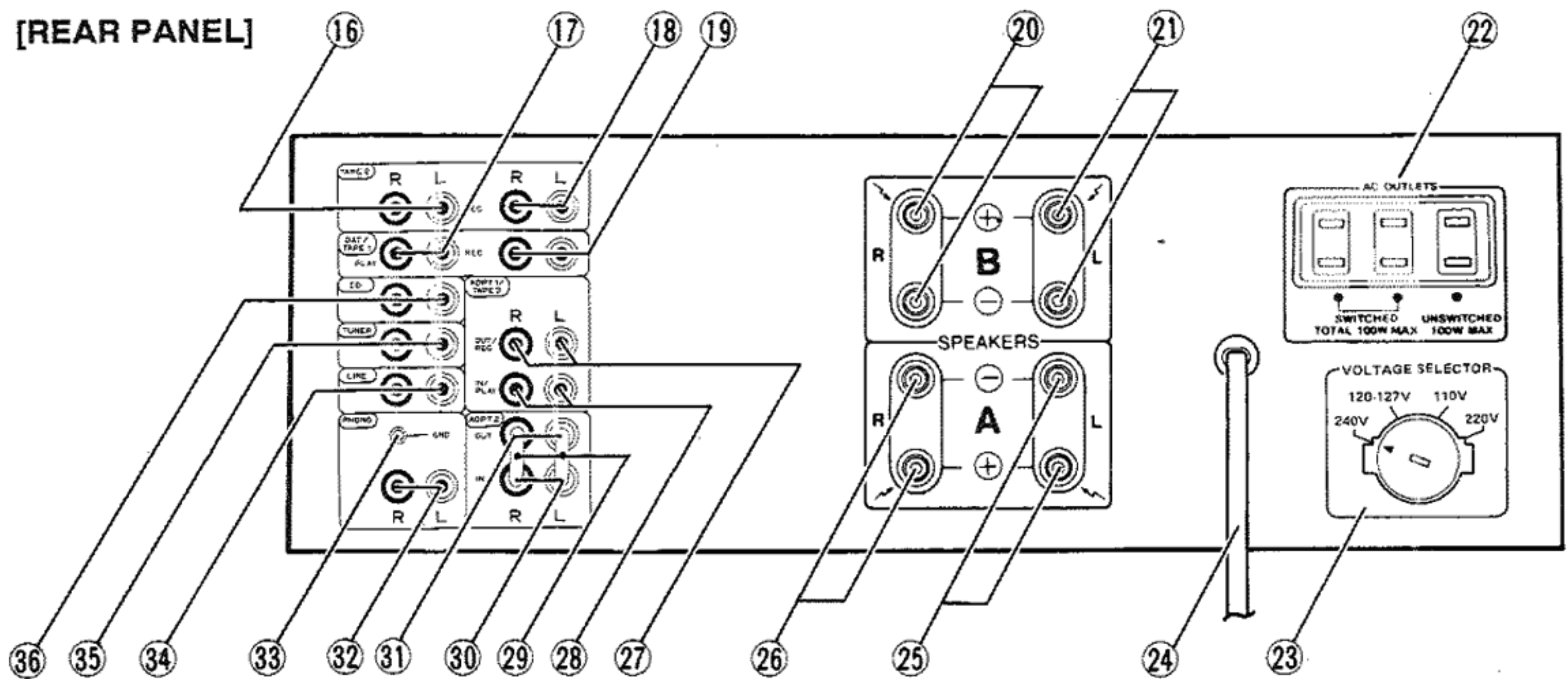

The illustration shows model A-757.

- ⑩ **TAPE 2 PLAY terminals.**
- ⑪ **DAT/TAPE 1 PLAY terminals.**
- ⑫ **TAPE 2 REC terminals.**
- ⑬ **DAT/TAPE 1 REC terminals.**
- ⑭ **SPEAKERS B terminals (right channel).**
- ⑮ **SPEAKERS B terminals (left channel).**
- ⑯ **AC OUTLETS. (Not provided in the U.K. model)**
- ⑰ **VOLTAGE SELECTOR.**
(Not provided in the U.K. model and, U.S. & Canadian models of A-757)
- ⑱ **Power cord.**
Connect this cord to an AC wall socket, or the AC outlet of an audio timer.
- ⑲ **SPEAKERS A terminals (left channel).**
- ⑳ **SPEAKERS A terminals (right channel).**
- ㉑ **ADPT 1/TAPE 3 OUT/REC terminals.**
- ㉒ **ADPT/TAPE 3 OUT/REC terminals. (A-656 only)**
- ㉓ **ADPT 1/TAPE 3 IN/PLAY terminals.**
- ㉔ **ADPT/TAPE 3 IN/PLAY terminals. (A-656 only)**
- ㉕ **Shorting bars. (A-757 only)**
- ㉖ **ADPT 2 IN terminals. (A-757 only)**
- ㉗ **ADPT 2 OUT terminals. (A-757 only)**
- ㉘ **PHONO terminals.**
- ㉙ **Turntable ground terminal (GND).**
- ㉚ **LINE terminals.**
- ㉛ **TUNER terminals.**
- ㉜ **CD terminals.**

OPERATIONS

BEFORE BEGINNING OPERATIONS

Set the controls and switches as follows: See page 6.

1. Set the **VOLUME CONTROL** to minimum. ⑫
2. Set the **POWER** switch to **ON**. ①
3. Set the **SPEAKERS** switch to **A, B** or **A + B**. ③
4. Set the **BALANCE** control to the center position. ⑥
5. Set the **DIRECT** switch to **OFF**. ⑩
6. Set the **ADPT 1/TAPE 3** switch to **OFF**. ⑨

PLAYBACK PROCEDURES

1. Set the **INPUT SELECTOR** or **ADPT 1/TAPE 3** switch. ⑭, ⑨

How to select playback source;

- When listening to programs from equipment connected to the **LINE** terminals: Set to [LINE].
- When listening to an **AM/FM** broadcast: Set to [TUNER].
- When listening to a record: Set to [PHONO].
PHONO EQ switch to **ON**. (A-757 only)
Set **PHONO SELECTOR** switch to **MM** (MM SUBSONIC) or **MC** (MC SUBSONIC) according to the type of cartridge being used.
- When listening to a compact disc: Set to [CD].
- When listening to a tape: Set to [DAT/TAPE 1], [TAPE 2] or [ADPT 1/TAPE 3].

2. Operate the playback equipment.
3. Adjust playback volume with the **VOLUME CONTROL** on this unit. ⑫

RECORDING TAPES

1. Select the recording source with **REC SELECTOR** switch.

- When set to the **SOURCE** position, the signals from the device selected by **INPUT SELECTOR** switch are recorded. (To record signals from the device connected to the **PHONO** or **LINE** terminals, set the **REC SELECTOR** switch to **SOURCE** and set the **INPUT SELECTOR** switch to **PHONO** or **LINE**.)
When recording the signal from **PHONO** terminal, set **PHONO EQ** switch to **ON** position. (A-757 only)
- Recording is impossible with the switch set to **OFF**.

NOTE:

When this switch is set at other than **SOURCE** position, the equipment selected by **REC SELECTOR** switch can be recorded, regardless of the setting of **INPUT SELECTOR** and **DIRECT** switches.

2. When using the tape deck connected to the **ADPT 1/TAPE 3** terminals for recording. ⑨

The source selected with the **INPUT SELECTOR** will be recorded, regardless of the **REC SELECTOR** position.
However, recording will not be possible when the **DIRECT** switch is **ON**.

3. Begin recording by operating the source equipment and tape deck.

Refer to the operating instructions for your tape deck for proper operating procedures.

MONITORING WHILE RECORDING

When recording of the tuner or CD only.

On a 3-head tape deck, sound can be concurrently heard while recording. This operation of checking the sound quality and recording level is called "monitoring." At the time of monitoring, set the **INPUT SELECTOR** switch of this equipment in the following way, to match the tape deck on which recording is being done.

- When recording on the tape deck of **DAT/TAPE 1** terminals:
Set to **DAT/TAPE 1**.
- When recording on the tape deck of **TAPE 2** terminals:
Set to **TAPE 2**.
- When recording on the tape deck of **ADPT 1/TAPE 3** terminals:
ADPT 1/TAPE 3 switch to **ON**.

COPYING TAPES:

When two decks (or a double cassette deck) are used, you can record the sounds from one deck onto the other.

Application examples:

- To make a tape copy with contents identical to the original tape.
- To edit a recording of a radio broadcast in order to cut out unwanted commercials, recording only desired material onto another tape.

When using two tape decks

1. Load tapes for playback (pre-recorded tape) and recording into the respective tape decks.
2. Select the tape deck to be copied with **REC SELECTOR** switch.

- When copying from the tape deck of **DAT/TAPE 1** terminals, to the tape deck of **TAPE 2** terminals: Set to 1 ▶ 2.
- When copying from the tape deck of **TAPE 2** terminals, to the tape deck of **DAT/TAPE 1** terminals: Set to 2 ▶ 1.

NOTE:

The tape selected with **REC SELECTOR** switch can be copied, regardless of the settings of **INPUT SELECTOR** and **DIRECT** switches.

3. Operate the tape decks to begin copying.

Set the tape deck with the original (playback) tape to the playback mode, and set the tape deck with the blank tape to the recording mode.

Playback using graphic equalizer

As to A-757, it can deal with playback of all sources when connecting a graphic equalizer to the **ADPT 2** terminals. However, playback is not possible when the **DIRECT** switch is **ON**.

NOTE:

Remove the shorting bars before using these terminals. Always keep the bars inserted while the terminals are not in use, and take care not to lose them (A-757 only).

TROUBLESHOOTING

Incorrect operations are often mistaken for trouble and malfunctions. If you think that there is something wrong with this component, check the points below. Sometimes the trouble may lie in another component. Investigate the other components and electrical appliances being used. If the trouble cannot be rectified even after exercising the checks listed below, ask your nearest PIONEER authorized service center or your dealer to carry out repair work.

Symptom	Probable Cause	Remedy
No power supplied to unit	<ul style="list-style-type: none"> • Power plug is disconnected from outlet. • The component power plug has been plugged into another component power outlet (e.g. timer, etc.), but power to that unit is disconnected. 	<ul style="list-style-type: none"> • Insert plug securely in outlet. • Turn on power to the other component.
No sound	<ul style="list-style-type: none"> • Connecting cords are disconnected from terminals, or connected incorrectly. • Terminals, or connecting cords pin plugs are dirty. • The INPUT SELECTOR or ADPT 1/TAPE 3 switch selected does not match the component being played back. • Operation of other components is incorrect. • The SPEAKERS selector switch is set to "OFF". • The PHONO EQ switch is OFF position (When listening PHONO in A-757.) • Shorting bars are not inserted into the ADPT 2 terminals. 	<ul style="list-style-type: none"> • Connect securely. • Clean terminals and plugs. • Set switches correctly (PHONO, TUNER, CD, LINE, DAT/TAPE 1, TAPE 2). Set the ADPT 1/TAPE 3 to OFF. • Consult the operating instructions for the other components. • Set the switch to A, B or A + B. • Set PHONO EQ switch to ON position. • Insert the shorting bars properly.
No sound from one speaker	<ul style="list-style-type: none"> • Connecting cords or speaker cords are disconnected on that side. • BALANCE control has been adjusted to one side. 	<ul style="list-style-type: none"> • Connect securely. • Adjust BALANCE control to center position.
Can't record tapes	<ul style="list-style-type: none"> • The position of the REC SELECTOR switch is incorrect. • Connections are incorrect. • Operation of tape deck is incorrect. 	<ul style="list-style-type: none"> • Set switch correctly. (See section RECORDING TAPES). • Reconnect cords properly. • Consult the operating instructions for the tape deck.
Can't perform tape copying	<ul style="list-style-type: none"> • The position of the REC SELECTOR switch is incorrect. • Operation of tape decks is incorrect. 	<ul style="list-style-type: none"> • Set switch correctly (See section COPYING TAPES). • Consult the operating instructions for the tape decks.

POWER-CORD CAUTION

Handle the power cord by the plug. Do not pull out the plug by tugging the cord and never touch the power cord when your hands are wet as this could cause a short circuit or electric shock. Do not place the unit, a piece of furniture, etc., on the power cord, or pinch the cord. Never make a knot in the cord or tie it with other cords. The power cords should be routed such that they are not likely to be stepped on. A damaged power cord can cause fire or give you an electrical shock. Check the power cord once in a while. When you find it damaged, ask your nearest PIONEER authorized service center or your dealer for a replacement.

SPECIFICATIONS

[A-757]

Continuous power output (both channels driven at 20 Hz to 20 kHz) **

U.S., Canadian models

Continuous Average Power Output is 100 Watts* per channel, min., at 8 ohms from 20 Hertz to 20,000 Hertz, with no more than 0.003% total harmonic distortion.**

***** Measured pursuant to the federal Trade Commission's Trade Regulation rules on Power Output Claims for Amplifiers.**

FTC continuous power output (both channels driven)

20 Hz to 20 kHz, T.H.D. 0.003%, 8 Ω	100W + 100W *
20 Hz to 20 kHz, T.H.D. 0.005%, 4 Ω	135W + 135W *

U.K. model

T.H.D. 0.003%, 8 Ω	95W + 95W *
T.H.D. 0.005%, 4 Ω	140W + 140W *

Other destination models

T.H.D. 0.003%, 8 Ω	100W + 100W *
T.H.D. 0.005%, 4 Ω	140W + 140W *

DIN continuous power output (both channels driven)

U.K. model

1 kHz, T.H.D. 1.0%, 8 Ω	100W + 100W
1 kHz, T.H.D. 1.0%, 4 Ω	150W + 150W

Total harmonic distortion **

U.S., Canadian models

20 Hz to 20 kHz, 100W, 8 Ω	0.003% *
20 Hz to 20 kHz, 135W, 4 Ω	0.005% *

U.K. model

20 Hz to 20 kHz, 95W, 8 Ω	0.003% *
20 Hz to 20 kHz, 140W, 4 Ω	0.005% *

Other destination models

20 Hz to 20 kHz, 100W, 8 Ω	0.003% *
20 Hz to 20 kHz, 140W, 4 Ω	0.005% *

The followings are applicable to all models.

Power bandwidth

0.05%, 8 Ω	5 Hz - 70 kHz *
------------	-----------------

Damping factor

(1 kHz/20 Hz to 20 kHz), 8 Ω	200/70
------------------------------	--------

Dynamic power output (on EIA dynamic test signal)

4 Ω / 2 Ω	200W/300W
-----------	-----------

Inter-modulation distortion (at rated output)

	0.003% *
--	----------

Input sensitivity/impedance

PHONO (MM)	2.5 mV/50 k Ω
PHONO (MC)	0.2 mV/100 Ω
CD, TUNER, LINE, TAPE	150 mV/50 k Ω

PHONO overload level

1 kHz, T.H.D. 0.008% (MM/MC)	200 mV/19 mV
------------------------------	--------------

Output level/impedance

TAPE REC, ADAPTOR OUTPUT	150 mV/2.2 k Ω
--------------------------	----------------

Frequency response

PHONO (MM), 20 Hz to 20 kHz	± 0.2 dB
PHONO (MC), 20 Hz to 20 kHz	± 0.3 dB
CD, TUNER, LINE, TAPE (1 Hz to 150 kHz)	+0 -3 dB *

Tone control (volume control set at -40 dB position)

BASS	± 8 dB (100 Hz)
TREBLE	± 8 dB (10 kHz)

MUTING -∞

Loudness contour (volume control set at -40 dB position)

	+5 dB (100 Hz)/+3 dB (10 kHz)
--	-------------------------------

Filter (SUBSONIC) 17 Hz (12 dB/oct.)

Signal-to-Noise ratio (IHF short circuit, A network)

PHONO (MM, 5 mV input/MC, 0.5 mV input)	95 dB/77 dB *
CD, TUNER, LINE, TAPE	110 dB *

Signal-to-Noise ratio (DIN, continuous power/50 mW)

PHONO (MM)	74 dB/65 dB *
CD, TUNER, LINE, TAPE	92 dB/68 dB *

Power Supply/Miscellaneous

Power requirements

U.S., Canadian models	AC 120V, 60 Hz
U.K., Australian models	a.c. 240 Volts ~, 50/60 Hz
Other destination models	~AC110V/120 - 127V, /220V/240V (switchable), 50/60 Hz

Power consumption

U.S., Canadian models	500W (650 VA)
U.K., Australian models	820W
Other destination models	820W

AC outlets

switched (× 2)	100W
unswitched (× 1)	100W

Dimensions 420 (W) × 435 (D) × 162 (H) mm
16-9/16 (W) × 17-1/8 (D) × 6-3/8 (H) in

Weight (without package) 19.5 kg (43 lb)

Accessories

Operating instructions	1
Cushion spacer set	1

NOTE:

Specifications and design subject to possible modification without notice, due to improvements.

* When the DIRECT switch to ON.

** Measured by Audio Spectrum Analyzer.

Be sure to place the unit on a level surface so that it stands firmly on all its feet. If wobbly, adjust by attaching the supplied cushion spacers to one or more feet.

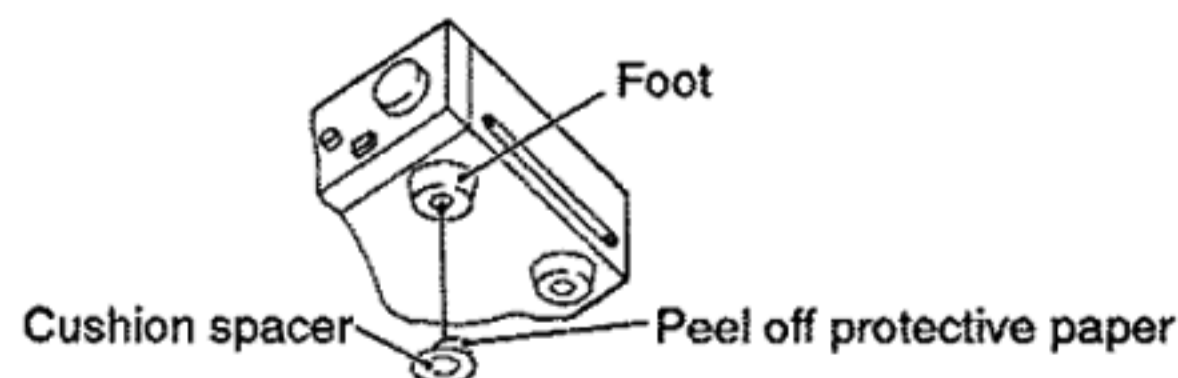

SPECIFICATIONS

[A-656]

Continuous power output (both channels driven at 20 Hz to 20 kHz) **

U.K. model

T.H.D. 0.005%, 8 Ω 70W + 70W *

T.H.D. 0.008%, 4 Ω 95W + 95W *

Other destination models

T.H.D. 0.005%, 8 Ω 80W + 80W *

T.H.D. 0.008%, 4 Ω 100W + 100W *

DIN continuous power output (both channels driven)

U.K. model

1 kHz, T.H.D. 1.0%, 8 Ω 80W + 80W

1 kHz, T.H.D. 1.0%, 4 Ω 120W + 120W

Power bandwidth

0.05%, 8 Ω 5 Hz - 80 kHz *

Damping factor

(1 kHz/20 Hz to 20 kHz), 8 Ω 200/70

Dynamic power output (on EIA dynamic test signal)

4 Ω / 2 Ω 150W/190W

Total harmonic distortion **

U.K. model

20 Hz to 20 kHz, 70W, 8 Ω 0.005% *

20 Hz to 20 kHz, 95W, 4 Ω 0.008% *

Other destination models

20 Hz to 20 kHz, 80W, 8 Ω 0.005% *

20 Hz to 20 kHz, 100W, 4 Ω 0.008% *

Inter-modulation distortion (at rated output) 0.005% *

Input sensitivity/impedance

PHONO (MM) 2.5 mV/50 k Ω

PHONO (MC) 0.2 mV/100 Ω

CD, TUNER, LINE, TAPE 150 mV/50 k Ω

PHONO overload level

1 kHz, T.H.D. 0.008% (MM/MC) 200 mV/19 mV

Output level/impedance

TAPE REC 150 mV/2.2 k Ω

Frequency response

PHONO (MM), 20 Hz to 20 kHz ± 0.2 dB

PHONO (MC), 20 Hz to 20 kHz ± 0.3 dB

CD, TUNER, LINE, TAPE (1 Hz to 150 kHz) +0
-3 dB *

Tone control (volume control set at -40 dB position)

BASS ± 8 dB (100 Hz)

TREBLE ± 8 dB (10 kHz)

Loudness contour (volume control set at -40 dB position)

..... +5 dB (100 Hz)/+3 dB (10 kHz)

Filter (SUBSONIC) 17 Hz (12 dB/oct.)

Signal-to-Noise ratio (IHF short circuit, A network)

PHONO (MM, 5 mV input/MC, 0.5 mV input)

..... 95 dB/77 dB *

CD, TUNER, LINE, TAPE 110 dB *

Signal-to-Noise ratio (DIN, continuous power/50 mW)

PHONO (MM) 74 dB/65 dB *

CD, TUNER, LINE, TAPE 92 dB/68 dB *

Power Supply/Miscellaneous

Power requirements

U.K., Australian models a.c. 240Volts ~, 50/60 Hz

Other destination models
~AC110V/120 - 127V, /220V/240V (switchable), 50/60 Hz

Power consumption

U.K., Australian models 650W

Other destination models 650W

AC outlets

switched (× 2) 150W

unswitched (× 1) 100W

Dimensions 420 (W) × 435 (D) × 162 (H) mm

16-9/16 (W) × 17-1/8 (D) × 6-3/8 (H) in

Weight (without package) 13.5 kg (29 lb 12 oz)

Accessories

Operating instructions 1

NOTE:

Specifications and design subject to possible modification without notice, due to improvements.

* When the DIRECT switch to ON.

** Measured by Audio Spectrum Analyzer.

MAINTENANCE OF EXTERNAL SURFACES

- Use a polishing cloth or dry cloth to wipe off dust and dirt.
- When the surfaces are very dirty, wipe with a soft cloth dipped in some neutral cleanser diluted five or six times with water, and wrung out well, and then wipe again with a dry cloth. Do not use furniture wax or cleaners.
- Never use thinners, benzine, insecticide sprays and other chemicals on or near this unit, since these will corrode the surfaces.

PIONEER ELECTRONIC CORPORATION 4-1, Meguro 1-Chome, Meguro-ku, Tokyo 153, Japan

PIONEER ELECTRONICS [USA] INC. 2265 East 220th Street, Long Beach, California 90810, U.S.A.

P.O. BOX 1720, Long Beach, California 90801, U.S.A.

PIONEER ELECTRONICS OF CANADA, INC. 505 Cochrane Drive, Markham, Ontario L3R 8E3, Canada

PIONEER ELECTRONIC [EUROPE] N.V. Keetberglaan 1, 2740 Beveren, Belgium, TEL: 03/750.0511

PIONEER ELECTRONICS AUSTRALIA PTY. LTD. 178-184 Boundary Road, Braeside, Victoria 3195, Australia, TEL: [03] 580-9911