

3.2 INPUT AND REC OUT ASSEMBLIES

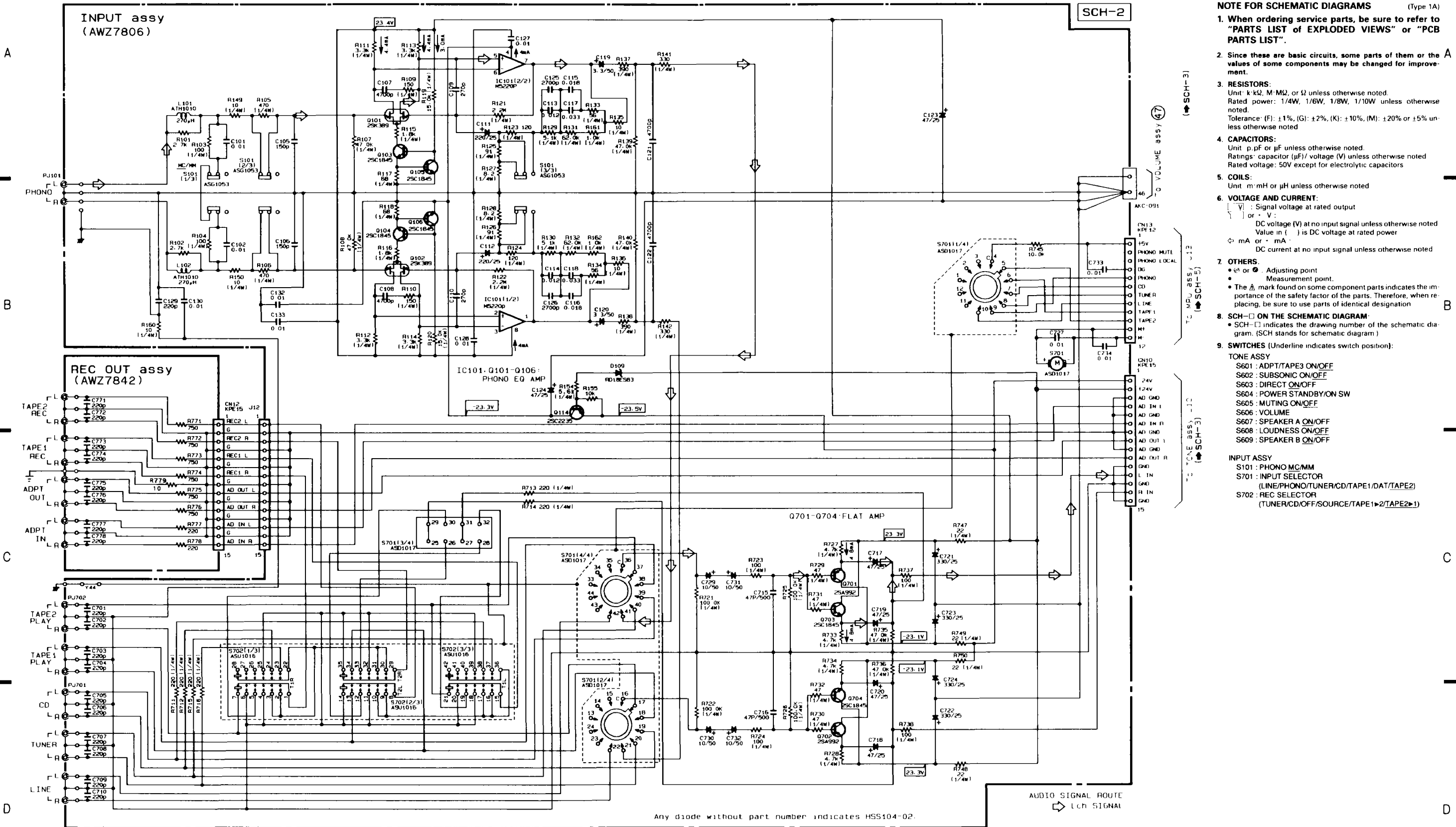

- NOTE FOR SCHEMATIC DIAGRAMS** (Type 1A)
- When ordering service parts, be sure to refer to "PARTS LIST OF EXPLODED VIEWS" or "PCB PARTS LIST".
  - Since these are basic circuits, some parts of them or the values of some components may be changed for improvement.
  - RESISTORS:**  
Unit: k, Ω, M, MΩ, or Ω unless otherwise noted.  
Rated power: 1/4W, 1/8W, 1/2W, 1/10W unless otherwise noted.  
Tolerance: (F): ±1%, (G): ±2%, (K): ±10%, (M): ±20% or ±5% unless otherwise noted.
  - CAPACITORS:**  
Unit: p, pF or μF unless otherwise noted.  
Ratings: capacitor (μF)/voltage (V) unless otherwise noted.  
Rated voltage: 50V except for electrolytic capacitors.
  - COILS:**  
Unit: mH or μH unless otherwise noted.
  - VOLTAGE AND CURRENT:**  
[ V ] : Signal voltage at rated output  
[ V ] : DC voltage (V) at no input signal unless otherwise noted  
[ V ] : DC voltage at rated power  
[ mA ] : DC current at no input signal unless otherwise noted
  - OTHERS:**  
• [ ] or [ ] : Adjusting point  
• [ ] : Measurement point  
• The Δ mark found on some component parts indicates the importance of the safety factor of the parts. Therefore, when replacing, be sure to use parts of identical designation.
  - SCH-□ ON THE SCHEMATIC DIAGRAM:**  
• SCH-□ indicates the drawing number of the schematic diagram. (SCH stands for schematic diagram)
  - SWITCHES** (Underline indicates switch position):  
**TONE ASSY**  
S601 : ADPT/TAPE3 ON/OFF  
S602 : SUBSONIC ON/OFF  
S603 : DIRECT ON/OFF  
S604 : POWER STANDBY/ON SW  
S605 : MUTING ON/OFF  
S606 : VOLUME  
S607 : SPEAKER A ON/OFF  
S608 : LOUDNESS ON/OFF  
S609 : SPEAKER B ON/OFF
  - INPUT ASSY**  
S101 : PHONO MC/MM  
S701 : INPUT SELECTOR (LINE/PHONO/TUNER/CD/TAPE1/DAT/TAPE2)  
S702 : REC SELECTOR (TUNER/CD/OFF/SOURCE/TAPE1→2/TAPE2→1)

**SCH-2** INPUT ASSY, REC OUT ASSY

INPUT ASSY, REC OUT ASSY **SCH-2**

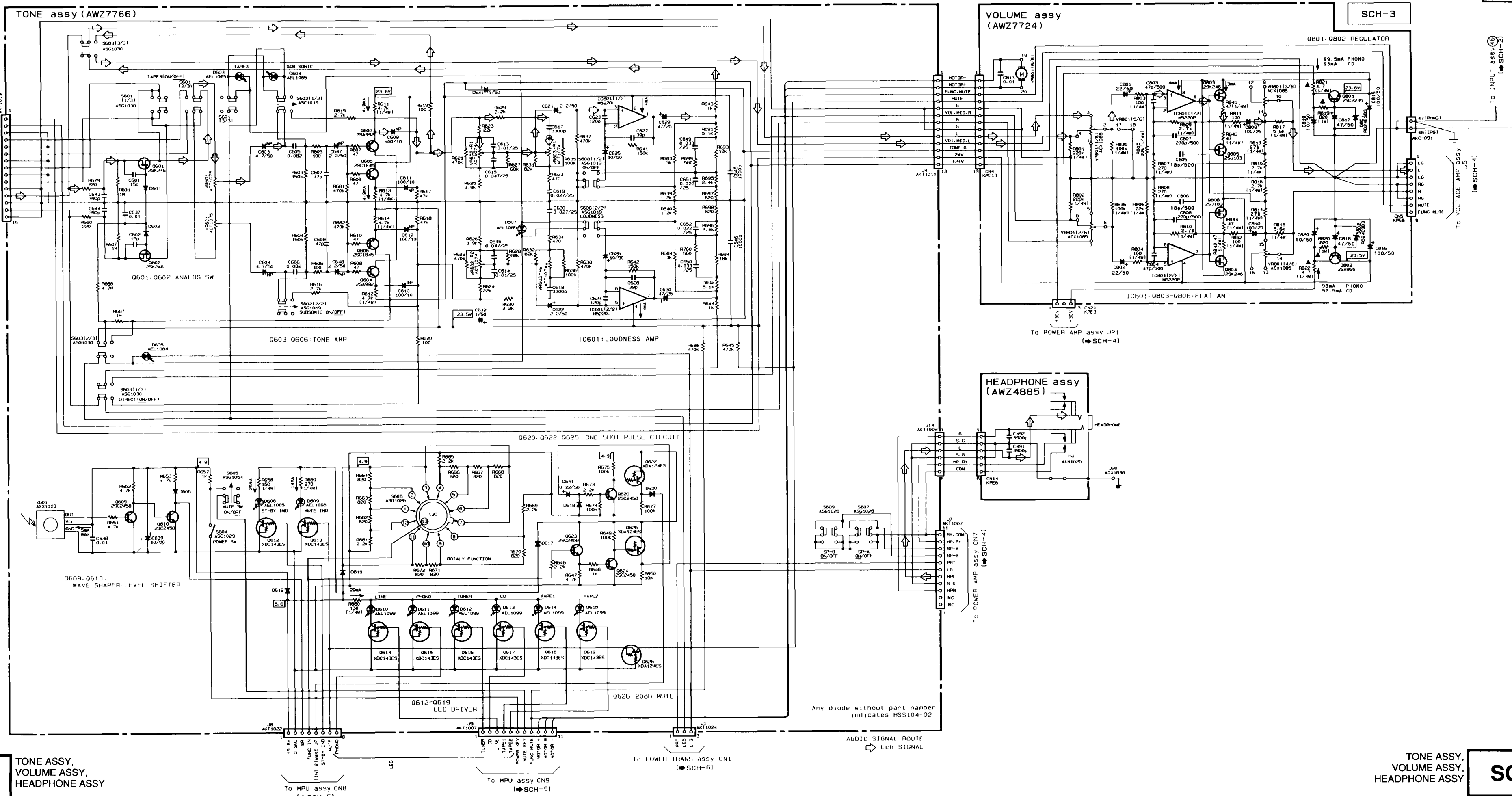

SCH-3

SCH-3

TONE ASSY, VOLUME ASSY, HEADPHONE ASSY

TONE ASSY, VOLUME ASSY, HEADPHONE ASSY

Any diode without part number indicates H55104-02

AUDIO SIGNAL ROUTING Len SIGNAL

To MPU assy CN8 (SCH-5)

To MPU assy CN9 (SCH-5)

To POWER TRANS assy CN1 (SCH-5)

To POWER AMP assy J21 (SCH-4)

To VOLTAGE AMP assy (SCH-4)

To INPUT assy (SCH-2)

To POWER AMP assy (SCH-4)



To POWER SW assy CN2 (SCH-6)

SCH-5

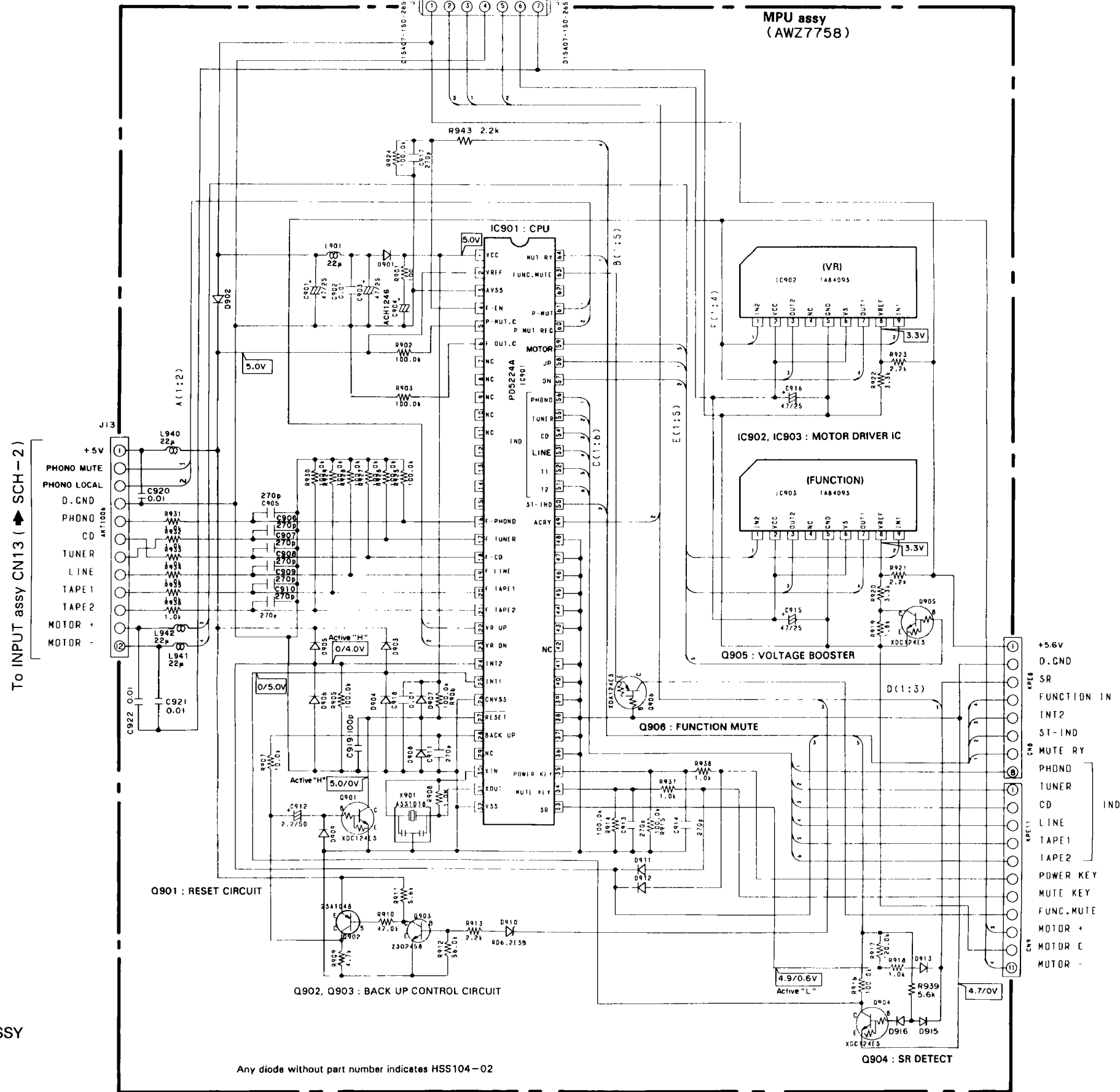

MPU ASSY

MPU ASSY

SCH-5

SCH-5



# ● CONTRAST OF MISCELLANEOUS PARTS

**NOTES:**

- Parts marked by "NSP" are generally unavailable because they are not in our Master Spare Parts List.
- The  $\Delta$  mark found on some component parts indicates the importance of the safety factor of the part. Therefore, when replacing, be sure to use parts of identical designation.
- Parts marked by "●" are not always kept in stock. Their delivery time may be longer than usual or they may be unavailable.

A-705R/HY/EW, HY/GR, SD and A-604R/HE have the same construction except for the following:

Mark	Symbol & Description	Part No.				Remarks
		A-604R	A-705R			
		HE	HY/EW	HY/GR	SD	
NSP	AF ASSY	AWK7172	AWK7304	AWK7304	AWK7306	
	└ POWER AMP ASSY	AWZ7706	AWZ8350	AWZ8350	AWZ8350	
	└ VOLTAGE AMP ASSY	AWZ4895	AWZ8351	AWZ8351	AWZ8351	
NSP	└ REC OUT ASSY	AWZ7842	AWZ8352	AWZ8352	AWZ8352	
NSP	└ DIODE ASSY	AWZ7763	AWZ8353	AWZ8353	AWZ8353	
	└ POWER TRANS ASSY	AWZ7759	AWZ8354	AWZ8354	AWZ8354	
	└ POWER SW ASSY	AWZ7707	AWZ8355	AWZ8355	AWZ8365	
NSP	INPUT ASSY	AWK7180	AWK7305	AWK7305	AWK7305	
NSP	└ HEADPHONE ASSY	AWZ4885	AWZ8357	AWZ8357	AWZ8357	
	└ TONE ASSY	AWZ7766	AWZ8358	AWZ8358	AWZ8358	
	└ INPUT ASSY	AWZ7806	AWZ8359	AWZ8359	AWZ8359	
NSP	CONTROL COMPLEX ASSY	AWP7003	AWP7008	AWP7008	AWP7008	
	└ MPU ASSY	AWZ7758	AWZ8360	AWZ8360	AWZ8360	
	└ VOLUME ASSY	AWZ7724	AWZ8363	AWZ8363	AWZ8363	
$\Delta$	S1 Voltage selector (AC110V/120 - 127V/220V/240V)	Not used	Not used	Not used	AKX - 507 *1	
$\Delta$	S2 Voltage selector (AC110 - 127V/220 - 240V)	Not used	Not used	Not used	AKX1004 *1	
$\Delta$	T1 Power transformer (AC220 - 230V/240V)	ATS1490	ATS7124	ATS7124	Not used	
$\Delta$	T1 Power transformer (AC110V/120 - 127V/220V/240V)	Not used	Not used	Not used	ATS7125	
$\Delta$	AC outlet	AKP - 502	AKP - 502	AKP - 502	AKP - 515	
$\Delta$	FU2 Fuse (2.5A)	Not used	Not used	Not used	AEK - 512 *2	
$\Delta$	AC power cord	ADG1127	ADG1154	ADG1154	ADG1158	
	Scerw	Not used	VBZ30P120FMC	VBZ30P120FMC	VBZ30P120FMC	For insulator
	Rear panel (MET)	ANC7240	ANC7431	ANC7431	ANC2081	
	Insulator	Not used	AMR2622	AMR2622	AMR2622	
	S4 Switch	Not used	ASH - 501 *3	ASH - 501 *3	Not used	On rear panel
	Screw	Not used	BMZ30P080FZK	BMZ30P080FZK	Not used	For S4 switch
NSP	Front panel (MET)	ANB7018	ANB7055	ANB7055	ANB7055	
	Heat sink	ANH1435	ANH7017	ANH7017	ANH7017	
	Sheet	AEE1014	AEE7010	AEE7010	AEE7010	
	Operating instructions (English/French/German/Italian/ Swedish/Dutch/Spanish/Portguese)	ARE7049	ARE7071	Not used	Not used	
	Operating instructions (German)	Not used	Not used	ARC7119	Not used	
	Operating instructions (English/Spanish/Chinese)	Not used	Not used	Not used	ARE7072	
	Side pad L	AHA1600	AHA1658	AHA1658	AHA1658	
	Short pin plug	Not used	AKM - 050	AKM - 050	AKM - 050	Attach to PHONO JACK
	Packing case	AHD7185	AHD7313	AHD7313	AHD7314	
	Packing sheet	AHG1204	AHG7008	AHG7008	AHG7008	

Note \*1 : Refer to "SCH-1" of A-604R/SD in the ARP2890 service manual.

\*2 : Refer to "SCH-6" of A-604R/SD in the ARP2890 service manual.

\*3 : Refer to page4.

**POWER AMP ASSY**

AWZ8350 and AWZ7706 have the same construction except for the following:

Mark	Symbol & Description	Part No.		Remarks
		AWZ7706	AWZ8350	
	C1 (10000µF/56V) C2 (10000µF/56V) C303, C304 Q401, Q402 Q403, Q404  RY401, RY402	ACH1234 ACH1235 CEAS471M6 2SC3298 2SA1306  ASR - 112	ACH7050 ACH7051 CEAS471M6R3 2SC4793 2SA1837  ASR - 109	

**VOLTAGE AMP ASSY**

AWZ8351 and AWZ4895 have the same construction except for the following:

Mark	Symbol & Description	Part No.		Remarks
		AWZ4895	AWZ8351	
	C203 - C206 (220µF/16V) C213, C214 (10µF/50V) C231, C232, C235, C236 (330µF/63V) D201 - D204 R203, R204  R205 - R208 R267 - R270 R271, R272 R275, R276 R293, R294  VR203, VR204 (47kΩ)	CEAS221M16 CEAS100M50 CEAS331M63 AEL1148 RD1/4PM104J  RD1/4PM100J RD1/2PM472J RD1/4PM221J RD1/4PM101J RD1/4PM112J  ACP1045	ACH7052 VCH1130 ACH7053 BR3371XJ30A RDR1/4PM104J  RDR1/4PM100J RDR1/2PM472J RDR1/4PM221J RDR1/4PM101J RDR1/4PM112J  RCP1047	

**REC OUT ASSY**

Although AWZ8352 and AWZ7842 are different in part number, they consist of the same components.

**DIODE ASSY**

AWZ8353 and AWZ7763 have the same construction except for the following:

Mark	Symbol & Description	Part No.		Remarks
		AWZ7763	AWZ8353	
	D595 D596	FMM - 22S FMM - 22R	F10P20F F10P20FR	

**POWER TRANS ASSY**

Although AWZ8354 and AWZ7759 are different in part number, they consist of the same components.

# A-705R

## POWER SW ASSY

AWZ8355, AWZ8365 and AWZ7707 have the same construction except for the following:

Mark	Symbol & Description	Part No.			Remarks
		AWZ7707	AWZ8355	AWZ8365	
IC551 L553		NJM78M56FAS LAU220K	NJM78M56FA LAU220J	NJM78M56FA LAU220J	

POWER SW assy  
(AWZ8355:HY/EW AND HY/GR TYPES)  
(AWZ8365:SD TYPE)

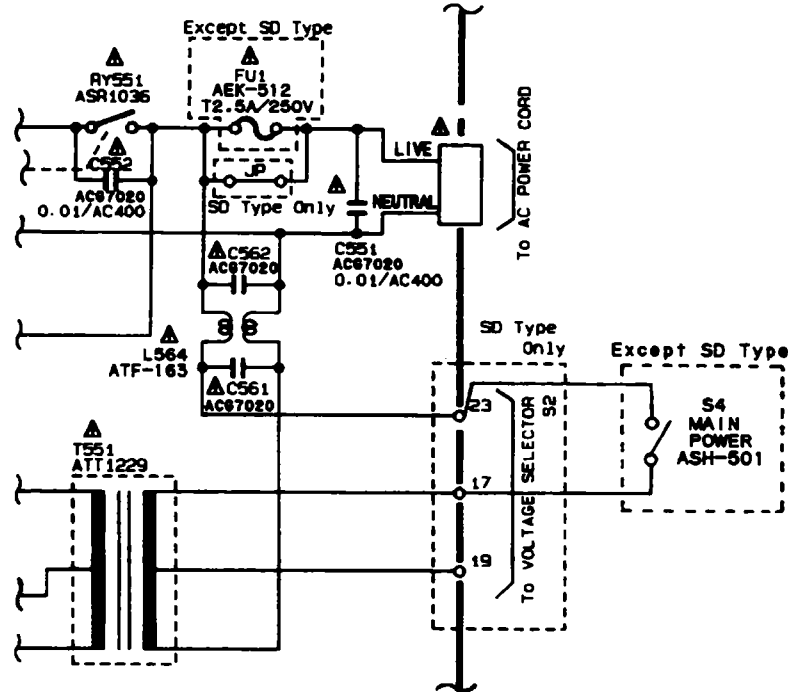

## HEADPHONE ASSY

Although AWZ8357 and AWZ4885 are different in part number, they consist of the same components.

## TONE ASSY

AWZ8358 and AWZ7766 have the same construction except for the following:

Mark	Symbol & Description	Part No.		Remarks
		AWZ7766	AWZ8358	
	C613, C614 C615, C616 C619, C620 C649, C650 C651, C652	CKCYX103M25 CKCYX473M25 CKCYX273M25 CKCYX333M25 CKCYX223M25	CGCYX103M25 CGCYX473M25 CGCYX273M25 CGCYX333M25 CGCYX223M25	
	D610 - D615 S604 Remote receiver unit	AEL1099 ASG1029 AXX1023	BR3371XJ30A ASG1051 GPIU58X	



**INPUT ASSY**

AWZ8359 and AWZ7806 have the same construction except for the following:

Mark	Symbol & Description	Part No.		Remarks
		AWZ7806	AWZ8359	
	C717 - C720 C729 - C732 CN8105 PIN JACK (2P) JA8105 PIN JACK (2P) CN8106 PIN JACK (6P)	CEEA470M25 CEEA100M50 AKB7028 Not used AKB7012	CENA470M25 CENA100M50 Not used DKB1045 AKB7079	For CN8105

**MPU ASSY**

AWZ8360 and AWZ7758 have the same construction except for the following:

Mark	Symbol & Description	Part No.		Remarks
		AWZ7758	AWZ8360	
	L901, L940 - L942	LAU220K	LAU220J	

**VOLUME ASSY**

AWZ8363 and AWZ7724 have the same construction except for the following:

Mark	Symbol & Description	Part No.		Remarks
		AWZ7724	AWZ8363	
	C801, C802 R807, R808 R809, R810 R817, R818	CEAS220M50 RD1/4PM271J RD1/4PM272J RD1/4PM562J	CENA220M25 RDR1/4PM271J RDR1/4PM272J RDR1/4PM562J	