

Service Manual

**CIRCUIT DESCRIPTIONS
REPAIR & ADJUSTMENTS**



**ORDER NO.
ARP-688-0**

STEREO AMPLIFIER

A-88X

MODEL A-88X COMES IN SIX VERSIONS DISTINGUISHED AS FOLLOWS:

Type	Voltage	Remarks	Black	Silver
KU	AC120V only	U.S.A. model	○	—
HE	AC220V, 240V (switchable)	European continent model	○	○
HB	AC220V, 240V (switchable)	United Kingdom model	○	—
S	AC110V, 120V, 220V, 240V (switchable)	General export model	○	—
S/G	AC110V, 120V, 220V, 240V (switchable)	U.S. Military model	○	—
HEZ	AC220V, 240V (switchable)	West Germany model	○	○

- This service manual is applicable to the KU type.
For servicing of the HE, HB, S, S/G, HEZ types, please refer to the additional service manual.
- Ce manuel d'instruction se réfère au mode de réglage, en français.
- Este manual de servicio trata del método de ajuste escrito en español.

CONTENTS

1. SPECIFICATIONS	2	7. P.C. BOARDS CONNECTION DIAGRAM	15
2. FRONT PANEL FACILITIES	3	8. SCHEMATIC DIAGRAM	23
3. PARTS LOCATION	5	9. ELECTRICAL PARTS LIST	27
4. BLOCK DIAGRAM	7	10. PACKING	31
5. EXPLODED VIEW AND PARTS LIST	9	11. SAFETY INFORMATION	32
6. ADJUSTMENT	14		
RÉGLAGE	14		
AJUSTE	14		

PIONEER ELECTRONIC CORPORATION 4-1, Meguro 1-Chome, Meguro-ku, Tokyo 153, Japan
PIONEER ELECTRONICS (USA) INC. P.O. Box 1760, Long Beach, California 90801 U.S.A.
 TEL: (800) 421-1404, (800) 237-0424
PIONEER ELECTRONIC (EUROPE) N.V. Keetberglaan 1, 2740 Beveren, Belgium TEL: 03/775-28-08
PIONEER ELECTRONICS AUSTRALIA PTY. LTD. 178-184 Boundary Road, Braeside, Victoria 3195, Australia
 TEL: (03) 580-9911

1. SPECIFICATIONS

Amplifier Section

Continuous average power output is 120 watts* per channel, min., at 8 ohms from 20 Hertz to 20,000 Hertz with no more than 0.003% total harmonic distortion.

Total Harmonic Distortion

(20 Hz to 20 kHz, 8 Ω, from CD)

120 W per channel power output

..... No more than 0.003%

Cross-harmonic distortion (50 Hz : 7 kHz = 4 : 1)

At effective output 0.003%

Output bandwidth (both channels driven)

..... 5 Hz — 60 kHz (distortion 0.01%, 8 Ω)

Damping Factor (20 Hz to 20 kHz, 8 Ω) 100

Input (Sensitivity/Impedance)

PHONO MM 2.5 mV/50 kΩ

PHONO MC 0.25 mV/40 Ω,

0.15 mV/3 Ω MC transformer

TUNER, CD, AUX 1, 2, TAPE PLAY 1, 2

..... 150 mV/30 kΩ

Phono Overload Level

PHONO MM (T.H.D. 0.003%, 1 kHz) 250 mV

PHONO MC (T.H.D. 0.003%, 1 kHz)

Input sensitivity 0.25 mV 40 Ω 22 mV

Input sensitivity 0.15 mV 3 Ω 13 mV

Cartridge load capacity/load impedance

PHONO MM 220 pF/50 kΩ

Output (Level/Impedance)

TAPE REC 1, 2 150 mV/2.2 kΩ

Frequency Response

PHONO (RIAA Equalization) MM, MC

..... 20 Hz to 20 kHz ±0.2 dB

TUNER, CD, AUX 1, 2, TAPE PLAY 1, 2

..... 10 Hz — 100 kHz ± $\frac{1}{3}$ dB

Tone Control

BASS ±8 dB (100 Hz)

TREBLE ±8 dB (10 kHz)

SUBSONIC filter 15 Hz (-6 dB/oct)

Muting -20 dB

Hum and Noise (short circuited, A network)

PHONO MM 89 dB

PHONO MC 76 dB (3/40 Ω)

CD, AUX 1, 2, TUNER,

TAPE PLAY 1, 2 110 dB

Speaker load impedance

HE, HB, YP models 6 — 16 Ω

KU, KC, S, S/G models 4 — 16 Ω

Miscellaneous

Power Requirements

HE model a.c. 220 V ~, 50/60 Hz

HB, YP models a.c. 240 V ~, 50/60 Hz

S, S/G models ~AC 110 V/120 V/220 V/240 V

(switchable), 50/60 Hz

KU, KC models AC 120 V, 60 Hz

Power Consumption

KU model 670 W (UL)

KC model 820 VA (CSA)

Dimensions 457 (W) x 155 (H) x 427 (D) mm

18 (W) x 6-1/8 (H) x 16-3/4 (D) in

Weight (without package) 18 kg (39 lb 10 oz)

Furnished Parts

Operating Instructions 1

Side Panel 2

Side Panel mount screw 4

NOTE:

- Specifications and design subject to possible modification without notice due to improvements.
- *Measured pursuant to the Federal Trade Commission's Trade Regulation rule on Power Claims for Amplifiers.

2. FRONT PANEL FACILITIES

FRONT PANEL

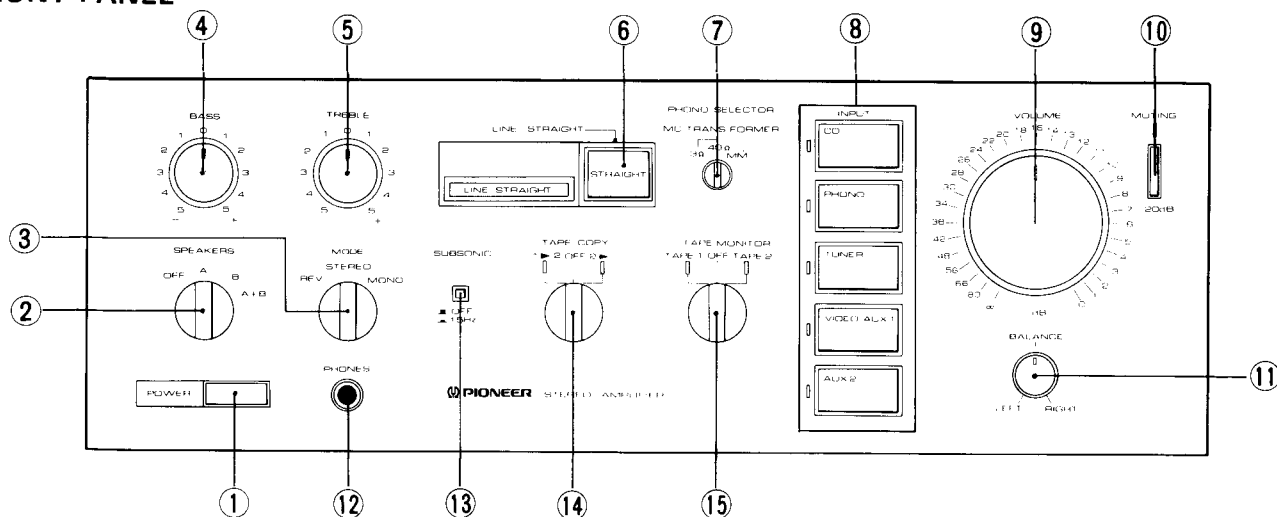

① POWER switch/indicator

Press to turn power to the unit ON and OFF.
 Depressed position (ON): Power is supplied to the unit.
 Released position (OFF): Power to the unit is disconnected.

② SPEAKERS selector switch

Use to select the speaker systems used for playback.
 [OFF]

— No sound is produced from the speaker systems. Set to this position when using headphones.

[A]

— Sound is produced from the speaker systems connected to the SPEAKERS A terminals.

[B]

— Sound is produced from the speaker systems connected to the SPEAKERS B terminals.

[A + B]

— Sound is produced from both the speaker systems connected to the SPEAKERS A and SPEAKERS B terminals.

③ MODE selector switch

Use to select the playback mode.
 [STEREO]

— Set here for normal stereo reproduction.

The left-channel sound (signals connected to the rear panel L terminals) will be produced from the left-side speaker systems, and right-channel sound (signals connected to the rear panel R terminals) will be produced from the right-side speaker systems.

[REV]

— When set to this position, the stereo channels will be reversed, the left-channel sound being produced from the right side speaker systems, and the right-channel sound being produced from the left-side speaker systems.

[MONO]

— The left-channel and right-channel signals will be mixed and produced from the right and left side speaker systems simultaneously.

This function does not operate when the LINE STRAIGHT switch is in the ON position.

④ BASS tone control

Use to adjust the low-frequency tones. The central "0" position is the flat (normal) position. When turned to the right, low-frequency tones are emphasized; when turned to the left, low-frequency tones are de-emphasized. This function does not operate when the LINE STRAIGHT switch is in the ON position.

⑤ TREBLE tone control

Use for adjusting the high-frequency tones. The central "0" position is the flat (normal) position. When turned to the right, high-frequency tones are emphasized; when turned to the left, high-frequency tones are de-emphasized. This function does not operate when the LINE STRAIGHT switch is in the ON position.

⑥ LINE STRAIGHT switch/indicator

By using this switch, the input signals from the various connected peripheral components can be played back through the amplifier's modifying (tone, mode) circuits, or bypassing those circuits.

When the indicator is lighted, the function is ON. Input signals will bypass the modifying circuits and be played back with pure, flat-balanced tone.

When set to OFF, input signals will pass through the modifying circuits before being played back, thus allowing you to adjust bass and treble tone, and select the mode of playback with the MODE selector switch.

⑦ PHONO SELECTOR switch

Set in accordance with the type of cartridge used in your turntable.

[MC TRANSFORMER]

— When using an MC (moving coil) cartridge, set either to the [3 Ω] or [40 Ω] position. The 3 ohm and 40 ohm selection should be made on the basis of the cartridge's load resistance (impedance) value.

[MM]

- Set to this position when using an MM (moving magnet) cartridge, or an MC (moving coil) cartridge with high output of 1 mV or more.

⑧ FUNCTION switches/indicators

[CD]

- Press when listening to a compact disc playback with a CD player.

[PHONO]

- Press when listening to record playback on a turntable.

[TUNER]

- Press when listening to AM or FM broadcasts with a tuner.

[VIDEO/AUX 1]

- Press when listening to programs from a component connected to the VIDEO SOUND/AUX 1 terminals.

[AUX 2]

- Press when listening to programs from a component connected to the AUX 2 terminals.

⑨ VOLUME control

These are used for controlling the sound volume.

When set to the [∞] position, sound volume is turned off; when set to the [0] position, sound volume is at a maximum.

⑩ MUTING switch/indicator

Use to temporarily cut sound volume.

When pressed ON, indicator will light, and sound volume will be cut by 20 dB. When set to OFF, the sound will return to its previous volume.

⑪ BALANCE control

Should normally be left in the center position. Adjust balance if the sound is louder from one of the speakers. If the right side is louder, turn toward the (L) position and if the left side is louder, turn toward the (R) position.

⑫ PHONES jack

When using headphones, insert their plug into this jack.

⑬ SUBSONIC filter switch

Use this switch when playing records with coarse grooves.

[OFF]

- Released position; leave in this position for normal playback.

[15Hz]

- Depressed position; in this position, frequencies of 15Hz and below are cut, thus eliminating super-low-frequency noise caused by coarse record grooves, and thus helping prevent sound distortion.

⑭ TAPE COPY switch/indicator

Use when performing tape copying between two tape decks connected to the amplifier.

[1 ► 2]

- Set in this position when performing tape copying from the tape deck connected to the TAPE 1 PLAY terminals to the deck connected to the TAPE 2 REC terminals.

[OFF]

- Leave set in this position when not performing tape copying.

[2 ► 1]

- Set in this position when performing tape copying from the tape deck connected to the TAPE 2 PLAY terminals to the deck connected to the TAPE 1 REC terminals.

⑮ TAPE MONITOR switch/indicator

Use this switch to listen to tape playback, or to listen to the sounds being recorded during tape recording.

[TAPE 1]

- Set to this position to listen to the playback sound of the tape deck connected to the TAPE 1 PLAY terminals, or to monitor the sound being recorded on the tape deck connected to the TAPE 1 REC terminals.

[OFF]

- Leave set in this position when not listening to tape playback.

[TAPE 2]

- Set to this position to listen to the playback sound of the tape deck connected to the TAPE 2 PLAY terminals, or to monitor the sound being recorded on the tape deck connected to the TAPE 2 REC terminals.

Accessories

Wood-grain side panel x 2

Side panel mount screw x 4

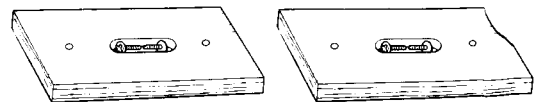

3. PARTS LOCATION

NOTES:

- Parts without part number cannot be supplied.
- The  mark found on some component parts indicates the importance of the safety factor of the part. Therefore, when replacing, be sure to use parts of identical designation.
- For your Parts Stock Control, the fast moving items are indicated with the marks **★★** and **★**.
★★ GENERALLY MOVES FASTER THAN ★.
 This classification shall be adjusted by each distributor because it depends on model number, temperature, humidity, etc.

Front Panel View

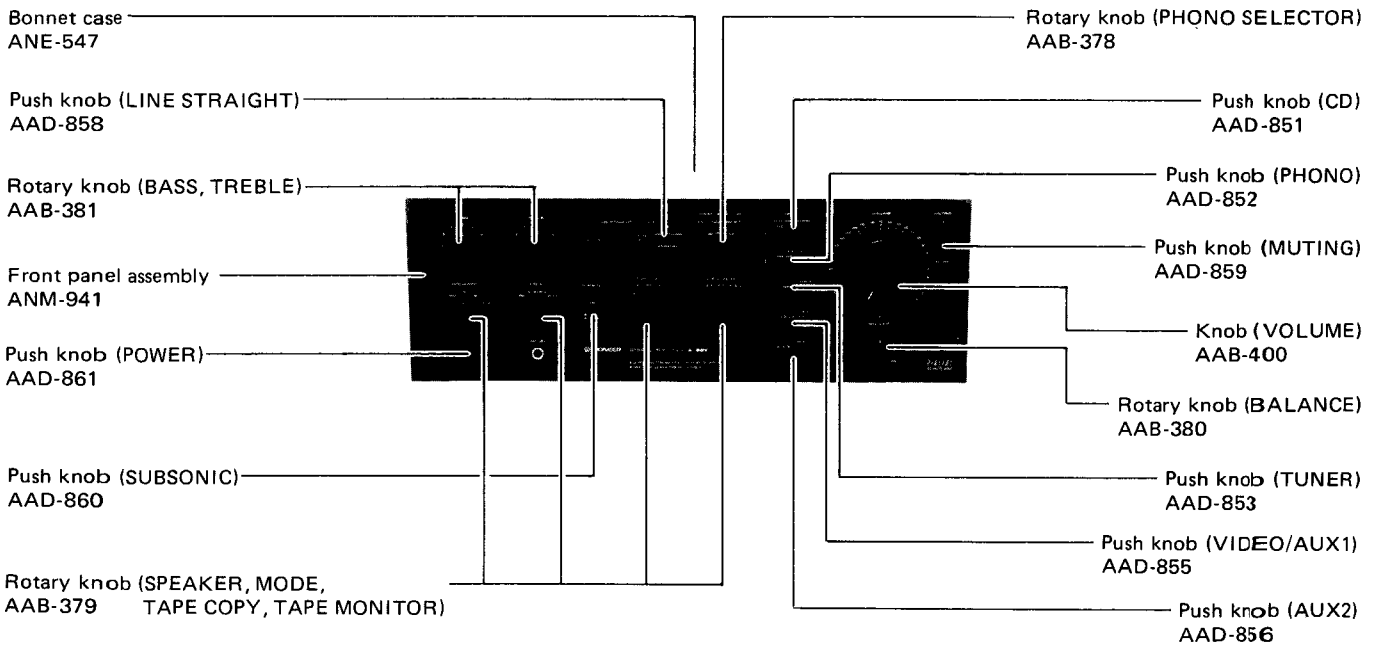

Front View with Panel Removed

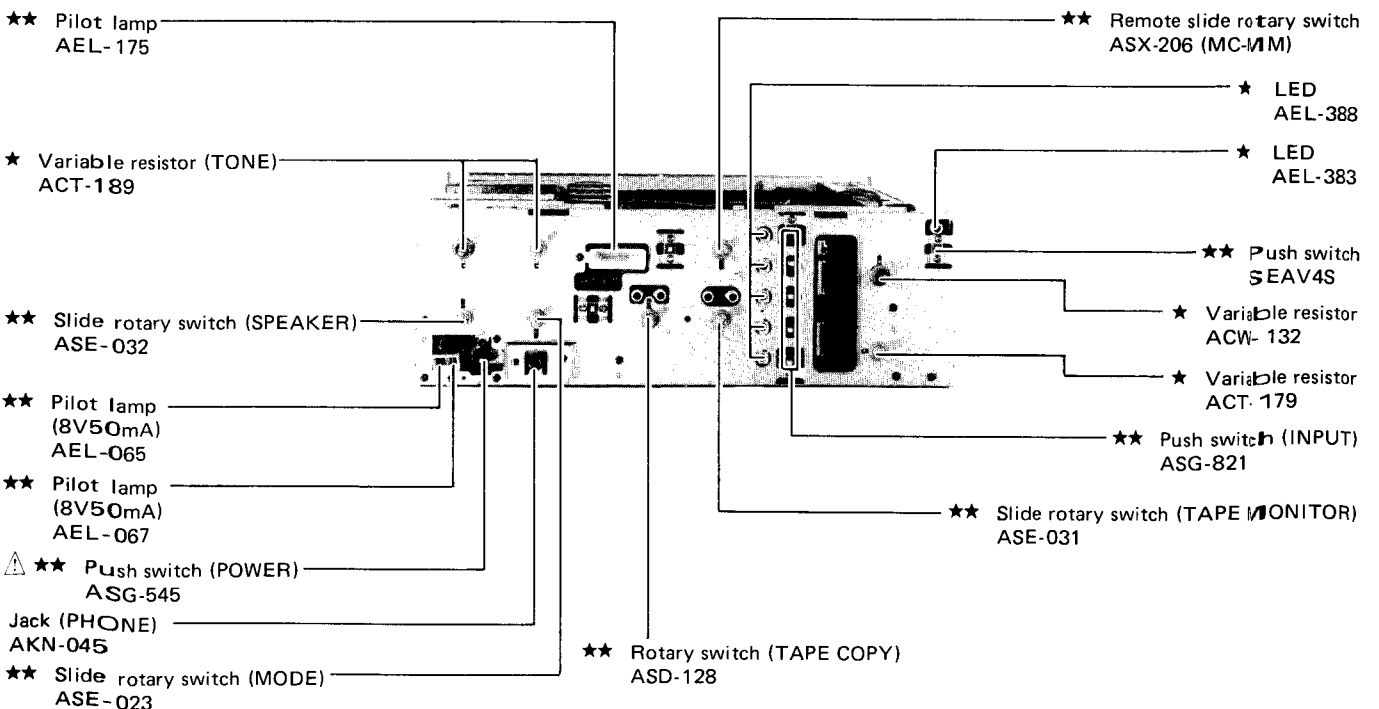

Rear Panel View

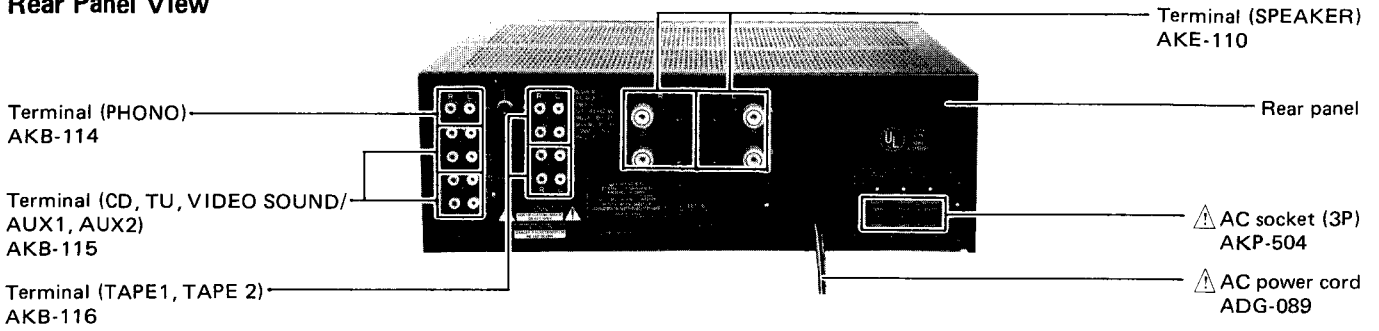

Top View

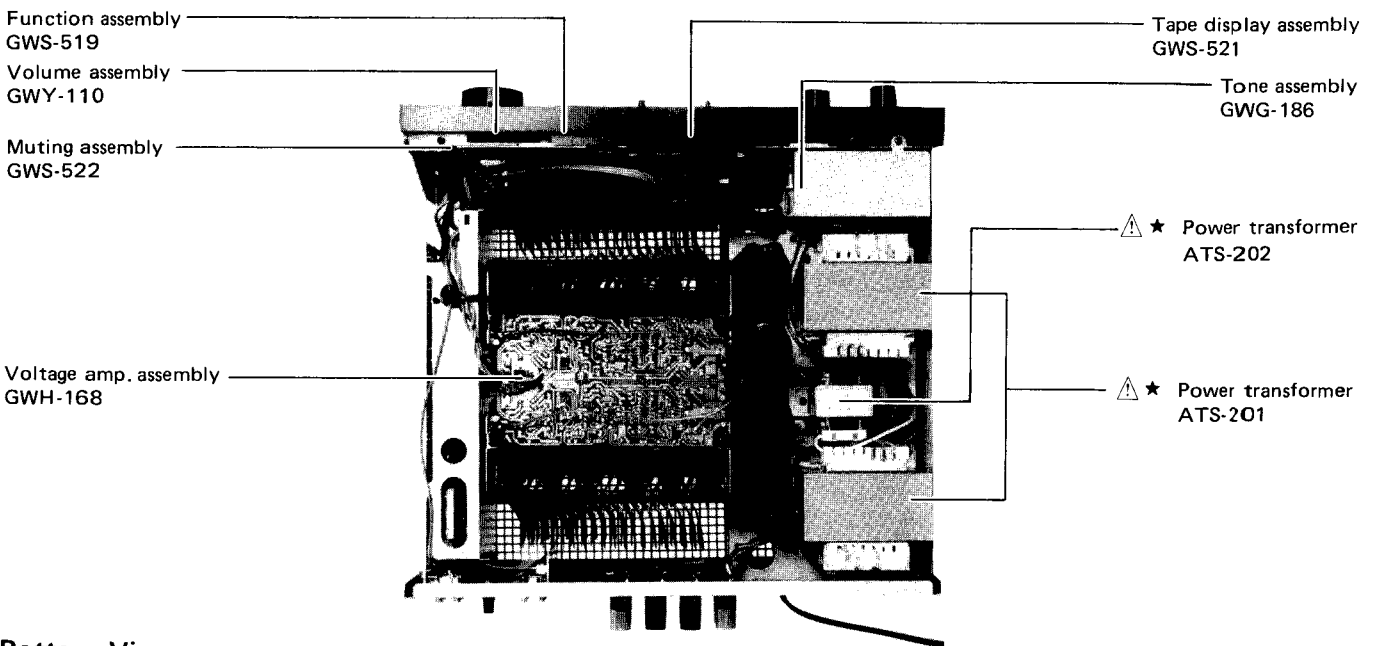

Bottom View

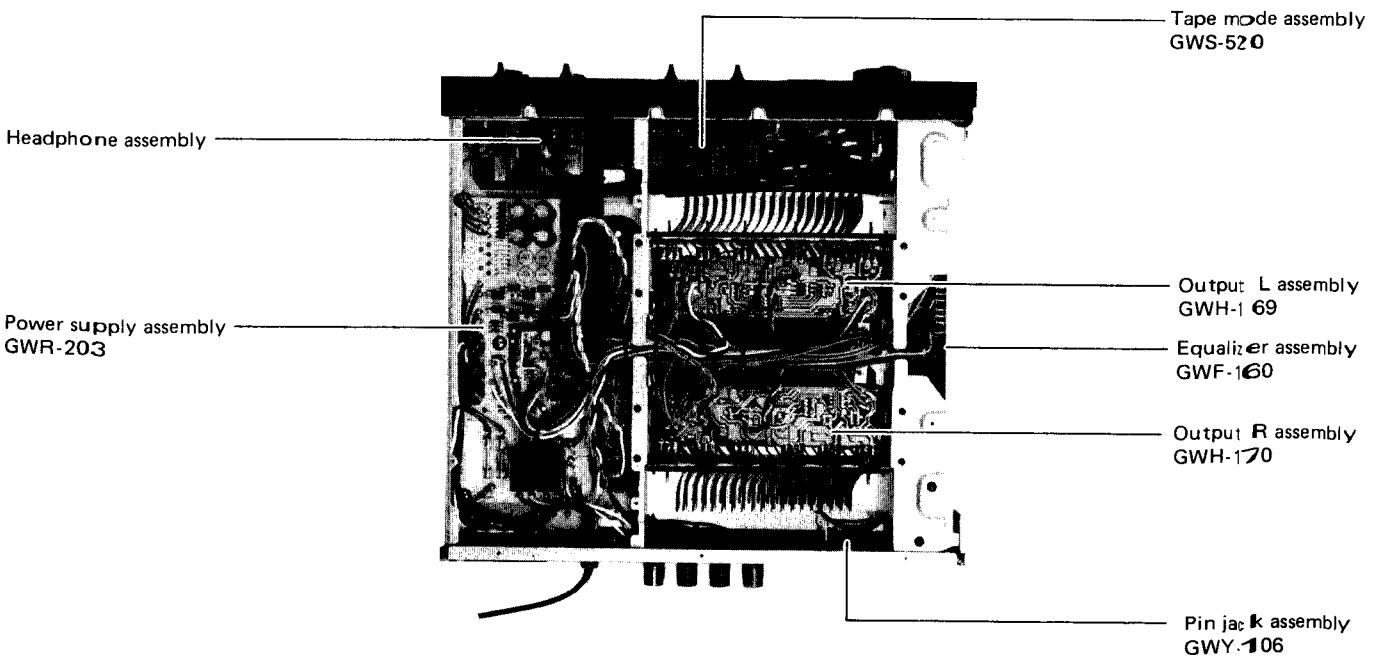

4. BLOCK DIAGRAM

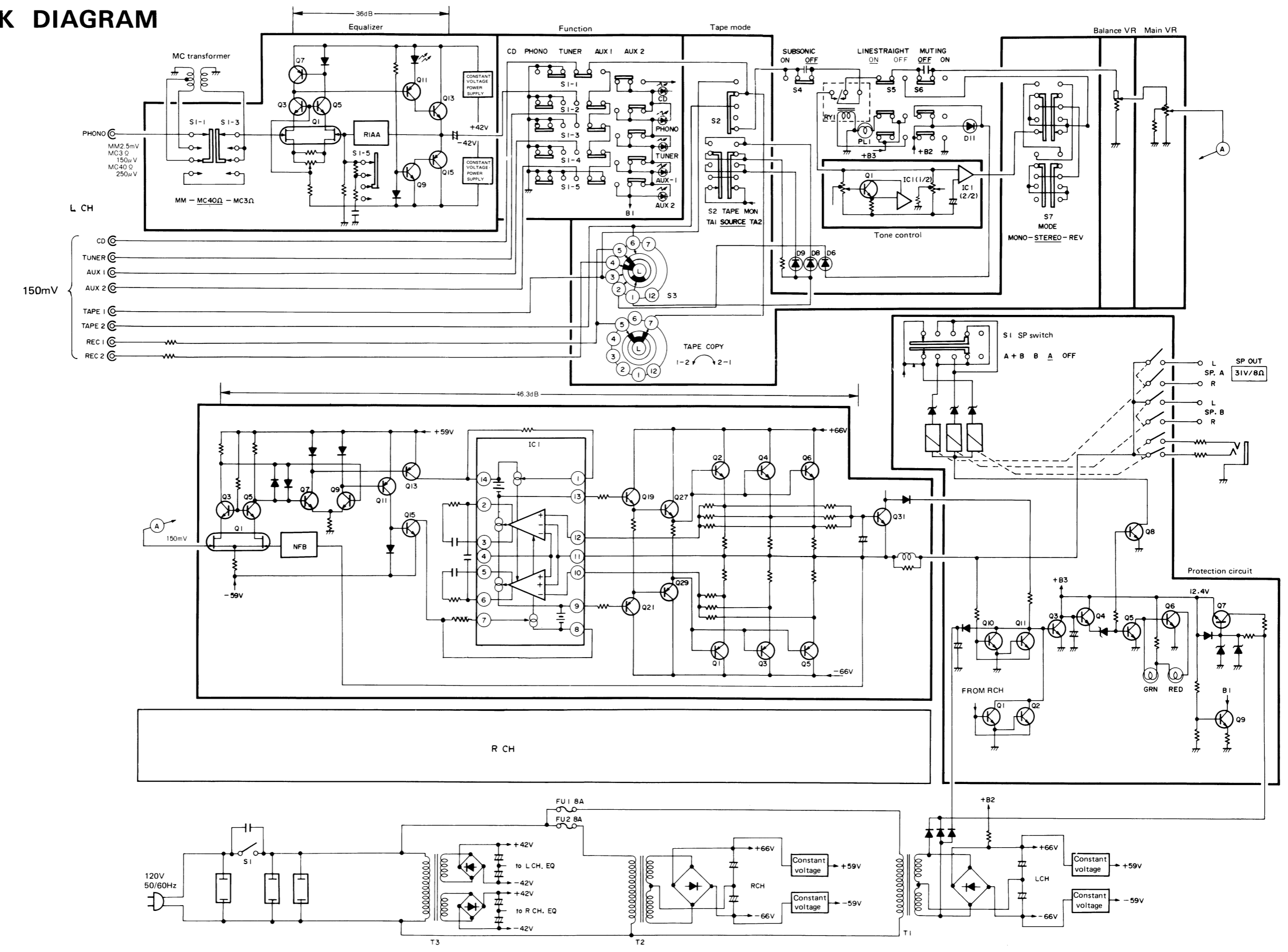

5. EXPLODED VIEWS AND PARTS LIST

Exterior

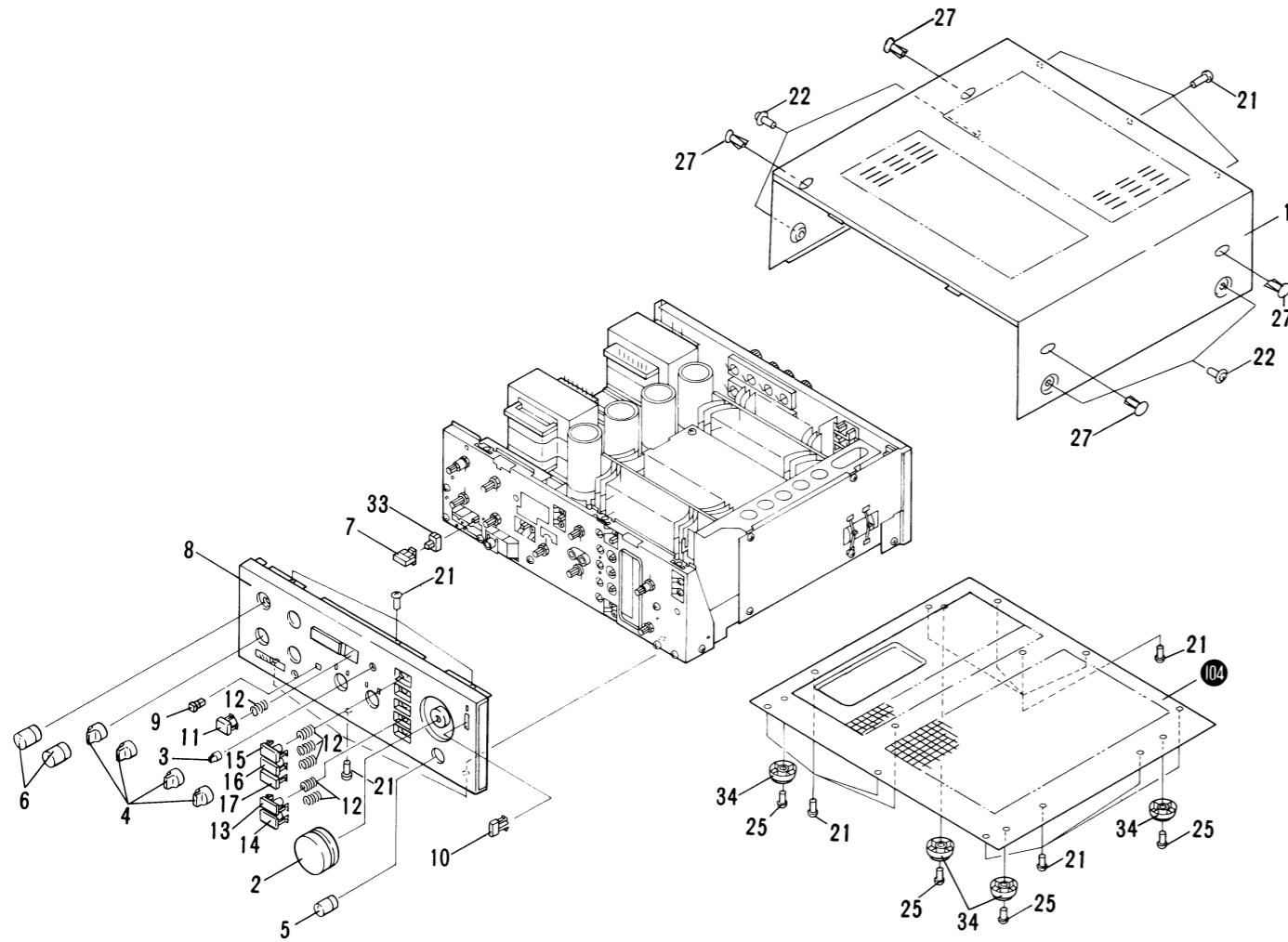

NOTES:

- Parts without part number cannot be supplied.
- The Δ mark found on some component parts indicates the importance of the safety factor of the part. Therefore, when replacing, be sure to use parts of identical designation.
- For your Parts Stock Control, the fast moving items are indicated with the marks $\star\star$ and \star .
 $\star\star$ GENERALLY MOVES FASTER THAN \star .
 This classification shall be adjusted by each distributor because it depends on model number, temperature, humidity, etc.

Mark	No.	Part No.	Description	Mark	No.	Part No.	Description
	1.	ANE-547	Bonnet case		46.	GWR-203	Power supply assembly
	2.	AAB-400	Knob (VOLUME)		47.	ACN-190	Sement resistor
	3.	AAB-378	Rotary knob (PHONO-SELECTOR)		48.	ACE-216	Capacitor (0.1/AC125V)
	4.	AAB-379	Rotary knob	Δ \star	49.	ACH-106	Electrolytic capacitor (10000/71V)
	5.	AAB-380	Rotary knob (BALANCE)		50.	ATS-201	Power transformer (T1, T2)
	6.	AAB-381	Rotary knob (BASS, TREBLE)	Δ \star	51.	ATS-202	Power transformer (T3)
	7.	AAD-861	Push knob (POWER)		52.	AKE-110	Terminal (SPEAKER)
	8.	ANM-941	Front panel	Δ	53.	AKP-504	AC socket 3P
	9.	AAD-860	Push knob (SUBSONIC)	Δ $\star\star$	54.	ASG-545	Push switch (POWER)
	10.	AAD-859	Push knob (MUTING)	$\star\star$	55.	ASX-206	Remote slide rotary switch (MC-MM)
	11.	AAD-858	Push knob (LINE STRAIGHT)	Δ $\star\star$	56.	AEK-304	Fuse (FU1, FU2)
	12.	ABH-135	Spring	$\star\star$	57.	AEL-065	Pilot lamp (Blue lead)
	13.	AAD-855	Push knob (VIDEO/AUX1)	$\star\star$	58.	AEL-067	Pilot lamp (Black lead)
	14.	AAD-856	Push knob (AUX2)		102.		Nylon rivet
	15.	AAD-851	Push knob (CD)		103.		Front stay
	16.	AAD-852	Push knob (PHONO)		104.		Bottom plate
	17.	AAD-853	Push knob (TUNER)		105.		Plate
Δ	18.	ADG-089	AC Power cord		106.		Shield cover
	19.	ABA-283	Screw		107.		Shield plate
	20.	ABN-028	Special nut		108.		Rear panel
	21.	BBZ30P080FZK	Screw		109.		Right frame
	22.	FBT40P080FZK	Screw		110.		Transformer frame
	23.	NK90FUC	Nut		111.		Power switch holder
	24.	VMZ30P060FMC	Screw		112.		Lamp holder A
	25.	VTZ40P080FMC	Screw		113.		Binder
	26.	WA35F100N080	Screw (PT)		114.		Mount plate
	27.	AEP-211	Nylon rivet		115.		Switch assembly
	28.					
	29.					
	30.	AEC-716	Lamp cap (Green)		116.		Headphone assembly
	31.	AEC-783	Lamp cap (Red)		117.		Terminal (GND)
	32.					
	33.	AEC-800	Flexible ring				
	34.	AEP-251	Leg assembly				
	35.	GWF-160	Equalizer assembly				
	36.	GWY-106	Pin jack assembly				
	37.	GWS-519	Function assembly				
	38.	GWS-520	Tape mode assembly				
	39.	GWS-521	Tape display assembly				
	40.	GWS-522	Muting assembly				
	41.	GWG-186	Tone assembly				
	42.	GWY-110	Volume assembly				
	43.	GWH-168	Voltage amplification assembly				
	44.	GWH-169	Output L assembly				
	45.	GWH-170	Output R assembly				

Interior

Heat Sink

A

A

B

B

C

C

D

D

This diagram illustrates the assembly of a server chassis. It shows the following components and their assembly locations:

- Power Supplies:** Two power supplies (part 50) are mounted in the top-left section.
- Fans:** Three fans (part 25) are mounted in the top-middle section.
- Heat Sink:** A heat sink (part 36) is mounted on a component in the middle-right section, with a note "Heat sink see page 13".
- Chassis Panels:** The front panel (part 46) and rear panel (part 44) are shown in their respective positions.
- Internal Components:** Various internal modules (parts 105, 106, 107, 108, 109, 110, 111, 112, 113, 114, 115, 116, 117) are shown being inserted into the chassis.
- Connectors and Cables:** A connector (part 53) and a cable (part 18) are shown connected to the rear panel.
- Fasteners:** Numerous screws (part 21) and other fasteners (parts 20, 23, 24, 26, 27, 28, 29, 30, 31, 32, 33, 34, 35, 37, 38, 39, 40, 41, 42, 43, 45, 47, 48, 49, 51, 52, 54, 55, 56, 57, 58) are shown being used to secure the components.

Parts List of

Mark	No.	Pa
	1.	A
	2.	B
	3.	A
▲	★ 4.	2S
▲	★ 5.	2S
	50.	
	51.	
	52.	

12

Heat Sink

A
B
C
D

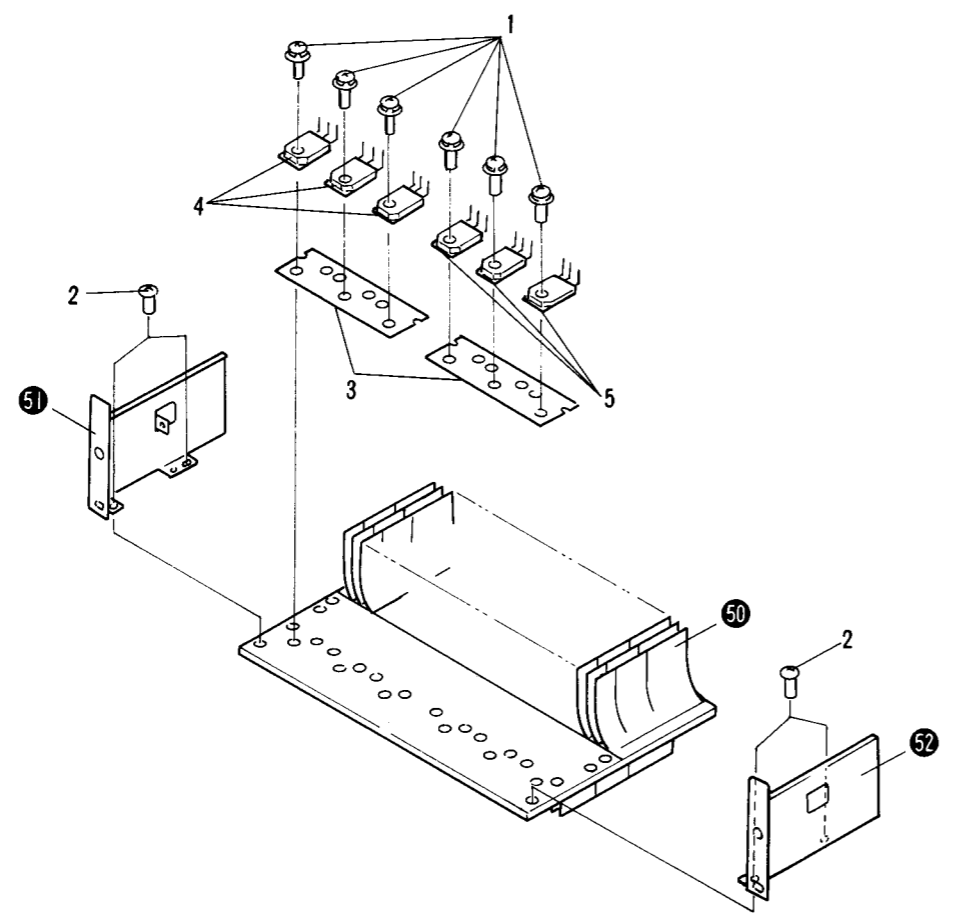

Parts List of Heat Sink

Mark	No.	Part No.	Description
	1.	ABA-282	Screw
	2.	BBZ30P080FZK	Screw
	3.	AEP-136	Mica sheet
▲	★★ 4.	2SA1265NP(A)-O/R*	Power transistor
▲	★★ 5.	2SC3182NP(A)-O/R*	Power transistor
	50.		Heat sink
	51.		Heat sink holder L
	52.		Heat sink holder R

*hfe should have the same value.

6. ADJUSTMENT

Equalizer Adjustment

1. Short the PHONO terminal.
2. Adjust VR1 so that the voltage of TP1 is ± 100 mV or less.
3. Adjust VR2 so that the voltage of TP2 is ± 100 mV or less.

6. RÉGLAGE

Réglage d'égalisateur

1. Court-circuite el terminal PHONO.
2. Ajuste el VR1 de modo que la tensión de TP1 sea ± 100 mV o menos.
3. Ajuste el VR2 de modo que la tensión de TP2 sea ± 100 mV o menos.

6. AJUSTE

Ajuste del igualador

1. Mettre la borne PHONO en court-circuit.
2. Régler VR1 de façon à ce que la tension de TP1 soit de ± 100 mV ou moins.
3. Régler VR2 de façon à ce que la tension de TP2 soit de ± 100 mV ou moins.

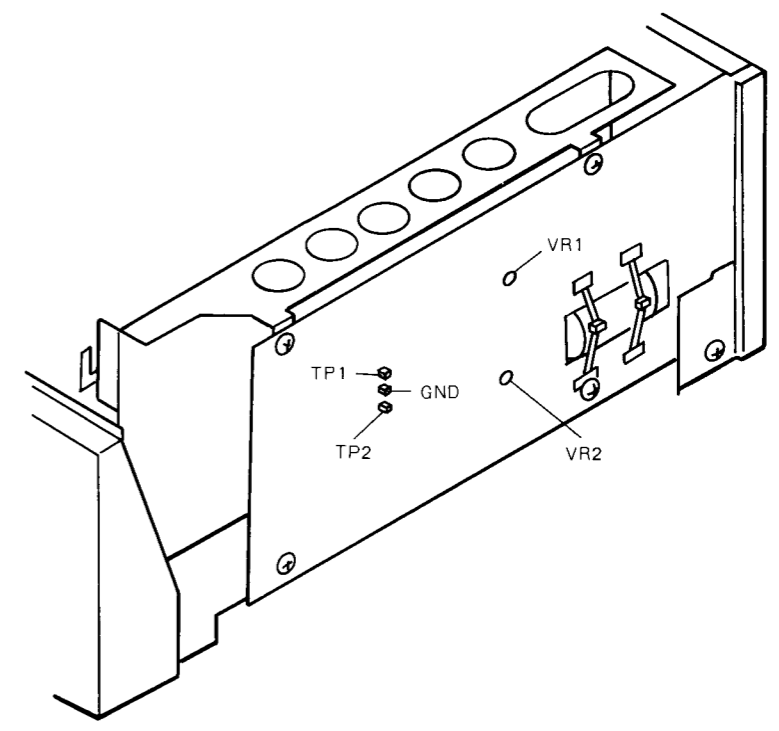

7. P.C. BOARDS CONNECTION DIAGRAM

A
B
C
D

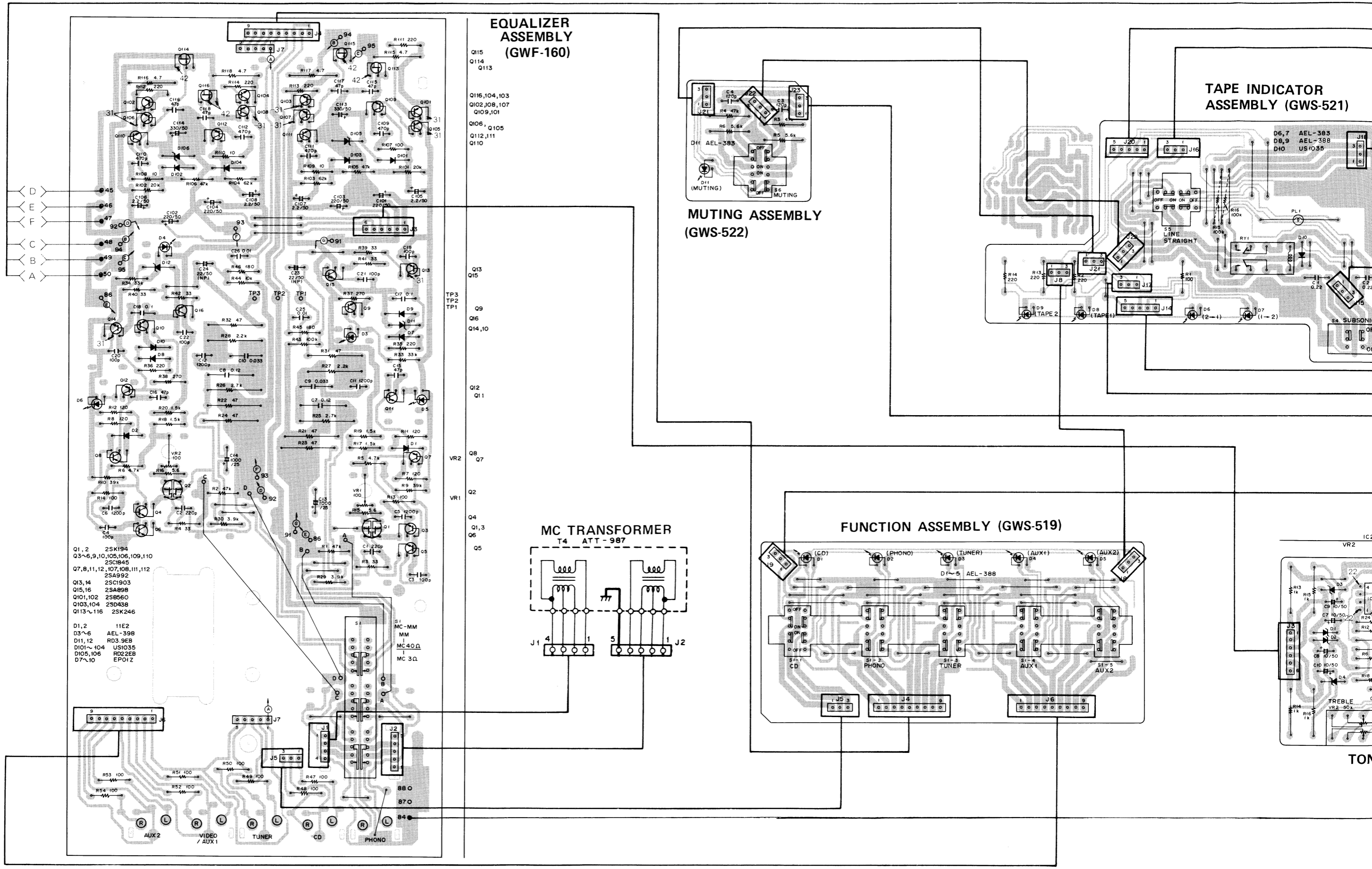

EQUALIZER ASSEMBLY (GWF-160)

Q115
Q114
Q113

Q116, 104, 103
Q102, 108, 107
Q109, 101

Q106, Q105
Q112, 111
Q110

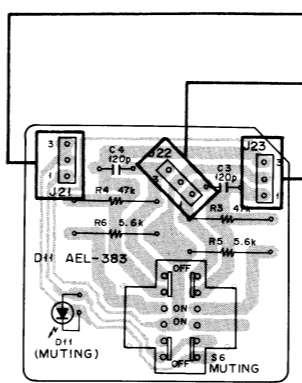

MUTING ASSEMBLY (GWS-522)

TAPE INDICATOR ASSEMBLY (GWS-521)

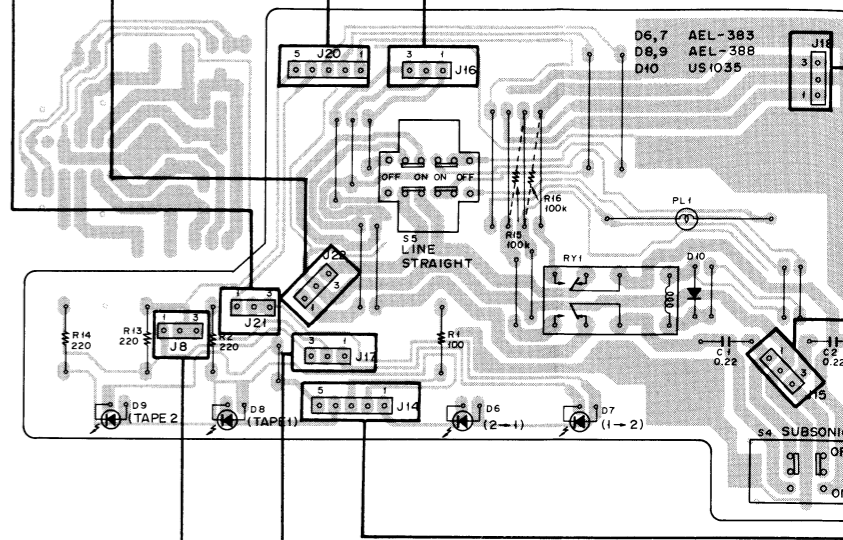

MC TRANSFORMER T4 ATT-987

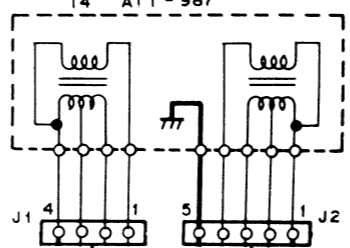

FUNCTION ASSEMBLY (GWS-519)

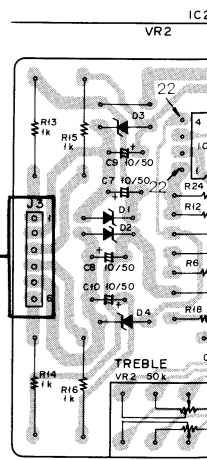
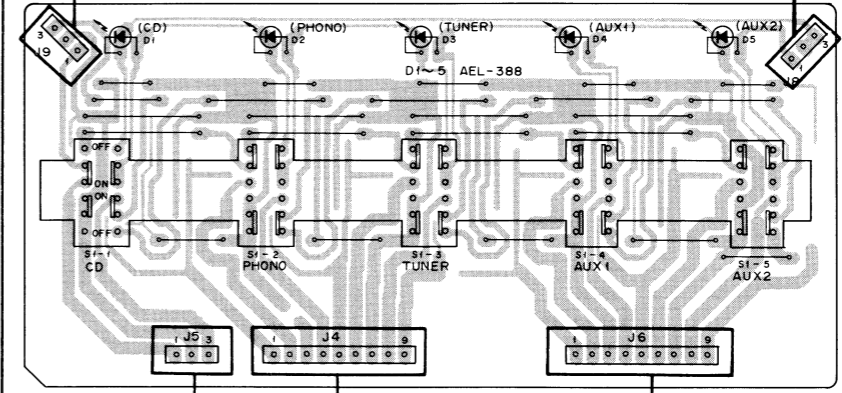

7

8

9

10

11

12

A

B

A

B

C

D

E

F

C

D

TAPE INDICATOR ASSEMBLY (GWS-521)

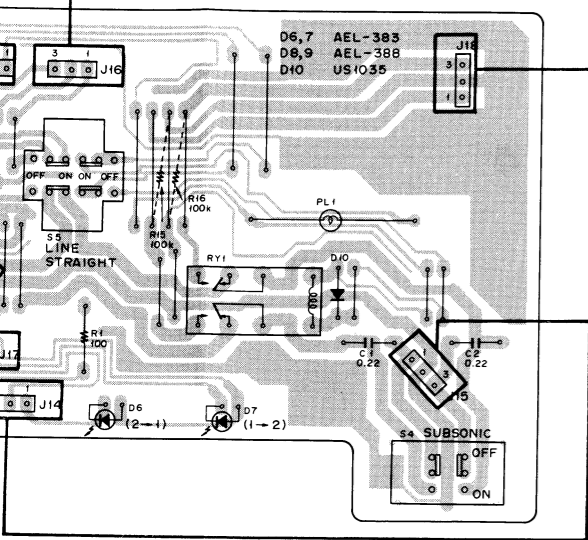

TAPE MODE ASSEMBLY (GWS-520)

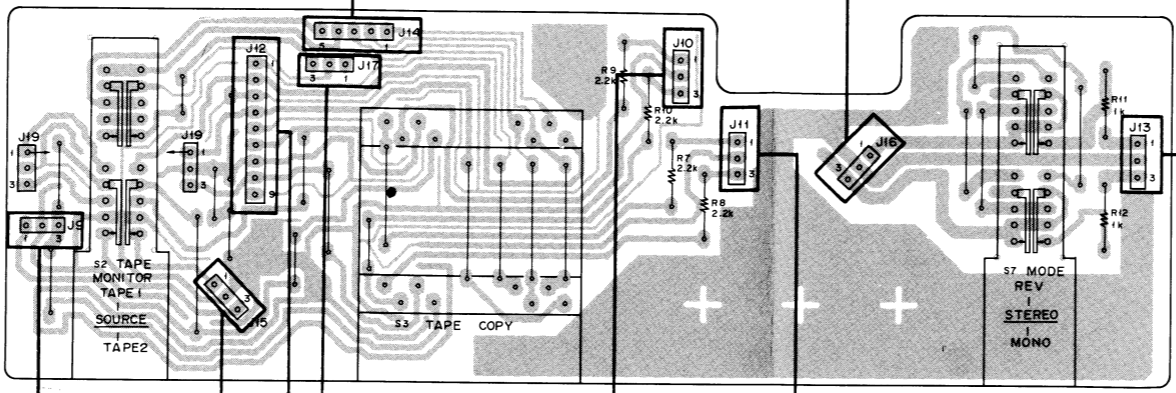

VOLUME ASSEMBLY (GWY-110)

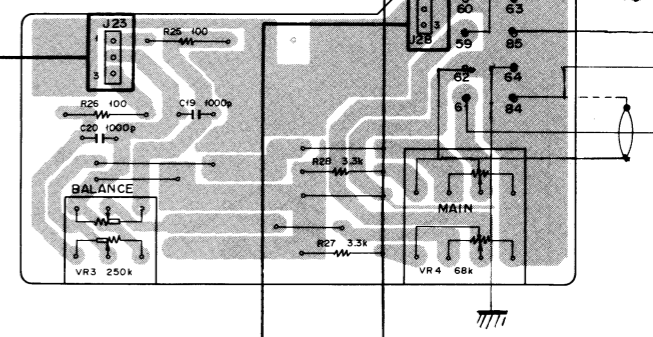

TONE ASSEMBLY (GWG-186)

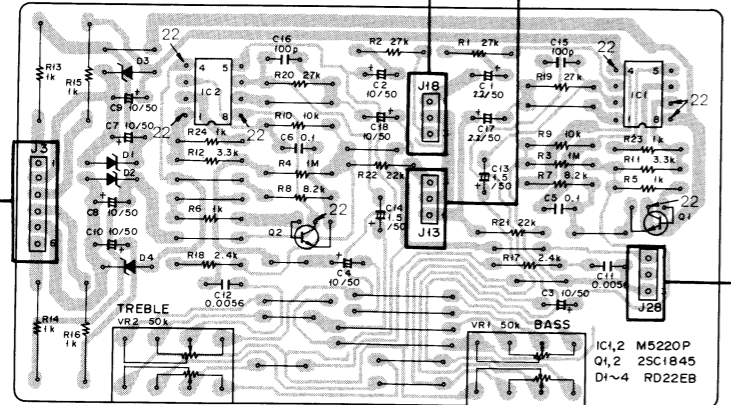

PIN JACK ASSEMBLY (GWY-106)

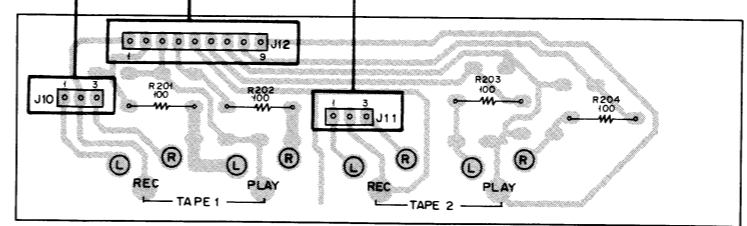

1

2

3

4

5

6

A

B

A

B

C

D

E

C

D

VOLTAGE AMPLIFIER ASSEMBLY (GWH-168)

Q5 Q3 Q9 Q11 Q15 Q21 Q25
 Q6 Q2 Q4 Q10 Q12 Q14 Q16 Q18 Q20 Q22 Q23 Q24 Q26

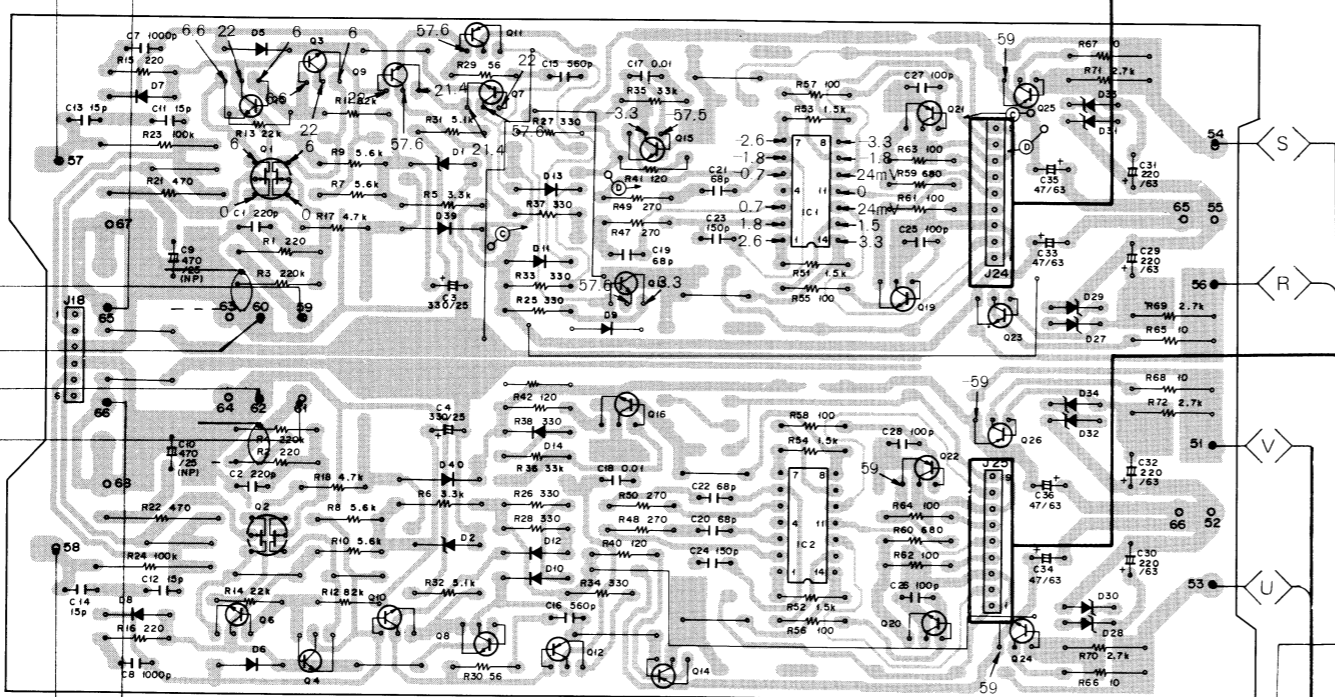

IC1,2	PA0016	Q13,14,24,22	2SA1145(A)	D1,2,27-34	RD20EB
Q1,2	2SK129A	Q15,16,19,20	2SC2705(A)	D9-14	11E2
Q3-10	2SC1845	Q25,26	2SB560	D5-8	US1035
Q11,12	2SA992	Q23,24	2SD438	D39,40	10YD45AFD

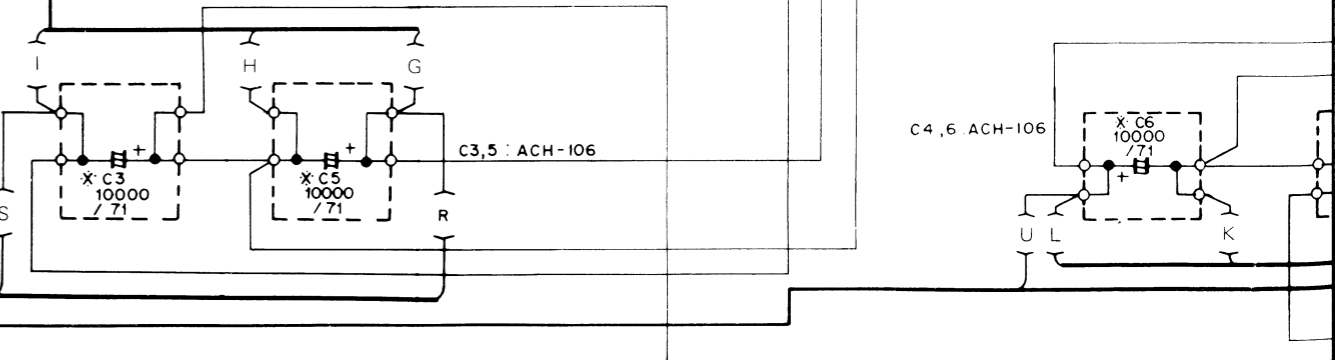
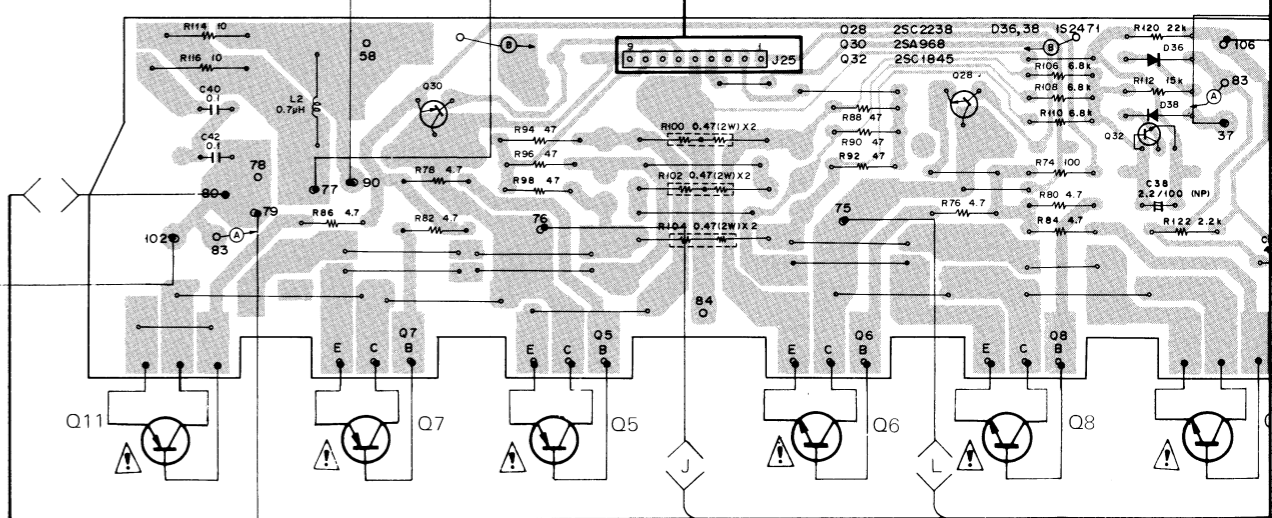
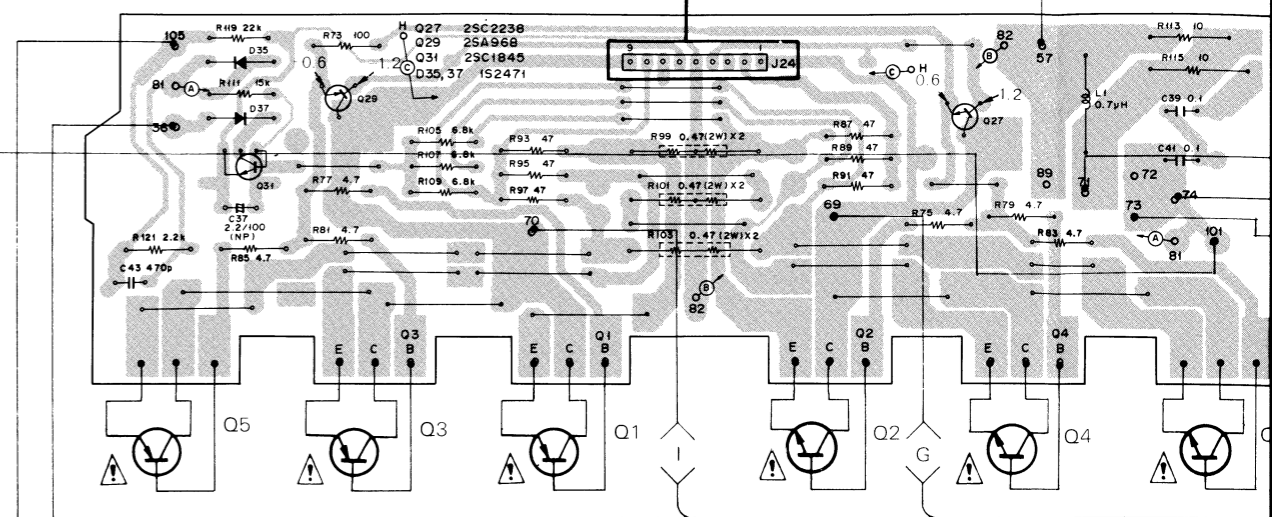

1

2

3

4

5

6

6

7

8

9

10

11

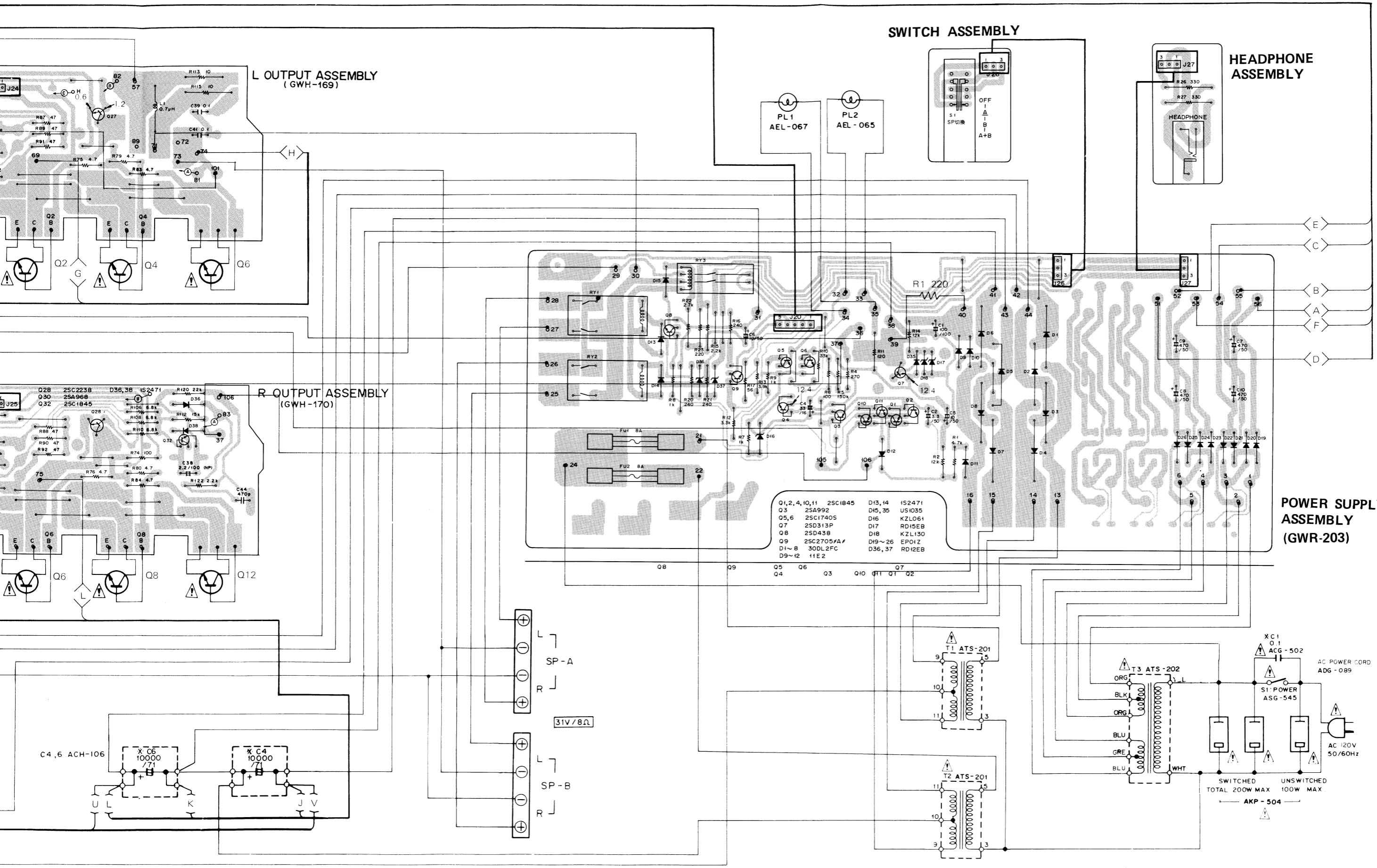

A

B

C

D

6

7

8

9

10

11

12

8. SCHEMATIC DIAGRAM

A

B

C

D

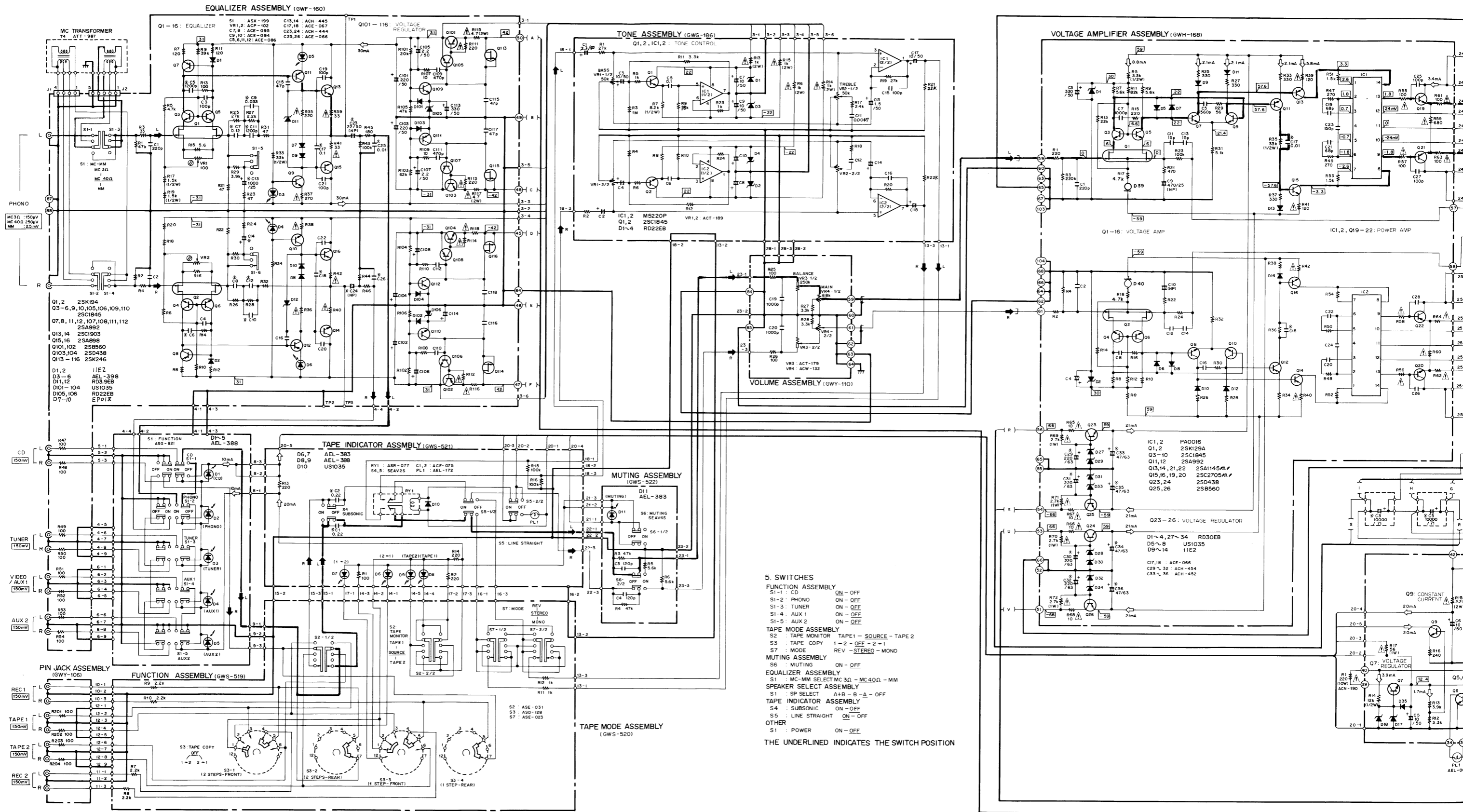

- 5. SWITCHES**
- FUNCTION ASSEMBLY**
 S1-1: CD ON - OFF
 S1-2: PHONO ON - OFF
 S1-3: TUNER ON - OFF
 S1-4: AUX 1 ON - OFF
 S1-5: AUX 2 ON - OFF
- TAPE MODE ASSEMBLY**
 S2: TAPE MONITOR TAPE1 - SOURCE - TAPE 2
 S3: TAPE COPY 1 = 2 - OFF - 2 = 1
 S7: MODE REV - STEREO - MONO
- MUTING ASSEMBLY**
 S6: MUTING ON - OFF
- EQUALIZER ASSEMBLY**
 S1: MC-MM SELECT MC 3Ω - MC 40Ω - MM
- SPEAKER SELECT ASSEMBLY**
 S1: SP SELECT A+B - B - A - OFF
- TAPE INDICATOR ASSEMBLY**
 S4: SUBSONIC ON - OFF
 S5: LINE STRAIGHT ON - OFF
- OTHER**
 S1: POWER ON - OFF
- THE UNDERLINED INDICATES THE SWITCH POSITION

NOTE:
 The indicated semiconductors are representative ones only.
 Other alternative semiconductors may be used and are listed in the parts list.

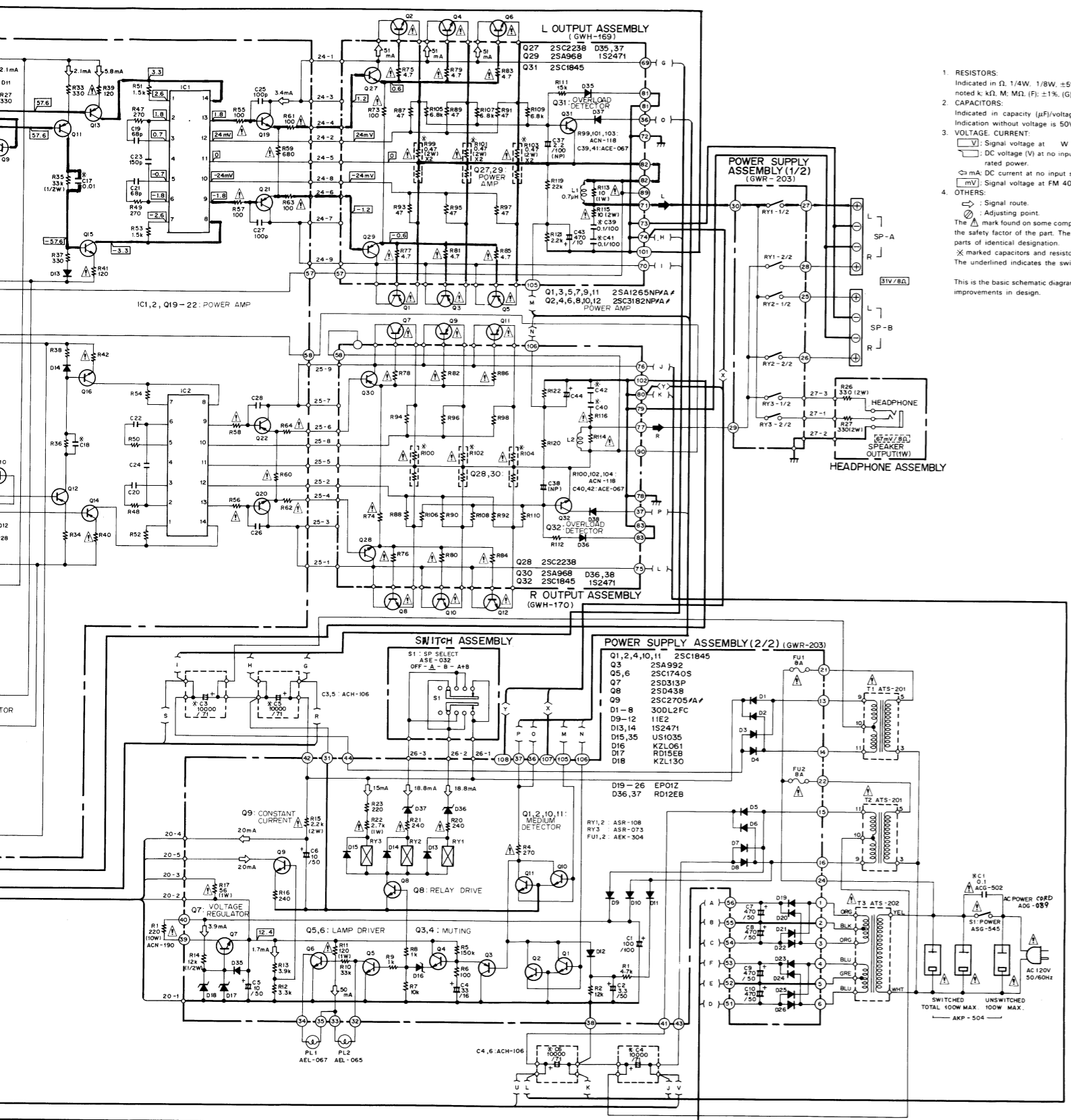

External Appearance of Transistors and ICs

M5220P

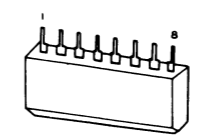

PA0016

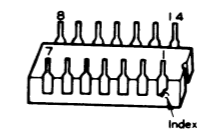

2SA1145 (A)
2SC2705

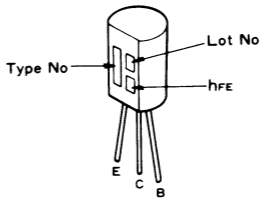

2SC1845
2SA992

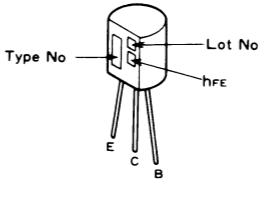

2SA968
3SC2238
2SD313P

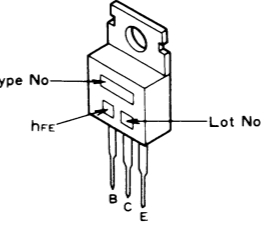

2SA898
2SC1903

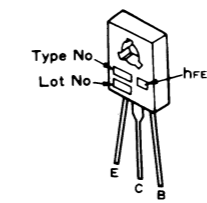

2SC1740S

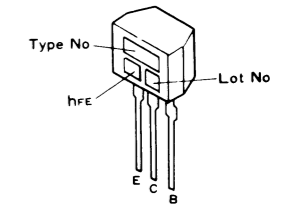

2SD438
2SB560

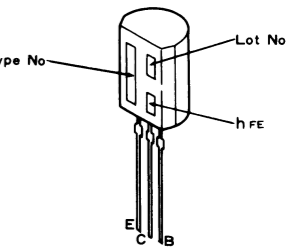

2SK129A

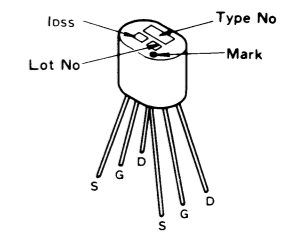

2SK194

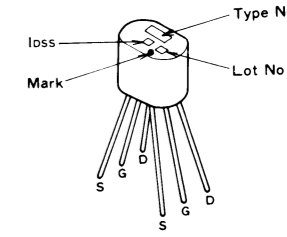

2SK246

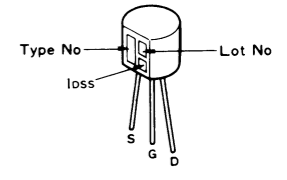

2SA1265NP(A)
2SC3182NP(A)

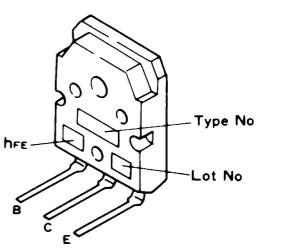

- RESISTORS:
Indicated in Ω, 1/4W, 1/8W, ±5% tolerance unless otherwise noted; k: kΩ, M: MΩ, (F): ±1%, (G): ±2%, (K): ±10%, (M): ±20% tolerance
 - CAPACITORS:
Indicated in capacity (pF)/voltage (V) unless otherwise noted; p: pF. Indication without voltage is 50V except electrolytic capacitor.
 - VOLTAGE, CURRENT:
V: Signal voltage at W + W, 8Ω output (1 kHz)
V: DC voltage (V) at no input signal Value in () is DC voltage at rated power.
mA: DC current at no input signal
mV: Signal voltage at FM 400 Hz ± 75 kHz DEV.
 - OTHERS:
S: Signal route.
A: Adjusting point.
The mark found on some component parts indicates the importance of the safety factor of the part. Therefore, when replacing, be sure to use parts of identical designation.
X: marked capacitors and resistors have parts numbers.
The underlined indicates the switch position.
- This is the basic schematic diagram, but the actual circuit may vary due to improvements in design.

A

B

C

D

9. ELECTRICAL PARTS LIST

NOTES:

- When ordering resistors, first convert resistance values into code form as shown in the following examples.

Ex. 1 When there are 2 effective digits (any digit apart from 0), such as 560 ohm and 47k ohm (tolerance is shown by J = 5%, and K = 10%).

560Ω	56 × 10 ¹	561	RD¼PS	561J
47kΩ	47 × 10 ³	473	RD¼PS	473J
0.5Ω	0R5		RN2H	0R5K
1Ω	010		RS1P	010K

Ex. 2 When there are 3 effective digits (such as in high precision metal film resistors).

5.62kΩ	562 × 10 ¹	5621	RN¼SR	5621F
--------	-----------------------	------	-------	-------

- The **△** mark found on some component parts indicates the importance of the safety factor of the part. Therefore, when replacing, be sure to use parts of identical designation.
- For your Parts Stock Control, the fast moving items are indicated with the marks **★★** and **★**.
★★ GENERALLY MOVES FASTER THAN ★.
 This classification shall be adjusted by each distributor because it depends on model number, temperature, humidity, etc.

Miscellaneous Parts

P.C. BOARD ASSEMBLIES

Mark	Symbol & Description	Part No.
	Voltage amplification assembly	GWH-168
	Output (L) assembly	GWH-169
	Output (R) assembly	GWH-170
	Function assembly	GWS-519
	Tape mode assembly	GWS-520
	Tape display assembly	GWS-521
	Muting assembly	GWS-522
	Equalizer assembly	GWF-160
	Pin jack assembly	GWY-106
	Tone assembly	GWG-186
	Volume assembly	GWY-110
	Power supply assembly	GWR-203
	Switch assembly	
	Headphone assembly	

OTHERS

Mark	Symbol & Description	Part No.
△★★	Q1, Q3, Q5, Q7, Q9, Q11	2SA1265NP(A)-O/R*
△★★	Q2, Q4, Q6, Q8, Q10, Q12	2SC3182NP(A)-O/R*
△	R1 (220 Ω/10W)	ACN-190
△	C1 (0.01/AC400V)	ACG-502
	C3-C6 (10000/71V)	ACH-106
	*hfe of Q1-Q12 should have the same value.	
△★	T1, T2 Power transformer	ATS-201
△★	T3 Power transformer	ATS-202
	Terminal (SPEAKER)	AKE-110
△★★	S1 Push switch (POWER)	ASG-545
★★	S2 Remote slide rotary switch	ASX-206
△★★	FU1, FU2 Fuse (8A)	AEK-304
★★	PL2 Pilot lamp	AEL-065
★★	PL1 Pilot lamp	AEL-067
	Screw	PBZ30P060FMC
△	AC socket	AKP-504
★★	T4 MC Transformer	ATT-987
△	AC Power cord	ADG-089

Power Supply Assembly (GWR-203)

SEMICONDUCTORS

Mark	Symbol & Description	Part No.
★★	Q1, Q2, Q4, Q10, Q11	2SC1845
★★	Q3	2SA992
★★	Q5, Q6	2SC1740S
★★	Q7	2SD313P
★★	Q8	2SD438
★★	Q9	2SC2705
★	D1-D8	30DL2FC
★	D9-D12	11E2
★	D13, D14	1S2471
★	D15, D35	US1035
★	D16	KZL061
★	D17	RD15EB
★	D18	KZL130
★	D19-D26	EP01Z
★	D36, D37	RD12EB

CAPACITORS

Mark	Symbol & Description	Part No.
	C5, C6	CEA 100M 50L
	C1	CEA 101M 100L
	C2	CEA 3R3M 50L
	C4	CEA 330M 16L
	C7-C10	CEYA 471M 50

RESISTORS

Note: When ordering resistors, convert the resistance value into code form, and then rewrite the part no. as before.

Mark	Symbol & Description	Part No.
	R1, R2, R5-R10, R12, R13, R16, R23	RD1/4PM□□□J
⚠	R4, R20, R21	RFA1/4PS□□□J
⚠	R11, R17, R22	RS1LMF□□□J
⚠	R15	RS2LMF 222J
	R14	RD1/2PM 123J

RELAIIES

Mark	Symbol & Description	Part No.
★	RY1, RY2 Relay	ASR-108
★	RY3 Relay	ASR-073

Switch Assembly

Mark	Symbol & Description	Part No.
★★	S1 Slide rotary switch (SPEAKER)	ASE-032

Headphone Assembly

Mark	Symbol & Description	Part No.
⚠	R26, R27 Jack (PHONES)	RS2LMF 331J AKN-045

Function Assembly (GWS-519)

SEMICONDUCTORS

Mark	Symbol & Description	Part No.
★	D1-D5 (LED)	AEL-388

SWITCH

Mark	Symbol & Description	Part No.
★★	S1 Push switch (FUNCTION)	ASG-821

Tape Mode Assembly (GWS-520)

SWITCHES

Mark	Symbol & Description	Part No.
★★	S2 Slide rotary switch (TAPE MONITOR)	ASE-031
★★	S3 Rotary switch (TAPE COPY)	ASD-128
★★	S7 Slide rotary switch (MODE)	ASE-023

RESISTORS

Note: When ordering resistors, convert the resistance value into code form, and then rewrite the part no. as before.

Mark	Symbol & Description	Part No.
	R7-R12	RD1/4PM□□□J

Tape Display Assembly (GWS-521)

SEMICONDUCTORS

Mark	Symbol & Description	Part No.
★	D6, D7 (LED)	AEL-383
★	D8, D9 (LED)	AEL-388
★	D10	US1035

SWITCHES, RELAY

Mark	Symbol & Description	Part No.
★	RY1 Relay	ASR-077
★★	S4 Push switch (SUBSONIC)	SEAV2S
★★	S5 Push switch (LINE STRAIGHT)	SEAV4S

CAPACITORS

Mark	Symbol & Description	Part No.
	C1, C2 (0.22/100V)	ACE-075

RESISTORS

Note: When ordering resistors, convert the resistance value into code form, and then rewrite the part no. as before.

Mark	Symbol & Description	Part No.
	R1, R2, R13-R16	RD1/4PM□□□J

OTHERS

Mark	Symbol & Description	Part No.
★★	PL1 Pilot lamp	AEL-172

Muting Assembly (GWS-522)

SEMICONDUCTOR

Mark	Symbol & Description	Part No.
★	D11	AEL-383

SWITCH

Mark	Symbol & Description	Part No.
★★	S6 Push switch (MUTING)	SEAV4S

CAPACITORS

Mark	Symbol & Description	Part No.
	C3, C4	CQSXA 121J 160

RESISTORS

Note: When ordering resistors, convert the resistance value into code form, and then rewrite the part no. as before.

Mark	Symbol & Description	Part No.
	R3-R6	RD1/4PM □□□J

Tone Assembly (GWG-186)

SEMICONDUCTORS

Mark	Symbol & Description	Part No.
★★	IC1, IC2	M5220P
★	D1-D4	RD22EB
★★	Q1, Q2	2SC1845

CAPACITORS

Mark	Symbol & Description	Part No.
	C3, C4, C7-C10, C17, C18	CEA 100M 50L
	C13, C14	CEA 1R5M 50L
	C5, C6	CQMA 104J 50
	C11, C12	CQMA 562J 50
	C15, C16	CCDSL 101J 50

RESISTORS

Note: When ordering resistors, convert the resistance value into code form, and then rewrite the part no. as before.

Mark	Symbol & Description	Part No.
★	VR1, VR2 (50k-X2)	ACT-189
	R7, R8	RD1/2PS 822J
△	R13-R16	RS2LMF 102J
	R1-R6, R9-R12, R19-R24	RD1/4PM □□□J

Volume Assembly (GWY-110)

CAPACITORS

Mark	Symbol & Description	Part No.
	C19, C20	CQSXA 102J 160

RESISTORS

Mark	Symbol & Description	Part No.
★	VR3 Variable resistor (250k)	ACT-179
★	VR4 Variable resistor (68k)	ACT-132
	R25-R27	RDH1/8P □□□J

Equalizer Assembly (GWF-160)

SEMICONDUCTORS

Mark	Symbol & Description	Part No.
★★	Q1, Q2	2SK194
★★	Q3-Q6, Q9, Q10, Q105, Q106, Q109, Q110	2SC1845
★★	Q7, Q8, Q11, Q12, Q107, Q108, Q111, Q112	2SA992
★★	Q13, Q14	2SC1903-B/V *
★★	Q15, Q16	2SA898-B/V *
	*hfe of Q13-Q16 should have the same value.	
★★	Q101, Q102	2SB560
★★	Q103, Q104	2SD438
★★	Q113-Q116	2SK246
★	D7-D10	EP01Z
★	D1, D2	11E2
★	D3-D6 (LED)	AEL-398
★	D11, D12	RD3.9EB
★	D101-D104	US1035
★	D105, D106	RD22EB

SWITCH

Mark	Symbol & Description	Part No.
★★	S1 Remote slide switch (MC-MM)	ASX-199

CAPACITORS

Mark	Symbol & Description	Part No.
	C25, C26 (0.01/100V)	ACE-066
	C17, C18 (0.1/100V)	ACE-067
	C5, C6, C11, C12 (1200p/100V)	ACE-086
	C9, C10 (0.033/100V)	ACE-094
	C7, C8	ACE-095
	C23, C24 (22/50V)	ACH-456
	C13, C14	CEYA 102M 25
	C101-C104	CEYA 221M 50
	C113, C114	CEYA 331M 50
	C3, C4, C19-C22	CEA 101J 500
	C105-C108	CEXA 2R2M 50
	C1, C2	CMA 221J 500
	C15, C16, C115-C118	CMA 470J 500
	C109-C112	CQSXA 471J 160

RESISTORS

Note: When ordering resistors, convert the resistance value into code form, and then rewrite the part no. as before.

Mark	Symbol & Description	Part No.
★	VR1, VR2 Semi-fixed resistor	ACP-102
	R21-R28	RDH1/4 P □□□J
	R1-R16, R29, R30, R43-R54, R101-R110	RD1/4P M □□□J

Mark	Symbol & Description	Part No.
⚠	R35-R42, R111-R114	RFA1/4PS□□□J
⚠	R115-R118	RS2LMF 4R7J
	R31, R32	RH1/4P 470J
	R17-R20, R33, R34	RD1/2PM□□□J

OTHERS

Mark	Symbol & Description	Part No.
	Terminal 2P (PHONO)	AKB-114
	Terminal 4P (CD,TU, VIDEO SOUND/AKB-115 AUX1, AUX2)	AKB-115

Pin Jack Assembly (GWY-106)

Mark	Symbol & Description	Part No.
	R201-R204	RD1/4PM 101J
	Terminal 4P (TAPE1, TAPE2)	AKB-116

Voltage Amplification Assembly (GWH-168)

SEMICONDUCTORS

Mark	Symbol & Description	Part No.
★★	IC1, IC2	PA0016
★★	Q13, Q14, Q21, Q22	2SA1145-O/Y*
★★	Q11, Q12	2SA992
★★	Q25, Q26	2SB560
★★	Q3-Q10	2SC1845
★★	Q15, Q16, Q19, Q20	2SC2705-O/Y*
	*hfe of Q13-Q16, Q19-Q22 should have the same value.	
★★	Q23, Q24	2SD438
★★	Q1, Q2	2SK129A
★	D1-D4, D27-D34	RD30EB
★	D5-D8	US1035
★	D9-D14	11E2
★	D39, D40	10YD45AFD

CAPACITORS

Mark	Symbol & Description	Part No.
	C17, C18 (0.01/100V)	ACE-066
	C33-D36 (47/63V)	ACH-452
	C29-C32 (220/63V)	ACH-454
	C9, C10 (470/50)	ACH-455
	C3-C4	CEYA 331M 50
	C25-C28	CMA 101J 500
	C11-C14	CMA 150J 500
	C19-C22	CMA 680J 500
	C7, C8	CQSXA 102J 160
	C23, C24	CQSXA151J 160

Mark	Symbol & Description	Part No.
	C1, C2	CQSXA 221J 160
	C15, C16	CQSXA 561J 160

RESISTORS

Note : When ordering resistors, convert the resistance value into code form, and then rewrite the part no. as before.

Mark	Symbol & Description	Part No.
	R21-R24	RDH1/4P□□□J
	R5, R6, R35, R36	RD1/2PM□□□J
⚠	R59, R60	RD1/4PMFL 681J
	R7-R16, R25-R34, R37, R38, R47-R54	RD1/4PM□□□J
⚠	R39-R42, R55-R58, R61-R68	RFA1/4PS□□□J
⚠	R69-R72	RS1LMF 272J
	R1-R4	RDH1/8P□□□J

Output (L) Assembly (GWH-169)

SEMICONDUCTORS

Mark	Symbol & Description	Part No.
★★	Q29	2SA968-O/Y*
★★	Q31	2SC1845
★★	Q27	2SC2238-O/Y*
	*hfe of Q27, Q29 should have the same value.	
★	D35, D37	1S2471

CAPACITORS

Mark	Symbol & Description	Part No.
	C39, C41 (0.1/100V)	ACE-067
	C37	CEANP 2R2M100
	C43	CEA 471M 10L

RESISTORS

Note : When ordering resistors, convert the resistance value into code form, and then rewrite the part no. as before.

Mark	Symbol & Description	Part No.
⚠	R99, R101, R103 (0.47Ω2W)	ACN-11B
⚠	R87, R89, R91, R93, R95, R97, R105, R107, R109, R121, R111, R119	RD1/4PMF□□□J
⚠	R75, R77, R79, R81, R85	RD1/4PM□□□J
⚠	R113	RFA1/4PS 4R7J
		RSILMF 100J
⚠	R115	RS2LMF 100J
⚠	R73	RFA1/4PS 101J

COIL

Mark	Symbol & Description	Part No.
	L1 AF choke coil (0.7μH)	ATH-054

OTHERS

Mark	Symbol & Description	Part No.
	Screw	PBZ30P060FMC

Output (R) Assembly (GWH-169)

SEMICONDUCTORS

Mark	Symbol & Description	Part No.
★★	Q30	2SA968-O/Y*
★★	Q32	2SC1845
★★	Q28	2SC2238-O/Y*
	*hfe of Q28, Q30 should have the same value.	
★	D36, D38	1S2471

CAPACITORS

Mark	Symbol & Description	Part No.
	C40, C42 (0.1/100V)	ACE-067
	C38	CEANP 2R2M 100
	C44	CEA 471M 10L

10. PACKING

Mark	No.	Part No.	Description
	1.	ARB-659	Operating instructions
	2.	AHE-516	Packing case
	3.	AHA-328	Side pad L
	4.	AHA-329	Side pad R
	5.	AHB-149	Protector A
	6.	AHB-150	Protector B
	7.	AMS-057	Side board assembly

RESISTORS

Note: When ordering resistors, convert the resistance value into code form, and then rewrite the part no. as before.

Mark	Symbol & Description	Part No.
⚠	R100, R102, R104 (0.47 Ω2W)	ACN-118
⚠	R88, R90, R92, R94, R96, R98 R106, R108, R110, R122, R112, R120	RD1/4PMF □□□ J
⚠	R74, R76, R78, R80, R82, R84, R86	PD1/4PM □□□ J
⚠	R114	RFA1/4PS □□□ J
⚠	R116	RS1LMF 100J
⚠	R116	RS2LMF 100J

COIL

Mark	Symbol & Description	Part No.
	L2 AF choke coil (0.7μH)	ATH-054

OTHERS

Mark	Symbol & Description	Part No.
	Screw	PBZ30P060FMC

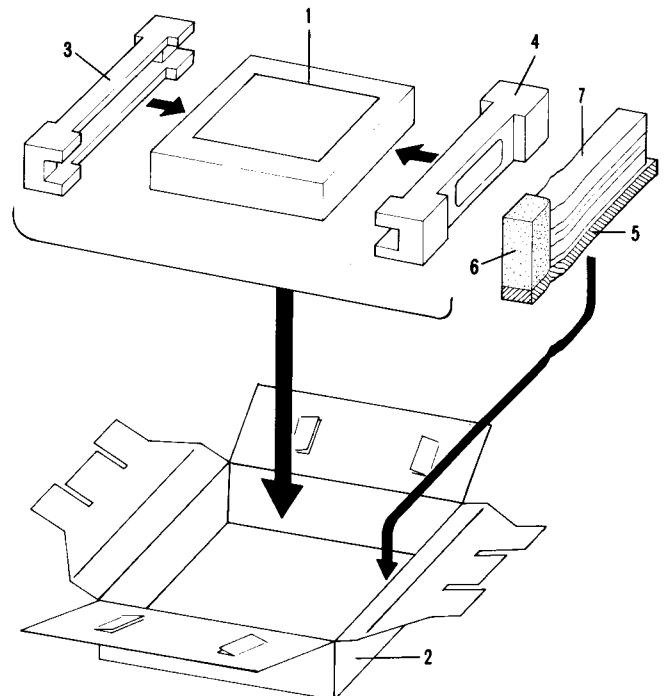

11. SAFETY INFORMATION

1. SAFETY PRECAUTIONS

The following check should be performed for the continued protection of the customer and service technician.

LEAKAGE CURRENT CHECK

Measure leakage current to a known earth ground (water pipe, conduit, etc.) by connecting a leakage current tester such as Simpson Model 229-2 or equivalent between the earth ground and all exposed metal parts of the appliance (input/output terminals, screwheads, metal overlays, control shaft, etc.). Plug the AC line cord of the appliance directly into a 120V AC 60Hz outlet and turn the AC power switch on. Any current measured must not exceed 0.5mA.

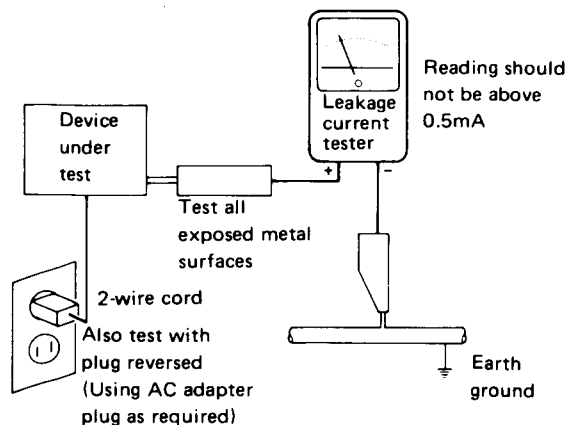

AC Leakage Test

ANY MEASUREMENTS NOT WITHIN THE LIMITS OUTLINED ABOVE ARE INDICATIVE OF A POTENTIAL SHOCK HAZARD AND MUST BE CORRECTED BEFORE RETURNING THE APPLIANCE TO THE CUSTOMER.

2. PRODUCT SAFETY NOTICE

Many electrical and mechanical parts in the appliance have special safety related characteristics. These are often not evident from visual inspection nor the protection afforded by them necessarily can be obtained by using replacement components rated for voltage, wattage, etc. Replacement parts which have these special safety characteristics are identified in this Service Manual.

Electrical components having such features are identified by marking with a ⚠ on the schematics and on the parts list in this Service Manual.

The use of a substitute replacement component which does not have the same safety characteristics as the PIONEER recommended replacement one, shown in the parts list in this Service Manual, may create shock, fire, or other hazards.

Product Safety is continuously under review and new instructions are issued from time to time. For the latest information, always consult the current PIONEER Service Manual. A subscription to, or additional copies of, PIONEER Service Manual may be obtained at a nominal charge from PIONEER.