

Service Manual

PIONEER
The future of sound and vision.

Original

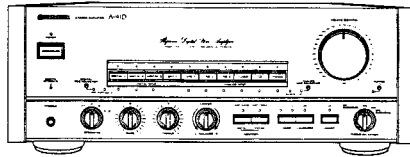

**ORDER NO.
ARP1464**

STEREO AMPLIFIER

A-91D

MODEL A-91D COMES IN FOUR VERSIONS DISTINGUISHED AS FOLLOWS:

Type	Power requirement	Export destination
KU/CA	AC120V only	U.S.A and Canada
HB	AC220V,240V(Switchable)*	United Kingdom
HEZ	AC220V,240V(Switchable)*	West Germany
SD/G	AC110V,120V-127V,220V,240V(Switchable)	U.S.Military

*Change the primary fuse of the power supply assembly and the Primary wiring.

- This service manual is applicable to the KU/CA,HB,HEZ and SD/G types.
- As to the HB,HEZ and SD/G types,please refer to pages P69-P70
- Ce manuel pour le service comprend les explications en français de réglage.(P65-P66)
- Este manual de servicio trata del método ajuste escrito en español.(P67-P68)

CONTENTS

1. SAFETY INFORMATION	2	8. IMAGE DIAGRAM	41
2. SPECIFICATIONS	3	9. ELECTRICAL PARTS LIST	45
3. PANEL FACILITIES	4	10. CIRCUIT DESCRIPTIONS	52
4. EXPLODED VIEWS AND PARTS LIST...	8	11. IC INFORMATION	57
5. PACKING	8	12. ADJUSTMENT	63
6. SCHEMATIC DIAGRAM	13	RÉGLAGE	
7. P.C.BOARDS CONNECTION		AJUSTE	
DIAGRAM	29	13. FOR HB, HEZ and SD/G TYPES	69

PIONEER ELECTRONIC CORPORATION 4-1, Meguro 1-Chome, Meguro-ku, Tokyo 153, Japan
PIONEER ELECTRONICS SERVICE INC. P.O. Box 1760, Long Beach, California 90801 U.S.A.
PIONEER ELECTRONICS OF CANADA, INC. 505 Cochrane Drive, Markham, Ontario L3R 8E3 Canada
PIONEER ELECTRONIC [EUROPE] N.V. Keetberglaan 1, 2740 Beveren, Belgium
PIONEER ELECTRONICS AUSTRALIA PTY. LTD. 178-184 Boundary Road, Braeside, Victoria 3195, Australia TEL: [03] 580-9911

YÁ © AUG 1987 Printed in Japan

1. SAFETY INFORMATION

1. SAFETY PRECAUTIONS

The following check should be performed for the continued protection of the customer and service technician.

LEAKAGE CURRENT CHECK

Measure leakage current to a known earth ground (water pipe, conduit, etc.) by connecting a leakage current tester such as Simpson Model 229-2 or equivalent between the earth ground and all exposed metal parts of the appliance (input/output terminals, screwheads, metal overlays, control shaft, etc.). Plug the AC line cord of the appliance directly into a 120V AC 60Hz outlet and turn the AC power switch on. Any current measured must not exceed 0.5mA.

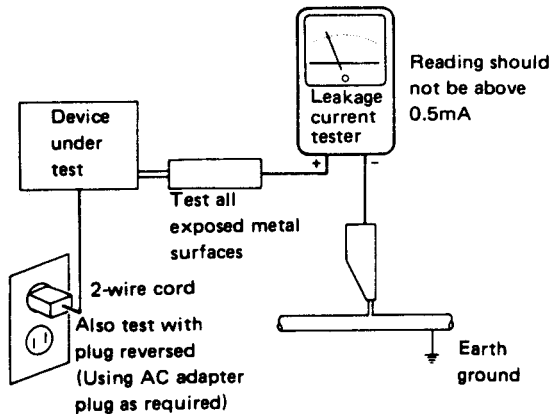

AC Leakage Test

ANY MEASUREMENTS NOT WITHIN THE LIMITS OUTLINED ABOVE ARE INDICATIVE OF A POTENTIAL SHOCK HAZARD AND MUST BE CORRECTED BEFORE RETURNING THE APPLIANCE TO THE CUSTOMER.

2. PRODUCT SAFETY NOTICE

Many electrical and mechanical parts in the appliance have special safety related characteristics. These are often not evident from visual inspection nor the protection afforded by them necessarily can be obtained by using replacement components rated for voltage, wattage, etc. Replacement parts which have these special safety characteristics are identified in this Service Manual.

Electrical components having such features are identified by marking with a Δ on the schematics and on the parts list in this Service Manual.

The use of a substitute replacement component which does not have the same safety characteristics as the PIONEER recommended replacement one, shown in the parts list in this Service Manual, may create shock, fire, or other hazards.

Product Safety is continuously under review and new instructions are issued from time to time. For the latest information, always consult the current PIONEER Service Manual. A subscription to, or additional copies of, PIONEER Service Manual may be obtained at a nominal charge from PIONEER.

ADVARSEL!

Lithiumbatteri. Eksplosionsfare. Udskiftning må kun foretages af en sagkyndig, og som beskrevet i servicemanualen.

WARNING!

Lithium batteries. Danger of explosion. Replacement must be done by qualified personnel and only by following the instructions given in the service manual.

Denne advarsel er angivet på produktet eller i brugsvejledningen. Ved udskiftning af lithium batterierne følges nedenstående anvisning. Batterierne må kun udskiftes med batterier af samme type og mærke.

This warning is stated on the product or in the operating instructions. When replacing the lithium batteries, follow the note below. The batteries must be replaced only by batteries of the same type and manufacture.

Exterior

A

B

C

D

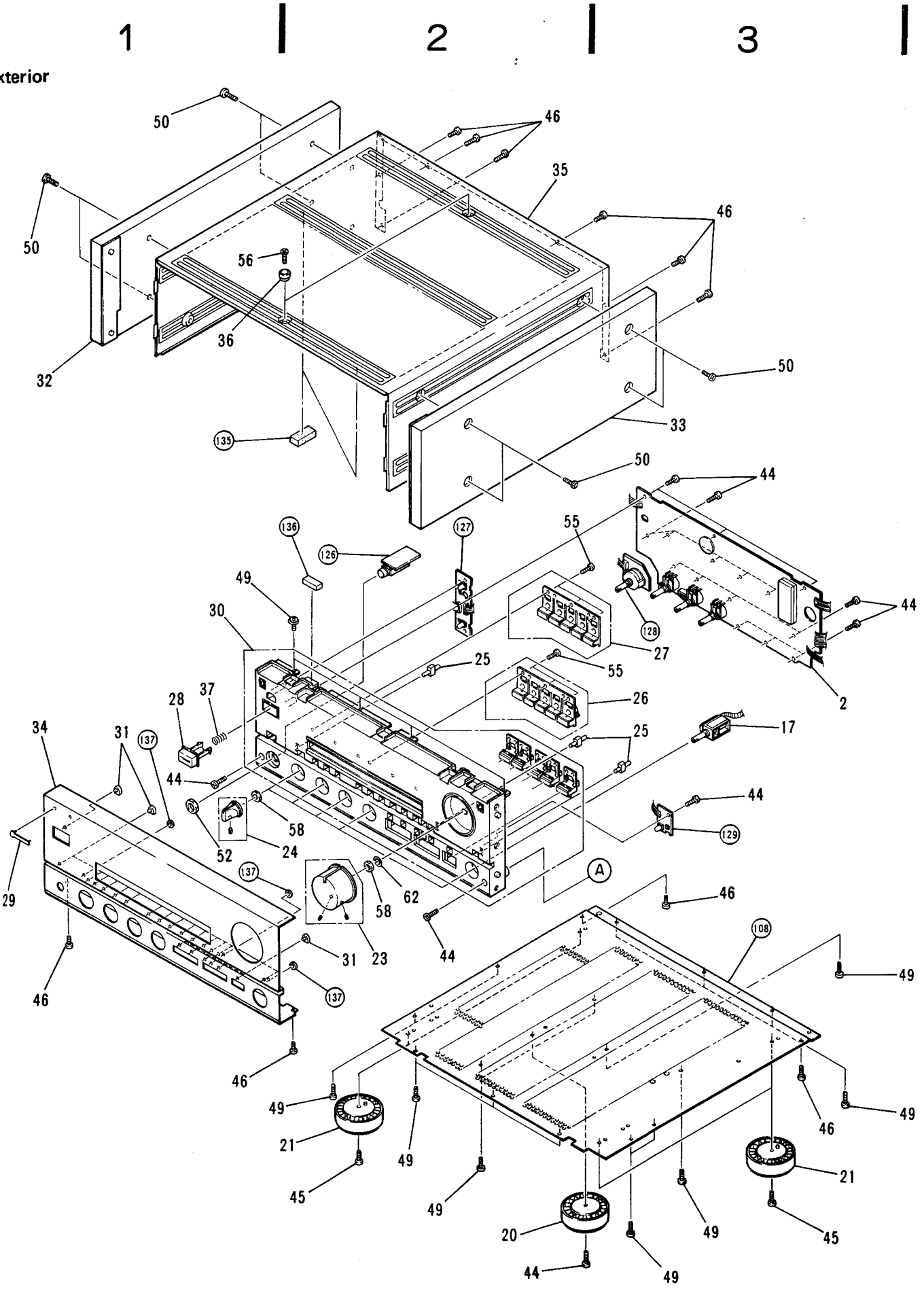

Caution : Different from the standard model, this condenser is directly connected. Be careful not to get an electric shock or to cause a shortcircuit.

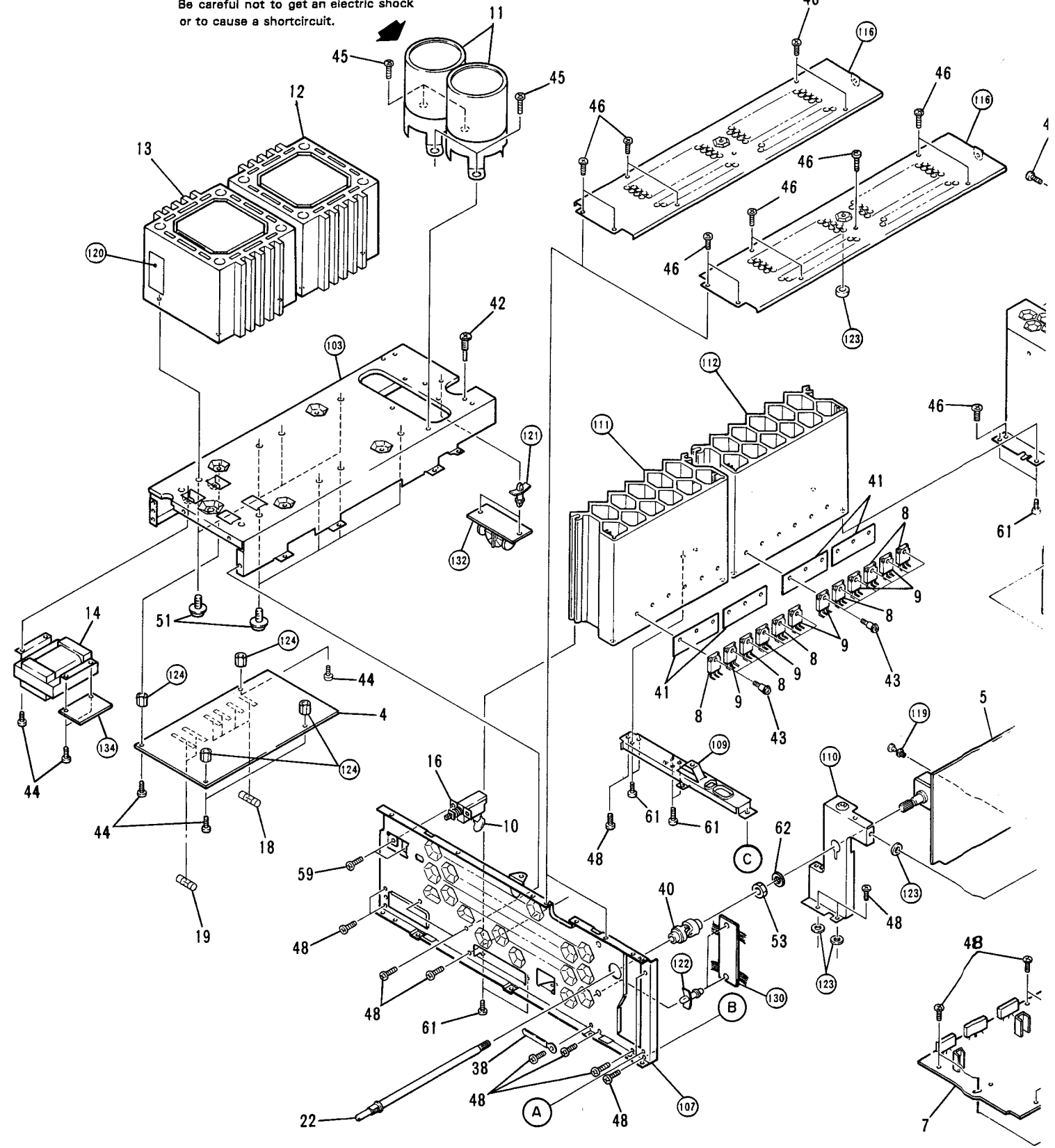

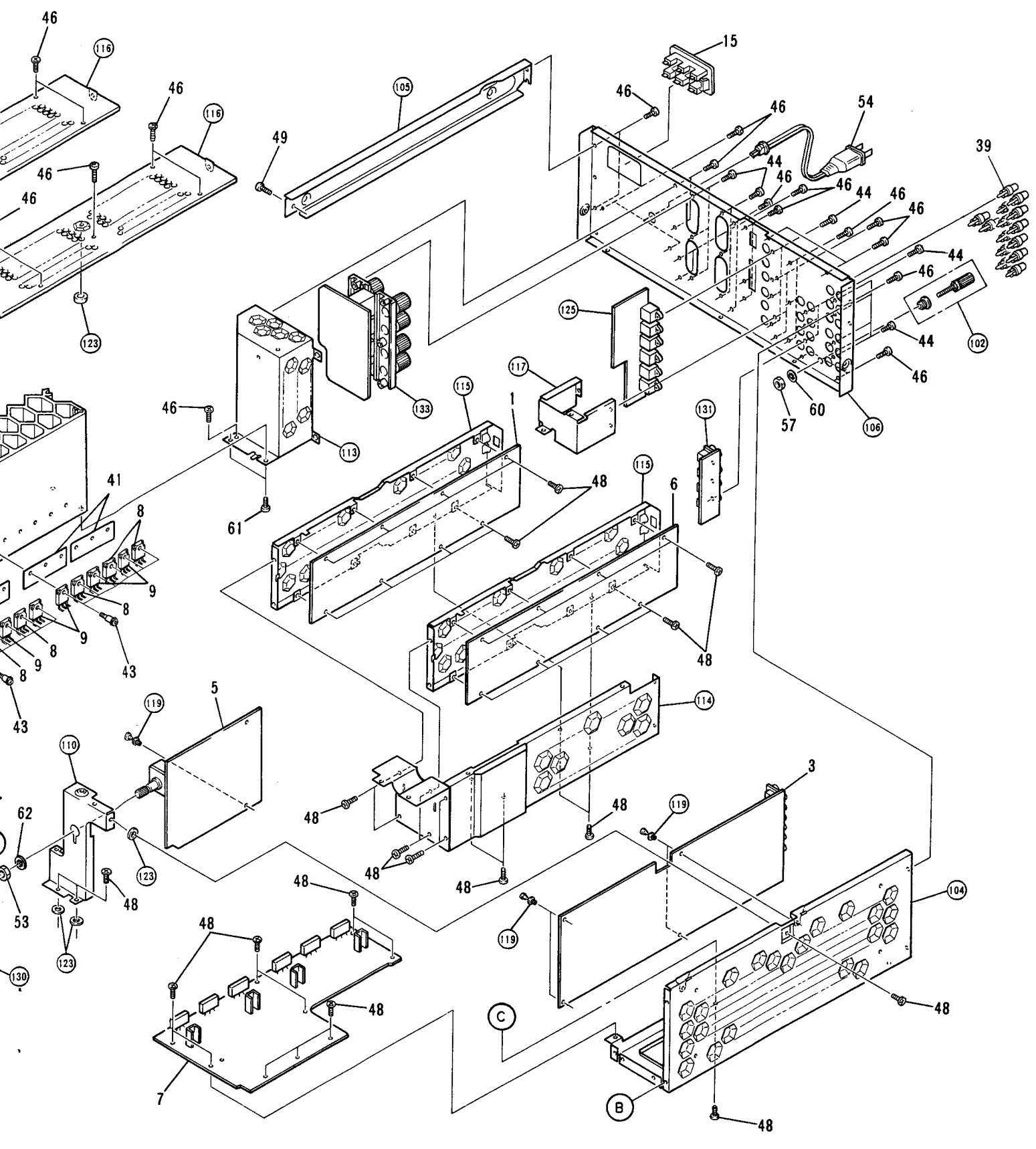

External Appearance of Transistors and ICs

A
B
C
D

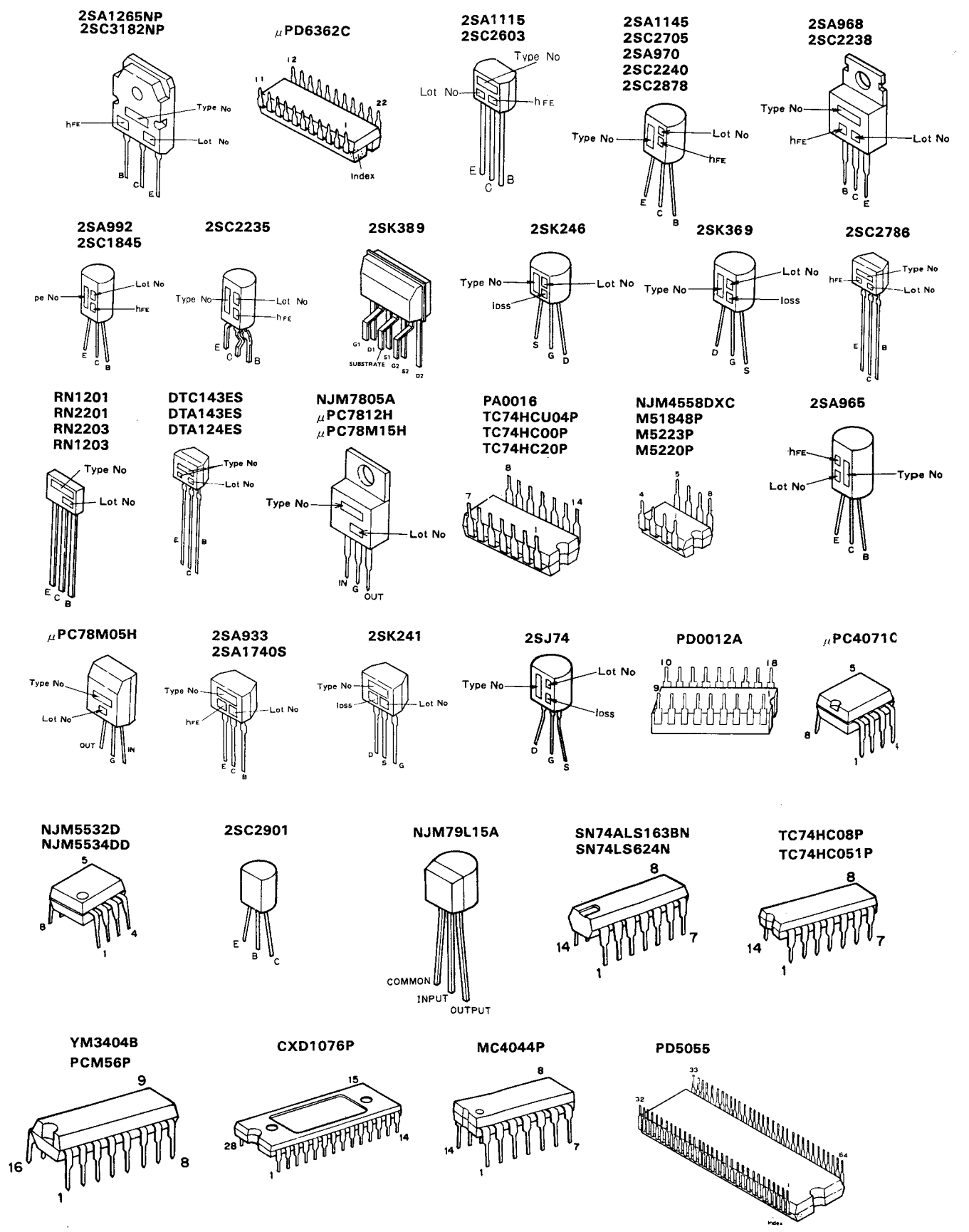

4. EXPLODED VIEWS AND PARTS LIST

NOTES:

- Parts without part number cannot be supplied.
- The \triangle mark found on some component parts indicates the importance of the safety factor of the part. Therefore, when replacing, be sure to use parts of identical designation.
- For your parts Stock Control, the fast moving items are indicated with the marks $\star\star$ and \star .
 $\star\star$ **GENERALLY MOVES FASTER THAN \star**
 This classification shall be adjusted by each distributor because it depends on model number, temperature, humidity, etc.
- Parts marked by "●" are not always kept in stock. Their delivery time may be longer than usual or they may be unavailable.

Parts List of Exterior

Mark	No.	Parts No.	Description	Mark	No.	Parts No.	Description
	1	AWZ1507	DAC 2 Assembly		28	AAD1197	Knob(POWER)
	2	AWZ1517	μ COM/TONE Assembly		29	AAM1001	Name plate
	3	AWZ1511	INPUT/EQ Assembly		30	AMB1225	Panel base Assembly
	4	AWZ1512	PWS Assembly		31	AMR1160	LED Lens
	5	AWZ1513	VR/REC Assembly		32	AMS1017	Side board L
	6	AWZ1506	DAC/LPF Assembly		33	AMS1018	Side board R
	7	AWZ1514	POWER AMP Assembly		34	ANB1134	Front panel
$\triangle\star\star$	8	2SA1265NP	Q1-Q6 Transistor		35	ANE1085	Bonnet case
$\triangle\star\star$	9	2SC3182NP	Q7-Q12 Transistor		36	ABE1009	Washer
\triangle	10	ACG1003	C1 Ceramic capacitor (0.01/125V)		37	ABH1033	Coil spring A
					38
\triangle	11	ACH1046	C2,C3 Electric capacitor		39	AKM-050	Short pin plug 40AMR1178Joint
$\triangle\star$	12	ATS1097	T1 Power transformer (120V)		41	AMR1180	Mica sheet
$\triangle\star$	13	ATS1098	T2 Power transformer (120V)		42	ABA-176	Screw
$\triangle\star$	14	ATT1047	T3 Power transformer (120V)		43	ABA-297	Screw
\triangle	15	AKP-515	AC socket (OUTLET 3P)		44	ABA-298	Screw (3 x 8)
					45	ABA1004	Screw (4 x 8)
$\triangle\star\star$	16	ASG-553	S1 Push switch(Power)		46	ABA1006	Screw (3 x 8)
$\star\star$	17	ASU1004	S2 Remote slide Rotary switch		47	ABA1007	Screw (3 x 10)
					48	ABA1009	Screw (3 x 6)
$\triangle\star\star$	18	AEK-119	FU3-FU6 Fuse (1A/125V)		49	ABA1011	Screw (3 x 6)
$\triangle\star\star$	19	AEK-309	FU1,FU2 Fuse (6.3A/125V)		50	ABA1032	Decorative screw
	20	AMR1158	Leg Assembly		51	ABA1034	Screw (4 x 12)
	21	AMR1159	Leg Assembly		52	ABN-065	Nut
	22	ANL1009	Long shaft Assembly		53	ABN-092	Nut(M9)
	23	AAB1036	Rotary Knob L (VOLUME)	\triangle	54	ADG-089	AC power cord
	24	AAB1040	Rotary Knob S (SP selector /BASS / TREBLE / BALANCE / PHONO selector)		55	BBZ30P100FZK	Screw (3 x 10)
	25	AAD1016	Tact Knob B (MUTING / ANALOG REC selector / DIGITAL REC selector)		56	BBZ40PO80FZK	Screw (4 x 8)
	26	AAD1193	Function Knob Assembly (PHONO / CD / TUNER / LINE2 / LINE1)		57	NK70FUC	Nut
	27	AAD1194	Function Knob Assembly (TAPE1 / DAT / DIGITAL3 / DIGITAL2 / DIGITAL1)		58	NK90FUC	Nut
					59	VMZ30PO60FCU	Screw (3 x 6)
					60	WG70FUC	Washer
					61	ARA1050	Screw(3x10)
					62	AEB1001	Washer

Mark	No.	Parts No.	Description	Mark	No.	Parts No.	Description
	101			121		PCB suport
	102		Terminal (EARTH)		122		PCB Holder
	103		Trans frame		123		Spacer
	104		Right frame		124		PCB Holder
	105		Left frame		125		DAC 3 Assembly
	106		Rear panel		126		HP Assembly
	107		Panel stay		127		IND Assembly
	108		Bottom plate		128		SP SW Assembly
	109		Heat sink holder		129		MUTING SW Assembly
	110		Volume holder		130		JUNPER CONNECT Assembly
	111		Heat sink				
	112		Heat sink		131		PIN JACK Assembly
	113		Sield case		132		LINE FILTER Assembly
	114		Sield case		133		SP TERMINAL Assembly
	115		Sield plate		134		JUMPER CONNECT Assembly
	116		Sield plate		135		Cushion rubber
	117		Sield plate				
	118			136		Cushion rubber C
	119		Pin gromet		137		Cushion
	120		Barrier				

5. PACKING

Parts List of Packing

Mark	No.	Parts No.	Description
	1	AHA1087	Front Pad
	2	AHA1090	Rear Pad
	3	AHD1261	Paking case
	4	ARB1076	Operating instructions(English)

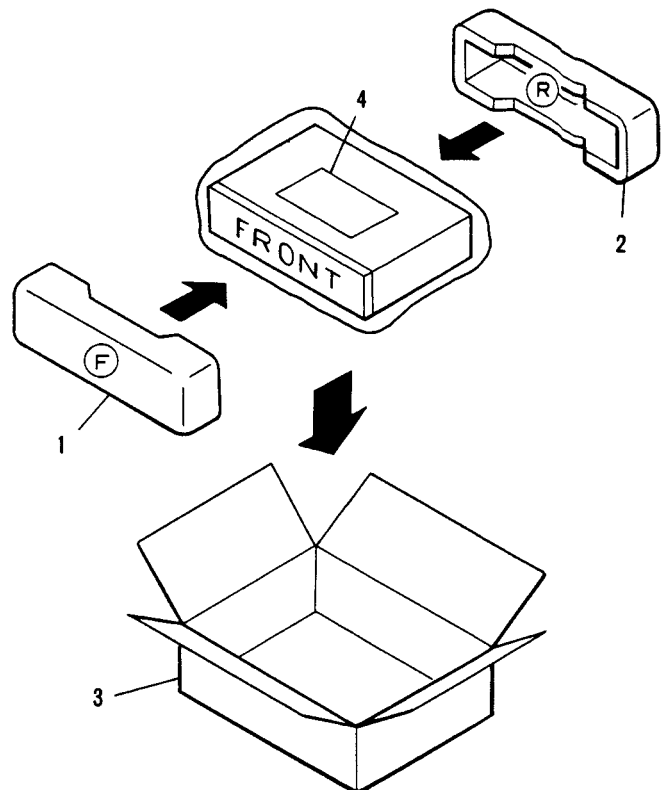

A

B

C

D

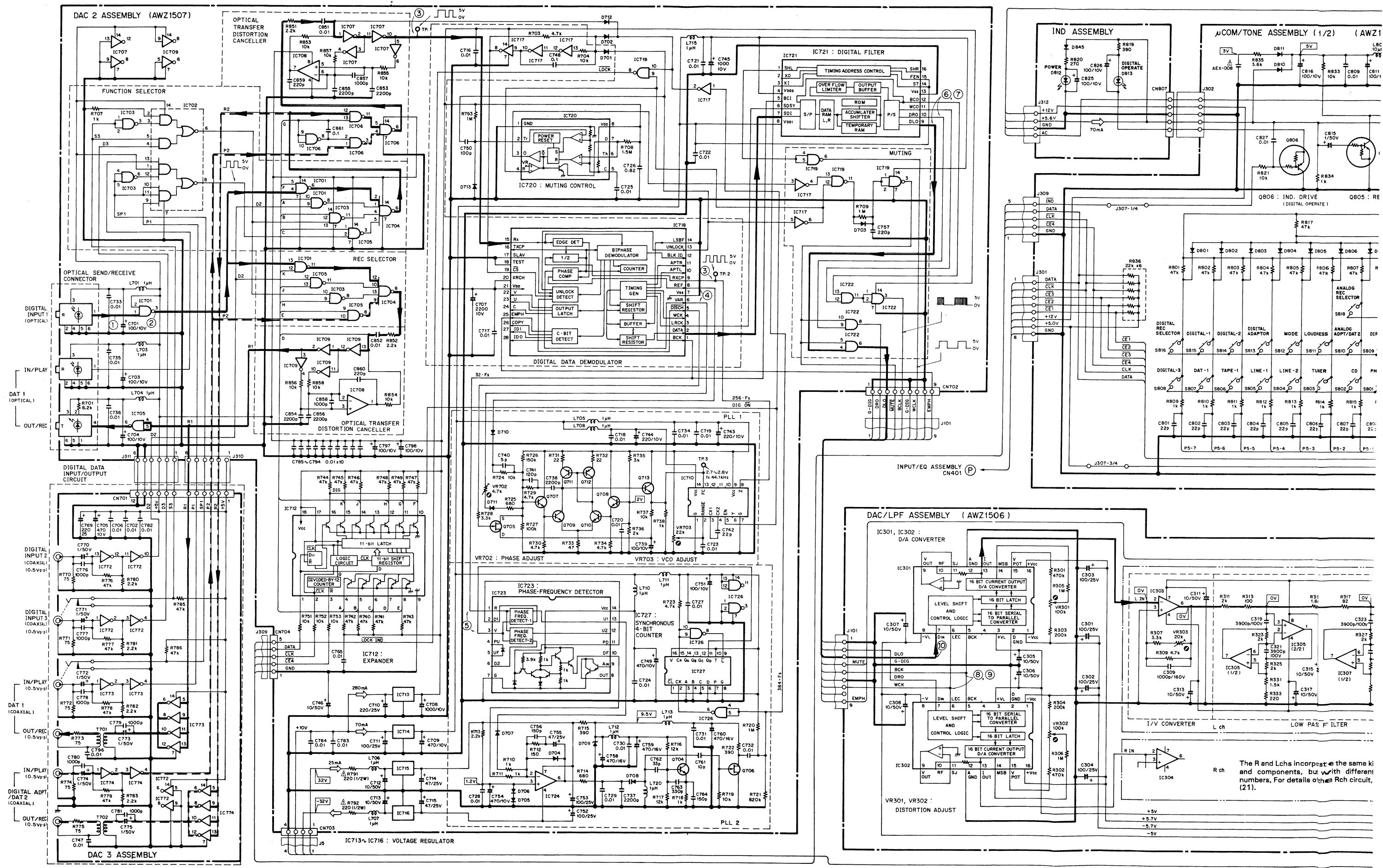

1

2

3

4

5

6

7

The R and Lch's incorporate the same ki and components, but with different numbers. For details of the Rch circuit, (21).

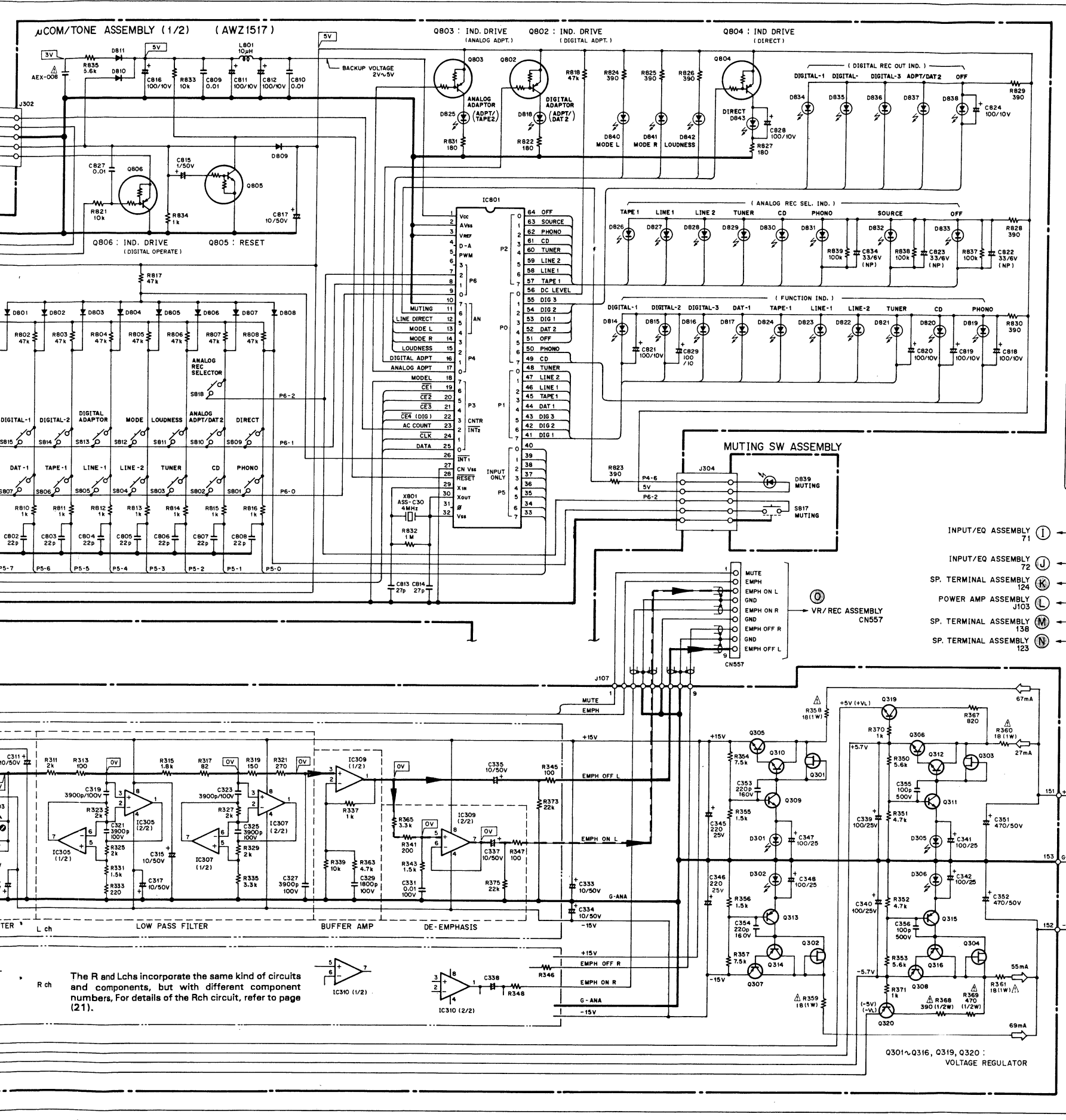

Note: concerning IC801
 • The system control's IC801 (PD5055) oscillates a system clock at pins 29 and 30 and carries out key scanning only when the control key is pressed. When INT1 is set to LOW, IC801 releases the pressed key and, maintaining each port in the same state, enters the backup mode to stop the system clock.
 • The required backup voltage (at pin 1) in case of power failure ranges from 2V to 5V inclusively.

A

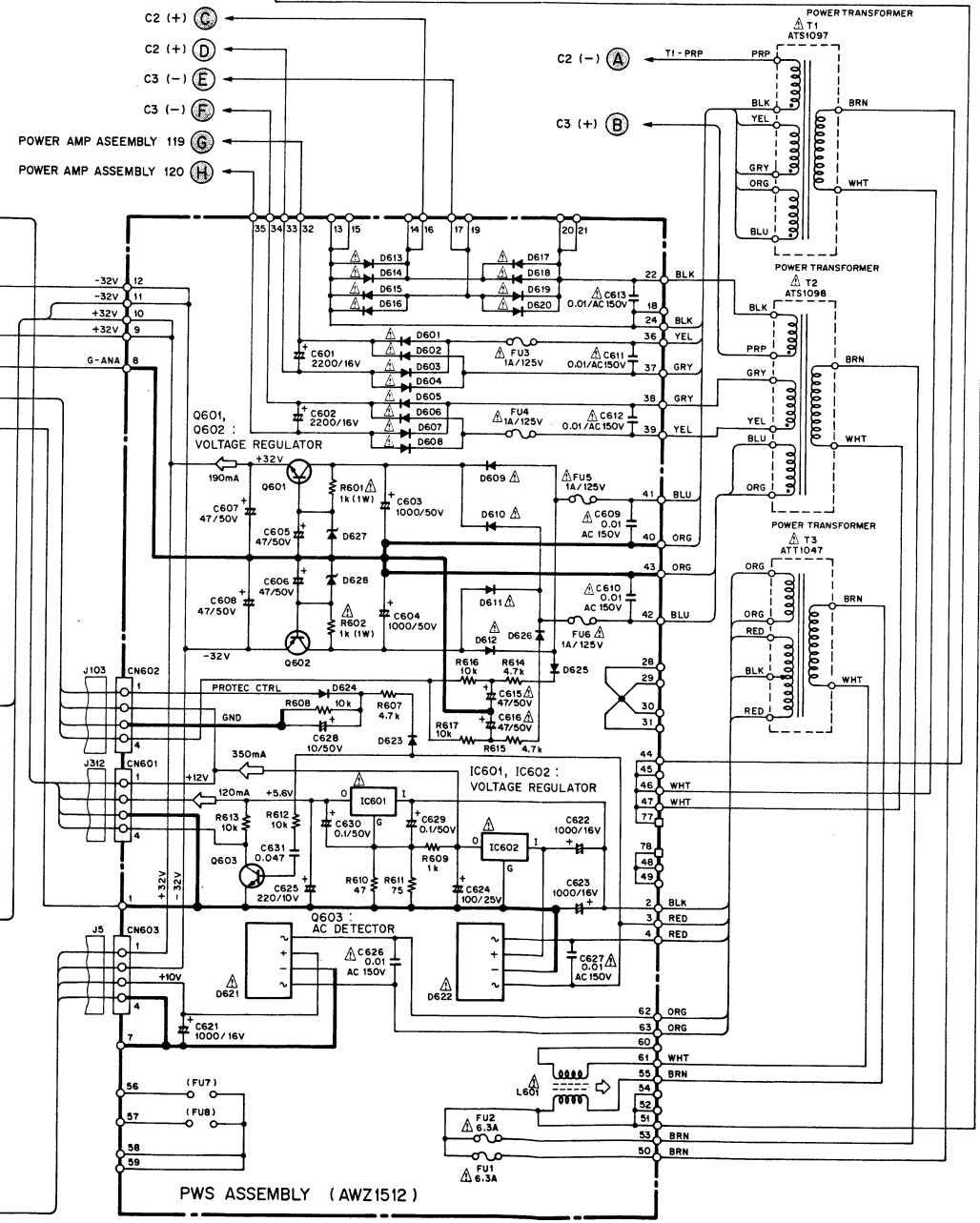
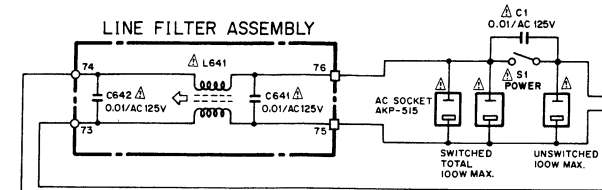

B

C

D

The R and Lchs incorporate the same kind of circuits and components, but with different component numbers. For details of the Rch circuit, refer to page (21).

Q301~Q316, Q319, Q320 : VOLTAGE REGULATOR

PWS ASSEMBLY (AWZ1512)

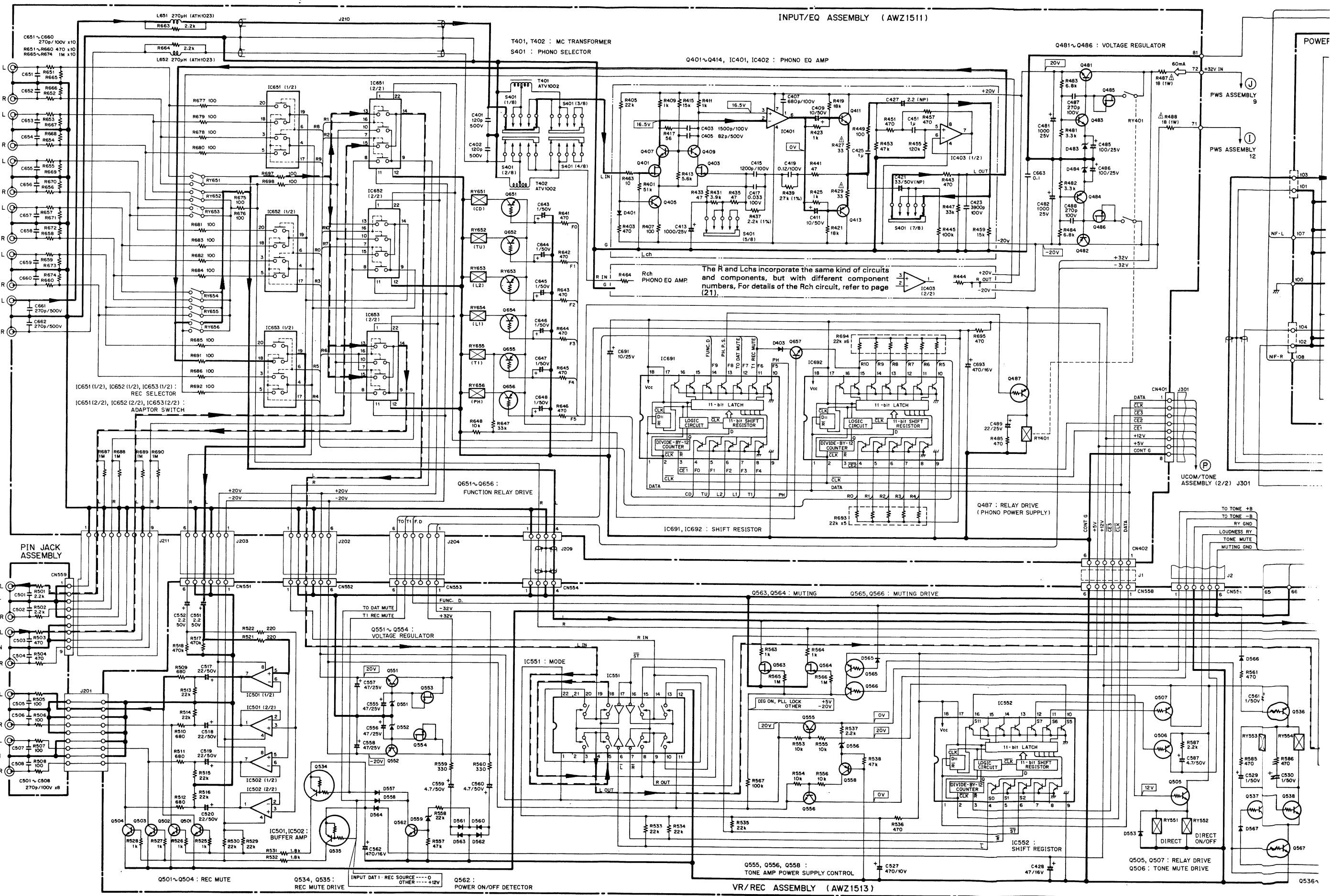

A

B

C

D

POWER

INPUT/EQ ASSEMBLY (AWZ1511)

Q481~Q486 : VOLTAGE REGULATOR

T401, T402 : MC TRANSFORMER
S401 : PHONO SELECTOR

Q401~Q414, IC401, IC402 : PHONO EQ AMP

The R and Lchs incorporate the same kind of circuits and components, but with different component numbers. For details of the Rch circuit, refer to page (21).

Q651~Q656 : FUNCTION RELAY DRIVE

IC691, IC692 : SHIFT RESISTOR

Q487 : RELAY DRIVE (PHONO POWER SUPPLY)

PIN JACK ASSEMBLY

ADPT/TAPE 2

TAPE 1 REC

TO DAT 1

IC501, IC502 : BUFFER AMP

Q501~Q504 : REC MUTE

Q534, Q535 : REC MUTE DRIVE

Q551 ~ Q554 : VOLTAGE REGULATOR

Q555, Q556, Q558 : TONE AMP POWER SUPPLY CONTROL

Q505, Q507 : RELAY DRIVE

Q506 : TONE MUTE DRIVE

VR/REC ASSEMBLY (AWZ1513)

Q536

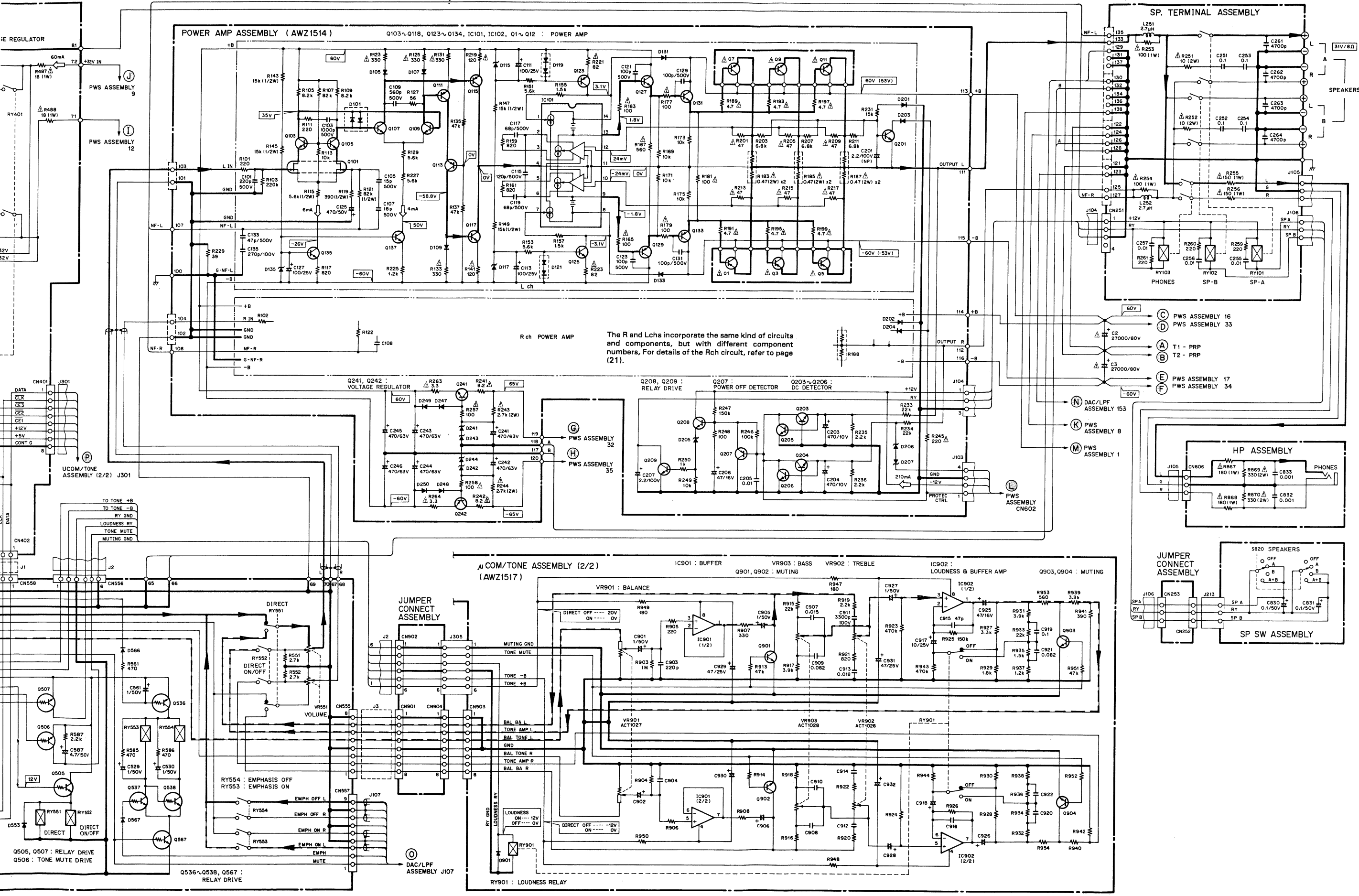

A

B

C

D

R ch POWER AMP

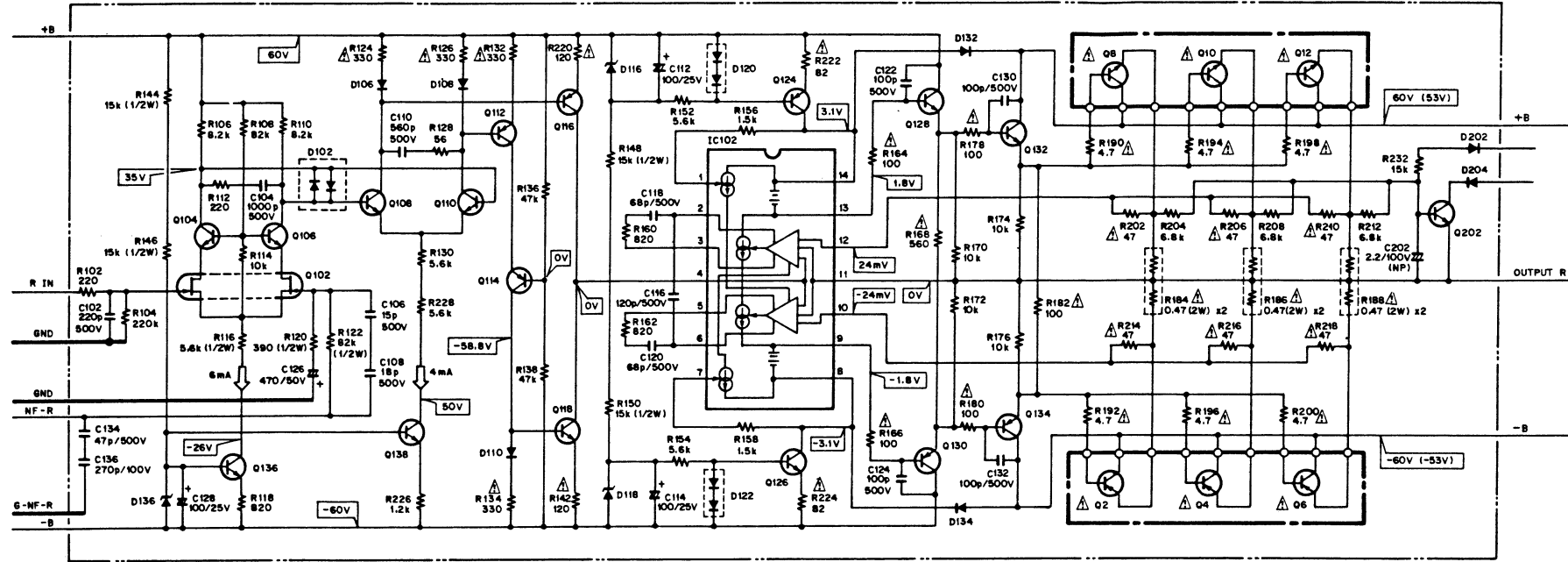

R ch PHONO EQ AMP

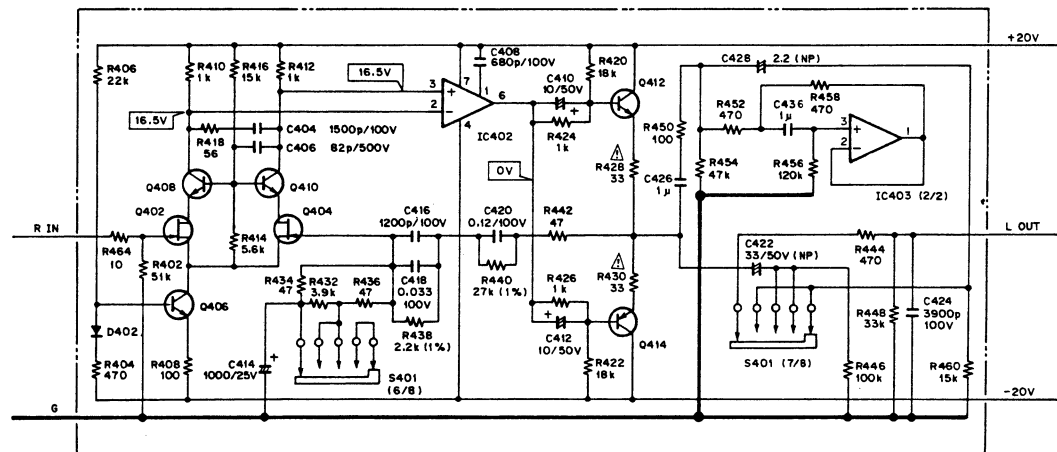

R ch I/V CONVERTER, LOW PASS FILTER, BUFFER AMP, DE-EMPHASIS

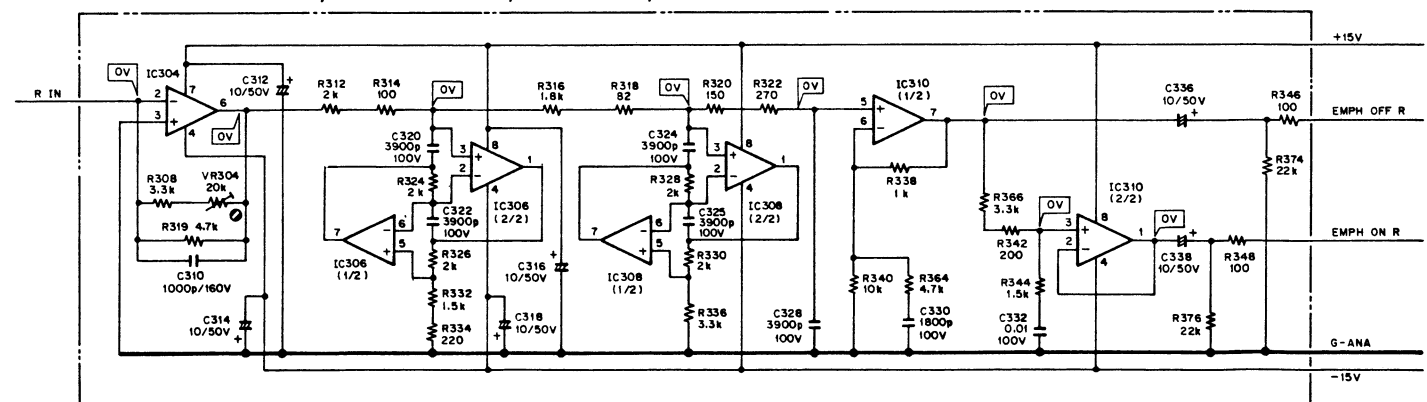

1. RESISTORS:
Indicated in Ω , $\frac{1}{4}W$, $\frac{1}{2}W$, $\pm 5\%$ tolerance unless otherwise noted k : k Ω , M : M Ω , (F) : $\pm 1\%$, (G) : $\pm 2\%$, (K) : $\pm 10\%$ (M) : $\pm 20\%$ tolerance

2. CAPACITORS:
Indicated in capacity (μF)/voltage (V) unless otherwise noted p : pF Indication without voltage is 50V except electrolytic capacitor.

3. VOLTAGE, CURRENT:
□ : Signal voltage at (W + W Ω) out (1KHz)
□ : DC voltage (V) at no input signal
Value in () is DC voltage at rated power.
← mA : DC current at no input signal

4. OTHERS:
→ : Signal route.
The Δ mark found on some component parts indicates the importance of the safety factor of the part. Therefore, when replacing, be sure to use parts of identical designation.

5. SWITCHES
INPUT/EQ assembly
S401 : PHONO SELECTOR
 MC SUBSONIC - MC -
 MH - MH SUBSONIC
RY401 : PHONO AMP POWER SUPPLY
 CONTROL ON - OFF

SP SW assembly
S820 : SPEAKER SELECT
 OFF - A - B - A+B

μ COM/TONE assembly
S801 : PHONO
S802 : CD
S803 : TUNER
S804 : LINE-2
S805 : LINE-1
S806 : TAPE-1
S807 : DAT-1
S808 : DIGITAL-3
S809 : DIRECT
S810 : ANALOG ADPT/DAT2
S811 : LOUDNESS
S812 : MODE
S813 : DIGITAL ADAPTOR
S814 : DIGITAL-2
S815 : DIGITAL-1
S816 : DIGITAL REC SELECTOR
S818 : ANALOG REC SELECTOR
RY901 : LOUDNESS ON - OFF

Muting sw assembly
S817 : MUTING

VR/REC assembly
RY551 : DIRECT ON - OFF
RY552 : DIRECT ON/OFF ON - OFF
RY553 : EMPHASIS ON ON - OFF
RY554 : EMPHASIS OFF ON - OFF

SP.Terminal assembly
RY101 : SPEAKER A ON - OFF
RY102 : SPEAKER B ON - OFF
RY103 : PHONES MUTE ON - OFF

OTHER
S1 : POWER ON - OFF

The underlined indication the switch position

A

E

C

C

7. P.C. BOARDS CONNECTION DIAGRAM

A

B

C

D

INPUT/EQ ASSEMBLY (AWZ 1511)

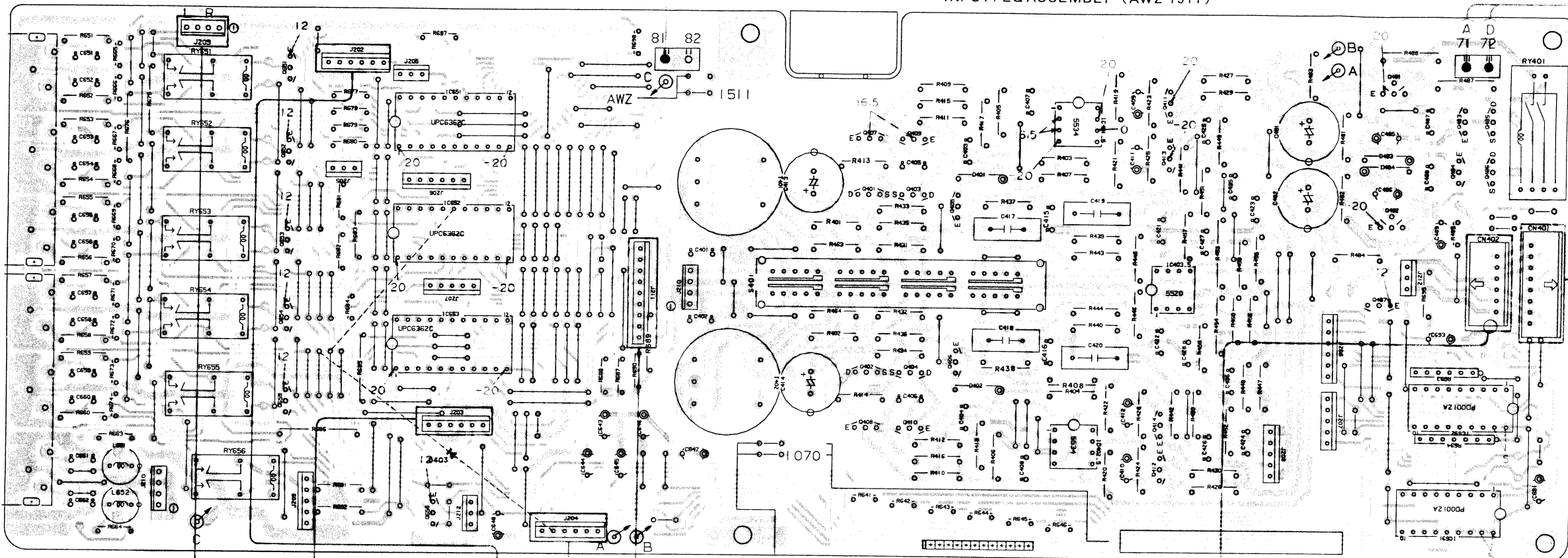

Q615 Q651
Q653
Q655 Q654

IC651
IC652
IC653
Q656

Q407 Q409
Q401 Q403
Q402 Q404
Q408 Q401

IC401 Q413 Q411
IC403

IC402 Q414 Q412

Q481 Q483-486
Q482
Q487 IC692
IC691

Q653-Q656

IC551

Q537

Q562

Q501

Q535

Q502

IC501 Q534

Q503

IC502 Q551

Q504

Q553

Q505

Q538

Q536

Q535

Q534

IC552

Q551 Q552

Q507 Q506

Q553 Q554

Q555

Q558

Q556

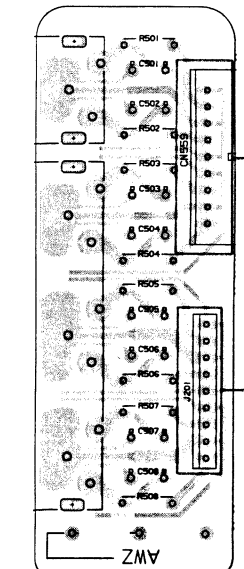

PIN-JACK ASSEMBLY

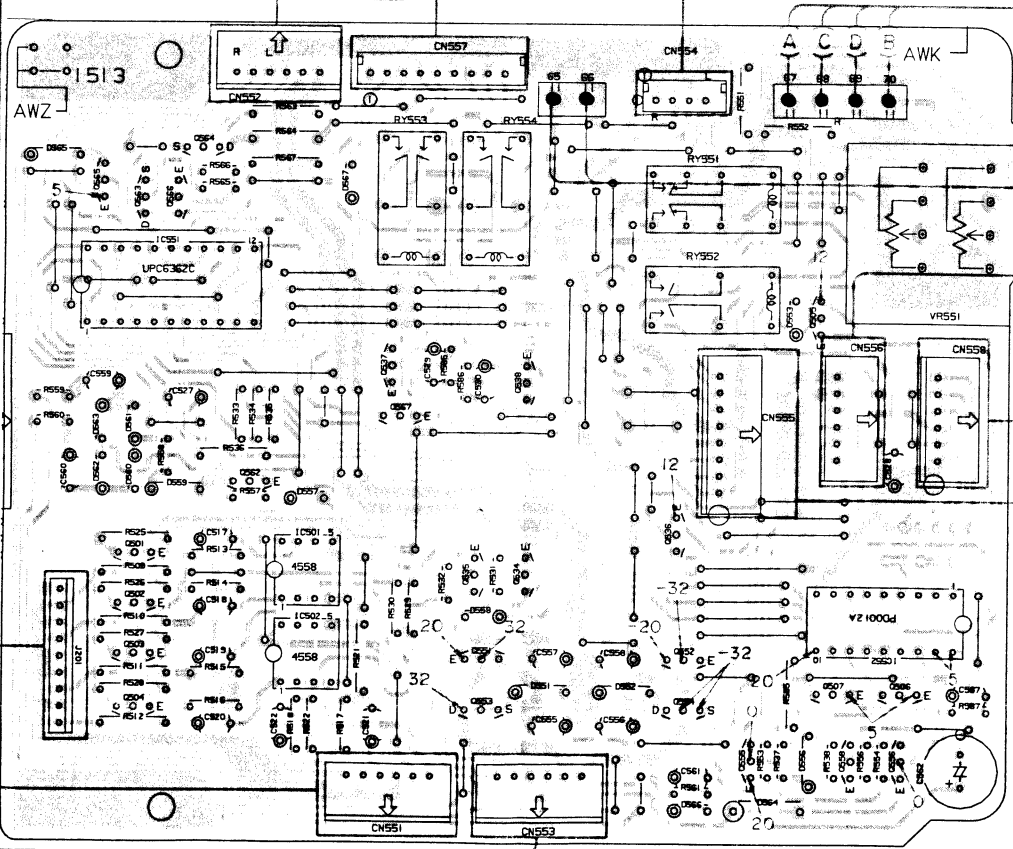

VR/REC ASSEMBLY (AWZ 1513)

JUMPER CONNECT ASSEMBLY

IND ASSEMBLY

COM/TONE ASS (AW)

1

2

3

4

5

6

7

7

8

9

10

11

12

Q302 Q314 Q307 Q304 Q315 Q316 Q308 Q320 IC302 IC304 IC306 IC308 IC310
 Q313 Q301 Q309 Q310 Q305 Q303 Q311 Q312 Q306 Q319 IC301 IC303 IC305 IC307 IC309

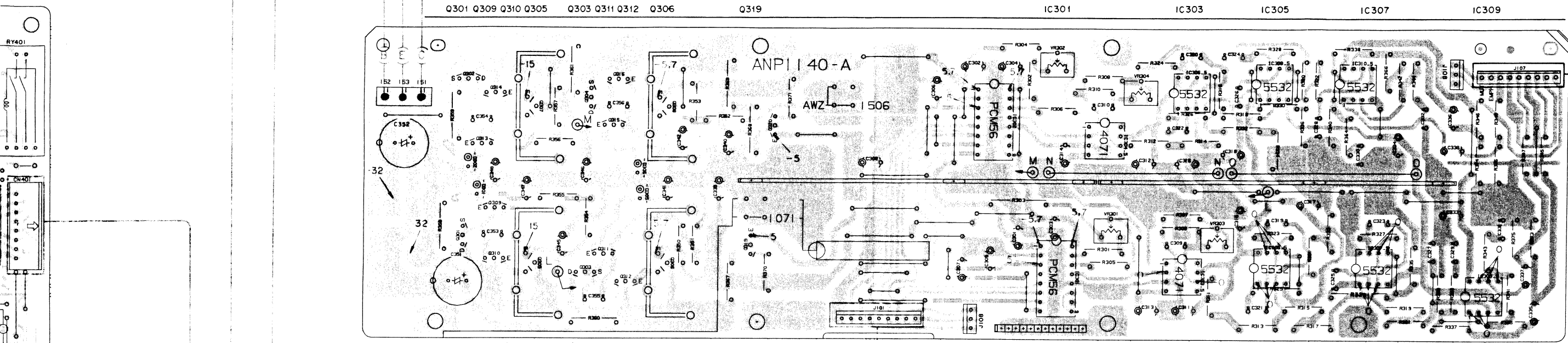

DAC/LPF ASSEMBLY (AWZ 1506)

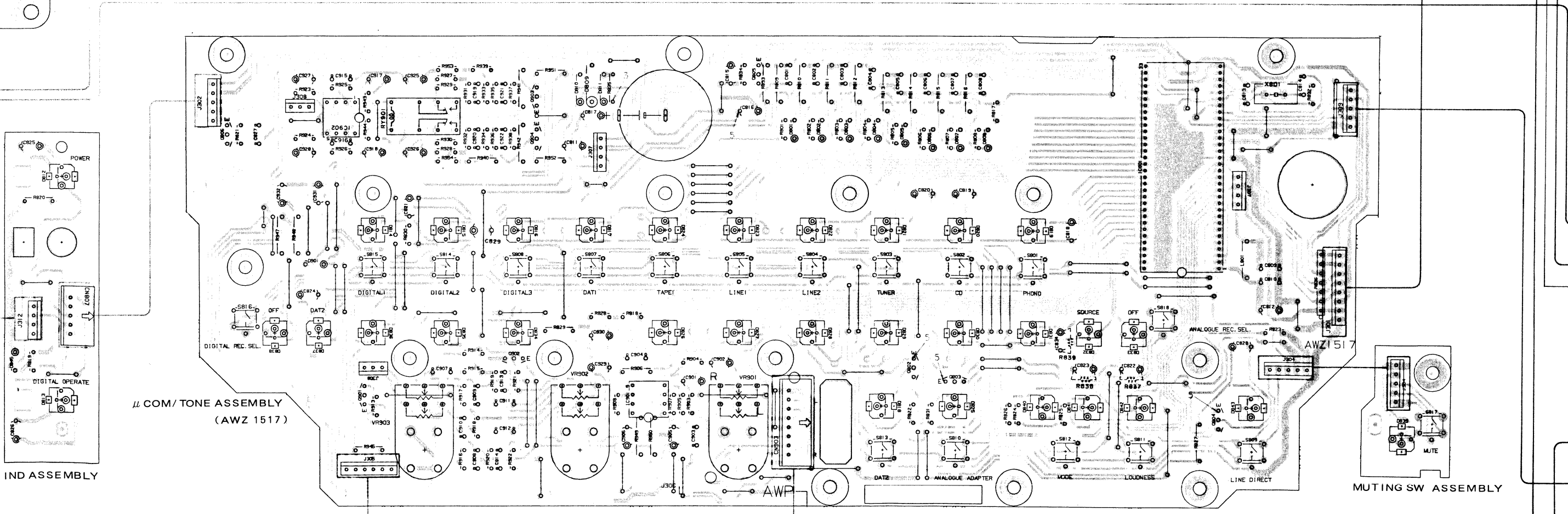

II COM/TONE ASSEMBLY (AWZ 1517)

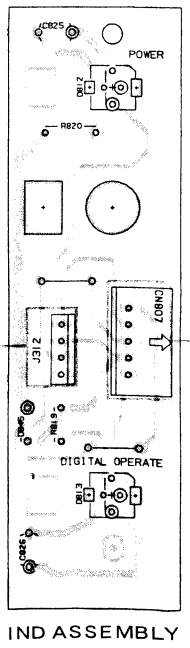

IND ASSEMBLY

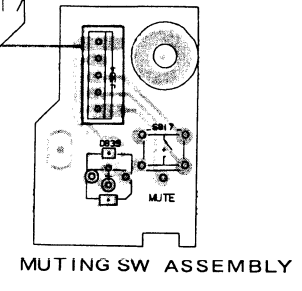

MUTING SW ASSEMBLY

A

B

C

D

E

F

G

7

8

9

10

11

12

1

2

3

4

5

6

Q133 Q125 Q129 IC101 Q123 Q127 Q131 Q201 Q209 Q202 Q132 Q128 Q124 IC102 Q126 Q130 Q134 Q122
 Q115 Q111 Q113 Q107 Q109 Q117 Q135-138 Q118 Q110 Q108 Q114 Q112 Q116 Q203-207 Q241 Q242
 Q105 Q103 Q101 Q102 Q106 Q104

A

B

C

D

E

F

G

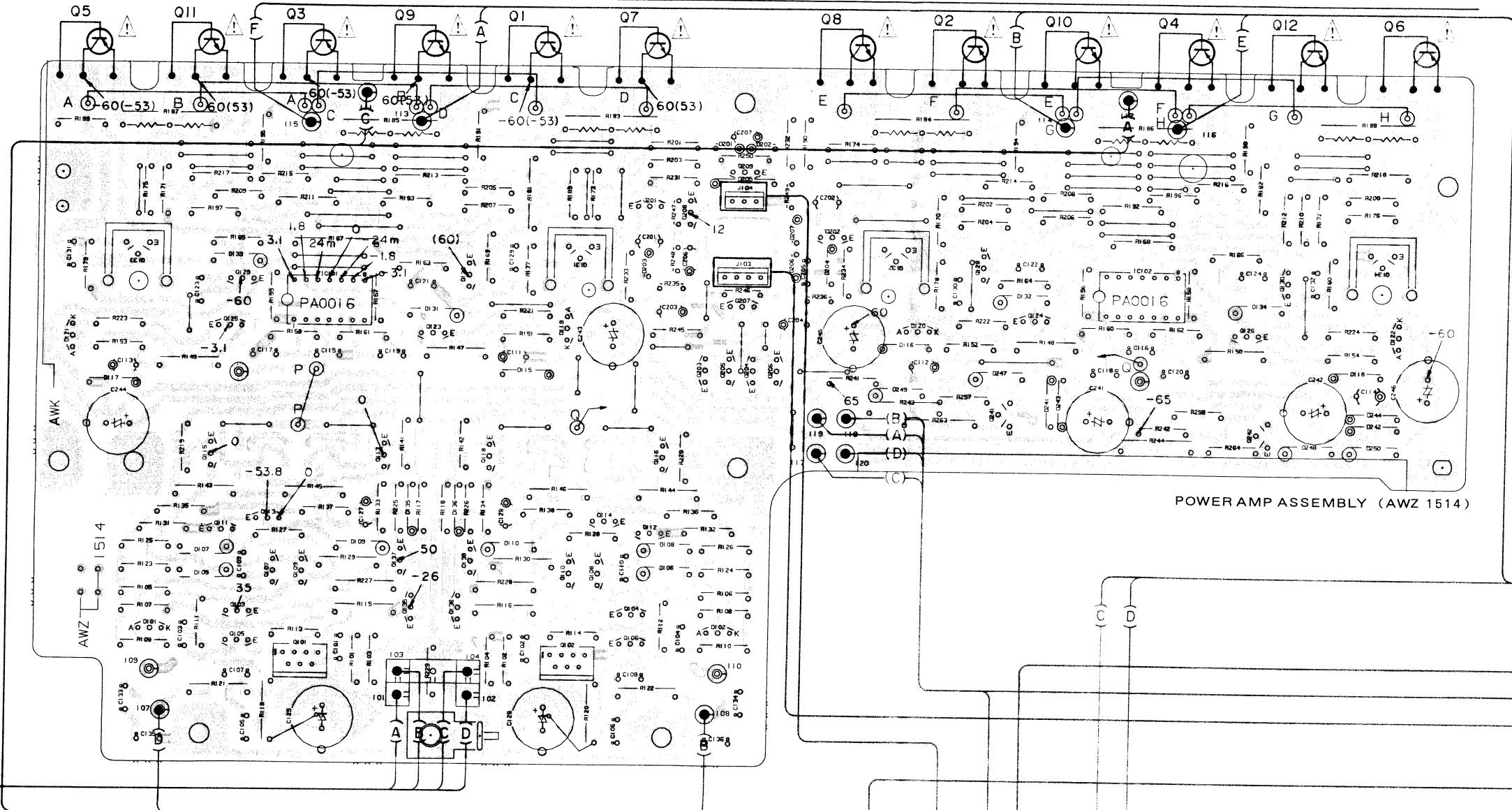

POWER AMP ASSEMBLY (AWZ 1514)

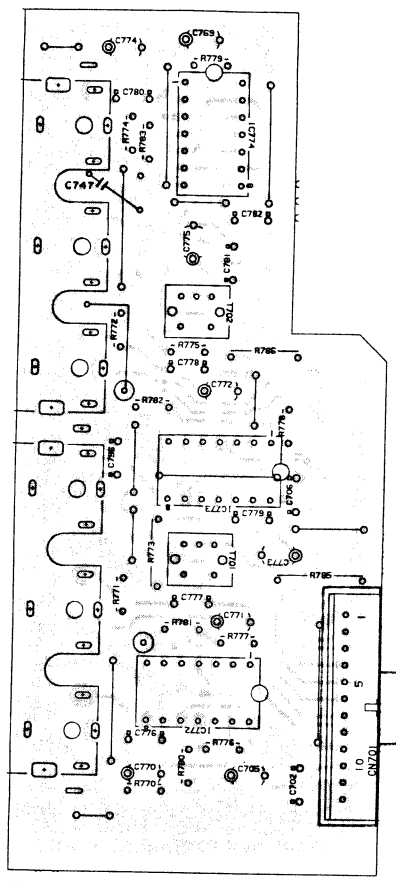

DAC3 ASSEMBLY

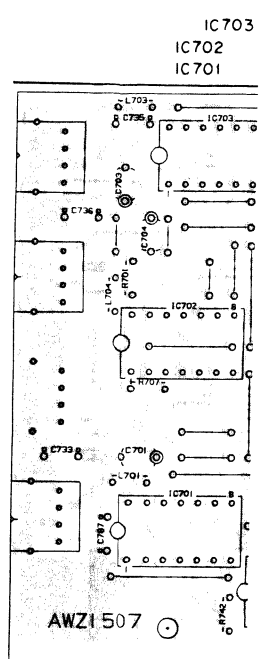

AWZ 1507

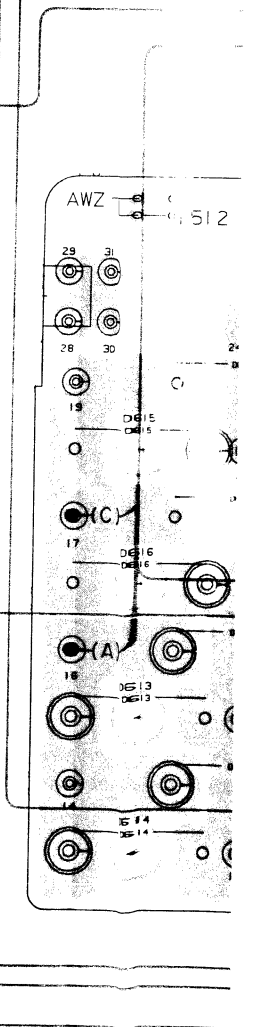

SP TERMINAL ASSEMBLY

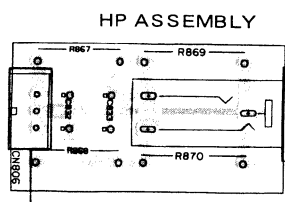

HP ASSEMBLY

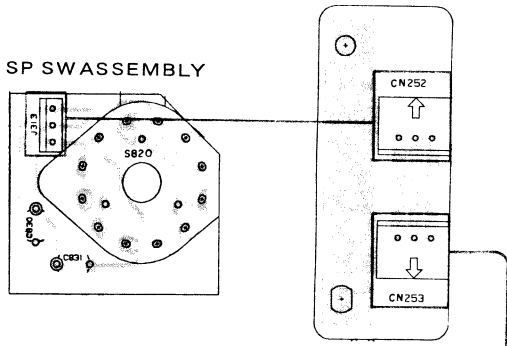

SP SWASSEMBLY

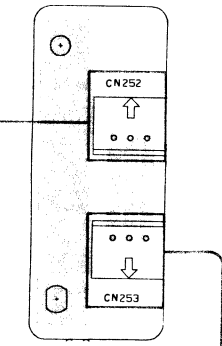

JUMPER CONNECT ASSEMBLY

1

2

3

4

5

6

6

7

8

9

10

11

12

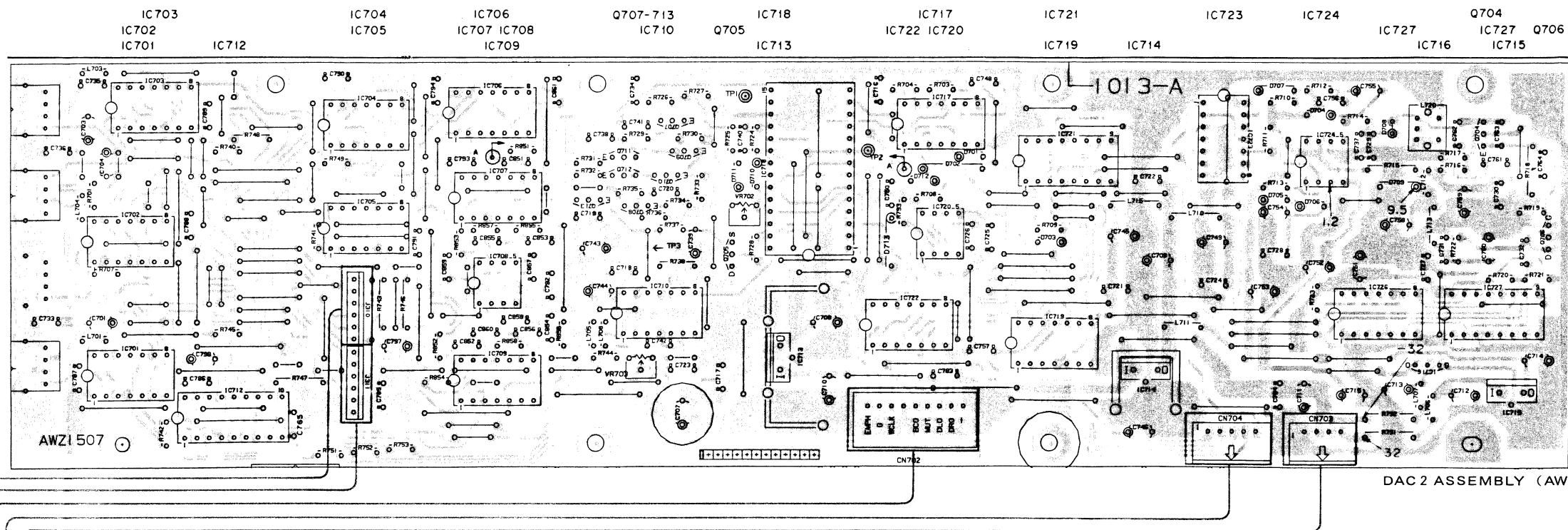

DAC 2 ASSEMBLY (AWZ 1507)

NOTE
 1. This P.C.B. connection diagram is viewed from the parts mounted side.
 2. The parts which have been mounted on the board can be replaced with those shown with the corresponding wiring symbols listed in the following Table.

P.C.B. pattern diagram indication	Corresponding part symbol	Part Name
		Transistor
		Radiator type transistor
		Diode
		Resistor
		Capacitor (Polarity)
		Capacitor (Nonpolarity)

Others

P.C.B. pattern diagram indication	Part Name
IC	IC
S	Switch
RY	Relay
L	Coil
F	Filter
VR	Variable resistor or Semi-fixed resistor

3. The capacitor terminal marked with ⊖ (double circles) shows negative terminal.
 4. The diode terminal marked with ⊖ (double circles) shows cathode side.
 5. The transistor terminal to which E is affixed shows the emitter.

6

7

8

9

10

11

12

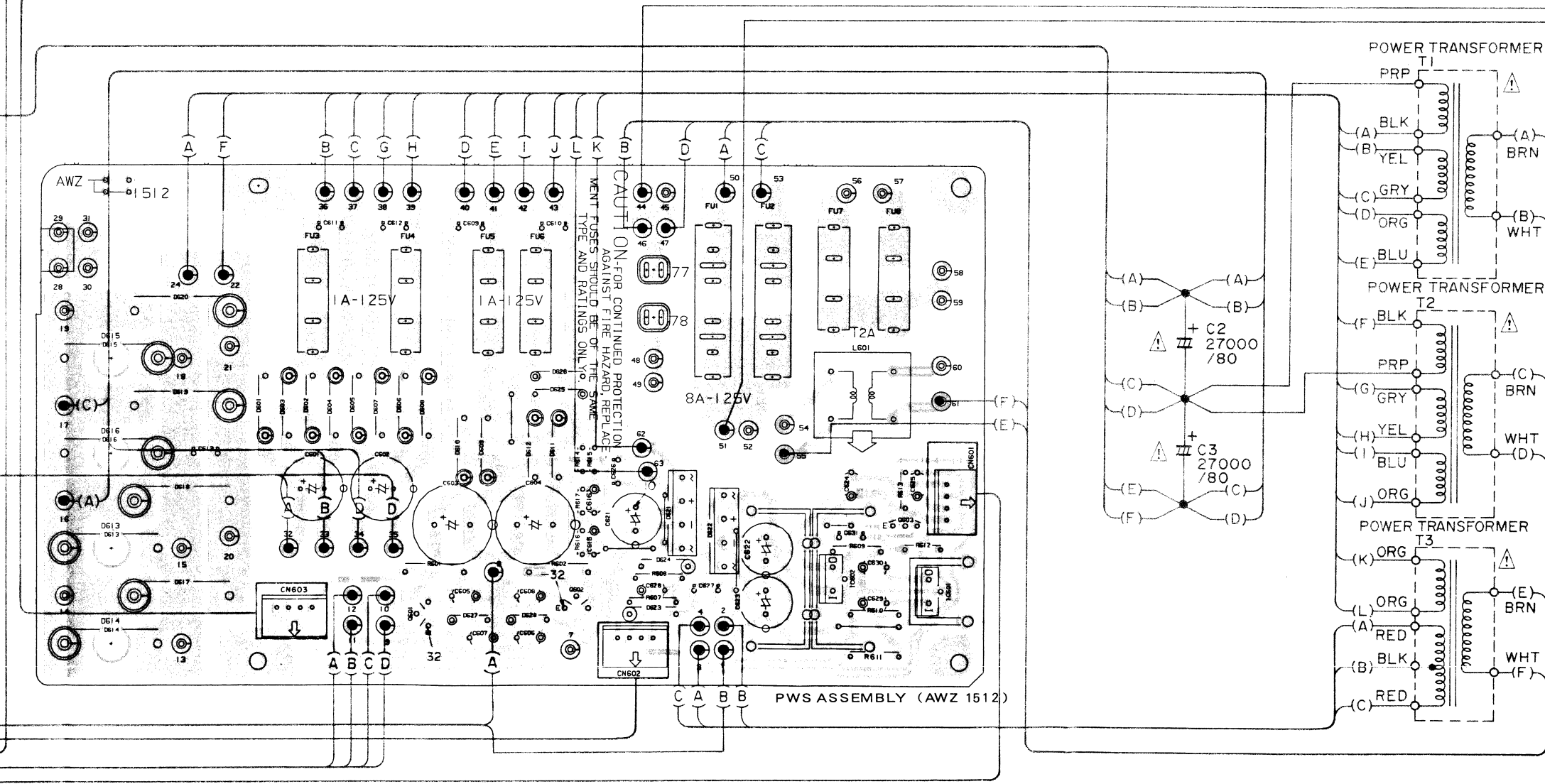

PWS ASSEMBLY (AWZ 1512)

POWER TRANSFORMER

POWER TRANSFORMER

POWER TRANSFORMER

LINE FILTER ASSEMBLY

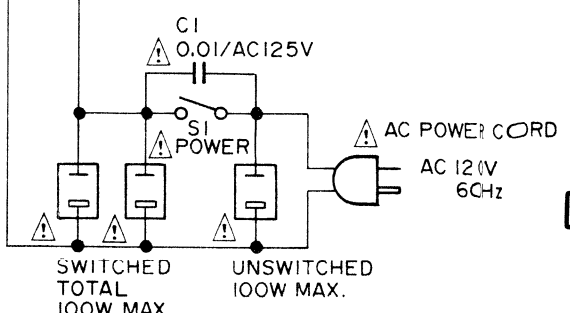

SWITCHED TOTAL 100W MAX
 UNSWITCHED 100W MAX.

A

B

C

D

8. IMAGE DIAGRAM

DIGITAL SECTION

OPTICAL SEND/RECEIVE CONNECTOR

A

B

C

D

Note: The switch controlled by control terminals Ⓐ to Ⓜ and Ⓢ is turned ON with the CMOS level's LOGIC set to H, and OFF with the LOGIC set to L.

Note: FDNR (frequency dependent negative resistance) refers to the characteristic of a resistance value that decreases as frequency increases.

ANALOG SECTION

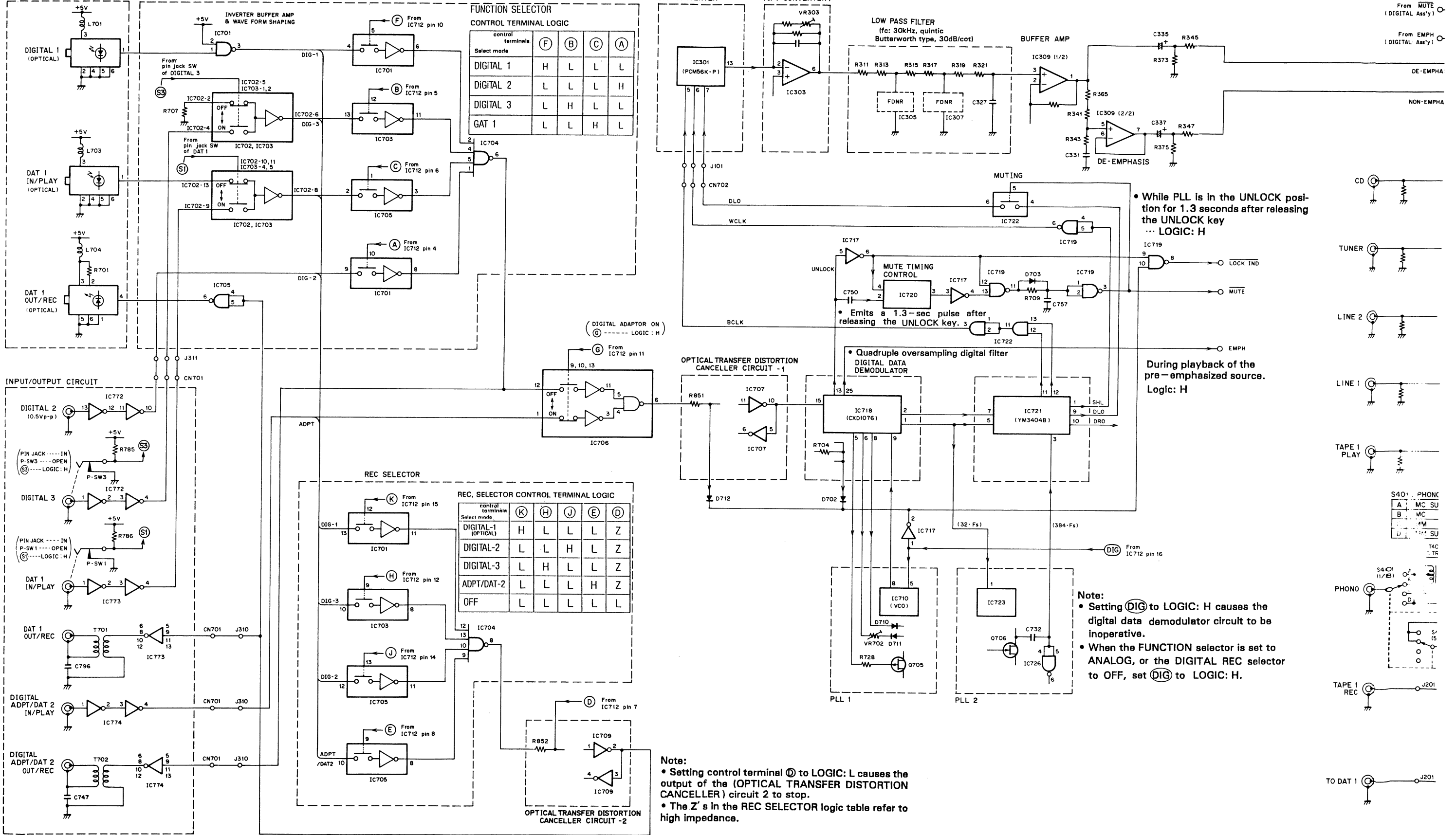

FUNCTION SELECTOR CONTROL TERMINAL LOGIC

Select mode	F	B	C	A
DIGITAL 1	H	L	L	L
DIGITAL 2	L	L	L	H
DIGITAL 3	L	H	L	L
GAT 1	L	L	H	L

REC. SELECTOR CONTROL TERMINAL LOGIC

Select mode	K	H	J	E	D
DIGITAL-1 (OPTICAL)	H	L	L	L	Z
DIGITAL-2	L	L	H	L	Z
DIGITAL-3	L	H	L	L	Z
ADPT/DAT-2	L	L	L	H	Z
OFF	L	L	L	L	L

• While PLL is in the UNLOCK position for 1.3 seconds after releasing the UNLOCK key ... LOGIC: H

• Emits a 1.3-sec pulse after releasing the UNLOCK key.

• Quadruple oversampling digital filter

During playback of the pre-emphasized source. Logic: H

Note:
 • Setting DIG to LOGIC: H causes the digital data demodulator circuit to be inoperative.
 • When the FUNCTION selector is set to ANALOG, or the DIGITAL REC selector to OFF, set DIG to LOGIC: H.

Note:
 • Setting control terminal Ⓜ to LOGIC: L causes the output of the (OPTICAL TRANSFER DISTORTION CANCELLER) circuit 2 to stop.
 • The Z's in the REC SELECTOR logic table refer to high impedance.

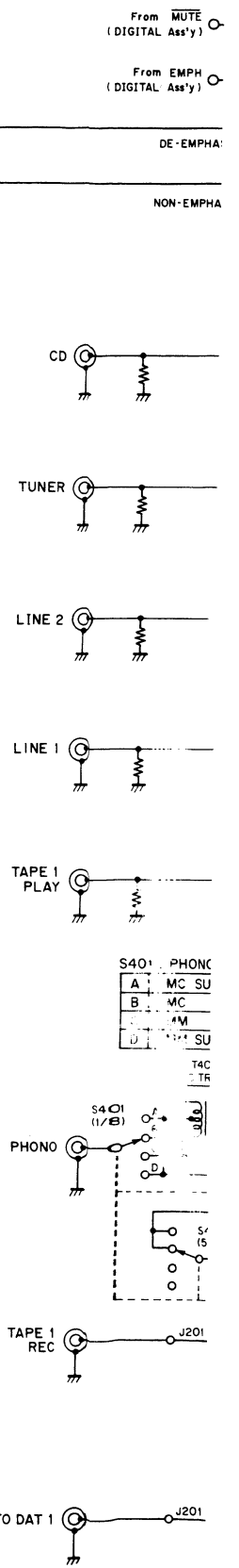

ANALOG SECTION

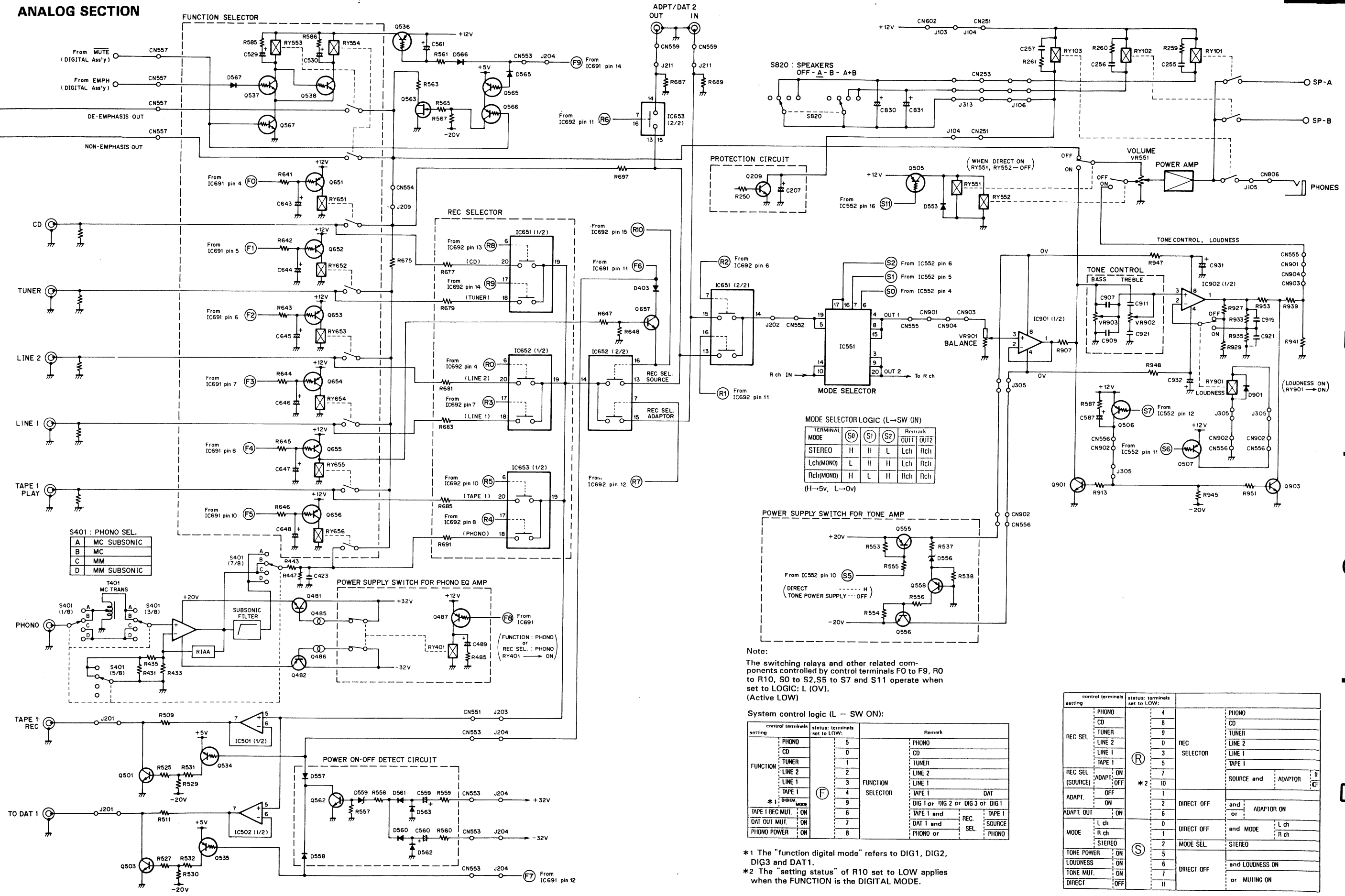

MODE SELECTOR LOGIC (L → SW ON)

TERMINAL MODE	(S0)	(S1)	(S2)	OUT1	OUT2
STEREO	H	H	L	Lch	Rch
Lch(MONO)	L	H	H	Lch	Rch
Rch(MONO)	H	L	H	Hch	Rch

(H → +5v, L → 0v)

Note:
The switching relays and other related components controlled by control terminals F0 to F9, R0 to R10, S0 to S2, S5 to S7 and S11 operate when set to LOGIC: L (0V). (Active LOW)

System control logic (L - SW ON):

control terminals setting	status: terminals set to LOW:	Remark
PHONO	5	PHONO
CD	0	CD
TUNER	1	TUNER
LINE 2	2	LINE 2
LINE 1	3	LINE 1
TAPE 1	4	TAPE 1
FUNCTION SELECTION	9	DIG 1 or DIG 2 or DIG 3 or DIG 1
TAPE 1 REC MUT. ON	6	TAPE 1 and REC. TAPE 1
DAT OUT MUT. ON	7	DAT 1 and SEL. SOURCE
PHONO POWER ON	8	PHONO or SEL. PHONO

*1 The "function digital mode" refers to DIG1, DIG2, DIG3 and DAT1.
*2 The "setting status" of R10 set to LOW applies when the FUNCTION is the DIGITAL MODE.

control terminals setting	status: terminals set to LOW:	Remark
PHONO	4	PHONO
CD	8	CD
TUNER	9	TUNER
LINE 2	0	LINE 2
LINE 1	3	LINE 1
TAPE 1	5	TAPE 1
REC SEL (SOURCE)	7	SOURCE and ADAPTOR
ADAPT. OFF	* 2 10	ADAPTOR ON
ADAPT. ON	1	ADAPTOR ON
ADAPT OUT ON	2	DIRECT OFF and ADAPTOR ON
MODE	0	DIRECT OFF and MODE
STEREO	1	and MODE
MODE SEL.	2	and MODE
STEREO	5	and MODE
TONE POWER ON	6	and TONE POWER ON
LOUDNESS ON	6	and LOUDNESS ON
TONE MUT. ON	7	DIRECT OFF or MUTING ON
DIRECT OFF	11	

9. ELECTRICAL PARTS LIST

NOTES:

- Parts without part number cannot be supplied.
 - Parts marked by "⊙" are not always kept in stock. Their delivery time may be longer than usual or they may be unavailable.
 - The Δ mark found on some component parts indicates the importance of the safety factor of the part. Therefore, when replacing, be sure to use parts of identical designation.
 - For your parts Stock Control, the fast moving items are indicated with the marks ★★ and ★.
- ★★ **GENERALLY MOVES FASTER THAN ★**
 This classification shall be adjusted by each distributor because it depends on model number, temperature, humidity, etc.

When ordering resistors, first convert resistance values into code form as shown in the following examples.

Ex. 1 When there are 2 effective digits (any digit apart from 0), such as 560 ohm and 47k ohm (tolerance is shown by J = 5%, and K = 10%).

560Ω	56 × 10 ¹	561.....	RD1/4PS	Ⓜ	Ⓜ	J
47kΩ	47 × 10 ³	473.....	RD1/4PS	Ⓜ	Ⓜ	J
0.5Ω	0R5.....		RN2H	Ⓜ	Ⓜ	K
1Ω	010.....		RS1P	Ⓜ	Ⓜ	K

Ex. 2 When there are 3 effective digits (such as in high precision metal film resistors).

5.62kΩ	562 × 10 ¹	5621.....	RN1/4SR	Ⓜ	Ⓜ	Ⓜ	F
--------	-----------------------	-----------	---------	---	---	---	---

Miscellaneous Parts P,C,BOARD ASSEMBLIES.

Mark	Symbol & Description	Part No.
	POWER AMP assembly	AWZ1514
	DAC 2 assembly	AWZ1507
	VR/REC assembly	AWZ1513
	INPUT/EQ assembly	AWZ1511
	PWS assembly	AWZ1512
	DAC/LPF assembly	AWZ1506
	μCOM/TONE assembly	AWZ1517
	SP.Terminal assembly	
	Pin Jack assembly	
	HP assembly	
	IND assembly	
	Muting sw assembly	
	Jumper connect assembly	
	SP SW assembly	
	DAC 3 assembly	
	Line filter assembly	
	Jumper connect assembly	

OTHERS

Mark	Symbol & Description	Part No.
△★★★	Q1-Q6	2SA1265NP
△★★★	Q7-Q12	2SC3182NP
△	C1 Ceramic capacitor (0.01/125V)	ACG1003
△	C2,C3 Electrolytic capacitor (27000μF/80V)	ACH1046
△★	T1 POWER transformer(120V)	ATS1097
△★	T2 POWER transformer(120V)	ATS1098
△★	T3 POWER transformer(120V)	ATS1047
△	AC socket(OUTLETS,3p)	AKP-515

Mark	Symbol & Description	Part No.
△★★★	S1 Push switch(POWER)	ASG-553
★★	S2 Remote slide rotary switch (REC SELECTOR)	ASU1004
△★★★	FU3-FU6 Fuse(1A/125V)	AEK-119
△★★★	FU1,FU2 Fuse(6.3A/125V)	AEK-309
△	AC Power cord	ADG-089

POWER AMP Assembly(AWZ1514) SEMICONDUCTORS

Mark	Symbol & Description	Part No.
★★	IC101,IC102	PA0016
★★	Q207	2SA1115
★★	Q115,Q116,Q123,Q124,Q129,Q130	2SA1145
★★	Q133,Q134,Q242	2SA968
★★	Q111-Q114	2SA992
★★	Q103-Q110,Q135-Q138,Q201,Q202,Q208	2SC1845
★★	Q209	2SC2235
★★	Q131,Q132,Q241	2SC2238
★★	Q203-Q206	2SC2603
★★	Q117,Q118,Q125-Q128	2SC2705
★★	Q101,Q102	2SK389
★	D135,D136	HZS6B1L
★	D101,D102,D119-D122	MC931
★	D241-D244	RD30EB (HZ30EB)
★	D206,D207	RD5.6ESB
★	D205	RD6.2ESB
★	D115-D118	RD8.2EB (HZ8.2EB)
★	D131-D134,D201-D204	1SS145
★	D105-D110,D247-D250	11E2

CAPACITORS

Mark	Symbol & Description	Part No.
	C125,C126 (470μF/50V)	ACH1052
	C201,C202	CEANP2R2M100
	C207	CEAS2R2M100
	C206	CEAS470M16
	C203,C204	CEAS471M10
	C111-C114,C127,C128	CEXA101M25
	C133,C134	CMA470J500
	C135,C136	CQPXA271J2A
	C241-C246	CEXA471M63
	C205	CKDYB103K50
	C121-C124,C129-C132	CMA101J500
	C115,C116	CMA121J500
	C105,C106	CMA150J500
	C107,C108	CMA180J500
	C117-C120	CMA680J500
	C103,C104	CQSXA102J160
	C101,C102	CQSXA221J160
	C109,C110	CQSXA561J160

RESISTORS

Mark	Symbol & Description	Part No.
△	R183-R188	ACN-118
△	R167,R168,R257,R258,R263,R264	RD1/4PMF□□□J
△	R123-R126,R131-R134	RD1/4PMF□□□J
	R115,R116,R119-R122,R143-R146	RDR1/2PM□□□J
	R235,R236,R246-R250	RD1/8PM□□□J
△	R243,R244	RS2LMF272J
△	R141,R142,R163-R166,R177-R182,R189-R202,R205,R206,R209,R210,R213-R224,R241,R242,R245	RFA1/4PS□□□J
	R147-R150	RD1/2PM153J
	Other resistor	RDR1/4PM□□□J

DAC 2 Assembly (AWZ1507) SEMICONDUCTORS

Mark	Symbol & Description	Part No.
★★	IC718	CXD1076P
★★	IC723	MC4044P
★★	IC720	M51848P
★★	IC708	M5223P
★★	IC713	NJM7805A
★★	IC716	NJM79LI5A
★★	IC712	PD0012A
★★	IC727	SN74ALS163BN
★★	IC710	SN74LS624N
★★	IC707,C709,C717	TC74HCU04P
★★	IC701,IC703,IC705,IC706,IC719,IC726	TC74HC00P
★★	IC722	TC74HC08P
★★	IC704	TC74HC20P

Mark	Symbol & Description	Part No.
★★	IC702	TC74HC51P
★★	IC724	μPC4071C
★★	IC714	μPC78M05H
★★	IC715	μPC78M15H
★★	IC721	YM3404B
★★	Q711,Q712	2SA1115
★★	Q704	2SC2786
★★	Q707-Q710,Q713	2SC2901
★★	Q705	2SJ74
★★	Q706	2SK241
★	D709	HZS9C3L
★	D708	SVC321SP-AS
★	D707	1SS108
★	D701-D706,D710-D713	1SS131

COILS

Mark	Symbol & Description	Part No.
	L720 COIL	ATX1004
	L701,L703-L708,L710-L712,L713,L715	LAU010M
	Inductor(1μH)	

CAPACITORS

Mark	Symbol & Description	Part No.
	C740	CCDCH050C50
	C761	CCDCH100D50
	C741	CCDCH121J50
	C756,C764	CCDCH151J50
	C742	CCDCH220J50
	C762	CCDCH330J50
	C757,C859,C860	CCDSL221J50
	C712,C713,C746	CEAS100M50
	C739,C751,C797	CEAS101M10
	C711,C752,C753	CEAS101M25
	C708,C745	CEAS102M10
	C743,C744	CEAS221M10
	C710	CEAS221M25
	C707	CEAS222M10
	C714,C715,C755	CEAS470M25
	C709,C749,C754	CEAS471M10
	C758,C759,C760	CEAS471M16
	C701,C703,C704,C798	CEJA101M10
	C748,C861	CFTXA104J50
	C726	CFTXA824J50
	C857,C858	CKDYB102K50
	C716-C724,C727-C734,C736,C783-C794,C851,C852	CKDYB103K50
	C737,C738,C853-C856	CKDYB222K50
	C763	CKDYB331K50
	C725,C735,C765	CKDYF103Z50
	C750	CCDSL101J50

RESISTORS

Mark	Symbol & Description	Part No.
	VR703 Semifixed resistor	VRTS6HS223
	VR702 Semifixed resistor	VRTS6HS472
	R791, R792	RD1/2PMF221J
	other resistors	RD1/8PM□□□J

OTHERS

Mark	Symbol & Description	Part No.
	Light emitting module	AKX1014
	Light receiving module	AKX1015

VR/REC Assembly(AWZ1513)

SEMICONDUCTORS

Mark	Symbol & Description	Part No.
★★	IC501, IC502	NJM4558DXC
★★	IC552	PD0012A
★★	IC551	μPD6362C
★★	Q537, Q538, Q567	RN1201 (DTC143ES)
★★	Q505 - Q507, Q534 - Q536	RN2201 (DTA143ES)
★★	Q565, Q566	RN2203 (DTA124ES)
★★	Q555, Q558	2SA933S (2SA1115)
★★	Q552	2SA965
★★	Q556, Q562	2SC1740S (2SC2603)
★★	Q551	2SC2235
★★	Q501 - Q504	2SC2878
★★	Q553, Q554, C563, C564	2SK246
★	D556	RD10EB (HZ10EB)
★	D551, D552	RD20ESB2
★	D559	RD4.7EB (HZ4.7EB)
★	D553, D557, D558, D560 - D563, D565 - D567	1SS131
★	D564	11E2

RELAYS

Mark	Symbol & Description	Part No.
	RY551 Relay(DIRECT)	ASR-088
	RY552 - RY554 Relay(LOUDNESS/ EMPM ON OFF)	ASR1007

CAPACITORS

Mark	Symbol & Description	Part No.
	C529, C530, C561	CEASO10M50
	C559, C560, C587	CEAS4R7M50
	C528	CEAS470M10
	C527	CEAS471M10
	C562	CEAS471M16
	C521, C522	CEXA2R2M50
	C517 - C520	CEXA220M50
	C555 - C558	CEXA470M25

RESISTORS

Mark	Symbol & Description	Part No.
	VR551 Variable resistor (60kΩ × 2) Volume	ACW1003
	R551, R552	RDR1/4PM272J
	R536	RD1/4PM471J
	R509 - R518, R521, R522	RDR1/6PU□□□J
	R563, R564	
	Other resistor	RD1/8PM□□□J

INPUT/EQ Assembly(AWZ1511)

SEMICONDUCTORS

Mark	Symbol & Description	Part No.
★★	IC403	M5220P
★★	IC401, IC402	NJM5534DD
★★	IC691, IC692	PD0012A
★★	IC651, IC652, IC653	μPD6362C
★★	Q487, Q651 - Q656	RN2201 (DTA143ES)
★★	Q413, Q414	2SA965
★★	Q482	2SA968
★★	Q484	2SA992
★★	Q405 - Q410, Q483	2SC1845
★★	Q657	2SC2878
★★	Q411, Q412	2SC2235
★★	Q481	2SC2238
★★	Q485, Q486	2SK246
★★	Q401 - Q404	2SK369
★	D483, D484	RD6, 2ESB1
★	D401 - D403	1SS131

SWITCH and RELAYS

Mark	Symbol & Description	Part No.
	RY401 Relay	ASR1003
	RY651 - RY656 Relay (REC SELECTOR/ADPTOR SWITCH)	ASR1007
	S401 Remorte Slide switch (PHONO SELECTOR)	ASU1009

COILS and TRANSFORMERS

Mark	Symbol & Description	Part No.
	T401, T402 MC Trans former	ATV1002
	L651, L652 coil(270μH)	ATH1023

CAPACITORES

Mark	Symbol & Description	Part No.
	C643 - C648	CEASO10M50
	C691	CEAS100M25
	C489	CEAS220M25
	C693	CEAS471M16
	C427, C428	CEXANP2RM50
	C421, C422	CEXANP330M50
	C485, C486	CEXA101M25
	C413, C414, C481, C482	CEXA102M25
	C409 - C412	CEYA100M50
	C401, C402, C661, C662	CMA121J500
	C487, C488, C651 - C660	CQPXA271J2A
	C405, C406	CMA820J500
	C415, C416	CQPXA122J2A
	C425, C426, C435, C436	CFTX105J50
	C419, C420	CQPXA124J2A
	C663	CFTXA104J50
	C403, C404	CQPXA152J2A
	C417, C418	CQPXA333J2A
	C423, C424	CQPXA392J2A
	C407, C408	CQPXA681J2A

RESISTORS

Mark	Symbol & Description	Part No.
	R693	RA5S223J
	R694	RA6S223J
	R663 - R692, R697, R698	RDR1/6PU□□□J
	R695	RD1/4PM471J
	R485, R641 - R648	RD1/8PM□□□J
△	R427 - R430	RFA1/4PS330J
△	R487, R488	RSILMF180J
	Other resistors	RDR1/4PM□□□J

OTHERS

Mark	Symbol & Description	Part No.
	6P Pin jack(CD, TUNER, LINE2)	AKB1002
	6P Pin jack(LINE2, TAPE1, PHONO)	AKB1005

PWS Assembly(AWZ1512)

SEMICONDUCTORS

Mark	Symbol & Description	Part No.
△★★	IC601	μPC78M05H
△★★	IC602	μPC7812H
★★	Q602	2SA968
★★	Q601	2SC2238
★★	Q603	2SC2878
△★	D621, D622	RB152
★	D627, D628	RD33EB (HZ33EB)
△★	D601 - D612	11DF2FD
★	D623 - D626	11E2
△★	D613 - D620	3IDF3FC

COIL

Mark	Symbol & Description	Part No.
	L601 Line filter(1mH)	ATF1026

CAPACITORS

Mark	Symbol & Description	Part No.
△	C609 - C613, C626, C627	ACG1005
	Electrolytic	
	C629, C630	CEASOR1M50
	C628	CEAS100M50
	C621	CEAS102M16
△	C615, C616	CEAS470M50
	C624	CEHAQ101M25
	C622, C623	CEHAQ102M16
	C625	CEHAQ221M10
	C603, C604	CEXA102M50
	C601, C602	CEXA222M16
	C605 - C608	CEXA470M50
	C631	CKCYX473M25
	C663	CFTXA104J50

RESISTORS

Mark	Symbol & Description	Part No.
	R609	RD1/4PM102J
△	R601, R602	RS1LMF102J
	Other resistors	RD1/8PM□□□J

DAC/LPF Assembly (AWZ1506)

SEMICONDUCTORS

Mark	Symbol & Description	Part No.
★★	IC305 - IC310	NJM5532D - D
★★	IC301, IC302	PCM56P - K
★★	IC303, IC304	μPC4071C
★★	Q307, Q308	2SA968
★★	Q313 - Q316	2SA970
★★	Q320	2SA992
★★	Q319	2SC1845
★★	Q305, Q306	2SC2238
★★	Q309 - Q312	2SC2240
★★	Q301 - Q304	2SK246
★	D301, D302, D305, D306	AEL - 398

CAPACITORS

Mark	Symbol & Description	Part No.
	C305 - C308, C311 - C315, C318, C333 - C338	CEXA100M50
	C301 - C304, C339 - C342, C347, C348	CEXA101M25
	C345, C346	CEXA221M25
	C351, C352	CEXA471M50
	C316, C317	CEYA100M50
	C355, C356	CMA101J500
	C353, C354	CQSXA221J160

Mark	Symbol & Description	Part No.
	C331,C332	CQPXA103J2A
	C329,C330	CQPXA182J2A
	C319-C328	CQPXA392J2A
	C309,C310	CQSXA102J160

RESISTORS

Mark	Symbol & Description	Part No.
	VR301,VR302 Semi-fixed(100kΩ)	ACP-302
	VR303,VR304 Semi-fixed (20kΩ)	ACP1013
⚠	R358-R361	RS1LMF180J
	R368,R369	RDR1/2PM□□□J
	Other resistor	RDR1/4PM□□□J

COM/TONE Assembly(AWZ1517)

SEMICONDUCTORS

Mark	Symbol & Description	Part No.
★★	IC902	M5220P
★★	IC901	NJM4558DXC
★★	IC801	PD5055
★★	Q805	RN1203 (DTA143ES)
★★	Q802-Q804	RN2201
★★	Q806	RN2203 (DTA124ES)
★★	Q901-Q904	2SC2878
★	D814-D817,D819-D824	AEL1004
★	D826-D838,D840-D842	AEL1056
★	D818,D825,D843	AEL1057
★	D801-D808,D810,D811,D901	1SS131
★	D809	11E2

SWITCH and RELAY

Mark	Symbol & Description	Part No.
★★	S801-S816,S818 Tact Switch	ASG-711
	RY901 Relay	ASR-088

COILS

Mark	Symbol & Description	Part No.
	L801 Inductor(10μH)	LAU100K

CAPACITORS

Mark	Symbol & Description	Part No.
	C813,C814	CCCCH270J50
	C801-C808	CCCSL220J50
	C811,C812,C816	CEANL101M10
	C815,C901,C902,C905,C906	CEAS010M50
	C917,C918	CEAS100M25
	C817	CEAS100M50
	C818-C821,C824,C828,C829	CEAS101M10
	C927,C928	CEXA010M50
	C925,C926,C929-C932	CEXA470M25
	C919,C920	CFTXA104J50
	C822,C823,C834	CEANP330M6

Mark	Symbol & Description	Part No.
	C907,C908	CFTXA153J50
	C913,C914	CFTXA183J50
	C909-C922	CFTXA823J50
	C810	CKCYB103K50
	C809	CKDYB103K50

Mark	Symbol & Description	Part No.
	C827	CKDYF103Z50
	C911,C912	CQPXA332J2A
	C903,C904	CQSA221J50
	C915,C916	CQSA470J50

RESISTORS

Mark	Symbol & Description	Part No.
	VR901 Variable resistor 250kΩx2 (BALANCE)	ACT1027
	VR902,VR903 Variable resistor 100kΩx2 (TONE)	ACT1028
	R836	RA6S223J
	R947-R950	RD1/4PM181J
	Other resistor	RD1/8PM□□□J

OTHERS

Mark	Symbol & Description	Part No.
⚠	Lithium Battery	AEX-008
	X801 Ceramic resonator	ASS-030

SP Terminal Assembly RELAYS

Mark	Symbol & Description	Part No.
	RY101,R102 Relay(SP-A,SP-B)	ASR1002
	RY103 Relay(PHONES)	ASR1003

COILS

Mark	Symbol & Description	Part No.
	L251,L252 AF Choke coil (2.7μH)	ATH1021

CAPACITORS

Mark	Symbol & Description	Part No.
	C251-C254 Mylar capacitor (0.1μF/100V)	ACE-067
	C255-C257	CKDYB103K50
	C261-C264	CQPXA472J2A

RESISTORS

Mark	Symbol & Description	Part No.
	R259-R261	RD1/8PM221J
⚠	R253-R256	RS1LMF□□□J
⚠	R251,R252	RS2LMF100J

OTHERS

Mark	Symbol & Description	Part No.
	Speaker terminal(4P)	AKE1006

Pin Jack Assembly RESISTORS

Mark	Symbol & Description	Part No.
	R501-R508	RDR1/6PU□□□J

CAPACITORS

Mark	Symbol & Description	Part No.
	C501-C508	CQPXA271J2A

OTHERS

Mark	Symbol & Description	Part No.
	Pin Jack(2P)(DAT 1)	AKB-119
	Pin Jack(6P)(ADPT/TAPE2, TAPE1 REC)	AKB1005

HP Assembly CAPACITORS

Mark	Symbol & Description	Part No.
	C832,C833	CKDYB102K50

RESISTORS

Mark	Symbol & Description	Part No.
⚠	R867,R868	RS1LMF181J
⚠	R869,R870	RS2LMF331J

OTHERS

Mark	Symbol & Description	Part No.
	Headphone jack	AKN1002

IND Assembly SEMICONDUCTORS

Mark	Symbol & Description	Part No.
★	D812,D813 LED Assmly	AEL1056
★	D845	1SS131

CAPACITORS

Mark	Symbol & Description	Part No.
	C825,C826	CEAS101M10

RESISTORS

Mark	Symbol & Description	Part No.
	R819,R820	RD1/8PM□□□J

MUTING SW Assembly SEMICONDUCTORS

Mark	Symbol & Description	Part No.
★	D839 LED Assmly	AEL1056

SWITCH

Mark	Symbol & Description	Part No.
★★	S817 Tact Switch(MUTING)	ASG-711

SP SW Assembly CAPACITORS

Mark	Symbol & Description	Part No.
	C830,C831	CEASOR1M50

SWITCH

Mark	Symbol & Description	Part No.
★★	S820 Rotary Switch(SPEAKERS)	ASD1002

DAC3 Assembly SEMICONDUCTORS

Mark	Symbol & Description	Part No.
★★	IC772-IC774	TC74HCU04P

TRANSFORMER

Mark	Symbol & Description	Part No.
	T701,T702 Palus transformer (REC1, REC2)	ATX1003

CAPACITORS

Mark	Symbol & Description	Part No.
	C770-C775	CEAS010M50
	C769	CEAS101M10
	C705	CEAS471M10
	C776-C781	CKDYB102K50
	C702,C706,C782	CKDYB103K50
	C747,C796	CKDYF103Z50

RESISTORS

Mark	Symbol & Description	Part No.
	R770-R783,R785,R786	RD1/8PM□□□J

OTHERS

Mark	Symbol & Description	Part No.
	Pin Jack(3P)(DIG2,DIG3,PLAY1, PLAY2,REC1,REC2)	AKB1032

LINE FILTER Assembly COIL

Mark	Symbol & Description	Part No.
⚠	L641 Line Filter	ATF1006

OTHERS

Mark	Symbol & Description	Part No.
⚠	C641,C642 Electrolytic capacitor (0.01μF/125V)	ACG1003

JAMPPAR CONNECT Assembly

There are no supply parts.

NOTE: The encircled numbers denote measuring points in the circuit and pattern diagrams.

WAVE FORMS

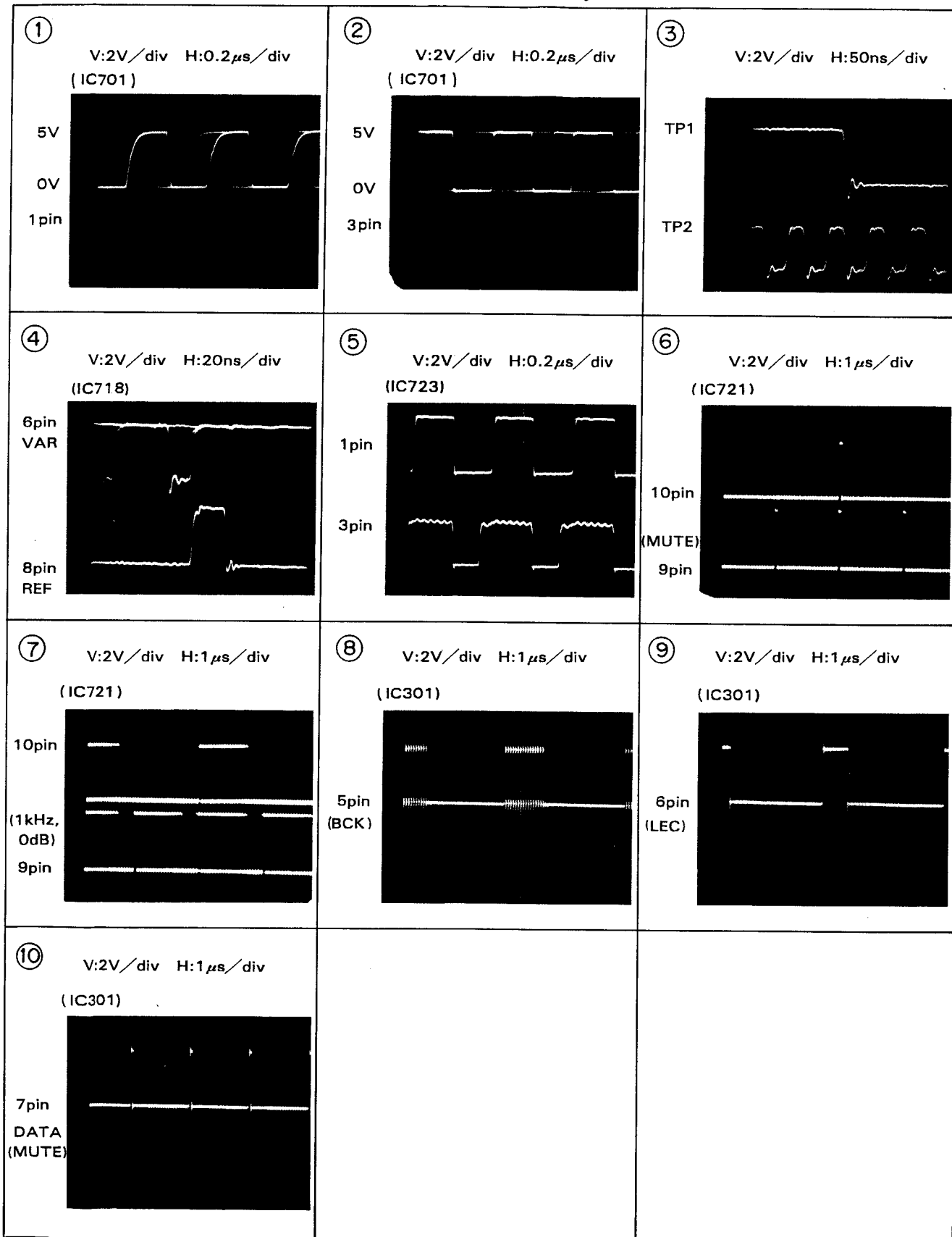

10. CIRCUIT DESCRIPTIONS

Refer to the photo on page 51.

General Description of Digital Circuits

1. Optical Transmission-Receiving Connector Section

This section consists of a receiving connector, which converts optical signals passing through an optical fiber to electrical signals (signals at the Complementary Metal-Oxide Semiconductor (CMOS) logic level), and a transmission connector, which converts electrical signals to optical signals.

2. I/O Circuit Section

The I/O circuit is divided into the following two sections: an input section (DIGITAL 2, DIGITAL 3, DAT 1 - IN/PLAY, DIGITAL ADPT/DAT 2 - IN/PLAY) consisting of an inverter buffer for amplifying signals which are input at 0.5 V_{p-p} up to the CMOS level, an inverter buffer for forming waves, and an output section (DAT 1 - OUT/REC, DIGITAL ADPT/DAT 2 - OUT/REC) for converting CMOS level signals to 0.5 V_{p-p} using a pulse transformer. DAT 1 - IN/PLAY and DIGITAL 3 circuits do not have connectors for receiving optical signals, input terminals in stead, connector on is made by inserting a pin-jack to open the pin-jack SW (when the pin-jack is inserted, the SW is opened and priority is given to input).

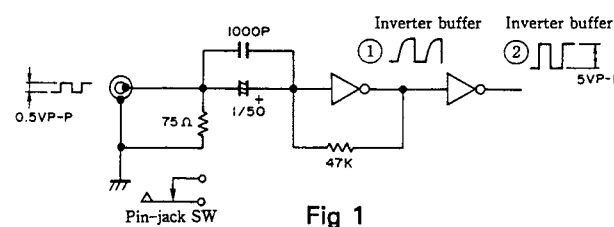

4. Distortion Optical Transmission Compensating Circuit

This circuit compensates for the distortion in signal pulse width (pulse duty distortion) caused by optical transmission. Due to the adoption of a biphas modulation system for the digital audio interface format, the periods during which a signal is "H" (5 V) and "L" (0 V) must be equalized; the duty ratio is 50%. During optical transmission in particular, the distortion of pulse width causes differences in the "H-L" ratio. This circuit compensates for such a difference so that the signal pulse has a duty ratio of 50%.

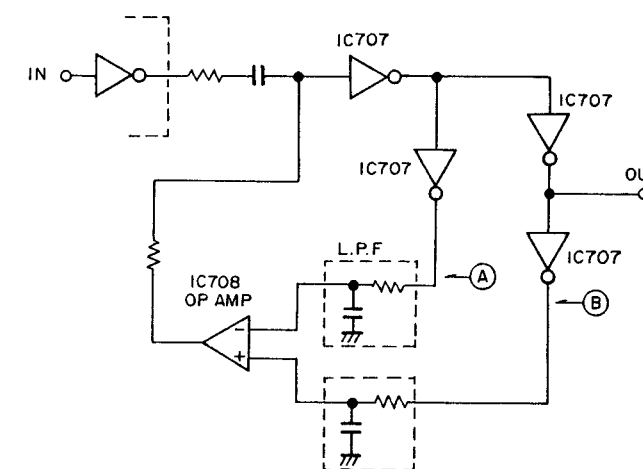

Fig 2 Optical Transmission Compensating Circuit

FEEDBACK the difference between the reverse phase A and the nonreverse phase B of the biphas signal is feedback so that the output of the direct current is made equal to 0 (duty ratio of 50%).

3. I/O Logic Section

The I/O logic section, consisting of CMOS logic ICs from the 74 HC series, is used to changeover input functions, REC selection and switching the DIGITAL ADPT ON/OFF. Digital audio interface format signals (Photo 6, 7), which are input from the optical transmission-receiving connector section and the I/O circuit section, are transmitted at the CMOS level (0 V - 5 V). Switching signals control each IC through serial-parallel conversion of the IC712 (PD0012) serial signals transmitted from the IC801 (PD5055) system control micro computer. For example, when the function button DIGITAL 1 is pressed, the signals are converted as follows: pin No. 5 of IC701 → H (5V), pin No. 12 of IC703 → L (0V), pin No. 1 of IC705 → L (0V) and pin No.10 of IC701 → L (0V).

- Wave changes due to distortion caused by optical transmission

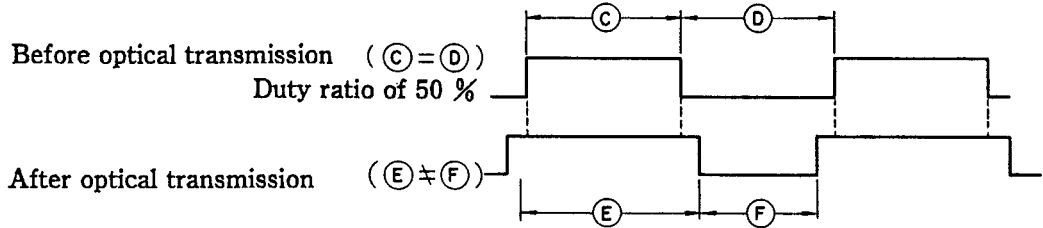

Fig 3

- Biphase Modulation System

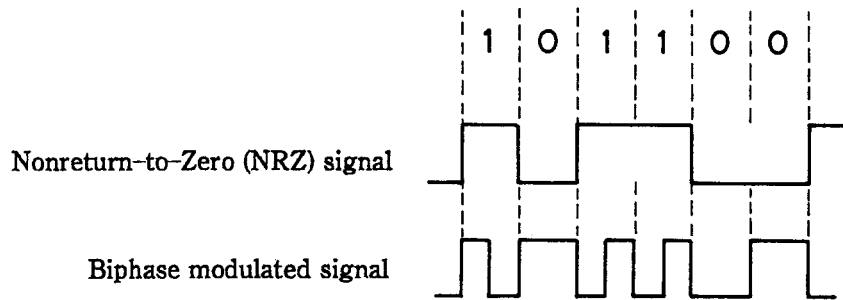

Fig 4 Biphase Modulated Signal

For normal digital signals (NRZ signals), a high level is indicated by the value "1" (5 V at the CMOS level) and a low level by the value "0" (0V at the CMOS level). In biphase modulation, these levels are indicated by the intervals between pulse reversals, as shown in Fig 4. Therefore, even when a value of "0" is continuously output (when no signals are transmitted), digital output goes through a repeated high-low sequence.

5. Data Demodulation and PLL 1

Phase-Locked Loop 1 (PLL 1) demodulates all data transmitted through the digital audio interface (biphase modulation system) into Nonreturn-to-Zero (NRZ) signals and outputs LRCK, WCK, DATA, BCK, etc.

In addition, PLL 1 is used for separating the IC718 (CXD1076P) clock signal ($256 \times F_s$) from the input signals. (F_s ... sampling frequency; 44.1 kHz in the case of CD).

PLL 1 is operated through VAR (pin No. 6) and REF (pin No. 8) output from IC718, the relationship of which is shown in Photo ④.

In addition, PLL 1 requires adjustment of the VAR current (VR702) and VCO oscillation frequency range (VR703). These adjustments are carried out to ensure the PLL 1 lock status (VR702) and to keep operation within the required F_s range (32 kHz - 48 kHz).

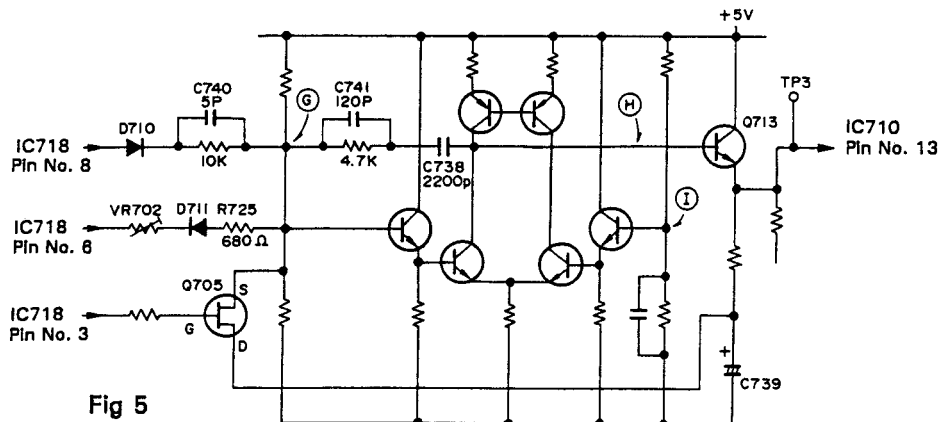

Fig 5

Although the circuit shown in Figure 5 appears complicated, it can be simplified by constructing the L.P.F, as shown in Figure 6, (phase comparison is carried out in IC718).

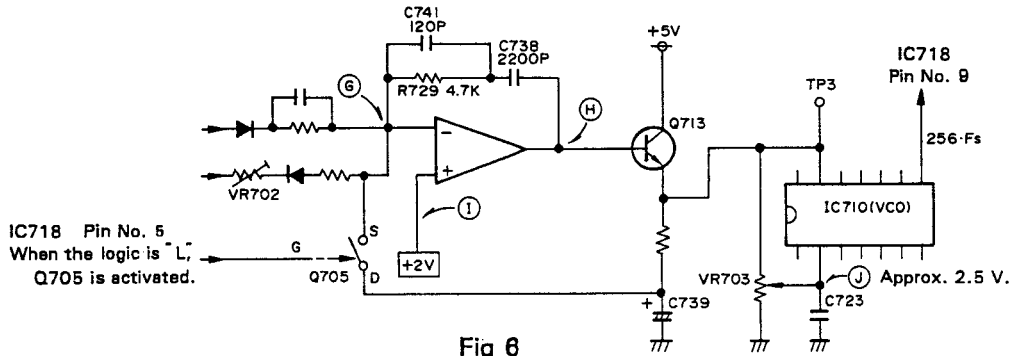

Fig 6

Q705

Q705 is used for relocking the PLL when it becomes unlocked. When no signals are input or when signals which cannot lock PLL are input, TP3 voltage increases to approximately +4 V, disabling the relocking of the PLL.

To prevent this, when the PLL is released from the locked status, IC718 pin No.13 (unlock terminal) becomes "H" and D 701 is switched off (the D 702

cathode side also becomes "H"), activating the oscillation circuit.

The output signal of the oscillation circuit which is input to the IC718 CS terminal is output to the DISCHG terminal at a demultiplied Frequency. Q705 is activated by this output signal and reduces TP3 voltage once, causing relocking to be enabled.

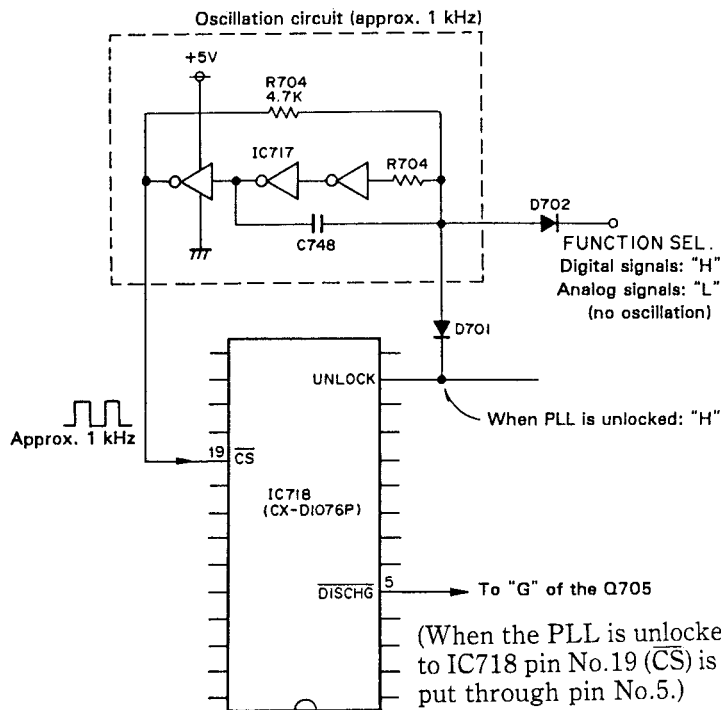

Fig 7

VR703

The output frequency (pin No. 8) of the VCO, or IC710 (SN74LS624N) of PLL 1, is determined by pin No. 13 (TP3) voltage.

In the digital circuits described here, TP3 voltage can only be changed from 1 V to 4 V. Thus, TP2 frequency must lie within this range.

As observed in Figure 8 showing the V-F characteristic, changing the voltage at point ① (pin No. 2 of IC710) causes the VCO, V-F characteristic which determines the relationship between TP3 voltage and TP2 frequency, to change back and forth. Adjusting this V-F characteristic with VR 703 to the best position located in the center of the drawing is called "Range Adjustment".

The voltage at point ① varies slightly according to IC710 dispersion. VR703 must be adjusted in accordance with the prescribed procedure.

Note:

- . TP2 frequency is $256 \times F_s$.
- . The voltage at point ① serves as a reference value.

6. PLL 2

PLL 2 generates a frequency of $384 F_s$ (a frequency 384 times as great as the sampling frequency) necessary for the digital filter IC and IC712 (YM3404B), by amplifying the BCK signal ($32 \cdot F_s$), which is input from IC718, by 12 times. PLL2 has a large L.P.F. time constant in order to completely suppress the occurrence of jitters.

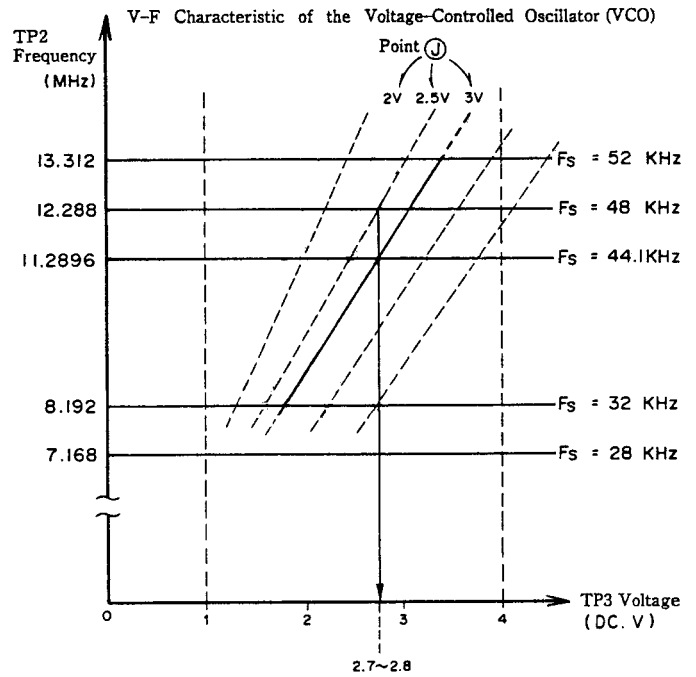
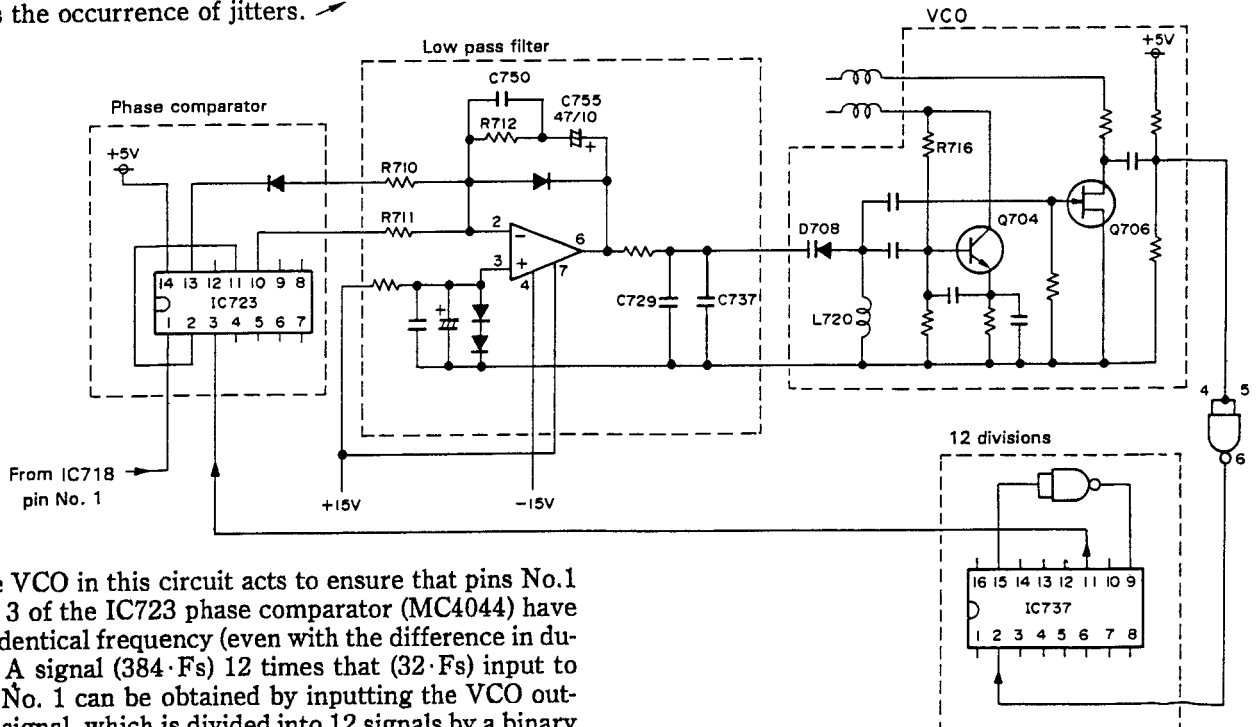

Fig 8

Furthermore, L720, D708, C729, C737 and C755 are fixed with hot-melting adhesive to improve sound quality.

When PLL 2 is operating normally, the trailing edge of IC723 pin No.1 coincides with that of IC723 pin No.3 (Photo 5).



The VCO in this circuit acts to ensure that pins No.1 and 3 of the IC723 phase comparator (MC4044) have an identical frequency (even with the difference in duty). A signal ($384 \cdot F_s$) 12 times that ($32 \cdot F_s$) input to pin No. 1 can be obtained by inputting the VCO output signal, which is divided into 12 signals by a binary counter, to pin No. 3 of the phase comparator.

7. Digital Filter

Digital filtering is carried out in the 4x over-sampling digital filter or IC721 (YM3404B). This IC carries out 4x oversampling of those signals which are input to IC721, including the DATA, LRCK and BCK signals from IC718 (CXD1076P), and the 384·Fs signal from PLL2 (Photos ⑥ and ⑦).

8. Digital Muting and Timer Circuit

This circuit is used for muting data when PLL1 is unlocked (pin No. 13 of the IC718 UNLOCK terminal → High).

IC720 prevents muting from being immediately released (muting is held for 1.3 seconds) when the UNLOCK terminal changes from "Hi to Lo". It also prevents noise caused by unstable circuits immediately following the release of the UNLOCK status.

9. D/A Conversion Section

D/A conversion is carried out in the D/A converting IC and the PCM56P-K (IC301 and IC302). The following digital signals are input to the relevant pins of IC301 and IC302: serial data to pin No. 7 (Din), data shift clock signals to pin No. 5 (BCK) and latch-enable control to pin No.6 (LEC) (Photos ⑧, ⑨ and ⑩). Analog signals are output from pin No. 13, a current output terminal. However, since pin No. 13 is a virtual grounding point for the I/V conversion buffer amplifier, it has a voltage of zero. Therefore, its wave form cannot be observed with an oscilloscope.

Dispersion compensation of the MSB-bit current minimizes signal distortion by adjusting VR 301 and VR 302, which are used for MSB adjustment.

10. I/V Conversion Buffer Amplifier

To improve sound quality, the output current from the D/A converter comes from pin No. 13, a current output terminal, of IC301 and IC302. The I/V conversion buffer amplifier is used to convert this current output to voltage output. A current of $\pm 1\text{mA}$ ($\pm 30\%$) output from pin No. 13 has a large dispersion and requires level adjustment (VR 303).

11. Frequency Dependent Negative Resistance (FDNR) Low Pass Filter

Since only band signals with an "fc" (cut-off frequency) of 30 kHz pass through the resistance of the fifth butterworth-type analog low pass filter, the operation amplifier is affected by less noise and distortion.

This filter circuit allows frequencies equal to or exceeding the fc (30 kHz) to flow to the FDNR.

12. Buffer and De-Emphasis Circuit

This circuit consists of a buffer amplifier, which receives high-impedance signals from the low pass filter circuit, and a de-emphasis circuit which uses IC309.

The CD software is divided into two types, one of which is pre-emphasized and one which is not. The de-emphasis circuit releases software from being pre-emphasized.

Data determining software pre-emphasis is contained in the digital interface format signal. IC718 (CXD1076P) reads this data and indicates whether pre-emphasis is specified or not according to the "H or L" voltage of IC718 pin No.25.

H: Pre-emphasized software An output signal which has passed the de-emphasis circuit is selected by the function selector circuit (RY553 of the relay is switched on).

L: Non pre-emphasized software An output signal which has not passed the de-emphasis circuit is selected by the function selector circuit (RY554 of the relay is switched on).

11. IC INFORMATION

CXD1076P

Terminal arrangement

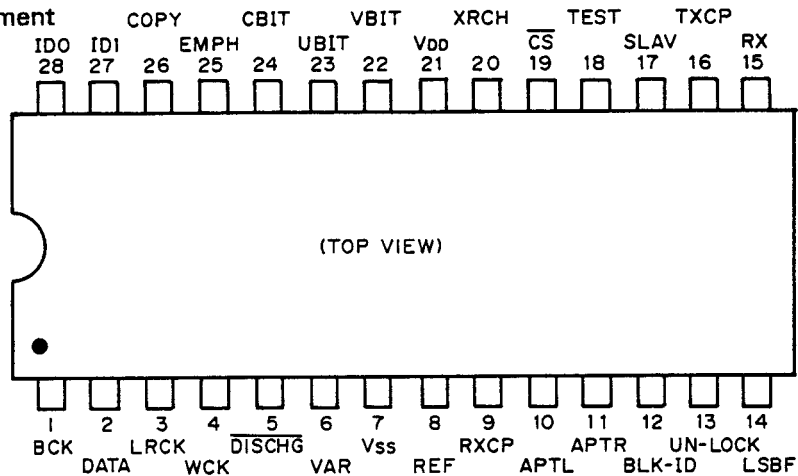

Operation

● Digital Audio Data

(When the LSBF terminal is set at "H" and the XRCH terminal is set at "L")

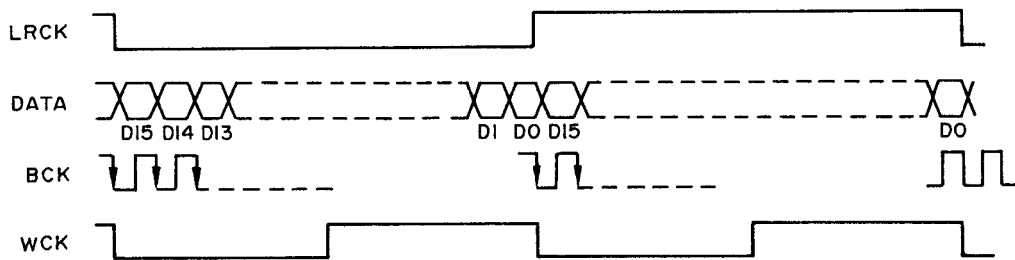

Assuming D/A converter connection, the LRCK, DATA, BCK and WCK signals are output at the intervals shown in the figure above. Digital Audio Data (DATA output) is output after being shifted at the BCK negative edge. When the LSBF terminal is set at "Low", data is output to the MSB first. When it is set at "High", data is output to the LSB first. In addition, LRCK polarity can be changed with the XRCH terminal. When the XRCH terminal is set at "Low", the "Low" status of the LRCK terminal indicates L-ch data output.

• Channel Status Data

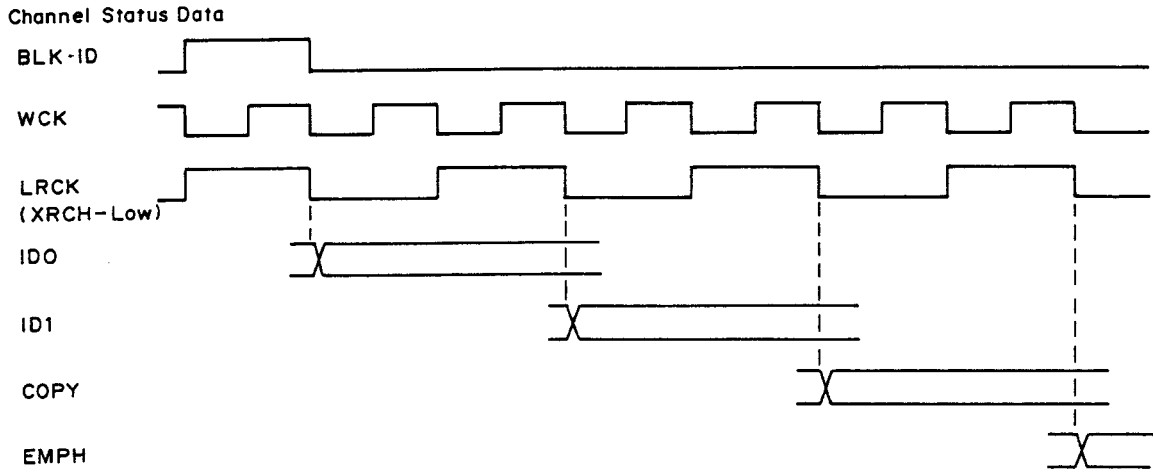

The ID0, ID1, COPY-inhibit and emphasized data contained in the Channel Status Data are output to the ID0, ID1, COPY and EMPH terminals respectively, at the intervals shown in the figure above.

• User Definable Data, Validity Flag

User Definable Data, Validity Flag

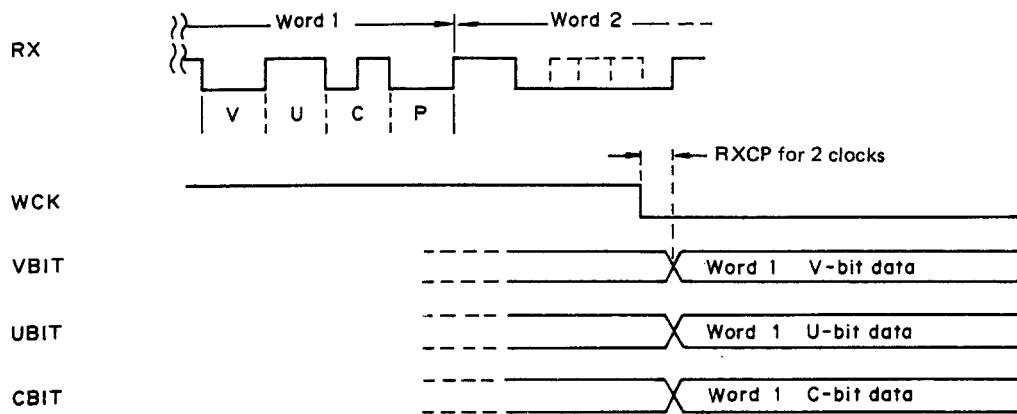

Digital I/O User-Defined Data and the Validity Flag which have been transmitted to the RX terminal in the Digital Interface Format are output to the UBIT and VBIT terminals respectively, shortly after WCK trailing. C-bit data is also output to the CBIT terminal.

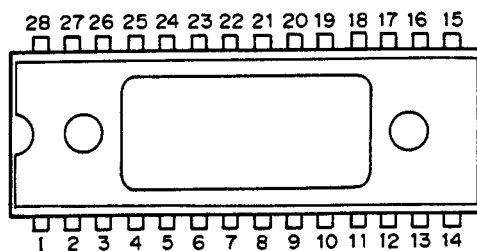

Terminals description

Terminals Number	I/O	Terminal identification	Terminal description
1	O	BCK	Digital audio data shift clock output.
2	O	DATA	Demodulated digital audio data serial output.
3	O	LRCK	Pulse output for identifying left and right audio data channels. Channel polarity can be changed with the XRCH terminal. When the XRCH terminal is set at "L", the right channel is set at "High".
4	O	WCK	Pulse output with a frequency twice as great as the LRCK pulse. The trailing edge of this pulse indicates the end of a word.
5	O	$\overline{\text{DISCHG}}$	Low-active pulse output which causes locking of the external PLL used for clock extraction.
6	O	VAR	Low-active pulse output for determining the sink current of the external PLL.
7	—	V _{SS}	GND terminal.
8	O	RFF	High-active pulse output for determining the external PLL source current.
9	I	RXCP	Clock input with a frequency 256 times as the source frequency extracted by the external PLL.
10	O	APTL	Pulse output for aperture adjustment.
11	O	APTR	Pulse output for aperture adjustment.
12	O	BLK-ID	BLOCK detection pulse output for synchronizing the beginnings of the C-bit BLOCK.
13	O	UNLOCK	Lock status detection output for the external PLL. When this terminal is set at "L", the external PLL is locked.
14	I	LSBF	Input terminal for switching between the "High" and "Low" modes for audio data at the beginning of serial output. "H" : LSB first "L" : MSB first
15	I	RX	Digital I/O data input which has been demodulated using the digital audio interface format.
16	O	TXCP	128 fs clock output for use as the external equipment master clock.
17	I	SLAV	Terminal which allows the TXCP, WCK, LRCK and BCK data output terminals to be set in the "Hi-z" mode. "L" : Normal mode "H" : Hi-z mode
18	I	TEST	Input terminal for switching between the TEST and NORMAL modes. "H" : TEST mode "L" : NORMAL mode
19	I	$\overline{\text{CS}}$	Clock input for creating the $\overline{\text{DISCHG}}$ signal required by the external PLL.
20	I	XRCH	Input terminal for determining LR clock polarity.
21	—	V _{DD}	Power terminal.
22	O	VBIT	Validity Flag (V-bit) output terminal.
23	O	UBIT	User-Defined Data (U-bit) output terminal.
24	O	CBIT	Channel Status Data (C-bit) output terminal.
25	O	EMPH	Emphasized data output terminal. "H" indicates active status.
26	O	COPY	Output terminal for COPY-inhibit data. "L" indicates inhibiting mode.
27	O	ID1	ID1 output terminal.
28	O	ID0	ID0 output terminal.

•CXD 1076P Timing Chart

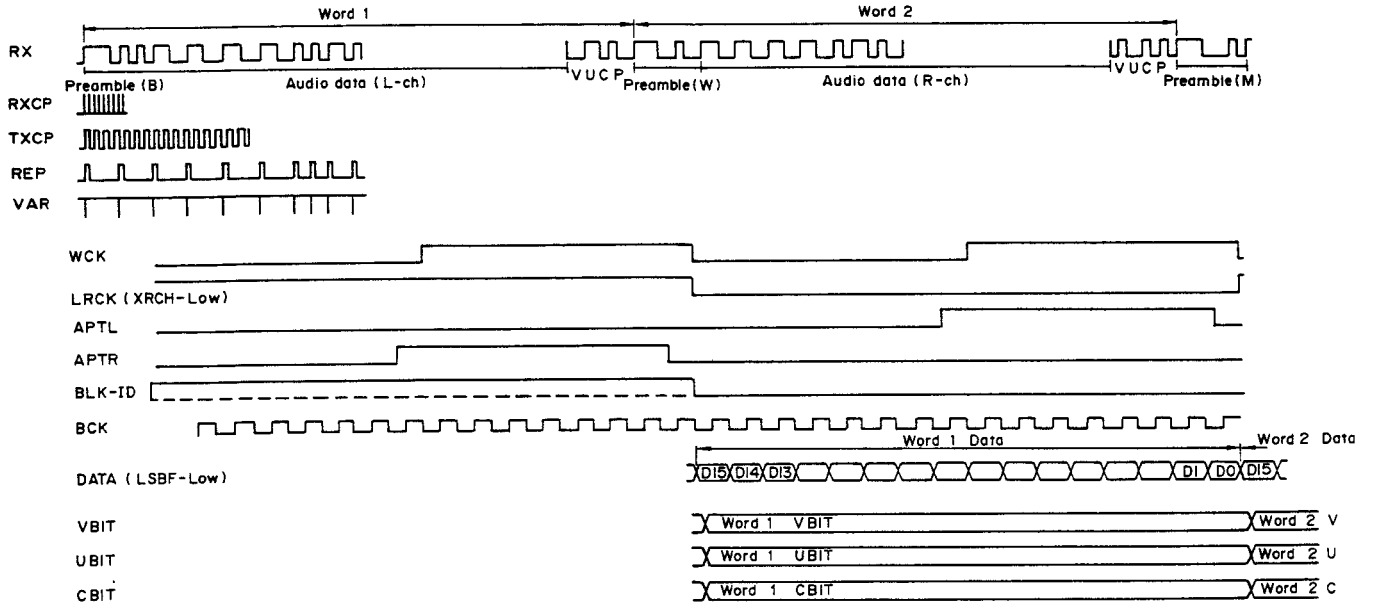

SN74LS624N

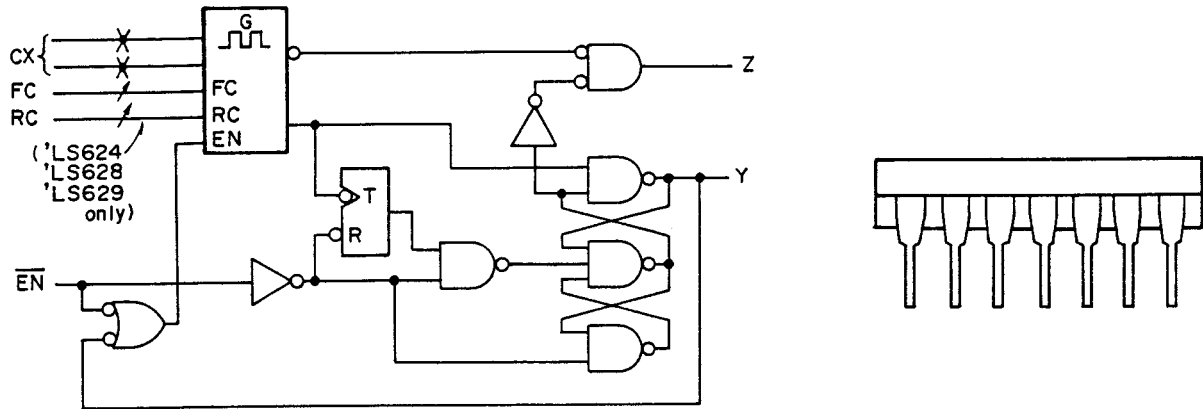

YM3404B

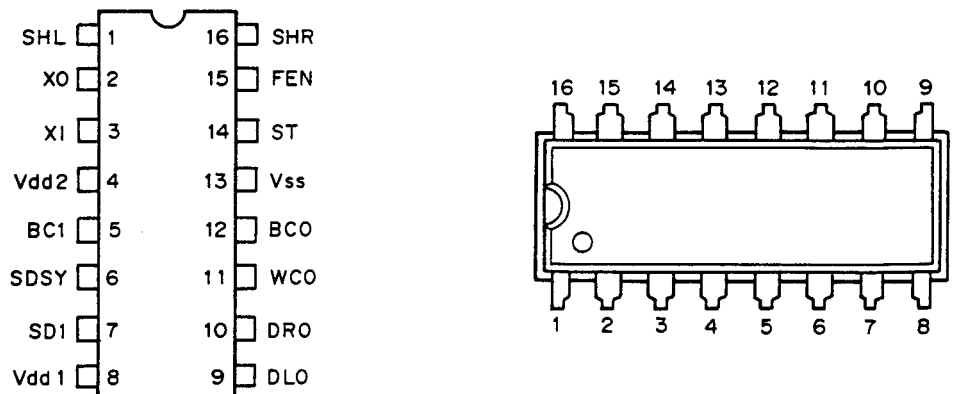

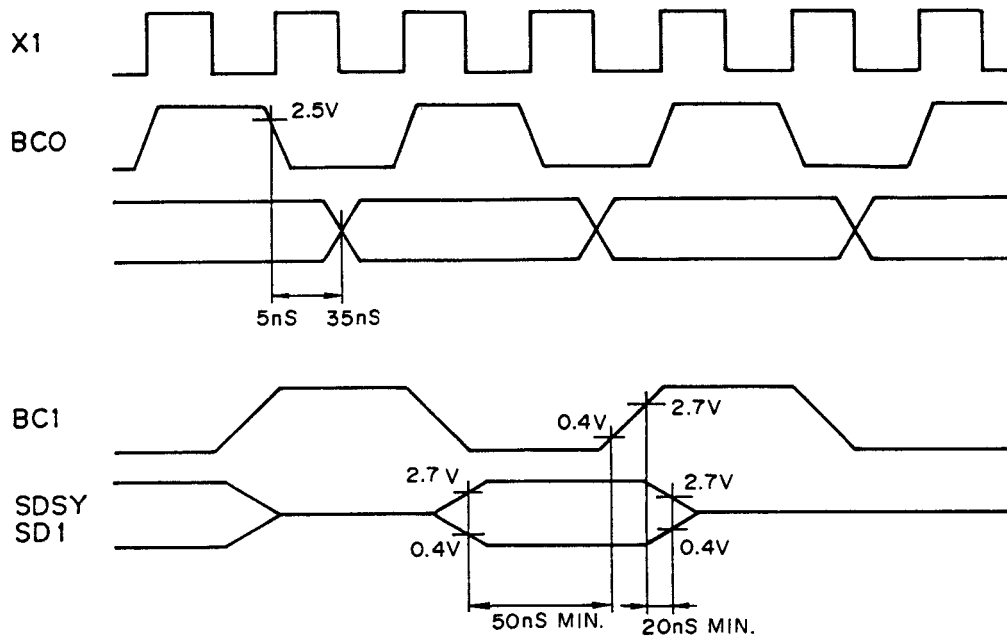

PCM56P

PIN No.		PIN No.	
1.	-Vcc	16.	+Vcc
2.	DIG GND	15.	VPOT
3.	+VL	14.	MSB ADJ
4.	N C	13.	I out
5.	CK	12.	ANA GND
6.	LEC	11.	S.J
7.	DATA	10.	RF
8.	-VL	9.	V out
			Positive logical power supply
			Potentiometer terminal
			MSB adjustment terminal
			Current output
			Analog grounding
			Summing junction (operation amplifier input)
			Feedback resistance
			Voltage output

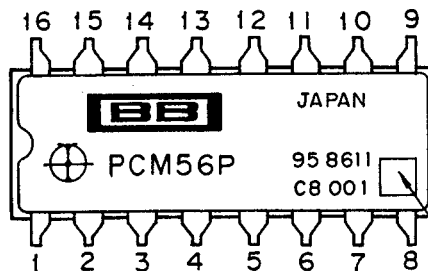

Grading
 Mark "J" for a "J" grading and
 "K" for a "K" grading.
 No mark for a "P" grading.

A-91D

SN74ALS163BN

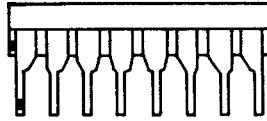

Internal Circuit Diagram

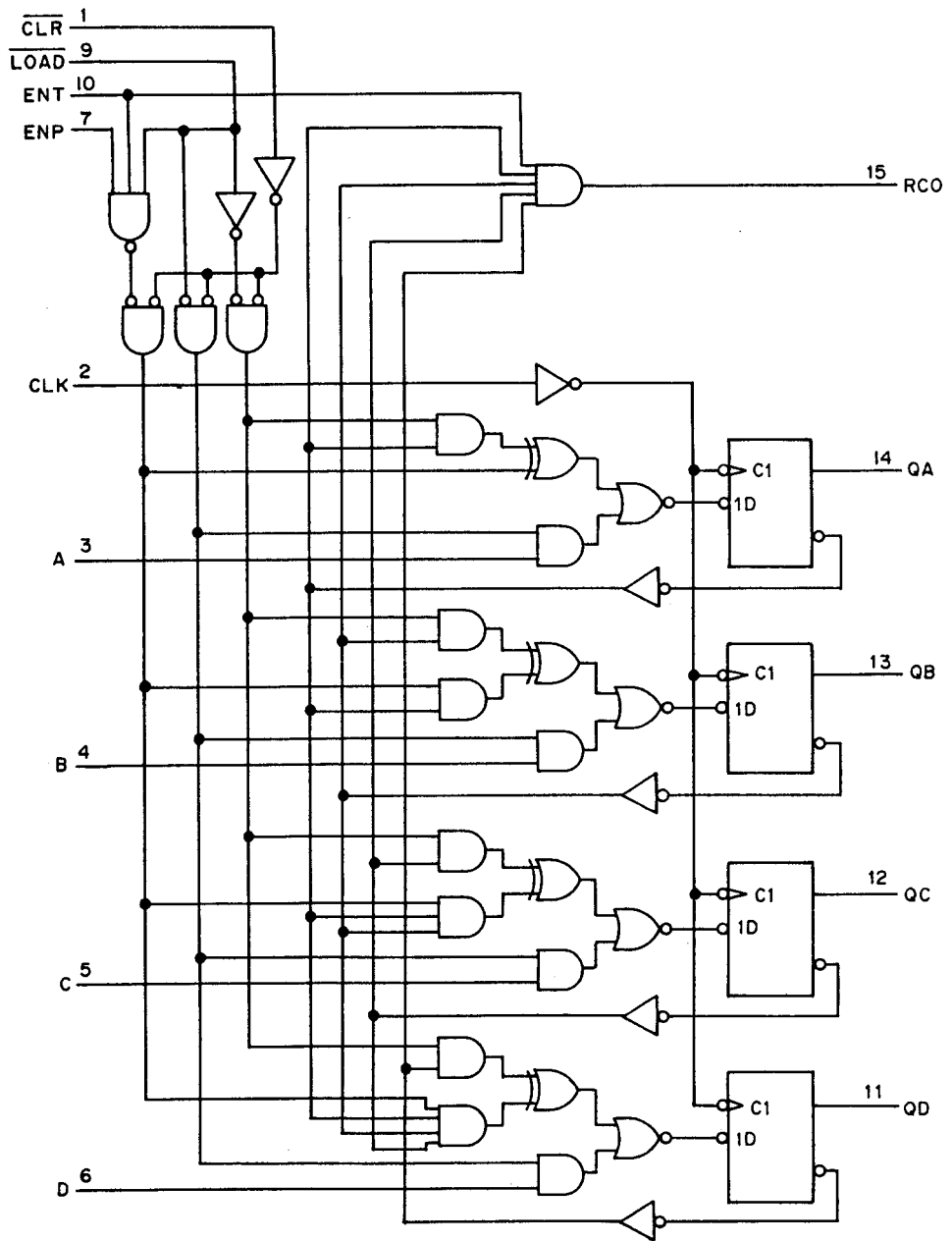

12. ADJUSTMENTS

1. PLL Adjustment

Purpose: To secure a range of fs 32kHz to fs 48kHz.
 Sign of poor adjustment: No sound.(PLL is not locked.)

Measuring instrument and jig	Measuring instrument connection point	Adjustment location
Oscilloscope Digital signal generator (e.g. CD player with digital output)	CH1:TP1 (2V/div,20ns/div) CH2:TP2 (2V/div,20ns/div)	VR702
	CH1:TP3 (0.5V/div,20ns/div)	VR703

Adjustment procedure

1. Input the 44.1 kHz sampling frequency digital signal (0) into the digital input terminal
2. Assume that VR703 is the mechanical center.
3. Adjust VR702 so that the trailing edges of the TP1 and TP2 output signal waveforms correspond to one another (see Photo 12-2).
4. Adjust VR703 so that TP3 voltage will be 2.7V-2.8V.

Adjustment diagram

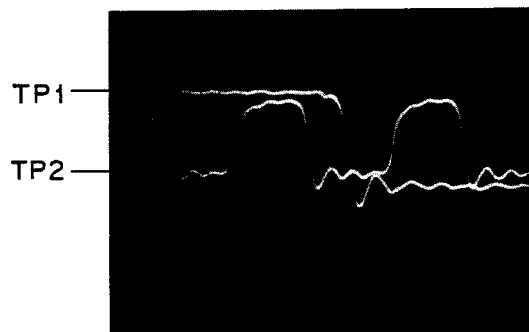
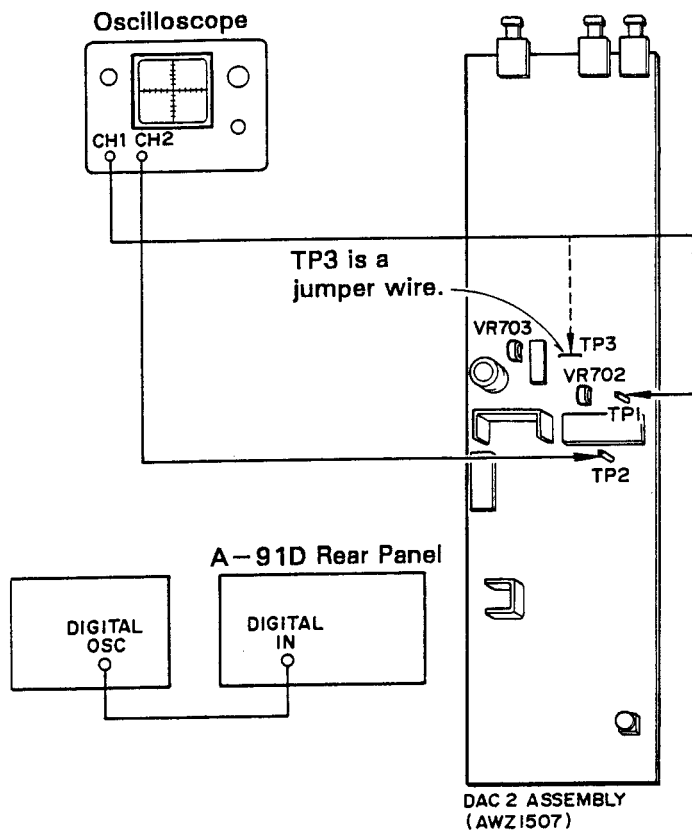

Photo 12-1
Fail condition of PLL Adjustment

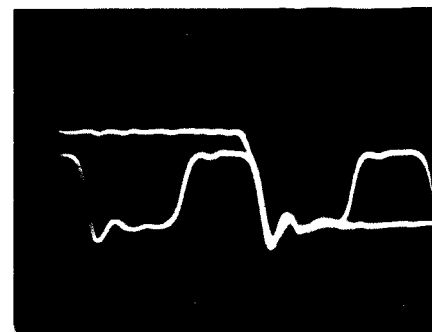

Photo 12-2
Proper condition of PLL adjustment.

2.MSB Adjustment

Purpose: To correct dispersion of the MBS bit current and minimize distortion.
 Sign of poor adjustment: Distortion increases.

Measuring instrument and jig	Measuring instrument connection point	Adjustment location
Oscilloscope (one that can measure 30MHz or more) Instrument for measuring distortion (with an accuracy of with in 0.01 %) AC Voltmeter	CN557 Pin No.7 (R CH) Pin No.9 (L CH) Note: Be sure to connect CN557 prior to adjustment.	VR301, VR303 VR302, VR304

Adjustment procedure

1. Input the 1kHz and 0dB digital data into the digital input terminal (e.g.: a CD player with a digital output terminal and the YEDS-7 test disc).
2. Adjust the VR303 and VR304 so that the output signals from terminals (5) and (6) of CN557 will be $2V \pm 0.1V$.
3. In the same way, adjust VR301 and VR302 so that distortion of the output signals from terminals (5) and (6) of CN557 will be 0.005 % or less (see Photo 12-3).

Adjustment diagram

Input

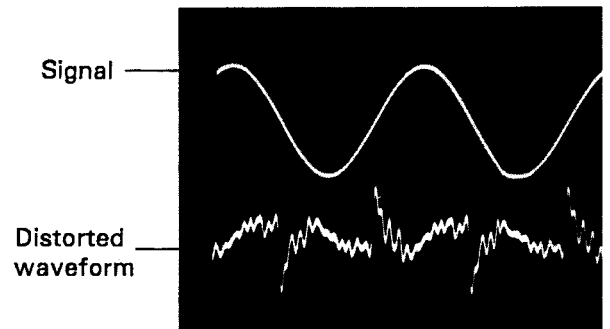
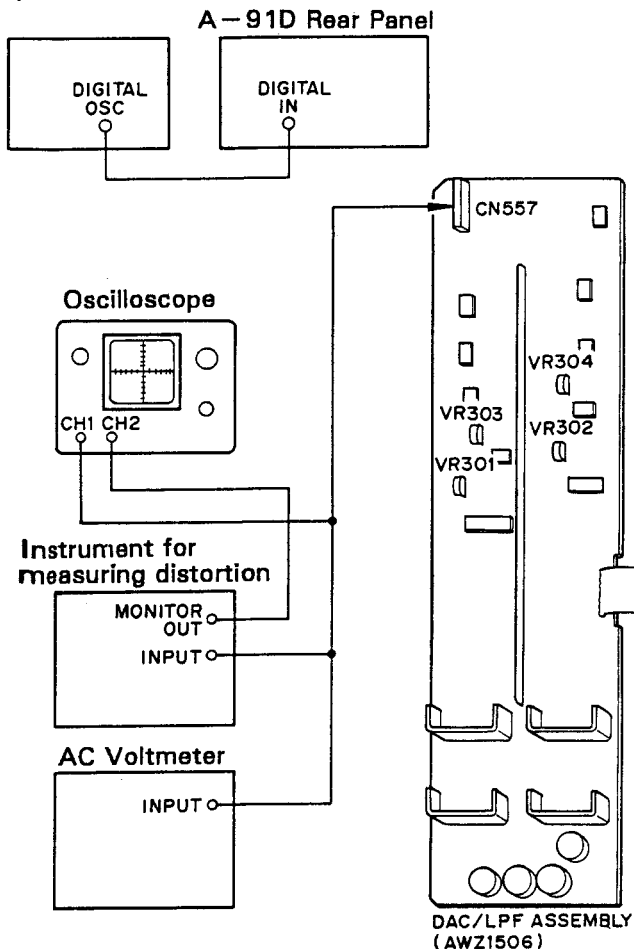

Photo 12-3

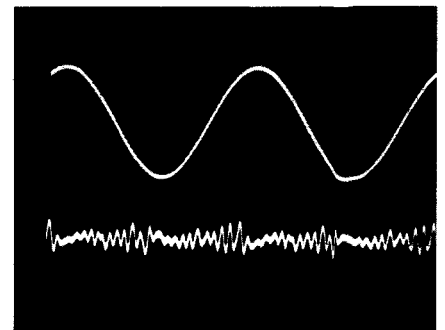

Photo 12-4 2V/div
0.2µm sec/div

* The Siba-Soku 725 is used to measure distortion (range of 0.01%) and a 30 kHz LPF is activated.

12. RÉGLAGES

1. Ajustement PLL

But: Pour fixer une gamme de 32kHz à fs 48kHz.
 Signe de mauvais ajustement: Pas de son. (PLL n'est pas verrouillé)

Instrument de mesure et calibre	Point de connexion d'instrument de mesure	Emplacement de l'ajustement
Oscilloscope Générateur de signaux numériques (ex.: lecteur de disque compact à sortie numérique.	CH1:TP1 (2V/div, 20ns/div) CH2:TP2 (2V/div, 20ns/div)	VR702
	CH1:TP3 (0.5V/div, 20ns/div)	VR703

Procédure d'ajustement

1. Entrer le signal numérique de fréquence d'échantillonnage de 44.1 kHz (0) dans la borne d'entrée numérique.
2. Prendre le VR703 comme centre mécanique.
3. Ajuster le VR702 de manière à ce que les rebords arrière des formes d'onde de signal de TP1 et TP2 correspondent entre eux (voir la photo 12-2).
4. Ajuster le VF703 de manière à ce que la tension de TP3 soit de 2,7V-2,8V.

Diagramme d'ajustement

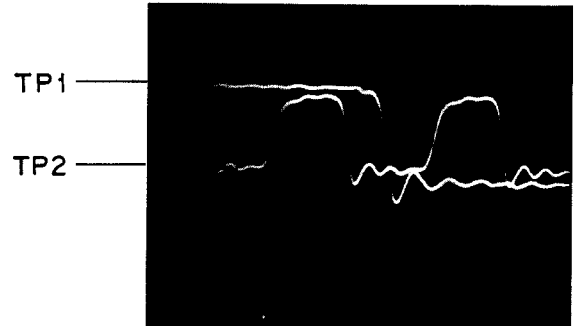
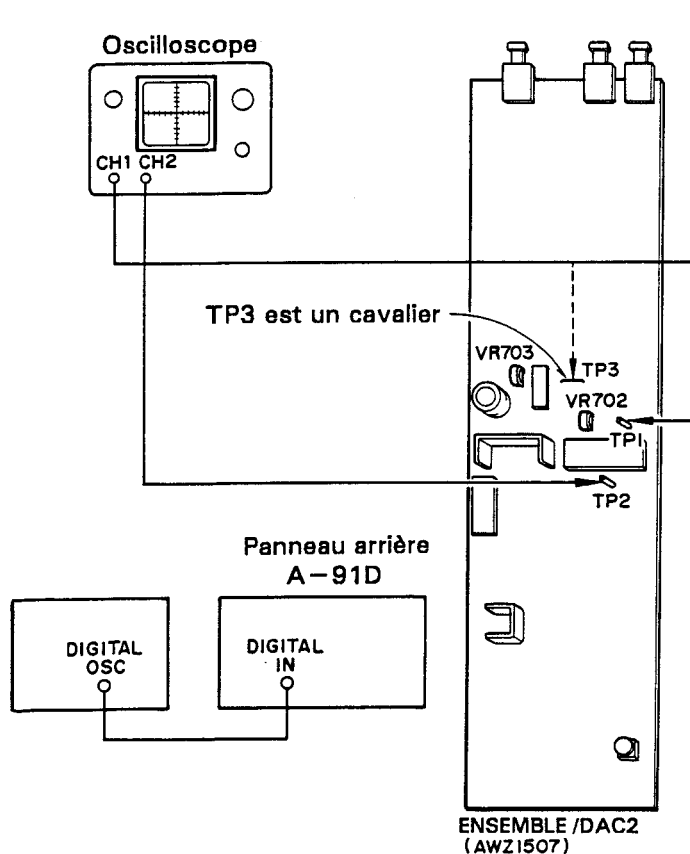

Photo12-1 : mauvais réglage de PLL

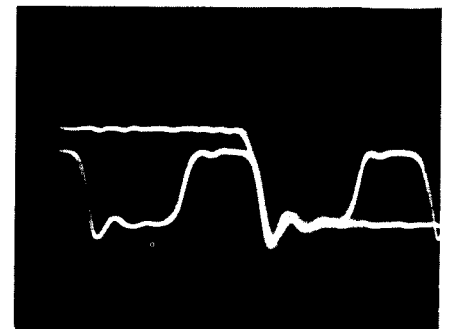

Photo12-2 : bon réglage de PLL

Ajustement de MSB

But: Pour corriger la dispersion du courant de bit de MBS et pour minimiser la distorsion.
Signe de mauvais ajustement: Augmentation de distorsion.

Instrument de mesure et calibre	Point de connexion d' instrument de mesure	Emplacement de l'ajustement
Oscilloscope (modèle pouvant mesurer 30 MHz ou plus) Instrument pour la mesure de la distorsion (avec une précision de 0.01 %) Voltmètre CA	CN557 Broche N° 7 (Canal D) Broche N° 9 (Canal G) Note: Toujours connecter le CN557 avant de procéder à l'ajustement.	VR301, VR303 VR302, VR304

Procédure d'ajustement

1. Entrer les données numériques de 1 kHz et 0 dB dans la borne d'entrée numérique (p.e. : un lecteur de CD ayant une borne de sortie numérique ou le disc d'essai YEDS-7).
2. Ajuster les VR303 et VR304 de manière à ce que les signaux de sortie des bornes (5) et (6) de CN557 soit de 2V ± 0,1V.
3. De la même manière, ajuster les VR301 et VR302 de manière à ce que la distorsion des signaux de sortie des bornes (5) et (6) de CN557 soit de 0,005 % ou moins (voir la Photo 12-3).

Diagramme d'ajustement

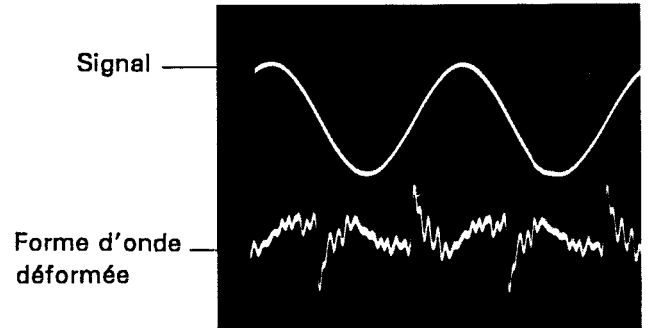
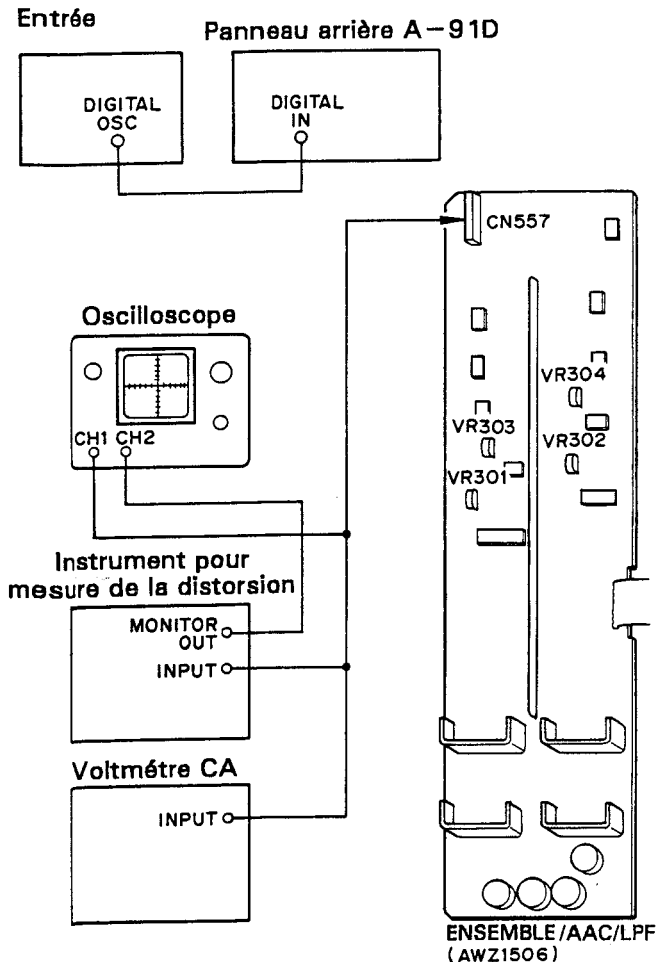

Photo 12-3

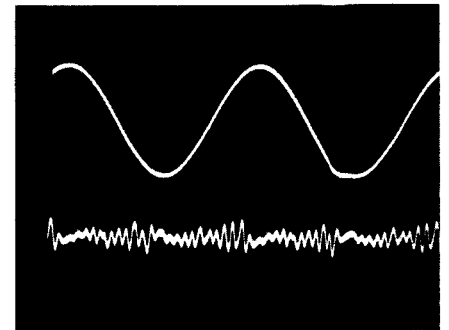

Photo 12-4

2V/div
0.2m sec/div

* Le Shiba-Soku 725 plage nécessaire : 0,0 1% est utilisé pour mesurer la distorsion et un LPF de 30 kHz est activé.

12. AJUSTES

1. Ajuste de PLL

Propósito: Fijar un margen de fs 32kHz a fs 48kHz.
 Signo de mal ajuste: Sin sonido.(PLL sin enclavar.)

Medidor y plantilla	Punto de conexión del medidor	Situación de ajuste
Osciloscopio Generator de senal digital (ej.:Reproductor de discos compac- tos con salida digital)	CH1:TP1 (2V/div, 20ns/div) CH2:TP2 (2V/div, 20ns/div)	VR702
	CH1:TP3 (0.5V0/div, 20ns/div)	VR703

Procedimiento de ajuste

1. Introduzca la señal digital de frecuencia de muestreo de 44,1 kHz (0) en el terminal de entrada digital.
2. Asuma el VR703 como el centro mecánico.
3. Ajuste VR702 de modo que los bordes posteriorese de las forma de onda de las señales de salida de TP1 y TP2correspondan entre sí (Consulte la foto 12-1).
4. Ajuste VR703 de modo que la tensión de TP3 sea de 2,7V a 2,8V.

Diagrama de ajuste



Foto 12-1
Ajuste inadecuado de PLL



Foto 12-2
Ajuste adecuado de PLL

Ajuste de MSB

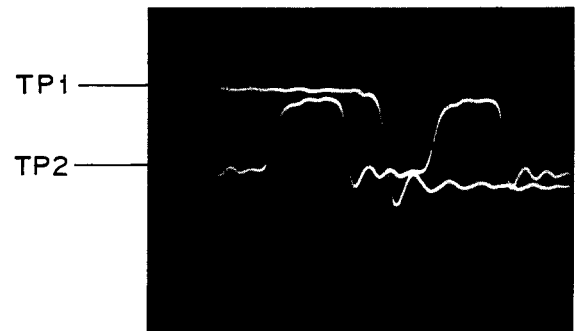
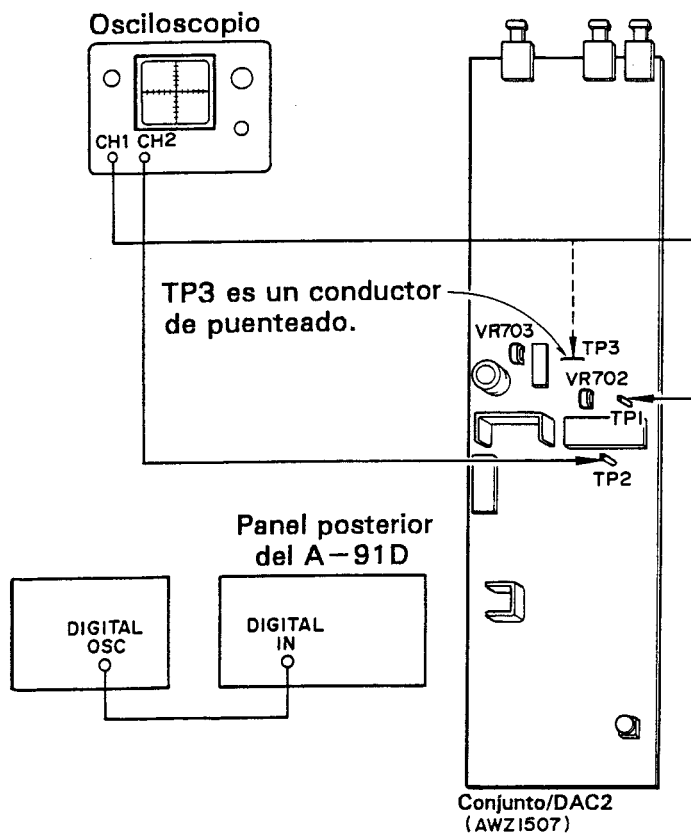
Propósito: Corregir la dispersión de la corriente de MSB y minimizar la distorsión.
 Signo de mal ajuste: Aumento de la distorsión.

Medidor y plantilla	Punto de conexión del medidor	Situación de ajuste
Osciloscopio (uno que pueda medir 30 MHz o más) instrumento para medir la distorsión (con una precisión de dentro de 0,01%) Voltímetro de CA	CN557 Patilla n.º 7 [canal derecho (R)] Patilla n.º 9 [canal izquierdo (L)] Nota: Cerciórese de conectar el CN557 antes del ajuste.	VR301, VR303 VR302, VR304

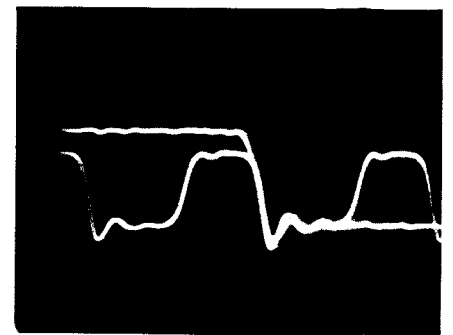
Procedimiento de ajuste

1. Introduzca la señal de 1 kHz y los datos digitales de 0 dB en el terminal de entrada digital (por ejemplo, un reproductor de discos compactos con terminal de salida digital o el disco de prueba YEDS-7).
2. Ajuste VR303 y VR304 de modo que las señales de salida de los terminales (5) y (6) de CN557 sean de $2V \pm 0,1V$.
3. Del mismo modo, ajuste VR301 y VR302 de modo que la distorsión de las señales de salida de los terminales (5) y (6) de CN557 sea de 0,005% o menos (consulte la foto 12-3).



Foto 12-3



Foto 12-4

2V/div
0.2µm sec/div

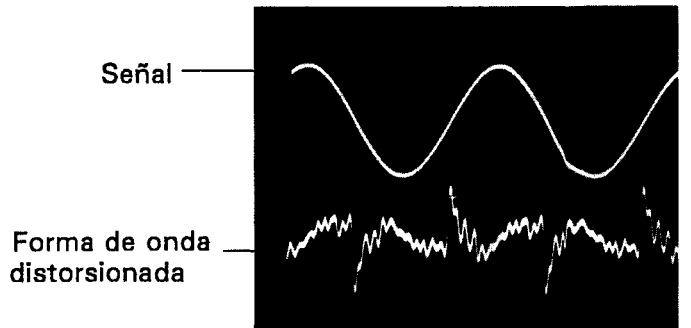
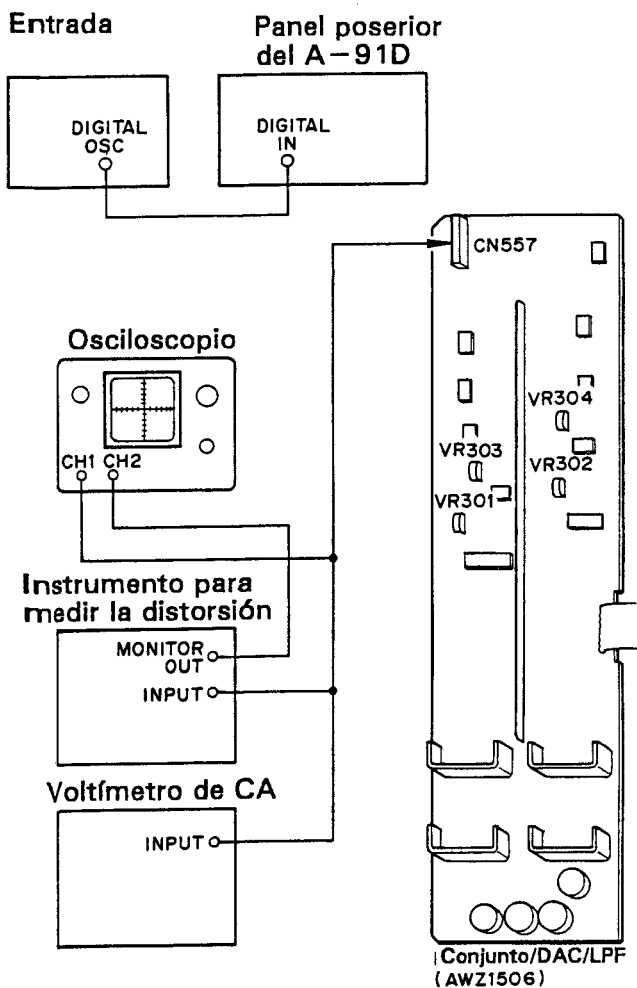
* Se usa el Shiba-Soku 725 para medir la distorsión (margen de 0,01%) y se activa LPF de 30 kHz

13. FOR HB, HEZ AND SD/G TYPES

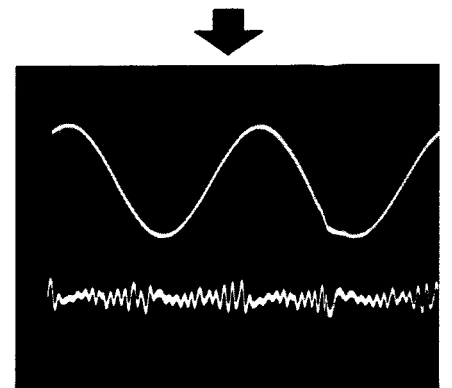
CONTRAST OF MISCELLANEOUS PARTS

The A-91D/HB, HEZ and SD/G types are the same as the A-91D/KU/CA type with the exception of the following sections.

Mark	Symbol & Description	Part No.				Remarks
		A-91D/ KU/CA type	A-91D/ HEZ type	A-91D/ HB type	A-91D/ SD/G type	
△★	T1 Power transformer (120V)	ATS1097	
△★	T1 Power transformer (220V/240V)	ATS1099	ATS1099	
△★	T1 Power transformer (110V/120-127V/220V/240V)	ATS1101	
△★	T2 Power transformer (120V)	ATS1098	
△★	T2 Power transformer (220V/240V)	ATS1100	ATS1100	
△★	T2 Power transformer (110V/120-127V/220V/240V)	ATS1102	
△★	T3 Power transformer	ATT1047	ATT1048	ATT1048	ATT1047	
△	AC socket (OUTLET 3P)	AKP-515	AKP-515	
△★★	S3 Line voltage selector	AKX1022	AKX1022	AKX1022	
△★★	S4 Line voltage selector (110V/120-127V/220V/240V)	AKX-507	
△★★	FU3, FU4, FU5, FU6 Fuse (T1A/125V)	AEK-119	AEK-119	
△★★	FU3, FU4, FU5, FU6 Fuse (T800mA/250V)	AEK-031	
△★★	FU3, FU4, FU5, FU6 Fuse (T800mA/250V)	AEK-507	
△★★	FU1, FU2 Fuse (T6.3A/125V)	AEK-309	
△★★	FU1, FU2 (T2A/250V)	AEK-511	
△★★	FU7, FU8 Fuse (T2A/250V)	AEK-017	
△★★	FU1, FU2, FU7, FU8 Fuse (T3.15A/125V)	AEK-124	
△	AC Power cord	ADG-089	ADG1021	ADG-063	ADG-087	
△	C4 Ceramic capacitor	ACG1003	
	Operating Instructions (English)	ARB1076	ARB1076	ARB1076	
	Operating instructions (English/German/French/Italian)	ARE1068	
	Operating instructions (Spanish)	ARC1069	
	Packing case	AHD1261	AHD1261	AHD1261	AHD1264	
	Spacer	AHB-098	

A-91D / HB, HEZ, SD / G

For HB and HEZ types

*Note:
For voltage change see the following table.

Line Voltage	FU1, FU2	FU7, FU8	Wiring connection
220V (HEZ)	Not used	used	⑤② - ⑤③
240V (HB)	used	Not used	⑤③ - ⑤④

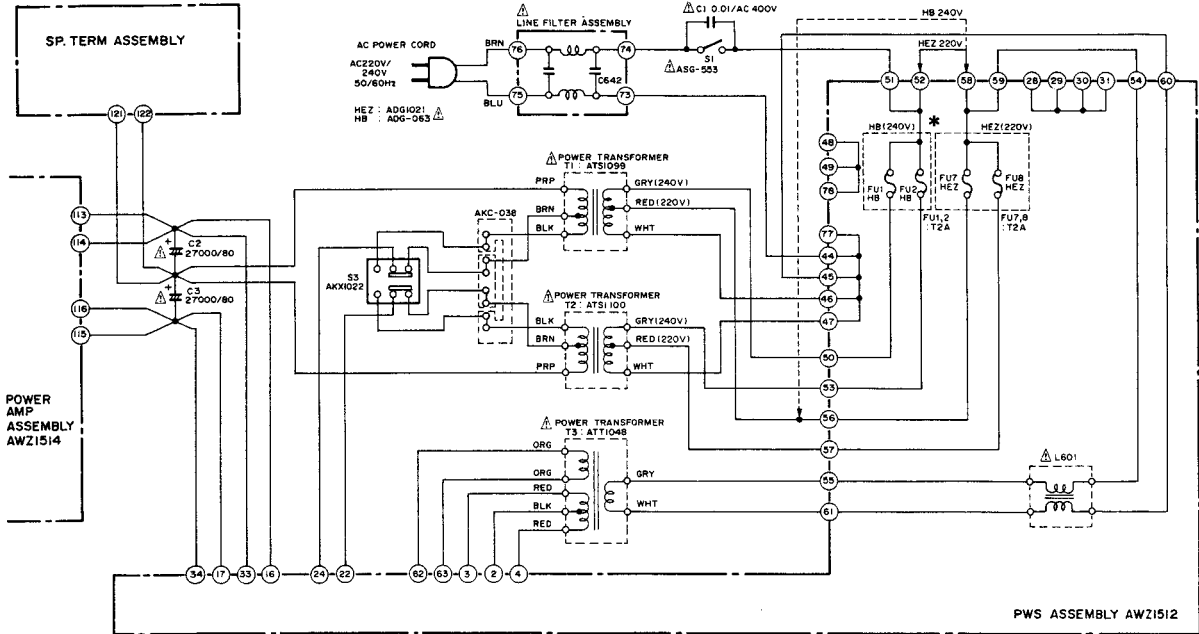

For SD/G type

