

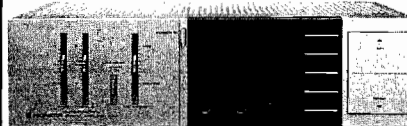

PIONEER®

Service Manual

**CIRCUIT DESCRIPTIONS
REPAIR & ADJUSTMENTS**

**ORDER NO.
ARP-224-0**
STEREO AMPLIFIER

A-X7

MODEL A-X7 COMES IN SIX VERSIONS DISTINGUISHED AS FOLLOWS:

Type	Voltage	Remarks
KU	AC120V only	U.S.A. model
NE	AC220V only	Europe model
YB	AC240V only	United Kingdom model
S	AC110V, 120V, 220V and 240V (Switchable)	General export model
S/G	AC110V, 120V, 220V and 240V (Switchable)	U.S. Military model
NEZ	AC220V only	West Germany model

- This service manual is applicable to the KU type. When repairing the NE, YB, S/G and S types, please see page 30~37.
- The A-X7 includes no adjustment positions.

CONTENTS

1. FRONT PANEL FACILITIES	2	6. SCHEMATIC DIAGRAM	13
2. SPECIFICATIONS	4	7. BLOCK DIAGRAM	17
3. PARTS LOCATIONS	4	8. CIRCUIT DESCRIPTIONS	19
4. EXPLODED VIEW	6	9. ELECTRICAL PARTS LIST	26
5. P.C. BOARDS CONNECTION DIAGRAM	9	10. PACKING	29
		11. FOR NE, YB, S AND S/G TYPES	30

PIONEER ELECTRONIC CORPORATION 4-1, Meguro 1-Chome, Meguro-ku, Tokyo 153, Japan
PIONEER ELECTRONICS [USA] INC. 1925 E. Dominguez St., Long Beach, California 90810 U.S.A.
PIONEER ELECTRONIC [EUROPE] N.V. Keetberglaan 1, 2740 Beveren, Belgium
PIONEER ELECTRONICS AUSTRALIA PTY. LTD. 178-184 Boundary Road, Braeside, Victoria 3195, Australia

1. FRONT PANEL FACILITIES

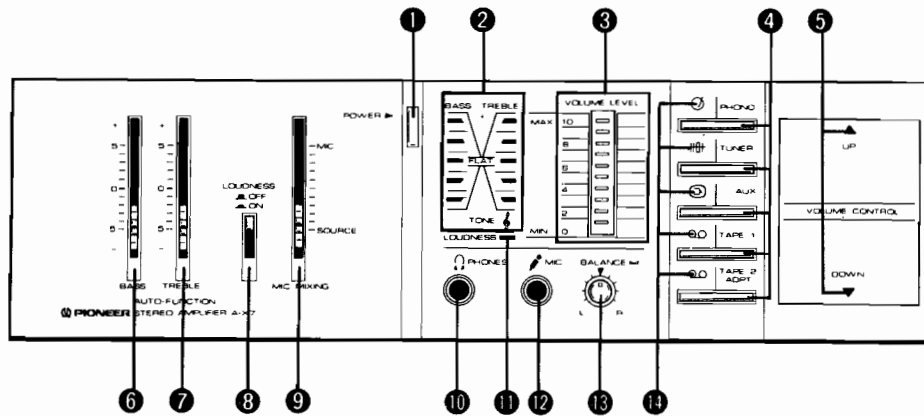

1 POWER SWITCH

Push this switch to turn on the power. Release it to turn off the power.

NOTE:

When combining this unit with the F-X7 synthesizer tuner by PIONEER, plug the unit's power cord into the power outlet provided on the F-X7. Keep the amplifier's power switch at ON all the time and switch the A-X7's power ON and OFF using the power switch on the F-X7.

When the power switch is at ON, the TUNER function is automatically selected.

2 TONE INDICATORS

These light in accordance with the settings of the tone controls 6 and 7.

3 VOLUME LEVEL INDICATOR

This indicator shows the volume of the sound produced when the VOLUME CONTROL switches are operated.

4 MANUAL FUNCTION SWITCHES

These switches are used when the unit is used in combination with components which are not provided with a one-touch auto play function (components except for PIONEER's F-X7, CT-X6 and PL-X9).

PHONO: For playing records on the turntable connected to the rear panel PHONO terminals.

TUNER: For listening to broadcasts on a tuner connected to the rear panel TUNER terminals.

AUX: For playing a stereo component connected to the rear panel AUX terminals.

TAPE 1: For playing back a tape on the tape deck connected to the rear panel TAPE 1 terminals.

TAPE 2/ADPT: For playing back a tape on a second tape deck or playing an adaptor component (such as a sound processor) connected to the rear panel TAPE 2/ADAPTOR terminals.

NOTE:

- When a function switch is set while a tape is being played back in a cassette deck, the tape stops automatically.
- When a function switch is set while a record is being played, the turntable's tonearm automatically returns and the platter stops rotating.

5 VOLUME CONTROL SWITCHES

These are used to adjust the volume.

VOLUME UP ▲ : Press to increase the volume.

VOLUME DOWN ▼ : Press to reduce the volume.

6 BASS CONTROL

This is used to adjust the bass (low-frequency) sound.

The bass is boosted when the control is slid upward from the center "0" position and attenuated when slid downward.

7 TREBLE CONTROL

This is used to adjust the treble (high-frequency) sound.

The treble is boosted when the control is slid upward from the center "0" position and attenuated when slid downward.

8 LOUDNESS SWITCH

Push this switch to the ON position to listen to a program at a low level of sound. The bass and treble are boosted and you can enjoy a dynamic sound even at a low level.

9 MIC MIXING CONTROL

This is used for mixing sound with that of a microphone.

When the control is slid upward, the microphone volume is increased; when slid downward, the sound of the program source (record or FM broadcast, etc.) only is heard.

NOTE:

Keep this control at the bottom (SOURCE) position when you are not performing a mic mixing operation. If this control is at a higher position, no sound will be heard even if the VOLUME CONTROL switches are operated to increase the volume.

**10 HEADPHONES JACK
(PHONES)**

Connect the headphones plug properly to this jack.

When the headphones are connected, no sound will be heard through the speakers.

NOTE:

Get into the habit of turning down the volume before plugging in the headphones. Loud sounds can damage your ears.

11 LOUDNESS INDICATOR

This lights when the LOUDNESS switch is set to ON.

12 MICROPHONE JACK (MIC)

Connect the microphone's plug properly to this jack.

NOTE:

If the microphone used comes with a mini plug, use the optional JK-6 plug adaptor.

**13 BALANCE CONTROL
(BALANCE)**

When the control is rotated clockwise, the sound from the right speaker is increased; when rotated counterclockwise, the sound from the left speaker is increased.

NOTE:

When the control is rotated to its rightmost or leftmost position, no sound will be heard from the opposite speaker.

14 FUNCTION INDICATORS

These indicate the position of the function switch. The indication marks are PHONO, TUNER, AUX, TAPE 1 and TAPE 2/ ADAPT, from the top.

NOTE:

The function is selected automatically by operating the components when the unit is used in combination with components, such as the F-X7, CT-X6 and PL-X5 by PIONEER, which are equipped with a one-touch auto play function.

2. SPECIFICATIONS

Amplifier Section

Continuous Average Power Output is 47 watts* per channel, min., at 8 ohms from 20 Hertz to 20,000 Hertz with no more than 0.07% total harmonic distortion.**

Total Harmonic Distortion (20 Hertz to 20,000 Hertz, 8 ohms, from AUX)

continuous rated power output . . . No more than 0.07%
30 watts per channel power output
..... No more than 0.07%

Damping Factor 1,000 Hertz, 8 ohms) 35
Input (Sensitivity/Impedance)

PHONO 2.5 mV/50 kilohms
TUNER, AUX, TAPE PLAY, ADAPTOR IN

..... 150mV/50 kilohms
MIC 1 mV/5 kilohms

Phono Overload Level (T. H. D. 0.1%, 1,000 Hz)
PHONO 60mV

Output (Level/Impedance)
TAPE REC, ADAPTOR OUT 150mV/50 kilohms
Speaker 6 ~ 16Ω

Frequency Response
PHONO (RIAA Equalization)

..... 20 Hz to 20,000 Hz ±0.3dB
TUNER, AUX, TAPE PLAY, ADAPTOR

..... 20 Hz to 50,000 Hz $\pm\frac{1}{-2}$ dB

Tone Control
BASS ±10 dB (100 Hz)
TREBLE ±10 dB (10 kHz)

Loudness Contour (Volume control set at -40 dB position)
..... +8 dB (100 Hz), +4 dB (10 kHz)

Hum and Noise (IHF, short-circuited A network)
PHONO 80 dB
TUNER, AUX, TAPE PLAY, ADAPTOR IN . . 100 dB

Miscellaneous

Power Requirements AC120 V, 60 Hz
Power Consumption 130 Watts (UL)

Dimensions 320 (W) x 98 (H) x 222 (D) mm
12-5/8 (W) x 3-7/8 (H) x 8-3/4 (D) in

Weight (without package) 5.6 kg (12 lb 5 oz)

Furnished Parts

Operating Instructions 1

**Measured pursuant to the Federal Trade Commission's Trade Regulation rule on Power Output Claims for Amplifier.*

***Measured by Audio Spectrum Analyzer.*

NOTE:

Specifications and design subject to possible modification without notice.

3. PARTS LOCATIONS

NOTES:

- Parts without part number cannot be supplied.
- The Δ mark found on some component parts indicates the importance of the safety factor of the part. Therefore, when replacing, be sure to use parts of identical designation.
- For your Parts Stock Control, the fast moving items are indicated with the marks **★★** and **★**.
★★ GENERALLY MOVES FASTER THAN ★.
This classification shall be adjusted by each distributor because it depends on model number, temperature, humidity, etc.

Front Panel

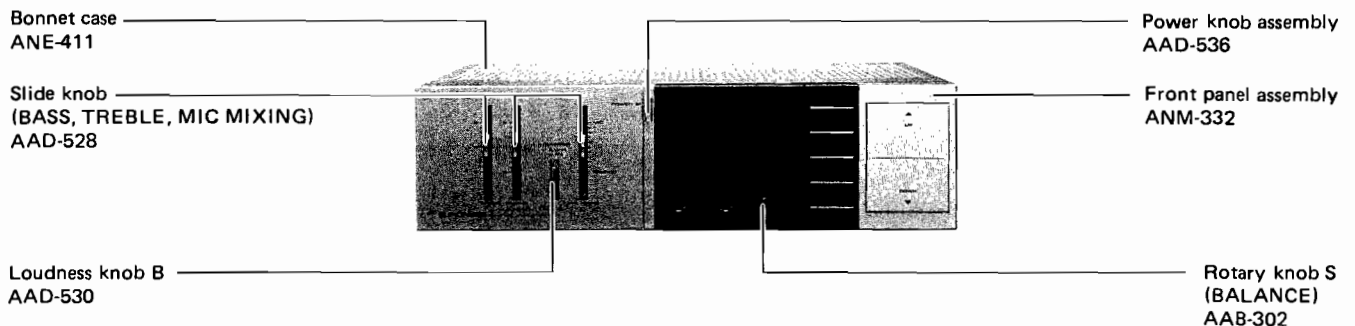

Rear Panel

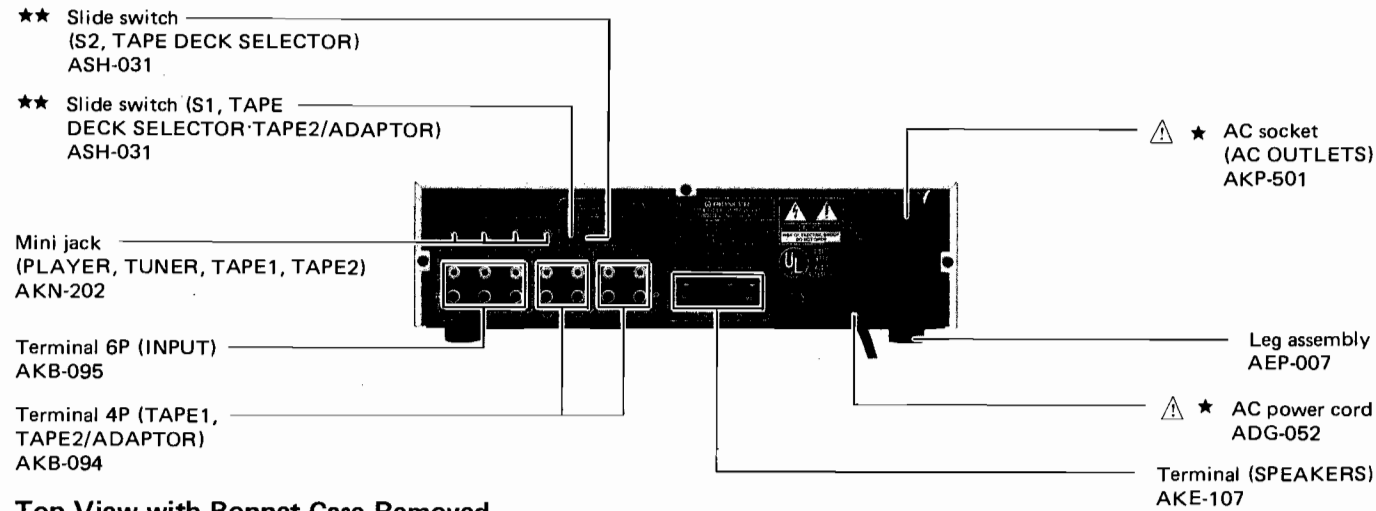

Top View with Bonnet Case Removed

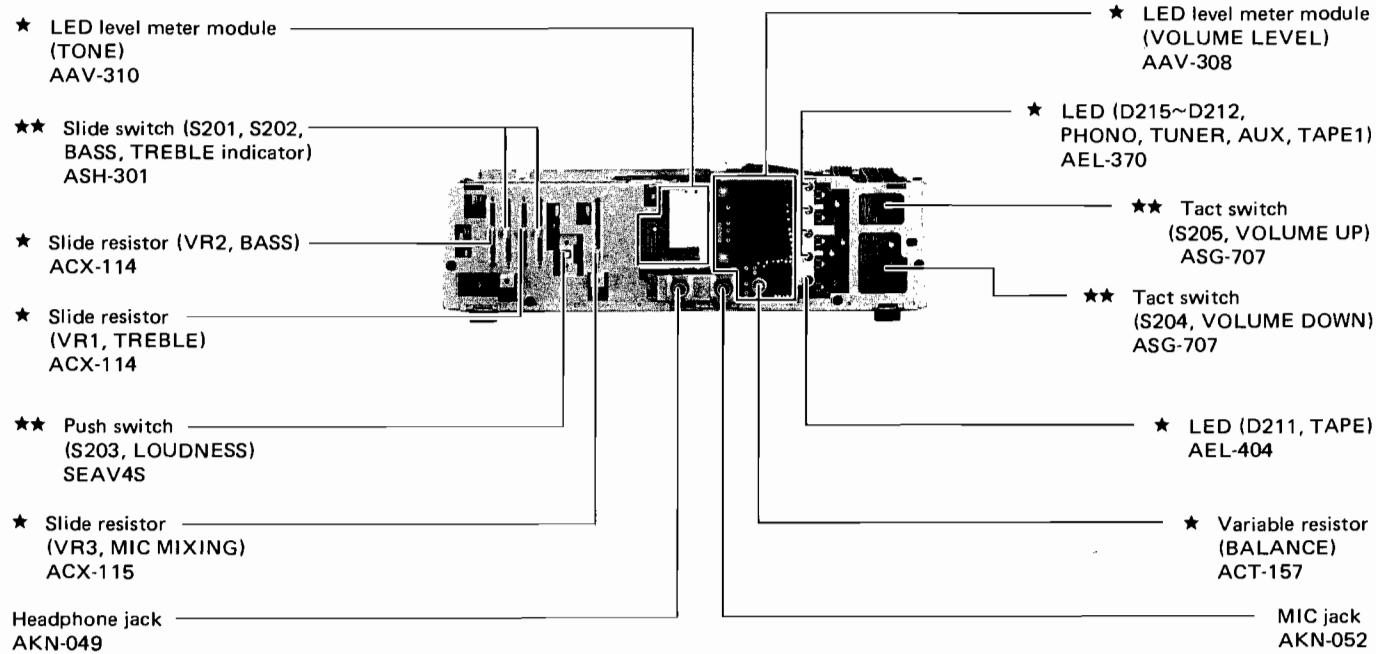

Front View with Front Panel Removed

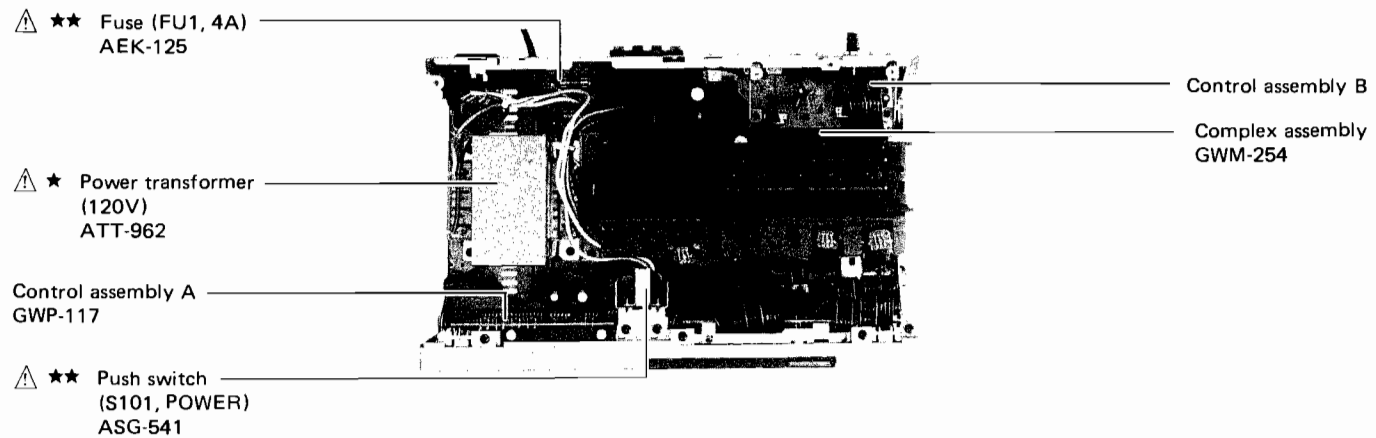

4. EXPLODED VIEW

NOTES:

- Parts without part number cannot be supplied.
- The Δ mark found on some component parts indicates the importance of the safety factor of the part. Therefore, when replacing, be sure to use parts of identical designation.
- For your Parts Stock Control, the fast moving items are indicated with the marks ★★ and ★.
- ★★ **GENERALLY MOVES FASTER THAN ★.**
- This classification shall be adjusted by each distributor because it depends on model number, temperature, humidity, etc.

Parts list

Mark	No.	Part No.	Description	Mark	No.	Part No.	Description
	1.	ANE-411	Bonnet case		32.	AKH-005	Spacer
	2.	BBZ30P080FZK	Screw 3 x 8		33.	ABA-257	Screw ϕ 2.5
	3.	AEC-471	Nylon rivet		34.	AEC-942	Sheet
	4.	AEC-510	Nylon rivet	★★	35.	2SA1216/A/-Y*	Transistor (Q3, Q4)
	5.	AAD-528	Slide knob (BASS, TREBLE, MIC MIXING)			(2SA1216/A/-P)*	
						(2SA1216/A/-G)*	
	6.	AEC-800	Flexible joint	★★	36.	2SC2922/A/-Y*	Transistor (Q1, Q2)
	7.	AAD-530	Loudness knob B (LOUDNESS)			(2SC2922/A/-P)*	
	8.	AAD-536	Power knob assembly			(2SC2922/A/-G)*	
	9.	PMZ20P030FZK	Screw 2 x 3				* hfe of Q1-Q4 should have the same value.
	10.	BMZ30P060FMC	Screw 3 x 6		37.	ABA-258	Screw ϕ 3
	11.	ANM-332	Front panel assembly	Δ	38.	AKP-501	AC socket
	12.	AAD-533	Control knob assembly (VOLUME UP/DOWN)	Δ	39.	ADG-052	AC power cord
	13.	BBZ23P060FZK	Screw 2.3 x 6	Δ	40.	ABN-048	Nut
	14.	ABH-101	Coil spring		41.	ACG-017	Ceramic capacitor (C101, C102 0.01/AC125V)
	15.			42.	AEC-327	Strain relief Capacitor (C102)
						CKDYF 473Z50	
	16.	AAD-529	Function knob B		101.		Plate
	17.	NB70FZB	Nut		102.		Front panel
	18.	AAB-302	Rotary knob S (BALANCE)		103.		Mounting plate
	19.	BBZ30P080FZK	Screw 3 x 8		104.		Panel stay
Δ	★	ATT-962	Power transformer (120V)		105.		Heat sink holder
Δ	★★	ASG-541	Push switch (S101, POWER)		106.		Jack assembly
	★	AAV-310	LED level meter module (TONE)		107.		Spacer
	★	AAV-308	LED level meter module (VOLUME)		108.		Bottom plate
	24.	GWP-117	Control assembly A		109.		Driver assembly
	25.	BBZ30P060FMC	Screw 3 x 6		110.		Chassis
Δ	★★	GWM-254	Complex assembly		111.		P.C.B. spacer
	★	AEK-125	Fuse (FU1, 4A)		112.		Holder
	28.	AEP-007	Leg assembly		113.		Heat sink A
	29.	AEC-841	Mica wafer		114.		Heat sink B
★★	30.	2SD836A	Transistor (Q5, Q6)		115.		Heat sink
★★	31.	2SB750A	Transistor (Q7)		116.		Switch stopper
					117.		Terminal (GND)
					118.		P.C.B. Holder A
					119.		Control assembly B
					120.		Volume assembly
					121.		Volume holder
					122.		Switch holder
					123.		Rear panel
					124.		Panel escutcheon
					125.		Sheet

6. SCHEMATIC DIAGRAM

A

B

C

D

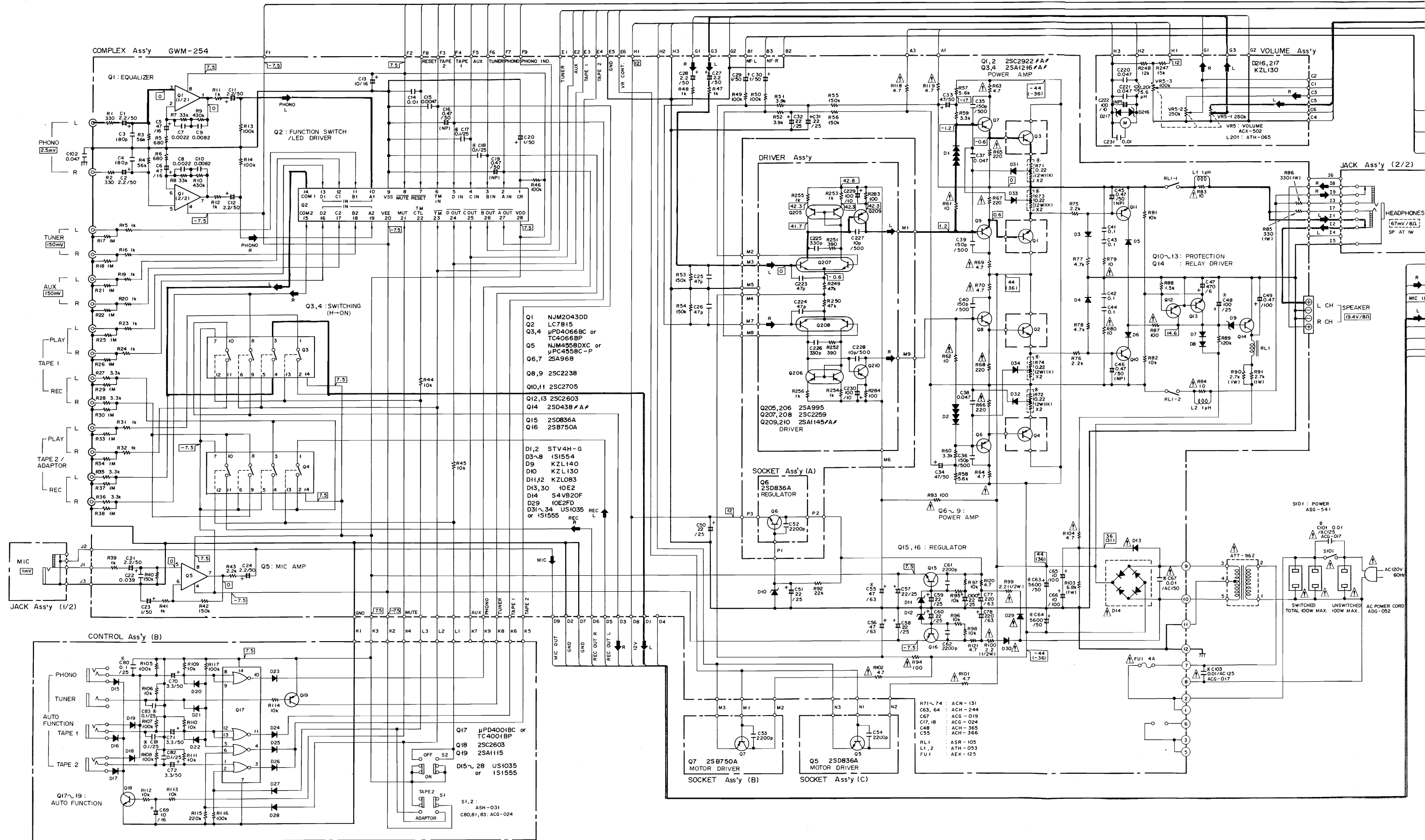

1

2

3

4

5

6

NOTE: The indicated semiconductors are representative ones only. Other alternative semiconductors may be used and are listed in the parts list.

External Appearance of Transistors and ICs

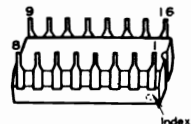
M54562P  Lot No, Index

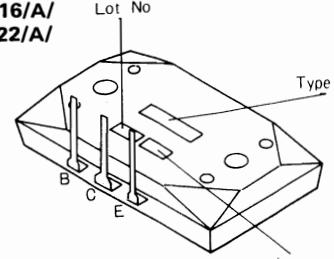
2SA1216/A/ 2SC2922/A  Lot No, Type No, hFE

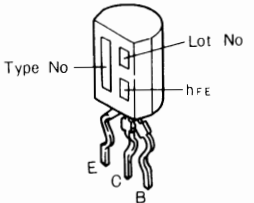
2SD438/A  Lot No, Type No, hFE

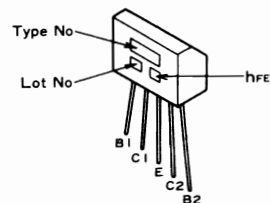
2SC2259  Lot No, Type No, hFE, B1, C1, E, C2, B2

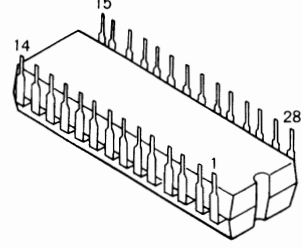
LC7815  15, 14, 28

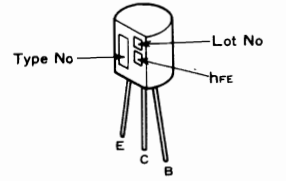
2SC2705  Lot No, Type No, hFE, E, C, B

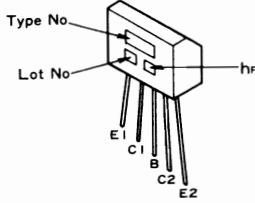
2SA995  Lot No, Type No, hFE, E1, C1, B, C2, E2

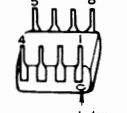
NJM2043DD NJM4558DXC μPC4558C  Lot No, Index

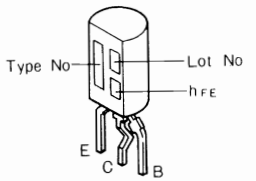
2SA1145/A/ 2SC2603  Lot No, Type No, hFE, E, C, B

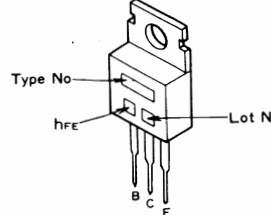
2SA968 2SB750A 2SD836A 2SC2238  Lot No, Type No, hFE, B, C, E

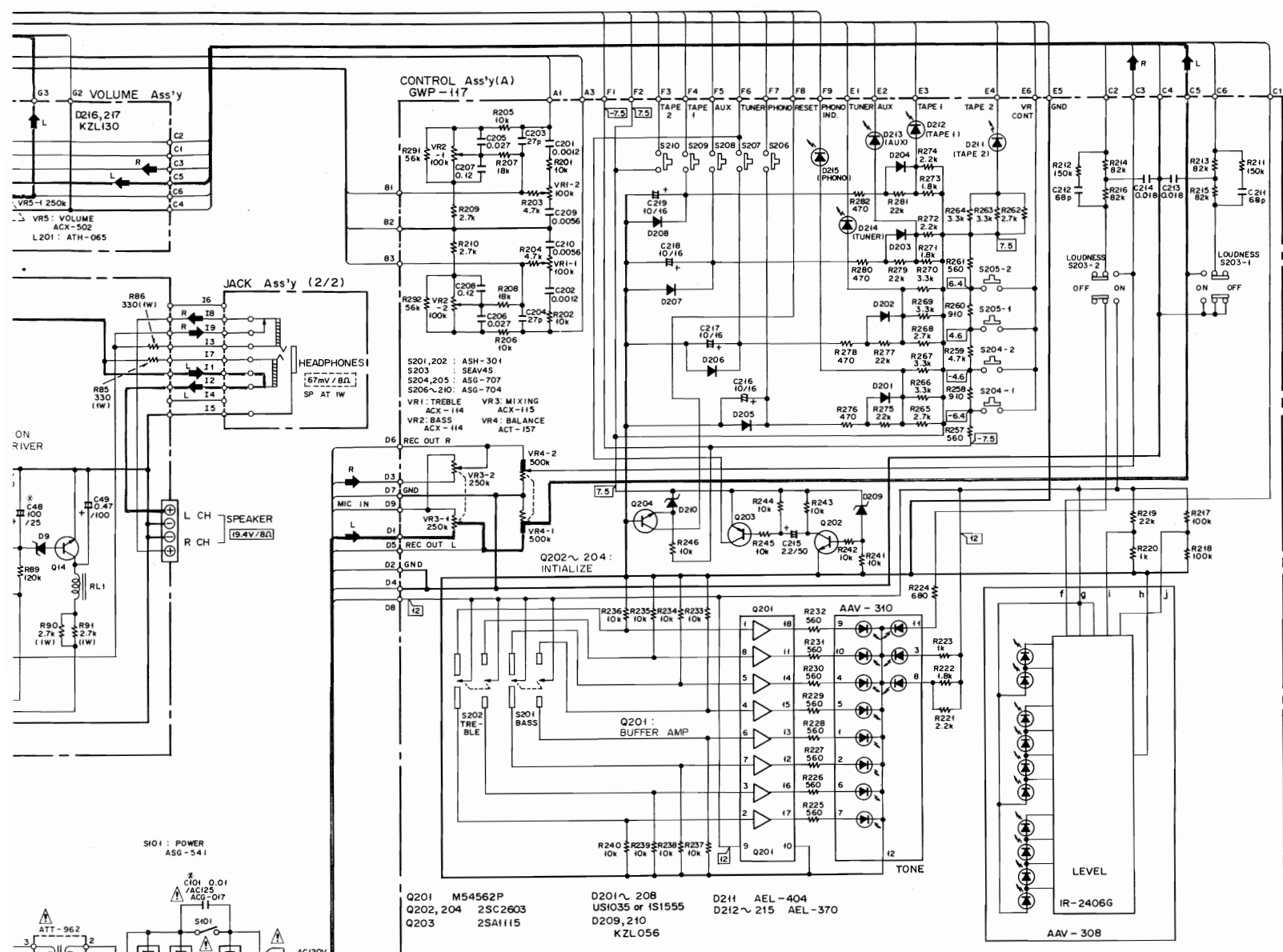

- RESISTORS:** Indicated in Ω, ¼W, ½W, ±5% tolerance unless otherwise noted k; kΩ, M; MΩ, (F); ±1%, (G); ±2%, (K); ±10%, (M); ±20% tolerance
 - CAPACITORS:** Indicated in capacity (μF)/voltage (V) unless otherwise noted p; pF. Indication without voltage is 50V except electrolytic capacitor.
 - VOLTAGE CURRENT:** [V]; Signal voltage at (47 W+ 47 W, 8Ω) output (1kHz) [V]; DC voltage (V) at no input signal Value in () is DC voltage at rated power.
 - OTHERS:** → Signal route. ⊕ Adjusting point. The mark found on some component parts indicates the importance of the safety factor of the part. Therefore, when replacing, be sure to use parts of identical designation. * marked capacitors and resistors have parts numbers.
- This is the basic schematic diagram, but the actual circuit may vary due to improvements in design.
- SWITCHES:**
 CONTROL Ass'y (A)
 S1 : TAPE DECK SELECTOR TAPE2—ADAPTOR
 S2 : TAPE DECK SELECTOR ON—OFF
 OUTSIDE OF PC BOARD Ass'y
 S101 : POWER ON—OFF
 CONTROL Ass'y (B)
 S201 : BASS INDICATOR ON—OFF
 S202 : TREBLE INDICATOR ON—OFF
 S203 : LOUDNESS ON—OFF
 S204 : VOLUME DOWN ON—OFF
 S205 : VOLUME UP ON—OFF
 S206 : PHONO ON—OFF
 S207 : TUNER ON—OFF
 S208 : AUX ON—OFF
 S209 : TAPE 1 ON—OFF
 S210 : TAPE 2 / ADPT ON—OFF
- The underlined indicates the switch position.

Q201	M54562P	D201~208	2SD1035 or IS1555	D211	AEL-404
Q202, 204	2SC2603	D209, 210	KZL056	D212~215	AEL-370
Q203	2SA1115				

7. BLOCK DIAGRAM

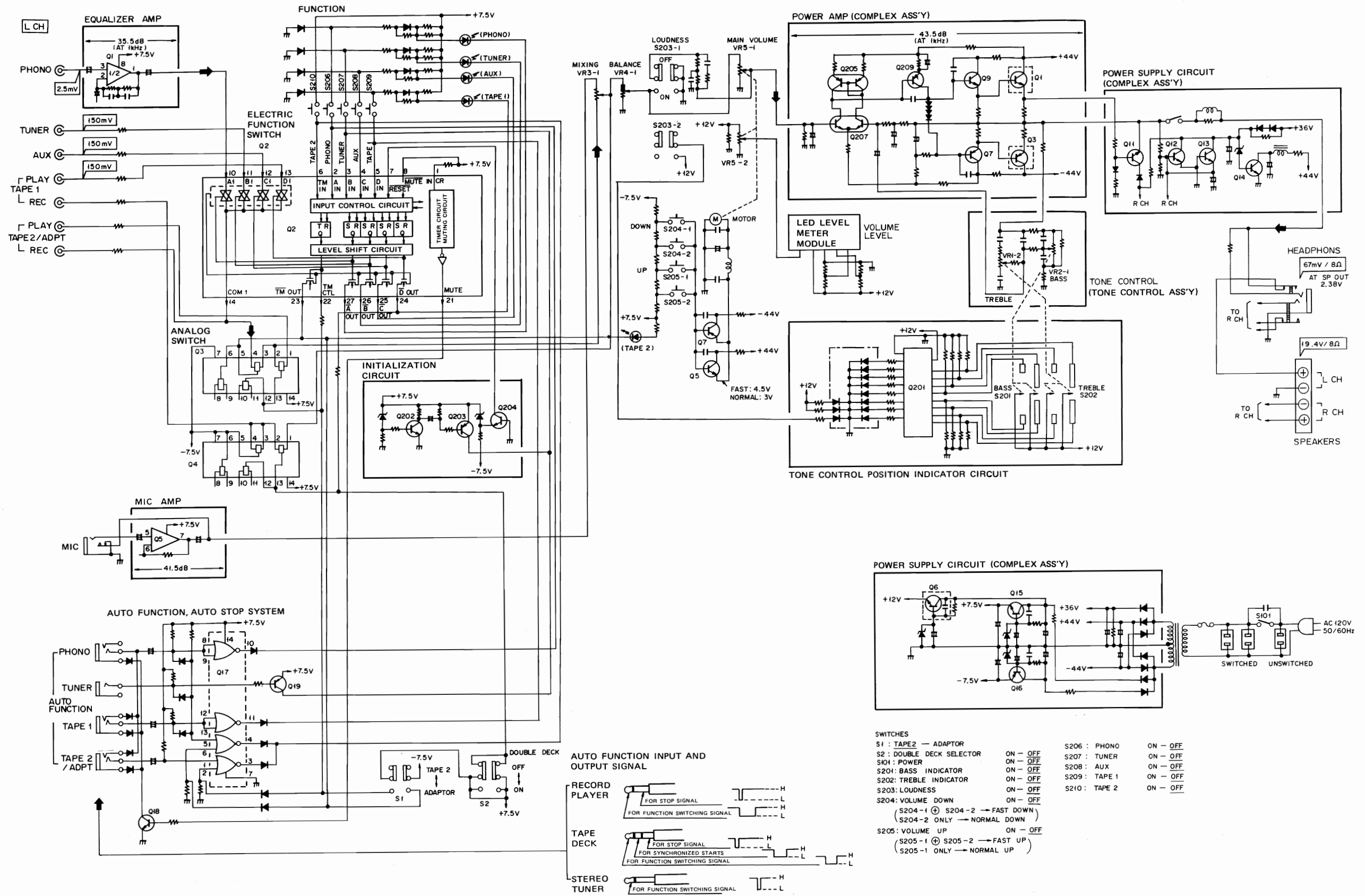

5. P.C.BOARDS CONNECTION DIAGRAM

1 | 2 | 3 | 4 | 5 | 6 | 7

A

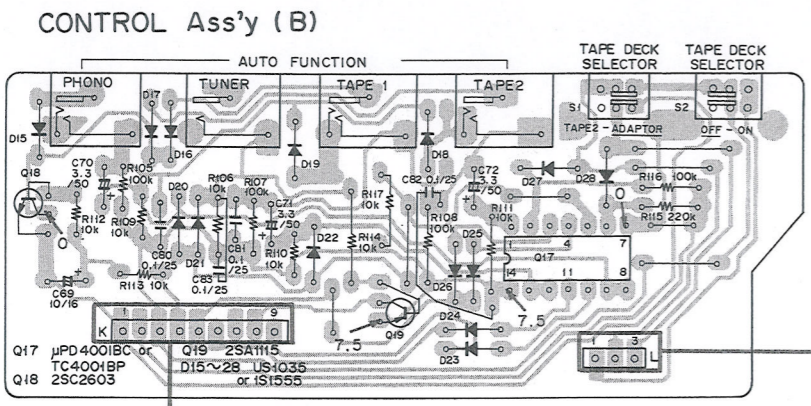

B

SOCKET Ass'y (B)

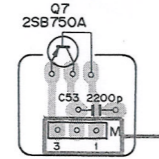

C

SOCKET Ass'y (C)

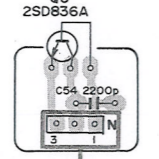

D

JACK Ass'y

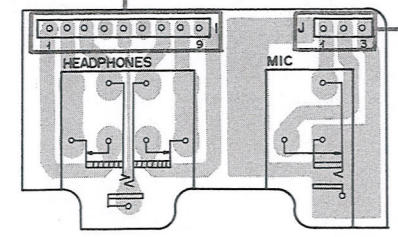

COMPLEX Ass'y GWM-254

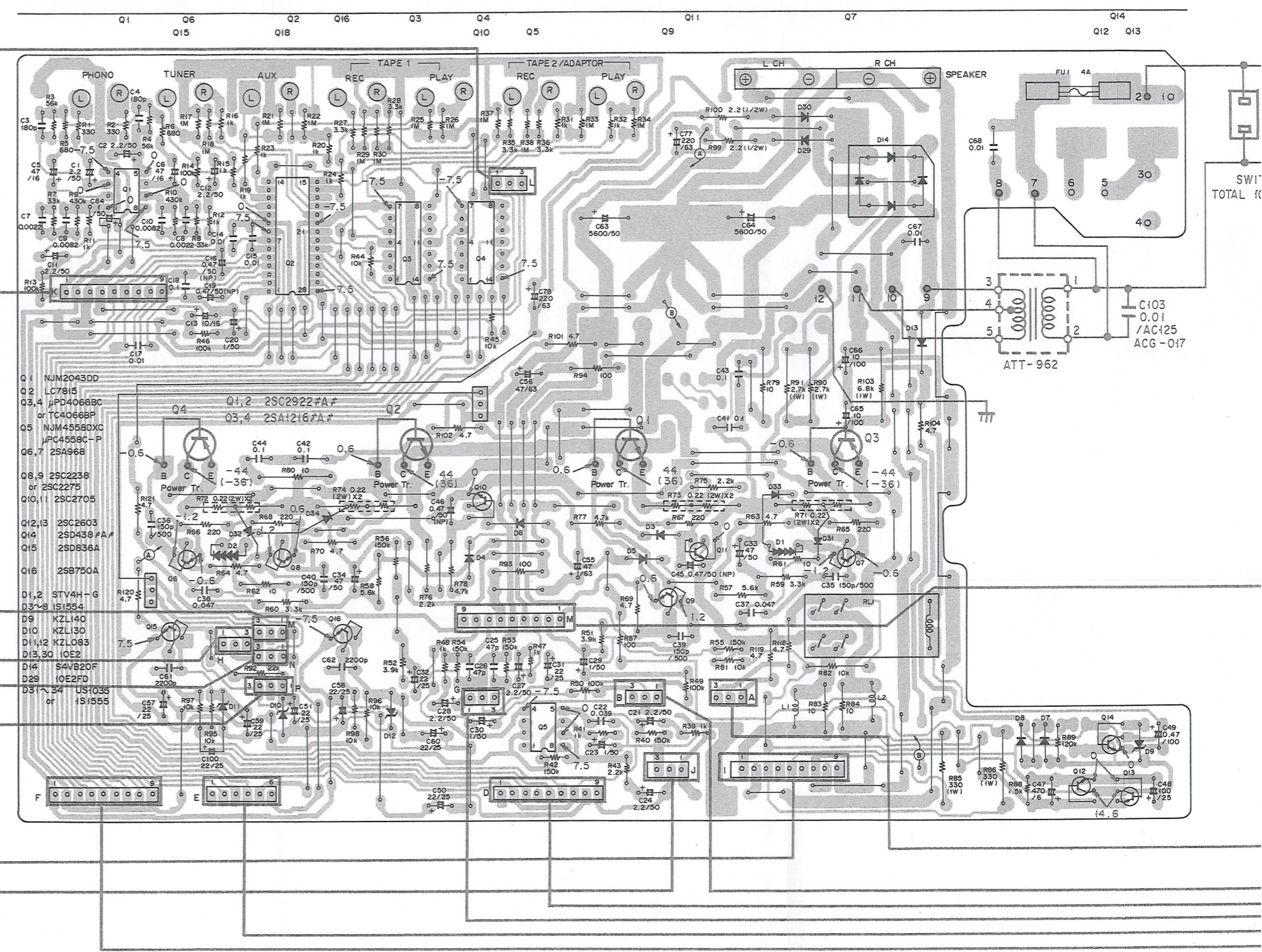

1 | 2 | 3 | 4 | 5 | 6 | 7

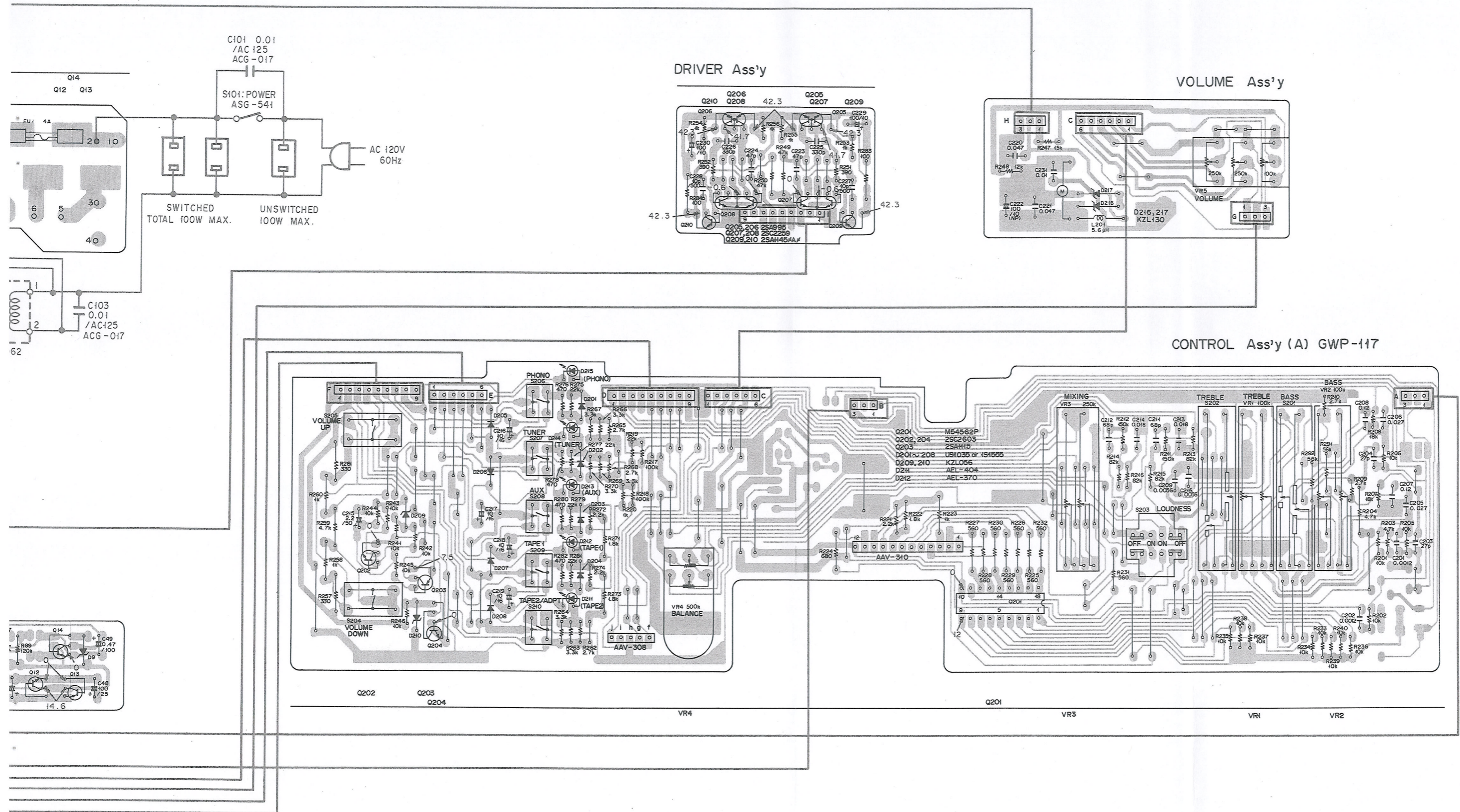

8. CIRCUIT DESCRIPTIONS

Equalizer Amplifier

The equalizer amplifier is a low-noise dual operational amplifier NJM2043DD which includes both left and right channels. In addition to improved input and output stages, the NJM2043DD also has better output characteristics and frequency response than the NJM4558.

Power Amplifier

A current mirror load differential amplifier in the first stage and a bootstrap circuit in the pre-drive stage load achieves a high gain under stable operating conditions. And with a 2-stage Darlington complementary connection in the power amplifier stage, the effective output power of the A-X7 is $47W + 47W$ (8Ω , $20Hz \sim 20kHz$) and the harmonic distortion 0.07% (at the rated output power level, $20Hz \sim 20kHz$).

Tone Control

The tone control circuit consists of C, R, and variable resistor elements in the negative feedback loop of the power amplifier. Tone is thereby controlled by changing the feedback level.

Mic Amplifier

The low-noise operation amplifier NJM4558-DXC serves as the mic amplifier.

Protection Circuit

The protection circuit includes muting when the power switch is switched on and off, speaker protection if a DC voltage is generated at the power amplifier output, and power amplifier protection if an overload is applied to the output stage of the circuit.

Indicators

Tone control position indication involves interlocking switches with the tone controls. When the contact of the switch in the same position as the selected tone control position is closed (ON), a signal is passed via a buffer amplifier to a 5-step tone indicator circuit. Volume level is indicated by applying a positive voltage to an interlocked variable resistor, resulting in an increased or decreased voltage being applied to an LED display.

Output level is indicated in a 10-point LED indicator.

DESCRIPTION OF INDIVIDUAL CIRCUITS

When Power is Switched On (Initialization Circuit Operation see Fig. 8-1)

1. When the power switch is switched on, a voltage of $-7.5V$ is applied to the emitter of

Q204 via R246. When Q204 is thus turned on, pin 7 (RESET) of Q2 is switched to L level, thereby activating the Q2 reset circuit and resetting the function selector position.

2. As the positive voltage applied to the zener diode D210 gradually increases, Q204 is turned off.

3. A voltage of $+7.5V$ is then applied to zener diode D209, Q202 being turned on when the D209 zener voltage is reached.

And once Q202 has been turned on, Q203 is turned on when C215 is charged up in accordance to the R244/C215 time constant.

4. When Q203 is turned on, H level is applied to pin 3 of Q2, and function selector is set to TUNER. Q203 is turned off again when C215 is fully charged.

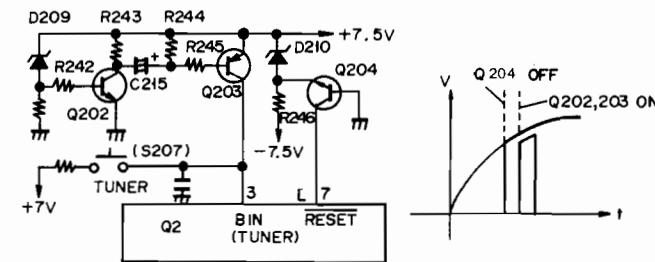

Fig. 8-1 Initialization Circuit

Volume Control Operation (see Fig. 8-2)

The volume control (main volume) of this amplifier is a motorized control. The motor is activated by changes in voltage applied to transistors Q5 (for UP) and Q7 (for DOWN), or by change in the direction of current. The switches for controlling volume adjustment speed are 2-position switches, the first position for NORMAL speed, and the second for FAST speed.

UP (NORMAL)

1. S205-1 is switched on when the first position of the UP volume switch (S205) is pressed. A voltage divided according to the resistance ratio shown in Fig. 8-3 is applied to the base of Q5 to switch that transistor on.

2. The motor is rotated clockwise at the slower speed, and the volume control linked to the motor is moved in the UP direction. The Q5 emitter voltage at this time is about $3V$.

UP (FAST)

3. If the UP switch is pressed further, S205-2 is also switched on, resulting in a voltage divided according to the resistance ratio shown in Fig. 8-3 being applied to the base of Q5.

4. With Q5 turned on, the motor is rotated clockwise at the faster speed, the volume control linked to the motor being again moved in the UP direction. The Q5 emitter voltage in this case is about $4.5V$.

DOWN (NORMAL)

1. S204-2 is switched on when the DOWN switch (S204) is pressed to the first position. A negative voltage divided according to the resistance ratio shown in Fig. 8-3 is applied to the base of Q7 to switch that transistor on.

2. The motor is rotated counter clockwise at the slower speed, and the volume control linked to the motor is moved in the DOWN direction.

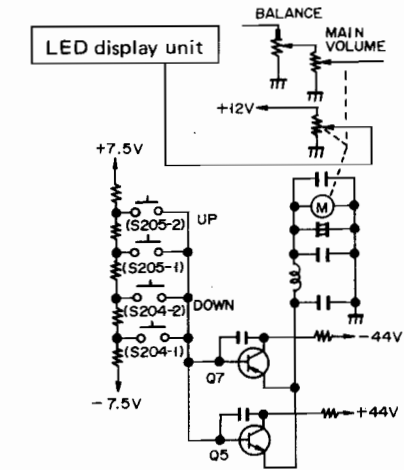

Fig. 8-2 Volume Control Operation

Function Switching Timing Chart

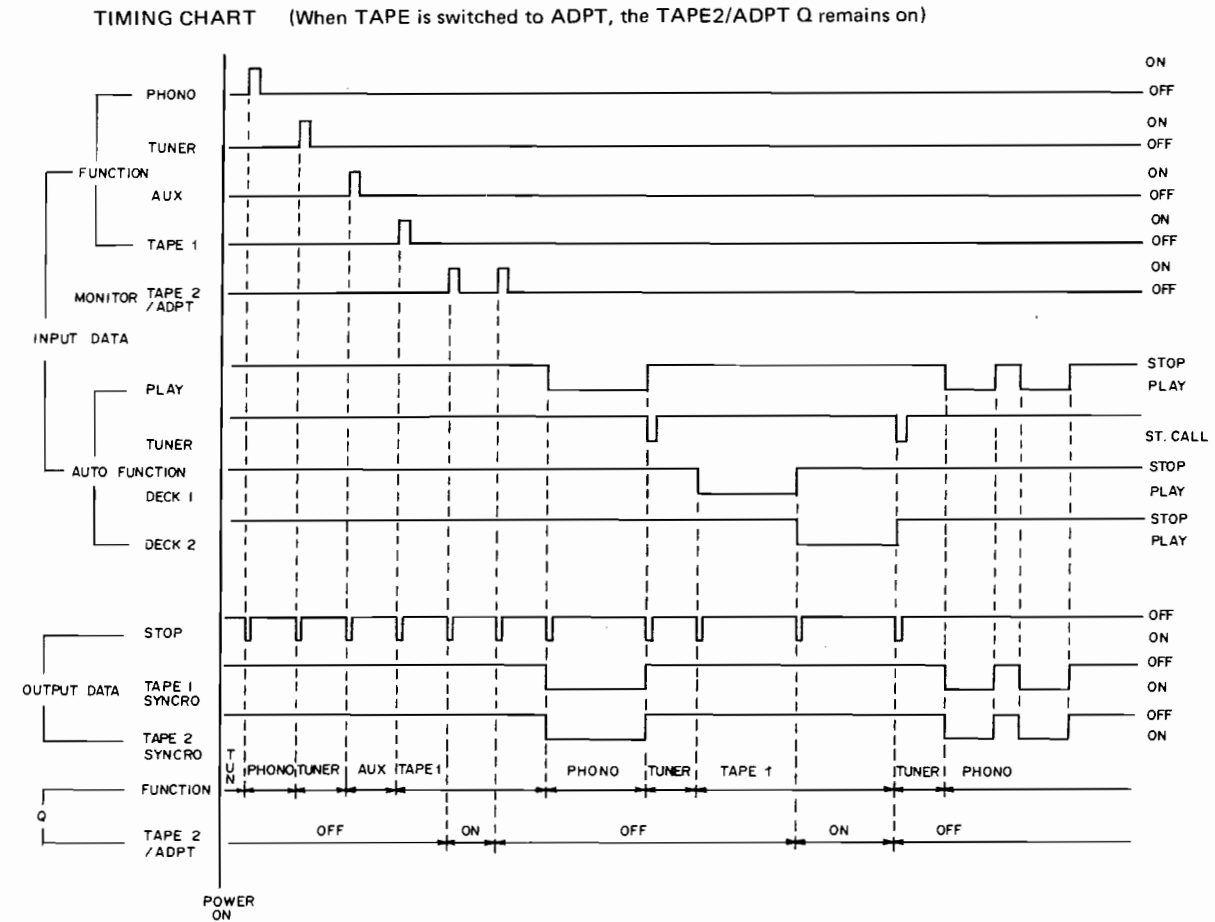

Fig. 8-3 Function switching timing chart

■ DOWN (FAST)

3. If the DOWN switch is pressed further, S204-1 is also switched on, resulting in a voltage divided according to the resistance ratio shown in Fig. 8-3 being applied to the base of Q7.
4. With Q7 turned on, the motor is rotated counter clockwise at the faster speed, the volume control linked to motor being again moved in the DOWN direction.

Function Selection

Function selection in the A-X7 can be performed either manually or automatically. Manual selection involves operation of the relevant front panel controls. Automatic selection is achieved by operation of the relevant component connected to the automatic switching terminals on the rear panel of the amplifier.

The A-X7 amplifier also generates output signals from the PHONO automatic switching terminals to stop the turntable, and output signals from the TAPE1 and TAPE2 terminals to either stop the tape deck, or to cancel pause mode.

The actual function selection is performed by an analog function switch C MOS IC LC7815 in combination with an analog switch C MOS IC μ PD4066BC.

The LC7815 includes the following functions.

- Built-in analog switch corresponding to two circuits and four contacts.
- A control circuit for on/off control of the above analog switch.
- A T flip-flop circuit capable of controlling electronic switching such as tape monitor and muting (and used in A-X7 for TAPE2 switching).
- LED driver circuit for display of function and tape monitor modes.

Function selection is summarized in Fig. 8-4 and Fig. 8-6. PHONO, TUNER, AUX, and TAPE1 are switched by Q2 (LC7815). The Q3 analog switch is equivalent to a tape monitor switch for TAPE2, and is used in control of the tape monitor function. The Q4 analog switch is equivalent to the TAPE1 tape monitor switch, and is activated during recording mode.

Functions of the LC7815 Function Switch

Pin No.	Pin Name	Pin Description
1	CR	• CR time constant terminal for determining the duration of the audio muting control signal.
2 3 4 5	Ain Bin Cin Din	• Input pins for specifying switching of each analog switch. • Order of priority if pressed simultaneously: Ain > Bin > Cin > Din • Prevention of misoperation due to pulse noise (pulse width identified by muting delay time).
6	TM in	• Input pin for specifying tape monitor mode on/off. • Detection of the leading edge of the input signal, and switching monitor mode off if already on, and off if on (inverting action).
7	RESET	• Resetting of all analog switches, and also resetting of the tape monitor flip-flop. (This terminal is "L" level active).
8	MUTEin	• Input pin for external triggering of audio muting control signal (MUTE).
9 20 28	Vss Vee Vdd	Power supply pins.
10 11 12 13	A ₁ B ₁ C ₁ D ₁	• A ₁ to D ₁ and A ₂ to D ₂ are audio signal input pins. • COM1 and COM2 are audio signal output pins.

19	A ₂ B ₂ C ₂ D ₂	<ul style="list-style-type: none"> • Input signals applied to the A₁~D₁ and A₂~D₂ pins are passed according to the Ain~Din designation input signals as shown in the following chart. <table border="1" style="margin-left: 20px;"> <thead> <tr> <th colspan="2">COM output</th> <th>An</th> <th>Bn</th> <th>Cn</th> <th>Dn</th> </tr> </thead> <tbody> <tr> <td rowspan="4">Designation input</td> <td>Ain</td> <td>1</td> <td>0</td> <td>0</td> <td>0</td> </tr> <tr> <td>Bin</td> <td>*</td> <td>1</td> <td>0</td> <td>0</td> </tr> <tr> <td>Cin</td> <td>*</td> <td>*</td> <td>1</td> <td>0</td> </tr> <tr> <td>Din</td> <td>*</td> <td>*</td> <td>*</td> <td>1</td> </tr> </tbody> </table> <p>The * mark denotes "not fixed".</p>	COM output		An	Bn	Cn	Dn	Designation input	Ain	1	0	0	0	Bin	*	1	0	0	Cin	*	*	1	0	Din	*	*	*	1
COM output			An	Bn	Cn	Dn																							
Designation input	Ain		1	0	0	0																							
	Bin		*	1	0	0																							
	Cin	*	*	1	0																								
	Din	*	*	*	1																								
16	D ₂																												
14	COM 1																												
15	COM 2																												
21	MUTE	<ul style="list-style-type: none"> • Audio muting control signal output pin. • Output of signal of pulse width determined by time constant connected to the CR pin when MUTE in input is applied or when function is switched. 																											
22	TMCTL	<ul style="list-style-type: none"> • Output pin for control of external analog switch (TC4066B) for tape monitor. • Complementary buffer output N-channel transistor source is connected to VEE. 																											
23	TM out	<ul style="list-style-type: none"> • In addition to output of signal for control of analog switch (TC4066B) for tape monitor, this pin also supplies the LED driver output to indicate the tape monitor status. • TM out denotes output of the opposite sign to TMCTL. 																											
27 28 29	A out B out C out	<ul style="list-style-type: none"> • LED driver output pins indicating ON status of each corresponding analog switch. 																											
24	D out																												

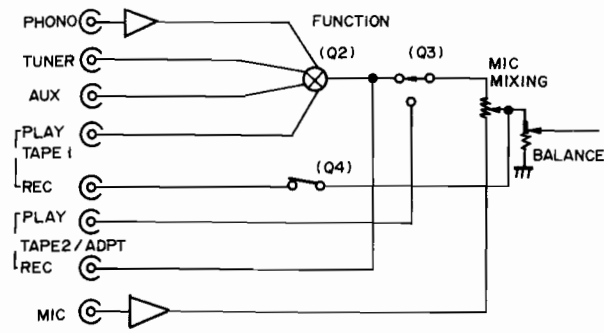

Fig. 8-4 Function Block Diagram

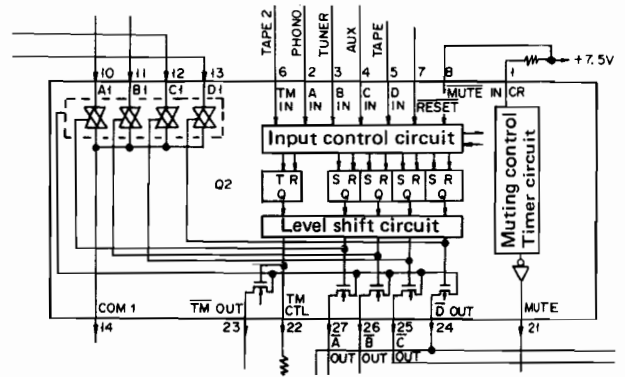
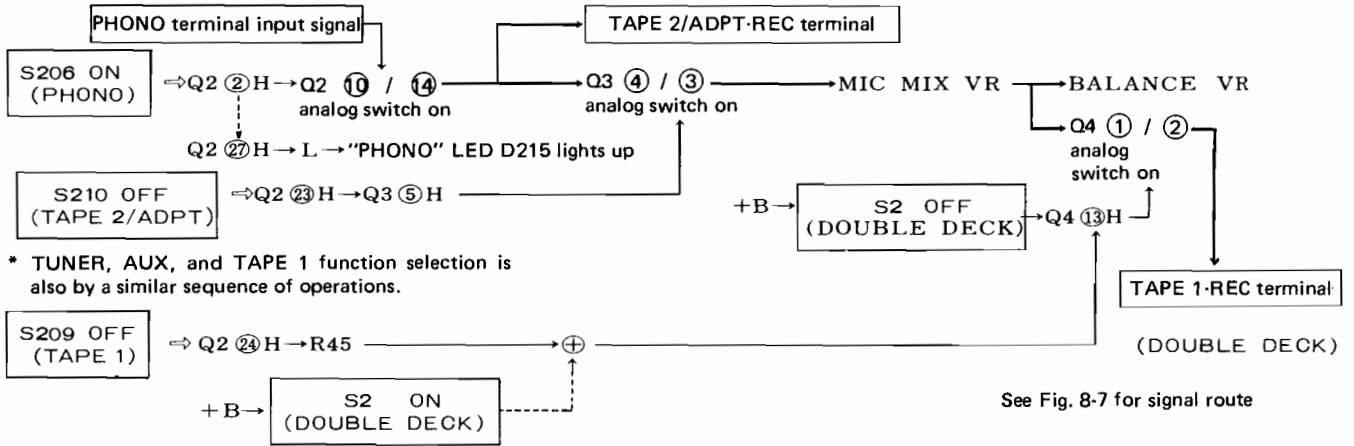

Fig. 8-5 LC7815 Block Diagram

Manual Operation (see Fig. 8-6)

- PHONO switch (S206) on and TAPE 2/ADPT switch (S210) off



- PHONO switch (S206) on and TAPE 2/ADPT switch (S210) on

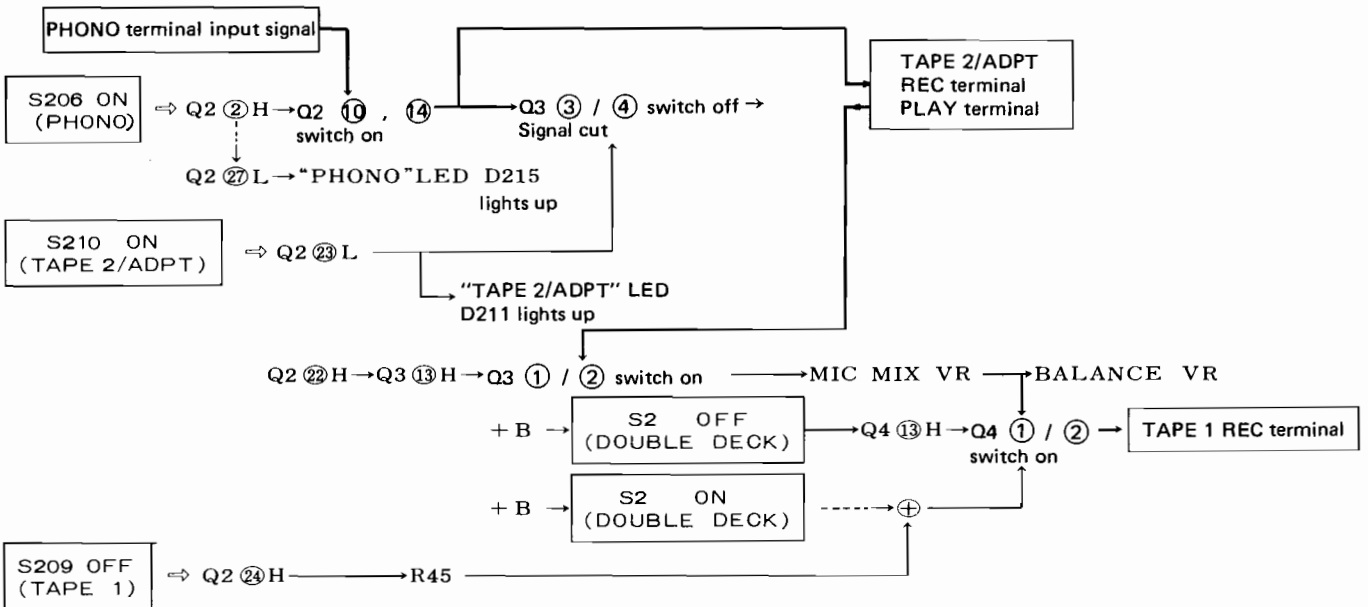

- TAPE 1 switch (S209) on and TAPE 2/ADPT switch (S210) on

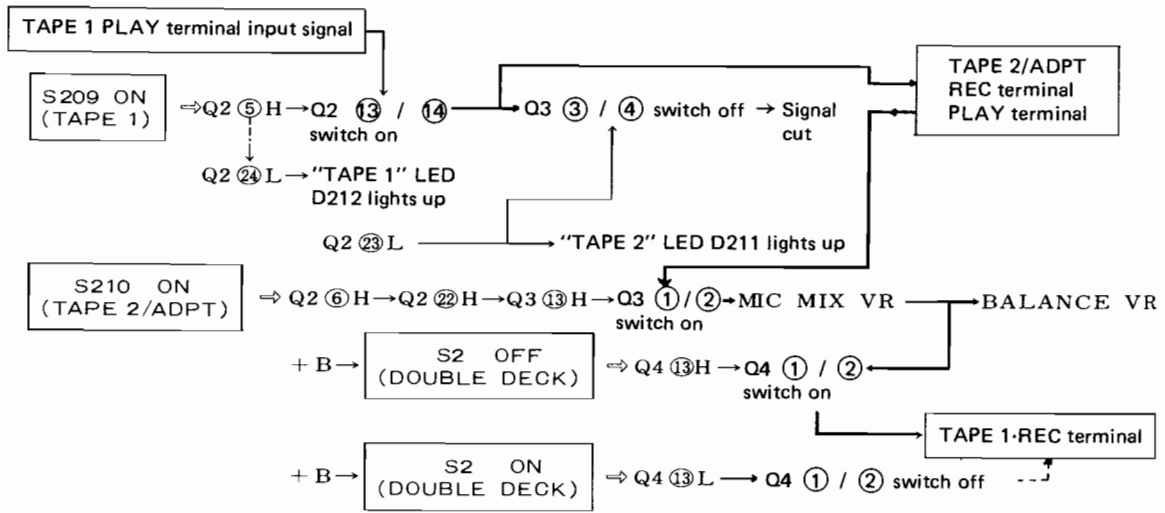

See Fig. 8-9 for signal route.

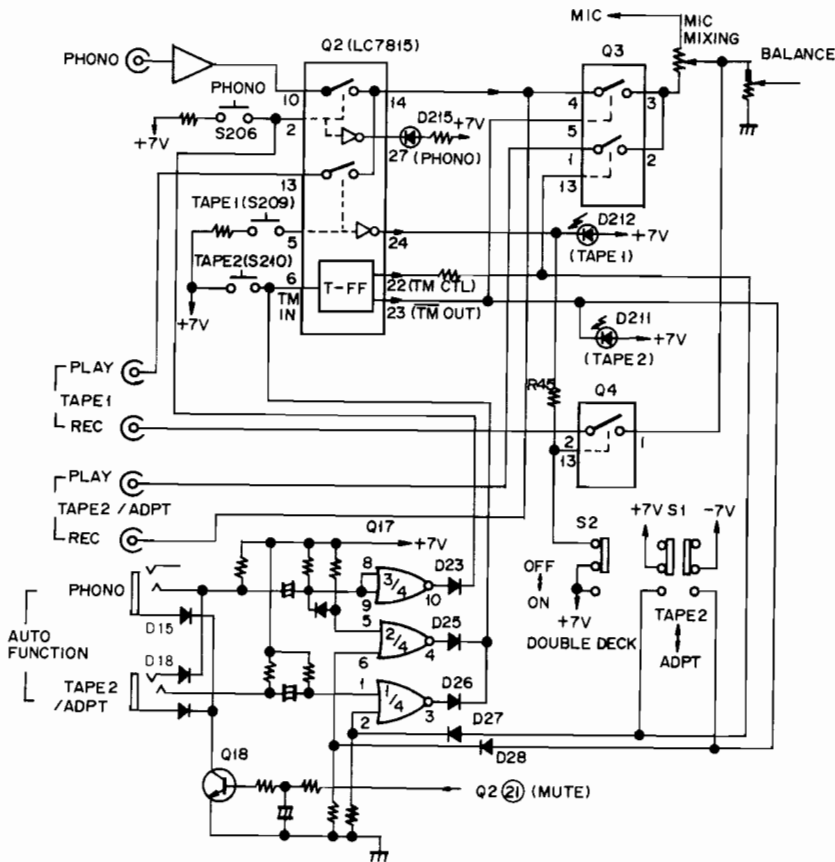

Fig. 8-6 Function Switching

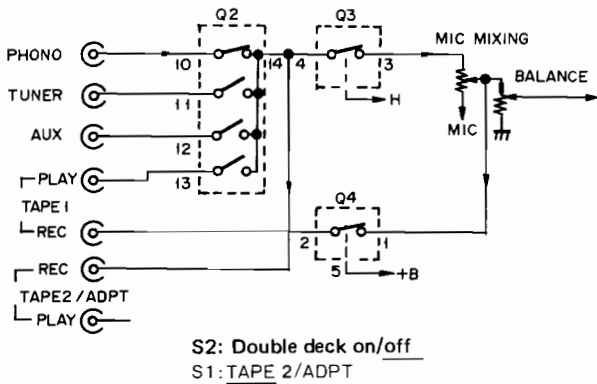

Fig. 8-7 Signal Route when PHONO is Switched On

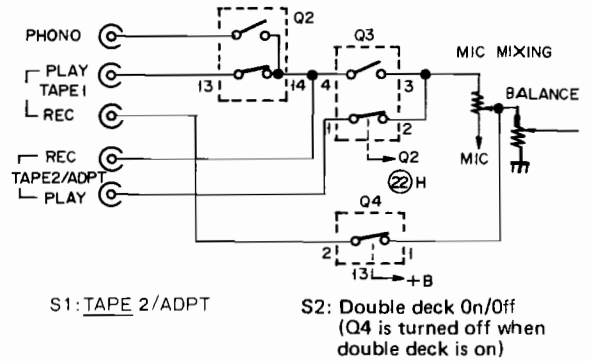

Fig. 8-9 Signal Route when TAPE 1 and TAPE 2/ADPT are Switched On

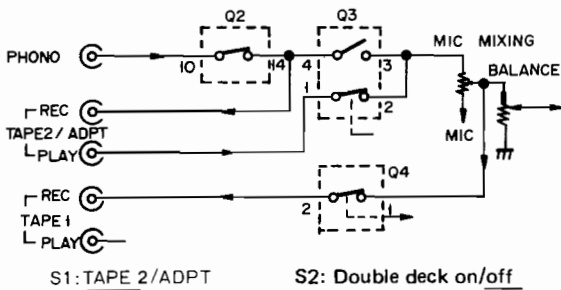

Fig. 8-8 Signal Route when PHONE and TAPE 2/ADPT are Switched On

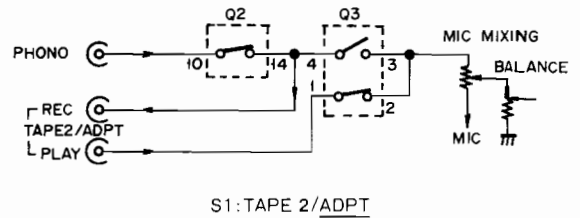

Fig. 8-10 Switching of the TAPE 2/ADPT Switch

■ TAPE 2 switch (S210) operation (see Fig. 8-6)

Pin 6 of the Q2 function switch is the input terminal for specifying tape monitor mode on/off. Upon detection of the leading edge of this input signal, the monitor mode is inverted (that is, switched off if already on, and switched on if off). (The outputs from pins 22 and 23 of Q2 are inverted reciprocally). Hence, TAPE2 tape monitor mode (pins 1 and 3 of Q3) is switched on and off repeatedly each time the TAPE 2 switch (S210) is pressed.

■ TAPE 2/ADPT switch set to "ADPT" position (see Fig. 8-6)

1. If the TAPE2/ADPT switch (S1) is switched to the ADPT position, +B is passed to pin 13 of Q3 via S1. The switch formed by pins 1 and 2 of Q3 is always on.
2. And since -B is applied to pin 5 of Q3 via S1, the switch formed by pins 3 and 4 of Q3 is switched off. Therefore, TAPE 2 mode remains unchanged when the TAPE 2 switch (S210) is switched on and off. The signal route is outlined in Fig. 8-10.

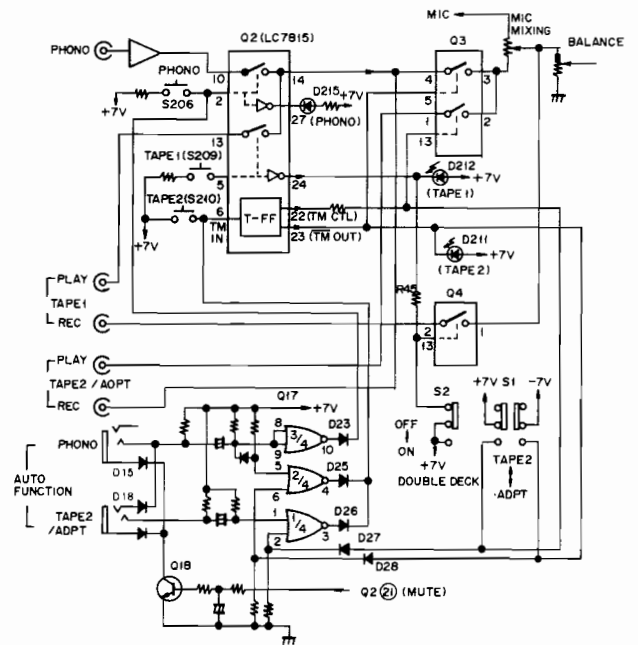

Fig. 8-11 Function Switching

Automatic Switching (see block diagram in Fig. 8-11)

If the signals listed in the block diagram on page 17 are received from the source components connected to the automatic switching terminals on the rear panel of the amplifier, the relevant function is switched in the following way.

■ **PHONO**

Turntable START → “PHONO” terminal \lrcorner signal input → Q17 ⑩ H → D23 → Q2 ② H → Q2 ⑩ / ⑭ switch on → FUNCTION switched on “PHONO” position.

■ **TUNER**

Tuner FUNCTION operation → “TUNER” terminal \lrcorner signal input → Q19 ON → Q2 ③ H → Q2 ⑪ / ⑭ switch on → FUNCTION switched to “TUNER” position.

■ **TAPE 1**

Tape deck 1 operation (recording or playback mode start) → “TAPE 1” terminal \lrcorner signal input → Q17 ⑪ H → D24 → Q2 ⑤ H → Q2 ⑬ / ⑭ switch on → FUNCTION switched to “TAPE 1” position.

■ **TAPE 2 (tape monitor switch)**

Tape deck 2 operation (recording or playback mode start) → “TAPE 2/ADPT” terminal \lrcorner signal input → Q17 ① \lrcorner → \oplus
 If FUNCTION not in “TAPE 2” position → Q2 ⑫ L → Q17 ② L

→ Q17 ③ H → D26 → Q2 ⑥ H → Q2 ⑫ H → Q3 ⑬ H → Q3 ① / ② switch on → TAPE 2 tape monitor switch on.

Note: Automatic switching of TAPE 2 is not possible if the TAPE 2/ADPT switch is in the “ADPT” position.

■ **Input signal for another function apart from TAPE 2 when the TAPE 2 tape monitor circuit (Q3) is operating.**

1. When the TAPE 2 tape monitor circuit (Q3 ① / ② switch on) is operating, the circuit status is as follows.

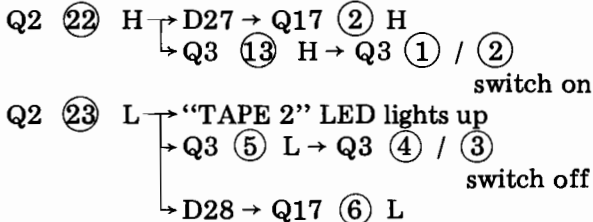

2. If an input signal is then applied from the PHONO, TUNER, AUX, or TAPE 1 auto function switching terminal, the circuit status is changed in the following way.

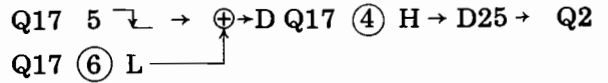

⑥ \lrcorner → Inversion of the Q2 ⑫ and ⑬ outputs

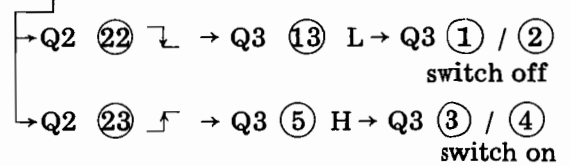

3. That is, the TAPE 2 tape monitor switch (pins 1 and 2 of Q3) is switched off, and FUNCTION is switched to another position (the switch formed by pins 3 and 4 of Q3 is switched on) from the TAPE 2 position.

4. If an L level signal is re-applied to the “TAPE 2/ADPT” terminal while the TAPE monitor switch (pins 1 and 2 of Q3) is on (which can be achieved by manually switching the TAPE 2 switch on), the function is determined as follows.

From step 1, pin 3 of Q17 is switched to L level due to

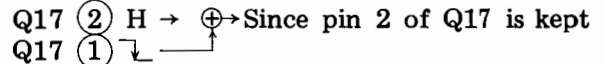

Since pin 2 of Q17 is kept constantly at H level, there is no change at the pin 3 output of Q17. That is, the TAPE 2 function position remains unchanged.

Automatic stopping of Tape Deck and Record Player (see Fig. 8-11)

The signal generated when a function is selected results in the generation of an H level pulse signal from pin 21 of the function switch Q2 (LC7815), thereby turning Q18 on. The audio component operating in playback mode at that time is consequently stopped. (See the block diagram for details of the signal waveform).

Synchronized Tape Deck Start (see Fig. 8-11)

If the tape deck connected to the TAPE 2/ADPT terminals is put into pause mode, and the turntable started by automatic switching, an L level signal appears at the TAPE 2/ADPT terminals. The tape deck pause release circuit is thereby activated for start of tape transport.

9. ELECTRICAL PARTS LIST

NOTES:

- When ordering resistors, first convert resistance values into code form as shown in the following examples.

Ex. 1 When there are 2 effective digits (any digit apart from 0), such as 560 ohm and 47k ohm (tolerance is shown by J = 5%, and K = 10%).

560Ω	56 × 10 ¹	561	RD½PS	561J
47kΩ	47 × 10 ³	473	RD½PS	473J
0.5Ω	0R5	RN2H	0R5K
1Ω	010	RS1P	010K

Ex. 2 When there are 3 effective digits (such as in high precision metal film resistors).

5.62kΩ	562 × 100	5621	RN¼SR	5621F
--------	-----------	------	-------	-------	-------

- The  mark found on some component parts indicates the importance of the safety factor of the part. Therefore, when replacing, be sure to use parts of identical designation.
- For your Parts Stock Control, the fast moving items are indicated with the marks **★★** and **★**.
★★ GENERALLY MOVES FASTER THAN ★.
 This classification shall be adjusted by each distributor because it depends on model number, temperature, humidity, etc.







Miscellaneous Parts

P.C. BOARD ASSEMBLIES

Mark	Part No.	Symbol & Description
	GWP-117	Control assembly A
	GWM-254	Complex assembly

Mark	Part No.	Symbol & Description
★★	2SA1115	Q203
★	US1035 (1S1555)	D201-D208
★	KZL056	D209, D210
★	AEL-404	D211 LED (RED)
★	AEL-370	D212-D215 LED (GREEN)
★	KZL-130	D216, D217

OTHERS

Mark	Part No.	Symbol & Description
 ★	ATT-962	T1 Power transformer (120V)
 ★★	AEK-125	FU1 Fuse (4A)
 ★★	ASG-541	S101 Push switch (POWER)
 △	ACG-017	C101, C103 Ceramic capacitor (0.01/AC125V)
	CKDYF 473Z 50	C102 Capacitor
★★	2SC2922/A/-Y* (2SC2922/A/-P)* (2SC2922/A/-G)*	Q1, Q2 Transistor
★★	2SA1216/A/-Y* (2SA1216/A/-P)* (2SA1216/A/-G)*	Q3, Q4 Transistor
* hfe of Q1-Q4 should have the same value.		
 △	AKP-501	AC socket (AC OUTLETS)
	AEC-942	Sheet (For power transistor)
	AEC-841	Mica wafer
 △	ADG-052	AC power cord
	AAV-308	LED level meter module (VOLUME)
	AAV-310	LED level meter module (TONE)

SWITCHES

Mark	Part No.	Symbol & Description
★★	ASH-301	S201, S202 Slide switch (BASS, TREBLE indicator)
★★	SEAV4S	S203 Push switch (LOUDNESS)
★★	ASG-707	S204, S205 Tact switch (VOLUME UP, DOWN)
★★	ASG-704	S206-S210 Tact switch (PHONO, TUNER, AUX, TAPE1, TAPE2)

CAPACITORS

Mark	Part No.	Symbol & Description
	CQMA 122K 50	C201, C202
	CQMA 562K 50	C209, C210
	CQMA 273K 50	C205, C206
	CQMA 183K 50	C213, C214
	CQMLA 124K 50	C207, C208
	CEJA 2R2M 50	C215
	CEJA 100M 16	C216-C219
	CCDSL 270J 50	C203, C204
	CCDSL 680J 50	C211, C212

COMPLEX ASSEMBLY A

Control Assembly (GWP-117)

SEMICONDUCTORS

Mark	Part No.	Symbol & Description
★★	M54562P	Q201
★★	2SC2603	Q202, Q204

RESISTORS

Note: When ordering resistors, convert the resistance value into code form, and then rewrite the part no. as before.

Mark	Part No.	Symbol & Description
★	ACX-114	VR1, VR2 Slide resistor (TREBLE, BASS)
★	ACX-115	VR3 Slide resistor (MIC MIXING)
	ACT-157	VR4 Variable resistor (BALANCE)
	RD ¼ PM □□□ J	R223–R232, R257–R261
	RD 1/8 PM □□□ J	R201–R222, R233–R246, R262–R282, R291, R292

Volume Assembly

CAPACITORS

Mark	Part No.	Symbol & Description
	CEANP 101M 10	C222
	CKDYF 103Z 50	C231
	CKDYF 473Z 50	C220, C221

RESISTORS

Note: When ordering resistors, convert the resistance value into code form, and then rewrite the part no. as before.

Mark	Part No.	Symbol & Description
★	ACX-502	VR5 Variable resistor with motor
	RD 1/8 PM 123J	R248
	RD 1/8 PM 153J	R248

Jack Assembly

OTHERS

Mark	Part No.	Symbol & Description
	AKN-049	Headphone jack
	AKN-052	MIC jack

Driver Assembly

SEMICONDUCTORS

Mark	Part No.	Symbol & Description
★★	2SA995	Q205, Q206
★★	2SC2259	Q207, Q208
★★	2SA1145/A/	Q209, Q210

CAPACITORS

Mark	Part No.	Symbol & Description
	CEA 101M 10L	C229, C230
	CCDSL 100K 500	C227, C228
	CCDSL 470J 50	C223, C224
	CKDYB 331K 50	C225, C226

RESISTORS

Note: When ordering resistors, convert the resistance value into code form, and then rewrite the part no. as before.

Mark	Part No.	Symbol & Description
	RFA ¼ PS 101J	R283, R284
	RD ¼ PM □□□ J	R249–R252
	RD 1/8 PM 102J	R253–R256

COMPLEX ASSEMBLY B

Complex Assembly (GWM-254)

SEMICONDUCTORS

Mark	Part No.	Symbol & Description
★★	NJM2043DD	Q1
★★	LC7815	Q2
★★	μPD4066BC (TC4066BP)	Q3, Q4
★★	NJM4558DXC (μPC4558C-P)	Q5
★★	2SA968-O* (2SA968-Y)*	Q6, Q7
★★	2SC2238-O* (2SC2238-Y)*	Q8, Q9
	* hfe of Q6–Q9 should have the same value.	
★★	2SC2705	Q10, Q11
★★	2SC2603	Q12, Q13
★★	2SD438/A/-F	Q14
★★	2SD836A	Q15
★★	2SB750A	Q16
★	STV4H-G	D1, D2
★	1S1554	D3–D8
★	KZL140	D9
★	KZL130	D10
★	KZL083	D11, D12
⚠	★ 10E2	D13, D30
⚠	★ S4VB20F	D14
★	10E2FD	D29
★	US1035 (1S1555)	D31–D34

CAPACITORS

Mark	Part No.	Symbol & Description
	ACG-024	C17, C18 Ceramic capacitor (0.1μF)
	ACH-244	C63, C64 Electric capacitor (5600/50V)
	ACG-501	C68 Ceramic capacitor (0.01/AC250V)
	ACH-366	C55 Electric capacitor (47/63V)

Mark	Part No.	Symbol & Description
	CEANL 2R2M 50	C1, C2, C21, C27, C28
	CEANL 470M 16	C5, C6
	CEANL 010M 50	C23, C30
	CEANL 010M 50	C20
	CEA 221M 63L	C77, C78
	CEA 220M 25L	C100
	CQMLA 104K 50	C41—C44
	CEANP R47M 50	C16, C19, C45, C46
	CEJANL 010M 50	C29
	CEA 100M 16L	C13
	CEA 220M 25L	C31, C32, C50, C51, C57—C60
	CEA 100M 100L	C65, C66
	CEA 470M 50L	C33, C34
	CEA 471M 6L	C47
	CEA 2R2M 50L	C11, C12, C24
	CEA 470M 63L	C56
	CEA R47M 100L	C49
	ACH-365	C48 (100/25V)
	CQMA 822J 50	C9, C10
	CQMA 222J 50	C7, C8
	CQMA 473K 50	C37, C38
	CQMA 393J 50	C22
	CCDSL 470J 50	C25, C26
	CCDSL 151K 500	C35, C36, C39, C40
	CKDYB 222K 50	C61, C62
	CKDYF 103Z 50	C14
	CCDSL 181J 50	C3, C4
	ACG-019	C67 Ceramic capacitor (0.01/150V)
	CKDYB 472K 50	C15
	CEA 010M 50L	C84

RESISTORS

Note: When ordering resistors, convert the resistance value into code form, and then rewrite the part no. as before.

Mark	Part No.	Symbol & Description
	ACN-131	R71—R74 Wire wound
	RS1L □□□ J	R85, R86, R90, R91, R103
△	RD ¼ PMFL 101J	R93, R94
△	RD ¼ PMF 4R7J	R101, R102
△	RD ¼ PSF 2R2J	R99, R100
△	RFA ¼ PS □□□ J	R61—R70, R79, R80, R83, R84, R87, R104, R118—R121
	RD ¼ PM □□□ J	R57—R60, R75—R78, R92
	RD 1/8 PM □□□ J	Others resistor

OTHERS

Mark	Part No.	Symbol & Description
★★	ASR-105	RL1 Relay
	AKB-094	Terminal 4P (TAPE1, TAPE2/ADAPTOR)
	AKB-095	Terminal 6P (INPUT)
	AKE-107	Terminal (SPEAKERS)
	ATH-053	L1, L2 AF choke coil
	AKH-017	Transistor socket
	VBZ30P080FMC	Screw 3 x 8

Control Assembly

SEMICONDUCTORS

Mark	Part No.	Symbol & Description
★★	μPD4001BC (TC4001BP)	Q17
★★	2SC2603	Q18
★★	2SA1115	Q19
★	US1035 (1S1555)	D15—D28

SWITCHES

Mark	Part No.	Symbol & Description
★★	ASH-031	S1, S2 Slide switch (TAPE DECK SELECTOR)

CAPACITORS

Mark	Part No.	Symbol & Description
	CKDYX 104M 25	C82
	CEA 100M 16L	C69
	CEA 3R3M 50L	C70—C72
	ACG-024	C80, C81, C83 Ceramic capacitor

RESISTORS

Note: When ordering resistors, convert the resistance value into code form, and then rewrite the part no. as before.

Mark	Part No.	Symbol & Description
	RD 1/8 PM □□□ J	R105—R117

OTHERS

Mark	Part No.	Symbol & Description
	AKN-202	Mini jack (AUTO FUNCTION)

Socket Assembly A

OTHERS

Mark	Part No.	Symbol & Description
	AKH-009	Transistor socket
	CKDYB 222K 50	C52

Socket Assembly B

OTHERS

Mark	Part No.	Symbol & Description
	AKH-009	Transistor socket
	CKDYB 222K 50	C54

Socket Assembly C

OTHERS

Mark	Part No.	Symbol & Description
	AKH-009	Transistor socket
	CKDYB 222K 50	C53

10. PACKING

Mark	No.	Part No.	Description
	1.	ARB-536	Operating instructions (English)
	2.	AHE-125	Packing case
	3.	AHA-324	Front pad
	4.	AHA-325	Rear pad
	5.		Vinyl bag
	6.		Sheet

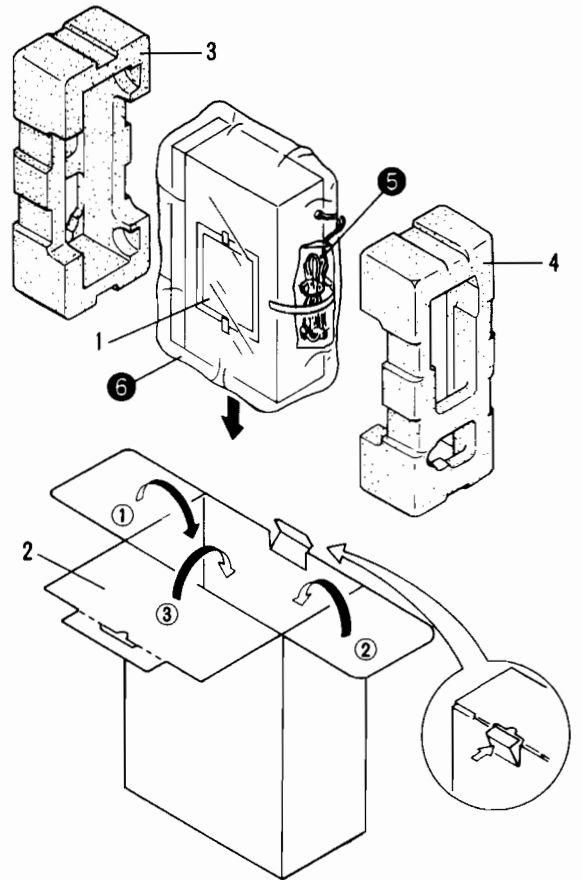

11. FOR NE, YB, S/G AND S TYPES

11.1 CONTRAST PARTS

A-X7/NE, YB, S and S/G types are the same as the A-X7/KU type except for following sections.

MISCELLANEOUS PARTS

Mark	Symbol & Description	Part No.				Remarks
		KU type	NE type	YB type	S, S/G types	
	Complex assembly	GWM-254	GWM-278	GWM-278	GWM-254	
⚠ ★	T1 Power transformer (120V)	ATT-962	
⚠ ★	T1 Power transformer (220V/240V)	ATT-952	ATT-952	
⚠ ★	T1 Power transformer (110V, 120V, 220V, 240V)	ATT-963	
⚠ ★★	FU1 Fuse (4A)	AEK-125	
⚠ ★★	FU1 Fuse (T1.5A)	AEK-018	AEK-018	
⚠ ★★	FU2 Fuse (T2.5A)	AEK-403	AEK-403	
⚠ ★★	FU1, FU2 Fuse (2A)	AEK-122	
⚠ ★★	S101 Push switch (POWER)	ASG-541	ASG-542	ASG-542	ASG-541	
⚠	C101, C103 Ceramic capacitor (0.01/AC125V)	ACG-017	
⚠	C101 Ceramic capacitor (0.01/AC250V)	ACG-501	ACG-001	
⚠	AC socket (AC OUTLETS)	AKP-501	AKP-502	AKP-505	AKP-501	
	Nylon rivet (for PVC sheet)	AEC-558	AEC-558	
	PVC sheet	Non supply	Non supply	
	Strain relief	AEC-327	
	Rivet S	ABM-002	
⚠	AC power cord	ADG-052	ADG-068	ADG-063	ADG-060	
	Line voltage selector switch	AKX-063	
	Bonnet case	ANE-411	ANE-397	ANE-397	ANE-397	
	Operating instructions (English)	ARB-536	ARB-523	ARB-523	
	Operating instructions (English/German/French/Italian)	ARE-055	
	Operating instructions (spanish)	ARC-032	(S type only)

LINE VOLTAGE SELECTION (FOR NE, YB, TYPES)

Line voltage can be changed as follows:

1. Disconnect the AC power cord.
2. Remove the bonnet case.
3. Change the connection of the power transformer primary tape.
4. Stick the line voltage label on the rear panel.

Description	Part No.
220V label	AAX-193
240V label	AAX-192

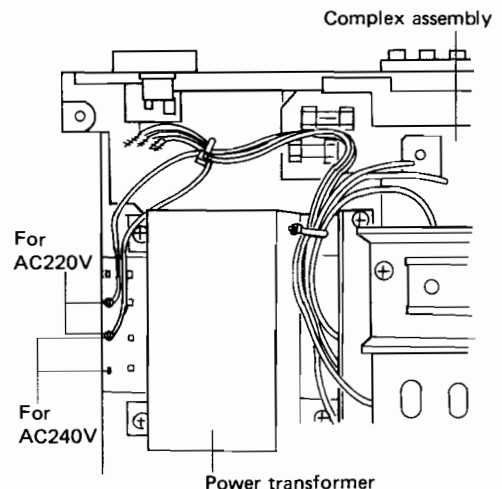

4

5

6

7

8

9

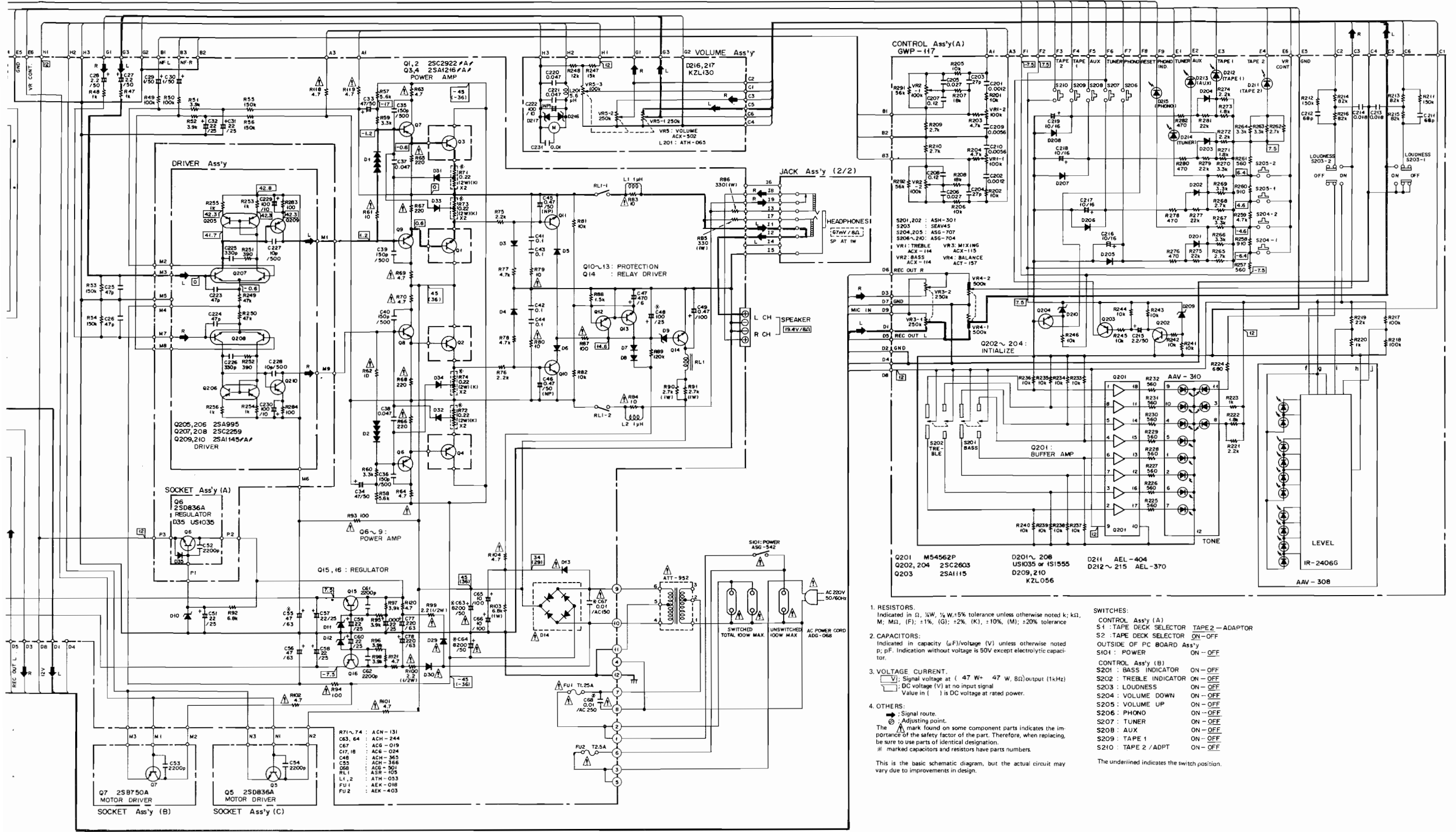

A

B

C

D

4

5

6

7

8

9

For NE and YB types

COMPLEX ASSEMBLY (GWM-278)

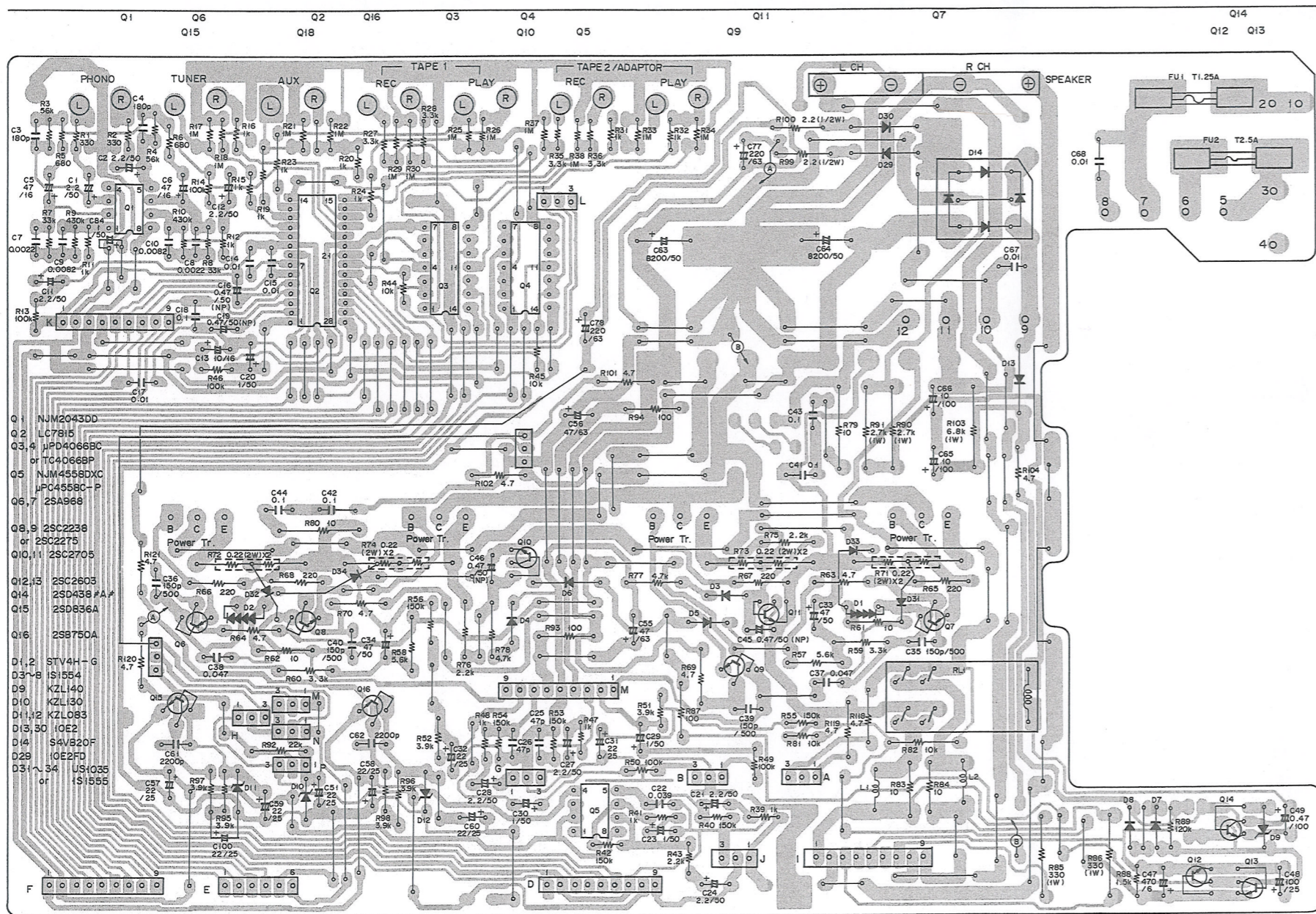

For YB type

POWER SUPPLY CIRCUIT

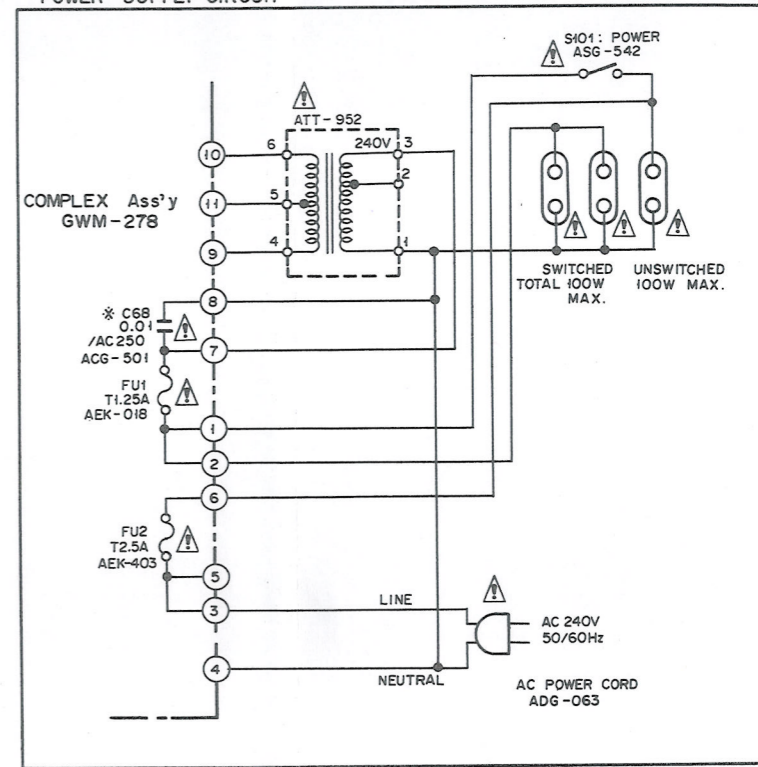

For S, S/G type

POWER SUPPLY CIRCUIT

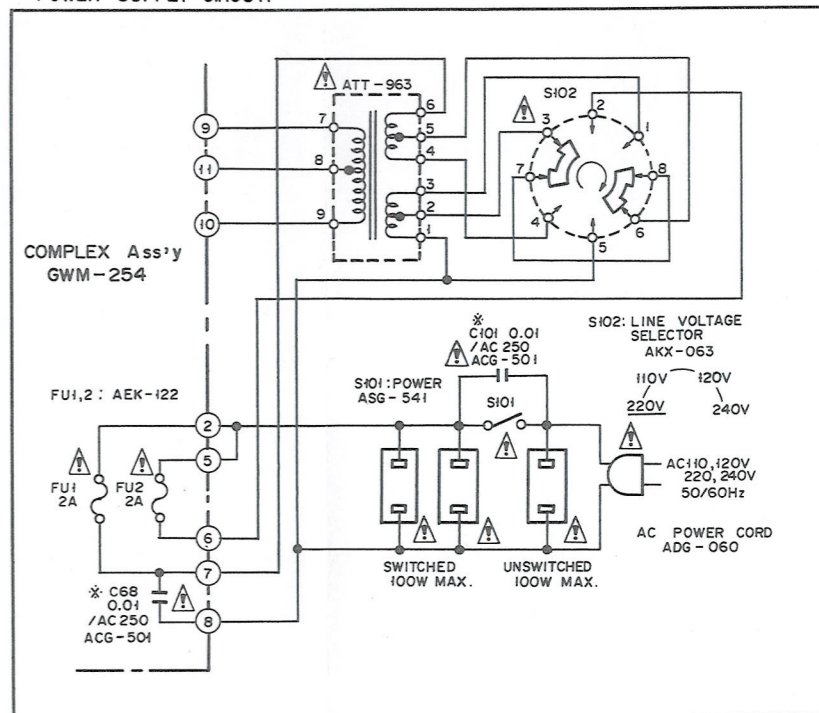

11.3 ELE

NOTES:

- When on the follo
- Ex. 1 Wl
- an
- 56
- 47
- 0.3
- 15
- Ex. 2 Wl
- to
- 5.1
- The safety fa
- designati
- For you
- ★ ★ GEN
- This clas
- number,

COMPLE

Complex /

SEMICOND

Mark Par

- ★ ★ NJ
- ★ ★ LC
- ★ ★ μP
- (TC
- ★ ★ NJ
- (μP
- ★ ★ 2S/
- (2S
- ★ ★ 2S/
- (2S
- * I
- ★ ★ 2S/
- ★ ★ 2S/
- ★ ★ 2S/
- ★ ★ 2S/
- ★ ★ 2S/
- ★ ST
- ★ 1S
- ★ K2
- ★ K2
- ★ K2
- ★ 10
- ★ S4
- ★ 10
- ★ US
- ★ (1:

For YB type

POWER SUPPLY CIRCUIT

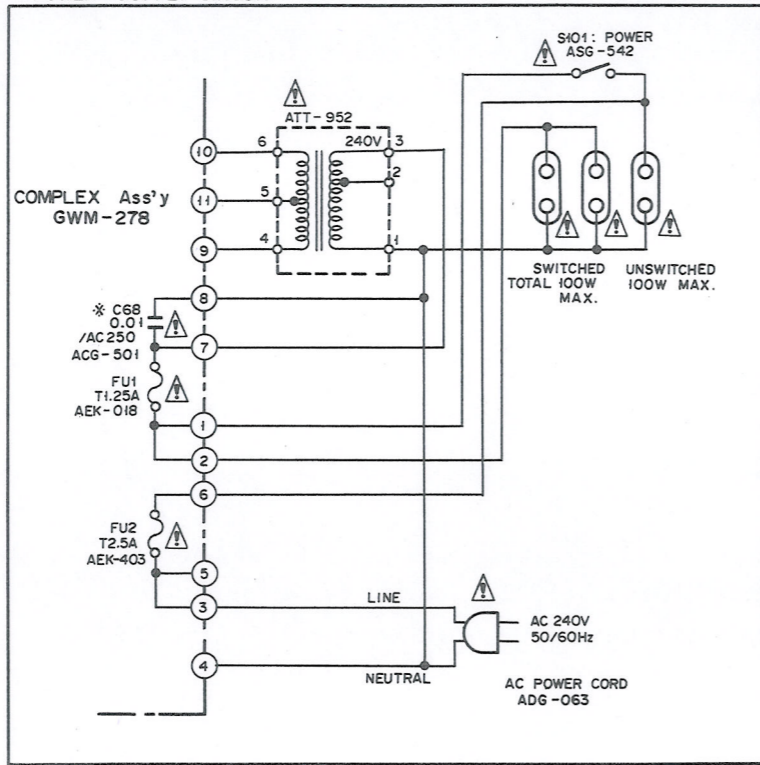

For S, S/G type

POWER SUPPLY CIRCUIT

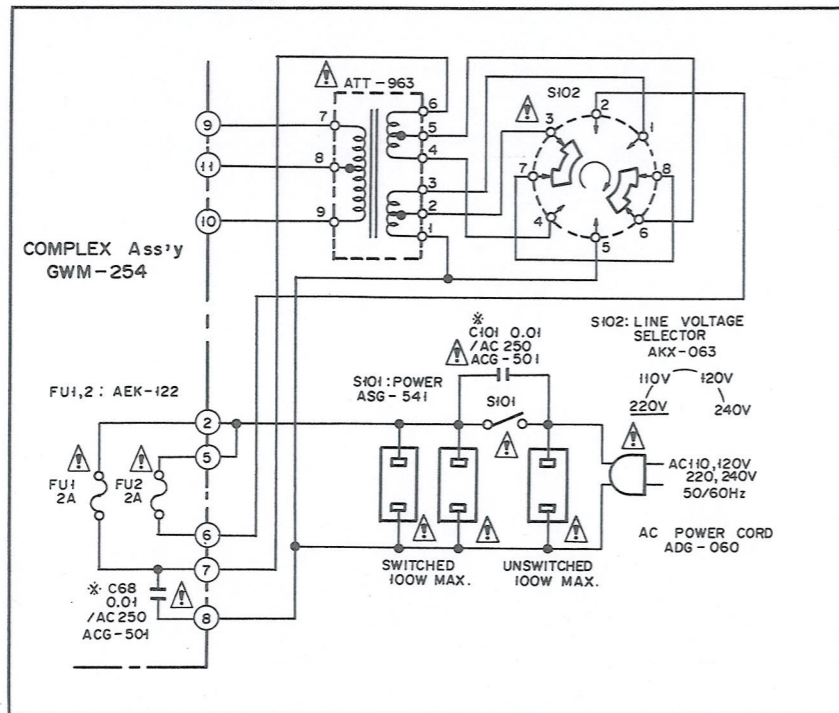

11.3 ELECTRICAL PARTS LIST

NOTES:

When ordering resistors, first convert resistance values into code form as shown in the following examples.

Ex. 1 When there are 2 effective digits (any digit apart from 0), such as 560 ohm and 47k ohm (tolerance is shown by J = 5%, and K = 10%).

560Ω	56 × 10 ¹	561	RD¼PS	561J
47kΩ	47 × 10 ³	473	RD¼PS	473J
0.5Ω	0R5		RN2H	0R5K
1Ω	010		RS1P	010K

Ex. 2 When there are 3 effective digits (such as in high precision metal film resistors).

5.62kΩ	562 × 100	5621	RN¼SR	5621F
--------	-----------	------	-------	-------

The Δ mark found on some component parts indicates the importance of the safety factor of the part. Therefore, when replacing, be sure to use parts of identical designation.

For your Parts Stock Control, the fast moving items are indicated with the marks ****** and *****.

****** GENERALLY MOVES FASTER THAN *****.

This classification shall be adjusted by each distributor because it depends on model number, temperature, humidity, etc.

COMPLEX ASSEMBLY B

Complex Assembly (GWM-278)

SEMICONDUCTORS

Mark	Part No.	Symbol & Description
**	NJM2043DD	Q1
**	LC7815	Q2
**	μPD4066BC (TC4066BP)	Q3, Q4
**	NJM4558DXC (μPC4558C-P)	Q5
**	2SA968-O* (2SA968-Y)*	Q6, Q7
**	2SC2238-O* (2SC2238-Y)*	Q8, Q9
* hfe of Q6-Q9 should have the same value.		
**	2SC2705	Q10, Q11
**	2SC2603	Q12, Q13
**	2SD438/A/	Q14
**	2SD836A	Q15
**	2SB750A	Q16
*	STV4H-G	D1, D2
*	1S1554	D3-D8
*	KZL140	D9
*	KZL130	D10
*	KZL083	D11, D12

CAPACITORS

Mark	Part No.	Symbol & Description
	ACG-024	C17, C18 Ceramic capacitor (0.1/25V)
	ACH-257	C63, C64 Electric capacitor (100/50V)
	ACG-501	C68 Electric capacitor (0.01/AC250V)
	ACH-366	C55 Electric capacitor (47/63V)
	CEANL 2R2M 50	C1, C2, C21, C27, C28
	CEANL 470M 16	C5, C6
	CEANL 010M 50	C20, C23, C30
	CEA 221M 63L	C77, C78
	CEA 220M 25L	C100
	CQMLA 104K 50	C41-C44
	CEANP R47M 50	C16, C19, C45, C46
	CEJANL 010M 50	C29
	CEA 100M 16L	C13
	CEA 220M 25L	C31, C32, C51, C57-C60
	CEA 100M 100L	C65, C66
	CEA 470M 50L	C33, C34
	CEA 471M 6L	C47
	CEA 2R2M 50L	C11, C12, C24
	CEA 470M 63L	C56
	CEA R47M 100L	C49
	ACH-365	C48 (100/25V)
	CQMA 822J 50	C9, C10
	CQMA 222J 50	C7, C8
	CQMA 473K 50	C37, C38
	CQMA 393J 50	C22

Mark	Part No.	Symbol & Description
*	10E2	D13, D30
*	S4VB20F	D14
*	10E2FD	D29
*	US1035	D31-D34
*	(1S1555)	

Mark	Part No.	Symbol & Description
	CCDSL 470J 50	C25, C26
	CCDSL 151K 500	C35, C36, C39, C40
	CKDYB 222K 50	C61, C62
	CKDYF 103Z 50	C14
	CCDSL 181J 50	C3, C4
	CKDYB 472K 50	C15
	ACG-019	C67 Ceramic capacitor (0.01/150V)
	ACG-024	C17 (0.1/25V)

RESISTORS

Note: When ordering resistors, convert the resistance value into code form, and then rewrite the part no. as before.

Mark	Part No.	Symbol & Description
	ACN-131	R71–R74 Wire wound
	RS1L □□□J	R85, R86, R90, R91, R103
⚠	RD ½ PSF 2R2J	R99, R100
⚠	RFA ¼ PS □□□J	R61–R70, R79, R80, R83, R84, R87, R93, R94, R104, R118– R121
	RD ¼ PMF 4R7J	R101, R102
	RD ¼ PM □□□J	R57–R60, R75–R78, R92
	RD 1/8 PM □□□J	Others resistor

OTHERS

Mark	Part No.	Symbol & Description
★★	ASR-105	RL1 Relay
	AKB-094	Terminal 4P (TAPE1, TAPE2/ ADAPTOR)
	AKB-095	Terminal 6P (INPUT)
	AKE-107	Terminal (SPEAKERS)
	AKH-017	Transistor socket
	VBZ30P080FMC	Screw 3 x 8

Control Assembly B

SEMICONDUCTORS

Mark	Part No.	Symbol & Description
★★	μPD4001BC (TC4001BP)	Q17
★★	2SC2603	Q18
★★	2SA1115	Q19
★	US1035 (1S1555)	D15–D28

SWITCHES

Mark	Part No.	Symbol & Description
★★	ASH-031	S1, S2 Slide switch (TAPE DECK SELECTOR)

CAPACITORS

Mark	Part No.	Symbol & Description
	CKDYX 104M 25	C82
	CEA 100M 16L	C69
	CEA 3R3M 50L	C70–C72
	ACG-024	C80, C81, C83 Ceramic capacitor (0.1/25V)

RESISTORS

Note: When ordering resistors, convert the resistance value into code form, and then rewrite the part no. as before.

Mark	Part No.	Symbol & Description
	RD 1/8 PM □□□J	R105–R117

OTHERS

Mark	Part No.	Symbol & Description
	AKN-202	Mini jack (AUTO FUNCTION)

Socket Assembly A

OTHERS

Mark	Part No.	Symbol & Description
	AKH-009	Transistor socket
	CKDYB 222K 50	C52

Socket Assembly B

OTHERS

Mark	Part No.	Symbol & Description
	AKH-009	Transistor socket
	CKDYB 222K 50	C54

Socket Assembly C

OTHERS

Mark	Part No.	Symbol & Description
	AKH-009	Transistor socket
	CKDYB 222K 50	C53
★	US1035	D35 Diode

11.4 SPECIFICATIONS

The specifications for A-X7/NE, YB, S and S/G types are the same as the A-X7/KU type except for following sections.

Miscellaneous

Power Requirements

NE type	AC220V, 50/60Hz
YB type	AC240V, 50/60Hz
S, S/G types	AC110V, 120V, 220V and 240V, 50/60Hz

Power Consumptions

NE, YB types	310W (MAX.)
S, S/G types	105W

ADDITIONAL



Service Manual

ORDER NO.
ARP-290-0

STEREO AMPLIFIER

A-X7

NEZ

- This additional service manual is applicable to the A-X7/NEZ type.
- The basic performance of the A-X7/NEZ type is the same as the A-X7/KU type. Please refer to the A-X7/KU type service manual (ARP-224) with the exception of this additional service manual.

SPECIFICATIONS

Amplifier Section

DIN, Continuous Power Output at 1kHz
(both channels driven)

T. H. D. 1%, 8 ohms 55 watts per channel
 Total Harmonic Distortion (20 Hertz to 20,000 Hertz,
 8 ohms, from AUX)
 continuous rated power output . . . No more than 0.07%
 30 watts per channel power output
 No more than 0.07%

Damping Factor 1,000 Hertz, 8 ohms) 35
Input (Sensitivity/Impedance)

PHONO 2.5 mV/50 kilohms
 TUNER, AUX, TAPE PLAY, ADAPTOR IN
 150mV/50 kilohms
 MIC 1 mV/5 kilohms

Phono Overload Level (T. H. D. 0.1%, 1,000 Hz)
 PHONO 60mV

Output (Level/Impedance)
 TAPE REC, ADAPTOR OUT 150mV
 Speaker 6 ~ 16Ω

Frequency Response
 PHONO (RIAA Equalization)
 20 Hz to 20,000 Hz ±0.3dB
 TUNER, AUX, TAPE PLAY, ADAPTOR
 20 Hz to 40,000 Hz $\begin{matrix} +1 \\ -3 \end{matrix}$ dB

Tone Control

BASS ±10 dB (100 Hz)
 TREBLE ±10 dB (10 kHz)
 Loudness Contour (Volume control set at -40 dB position)
 +8 dB (100 Hz), +4 dB (10 kHz)
 Hum and Noise (IHF, short-circuited A network)
 PHONO 76 dB
 TUNER, AUX, TAPE PLAY, ADAPTOR IN . . . 98 dB
 Hum and Noise (DIN, continuous Power/50 mW)
 PHONO 70 dB/60 dB
 TUNER, AUX, TAPE PLAY, ADAPTOR IN
 82 dB/62 dB

Miscellaneous

Power Requirements a.c. 220 volts ~ 50/60 Hz
 Power Consumption 310 watts (max.)
 Dimensions 320 (W) x 98 (H) x 222 (D) mm
 12-5/8 (W) x 3-7/8 (H) x 8-3/4 (D) in
 Weight (without package) 5.6 kg (12 lb 5 oz)

Furnished Parts

Operating Instructions 1

NOTE:

Specifications and design subject to possible modification without notice.

PIONEER ELECTRONIC CORPORATION 4-1, Meguro 1-Chome, Meguro-ku, Tokyo 153, Japan
PIONEER ELECTRONICS (USA) INC. 1925 E. Dominguez St., Long Beach, California 90810 U.S.A.
PIONEER ELECTRONIC (EUROPE) N.V. Keetberglaan 1, 2740 Beveren, Belgium
PIONEER ELECTRONICS AUSTRALIA PTY. LTD. 178-184 Boundary Road, Braeside, Victoria 3195, Australia

1. CONTRAST OF PARTS

A-X7/NEZ type is the same as the A-X7/KU type except for following sections.

MISCELLANEOUS PARTS

Mark	Symbol & Description	Part No.		Remarks
		KU type	NEZ type	
	Complex assembly B	Non supply	Non supply	
△ ★	T1 Power transformer (120V)	ATT-962	
△ ★	T1 Power transformer (220V/240V)	ATT-952	
△ ★★	FU1 Fuse (4A)	AEK-125	
△ ★★	FU1 Fuse (T1.5A)	AEK-018	
△ ★★	FU2 Fuse (T2.5A)	AEK-403	
△ ★★	S101 Push switch (POWER)	ASG-541	ASG-542	
△	AC socket (AC OUTLETS)	AKP-501	AKP-502	
	PVC sheet	Non supply	
△	AC power cord	ADG-073	ADG-068	
	Bonnet case	ANE-411	ANE-397	
	Packing case	AHE-125	AHE-170	
	Operating instructions (English)	ARB-536	
	Operating instructions (German)	ARC-040	

P.C. BOARD ASSEMBLIES (COMPLEX ASSEMBLY B)

Mark	Symbol & Description	Part No.		Remarks
		KU type	NEZ type	
	Complex assembly	GWM-254	GWM-299	
	Control assembly B	Non supply	Non supply	
	Socket assembly A	Non supply	Non supply	
	Socket assembly B	Non supply	Non supply	
	Socket assembly C	Non supply	Non supply	

2. SCHEMATIC DIAGRAM

A

B

C

D

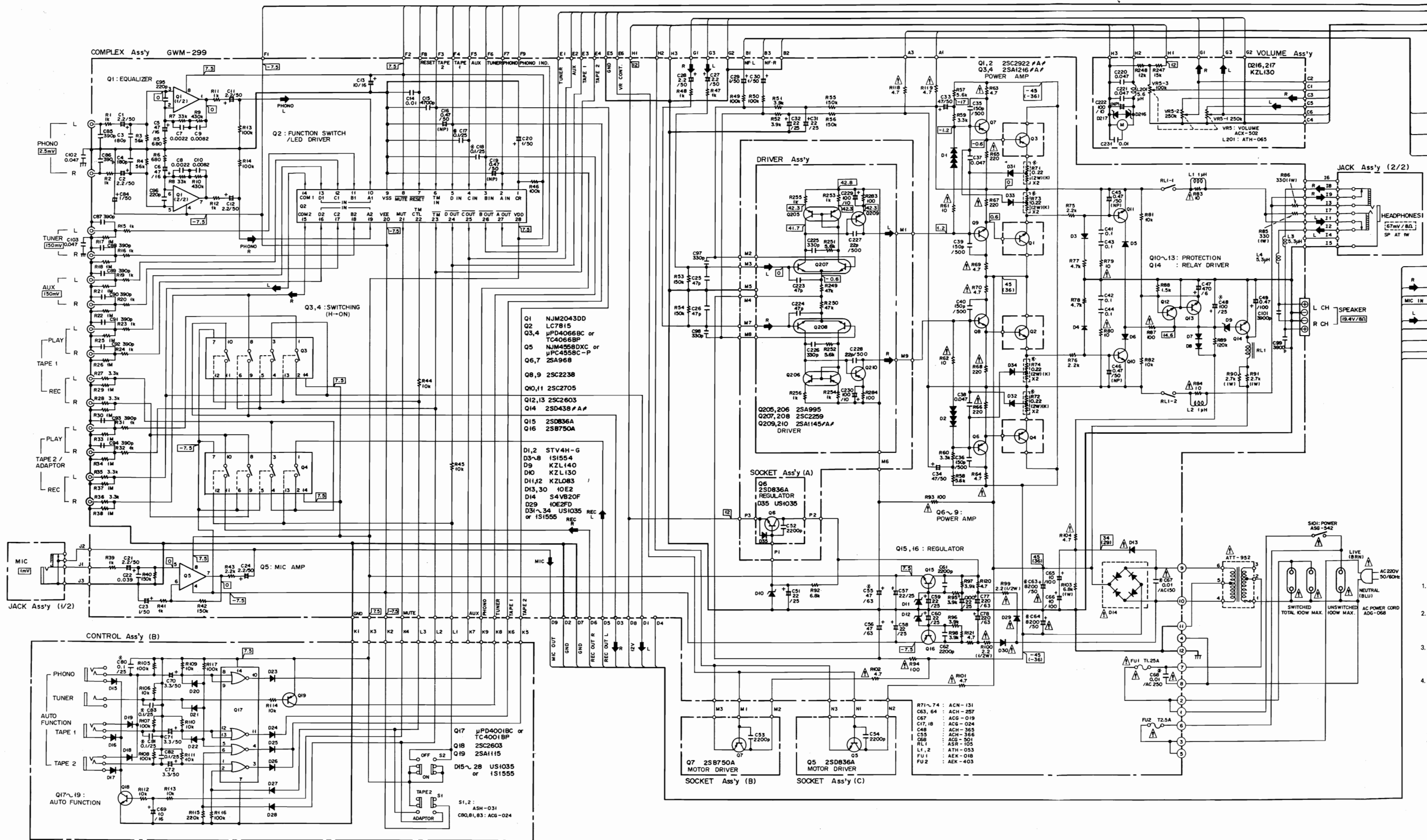

1

2

3

4

5

6

NOTE: The indicated semiconductors are representative ones only. Other alternative semiconductors may be used and are listed in the parts list.

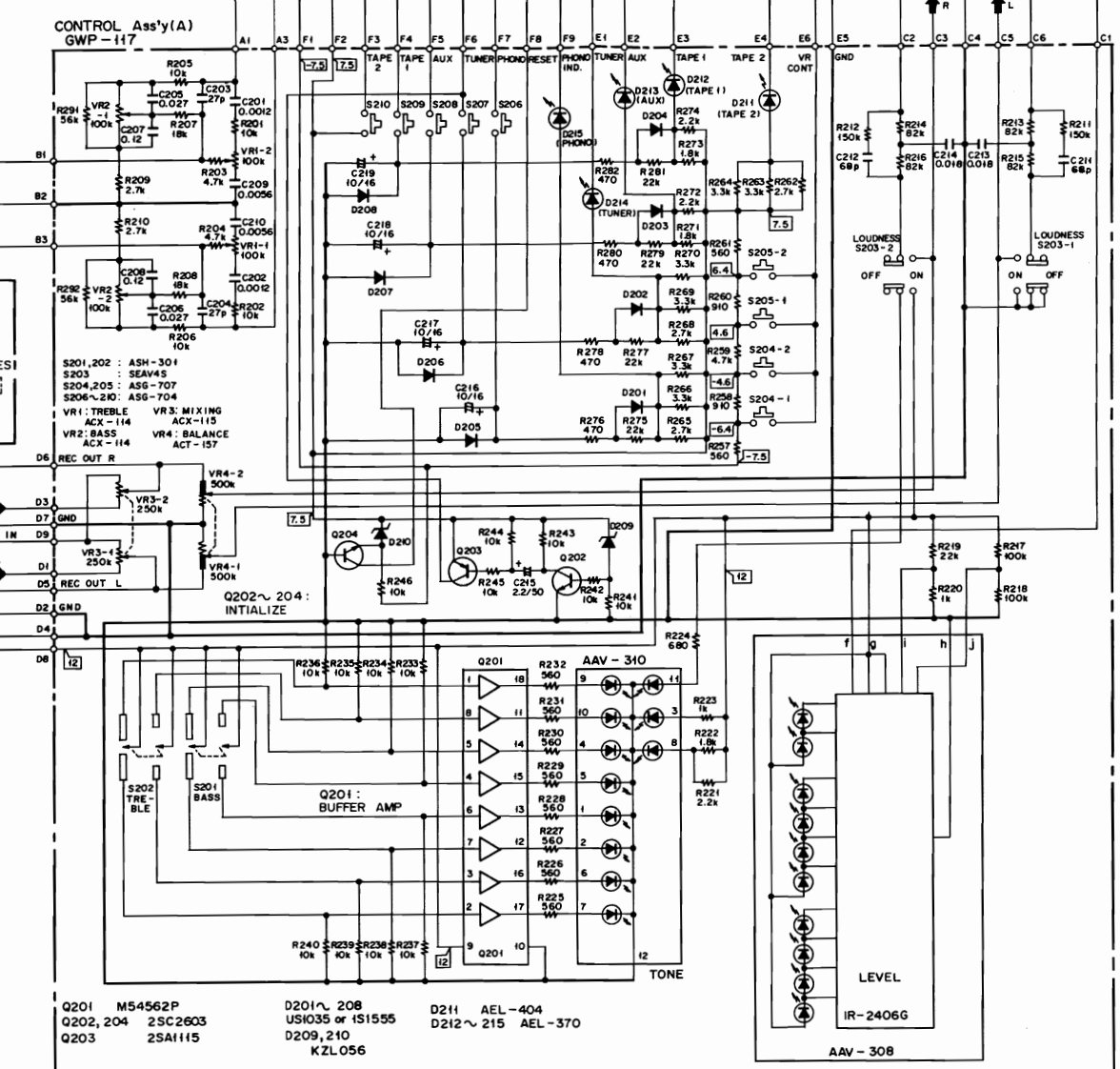
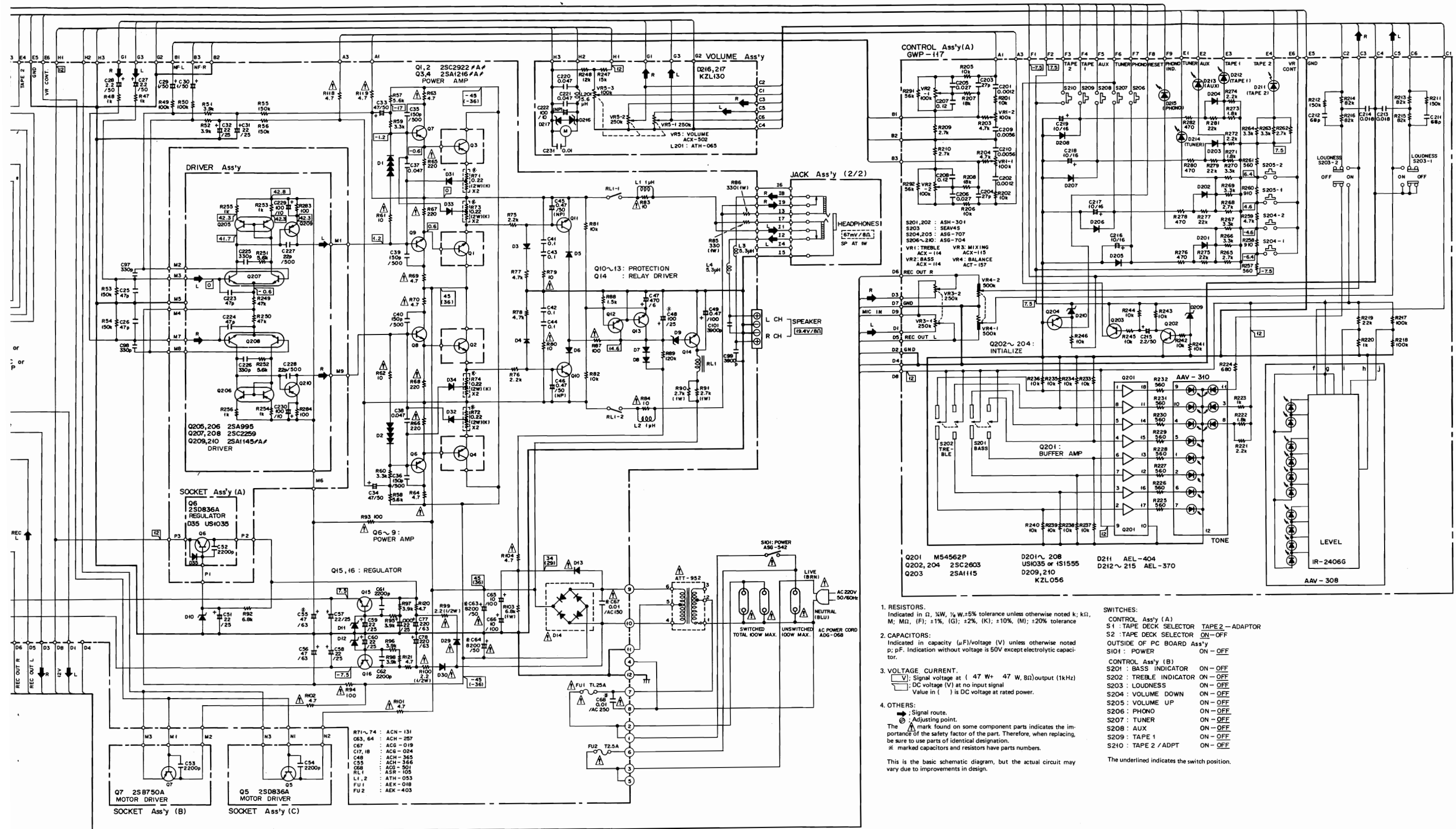

- 1. RESISTORS. Indicated in Ω, ¼W, ½W; ±5% tolerance unless otherwise noted; k; 1k1, M; M1, (F); ±1%, (G); ±2%, (K); ±10%, (M); ±20% tolerance
- 2. CAPACITORS: Indicated in capacity (µF)/voltage (V) unless otherwise noted; p; pF. Indication without voltage is 50V except electrolytic capacitor.
- 3. VOLTAGE, CURRENT. [Symbol] V: Signal voltage at (47 W, 8Ω) output (1kHz) [Symbol] V: DC voltage (V) at no input signal Value in () is DC voltage at rated power.
- 4. OTHERS: [Symbol]: Signal route. [Symbol]: Adjusting point. The [Symbol] mark found on some component parts indicates the importance of the safety factor of the part. Therefore, when replacing, be sure to use parts of identical designation. * marked capacitors and resistors have parts numbers.

- SWITCHES: CONTROL Ass'y (A) S1 : TAPE DECK SELECTOR TAPE2 - ADAPTOR S2 : TAPE DECK SELECTOR ON-OFF OUTSIDE OF PC BOARD Ass'y S101 : POWER ON - OFF CONTROL Ass'y (B) S201 : BASS INDICATOR ON - OFF S202 : TREBLE INDICATOR ON - OFF S203 : LOUDNESS ON - OFF S204 : VOLUME DOWN ON - OFF S205 : VOLUME UP ON - OFF S206 : PHONO ON - OFF S207 : TUNER ON - OFF S208 : AUX ON - OFF S209 : TAPE 1 ON - OFF S210 : TAPE 2 / ADPT ON - OFF

This is the basic schematic diagram, but the actual circuit may vary due to improvements in design.

The underlined indicates the switch position.

A
B
C
D

3. P.C. BOARD PATTERNS

COMPLEX Ass'y (GWM-299)

CONTROL Ass'y (B)

4. ELE

A

B

C

D

A

B

C

D

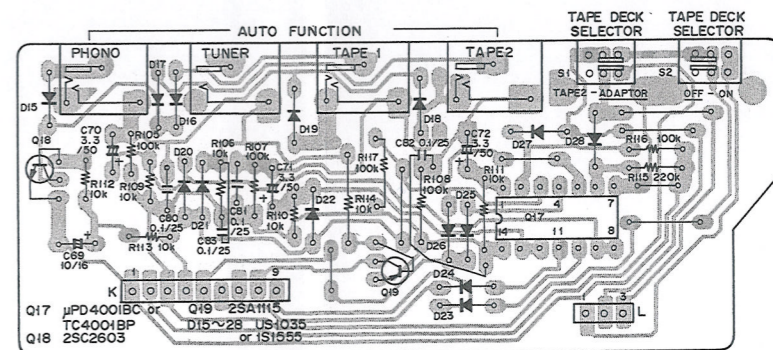
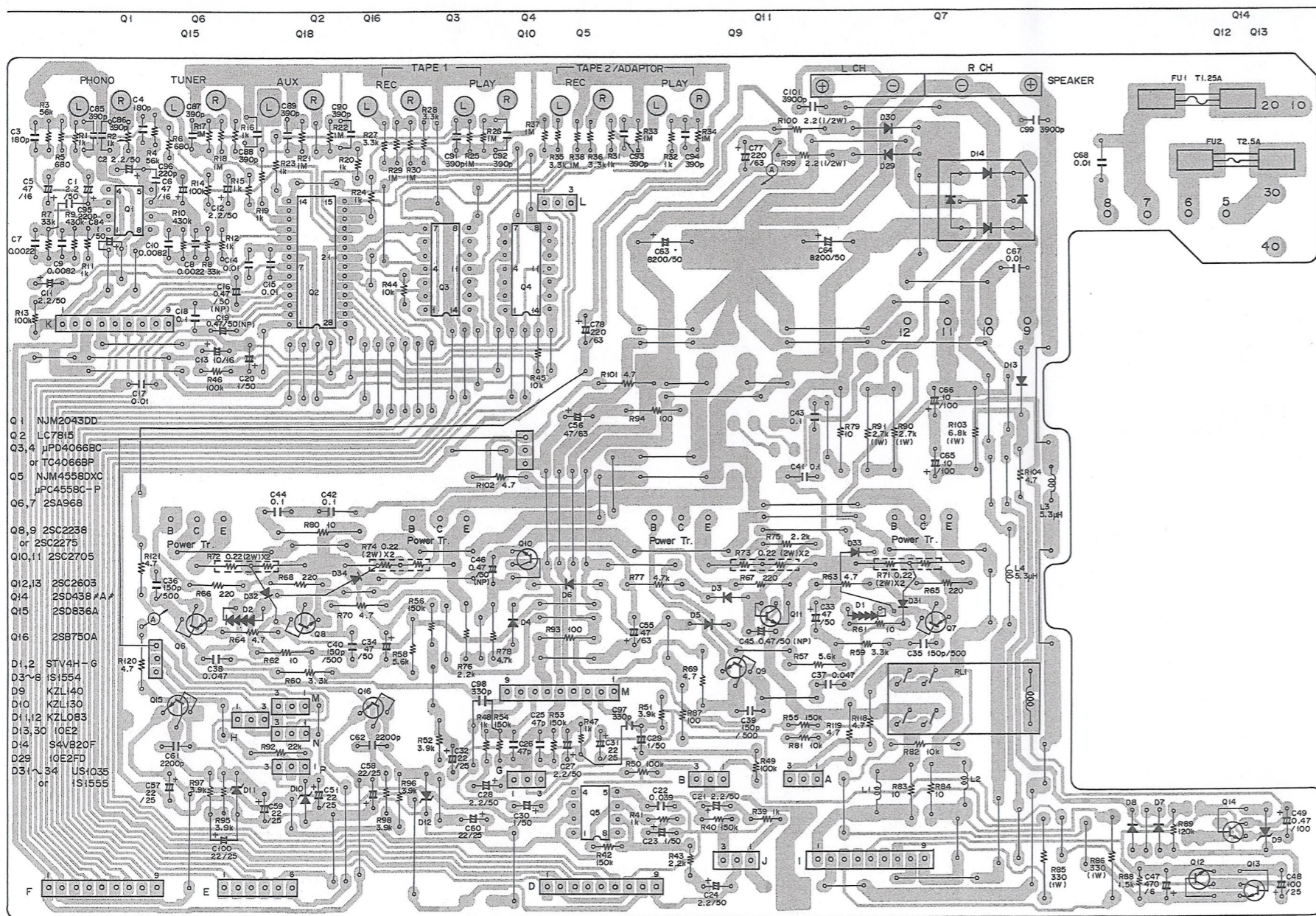

SOCKET Ass'y (A)

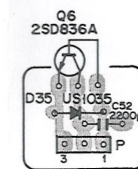

SOCKET Ass'y (B)

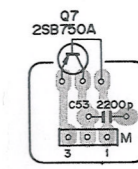

SOCKET Ass'y (C)

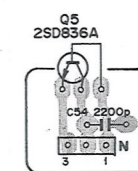

NOTES:

- When order the following:
 Ex. 1 When and 560 47k 0.5Ω
 Ex. 2 When tors 5.6Ω
- The Δ safety fact designation
- For your 1 ★★ and ★. ★★ GENE This class; number, t

COMPLEX Complex A: SEMICONDU

Mark Part I

- ★★ NJM:
- ★★ LC78
- ★★ μPD (TC4)
- ★★ NJM: (μPC
- ★★ *2SA:
- * (2SA
- ★★ *2SC:
- * (2SC
- * hfe
- ★★ 2SC:
- ★★ 2SC:
- ★★ 2SD:
- ★★ 2SD:
- ★★ 2SB:

- ★ STV
- ★ 1S15
- ★ KZL
- ★ KZL
- ★ KXL

- ★ 10E
- ★ S4V
- ★ US1 (1S1

CONTROL Ass'y (B)

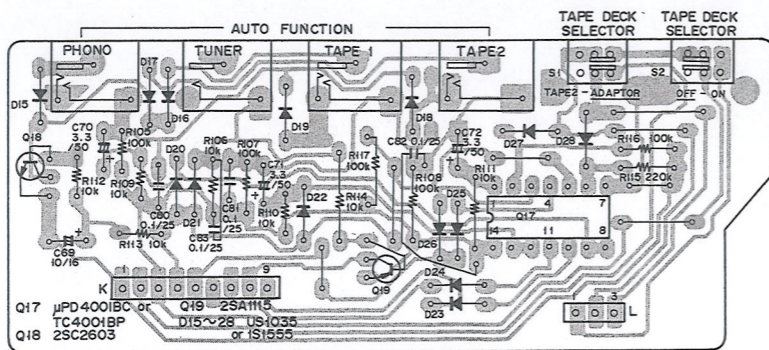

SOCKET Ass'y (A)

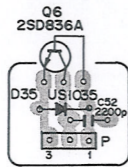

SOCKET Ass'y (B)

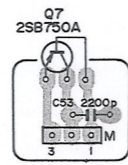

SOCKET Ass'y (C)

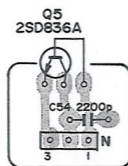

4. ELECTRICAL PARTS LIST

NOTES:

- When ordering resistors, first convert resistance values into code form as shown in the following examples.
 - Ex. 1 When there are 2 effective digits (any digit apart from 0), such as 560 ohm and 47k ohm (tolerance is shown by J = 5%, and K = 10%).
 - 560Ω 56 x 10¹ 561 RD¼PS 561J
 - 47kΩ 47 x 10³ 473 RD¼PS 473J
 - 0.5Ω 0R5 RN2H 0R5K
 - 1Ω 010 RS1P 010K
 - Ex. 2 When there are 3 effective digits (such as in high precision metal film resistors).
 - 5.62kΩ 562 x 100 5621 RN¼SR 5621F
- The Δ mark found on some component parts indicates the importance of the safety factor of the part. Therefore, when replacing, be sure to use parts of identical designation.
- For your Parts Stock Control, the fast moving items are indicated with the marks **★★** and **★**.
 - ★★** GENERALLY MOVES FASTER THAN **★**.
 - This classification shall be adjusted by each distributor because it depends on model number, temperature, humidity, etc.

COMPLEX ASSEMBLY B

Complex Assembly (GWM-299)

SEMICONDUCTORS

Mark	Part No.	Symbol & Description
★★	NJM2043DD	Q1
★★	LC7815	Q2
★★	μPD4066BC (TC4066BP)	Q3, Q4
★★	NJM4558DXC (μPC4558C-P)	Q5
★★	*2SA968-O	Q6, Q7
	*(2SA968-Y)	
★★	*2SC2238-O	Q8, Q9
	*(2SC2238-Y)	
	* hfe of Q6-Q9 should have the same value.	
★★	2SC2705	Q10, Q11
★★	2SC2603	Q12, Q13
★★	2SD438/A/	Q14
★★	2SD836A	Q15
★★	2SB750A	Q16
★	STV4H-G	D1, D2
★	1S1554	D3-D8
★	KZL140	D9
★	KZL130	D10
★	KXL083	D11, D12
Δ	★ 10E2	D13, D29, D30
Δ	★ S4VB20F	D14
	★ US1035 (1S1555)	D31-D34

CAPACITORS

Mark	Part No.	Symbol & Description
	CEANL 2R2M 50	C1, C2, C21, C27, C28
	CEANL 470M 16	C5, C6
	CEANL 010M 50	C23, C30
	CQMLA 104K 50	C41-C44
Δ	ACG-019	C67 Ceramic capacitor (0.01/AC150V)
	CEANP R47M 50	C45, C46
	CEJANL 010M 50	C29
	CEA 100M 16L	C13
	CEA 220M 25L	C31, C32, C51, C57-C60
	CEA 100M 100L	C65, C66
	CEA 470M 50L	C33, C34
	CEA 471M 6L	C47
	CEA 2R2M 50L	C11, C12, C24
	CEA 470M 63L	C56
	CEA R47M 100L	C49
	ACH-365	C48 (100/25V)
	CEANP R47M 50	C16, C19
	CQMA 822J 50	C9, C10
	CQMA 222J 50	C7, C8
	CQMA 473K 50	C37, C38
	CQMA 393J 50	C22
	CCDSL 470J 50	C25, C26
	CCDSL 151K 500	C35, C36, C39, C40
	CKDYB 222K 50	C61, C62
	CKDYF 103Z 50	C14

Mark	Part No.	Symbol & Description
	CCDSL 181J 50	C3, C4
	CKDYB 472K 50	C15
	CKDYB 331K 50	C97, C98
	CKDYB 391K 50	C85-C94
	CKDYB 392K 50	C99, C101
	CCDSL 221J 50	C95, C96
	CEA 010M 50L	C84
⚠	ACH-257	C63, C64 Electrolytic capacitor (8200/50V)
⚠	ACG-501	C68 Ceramic capacitor (0.01/AC250V)
	ACG-024	C17, C18 Ceramic capacitor (0.1/25V)
	CEANL 010M 50	C20
	ACH-366	C55 Electrolytic capacitor (47/63V)
	CEA 221M 63L	C77, C78
	CEA 220M 25L	C100

RESISTORS

Note: When ordering resistors, convert the resistance value into code form, and then rewrite the part no. as before.

Mark	Part No.	Symbol & Description
⚠	RFA¼PS □□□J	R61-R70, R79, R80, R83, R84, R87, R93, R94, R104, R118- R121
⚠	RD¼PSF2R2J	R99, R100
⚠	RD¼PMF4R7J	R101, R102
	RS1L □□□J	R85, R86, R90, R91, R103
	ACN-131	R71-R74 Wire wound resistor 0.22 (2W) x 2
	RD1/8PM □□□J	R1-R56, R81, R82, R88, R89, R95-R98
	RD¼PM □□□J	R57-R60, R75-R78, R92

OTHERS

Mark	Part No.	Symbol & Description
	AKB-094	Terminal 4P (TAPE1, TAPE2/ ADAPTOR)
	AKB-095	Terminal 6P (INPUT)
	AKE-104	Terminal (SPEAKERS)
	AKH-017	Transistor socket
★★	ASR-105	RL1 Relay
	VBZ30P080FBC	Screw 3x8

Control Assembly B

SEMICONDUCTORS

Mark	Part No.	Symbol & Description
★★	μPD4001BC (TC4001BP)	Q17
★★	2SC2603	Q18
★★	2SA1115	Q19
★	US1035 (1S1555)	D15-D28

SWITCH

Mark	Part No.	Symbol & Description
★★	ASH-031	S1, S2 Slide switch (TAPE DECK SELECTOR)

CAPACITORS

Mark	Part No.	Symbol & Description
	CKDYX 104M 25	C82
	ACG-024	C80, C81, C83 Ceramic capacitor (0.1/25V)
	CEA 100M 16L	C69
	CEA 3R3M 50L	C70-C72

RESISTORS

Note: When ordering resistors, convert the resistance value into code form, and then rewrite the part no. as before.

Mark	Part No.	Symbol & Description
	RD1/8PM □□□J	R105-R117

OTHERS

Mark	Part No.	Symbol & Description
	AKN-202	Mini jack (AUTO FUNCTION)

Socket Assembly A

SEMICONDUCTOR

Mark	Part No.	Symbol & Description
★	US1035	D35

CAPACITOR, SOCKET

Mark	Part No.	Symbol & Description
	CKDYB 222K 50	C52 Capacitor
	AKH-009	Transistor socket

Socket Assembly B

CAPACITOR, SOCKET

Mark	Part No.	Symbol & Description
	CKDYB 222K 50	C53 Capacitor
	AKH-009	Transistor socket

Socket Assembly C

CAPACITOR, SOCKET

Mark	Part No.	Symbol & Description
	CKDYB 222K 50	C54 Capacitor
	AKH-009	Transistor socket