

Service Manual

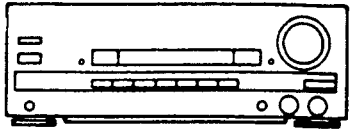

ORDER NO.
ARP1915

STEREO AMPLIFIER

A-Z560

MODEL A-Z560 HAS FOLLOWING VERSIONS:

Type	Power requirement	Export destination
HB	AC220V, 240V (switchable) *	United Kingdom
HE	AC220V, 240V (switchable) *	European continent
HEWZ	AC220V, 240V (switchable) *	West Germany

*Change the priary wiring.

- This manual is applicable to the A-Z560/HB and HE types.
- As to the HE type, refer to page 57.
- As to the other types, refer to applicable service manuals.
- SP-Z560 must be connected to A-Z560.(SP-Z560 cannot be connected to A-Z460 or A-Z360. Connecting SP-Z560 to A-Z460 or A-Z360 may cause a malfunction).
A-Z560 cannot be connected to GR-Z460. Connecting GR-Z460 to A-Z560 may cause a malfunction.
- As to the system composition, refer to the S-999D servicemanual(ARP1929).
- Ce manuel pour le service comprend les explications de réglage en français.
- Este manual de servicio trata del método ajuste escrito en español.

CONTENTS

1. SPECIFICATIONS	2	6. ADJUSTMENTS	47
2. EXPLODED VIEWS, PACKING AND PARTS LIST	3	6. RÉGLAGE	47
3. P.C.B's PARTS LIST	7	6. AJUSTE	47
4. SCHEMATIC DIAGRAMS AND P.C.BOARD CONNECTION DIAGRAMS	13	7. IC INFORMATION	48
5. BLOCK DIAGRAM	45	8. FOR HE TYPE	57
		9. PANEL FACILITIES	58

1. SPECIFICATIONS

Amplifier Section

Continuous Power Output (DIN) 80 W + 80 W
(1 kHz, T.H.D 1%, 8Ω)

Music power (DIN) 120 W + 120 W (1 kHz, T.H.D 1%, 8Ω)

D/A converter section

Signal-to-Noise Ratio More than 96 dB (EIAJ)

Dinamic range More than 94 dB (EIAJ)

Frequency range 25 Hz to 20 kHz

Total Harmonic Distortion (1 kHz, 40 W, 8Ω)...No more than 0.06%**

Input sensity

PHONO (MM) 2.5 mV

MIC 0.25 mV

VCR, DAT 150 mV

LD 250 mV

Output level

DAT, VCR 150 mV

MUTING - ∞

Power Supply/Miscellaneous

Power requirements a.c.240 Volts ~ , 50/60 Hz

Power consumption 410 W

AC outlets switched (x 1) 50 W

Dimensions 360 (W) x 315 (D) x 135.5 (H) mm

Weight (without package) 8.8 kg

Accessories

Operating instructions 1

Remote control unit 1

Dry cell batteries "AA" (IEC R6/UM-3) 1

** Measured By Audio Spectrum Analyzer.

Accessories

EP Adaptor 1

• Specifications and design subject to possible modification without notice due to improvement.

2. EXPLODED VIEWS, PACKING AND PARTS LIST

NOTES:

- Parts without part number cannot be supplied.
- The \triangle mark found on some component parts indicates the importance of the safety factor of the part. Therefore, when replacing, be sure to use parts of identical designation.
- Parts marked by "⊙" are not always kept in stock. Their delivery time may be longer than usual or they may be unavailable.

PARTS LIST OF EXTERIOR AND PACKING

Mark	No.	Description	Parts No.	Mark	No.	Description	Parts No.
					46	MOUNTING PLATE	
					47	FRONT PANEL ASSEMBLY	AMB1640
					48	P.C.B MOLD	
					49	LEG ASSEMBLY(S)	
					50	PLATE	AMR2138
					51	CHASSIS	
					52	REAR PANEL	
					53	BOTTOM PLATE	
					54	BONNET CASE	ANE1208
					55	PLATE	
					56	PLATE	
					57	PLATE	
					58	PLATE	
					59	HEAT SINK	
					60	SUB HEAT SINK	
					61	PLATE (GND)	
					62	SHIELD CASE	
					63	SHIELD COVER	
					64	OPERATING INSTRUCTIONS(E)	ARB1221
					65	BATTERY COVER	AZN1991
					66	DSP ASSEMBLY	AWK1231
					67	AF ASSEMBLY	AWZ2737
					68	DISPLAY ASSEMBLY	AWZ2743
					69	DAC ASSEMBLY	AWK1274
					70	REMORT CONTROL UNIT(CU-AX014)	AXD1130
					71	SCREW	BBZ26P060FMC
					72	SCREW	BBZ26P080FMC
					73	NUT	NK90FUC
					74	LEG ASSEMBLY	RXA1276
				\triangle	75	FU1 FUSE (T2.5A)	AEK-512
				\triangle	76	FU2 FUSE (T2A)	AEK-511
				\triangle	77	FU3 FUSE (T1.6A)	AEK-510
				\triangle	78	FU4 FUSE (T1.6A)	AEK-510
				\triangle	79	T1 POWER TRANSFORMER	ATS1227
					80	LCD DISPLAY ASSEMBLY	AAV1112
					81	POWER ASSEMBLY	AWZ2611
					82	STANDBY ASSEMBLY	AWZ2735
					83	SP TERMINAL ASSEMBLY	
					84	FUSE ASSEMBLY	
					85	MIC ASSEMBLY	
					86	POWER VR ASSEMBLY	
					87	HEAD PHONE ASSEMBLY	
					88	SUB TRANS ASSEMBLY	
	1	KNOB (VOLUME)	AAB1135				
	2	KNOB	AAB1136				
	3	BUTTON S	AAD1671				
	4	BUTTON L	AAD1672				
	5	BUTTON L	AAD1673				
	6	BUTTON (POWER)	AAD1674				
	7	BUTTON (FUNCTION)	AAD1675				
	8	BUTTON	AAD1682				
	9	ACRYLIC LENS L	AAK1757				
	10	ACRYLIC LENS S	AAK1758				
	11	ACRYLIC LENS	AAK1759				
	12	ACRYLIC PANEL	AAK1905				
	13	NAME PLATE					
	14	FRONT PANEL	AMB1641				
	15	SENSOR ACRYLIC	AAK1760				
	16	SASH R	AMR2083				
	17	SASH L	AMR2091				
	18	SCREW(STEEL)	ABA-283				
	19	SCREW	ABA-298				
	20	SCREW (STEEL)	ABA1009				
	21	SCREW(STEEL)	ABA1011				
	22	SCREW	ABA1018				
	23	SCREW(STEEL)	ABA1047				
	24	SCREW(STEEL)	ABA1050				
	25	SCREW(STEEL)	ABA1072				
	26	SCREW	ABA1098				
	27	SPRING	ABH1032				
\triangle	28	AC POWER CORD	ADG-051				
	29	SHEET					
	30					
	31	NYLON RIVET	AEC-471				
	32	NYLON RIVET	AEC-510				
\triangle	33	STRAIN RELIEF	AEC-882				
	34	PCB SUPPORT					
	35	CUSHION					
	36	P.C.B SPACER					
	37					
	38	PLATE					
	39	(UM3) BATTERIES(1.5V)					
	40	FRONT PAD	AHA1272				
	41	REAR PAD	AHA1273				
	42	PACKING CASE	AHD1776				
	43					
	44	SHEET	AHG1016				
	45	TERMINAL SCREW					

PACKING

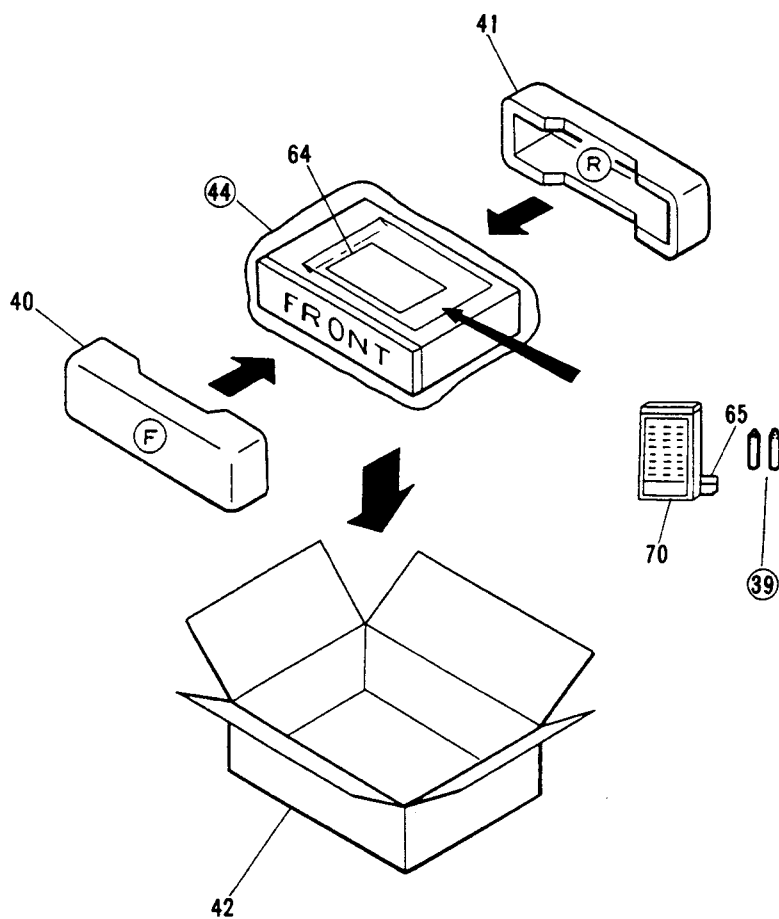

A

B

C

D

3. P.C.B's PARTS LIST

NOTES:

- Parts without part number cannot be supplied.
- Parts marked by "⊙" are not always kept in stock. Their delivery time may be longer than usual or they may be unavailable.
- The Δ mark found on some component parts indicates the importance of the safety factor of the part. Therefore, when replacing, be sure to use parts of identical designation.
- When ordering resistors, first convert resistance values into code form as shown in the following examples.

Ex. 1 When there are 2 effective digits (any digit apart from 0), such as 560 ohm and 47k ohm (tolerance is shown by J = 5%, and K = 10%).

560Ω	56 × 10 ¹	561.....	RD1/4PS	⊙	⊙	⊙	J
47kΩ	47 × 10 ³	473.....	RD1/4PS	⊙	⊙	⊙	J
0.5Ω	0R5.....		RN2H	⊙	⊙	⊙	K
1Ω	010.....		RS1P	⊙	⊙	⊙	K

Ex. 2 When there are 3 effective digits (such as in high precision metal film resistors).

5.62kΩ	562 × 10 ¹	5621.....	RN1/4SR	⊙	⊙	⊙	F
--------	-----------------------	-----------	---------	---	---	---	---

Mark	No.	Description	Parts No.	Mark	No.	Description	Parts No.
DSP ASSEMBLY(AWK1231)				C926		ELECTR.CAPACITOR	CEAS470M25
SEMICONDUCTORS				C927		CERAMIC CAPACITOR	ACG1022
	IC901-903		M5218P	C928-930		ELECTR.CAPACITOR	CEAS470M25
	IC904		TD6726N	C931		ELECTR.CAPACITOR	CEAS010M50
	IC905		PD0051	C932		CERAMIC CAPACITOR	ACG1022
	IC906,907		MB81464-12	C933		ELECTR.CAPACITOR	CEAS101M16
	IC908		PDG044-A	C934		ELECTR.CAPACITOR	CEAS101M50
	Q901	TRANSISTOR	DTA143ES	C935		CERAMIC CAPACITOR	CKDYF473Z50
	D901,902	DIODE	HSS104-02	C936		CERAMIC CAPACITOR	ACG1021
				C937,938		CERAMIC CAPACITOR	CCDCH100D50
COILS				C939,940		CERAMIC CAPACITOR	ACG1022
	L901-903	AXIAL INDUCTOR	LAU330K	C941		CERAMIC CAPACITOR	CKDYF473Z50
	L904		LAUR22M	C943,944		ELECTR.CAPACITOR	CEAS101M50
	L905,906	AXIAL INDUCTOR	LAU220K	C945		CERAMIC CAPACITOR	CKDYF473Z50
	L999	AXIAL INDUCTOR	LAU330K	C947,948		CERAMIC CAPACITOR	ACG1021
	F901,902	FILTER	ATF1071	RESISTORS			
CAPACITORS				R952,953		CARBON FILM RESISTOR	RD1/4PM390J
	C901,902	ELECTR. CAPACITOR	CEAS2R2M50	R955		RESISTOR ARRAY(10K)	RA7T103J
	C903,904	MYLOR FILM CAPACITOR	CQMA563J50	VR901,902		Other resistors	VRTB6VS102
	C905,906	ELECTR. CAPACITOR	CEAS220M25				RD1/8PM□□□J
	C907,908	PL.STYRENE CAPACITOR	CQSA182J50	OTHERS			
	C909,910	CERAMIC CAPACITOR	CCCSL151J50	CN6		JUMPER CONNECTOR	KPE15
	C911,912	CERAMIC CAPACITOR	CCCSL180L50			15-P	
	C913-916	CERAMIC CAPACITOR	CKCYX473M25	CN7		JUMPER CONNECTOR	KPE12
	C917,918	ELECTROLYTIC CAPACITOR	CEANP470M16			12-P	
	C919	CERAMIC CAPACITOR	CCDCH100D50	X901			ASS1036
	C920	CERAMIC CAPACITOR	CCDCH330J50	X902			ASS1035
	C921	CERAMIC CAPACITOR	CKDYF473Z50	X903			ASS1015
	C922	CERAMIC CAPACITOR	CCDCH100D50				
	C923	CERAMIC CAPACITOR	CKDYF473Z50				
	C924	ELECTR. CAPACITOR	CEAS470M10				
	C925	CERAMIC CAPACITOR	ACG1022				

Mark	No.	Description	Parts No.
POWER ASSEMBLY (AWZ2611)			
SEMICONDUCTOR			
	IC401	AUDIO IC	STK4211-5P
CAPASITORS			
	C401,402	MYLOR FILM CAPACITOR	CQMA512J50
	C403	ELECTR.CAPACITOR	CEAS4R7M50
	C404	ELECTROLYTIC CAPACITOR	CEHAQ4R7M50
	C405,406	CERAMIC CAPACITOR	CCDSL470J50
	C407,408	ELECTROLYTIC CAPACITOR	CEYA101M50
	C409,410	CERAMIC CAPACITOR	CKDYB102K50
	C411,412	ELECTR.CAPACITOR	CEAS010M50
	C413,414	ELECTR.CAPACITOR	CEAS220M50
	C415,416	ELECTR.CAPACITOR	CEAS470M50
	C417,418	ELECTR.CAPACITOR	CEAS101M25
	C423	ELECTR.CAPACITOR	CEAS470M50
	C425,426	CERAMIC CAPACITOR	CCDSL030C50
	C427-430	ELECTROLYTIC CAPACITOR	CEYA220M50

RESISTORS

	R405,406	CARBON FILM RESISTOR	RD1/4PM563J
	R411-414	CARBON FILM RESISTOR	RD1/2PM472J
△	R417,418	CARBON FILM RESISTOR	RD1/4PMFL222J
	R419	CARBON FILM RESISTOR	RD1/2PM102J
△	R420-422	CARBON FILM RESISTOR	RD1/4PMFL□□□J
		Other resistor	RD1/8PM□□□J

STANDBY ASSEMBLY (AWZ2735)

SEMICONDUCTORS

	IC151		NJM78M56FA
	Q152	TRANSISTOR	2SB560
	Q554	TRANSISTOR	2SD438
	D151-154	DIODE	S5566
	D156	ZENER DIODE	RD33ESB2
	D157	ZENER DIODE	RD6.2ESB
CAPACITORS			
	C151	ELECTROLYTIC CAPACITOR	CEHAQ222M16
	C152	ELECTROLYTIC CAPACITOR	CEHAQ471M16
	C153	ELECTROLYTIC CAPACITOR	CEHAQ221M50

Mark	No.	Description	Parts No.
	C156	ELECTROLYTIC CAPACITOR	CEHAQ221M50
	C157	ELECTROLYTIC CAPACITOR	CEHAQ220M50
	C158	ELECTROLYTIC CAPACITOR	CEHAQ470M50
	C159	ELECTROLYTIC CAPACITOR	CEHAQ221M10
RESISTORS			
△	R151	METAL OXIDE RESISTOR	RS3LMF561J
△	R153	METAL OXIDE RESISTOR	RS2LMF222J
△	R154,155	CARBON FILM RESISTOR	RD1/4PMF470J
△	R157	CARBON FILM RESISTOR	RD1/4PMFL4R7J
		Other resistor	RD1/8PM□□□J

AF ASSEMBLY (AWZ2737)

SEMICONDUCTORS

	IC101	REGURATOR IC	UPC78M05F
	IC102	REGURATOR IC	NJM78M05F
	IC103	REGULATOR IC	NJM79M051A
	IC104	REGURATOR IC	UPC78M12F
	IC105		TA7291S
	IC201	OP-AMP IC	M5218P
	IC202	LOGIC IC	TC4066BP
	IC203	LOGIC IC	TC4052BP
	IC204	OP-AMP IC	M5218L
	IC205	E-SW IC	LC4966
	IC206	LOGIC IC	TC4052BP
	IC207	OP-AMP IC	M5218P
	IC208	OP-AMP IC	M5218L
	IC501	LOGIC IC	TC4052BP
	Q101	TRANSISTOR	2SB560
	Q102	TRANSISTOR	2SA970
	Q103-105	TRANSISTOR	2SC2458
	Q106	TRANSISTOR	2SD438
	Q107,108	TRANSISTOR	DTC124ES
	Q501	TRANSISTOR	2SA1048
	Q502	TRANSISTOR	2SC2458
	Q503	TRANSISTOR	2SA1048
	Q551	TRANSISTOR	2SA1048
	Q552	TRANSISTOR	2SC2603
	Q553	TRANSISTOR	2SA1048
	D101	DIODE	RBV602
	D102-107	DIODE	S5566
	D108	DIODE	RB152
	D109	DIODE	HSS104-02

Mark	No.	Description	Parts No.
SP TERMINAL ASSEMBLY			
SEMICONDUCTORS			
	D451,452	ZENER DIODE	RD12ESB3
RELAY			
	RY451	RELAY	ASR-112
COILS			
	L451,452	COIL	ATH1004
CAPACITORS			
	C461-464	MYLOR FILM CAPACITOR	CQMA104J50
	C465	ELECTROLYTIC CAPACITOR	CEANP4R7M100
RESISTORS			
	R461-464	CARBON FILM RESISTOR	RD1/4PMFL100J
OTHERS			
	CN3	JUMPER CONNECTOR 5-P	KPC5
		PHONO JACK 2-P	AKB1039
		SPEAKER TERMINAL 4-P	AKE-109
FUSE ASSEMBLY			
No Parts are supplied with the fuse assembly.			
MIC ASSEMBLY			
SEMICONDUCTORS			
	IC601		M5218P
	Q601,602	TRANSISTOR	2SC2458
	D601,602	DIODE	HSS104-02
CAPACITORS			
	C601	ELECTROLYTIC CAPACITOR	CEJA220M16
	C602	CERAMIC CAPACITOR	ACG1019
	C603	ELECTROLYTIC CAPACITOR	CEJA3R3M50
	C604	CERAMIC CAPACITOR	ACG1017
	C605	AUDIO FILM CAPACITOR	CFTXA474J50
	C606	CERAMIC CAPACITOR	CKCYB681K50
	C607	ELECTROLYTIC CAPACITOR	CEJA100M25
	C608	ELECTR CAPACITOR	CEJA010M50
	C609	ELECTR CAPACITOR	CEAS470M10
	C610	ELECTR CAPACITOR	CEJA470M10

Mark	No.	Description	Parts No.
	C611	CERAMIC CAPACITOR	CKCYF103Z50
	C612,613	ELECTROLYTIC CAPACITOR	CEJA100M25
RESISTORS			
	VR601	VARIABLE (100K-X1)	ACS1026
	VR602	VARIABLE (10K-X1)	ACS1025
	R614,615	CARBON FILM RESISTOR	RD1/4PM390J
		others resistor	RD1/8PM□□□J
OTHERS			
		JACK	AKN1017
POWER VR ASSEMBLY			
SEMICONDUCTOR			
	IC651		M5220P
CAPACITORS			
	C651,652	ELECTR.CAPACITOR	CEAS100M25
	C653,654	ELECTR.CAPACITOR	CEAS470M10
	C655	CERAMIC CAPACITOR	CKCYX103M25
	C656	ELECTR.CAPACITOR	CEAS470M10
	C657,658	CERAMIC CAPACITOR	CCCSL390J50
RESISTORS			
	VR651		ACX1027
	R659-661	CARBON FILM RESISTOR	RD1/4PM390J
		Other resistors	RD1/8PM□□□J
OTHERS			
	CN2	JUMPER CONNECTOR 15-P	KPE15
HEAD PHONE ASSEMBLY			
CAPACITOR			
	C451	CERAMIC CAPACITOR	CKDYX104M25
RESISTORS			
	△ R453-456	METAL OXIDE RESISTOR	RS2LMF331J
OTHER			
		JACK	AKN1010

Mark	No.	Description	Parts No.	Mark	No.	Description	Parts No.
	D110	ZENER DIODE	RD33ESB2		C245	ELECTR.CAPACITOR	CEASR22M50
	D111	ZENER DIODE	RD6.2ESB		C247,248	ELECTROLYTIC CAPACITOR	CEYA470M50
	D112,113	DIODE	HSS104-02		C502,503	ELECTR.CAPACITOR	CEAS101M10
	D114	ZENER DIODE	RD3.0ESB1		C504	ELECTROLYTIC CAPACITOR	CEAS102M6
	D115	DIODE	HSS104-02		C505	CERAMIC CAPACITOR	CCCSL270J50
	D116	ZENER DIODE	RD4.7ESB		C506	ELECTROLYTIC CAPACITOR	CEAS102M6
	D117	DIODE	HSS104-02		C507509	ELECTR.CAPACITOR	CEAS101M10
	D158	ZENER DIODE	RD12ESB3				
	D501	DIODE	HSS104-02				
COILS				RESISTORS			
	L501,502	AXIAL INDUCTOR	LAU101K	△	R101,102	METAL OXIDE RESISTOR	RS2LMFR22J
CAPACITORS				△	R103	METAL OXIDE RESISTOR	RS2LMF222J
	C101	CKA (0.01μF/AC250V)	ACG1005	△	R105,106	CARBON FILM RESISTOR	RD1/4PMF470J
	C102,103	CERAMIC CAPACITOR	CKDYF103Z50	△	R120	METAL OXIDE RESISTOR	RS2LMF8R2J
	C104,105	ELECTROLYTIC CAPACITOR	ACH1031		R121,122	METAL OXIDE RESISTOR	RS1LMF8R2J
	C106,107	ELECTR. CAPACITOR	CEAS222M16	△	R129	CARBON FILM RESISTOR	RD1/2PMFL2R2
	C108	ELECTR. CAPACITOR	CEAS471M50		R130,131	CARBON FILM RESISTOR	RD1/2PM472J
	C109	ELECTR.CAPACITOR	CEAS332M25	△	R132-135	CARBON FILM RESISTOR	RD1/4PM100J
	C110	ELECTR.CAPACITOR	CEHAQ101M50	△	R136	METAL OXIDE RESISTOR	RS2LMF2R2J
	C111,112	ELECTR.CAPACITOR	CEAS101M50		R217,218	CARBON FILM RESISTOR	RD1/4PM390J
	C113	ELECTROLYTIC CAPACITOR	CEHAQ220M50	△	R289,290	CARBON FILM RESISTOR	RD1/8PM104J
	C114	ELECTROLYTIC CAPACITOR	CEHAQ470M50			Other resistors	RD1/8PM□□□□
	C115	ELECTR. CAPACITOR	CEHAQ101M50	OTHERS			
	C116	ELECTROLYTIC CAPACITOR	CEHAQ221M10			PHONO JACK 4-P	AKB-115
	C117	ELECTR. CAPACITOR	CEAS100M25			PHONO JACK 1-P	AKB1105
	C118	CERAMIC CAPACITOR	CKCYX103M25			PHONO JACK 9-P	AKB1128
	C119	ELECTR. CAPACITOR	CEAS221M10			PLUG 10-P	AKM1037
	C120	ELECTR.CAPACITOR	CEAS010M50			JACK (DC)	AKN-203
	C121	CERAMIC CAPACITOR	ACG1021			SOCKET 4-P	AKP1046
	C160	ELECTR.CAPACITOR	CEAS101M50			SOCKET 14-P	AKP1048
	C201,202	CERAMIC CAPACITOR	ACG1017			SOCKET 15-P	AKP1049
	C203,204	ELECTR. CAPACITOR	CEAS2R2M50			SOCKET 13-P	AKP1052
	C205,206	ELECTR. CAPACITOR	CEAS100M25				
	C207,208	CERAMIC CAPACITOR	ACG1017				
	C209,210	CERAMIC CAPACITOR	CKCYB152K50				
	C211,212	CERAMIC CAPACITOR	CKCYB562K50				
	C213,214	ELECTR.CAPACITOR	CEAS010M50				
	C215,216	ELECTR.CAPACITOR	CEAS470M10				
	C217,218	ELECTR.CAPACITOR	CEAS4R7M50				
	C219,220	ELECTR.CAPACITOR	CEAS100M25				
	C221,222	ELECTROLYTIC CAPACITOR	CEYA470M50				
	C223,224	ELECTR.CAPACITOR	CEAS100M25				
	C233-236	ELECTR.CAPACITOR	CEAS100M25				
	C237	CERAMIC CAPACITOR	CKDYX104M25				
	C238	CERAMIC CAPACITOR	CKDYF473Z50				
	C239,240	ELECTR.CAPACITOR	CEAS2R2M50				
	C241-244	ELECTR.CAPACITOR	CEAS100M25				

Mark No.	Description	Parts No.
DISPLAY ASSEMBLY (AWZ2743)		
SEMICONDUCTOR		
IC701		PD5118
Q701-704	TRANSISTOR	DTA124ES
Q705	TRANSISTOR	DTA143ES
Q707,708	TRANSISTOR	DTA124ES
Q709-711	TRANSISTOR	DTC124ES
Q712,713	TRANSISTOR	2SC2458
Q716	TRANSISTOR	DTC124ES
Q717,718	TRANSISTOR	2SC2458
D701,702	DIODE	HSS104-02
D703		AEL1100
D704-706	DIODE	HSS104-02
D707,708	LED(RED)	AEL1099
D710	LED(RED)	AEL1099
D712	LED(RED)	AEL1099
D714,715	LED(RED)	AEL1099
D717,718	LED(RED,AMBER)	AEL1101
D719-721	DIODE	HSS104-02
D722	LED(RED)	AEL1099
D723,724	DIODE	HSS104-02
D730	DIODE	HSS104-02
SWITCHES		
S701-714	SWITCH	ACG1029
COILS		
L701	AXIAL INDUCTOR	LAU101K
CAPACITORS		
C701	CERAMIC CAPACITOR	CKCYX473M25
C702	ELECTR.CAPACITOR	CEAS221M10
C703,704	CERAMIC CAPACITOR	CKCYX103M25
C705	CERAMIC CAPACITOR	CKCYB102K50
C706	ELECTR.CAPACITOR	CEAS010M50
C707	CEA(47000/5.5V)	ACH1070
C708	ELECTR.CAPACITOR	CEAS4R7M50
C709,710	CERAMIC CAPACITOR	ACG1021
C711	CERAMIC CAPACITOR	CKCYX473M25
RESISTORS		
R742	RESISTOR ARRAY (100K)	RA5T104J
R744	RESISTOR ARRAY (100K)	RA6T104J
R761	RESISTOR ARRAY (10K)	RA4T104J
	Other resistors	RD1/8PM□□□□
OTHERS		
X701	CERAMIC RESONATOR	ASS1025
	SOCKET 10-P	AKP1044
	REMOTE RECEIVER UNIT	AXX1010

Mark No.	Description	Parts No.
SUB TRANS ASSEMBLY		
SEMICONDUCTOR		
D191,912	ZENER DIODE	RD6.2ESB3
RELAY		
△ RY191	RELAY	ASR1024
TRANSFORMER		
△ T191	POWER TRANSFORMER	ATT1115
CAPACITORS		
△ C191,192	CKA(0.01/AC400V)	ACG1003
OTHERS		
△	AC SOCKET 1-P	AKP1035
	SOCKET 8-P	AKP1045
DAC ASSEMBLY (AWK1274)		
SEMICONDUCTOR		
IC801		TC74HCU04AP
IC802	DIGITAL I.F.	PD0037
IC803		PD0036
IC804		TC74HC32AP
IC805	D/A CONVERTER	LC78820-B
IC806		NJM072D-E
IC807		M5218P
Q801,802	TRANSISTOR	2SA1048
Q803	TRANSISTOR	2SC3377
Q804,805	TRANSISTOR	2SC2458
Q806,807	TRANSISTOR	2SC2878
Q808,809	TRANSISTOR	DTC124ES
D801-808	DIODE	HSS104-02
COILS		
L801,802	AXIAL INDUCTOR	LAU330K
L803,804		ATX1008
L805-808	AXIAL INDUCTOR	LAU010M
L809	FERRITE BEAD	ATX1008
L810-813	AXIAL INDUCTOR	LAU010M
L817	AXIAL INDUCTOR	LAU010M
L818	FERRITE BEAD	ATX1008
L819,820	AXIAL INDUCTOR	LAU010M
CAPACITORS		
C805	CERAMIC CAPACITOR	CKCYX473M25
C806	CERAMIC CAPACITOR	ACG1021
C807	ELECTR.CAPACITOR	CEAS010M50
C808	CERAMIC CAPACITOR	ACG1021
C809	ELECTR.CAPACITOR	CEAS101M10

Mark	No.	Description	Parts No.
	C810	ELECTR.CAPACITOR	CEAS010M50
	C811	AUDIO FILM CAPACITOR	CFTXA224J50
	C812	ELECTR.CAPACITOR	CEAS470M10
	C813	CERAMIC CAPACITOR	ACG1021
	C814	CERAMIC CAPACITOR	CCDCH220J50
	C815	ELECTR.CAPACITOR	CEAS101M10
	C816	CERAMIC CAPACITOR	ACG1022
	C818	ELECTROLYTIC CAPACITOR	CEYA101M16
	C819	MICA CAPACITOR	CMA220J500
	C820	ELECTR.CAPACITOR	CEAS470M10
	C821,822	CERAMIC CAPACITOR	CKCYX473M25
	C823	ELECTROLYTIC CAPACITOR	CEYA101M16
	C826	ELECTROLYTIC CAPACITOR	CEYA101M16
	C827	ELECTROLYTIC CAPACITOR	CEYA221M16
	C828,829	ELECTROLYTIC CAPACITOR	CEYA220M50
	C830,831	MYLOR FILM CAPACITOR	CQMA683J50
	C832,833		CQMXA472J100
	C834,835	PL.STYRENE CAPACITOR	CQSA471J50
	C836,837	MYLOR FILM CAPACITOR	CQMA471J50
	C838,839	ELECTR.CAPACITOR	CEAS220M16
	C840,841		CQMXA102J100
	C842,843	ELECTR.CAPACITOR	CEAS470M10
	C844,845	CERAMIC CAPACITOR	CKCYB222K50
	C847	ELECTR.CAPACITOR	CEASR47M50
RESISTORS			
	R849,850	CARBON FILM RESISTOR	RD1/4PM390J
		Other resistors	RD1/8PM□□□J
OTHERS			
	CN1	JUMPER CONNECTOR 11-P	KPE11
	CN5	JUMPER CONNECTOR 8-P	KPE8
		DIGITAL JACK 1-P	AKB1073
	IC		AKX1015

EXTERIOR

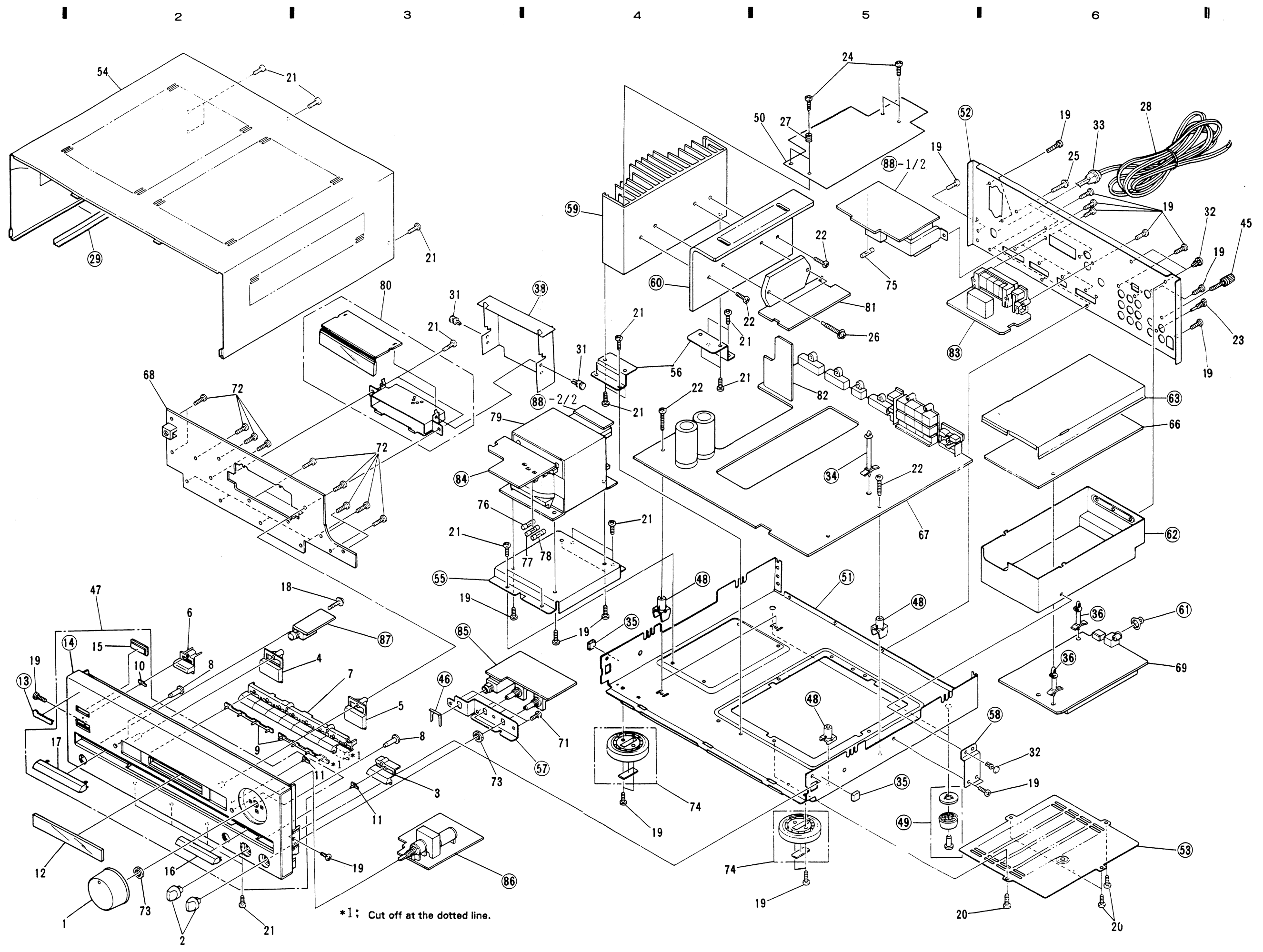

4. SCHEMATIC DIAGRAMS AND P.C. BOARD CONNECTION DIAGRAMS

4.1 OVER ALL SCHEMATIC DIAGRAM

A

B

C

D

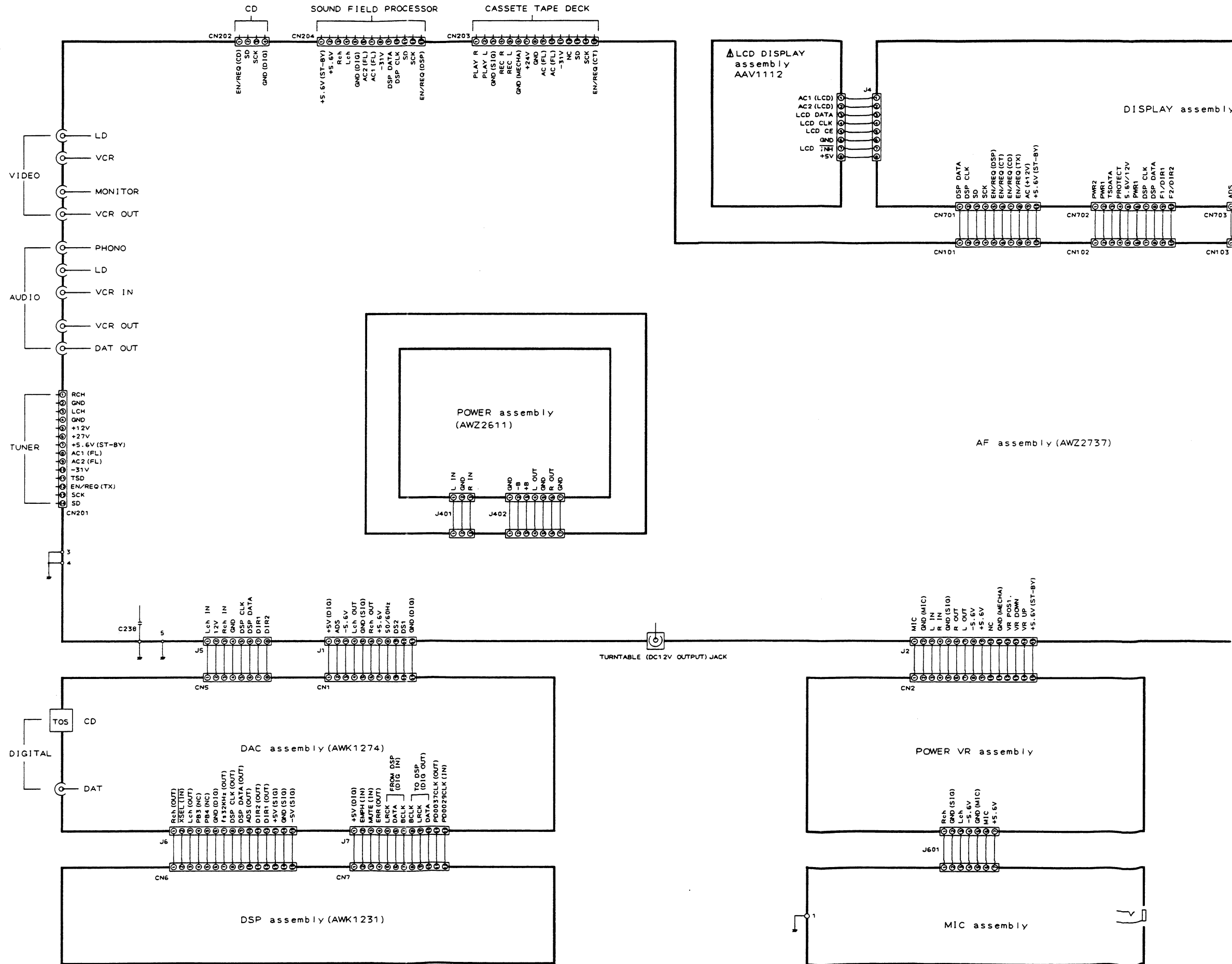

1

2

3



4



5

6

1. RESISTORS
 Indicated in Ω , 1/8W, 1/4W, $\pm 5\%$ tolerance unless otherwise noted k: k Ω , M: M Ω , (F): $\pm 1\%$, (G): $\pm 2\%$, (N): $\pm 20\%$ tolerance.

2. CAPACITORS
 Indicated in capacity (μ F)/voltage (V) unless otherwise noted p: pF.
 Indication without voltage is 50V except electrolytic capacitor.

3. VOLTAGE CURRENT
: Signal voltage at 80W + 80W, 8 Ω output (1kHz).
: DC voltage (V) at no input signal.
 Value in () is DC voltage at rated power.
: DC current at no input signal.

4. OTHERS
: Signal route
: Adjusting point.
 The Δ mark found on some components parts indicates the importance of the safety factor of the parts.
 Therefore, when replacing, be sure to use parts of identical designation.
 * marked capacitor and resistor have parts number.
 This is the basic schematic diagram, but the actual circuit may vary due to improvements in design.

5. SWITCHES

DISPLAY assembly			
S701	POWER	S708	CD
S702	LSS SET	S709	LD
S703	LSS MODE	S710	VCR
S704	PHONO	S712	DIRECT
S705	TUNER	S713	MUTE
S706	TAPE	S714	SURR.
S707	DAT		

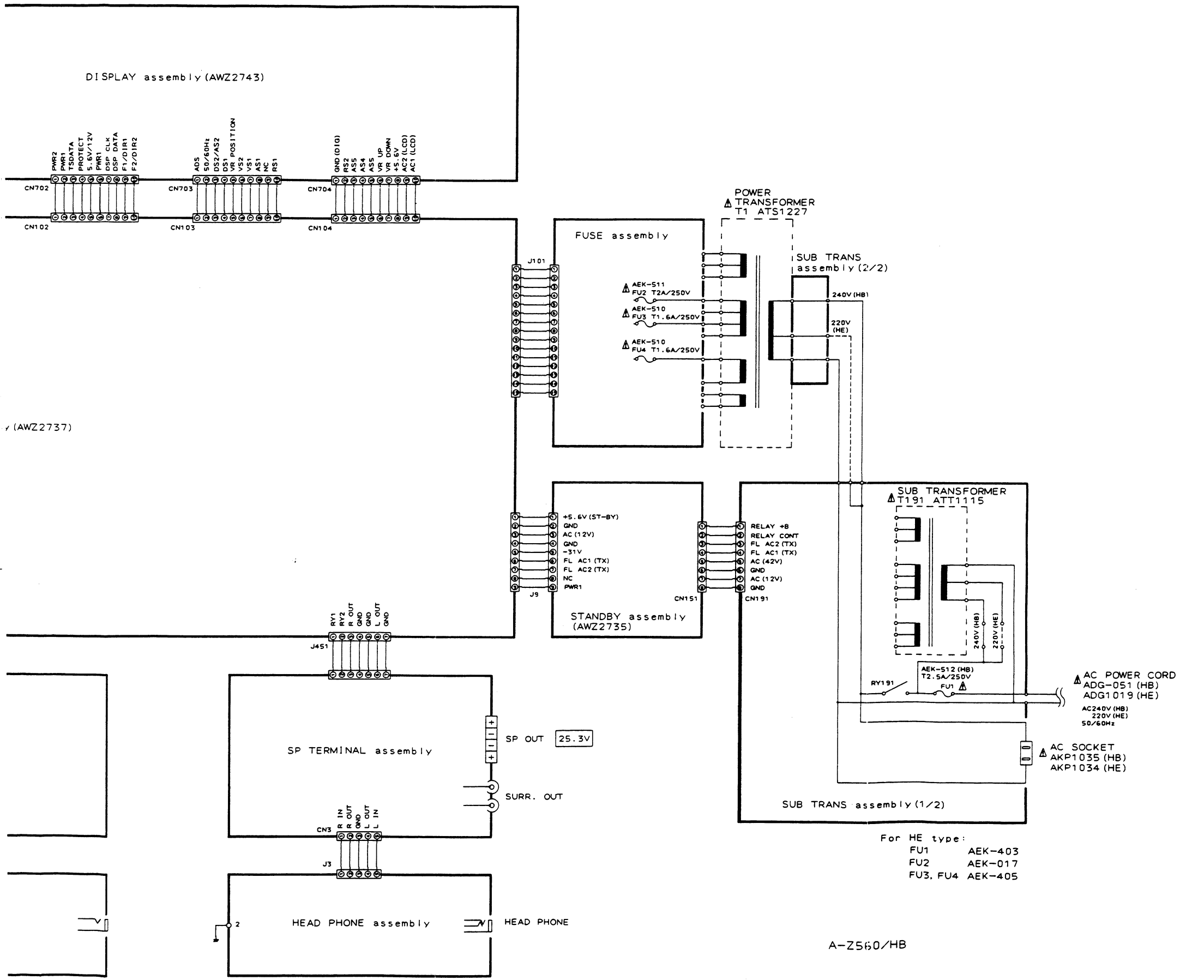

For HE type:
 FU1 AEK-403
 FU2 AEK-017
 FU3, FU4 AEK-405

A-Z560/HE

4.2 AF (AWZ2737), STANDBY (AWZ2735), SP TERMINAL, FUSE, POWER (AWZ2611), MIC, POWER VR, SUB TRANS and HEAD PHONE assembly

A

B

C

D

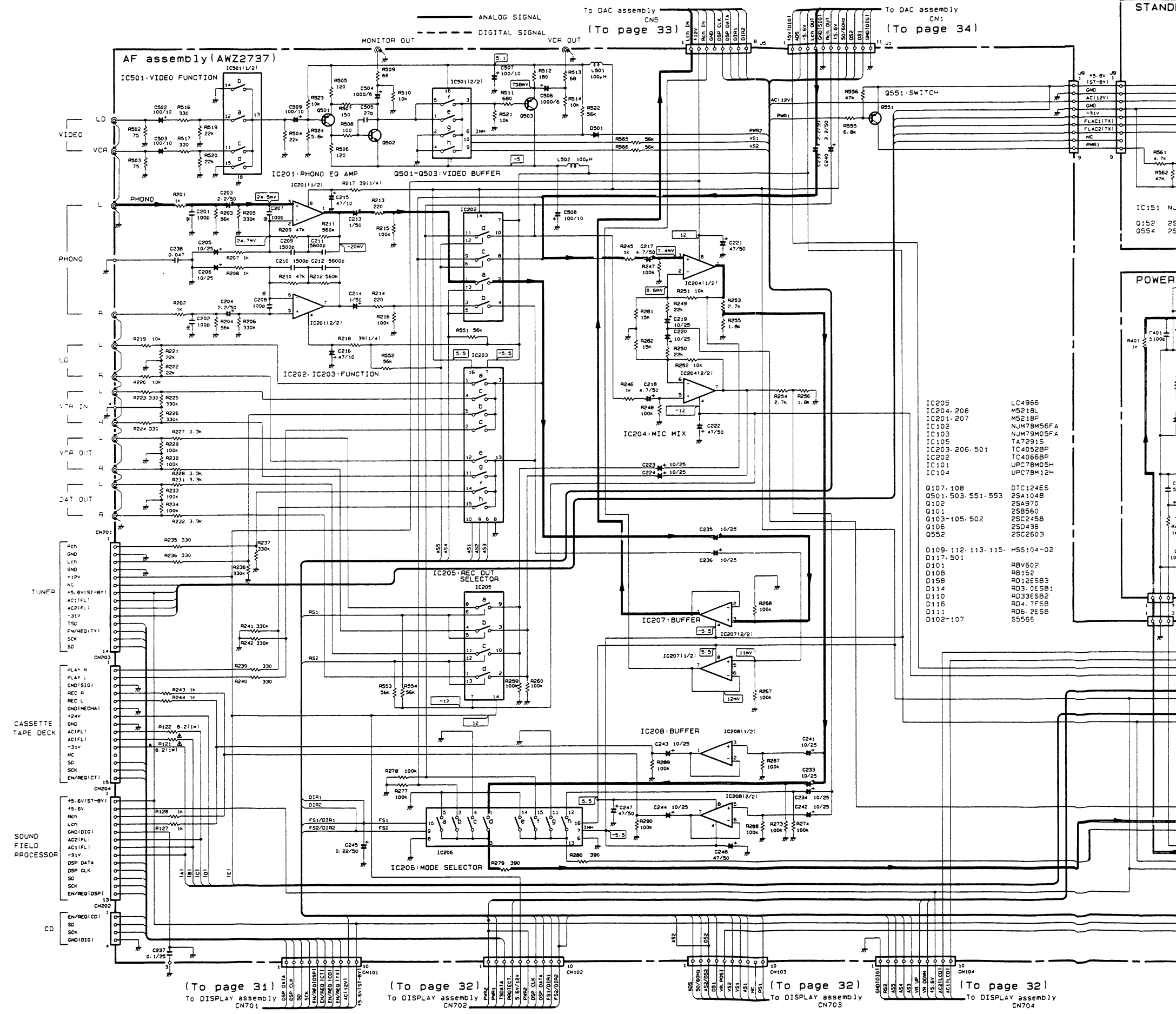

- IC205 LC4966
 - IC204, 208 MS218L
 - IC201, 207 MS218P
 - IC102 NJM78M56FA
 - IC103 NJM79M05FA
 - IC105 TA7291S
 - IC203, 206, 501 TC4052BP
 - IC202 TC4065BP
 - IC101 UPC78M05H
 - IC104 UPC78M12H
-
- 0107, 108 DTC124ES
 - 0501, 503, 551, 553 2SA104B
 - 0102 2SA970
 - 0101 2SB950
 - 0103-105, 502 2SC245B
 - 0105 2SD43B
 - 0552 2SC2603
-
- D109, 112, 113, 115, HSS104-02
 - D117, 501 RBV60P
 - D101 RB152
 - D108 RD12ESB3
 - D114 RD3, 0ESB1
 - D110 RD39ESB2
 - D116 RD4, 7FSSB
 - D111 RD6, 2ESB
 - D102-107 S5565

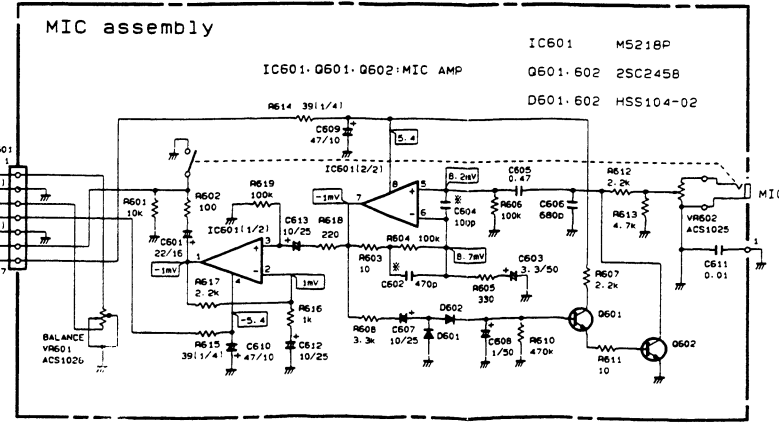
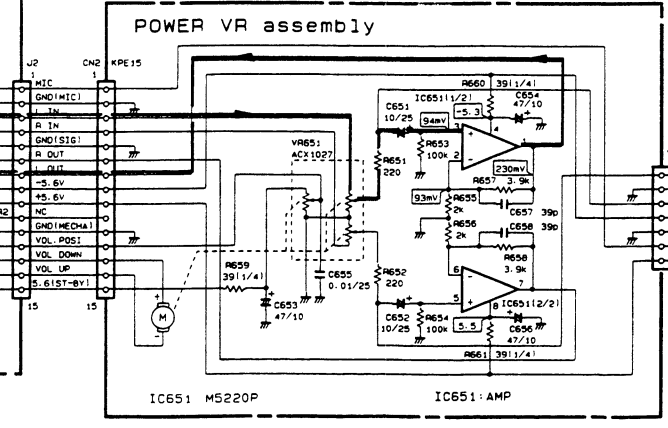
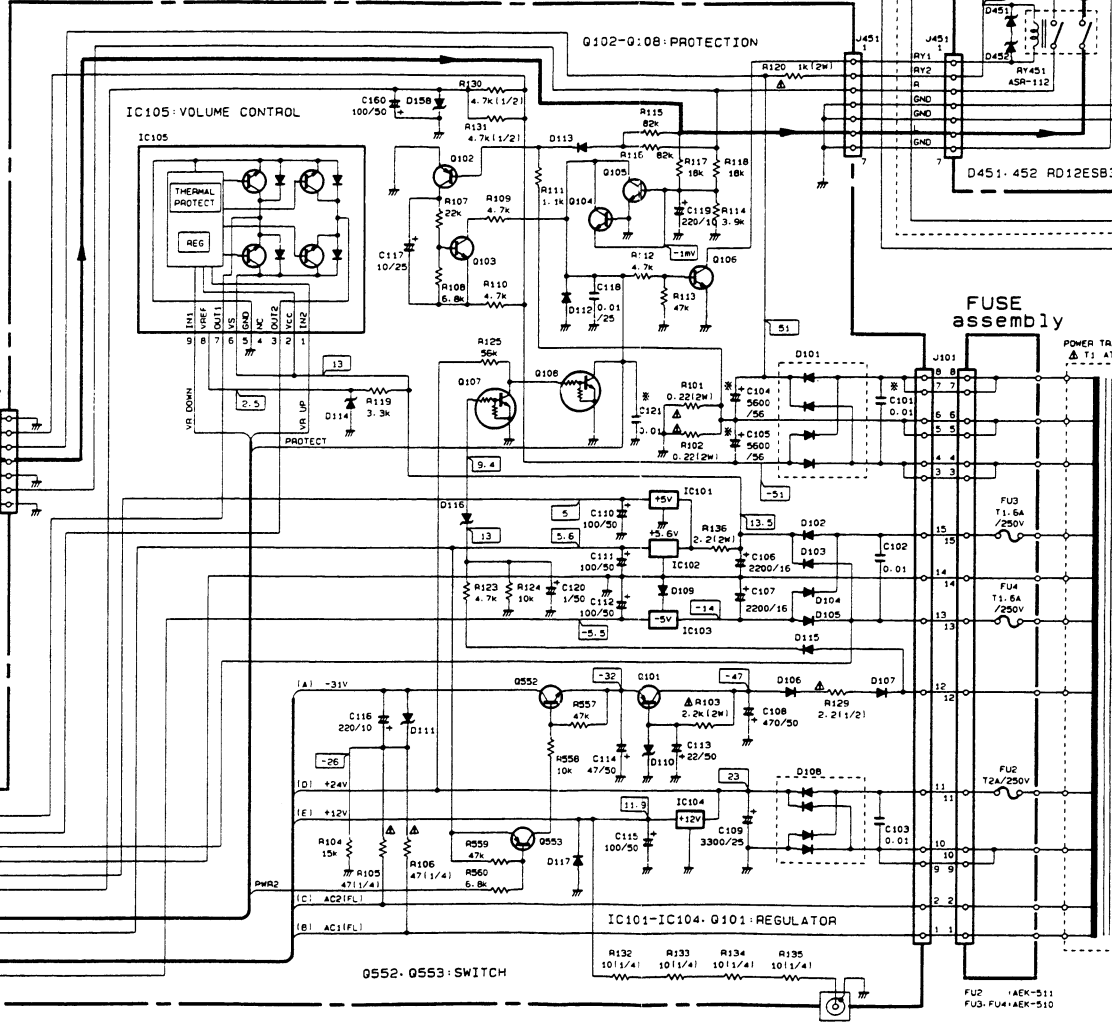
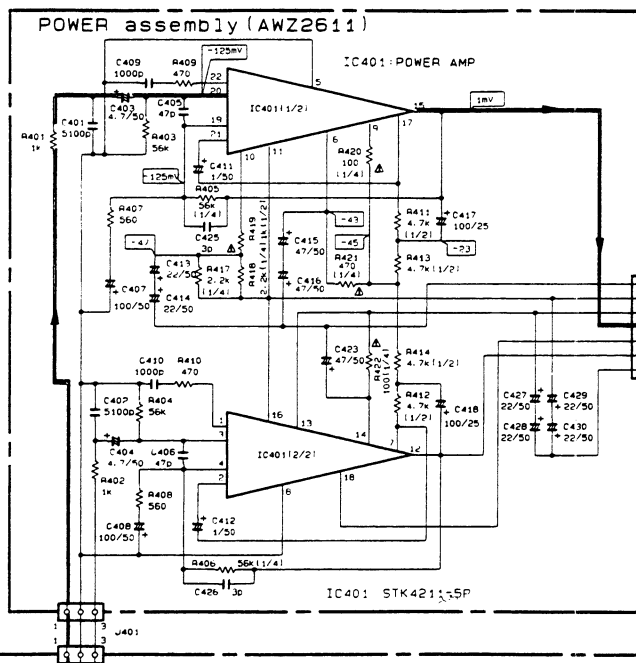
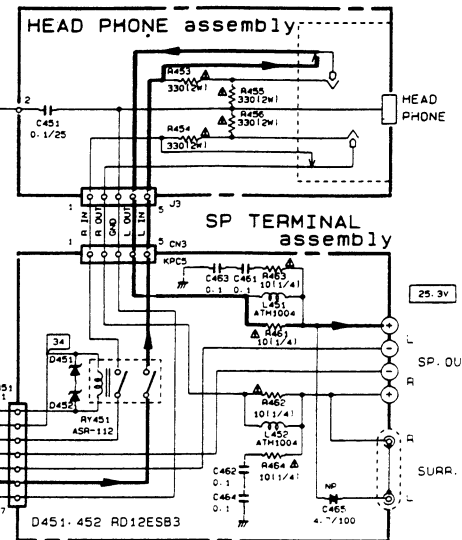
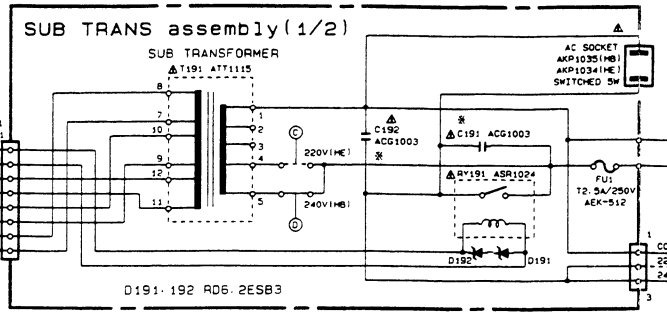
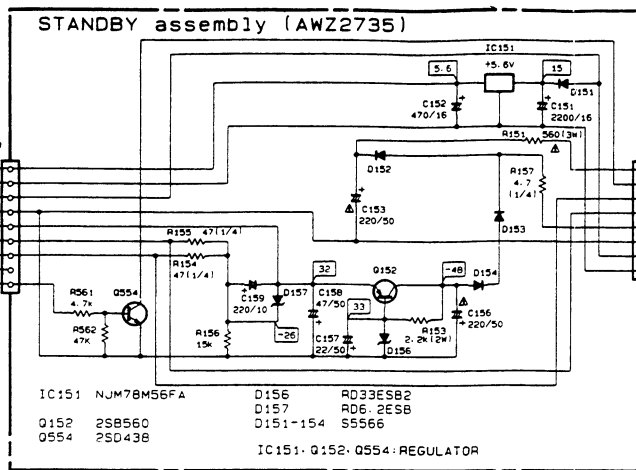

- LC4966
- MS218L
- MS218P
- NJM78M56FA
- NJM79M05FA
- TA7291S
- TC4052BP
- TC4066BP
- UPC78M05H
- UPC78M12H
- D1C124ES
- 2SA104B
- 2SA970
- 2SB560
- 2SC2458
- 2SD438
- 2SC2603
- HSS104-02
- RBV602
- RB152
- RD12ESB3
- RD3.0ESB1
- RD33ESB2
- RD4.7ESB
- RD6.2ESB
- S5566

1 2 3 4 5 6

AF assembly (AWZ2737)

To DAC assembly CN5
(To page 35)

To DAC assembly CN1
(To page 35)

POWER VR assembly

A
IC201
IC202
IC206
IC205
IC204
IC203
IC208
IC207

B
IC501
Q503
Q103
Q502
Q102
Q106
Q501
Q104
Q105

C
Q108
Q107
D
Q101
Q552
Q551
Q553

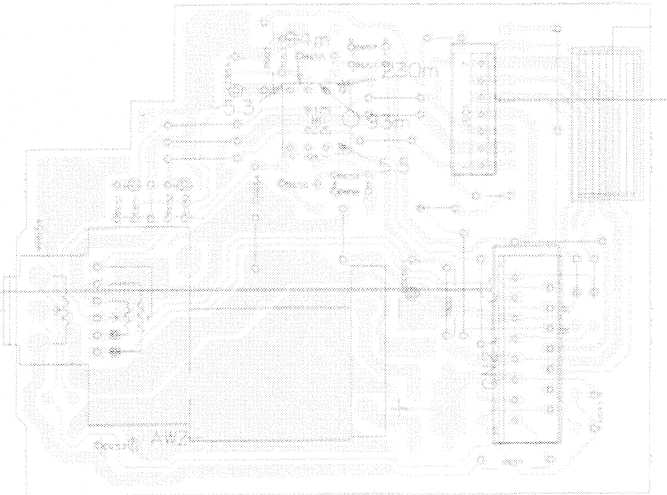
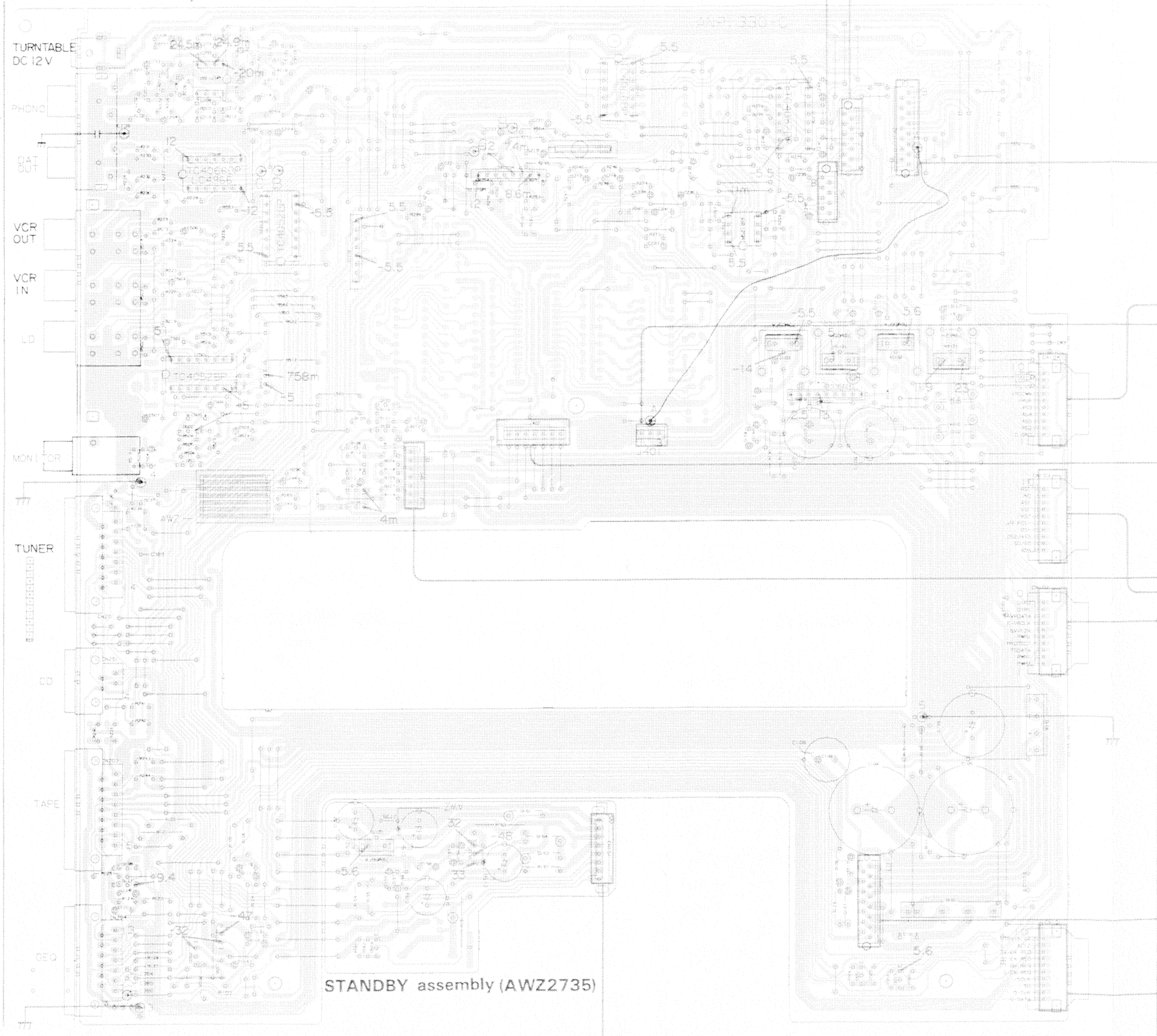

To DISPLAY assembly CN704
(To page 30)

POWER assembly (AWZ2611)

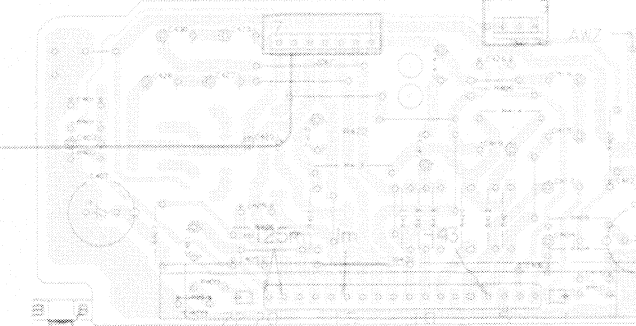

To DISPLAY assembly CN703 (To page 30)

To DISPLAY assembly CN702
(To page 29)

FUSE assembly

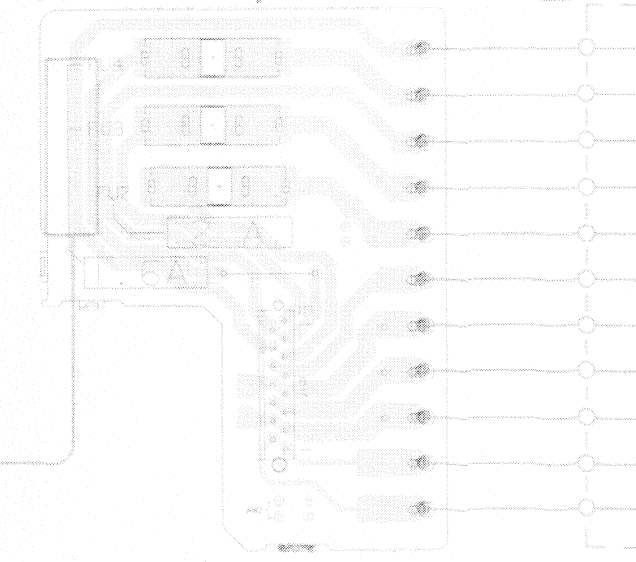

To DISPLAY assembly CN701
(To page 29)

STANDBY assembly (AWZ2735)

1 2 3 4 5 6

To DAC assembly CN5
(To page 35)

To DAC assembly CN1
(To page 35)

POWER VR assembly

MIC assembly

HEAD PHONE assembly

To DISPLAY assembly CN704
(To page 30)

POWER assembly (AWZ2611)

SP TERMINAL assembly

SUB TRANS (1/2) assembly

To DISPLAY assembly CN703 (To page 30)

To DISPLAY assembly CN702
(To page 29)

FUSE assembly

TI POWER TRANSFORMER

SUB TRANS (2/2) assembly

To DISPLAY assembly CN701
(To page 29)

AC POWER CORD
AC 220V(HB)
240V(HB)
50/60Hz

735)

4.3 DISPLAY assembly (AWZ2743)

LCD DISPLAY assembly

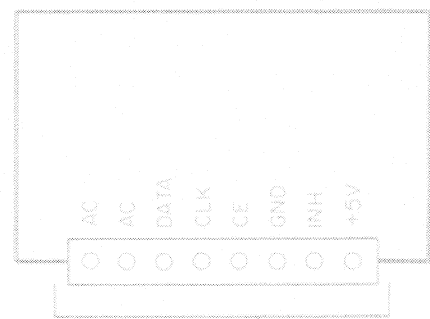

DISPLAY assembly (AWZ2743)

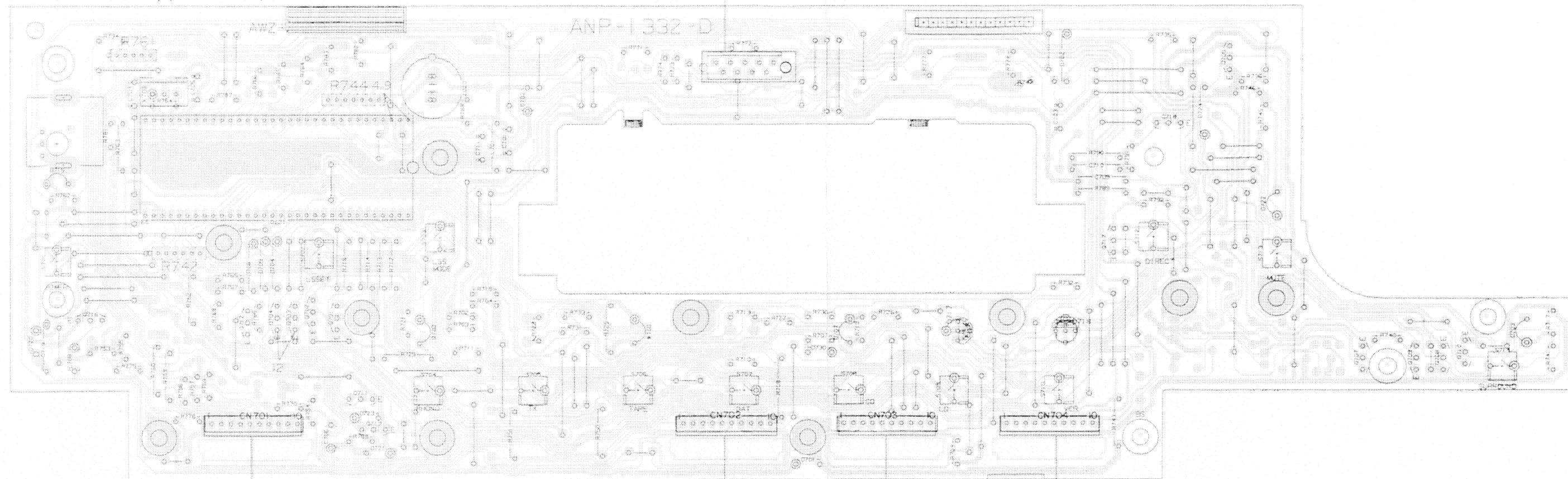

NOTE

1. This P.C.B. connection diagram is viewed from the parts mounted side.
2. The parts which have been mounted on the board can be replaced with those shown with the corresponding wiring symbols listed in the following Table.

P.C.B. pattern diagram indication	Corresponding part symbol	Part Name
Q504		Transistor
Q215		Radiator type transistor
Q203		Diode
R237		Resistor
C513		Capacitor (Polarity)
C516		Capacitor (Non-polarity)

Others

P.C.B. pattern diagram indication	Part Name
IC	IC
S	Switch
RY	Relay
L	Coil
F	Filter
VR	Variable resistor or Semi-fixed resistor

3. The capacitor terminal marked with ⊕ (double circles) shows negative terminal.
4. The diode terminal marked with ⊕ (double circles) shows cathode side.
5. The transistor terminal to which E is affixed shows the emitter.

Q716 IC701 Q712 Q701-Q704 Q711 Q713

Q717 Q718 Q705 Q707 Q708-Q710

To AF assembly CN101 (To page 22)

To AF assembly CN102 (To page 22)

To AF assembly CN103 (To page 22)

To AF assembly CN104 (To page 22)

1 2 3 4 5 6

A

B

C

D

A

B

C

D

DISPLAY assembly (AWZ2743)

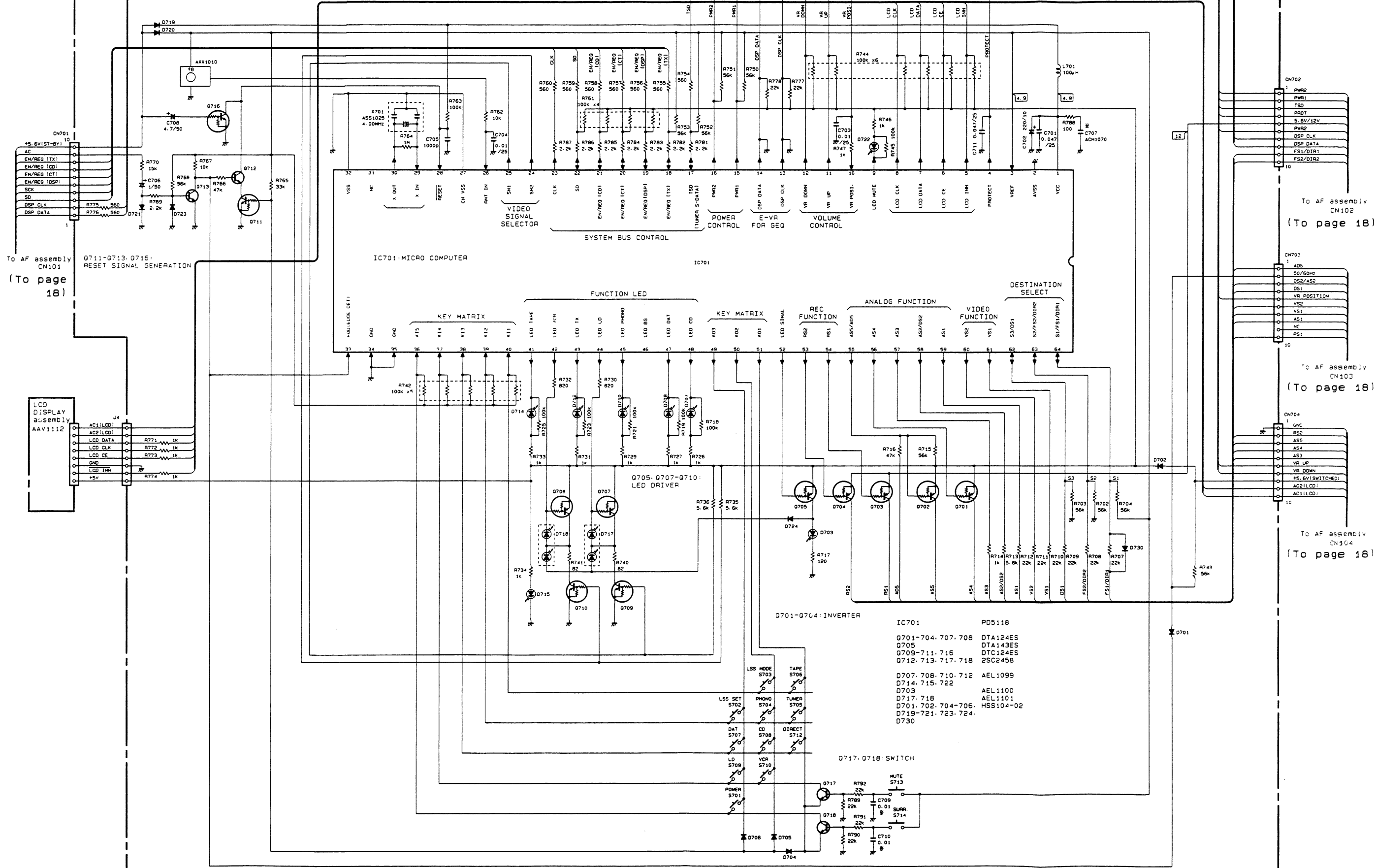

To AF assembly CN101 (To page 18)

Q711-Q713, Q715: RESET SIGNAL GENERATION

LCD DISPLAY assembly AAV1112

AC1(LCD)
AC2(LCD)
LCD DATA
LCD CLK
LCD CE
LCD IMH
+5V

R771 1k
R772 1k
R773 1k
R774 1k

To AF assembly CN102 (To page 18)

PMR2
TSO
PRDT
5.6V/12V
PMR2
DSP CLK
DSP DATA
FS1/DIR1
FS2/DIR2

To AF assembly CN103 (To page 18)

AD5
50/60Hz
DS1
VR POSITION
VS2
VS1
AS1
PS1

To AF assembly CN104 (To page 18)

LMC
RS2
AS5
AS4
AS3
VR UP
VR DOWN
+5.6V(SWITCHED)
AC2(LCD)
AC1(LCD)

- IC701 P05118
- Q701-Q704, 707, 708 DTA124ES
 - Q705 DTA143ES
 - Q709-711, 716 DTC124ES
 - Q712, 713, 717, 718 2SC2458
- Q707, 708, 710, 712 AEL1099
- D714, 715, 722 AEL1100
 - D703 AEL1100
 - D717, 718 AEL1101
 - D701, 702, 704-706, HSS104-02
 - D719-721, 723, 724, D730

Q717, Q718: SWITCH

1 2 3 4 5 6

4.4 DAC assembly (AWK1274)

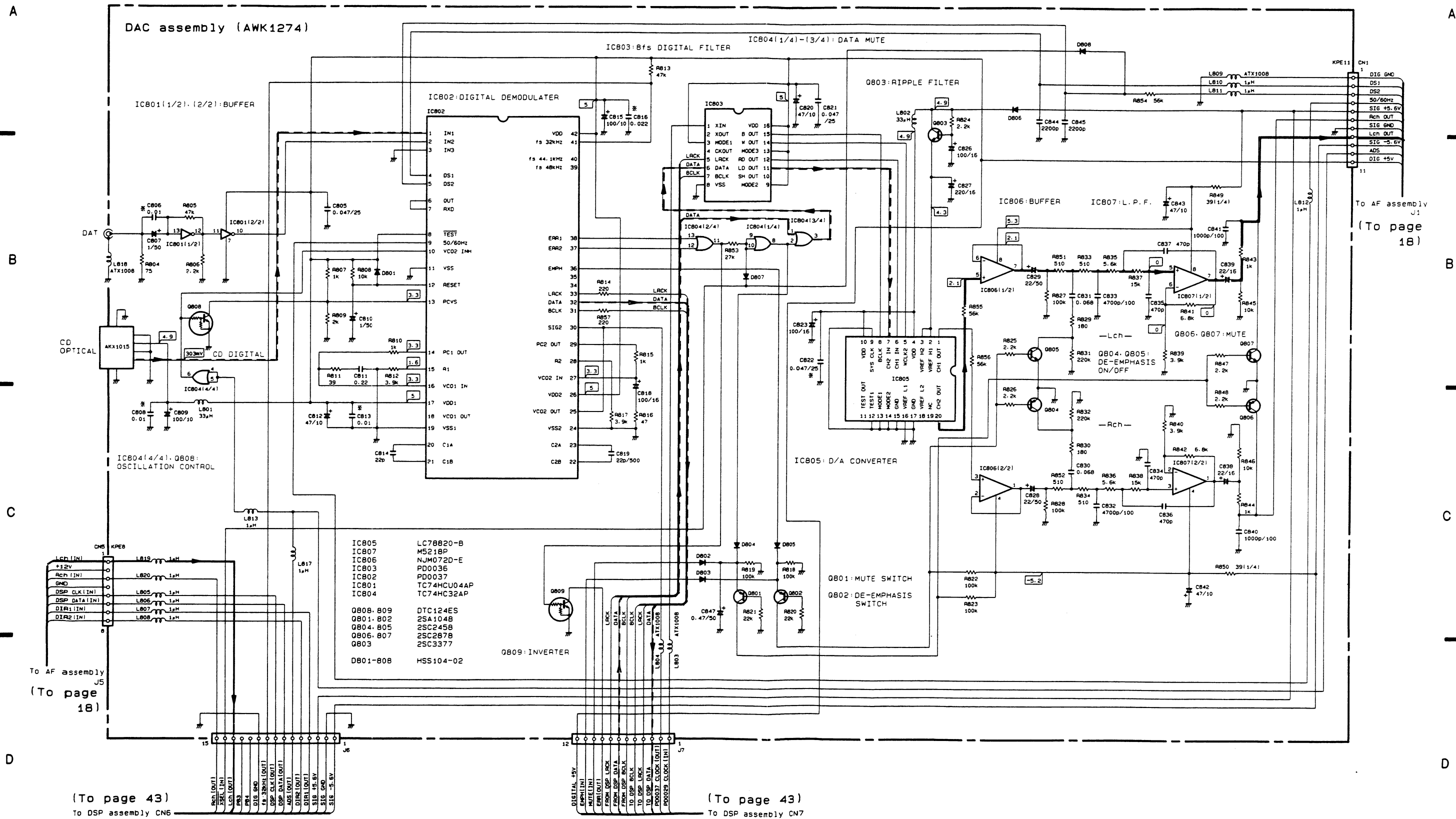

- NOTE
1. This P.C.B. connection diagram is viewed from the parts mounted side.
 2. The parts which have been mounted on the board can be replaced with those shown with the corresponding wiring symbols listed in the following Table.

P.C.B. pattern diagram indication	Corresponding part symbol	Part Name
Q504		Transistor
Q215		Radiator type transistor
Q203		Diode
R237		Resistor
C413		Capacitor (Polarity)
C518		Capacitor (Non-polarity)

Others

P.C.B. pattern diagram indication	Part Name
IC	IC
S	Switch
RV	Relay
L	Coil
F	Filter
VR	Variable resistor or Semi-fixed resistor

3. The capacitor terminal marked with ⊖ (double circles) shows negative terminal.
4. The diode terminal marked with ⊕ (double circles) shows cathode side.
5. The transistor terminal to which E is affixed shows the emitter.

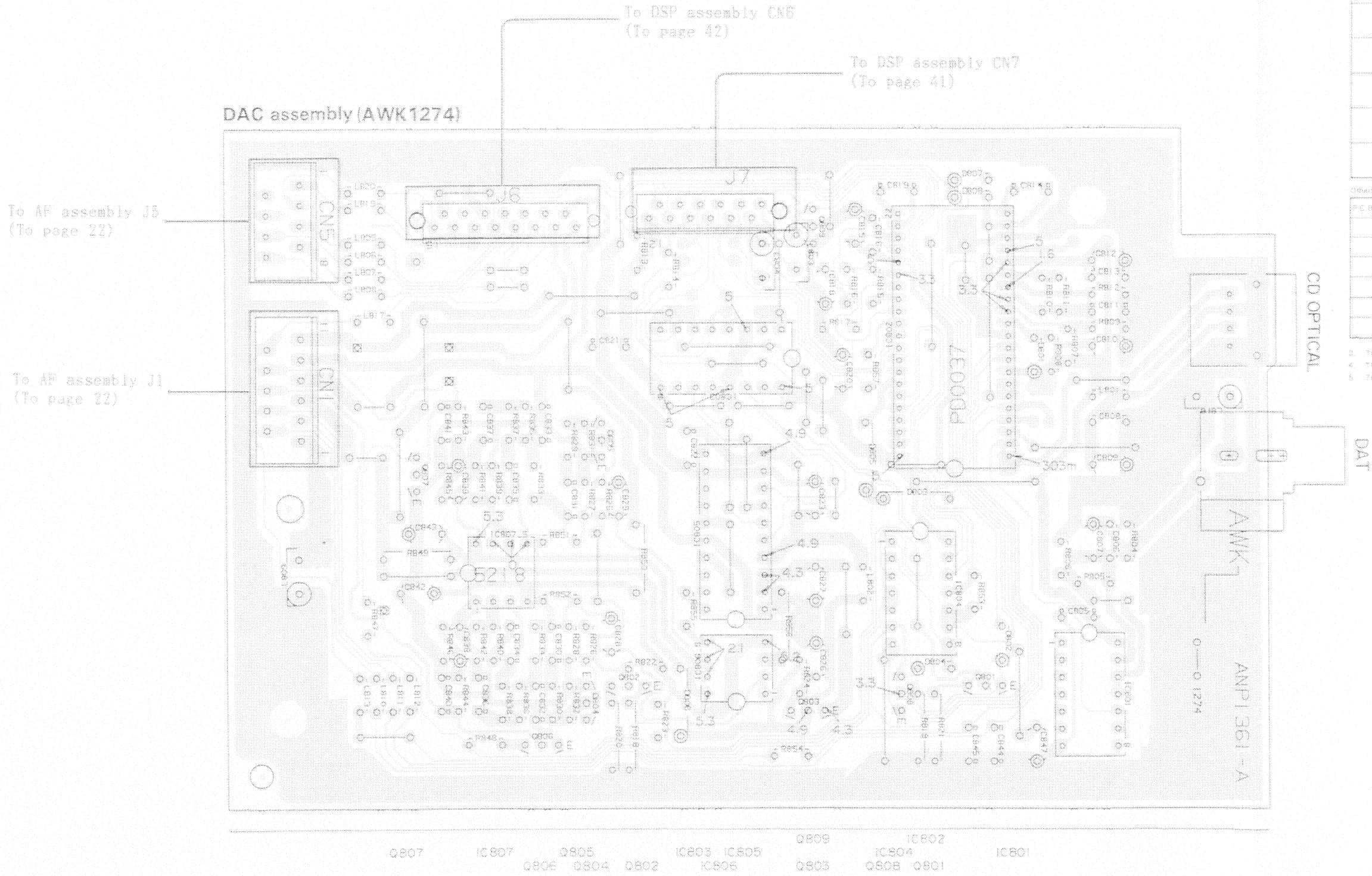

Q807 IC807 Q805 Q804 Q802 IC803 IC805 Q809 IC802 IC804 IC801
 Q806 Q804 Q802 IC806 Q803 Q808 Q801

4.5 DSP assembly (AWK1231)

- NOTE
1. This P.C.B. connection diagram is viewed from the parts mounted side.
 2. The parts which have been mounted on the board can be replaced with those shown with the corresponding wiring symbols listed in the following Table.

P.C.B. pattern diagram indication	Corresponding part symbol	Part Name
		Transistor
		Radiator type transistor
		Diode
		Resistor
		Capacitor (Polarity)
		Capacitor (Non-polarity)

Others

P.C.B. pattern diagram indication	Part Name
IC	IC
S	Switch
RY	Relay
L	Coil
F	Fuse
VR	Variable resistor or Semi-fixed resistor

3. The capacitor terminal marked with ⊖ (double circles) shows negative terminal.
4. The diode terminal marked with ⊖ (double circles) shows cathode side.
5. The transistor terminal to which E is affixed shows the emitter.

DSP assembly (AWK1231)

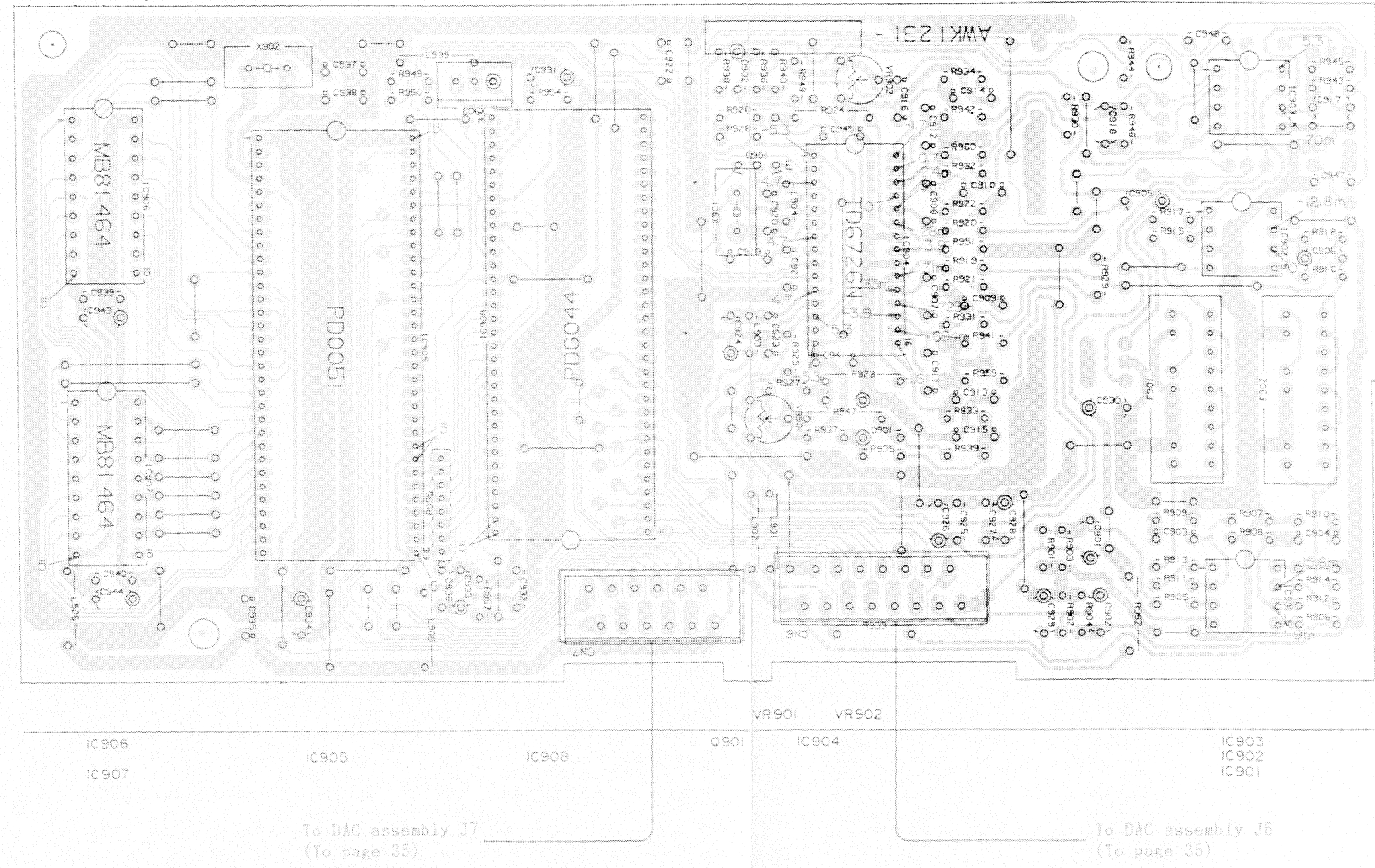

DSP assembly (AWK1231)

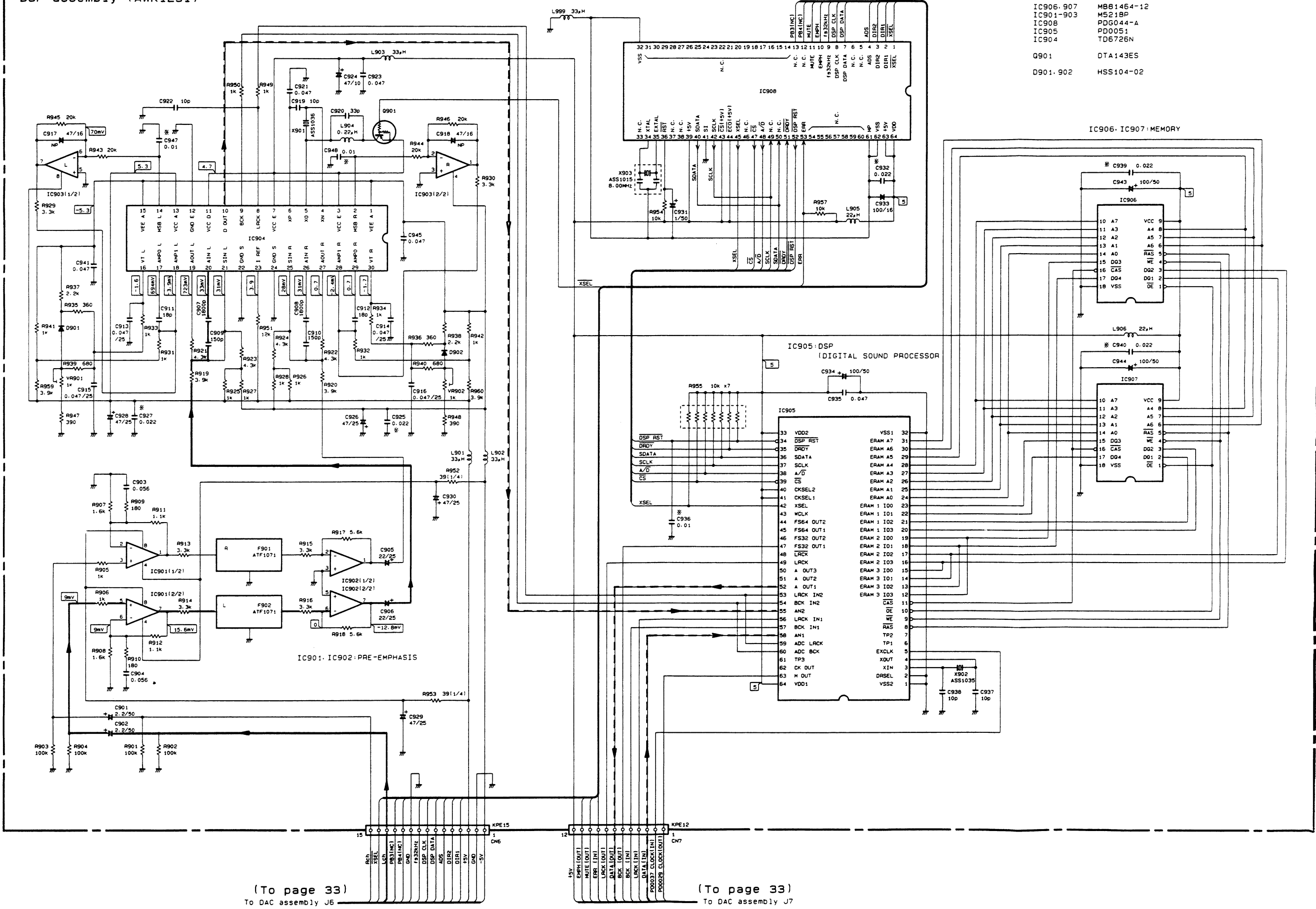

- IC906: 907 MB81464-12
- IC901-903 M5218P
- IC908 PDG044-A
- IC905 PD0051
- IC904 TD6726N
- Q901 DTA143ES
- D901: 902 HSS104-02

(To page 33)
To DAC assembly J6

(To page 33)
To DAC assembly J7

5. BLOCK DIAGRAM

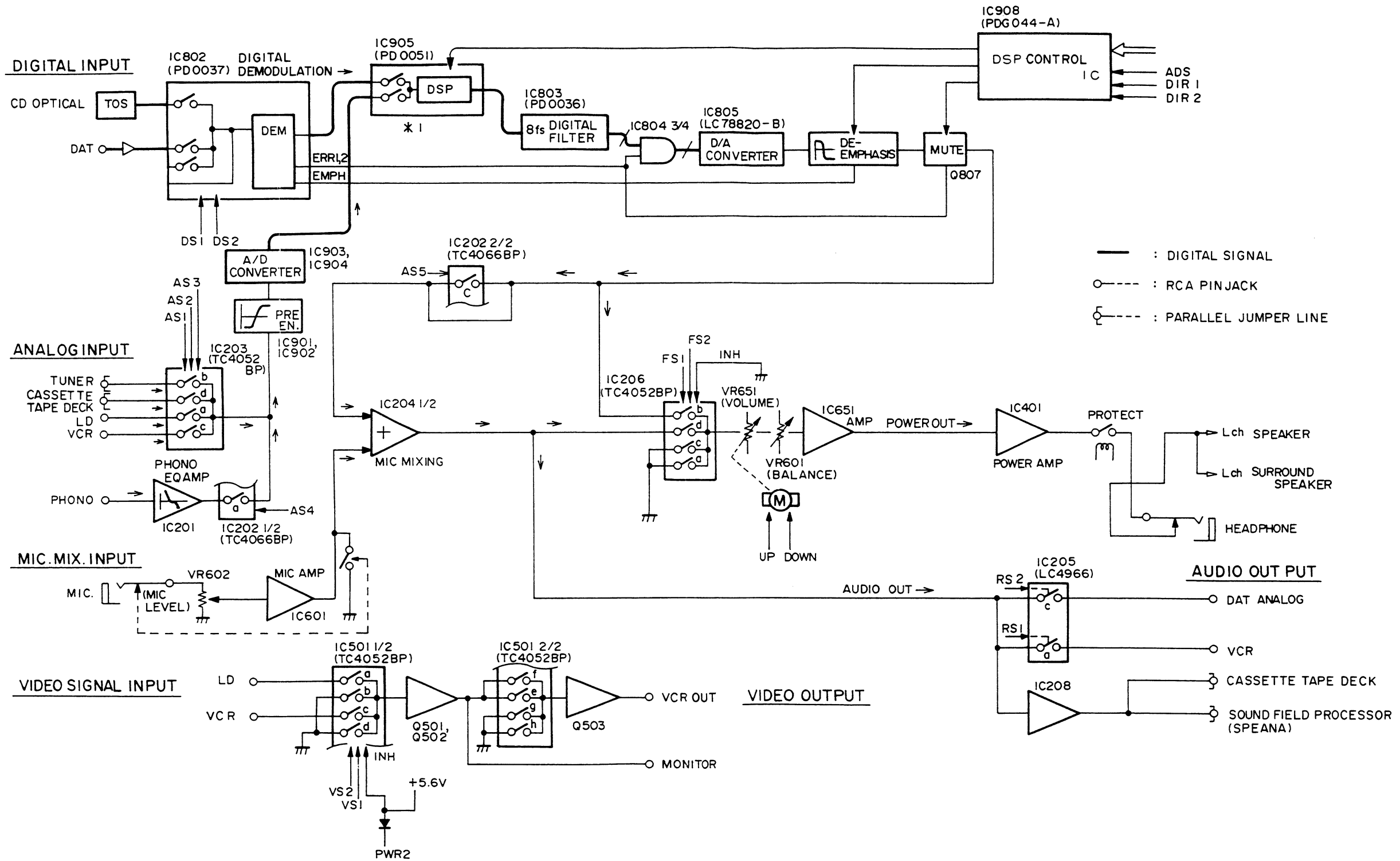

NOTE : The audio system uses only the Left channel (Lch) signal.

* 1: DSP processing is not performed in IC905 during direct mode.
 DSP : Digital Sound Processor

6. ADJUSTMENTS

1. If the SP-Z560 (sound field processor) is connected to the A-Z560, disconnect them. (This makes DSP processing in the A-Z560 flat.)
2. Input 1kHz/600mV to LD INPUT AUDIO Lch and Rch, then turn function to LD, followed by turning the main VR into the center position.
3. Adjust the VR901 (Rch) and VR902 (Lch) until the distortion of the Lch and Rch is minimized (0.15% or less) at the speaker output.

6. RÉGLAGE

1. Si le SP-Z560 (processeur de champ d'ambiance) est connecté au A-Z560, les déconnecter. (Ceci neutralise le traitement DSP dans le A-Z560.)
2. Entrer 1kHz/600mV aux bornes gauche et droite d'entrée audio LD (LD INPUT AUDIO), mettre le sélecteur de fonction sur "LD", suivi du réglage de la résistance variable (VR) principale à la position centrale.
3. Régler VR901 (D) et VR902 (G) jusqu'à ce que la distorsion des canaux gauche et droit soit réduite (0.15% ou moins) à la sortie des haut-parleurs.

6. AJUSTE

1. Si el SP-Z560 (procesador de campo sonoro) está conectado al A-Z560, desconéctelos. (De este modo el procedo DSP en el A-Z560 será plano.)
2. Introduzca 1kHz/600mV en los canales izquierdo y derecho de INPUT AUDIO del LD, cambie entonces la función a LD, y gire luego la VR principal a la posición central.
3. Ajuste la VR901 (canal derecho) y VR902 (canal izquierdo) hasta que la distorsión de los canales izquierdo y derecho se minimice (0.15% o menos) en la salida del altavoz.

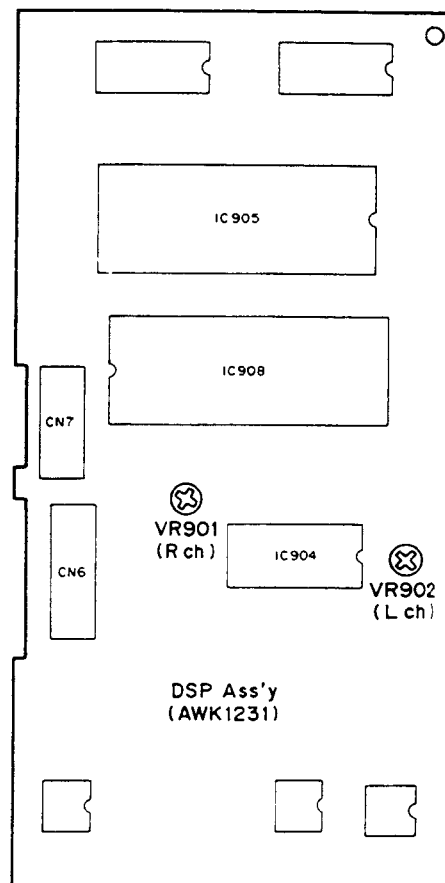

Fig. 6-1 Adjustment location

Fig. 6-1 Emplacements de réglage

Fig. 6-1 Puntos de ajustes

7. IC INFORMATION

7.1 PDG044 – A (DSP control IC)

• Terminal function

No.	Terminal name	I/O	Function	Active
1	XSEL	O	Inverted output of XSEL	H/L
2	DIR1	I	DIRECT ON/OFF detection input	H/L
3	DIR2	I		
4	ADS	I	ANALOG/DIGITAL detection input (H: ANALOG)	H/L
5	N.C.	I	Not used	—
6	N.C.	O	Not used	—
7	DSP DATA	I	DATA input from micro computer (PD3141) used as sound field processor	H/L
8	DSP CLK	I	CLK input from micro computer (PD3141) used as sound field processor	H/L
9	fs 32kHz	I	32kHz SAMPLING frequency input	H/L
10	EMPH	O	EMPHASIS ON/OFF output	H/L
11	MUTE	O	MUTE ON/OFF output	H
12	N.C.	O	Not used	—
13	N.C.	O	Not used	—
14	N.C.	O	Not used	—
15	N.C.	O	Not used	—
16	N.C.	O	Not used	—
17	N.C.	O	Not used	—
18	N.C.	O	Not used	—
19	N.C.	O	Not used	—
20	N.C.	O	Not used	—
21	N.C.	O	Not used	—
22	N.C.	O	Not used	—
23	N.C.	O	Not used	—
24	N.C.	O	Not used	—
25	N.C.	O	Not used	—
26	N.C.	O	Not used	—
27	N.C.	O	Not used	—
28	N.C.	O	Not used	—
29	N.C.	O	Not used	—
30	N.C.	O	Not used	—
31	N.C.	O	Not used	—

No.	Terminal name	I/O	Function	Active
32	Vss	—	GND	—
33	N.C.	O	Not used	—
34	XTAL	O	Connected to the 8MHz ceramic resonator	—
35	EXTAL	I		
36	$\overline{\text{RST}}$	I	RESET terminal	L
37	N.C.	O	Not used	—
38	N.C.	O	Not used	—
39	$\overline{\text{ECI}}$	I	+5V	—
40	S DATA	O	DATA output to DSP IC (PD0051)	H/L
41	SI	I	GND	—
42	$\overline{\text{SCLK}}$	O	CLOCK output to DSP IC (PD0051)	H/L
43	$\overline{\text{CS}}$	I	+5V	—
44	$\overline{\text{EC0}}$	I	+5V	—
45	XSEL	O	Output for XSEL switching	H/L
46	N.C.	O	Not used	—
47	$\overline{\text{CS}}$	O	CS output to DSP IC (PD0051)	L
48	$\overline{\text{A/D}}$	O	Out put to DSP IC(PD0051)for switching between ADDRESS and DATA	H/L
49	SCLK	O	Not used (This pin is not used although SCLK signals are input here.)	—
50	SDATA	O	Not used (This pin is not used although SDATA signals are input here.)	—
51	$\overline{\text{DRDY}}$	I	DRDY input from DSP IC (PD0051)	H/L
52	$\overline{\text{DSP RES}}$	O	RESET output to DSP IC (PD0051)	L
53	ERROR	I	ERROR input for digital demodulator	H/L
54	N.C.	I	Not used	—
55	N.C.	O	Not used	—
56	N.C.	O	Not used	—
57	N.C.	O	Not used	—
58	N.C.	O	Not used	—
59	N.C.	O	Not used	—
60	N.C.	O	Not used	—
61	MP	I	GND	—
62	Vss	—	GND	—
63	+5V	—	+5V	—
64	Vdd	—	+5V	—

Note) I: CMOS input
O: CMOS output

7.2 PD5118 (System control micro computer)

7.2.1 Terminal function

No.	Terminal name	Function	Active	I/O															
1	Vcc	Vcc	—	—															
2	AVss	GND	—	—															
3	VREF	STB +5V	—	I															
4	PROTECT	Protection relay control (H: Relay ON)	H	O															
5	LCD INH	LCD display assembly control bus line initialization	H/L	O															
6	LCD CE	LCD display assembly control bus line chip enable	H/L	O															
7	LCD DATA	LCD display assembly control bus line data	H/L	O															
8	LCD CLK	LCD display assembly control bus line clock	H/L	SO															
9	LED MUTE	MUTE LED control (L: ON)	L	O															
10	VR POSITION	This pin detects the VR position (A/D conversion of analog input) and stores it in the memory. The position is used for servo-control of the motor in the LS mode when the power is turned on after the timer record.	—	I															
11	VR UP	These pins are used for controlling the volume motor via VOL UP/DOWN commands from the remote controller. <table border="1" style="margin: 10px auto;"> <thead> <tr> <th>Pin 11</th> <th>Pin 12</th> <th>MOTOR Status</th> </tr> </thead> <tbody> <tr> <td>0</td> <td>0</td> <td>Stop (in the normal mode)</td> </tr> <tr> <td>0</td> <td>1</td> <td>DOWN</td> </tr> <tr> <td>1</td> <td>0</td> <td>UP</td> </tr> <tr> <td>1</td> <td>1</td> <td>Stop (except for immediately after the prohibited mode RESET)</td> </tr> </tbody> </table>	Pin 11	Pin 12	MOTOR Status	0	0	Stop (in the normal mode)	0	1	DOWN	1	0	UP	1	1	Stop (except for immediately after the prohibited mode RESET)	H/L	O
Pin 11	Pin 12		MOTOR Status																
0	0		Stop (in the normal mode)																
0	1		DOWN																
1	0	UP																	
1	1	Stop (except for immediately after the prohibited mode RESET)																	
12	VR DOWN																		
13	E-VR CLK																		
14	E-VR DATA																		
13	E-VR CLK	Not used	—	O															
14	E-VR DATA																		
15	PWR 1	Power relay ON/OFF (L: ON)	L	O															
16	PWR 2	Power electric (Q553) switch ON/OFF (L: ON)	L	O															
17	TSD	System bus control serial data for the tuner	H/L	I/O															
18	EN/REQ (TX)	System bus control enable/request for the tuner	H/L	I/O															
19	EN/REQ (DSP)	System bus control enable/request for the sound field processor	H/L	I/O															
20	EN/REQ (CT)	System bus control enable/request for the tape deck	H/L	I/O															
21	EN/REQ (CD)	System bus control enable/request for the CD player	H/L	I/O															
22	SD	System bus control serial data	H/L	I/O															
23	SCK	System bus control serial clock	H/L	O															

No.	Terminal name	Function	Active	I/O
24	SM 2	LD LED and VCR LED control for VIDEO SIGNAL SELECTOR	H/L	O
25	SM 1			
26	RMT IN	Remote control signal input (L: When receiving)	L	I
27	CN Vss	GND	—	—
28	RESET	RESET input	L	I
29	X IN	Connected to the 4MHz crystal resonator	—	I
30	X OUT		—	O
31	NC	Not used	—	—
32	Vss	GND	—	—
33	POD	EDGE DET (It switches to the back-up mode when 50/60Hz signals are detected or there are no input pulses for more than 50msec.)		I
34	GND	GND	—	I
35				
36	KI5	Key matrix input	L	I
37	KI4		L	I
38	KI3		L	I
39	KI2		L	I
40	KI1		L	I
41	LED TAPE	TAPE IND LED control (L: ON)	L	O
42	LED VCR	VCR IND LED control (L: ON)	L	O
43	LED TX	TUNER IND LED control (L: ON)	L	O
44	LED LD	LD IND LED control (L: ON)	L	O
45	LED PHONO	PHONO IND LED control (L: ON)	L	O
46	LED BS	Not used	—	O
47	LED DA	DAT IND LED control (L: ON)	L	O
48	LED CD	CD IND LED control (L: ON)	L	O
49	KO3	Key matrix output		O
50	KO2			O
51	KO1			O
52	LED SIMAL	VIDEO SIGNAL SELECTOR LED ON/OFF control (L: ON)	L	O
53	RS2	Signal control (See figure 7-1)	H/L	O
54	RS1		H/L	O

No.	Terminal name	Function	Active	I/O
55	AS5/ADS	Signal control (See figure 7-1)	H/L	O
56	AS4		H/L	O
57	AS3		H/L	O
58	AS2/DS2		H/L	O
59	AS1		H/L	O
60	VS2		H/L	O
61	VS1		H/L	O
62	S3/DS1	Signal control (See figure 7-1), These pins are also used as a model selector for A-Z560, A-Z460 and A-Z360 (See below).	H/L	I/O
63	S2/FS2/DIR2		H/L	I/O
64	S1/FS1/DIR1		H/L	I/O

• VIDEO SIGNAL SELECTOR

Pin No.	25	24	52	Function and LED status
Name	SM1	SM2	LED SIMAL	
Logic	L	L	H	For V-SEL OFF, the LED in each video system lights red according to the function
	L	H	L	For V-SEL ON, the LED of the VCR lights orange
	H	L	L	For V-SEL LD ON, the LED of the LD lights orange

• Model select

Pin No.	Pin 64	Pin 63	Pin 62
Model name	S1	S2	S3
A-Z560	H	L	L
A-Z460 and A-Z360	H	H	L

H: Pull up
 L: Pull down
 In this case, Pins 62-64 function as an input port.

7.2.2 Signal control circuit

As shown in previous tables, the pins 53–64 in the A-Z560 of the system control micro computer PD5118 are used to control (or switch ON/OFF) each signal. To confirm which signal controls which IC, refer to figure 7–1.

The control of ICs is summarized in the following logic tables. The logic in the tables refers to input values for each controlled IC instead of the output values of the PD5118.

Refer to each circuit diagram for switch names (a, b and c, etc.) in the switch status of these tables.

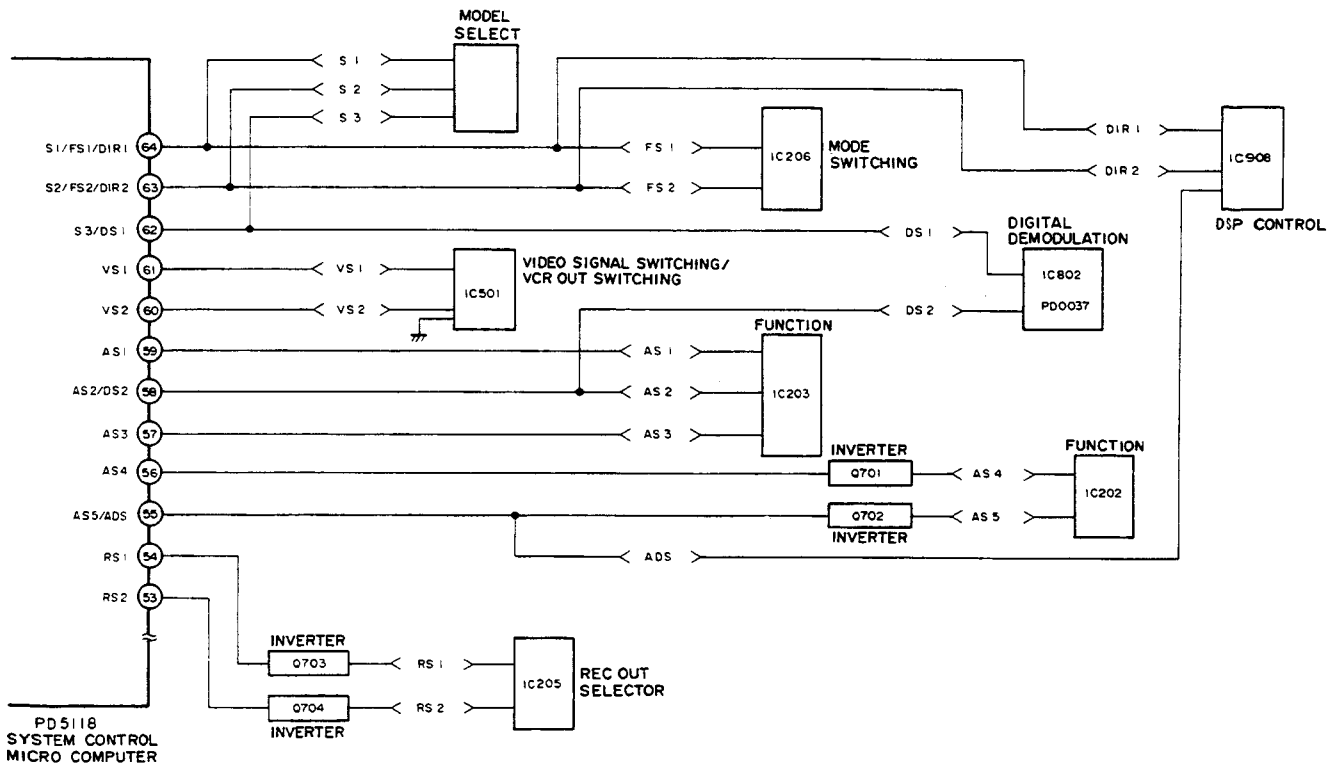

Figure 7–1 Circuit diagram of signal control pins

- IC501 (TC4052BP) (1/2) : Switching of VIDEO signals
- IC501 (TC4052BP) (2/2) : Switching of VCR OUT

Pin No.	6	10	9	Signals of MONITOR OUT pin (※2)	Signals of VCR OUT pin (※2)	Function
Name	INT	VS1	VS2			
Logic	L	L	L	LD (a: ON)	LD (e: ON)	LD
	L	L	H	Mute ON (d: ON)	Mute ON (g: ON)	Other than LD and VCR.
	L	H	H	VCR (c: ON)	Mute ON (h: ON)	VCR
	H	×	×	Mute ON (a-d: OFF)	Mute ON (e-f: OFF)	POWER OFF (※1)

※1: To prevent screen pop when the power is turned OFF, MONITOR and VCR OUT are muted.
 ※2: Switching status of IC is shown in parenthesis.

• IC203 (TC4052BP) Function

Pin No.	6	10	9	Switch status		Function	Remarks
				Lch	Rch		
Terminal name	AS3	AS1	AS2				
	L	L	L	a:on	e:on	LD	
	L	H	L	b:on	f:on	TUNER	
	L	L	H	d:on	h:on	TAPE DECK	
	L	H	H	c:on	g:on	VCR	
	H	H	L	Switches, a-g, go to OFF		CD	Selection in the IC802
	H	H	H			DAT	
H	H	H				PHONO	Selection in the IC202

• IC206 (IC4052BP) Switching of modes

Pin No.	6	10	9	Switch status		Mode		Signal to volume
				Lch	Rch	Direct	Mute	
Name	INH ※1	FS1	FS2					
	L	L	L	d: ON	h: ON	OFF	OFF	Signals after MIC MIX
	L	H	L	a: ON	e: ON	OFF	ON	Signals are muted
	L	L	H	b: ON	f: ON	ON	OFF	Signals before MIC MIX
Logic	L	H	H	c: ON	g: ON	ON	ON	Signals are muted

※1: INH is always connected to the ground line.

• **IC202 (TC4066BP) Function**

PHONO ON/OFF

Pin No.	5, 13	Switch status		Function
Name	AS4	Lch	Rch	
Logic	H	a: on	b: on	PHONO
	L	a: off	b: off	Others

D/A CONVERTER OUT ON/OFF

Pin No.	6, 12	Switch status		Function
Name	AS5 ※1	Lch	Rch	
Logic	H	c: on	d: on	CD or DAT
	L	c: off	d: off	Other than CD and DAT

※1: As for A-Z560, the switching status driven by these signals is independent of the circuit.

• **IC205 (LC4966) Audio REC output selection**

VCR OUT selection

Pin No.	5, 6	Switch status		Function	Output signal from the VCR OUT pin
Name	RS1	Lch	Rch		
Logic	H	a: on	b: on	Other than VCR	Any selected signal other than the VCR
	L	a: off	b: off	VCR	No output from the VCR OUT pin

DAT OUT selection

Pin No.	12, 13	Switch status		Function	Output signal from the DAT OUT pin
Name	RS2	Lch	Rch		
Logic	H	c: on	d: on	Other than DAT	Any selected signal other than DAT
	L	c: off	d: off	DAT	No output from the DAT OUT pin

• **IC802 (PD0037) Digital input signal selection**

Pin No.	4	5	Function
Name	DS1	DS2	
Logic	H	L	CD
	L	H	DAT (plus PHONO, VCR and TAPE) ※1
	L	L	(LD, TUNER) ※1

※1: Functions in parentheses are analog input values which are independent of switching of the PD0037.

- **IC908 (PDG044) DSP control IC**

Direct detection

- This IC detects DIRECT ON/OFF, and does not generate DSP signal processing when DIRECT ON.

Pin No.	2	3	Mode	
Name	DIR 1	DIR 2	Direct	Mute
Logic	L	L	OFF	OFF
	H	L	OFF	ON
	L	H	ON	OFF
	H	H	ON	ON

Input selection

- In the PD0051, digital signals from PHONO, LD, TUNER, VCR and TAPE in the analog function system are input to pin 55 (AN2), while signals from CD and DAT in the digital system are input to pin 58 (AN1).

This input selection is made by ADS signals.

Pin No.	4	Function
Name	ADS	
Logic	L	CD, DAT
	H	Other than CD and DAT

8. FOR HE TYPE

CONTRAST OF MISCELLANEOUS PARTS

The A-Z560/HE type is the same as the A-Z560/HB type with the exception of the following sections.

Mark	Symbol & Description	Part No.		Remarks
		A-Z560/HB type	A-Z560/HE type	
	SUB TRANS assembly	Non supply	Non supply	
⚠	FU1 Fuse (T2.5A/250V)	AEK-512	AEK-403	
⚠	FU2 Fuse (T2A/250V)	AEK-511	AEK-017	
⚠	FU3, FU4 Fuse (T1.6A/250V)	AEK-510	AEK-405	
⚠	AC power cord	ADG-051	ADG1019	
	Operating instructions (English)	ARB1221	
	Operating instructions (Dutch, Swedish, Spanish, Portuguese)	ARC1178	
	Operating instructions (English, German, French, Italian)	ARE1139	

SUB TRANS assembly

The SUB TRANS assembly (A-Z560/HE type) is the same as the SUB TRANS assembly (A-Z560/HB type) with the exception of the following sections.

Mark	Symbol & Description	Part No.		Remarks
		HB type	HE type	
⚠	1P AC outlet	AKP1035	AKP1034	

9. PANEL FACILITIES

Front panel

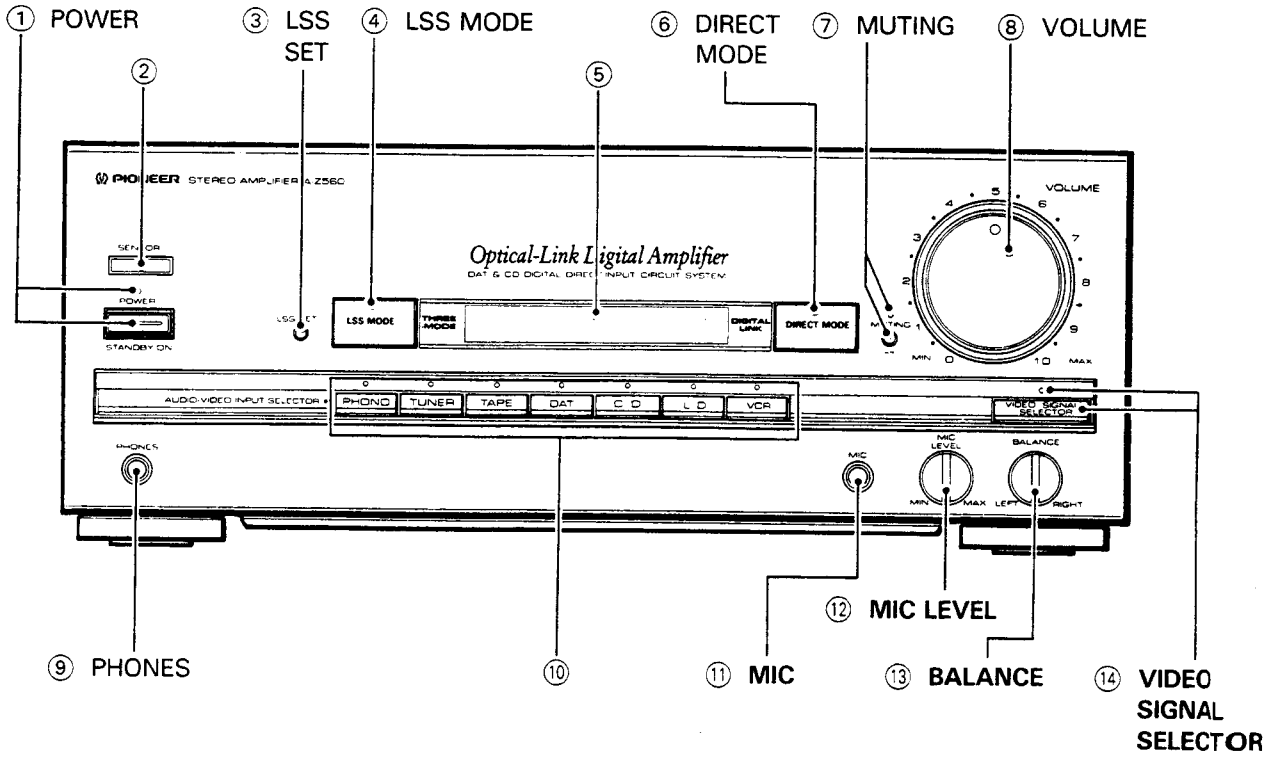

Display section

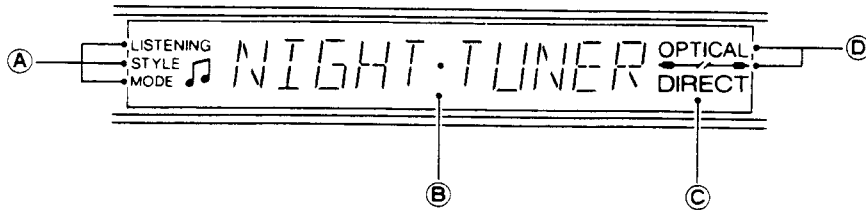

① POWER STANDBY/ON switch/indicator

This is the switch for electric power.

ON When set to the ON position, power is supplied and the unit becomes operational.

STANDBY When set to the STANDBY position, the main power flow is cut and the unit is no longer fully operational. A minute flow of power feeds the unit to maintain operation readiness.

The indicator above the switch lights when the power is ON, and goes out during STANDBY.

During STANDBY, the tuner display only shows the time on the clock.

② Remote sensor**③ LSS SET switch**

Use to operate the Listening Style Selector memory.

④ LSS MODE switch

Use to recall the Listening Style Selector.

⑤ Display section**⑥ DIRECT MODE switch**

Use this when you want by-pass sound quality adjustment circuitry and listen to a CD or DAT in the direct mode.

⑦ MUTING switch/indicator

Use when you want to temporarily cut sound during playback. Press again to return to the previous volume level.

⑧ VOLUME control**⑨ PHONES jack**

For stereo headphones.

NOTE:

There is no output from the speakers when headphones are plugged into PHONES jack.

⑩ Input selector switches/indicators**[PHONO]**

Press to play records on a turntable connected to the PHONO input jacks.

[TUNER]

Press to listen to radio broadcast.

[TAPE]

Press to listen to cassette tape.

[DAT]

Press to listen to a DAT playing on a digital audio tape deck connected to the DAT jacks.

[CD]

Press to listen to compact disc.

[LD]

Press to play an LD on a video disc player connected to the LD input jacks.

[VCR]

Press to play a tape on a video cassette recorder connected to the VCR jacks.

⑪ MIC (microphone) jack

This is a standard jack for connecting a microphone.

NOTE:

Mike mixing is not possible when CD DIRECT or DAT DIRECT are ON.

⑫ MIC LEVEL control

Used for adjusting the volume of microphone.

⑬ BALANCE control

Used for changing the balance between left and right channels. Usually set this control to the center position.

⑭ VIDEO SIGNAL SELECTOR switch/indicator

Pressing this switch lets you select video sources independent of those selected with the input selector switches. Each time you press it, the source changes.

A This lights during listening style selector operation.

B Information such as the component selected with the input selector switch and listening style selector position is displayed.

C This lights when you can select CD and DAT direct mode.

D This lights when you play a CD.

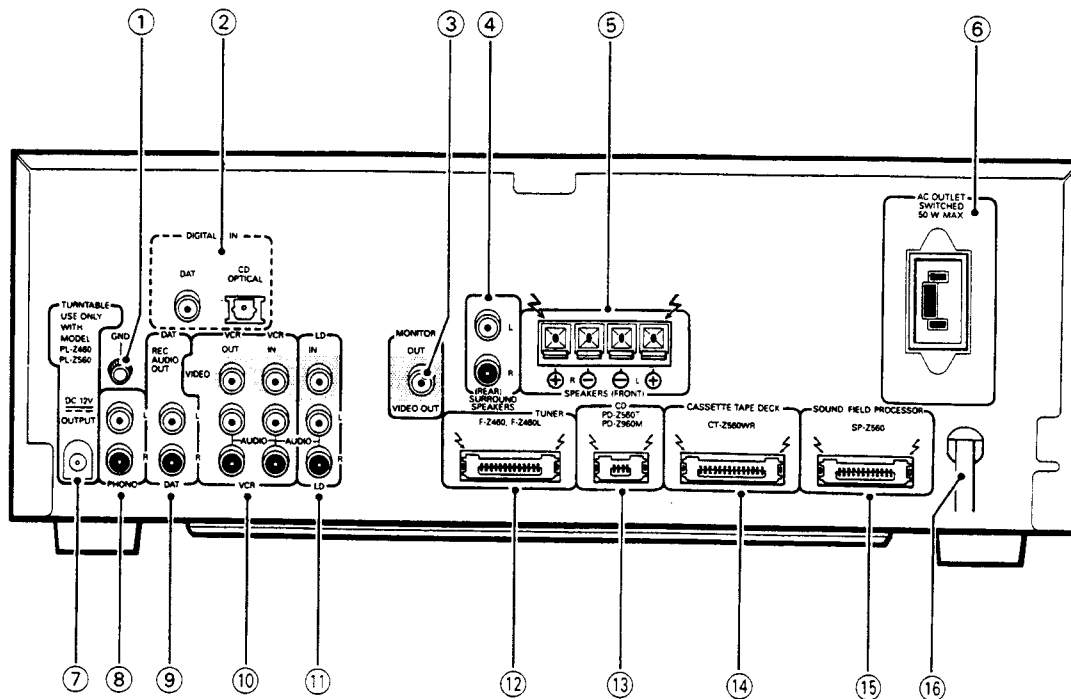

① Ground terminal (GND)

Connect this to the ground terminal on the turntable (except for PL-Z560).

② DIGITAL IN jacks

[DAT]

A digital audio tape deck's digital output jack (coaxial cable output) can be connected here.

Consult with your dealer to see if it's possible to connect your digital audio tape deck.

[CD]

Connect a CD player's OPTICAL OUT jack.

③ MONITOR OUT jack

You can connect a TV with a video input jack or monitor TV here. The picture from a video disc player or video cassette recorder connected to the video input jack is output.

④ SURROUND SPEAKERS jacks

Connect the Surround speaker systems.

NOTE:

Connect a speaker system having a nominal impedance of 16 Ω or more.

⑤ SPEAKERS terminals

L: Connect the left speaker system as seen from the listening position.

R: Connect the right speaker system as seen from the listening position.

NOTE:

Connect a speaker system having a nominal impedance ranging from 6 Ω to 16 Ω.

⑥ AC OUTLET (SWITCHED 50 W MAX)

Power supplied through this outlet is turned on and off by the amplifier's POWER switch. Total electrical power consumption of connected equipment should not exceed 50 W.

NOTE:

Do not connect appliances with high power consumption such as heaters, irons, or television sets to the AC OUTLET in order to avoid overheating or fire risk.

This can cause the amplifier to malfunction.

⑦ TURNTABLE (DC 12V OUTPUT) jack

This jack supplies power to the turntable.

⑧ PHONO input jacks

Connect the output cord of the turntable to these jacks.

⑨ DAT REC OUT jacks

Connect to audio input jacks of the digital audio tape deck.

⑩ VCR jacks

IN: Connect to the audio and video output jack of VCR.

OUT: Connect to audio and video input jacks of VCR.

⑪ LD input jacks

Connect to audio and video output jacks of the videodisc player.

⑫ TUNER jack

Connect the tuner cord here.

⑬ CD jack

Connect the compact disc player cord here.

⑭ CASSETTE TAPE DECK jack

Connect the cassette deck cord here.

⑮ GRAPHIC EQUALIZER jack

Connect the sound field processor cord here.

⑯ Power cord

Connect this to the AC wall socket.