

Service Manual

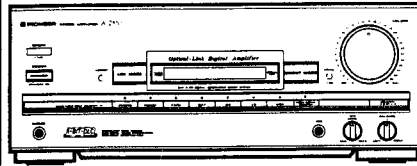

ORDER NO.
ARP2156

STEREO AMPLIFIER

A-Z570

MODEL A-Z570 HAS FOLLOWING VERSIONS :

Type	Power requirement	Export destination
HE	AC220V, 240V(switchable) *	European continent
HEWZIW	AC220V, 240V(switchable) *	Germany and Italy

* : Change the primary wiring.

- This manual is applicable to the A-Z570/HE and HEWZIW types.
- As to the HEWZIW type, refer to page 46.
- This product is a component of a system. As to the system composition, refer to the system manual.
- This product does not function properly when independent ; to avoid malfunctions, be sure to connect it to the prescribed system component, otherwise damage may result.
- Ce manuel pour le service comprend les explications de réglage en français.
- Este manual de servicio trata del método ajuste escrito en español.

CONTENTS

1. SPECIFICATIONS	2	5. ADJUSTMENTS	45
2. EXPLODED VIEWS, PACKING AND PARTS LIST	3	5. RÉGLAGE	45
3. P.C.B's PARTS LIST	7	5. AJUSTE	45
4. SCHEMATIC DIAGRAMS AND P.C.BOARD CONNECTION DIAGRAMS	13	6. FOR HEWZIW TYPE	46
		7. PANEL FACILITIES	61

1. SPECIFICATIONS

Amplifier Section

Continuous Power Output (DIN)	80 W + 80 W (1 kHz, T.H.D 1%, 8Ω)
Music power (DIN)	120 W + 120 W (1 kHz, T.H.D 1%, 8Ω)
D/A converter section	
Signal-to-Noise Ratio	More than 96 dB (EIAJ)
Dinamic range	More than 94 dB (EIAJ)
Frequency range	25 Hz to 20 kHz
Total Harmonic Distortion (1 kHz, 40 W, 8Ω)...	No more than 0.06% **
Input sensitivity	
PHONO (MM)	2.5 mV
MIC	0.25 mV
VCR, DAT	150 mV
LD	250 mV
Output level	
DAT, VCR	150 mV
MUTING	-∞

Power Supply/Miscellaneous

Power requirements	a.c.220 Volts~, 50/60 Hz
Power consumption	410 W
AC outlets switched (x 1)	50 W
Dimensions	360 (W) x 343 (D) x 135.5 (H) mm
Weight (without package)	8.8 kg

Accessories

Operating instructions	1
Remote control unit	1
Dry cell batteries "AA" (IEC R6/UM-3)	2

** Measured By Audio Spectrum Analyzer.

- Specifications and design subject to possible modification without notice due to improvement.

2. EXPLODED VIEWS, PACKING AND PARTS LIST

NOTES:

- Parts without part number cannot be supplied.
- Parts marked by "●" are not always kept in stock. Their delivery time may be longer than usual or they may be unavailable.
- The ▲ mark found on some component parts indicates the importance of the safety factor of the part. Therefore, when replacing, be sure to use parts of identical designation.

2.1 PARTS LIST

Mark	No.	Description	Part No.	Mark	No.	Description	Part No.
	1	VOL KNOB	AAAB1117		49	PLATE	AMR2138
	2	ROTARY KNOB	AAAB1130		50	WAIST RAIL BOARD	
	3	POWER BUTTON	AAAD1595		51	CHASSIS	
	4	BOTTON L	AAAD1596		52	REAR PANEL	
	5	BUTTON L	AAAD1597		53	BOTTOM PLATE	
	6	KIN BUTTON	AAAD1682		54	BONNET CASE	ANE1208
	7	FUNCTION BUTTON	AAAD1969		55	TRANS. HOLDER	
	8	BUTTON S	AAAD1970		56	HEAT SINK HOLDER	
	9	LENS L	AAAK1757		57	VOLUME HOLDER	
	10	LENS S	AAAK1758		58	HOLDER	
	11	LENS	AAAK1759		59	HOLDER A	
	12	PANEL	AAAK2115		60	HEAT SINK	
	13			61	HEAT SINK	
	14	NAME PLATE(PLASTIC)			62	GROUND PLATE	
	15			63	SHIELD CASE	
	16	SCREW (STEEL)	ABA-283		64	SHIELD COVER	
	17	SCREW	ABA-298		65	OPERATING INSTRUCTIONS	ARC1249
	18	SCREW (STEEL)	ABA1009			(Dutch, Swedish, Spanish, Portuguese)	
	19	SCREW (STEEL)	ABA1011		66	OPERATING INSTRUCTIONS	ARE1181
	20	SCREW	ABA1018			(English, German, French, Italian)	
	21	SCREW (STEEL)	ABA1047		67	COVER	AZN1993
	22	SCREW (STEEL)	ABA1050		68	
	23	SCREW (STEEL)	ABA1072		69	DAC ASSEMBLY	AWK1385
	24	SCREW	ABA1098		70	MIC ASSEMBLY	
	25	SPRING	ABH1032		71	HEAD PHONE ASSEMBLY	
▲	26	AC POWER CORD	ADG1019		72	SUB TRANS ASSEMBLY	
	27	CUSHION			73	POWER VR ASSEMBLY	
	28			74	RELAY ASSEMBLY	
	29	NYLON RIVET	AEC-471		75	SP TERMINAL ASSEMBLY	
	30	NYLON RIVET	AEC-510		76	FUSE ASSEMBLY	
	31	STRAIN RELIEF	AEC-882	●	77	DISPLAY ASSEMBLY	AWZ3362
	32	PCB SUPPORT		●	78	AF ASSEMBLY	AWZ3404
	33	CUSHION		●	79	POWER ASSEMBLY	AWZ2611
	34	PCB SPACER		●	80	STANDBY ASSEMBLY	AWZ3505
	35			81	DSP ASSEMBLY	AWK1445
	36			82	REMOTE CONTROLLER	AXD1195
	37	SPACER				(CU-AZ021)	
	38	BATTERY (R6P,AA)			83	SCREW	BBZ26P060FMC
	39	FRONT PAD	AHA1272		84	SCREW	BBZ26P080FMC
	40	REAR PAD	AHA1273		85	NUT	NK90FUC
	41	PACKING CASE	AHD2009		86	FOOT(PLASTIC)	RXA1276
	42	LITERATURE BAG			87	
	43	PACKING SHEET	AHG1016	▲	88	FU1 FUSE(T2.5A)	AEK-403
	44	TERMINAL SCREW		▲	89	FU2 FUSE(T2A)	AEK-017
	45	MOUNTING PLATE		▲	90	FU3 FUSE(T1.6A)	AEK-405
	46	FRONT PANEL ASSY	AMB1763	▲	91	FU4 FUSE(T1.6A)	AEK-405
	47	PCB MOULD		▲	92	T1 POWER TRANSFORMER	ATS1227
	48	LEG ASSY(S)	AMR1937	▲	93	V LCD	AAV1112

2. 3 PACKING

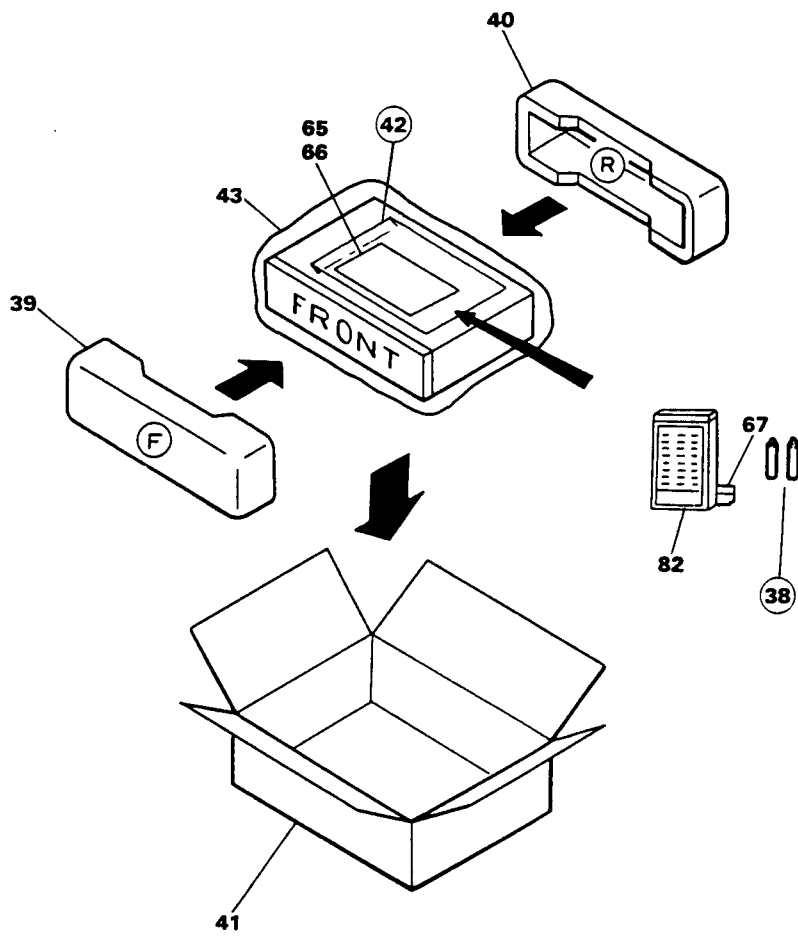

A

B

C

D

3. P.C.B's PARTS LIST

NOTES :

- Parts without part number cannot be supplied.
- Parts marked by "⊙" are not always kept in stock. Their delivery time may be longer than usual or they may be unavailable.
- The Δ mark found on some component parts indicates the importance of the safety factor of the part. Therefore, when replacing, be sure to use parts of identical designation.
- When ordering resistors, first convert resistance values into code form as shown in the following examples.

Ex.1 When there are 2 effective digits (any digit apart from 0), such as 560 ohm and 47k ohm (tolerance is shown by J = 5%, and K = 10%).

560Ω	56 × 10 ¹	561	RD1/4PS	5	6	1	J
47kΩ	47 × 10 ³	473	RD1/4PS	4	7	3	J
0.5Ω	0R5		RD2H	0	R	5	K
1Ω	010		RD1P	0	1	0	K

Ex.2 When there are 3 effective digits (such as in high precision metal film resistors).

5.62kΩ	562 × 10 ¹	5621	RD1/4SR	5	6	2	1	F
--------	-----------------------	------	-------	---------	---	---	---	---	---

Mark	Symbol & Description	Part No.	Mark	Symbol & Description	Part No.
DAC ASSEMBLY (AWK1385)			C810	ELECTR.CAPACITOR	CEAS010M50
SEMICONDUCTORS			C811	AUDIO FILM CAPACITOR	CPTXA224J50
IC801	LOGIC IC	TC74HCU04AP	C812	ELECTR.CAPACITOR	CEAS470M10
IC802	DIGITAL I.F. IC	PD0037	C813	CERAMIC CAPACITOR(0.01μF)	ACG1021
IC803		PD0060	C814	CERAMIC CAPACITOR	CCDCH220J50
IC804	LOGIC IC	TC74HC32AP	C815	ELECTR.CAPACITOR	CEAS101M10
IC805		SAA7350GP	C816	CERAMIC CAPACITOR(0.022μF)	ACG1022
IC806,IC807	IC	NJM072D-E	C818	ELECTR.CAPACITOR	CEAS101M10
IC808		RC4558DXP	C819	MICA CAPACITOR	CMA220J500
Q801,Q802	TRANSISTOR	RN2203	C820	ELECTR.CAPACITOR	CEAS470M10
Q804,Q805	TRANSISTOR	2SC2458	C821,C822	CERAMIC CAPACITOR	CKDYX473M16
Q806,Q807	TRANSISTOR	2SC2878	C823	CERAMIC CAPACITOR(0.01μF)	ACG1021
Q808,Q809	TRANSISTOR	RN1203	C824	ELECTR.CAPACITOR	CEAS010M50
Q810	TRANSISTOR	RN2203	C825	ELECTR.CAPACITOR	CEAS101M10
Q811	TRANSISTOR	RN2201	C826	CERAMIC CAPACITOR(0.01μF)	ACG1021
Q812	TRANSISTOR	RN2203	C827	CERAMIC CAPACITOR	CKDYX473M16
D801-D810	DIODE	HSS104-02	C828	ELECTR.CAPACITOR	CEAS470M10
D811	ZENER DIODE	RD6.2ESB	C829	CERAMIC CAPACITOR	CKDYX473M16
COIL			C830	ELECTR.CAPACITOR	CEAS470M10
L801	AXIAL INDUCTOR	LAU330K	C831,C832	CERAMIC CAPACITOR(470p)	ACG1019
L803		ATX1008	C833,C834	CERAMIC CAPACITOR	CCDSL390J50
L804	FERRITE BEAD	ATX1008	C835	CERAMIC CAPACITOR(470p)	ACG1019
L807,L808	AXIAL INDUCTOR	LAU010M	C836	CERAMIC CAPACITOR	CKDYB471K50
L809	FERRITE BEAD	ATX1008	C837,C838	CERAMIC CAPACITOR	CCDSL390J50
L810-L813	AXIAL INDUCTOR	LAU010M	C839,C840	CERAMIC CAPACITOR	CKDYX473M16
L814	FERRITE BEAD	ATX1008	C841,C842	ELECTROLYTIC CAPACIT	CEAS470M10
L817	AXIAL INDUCTOR	LAU010M	C843	CERAMIC CAPACITOR	CKDYX473M16
L818	FERRITE BEAD	ATX1008	C844,C845	CERAMIC CAPACITOR	CKDYB222K50
L819,L820	AXIAL INDUCTOR	LAU010M	C847	ELECTR.CAPACITOR	CEAS101M10
L821,L822	AXIAL INDUCTOR	LAU220K	C848	CERAMIC CAPACITOR	CKDYX473M16
L823-L826	AXIAL INDUCTOR	LAU010M	C849-C852	ELECTROLYTIC CAPACIT	CEAS470M10
L827	FERRITE BEAD	ATX1008	C853,C854	CERAMIC CAPACITOR	CKDYX473M16
CAPACITORS			C855-C858	CERAMIC CAPACITOR(100p)	ACG1017
C805	CERAMIC CAPACITOR	CKDYX473M16	C859,C860	MYLOR FILM CAPACITOR	CQMA102J50
C806	CERAMIC CAPACITOR(0.01μF)	ACG1021	C861,C862	PL.STYRENE CAPACITOR	CQSA101J50
C807	ELECTR.CAPACITOR	CEAS010M50	C863,C864	ELECTROLYTIC CAPACIT	CEYA2R2M50
C808	CERAMIC CAPACITOR(0.01μF)	ACG1021	C865,C866	MYLOR FILM CAPACITOR	CQMA683J50
C809	ELECTR.CAPACITOR	CEAS101M10	C867,C868	CERAMIC CAPACITOR(330p)	ACG1018
			C869,C870	ELECTROLYTIC CAPACIT	CEYA2R2M50
			C871-C876	ELECTR.CAPACITOR	CEAS470M10

Mark Symbol & Description **Part No.**

RESISTORS

R870-R873 CARBON FILM RESISTOR RD1/4PM390J
Other resistors RD1/8PM□□□J

OTHERS

DIGITAL JACK 1-P AKB1073
PHOTO SENSOR MODULE AKX1015
CN1 CONNECTOR(11P) KPE11
CN5 CONNECTOR(8P) KPE8
T801 OSC TRANSFORMER ATX1003

MIC ASSEMBLY

SEMICONDUCTORS

IC601 RC4558DXP
Q601,Q602 TRANSISTOR 2SC2458
D601,D602 DIODE HSS104-02

CAPACITORS

C601 ELECTROLYTIC CAPACIT CEJA220M16
C602 CERAMIC CAPACITOR(470p) ACG1019
C603 ELECTROLYTIC CAPACIT CEJA3R3M50
C604 CERAMIC CAPACITOR(100p) ACG1017
C605 AUDIO FILM CAPACITOR CFTXA474J50

C606 CERAMIC CAPACITOR CKCYB681K50
C607 ELECTROLYTIC CAPACIT CEJA100M25
C608 ELECTR.CAPACITOR CEJA010M50
C609,C610 ELECTR.CAPACITOR CEAS470M10
C611 CERAMIC CAPACITOR CKCYF103Z50

C612,C613 ELECTROLYTIC CAPACIT CEJA100M25

RESISTORS

R614,R615 CARBON FILM RESISTOR RD1/4PM390J
VR601 VARIABLE(100K-X1) ACS1026
VR602 VARIABLE(10K-X1) ACS1025
Other resistors RD1/8PM□□□J

OTHERS

JACK(MIC) AKN1017

HEAD PHONE ASSEMBLY

CAPACITORS

C451 CERAMIC CAPACITOR CKDYX104M25

RESISTORS

R453-R456 METAL OXIDE RESISTOR RS2LMF331J

OTHERS

JACK(HEAD PHONE) AKN1010

SUB TRANS ASSEMBLY

SEMICONDUCTORS

D191,D192 ZENER DIODE RD6.2ESB3

CAPACITORS

C191,C192 CKA (0.01/AC400V) ACG1003

OTHERS

AC SOCKET 1-P AKP1034
SOCKET 8-P AKP1045
RY191 RELAY ASR1024
T191 POWER TRANSFORMER ATT1115

Mark Symbol & Description **Part No.**

POWER VR ASSEMBLY

SEMICONDUCTORS

IC651 RC4558DXP

CAPACITORS

C651,C652 ELECTR.CAPACITOR CEAS100M25
C653 ELECTR.CAPACITOR CEAS470M10
C654 ELECTROLYTIC CAPACIT CEYA470M25
C655 CERAMIC CAPACITOR CKCYX103M25
C656 ELECTROLYTIC CAPACIT CEYA470M25

C657,C658 CERAMIC CAPACITOR CCCSL390J50
C661,C662 ELECTR.CAPACITOR CEAS100M50

RESISTORS

R659-R661 CARBON FILM RESISTOR RD1/4PM390J
VR651 VARIABLE RESISTOR ACX1027
Other resistors RD1/8PM□□□J

OTHERS

CN2 CONNECTOR(15P) KPE15

● DISPLAY ASSEMBLY (AWZ3362)

SEMICONDUCTORS

IC701 PD5160A
Q701-Q704 TRANSISTOR DTA124ES
Q705,Q706 TRANSISTOR DTA143ES
Q707-Q711 TRANSISTOR DTA124ES
Q712,Q713 TRANSISTOR 2SC2458

Q716 TRANSISTOR DTC124ES
Q717,Q718 TRANSISTOR 2SC2458
D701,D702 DIODE HSS104-02
D703 LED(RED) AEL1099
D704-D706 DIODE HSS104-02

D707,D708 LED(RED) AEL1099
D709 LED AEL1100
D710,D712,D714,D715 LED(RED) AEL1099
D717,D718 LED(RED,AMBER) AEL1101
D719-D721 DIODE HSS104-02

D722 LED(RED) AEL1099
D723,D724,D730,D731 DIODE HSS104-02

SWITCHES

S701-S714 SWITCH ASG1029

COIL

L701 AXIAL INDUCTOR LAU101K

CAPACITORS

C701 CERAMIC CAPACITOR CKCYX473M25
C702 ELECTR.CAPACITOR CEAS221M10
C703,C704 CERAMIC CAPACITOR CKCYX103M25
C705 CERAMIC CAPACITOR CKCYB102K50
C706 ELECTR.CAPACITOR CEAS010M50

C707 CEA (47000/5.5V) ACH1070
C708 ELECTR.CAPACITOR CEAS4R7M50
C709,C710 CERAMIC CAPACITOR(0.01μF) ACG1021
C711 CERAMIC CAPACITOR CKCYX473M25

Mark	Symbol & Description	Part No.
RESISTORS		
R742	RESISTOR ARRAY 100K	RA5T104J
R744	RESISTOR ARRAY(100K)	RA6T104J
R761	RESISTOR ARRAY (10K)	RA4T104J
	Other resistors	RD1/8PM□□□J

OTHERS		
X701	CERAMIC RESONATOR SOCKET(10P)	ASS1025
	REMOTE RECEIVER UNIT	AKP1044
		AXX1010

RELAY ASSEMBLY

SEMICONDUCTORS		
Q451	TRANSISTOR	DTC124ES
Q452,Q453	TRANSISTOR	2SD438
Q454	TRANSISTOR	DTC124ES
Q455,Q456	TRANSISTOR	2SD438
D451-D460	ZENER DIODE	RD12ESB3

COILS		
L451,L452	COIL	ATH1004

CAPACITORS		
C461-C464	MYLOR FILM CAPACITOR	CQMA104J50

RESISTORS		
R461-R464	CARBON FILM RESISTOR	RD1/4PMFL100J
R474-476	METAL OXIDE RESISTOR	RS2LMF102J
	Other resistors	RD1/8PM□□□J

OTHERS		
CN451	CONNECTOR(7P)	KPC7
RY451-RY455	RELAY	ASR-112

SP TERMINAL ASSEMBLY

SWITCHES		
S451	SWITCH	ASH1015

CAPACITORS		
C465	ELECTROLYTIC CAPACIT	CEANP4R7M100

OTHERS		
	PIN JACK(2P)	AKB1039
	SPEAKER TERMINAL 8-P	AKE-111
CN453	JUMPER CONNECTOR	KPC8

POWER ASSEMBLY (AWZ2611)

SEMICONDUCTORS		
IC401	AUDIO IC	STK4211-5P

CAPACITORS		
C401,C402	POLYESTER CAPACITOR	CQMXA512J100
C403	ELECTR.CAPACITOR	CEAS4R7M50
C404	ELECTROLYTIC CAPACIT	CEHAQ4R7M50
C405,C406	CERAMIC CAPACITOR	CCDSL470J50
C407,C408	ELECTROLYTIC CAPACIT	CEYA101M50
C409,C410	CERAMIC CAPACITOR	CKDYB102K50
C411,C412	ELECTR.CAPACITOR	CEAS010M50
C413,C414	ELECTR.CAPACITOR	CEAS220M50
C415,C416	ELECTR.CAPACITOR	CEAS470M50
C417,C418	ELECTR.CAPACITOR	CEAS101M25

Mark	Symbol & Description	Part No.
C423	ELECTR.CAPACITOR	CEAS470M50
C425,C426	MICA CAPACITOR	CMA030D500
C427-C430	ELECTROLYTIC CAPACIT	CEYA220M50

RESISTORS		
R405,R406	CARBON FILM RESISTOR	RDR1/4PM563.
R411-R414	CARBON FILM RESISTOR	RD1/2PM472J
R417,R418	CARBON FILM RESISTOR	RD1/4PMFL22J
R419	CARBON FILM RESISTOR	RD1/2PM102J
R420,R422	CARBON FILM RESISTOR	RD1/4PMFL10J
R421	CARBON FILM RESISTOR	RD1/4PMFL47J
	Other resistors	RD1/8PM□□□J

FUSE ASSEMBLY

CAPACITORS		
C390	MYLOR FILM CAPACITOR	CQMA104K250

AF ASSEMBLY (AWZ3404)

SEMICONDUCTORS		
IC101	REGULATOR IC	UPC78M05H
IC102	REGULATOR IC	NJM78M56FAS
IC103	REGULATOR IC	NJM79M05FA
IC104	REGULATOR IC	UPC78M12H
IC105	MECHANISM DRIVER IC	TA7291S

IC201		RC4558DXP
IC202	LOGIC IC	TC4066BP
IC203		MC14052BCP
IC204	OP-AMP IC	M5218ALF
IC205	E-SW IC	LC4966

IC206		MC14052BCP
IC207		RC4558DXP
IC208	OP-AMP IC	M5218ALF
IC501		MC14052BCP
Q101	TRANSISTOR	2SB560

Q102	TRANSISTOR	2SA970
Q103-Q105	TRANSISTOR	2SC2458
Q106	TRANSISTOR	2SD438
Q107,Q108	TRANSISTOR	DTC124ES
Q501	TRANSISTOR	2SA1048

Q502	TRANSISTOR	2SC2458
Q503,Q551	TRANSISTOR	2SA1048
Q552	TRANSISTOR	2SC2603
Q553	TRANSISTOR	2SA1048
D101	DIODE	RBV602

D102-D107	DIODE	S5566
D108	DIODE	RB152
D109	DIODE	HSS104-02
D110	ZENER DIODE	RD33ES B2
D111	ZENER DIODE	RD6.2ESB

D112,D113	DIODE	HSS104-02
D114	ZENER DIODE	RD3.0ESB1
D115	DIODE	HSS104-02
D116	ZENER DIODE	RD4.7ESB
D117	DIODE	HSS104-02

D158	ZENER DIODE	RD12ES B3
D501	DIODE	HSS104-02

Mark	Symbol & Description	Part No.
COILS		
	L501,L502 AXIAL INDUCTOR	LAU101K
CAPACITORS		
	C101 CKA (0.01/AC250V)	ACG1005
	C102,C103 CERAMIC CAPACITOR	CKDYF103Z50
	C104,C105 ELECTR.CAPACIT(5600/56)	ACH1031
	C106,C107 ELECTR.CAPACITOR	CEAS222M16
	C108 ELECTR.CAPACITOR	CEAS471M50
	C109 ELECTR.CAPACITOR	CEAS332M25
	C110 ELECTR.CAPACITOR	CEHAQ101M50
	C111,C112 ELECTR.CAPACITOR	CEAS101M50
	C113 ELECTROLYTIC CAPACIT	CEHAQ220M50
	C114 ELECTROLYTIC CAPACIT	CEHAQ470M50
	C115 ELECTR.CAPACITOR	CEHAQ101M50
	C116 ELECTROLYTIC CAPACIT	CEHAQ221M10
	C117 ELECTR.CAPACITOR	CEAS100M25
	C118 CERAMIC CAPACITOR	CKCYX103M25
	C119 ELECTR.CAPACITOR	CEAS221M10
	C120 ELECTR.CAPACITOR	CEAS010M50
	C121 CERAMIC CAPACITOR(0.01μF)	ACG1021
	C160 ELECTR.CAPACITOR	CEAS101M50
	C201,C202 CERAMIC CAPACITOR(100p)	ACG1017
	C203,C204 ELECTR.CAPACITOR	CEAS2R2M50
	C205,C206 ELECTR.CAPACITOR	CEAS3R3M50
	C207,C208 CERAMIC CAPACITOR(100p)	ACG1017
	C209,C210 CERAMIC CAPACITOR	CKCYB152K50
	C211,C212 CERAMIC CAPACITOR	CKCYB562K50
	C213,C214 ELECTR.CAPACITOR	CEAS010M50
	C215,C216 ELECTR.CAPACITOR	CEAS470M10
	C217,C218 ELECTR.CAPACITOR	CEAS4R7M50
	C219,C220 ELECTR.CAPACITOR	CEAS100M25
	C221,C222 ELECTROLYTIC CAPACIT	CEYA470M50
	C223,C224 ELECTR.CAPACITOR	CEAS100M25
	C233-C236 ELECTR.CAPACITOR	CEAS100M25
	C237 CERAMIC CAPACITOR	CKDYX104M25
	C238 CERAMIC CAPACITOR	CKDYF473Z50
	C239,C240 ELECTR.CAPACITOR	CEAS2R2M50
	C241-C244 ELECTR.CAPACITOR	CEAS100M25
	C245 ELECTR.CAPACITOR	CEASR22M50
	C247,C248 ELECTROLYTIC CAPACIT	CEYA470M50
	C387 CERAMIC CAPACITOR	CKDYF473Z50
	C502,C503 ELECTR.CAPACITOR	CEAS101M10
	C504 ELECTROLYTIC CAPACIT	CEAS102M6
	C505 CERAMIC CAPACITOR	CCCSL270J50
	C506 ELECTROLYTIC CAPACIT	CEAS102M6
	C507-C509 ELECTR.CAPACITOR	CEAS101M10
RESISTORS		
△	R101,R102 METAL OXIDE RESISTOR	RS2LMFR22J
△	R103 METAL OXIDE RESISTOR	RS2LMF222J
△	R105,R106 CARBON FILM RESISTOR	RD1/4PMF470J
△	R121,R122 METAL OXIDE RESISTOR	RS1LMF8R2J
△	R129 CARBON FILM RESISTOR	RD1/2PMFL2R2J
	R130,R131 CARBON FILM RESISTOR	RD1/2PM472J
	R132-R134 CARBON FILM RESISTOR	RD1/4PM100J
△	R135 CARBON FILM RESISTOR	RD1/4PM100J
△	R136 METAL OXIDE RESISTOR	RS3LMF2R2J
	R217,R218 CARBON FILM RESISTOR	RD1/4PM390J
	Other resistors	RD1/8PM□□□J

Mark	Symbol & Description	Part No.
OTHERS		
	PHONO JACK 4-P	AKB-115
	PIN JACK(1P)	AKB1105
	PIN JACK(9P)	AKB1128
	PLUG(10P)	AKM1037
	JACK	AKN-203
	SOCKET(4P)	AKP1046
	SOCKET(14P)	AKP1048
	SOCKET(15P)	AKP1049
	SOCKET(13P)	AKP1052
	SCREW	PBZ30P080FMC

●STANDBY ASSEMBLY (AWZ3505)

Mark	Symbol & Description	Part No.
SEMICONDUCTORS		
	IC151 REGULATOR IC	NJM78M56FAS
	Q152 TRANSISTOR	2SB560
	Q554 TRANSISTOR	2SD438
	D151-D154 DIODE	S5566
	D156 ZENER DIODE	RD33ESB2
	D157 ZENER DIODE	RD6.2ESB

Mark	Symbol & Description	Part No.
CAPACITORS		
	C151 ELECTROLYTIC CAPACIT	CEHAQ222M16
	C152 ELECTROLYTIC CAPACIT	CEHAQ471M16
	C153,C156 ELECTROLYTIC CAPACIT	CEHAQ221M50
	C157 ELECTROLYTIC CAPACIT	CEHAQ220M50
	C158 ELECTROLYTIC CAPACIT	CEHAQ470M50
	C159 ELECTROLYTIC CAPACIT	CEHAQ221M10

Mark	Symbol & Description	Part No.
RESISTORS		
△	R151,R152 METAL OXIDE RESISTOR	RS3LMF122J
△	R153 METAL OXIDE RESISTOR	RS2LMF222J
△	R157 CARBON FILM RESISTOR	RD1/4PMFL4R7J
	Other resistors	RD1/8PM□□□J

DSP ASSEMBLY (AWK1445)

Mark	Symbol & Description	Part No.
SEMICONDUCTORS		
	IC901-IC903	RC4558DXP
	IC904 AD CONVERTER IC	TD6726N
	IC905	PD0055
	IC906,IC907 MEMORY IC	MB81464-12
	IC908 CONTROL MCU	PDG071A
	Q901 TRANSISTOR	DTA143ES
	D901,D902 DIODE	HSS104-02

Mark	Symbol & Description	Part No.
COILS, FILTERS		
	F901,F902 FILTER	ATF1071
	L901-L903 AXIAL INDUCTOR	LAU330K
	L904 AXIAL INDUCTOR	LAUR22M
	L905,L906 AXIAL INDUCTOR	LAU220K
	L999 AXIAL INDUCTOR	LAU330K

Mark	Symbol & Description	Part No.
CAPACITORS		
	C901,C902 ELECTR.CAPACITOR	CEAS2R2M50
	C903,C904 MYLOR FILM CAPACITOR	CQMA563J50
	C905,C906 ELECTR.CAPACITOR	CEAS220M25
	C907,C908 PL.STYRENE CAPACITOR	CQSA202J50
	C909,C910 CERAMIC CAPACITOR	CCCSL151J50

Mark	Symbol & Description	Part No.
C911,C912	CERAMIC CAPACITOR	CCCSL180J50
C913-C916	CERAMIC CAPACITOR	CKCYX473M25
C917,C918	ELECTROLYTIC CAPACIT	CEANP470M16
C919	CERAMIC CAPACITOR	CCDCH100D50
C920	CERAMIC CAPACITOR	CCDCH330J50
C921	CERAMIC CAPACITOR	CKDYF473Z50
C922	CERAMIC CAPACITOR	CCDCH100D50
C923	CERAMIC CAPACITOR	CKDYF473Z50
C924	ELECTR.CAPACITOR	CEAS470M10
C925	CERAMIC CAPACITOR(0.022 μ F)	ACG1022
C926	ELECTR.CAPACITOR	CEAS470M25
C927	CERAMIC CAPACITOR(0.022 μ F)	ACG1022
C928-C930	ELECTR.CAPACITOR	CEAS470M25
C931	ELECTR.CAPACITOR	CEAS010M50
C932	CERAMIC CAPACITOR(0.022 μ F)	ACG1022
C933	ELECTR.CAPACITOR	CEAS101M16
C934	ELECTR.CAPACITOR	CEAS101M50
C935	CERAMIC CAPACITOR	CKDYF473Z50
C937,C938	CERAMIC CAPACITOR	CCDCH100D50
C939	CERAMIC CAPACITOR(0.022 μ F)	ACG1022
C940	CERAMIC CAPACITOR(0.022 μ F)	ACG1022
C941	CERAMIC CAPACITOR	CKDYF473Z50
C943,C944	ELECTR.CAPACITOR	CEAS101M50
C945	CERAMIC CAPACITOR	CKDYF473Z50
C947,C948	CERAMIC CAPACITOR(0.01 μ F)	ACG1021

RESISTORS

R952,R953	CARBON FILM RESISTOR	RD1/4PM390J
R955	RESISTOR ARRAY (10K)	RA7T103J
VR901	VR	VRTB6VS102
VR902	VR	VRTB6VS102
	Other resistors	RD1/8PM□□□J

OTHERS

CN6	CONNECTOR(15P)	KPE15
CN7	CONNECTOR(12P)	KPE12
X901	CRYSTAL RESONATOR	ASS1036
X902	CRYSTAL RESONATOR	ASS1035
X903	CRYSTAL RESONATOR	ASS1015

4. SCHEMATIC DIAGRAMS AND P.C.BOARD CONNECTION DIAGRAMS

4.1 OVER ALL SCHEMATIC DIAGRAM

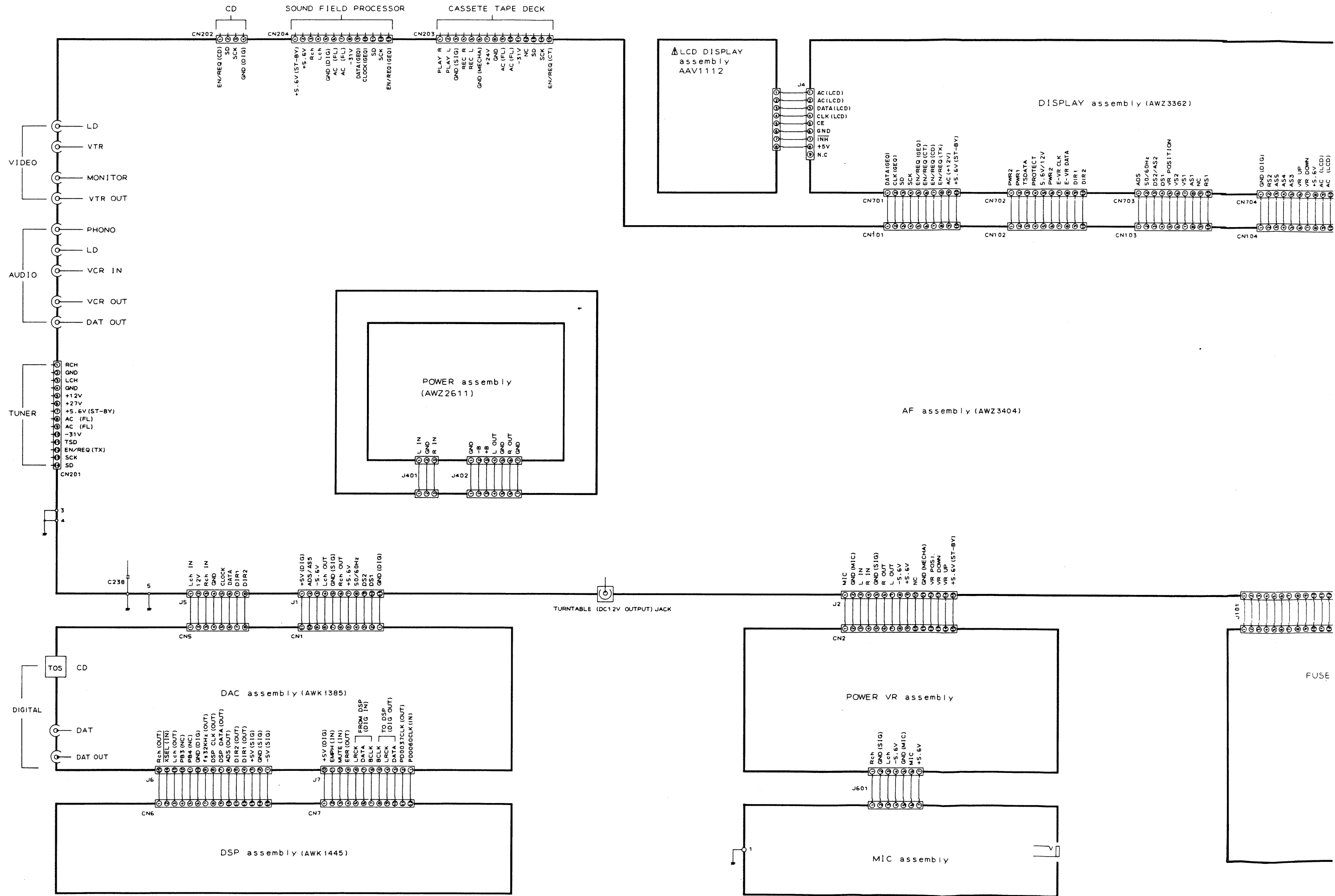

1.RESISTORS :

Indicated in Ω , 1/8, 1/4W,, $\pm 5\%$ tolerance unless otherwise noted
 k; k Ω , M; M Ω , (F); $\pm 1\%$, (G); $\pm 2\%$, (K); $\pm 10\%$, (M);
 $\pm 20\%$ tolerance.

2.CAPACITORS :

Indicated in capacity (μ F)/voltage(V) unless otherwise noted p ;
 pF. Indication without voltage is 50V except electrolytic capacitor.

3.VOLTAGE, CURRENT :

$\sqrt{\quad}$; Signal voltage at 80 W + 80 W, 8 Ω output(1kHz).

\square ; DC voltage (V) at no input signal.

\square Value in () is DC voltage at rated power.

\leftarrow mA ; DC current at no input signal.

4.OTHERS :

\rightarrow ; Signal route.

\odot ; Adjusting point

The Δ mark found on some component parts indicates the importance of the safety factor of the part. Therefore, when replacing, be sure to use parts of identical designation.

* marked capacitors and resistors have parts numbers.

This is the basic schematic diagram, but the actual circuit may vary due to improvements in design.

5.SWITCHES :

DISPLAY ASSEMBLY

- | | |
|-----------------|------------------------|
| S701 : POWER | S709 : LD |
| S702 : LSS SET | S710 : VCR |
| S703 : LSS MODE | S711 : VIDEO SIGNAL |
| S704 : PHONO | SELECTOR |
| S705 : TUNER | S712 : DIRECT MODE |
| S706 : TAPE | S713 : MUTING |
| S707 : DAT | S714 : SPEAKERS A/B OR |
| S708 : CD | A+B |

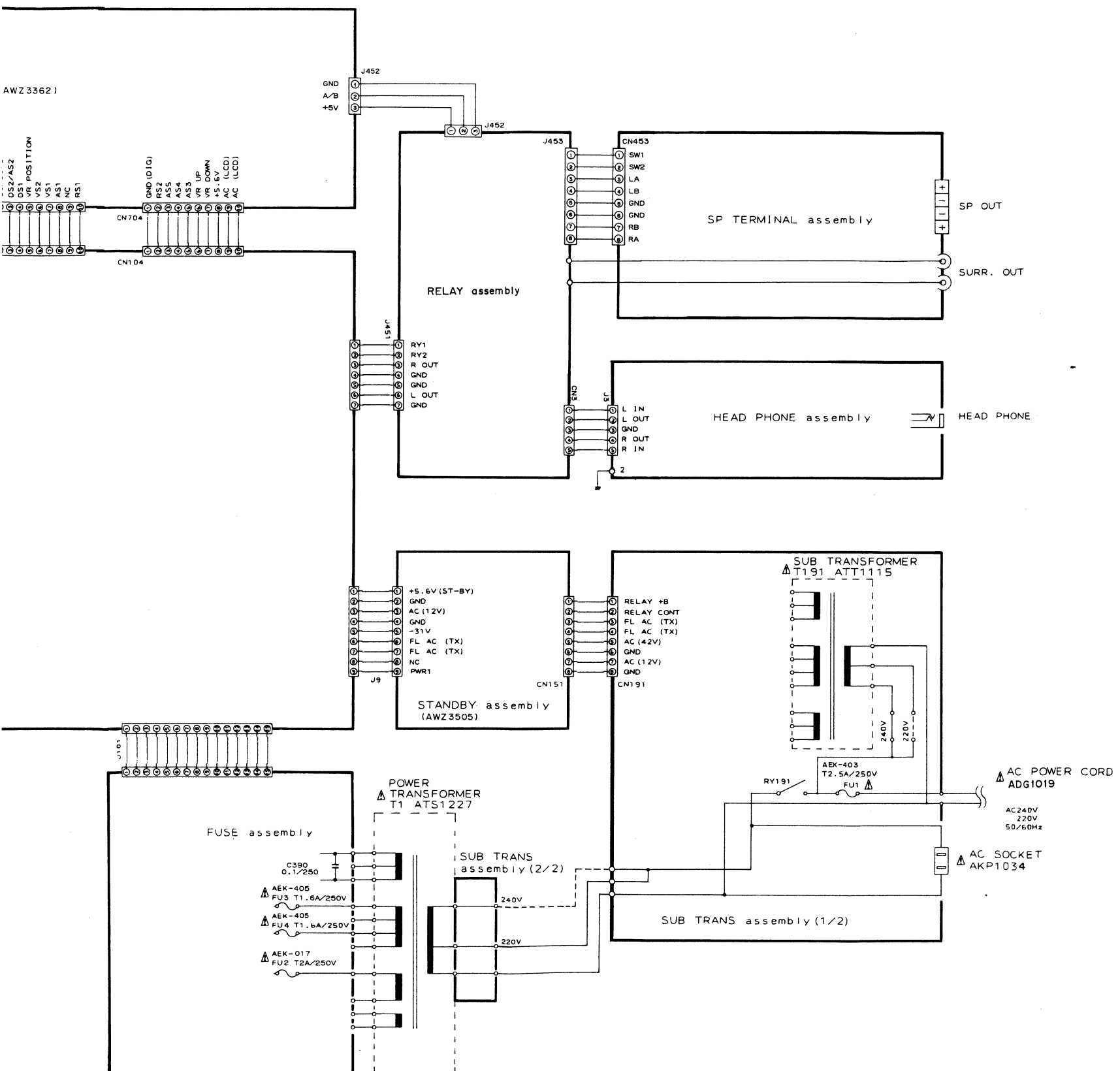

1 2 3 4 5 6

AF assembly (AWZ3404)

To DAC assembly CN5
(To page 35)

To DAC assembly CN1
(To page 35)

POWER VR assembly

TURNTABLE
DC 12V

PHONO

DAT
OUT

VCR
OUT

VCR
IN

LD
IN

MONITOR
OUT

TUNER

CD

CASSETTE
TAPE
DECK

SOUND
FIELD
PROCESSOR

ANP1330-F

A

B

C

D

IC201
IC202
IC206

IC205
IC204

IC203
IC207
IC208

IC101
IC105

Q501
Q503
Q502
Q102
Q106
Q104
Q105

Q108
Q107

Q101
Q552

Q551
Q553

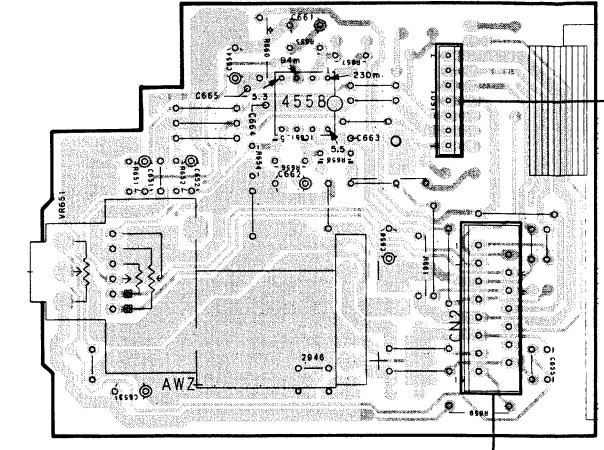

To DISPLAY assembly CN704
(To page 30)

POWER assembly (AWZ2611)

To DISPLAY assembly CN703
(To page 30)

To DISPLAY assembly CN702
(To page 29)

FUSE assembly

To DISPLAY assembly CN701
(To page 29)

STANDBY assembly (AWZ3505)

1 2 3 4 5 6

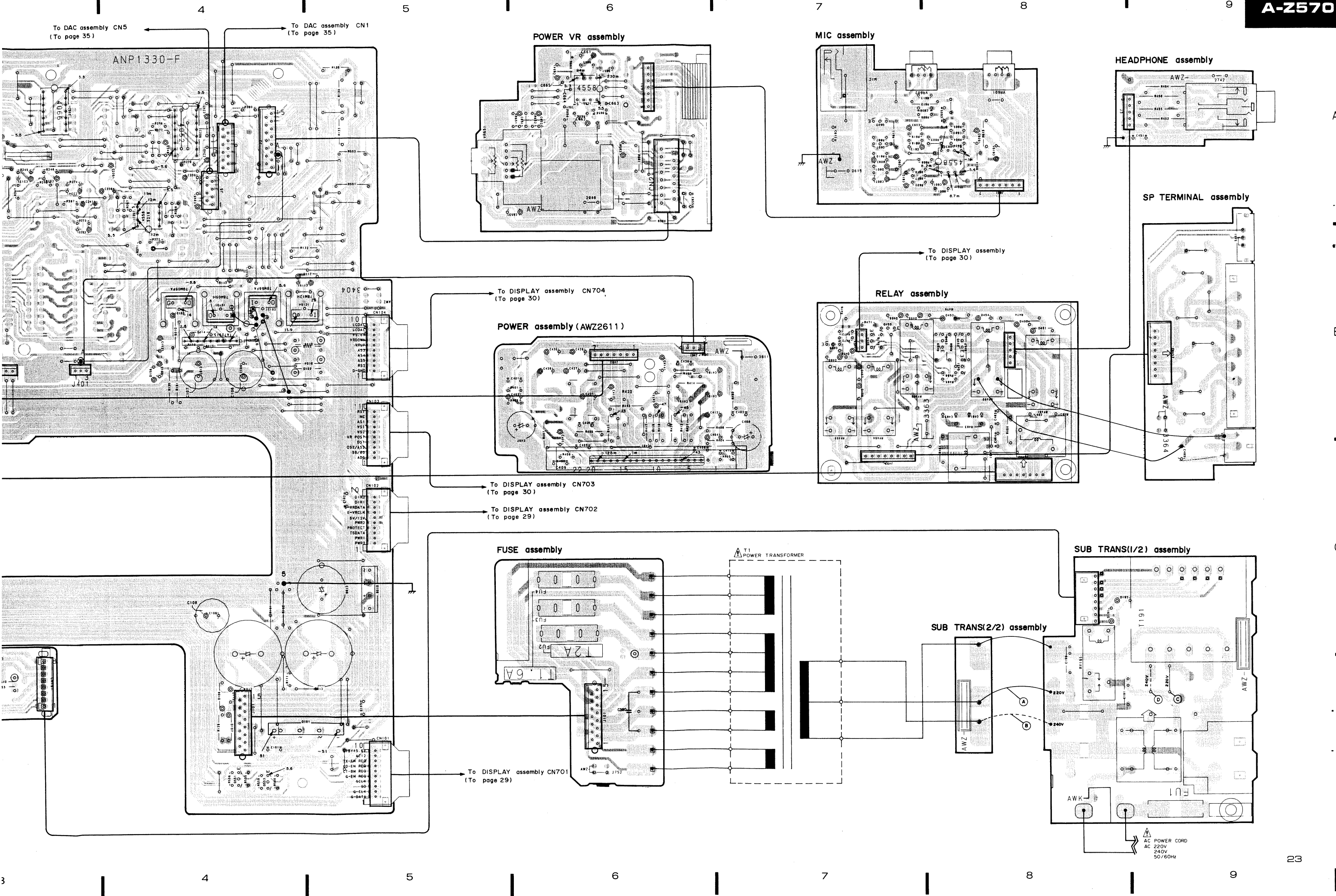

A

B

C

D

4.2 AF(AWZ3404), STANDBY(AWZ3505), SP TERMINAL, FUSE, POWER(AWZ2611), MIC, POWER VR, RELAY, SUB TRANS and HEAD PHONE assemblies

A
B
C
D

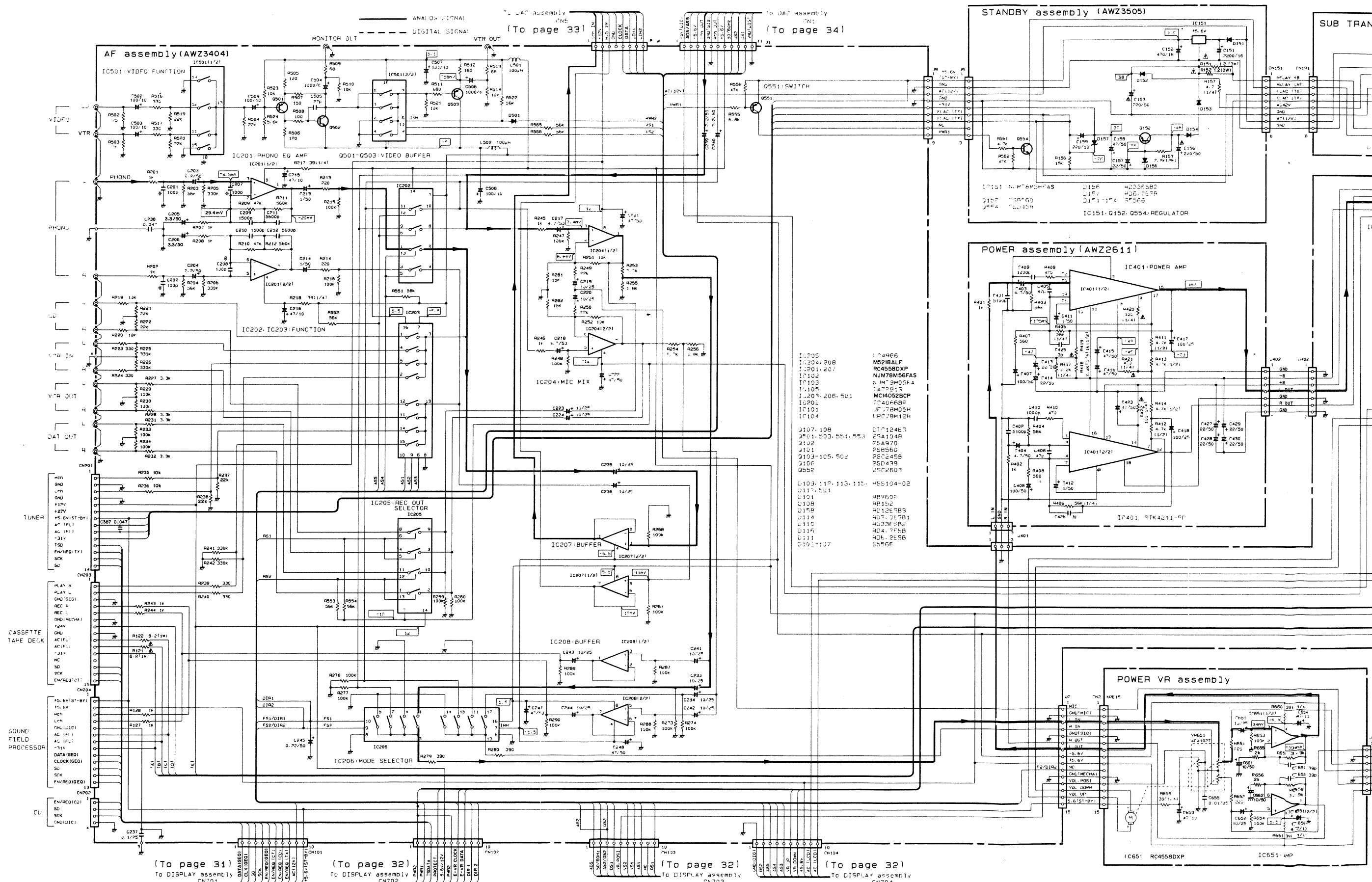

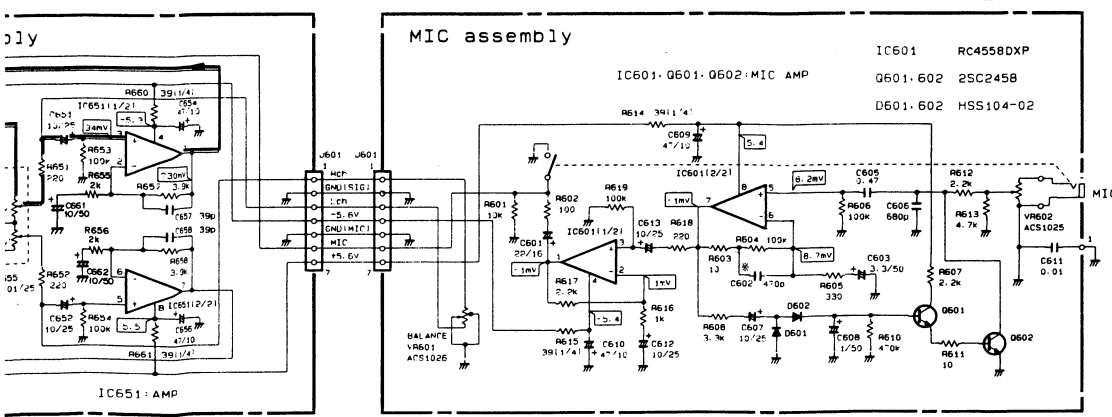
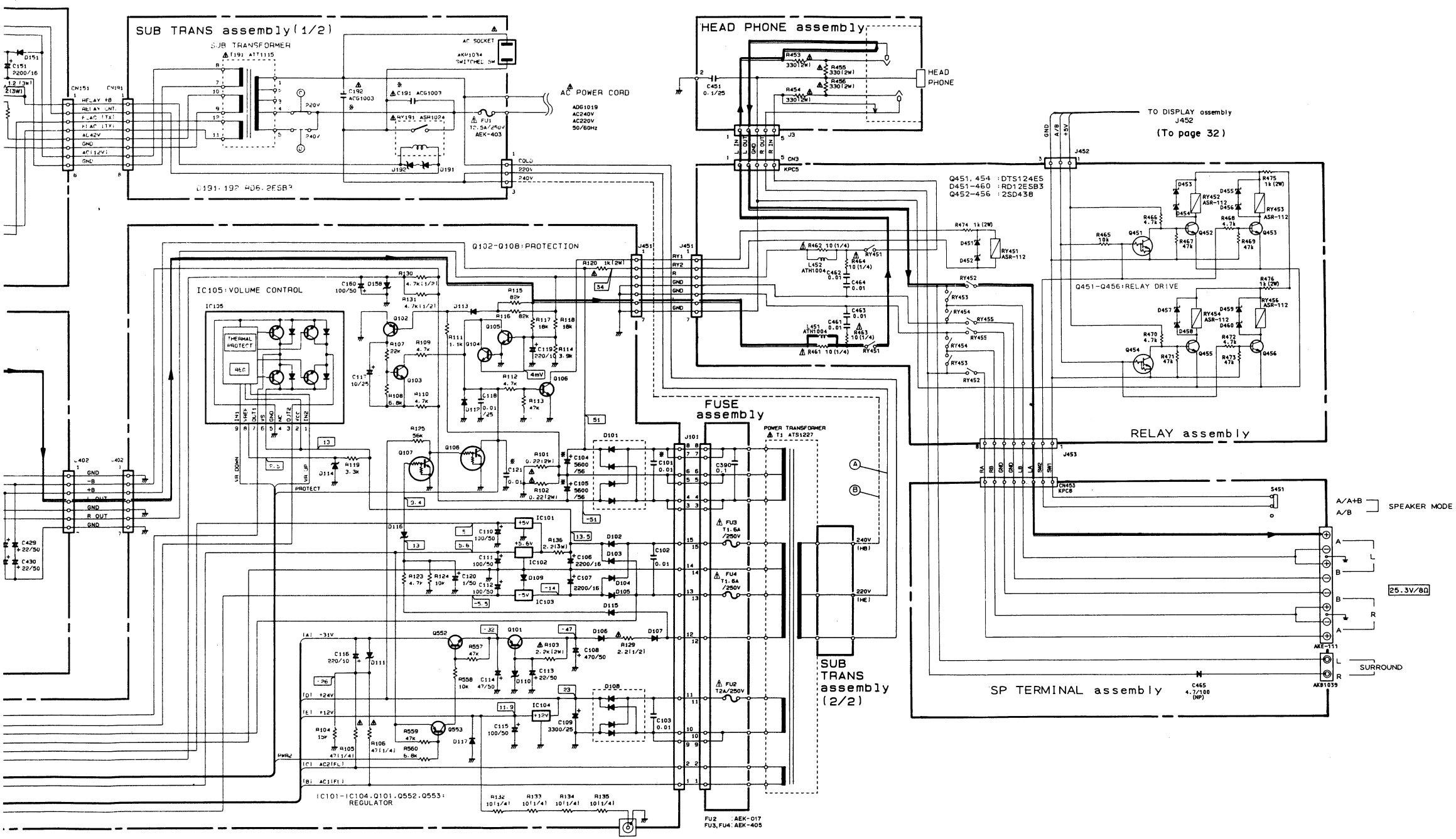

Line Voltage Selection (HE AND HEWZIW TYPES)

Line voltage can be changed with the following steps.

1. Disconnect the AC power cord.
2. Remove the top cover.
3. Change the position of the connection wires to SUB TRANS ASSEMBLY (1/2) from SUB TRANS ASSEMBLY (2/2) as follows.

Voltage	Connection Wire (A)	Connection Wire (B)
220V	○	×
240V	×	○

- : Be needed
- × : Be needless

4. Change the position of the jumper wires (C) and (D) as follows. (SUB TRANS ASSEMBLY(1/2)).

Voltage	Jumper Wire (C)	Jumper Wire (D)
220V	○	×
240V	×	○

- : Be needed
- × : Be needless

5. Stick the line voltage label on the rear panel.

Parts No.	Description
AXX-193	220V label
AXX-192	240V label

A

B

C

D

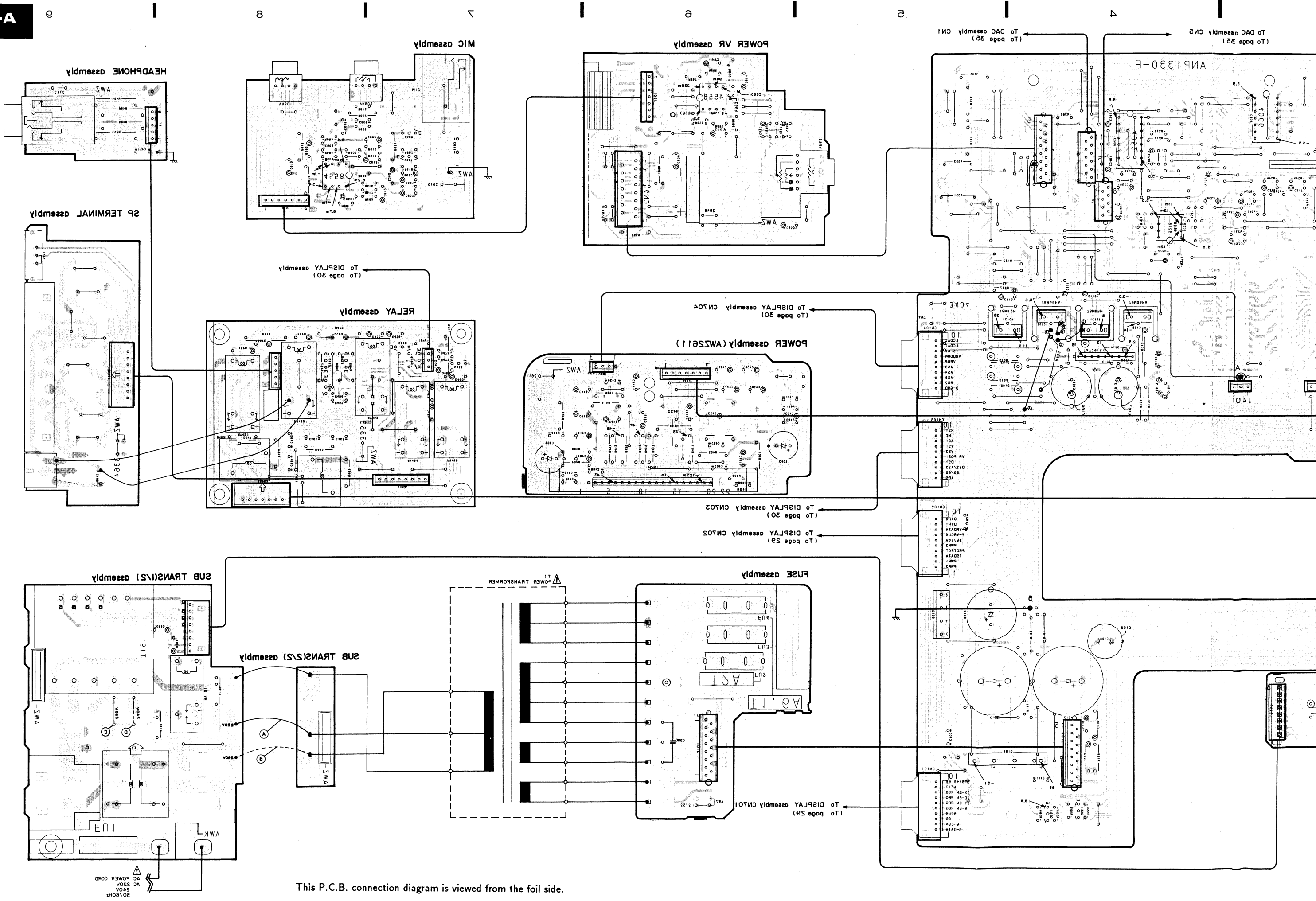

This P.C.B. connection diagram is viewed from the foil side.

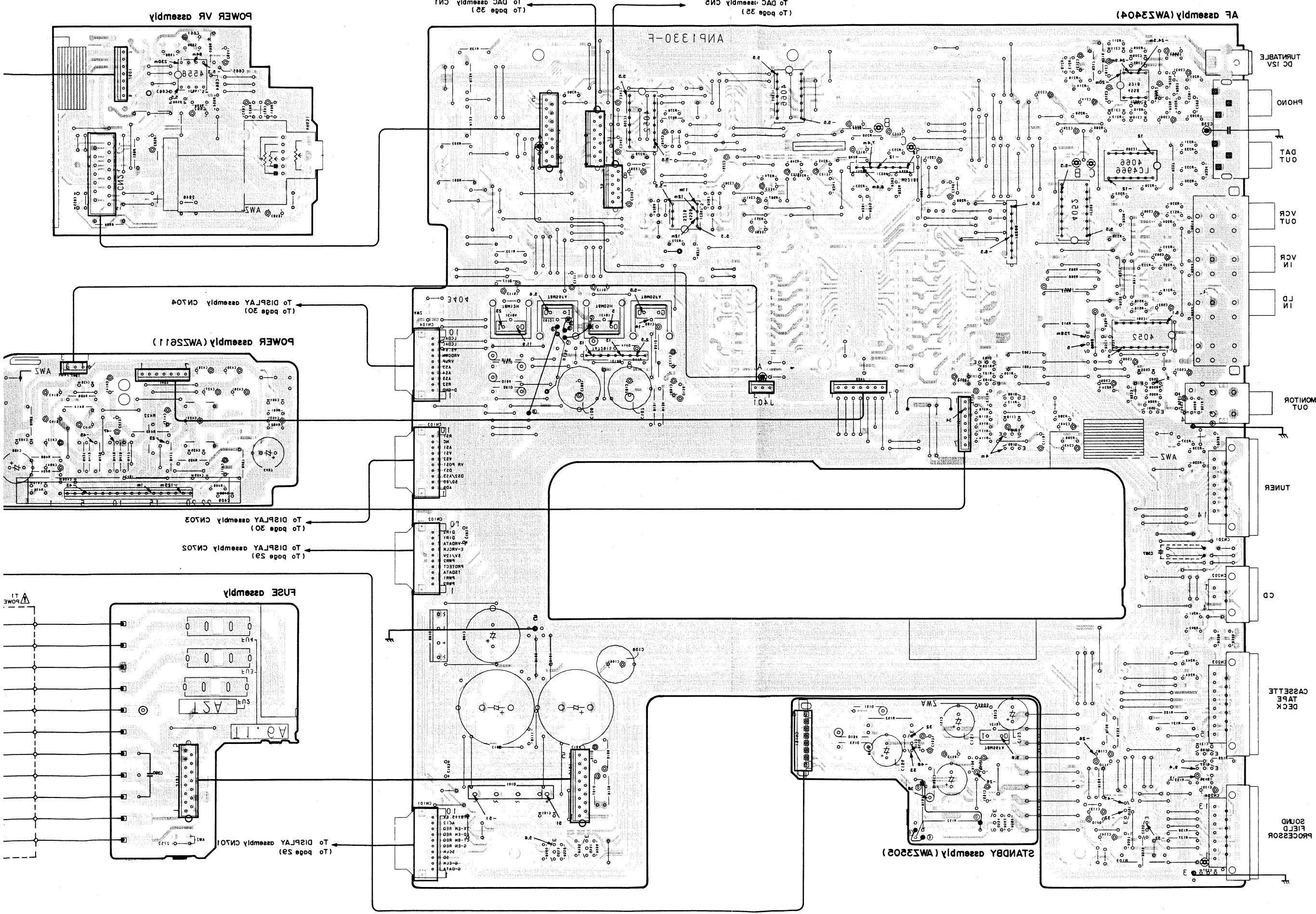

IC501	IC505	IC506	IC502	IC504	IC503	IC508	IC501	IC101	IC102	IC201	IC202	IC203	IC205	IC206	IC207	IC208	IC209	IC210	IC211	IC212	IC213	IC214	IC215	IC216	IC217	IC218	IC219	IC220	IC221	IC222	IC223	IC224	IC225	IC226	IC227	IC228	IC229	IC230	IC231	IC232	IC233	IC234	IC235	IC236	IC237	IC238	IC239	IC240	IC241	IC242	IC243	IC244	IC245	IC246	IC247	IC248	IC249	IC250	IC251	IC252	IC253	IC254	IC255	IC256	IC257	IC258	IC259	IC260	IC261	IC262	IC263	IC264	IC265	IC266	IC267	IC268	IC269	IC270	IC271	IC272	IC273	IC274	IC275	IC276	IC277	IC278	IC279	IC280	IC281	IC282	IC283	IC284	IC285	IC286	IC287	IC288	IC289	IC290	IC291	IC292	IC293	IC294	IC295	IC296	IC297	IC298	IC299	IC300
-------	-------	-------	-------	-------	-------	-------	-------	-------	-------	-------	-------	-------	-------	-------	-------	-------	-------	-------	-------	-------	-------	-------	-------	-------	-------	-------	-------	-------	-------	-------	-------	-------	-------	-------	-------	-------	-------	-------	-------	-------	-------	-------	-------	-------	-------	-------	-------	-------	-------	-------	-------	-------	-------	-------	-------	-------	-------	-------	-------	-------	-------	-------	-------	-------	-------	-------	-------	-------	-------	-------	-------	-------	-------	-------	-------	-------	-------	-------	-------	-------	-------	-------	-------	-------	-------	-------	-------	-------	-------	-------	-------	-------	-------	-------	-------	-------	-------	-------	-------	-------	-------	-------	-------	-------	-------	-------	-------	-------

il side.



4.3 DISPLAY(AWZ3362) assembly

NOTE

1. This P.C.B connection diagram is viewed from the parts mounted side.
2. The parts which have been mounted on the board can be replaced with those shown with the corresponding wiring symbols listed in the following Table.

P.C.B. pattern diagram indication	Corresponding part symbol	Part Name
		Transistor
		Radiator type transistor
		Diode
		Resistor
		Capacitor (Polarity)
		Capacitor (Non-polarity)

Others

P.C.B. pattern diagram indication	Part Name
IC	IC
S	Switch
RY	Relay
L	Coil
F	Filter
VR	Variable resistor or Semi-fixed resistor

3. The capacitor terminal marked with ⊖ (double circles) shows negative terminal.
4. The diode terminal marked with ⊖ (double circles) shows cathode side.
5. The transistor terminal to which E is affixed shows the emitter.

LCD DISPLAY assembly

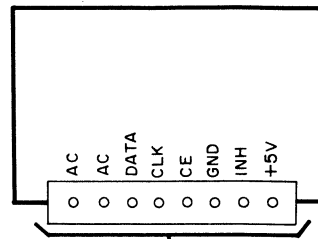

DISPLAY assembly (AWZ3362)

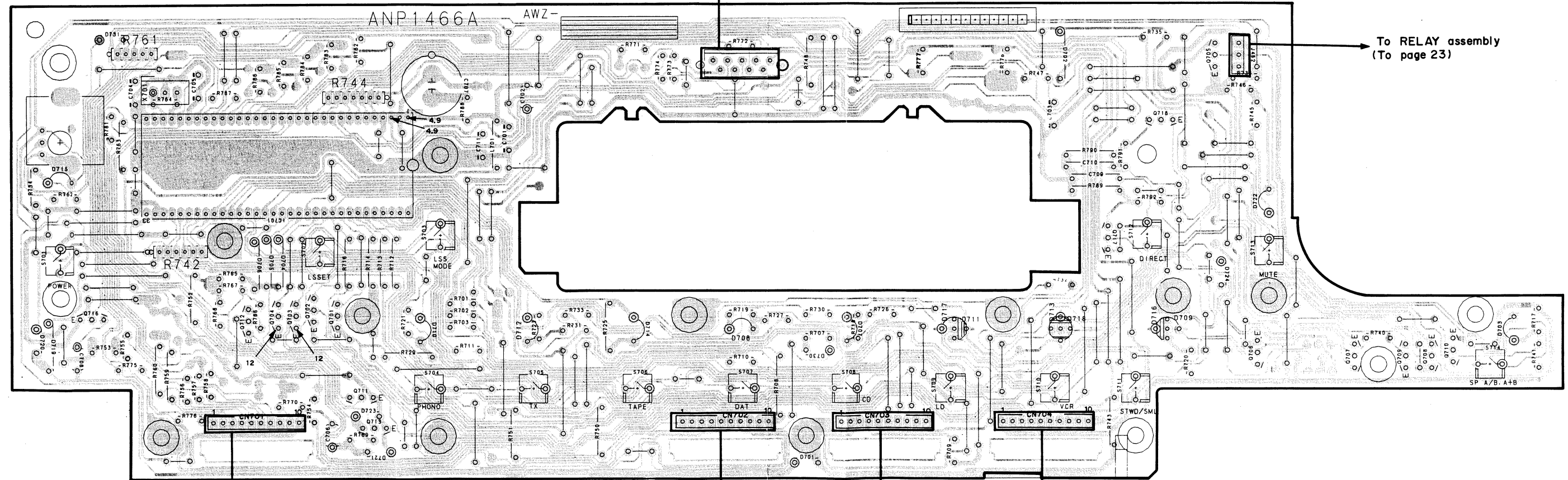

To RELAY assembly
(To page 23)

Q716
IC701 Q711
Q712 Q703 Q701 Q713
Q704 Q702
To AF assembly CN101
(To page 22)

To AF assembly CN102
(To page 22)

To AF assembly CN103
(To page 22)

To AF assembly CN104
(To page 22)

Q717 Q718 Q705 Q706 Q714 Q707 Q709 Q708 Q710
Q715

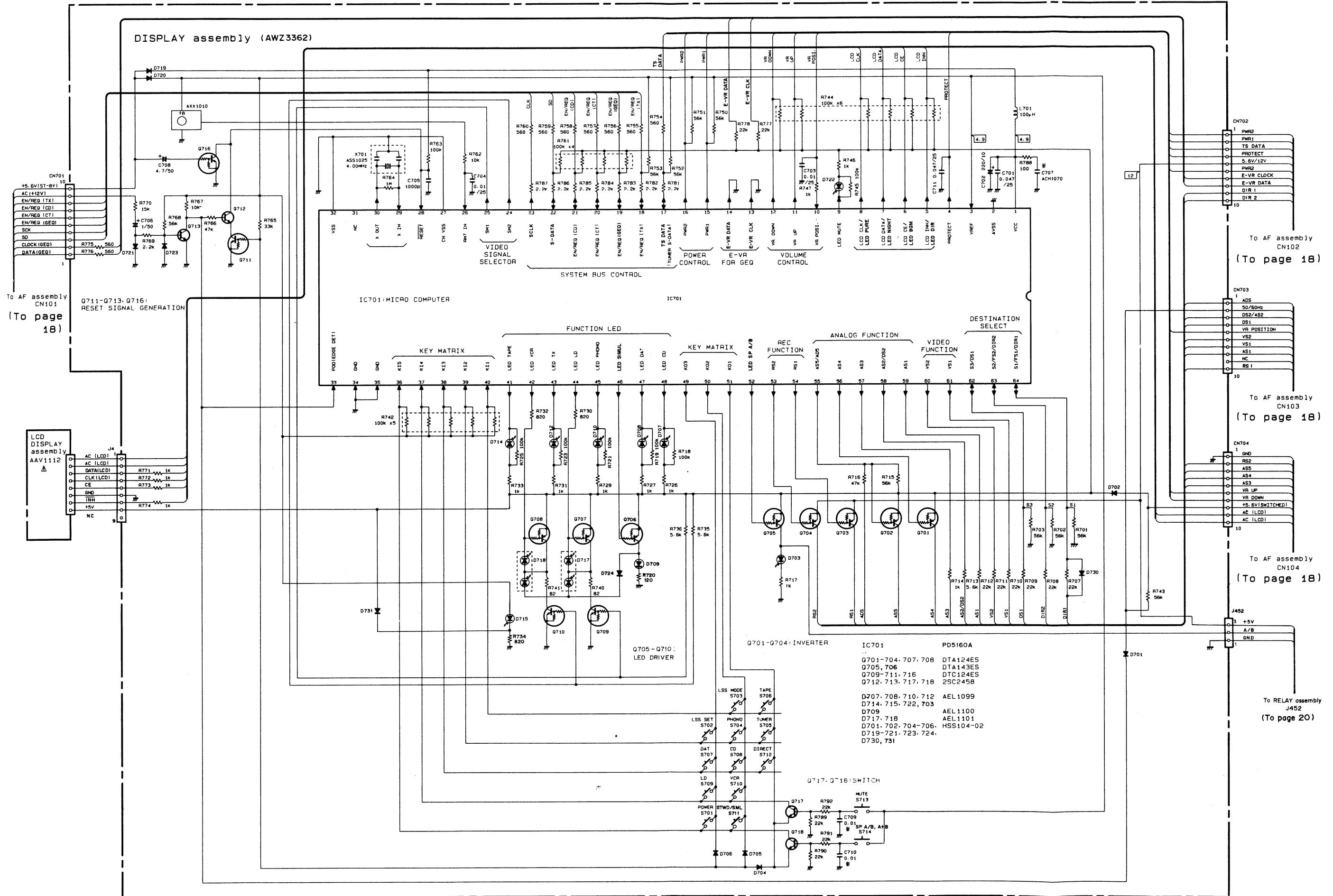

4.4 DAC(AWK1385) assembly

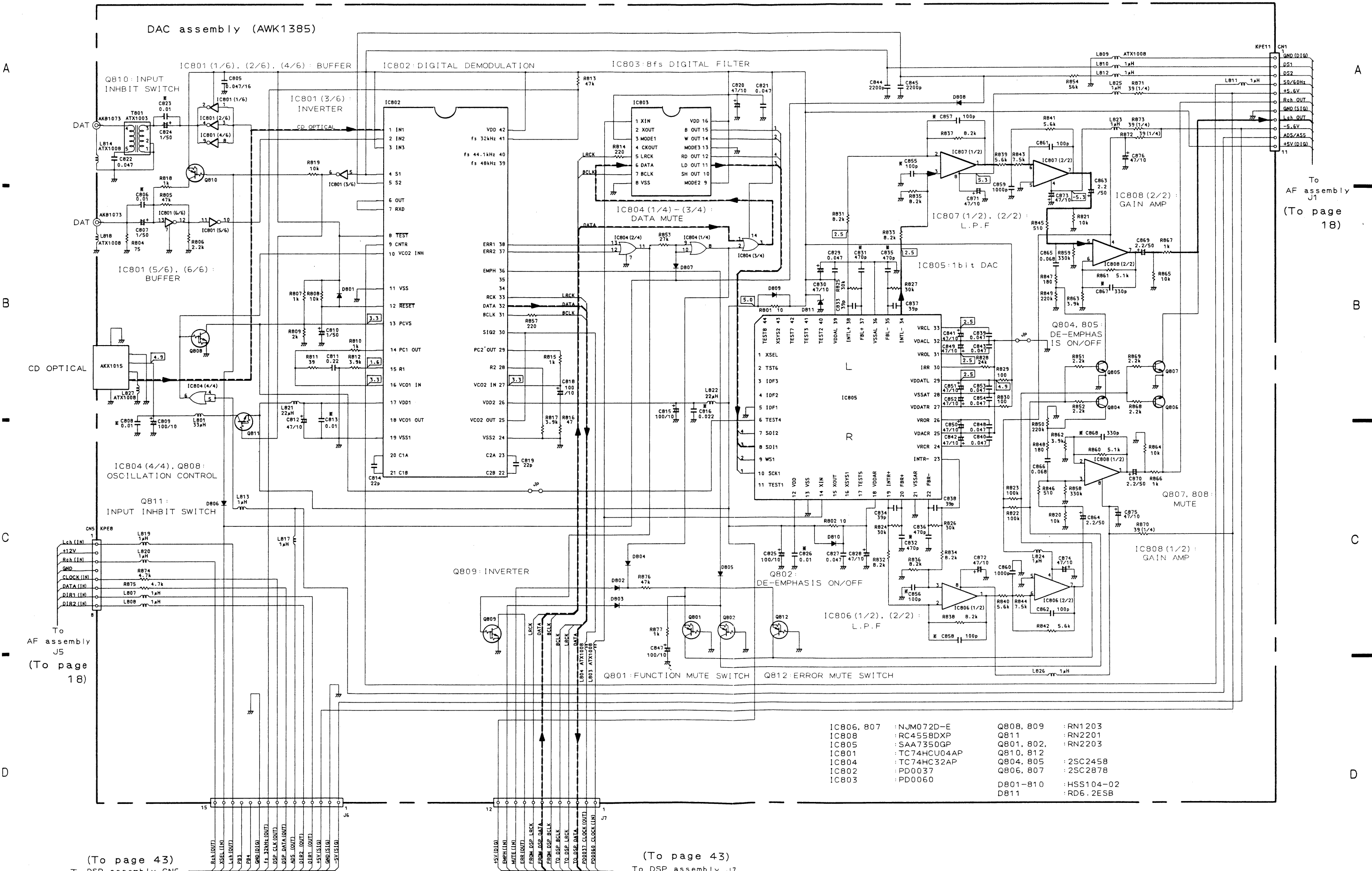

IC806, 807	: NJM072D-E	Q808, 809	: RN1203
IC808	: RC4558DXP	Q811	: RN2201
IC805	: SAA7350GP	Q801, 802,	: RN2203
IC801	: TC74HC04AP	Q810, 812	
IC804	: TC74HC32AP	Q804, 805	: 2SC2458
IC802	: PD0037	Q806, 807	: 2SC2878
IC803	: PD0060	D801-810	: HSS104-02
		D811	: RD6.2ESB

(To page 43)
To DSP assembly CN6

(To page 43)
To DSP assembly J7

To AF assembly J1
(To page 18)

1

2

3

4

5

6

DAC assembly (AWK1385)

To AF assembly J5
(To page 22)

To AF assembly J1
(To page 22)

To DSP assembly CN6
(To page 42)

To DSP assembly CN7
(To page 41)

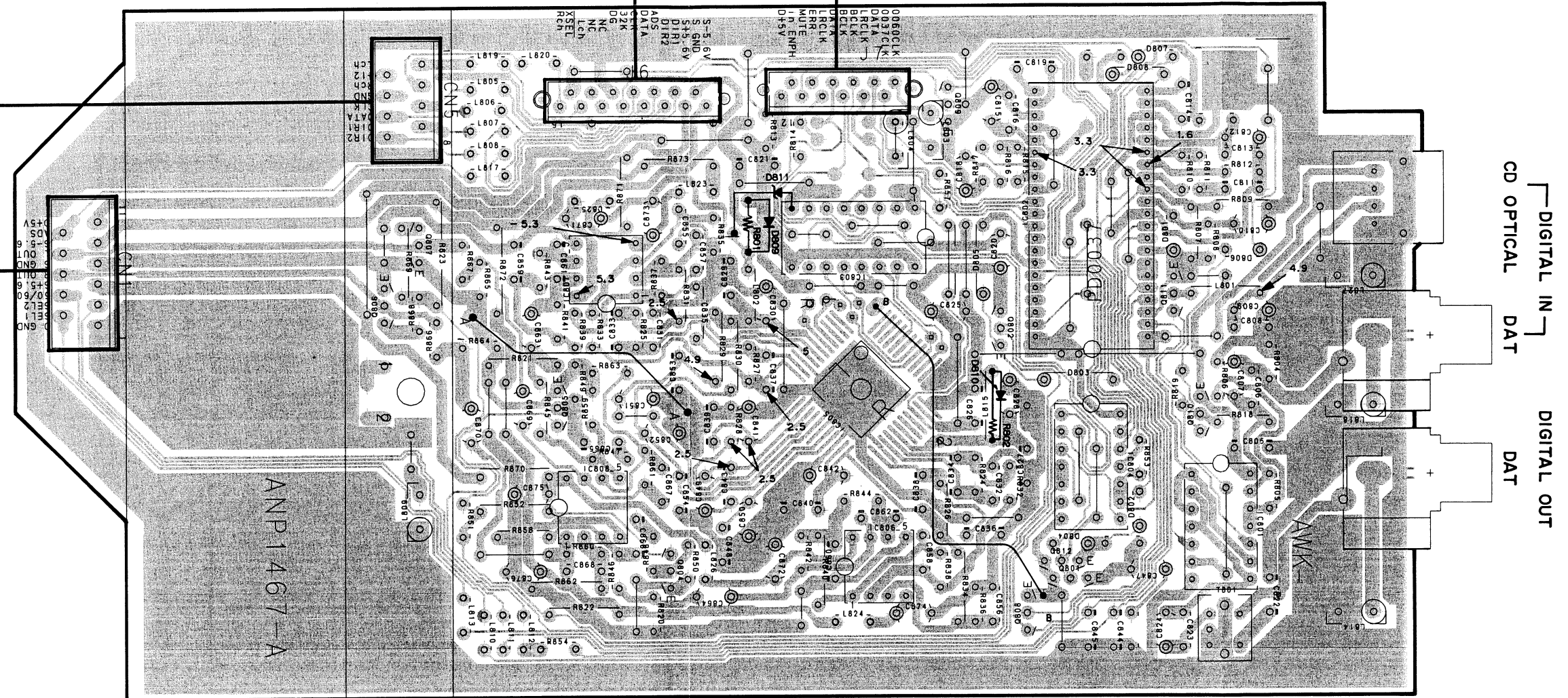

- Q806
- Q807
- Q805
- IC807
- IC803
- Q809
- Q802
- IC802
- Q811
- Q810
- IC808
- Q804
- IC805
- IC806
- Q808
- IC804
- Q812
- Q801

NOTE

1. This P.C.B connection diagram is viewed from the parts mounted side.
2. The parts which have been mounted on the board can be replaced with those shown with the corresponding wiring symbols listed in the following Table.

P.C.B. pattern diagram indication	Corresponding part symbol	Part Name
		Transistor
		Radiator type transistor
		Diode
		Resistor
		Capacitor (Polarity)
		Capacitor (Non-polarity)

Others

P.C.B. pattern diagram indication	Part Name
IC	IC
S	Switch
RY	Relay
L	Coil
F	Filter
VR	Variable resistor or Semi-fixed resistor

3. The capacitor terminal marked with ⊕ (double circles) shows negative terminal.
4. The diode terminal marked with ⊕ (double circles) shows cathode side.
5. The transistor terminal to which E is affixed shows the emitter.

1

2

3

4

5

6

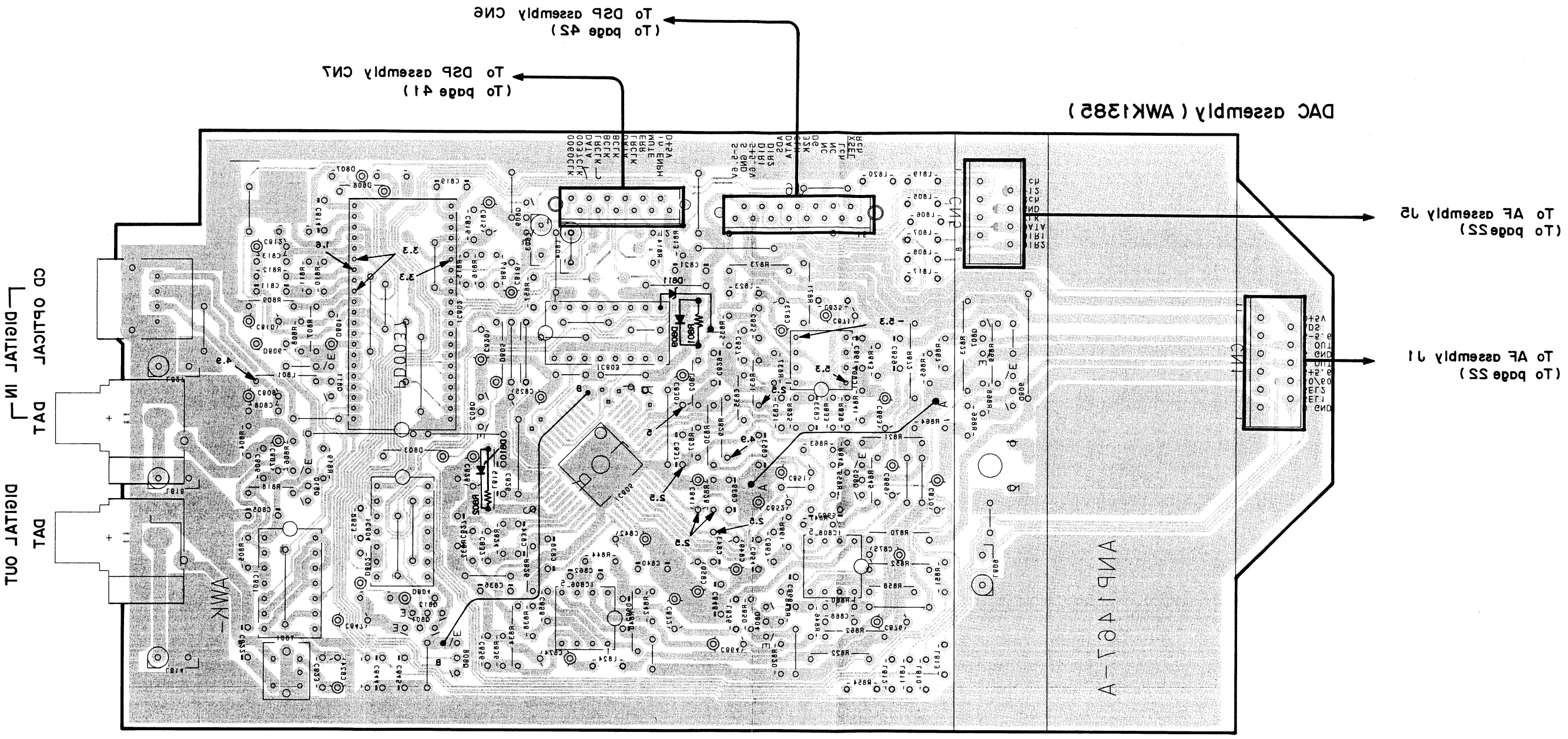

- 0801
- 0815
- IC801
- IC802
- IC803
- IC804
- IC805
- IC806
- IC807
- IC808
- IC809
- IC810
- IC811
- IC812
- IC813
- IC814
- IC815
- IC816
- IC817
- IC818
- IC819
- IC820
- IC821
- IC822
- IC823
- IC824
- IC825
- IC826
- IC827
- IC828
- IC829
- IC830
- IC831
- IC832
- IC833
- IC834
- IC835
- IC836
- IC837
- IC838
- IC839
- IC840
- IC841
- IC842
- IC843
- IC844
- IC845
- IC846
- IC847
- IC848
- IC849
- IC850
- IC851
- IC852
- IC853
- IC854
- IC855
- IC856
- IC857
- IC858
- IC859
- IC860
- IC861
- IC862
- IC863
- IC864
- IC865
- IC866
- IC867
- IC868
- IC869
- IC870
- IC871
- IC872
- IC873
- IC874
- IC875
- IC876
- IC877
- IC878
- IC879
- IC880
- IC881
- IC882
- IC883
- IC884
- IC885
- IC886
- IC887
- IC888
- IC889
- IC890
- IC891
- IC892
- IC893
- IC894
- IC895
- IC896
- IC897
- IC898
- IC899
- IC900
- IC901
- IC902
- IC903
- IC904
- IC905
- IC906
- IC907
- IC908
- IC909
- IC910
- IC911
- IC912
- IC913
- IC914
- IC915
- IC916
- IC917
- IC918
- IC919
- IC920
- IC921
- IC922
- IC923
- IC924
- IC925
- IC926
- IC927
- IC928
- IC929
- IC930
- IC931
- IC932
- IC933
- IC934
- IC935
- IC936
- IC937
- IC938
- IC939
- IC940
- IC941
- IC942
- IC943
- IC944
- IC945
- IC946
- IC947
- IC948
- IC949
- IC950
- IC951
- IC952
- IC953
- IC954
- IC955
- IC956
- IC957
- IC958
- IC959
- IC960
- IC961
- IC962
- IC963
- IC964
- IC965
- IC966
- IC967
- IC968
- IC969
- IC970
- IC971
- IC972
- IC973
- IC974
- IC975
- IC976
- IC977
- IC978
- IC979
- IC980
- IC981
- IC982
- IC983
- IC984
- IC985
- IC986
- IC987
- IC988
- IC989
- IC990
- IC991
- IC992
- IC993
- IC994
- IC995
- IC996
- IC997
- IC998
- IC999
- IC1000

This P.C.B. connection diagram is viewed from the foil side.

DSP assembly (AWK1445)

IC903, IC904, Q901: A/D CONVERTER

IC908: DSP CONTROL IC

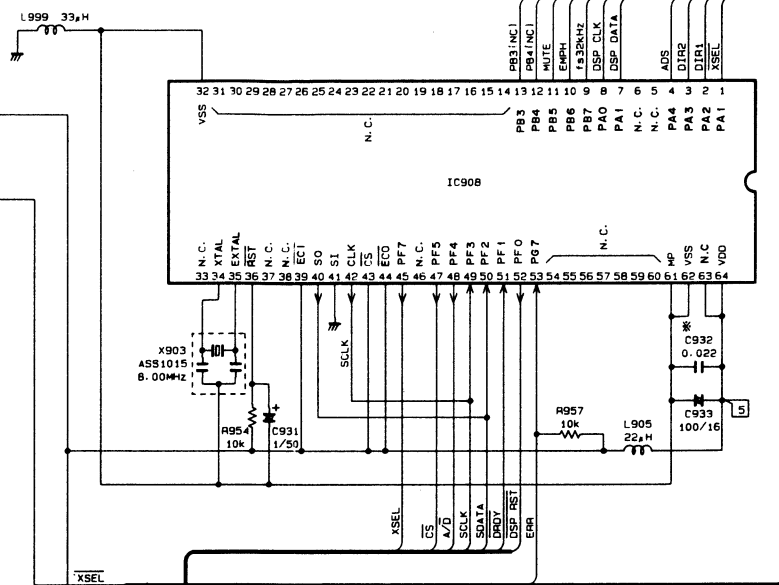
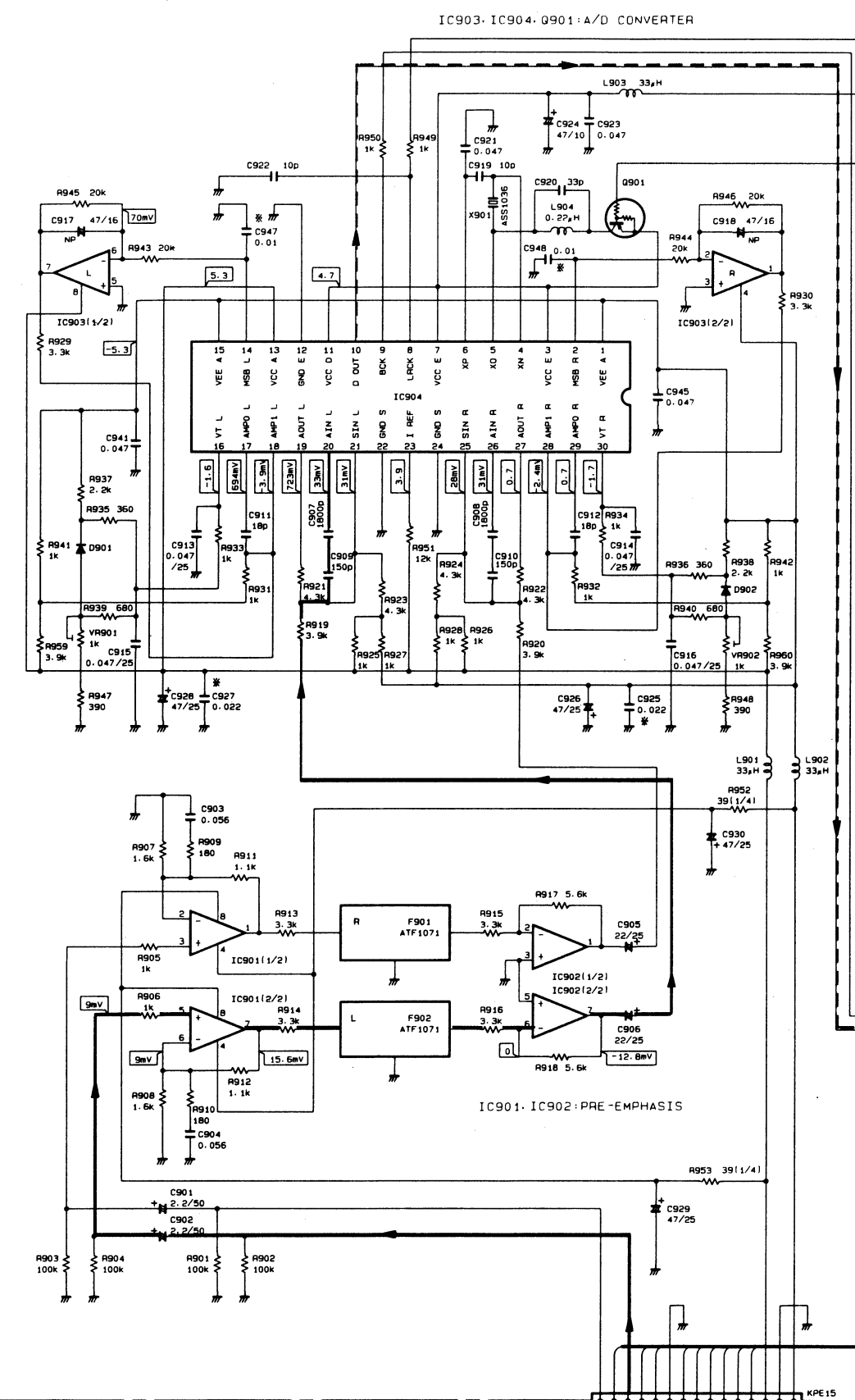

- IC906, 907 MBB1464-12
- IC901-903 RC455BDXP
- IC908 PD6071A
- IC905 PD0055
- IC904 TD6726N
- Q901 DTA143ES
- D901, 902 HSS104-02

IC906, IC907: MEMORY

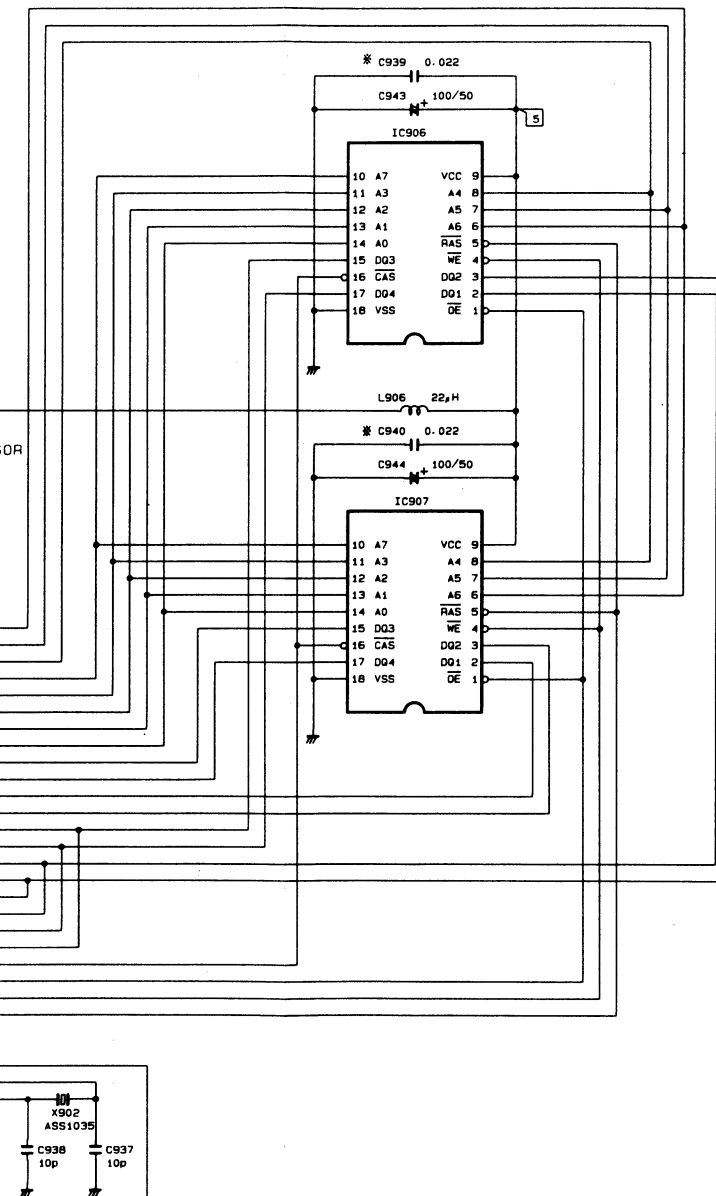

IC905: DSP DIGITAL SOUND PROCESSOR

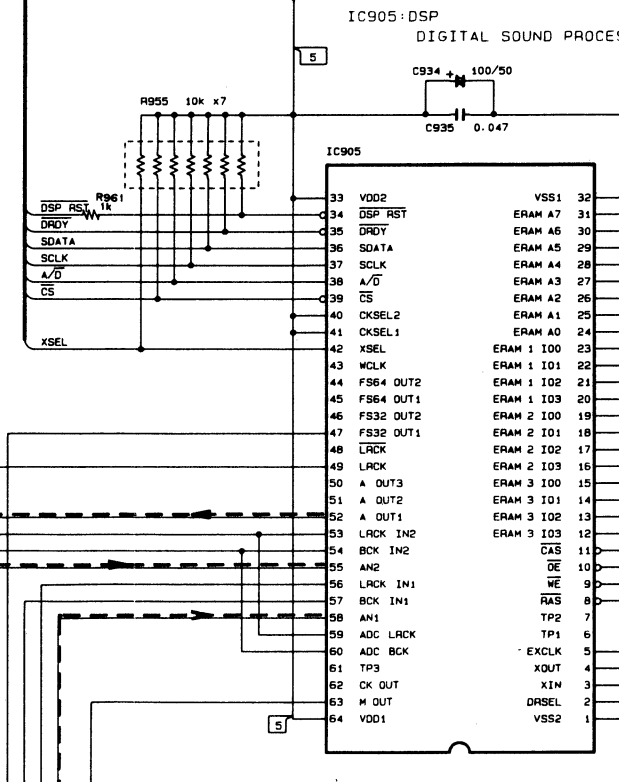

IC901, IC902: PRE-EMPHASIS

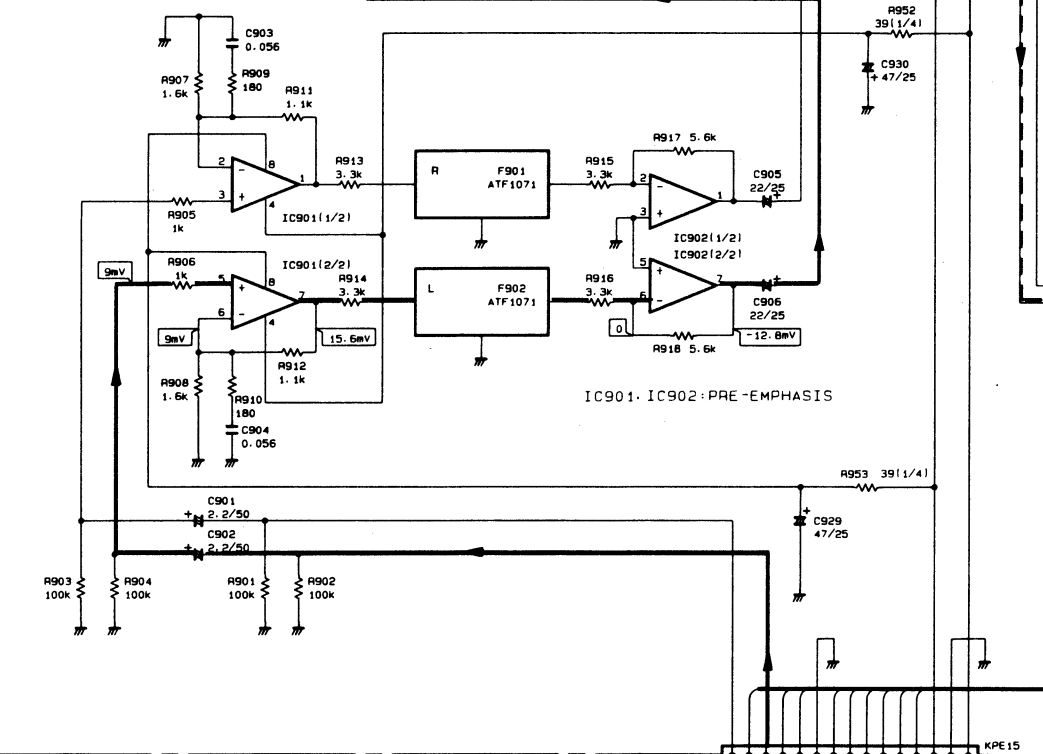

(To page 33)
To DAC assembly J6

(To page 33)
To DAC assembly J7

5. ADJUSTMENTS

1. If the SP-Z570(sound field processor) is connected to the A-Z570, disconnect them. (This makes DSP processing in the A-Z570 flat.)
2. Input 1kHz/600mV to LD INPUT AUDIO Lch and Rch, then turn function to LD, followed by turning the main VR into the center position.
3. Adjust the VR901(Rch) and VR902(Lch) until the distortion of the Lch and Rch is minimized(0.15% or less) at the speaker output.

5. RÉGLAGE

1. Si le SP-Z570(processeur de champ d'ambiance) est connecté au A-Z570, les déconnecter. (Ceci neutralise le traitement DSP dans le A-Z570.)
2. Enter 1kHz/600mV aux bornes gauche et droite d'entrée audio LD(LD INPUT AUDIO), mettre le sélecteur de fonction sur "LD", suivi du réglage de la résistance variable(VR) principale à la position centrale.
3. Régler VR901 (D) et VR902 (G) jusqu'à ce que la distorsion des canaux gauche et droit soit réduite (0,15% ou moins) à la sortie des haut-parleurs.

5. AJUSTE

1. Si el SP-Z570(procesador de campo sonoro) está conectado al A-Z570, desconéctelos. (De este modo el procedo DSP en el A-Z570 será plano.)
2. Introduzca 1kHz/600mV en los canales izquierdo y derecho de INPUT AUDIO del LD, cambie entonces la función a LD, y gire luego la VR principal a la posición central.
3. Ajuste la VR901 (canal derecho) y VR902 (canal izquierdo) hasta que la distorsión de los canales izquierdo y derecho se minimice(0.15% o menos) en la salida del altavoz.

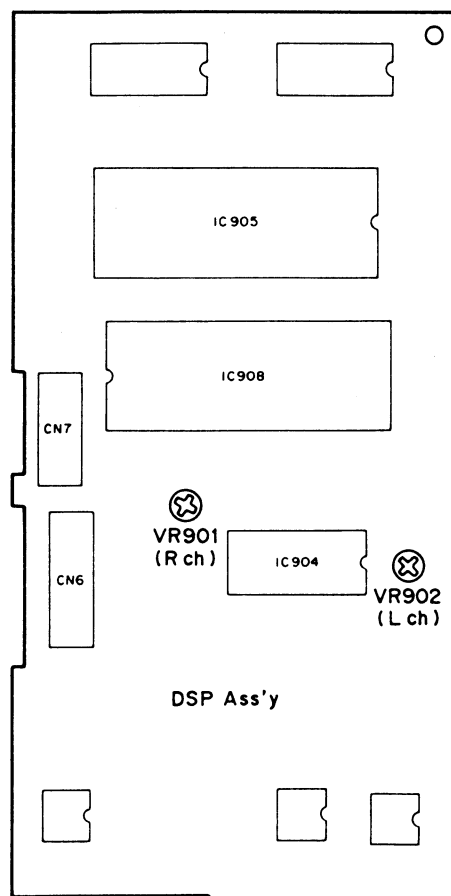

Fig. 5-1. Adjustment location

Fig. 5-1. Emplacements de réglage

Fig. 5-1. Puntos de ajustes

6. FOR HEWZIW TYPE

NOTES:

- Parts without part number cannot be supplied.
- Parts marked by "●" are not always kept in stock. Their delivery time may be longer than usual or they may be unavailable.
- The Δ mark found on some component parts indicates the importance of the safety factor of the part. Therefore, when replacing, be sure to use parts of identical designation.

CONTRAST OF MISCELLANEOUS PARTS

The A-Z570/HEWZIW type is the same as the A-Z570/HE type with the exception of the following sections.

Mark	Symbol & Description	Part No.		Remarks
		A-Z570/HE	A-Z570/HEWZIW	
●	AF assembly	AWZ3404	AWZ3407	
●	POWER assembly	AWZ2611	AWZ2756	
	SP TERMINAL assembly	Non supply	Non supply	
	POWER VR assembly	Non supply	Non supply	
	HEAD PHONE assembly	Non supply	Non supply	
	MIC assembly	Non supply	Non supply	
Δ	AC power cord	ADG1019	ADG1012	
	Operating instructions (German)	ARC1247	
	Operating instructions (Dutch, Swedish, Spanish, Portuguese)	ARC1249	
	Operating instructions (English, German, French, Italian)	ARE1181	

AF assembly (AWZ3407)

The AF assembly(AWZ3407) is the same as the AF assembly(AWZ3404) with the exception of the following sections.

Mark	Symbol & Description	Part No.		Remarks
		AWZ3404	AWZ3407	
	C102, C103	CKDYF103Z50	CKDYF473Z50	
	C341-344, 347-349, 383, 386, 387	CKDYF473Z50	
	C345, 346	CQMA104K50	
	C351, 352	ACG1020	
	C353, 354, 357, 358, 361, 362	CKDYB331K50	
	C355, 356, 359, 360, 363, 364, 373-382	ACG1018	
	C384, 385	CKDYB391K50	
	R201, 202	RD1/8PM102J	RD1/8PM222J	

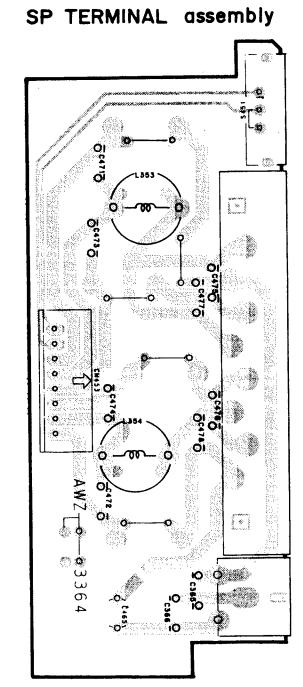
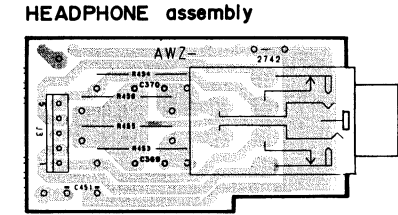
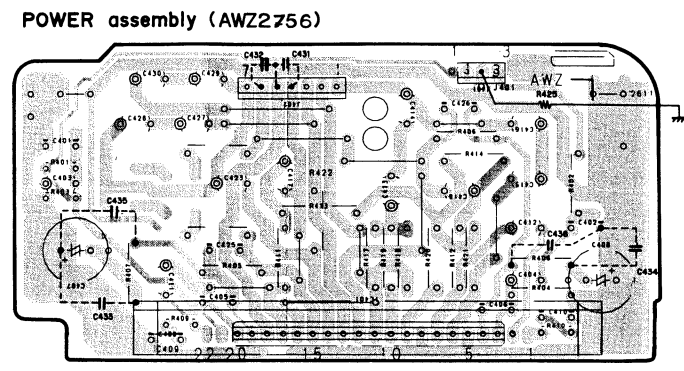
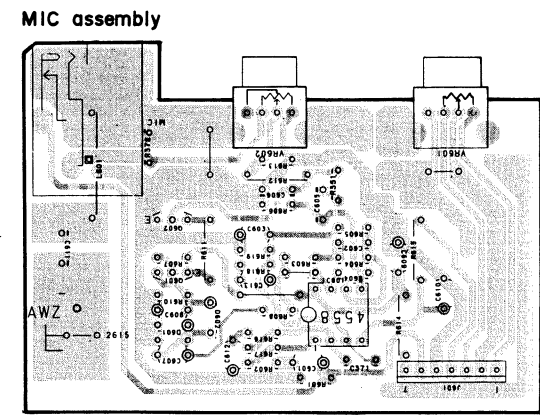
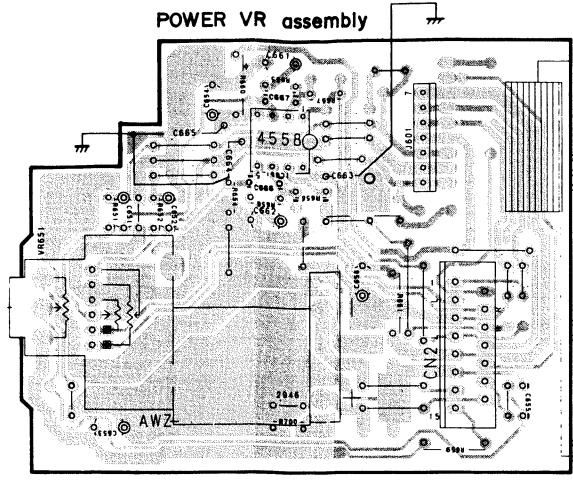
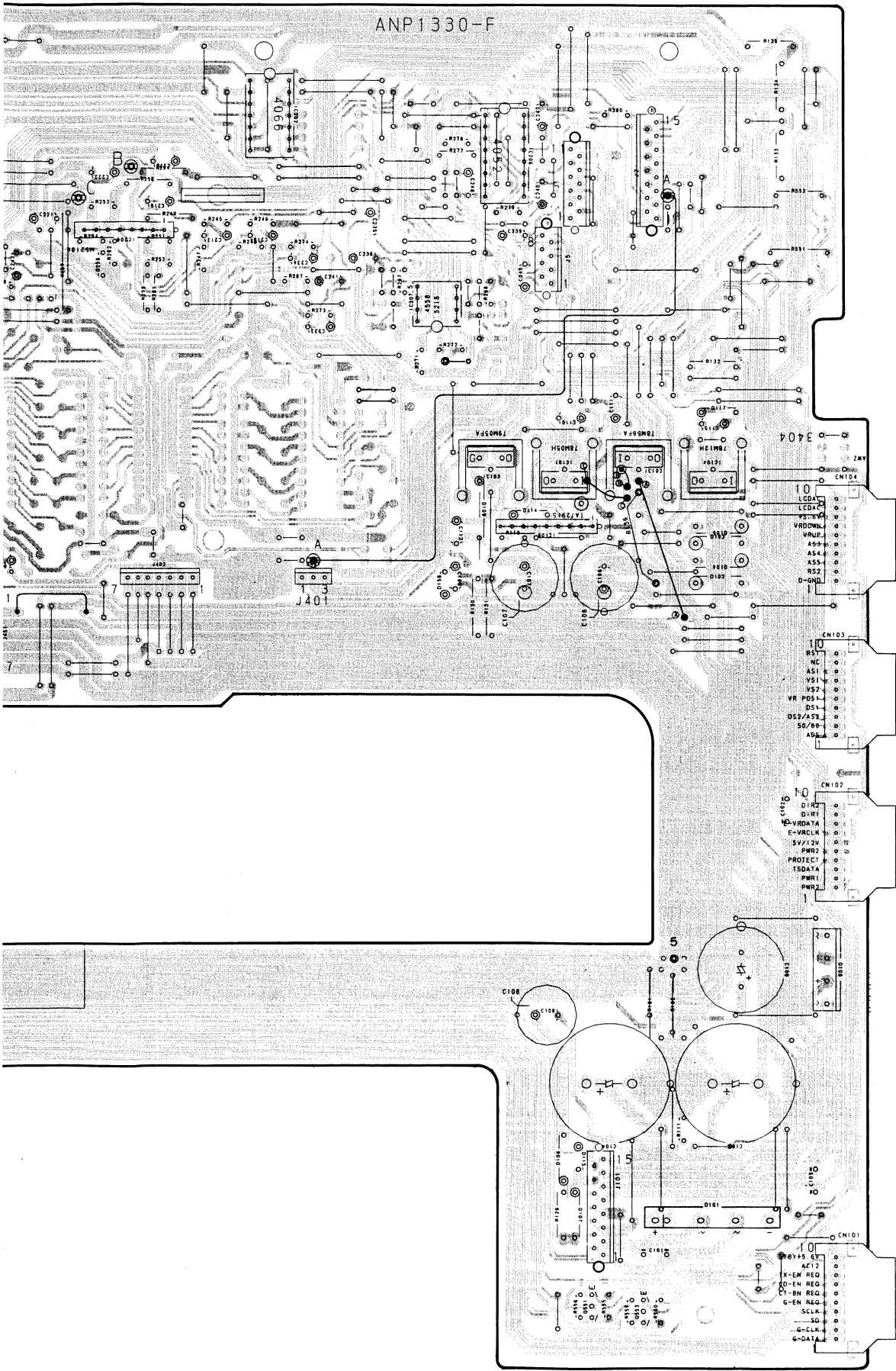

A
B
C
D

A

B

C

D

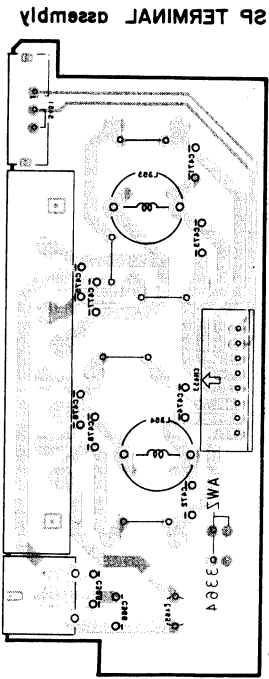
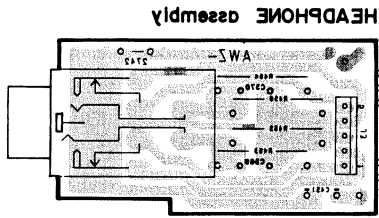
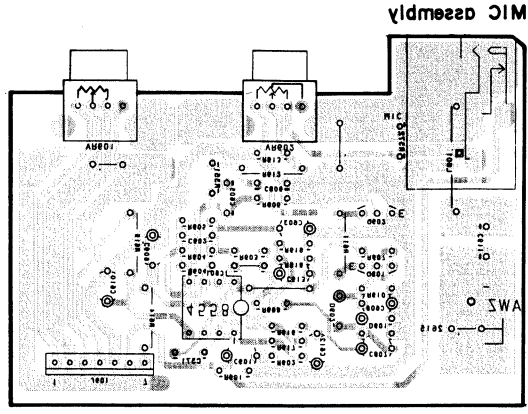

This P.C.B. connection diagram is viewed from the foil side.

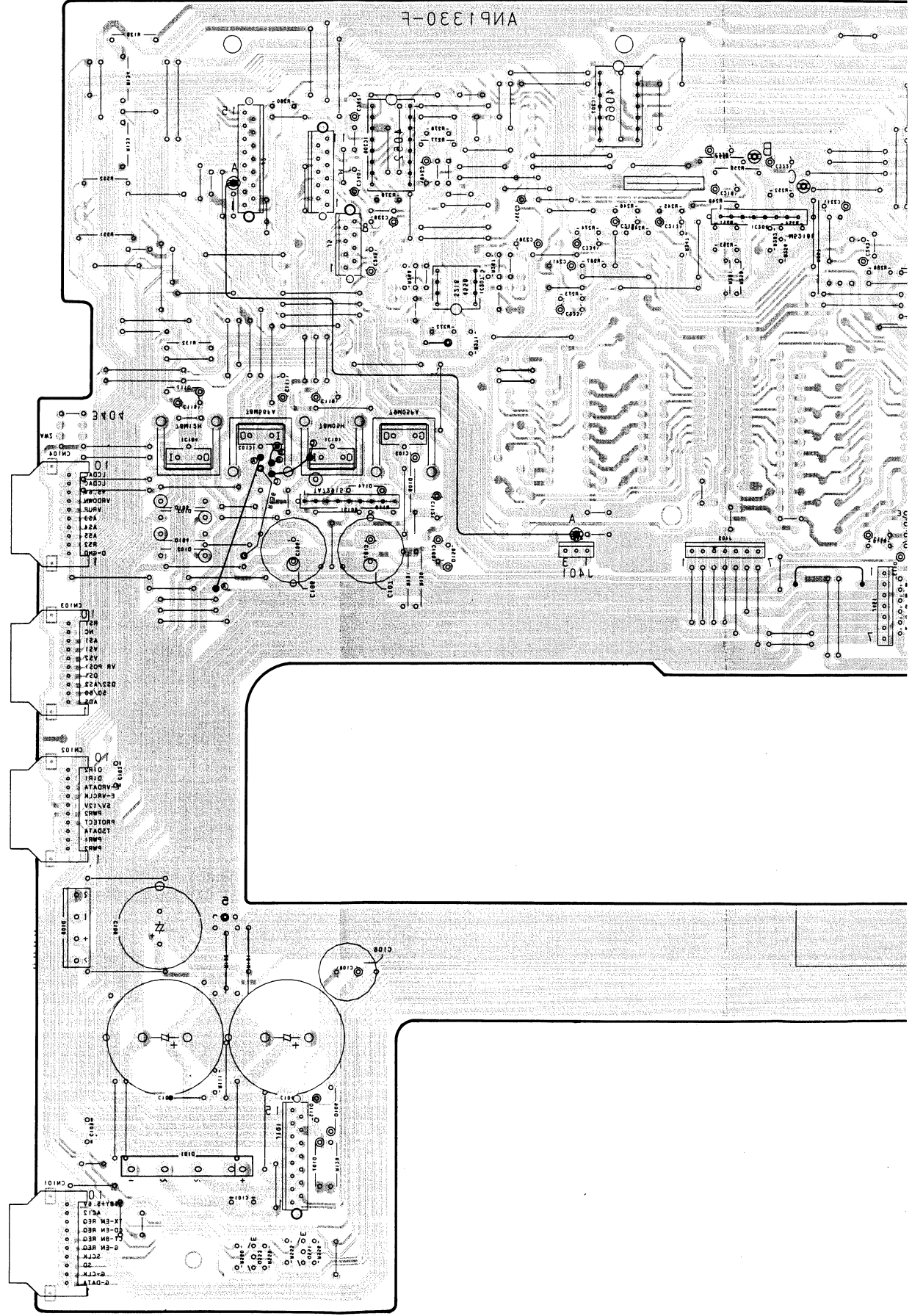
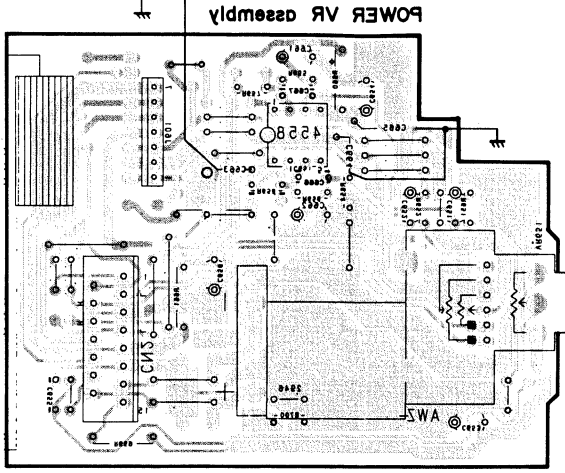
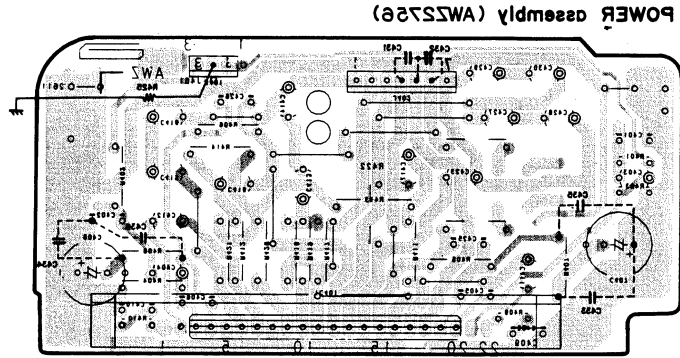

e

8

7

e

2

4

e

8

7

e

2

4

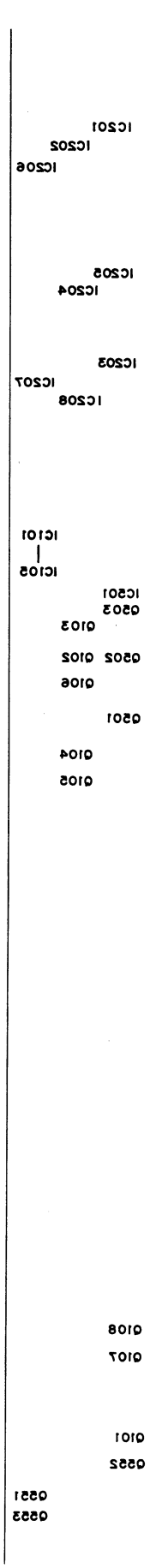
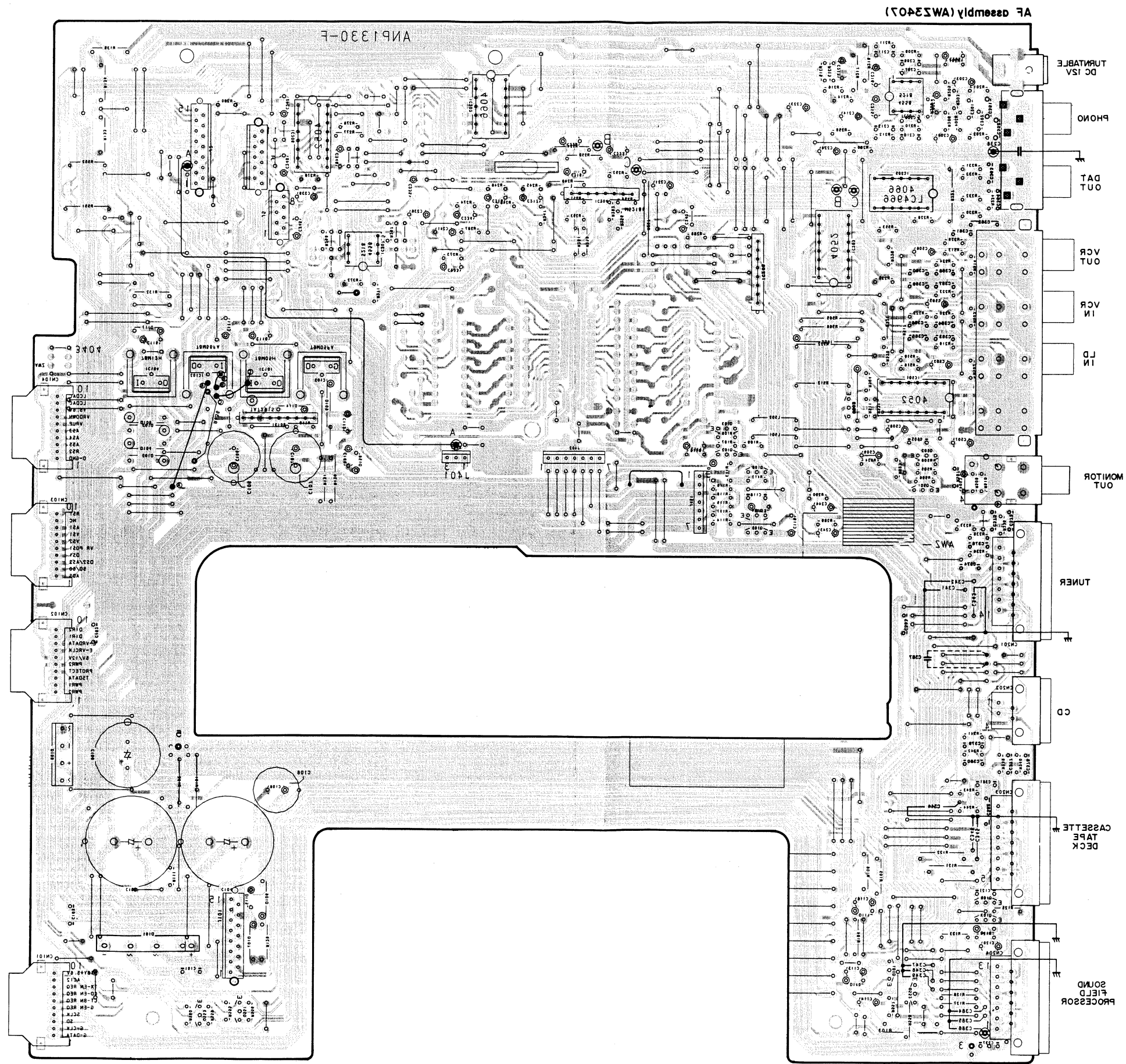
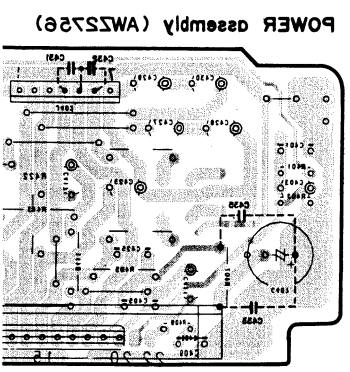
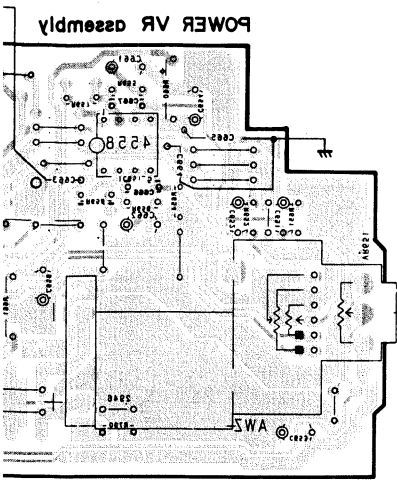

DC ISV TURNTABLE
PHONO
DAT OUT
VCR OUT
VCR IN
LD IN
MONITOR OUT
TUNER
CD
CASSETTE DECK
FIELD SOUND PROCESSOR

foil side.

A

B

C

D

POWER VR assembly

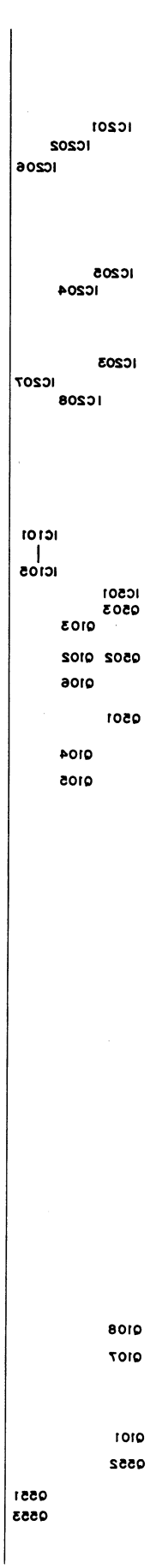
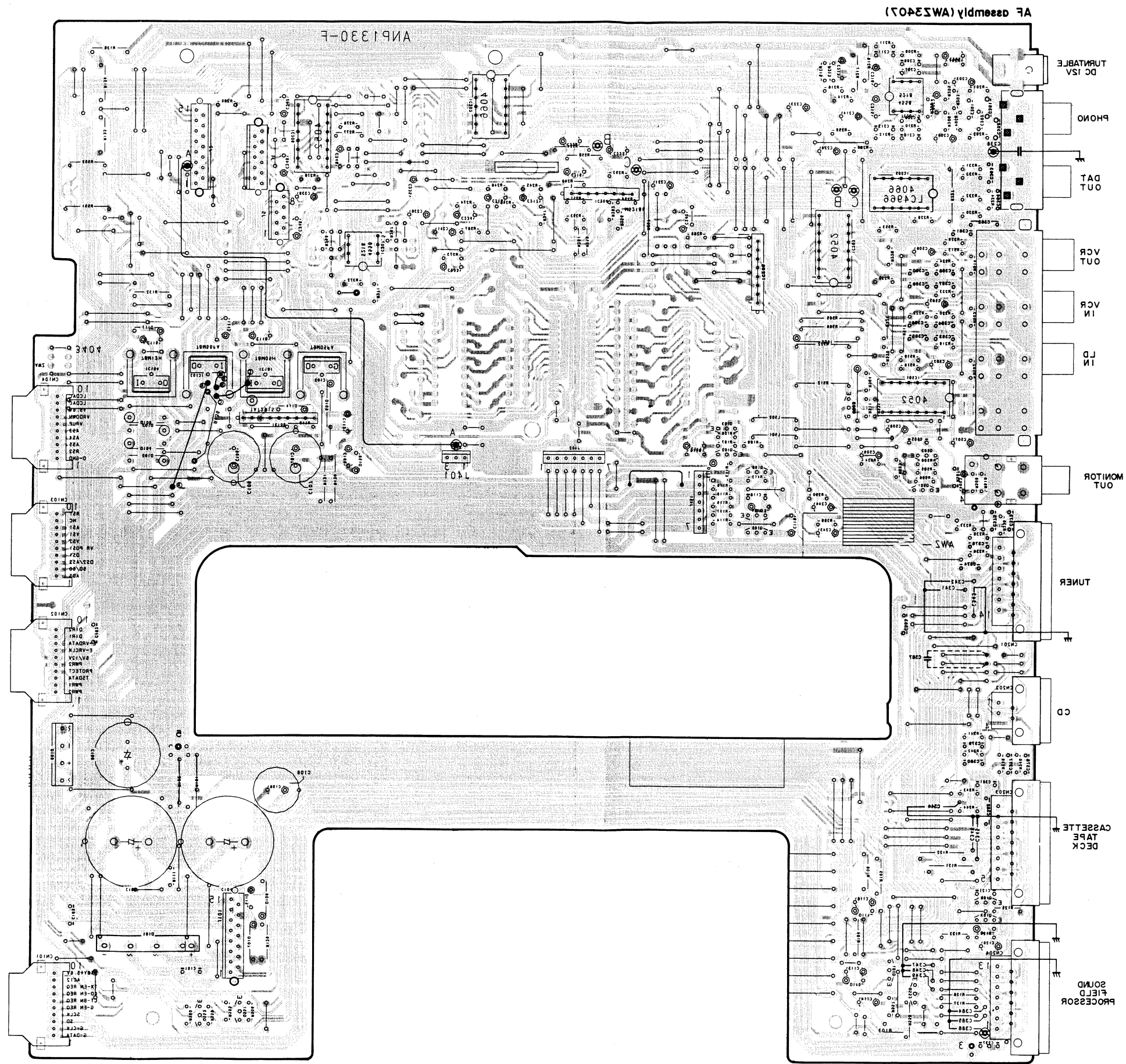
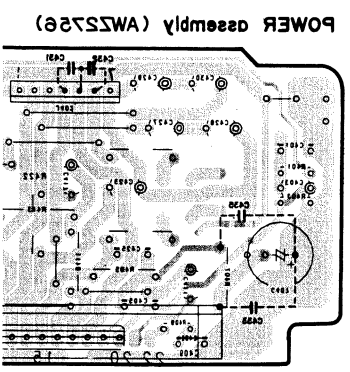

DC ISV TURNTABLE
PHONO
DAT OUT
VCR OUT
VCR IN
LD IN
MONITOR OUT
TUNER
CD
CASSETTE DECK
FIELD SOUND PROCESSOR

foil side.

A

B

C

D

5. ADJUSTMENTS

1. If the SP-Z570(sound field processor) is connected to the A-Z570, disconnect them. (This makes DSP processing in the A-Z570 flat.)
2. Input 1kHz/600mV to LD INPUT AUDIO Lch and Rch, then turn function to LD, followed by turning the main VR into the center position.
3. Adjust the VR901(Rch) and VR902(Lch) until the distortion of the Lch and Rch is minimized(0.15% or less) at the speaker output.

5. RÉGLAGE

1. Si le SP-Z570(processeur de champ d'ambiance) est connecté au A-Z570, les déconnecter. (Ceci neutralise le traitement DSP dans le A-Z570.)
2. Enter 1kHz/600mV aux bornes gauche et droite d'entrée audio LD(LD INPUT AUDIO), mettre le sélecteur de fonction sur "LD", suivi du réglage de la résistance variable(VR) principale à la position centrale.
3. Régler VR901 (D) et VR902 (G) jusqu'à ce que la distorsion des canaux gauche et droit soit réduite (0,15% ou moins) à la sortie des haut-parleurs.

5. AJUSTE

1. Si el SP-Z570(procesador de campo sonoro) está conectado al A-Z570, desconéctelos. (De este modo el procedo DSP en el A-Z570 será plano.)
2. Introduzca 1kHz/600mV en los canales izquierdo y derecho de INPUT AUDIO del LD, cambie entonces la función a LD, y gire luego la VR principal a la posición central.
3. Ajuste la VR901 (canal derecho) y VR902 (canal izquierdo) hasta que la distorsión de los canales izquierdo y derecho se minimice(0.15% o menos) en la salida del altavoz.

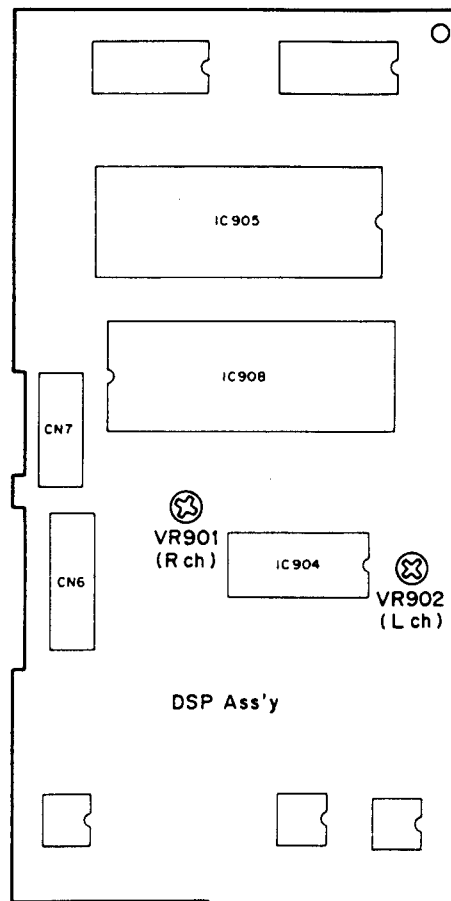

Fig. 5-1. Adjustment location

Fig. 5-1. Emplacements de réglage

Fig. 5-1. Puntos de ajustes

6. FOR HEWZIW TYPE

NOTES:

- Parts without part number cannot be supplied.
- Parts marked by "●" are not always kept in stock. Their delivery time may be longer than usual or they may be unavailable.
- The ⚠ mark found on some component parts indicates the importance of the safety factor of the part. Therefore, when replacing, be sure to use parts of identical designation.

CONTRAST OF MISCELLANEOUS PARTS

The A-Z570/HEWZIW type is the same as the A-Z570/HE type with the exception of the following sections.

Mark	Symbol & Description	Part No.		Remarks
		A-Z570/HE	A-Z570/HEWZIW	
●	AF assembly	AWZ3404	AWZ3407	
●	POWER assembly	AWZ2611	AWZ2756	
	SP TERMINAL assembly	Non supply	Non supply	
	POWER VR assembly	Non supply	Non supply	
	HEAD PHONE assembly	Non supply	Non supply	
	MIC assembly	Non supply	Non supply	
⚠	AC power cord	ADG1019	ADG1012	
	Operating instructions (German)	ARC1247	
	Operating instructions (Dutch, Swedish, Spanish, Portuguese)	ARC1249	
	Operating instructions (English, German, French, Italian)	ARE1181	

AF assembly (AWZ3407)

The AF assembly(AWZ3407) is the same as the AF assembly(AWZ3404) with the exception of the following sections.

Mark	Symbol & Description	Part No.		Remarks
		AWZ3404	AWZ3407	
	C102, C103	CKDYF103Z50	CKDYF473Z50	
	C341-344, 347-349, 383, 386, 387	CKDYF473Z50	
	C345, 346	CQMA104K50	
	C351, 352	ACG1020	
	C353, 354, 357, 358, 361, 362	CKDYB331K50	
	C355, 356, 359, 360, 363, 364, 373-382	ACG1018	
	C384, 385	CKDYB391K50	
	R201, 202	RD1/8PM102J	RD1/8PM222J	

POWER assembly (AWZ2756)

The POWER assembly(AWZ2756) is the same as the POWER assembly(AWZ2611) with the exception of the following sections.

Mark	Symbol & Description	Part No.		Remarks
		AWZ2611	AWZ2756	
	C405, 406	CCDSL470J50	CCDSL221J50	
	C431, 432	CCDSL101K500	
	C433, 434	CCDSL101J50	
	C435, 436	CKDYB331K50	
	R425	RD1/8PM100J	

SP TERMINAL assembly

The SP TERMINAL assembly (HEWZIW type) is the same as the SP TERMINAL assembly (HE type) with the exception of the following sections.

Mark	Symbol & Description	Part No.		Remarks
		HE type	HEWZIW type	
	C365, 366	CFTXA103J50	
	C471-482	CQMXA103J100	
	L353, 354	ATH1002	

POWER VR assembly

The POWER VR assembly (HEWZIW type) is the same as the POWER VR assembly (HE type) with the exception of the following sections.

Mark	Symbol & Description	Part No.		Remarks
		HE type	HEWZIW type	
	C663-665	CKDYB103K50	
	C666, 667	CCDSL470J50	
	R700	RD1/8PM100J	

HEAD PHONE assembly

The HEAD PHONE assembly (HEWZIW type) is the same as the HEAD PHONE assembly (HE type) with the exception of the following sections.

Mark	Symbol & Description	Part No.		Remarks
		HE type	HEWZIW type	
	C369, 370	CKDYX473M25	

MIC assembly

The MIC assembly (HEWZIW type) is the same as the MIC assembly (HE type) with the exception of the following sections.

Mark	Symbol & Description	Part No.		Remarks
		HE type	HEWZIW type	
	C371 (1000p)	ACG1020	
	C372 (100p)	ACG1017	
	C604	ACG1017	ACG1020	
	L601	LAUR56M	
	R351	RD1/8PM222J	

7. PANEL FACILITIES

FRONT PANEL FACILITIES

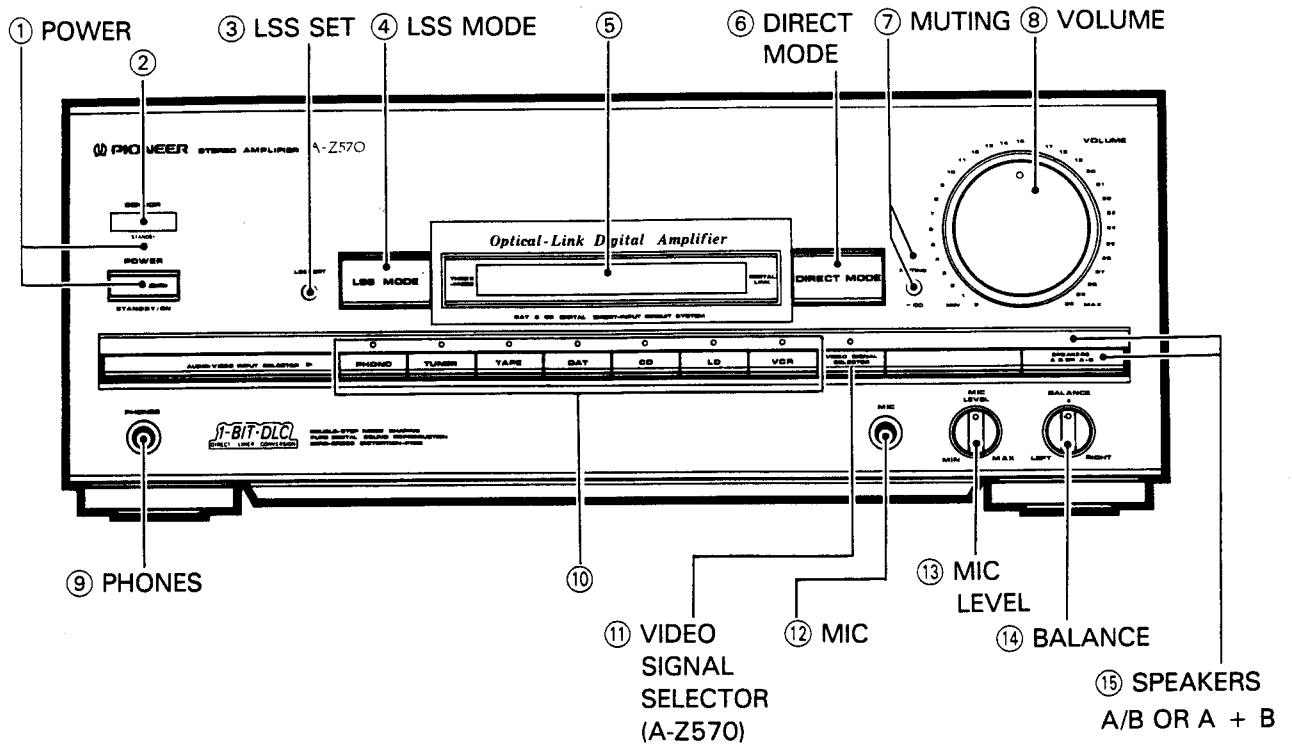

① POWER STANDBY/ON switch/indicator

This is the switch for electric power.

ON When set to the ON position, power is supplied and the unit becomes operational.

STANDBY When set to the STANDBY position, the main power flow is cut and the unit is no longer fully operational. A minute flow of power feeds the unit to maintain operation readiness.

The indicator above the switch lights when the power is STANDBY, and goes out during ON.

② Remote sensor**③ LSS SET button**

Use to operate the Listening Style Selector memory.

④ LSS MODE button

Use to recall the Listening Style Selector.

⑤ Display section

A This lights during listening style selector operation.

B Information such as the component selected with the input selector switch and listening style selector position is displayed.

C This lights when you select CD and DAT direct mode.

D This lights when you play a CD.

E This shows the position of the listening style selector.

F This lights when you play a CD.

G This lights when you can select CD and DAT direct mode.

⑥ DIRECT MODE button

Use this when you want by-pass sound quality adjustment circuitry and listen to a CD or DAT in the direct mode.

⑦ MUTING button/indicator

Use when you want to temporarily cut sound during playback. Press again to return to the previous volume level.

⑧ VOLUME control**⑨ PHONES jack**

For stereo headphones.

NOTE:

There is no output from the speakers when headphones are plugged into PHONES jack.

⑩ Input selector buttons/indicators**[PHONO]**

Press to play records on a turntable connected to the PHONO input jacks.

[TUNER]

Press to listen to radio broadcast.

[TAPE]

Press to listen to cassette tape.

[DAT]

Press to listen to a DAT playing on a digital audio tape deck connected to the DAT jacks.

[CD]

Press to listen to compact disc.

[LD]

Press to play an LD on a video disc player connected to the LD input jacks.

[VCR]

Press to play a tape on a video cassette recorder connected to the VCR jacks.

⑪ VIDEO SIGNAL SELECTOR switch/indicator

Pressing this switch lets you select video sources independent of those selected with the input selector switches. Each time you press it, the source changes.

⑫ MIC (microphone) jack

This is a standard jack for connecting a microphone.

NOTE:

Mike mixing is not possible when CD DIRECT or DAT DIRECT are ON.

⑬ MIC LEVEL control

Used for adjusting the volume of microphone.

⑭ BALANCE control

Used for changing the balance between left and right channels. Usually set to the center position.

⑮ SPEAKERS button (A/ B OR A + B)/indicator

When the SPEAKER MODE selector switch on the rear panel is set to the A/B (left), use this button to switch between sound from speakers A only, and sound from speakers B only.

When the SPEAKER MODE selector switch is set to the A/A + B (right), use this button to switch between sound from speakers A only, and sound from both speakers A and B.

Refer to page 50 No.⑥ concerning SPEAKER MODE selector switch.

Rear panel SPEAKER MODE switch	SPEAKERS	
	Indicator off	Indicator lit
A/B	A	B
A/A + B	A	A + B

NOTE:

If speakers A and B are not both connected, there will be no sound when the button is set for A + B.

REAR PANEL FACILITIES

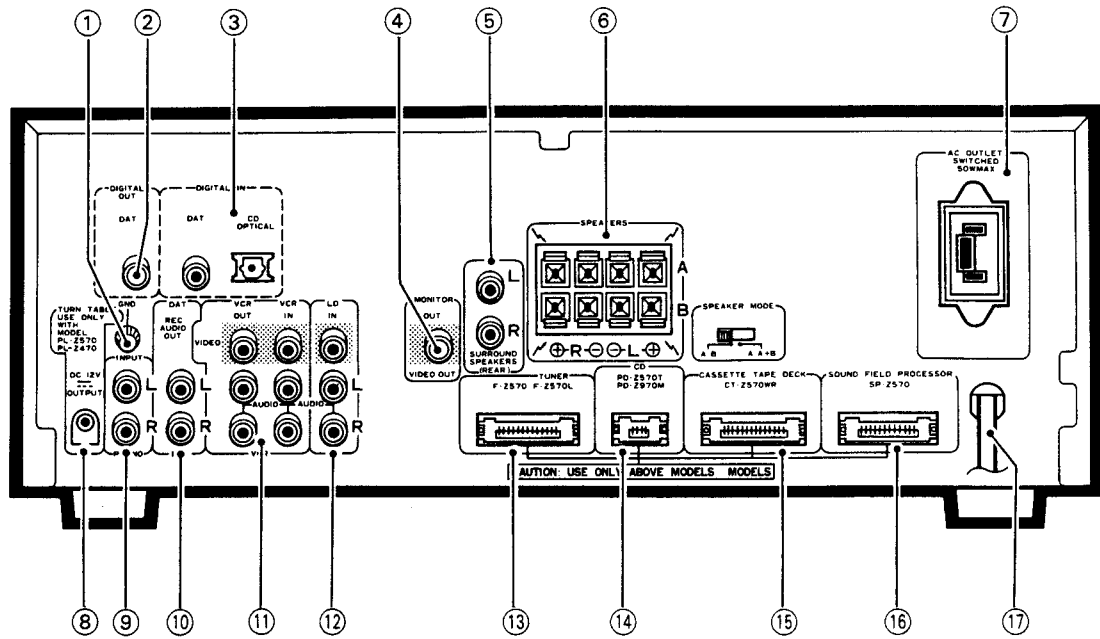

① Ground terminal (GND)

Connect this to the ground terminal on the turntable (except for PL-Z570/PL-Z470).

② DIGITAL OUT (DAT)

Outputs digital signal taken from CD player optical input.

A digital audio tape deck's digital input jack (coaxial cable input) can be connected here.

Consult with your dealer to see if it's possible to connect your digital audio tape deck.

③ DIGITAL IN jacks

[DAT]

A digital audio tape deck's digital output jack (coaxial cable output) can be connected here.

Consult with your dealer to see if it's possible to connect your digital audio tape deck.

[CD]

Connect a CD player's OPTICAL OUT jack.

④ MONITOR OUT jack

You can connect a TV with a video input jack or monitor TV here. The picture from an LD player or video cassette recorder connected to the video input jack is output.

⑤ SURROUND SPEAKERS jacks

Connect the Surround speaker systems.

NOTE:

Connect a speaker system having a nominal impedance of 16 Ω or more.

⑥ SPEAKERS terminals and SPEAKER MODE selector switch

A: Connect to a first set of speakers

B: Connect to a second set of speakers

Set the selector switch to the A/B (left), and use the SPEAKERS button on the front panel to switch between sound from speakers A only, and sound from speakers B only.

If you set the selector switch to the A/A + B (right), use the SPEAKERS button on the front panel to switch between sound from speakers A only, and sound from both speakers A and B.

NOTE:

Connect a speaker system having a nominal impedance ranging from 8 Ω to 16 Ω .

⑦ AC OUTLET (SWITCHED 50 W MAX)

Power supplied through this outlet is turned on and off by the amplifier's POWER switch. Total electrical power consumption of connected equipment should not exceed 50 W.

PD-Z570T and PD-Z970M CD player power cords can be connected.

NOTE:

Do not connect appliances with high power consumption such as heaters, irons, or television sets to the AC OUTLET in order to avoid overheating or fire risk.

This can cause the amplifier to malfunction.

⑧ TURNTABLE (DC 12 V OUTPUT) jack

This jack supplies power to the turntable. (PL-Z470/PL-Z570)

⑨ PHONO input jacks

Connect the output cord of the turntable to these jacks.

⑩ DAT REC OUT jacks

Connect to audio input jacks of the digital audio tape deck.

⑪ VCR jacks

IN: Connect to the output jacks of VCR.

OUT: Connect to the input jacks of VCR.

⑫ LD input jacks

Connect to the output jacks of the LD player.

⑬ TUNER jack

Connect the tuner cord here.

⑭ CD jack

Connect the compact disc player (PD-Z570T/PD-Z970M) cord here.

⑮ CASSETTE TAPE DECK jack

Connect the cassette deck cord here.

⑯ SOUND FIELD PROCESSOR jack

Connect the sound field processor cord here.

⑰ Power cord

Connect this to the AC wall socket.

2.2 EXPLODED VIEWS

A

B

C

D

