

Service Manual

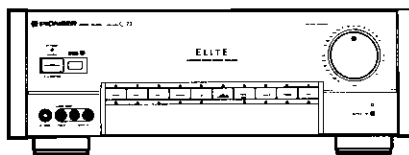

ORDER NO.
ARP2106

STEREO CONTROL AMPLIFIER

C-72

C-73

MODELS C-72 AND C-73 HAVE FOLLOWING VERSIONS:

Type	Applicable model		Power requirement	Destination
	C-72	C-73		
KU/CA	○	—	AC120V only	U.S.A. and Canada
SD	○	—	AC110V, 120V – 127V, 220V, 240V (Switchable)	Kingdom of Saudi Arabia and General market
HEZ	—	○	AC220V, 240V (Switchable) *	West Germany
HB	—	○	AC220V, 240V (Switchable) *	United Kingdom

* Change the connection of the power transformer lead wire.

- This manual is applicable to the C-72/KU/CA, SD, C-73/HEZ and HB types.
- As to the C-72/SD type, refer to page 44.
- As to the C-73/HB type, refer to page 72.

CONTENTS

1. SAFETY INFORMATION	2	4. FOR C-72/SD TYPE	44
2. EXPLODED VIEWS, PACKING AND PARTS LIST (FOR C-72/KU/CA AND C-73/HEZ TYPES)	4	5. FOR C-73/HEZ TYPE	45
3. FOR C-72/KU/CA TYPE	11	6. FOR C-73/HB TYPE	72
		7. IC INFORMATION	73

This service manual is intended for qualified service technicians; it is not meant for the casual do-it-yourselfer. Qualified technicians have the necessary test equipment and tools, and have been trained to properly and safely repair complex products such as those covered by this manual.

Improperly performed repairs can adversely affect the safety and reliability of the product and may void the warranty. If you are not qualified to perform the repair of this product properly and safely, you should not risk trying to do so and refer the repair to a qualified service technician.

WARNING

Lead in solder used in this product is listed by the California Health and Welfare agency as a known reproductive toxicant which may cause birth defects or other reproductive harm (California Health & Safety Code, Section 25249.5).

When servicing or handling circuit boards and other components which contain lead in solder, avoid unprotected skin contact with the solder. Also, when soldering do not inhale any smoke or fumes produced.

1. SAFETY INFORMATION

(FOR USA MODEL ONLY)

1. SAFETY PRECAUTIONS

The following check should be performed for the continued protection of the customer and service technician.

LEAKAGE CURRENT CHECK

Measure leakage current to a known earth ground (water pipe, conduit, etc.) by connecting a leakage current tester such as Simpson Model 229-2 or equivalent between the earth ground and all exposed metal parts of the appliance (input/output terminals, screwheads, metal overlays, control shaft, etc.). Plug the AC line cord of the appliance directly into a 120V AC 60Hz outlet and turn the AC power switch on. Any current measured must not exceed 0.5mA.

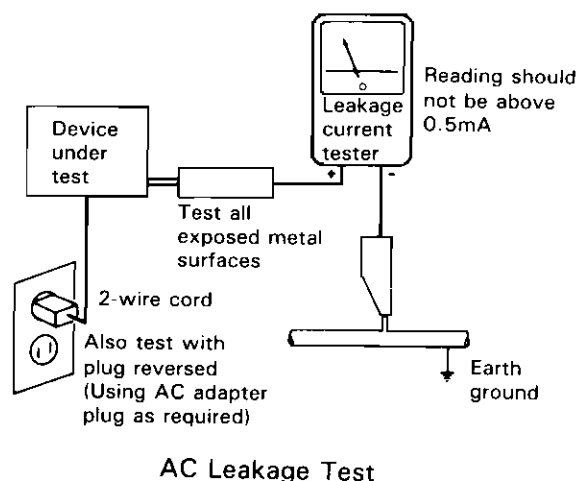

ANY MEASUREMENTS NOT WITHIN THE LIMITS OUTLINED ABOVE ARE INDICATIVE OF A POTENTIAL SHOCK HAZARD AND MUST BE CORRECTED BEFORE RETURNING THE APPLIANCE TO THE CUSTOMER.

2. PRODUCT SAFETY NOTICE

Many electrical and mechanical parts in the appliance have special safety related characteristics. These are often not evident from visual inspection nor the protection afforded by them necessarily can be obtained by using replacement components rated for voltage, wattage, etc. Replacement parts which have these special safety characteristics are identified in this Service Manual.

Electrical components having such features are identified by marking with a Δ on the schematics and on the parts list in this Service Manual.

The use of a substitute replacement component which does not have the same safety characteristics as the PIONEER recommended replacement one, shown in the parts list in this Service Manual, may create shock, fire, or other hazards.

Product Safety is continuously under review and new instructions are issued from time to time. For the latest information, always consult the current PIONEER Service Manual. A subscription to, or additional copies of, PIONEER Service Manual may be obtained at a nominal charge from PIONEER.

MEMO

2. EXPLODED VIEWS, PACKING AND PARTS LIST (FOR C-72/KU/CA AND C-73/HEZ TYPES)

2.1 PACKING

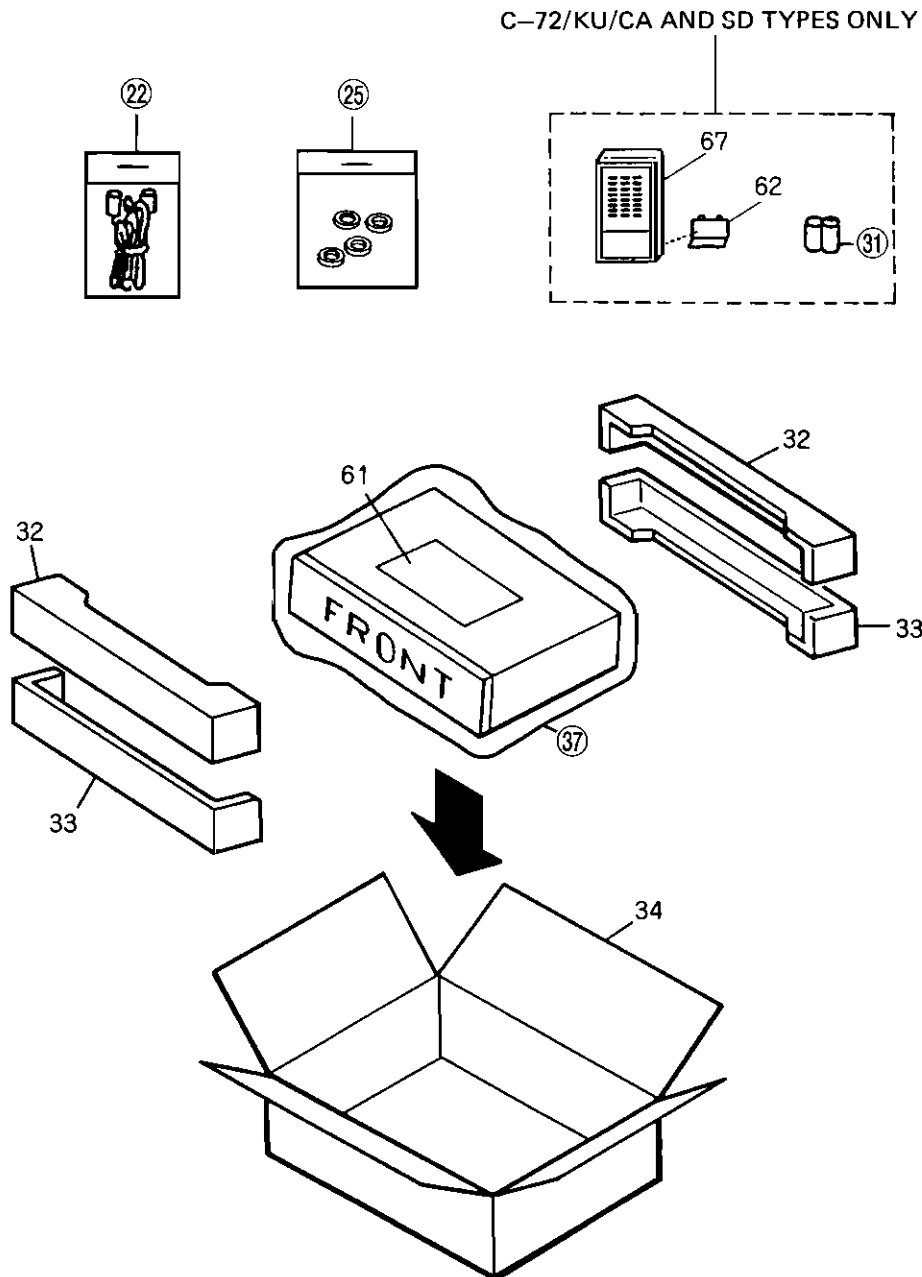

2.2 MAIN BLOCK

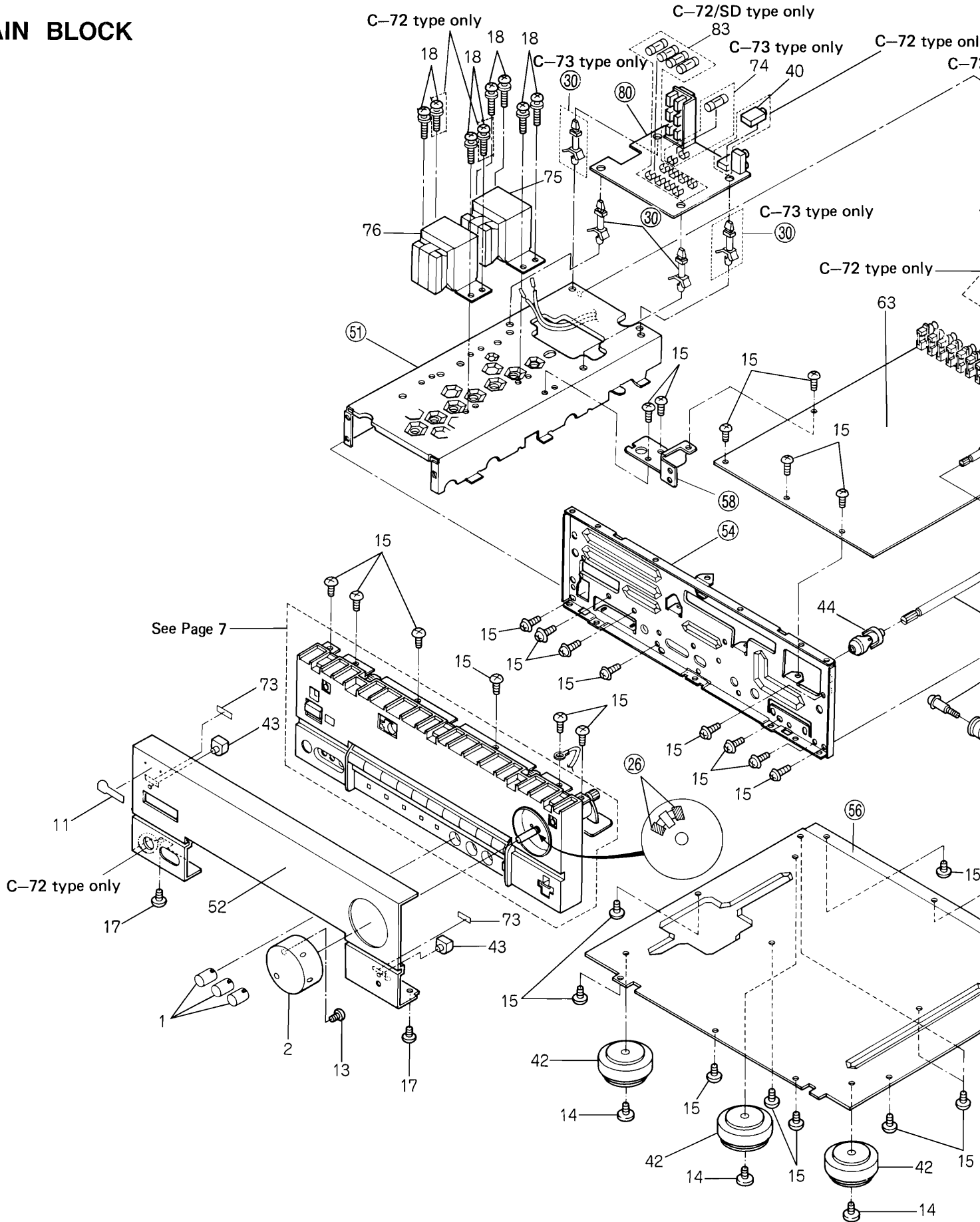

only

type only

40

C-72 type only

C-72 type only

C-72 type only

C-72 type only

73 type only

C-72 type only

C-73 type only

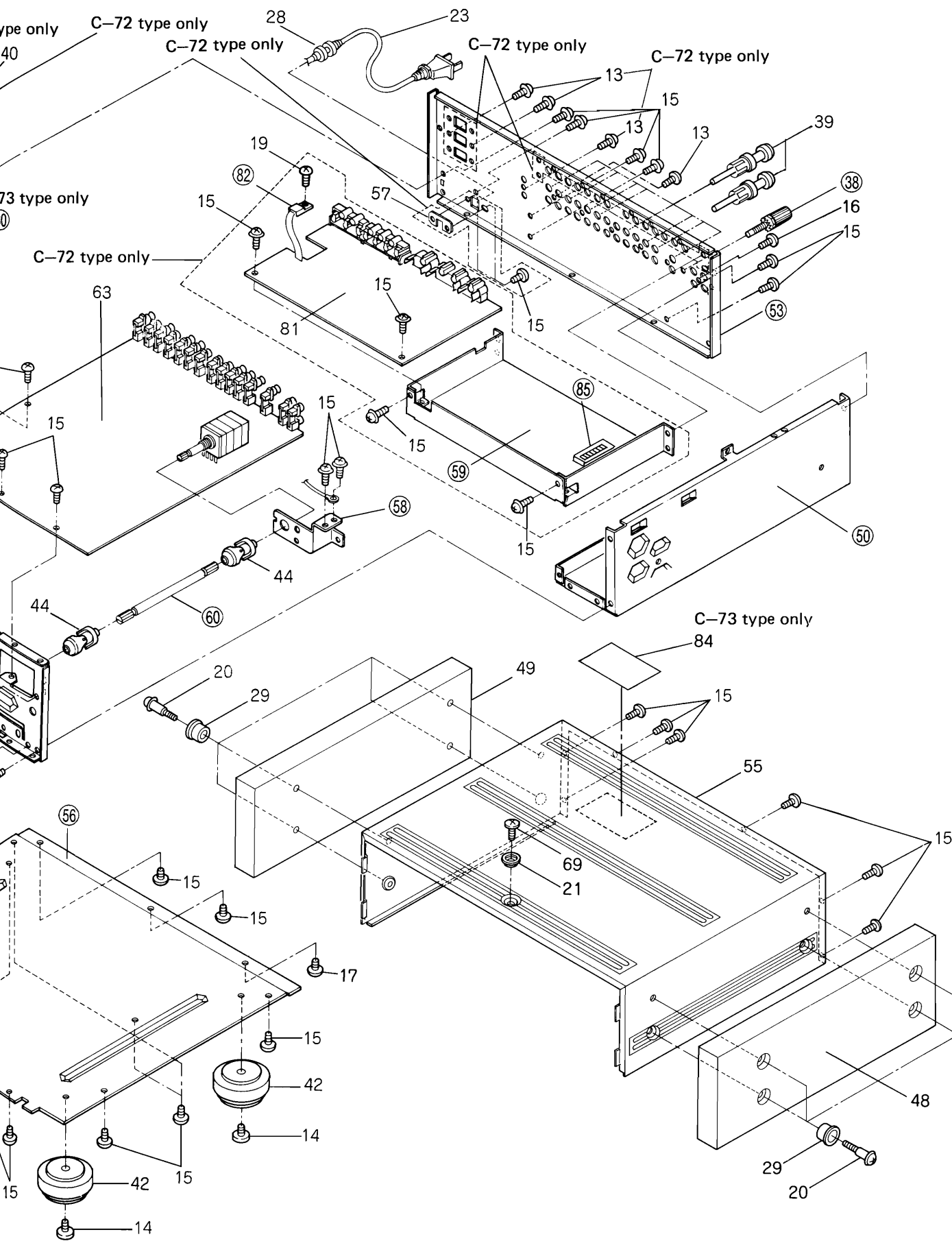

A

B

C

D

3. FOR C-72/KU/CA TYPE

3.1 SCHEMATIC DIAGRAM AND P.C. BOARDS CONNECTION DIAGRAM

AF ASS'Y AWK1301

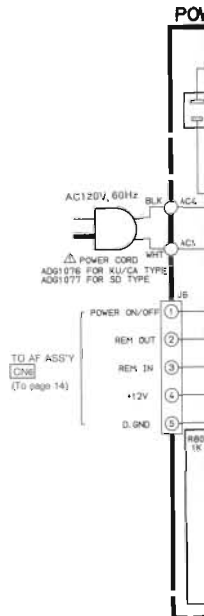
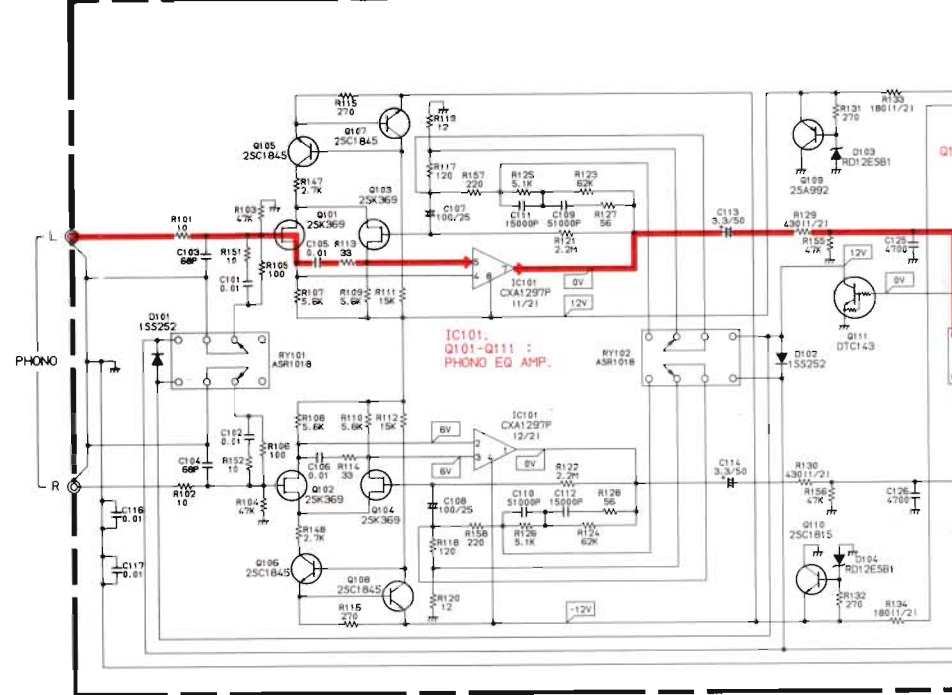

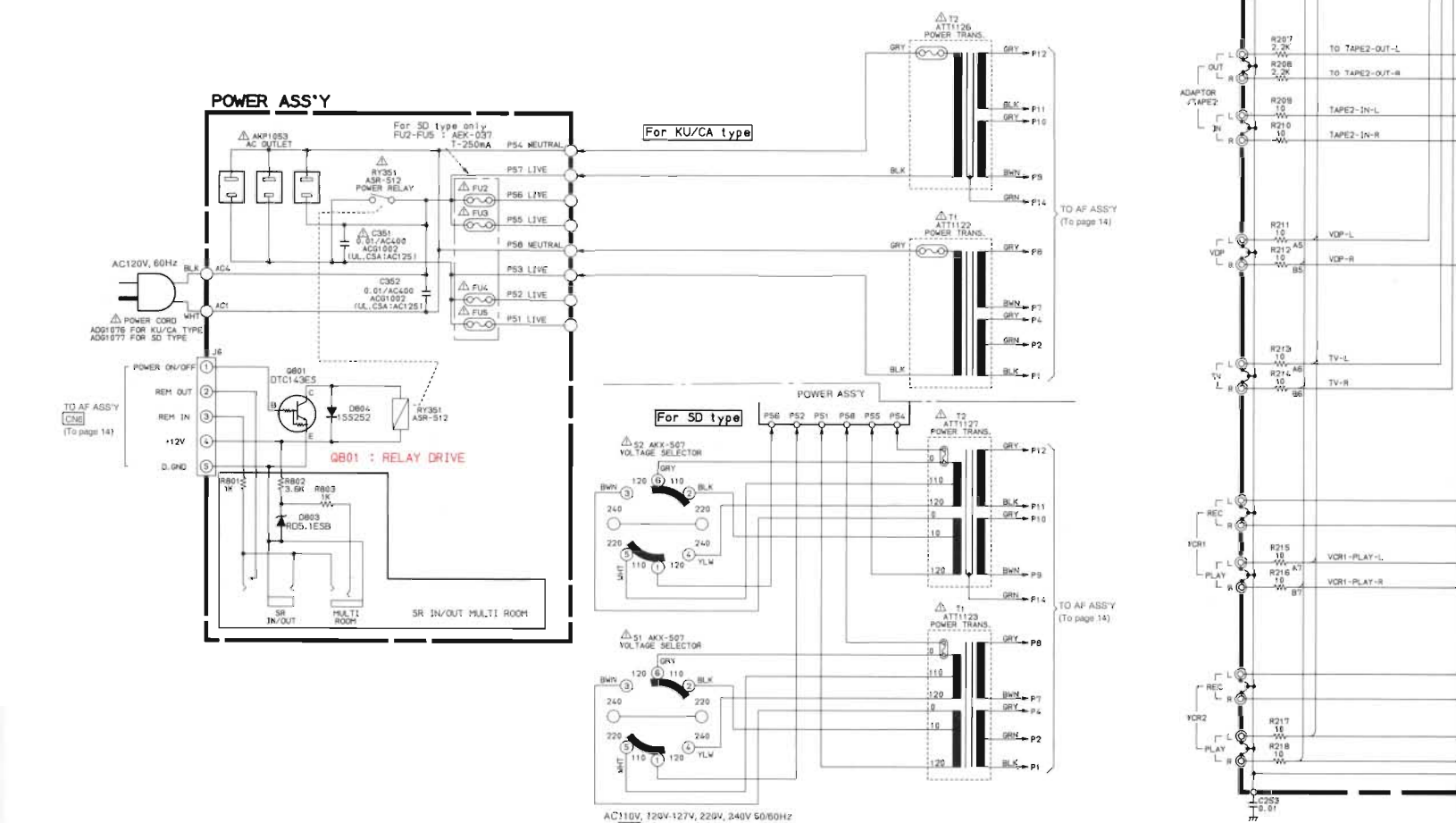
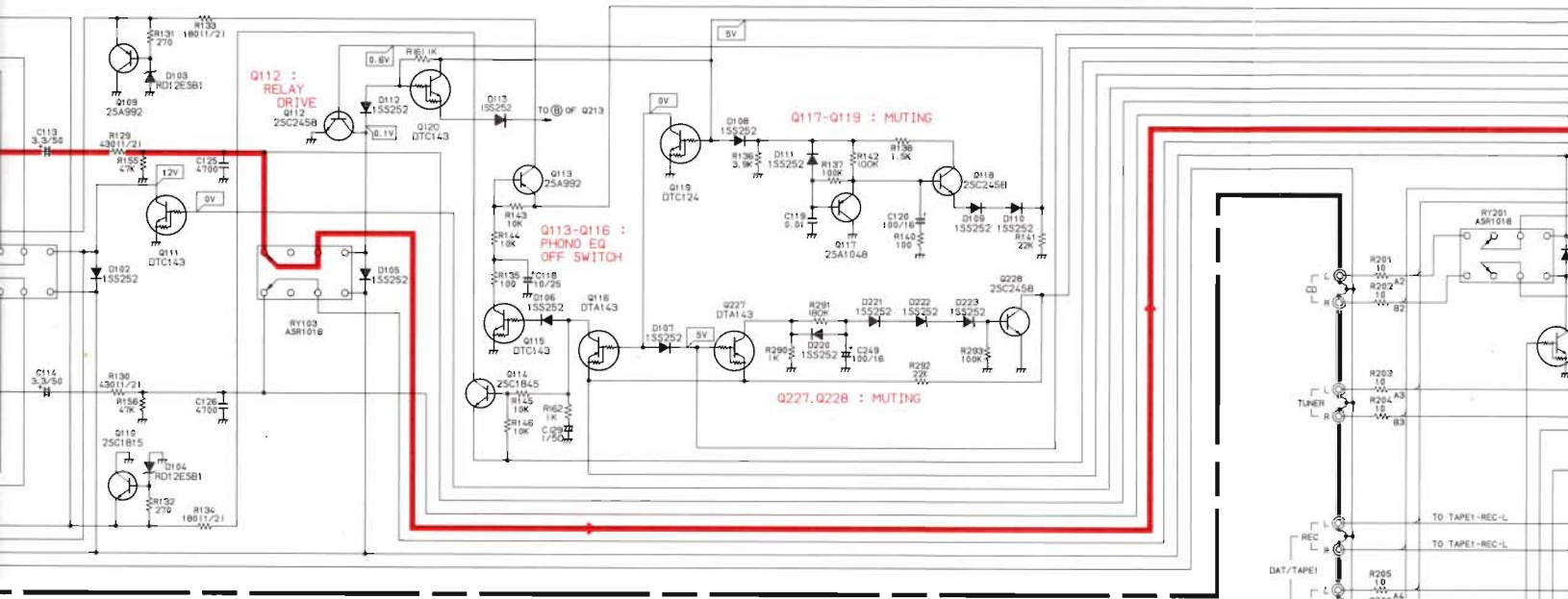

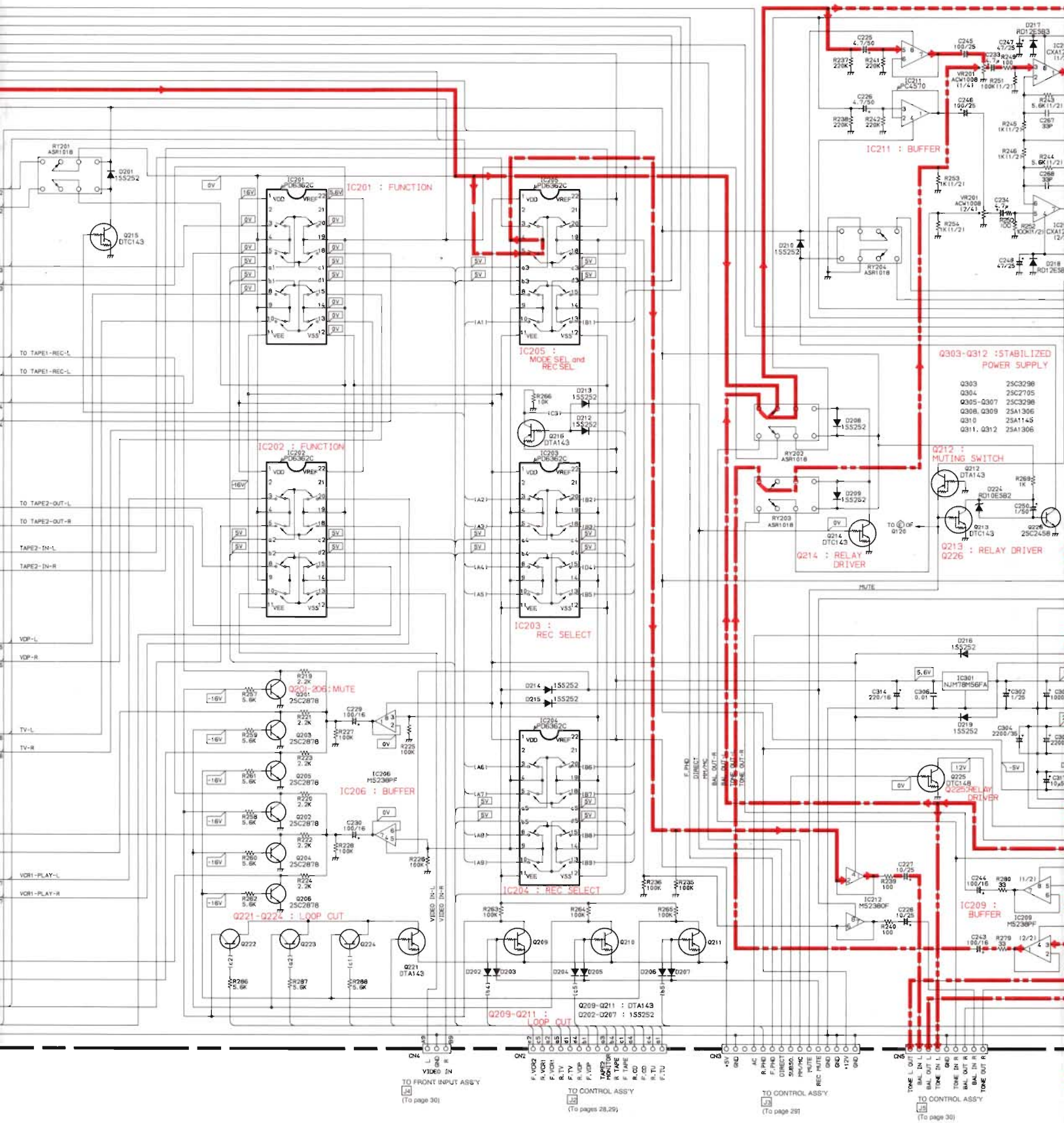

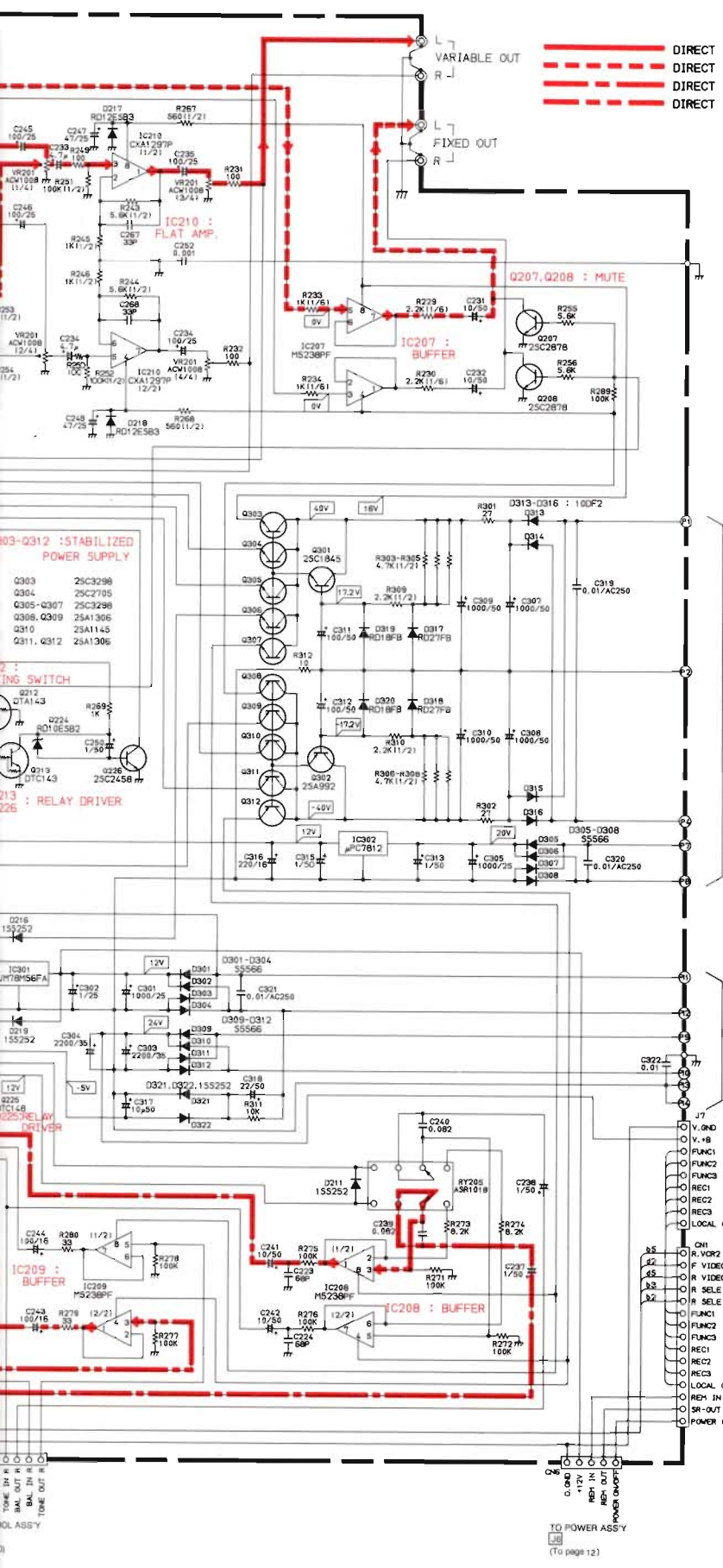

1. RESISTORS:
 Indicated in Ω, 1/8, 1/4W, ±5% tolerance unless otherwise noted
 K; kΩ, M; MΩ, (F); ±1%, (G); ±2%, (K); ±10%, (M); ±20% tolerance.

2. CAPACITORS:
 Indicated in capacity (μF) / voltage (V) unless otherwise noted p; pF.
 Indication without voltage is 50V except electrolytic capacitor.

3. VOLTAGE CURRENT:
 □ : DC voltage (V) at no input signal.
 Value in () is DC voltage at rated power.
 ◁mA : DC current at no input signal.

4. OTHERS

- ◁ : Signal route.
- ⊙ : Adjusting point.
- △ : The mark found on some component parts indicates the importance of the safety factor of the part. Therefore, when replacing, be sure to use parts of identical designation.
- * : marked capacitor and resistor have parts number.
- This is the basic schematic diagram, but the actual circuit may vary due to improvements in design.

- 5. SWITCHES (The underline indicates the switch position)**
- CONTROL Assembly
- S701 : POWER SW (STANDBY-ON)
 - S702 : LD
 - S703 : TV/AUX
 - S704 : VCR1
 - S705 : VCR2
 - S706 : VIDEO
 - S707 : PHONO
 - S708 : TAPE 2/MONITOR
 - S709 : CD
 - S710 : TUNER
 - S711 : TAPE 1/DAT
 - S712 : MUTING
 - S713 : SUBSONIC
 - S714 : PHONO-SEL
 - S715 : DIRECT
 - S716 : V-SEL
 - S717 : REC-SEL
- Outside of P.C. Board
- S2 : VOLTAGE SELECTOR AKX-507 (SD type only)
 - S1 : VOLTAGE SELECTOR AKX-507 (SD type only)

A

B

C

D

POWER ASS'Y

AF ASS'Y (AWK1301)

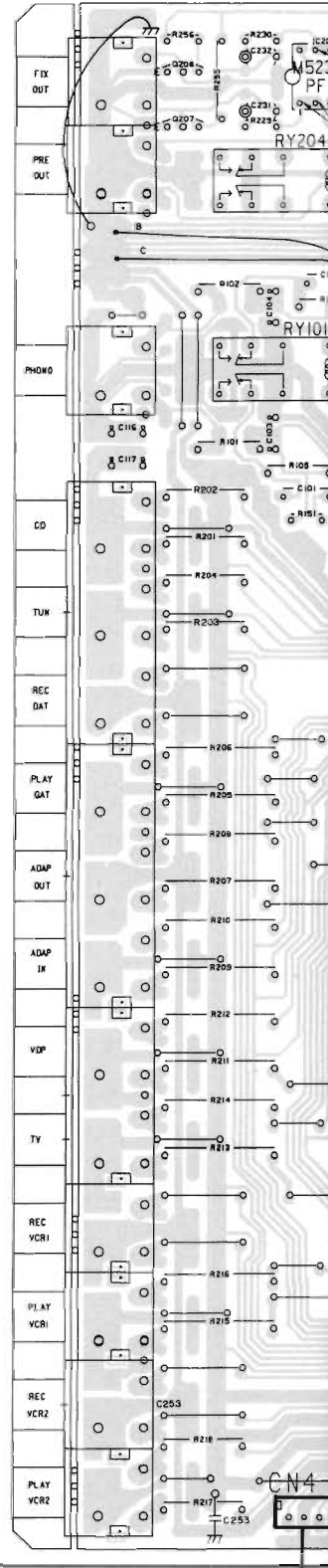
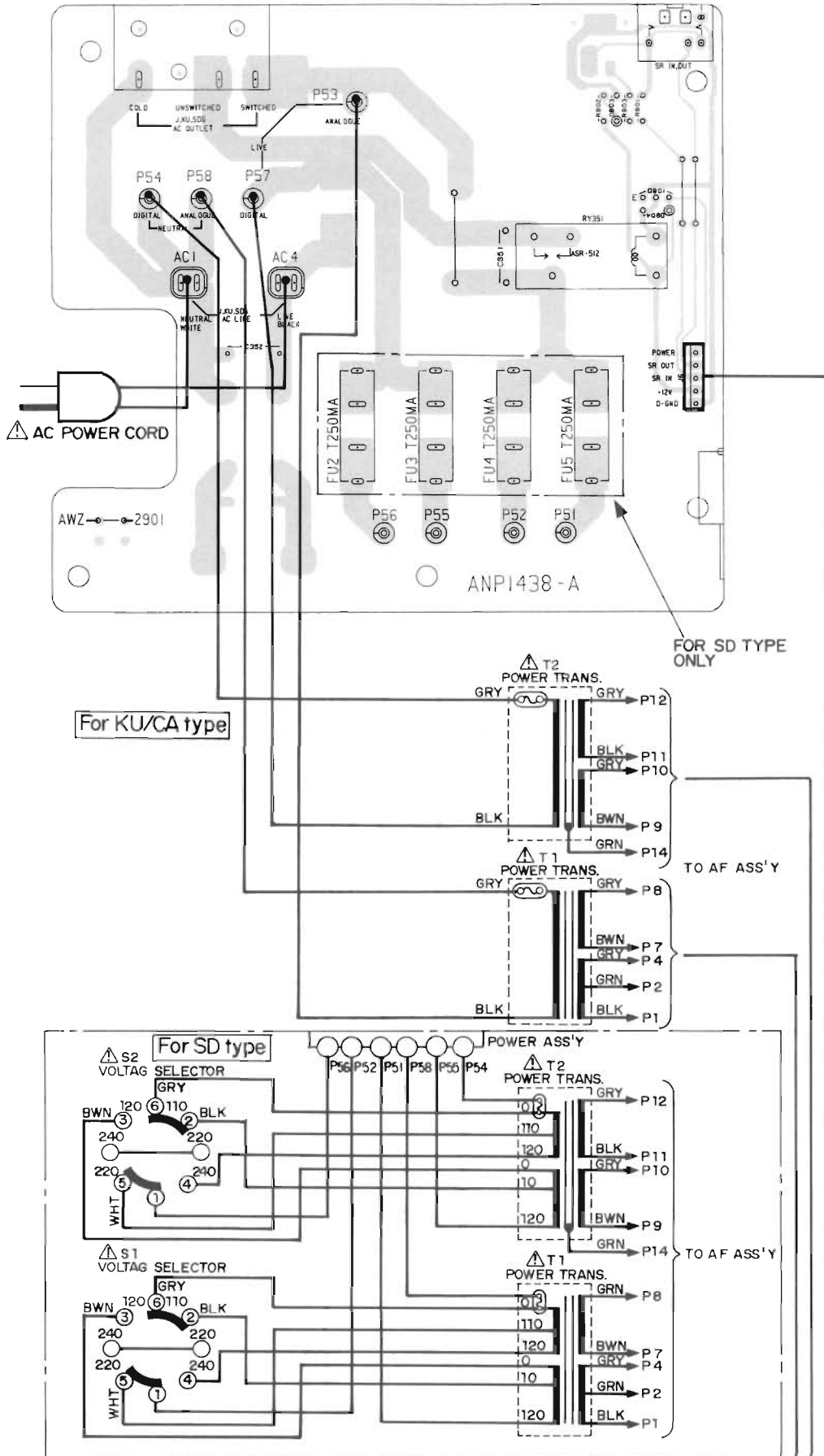

Q208
Q207

SY (AWK1301)

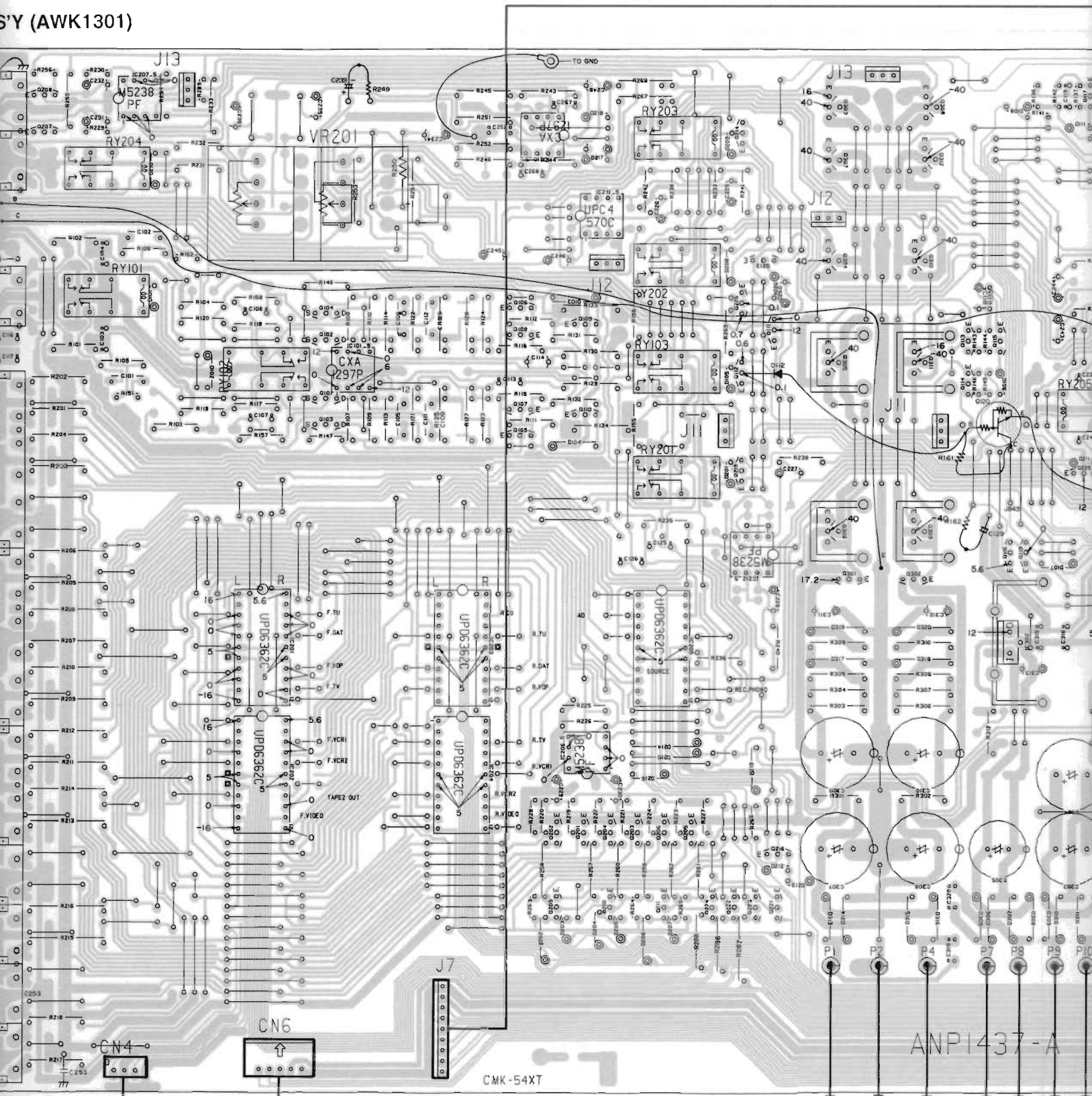

Q208
Q207

Q104
Q102 IC101
Q101
Q103
IC201
IC202

IC210 IC211

Q106 Q109
Q108
Q107 Q110
Q105
IC206

IC203
IC204

Q214
Q226 Q213
Q112 Q111
Q215
IC212
IC205
Q202 Q201 Q204 Q203 Q206 Q205 Q216
Q209 Q210 Q211 Q224 Q222 Q223 Q221

Q303 Q308
Q307 Q312
Q304 Q310
Q305 Q311
Q306 Q309
Q301 Q302

Q113 Q115
Q114 Q120
Q116 Q119
IC302

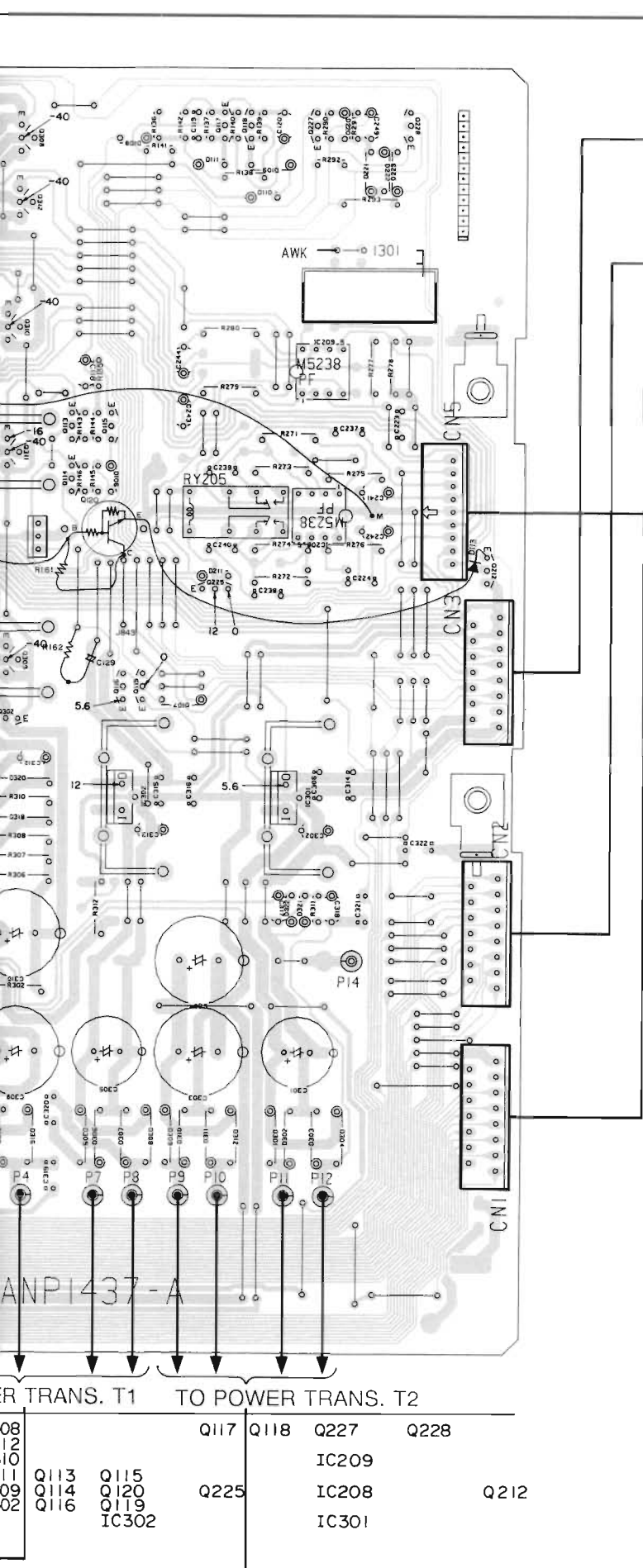

TO VIDEO ASS'Y
CN7
 (To page 25)

TO CONTROL ASS'Y
J3
 (To page 25)

TO CONTROL ASS'Y
J2
 (To page 25)

TO CONTROL ASS'Y
J1
 (To page 24)

TO CONTROL ASS'Y
J5
 (To page 25)

1. This P.C.B connection diagram is seen from the parts mount side.
2. The parts mounted on to the P.C.B can be replaced with those shown in the following correspondence table with wiring marks.

Indication of the P.C.B. pattern	Symbol of corresponding parts	Parts name
		Transistor
		Radiator type transistor
		Diode
		Resistor
		Condenser (Polar type)
		Condenser (Non-polar type)

Others

Wiring mark on the P.C.B pattern diagram	Parts list
IC	IC
S	Switch
RY	Relay
L	Coil
F	Filter
VR	Variable resistor or semi-fixed resistor

3. The condenser terminal marked with double circles (⊙) represents (-) terminal.
4. The diode terminal marked with double circles (⊙) represents the cathode side.
5. The transistor terminal marked with "E" represents an emitter.

Q113	Q115	Q117	Q118	Q227	Q228
Q114	Q120			IC209	
Q116	Q119	Q225		IC208	Q212
	IC302			IC301	

TO AF ASS'Y
J7
(To page 16)

TO AF ASS'Y
CN3
(To page 17)

TO AF ASS'Y
CN2
(To page 17)

TO AF ASS'Y
CN1
(To page 17)

TO AF ASS'Y
CN5
(To page 17)

CONTROL ASS'Y (AWZ2898)

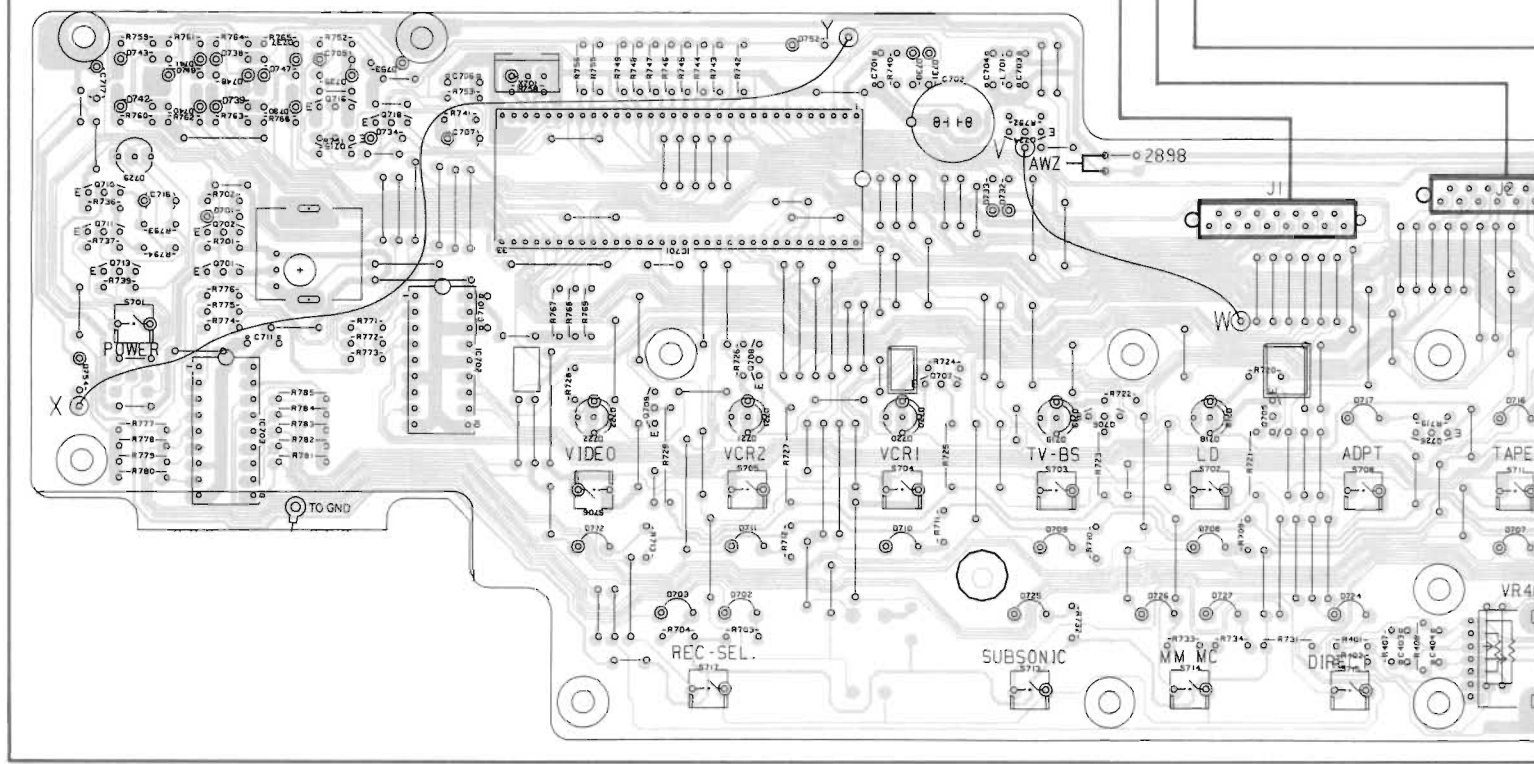

Q710	Q702	Q716	Q718	Q724					
Q711	Q701	Q715							
Q713									
	IC703	IC702	IC701	IC709	Q708	Q707	Q706	Q705	Q726

VIDEO ASS'Y (AWZ2900)

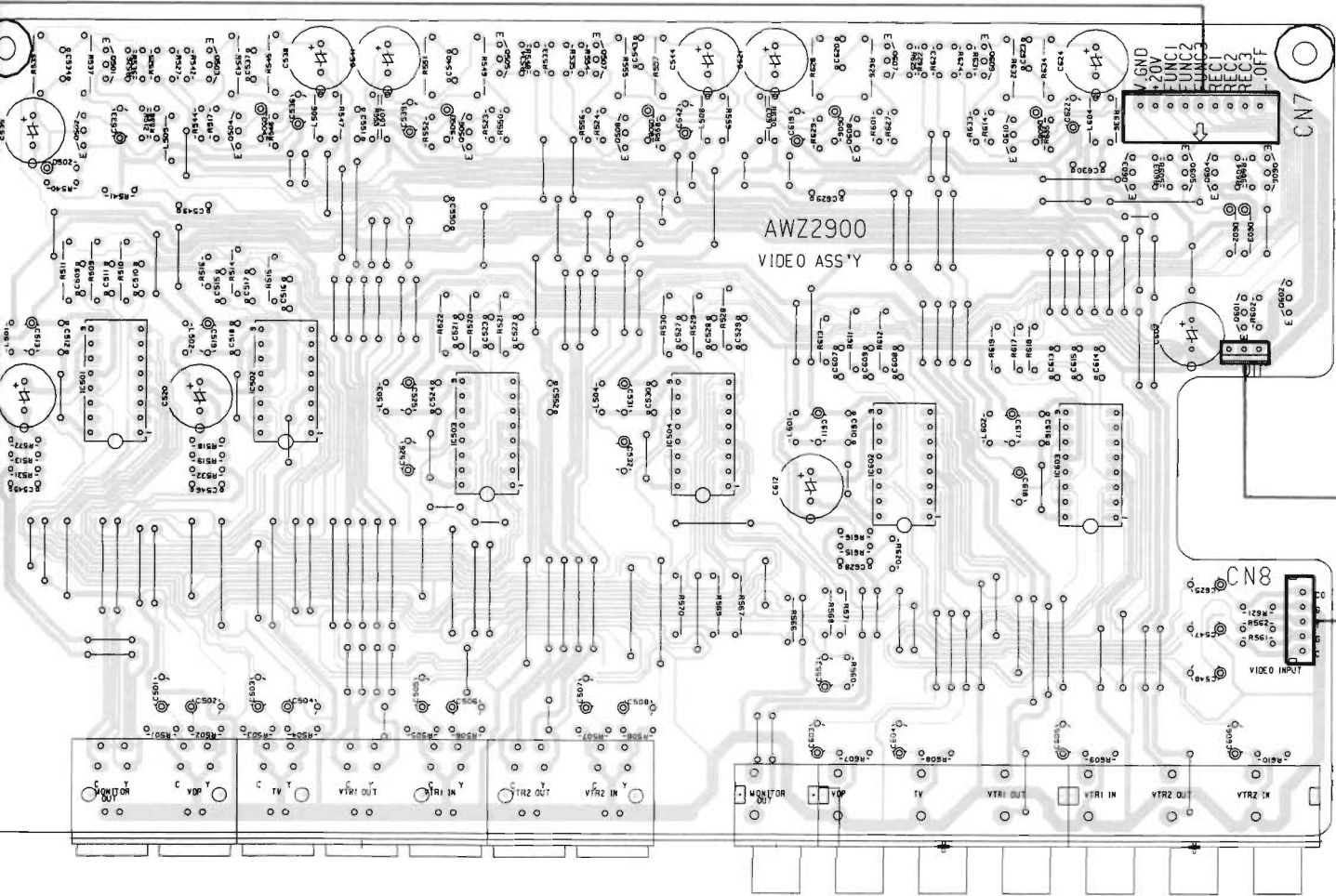

Q501
Q503
Q502
Q504

IC501
IC502

VOLUME DR

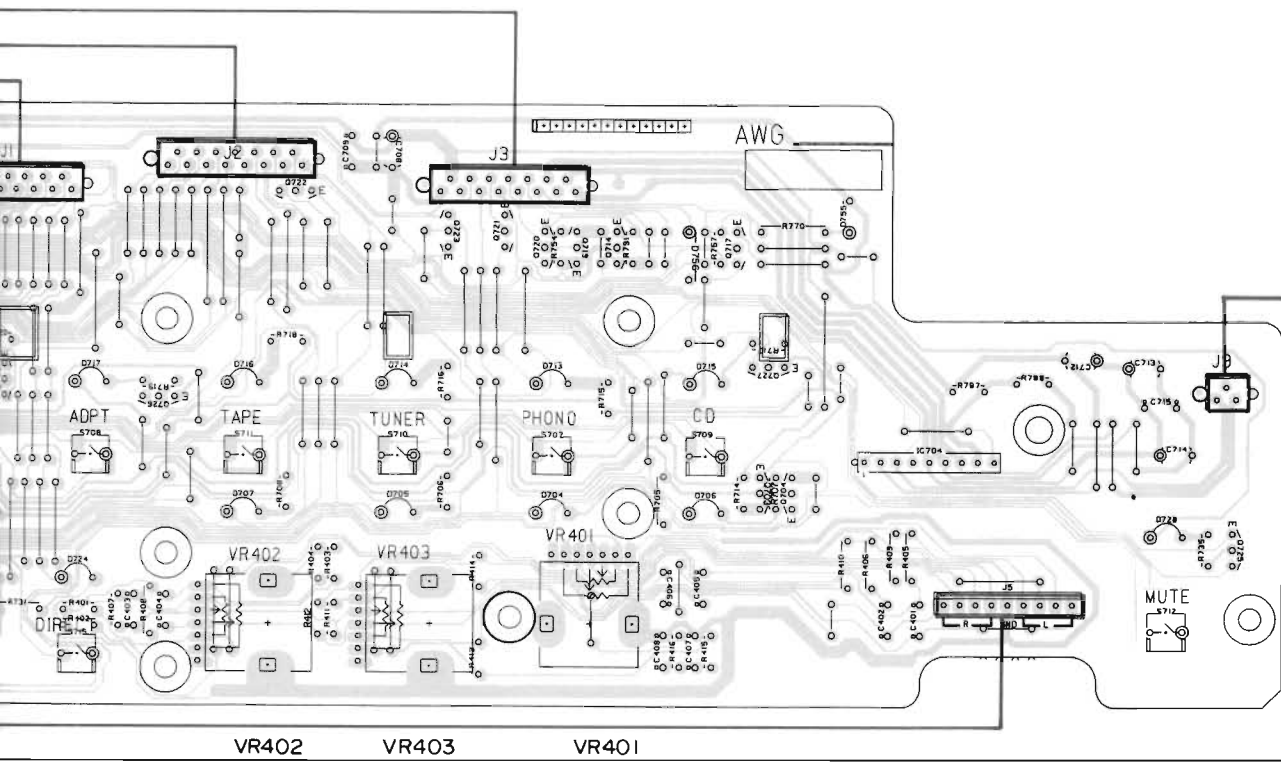

VR402 VR403 VR401

Q722 Q723 Q720 Q719 Q717
Q721 Q719 Q714 Q727 IC704
Q703 Q704

Q705 Q726

Q725

Q501 Q505 Q607
 Q503 Q507 Q609
 Q502 Q506 Q608
 Q504 Q508 Q610

Q603
 Q605
 Q604
 Q606

Q602
 Q601

TO AF ASS'Y
CN4
 (To page 16)
FRONT INPUT ASS'Y

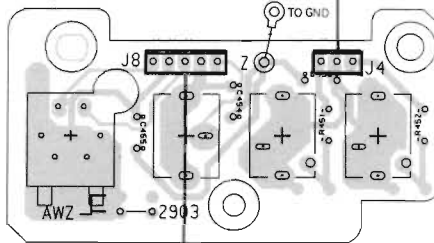

IC501 IC503 IC602
 IC502 IC504 IC603

REGULATOR ASS'Y

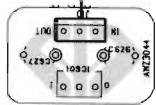

A

B

1. This P.C.B connection diagram is seen from the parts mount side.
2. The parts mounted on to the P.C.B can be replaced with those shown in the following correspondence table with wiring marks.

VOLUME DRIVE ASS'Y

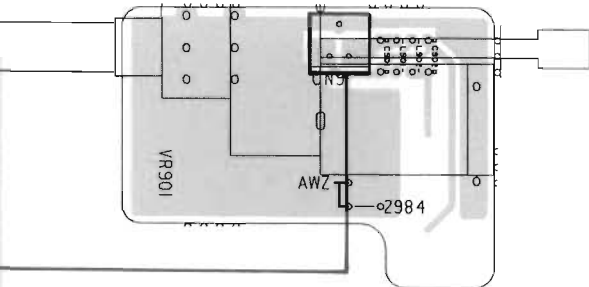

C

Indication of the P.C.B. pattern	Symbol of corresponding parts	Parts name
 Q504 E O	 or 	Transistor
 Q215	 or 	Radiator type transistor
 D203		Diode
 R237		Resistor
 C513		Condenser (Polar type)
 C518		Condenser (Non-polar type)

Others

Wiring mark on the P.C.B pattern diagram	Parts list
IC	IC
S	Switch
RY	Relay
L	Coil
F	Filter
VR	Variable resistor or semi-fixed resistor

D

3. The condenser terminal marked with double circles (⊙) represents (-) terminal.
4. The diode terminal marked with double circles (⊙) represents the cathode side.
5. The transistor terminal marked with "E" represents an emitter.

VIDEO ASS'Y AWZ2900

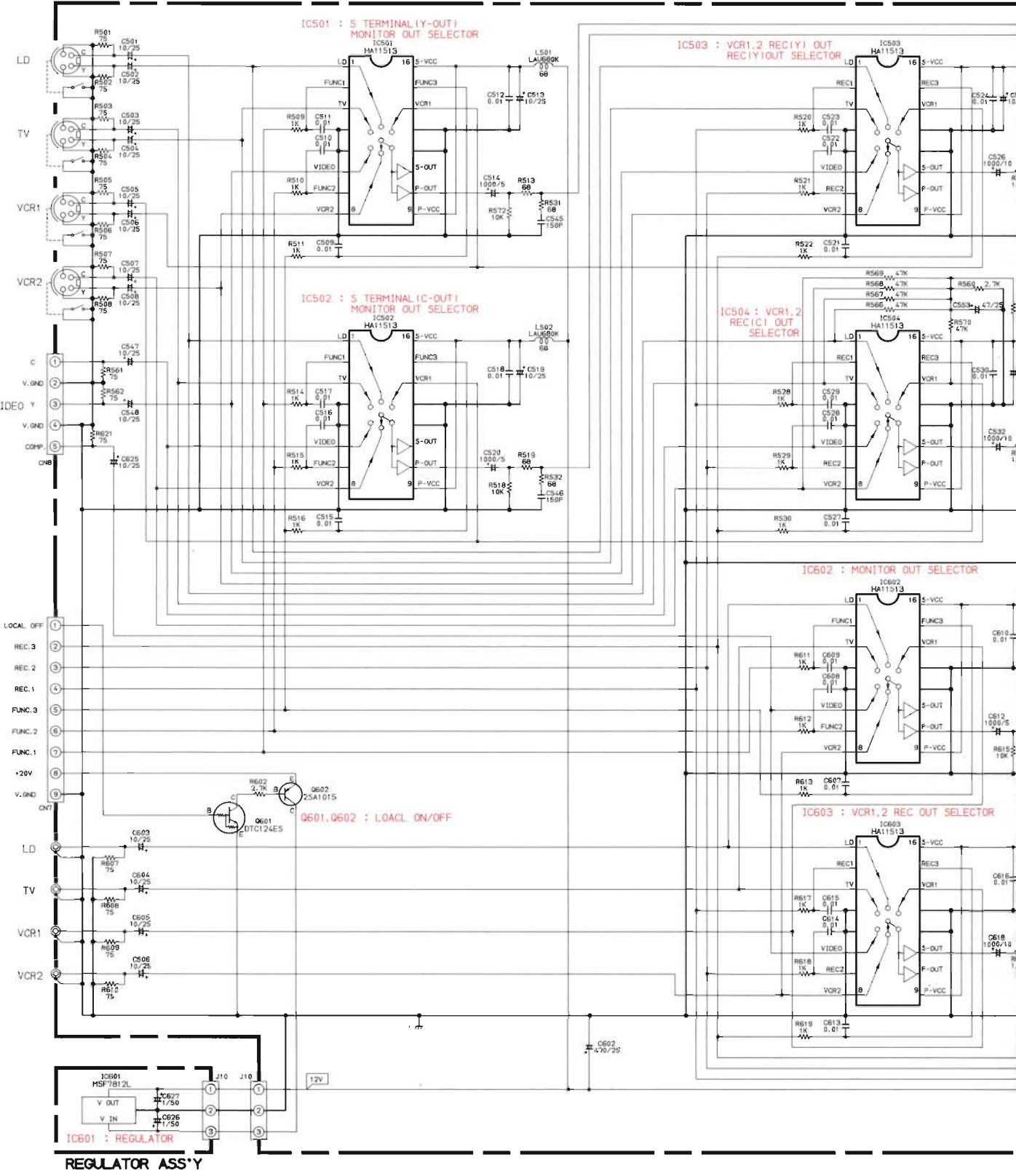

REGULATOR ASS'Y

A

B

C

D

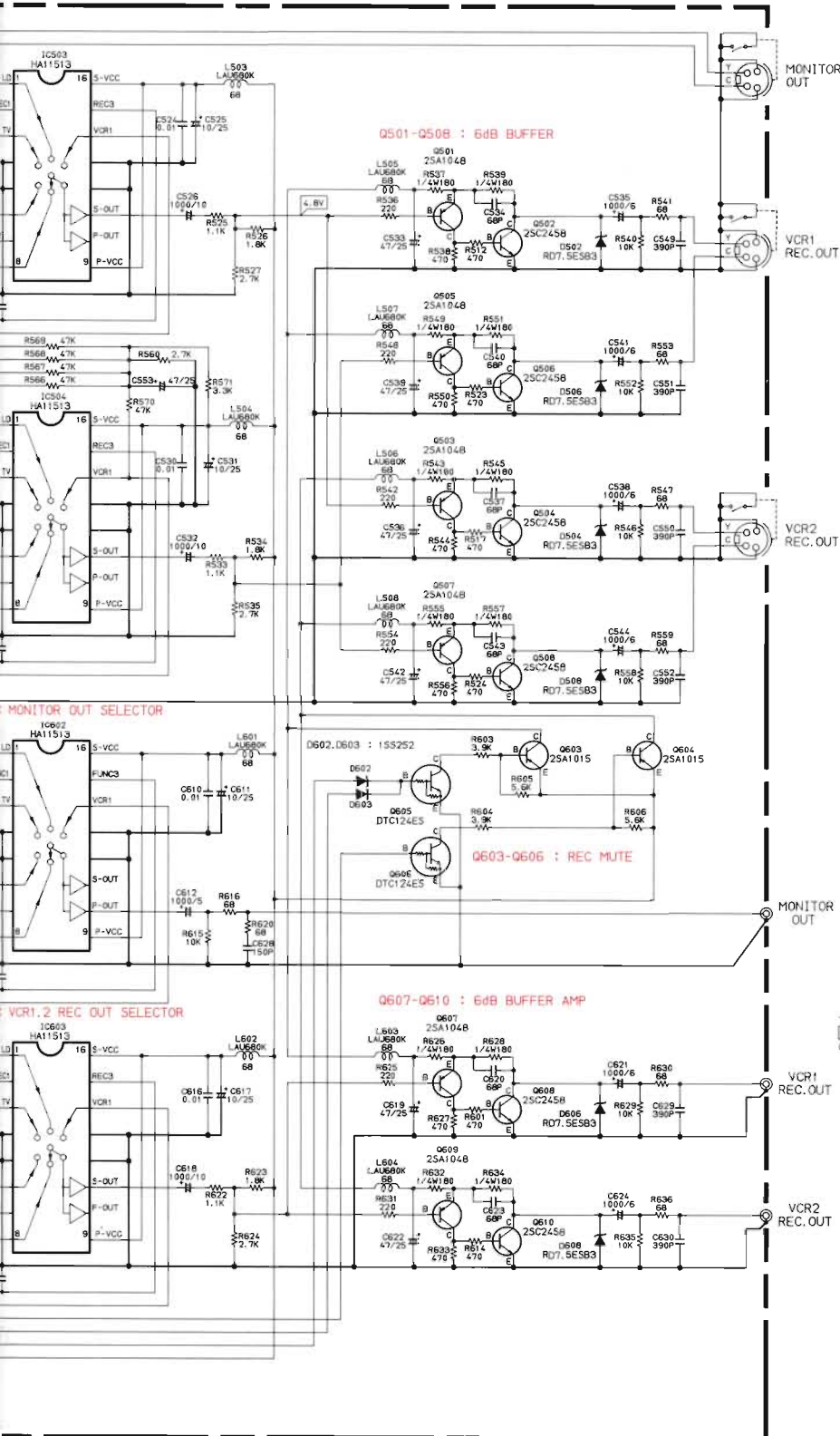

CONTROL ASS'Y AWZ2896 (2/2)

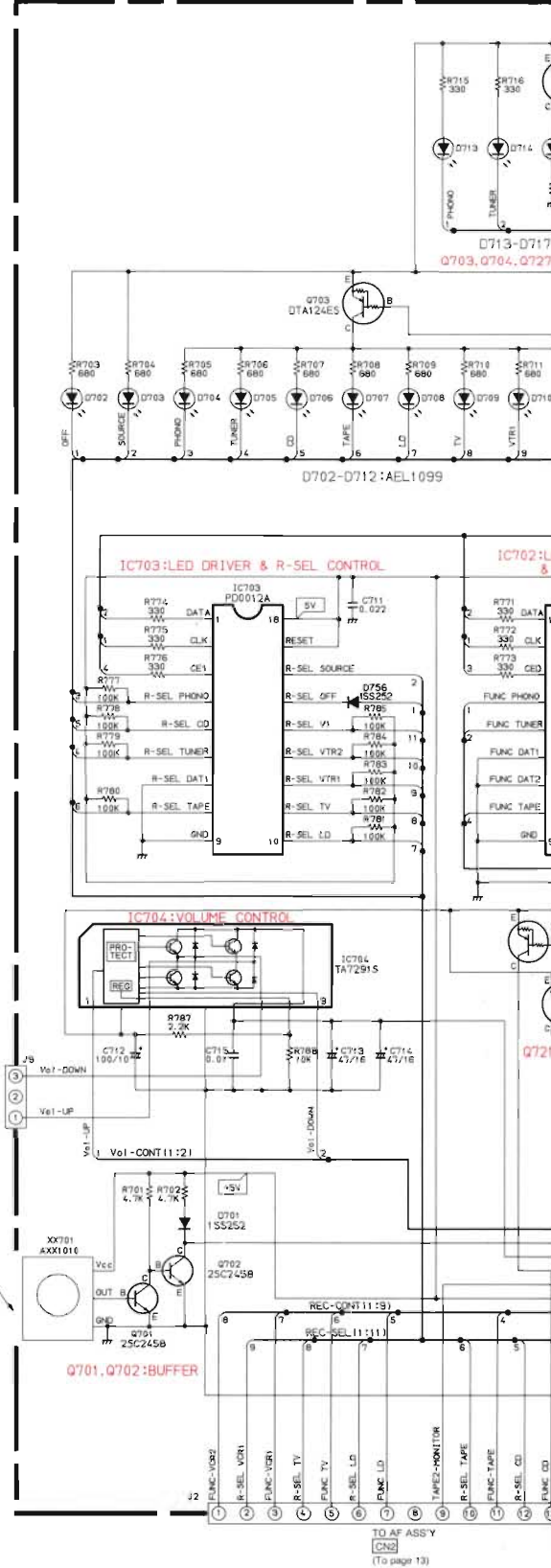

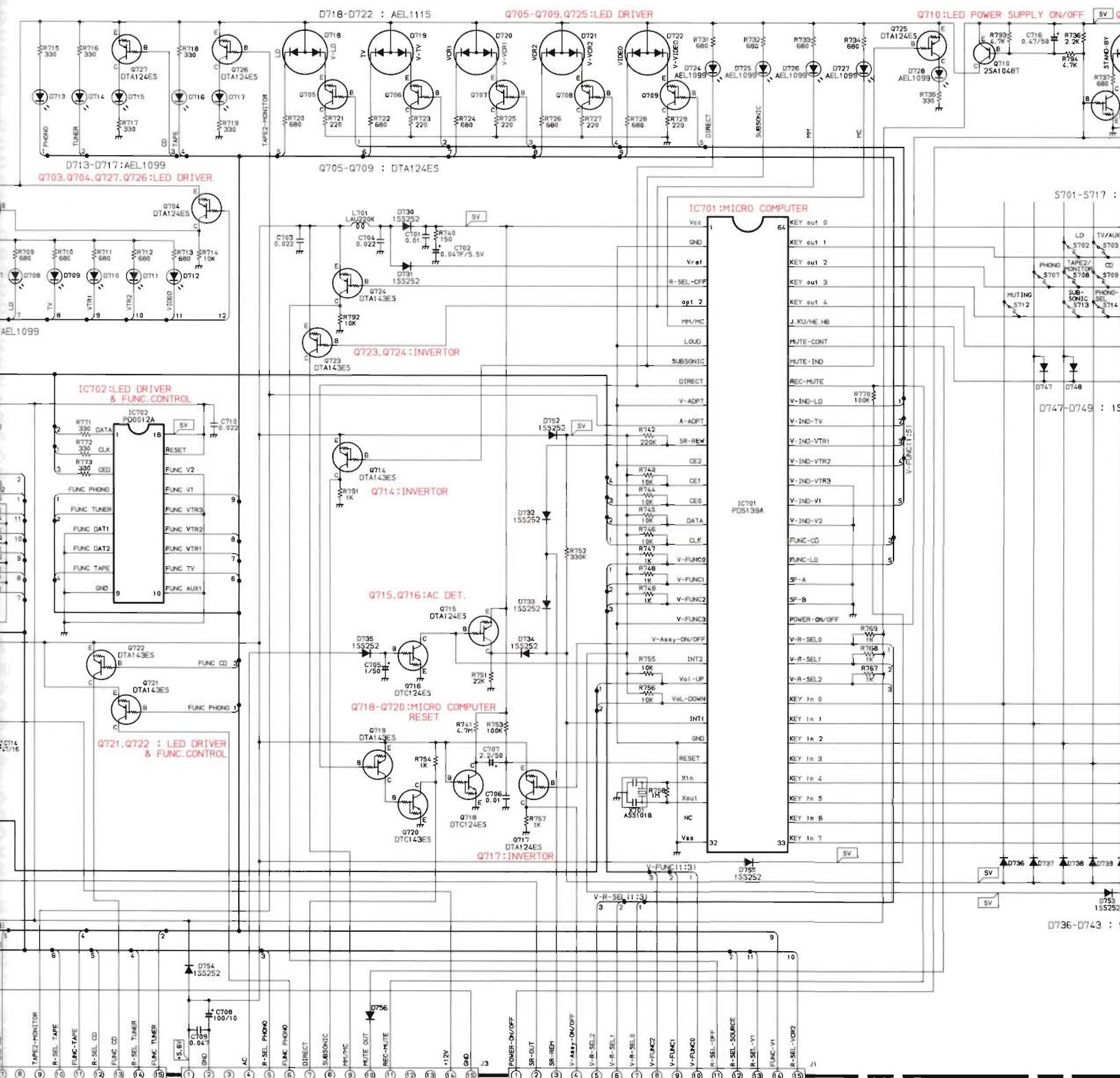

TO AF ASSY (CN3) (To page 13)

TO AF ASSY (CN1) (To page 14)

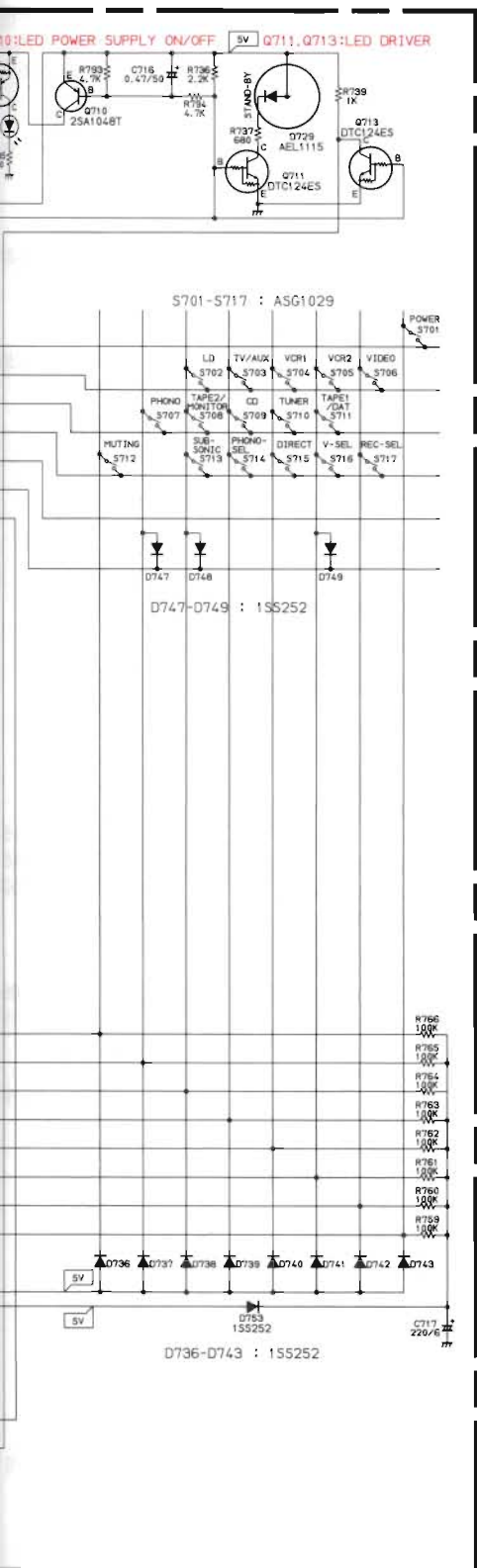

CONTROL ASS'Y AWZ2898(1/2)

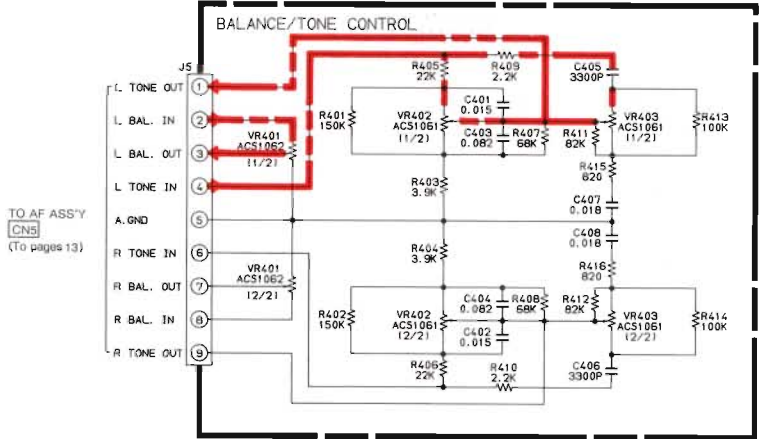

FRONT INPUT ASS'Y

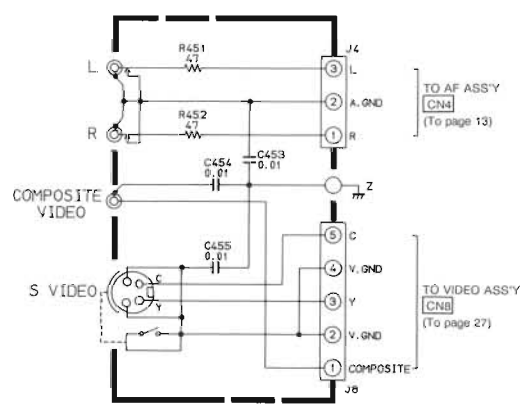

VOLUME DRIVE ASS'Y

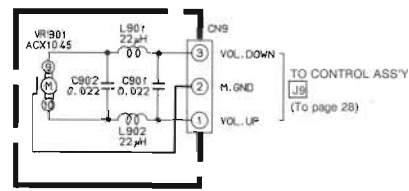

3.2 P.C.B's PARTS LIST

NOTES:

- A • Parts without part number cannot be supplied.
- Parts marked by "⊙" are not always kept in stock. Their delivery time may be longer than usual or they may be unavailable.
- The Δ mark found on some component parts indicates the importance of the safety factor of the part. Therefore, when replacing, be sure to use parts of identical designation.
- When ordering resistors, first convert resistance values into code form as shown in the following examples.

Ex. 1 When there are 2 effective digits (any digit apart from 0), such as 560 ohm and 47k ohm (tolerance is shown by J = 5%, and K = 10%).

560Ω	56 × 10 ¹	561.....	RD1/4PS	Ⓜ	Ⓜ	Ⓜ	J
47kΩ	47 × 10 ³	473.....	RD1/4PS	Ⓜ	Ⓜ	Ⓜ	J
0.5Ω	0R5.....		RN2H	Ⓜ	Ⓜ	Ⓜ	K
1Ω	010.....		RS1P	Ⓜ	Ⓜ	Ⓜ	K

Ex. 2 When there are 3 effective digits (such as in high precision metal film resistors).

5.62kΩ	562 × 10 ¹	5621.....	RN1/4SR	Ⓜ	Ⓜ	Ⓜ	F
--------	-----------------------	-----------	---------	---	---	---	---

Mark. No.	Description	Parts No.	Mark. No.	Description	Parts No.
B POWER ASS'Y			REGULATOR ASS'Y		
SEMICONDUCTORS			SEMICONDUCTORS		
Q801	TRANSISTOR	DTC143ES	IC601	REGULATOR IC	M5F7812L
D803	ZENER DIODE	RD5.1ESB	CAPACITORS		
D804	DIODE	1SS252	C626,C627	ELECTR. CAPACITOR	CEHAQ010M50
CAPACITORS			VIDEO ASS'Y (AWZ2900)		
Δ C351,C352	CKA(0.01/AC400V)	ACG1002	SEMICONDUCTORS		
RESISTORS			IC501-IC504	5CH VIDEO-SW IC	HA11513
R801-R803	CARBON FILM RESISTOR	RD1/8PMLLJJ	IC602,IC603	5CH VIDEO-SW IC	HA11513
OTHERS			Q501	TRANSISTOR	2SA1048
Δ RY351	RELAY	ASR-512	Q502	TRANSISTOR	2SC2458
	JACK(CONTROL)	AKN1006	Q503	TRANSISTOR	2SA1048
	AC OUTLET(3P)	AKP1053	Q504	TRANSISTOR	2SC2458
FRONT INPUT ASS'Y			Q505	TRANSISTOR	2SA1048
CAPACITORS			Q506	TRANSISTOR	2SC2458
C453-C455	CERAMIC CAPACITOR	CKDYF103Z50	Q507	TRANSISTOR	2SA1048
RESISTORS			Q508	TRANSISTOR	2SC2458
R451,R452	CARBON FILM RESISTOR	RD1/8PM470J	Q601	TRANSISTOR	DTC124ES
OTHERS			Q602-Q604	TRANSISTOR	2SA1515
	PIN JACK(1P)(AUDIO)	AKB1082	Q605,Q606	TRANSISTOR	DTC124ES
	PIN JACK(1P)(VIDEO)	AKB1083	Q607	TRANSISTOR	2SA1048
	SOCKET(S-VIDEO)	AKP1067	Q608	TRANSISTOR	2SC2458
VOLUME DRIVE ASS'Y			Q609	TRANSISTOR	2SA1048
CAPACITORS			Q610	TRANSISTOR	2SC2458
C901,C902	CERAMIC CAPACITOR	CKCYF223Z50	D502	ZENER DIODE	RD7.5ESB3
COILS & FILTERS			D504	ZENER DIODE	RD7.5ESB3
L901,L902	AXIAL INDUCTOR	LAU220K	D506	ZENER DIODE	RD7.5ESB3
RESISTOR			D508	ZENER DIODE	RD7.5ESB3
VR901	VOLUME CONTROL(MOTOR)	ACX1045	D602,D603	DIODE	1SS252
OTHERS			D606	ZENER DIODE	RD7.5ESB3
CN9	CONNECTOR(3P)	KPE3	D608	ZENER DIODE	RD7.5ESB3
			COILS & FILTERS		
			L501-L508	AXIAL INDUCTOR	LAU680K
			L601-L604	AXIAL INDUCTOR	LAU680K

Mark. No.	Description	Parts No.	Mark. No.	Description	Parts No.
CAPACITORS			R551	CARBON FILM RESISTOR	RD1/4PMUCCJ
C501-C508	ELECTR. CAPACITOR	CEAS100M25	R555	CARBON FILM RESISTOR	RD1/4PMCCNJ
C509-C512	CERAMIC CAPACITOR	CKDYF103Z50	R557	CARBON FILM RESISTOR	RD1/4PMCCNJ
C513	ELECTR. CAPACITOR	CEAS100M25	R626	CARBON FILM RESISTOR	RD1/4PMCCNJ
C514	ELECTR. CAPACITOR	CEAS102M6	R628	CARBON FILM RESISTOR	RD1/4PMCCNJ
C515-C518	CERAMIC CAPACITOR	CKDYF103Z50	R632	CARBON FILM RESISTOR	RD1/4PMCCNJ
C519	ELECTR. CAPACITOR	CEAS100M25	R634	CARBON FILM RESISTOR	RD1/4PMCCNJ
C520	ELECTR. CAPACITOR	CEAS102M6	OTHER RESISTORS		
C521-C524	CERAMIC CAPACITOR	CKDYF103Z50	OTHERS		
C525	ELECTR. CAPACITOR	CEAS100M25	CN7	CONNECTOR(9P)	KPC9
C526	ELECTR. CAPACITOR	CEAS101M10		PIN JACK(3P)(VCR1 IN· VCR2 IN·VCR2 OUT)	AKB1143
C527-C530	CERAMIC CAPACITOR	CKDYF103Z50		PIN JACK(3P)(LD IN· TV/AUX IN·VCR1 OUT)	AKB1150
C531	ELECTR. CAPACITOR	CEAS100M25		PIN JACK(1P) (MONITOR OUT)	AKB1152
C532	ELECTR. CAPACITOR	CEAS101M10		SOCKET(4Px2, DIN) (MONITOR OUT·LD IN)	AKP1064
C533	ELECTR. CAPACITOR	CEAS470M25		SOCKET(4Px3, DIN) (TV/AUX·VCR1 IN· VCR1 OUT)	AKP1065
C534	CERAMIC CAPACITOR	CCDSL680J50	CONTROL ASS'Y (AWZ2898)		
C535	ELECTR. CAPACITOR	CEAS102M6	SEMICONDUCTORS		
C536	ELECTR. CAPACITOR	CEAS470M25	IC701	AMP CONTROL MICOM	PD5139A
C537	CERAMIC CAPACITOR	CCDSL680J50	IC702,IC703	OUTPUT EXPANDER IC	PD0012A
C538	ELECTR. CAPACITOR	CEAS102M6	IC704	MECHANISM DRIVER IC	TA7291S
C539	ELECTR. CAPACITOR	CEAS470M25	Q701,Q702	TRANSISTOR	2SC2458
C540	CERAMIC CAPACITOR	CCDSL680J50	Q703-Q709	TRANSISTOR	DTA124ES
C541	ELECTR. CAPACITOR	CEAS102M6	Q710	TRANSISTOR	2SA1048
C542	ELECTR. CAPACITOR	CEAS470M25	Q711	TRANSISTOR	DTC124ES
C543	CERAMIC CAPACITOR	CCDSL680J50	Q713	TRANSISTOR	DTC124ES
C544	ELECTR. CAPACITOR	CEAS102M6	Q714	TRANSISTOR	DTA143ES
C545,C546	CERAMIC CAPACITOR	CCDSL151J50	Q715	TRANSISTOR	DTA124ES
C547,C548	ELECTR. CAPACITOR	CEAS100M25	Q716	TRANSISTOR	DTC124ES
C549-C552	CERAMIC CAPACITOR	CKDYB391K50	Q717	TRANSISTOR	DTA124ES
C553	ELECTR. CAPACITOR	CEAS470M25	Q718	TRANSISTOR	DTC124ES
C602	ELECTR. CAPACITOR	CEAS471M25	Q719	TRANSISTOR	DTA143ES
C603-C606	ELECTR. CAPACITOR	CEAS100M25	Q720	TRANSISTOR	DTC143ES
C607-C610	CERAMIC CAPACITOR	CKDYF103Z50	Q721-Q724	TRANSISTOR	DTA143ES
C611	ELECTR. CAPACITOR	CEAS100M25	Q725-Q727	TRANSISTOR	DTA124ES
C612	ELECTR. CAPACITOR	CEAS102M6	D701	DIODE	1SS252
C613-C616	CERAMIC CAPACITOR	CKDYF103Z50	D702-D717	LED(RED)	AEL1099
C617	ELECTR. CAPACITOR	CEAS100M25	D718-D722	LED(RED,AMBER)	AEL1115
C618	ELECTR. CAPACITOR	CEAS101M10	D724-D728	LED(RED)	AEL1099
C619	ELECTR. CAPACITOR	CEAS470M25	D729	LED(RED,AMBER)	AEL1115
C620	CERAMIC CAPACITOR	CCDSL680J50	D730-D743	DIODE	1SS252
C621	ELECTR. CAPACITOR	CEAS102M6	D747-D749	DIODE	1SS252
C622	ELECTR. CAPACITOR	CEAS470M25	D752-D756	DIODE	1SS252
C623	CERAMIC CAPACITOR	CCDSL680J50	COIL & FILTER		
C624	ELECTR. CAPACITOR	CEAS102M6	L701	AXIAL INDUCTOR	LAU220K
C625	ELECTR. CAPACITOR	CEAS100M25			
C628	CERAMIC CAPACITOR	CCDSL151J50			
C629,C630	CERAMIC CAPACITOR	CKDYB391K50			
RESISTORS					
R537	CARBON FILM RESISTOR	RD1/4PMUCCJ			
R539	CARBON FILM RESISTOR	RD1/4PMUCCJ			
R543	CARBON FILM RESISTOR	RD1/4PMUCCJ			
R545	CARBON FILM RESISTOR	RD1/4PMUCCJ			
R549	CARBON FILM RESISTOR	RD1/4PMUCCJ			

Mark.	No.	Description	Parts No.	Mark.	No.	Description	Parts No.
CAPACITORS							
A	C401,C402	AUDIO FILM CAPACITOR	CFTXA153J50	Q216	TRANSISTOR	DTA143ES	
	C403,C404	AUDIO FILM CAPACITOR	GFTXA823J50	Q221	TRANSISTOR	DTA143ES	
	C405,C406	MYLOR FILM CAPACITOR	CQMA332J50	Q222-Q224	TRANSISTOR	2SA1048	
	C407,C408	AUDIO FILM CAPACITOR	CFTXA183J50	Q225	TRANSISTOR	DTC143ES	
	C701	CERAMIC CAPACITOR	CKCYF103Z50	Q226	TRANSISTOR	2SC2458	
	C702	CEA(47000/5.5V)	ACH1037	Q227	TRANSISTOR	DTA143ES	
	C703,C704	CERAMIC CAPACITOR	CKDYF223Z50	Q228	TRANSISTOR	2SC2458	
	C705	ELECTR. CAPACITOR	CEJA010M50	Q301	TRANSISTOR	2SC1845	
	C706	CERAMIC CAPACITOR	CKCYF103Z50	Q302	TRANSISTOR	2SA992	
	C707	ELECTR. CAPACITOR	CEJA2R2M50	Q303	TRANSISTOR	2SC3298	
C708	ELECTR. CAPACITOR	CEJA101M10	Q304	TRANSISTOR	2SC2705		
C709	CERAMIC CAPACITOR	CKCYF473Z50	Q305-Q307	TRANSISTOR	2SC3298		
C710,C711	CERAMIC CAPACITOR	CKDYF223Z50	Q308,Q309	TRANSISTOR	2SA1306		
C712	ELECTR. CAPACITOR	CEJA101M10	Q310	TRANSISTOR	2SA1145		
C713,C714	ELECTR. CAPACITOR	CEJA470M16	Q311,Q312	TRANSISTOR	2SA1306		
C715	CERAMIC CAPACITOR	CKCYF103Z50	D101,D102	DIODE	1SS252		
C716	ELECTR. CAPACITOR	CEJAR47M50	D103,D104	ZENER DIODE	RD12ESB1		
C717	ELECTR. CAPACITOR	CEJA221M6	D105-D113	DIODE	1SS252		
RESISTORS				D201-D216	DIODE	1SS252	
VR401	VARIABLE	ACS1062	D217,D218	ZENER DIODE	RD12ESB3		
VR402,VR403	VARIABLE(250Kx2)	ACS1061	D219-D223	DIODE	1SS252		
OTHER RESISTORS		RD1/8PM.	D224	ZENER DIODE	RD10ESB2		
SWITCHES				D301-D312	DIODE	S5566	
S701-S717	SWITCH	ASG1029	D313-D316	DIODE	10DF2FD		
OTHERS				D317,D318	ZENER DIODE	RD27FB	
X701	CERAMIC RESONATOR	ASS1018	D319,D320	ZENER DIODE	RD18FB2		
	REMOTE RECEIVER UNIT	AXX1010	D321,D322	DIODE	1SS252		
AF ASS'Y (AWK1301)				CAPACITORS			
SEMICONDUCTORS				C101,C102	PP CAPACITOR(0.01/50V)	ACE1018	
IC101	OP-AMP IC	CXA1297P	C103,C104	PP CAPACITOR(68pF)	ACE1024		
IC201-IC205	E-SW IC	UPD6362C	C105,C106	PP CAPACITOR(0.01/50V)	ACE1018		
IC206-IC209	OP AMP IC	M5238PF	C107,C108	ELECTR. CAPACITOR	CEXANP101M25		
IC210	OP AMP IC	CXA1297P	C109,C110	PP CAPACITOR(0.051/50V)	ACE1049		
IC211	IC	UPC4570C	C111,C112	PP CAPACITOR(0.015/50V)	ACE1030		
IC212	OP AMP IC	M5238PF	C113,C114	ELECTR. CAPACITOR	CEXANP3R3M50		
IC301	REGULATOR IC	NJM78M56FA	C116,C117	CERAMIC CAPACITOR	CKDYB103K50		
IC302	REGULATOR IC	UPC7812H	C118	ELECTR. CAPACITOR	CEAS100M25		
Q101-Q104	N-FET	2SK369	C119	CERAMIC CAPACITOR	CKDYF103Z50		
Q105-Q108	TRANSISTOR	2SC1845	C120	ELECTR. CAPACITOR	CEAS101M16		
Q109	TRANSISTOR	2SA992	C125,C126	POLYESTER CAPACITOR	CQMXA472J100		
Q110	TRANSISTOR	2SC1845	C129	ELECTR. CAPACITOR	CEANP010M50		
Q111	TRANSISTOR	DTC143ES	C223,C224	CERAMIC CAPACITOR	CCCSL680K500		
Q112	TRANSISTOR	2SC2458	C225,C226	ELECTR. CAPACITOR	CEXA4R7M50		
Q113	TRANSISTOR	2SA992	C227,C228	ELECTR. CAPACITOR	CEYA100M50		
Q114	TRANSISTOR	2SC1845	C229,C230	ELECTR. CAPACITOR	CEAS101M16		
Q115	TRANSISTOR	DTC143ES	C231,C232	ELECTR. CAPACITOR	CEYA100M50		
Q116	TRANSISTOR	DTA143ES	C233,C234	ELECTR. CAPACITOR	CEXA4R7M50		
Q117	TRANSISTOR	2SA1048	C235,C236	ELECTR. CAPACITOR	CEXA101M25		
Q118	TRANSISTOR	2SC2458	C237,C238	ELECTR. CAPACITOR	CEAS010M50		
Q119	TRANSISTOR	DTC124ES	C239,C240	AUDIO FILM CAPACITOR	CFTXA823J50		
Q120	TRANSISTOR	DTC143ES	C241,C242	ELECTR. CAPACITOR	CEAS100M50		
Q201-Q208	TRANSISTOR	2SC2878	C243,C244	ELECTR. CAPACITOR	CEAS101M16		
Q209-Q212	TRANSISTOR	DTA143ES	C245,C246	ELECTR. CAPACITOR	CEXA101M25		
Q213-Q215	TRANSISTOR	DTC143ES					

Mark. No.	Description	Parts No.	Mark. No.	Description	Parts No.
C247,C248	ELECTR. CAPACITOR	CEYA470M25		SCREW	ABA1027
C249	ELECTR. CAPACITOR	CEAS101M16		PIN JACK(6P)(VCR1·VCR2)	AKB1129
C250	ELECTR. CAPACITOR	CEAS010M50		PIN JACK(4P)(PRE OUT)	AKB1147
C252	CERAMIC CAPACITOR	CKCYB102K50		PIN JACK(6P)(TAPE1/DAT·	AKB1148
C253	CERAMIC CAPACITOR	CKDYF103Z50		TAPE2/MONITOR, LD·	
				TV/AUX·VCR1)	
C267,C268	CERAMIC CAPACITOR	CCCSL330J50		PIN JACK(6P)(CD·TUNER·	AKB1149
C301	ELECTR. CAPACITOR	CEAS222M25		TAPE1/DAT)	
C302	ELECTR. CAPACITOR	CEHAQ010M50			
C303,C304	ELECTR. CAPACITOR	CEAS222M35		PIN JACK(2P)(PHONO)	AKB1151
C305	ELECTR. CAPACITOR	CEAS102M25			
C306	CERAMIC CAPACITOR	CKDYF103Z50			
C307-C310	ELECTR. CAPACITOR	CEYA102M50			
C311,C312	ELECTR. CAPACITOR	CEYA101M25			
C313	ELECTR. CAPACITOR	CEHAQ010M50			
C314	ELECTR. CAPACITOR	CEAS221M16			
C315	ELECTR. CAPACITOR	CEHAQ010M50			
C316	ELECTR. CAPACITOR	CEAS221M16			
C317	ELECTR. CAPACITOR	CEAS100M50			
C318	ELECTR. CAPACITOR	CEAS220M50			
C319-C321	CKA(0.01/AC250V)	ACG1005			
C322	CERAMIC CAPACITOR	CKCYF103Z50			

RESISTORS

VR201	VARIABLE	ACW1008
R101-R120	CARBON FILM RESISTOR	RDR1/4PM111J
R121,R122	CARBON FILM RESISTOR	RD1/4PM111J
R123-R130	CARBON FILM RESISTOR	RDR1/2PM111J
R131,R132	CARBON FILM RESISTOR	RDR1/4PM111J
R133,R134	CARBON FILM RESISTOR	RDR1/2PM111J
R155-R158	CARBON FILM RESISTOR	RDR1/4PM111J
R201-R218	CARBON FILM RESISTOR	RDR1/4PM111J
R225,R226	CARBON FILM RESISTOR	RDR1/4PM111J
R229,R230	CARBON FILM RESISTOR	RDR1/6PM111J
R231,R232	CARBON FILM RESISTOR	RDR1/4PM111J
R233,R234	CARBON FILM RESISTOR	RDR1/6PM111J
R235-R242	CARBON FILM RESISTOR	RDR1/4PM111J
R243-R246	CARBON FILM RESISTOR	RDR1/2PM111J
R249,R250	CARBON FILM RESISTOR	RDR1/4PM101J
R251-R254	CARBON FILM RESISTOR	RDR1/2PM111J
R267,R268	CARBON FILM RESISTOR	RDR1/2PM111J
R269	CARBON FILM RESISTOR	RD1/4PM102J
R271-R280	CARBON FILM RESISTOR	RDR1/4PM111J
R301,R302	FUSIBLE RESISTOR	RFA1/4PS270J
R303-R310	CARBON FILM RESISTOR	RDR1/2PM111J
R312	CARBON FILM RESISTOR	RD1/4PM100J
OTHER RESISTORS		RD1/8PM111J

OTHERS

CN1-CN3	CONNECTOR(15P)	KPE15
CN5	CONNECTOR(9P)	KPC9
CN6	CONNECTOR(5P)	KPC5
RY101-RY103	RELAY	ASR1018
RY201-RY205	RELAY	ASR1018

3.3 REMOTE CONTROL UNIT (AXD1171)

EXPLODED VIEWS AND PARTS LIST

NOTES:

- Parts without part number cannot be supplied.
- The Δ mark found on some component parts indicates the importance of the safety factor of the part. Therefore, when replacing, be sure to use parts of identical designation.
- Parts marked by "●" are not always kept in stock. Their delivery time may be longer than usual or they may be unavailable.

Parts list of remote control unit

Mark	No.	Description	Parts No.
	1	Case (A)	AZH1033
	2	Case (B)	AZH1034
	3	Case (C)	AZH1035
	4	Filter	AZN1400
	5	Name plate	
	6	Rubber sheet	AZA1275
	7	Screw	AZB1124
	8	Label	
	9	Knob	AZS1042
	10	Electrode spring	AZB1274
	11	Electrode spring	AZB1275
	12	Electrode spring	AZB1276
	13	Electrode spring	AZB1277
	14	Leg	AZN1401
	15	Template	

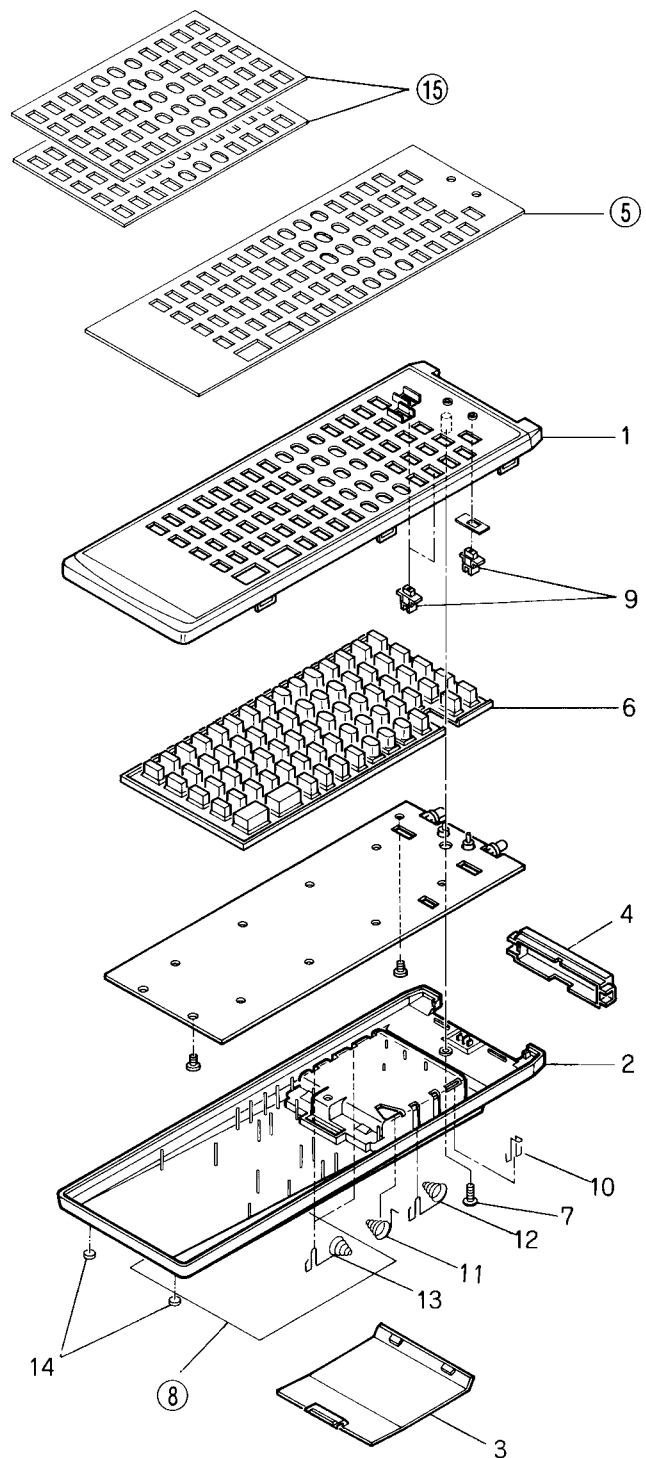

ELECTRICAL PARTS LIST

NOTES:

- Parts without part number cannot be supplied.
- Parts marked by "⊙" are not always kept in stock. Their delivery time may be longer than usual or they may be unavailable.
- The Δ mark found on some component parts indicates the importance of the safety factor of the part. Therefore, when replacing, be sure to use parts of identical designation.
- When ordering resistors, first convert resistance values into code form as shown in the following examples.

Ex. 1 When there are 2 effective digits (any digit apart from 0), such as 560 ohm and 47k ohm (tolerance is shown by J = 5%, and K = 10%).

560Ω	56 × 10 ¹	561.....	RD1/4PS	Ⓜ	Ⓜ	Ⓜ	J
47kΩ	47 × 10 ³	473.....	RD1/4PS	Ⓜ	Ⓜ	Ⓜ	J
0.5Ω	0R5.....		RN2H	Ⓜ	Ⓜ	Ⓜ	K
1Ω	010.....		RSIP	Ⓜ	Ⓜ	Ⓜ	K

Ex. 2 When there are 3 effective digits (such as in high precision metal film resistors).

5.62kΩ	562 × 10 ¹	562I.....	RN1/4SR	Ⓜ	Ⓜ	Ⓜ	F
--------	-----------------------	-----------	---------	---	---	---	---

SEMICONDUCTORS

<u>Mark</u>	<u>Symbol & Description</u>	<u>Parts No.</u>
	IC01	PD5149A
	IC02	AZC1045
	IC03	AZC1046
	IC04	AZC1047
	IC05	AZC1048
	Q01, Q02	AZC1050
	Q03, Q04	AZC1051
	Q05	AZC1052
	D01, D02, D07-D15	AZC1233
	D03-D06	AZC1049
	PHD01	AZC1055
	LED01, LED02	AZC1054
	IED01, IED02	AZC1053

RESISTORS

<u>Mark</u>	<u>Symbol & Description</u>	<u>Parts No.</u>
	R01 (32K)	AZC1064
	R02 (4.7K)	AZC1065
	R03, R08 (33K)	AZC1066
	R04 (560K)	AZC1256
	R05, R17 (10K)	AZC1068
	R06 (82K)	AZC1069
	R09 (6.8K)	AZC1070
	R10 (36K)	AZC1071
	R12 (1M)	AZC1072
	R7, R11, R30-R38 (100K)	AZC1073
	R19-R21 (2.2K)	AZC1074
	R13, R16 (680K)	AZC1075
	R15 (10K)	AZC1076
	R18, R22-R29 (47K)	AZC1077
	R14 (3.9Ω)	AZC1078

SWITCHES

<u>Mark</u>	<u>Symbol & Description</u>	<u>Parts No.</u>
	S01, S02 Slide switch	AZC1079
	S04 Tact switch	AZC1081
	S05 Slide switch	AZC1080

OTHERS

<u>Mark</u>	<u>Symbol & Description</u>	<u>Parts No.</u>
	X01 Resonator	AZC1057

CAPACITORS

<u>Mark</u>	<u>Symbol & Description</u>	<u>Parts No.</u>
	C01 (220pF)	AZC1058
	C02 (33pF)	AZC1059
	C05, C06 (20pF)	AZC1060
	C08 (0.01μF)	AZC1061
	C03, C04 (0.001μF)	AZC1062
	C07 (4.7μF)	AZC1252
	C10 (100μF)	AZC1251
	C09 (1000μF)	AZC1255
	C11 (0.01μF)	AZC1063

SCHEMATIC DIAGRAM

NOTE:

- ⏏ : Indicates a chip resistor
- ⏏ : Indicates a chip capacitor
- ⏏ : Indicates a chip transistor
- ⏏ : Indicates a chip diode.

1. RESISTORS:
Indicated in Ω, 1/8, 1/4W
K; kΩ, M; MΩ, (F); ± 1%
tolerance.
2. CAPACITORS:
Indicated in capacity (μF)
Indication without voltage

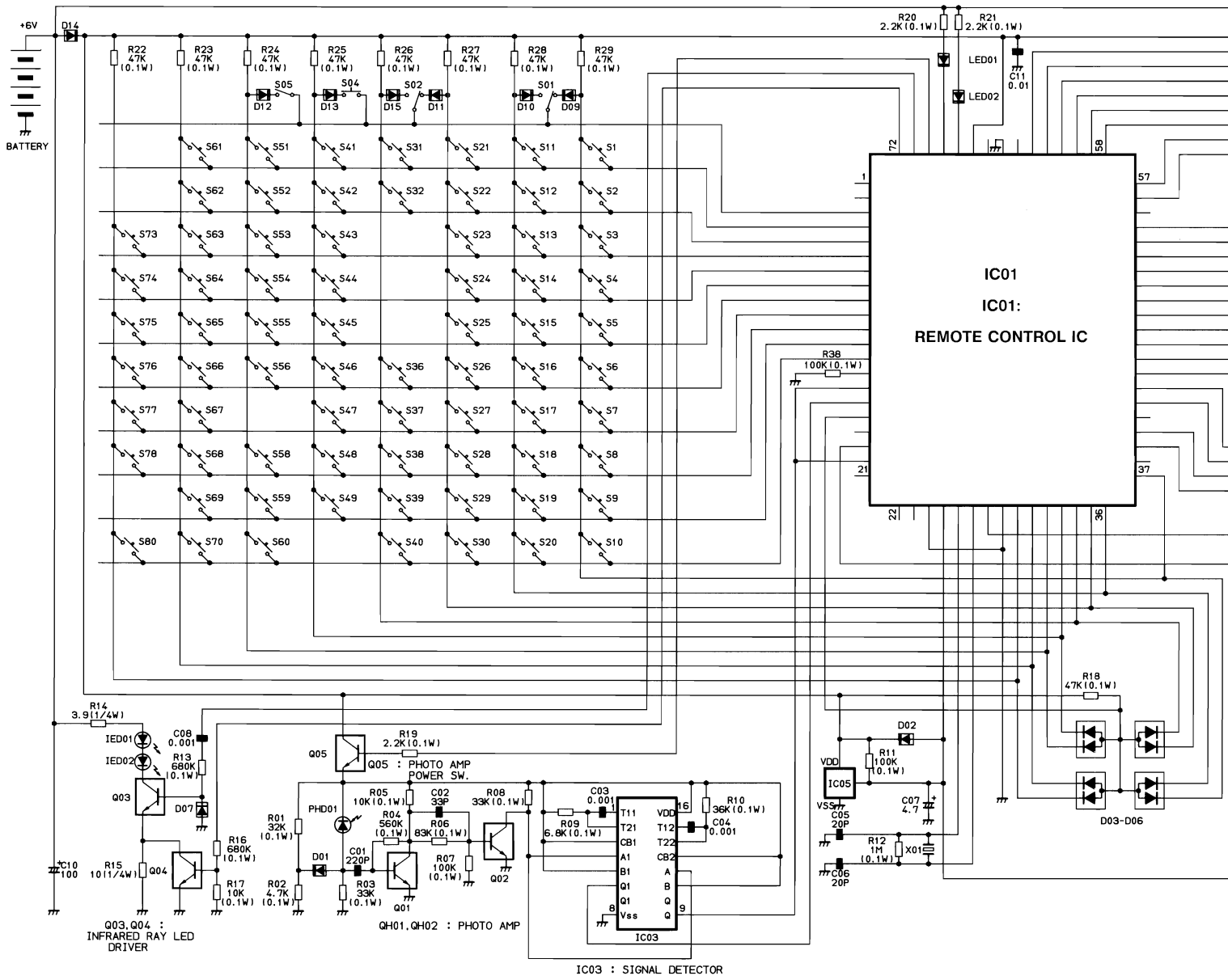

1. RESISTORS:

Indicated in Ω, 1/8, 1/4W, ±5% tolerance unless otherwise noted
K; kΩ, M; MΩ, (F); ±1%, (G); ±2%, (K); ±10%, (M); ±20%
tolerance.

2. CAPACITORS:

Indicated in capacity (μF) / voltage (V) unless otherwise noted p; pF.
Indication without voltage is 50V except electrolytic capacitor.

3. OTHERS

- : Signal route.
- ⊗: Adjusting point.
- The Δ mark found on some component parts indicates the importance of the safety factor of the part. Therefore, when replacing, be sure to use parts of identical designation.
- * marked capacitor and resistor have parts number.
- This is the basic schematic diagram, but the actual circuit may vary due to improvements in design.

4. SWITCHES (The underline indicates the switch position)

- S01 : AUDIO/VIDEO/AUX
- S02 : SR RECALL/USE/LEARN
- S05 : DECK I/DECK II
- S04 : RESET

TAPE/VCR

- S-1 : VCR POWER
- S-2 : TAPE/VCR
- S-3 : TAPE/VCR
- S-4 : / VCR CH-
- S-5 : TAPE SELECT
- S-6 : / ANT
- S-7 : / ANT
- S-8 : / ANT
- S-9 : / ANT
- S-10 : / ANT

CD/LD

- S-11 : / SEARCH
- S-12 : / SEARCH
- S-13 : CD/LD POWER
- S-14 : CHP/FR-TM
- S-15 : DISC SEL DISPLAY
- S-16 : / ANT
- S-17 : / ANT
- S-18 : / ANT
- S-19 : / ANT

TUNER/CD/TV/LD

- S-20 : 1
- S-21 : 2
- S-22 : 3
- S-23 : 4
- S-24 : 5
- S-25 : 6
- S-26 : 7
- S-27 : 8
- S-28 : 9
- S-29 : 0, 10
- S-30 : 11/MEMORY
- S-31 : 12/CLEAR

TUNER/CD/PHONO/AMP/TV

- S-32 : BAND/CH-RTN
- S-36 : PGM
- S-37 : FREQUENCY - /TV CHANNEL -
- S-38 : FREQUENCY + /TV CHANNEL +
- S-39 : TV POWER
- S-40 : CD + 10/TV FUNC
- S-41 : PHONO / TV VOL -
- S-42 : PHONO / TV VOL +
- S-43 : LD
- S-44 : VIDEO
- S-45 : VCR 2
- S-46 : VCR 1
- S-47 : TV
- S-48 : TAPE 2
- S-49 : TAPE 1
- S-51 : TUNER
- S-52 : PHONO
- S-53 : DIRECT/TV. SEL
- S-54 : CENTER MODE
- S-55 : TV DISP
- S-56 : DUAL

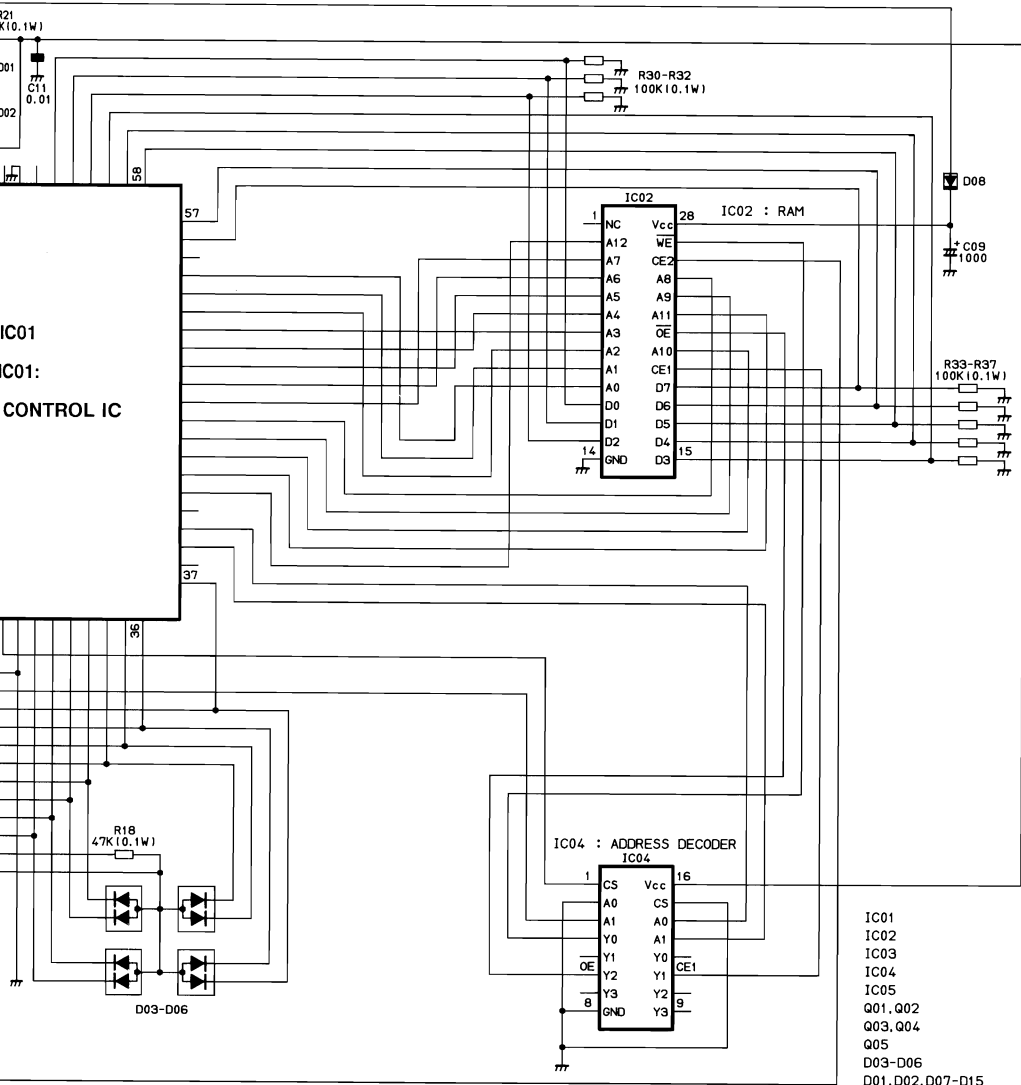

IC01	PD5149A
IC02	AZC1045
IC03	AZC1046
IC04	AZC1047
IC05	AZC1048
Q01, Q02	AZC1050
Q03, Q04	AZC1051
Q05	AZC1052
D03-D06	AZC1049
D01, D02, D07-D15	AZC1233
PHD01	AZC1055
LED01, LED02	AZC1053
LED01, LED02	AZC1054

P.C. BOARD PATTERN

NOTE:

- ⊖ : Indicates a chip resistor
- ⊖ : Indicates a chip capacitor
- ⊖ : Indicates a chip transistor
- ⊖ : Indicates a chip diode.

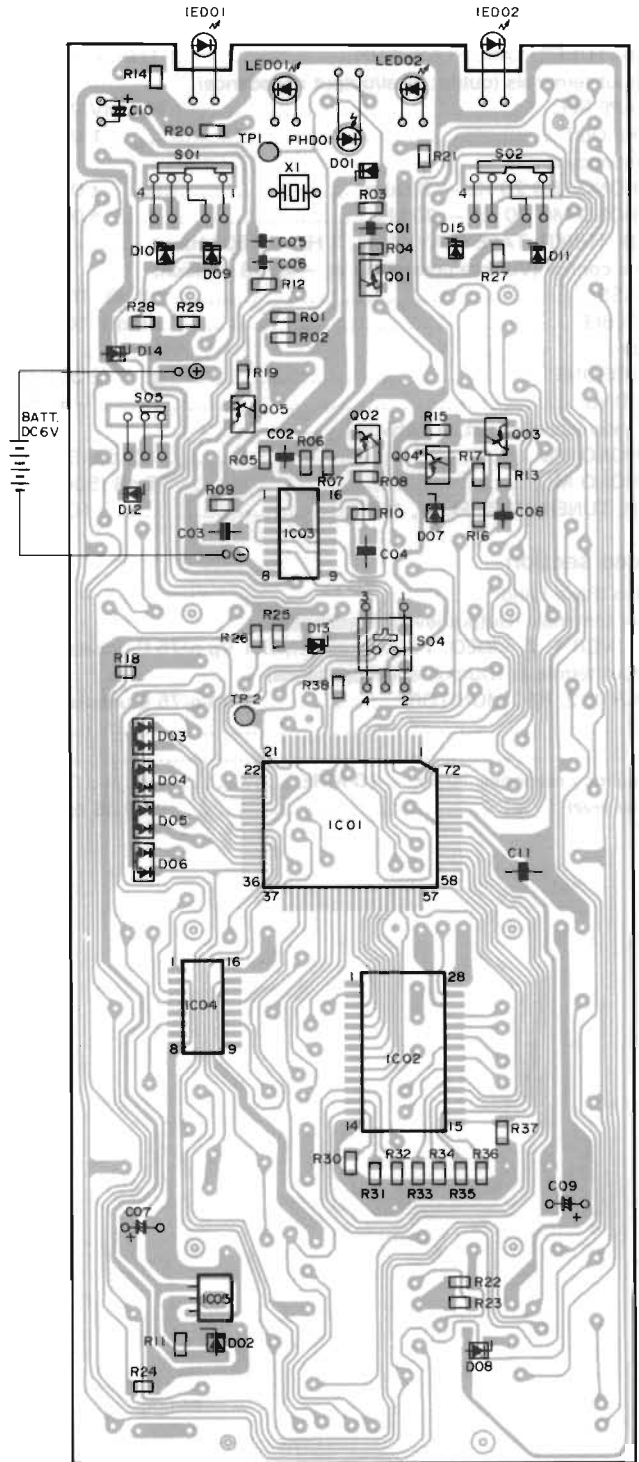
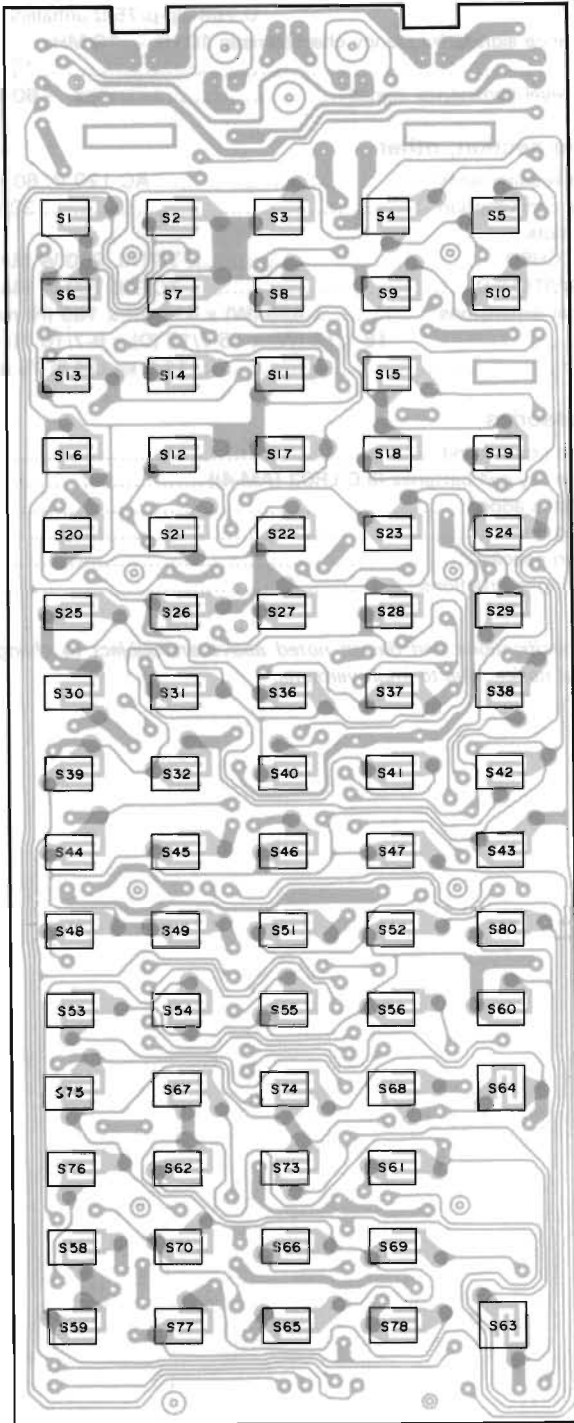

3.4 SPECIFICATIONS

Amplifier Section

Rated output	
20 Hz – 20 kHz, 0.01 % 10 k Ω	7 V
Total harmonic distortion	
20 Hz – 20 kHz, 1 V	0.002 %
Input terminals (sensitivity/impedance)	
PHONO MM	2.5 mV/50 k Ω
PHONO MC	250 μ V/100 Ω
CD, TUNER, TAPE PLAY, AUX	150 mV/50 k Ω
Output terminals (output level/output impedance)	
TAPE REC	150 mV/2.2 k Ω
PRE OUT	1 V/1 k Ω
Frequency response	
PHONO MM 20 Hz – 20 kHz	\pm 0.2 dB
PHONO MC 20 Hz – 20 kHz	\pm 0.3 dB
CD, TUNER, TAPE PLAY, AUX, 1 Hz – 150 kHz	\pm 0 dB
Tone control (Volume control set at – 40 dB position)	
BASS	\pm 8 dB, 100 Hz
TREBLE	\pm 8 dB, 10 kHz
Filter	
SUBSONIC	17 Hz, – 12 dB/oct
MUTING	– ∞ dB
SN ratio (short-circuit, A network)	
PHONO MM	93 dB (5 mV)
PHONO MC	76 dB (500 μ V)
CD, TUNER, TAPE PLAY, AUX	106 dB

Video section

Video (Base Band)	
Input terminals (Output level/impedance)	
LD, VCR 1, 2, VIDEO, TV/AUX	1 Vp-p/75 Ω unbalanced
Output terminals (Output level/impedance)	
VCR 1, 2, REC MONITOR	1 Vp-p/75 Ω unbalanced
DG	2 %
DP	2°
Frequency response 10 Hz – 10 MHz	\pm 0 dB
Noise level	– 60 dB or less

S type terminal

Input terminal (luminance signals sensitivity/impedance, color signals sensitivity/impedance)	
LD, VCR 1, 2, VIDEO, TV/AUX	1 Vp-p/75 Ω unbalanced
	0.286 Vp-p/75 Ω unbalanced
Output terminal (luminance signals output level/impedance, color signals output level/impedance)	
VCR 1, 2, MONITOR	1 Vp-p/75 Ω unbalanced
	0.286 Vp-p/75 Ω unbalanced
Luminance signals frequency characteristic 10 Hz – 10 MHz	
.....	\pm 0 dB
Noise level (luminance signal)	max. – 60 dB

Power section, other

Power requirements	AC 120 V, 60 Hz
Power consumption	30 W
AC outlets	
SWITCHED	TOTAL 900 W MAX
UNSWITCHED	TOTAL 100 W MAX
External dimensions	459 (W) x 417 (D) x 163 (H) mm
	18-1/16 (W) x 16-7/16 (D) x 6-7/16 (H) in
Weight	11.3 kg (24 lb 15 oz)

Accessories

Remote control unit	1
Alkaline dry cell batteries (IEC LR03 (AM-4))	4
Templates added	2
Pin-plug cord	1
Cushion spacer	2
Operating Instructions	1

The specifications and design noted above are subject to change without notice, due to improvements.

3.5 PANEL FACILITIES

FRONT PANEL

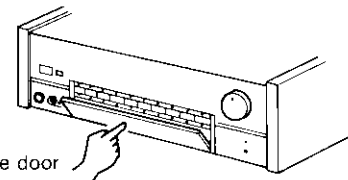
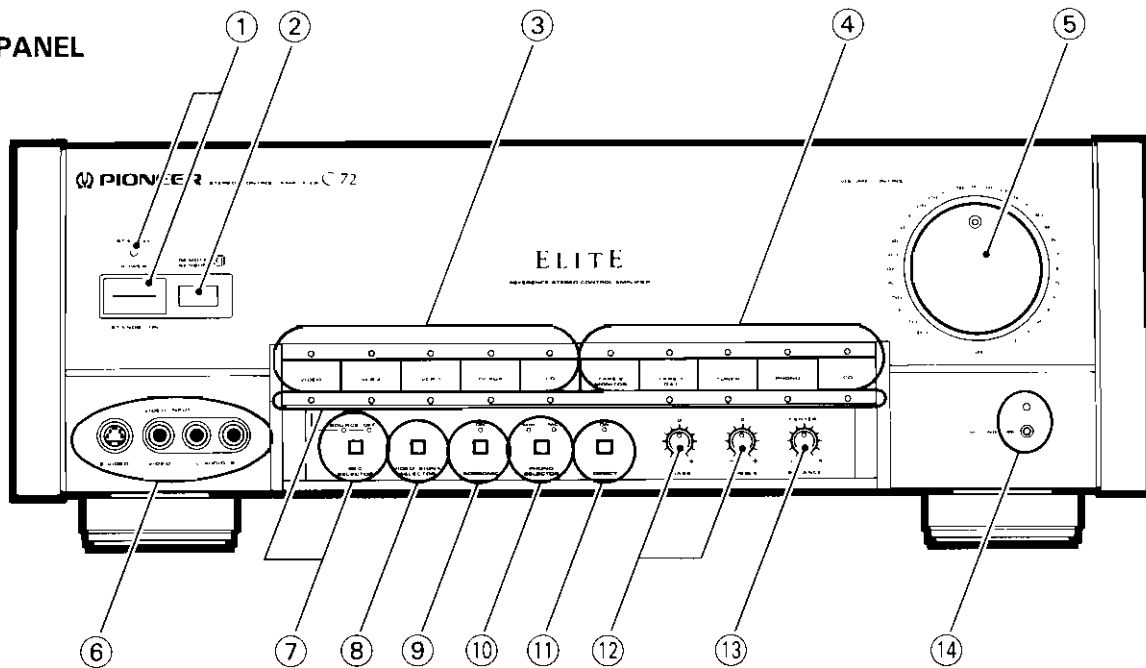

Press the top part of the door in the center to open.

① POWER STANDBY/ON switch/indicator

This is the switch for electric power.

ON: When set to the ON position, power is supplied and the unit becomes operational. The STANDBY indicator is off.

STANDBY: When set to the STANDBY position, the main power flow is cut and the unit is no longer fully operational. A minute flow of power feeds the unit to maintain operation readiness. At this time the STANDBY indicator is on.

② REMOTE SENSOR

③ VIDEO INPUT selector buttons/indicators

Use to select the video component for play back.

[VIDEO]: To play back the video equipment connected to the front panel VIDEO INPUT terminals.

[VCR 2]: To play back the VCR connected to the rear panel VCR 2 terminals.

[VCR 1]: To play back the VCR connected to the rear panel VCR 1 terminals.

[TV/AUX]: To use the TV tuner or a monitor TV connected to the rear panel TV/AUX terminals.

[LD]: To play back the video disc player connected to the rear panel LD terminals.

- The red indicator above the button lights to show the selected video source.
- When selecting with the VIDEO SIGNAL SELECTOR button (8), a yellow indicator above the button lights.
- The indicator under the button lights when selection is made with the REC SELECTOR button (7).

④ AUDIO INPUT selector buttons/indicators

Use to select the audio component for playback.

[TAPE 2 MONITOR]: To use the cassette deck connected to the rear panel TAPE 2 MONITOR terminals.

[TAPE 1/DAT]: To use the cassette deck connected to the rear panel TAPE 1/DAT terminals.

[TUNER]: For listening to FM/AM broadcasts with a tuner.

[PHONO]: For turntable.

[CD]: For compact disc player.

- The TAPE 2 MONITOR button go ON or OFF alternately each time they are pressed, independently of the other buttons.
- The red indicator above the button lights to show the selected audio source.
- The indicator under the button lights when selection is made with the REC SELECTOR button (7).

⑤ VOLUME CONTROL

Use to adjust the sound volume. At the [- ∞] position, sound will not be heard, while at the [0] position, sound volume will be at its maximum.

⑥ VIDEO INPUT terminals

Video components such as a video camera can be connected here.

AUDIO: Connect to the video component's audio output terminals.

VIDEO: Connect to the video component's video output terminal.

S-VIDEO: Connect to the video component's S-VIDEO OUT terminal.

⑦ REC SELECTOR button/indicators

Use to select the playback source component used when performing audio and video recording. The audio and video signals (in the case of an audio component) from the select component will be output from the OUTPUT terminals. When set to SOURCE (indicator lights), the signals selected with the audio or video input selector switch will be output.

Each time you press the REC SELECTOR button, the playback source changes in sequence in the following order.

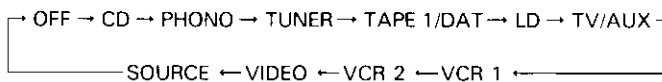

NOTE:
No signal is output to the OUT (or REC) terminal of the input component selected with the recording selector switch. For example, when REC SELECTOR is used to select VCR 1, no signal will be output to the OUT terminal of VCR 1.

⑧ VIDEO SIGNAL SELECTOR button

Use to switch the video component's video signal regardless of the position of the input selector switch. The yellow indicator above the video input selector buttons to show the video signal selected with these buttons.

Each time you press the VIDEO SIGNAL SELECTOR button, the video source changes in sequence in the following order.

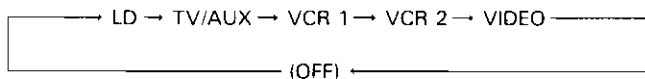

Even when listening to an audio component (record player, tuner, etc.), this button can be used to perform video recording and playback while continuing to listen to the audio component playback. In the OFF position, there is no video signal from the MONITOR OUT jacks.

⑨ SUBSONIC button/indicators

When the button is pressed to the ON position, the indicator lights and the subsonic filter acts to cut out all frequencies below 17 Hz.

⑩ PHONO SELECTOR button/indicators

Set in accordance with the type of cartridge used on your record player (the corresponding indicator will light).

[MM]: Set here when using a moving magnet cartridge, or a high-output (1 mV or more) moving coil (MC) cartridge.

[MC]: Set here when using a moving coil cartridge.

⑪ DIRECT button/indicator

Use this to listen to the audio signal without routing it through subsonic, tone control (BASS, TREBLE), or balance control circuitry.

NOTE:
When the DIRECT button is in the ON position, the TAPE 2 MONITOR button and SUBSONIC button do not operate.

⑫ Tone controls

[BASS]: Use to adjust low frequency sounds. The central |0| indicates the standard (flat) position. When the control is rotated to the right, low-frequency sounds are augmented; when rotated to the left, low-frequency sounds are attenuated.

[TREBLE]: Use to adjust high-frequency sounds. The central |0| indicates the standard (flat) position. When the control is rotated to the right, high-frequency sounds are augmented; when rotated to the left, high-frequency sounds are attenuated.

⑬ BALANCE control

Normally leave in the center position. Use to adjust the balance of sound from right and left channels.

⑭ MUTING button/indicator

Use to temporarily cut the sound. The muting function is on when the MUTING indicator lights. Press the button again to turn the muting function off and return the sound volume to the normal level.

NOTE:
When listening at high volume levels, even if you switch MUTING ON, you will still hear a faint sound.

REAR PANEL

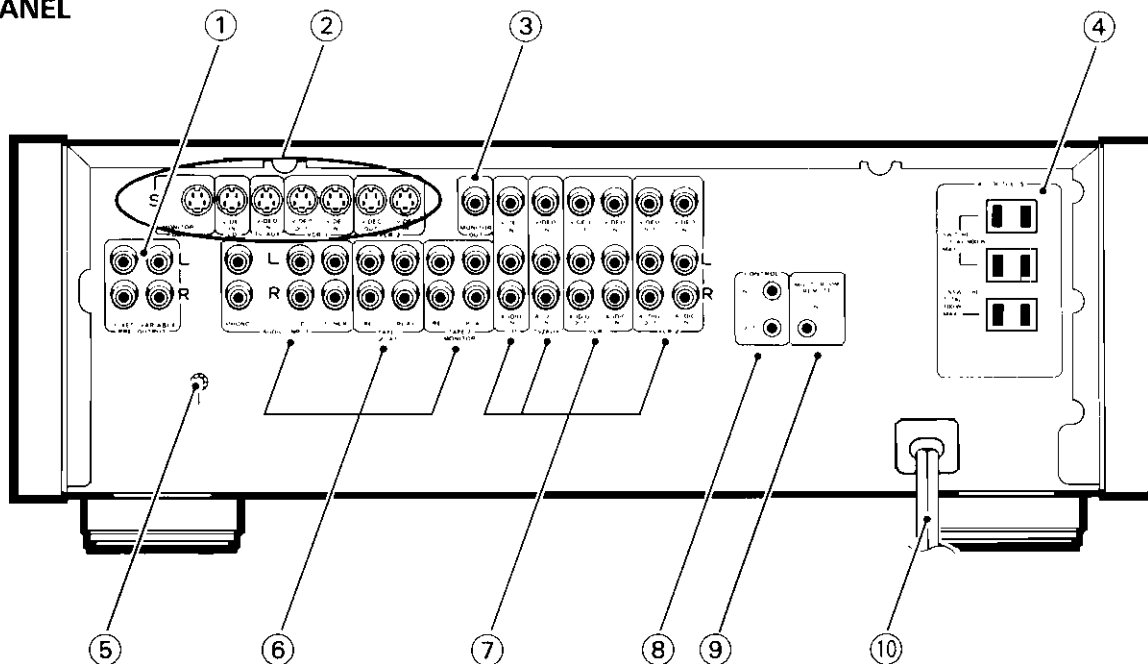

① PRE OUTPUT terminals

Connect to the power amplifier or surround processor input terminals.

FIXED: The output level of the signal is fixed, regardless of this unit's VOLUME CONTROL setting.

Connect to a surround processor with volume control capability.

VARIABLE: Adjust the output level of the signal with this unit's VOLUME CONTROL.

When using with a power amplifier, connect to this terminal.

When using in combination with a Pioneer M-72 stereo power amplifier, set the M-72's INPUT LEVEL control to MAX, and adjust volume level with this unit's VOLUME CONTROL.

② S VIDEO terminals

When used in conjunction with VCR 1, VCR 2, LaserDisc player or monitor TV equipped with S video terminals, connect to these terminals.

③ MONITOR OUT terminal

This terminal outputs the video playback picture from the video components connected to this unit. Connect to the video input terminal of a monitor TV or television set.

④ AC OUTLETS

SWITCHED TOTAL 900 W MAX

Power supplied through these outlets is turned on and off by this equipment's POWER switch. Total electrical power consumption of commented equipment should not exceed 900 W.

With a switched AC outlet, you can connect a separately sold M-72 power cord.

UNSWITCHED TOTAL 100 W MAX

Power flows continually to this outlet, regardless of whether this equipment is switched ON or OFF. Electrical power consumption of the connected equipment should not exceed 100 W.

NOTE:

- This unit should be disconnected by removing the power plug from the wall socket when not in regular use, e.g. when on vacation.
- Do not connect appliances with high power consumption such as heaters, irons, or television sets to these AC OUTLETS in order to avoid overheating and fire risk.
This can cause the control amplifier to malfunction.

CAUTION: DO NOT CONNECT TV SET OR MONITOR

⑤ Ground (GND) terminal

Connect to the ground terminal of your turntable.

⑥ Audio components terminals

[PHONO]: Turntable.

[CD]: Compact disc player.

[TUNER]: FM/AM Tuner.

[TAPE 1/DAT]: Cassette deck 1 (first deck) or DAT.

PLAY: For playback (connect to the tape deck's PLAY terminals).

REC: For recording (connect to the tape deck's REC terminals).

[TAPE 2 MONITOR]: Cassette deck 2 (second deck).

PLAY: For playback. Connect to the cassette deck PLAY terminals.

REC: For recording. Connect to the cassette deck REC terminal.

⑦ Video components terminals

Connect to the video and audio terminals of the video components you plan to use.

[LD]: LaserDisc player.

[TV]: TV Tuner.

[VCR 1]: Video cassette recorder 1 (first unit).

IN: For input. Connect to the VCR's video and audio output terminals.

OUT: For output. Connect to the VCR's video and audio input terminals.

[VCR 2]: Video cassette recorder 2 (second unit).

IN: For input. Connect to the VCR's video and audio output terminals.

OUT: For output. Connect to the VCR's video and audio input terminals.

⑧ CONTROL terminals

IN: Use a control cord to connect when performing remote operations using this unit's remote control unit in conjunction with the remote sensor on the Pioneer component display.

OUT: The control signal received at the amplifier's signal sensor from the remote control unit is output here to other components. Use a control cord to connect to other components when controlling those components with this remote control unit.

NOTE:

Control connections can be performed only when using Pioneer components bearing the  mark.

⑨ MULTI-ROOM REMOTE IN terminals

Connect the multi-room remote control unit (MR-100; sold separately) to this terminal. You can operate this unit by remote control through the MR-100. It is convenient when this unit is located a separate room.

⑩ Power cord

Connect to a household wall outlet, or the power outlet of an audio timer.









4. FOR C-72/SD TYPE

NOTES:

- Parts without part number cannot be supplied.
- The  mark found on some component parts indicates the importance of the safety factor of the part. Therefore, when replacing, be sure to use parts of identical designation.
- Parts marked by "●" are not always kept in stock. Their delivery time may be longer than usual or they may be unavailable.

CONTRAST OF MISCELLANEOUS PARTS

The C-72/SD type is the same as the C-72/KU/CA type with the exception of the following sections.

Mark	Symbol & Description	Parts No.		Remarks
		C-72/KU/CA type	C-72/SD type	
	AC POWER CORD	ADG1076	ADG1051	
	FU2 FUSE (T250mA)	-----	AEK-037	
	FU3 FUSE (T250mA)	-----	AEK-037	
	FU4 FUSE (T250mA)	-----	AEK-037	
	FU5 FUSE (T250mA)	-----	AEK-037	
	PACKING CASE	AHD1927	AHD1926	
	S1 VOLTAGE SELECT SWITCH	-----	AKX-507	
	S2 VOLTAGE SELECT SWITCH	-----	AKX-507	
	FRONT PANEL	ANB1414	ANB1412	
	OPERATING INSTRUCTIONS (ENGLISH)	ARB1268	ARB1269	
	T1 POWER TRANSFORMER	ATT1122	ATT1123	
	T2 POWER TRANSFORMER	ATT1126	ATT1127	
	STRAIN RELIEF	-----	AEC-882	
	FRONT PANEL	ANB1414	ANB1412	
	AC CORD SPACER	ANG1153	-----	

5. FOR C-73/HEZ TYPE

5.1 P.C.B's PARTS LIST

NOTES:

- Parts without part number cannot be supplied.
- Parts marked by "⊙" are not always kept in stock. Their delivery time may be longer than usual or they may be unavailable.
- The Δ mark found on some component parts indicates the importance of the safety factor of the part. Therefore, when replacing, be sure to use parts of identical designation.
- When ordering resistors, first convert resistance values into code form as shown in the following examples.

Ex. 1 When there are 2 effective digits (any digit apart from 0), such as 560 ohm and 47k ohm (tolerance is shown by J = 5%, and K = 10%).

560Ω	56 × 10 ¹	561.....	RD1/4PS	Ⓜ	Ⓜ	Ⓜ	J
47kΩ	47 × 10 ³	473.....	RD1/4PS	Ⓜ	Ⓜ	Ⓜ	J
0.5Ω	0R5.....		RN2H	Ⓜ	Ⓜ	Ⓜ	K
1Ω	010.....		RS1P	Ⓜ	Ⓜ	Ⓜ	K

Ex. 2 When there are 3 effective digits (such as in high precision metal film resistors).

5.62kΩ	562 × 10 ¹	5621.....	RN1/4SR	Ⓜ	Ⓜ	Ⓜ	F
--------	-----------------------	-----------	---------	---	---	---	---

Mark.	No.	Description	Parts No.	Mark.	No.	Description	Parts No.
VOLUME DRIVE ASS'Y							
				Q720		TRANSISTOR	DTC143ES
OTHERS				Q721-Q724		TRANSISTOR	DTA143ES
VR901	GEAR BOX	ACX1046		Q725-Q727		TRANSISTOR	DTA124ES
				D702-D706		LED(RED)	AEL1099
				D708-D722		LED(RED)	AEL1099
POWER ASS'Y							
SEMICONDUCTORS				D724-D728		LED(RED)	AEL1099
Q801	TRANSISTOR	DTC143ES		D729		LED(RED,AMBER)	AEL1115
D804	DIODE	1SS252		D730,D731		DIODE	1SS252
				D734-D743		DIODE	1SS252
				D745		DIODE	1SS252
CAPACITORS				D750		DIODE	1SS252
Δ C351,C352	CKA (0.01/AC400V)	ACG1002		D752-D757		DIODE	1SS252
OTHER				CAPACITORS			
Δ RY351	RELAY	ASR1027		C401,C402	AUDIO FILM CAPACITOR	CFTXA153J50	
FRONT INPUT ASS'Y				C403,C404	AUDIO FILM CAPACITOR	CFTXA823J50	
CAPACITORS				C405,C406	MYLOR FILM CAPACITOR	CQMA332J50	
C451,C452	CERAMIC CAPACITOR	CCDSL181J50		C701	CERAMIC CAPACITOR	CKCYF103Z50	
C453	CERAMIC CAPACITOR	CKDYF103Z50		C702	CEA(47000/5.5V)	ACH1037	
RESISTORS				C703,C704	CERAMIC CAPACITOR	CKDYF223Z50	
R451,R452	CARBON FILM RESISTOR	RD1/8PM470J		C705	ELECTR. CAPACITOR	CEJA010M50	
OTHER				C706	CERAMIC CAPACITOR	CKCYF103Z50	
	PIN JACK(1P)(LINE5 INPUT)	AKB1082		C707	ELECTR. CAPACITOR	CEJA2R2M50	
				C708	ELECTR. CAPACITOR	CEJA101M10	
CONTROL ASS'Y (AWZ2899)				C709	CERAMIC CAPACITOR	CKCYF473Z50	
SEMICONDUCTORS				C710,C711	CERAMIC CAPACITOR	CKDYF223Z50	
IC701	AMP CONTROL MICOM	PD5139A		C716	ELECTR. CAPACITOR	CEJAR47M50	
IC702,IC703	OUTPUT EXPANDER IC	PD0012A		C717	ELECTR. CAPACITOR	CEJA221M6	
Q703,Q704	TRANSISTOR	DTA124ES		COILS & FILTERS			
Q710	TRANSISTOR	2SA1048		L701	AXIAL INDUCTOR	LAU220K	
Q712,Q713	TRANSISTOR	DTC124ES		RESISTORS			
				VR401	VARIABLE	ACS1062	
Q714	TRANSISTOR	DTA143ES		VR402,VR403	VARIABLE(250K)	ACS1061	
Q715	TRANSISTOR	DTA124ES		OTHER RESISTORS			RD1/8PM
Q716	TRANSISTOR	DTC124ES		SWITCHES			
Q718	TRANSISTOR	DTC124ES		S701-S715	SWITCH	ASG1029	
Q719	TRANSISTOR	DTA143ES		S717	SWITCH	ASG1029	

Mark. No.	Description	Parts No.	Mark. No.	Description	Parts No.	
OTHERS			D313-D316	DIODE	10DF2FD	
X701	CERAMIC RESONATOR	ASS1018	D317,D318	ZENER DIODE	RD27FB	A
			D319,D320	ZENER DIODE	RD18FB2	
			D321,D322	DIODE	1SS252	
AF ASS'Y (AWK1302)						
SEMICONDUCTORS			CAPACITORS			
IC101	OP AMP IC	CXA1297P	C101,C102	PP CAPACITOR(0.01/50V)	ACE1018	
IC201-IC205	E-SW IC	UPD6362C	C103,C104	CERAMIC CAPACITOR	CCDSL181J50	
IC206	OP AMP IC	M5238PF	C105,C106	PP CAPACITOR(0.01/50V)	ACE1018	
IC208,IC209	OP AMP IC	M5238PF	C107,C108	ELECTR. CAPACITOR	CEXANP101M25	
IC210	OP AMP IC	CXA1297P	C109,C110	PP CAPACITOR(0.051/50V)	ACE1049	
IC211	IC	UPC4570C	C111,C112	PP CAPACITOR(0.015/50V)	ACE1030	
IC212	OP AMP IC	M5238PF	C113,C114	ELECTR. CAPACITOR	CEXANP3R3M50	
IC301	REGULATOR IC	NJM78M56FA	C115	CERAMIC CAPACITOR	CKDYF103Z50	
IC302	REGULATOR IC	UPC7812H	C116,C117	CERAMIC CAPACITOR	CKDYB103K50	
Q101-Q104	N-FET	2SK369	C118	ELECTR. CAPACITOR	CEAS100M25	
Q105-Q108	TRANSISTOR	2SC1845	C119	CERAMIC CAPACITOR	CKDYF103Z50	
Q109	TRANSISTOR	2SA992	C120	ELECTR. CAPACITOR	CEAS101M16	
Q110	TRANSISTOR	2SC1845	C121,C122	CERAMIC CAPACITOR	CKDYF103Z50	B
Q111	TRANSISTOR	DTC143ES	C123,C124	CERAMIC CAPACITOR	CCDSL121J50	
Q112	TRANSISTOR	2SC2458	C125,C126	POLYESTER CAPACITOR	CQMXA472J100	
Q113	TRANSISTOR	2SA992	C127,C128	CERAMIC CAPACITOR	CCDCH330J50	
Q114	TRANSISTOR	2SC1845	C129	ELECTR. CAPACITOR	CEANP010M50	
Q115	TRANSISTOR	DTC143ES	C201-C204	CERAMIC CAPACITOR	CCDSL181K500	
Q116	TRANSISTOR	DTA143ES	C205,C206	CERAMIC CAPACITOR	CCDSL121J50	
Q117	TRANSISTOR	2SA1048	C207,C208	CERAMIC CAPACITOR	CCDSL181K500	
Q118	TRANSISTOR	2SC2458	C209,C210	CERAMIC CAPACITOR	CCDSL101K500	
Q119	TRANSISTOR	DTC124ES	C211-C220	CERAMIC CAPACITOR	CCDSL181K500	
Q120	TRANSISTOR	DTC143ES	C221,C222	CERAMIC CAPACITOR	CCDSL271K500	
Q201,Q202	TRANSISTOR	2SC2878	C223,C224	CERAMIC CAPACITOR	CCCCL680K500	
Q209	TRANSISTOR	DTA143ES	C225,C226	ELECTR. CAPACITOR	CEXA4R7M50	
Q213-Q215	TRANSISTOR	DTC143ES	C227,C228	ELECTR. CAPACITOR	CEAS100M25	
Q216	TRANSISTOR	DTA143ES	C229,C230	ELECTR. CAPACITOR	CEAS101M16	
Q221	TRANSISTOR	DTA143ES	C233,C234	ELECTR. CAPACITOR	CEXA4R7M50	
Q222	TRANSISTOR	2SA1048	C235,C236	ELECTR. CAPACITOR	CEXA101M25	
Q225	TRANSISTOR	DTC143ES	C237,C238	ELECTR. CAPACITOR	CEAS010M50	C
Q226	TRANSISTOR	2SC2458	C239,C240	AUDIO FILM CAPACITOR	CFTXA823J50	
Q227	TRANSISTOR	DTA143ES	C241,C242	ELECTR. CAPACITOR	CEAS100M50	
Q228	TRANSISTOR	2SC2458	C243,C244	ELECTR. CAPACITOR	CEAS101M16	
Q301	TRANSISTOR	2SC1845	C245,C246	ELECTR. CAPACITOR	CEXA101M25	
Q302	TRANSISTOR	2SA992	C247,C248	ELECTR. CAPACITOR	CEYA470M25	
Q303,Q304	TRANSISTOR	2SC2705	C249	ELECTR. CAPACITOR	CEAS101M16	
Q305-Q307	TRANSISTOR	2SC3298	C250	ELECTR. CAPACITOR	CEAS010M50	
Q308	TRANSISTOR	2SA1145	C251,C252	CERAMIC CAPACITOR	CKCYF103Z50	
Q309	TRANSISTOR	2SA1306	C253	CERAMIC CAPACITOR	CKDYF103Z50	
Q310	TRANSISTOR	2SA1145	C255,C256	CERAMIC CAPACITOR	CCDSL330J50	
Q311,Q312	TRANSISTOR	2SA1306	C257,C258	CERAMIC CAPACITOR	CCDSL151J50	
D101,D102	DIODE	1SS252	C259-C262	CERAMIC CAPACITOR	CCDSL101J50	
D103,D104	ZENER DIODE	RD12ESB1	C265,C266	CERAMIC CAPACITOR	CCCSL151J50	
D105-D113	DIODE	1SS252	C267,C268	CERAMIC CAPACITOR	CCCSL330J50	
D201-C203	DIODE	1SS252	C301	ELECTR. CAPACITOR	CEAS222M25	D
D208-D216	DIODE	1SS252	C302	ELECTR. CAPACITOR	CEHAQ010M50	
D217,D218	ZENER DIODE	RD12ESB3	C305	ELECTR. CAPACITOR	CEAS102M25	
D219-D223	DIODE	1SS252	C306	CERAMIC CAPACITOR	CKDYF103Z50	
D224	ZENER DIODE	RD10ESB2	C307-C310	ELECTR. CAPACITOR	CEYA102M50	
D301-D308	DIODE	S5566	C311,C312	ELECTR. CAPACITOR	CEYA101M25	

<u>Mark. No.</u>	<u>Description</u>	<u>Parts No.</u>
C313	ELECTR. CAPACITOR	CEHAQ010M50
C314	ELECTR. CAPACITOR	CEAS221M16
C315	ELECTR. CAPACITOR	CEHAQ010M50
C316	ELECTR. CAPACITOR	CEAS221M16
C317	ELECTR. CAPACITOR	CEAS100M50
C318	ELECTR. CAPACITOR	CEAS220M50
C319-C321	CKA(0.01/AC250V)	ACG1005
C322,C324	CERAMIC CAPACITOR	CKCYF103Z50
C323	CERAMIC CAPACITOR	CKCYF473Z50
COILS & FILTERS		
L101,L102	COIL	ATH1010
RESISTORS		
VR201	VARIABLE	ACW1008
R103-R120	CARBON FILM RESISTOR	RDR1/4PM0000J
R121,R122	CARBON FILM RESISTOR	RD1/4PM0000J
R123-R132	CARBON FILM RESISTOR	RDR1/4PM0000J
R133,R134	CARBON FILM RESISTOR	RDR1/2PM0000J
R153	CARBON FILM RESISTOR	RD1/4PM100J
R155-R160	CARBON FILM RESISTOR	RDR1/4PM0000J
R201,R202	CARBON FILM RESISTOR	RDR1/4PM0000J
R203-R218	CARBON FILM RESISTOR	RD1/4PM0000J
R225,R226	CARBON FILM RESISTOR	RD1/4PM0000J
R231,R232	CARBON FILM RESISTOR	RDR1/4PM0000J
R235,R236	CARBON FILM RESISTOR	RD1/4PM0000J
R237,R238	CARBON FILM RESISTOR	RDR1/4PM0000J
R239,R240	CARBON FILM RESISTOR	RD1/4PM0000J
R241-R248	CARBON FILM RESISTOR	RDR1/4PM0000J
R249,R250	CARBON FILM RESISTOR	RDR1/4PM101J
R251-R254	CARBON FILM RESISTOR	RDR1/4PM0000J
R267,R268	CARBON FILM RESISTOR	RDR1/2PM0000J
R269	CARBON FILM RESISTOR	RD1/4PM102J
R271-R280	CARBON FILM RESISTOR	RD1/4PM0000J
R294	CARBON FILM RESISTOR	RD1/4PM100J
R301,R302	FUSIBLE RESISTOR	RFA1/4PS270J
R303-R310	CARBON FILM RESISTOR	RDR1/2PM0000J
R312	CARBON FILM RESISTOR	RD1/4PM100J
OTHER RESISTORS		RD1/8PM0000J
OTHERS		
CN1-CN3	CONNECTOR(15P)	KPE15
CN5	CONNECTOR(9P)	KPC9
CN6	CONNECTOR(5P)	KPC5
RY101-RY103	RELAY	ASR1018
RY201-RY205	RELAY	ASR1018
	SCREW	ABA1027
	PIN JACK(4P)(LINE1-LINE2)	AKB1124
	PIN JACK(6P)(CD-TUNER-TAPE1/DAT)	AKB1129
	PIN JACK(2P)(LINE3-LINE4)	AKB1146
	PIN JACK(6P)(TAPE2 MONITOR)	AKB1148
	PIN JACK(2P)(OUTPUT, PHONO)	AKB1151

5.2 SCHEMATIC DIAGRAM AND P.C. BOARDS CONNECTION DIAGRAM

AF ASS'Y AWK1302

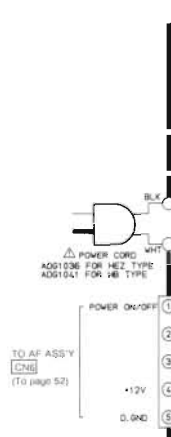
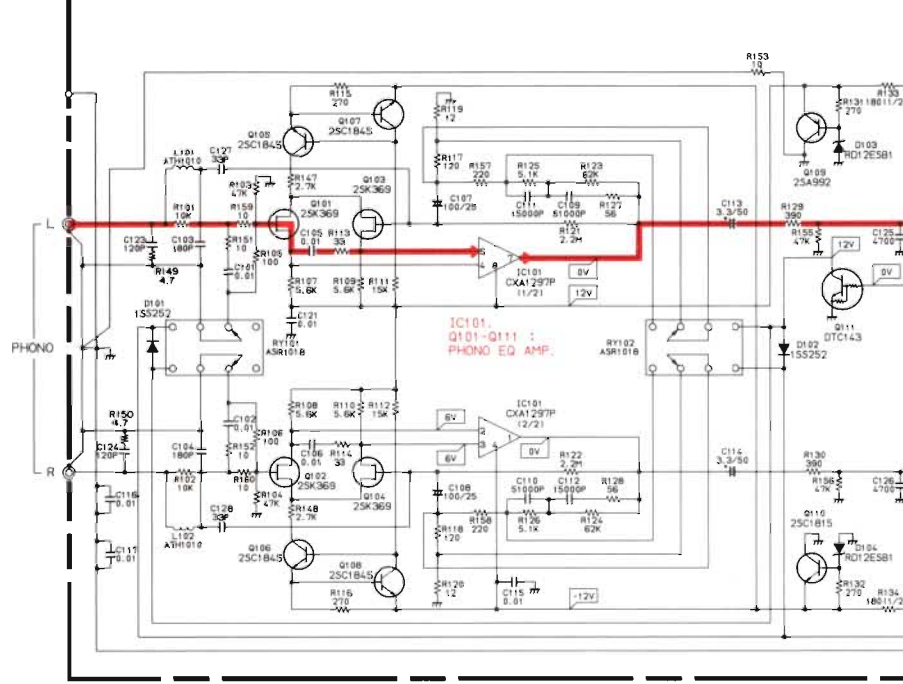

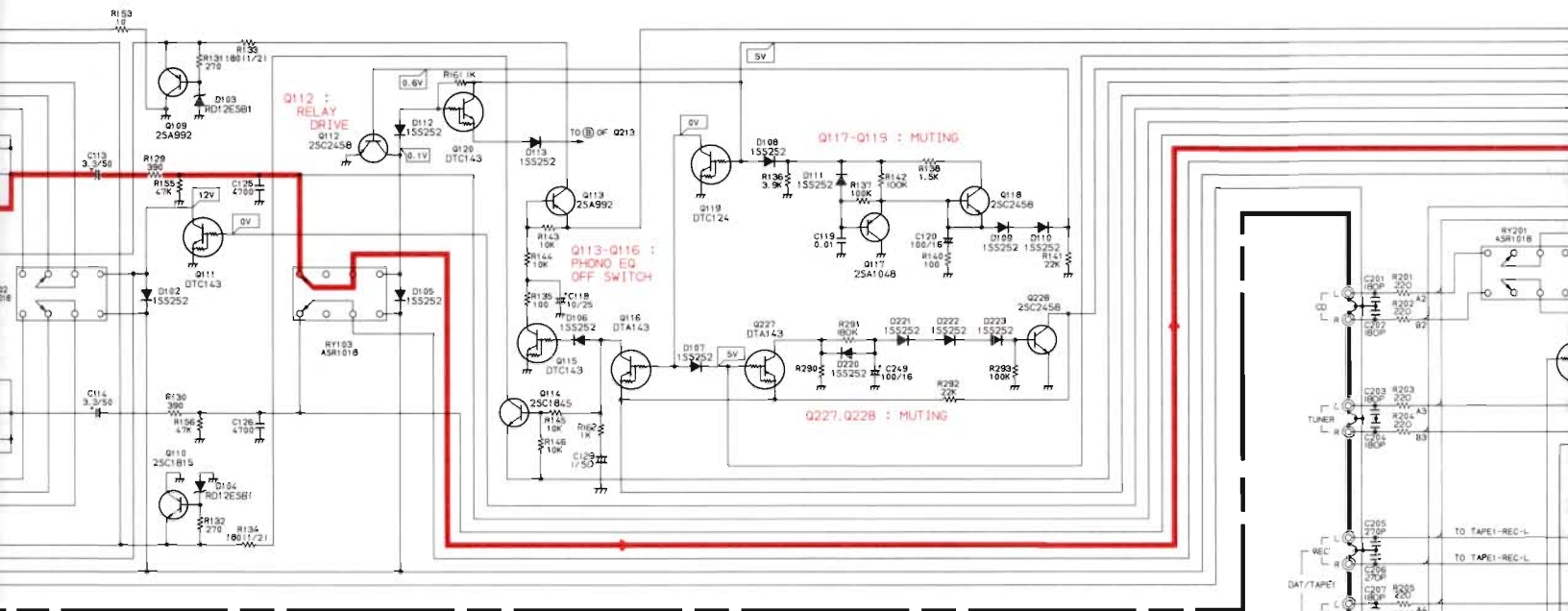

POWER ASS'Y

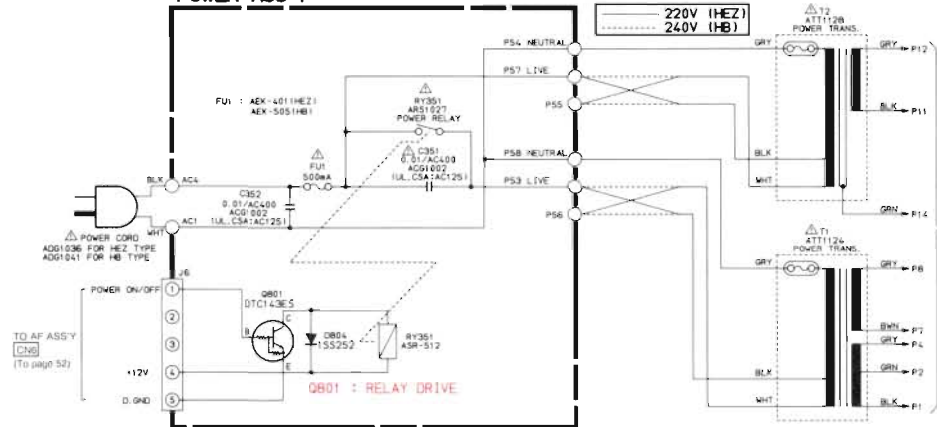

Line Voltage Selection (For HEZ and HB types)

Line voltage can be changed with following steps.

1. Disconnect the AC power cord.
2. Remove the top cover.
3. Change the connection of the power transformers T1 and T2 lead wire.
4. Stick the line voltage label on the rear panel.

Part No.	Description
AAX-193	220V label
AAX-192	240V label

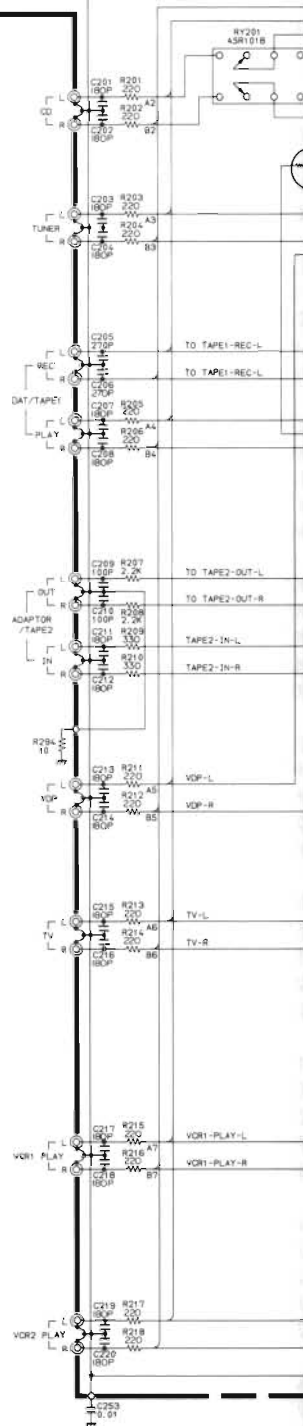

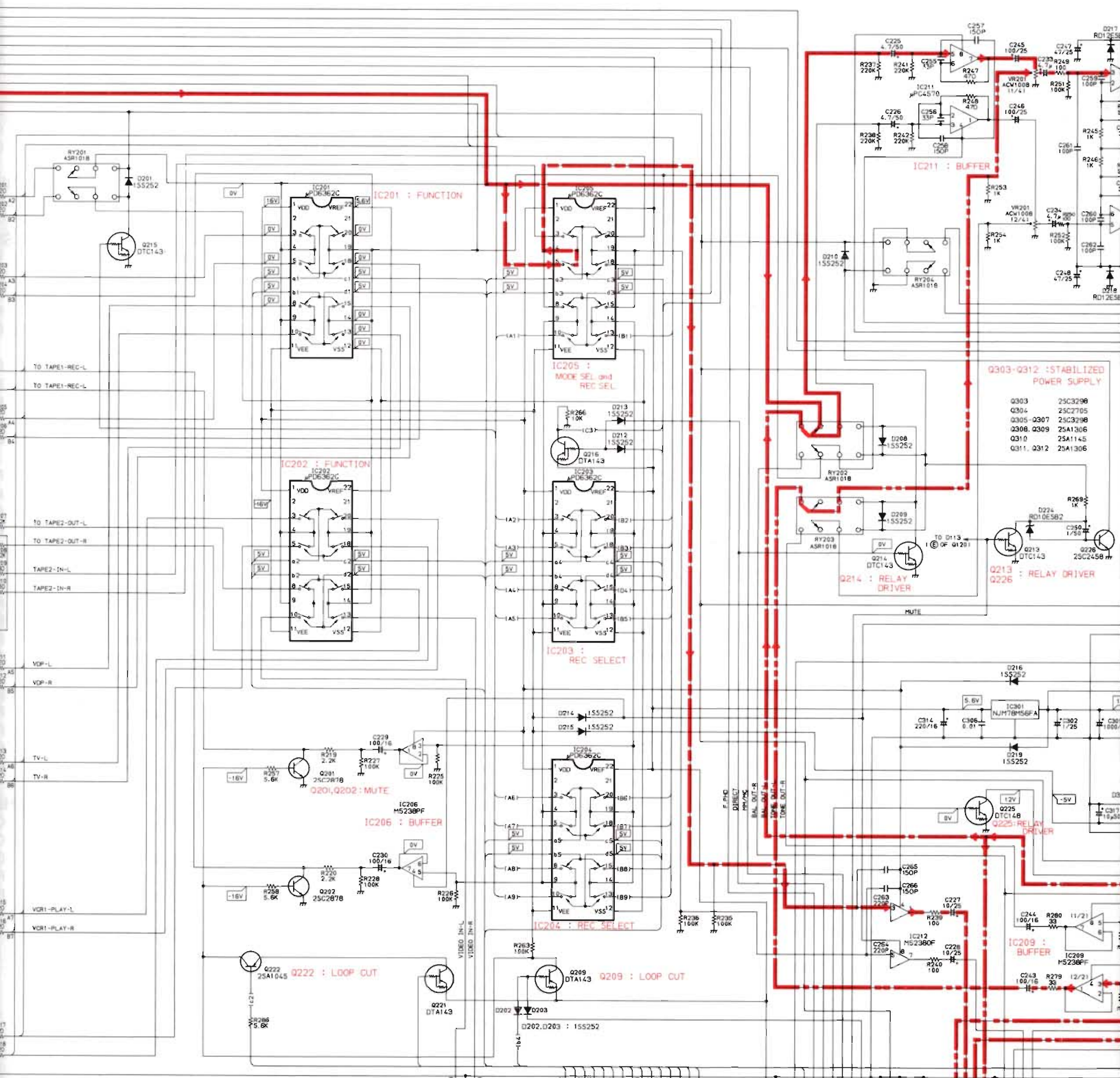

TO FRONT INPUT ASS'Y
(To page 57)

TO CONTROL ASS'Y
(To page 55)

TO CONTROL ASS'Y
(To page 59)

TO CONTROL ASS'Y
(To page 67)

Q303-Q312 : STABILIZED POWER SUPPLY

Q303	25C3298
Q304	25C2705
Q305-Q307	25C3298
Q308, Q309	25A1306
Q310	25A1145
Q311, Q312	25A1306

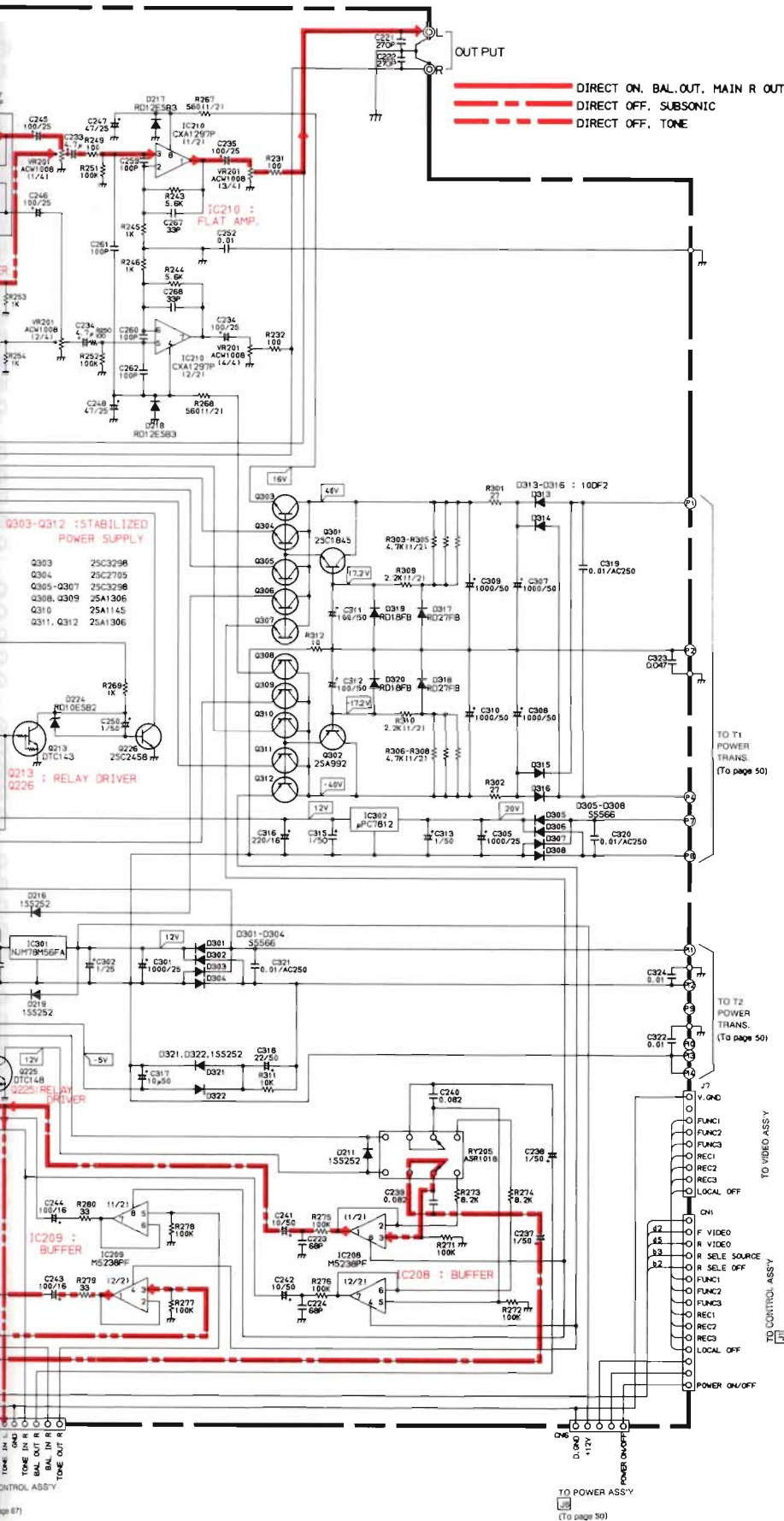

1. RESISTORS:

Indicated in Ω, 1/8, 1/4W, ± 5% tolerance unless otherwise noted
K; kΩ, M; MΩ, (F); ± 1%, (G); ± 2%, (K); ± 10%, (M); ± 20% tolerance.

2. CAPACITORS:

Indicated in capacity (µF) / voltage (V) unless otherwise noted p; pF.
Indication without voltage is 50V except electrolytic capacitor.

3. VOLTAGE CURRENT:

□ : DC voltage (V) at no input signal.
Value in () is DC voltage at rated power.
↻mA : DC current at no input signal.

4. OTHERS

- ← : Signal route.
- ⊗ : Adjusting point.
- The Δ mark found on some component parts indicates the importance of the safety factor of the part. Therefore, when replacing, be sure to use parts of identical designation.
- ✖ marked capacitor and resistor have parts number.
- This is the basic schematic diagram, but the actual circuit may vary due to improvements in design.

5. SWITCHES (The underline indicates the switch position)

- CONTROL Assembly
- S701 : POWER SW (STANDBY-ON)
 - S702 : LINE1
 - S703 : LINE2
 - S704 : LINE3
 - S705 : LINE4
 - S706 : LINE5
 - S707 : PHONO
 - S708 : TAPE 2/MONITOR
 - S709 : CD
 - S710 : TUNER
 - S711 : TAPE 1/DAT
 - S712 : MUTING
 - S713 : SUBSONIC
 - S714 : CPHONO-SEL
 - S715 : DIRECT
 - S717 : REC-SEL

A

B

C

D

POWER ASS'Y

AF ASS'Y (AWK1302)

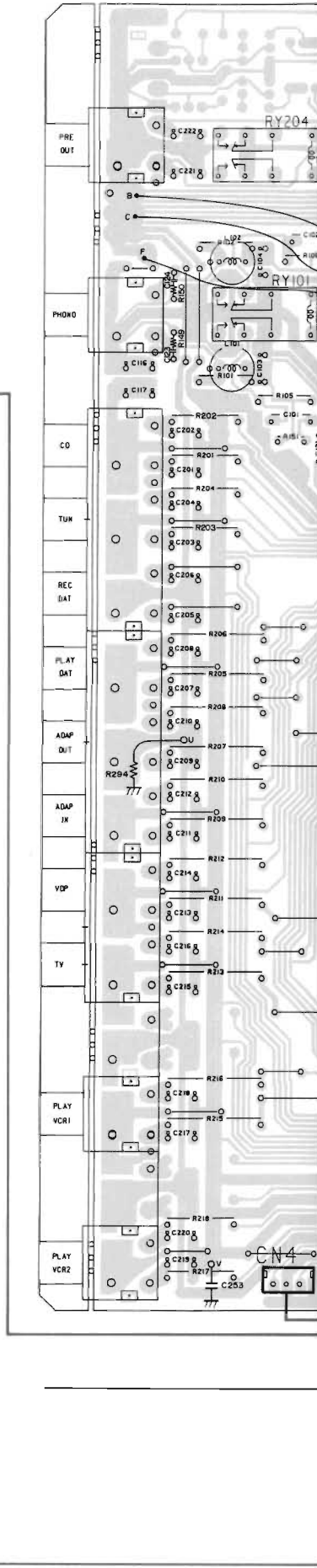
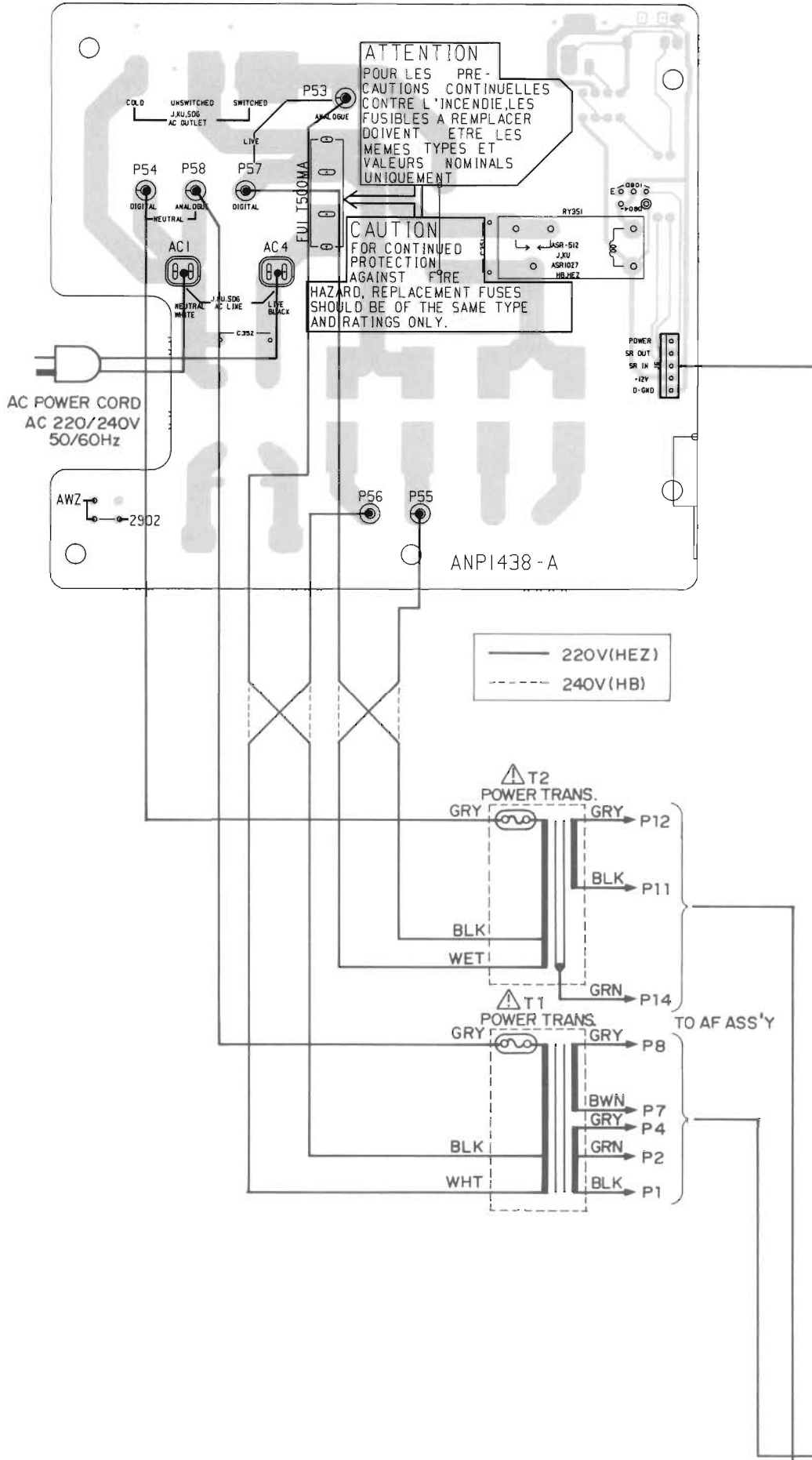

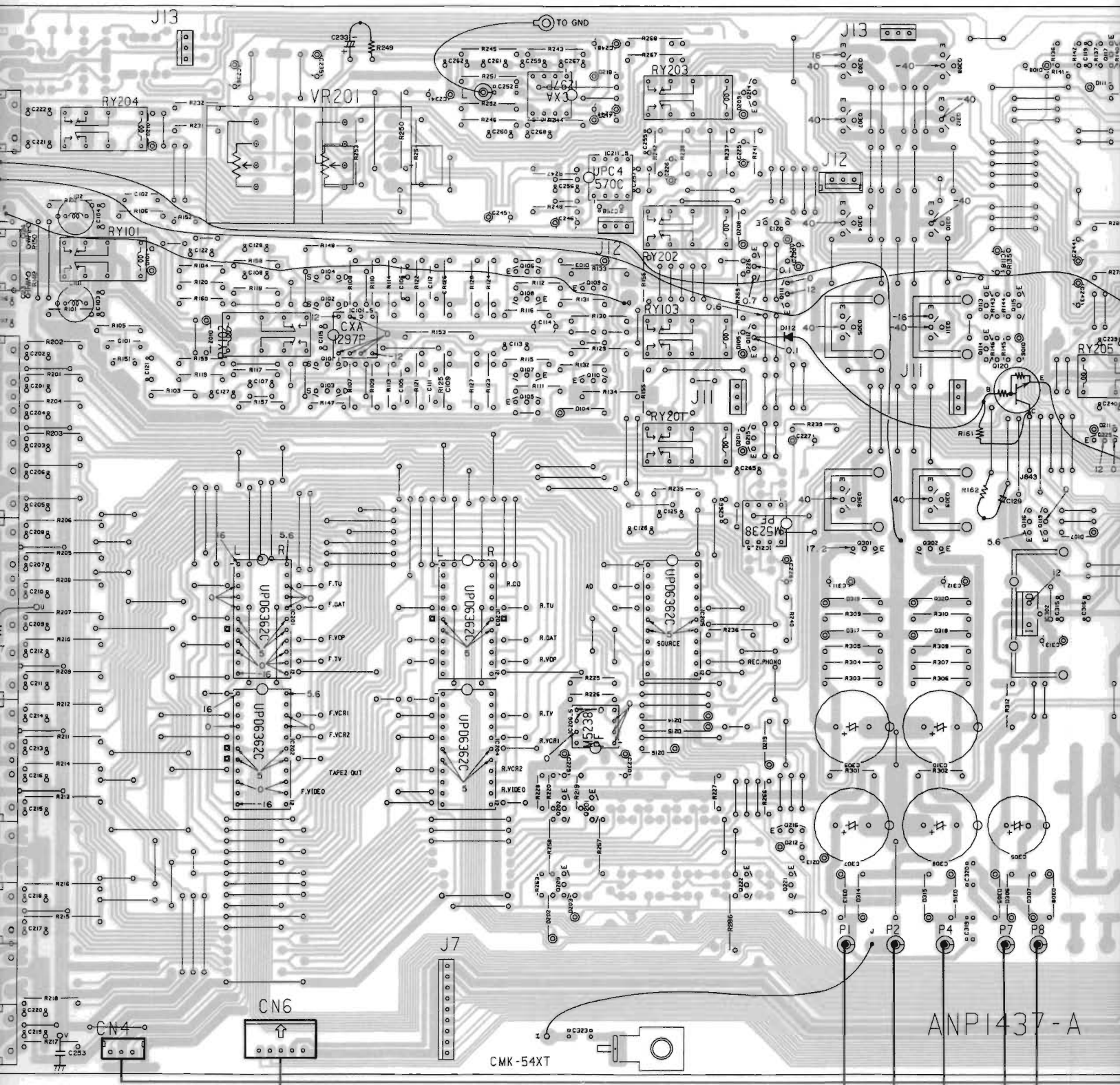

VR201

Q104
Q102 IC101
Q101
Q103

IC201
IC202

IC203
IC204

IC201 IC211
Q106 Q109
Q108 Q110
Q107
Q105

Q202
Q209 Q201

IC205

Q214
Q226 Q213
Q112 Q111
Q215

IC212

Q222 Q216
Q221

TO POWER TRANS. T1

Q303
Q307
Q304
Q305
Q306
Q301
Q308
Q312
Q310
Q311 Q113 Q115
Q309 Q114
Q302 Q116 Q119
Q120 IC302

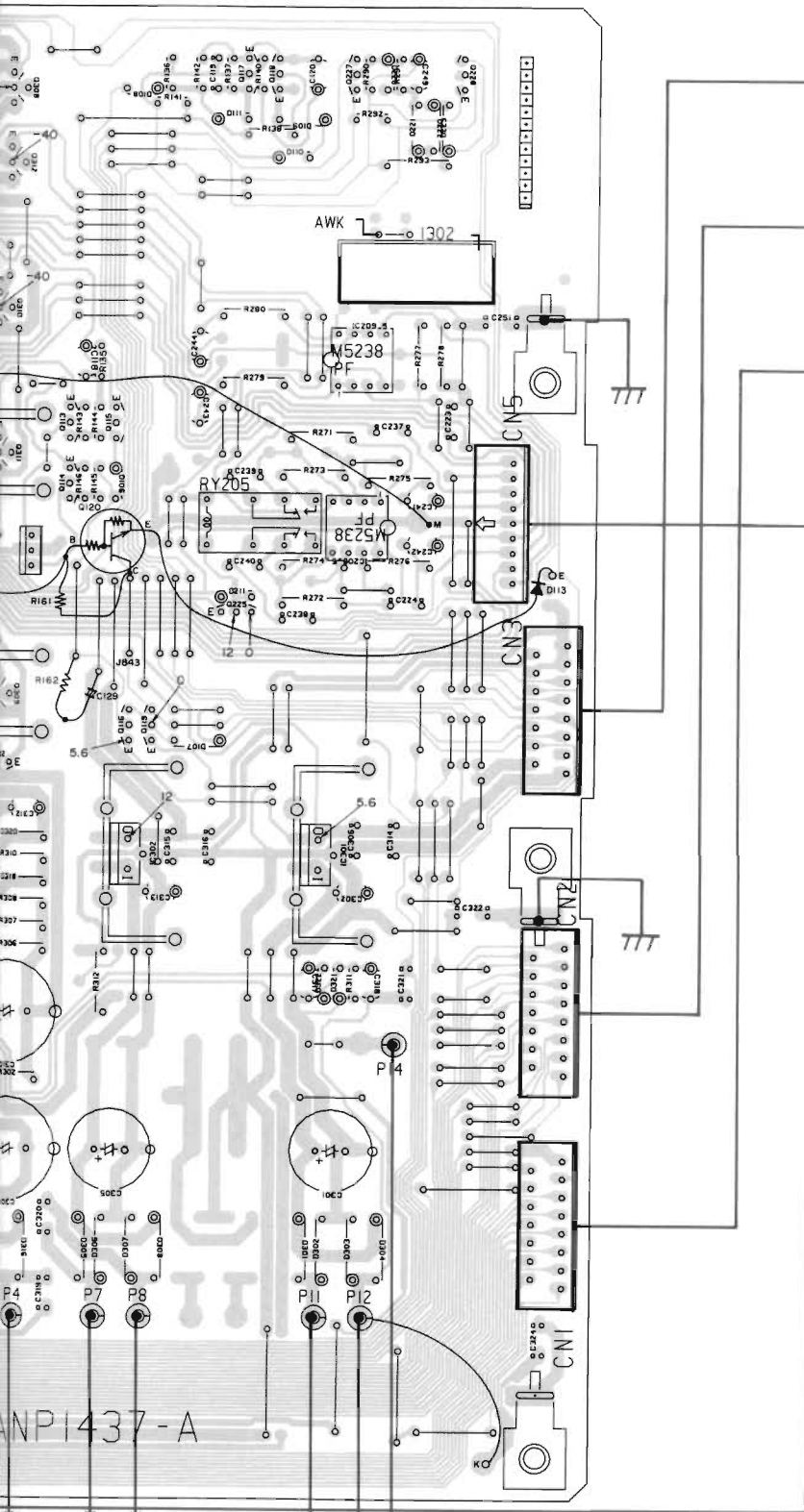

TO CONTROL ASS'Y
J3
 (To page 63)

TO CONTROL ASS'Y
J2
 (To page 63)

TO CONTROL ASS'Y
J1
 (To page 63)

TO CONTROL ASS'Y
J5
 (To page 63)

TO FRONT INPUT ASS'Y
J4
 (To page 62)

1. This P.C.B connection diagram is seen from the parts mount side.
2. The parts mounted on to the P.C.B can be replaced with those shown in the following correspondence table with wiring marks.

Indication of the P.C.B. pattern	Symbol of corresponding parts	Parts name
		Transistor
		Radiator type transistor
		Diode
		Resistor
		Condenser (Polar type)
		Condenser (Non-polar type)

Others

Wiring mark on the P.C.B. pattern diagram	Parts list
IC	IC
S	Switch
RY	Relay
L	Coil
F	Filter
VR	Variable resistor or semi-fixed resistor

3. The condenser terminal marked with double circles (⊙) represents the (-) terminal.
4. The diode terminal marked with double circles (⊙) represents the cathode side.
5. The transistor terminal marked with "E" represents an emitter.

TRANS. T1
 Q117 Q118 Q227 Q228
 Q225 IC209
 Q113 Q115 IC208
 Q114
 Q116 Q119 IC301
 Q120 IC302

TO AF ASS'Y ←

CN3

(To page 55)

TO AF ASS'Y ←

CN2

(To page 55)

TO AF ASS'Y ←

CN1

(To page 55)

TO AF ASS'Y ←

CN5

(To page 55)

TO AF ASS'Y ←

CN4

(To page 54)

CONTROL ASS'Y (AWZ2899)

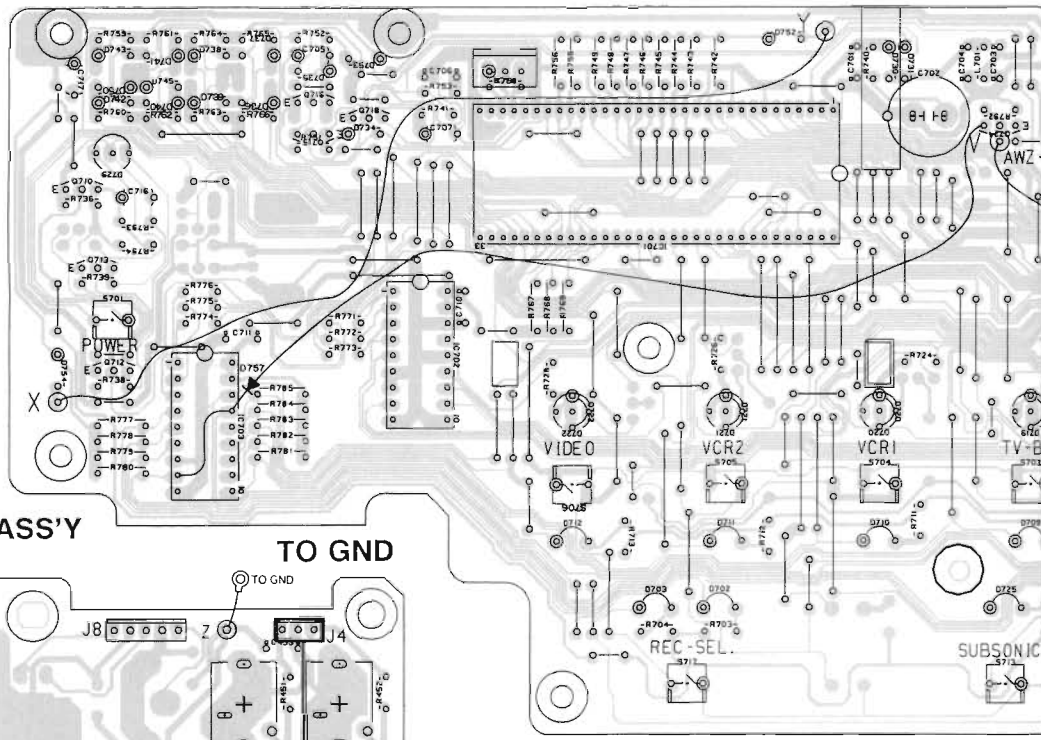

FRONT INPUT ASS'Y

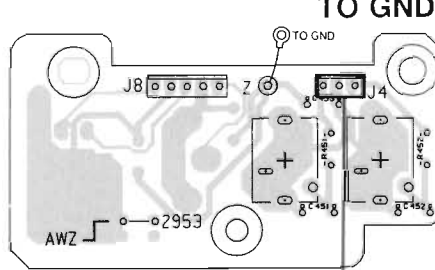

Q710

Q716 Q718

Q724

Q713

Q715

IC701

Q712

IC703

IC702

VOLUME DRIVE

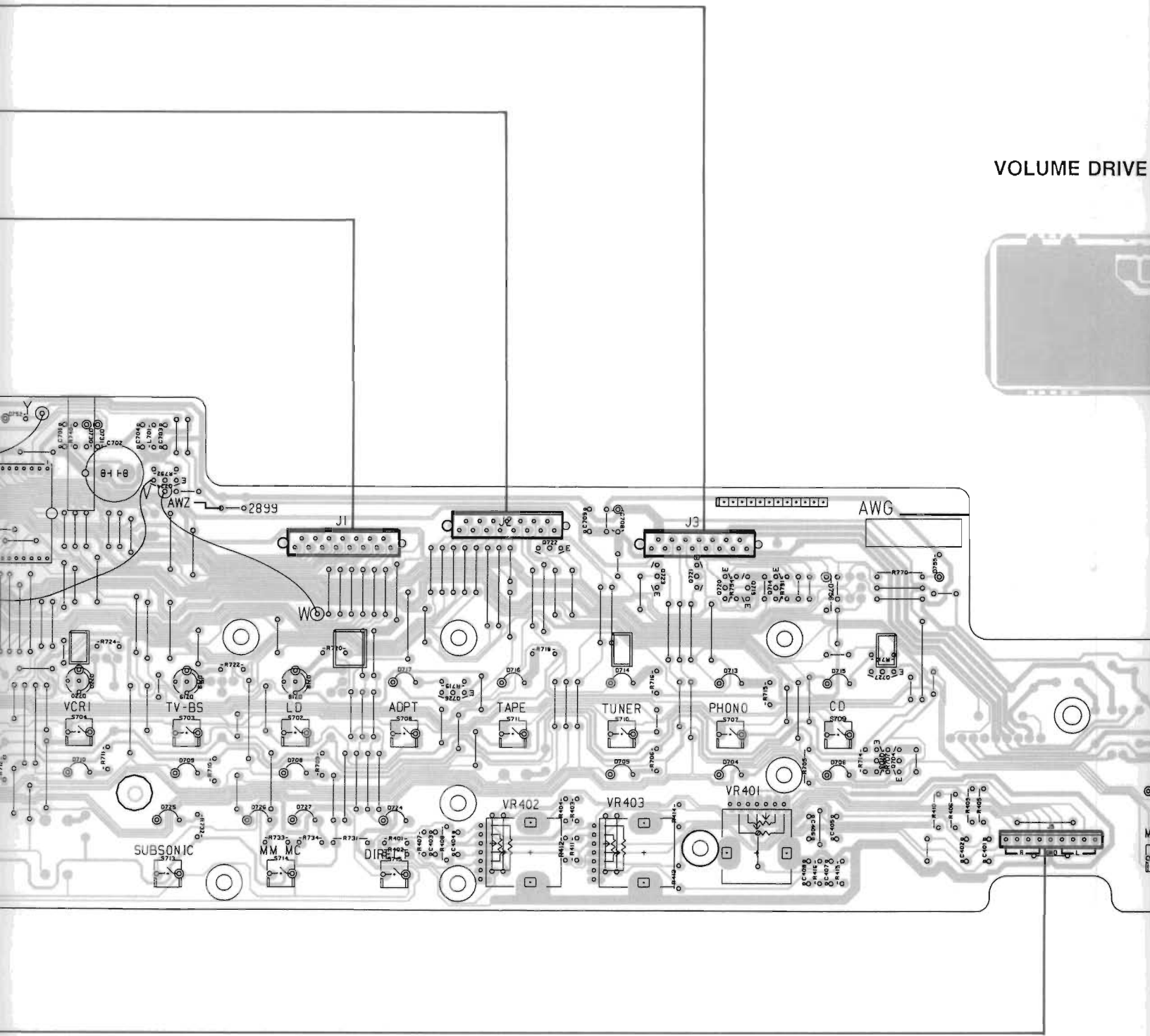

Q724

VR402

VR403

VR401

Q722

Q723 Q721 Q720 Q719 Q714

Q727

Q726

Q704

Q703

VOLUME DRIVE ASS'Y

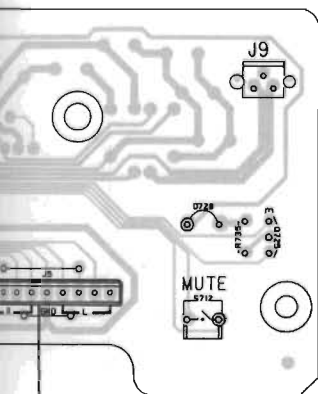
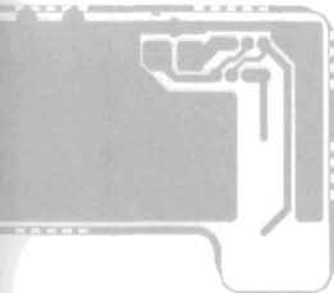

Q725

1. This P.C.B connection diagram is seen from the parts mount side.
2. The parts mounted on to the P.C.B can be replaced with those shown in the following correspondence table with wiring marks.

Indication of the P.C.B. pattern	Symbol of corresponding parts	Parts name
		Transistor
		Radiator type transistor
		Diode
		Resistor
		Condenser (Polar type)
		Condenser (Non-polar type)

Others

Wiring mark on the P.C.B pattern diagram	Parts list
IC	IC
S	Switch
RY	Relay
L	Coil
F	Filter
VR	Variable resistor or semi-fixed resistor

3. The condenser terminal marked with double circles (⊙) represents (-) terminal.
4. The diode terminal marked with double circles (⊙) represents the cathode side.
5. The transistor terminal marked with "E" represents an emitter.

CONTROL ASS'Y AWZ2899 (2/2)

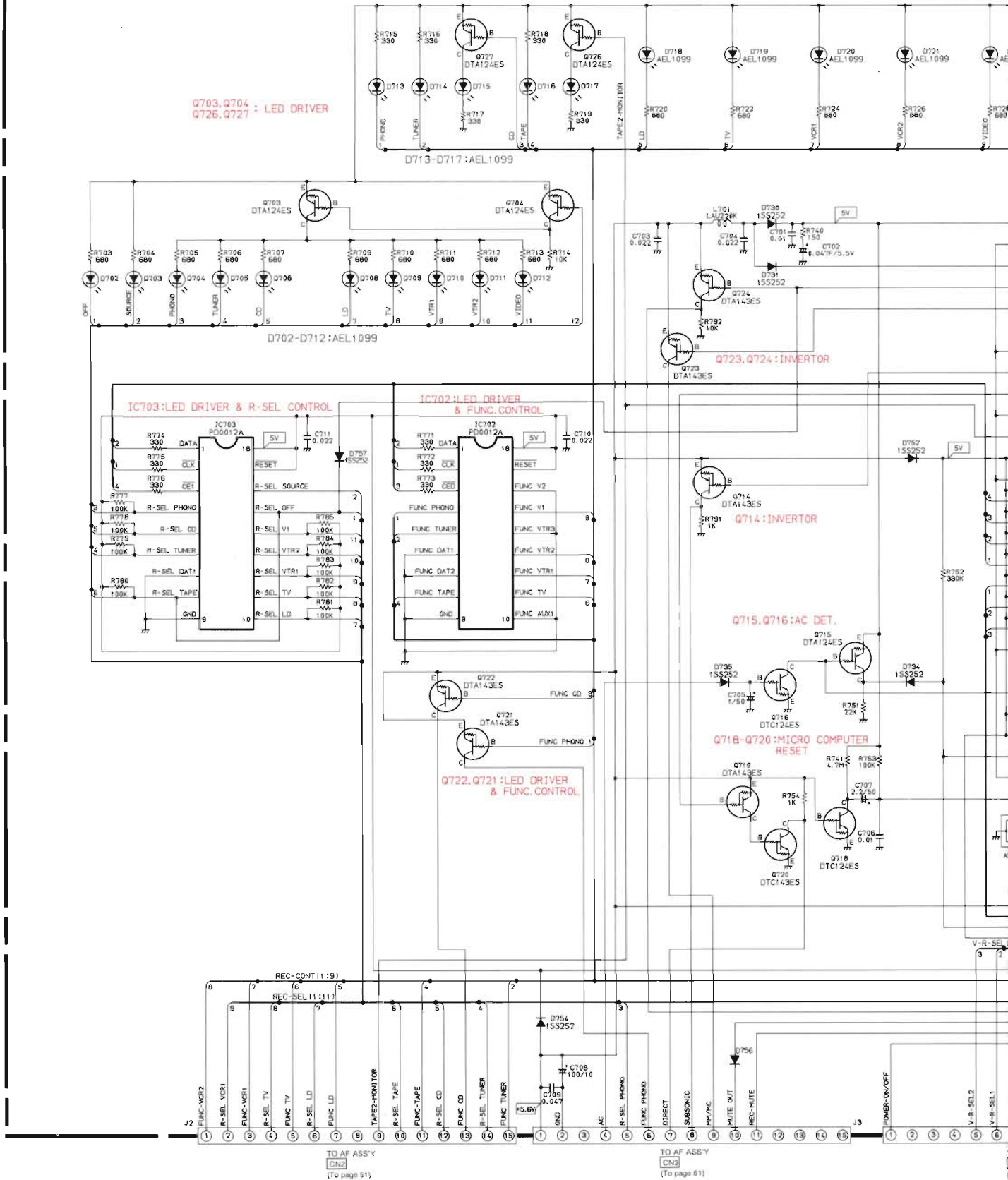

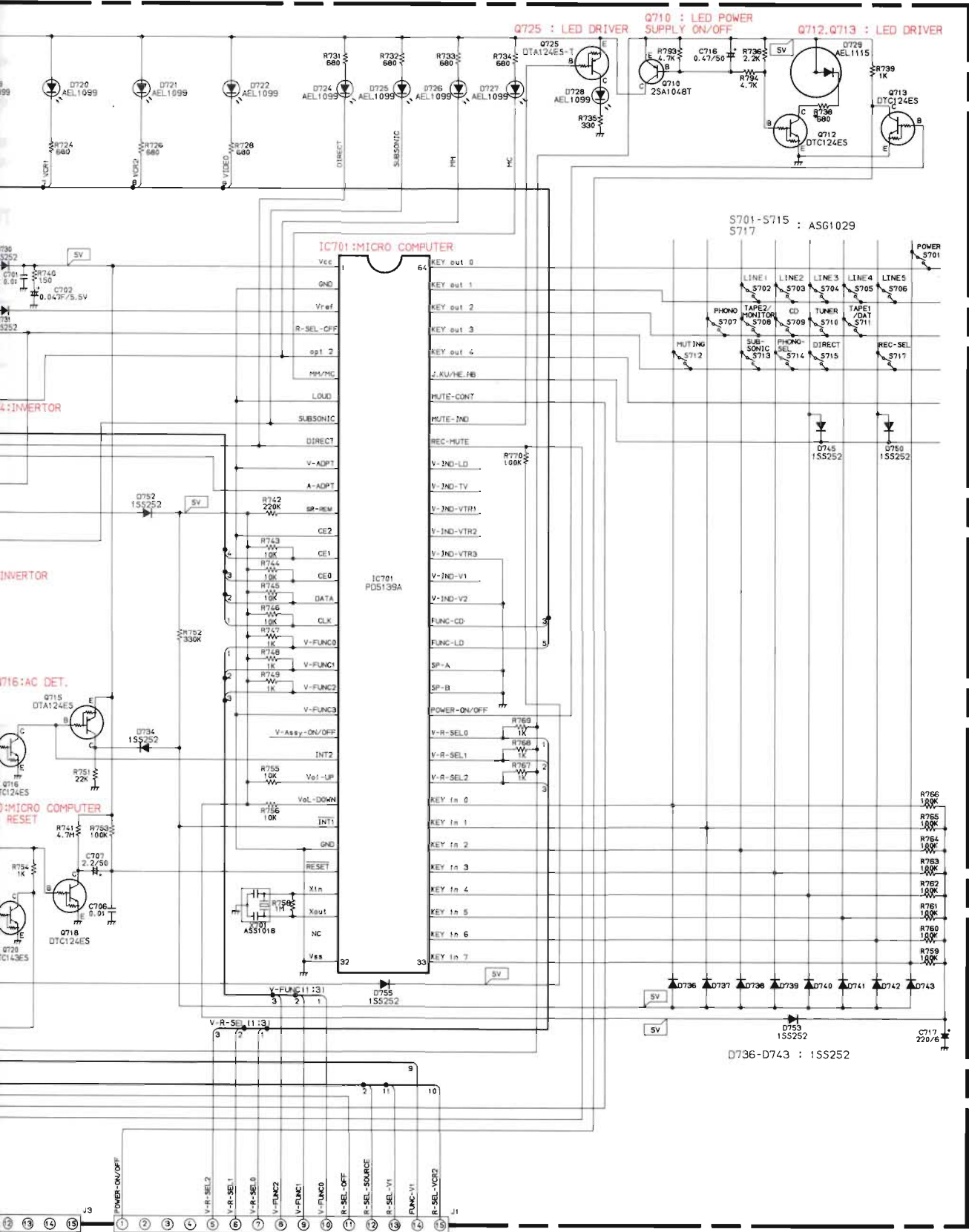

TO AF ASS'Y
 (CN1)
 (To page 52)

A

CONTROL ASS'Y AWZ2899 (1/2)

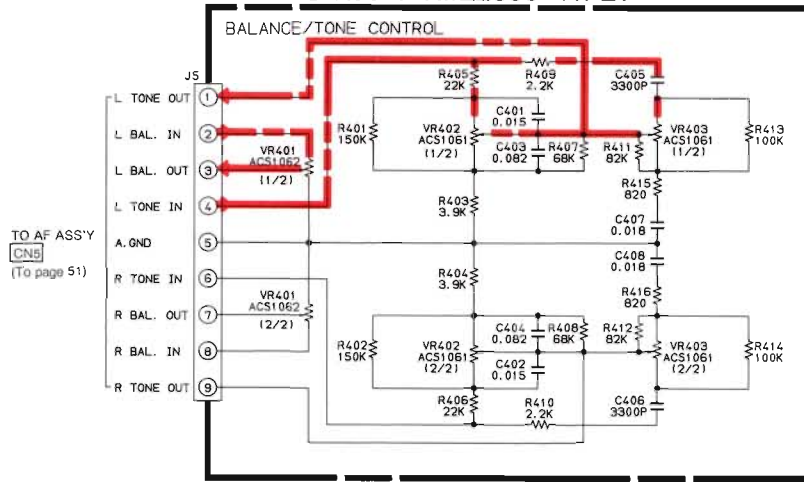

TO AF ASS'Y
CNS
(To page 51)

B

FRONT INPUT ASS'Y

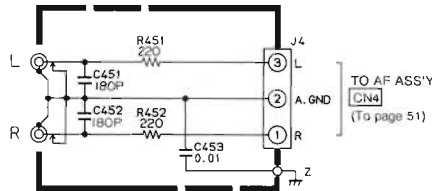

TO AF ASS'Y
CNS
(To page 51)

VOLUME DRIVE ASS'Y



ASS'Y ONLY FOR
VOLUME MECHANISM

C

C

5.3 SPECIFICATIONS

Amplifier Section

A	Rated output	
	20 Hz — 20 kHz, 0.01 % 10 k Ω	7 V
	Total harmonic distortion	
	20 Hz — 20 kHz, 1 V 10 k Ω	0.002 %
	Input terminals (sensitivity/impedance)	
	PHONO MM	2.5 mV/50 k Ω
	PHONO MC	250 μ V/100 Ω
	CD, TUNER, TAPE PLAY, LINE	150 mV/50 k Ω
	Output terminals (output level/output impedance)	
	TAPE REC	150 mV/2.2 k Ω
	PRE OUT	1 V/1 k Ω
	Frequency response	
	PHONO MM 20 Hz — 20 kHz	\pm 0.2 dB
	PHONO MC 20 Hz — 20 kHz	\pm 0.3 dB
CD, TUNER, TAPE PLAY, LINE, 1 Hz — 150 kHz	\pm $\frac{1}{3}$ dB	
Tone control (Volume at -40 dB)		
BASS	\pm 8 dB, 100 Hz	
TREBLE	\pm 8 dB, 10 kHz	
Filter		
B	SUBSONIC	17 Hz, -12 dB/oct
	MUTING	$-\infty$
	SN ratio (short-circuit, A network)	
	PHONO MM	93 dB (5 mV)
PHONO MC	76 dB (500 μ V)	
CD, TUNER, TAPE PLAY, LINE	106 dB	

Power section, other

Power requirements	a.c. 240 Volts ~, 50/60 Hz
Power consumption	30 W
External dimensions	459 (W) x 417 (D) x 163 (H) mm
Weight	10.1 kg

Accessories

Pin-plug cord	1
Operating Instructions	1
Cushion spacer	2

The specifications and design noted above are subject to change without notice, due to improvements.

C

C

5.4 PANEL FACILITIES

FRONT PANEL

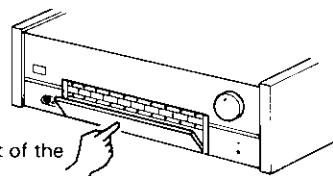
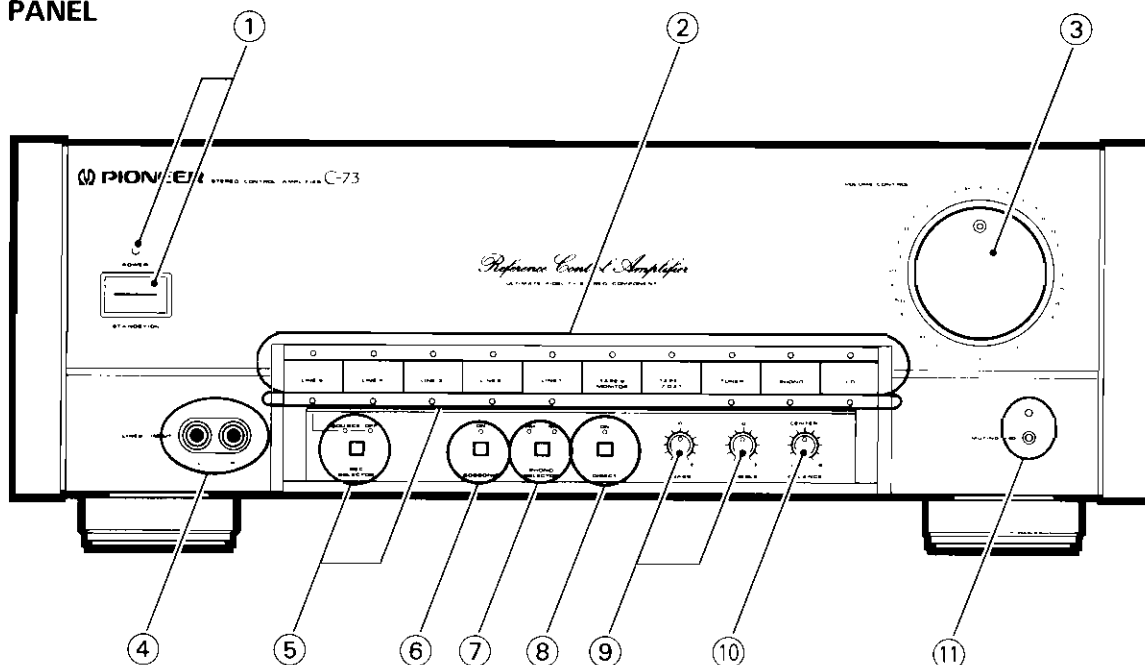

Press the center top part of the door to open.

① POWER STANDBY/ON switch/indicator

This is the switch for electric power.

ON: When set to the ON position, power is supplied and the unit becomes operational.

The POWER indicator is on.

STANDBY: When set to the STANDBY position, the main power flow is cut and the unit is no longer fully operational. A minute flow of power feeds the unit to maintain operation readiness.

When the POWER indicator is off, the unit is in STANDBY.

② Input selector buttons/indicators

Use to select the component for playback.

[CD] : For compact disc player.

[PHONO] : For turntable.

[TUNER] : For listening to FM/AM broadcasts with a tuner.

[TAPE 1/ DAT] : To use the cassette deck or DAT connected to the TAPE 1/DAT terminals.

[TAPE 2 MONITOR] : To use the cassette deck, connected to the TAPE 2 MONITOR terminals.

[LINE 1] : For components connected to LINE 1 terminal.

[LINE 2] : For components connected to LINE 2 terminal.

[LINE 3] : For components connected to LINE 3 terminal.

[LINE 4] : For components connected to LINE 4 terminal.

[LINE 5] : For components connected to LINE 5 terminal on front panel.

③ VOLUME CONTROL

Use to adjust the sound volume. At the $[-\infty]$ position, sound will not be heard, while at the $[0]$ position, sound volume will be at its maximum.

④ LINE 5 INPUT terminals

Connect to an audio component's output terminal.

⑤ REC SELECTOR button/indicators

Use to select the playback source component used when performing recording. The audio signals from the select component will be output from the output terminals. When set to SOURCE (SOURCE indicator lights), the signals selected with the input selector switch will be output.

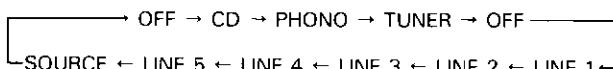

⑥ SUBSONIC button/indicator

When the button is pressed to the ON position, the indicator lights and the subsonic filter acts to cut out all frequencies below 17 Hz.

⑦ PHONO SELECTOR button/indicators

Set in accordance with the type of cartridge used on your record player (the corresponding indicator will light).

[MM]: Set here when using a moving magnet cartridge, or a high-output (1 mV or more) moving coil (MC) cartridge.

[MC]: Set here when using a moving coil cartridge.

⑧ DIRECT button/indicator

Use this to listen to the audio signal without routing it through subsonic, tone control (BASS, TREBLE), or balance control circuitry.

NOTE:

When the DIRECT button is in the ON position, the TAPE 2 MONITOR button and SUBSONIC button do not operate.

⑨ Tone controls

[BASS]: Use to adjust low frequency sounds. The central [0] indicates the standard (flat) position. When the control is rotated to the right, low-frequency sounds are augmented; when rotated to the left, low-frequency sounds are attenuated.

[TREBLE]: Use to adjust high-frequency sounds. The central [0] indicates the standard (flat) position. When the control is rotated to the right, high-frequency sounds are augmented; when rotated to the left, high-frequency sounds are attenuated.

⑩ BALANCE control

Normally leave in the center position. Use to adjust the balance of sound from right and left channels.

⑪ MUTING button/indicator

Use to temporarily cut the sound. The muting function is on when the MUTING indicator lights. Press the button again to turn the muting function off and return the sound volume to the normal level (the indicator goes out).

NOTE:

When listening at high volume levels, even if you switch MUTING ON, you will still hear a faint sound.

REAR PANEL

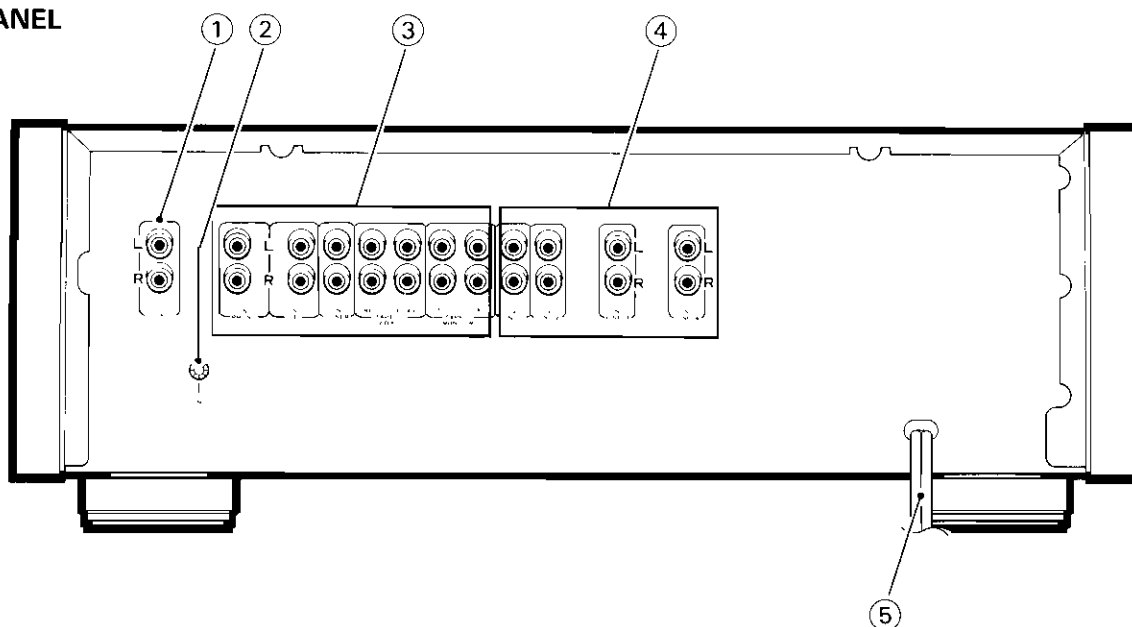

① OUTPUT terminals

Connect to the power amplifier input terminals. Adjust the output level of the signal with this unit's VOLUME CONTROL. When using with a power amplifier or surround processor without volume control capability, connect to this terminal.

② Ground (GND) terminal

Connect to the ground terminal of your turntable.

③ Audio components terminals

[PHONO] : Turntable.
[CD] : Compact disc player.
[TUNER] : FM/AM Tuner.
[TAPE 1/DAT] : Cassette deck 1 (first deck) or DAT.
PLAY : For playback (connect to the tape deck's PLAY terminals).
REC : For recording (connect to the tape deck's REC terminals).
[TAPE 2 MONITOR] : Cassette deck 2 (second deck).
PLAY : For playback. Connect to the cassette deck PLAY terminal.
REC : For recording. Connect to the cassette deck REC terminal.

④ LINE 1-4 input terminals

Connect to an audio component's output terminal.

⑤ Power cord

Connect to a household wall outlet, or the power outlet of an audio timer.



6. FOR C-73/HB TYPE

NOTES:

- Parts without part number cannot be supplied.
- The  mark found on some component parts indicates the importance of the safety factor of the part. Therefore, when replacing, be sure to use parts of identical designation.
- Parts marked by "●" are not always kept in stock. Their delivery time may be longer than usual or they may be unavailable.

CONTRAST OF MISCELLANEOUS PARTS

The C-73/HB type is the same as the C-73/HEZ type with the exception of the following sections.

Mark	Symbol & Description	Parts No.		Remarks
		C-73/HEZ type	C-73/HB type	
 	AC POWER CORD	ADG1036	ADG1041	
	FU1 FUSE (T500mA)	AEK-401	AEK-505	
	OPERATING INSTRUCTIONS (ENGLISH/GERMAN/ FRENCH/ITALIAN/DUTCH/ SWEDISH/SPANISH/ PORTUGUESE)	ARE1167	-----	
	OPERATING INSTRUCTIONS (ENGLISH)	-----	ARB1270	

7. IC INFORMATION

● PD5139A

TERMINAL FUNCTION

No.	Terminal name	I/O	P type	Function	Active
1	Vcc	–	–	+ 5V power supply	
2	GND	–	–	A/D, D/A analog GND	
3	Vref	–	–	A/D, D/A reference voltage	
4	R-SEL-OFF	O	AD	REC-SELECTOR ON/OFF	H:OFF
5	OPT2	O	N	MM/MC Switching	H:MC
6	MM/MC	O	N	MM/MC Switching (LED Drive)	H:MM
7	LOUD	O	N	LOUDNESS ON/OFF (Not used: GND)	H:OFF
8	SUBSONIC	O	N	SUBSONIC ON/OFF	H:OFF
9	DIRECT	O	N	DIRECT ON/OFF	H:OFF
10	V-ADPT	O	N	VIDEO ADPT. ON/OFF (Not used: GND)	H:OFF
11	A-ADPT	O	N	AUDIO ADPT. (TAPE2/MONITOR) ON/OFF	H:OFF
12	SR-REM	I	C	SR Remote control input	SR
13	CE2	O	N	PD0012A CE ₂ (Not used: GND)	L:ON
14	CE1	O	N	PD0012A CE ₁	L:ON
15	CE0	O	N	PD0012A CE ₀	L:ON
16	DATA	O	N	PD0012A DATA	
17	CLK	O	N	PD0012A CLK	
18	V-FUNC0	O	N	VIDEO FUNCTION control (0)**1	H/L
19	V-FUNC1	O	N	VIDEO FUNCTION control (1)**1	H/L
20	V-FUNC2	O	N	VIDEO FUNCTION control (2)**1	H/L
21	V-FUNC3	O	N	VIDEO FUNCTION control (3) (Not used : GND)	H/L
22	V-ASS'Y-ON/OFF	O	N	VIDEO ASS'Y LOCAL $\overline{\text{ON/OFF}}$ **1	L:ON
23	INT2	I	C	For SILENT operation. POWER ON signal	L:ON
24	Vol-UP	O	N	VOLUME UP output (electrically activated)	H:UP
25	Vol-DOWN	O	N	VOLUME DOWN output (electrically activated)	H:DOWN
26	INT1	I	C	For SILENT operation. POWER OFF signal	L:OFF
27	GND	–	–	0V	
28	$\overline{\text{RESET}}$	I	–	$\overline{\text{RESET}}$ input. 0V: reset at 2 μs and plus.	L:Reset
29	Xin	I	–	The 4.19MHz ceramic resonator is connected between terminals.	
30	Xout	O			
31	NC	O	C	TIMING CLOCK output (Not used: NC)	
32	Vss	–	–	0V	
33	KEYin7	I	C	Key matrix input	L:Key ON
34	KEYin6	I	C	Key matrix input	L:Key ON

No.	Terminal name	I/O	P type	Function	Active
35	KEYin5	I	C	Key matrix input	L:Key ON
36	KEYin4	I	C	Key matrix input	L:Key ON
37	KEYin3	I	C	Key matrix input	L:Key ON
38	KEYin2	I	C	Key matrix input	L:Key ON
39	KEYin1	I	C	Key matrix input	L:Key ON
40	KEYin0	I	C	Key matrix input	L:Key ON
41	V-R-SEL2	O	N	VIDEO REC-SEL control (2)*1	H/L
42	V-R-SEL1	O	N	VIDEO REC-SEL control (1)*1	H/L
43	V-R-SEL0	O	N	VIDEO REC-SEL control (0)*1	H/L
44	POWER-ON/OFF	O	N	AC primary side ON/OFF	H:OFF
45	SP-B	O	N	SPEAKER B ON/OFF (Not used: GND)	H:OFF
46	SP-A	O	N	SPEAKER A ON/OFF (Not used: GND)	H:OFF
47	FUNC-LD	O	N	FUNCTION [LD] : AUDIO control*2	L:Selects
48	FUNC-CD	O	N	FUNCTION [CD] : AUDIO control*2	L:Selects
49	V-IND-V2	O	N	FUNCTION [VIDEO2] : VIDEO-IND (Not used: GND)	L:Lights
50	V-IND-V1	O	N	FUNCTION [VIDEO] : VIDEO-IND*2	L:Lights
51	V-IND-VTR3	O	N	FUNCTION [VCR3] : VIDEO-IND (Not used: GND)	L:Lights
52	V-IND-VTR2	O	N	FUNCTION [VCR2] : VIDEO-IND*2	L:Lights
53	V-IND-VTR1	O	N	FUNCTION [VCR1] : VIDEO-IND*2	L:Lights
54	V-IND-TV	O	N	FUNCTION [TV] : VIDEO-IND*2	L:Lights
55	V-IND-LD	O	N	FUNCTION [LD] : VIDEO-IND*2	L:Lights
56	REC-MUTE	O	N	REC MUTE CONTROL	L:ON
57	MUTE-IND	O	C	MUTE IND	L:Lights
58	MUTE-CONT	O	C	MUTE CONTROL	H:ON
59	J.KU/HE.HB	O	C	Destination switching strobe OUT*3	L:OUT
60	KEYout4	O	C	Key strobe OUT4	L:OUT
61	KEYout3	O	C	Key strobe OUT3	L:OUT
62	KEYout2	O	C	Key strobe OUT2	L:OUT
63	KEYout1	O	C	Key strobe OUT1	L:OUT
64	KEYout0	O	C	Key strobe OUT0	L:OUT

P type (Port type)

- C: CMOS input or CMOS output
- N: Nch open drain output
- AN: 8-bit A/D analog input

VIDEO Function Control

Pin 18	Pin 19	Pin 20	Pin 21	Function
H	H	H	L	TV
L	H	H	L	LD
H	L	H	L	VIDEO
L	L	H	L	VCR1
H	H	L	L	VCR2

VIDEO REC-SEL Control

Pin 43	Pin 42	Pin 41	Function
H	H	H	TV
L	H	H	LD
H	L	H	VIDEO
L	L	H	VCR1
H	H	L	VCR2

*1: Used only for C-72.

*2: Function names are different between C-72 and C-73 as follows. The names shown in above tables are in accordance with C-72.

Functions of C-72	Functions of C-73
CD	CD
PHONO	PHONO
TUNER	TUNER
TAPE1/DAT	TAPE1/DAT
TAPE2/MONITOR	TAPE2/MONITOR
LD	LINE1
TV/AUX	LINE2
VCR1	LINE3
VCR2	LINE4
VIDEO	LINE5

*3: Diode matrix

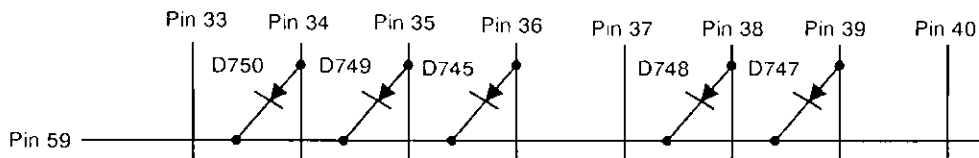

By connecting (C) or disconnecting (NC) D745 and D747-D750, switching of below-mentioned optional functions is available.

D750: Destination switching

(C): For destinations corresponding to only AUDIO functions (C-73/HEZ and HB types.)

(NC): For destinations corresponding to AUDIO/VIDEO functions (C-70/J, C-72/KU/CA and SD types).

D749 and D745: Switching of AUDIO functions, and switching of common functions to AUDIO/VIDEO.

Type	D749	D745	CD	PHONO	TUNER	TAPE1	LINE 1 LD	LINE 2 TV	LINE 3 VCR1	LINE 4 VCR2	LINE5 VIDEO
C-72/KU/CA and SD types	C	NC	**1	**1	**1	**1	5	6	7,8	9	10
C-73/HEZ and HB types	NC	C	1	2	3	4	5	6	7	8	9

Note: Figures in the tables show the cyclic order.

**1: D747 and D748: Switching of AUDIO functions (Available only for destinations corresponding to AUDIO/VIDEO).

D748	D747	CD	PHONO	TUNER	TAPE1
C	C	1	2	3	4

Note: Figures in the tables show the cyclic order.

● PD0012A (IC702)

No.	Terminal name	I/O	P type	Function	Active
1	DATA	–	–	DATA input	
2	CLK	–	–	CLOCK input	
3	CEO	–	–	CHIP ENABLE input	
4	FUNC PHONO	O	N	FUNCTION [PHONO] : AUDIO control*1	L:Selects
5	FUNC TUNER	O	N	FUNCTION [TUNER] : AUDIO control*1	L:Selects
6	FUNC DAT1	O	N	FUNCTION [DAT-1] : AUDIO control (Not used: GND)	L:Selects
7	FUNC DAT2	O	N	FUNCTION [DAT-2] : AUDIO control (Not used: GND)	L:Selects
8	FUNC TAPE	O	N	FUNCTION [TAPE1] : AUDIO control*1	L:Selects
9	GND	–	–	GND	
10	FUNC AUX1	O	N	FUNCTION [AUX-1] : AUDIO control (Not used: GND)	L:Selects
11	FUNC TV	O	N	FUNCTION [TV] : AUDIO control*1	L:Selects
12	FUNC VTR1	O	N	FUNCTION [VCR-1] : AUDIO control*1	L:Selects
13	FUNC VTR2	O	N	FUNCTION [VCR-2] : AUDIO control*1	L:Selects
14	FUNC VTR3	O	N	FUNCTION [VCR-3] : AUDIO control (Not used: GND)	L:Selects
15	FUNC V1	O	N	FUNCTION [VIDEO] : AUDIO control*1	L:Selects
16	FUNC V2	O	N	FUNCTION [VIDEO2] : AUDIO control (Not used: GND)	L:Selects
17	RESET	–	–	RESET input	
18	+5V	–	–	+5V power supply	

NOTE: For P type (Port type), refer to PD5139A.

*1: Refer to *2 of PD5139A.

● PD0012A (IC703)

No.	Terminal name	I/O	P type	Function	Active
1	DATA	–	–	DATA input	
2	CLK	–	–	CLOCK input	
3	CE1	–	–	CHIP ENABLE input	
4	R-SEL PHONO	O	N	REC-SEL [PHONO] : AUDIO control*1	L:Selects
5	R-SEL CD	O	N	REC-SEL [CD] : AUDIO control*1	L:Selects
6	R-SEL TUNER	O	N	REC-SEL [TUNER] : AUDIO control*1	L:Selects
7	R-SEL DAT1	O	N	REC-SEL [DAT-1] : AUDIO control (Not used: GND)	L:Selects
8	R-SEL TAPE	O	N	REC-SEL [TAPE1] : AUDIO control*1	L:Selects
9	GND	–	–	GND	
10	R-SEL LD	O	N	REC-SEL [LD] : AUDIO control*1	L:Selects
11	R-SEL TV	O	N	REC-SEL [TV] : AUDIO control*1	L:Selects
12	R-SEL VTR1	O	N	REC-SEL [VCR-1] : AUDIO control*1	L:Selects
13	R-SEL VTR2	O	N	REC-SEL [VCR-2] : AUDIO control*1	L:Selects
14	R-SEL V1	O	N	REC-SEL [VIDEO] : AUDIO control*1	L:Selects
15	R-SEL OFF	O	N	REC-SEL [OFF] IND	L:Selects
16	R-SEL SOURCE	O	N	REC-SEL [SOURCE] control	L:Selects
17	RESET	–	–	RESET input	
18	+5V	–	–	+5V power supply	

NOTE: For P type (Port type), refer to PD5139A.

*1: Refer to *2 of PD5139A.