

Pioneer

Service Manual

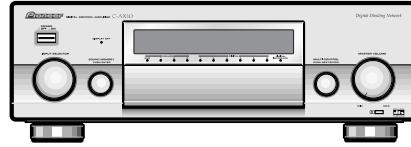

ORDER NO.
RRV2327

DIGITAL CONTROL AMPLIFIER

C-AX10

THIS MANUAL IS APPLICABLE TO THE FOLLOWING MODEL(S) AND TYPE(S).

Type	Model	Power Requirement	Remarks
	C-AX10		
KU/CA	○	AC120V	
NY	○	AC230V	

CONTENTS

1. SAFETY INFORMATION	2	7.1.3 POWER ON SEQUENCE	86
2. EXPLODED VIEWS AND PARTS LIST	3	7.1.4 DISASSEMBLY	90
3. BLOCK DIAGRAM AND SCHEMATIC DIAGRAM	10	7.1.5 PCB LAYOUT	95
4. PCB CONNECTION DIAGRAM	50	7.2 PARTS	96
5. PCB PARTS LIST	76	7.2.1 IC	96
6. ADJUSTMENT	83	7.2.2 DISPLAY	109
7. GENERAL INFORMATION	84	7.3 REMOTE CONTROL UNIT	110
7.1 DIAGNOSIS	84	8. PANEL FACILITIES AND SPECIFICATIONS	113
7.1.1 TEST MODE	84		
7.1.2 TROUBLESHOOTING	85		

1. SAFETY INFORMATION

This service manual is intended for qualified service technicians ; it is not meant for the casual do-it-yourselfer. Qualified technicians have the necessary test equipment and tools, and have been trained to properly and safely repair complex products such as those covered by this manual. Improperly performed repairs can adversely affect the safety and reliability of the product and may void the warranty. If you are not qualified to perform the repair of this product properly and safely, you should not risk trying to do so and refer the repair to a qualified service technician.



WARNING

This product contains lead in solder and certain electrical parts contain chemicals which are known to the state of California to cause cancer, birth defects or other reproductive harm.

Health & Safety Code Section 25249.6 – Proposition 65



NOTICE

(FOR CANADIAN MODEL ONLY)

Fuse symbols  (fast operating fuse) and/or  (slow operating fuse) on PCB indicate that replacement parts must be of identical designation.

REMARQUE

(POUR MODÈLE CANADIEN SEULEMENT)

Les symboles de fusible  (fusible de type rapide) et/ou  (fusible de type lent) sur CCI indiquent que les pièces de remplacement doivent avoir la même désignation.

(FOR USA MODEL ONLY)

1. SAFETY PRECAUTIONS

The following check should be performed for the continued protection of the customer and service technician.

LEAKAGE CURRENT CHECK

Measure leakage current to a known earth ground (water pipe, conduit, etc.) by connecting a leakage current tester such as Simpson Model 229-2 or equivalent between the earth ground and all exposed metal parts of the appliance (input/output terminals, screwheads, metal overlays, control shaft, etc.). Plug the AC line cord of the appliance directly into a 120V AC 60Hz outlet and turn the AC power switch on. Any current measured must not exceed 0.5mA.

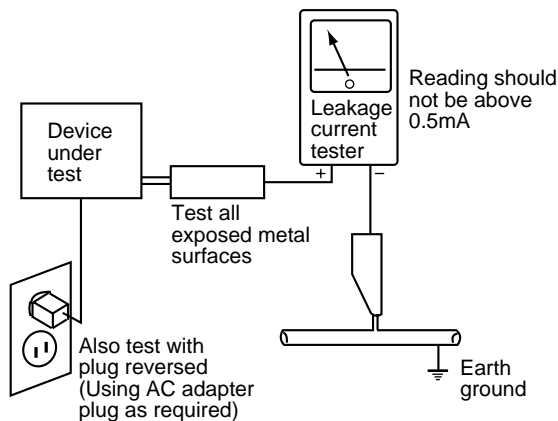

AC Leakage Test

ANY MEASUREMENTS NOT WITHIN THE LIMITS OUTLINED ABOVE ARE INDICATIVE OF A POTENTIAL SHOCK HAZARD AND MUST BE CORRECTED BEFORE RETURNING THE APPLIANCE TO THE CUSTOMER.

2. PRODUCT SAFETY NOTICE

Many electrical and mechanical parts in the appliance have special safety related characteristics. These are often not evident from visual inspection nor the protection afforded by them necessarily can be obtained by using replacement components rated for voltage, wattage, etc. Replacement parts which have these special safety characteristics are identified in this Service Manual.

Electrical components having such features are identified by marking with a Δ on the schematics and on the parts list in this Service Manual.

The use of a substitute replacement component which does not have the same safety characteristics as the PIONEER recommended replacement one, shown in the parts list in this Service Manual, may create shock, fire, or other hazards.

Product Safety is continuously under review and new instructions are issued from time to time. For the latest information, always consult the current PIONEER Service Manual. A subscription to, or additional copies of, PIONEER Service Manual may be obtained at a nominal charge from PIONEER.

2. EXPLODED VIEWS AND PARTS LIST

- NOTES:
- Parts marked by "NSP" are generally unavailable because they are not in our Master Spare Parts List.
 - The Δ mark found on some component parts indicates the importance of the safety factor of the part. Therefore, when replacing, be sure to use parts of identical designation.
 - Screws adjacent to \blacktriangledown mark on the product are used for disassembly.

2.1 PACKING

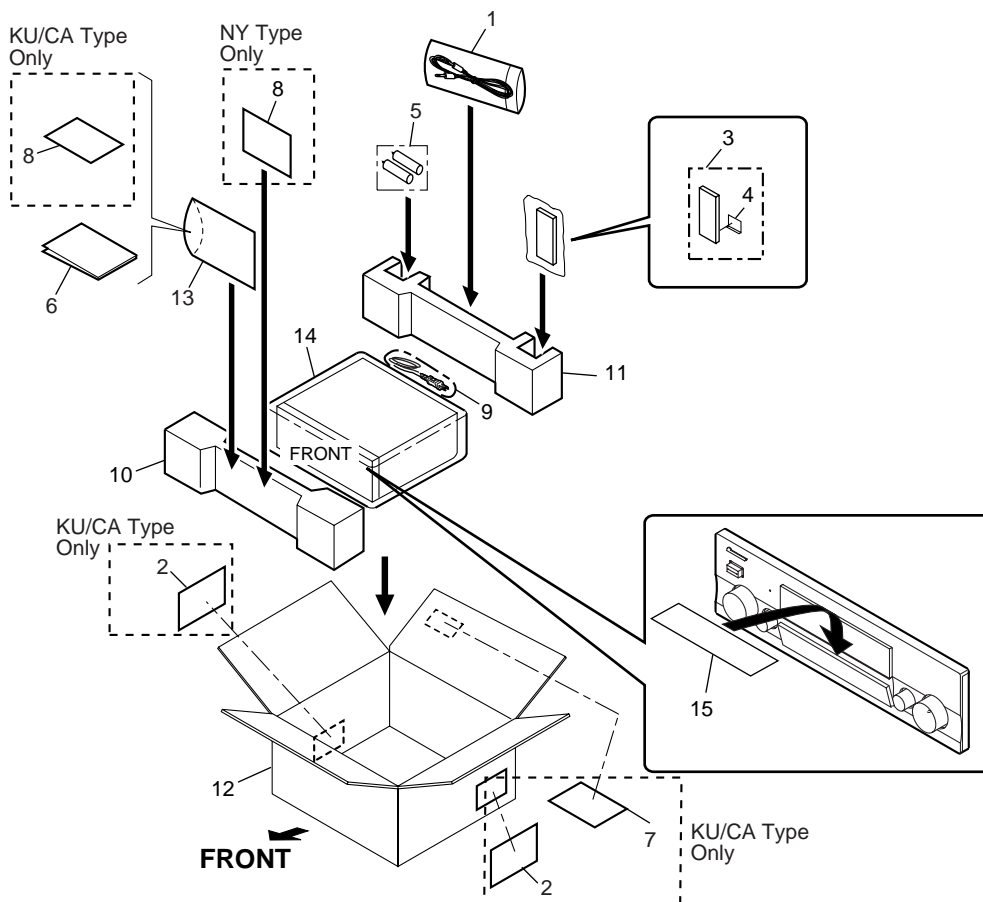

(1) PACKING PARTS LIST

Mark	No.	Description	Part No.	Mark	No.	Description	Part No.
	1	PDIF Connection Cable	ADE1087		11	Rear Pad	AHA9017
	2	Recycle Label	See Contrast table (2)		12	Packing Case	AHD7858
	3	Remote Control Unit (CU-C005)	AXD7198	NSP	13	Polyethylene Bag	AHG-117
	4	Battery Cover	AZN7813		14	Packing Sheet	AHG7008
NSP	5	Dry Cell Battery (R6P,AA)	VEM-013		15	Door Sheet	AHG7067
	6	Operating Instructions (English)	ARB7221				
	7	POS Code Label	See Contrast table (2)				
NSP	8	Warranty Card	See Contrast table (2)				
	9	Mirror Mat Bag	VHL1004				
	10	Front Pad	AHA9016				

(2) CONTRAST TABLE

C-AX10/KU/CA and NY are constructed the same except for the following :

Mark	No.	Symbol and Description	Part No.		Remarks
			KU/CA Type	NY Type	
NSP	2	Recycle Label	ARW7091	Not used	
	7	POS Code Label	ARW7090	Not used	
	8	Warranty Card	ARY7045	ARY7022	

2.2 EXTERIOR

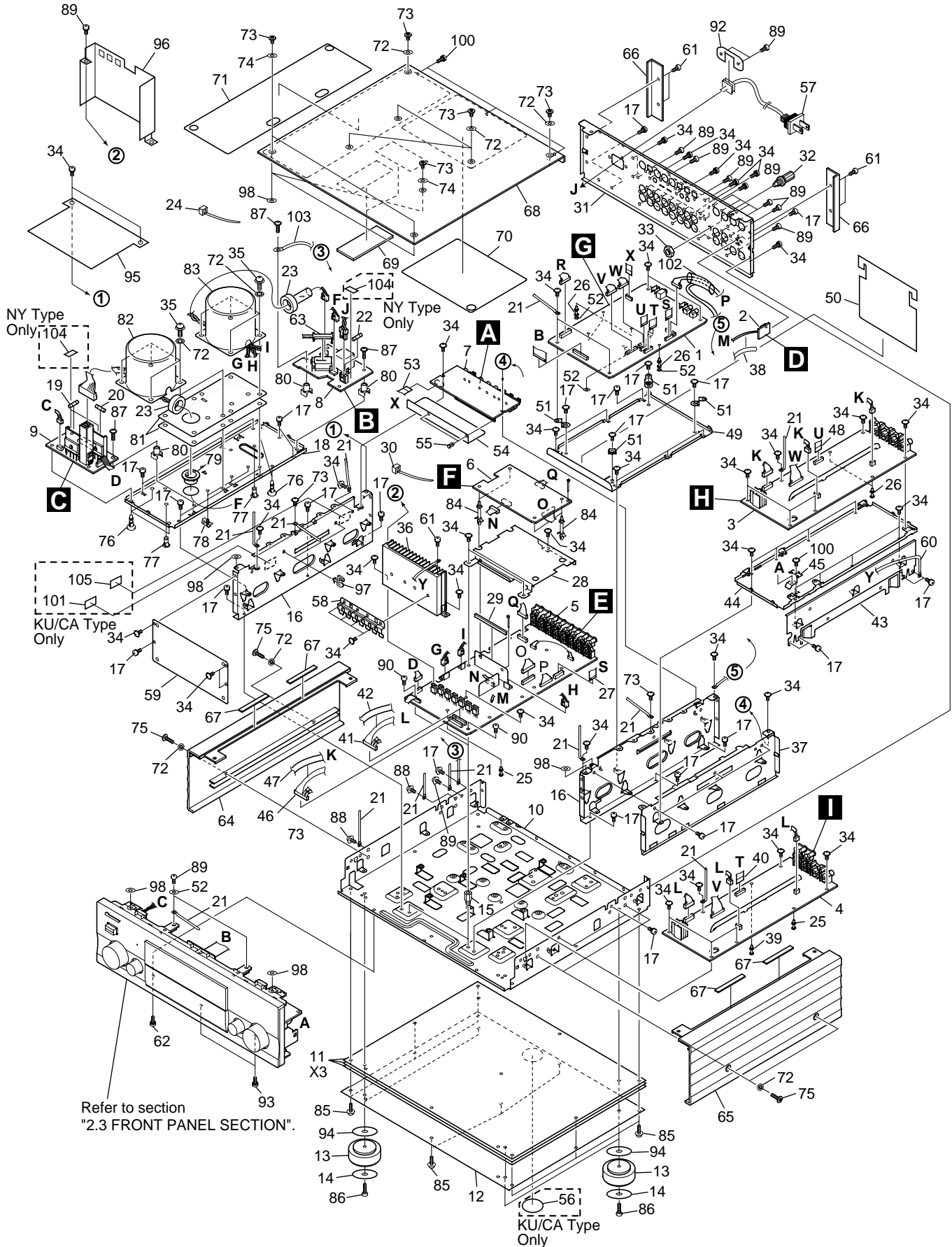

(1) EXTERIOR PARTS LIST

Mark	No.	Description	Part No.	Mark	No.	Description	Part No.
NSP	1	DSP Assy	See Contrast table (2)	NSP	51	PCB Base	RNE1849
	2	SG Assy	AWX7444		52	Washer	ABE-053
	3	AUDIO A Assy	AWX7530		53	J1401 14P FFC/30V (DIGITAL I/O CN1401↔DSP CN1601)	ADD7130
	4	AUDIO B Assy	AWX7531		54	Shield Plate C	AMR7270
	5	FRAD Assy	AWX7532		55	Nylon Rivet	AEC-525
	6	CRAD Assy	AWX7535		56	UL Caution Card	See Contrast table (2)
	7	DIGITAL I/O Assy	AWX7533	△	57	Power Cord	See Contrast table (2)
	8	AC Assy	See Contrast table (2)		58	Transistor Holder	ANG9105
	9	PS Assy	See Contrast table (2)	NSP	59	Subplate	ANG7279
NSP	10	Under Base	ANA9010		60	Earth Lead Unit	ADX7326
NSP	11	Bottom Plate	PNA2376		61	Screw	ABA7017
NSP	12	Bottom Plate B	ANF7021		62	Screw	ABA1208
	13	Insulator	ANL7013		63	FLEX SW Wire	ADH7021
	14	Stopper	AEC7224		64	Side Alum. L	AAH7040
	15	PCB Support	AEC9079		65	Side Alum. R	AAH7041
	16	Side Wall	ANG9104		66	Rear Mole	AAH7044
	17	Screw	ABA1207		67	Dump Rubber	VEB1172
	18	Subchassis B2	ANA9013		68	Top Plate	AAH7039
△	19	FU201 Fuse (4A)	See Contrast table (2)	NSP	69	Stabilizer B	AMR7278
△	20	FU202 Fuse (4A)	See Contrast table (2)		70	Shield Plate F	AMR7297
	21	Cord Holder	RNH1005		71	Shield Plate D	AMR7288
△	22	FU101 Fuse (4A)	See Contrast table (2)		72	Washer	WG40FCC
	23	Ferrite Core	ATH7008		73	SH Screw	PBA1049
NSP	24	Binder	ZCA-T30L		74	Washer	ABF7008
NSP	25	Card Spacer	AEC7081		75	Screw	ABA7006
NSP	26	Card Spacer	REC1156		76	Locking Card Spacer	DEC1908
	27	J1202 16P FFC/30V (FRAD CN1201↔DSP CN2101)	ADD7131	NSP	77	PCB Holder	AEC7057
	28	Shield Plate I	AMR7322		78	Clamper	DEC2007
NSP	29	Edging E	PEC1008	NSP	79	Bushing 19	AEC7206
NSP	30	Binder	ZCA-BK1	NSP	80	PCB Mold	AMR1525
	31	Rear Panel	See Contrast table (2)	NSP	81	Subplate	ANG7278
	32	Earth Terminal with Knob	AKE-046	△	82	T301 Power Trans. (Digital)	See Contrast table (2)
	33	Nut	NK70FCU	△	83	T401 Power Trans. (Audio)	See Contrast table (2)
	34	Screw	ABA1011	NSP	84	PCB Support	REC1248
	35	Screw	ABA1014		85	Screw	IBZ30P120FCC
NSP	36	Heat Sink Assy	ANH7125		86	Screw	ABA1022
	37	Side Support C	ANK9027		87	Screw	IBZ30P180FCC
	38	Shrink Shield (AL)	ADM7002		88	Screw	IBZ40P060FCC
NSP	39	PCB Spacer (3 × 8)	AEC1371		89	Screw	BBZ30P080FCC
	40	J1001 17P FFC/30V (AUDIO B CN1001↔DSP CN2103)	ADD7132		90	Screw	BMZ30P060FCU
	41	J1003 Connector Assy 11P (FRAD CN404↔AUDIO B CN1002, CN1003, CN1004)	ADX7274		91	Screw	BBZ30P060FCC
	42	Shrink Shield (AL)	ADM7004		92	Power Cord Spacer	ANG1153
	43	Side Frame A	VNE2181		93	Screw	ABA1050
	44	Subchassis T2	ANA9014		94	Foot Spacer	AMR7283
	45	PCB Holder	ANG9106		95	Shield Plate H	AMR7309
	46	J903 Connector Assy 11P (FRAD CN403↔AUDIO A CN902, CN903, CN904)	ADX7272		96	Shield Plate G	AMR7308
	47	Shrink Shield (AL)	ADM7003		97	Cord Clamp S	DEC1574
	48	J901 15P FFC/30V (AUDIO A CN901↔DSP CN2102)	ADD7133		98	Washer	AED7043
	49	Main Shield	ANG9103		99	••••	
NSP	50	Shield Plate E	AMR7290		100	Screw	BBT30P080FCC
					101	Fuse Caution Label	See Contrast table (2)
				NSP	102	Shield Tube	VDM1004
				NSP △	103	Earth Lead Unit	PDF1150
				NSP	104	Fuse Label	See Contrast table (2)
					105	65 Label	See Contrast table (2)

(2) CONTRAST TABLE

C-AX10/KU/CA and NY are constructed the same except for the following :

Mark	No.	Symbol and Description	Part No.		Remarks
			KU/CA Type	NY Type	
	1	DSP Assy	AWK7589	AWK7590	
	8	AC Assy	AWX7298	AWX7536	
	9	PS Assy	AWX7299	AWX7537	
△	19	FU201 Fuse (4A)	VEK1023	REK-106	
△	20	FU202 Fuse (4A)	VEK1023	REK-106	
△	22	FU101 Fuse (4A)	VEK1023	REK-106	
	31	Rear Panel	ANC7900	ANC7899	
	56	UL Caution Card	AAX-313	Not used	
△	57	Power Cord	ADG7028	ADG7029	
△	82	T301 Power Trans. (Digital)	ATS7274	ATS7276	
△	83	T401 Power Trans. (Audio)	ATS7273	ATS7275	
	101	Fuse Caution Label	ARW7089	Not used	
NSP	104	Fuse Label	Not used	AAX1589	
	105	65 Label	ARW7050	Not used	

2.3 FRONT PANEL SECTION

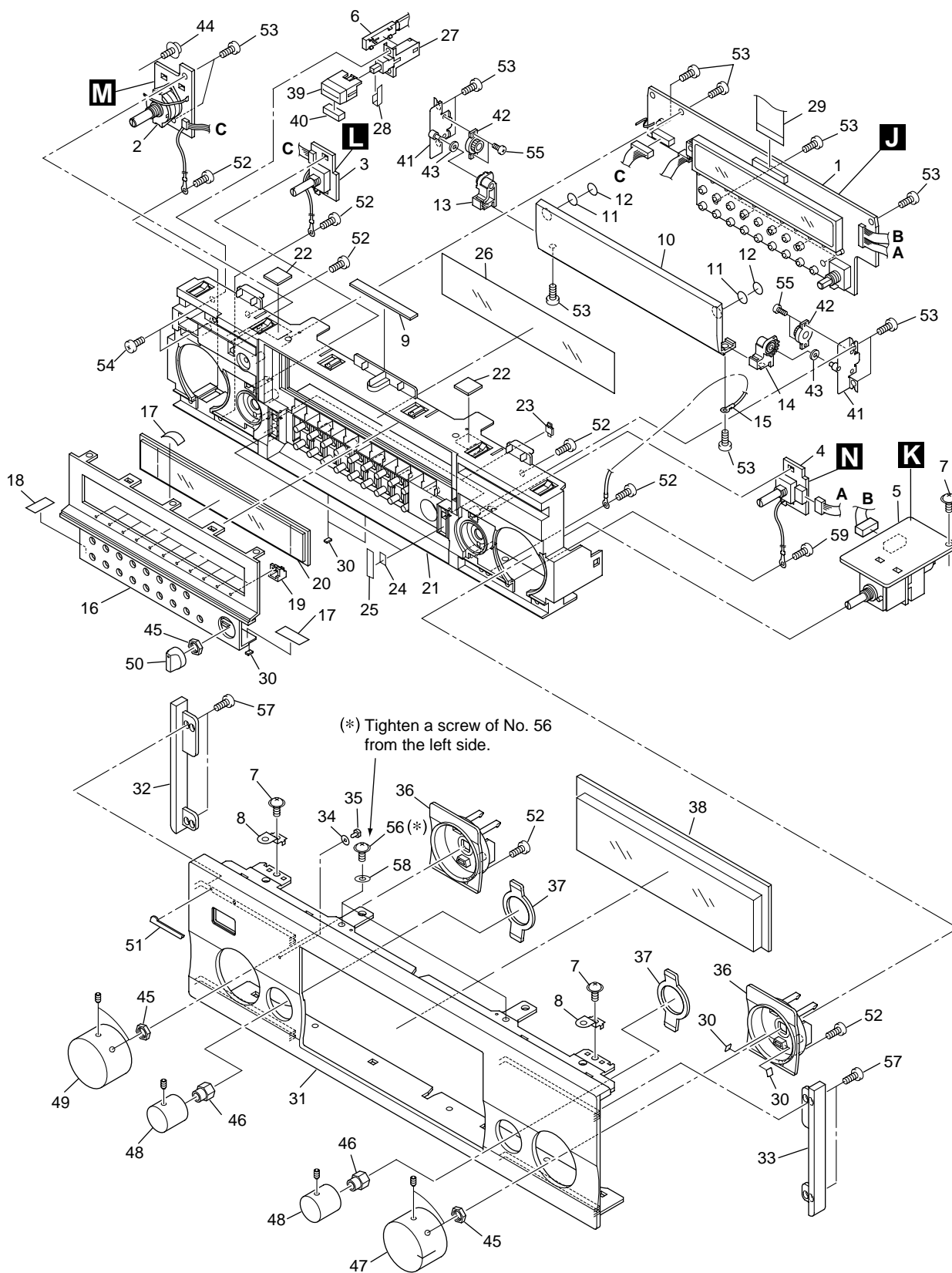

● FRONT PANEL SECTION PARTS LIST

Mark	No.	Description	Part No.	Mark	No.	Description	Part No.
	1	DISPLAY Assy	AWX7305	NSP	30	Stopper Rubber	AEB1325
	2	INPUT SW Assy	AWX7332		31	Front Panel	ANB7225
	3	ENC A Assy	AWX7303		32	Side Panel L	AAH7042
	4	ENC B Assy	AWX7304		33	Side Panel R	AAH7043
	5	VOLUME Assy	AWX7302	NSP	34	Spacer	PNM1135
	6	FLEX SW Wire	ADH7021		35	LED Lens	VNK4400
	7	Screw	ABA1011		36	Escutcheon L	AMR9201
	8	Top Stay	VNE2139		37	Escutcheon S	AMR9202
	9	Dump Rubber	VEB1172		38	FL Panel L	AAK9051
	10	Door Panel	ANB7190		39	Power Button	VNK4159
	11	Door Yoke	ANB7187		40	Block	ANL7015
	12	Door Cushion	AED9014		41	Door Axis Metal Assy	ANG9100
	13	Door Hinge L	AMR9199		42	Dumper Assy	AXA9013
	14	Door Hinge R	AMR9200		43	Washer	ABF7007
NSP	15	Earth Lead	ADH7022		44	Screw	ABA1005
	16	Inner Panel	ANB7226		45	Nut	NK90FCU
NSP	17	Spacer Film A	AEC7255		46	Bearing	ANL7014
NSP	18	Spacer Film B	AEC7256		47	Rotary Knob L	AAB7202
	19	Lens	AAK9050		48	Rotary Knob M	AAB7203
	20	FL Panel S	AAK9052		49	Rotary Knob L	AAB7204
	21	Panel Base	AMB9021		50	Rotary Knob S	AAB7200
NSP	22	Rubber Spacer	AEB7182		51	PIONEER Badge G	PAN1377
	23	Magnet	AMF7004		52	Screw	BBZ30P080FCC
NSP	24	Spacer Film C	AEC7257		53	Screw	BPZ30P080FMC
	25	Magnet Cover	AAK9045		54	Screw	PMZ30P080FMC
	26	FL Filter	AEC9078		55	Screw	PSZ20P060FMC
	27	Function Switch (POWER)	PSG1011		56	Screw	IPZ30P100FMC
NSP	28	Tape	PNM1249		57	Screw	ABA7017
	29	J2201 28P FFC/300V (DISPLAY CN2201↔DSP CN2108)	ADD7156		58	Washer	AED7043
					59	Screw	BBT30P080FCC

3. BLOCK DIAGRAM AND SCHEMATIC DIAGRAM

3.1 BLOCK DIAGRAM

3.1.1 I/O BLOCK

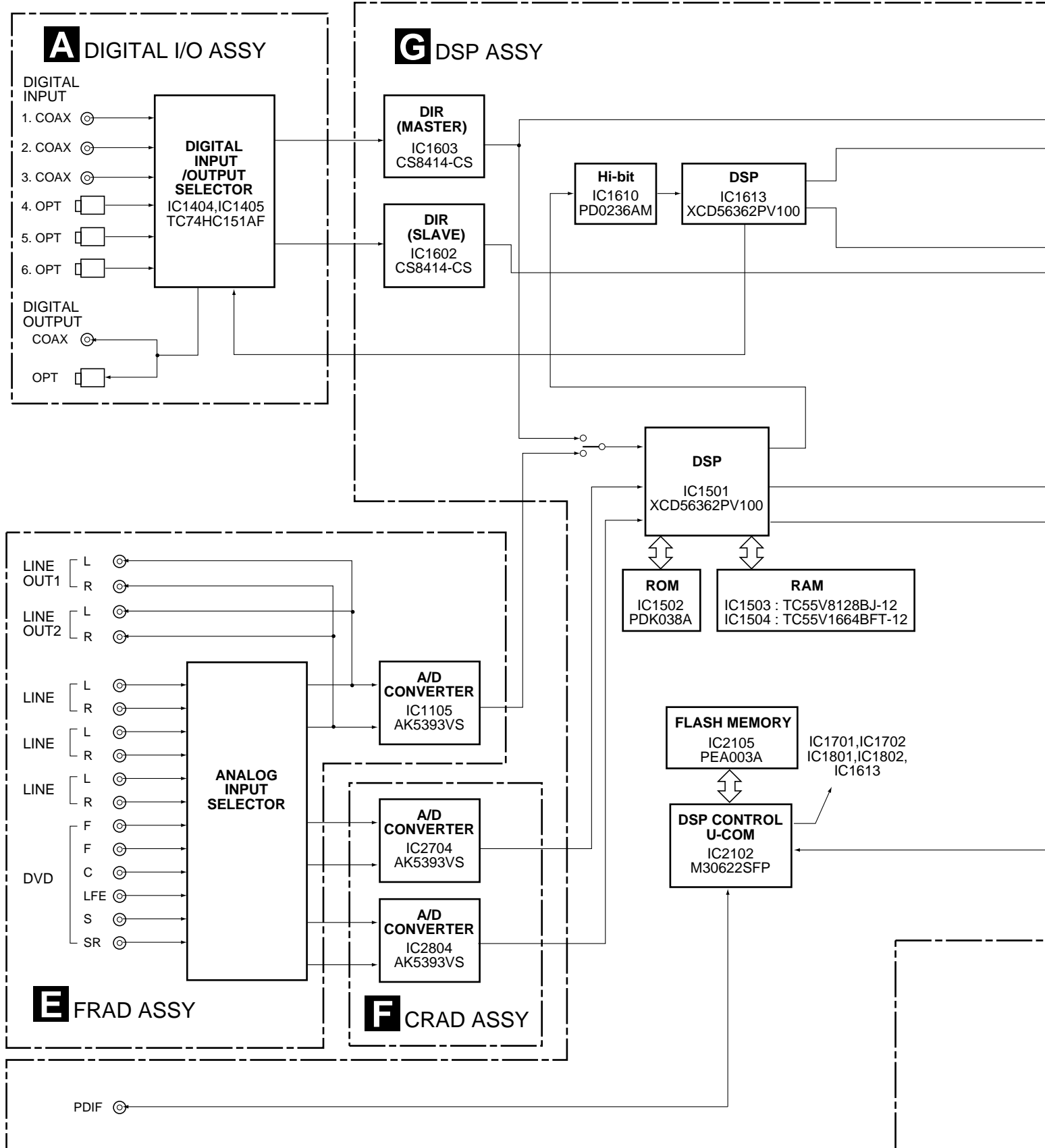

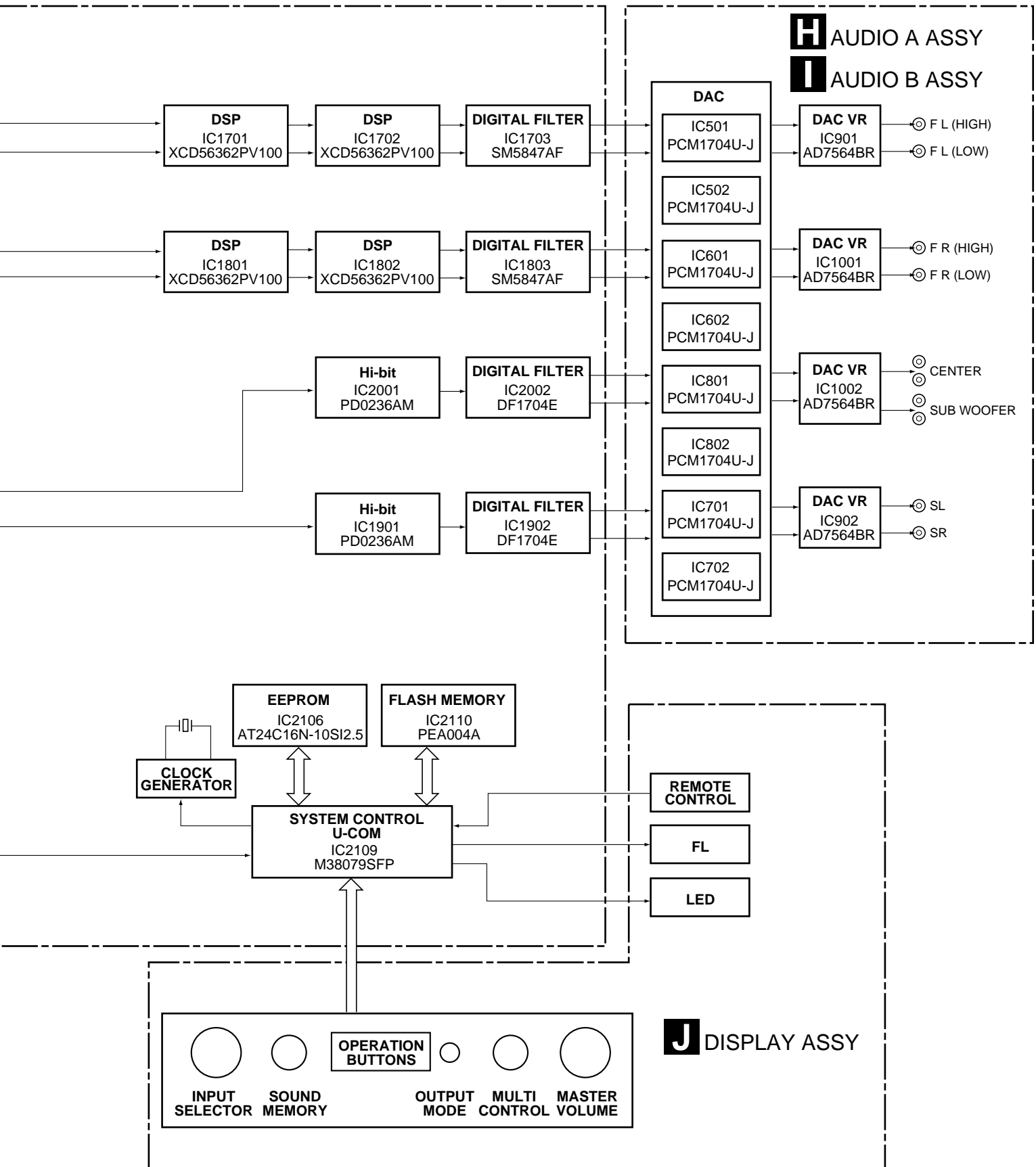

3.1.2 POWER SUPPLY BLOCK

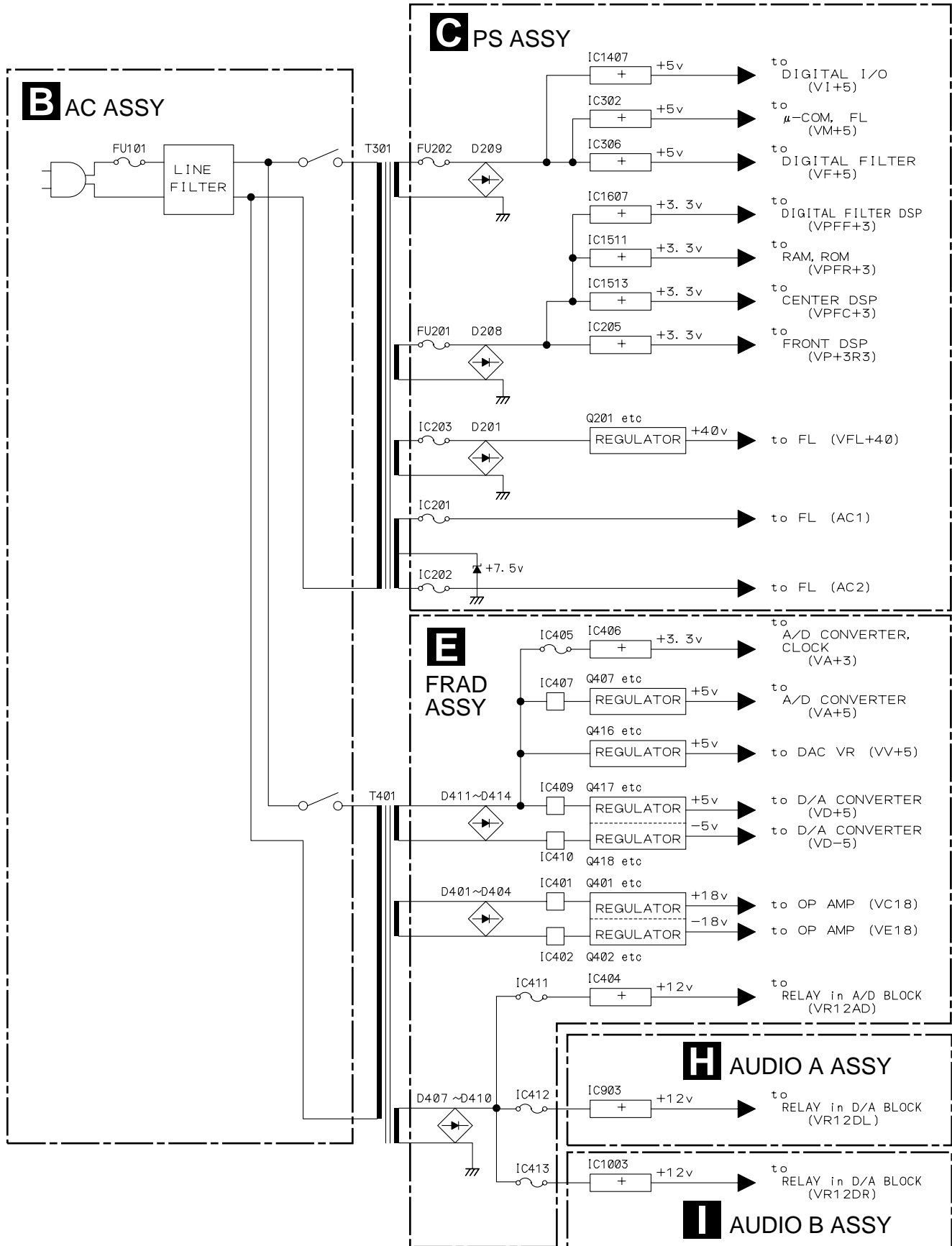

3.1.3 A/D BLOCK

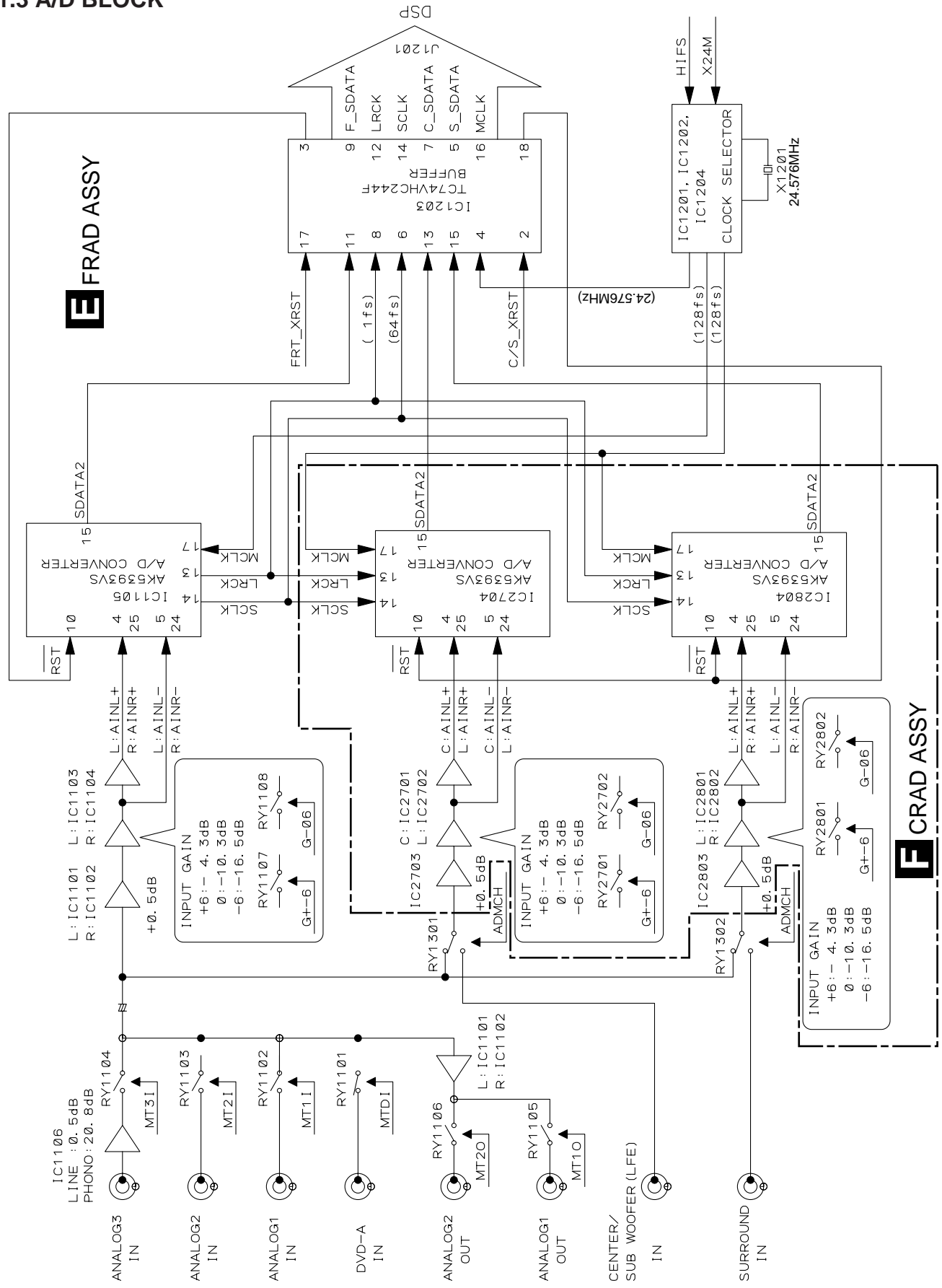

A
B
C
D

3.1.4 D/A BLOCK (AUDIO A ASSY)

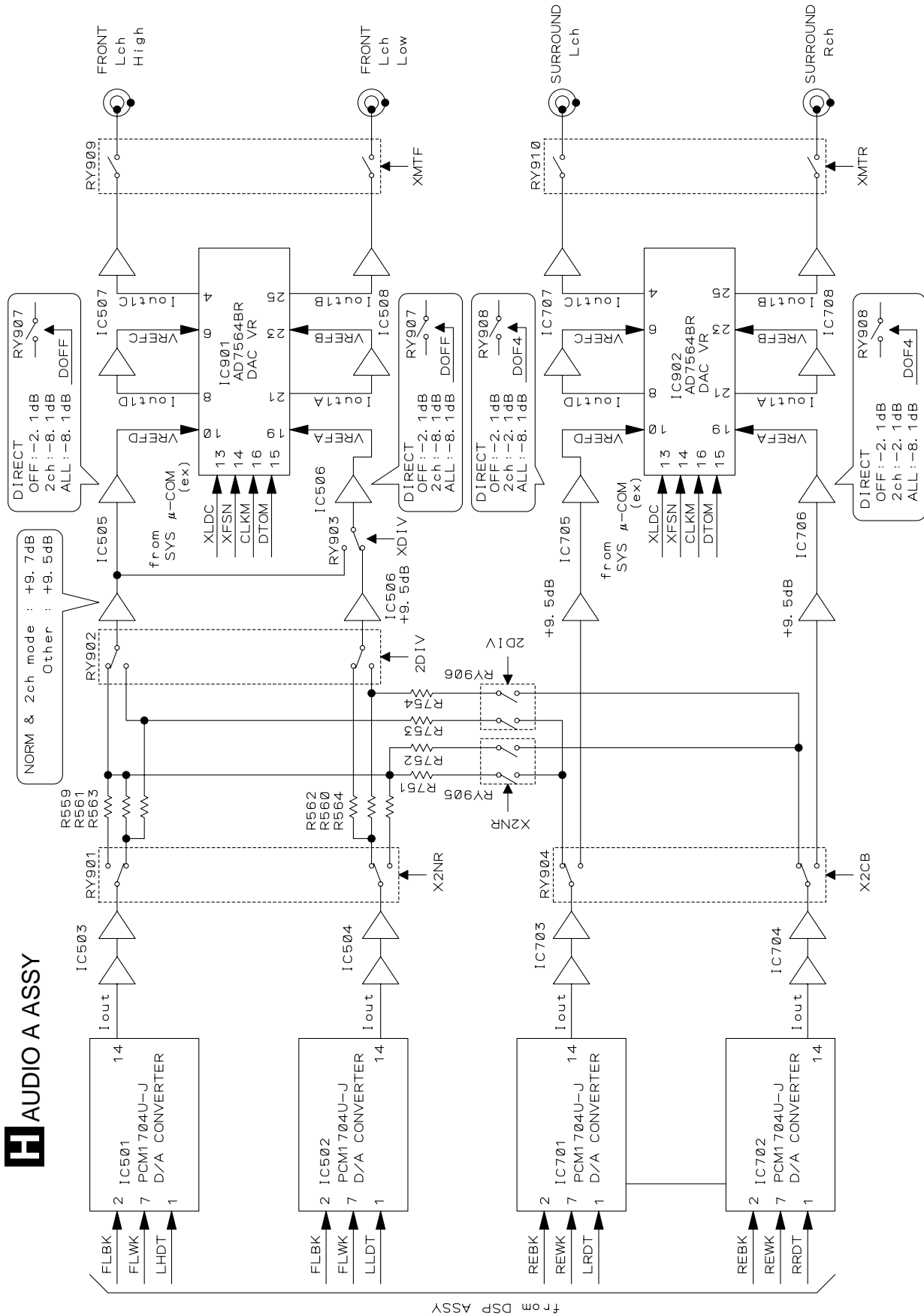

3.1.5 D/A BLOCK (AUDIO B ASSY)

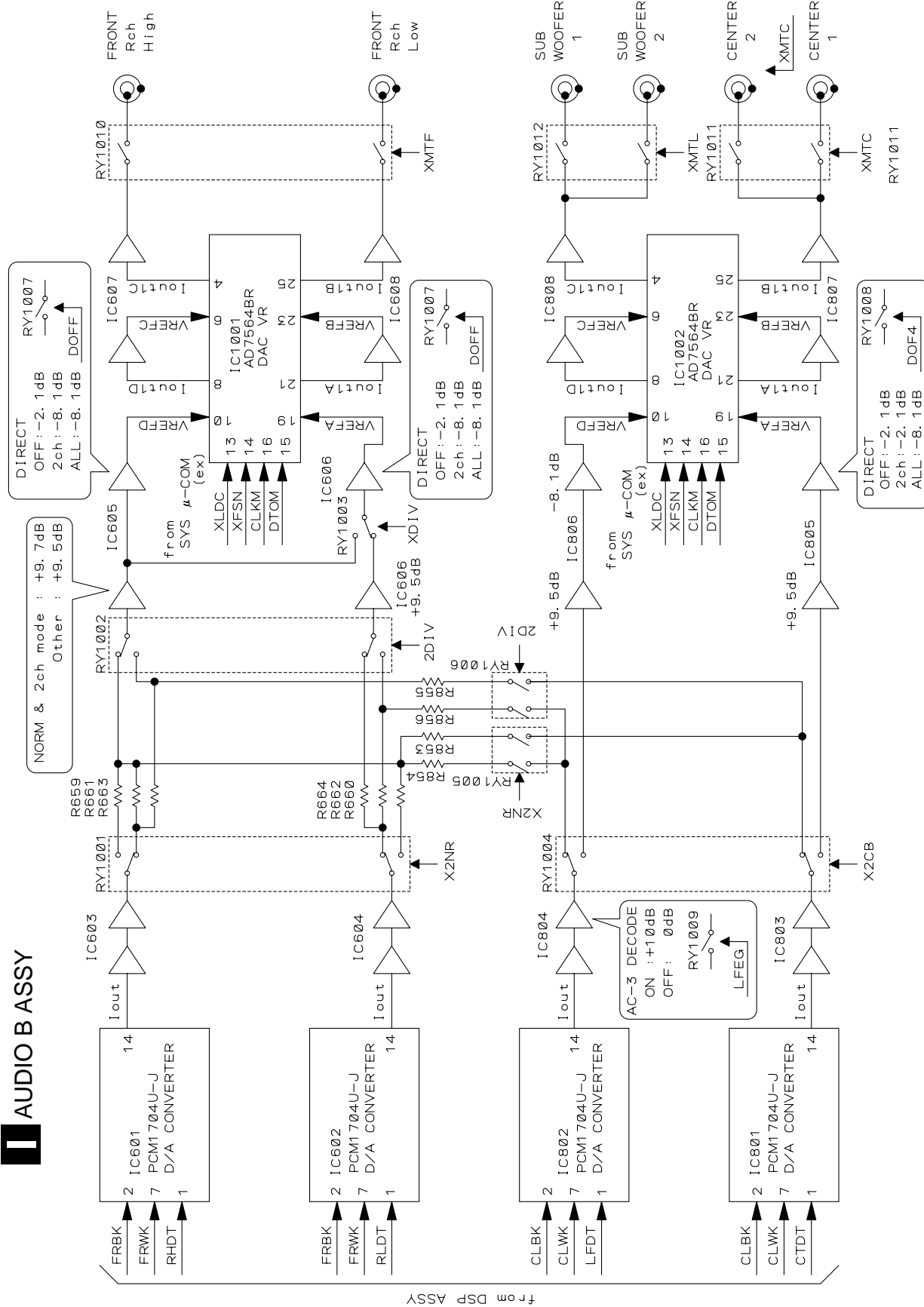

AUDIO B ASSY

from DSP ASSY

A
B
C
D

1
1
2
3
4

2
2
3
4

3
3
4

4
4

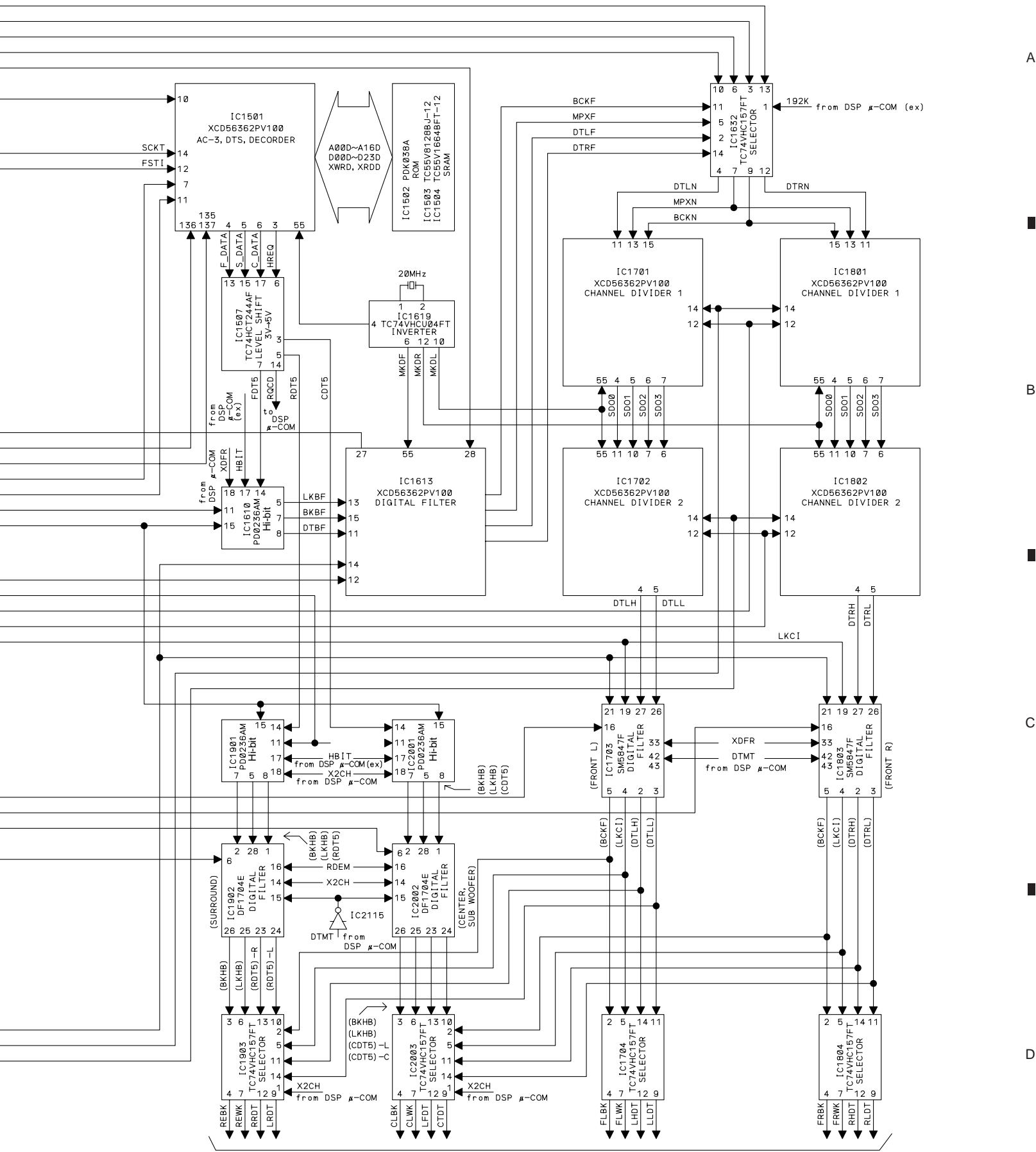

to D/A SECTION

A
B
C
D

3.1.7 μ-COM PORT BLOCK

A

B

C

D

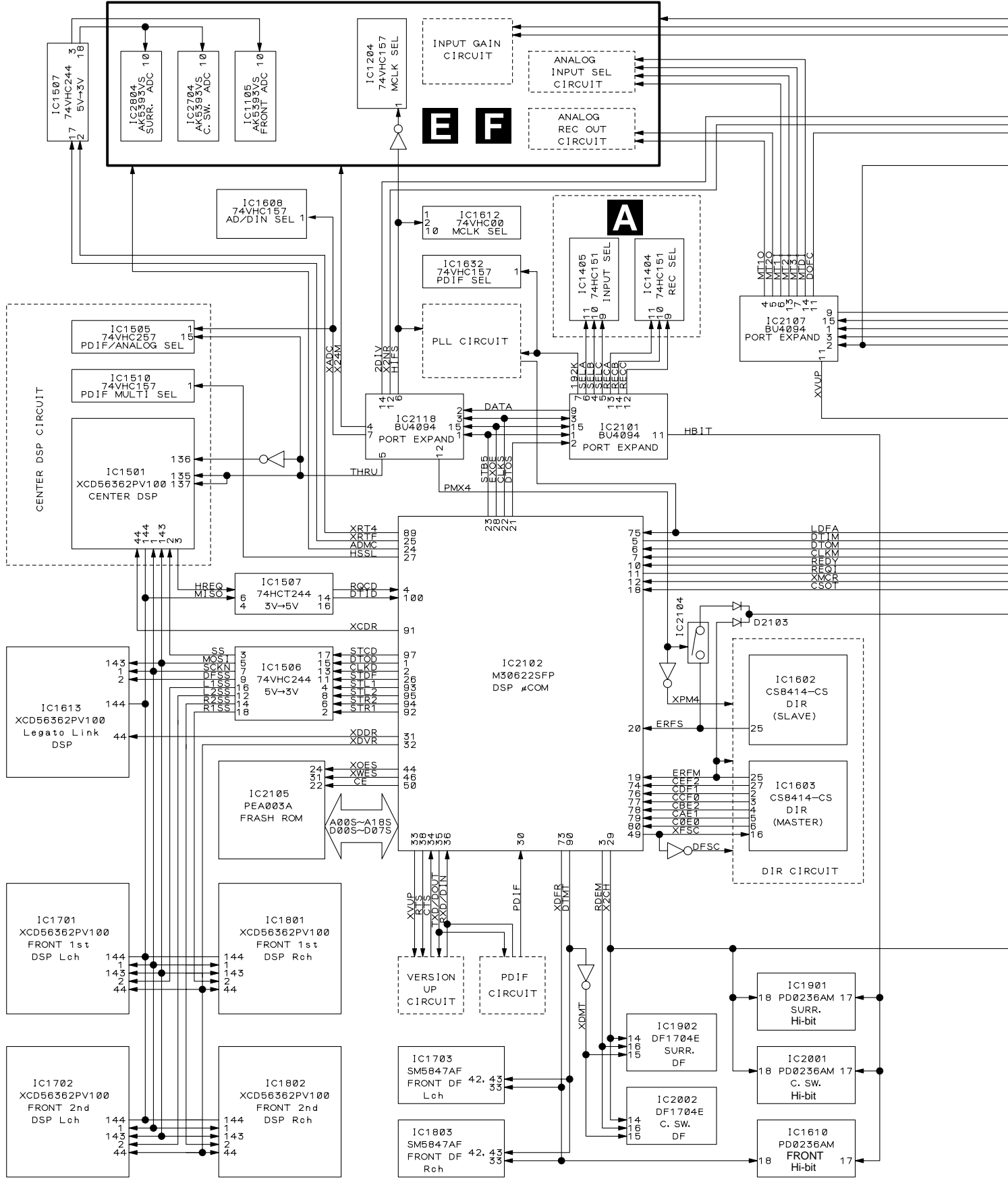

G DSP ASSY

I AUDIO B ASSY

H AUDIO A ASSY

K VOLUME ASSY

L MEMORY ENC.

N MENU ENC.

M INPUT SW

J DISPLAY ASSY

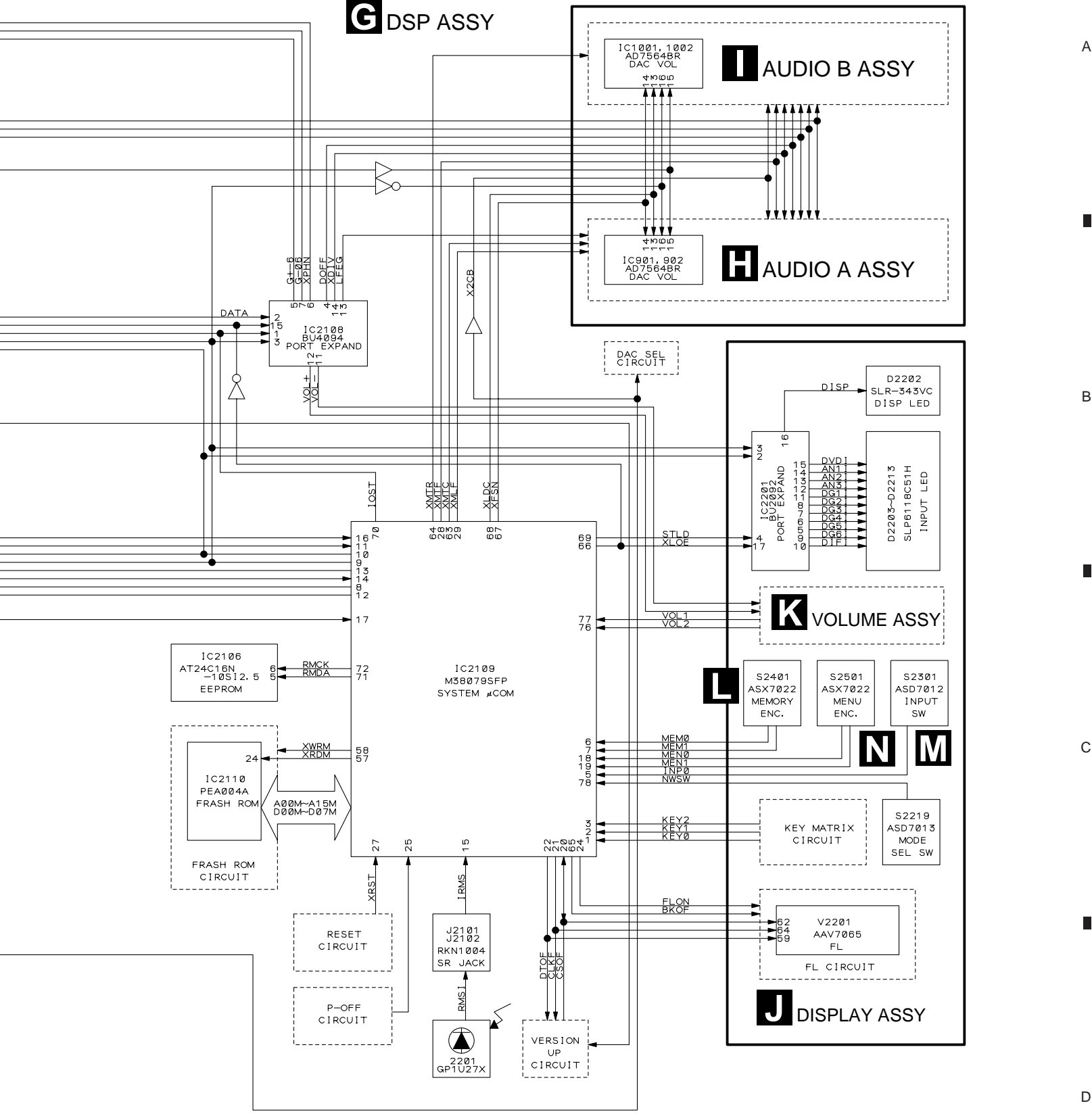

A
B
C
D

3.2 OVERALL WIRING DIAGRAM

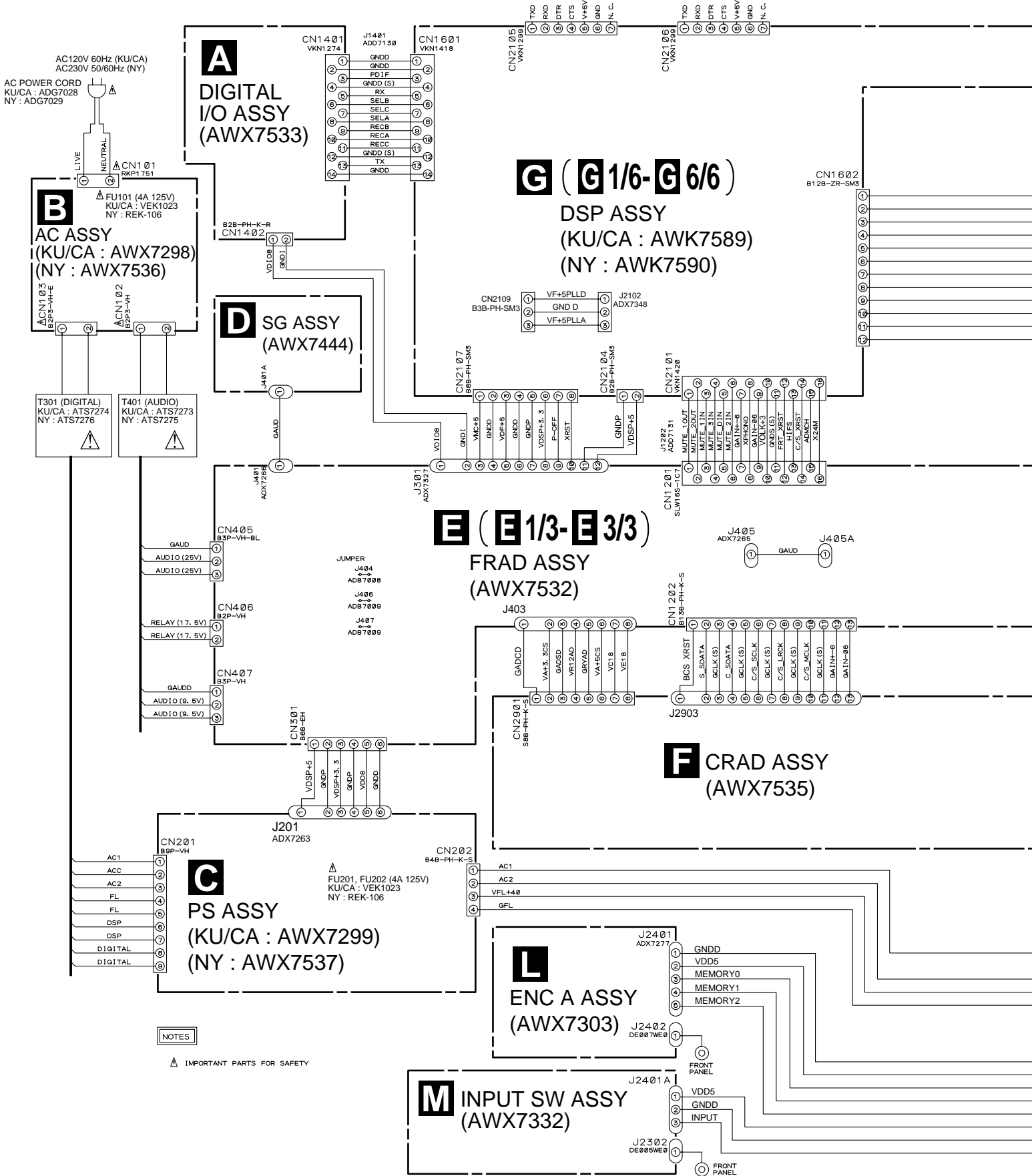

NOTES

⚠ IMPORTANT PARTS FOR SAFETY

Note : When ordering service parts, be sure to refer to "EXPLODED VIEWS AND PARTS LIST" or "PCB PARTS LIST".

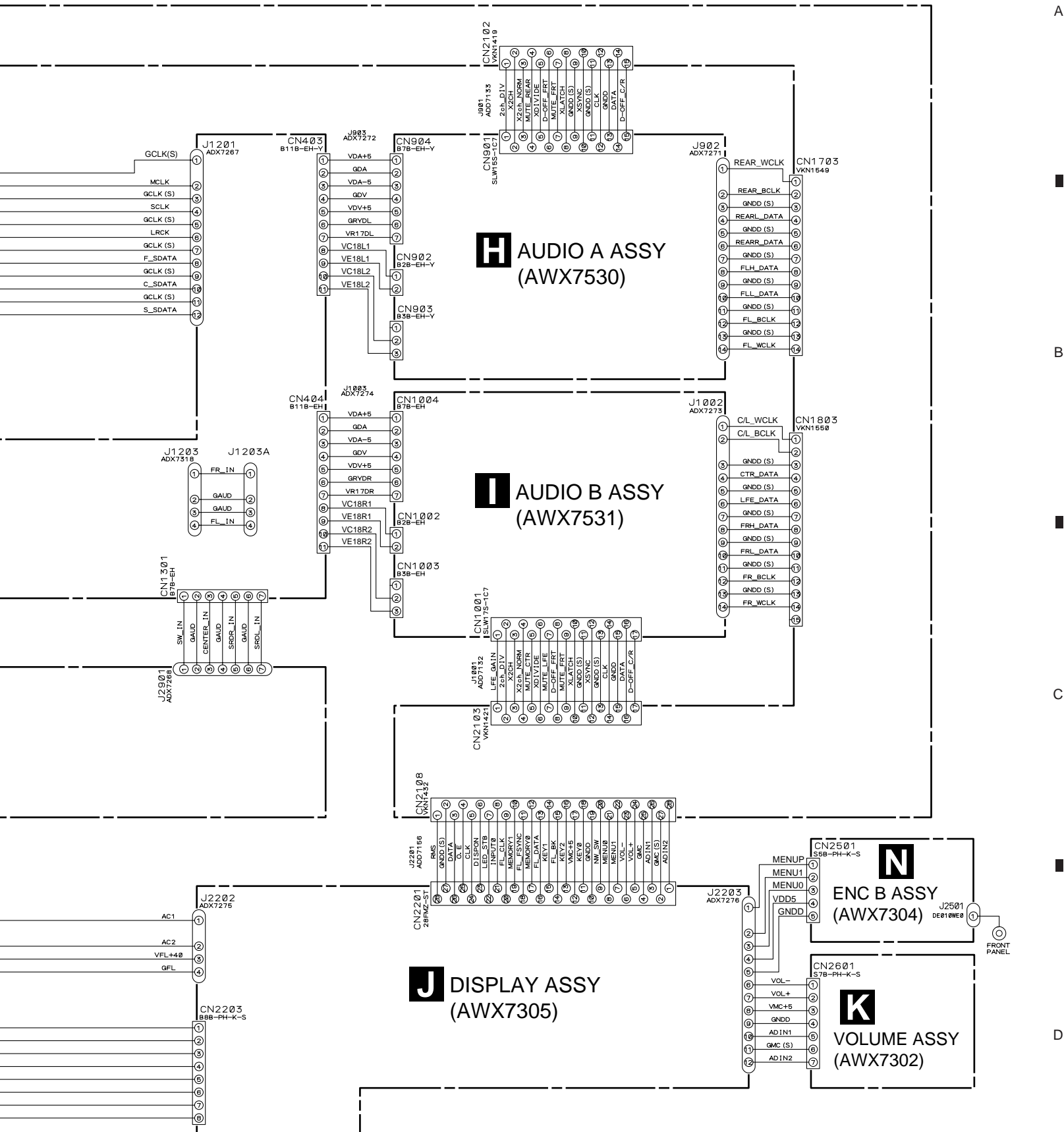

3.3 DIGITAL I/O ASSY

○ : The power supply is shown with the marked box.

A

B

C

D

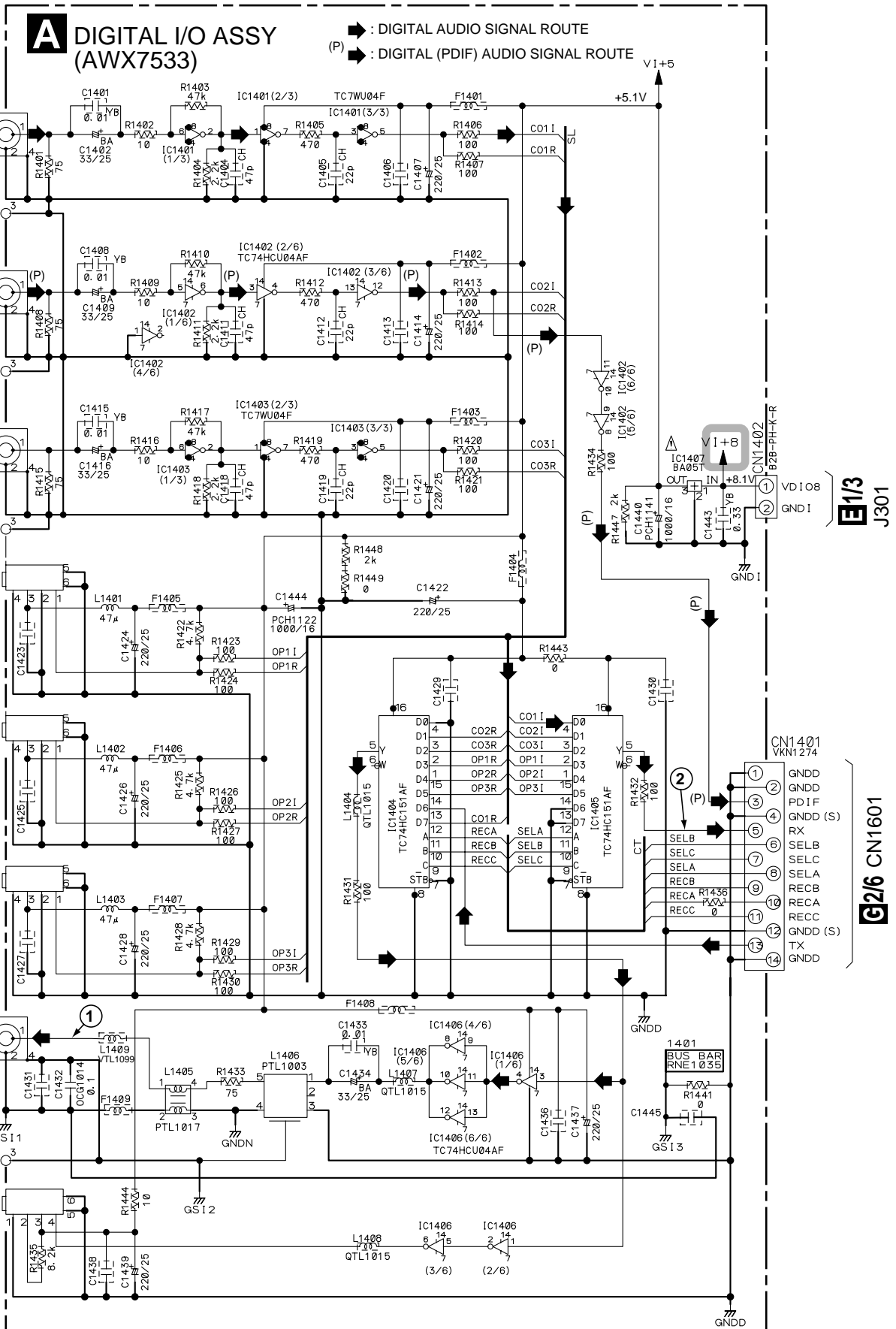

3.4 AC and PS ASSYS

B AC ASSY (KU/CA : AWX7298) (NY : AWX7536)

• NOTE FOR FUSE REPLACEMENT

CAUTION -FOR CONTINUED PROTECTION AGAINST RISK OF FIRE. REPLACE WITH SAME TYPE AND RATINGS ONLY.

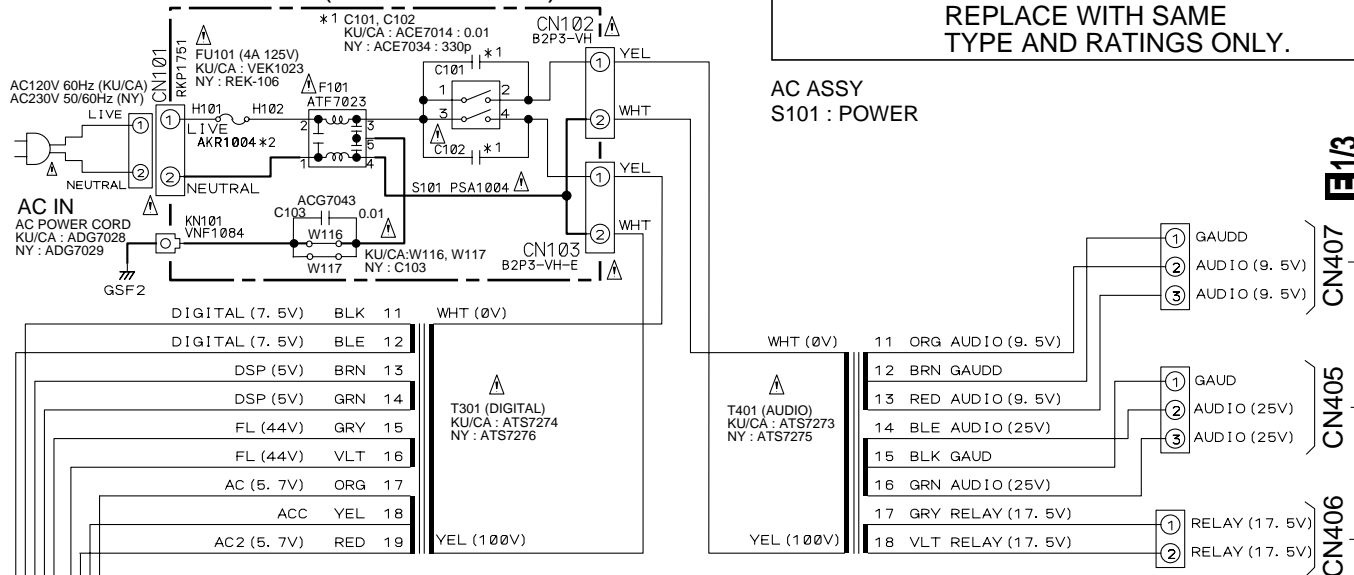

C PS ASSY (KU/CA : AWX7299) (NY : AWX7537)

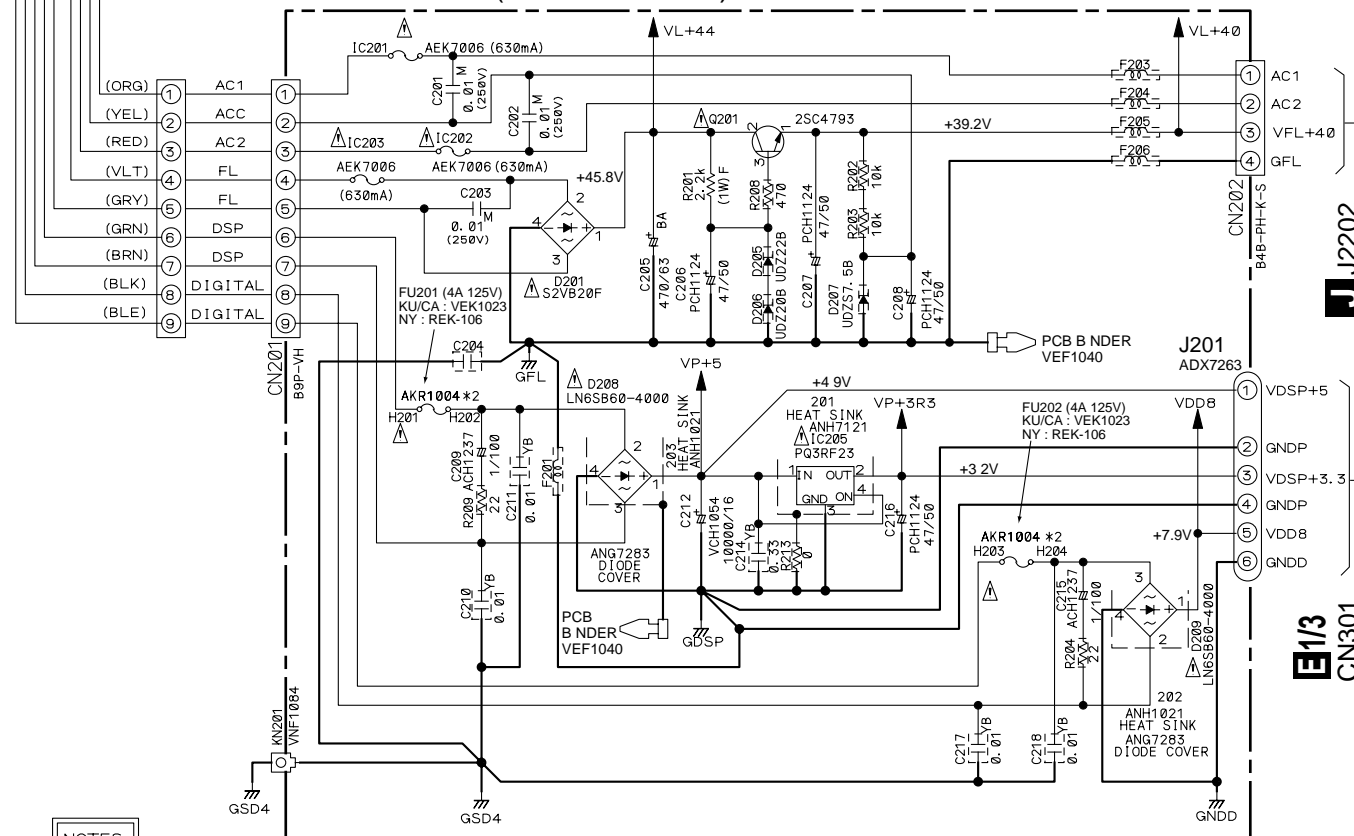

NOTES

▲ IMPORTANT PARTS FOR SAFETY

INDUCTORS Unmarked Unit : μH

FERRITES LFEAD□□□

DTF1070

RESISTORS : Ω

RS1/10S□□□□

RD1/4PU□□□□

CAPACITORS : μF

PCH1128 (220μF/25V)
CKSQYB104K25

CAUTION : FOR CONT NUED PROTECTION AGA NST RISK OF FIRE. REPLACE ONLY WITH SAME TYPE NO. 491.630 MFD, BY LITTELFUSE INC. FOR IC201-IC203 (AEK7006).

3.5 SG and FRAD (1/3) ASSYS

E 1/3 FRAD ASSY (AWX7532)

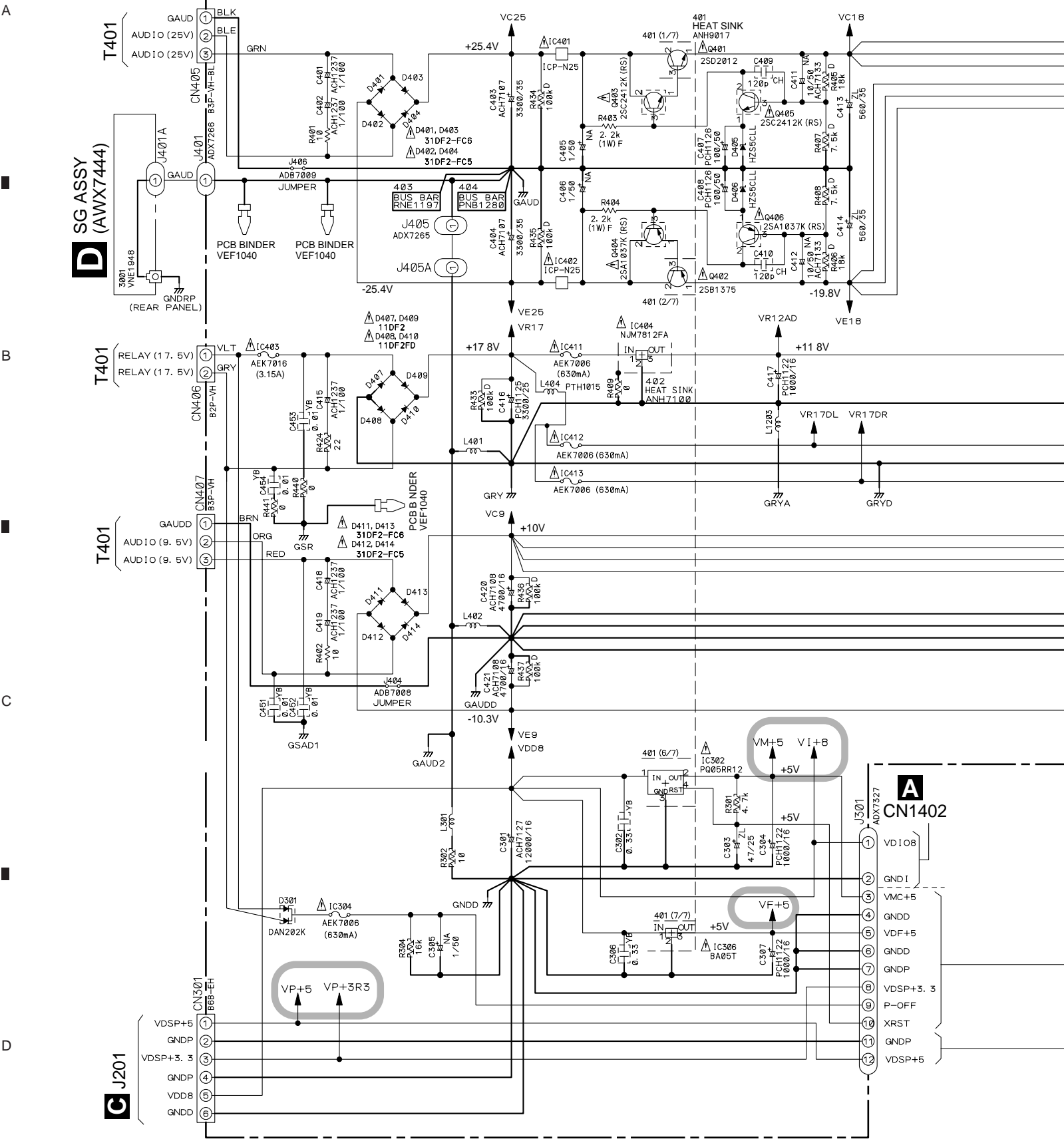



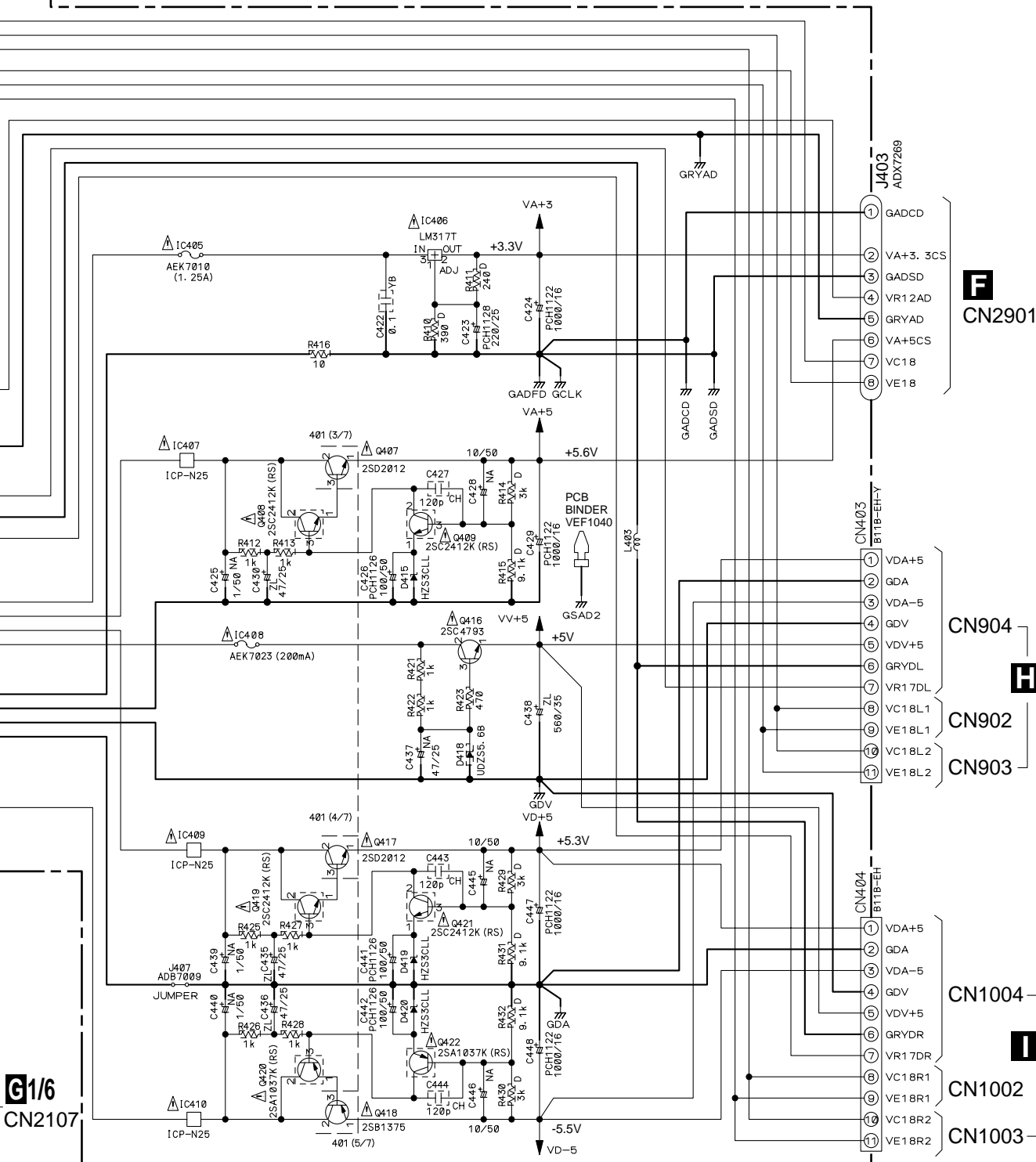

 : The power supply is shown with the marked box.



G/1/6
CN2107

G/1/6
CN2104

NOTES

- ▲ IMPORTANT PARTS FOR SAFETY
- RESISTORS Unmarked Unit : Ω
-  RS1/10S□□□□□
-  RS1/10SE□□□□□
-  RDR1/4PM□□□□□
- FERRITES
-  RTF1167

CAUTION : FOR CONT NUED PROTECTION AGA NST RISK OF F RE. REPLACE ONLY WITH SAME TYPE NO. 491.630 MFD, BY LITTELFUSE INC. FOR IC304, IC411-IC413 (AEK7006).

CAUTION : FOR CONT NUED PROTECTION AGA NST RISK OF F RE. REPLACE ONLY WITH SAME TYPE NO. 491.125 MFD, BY LITTELFUSE INC. FOR IC405 (AEK7010).

CAUTION : FOR CONT NUED PROTECTION AGA NST RISK OF F RE. REPLACE ONLY WITH SAME TYPE NO. 4913.15 MFD, BY LITTELFUSE INC. FOR IC403 (AEK7016).

CAUTION : FOR CONTINUED PROTECTION AGAINST RISK OF F RE REPLACE ONLY WITH SAME TYPE NO. 491.200 MFD, BY LITTELFUSE INC FOR IC408 (AEK7023).

F
CN2901

H
CN904

CN902

CN903

CN1004

CN1002

CN1003

3.6 FRAD ASSY (2/3)

E 2/3 FRAD ASSY (AWX7532)

E 3/3

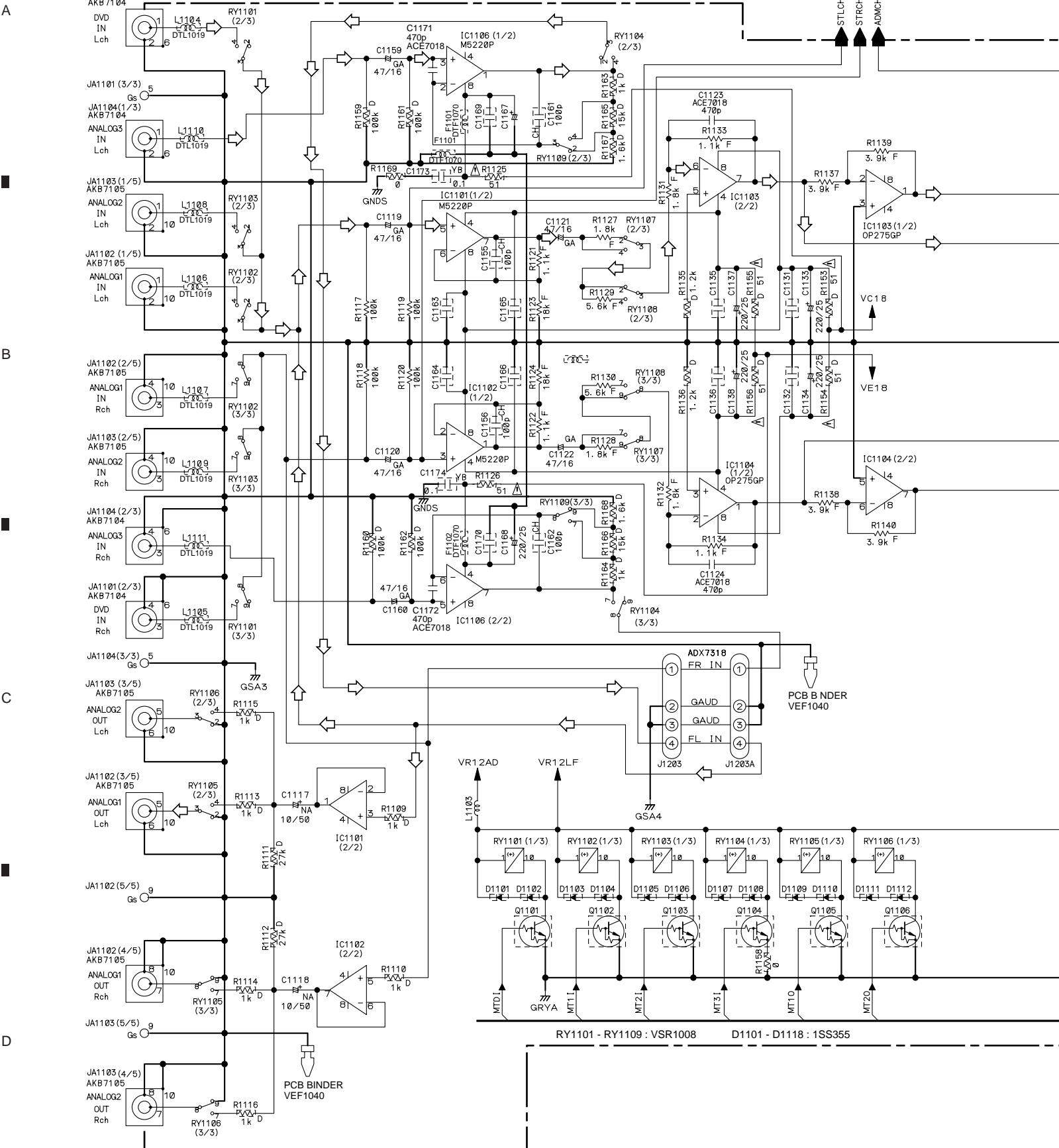

↷ : ANALOG AUDIO SIGNAL ROUTE (FRONT)
 (M) ↷ : ANALOG AUDIO SIGNAL ROUTE (Multi)

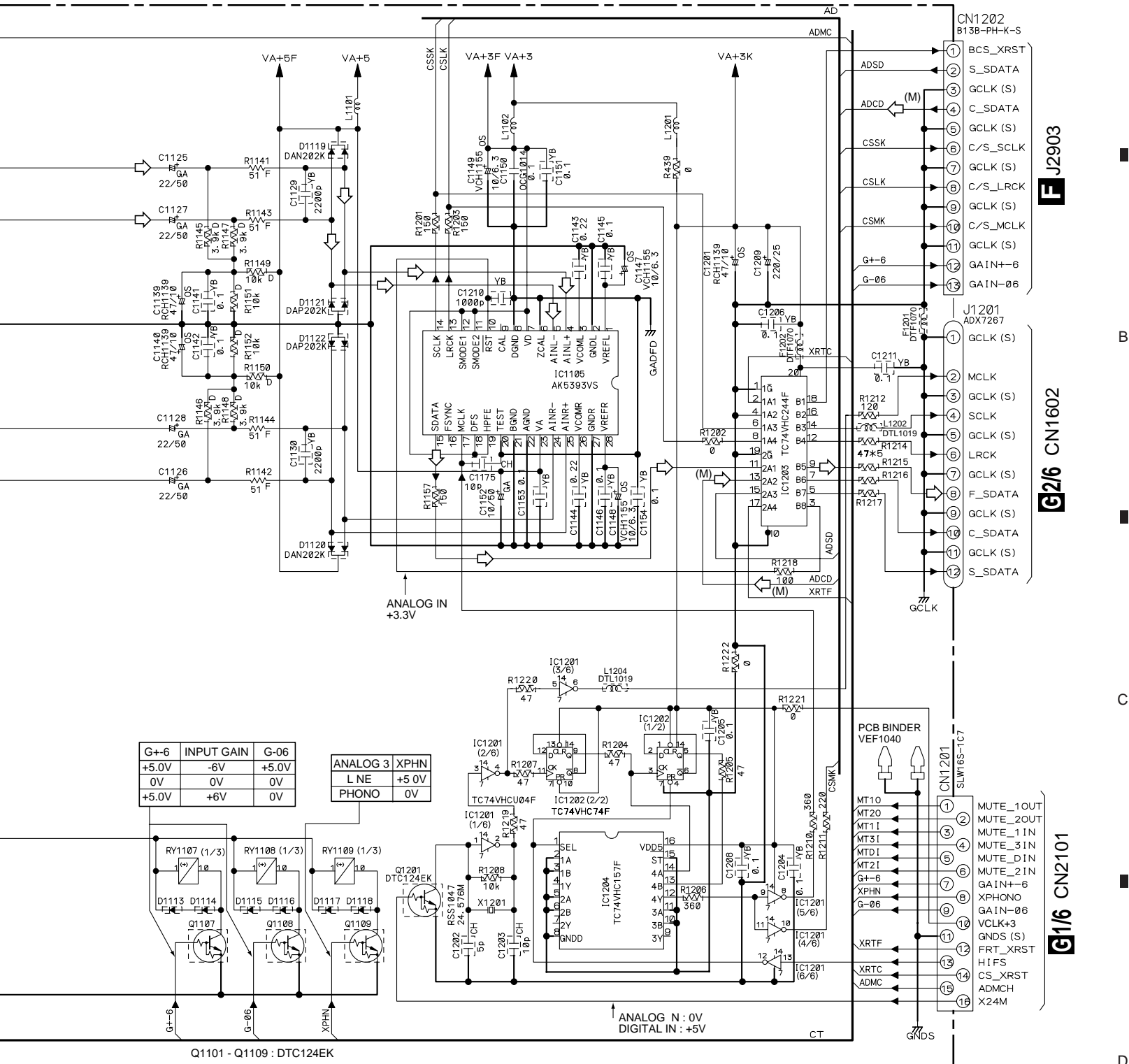

NOTES

CAPACITORS Unmarked Unit : μF
 PCH1128 (220μF/25V)
 CKSQYB473K50 (0.047μF/50V)

RESISTORS : Ω
 F RDR1/4PM□□□□
 RDR1/4PM□□□□
 RS1/10S□□□□
 RN1/10SE□□□□

FERRITES
 RTF1167

F J2903

G2/6 CN1602

G1/6 CN2101

A

B

C

D

3.7 FRAD (3/3) and CRAD ASSYS

NOTES

CAPACITORS Unmarked Unit : μF

PC1128 (220 μF /25V)

CKSQYB473K50 (0.047 μF /50V)

RESISTORS : Ω

RS1/10S

RN1/10SE

RN1/10SC51R0D

RDR1/4PM

FERRITES

RTF1167

3/3 FRAD ASSY (AWX7532)

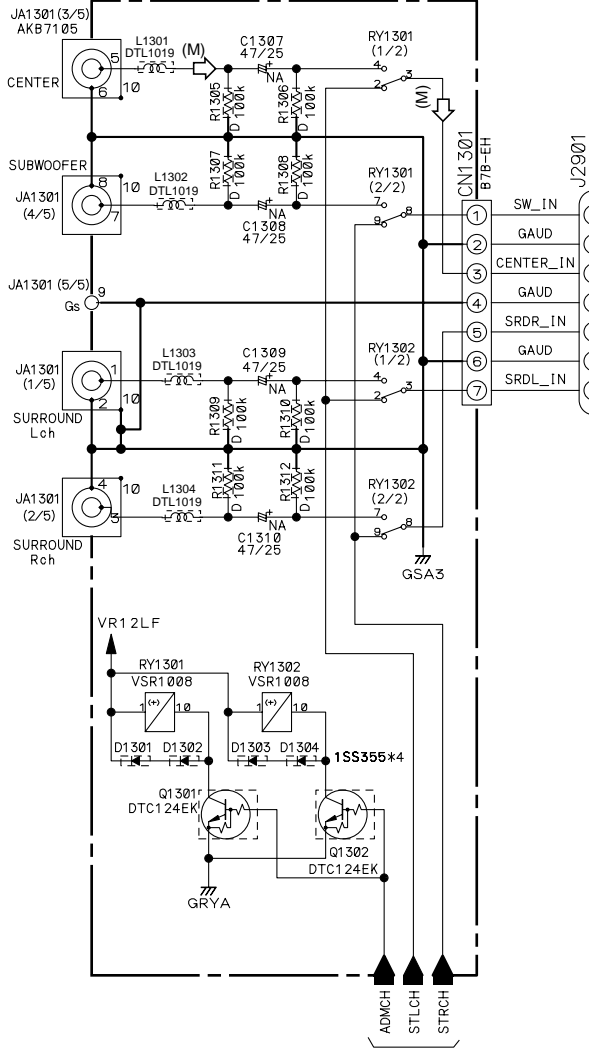

CRAD ASSY (AWX7535)

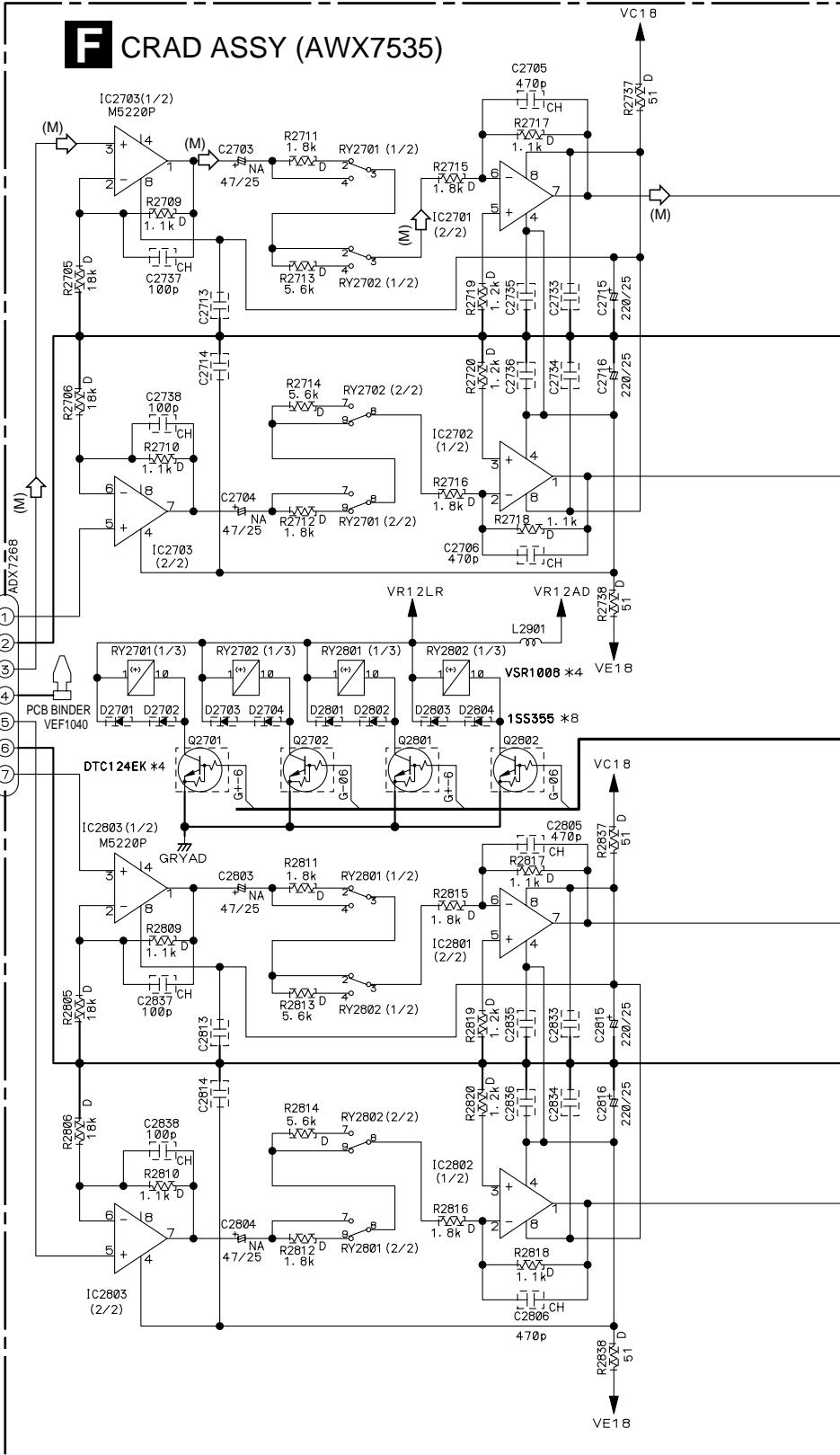

 : The power supply is shown with the marked box.

(M)  : ANALOG AUDIO SIGNAL ROUTE (Multi)

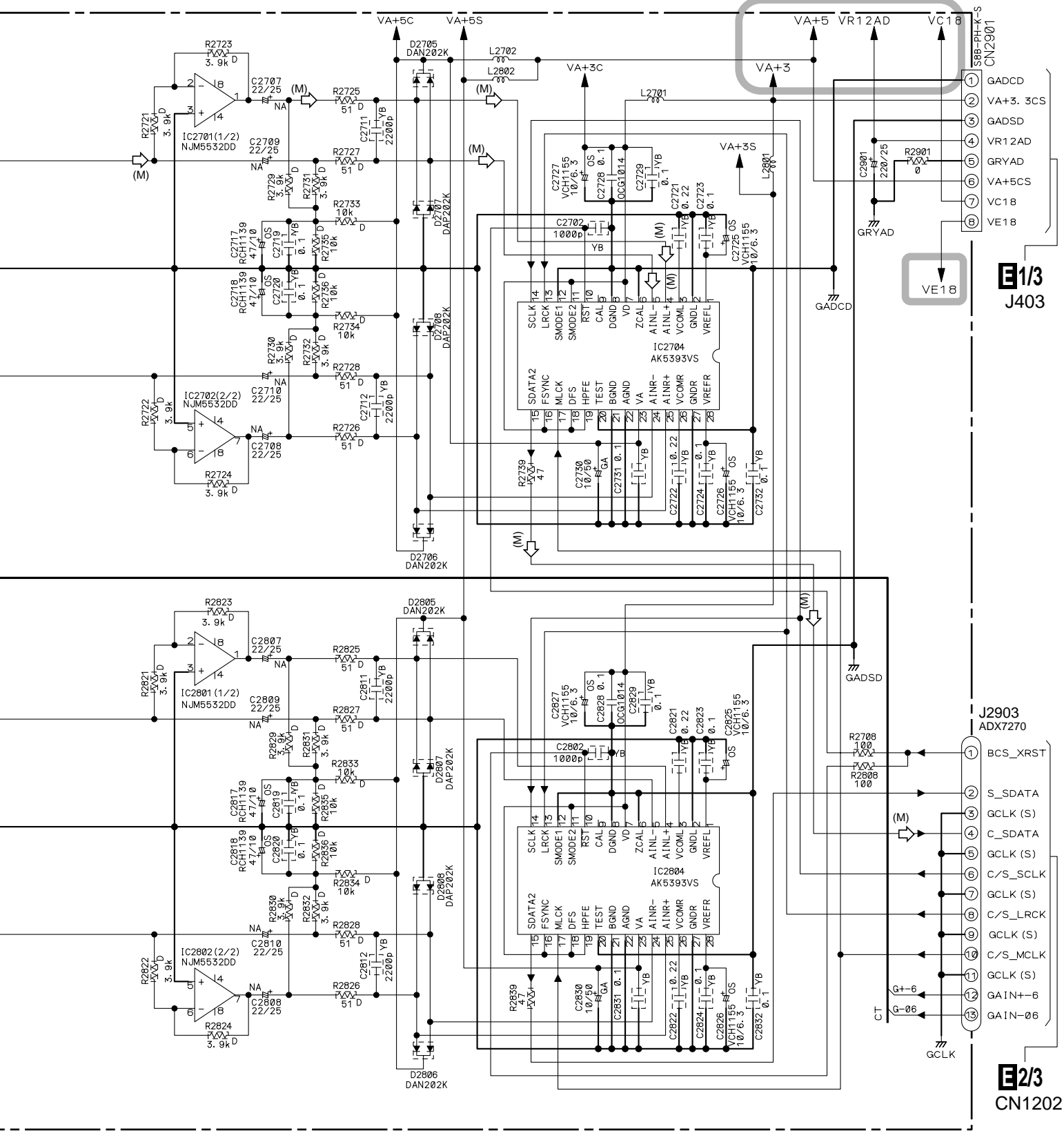

E1/3
J403

J2903
ADX7270

E2/3
CN1202



3.8 DSP ASSY (1/6)

A

B

C

D

G2/6

G6/6

G4/6, 5/6

G3/6

E2/3 CN1201

H CN901

I CN1001

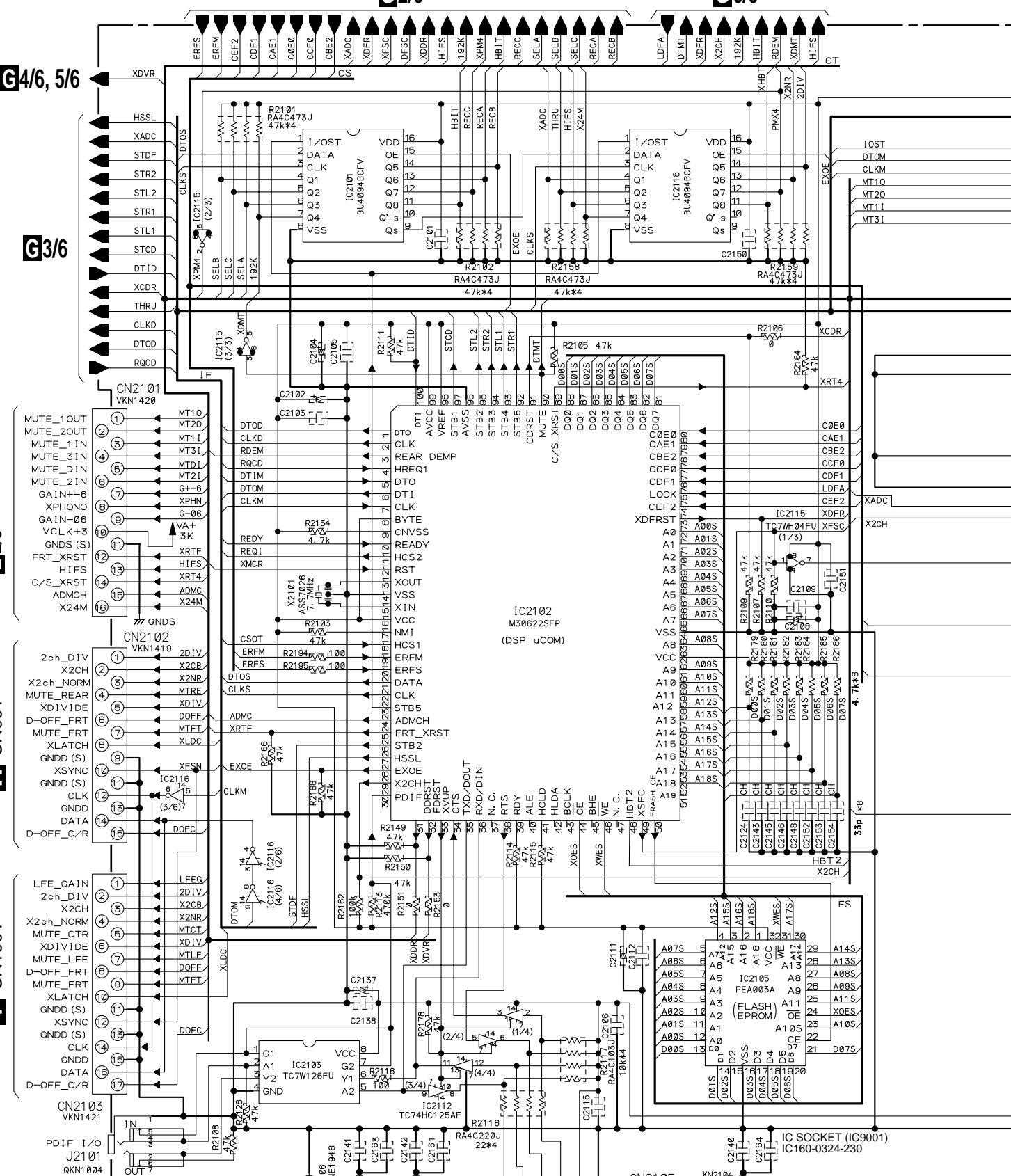

NOTES

RESISTORS
 Unmarked Unit: Ω
 RS1/16SC000

CAPACITORS : μF
 CEV470M6R3
 CKSRYF104Z25

GND RP REAR PANEL
 GND S1
 GND S2

TXD
 RXD
 DTR
 CTS
 GND
 N. C.

V+5V
 GND
 N. C.

GND S3

3.9 DSP ASSY (2/6)

A

B

C

D

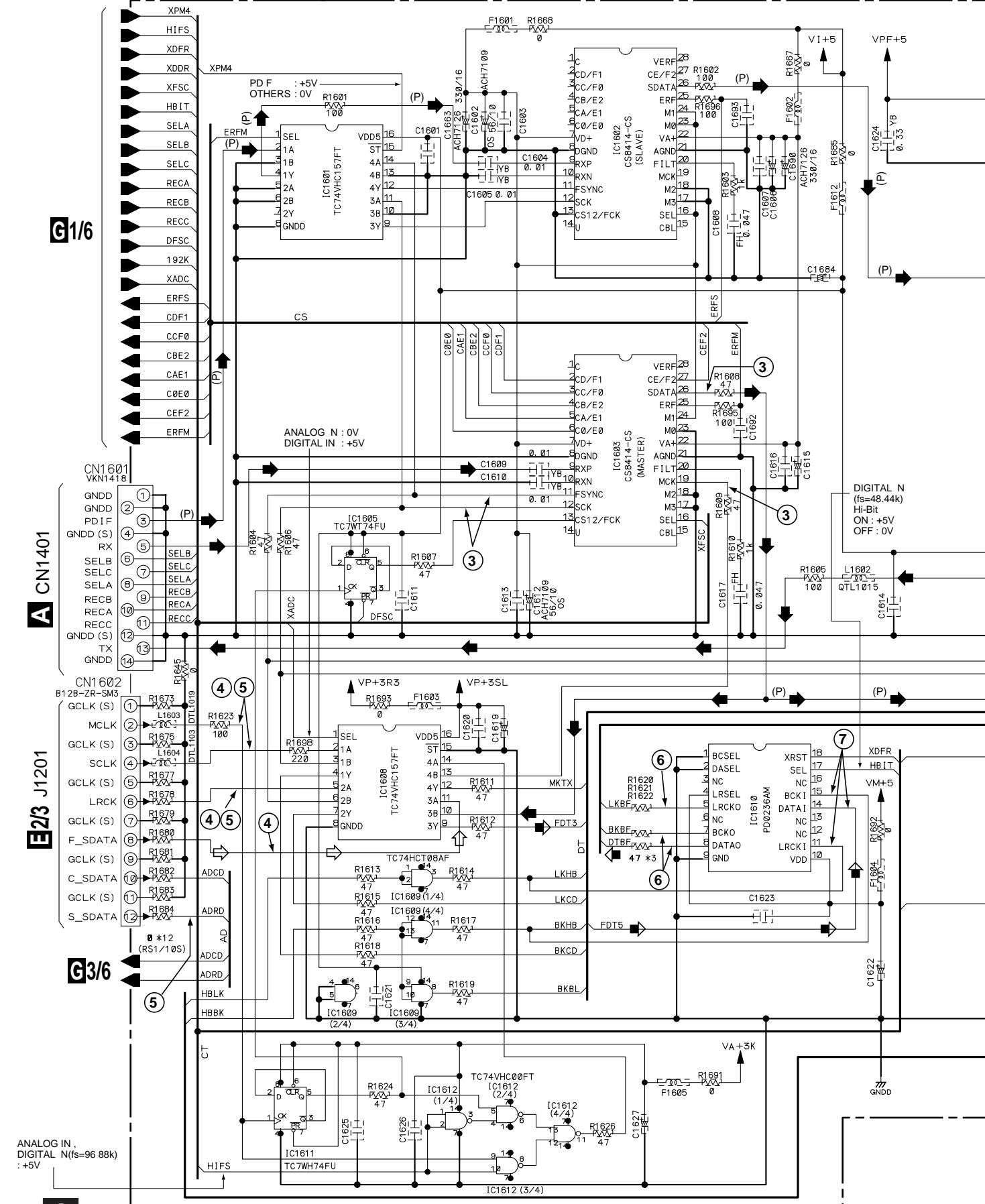

G1/6

A CN1401

E2/3 J1201

G3/6

G2/6

G 2/6 DSP ASSY (KU/CA : AWK7589) (NY : AWK7590)

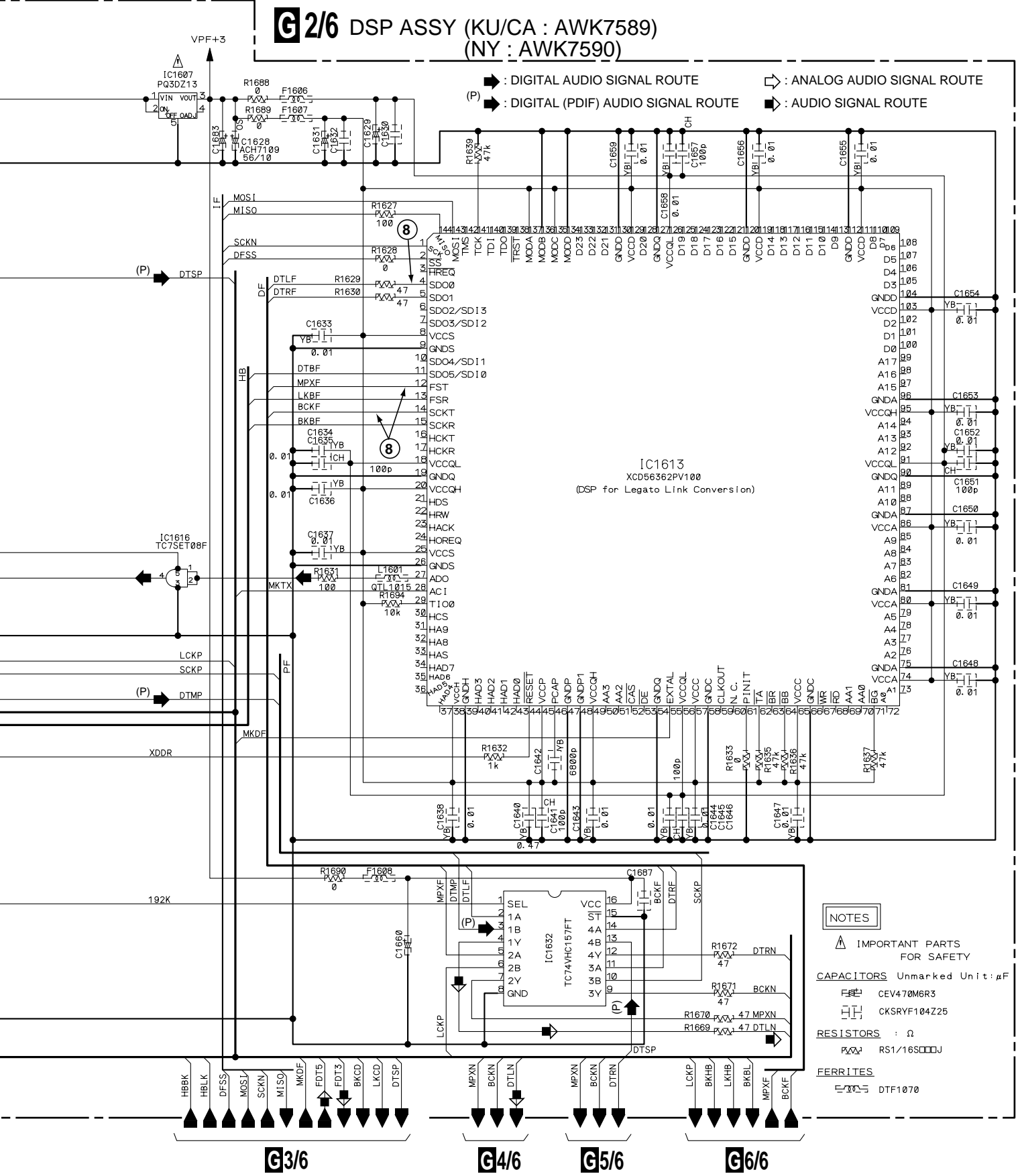

NOTES

▲ IMPORTANT PARTS FOR SAFETY

CAPACITORS Unmarked Unit: μF

CEV470M6R3
 CKSRYF104Z25

RESISTORS : Ω

RS1/16S□□□□

FERRITES

DTF1070

G3/6 **G4/6** **G5/6** **G6/6**

3.10 DSP ASSY (3/6)

A

B

C

D

G 3/6 DSP ASSY (KU/CA : AWK7589)
(NY : AWK7590)

G1/6

G4/6

G5/6

G6/6

G2/6

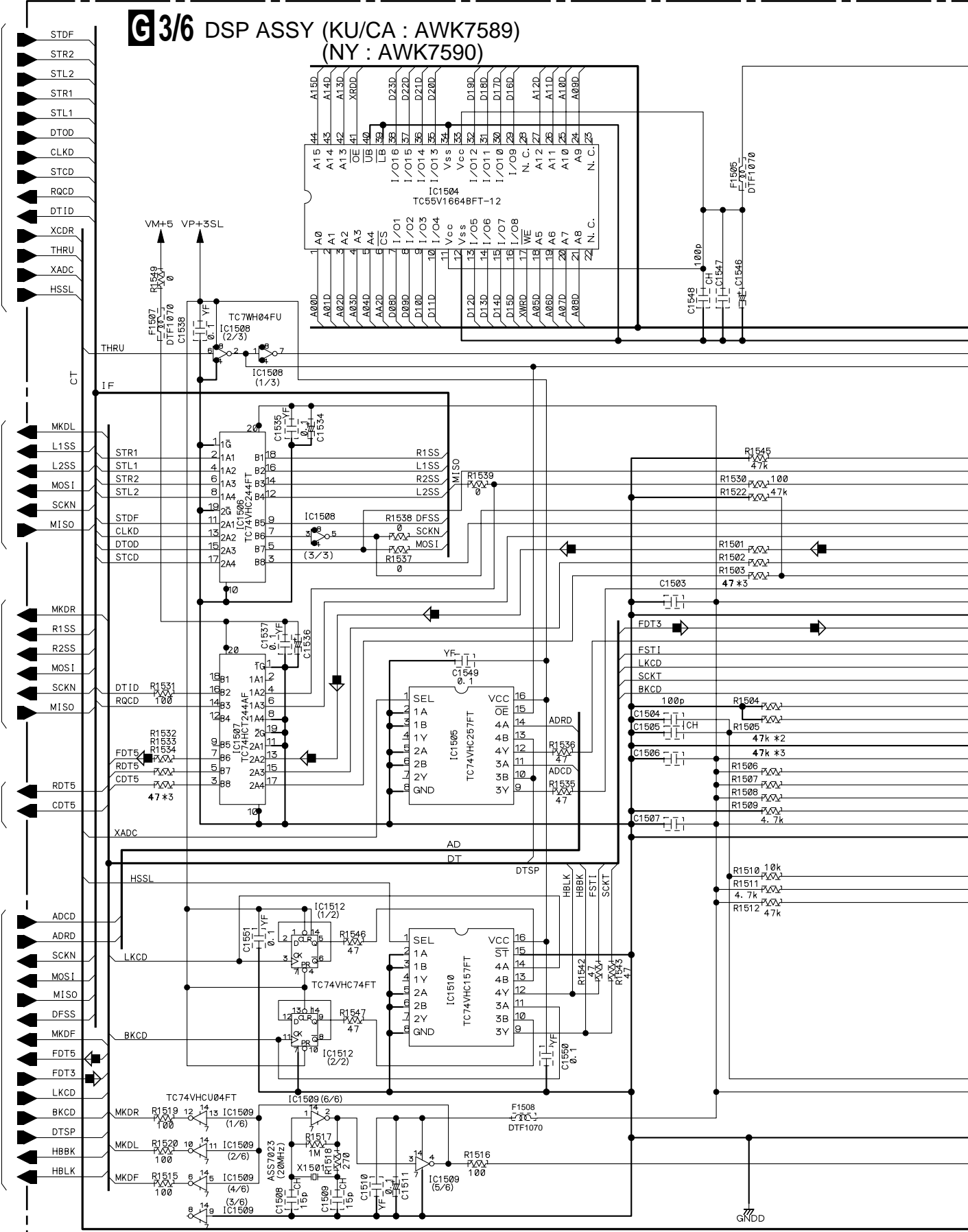

G 3/6

▶ : AUDIO SIGNAL ROUTE

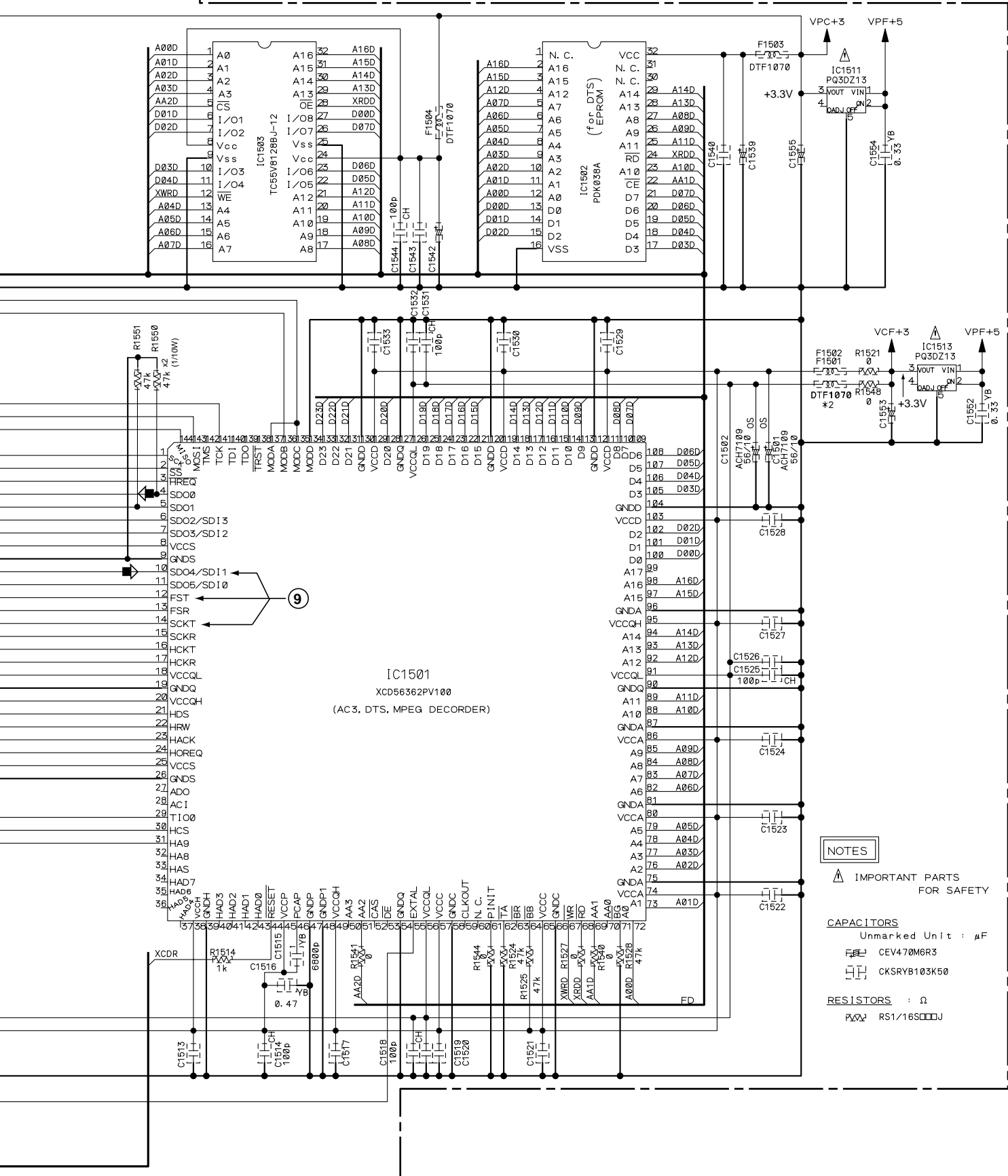

NOTES

▲ IMPORTANT PARTS FOR SAFETY

CAPACITORS
Unmarked Unit : μ F

CEV470M6R3
CKSRVB103K50

RESISTORS : Ω
RS1/16S000J

A

B

C

D

3.11 DSP ASSY (4/6)

G 4/6 DSP ASSY (KU/CA : AWK7589)
(NY : AWK7590)

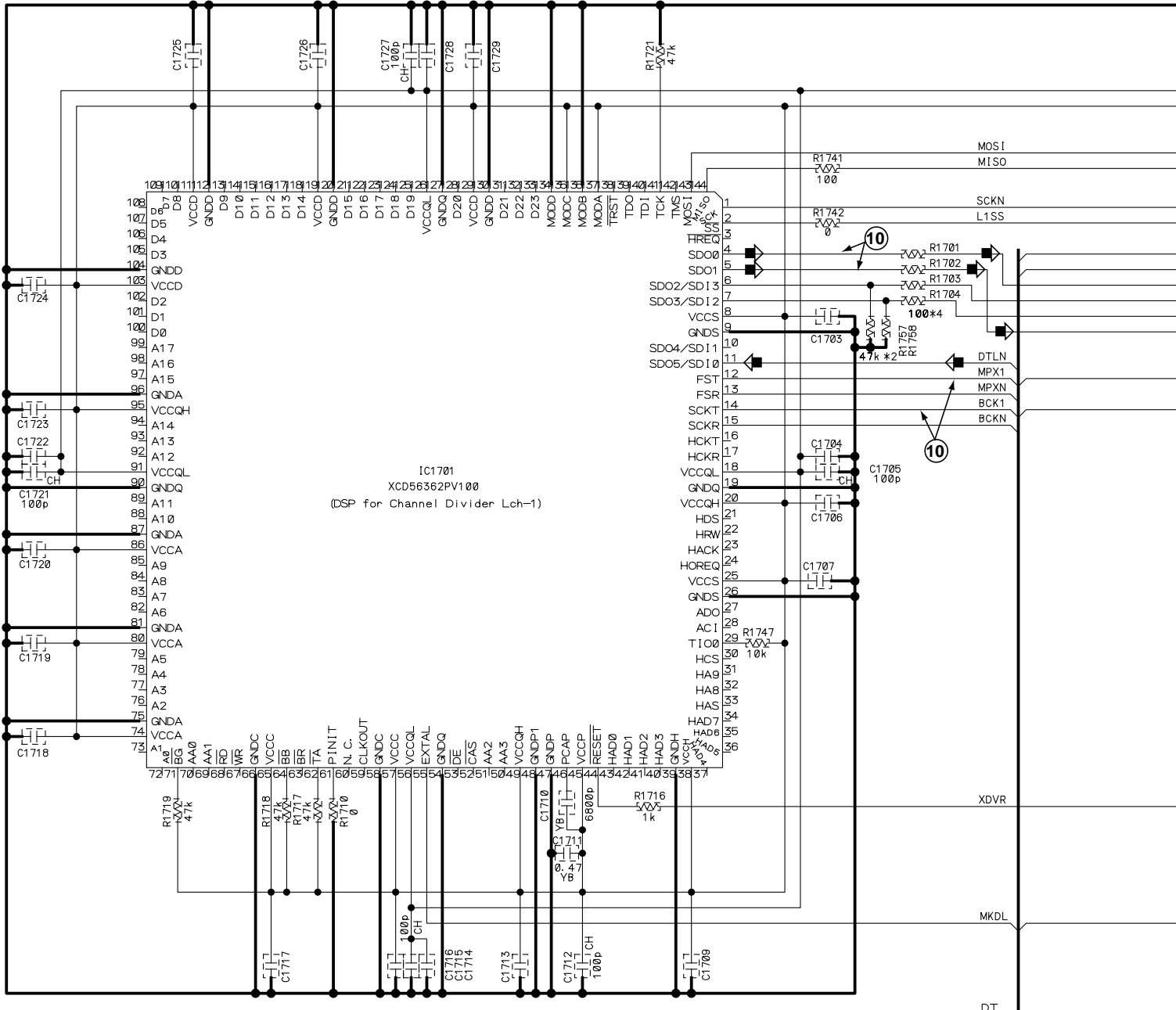

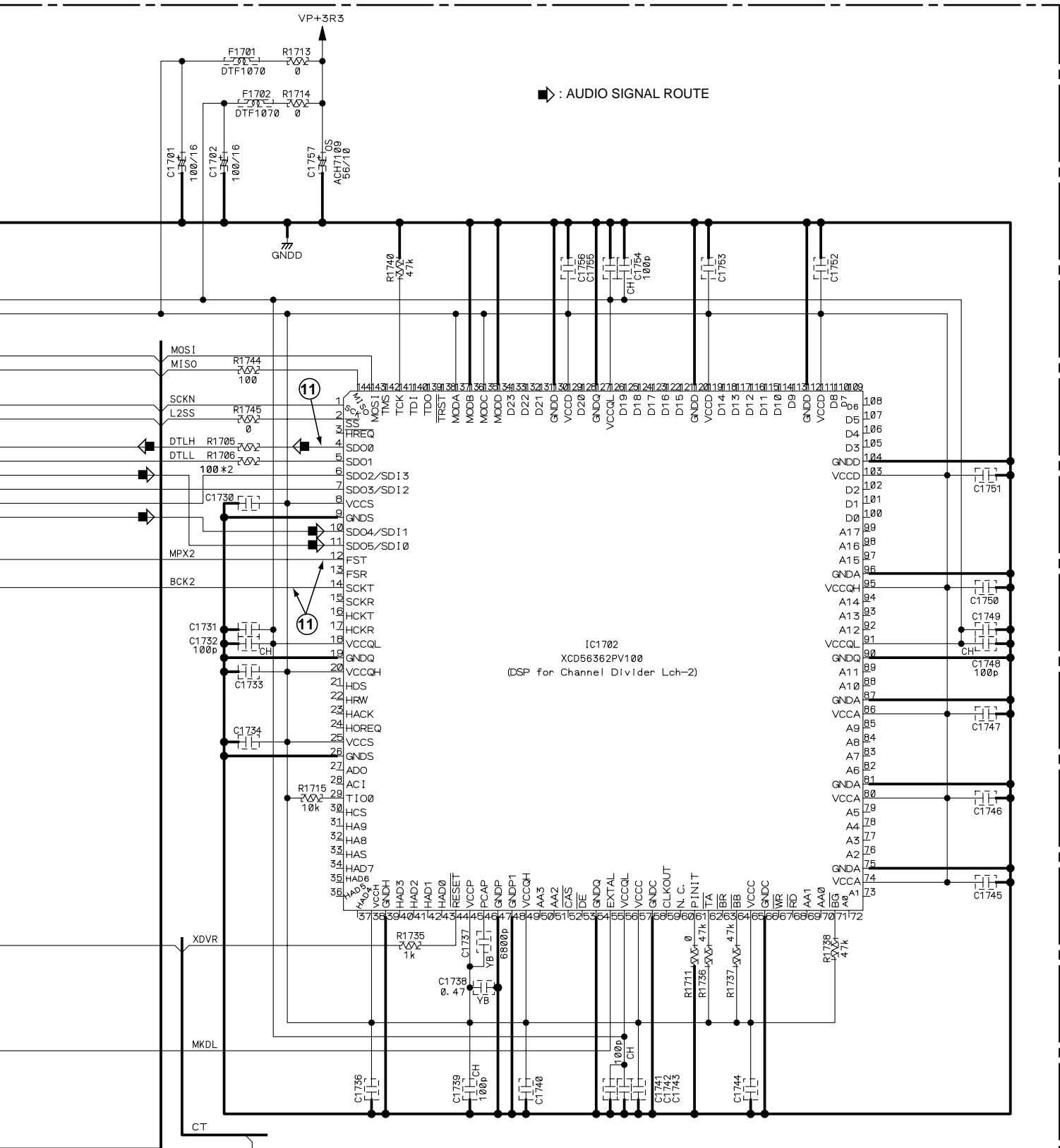

NOTES

RESISTORS Unmarked Unit : Ω
 RS1/16S000J

CAPACITORS : μF
 CEV470M6R3
 CKSRYB103K50



3.12 DSP ASSY (5/6)

G5/6 DSP ASSY (KU/CA : AWK7589)
(NY : AWK7590)

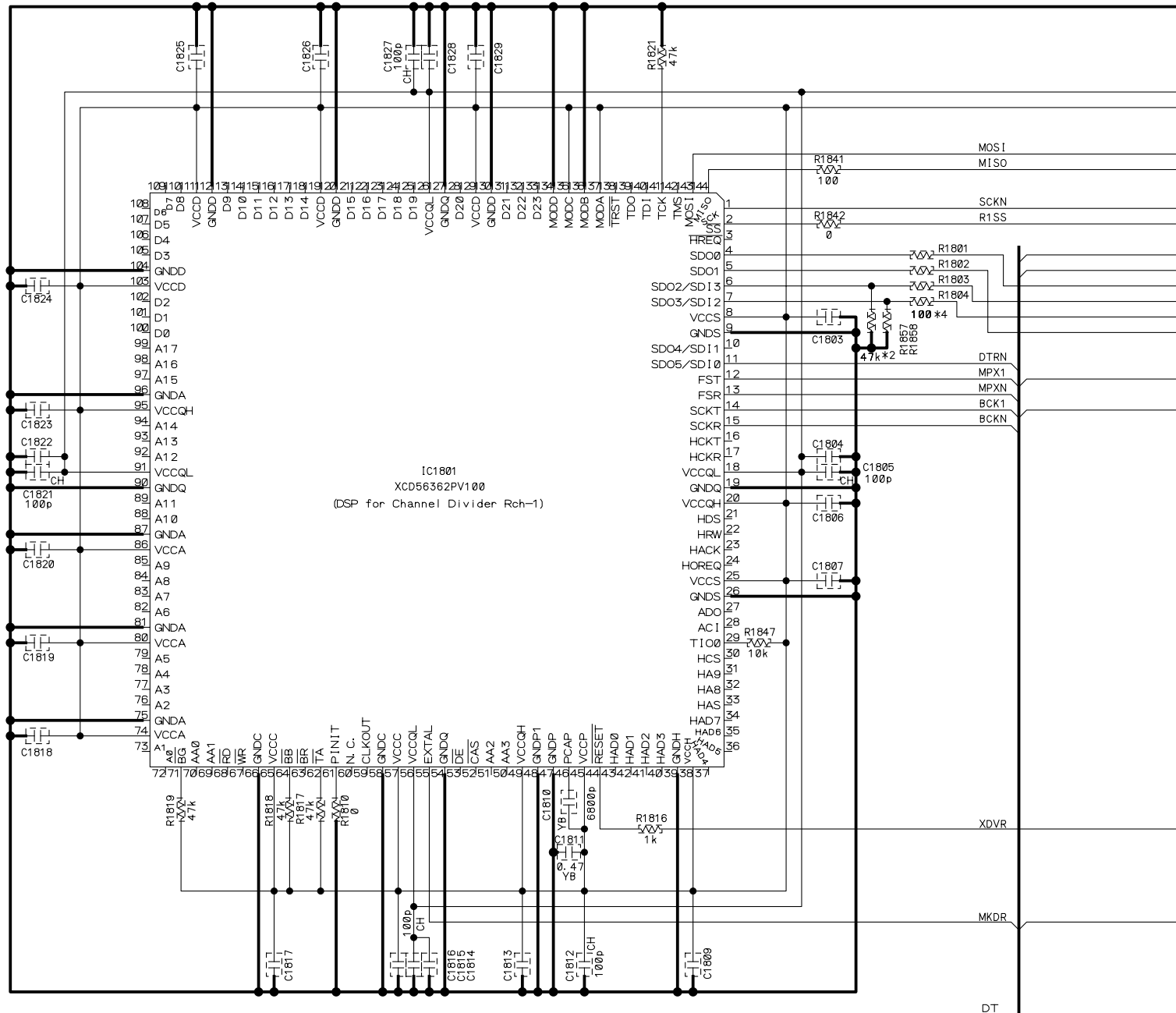

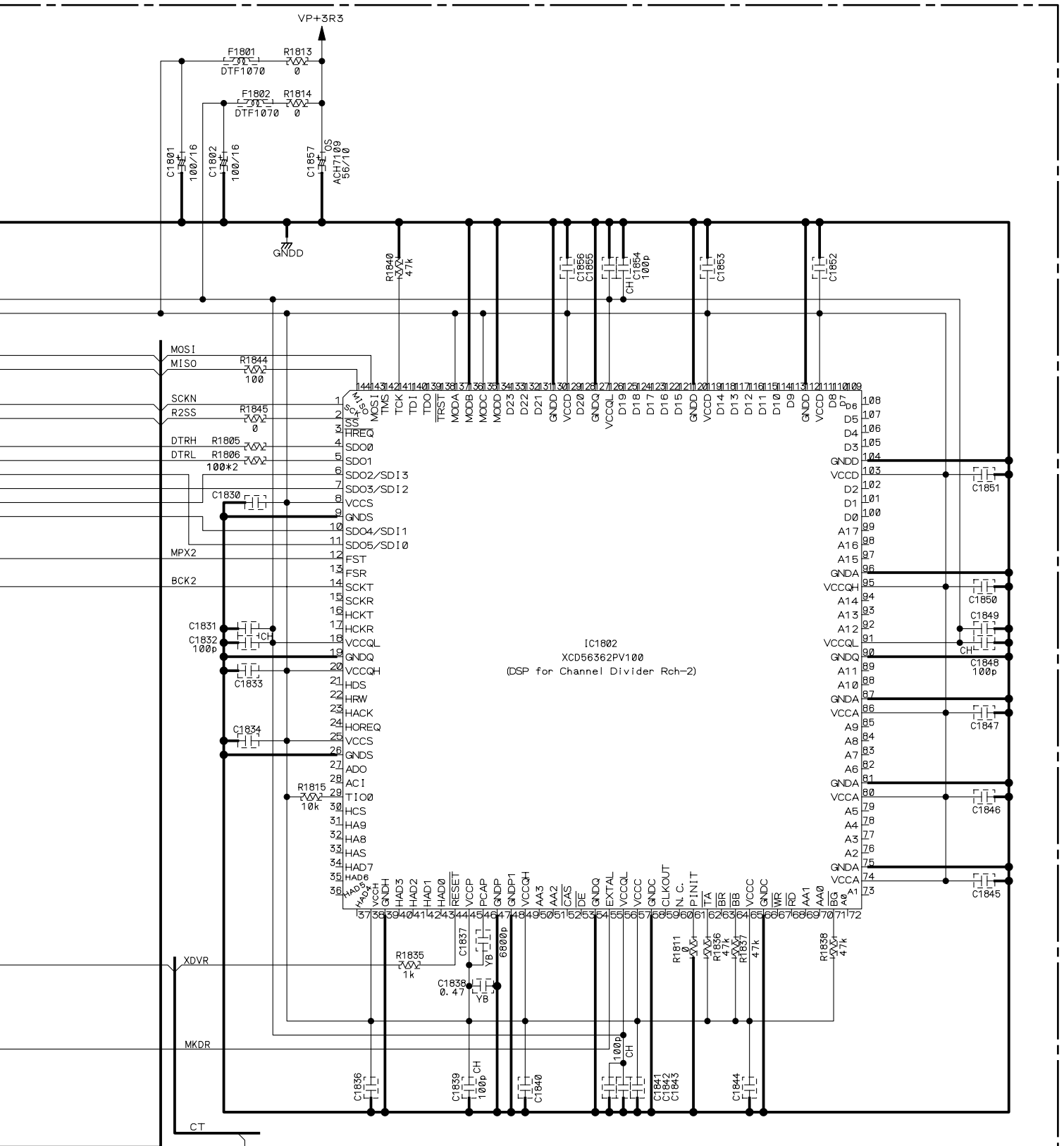

NOTES

RESISTORS Unmarked Unit : Ω
 RS1/16S□□□□

CAPACITORS : μF
 CEV470M6R3
 CKSRYB103K50



3.13 DSP ASSY (6/6)

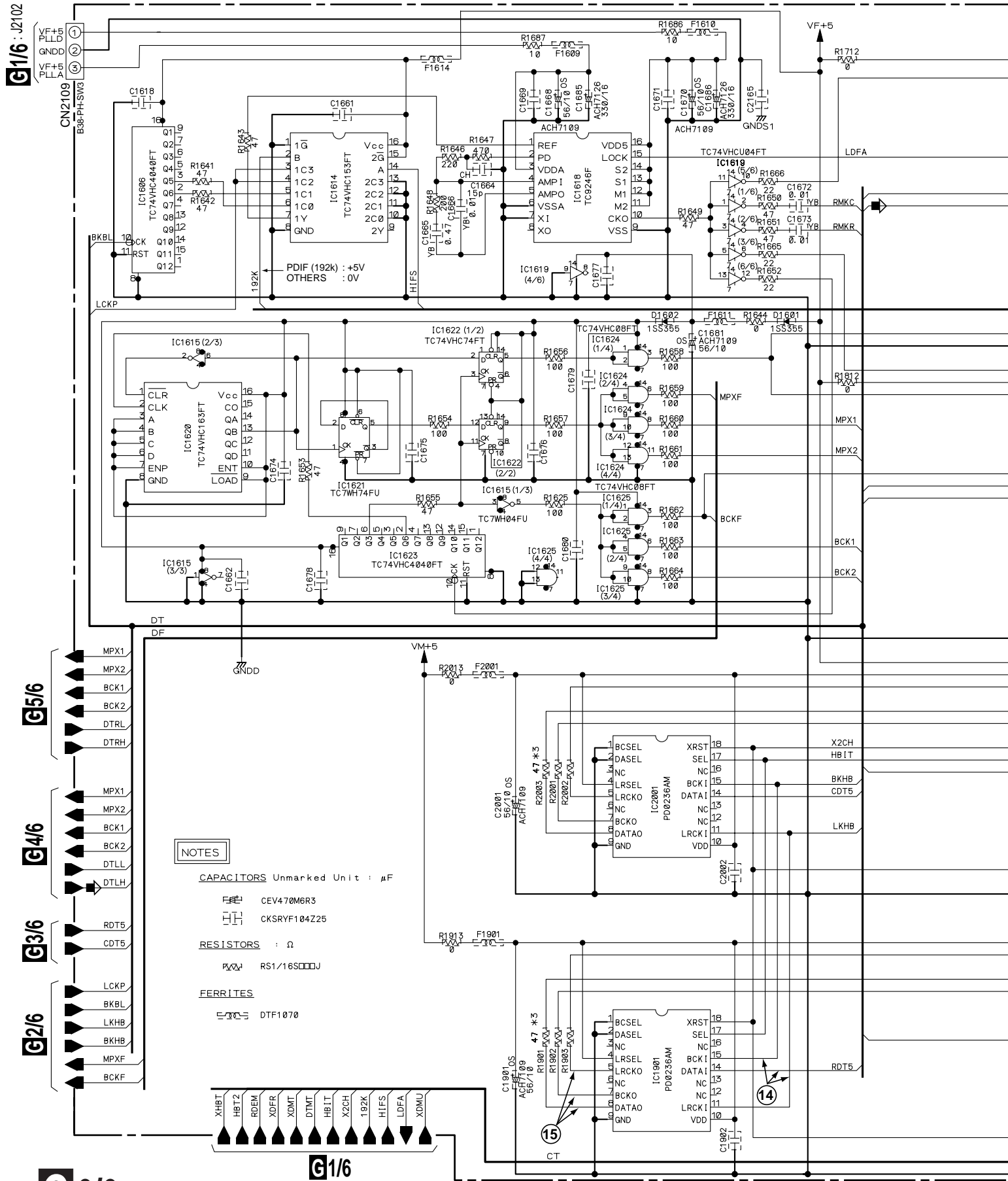

NOTES

- CAPACITORS Unmarked Unit : μ F
- CEV470M6R3
- CKSRVF104Z25
- RESISTORS : Ω
- RS1/16S000J
- FERRITES
- DTF1070

G6/6 DSP ASSY (KU/CA : AWK7589) (NY : AWK7590)

▶ : AUDIO SIGNAL ROUTE

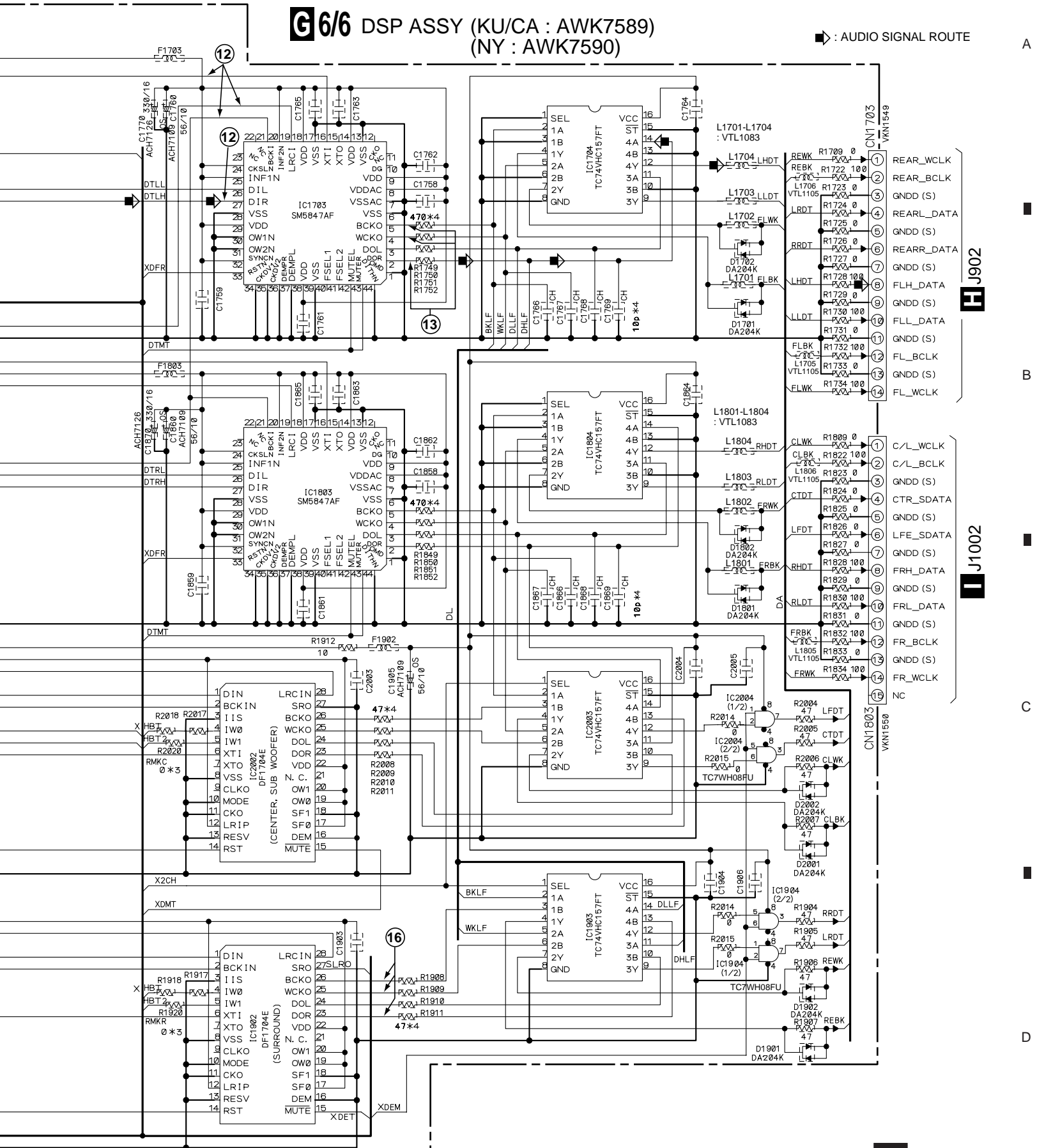

3.14 AUDIO A ASSY

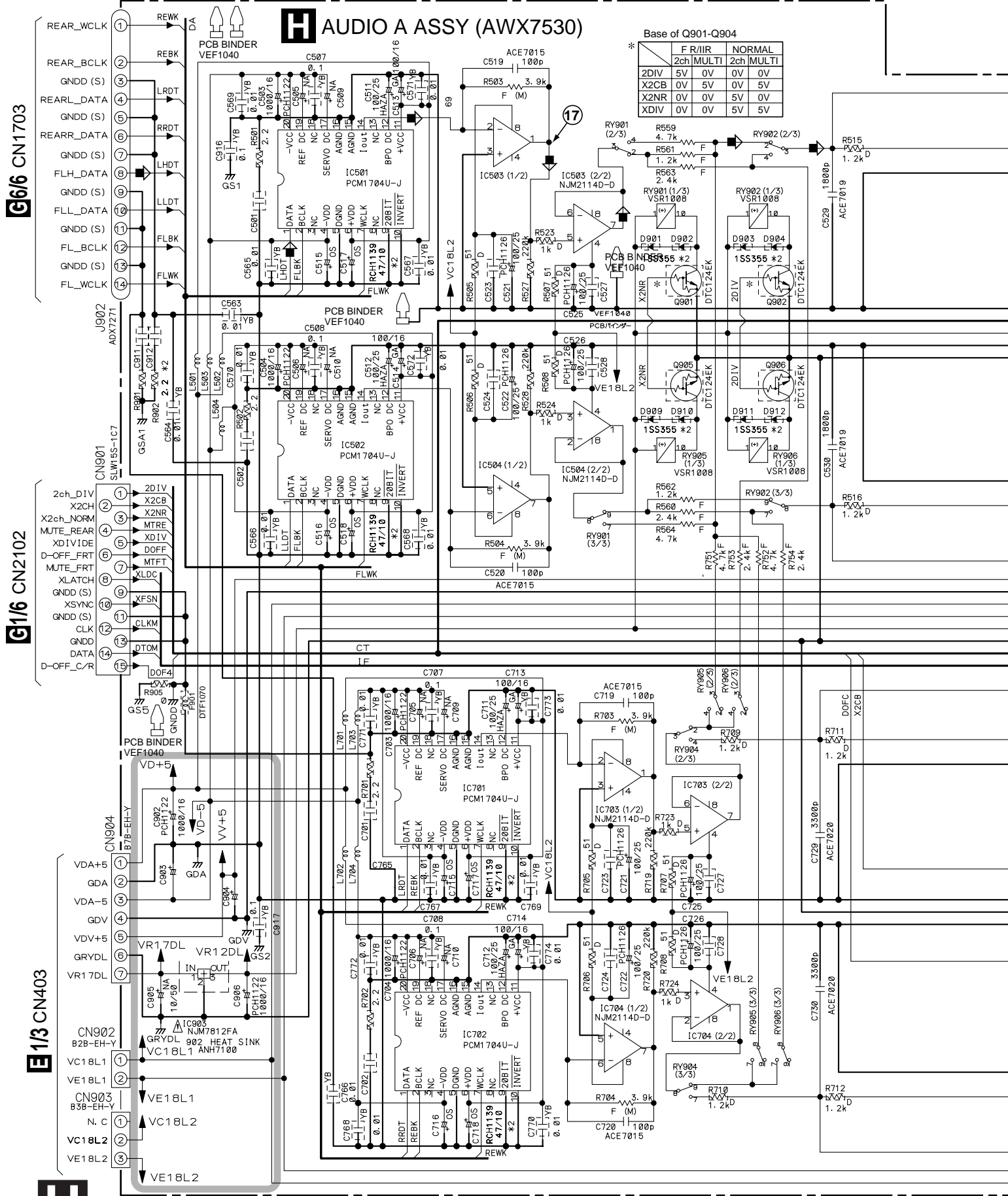

NOTES

IMPORTANT PARTS FOR SAFETY FERRITES

CAPACITORS

Unmarked Unit : μF CENA101M25 (100μF/25V) PCH1128 (220μF/25V) CKSQYB473K50 (0.047μF)

RESISTORS : Ω

RS1/10S RN1/10SE RDR1/4PM RDM1/2PF

▶ : AUDIO SIGNAL ROUTE

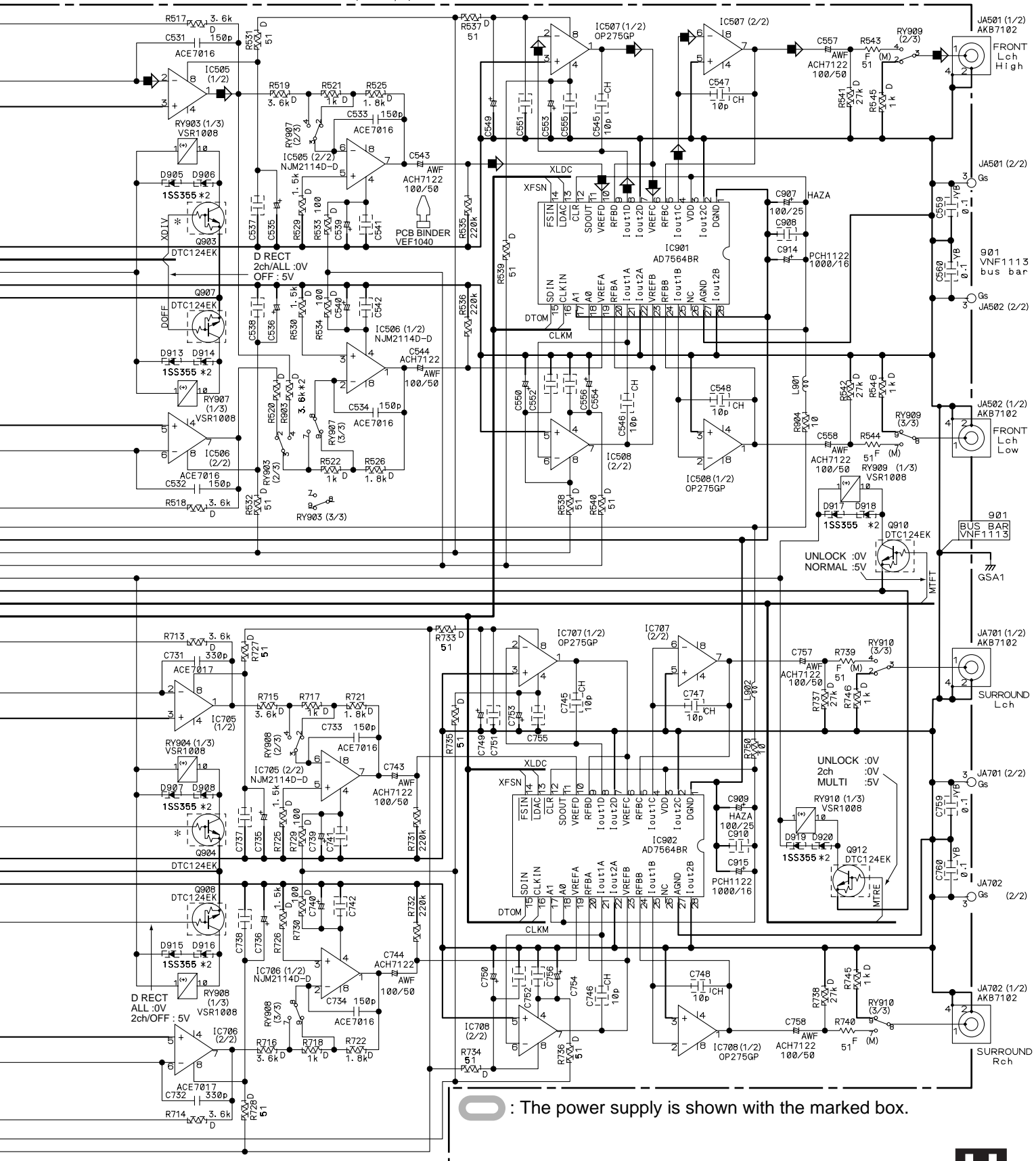

◻ : The power supply is shown with the marked box.



NOTES

IMPORTANT PARTS FOR SAFETY FERRITES RTF1167

CAPACITORS

Unmarked Unit : μF CENA101M25 (100μF/25V) PCH1128 (220μF/25V) CKSQYB473K50 (0.047μF)

RESISTORS : Ω

RS1/10S□□□□□ RN1/10SE□□□□□ RDR1/4PM□□□□□ RDM1/2PC□□□□□

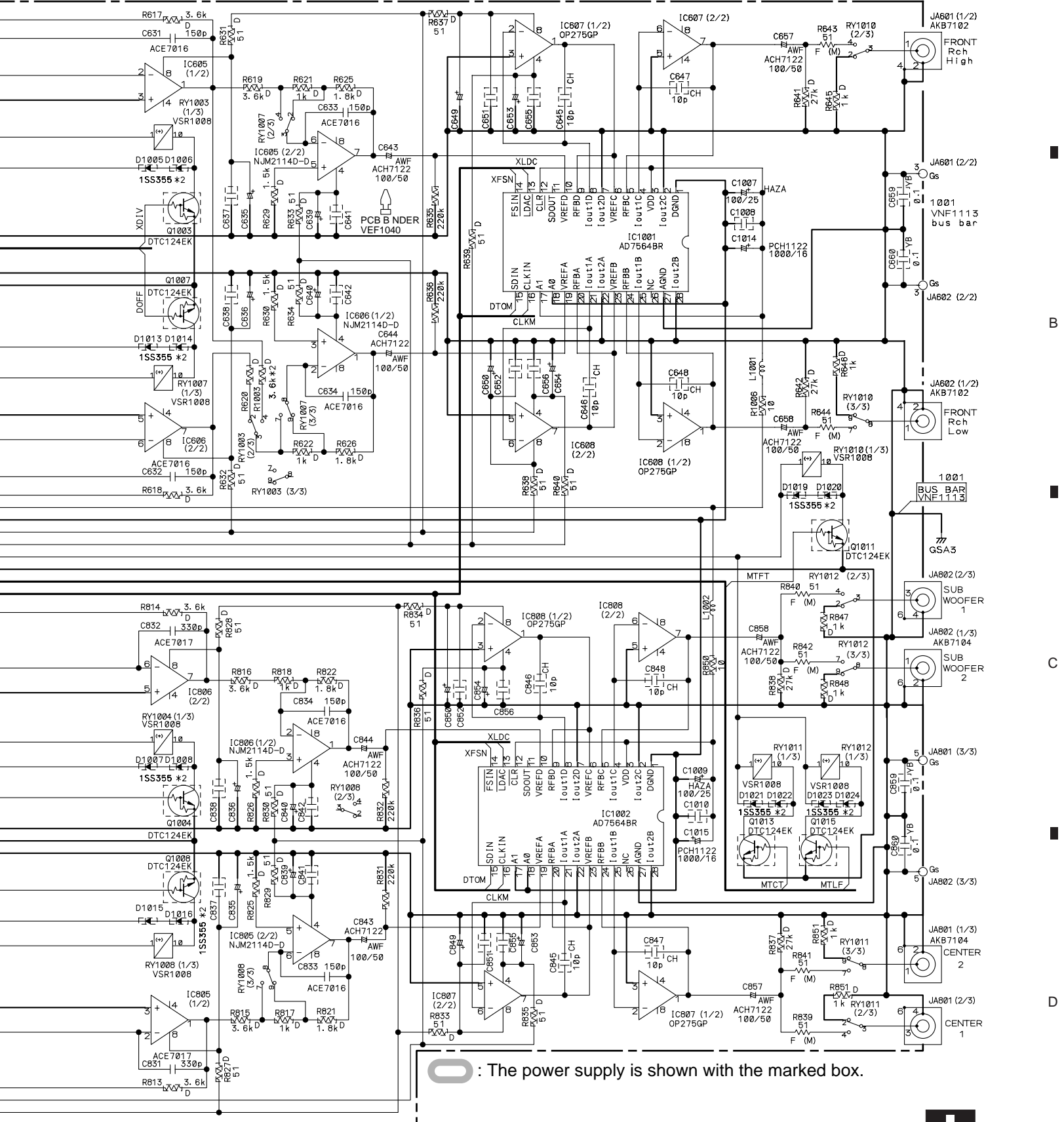

The power supply is shown with the marked box.

A B C D

3.16 DISPLAY, VOLUME, ENC A, INPUT SW and ENC B ASSYS

J DISPLAY ASSY (AWX7305)

A

B

C

D

C CN202

G 1/6 CN2108

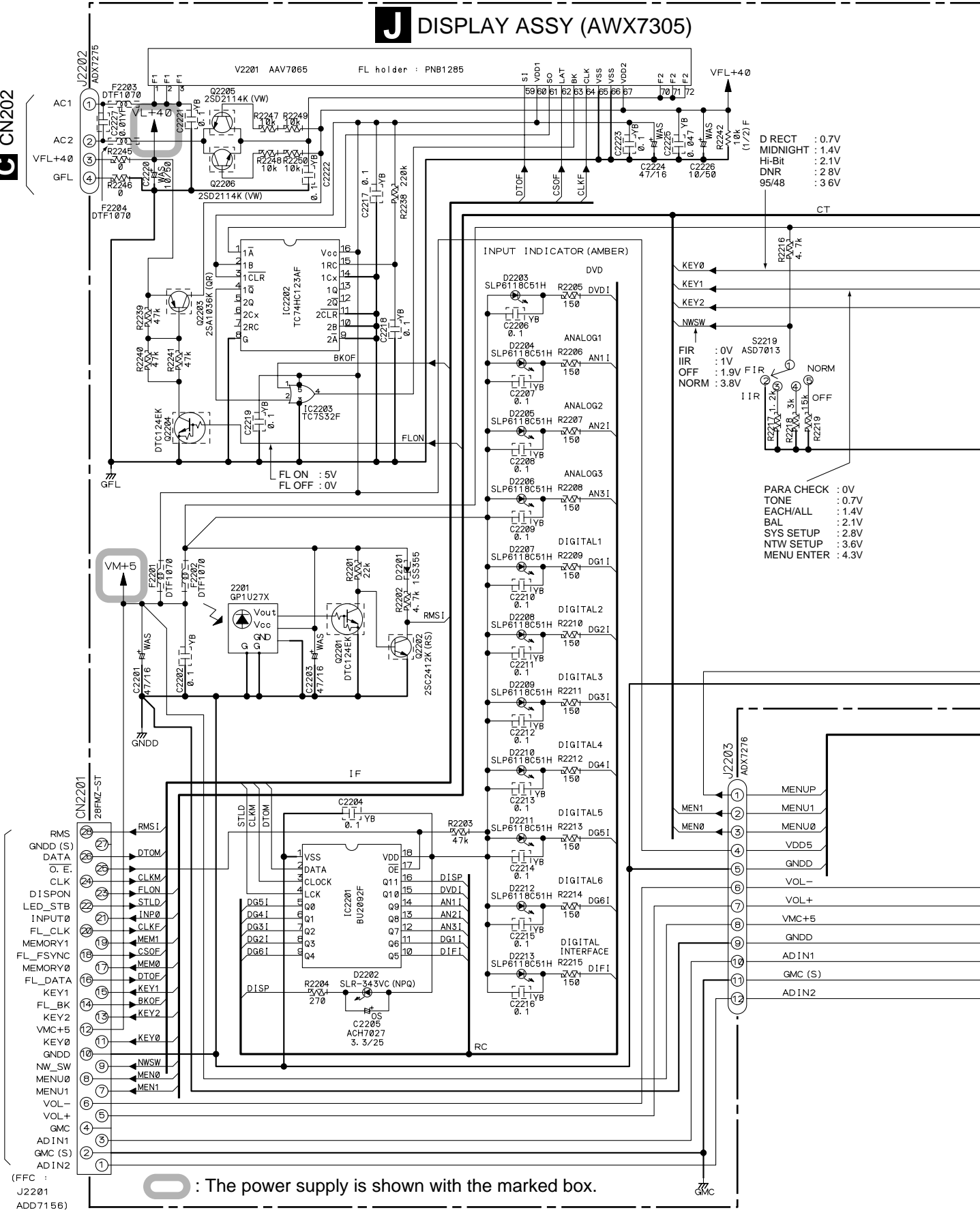

D RECT : 0.7V
MIDNIGHT : 1.4V
H-Bit : 2.1V
DNR : 2.8V
95/48 : 3.6V

PARA CHECK : 0V
TONE : 0.7V
EACH/ALL : 1.4V
BAL : 2.1V
SYS SETUP : 2.8V
NTW SETUP : 3.6V
MENU ENTER : 4.3V

O : The power supply is shown with the marked box.



DISPLAY ASSY

- S2202 : PARAMETER CHECK
- S2203 : □/D/TS
- S2204 : DIRECT
- S2205 : TONE
- S2206 : DIMMER
- S2207 : MIDNIGHT
- S2208 : EACH/ALL
- S2209 : DVD INPUT 2ch/multi
- S2210 : Hi-bit
- S2211 : BALANCE
- S2212 : INPUT GAIN
- S2213 : DIGITAL NR
- S2214 : SYSTEM SETUP
- S2215 : REC SELECTOR (DIGITAL)
- S2216 : fs (96k/48k)
- S2217 : NETWORK SETUP
- S2218 : CHARACTER INPUT
- S2219 : OUTPUT MODE
- FIR - IIR - OFF - NORM

INPUT SW ASSY

- S2301 : INPUT SELECTOR
- ENC A ASSY
- S2401 : SOUND MEMORY (PUSH NEXT/ENTER)
- ENC B ASSY
- S2501 : MULTI CONTROL (PUSH NEXT/ENTER)

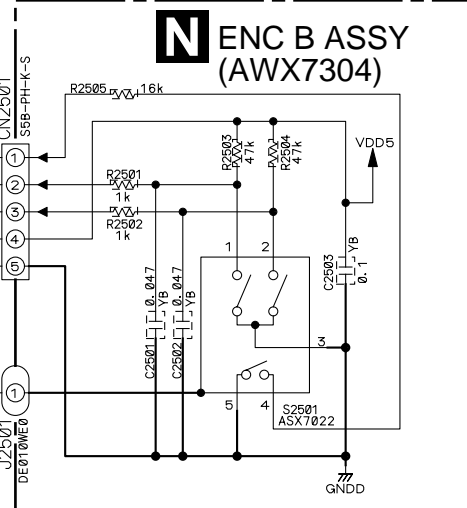
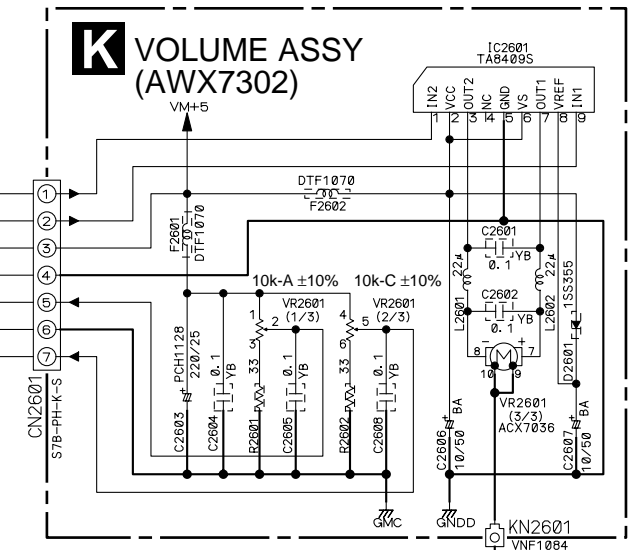
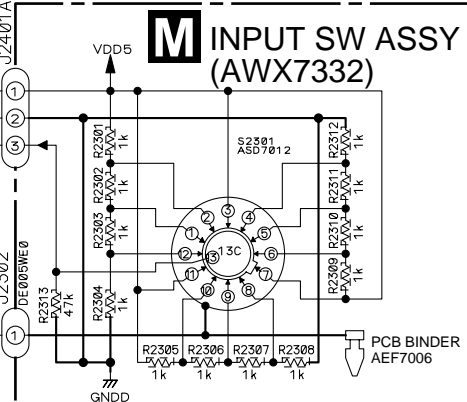
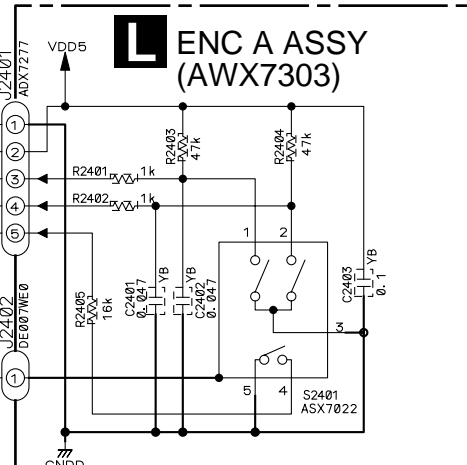
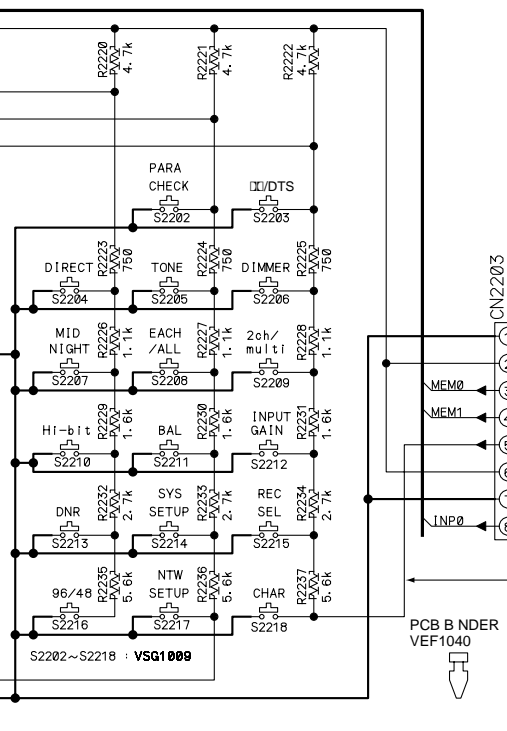

NOTES

INDUCTORS Unmarked Unit : μH
 LFEAL00J

WAVEFORMS

Note : The encircled numbers denote measuring point in the schematic diagram.

Measurement condition :

No. 1-1	: DIGITAL OUT, fs = 96kHz	No. 7 and 9	: ANALOG IN
No. 1-2	: DIGITAL OUT, fs = 48kHz		(data support to 16 through 24 bit.)
No. 2 and 3	: DIGITAL IN, fs = 96kHz, 20 bit	No. 8, 10 to 13	: ANALOG IN
	(data support to 16 through 24 bit.)		(DIGITAL IN is the same)
No. 4	: ANALOG IN	No. 17	: DIRECT : ON at full scale output
No. 5, 14 to 16	: ANALOG IN, multi	No. 12-2	: ANALOG IN at DIGITAL IN (96k, 48k, 192k)
No. 6	: ANALOG IN		
	(24 bit data output with Hi-bit "ON" at DIGITAL IN)		

A DIGITAL I/O ASSY

G DSP ASSY

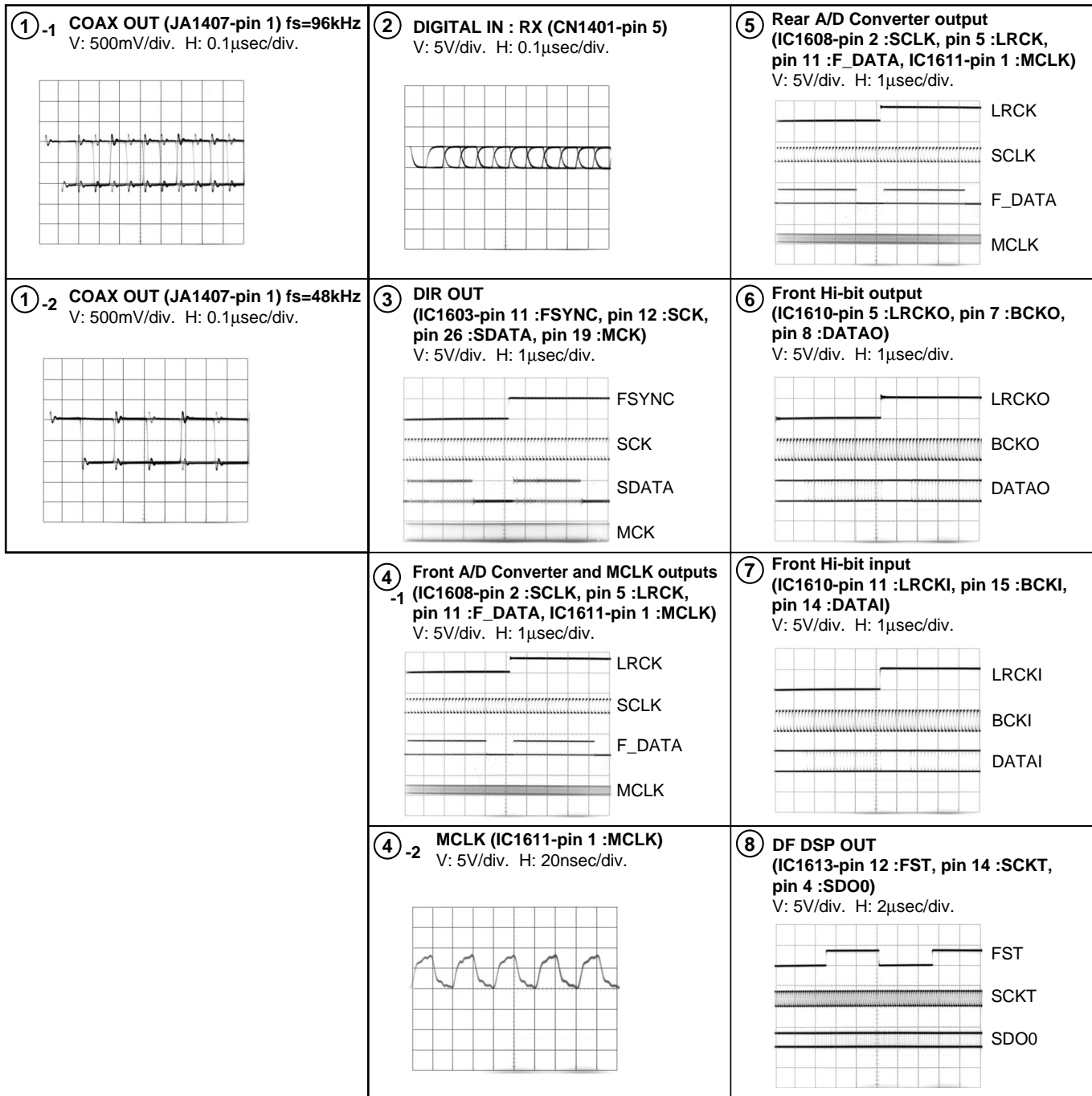

H AUDIO A ASSY

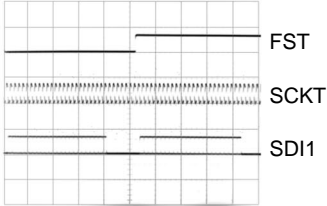
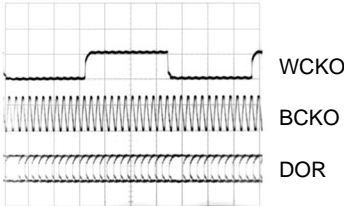
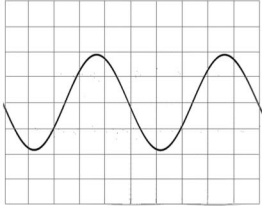
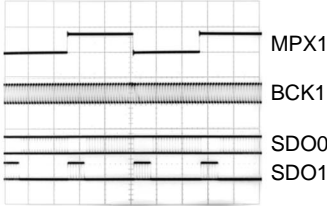
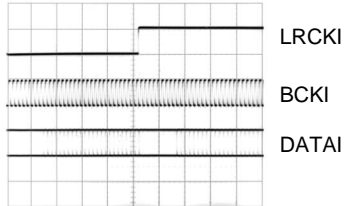
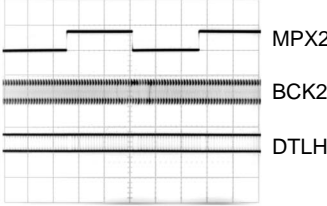
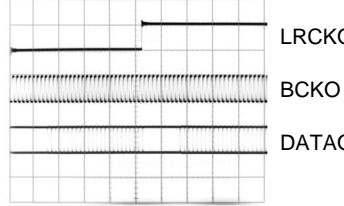
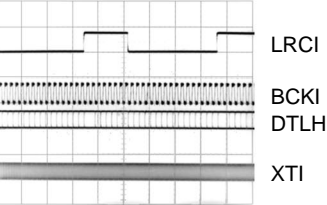
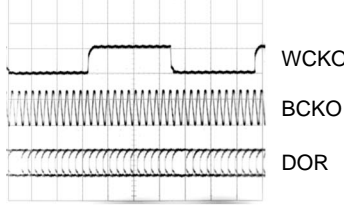
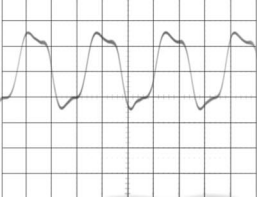
<p>⑨ Center DSP input (IC1501-pin 12 :FST, pin 14 :SCKT, pin 10 :SDI1) V: 5V/div. H: 1μsec/div.</p> 	<p>⑬ Front DF output (IC1703-pin 4 :WCKO, pin 5 :BCKO, pin 2 :DOR) V: 5V/div. H: 0.2μsec/div.</p> 	<p>⑰ DAC output (f=1kHz) (IC503-pin 1) V: 5V/div. H: 0.2msec/div.</p> 
<p>⑩ Front 1st DSP output (IC1701-pin 12 :MPX1, pin 14 :BCK1, pin 4 :SDO0, pin 5 :SDO1) V: 5V/div. H: 2μsec/div.</p> 	<p>⑭ Rear Hi-bit input (IC1901-pin 11 :LRCKI, pin 14 :DATAI, pin 15 :BCKI) V: 5V/div. H: 1μsec/div.</p> 	
<p>⑪ Front 2nd DSP output (IC1702-pin 12 :MPX2, pin 14 :BCK2, pin 4 :DTLH) V: 5V/div. H: 2μsec/div.</p> 	<p>⑮ Rear Hi-bit output (IC1901-pin 5 :LRCKO, pin 7 :BCKO, pin 8 :DATAO) V: 5V/div. H: 1μsec/div.</p> 	
<p>⑫-1 Front DF input (IC1703-pin 19 :LRCKI, pin 21 :BCKI, pin 27 :DTLH, pin 16 :XTI(37MHz)) V: 5V/div. H: 1μsec/div.</p> 	<p>⑯ Rear DF output (IC1902-pin 23 :DOR, pin 25 :WCKO, pin 26 :BCKO) V: 5V/div. H: 0.2μsec/div.</p> 	
<p>⑫-2 Front DF input XTI (37MHz) (IC1703-pin 16 : XTI(37MHz)) V: 5V/div. H: 10nsec/div.</p> 		

4. PCB CONNECTION DIAGRAM

4.1 AC, PS ASSYS

A

B AC ASSY

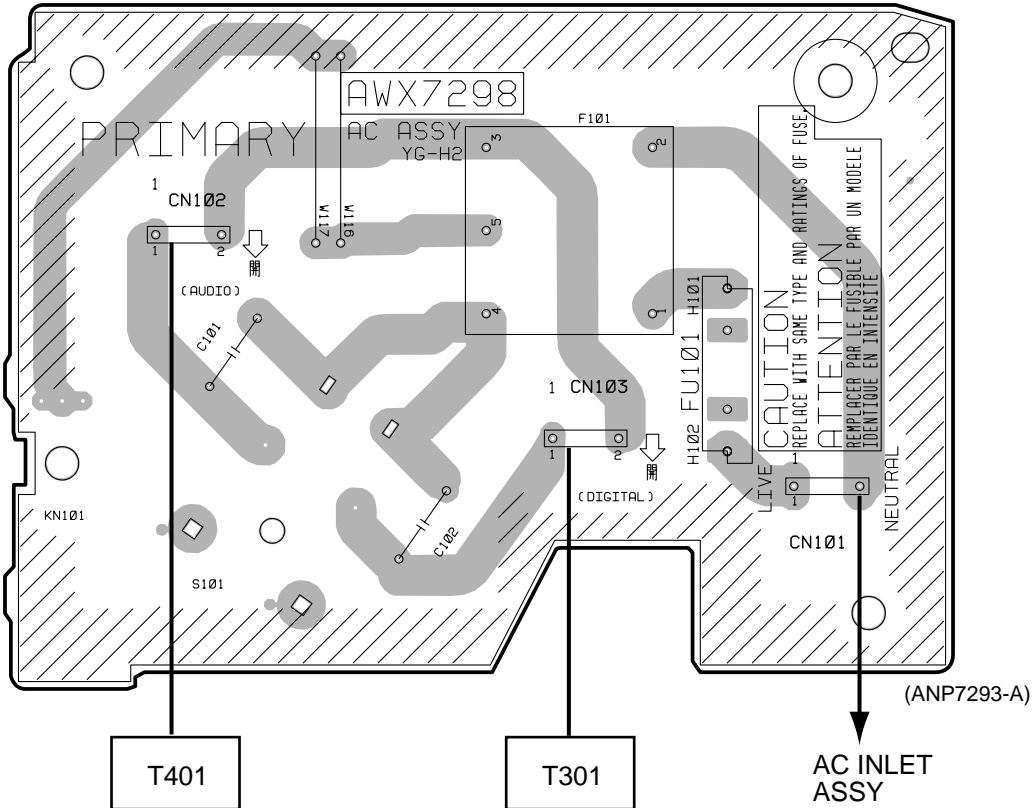

B

E CN405 - CN407

C PS ASSY

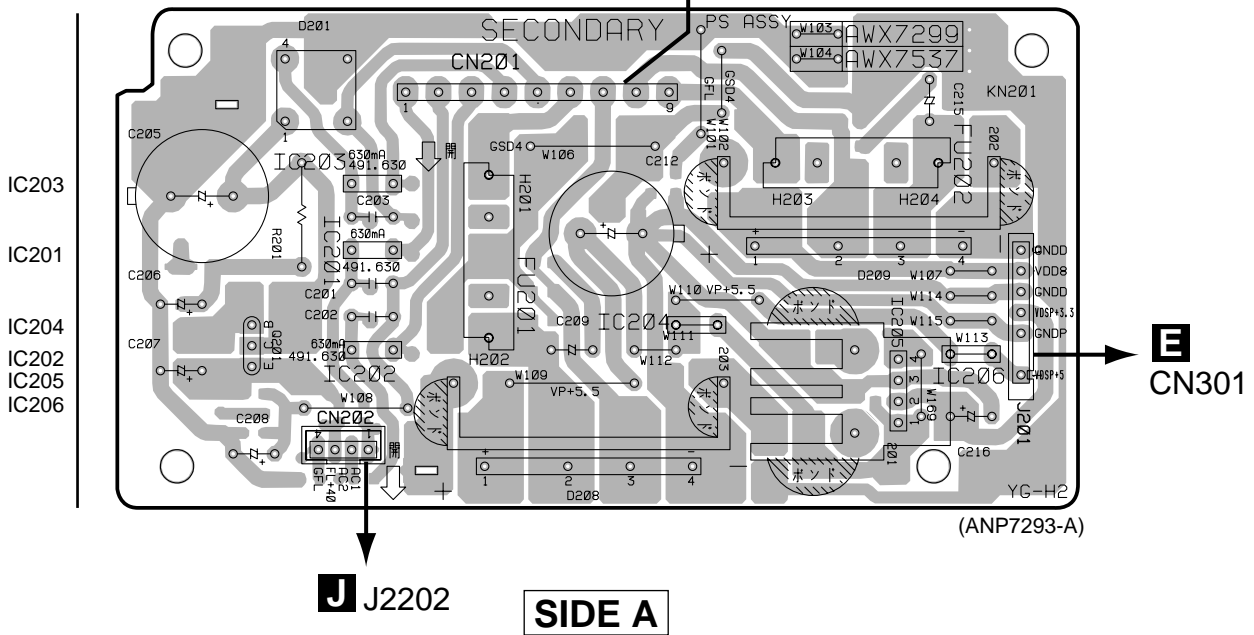

C

J J2202

SIDE A

NOTE FOR PCB DIAGRAMS :

1. Part numbers in PCB diagrams match those in the schematic diagrams.
2. A comparison between the main parts of PCB and schematic diagrams is shown below.

Symbol In PCB Diagrams	Symbol In Schematic Diagrams	Part Name
		Transistor
		Transistor with resistor
		Field effect transistor
		Resistor array
		3-terminal regulator

3. The parts mounted on this PCB include all necessary parts for several destinations.
For further information for respective destinations, be sure to check with the schematic diagram.
4. View point of PCB diagrams.

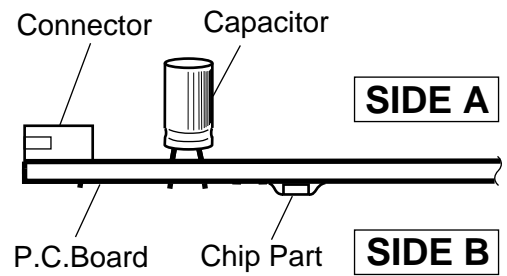

C PS ASSY

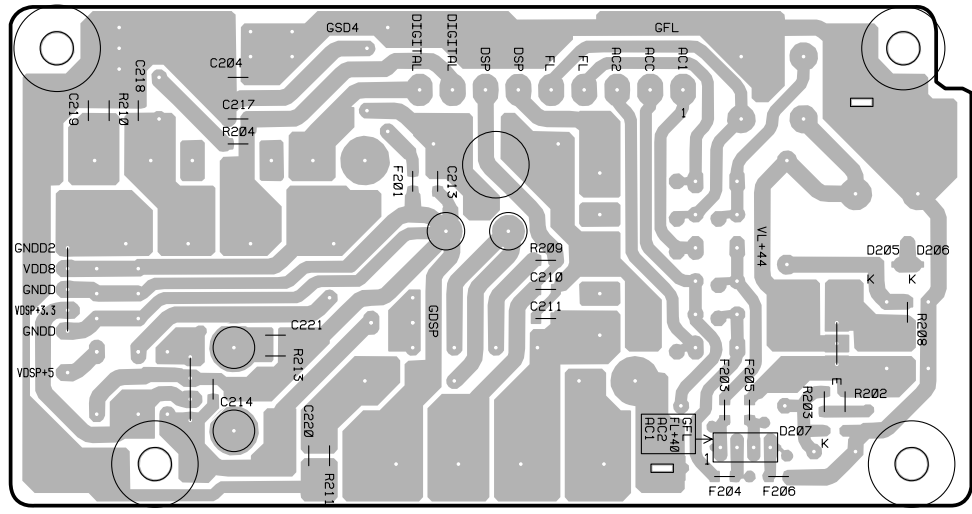

(ANP7293-A)

SIDE B

4.2 DIGITAL I/O ASSY

A DIGITAL I/O ASSY

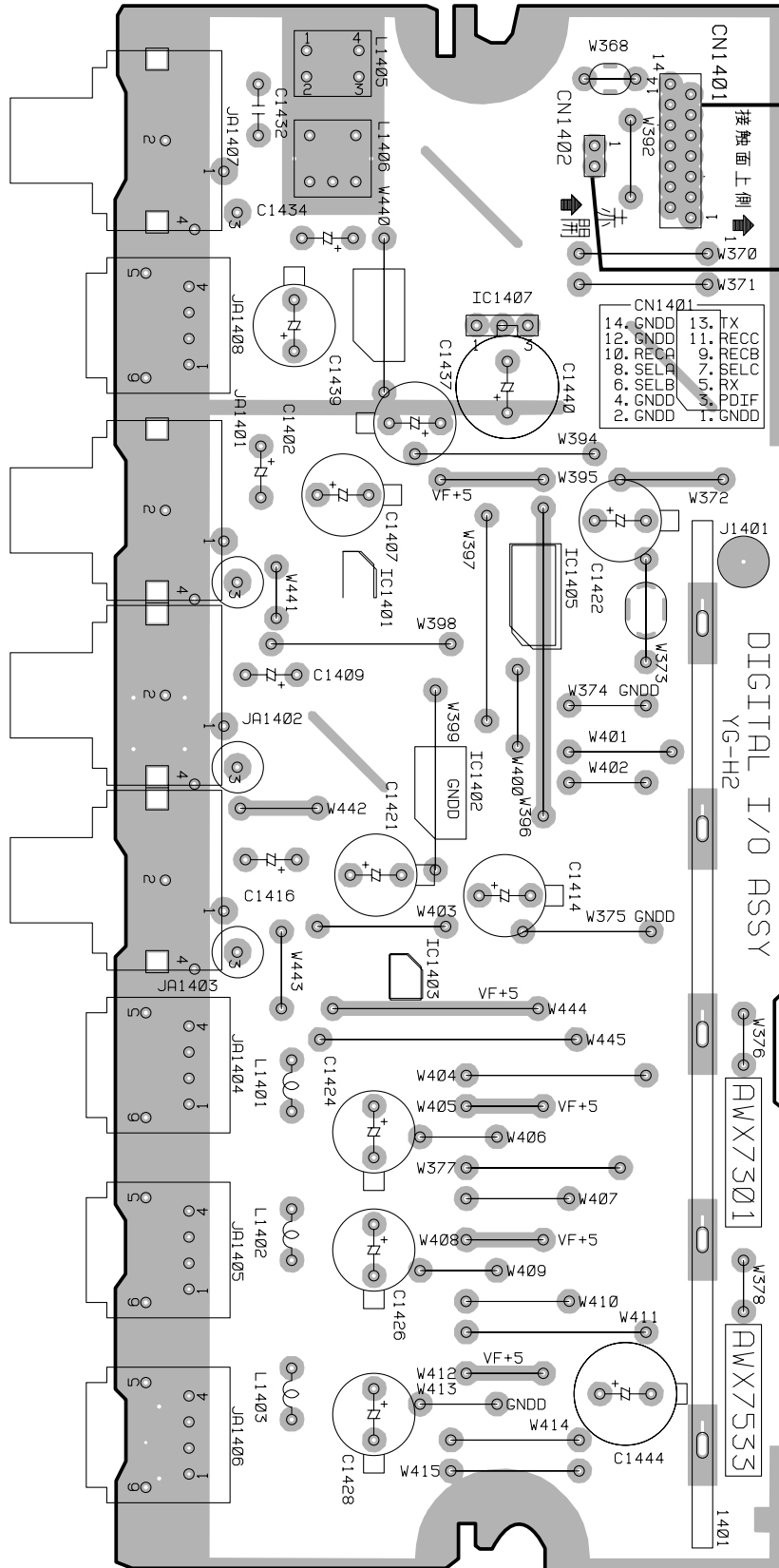

G CN1601

E J301- pins 1, 2

SIDE A

(ANP7292-B)

A DIGITAL I/O ASSY

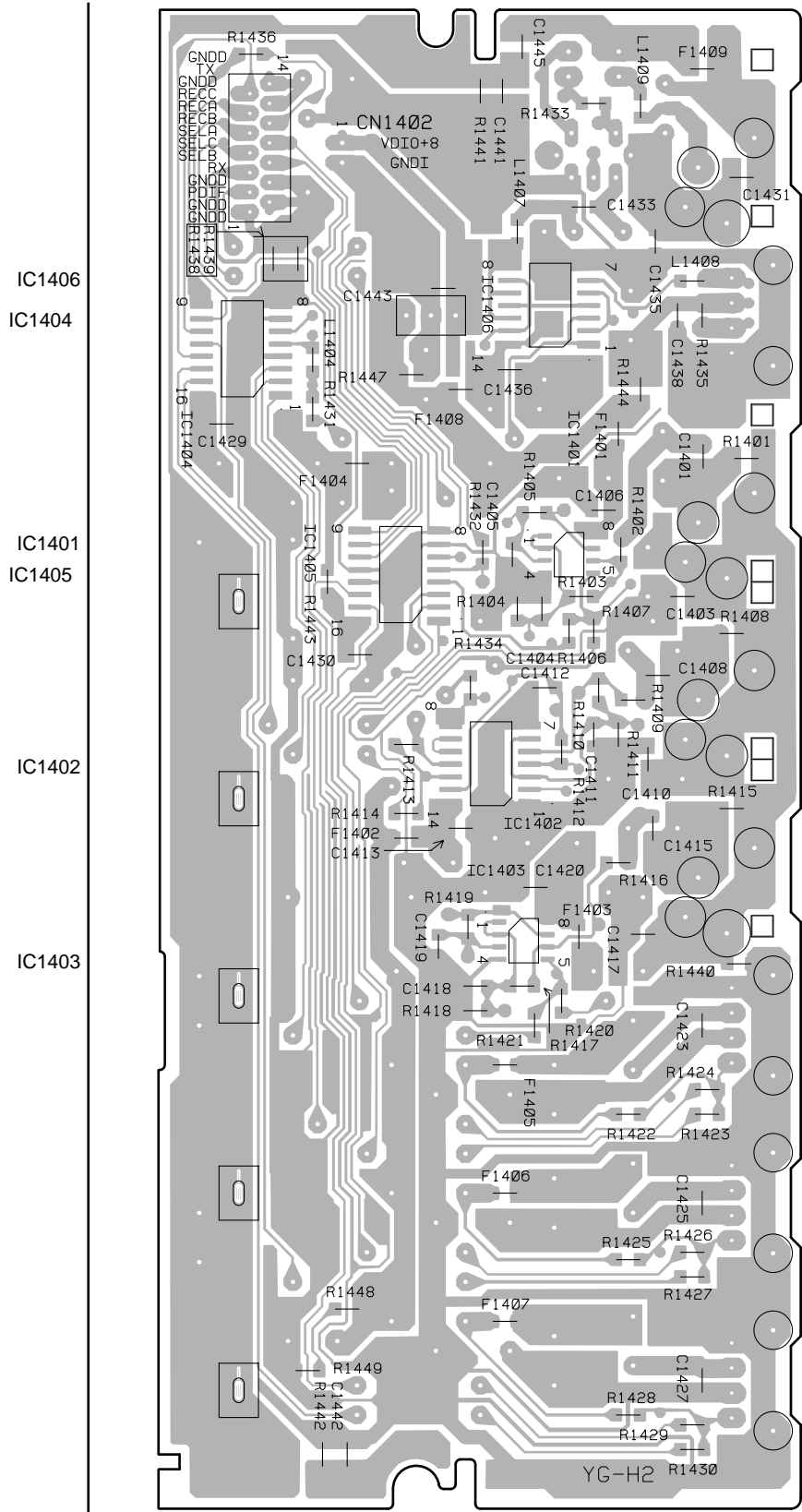

IC1406
IC1404

IC1401
IC1405

IC1402

IC1403

(ANP7292-B)

SIDE B



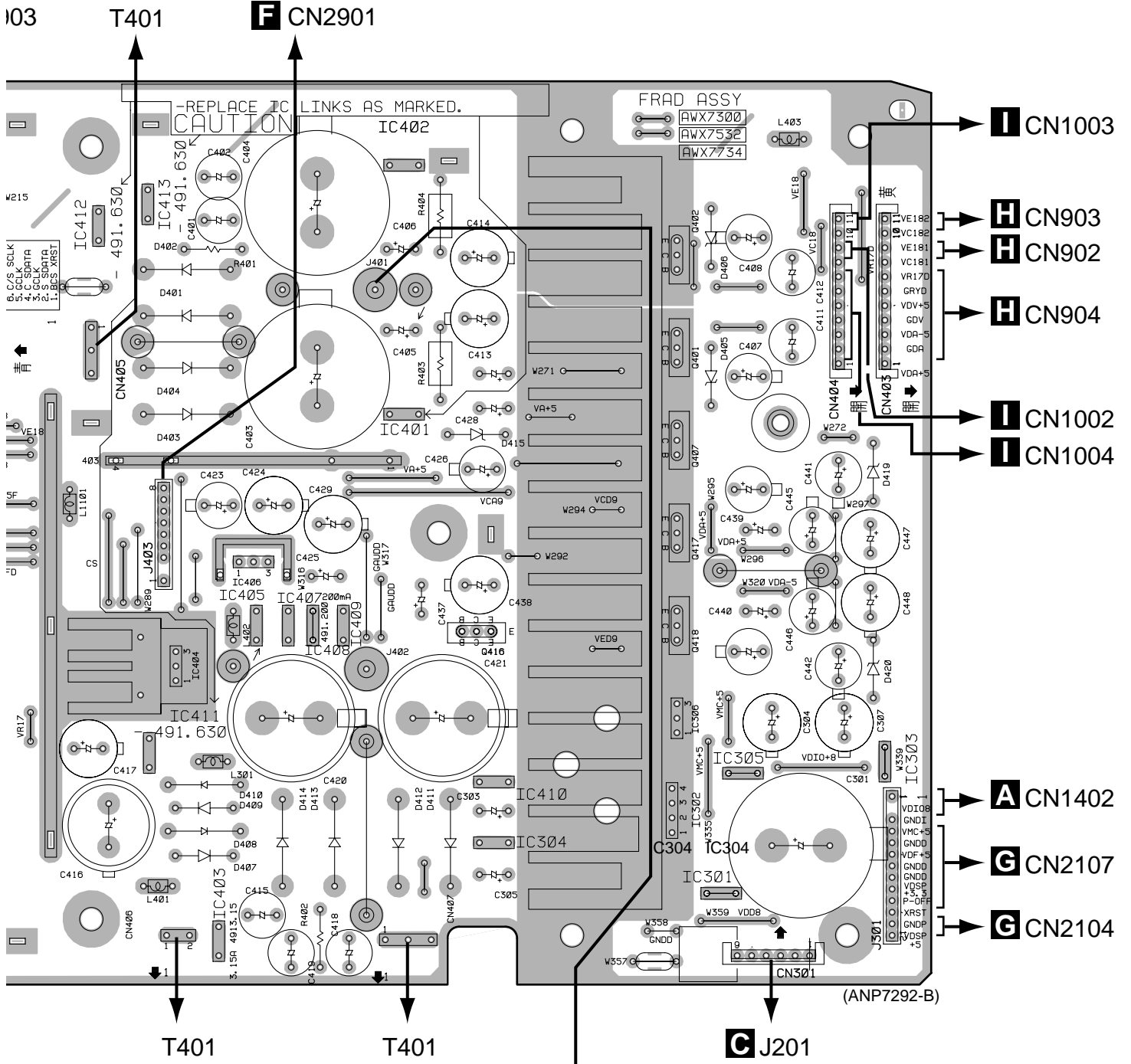

I03

T401

F CN2901

I CN1003

H CN903

H CN902

H CN904

I CN1002

I CN1004

A CN1402

G CN2107

G CN2104

T401

T401

G J201

IC412 IC413 IC1405 - IC1409

IC404

IC411 IC403

IC402 Q416

IC401 IC410

IC304

Q402 Q401

Q407 Q417

Q418 IC306

IC302 IC305

IC301

IC303

D SG ASSY

(ANP7292-B)

DE

E FRAD ASSY

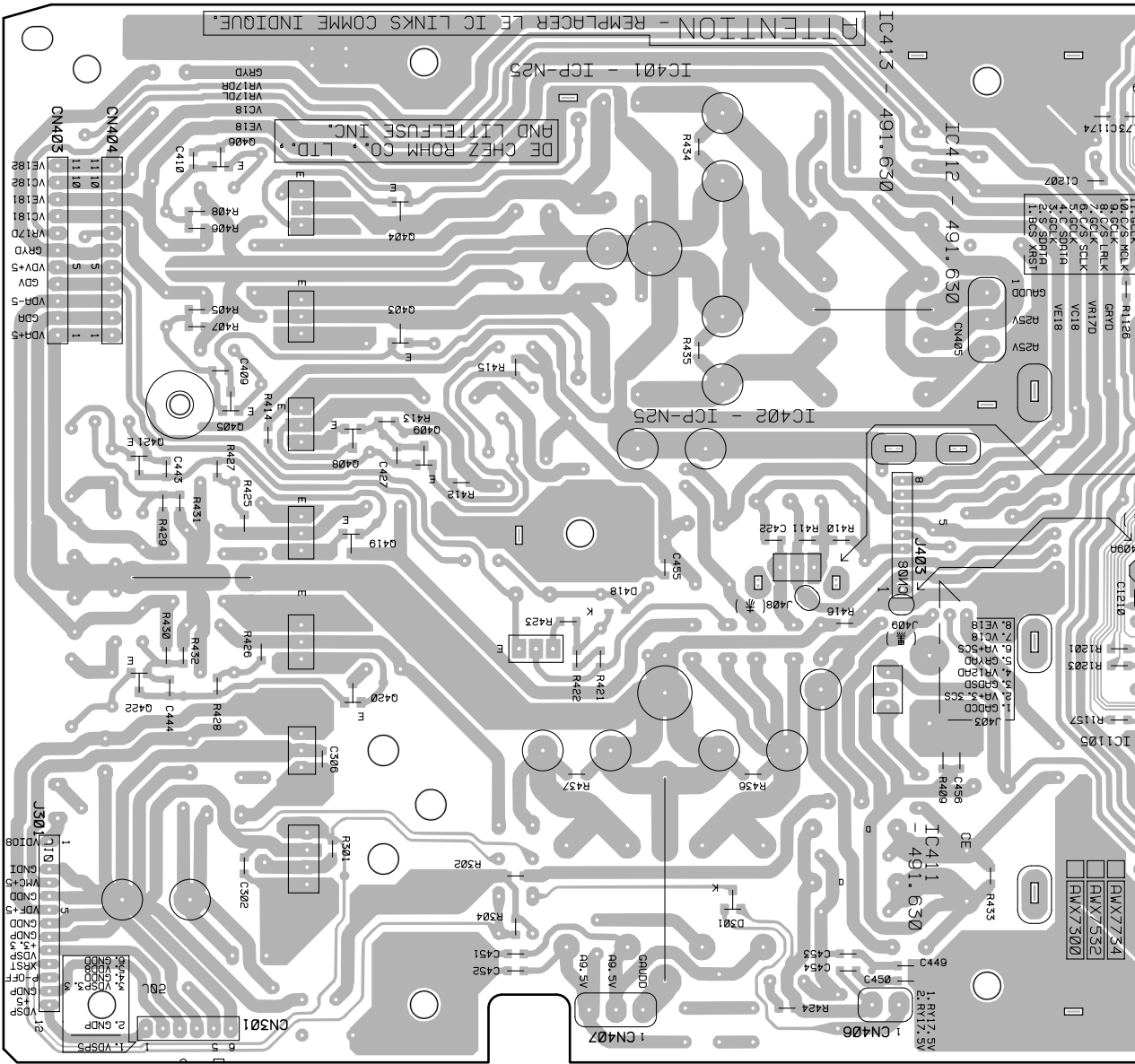

- Q421
- Q406
- Q408
- Q404
- Q419
- Q403
- Q422
- Q420
- Q409

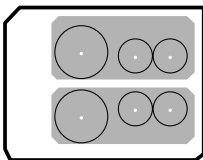

D
SG ASSY

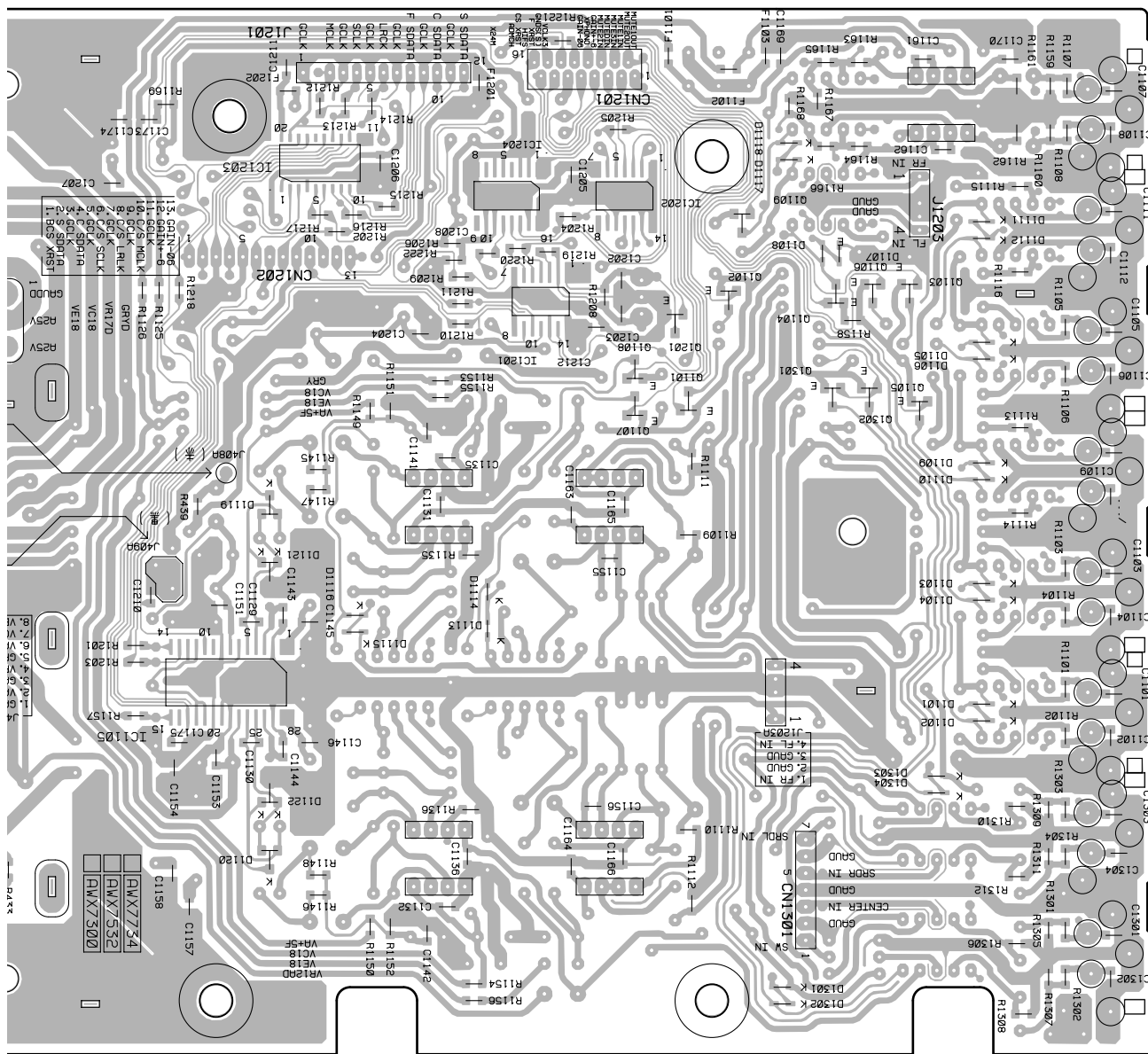

(ANP7292-B)

IC1105

IC1203

IC1204

IC1202

IC1201

Q1108 Q1201

Q1107 Q1101

Q1109

Q1102

Q1104

Q1301

Q1106

Q1302

Q1103

Q1105

SIDE B



4.4 CRAD ASSY

A

B

C

D

F CRAD ASSY

E CN1202

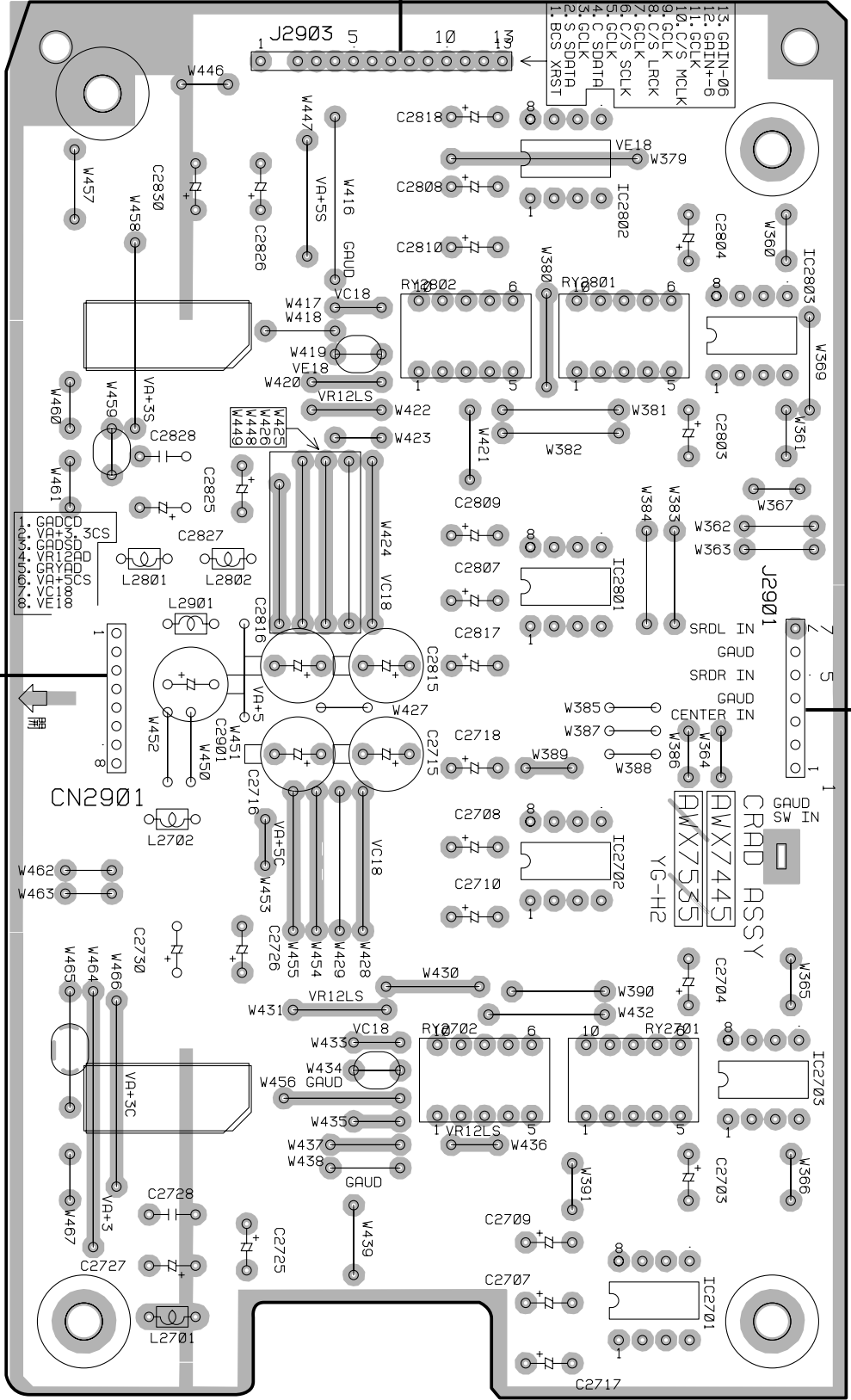

IC2802

IC2803

IC2801

IC2702

IC2703

IC2701

E CN1301

E J403

(ANP7292-B)

SIDE A



F CRAD ASSY

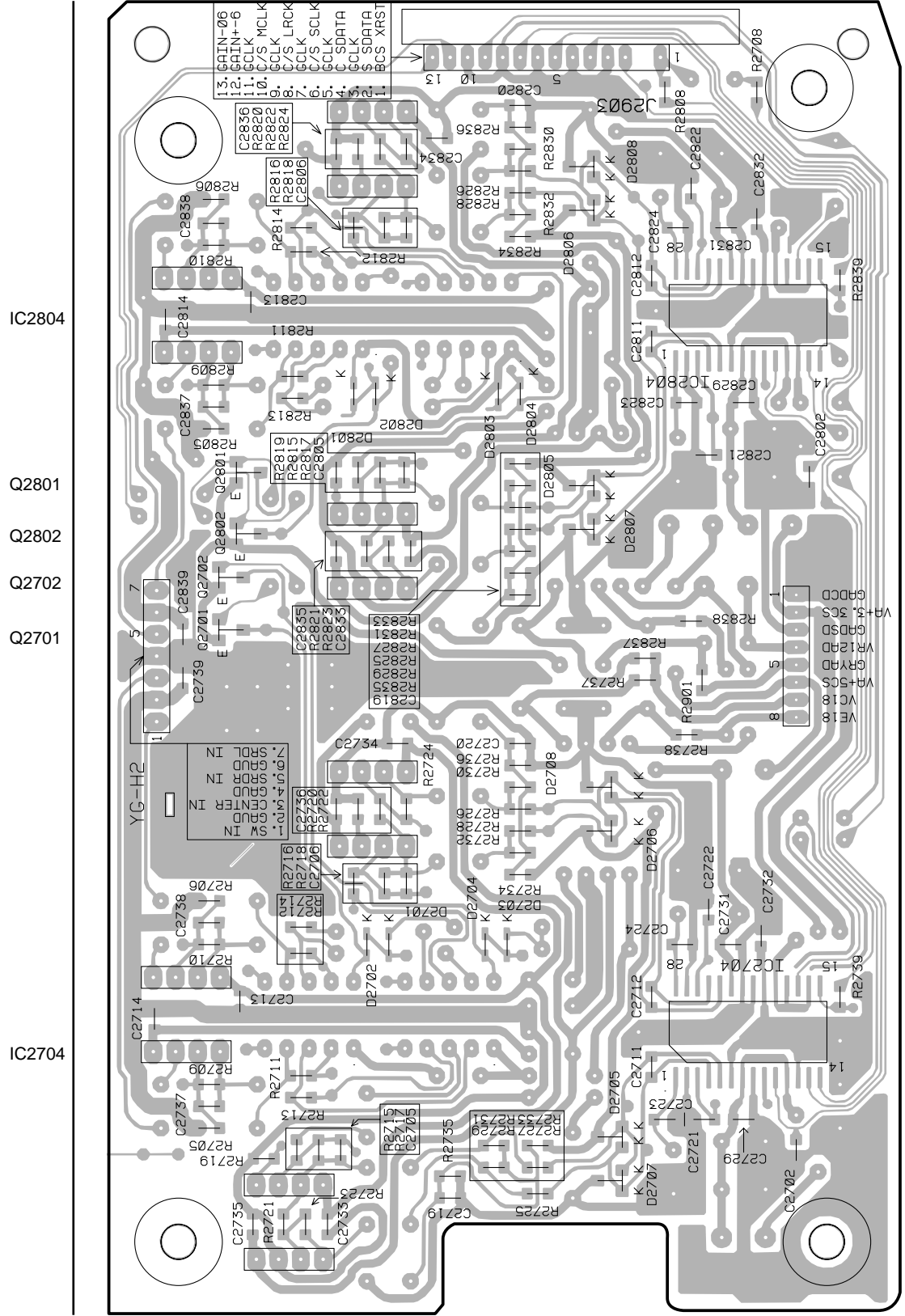

SIDE B

(ANP7292-B)



4.5 DSP ASSY

G DSP ASSY

A

E J1201 **E** CN1201 **H** J902

B

C

D

A

CN1401

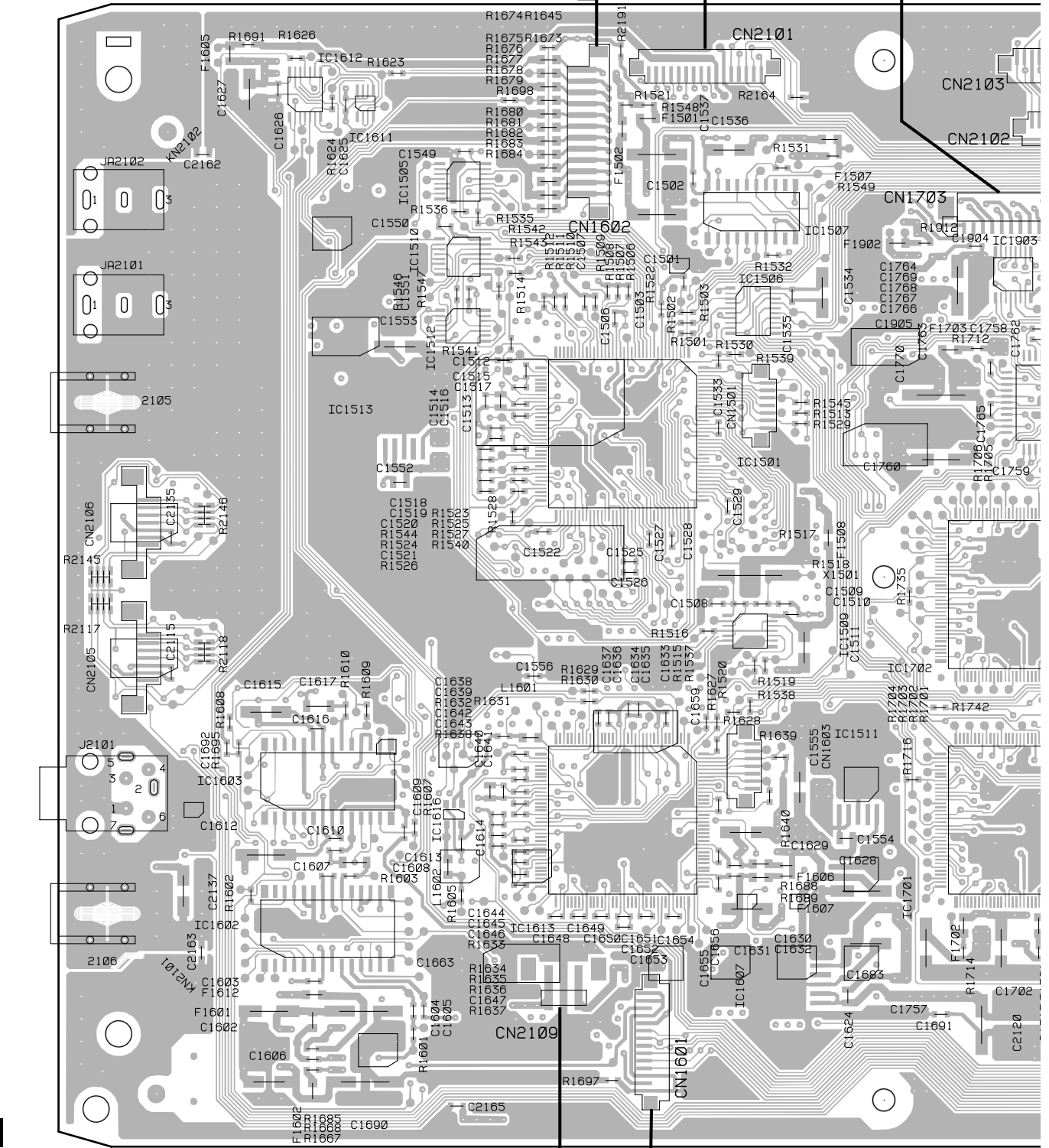

SIDE A

IC1612 IC1611 IC1505 IC1501 IC1507 IC1509 IC1702 IC19
 IC1513 IC1510 IC1512 IC1506 IC1511 IC1701 IC19
 IC1603 IC1602 IC1616 IC1613 IC1607



902 **I** CN1001 **H** CN901 **I** J1002

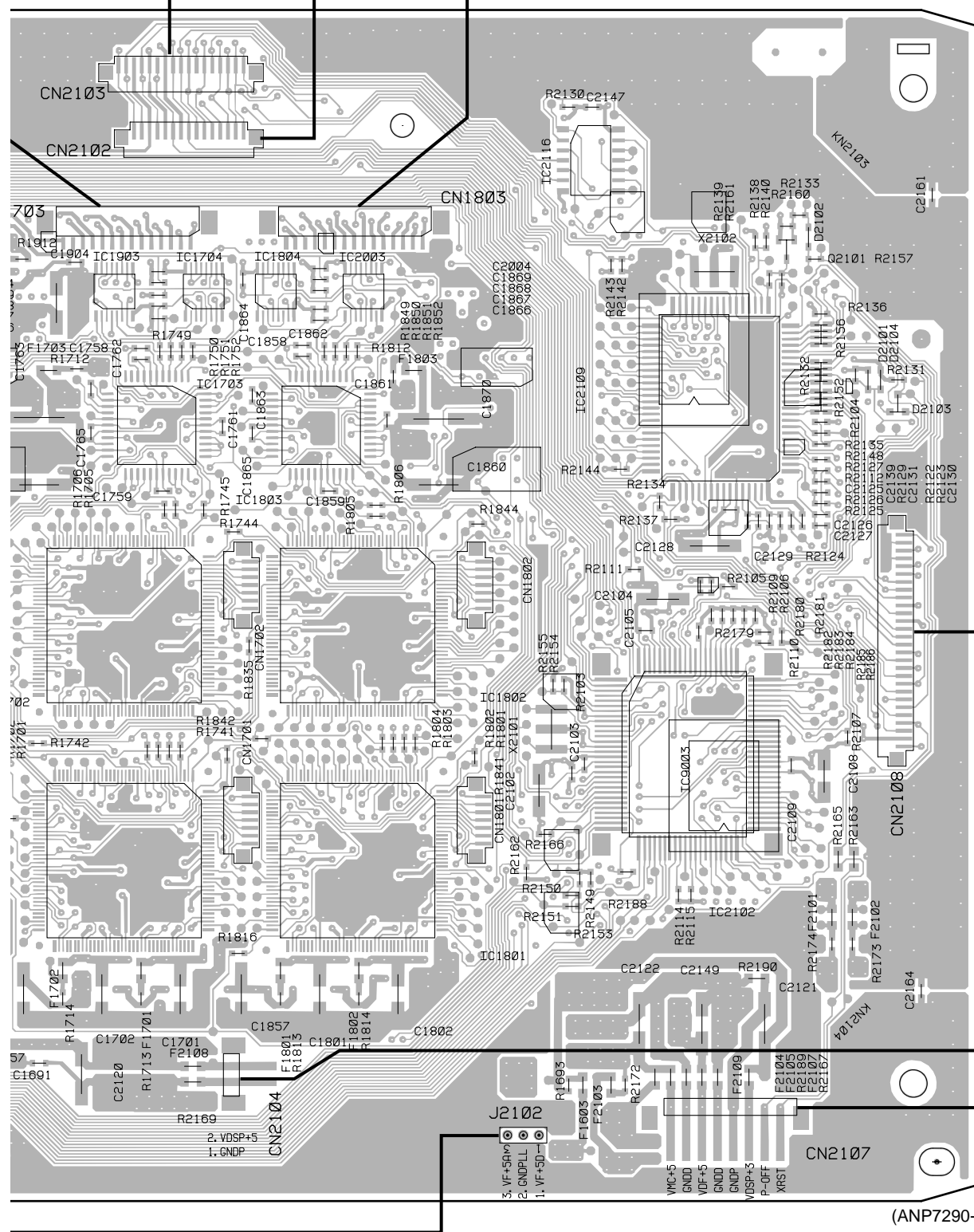

IC1702 IC1903 IC1704 IC1804 IC2003 IC2116 IC2109 Q2101
 IC1701 IC1703 IC1803 IC1802 IC9003 IC2102
 IC1801

J CN2201

E J301

(ANP7290-E)



DSP ASSY

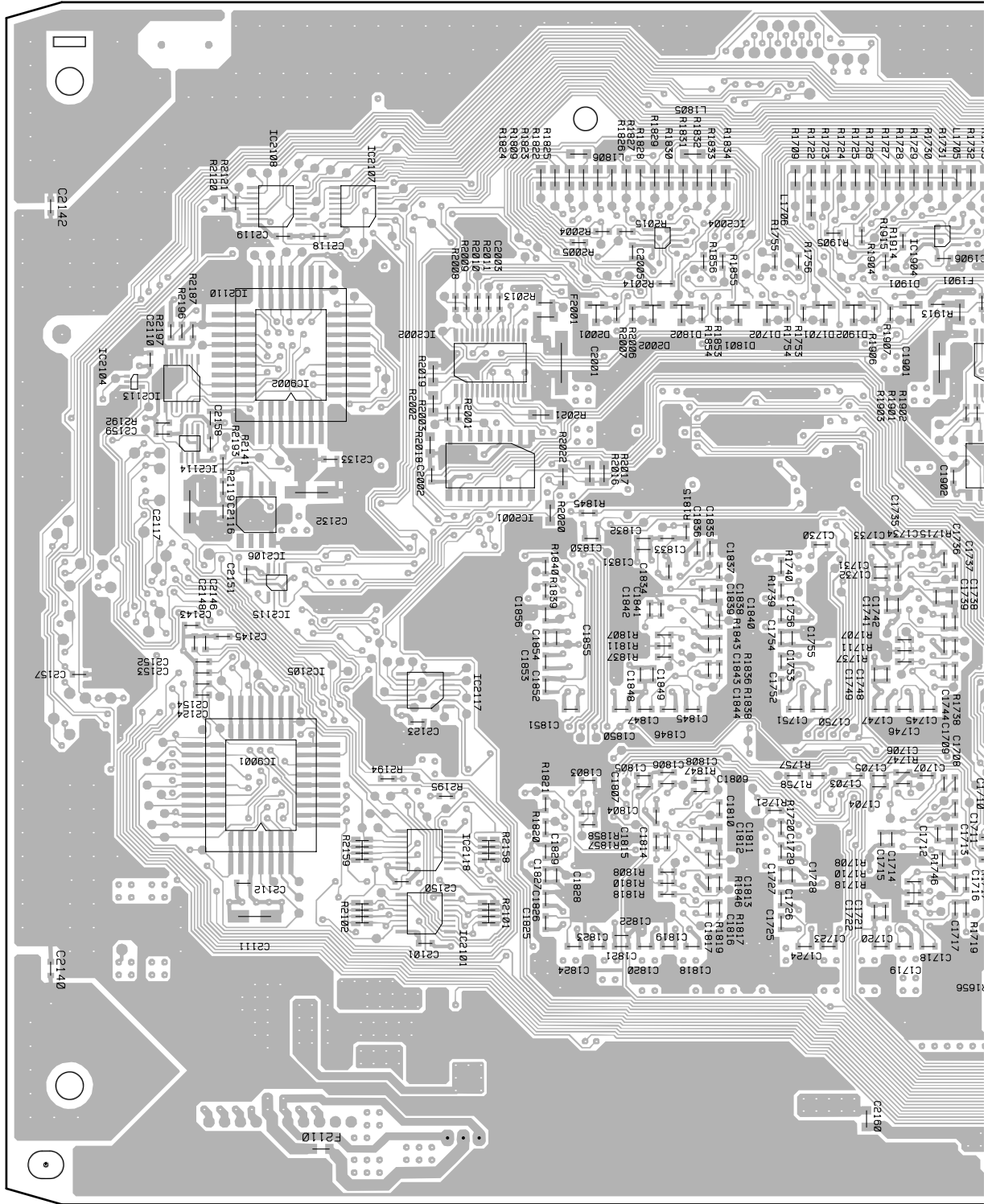

- | | | | | | |
|--------|--------|--------|--------|--------|-----|
| IC2104 | IC2113 | IC2108 | IC2107 | IC2002 | IC1 |
| | IC2110 | IC9002 | IC2118 | IC2001 | IC1 |
| | IC2114 | IC2106 | IC2101 | | |
| | IC9001 | IC2115 | | | |

SIDE B



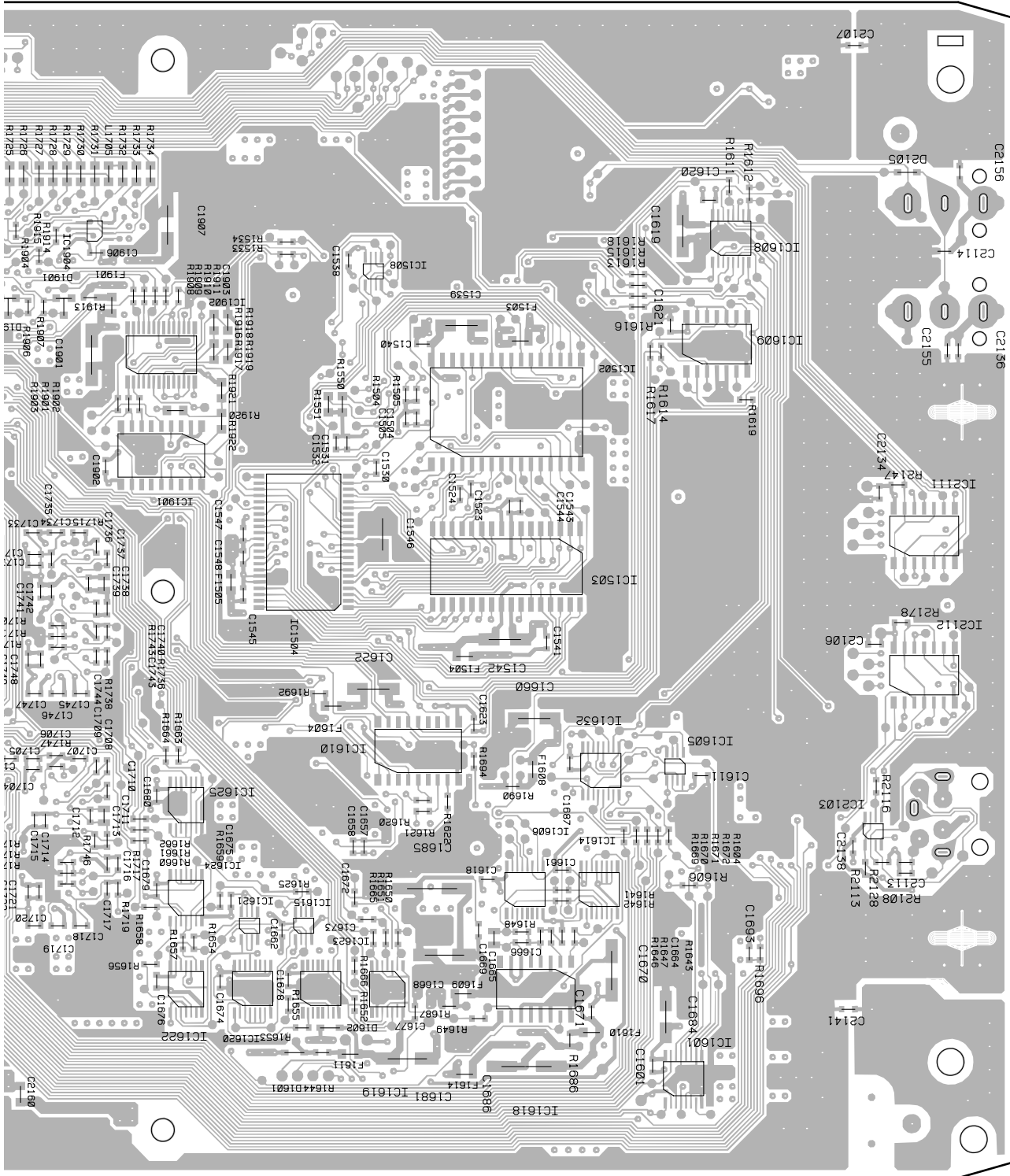

(ANP7290-E)

IC1902	IC1504	IC1508	IC1502	IC1503	IC1608	IC1609	IC2111
IC1901							IC2112
IC1625		IC1610			IC1632	IC1605	IC2103
IC1624	IC1621	IC1615		IC1606	IC1614	IC1601	
IC1622	IC1620	IC1623	IC1619	IC1618			



4.6 AUDIO A ASSY

A

B

C

D

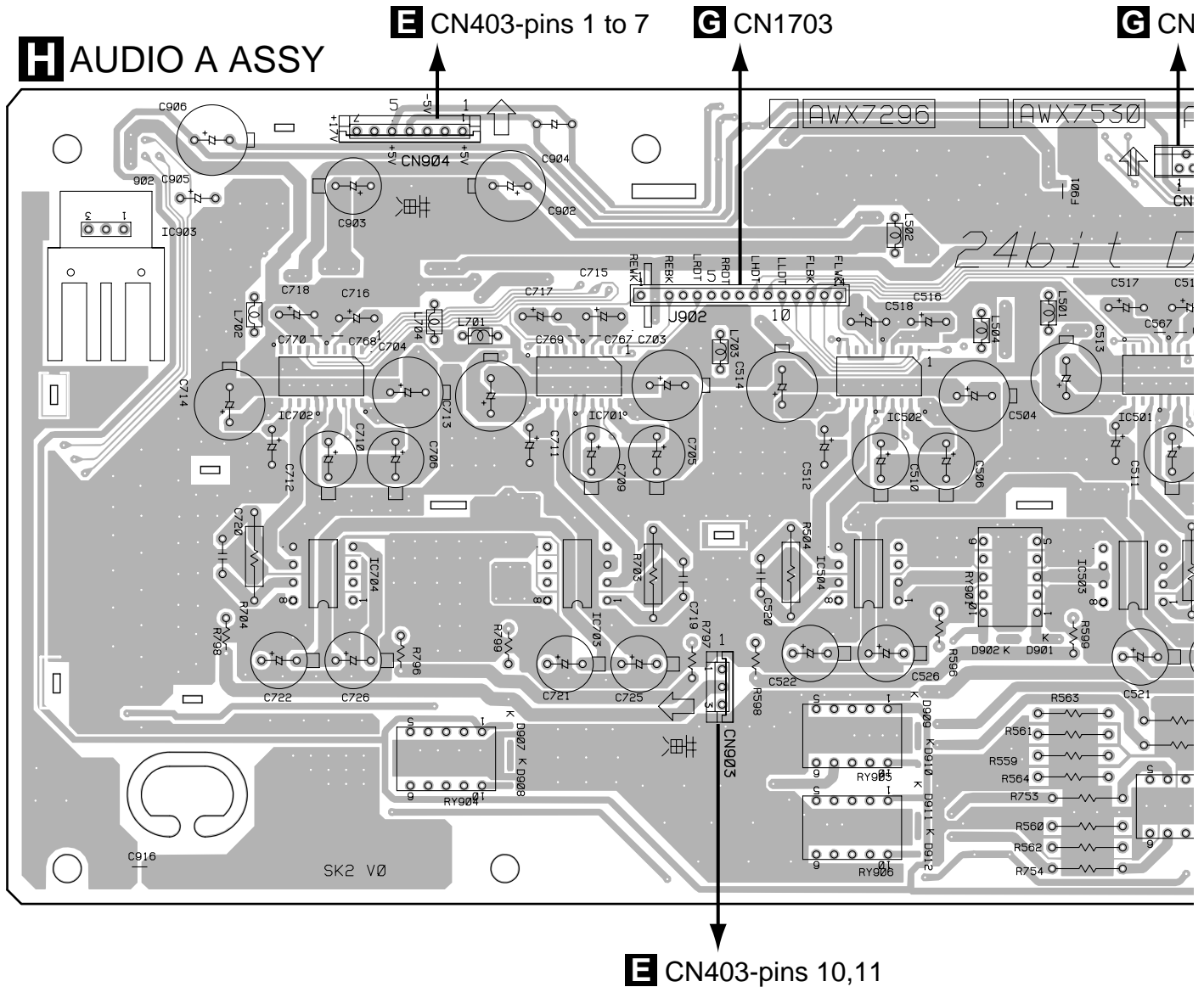

IC903

IC702
IC704

IC701
IC703

IC502
IC504

IC501
IC503

SIDE A



A

G CN2102

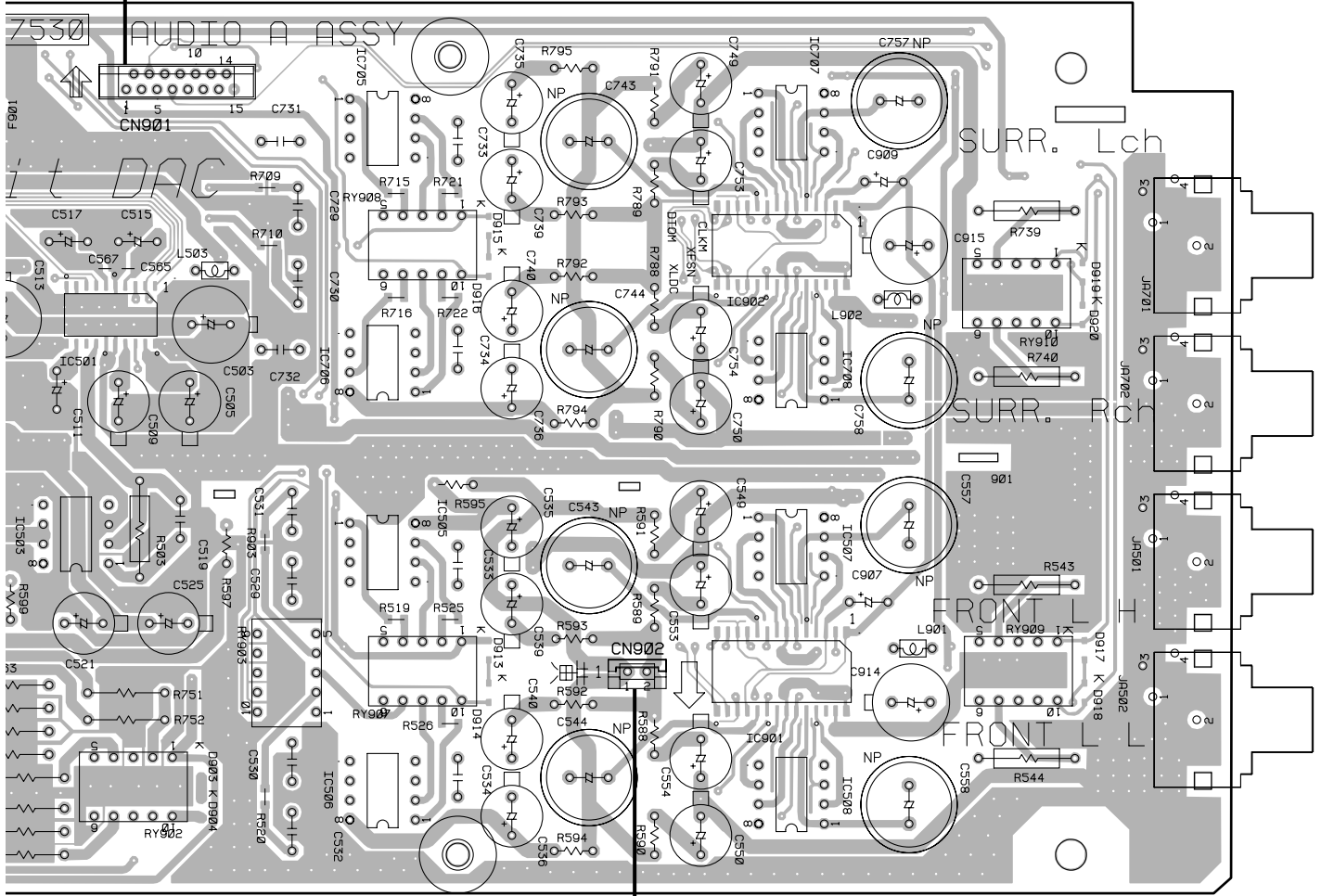

B

C

(ANP7291-D)

E CN403-pins 8,9

IC501	IC705	IC902	IC707
IC503	IC706	IC901	IC708
	IC505		IC507
	IC506		IC508

D

AUDIO A ASSY

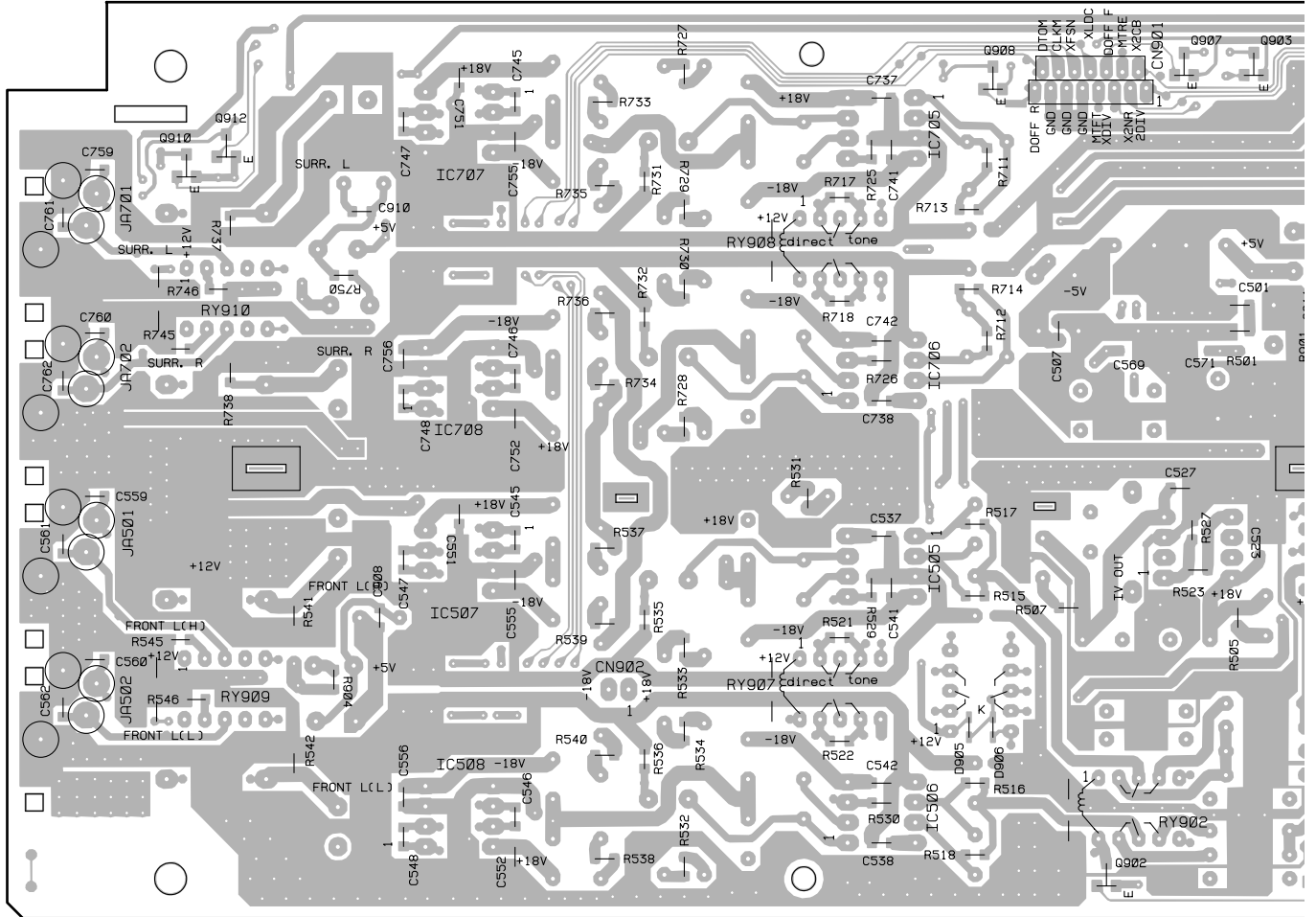

Q910 Q912

Q908

Q907 Q903

Q902

Q901

SIDE B



A

B

C

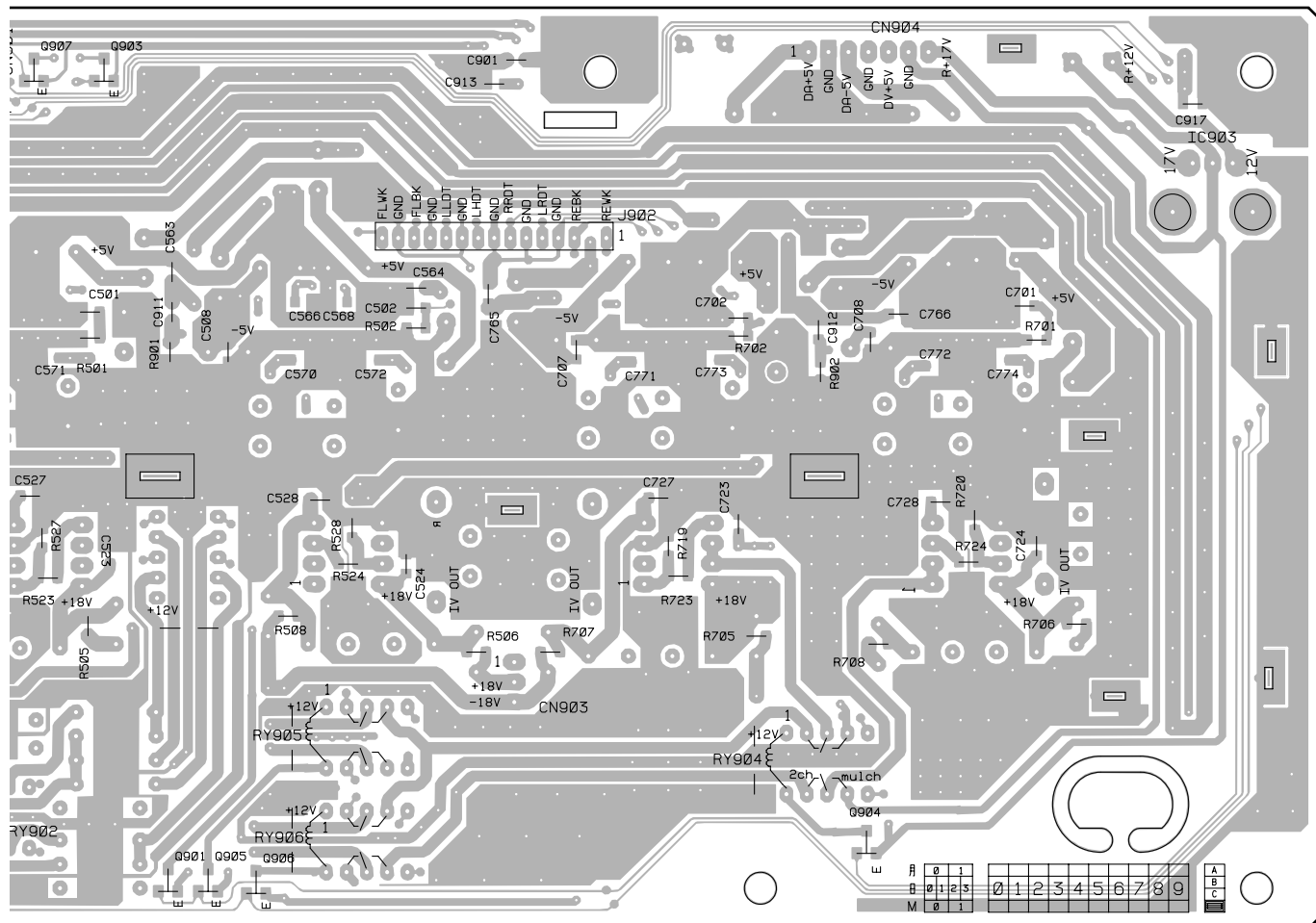

(ANP7291-D)

907 Q903

Q901 Q905 Q906

Q904

D



4.7 AUDIO B ASSY

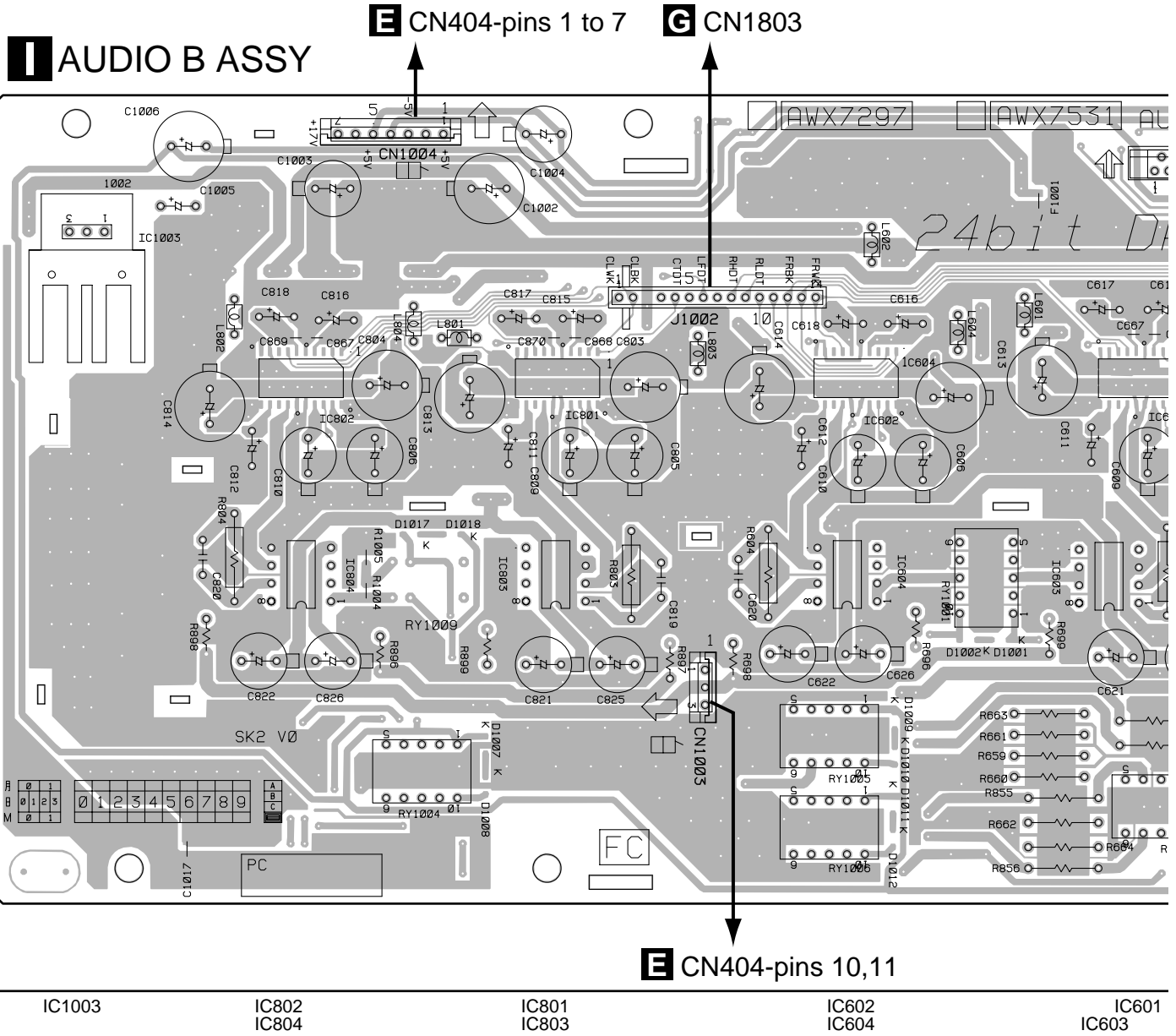

SIDE A

A

B

C

G CN2103

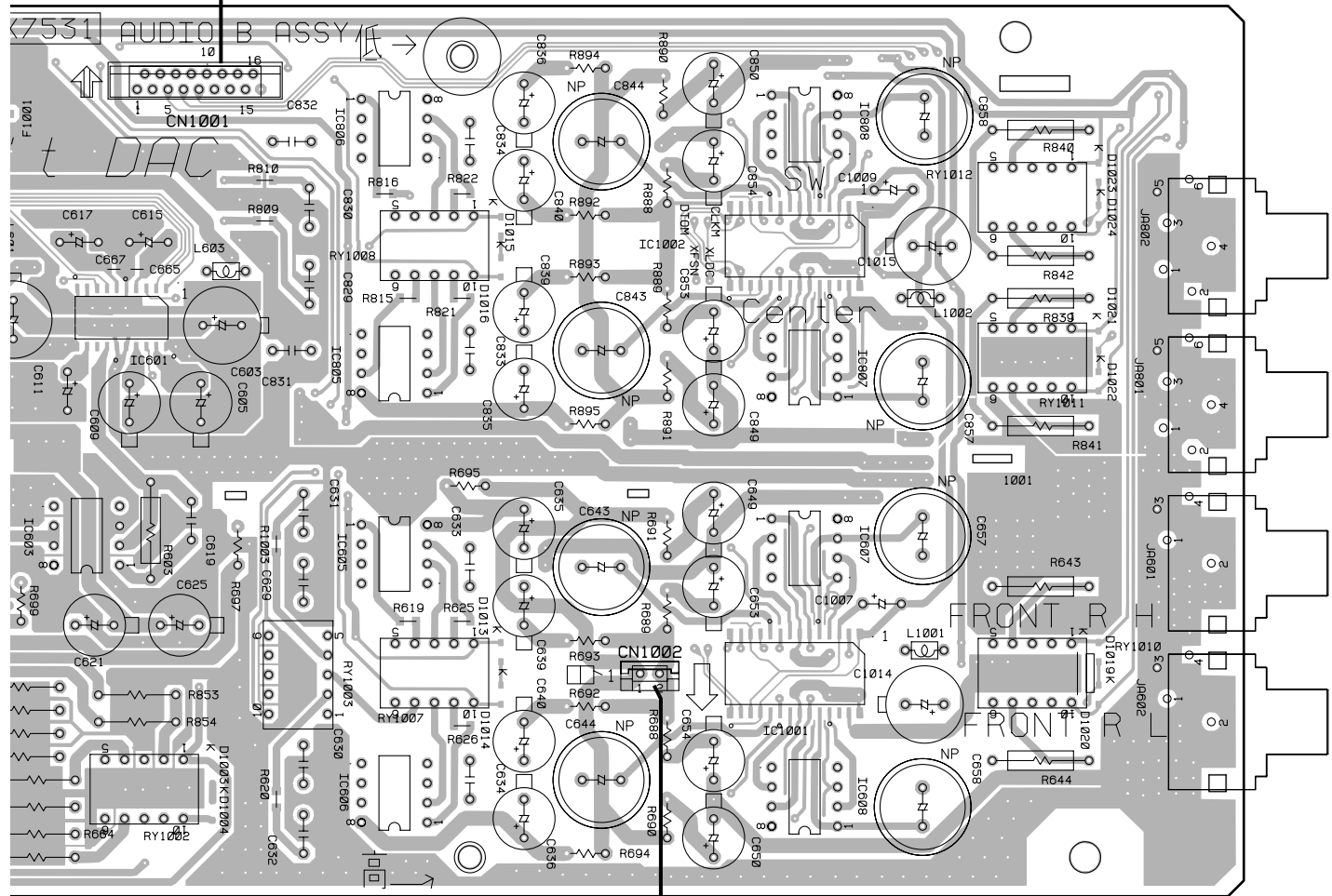

(ANP7291-D)

E CN404-pins 8,9

IC601
IC603

IC805
IC806
IC605
IC606

IC808
IC1002 IC807
IC1001 IC607
IC608

D



AUDIO B ASSY

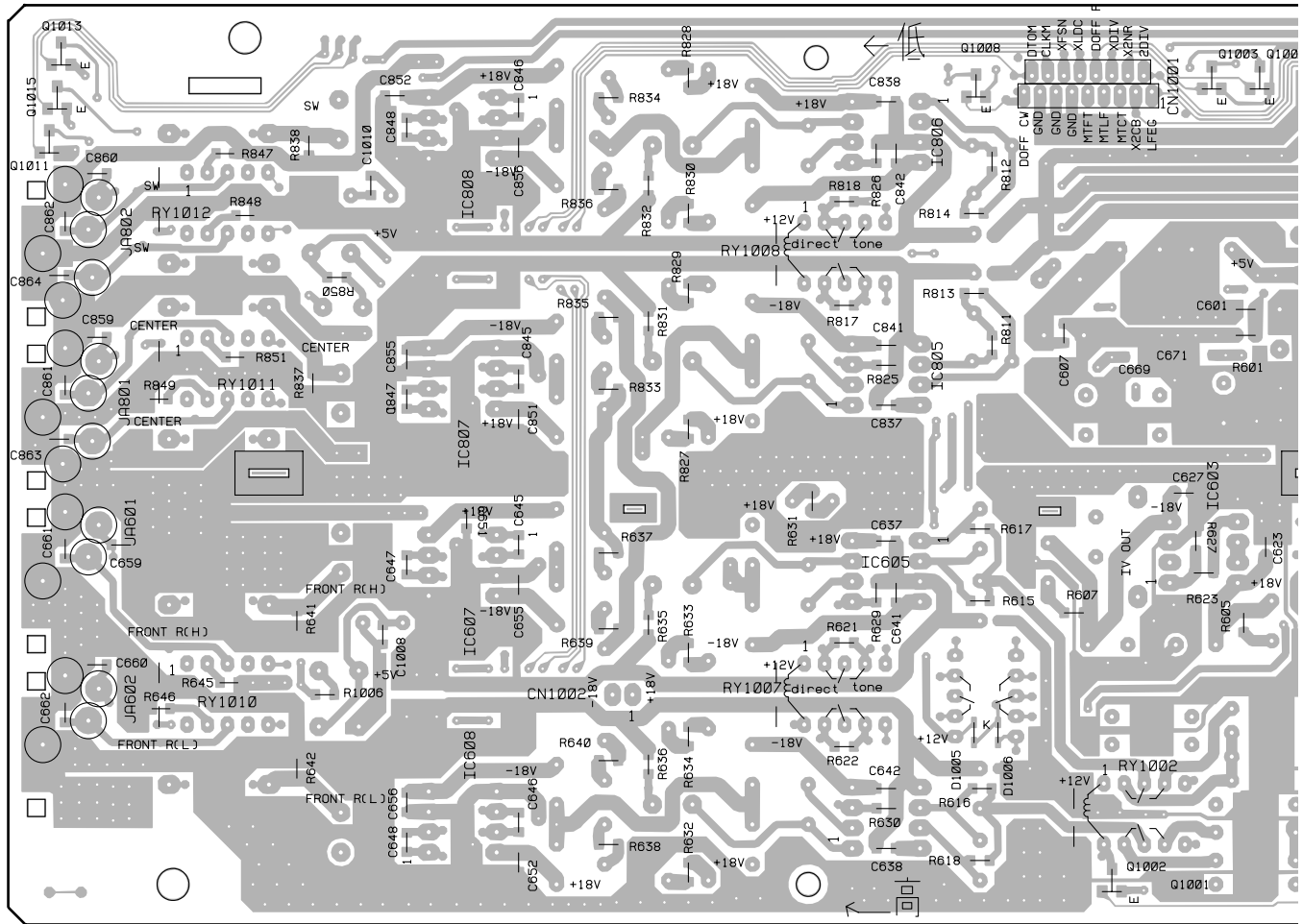

Q1013	Q1008	Q1003	Q1007
Q1015		Q1002	Q100
Q1011			

SIDE B

A

B

C

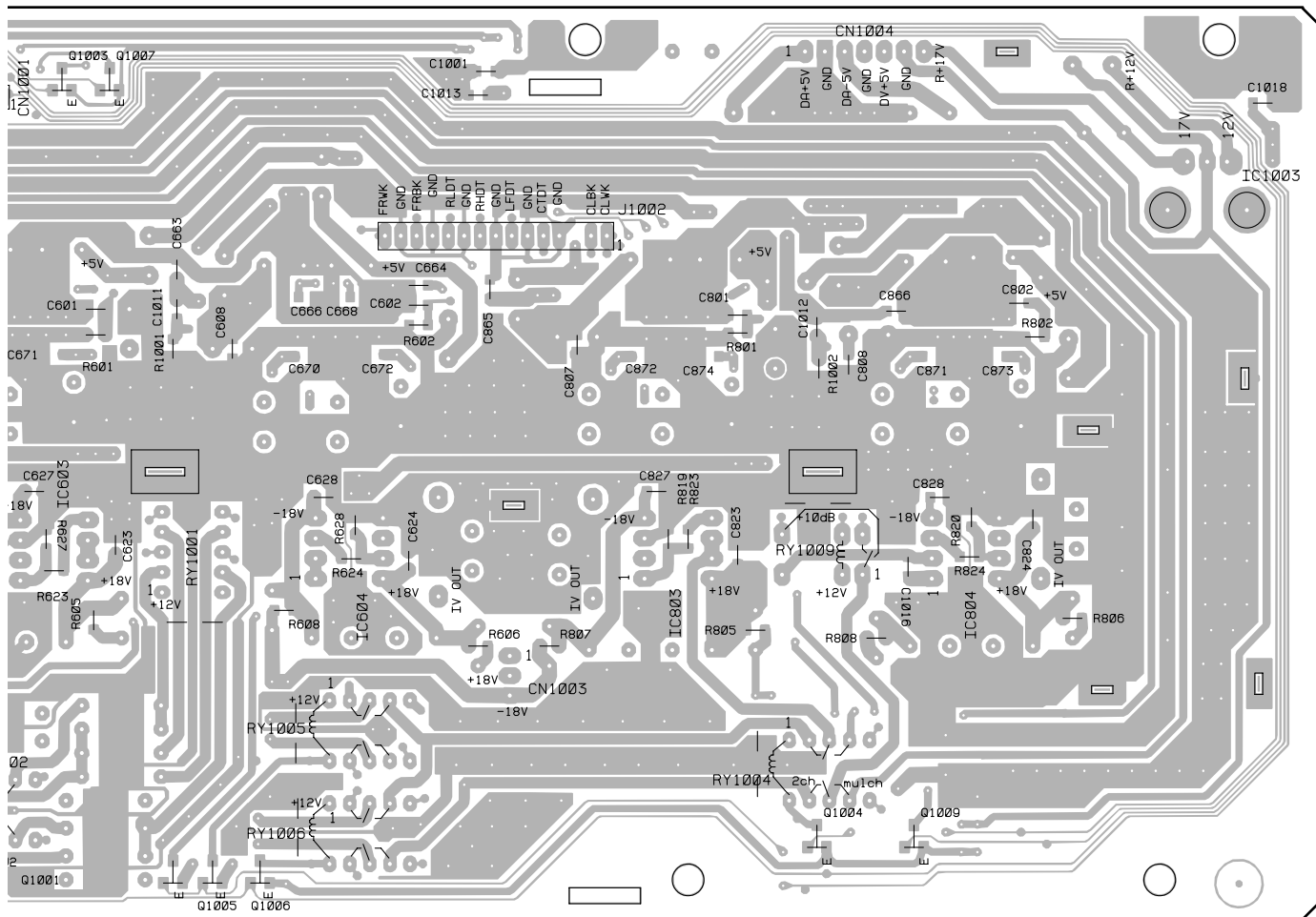

(ANP7291-D)

Y1003 Q1007

Q1001 Q1005 Q1006

Q1004 Q1009

D



4.8 DISPLAY, VOLUME, ENC A, INPUT SW, ENC B ASSYS

J DISPLAY ASSY

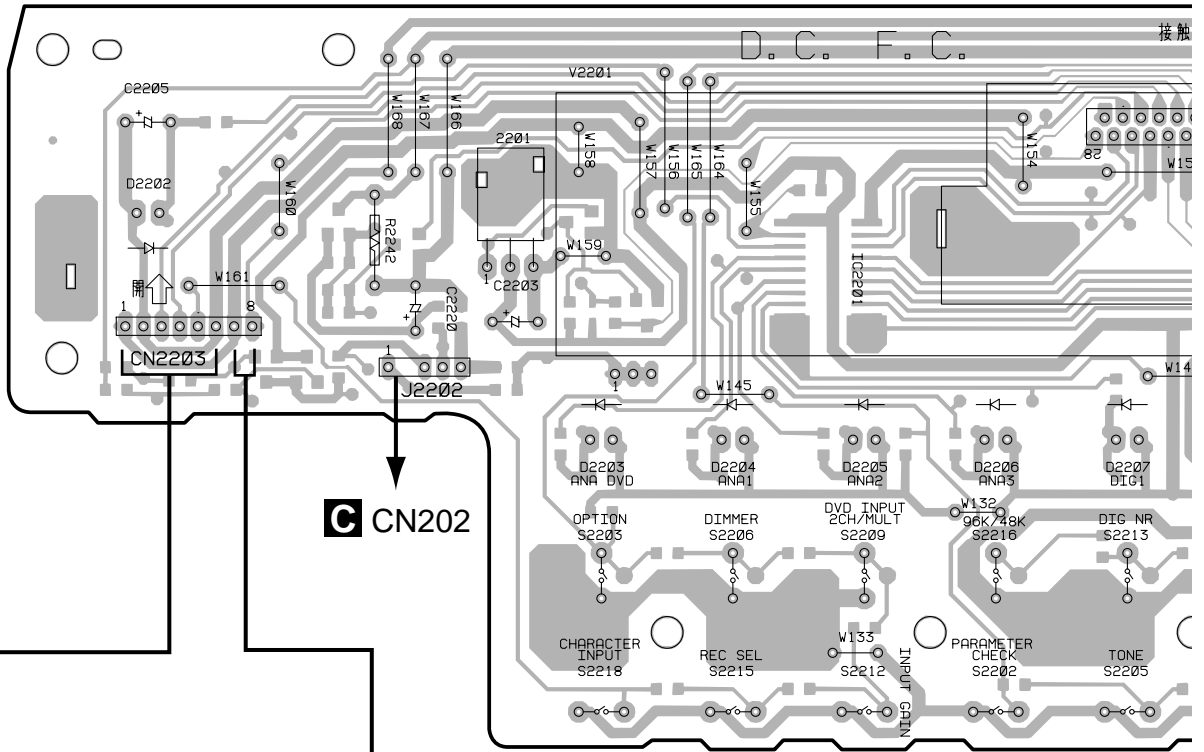

C CN202

L ENC A ASSY

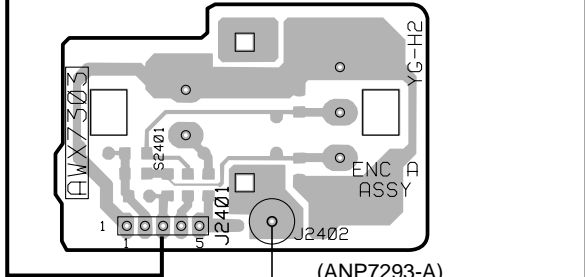

(ANP7293-A)

FRONT PANEL

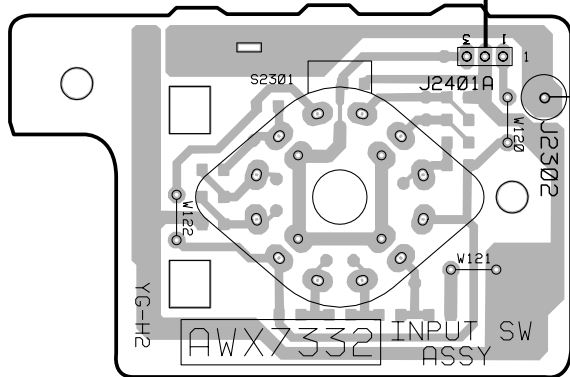

FRONT PANEL

SIDE A

M INPUT SW ASSY (ANP7293-A)

G CN2108

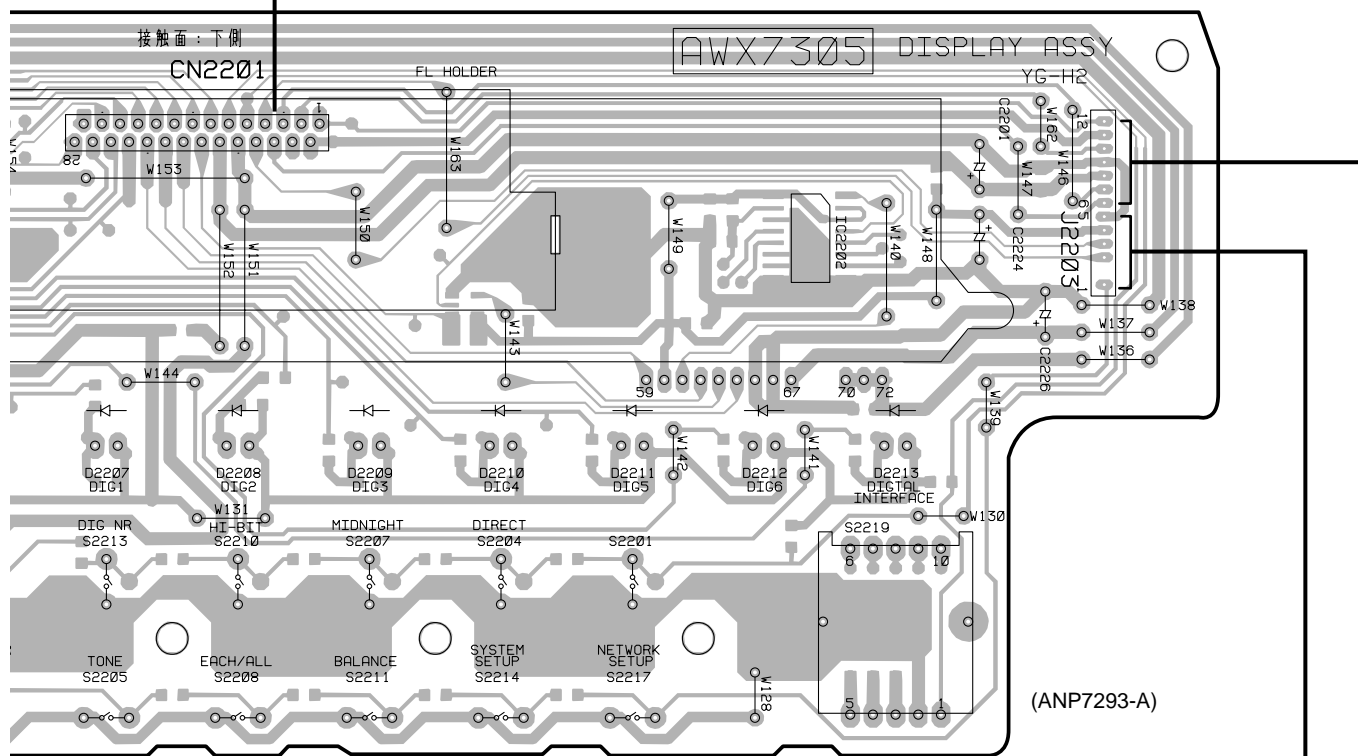

N ENC B ASSY

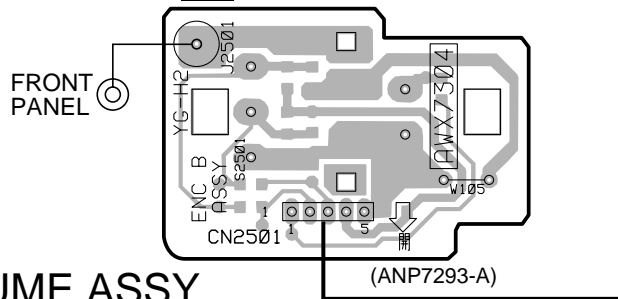

K VOLUME ASSY

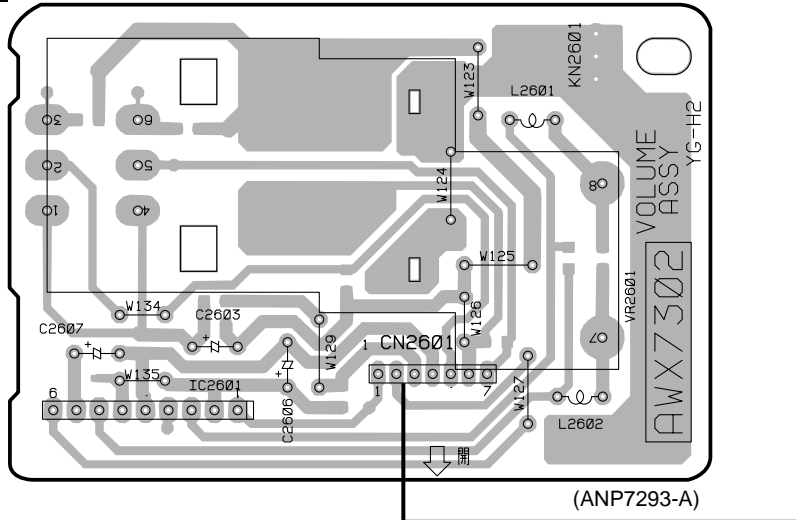

J DISPLAY ASSY IC2202 IC2203

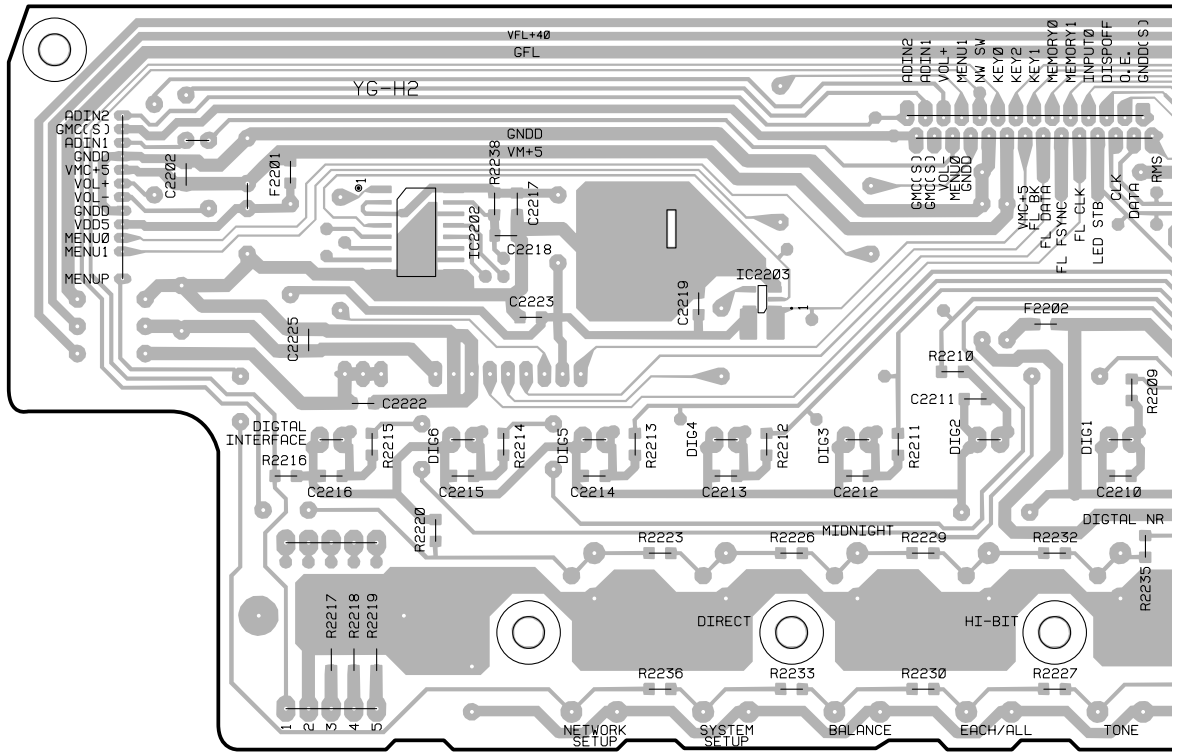

N ENC B ASSY

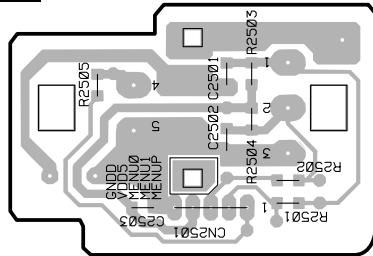

(ANP7293-A)

K VOLUME ASSY

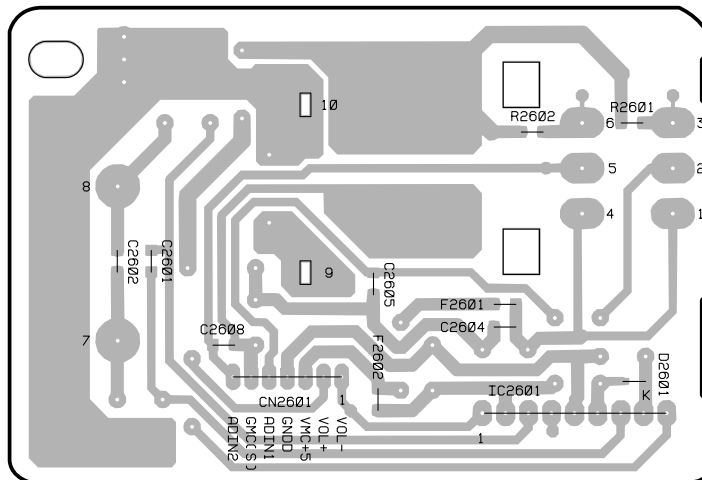

(ANP7293-A)

SIDE B

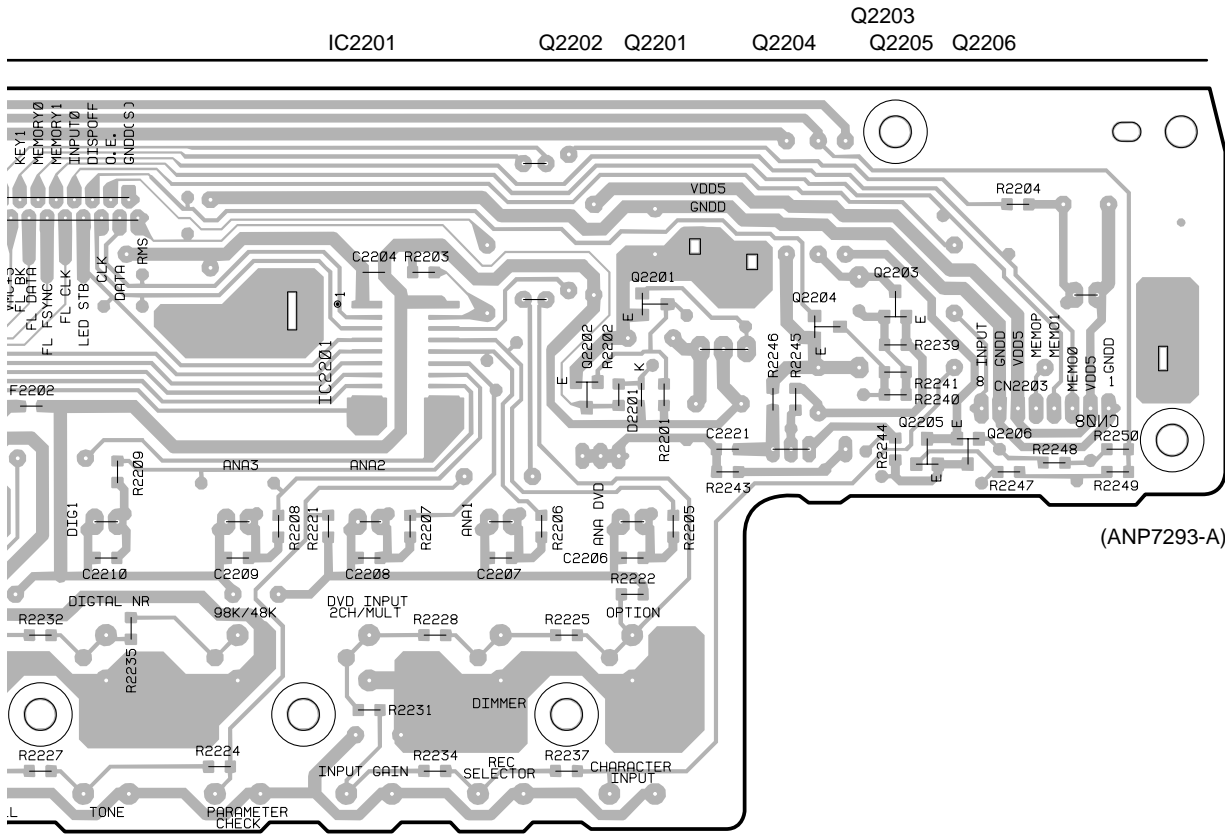

(ANP7293-A)

L ENC A ASSY

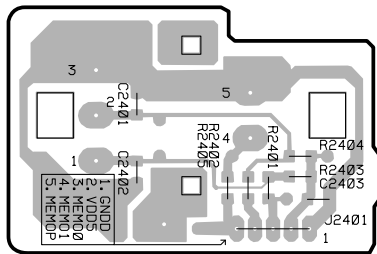

(ANP7293-A)

M INPUT SW ASSY

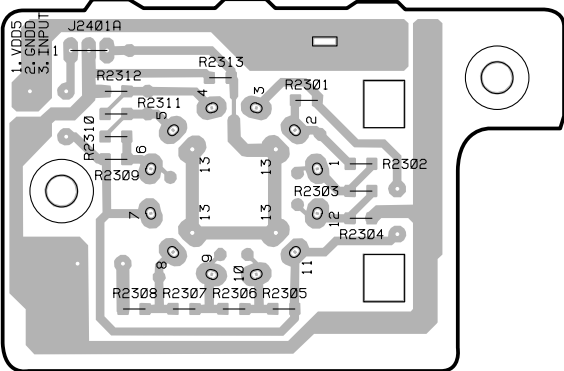

(ANP7293-A)

5. PCB PARTS LIST

NOTES: ●Parts marked by "NSP" are generally unavailable because they are not in our Master Spare Parts List.

●The Δ mark found on some component parts indicates the importance of the safety factor of the part. Therefore, when replacing, be sure to use parts of identical designation.

●When ordering resistors, first convert resistance values into code form as shown in the following examples.

Ex.1 When there are 2 effective digits (any digit apart from 0), such as 560 ohm and 47k ohm (tolerance is shown by J=5%, and K=10%).

560 Ω \rightarrow 56×10^1 \rightarrow 561 RD1/4PU $\boxed{5} \boxed{6} \boxed{1} J$
 47k Ω \rightarrow 47×10^3 \rightarrow 473 RD1/4PU $\boxed{4} \boxed{7} \boxed{3} J$
 0.5 Ω \rightarrow R50 RN2H $\boxed{R} \boxed{5} \boxed{0} K$
 1 Ω \rightarrow 1R0 RS1P $\boxed{1} \boxed{R} \boxed{0} K$

Ex.2 When there are 3 effective digits (such as in high precision metal film resistors).

5.62k Ω \rightarrow 562×10^1 \rightarrow 5621 RN1/4PC $\boxed{5} \boxed{6} \boxed{2} \boxed{1} F$

■ LIST OF WHOLE PCB ASSEMBLIES

Mark	Symbol and Description	Part No.		Remarks
		KU/CA Type	NY Type	
NSP	PSAD ASSY	AWM7490	AWM7490	
	└ DIGITAL I/O ASSY	AWX7533	AWX7533	
	└ SG ASSY	AWX7444	AWX7444	
	└ FRAD ASSY	AWX7532	AWX7532	
	└ CRAD ASSY	AWX7535	AWX7535	
NSP	CONTROL ASSY	AWM7467	AWM7491	
	└ AC ASSY	AWX7298	AWX7536	
	└ PS ASSY	AWX7299	AWX7537	
	└ DISPLAY ASSY	AWX7305	AWX7305	
	└ VOLUME ASSY	AWX7302	AWX7302	
	└ ENC A ASSY	AWX7303	AWX7303	
	└ INPUT SW ASSY	AWX7332	AWX7332	
	└ ENC B ASSY	AWX7304	AWX7304	
NSP	DSP ASSY	AWK7589	AWK7590	
NSP	AUDIO ASSY	AWM7489	AWM7489	
	└ AUDIO A ASSY	AWX7530	AWX7530	
	└ AUDIO B ASSY	AWX7531	AWX7531	

B AC ASSY

AWX7298 and AWX7536 are constructed the same except for the following :

Mark	Symbol and Description	Part No.		Remarks
		AWX7298	AWX7536	
Δ	C101, C102	ACE7014(0.01 μ F/275V)	ACE7034(3300pF/275V)	
Δ	C103 (4700pF/250V)	Not used	ACG7043	
	CAPACITOR COVER	Not used	VEC-063	

C PS ASSY

Although AWX7299 and AWX7537 are different in part number, they consist of the same components.

G DSP ASSY

AWK7589 and AWK7590 are constructed the same except for the following :

Mark	Symbol and Description	Part No.		Remarks
		AWK7589	AWK7590	
	R2142	Not used	RS1/16S473J	
	R2143	RS1/16S473J	Not used	

PCB PARTS LIST FOR C-AX10/KU/CA UNLESS OTHERWISE NOTED

Mark	No.	Description	Part No.	Mark	No.	Description	Part No.
A DIGITAL I/O ASSY				OTHERS			
SEMICONDUCTORS				△	H101,H102	FUSE CLIP	AKR1004
△	IC1407		BA05T	△	CN102	2P VH CONNECTOR	B2P3-VH
	IC1404,IC1405		TC74HC151AF	△	CN103	2P VH CONNECTOR	B2P3-VH-E
	IC1402,IC1406		TC74HCU04AF	△	CN101	SOCKET FOR AC CORD	RKP1751
	IC1401,IC1403		TC7WU04F		KN101	EARTH METAL FITTING	VNF1084
COILS AND FILTERS				C PS ASSY			
	F1401-F1409	CHIP BEAD	DTF1070	SEMICONDUCTORS			
	L1401-L1403		LFEA470J	△	IC201-IC203		AEK7006
	L1406	PULSE TRANS.	PTL1003	△	IC205		PQ3RF23
	L1405	CHOKE COIL	PTL1017	△	Q201		2SC4793
	L1404,L1408	CHIP SOLID INDUCTOR	QTL1015	△	D208,D209		LN6SB60-4000
	L1407,L1409	CHIP BEAD	VTL1099	△	D201		S2VB20F
CAPACITORS					D206		UDZ20B
	C1405,C1412,C1419		CCSQCH220J50		D205		UDZ22B
	C1404,C1411,C1418		CCSQCH470J50		D207		UDZS7.5B
	C1402,C1409,C1416,C1434		CEBA330M25	FILTERS			
	C1401,C1408,C1415,C1433		CKSQYB103K50		F201,F203-F206	CHIP BEAD	DTF1070
	C1406,C1413,C1420,C1423,C1425		CKSQYB104K25	CAPACITORS			
	C1427,C1429-C1431,C1436,C1438		CKSQYB104K25		C209,C215 (1μF/100V)		ACH1237
	C1445		CKSQYB104K25		C205		CEBA471M63
	C1443		CKSQYB334K16		C210,C211,C217,C218		CKSQYB103K50
	C1432 (0.1μF)		OCG1014		C204		CKSQYB104K25
	C1444 (1000μF/16V)		PCH1122		C214		CKSQYB334K16
	C1407,C1414,C1421,C1422,C1424		PCH1128		C201-C203		CQMA103K2E
	(220μF/25V)		PCH1128		C206-C208,C216 (47μF/50V)		PCH1124
	C1426,C1428,C1437,C1439		PCH1128		C212 (10000μF/16V)		VCH1054
	(220μF/25V)		PCH1141	RESISTORS			
	C1440 (1000μF/16V)		PCH1141		R201		RS1LMF222J
RESISTORS					Other Resistors		RS1/10S□□□J
	All Resistors		RS1/10S□□□J	OTHERS			
OTHERS					J201	CONNECTOR ASSY 6P	ADX7263
	JA1401-JA1403,JA1407		AKB7102		H201-H204	FUSE CLIP	AKR1004
	1P PIN JACK		TORX176(HS)		202,203	HEAT SINK B	ANH1021
	JA1404-JA1406		TOTX176(HS)		201	HEAT SINK	ANH7121
	OPTICAL RECEIVER MODULE		VKN1274		CN202	KR CONNECTOR	B4B-PH-K-S
	JA1408		VKN1274		CN201	9P TOP POST	B9P-VH
	OPTICAL SEND MODULE		VKN1274			PCB BINDER	VEF1040
	CN1401	14P FFC CONNECTOR	VKN1274		KN201	EARTH METAL FITTING	VNF1084
B AC ASSY				D SG ASSY			
FILTER				OTHERS			
△	F101	EMC FILTER	ATF7023		3001	SCREW TERMINAL	VNE1948
SWITCH				OTHERS			
△	S101		PSA1004	OTHERS			
CAPACITORS				OTHERS			
△	C101,C102 (0.01μF/275V)		ACE7014	OTHERS			

C-AX10

Mark	No.	Description	Part No.
E FRAD ASSY			
SEMICONDUCTORS			
△	IC304,IC411-IC413	AEK7006	
△	IC405	AEK7010	
△	IC403	AEK7016	
△	IC408	AEK7023	
	IC1105	AK5393VS	
△	IC306	BA05T	
△	IC401,IC402,IC407,IC409,IC410	ICP-N25	
△	IC406	LM317T	
△	IC1101,IC1102,IC1106	M5220P	
△	IC404	NJM7812FA	
	IC1103,IC1104	OP275GP	
△	IC302	PQ05RR12	
	IC1204	TC74VHC157F	
	IC1203	TC74VHC244F	
	IC1202	TC74VHC74F	
	IC1201	TC74VHCU04F	
△	Q404,Q406,Q420,Q422	2SA1037K	
△	Q402,Q418	2SB1375	
△	Q403,Q405,Q408,Q409,Q419	2SC2412K	
△	Q421	2SC2412K	
△	Q416	2SC4793	
△	Q401,Q407,Q417	2SD2012	
△	Q1101-Q1109,Q1201,Q1301,Q1302	DTC124EK	
△	D407,D409	11DF2	
△	D408,D410	11DF2FD	
	D1101-D1118,D1301-D1304	1SS355	
△	D402,D404,D412,D414	31DF2-FC5	
△	D401,D403,D411,D413	31DF2-FC6	
	D1119,D1120,D301	DAN202K	
	D1121,D1122	DAP202K	
	D415,D419,D420	HZS3CLL	
	D405,D406	HZS5CLL	
	D418	UDZS5.6B	
COILS AND FILTERS			
	F1101-F1103,F1201,F1202	DTF1070	
	CHIP BEAD		
	L1104-L1111,L1202,L1204	DTL1019	
	CHIP BEAD FILTER		
	L1301-L1304 CHIP BEAD FILTER	DTL1019	
	L404 FERRITE BEAD	PTH1015	
	L1101-L1103,L1201,L1203,L1205	RTF1167	
	NOISE FILTER		
	L301,L401-L403 NOISE FILTER	RTF1167	
RELAYS			
	RY1101-RY1109,RY1301,RY1302	VSR1008	
CAPACITORS			
	C1123,C1124,C1171,C1172 (470pF)	ACE7018	
	C401,C402,C415,C418,C419	ACH1237	
	(1μF/100V)		
	C403,C404 (3300μF/35V)	ACH7107	
	C420,C421 (4700μF/16V)	ACH7108	
	C301 (12000μF/16V)	ACH7127	
	C411,C412 (10μF/50V)	ACH7133	
	C1175,C1203	CCSQCH100D50	
	C1155,C1156,C1161,C1162	CCSQCH101J50	
	C409,C410,C427,C443,C444	CCSQCH121J50	

Mark	No.	Description	Part No.
	C1202		CCSQCH5R0C50
	C1152		CEGA100M50
	C1125-C1128		CEGA220M50
	C1119-C1122,C1159,C1160		CEGANP470M16
	C303,C430,C435,C436		CEHAZL470M25
	C413,C414,C438		CEHAZL561M35
	C1117,C1118,C428,C445,C446		CENA100M50
	C305,C405,C406,C425		CENA1R0M50
	C439,C440		CENA1R0M50
	C1307-C1310,C437		CENA470M25
	C1210		CKSQYB102K50
	C1211,C1212,C451-C454		CKSQYB103K50
	C1141,C1142,C1145,C1146,C1151		CKSQYB104K25
	C1153,C1154,C1173,C1174		CKSQYB104K25
	C1204-C1206,C1208,C422		CKSQYB104K25
	C1129,C1130		CKSQYB222K50
	C1143,C1144		CKSQYB224K16
	C302,C306		CKSQYB334K16
	C1131,C1132,C1135,C1136		CKSQYB473K50
	C1163-C1166,C1169,C1170		CKSQYB473K50
	C1150 (0.1μF)		OCG1014
	C304,C307,C417,C424,C429		PCH1122
	(1000μF/16V)		
	C447,C448 (1000μF/16V)		PCH1122
	C416 (3300μF/25V)		PCH1125
	C407,C408,C426,C441,C442		PCH1126
	(100μF/50V)		
	C1133,C1134,C1137,C1138		PCH1128
	(220μF/25V)		
	C1167,C1168,C1209,C423		PCH1128
	(220μF/25V)		
	C1139,C1140,C1201 (47μF/10V)		RCH1139
	C1147-C1149 (10μF/6.3V)		VCH1155
RESISTORS			
	R1207		RD1/4PU470J
	R401,R402		RDR1/4PM100J
	R1117-R1120		RDR1/4PM104J
	R1121,R1122,R1133,R1134		RDR1/4PM1101F
	R1127,R1128,R1131,R1132		RDR1/4PM1801F
	R1123,R1124		RDR1/4PM1802F
	R1137-R1140		RDR1/4PM3901F
	R1141-R1144		RDR1/4PM51R0F
	R1129,R1130		RDR1/4PM5601F
	R1109,R1110,R1113-R1116		RN1/10SE1001D
	R1163,R1164		RN1/10SE1001D
	R1149-R1152		RN1/10SE1002D
	R1159-R1162,R1305-R1312		RN1/10SE1003D
	R433-R437		RN1/10SE1003D
	R1135,R1136		RN1/10SE1201D
	R1165,R1166		RN1/10SE1502D
	R1167,R1168		RN1/10SE1601D
	R405,R406		RN1/10SE1802D
	R411		RN1/10SE2400D
	R1111,R1112		RN1/10SE2702D
	R414,R429,R430		RN1/10SE3001D
	R410		RN1/10SE3900D
	R1145-R1148		RN1/10SE3901D
	R407,R408		RN1/10SE7501D
	R415,R431,R432		RN1/10SE9101D
△	R1125,R1126,R1153-R1156		RS1/10S510J
	R403,R404		RS1LMF222J
	Other Resistors		RS1/10S□□□J

Mark	No.	Description	Part No.
OTHERS			
J405		CONNECTOR ASSY 1P	ADX7265
J401		CONNECTOR ASSY 1P	ADX7266
J1201		CONNECTOR ASSY 12P	ADX7267
J403		CONNECTOR ASSY 8P	ADX7269
J1203		CONNECTOR ASSY 4P	ADX7318
J301		CONNECTOR ASSY 12P	ADX7327
JA1101,JA1104		2P PIN JACK	AKB7104
JA1102,JA1103,JA1301		4P PIN JACK	AKB7105
402		HEAT SINK	ANH7100
CN1202		KR CONNECTOR	B13B-PH-K-S
CN406		2P VH CONNECTOR	B2P-VH
CN407		3P VH CONNECTOR	B3P-VH
CN405		3P VH CONNECTOR	B3P-VH-BL
X1201		CRYSTAL RESONATOR (24MHz)	RSS1047
CN1201		FFC CONNECTOR PCB BINDER	SLW16S-1C7 VEF1040

F CRAD ASSY SEMICONDUCTORS

IC2704,IC2804	AK5393VS
IC2703,IC2803	M5220P
IC2701,IC2702,IC2801,IC2802	NJM5532DD
Q2701,Q2702,Q2801,Q2802	DTC124EK
D2701-D2704,D2801-D2804	1SS355
D2705,D2706,D2805,D2806	DAN202K
D2707,D2708,D2807,D2808	DAP202K

COILS

L2701,L2702,L2801,L2802,L2901	RTF1167
NOISE FILTER	

RELAYS

RY2701,RY2702,RY2801,RY2802	VSR1008
-----------------------------	---------

CAPACITORS

C2737,C2738,C2837,C2838	CCSQCH101J50
C2705,C2706,C2805,C2806	CCSQCH471J50
C2730,C2830	CEGA100M50
C2707-C2710,C2807-C2810	CENA220M25
C2703,C2704,C2803,C2804	CENA470M25
C2702,C2802	CKSQYB102K50
C2719,C2720,C2723,C2724,C2729	CKSQYB104K25
C2731,C2732,C2819,C2820	CKSQYB104K25
C2823,C2824,C2829,C2831,C2832	CKSQYB104K25
C2711,C2712,C2811,C2812	CKSQYB222K50
C2721,C2722,C2821,C2822	CKSQYB224K16
C2713,C2714,C2733-C2736	CKSQYB473K50
C2813,C2814,C2833-C2836	CKSQYB473K50
C2728,C2828 (0.1μF)	OCG1014
C2715,C2716,C2815,C2816,C2901	PCH1128
(220μF/25V)	
C2717,C2718,C2817,C2818	RCH1139
(47μF/10V)	
C2725-C2727,C2825-C2827	VCH1155
(10μF/6.3V)	

Mark	No.	Description	Part No.
RESISTORS			
		R2725-R2728,R2825-R2828	RN1/10SC51R0D
		R2733-R2736,R2833-R2836	RN1/10SE1002D
		R2709,R2710,R2717,R2718	RN1/10SE1101D
		R2809,R2810,R2817,R2818	RN1/10SE1101D
		R2719,R2720,R2819,R2820	RN1/10SE1201D
		R2711,R2712,R2715,R2716	RN1/10SE1801D
		R2811,R2812,R2815,R2816	RN1/10SE1801D
		R2705,R2706,R2805,R2806	RN1/10SE1802D
		R2721-R2724,R2729-R2732	RN1/10SE3901D
		R2821-R2824,R2829-R2832	RN1/10SE3901D
		R2713,R2714,R2813,R2814	RN1/10SE5601D
△		R2737,R2738,R2837,R2838	RS1/10S510J
		Other Resistors	RS1/10S□□□□

OTHERS

J2901	CONNECTOR ASSY 7P	ADX7268
J2903	CONNECTOR ASSY13P PCB BINDER	ADX7270 VEF1040

G DSP ASSY SEMICONDUCTORS

IC2106	AT24C16N-10SI2.5
IC2101,IC2107,IC2108,IC2118	BU4094BCFV
IC1602,IC1603	CS8414-CS
IC1902,IC2002	DF1704E
IC1610,IC1901,IC2001	PD0236AM
IC1502	PDK038A
IC2105	PEA003A
IC2110	PEA004A
△ IC1511,IC1513,IC1607	PQ3DZ13
IC1703,IC1803	SM5847AF
IC1504	TC55V1664BFT-12
IC1503	TC55V8128BJ-12
IC2111,IC2112	TC74HC125AF
IC1609	TC74HCT08AF
IC1507	TC74HCT244AF
IC2116	TC74HCU04AF
IC1612,IC2117	TC74VHC00FT
IC1624,IC1625	TC74VHC08FT
IC1614	TC74VHC153FT
IC1510,IC1601,IC1608,IC1632,IC1704	TC74VHC157FT
IC1804,IC1903,IC2003	TC74VHC157FT
IC1620	TC74VHC163FT
IC1506	TC74VHC244FT
IC1505	TC74VHC257FT
IC2113	TC74VHC32FT
IC1606,IC1623	TC74VHC4040FT
IC1512,IC1622	TC74VHC74FT
IC1509,IC1619	TC74VHCU04FT
IC2104	TC7S66FU
IC1616	TC7SET08F
IC2103,IC2114	TC7W126FU
IC1508,IC1615,IC2115	TC7WH04FU
IC1904,IC2004	TC7WH08FU
IC1611,IC1621	TC7WH74FU
IC1605	TC7WT74FU

C-AX10

Mark	No.	Description	Part No.
	IC1618		TC9246F
	IC1501,IC1613,IC1701,IC1702		XCD56362PV100
	IC1801,IC1802		XCD56362PV100
	Q2101		2SA1037K
	D2106		1SS254
	D1601,D1602,D2101,D2102		1SS355
	D2104,D2105		1SS355
	D1701,D1702,D1801,D1802		DA204K
	D1901,D1902,D2001,D2002		DA204K
	D2103		DAN202K

COILS AND FILTERS

F1501-F1505,F1507,F1508	DTF1070
CHIP BEAD	
F1601-F1612,F1614,F1701-F1703	DTF1070
CHIP BEAD	
F1801-F1803,F1901,F1902,F2001	DTF1070
CHIP BEAD	
F2101-F2105,F2108-F2110	DTF1070
CHIP BEAD	
L1603 CHIP BEAD FILTER	DTL1019
L1601,L1602	QTL1015
CHIP SOLID INDUCTOR	
L1701-L1704,L1801-L1804	VTL1083
CHIP BEAD	
L1604 CHIP BEAD	VTL1103
L1705,L1706,L1805,L1806	VTL1105
CHIP BEAD	

CAPACITORS

C1501,C1502,C1602,C1612,C1628	ACH7109
(56μF/10V)	
C1668,C1670,C1681,C1757,C1760	ACH7109
(56μF/10V)	
C1857,C1860,C1901,C1905,C2001	ACH7109
(56μF/10V)	
C2128 (56μF/10V)	ACH7109
C1663,C1685,C1686,C1690,C1770	ACH7126
(330μF/16V)	
C1870 (330μF/16V)	ACH7126
C1766-C1769,C1866-C1869	CCSRCH100D50
C1504,C1514,C1518,C1525,C1531	CCSRCH101J50
C1544,C1548,C1635,C1641,C1645	CCSRCH101J50
C1651,C1657,C1705,C1712,C1715	CCSRCH101J50
C1721,C1727,C1732,C1739,C1742	CCSRCH101J50
C1748,C1754,C1805,C1812,C1815	CCSRCH101J50
C1821,C1827,C1832,C1839,C1842	CCSRCH101J50
C1848,C1854	CCSRCH101J50
C1508,C1509,C1664	CCSRCH150J50
C2124,C2143,C2145,C2146,C2148	CCSRCH330J50
C2152-C2154	CCSRCH330J50
C1701,C1702,C1801,C1802,C1907	CEV101M16
C2120-C2122,C2149	CEV101M16
C1511,C1534,C1536,C1539,C1542	CEV470M6R3
C1546,C1553,C1555,C1606,C1615	CEV470M6R3
C1619,C1622,C1627,C1629,C1631	CEV470M6R3
C1660,C1683,C1684,C2102,C2104	CEV470M6R3
C2108,C2111,C2117,C2132,C2137	CEV470M6R3
C1608,C1617	CFHS473J16
C2160	CKSQYB104K25
C1552,C1554,C1624	CKSQYB334K16

Mark	No.	Description	Part No.
	C1516,C1640,C1665,C1711,C1738		CKSQYB474K16
	C1811,C1838		CKSQYB474K16
	C1503,C1505-C1507,C1513,C1517		CKSRYB103K50
	C1519-C1524,C1526-C1530		CKSRYB103K50
	C1532,C1533,C1540,C1543,C1547		CKSRYB103K50
	C1604,C1605,C1609,C1610		CKSRYB103K50
	C1633,C1634,C1636-C1638		CKSRYB103K50
	C1643,C1644,C1646-C1650		CKSRYB103K50
	C1652-C1656,C1658,C1659,C1666		CKSRYB103K50
	C1672,C1673,C1703,C1704		CKSRYB103K50
	C1706,C1707,C1709,C1713,C1714		CKSRYB103K50
	C1716-C1720,C1722-C1726		CKSRYB103K50
	C1728-C1731,C1733,C1734,C1736		CKSRYB103K50
	C1740,C1741,C1743-C1747		CKSRYB103K50
	C1749-C1753,C1755,C1756		CKSRYB103K50
	C1803,C1804,C1806,C1807,C1809		CKSRYB103K50
	C1813,C1814,C1816-C1820		CKSRYB103K50
	C1822-C1826,C1828-C1831		CKSRYB103K50
	C1833,C1834,C1836,C1840,C1841		CKSRYB103K50
	C1843-C1847,C1849-C1853		CKSRYB103K50
	C1855,C1856,C2125-C2127		CKSRYB103K50
	C2130,C2131,C2139		CKSRYB103K50
	C1515,C1642,C1710,C1737,C1810		CKSRYB682K50
	C1837		CKSRYB682K50
	C1510,C1535,C1537,C1538		CKSRYF104Z25
	C1549-C1551,C1601,C1603,C1607		CKSRYF104Z25
	C1611,C1613,C1614,C1616,C1618		CKSRYF104Z25
	C1620,C1621,C1623,C1625,C1626		CKSRYF104Z25
	C1630,C1632,C1661,C1662,C1669		CKSRYF104Z25
	C1671,C1674-C1680,C1687		CKSRYF104Z25
	C1692,C1693,C1758,C1759		CKSRYF104Z25
	C1761-C1765,C1858,C1859		CKSRYF104Z25
	C1861-C1865,C1902-C1904,C1906		CKSRYF104Z25
	C2002-C2005,C2101,C2103		CKSRYF104Z25
	C2105-C2107,C2109,C2110,C2112		CKSRYF104Z25
	C2114-C2116,C2118,C2119,C2123		CKSRYF104Z25
	C2129,C2133-C2136,C2138		CKSRYF104Z25
	C2140-C2142,C2144,C2147		CKSRYF104Z25
	C2150,C2151,C2156,C2158,C2159		CKSRYF104Z25
	C2161-C2165		CKSRYF104Z25

RESISTORS

R2132,R2152,R2156	RA4C101J
R2117,R2145	RA4C103J
R2118,R2146	RA4C220J
R2101,R2102,R2158,R2159	RA4C473J
R1673,R1675,R1677-R1684,R1709	RS1/10S0R0J
R1723-R1727,R1729,R1731,R1733	RS1/10S0R0J
R1809,R1823-R1827,R1829,R1831	RS1/10S0R0J
R1833,R1917,R1918,R1920	RS1/10S0R0J
R2017,R2018,R2020,R2163,R2165	RS1/10S0R0J
R2167,R2169,R2170,R2189	RS1/10S0R0J
R1722,R1728,R1730,R1732,R1734	RS1/10S101J
R1822,R1828,R1830,R1832,R1834	RS1/10S101J
R2002	RS1/10S470J
R1550,R1551	RS1/10S473J
Other Resistors	RS1/16S□□□J

Mark	No.	Description	Part No.
OTHERS			
	IC9001,IC9002	IC SOCKET	IC160-0324-230
	J2102	CONNECTOR ASSY 3P	ADX7348
	X1501	CRYSTAL RESONATOR (20MHz)	ASS7023
	X2101,X2102	CERAMIC RESONATOR (7.7MHz)	ASS7026
	CN1602	CONNECTOR 12P	B12B-ZR-SM3
	CN2104	PH CONNECTOR	B2B-PH-SM3
	CN2109	PH CONNECTOR	B3B-PH-SM3
	CN2107	PH CONNECTOR	B8B-PH-SM3
	J2101	STEREO MINI JACK	QKN1004
	JA2101,JA2102	REMOTE CONTROL JACK	RKN1004
	CN2105,CN2106	7P FFC CONNECTOR	VKN1299
	CN1601	14P FFC CONNECTOR	VKN1418
	CN2102	15P FFC CONNECTOR	VKN1419
	CN2101	16P FFC CONNECTOR	VKN1420
	CN2103	17P FFC CONNECTOR	VKN1421
	CN2108	28P FFC CONNECTOR	VKN1432
	CN1703	14P CONNECTOR	VKN1549
	CN1803	15P CONNECTOR	VKN1550
	2105,2106	SCREW TERMINAL	VNE1948
	KN2101-KN2104	EARTH METAL FITTING	VNF1109

H AUDIO A ASSY SEMICONDUCTORS

	IC901,IC902	AD7564BR
	IC503-IC506,IC703-IC706	NJM2114D-D
△	IC903	NJM7812FA
	IC507,IC508,IC707,IC708	OP275GP
	IC501,IC502,IC701,IC702	PCM1704U-J
	Q901-Q908,Q910,Q912	DTC124EK
	D901-D920	1SS355

COILS AND FILTER

F901	CHIP BEAD	DTF1070
L501-L504,L701-L704	NOISE FILTER	RTF1167
L901,L902	NOISE FILTER	RTF1167

RELAYS

RY901-RY910	VSR1008
-------------	---------

CAPACITORS

C519,C520,C719,C720 (100pF)	ACE7015
C531-C534,C733,C734 (150pF)	ACE7016
C731,C732 (330pF)	ACE7017
C529,C530 (1800pF)	ACE7019
C729,C730 (3300pF)	ACE7020
C543,C544,C557,C558 (100μF/50V)	ACH7122
C743,C744,C757,C758 (100μF/50V)	ACH7122
C545-C548,C745-C748	CCSQCH100D50
C513,C514,C713,C714	CEGA101M16
C511,C512,C711,C712,C907	CEHAZA101M25
C909	CEHAZA101M25
C905	CENA100M50
C505,C506,C509,C510	CENA101M25
C705,C706,C709,C710	CENA101M25
C563,C564,C566,C568-C572	CKSQYB103K50

Mark	No.	Description	Part No.
	C765,C766,C771-C774		CKSQYB103K50
	C507,C508,C559,C560		CKSQYB104K25
	C707,C708,C759,C760		CKSQYB104K25
	C916,C917		CKSQYB104K25
	C501,C502,C523,C524		CKSQYB473K50
	C527,C528,C537,C538		CKSQYB473K50
	C541,C542,C551,C552		CKSQYB473K50
	C555,C556,C701,C702		CKSQYB473K50
	C723,C724,C727,C728		CKSQYB473K50
	C737,C738,C741,C742		CKSQYB473K50
	C751,C752,C755,C756,C908		CKSQYB473K50
	C910-C912		CKSQYB473K50
	C565,C567,C767-C770		CKSRYB103K50
	C503,C504,C703,C704,C902	(1000μF/16V)	PCH1122
	C906,C914,C915 (1000μF/16V)		PCH1122
	C521,C522,C525,C526 (100μF/25V)		PCH1126
	C721,C722,C725,C726 (100μF/25V)		PCH1126
	C535,C536,C539,C540 (220μF/25V)		PCH1128
	C549,C550,C553,C554 (220μF/25V)		PCH1128
	C735,C736,C739,C740 (220μF/25V)		PCH1128
	C749,C750,C753,C754 (220μF/25V)		PCH1128
	C903,C904 (220μF/25V)		PCH1128
	C515-C518,C715-C718 (47μF/10V)		RCH1139

RESISTORS

	R503,R504,R703,R704	RDM1/2P3901F
	R543,R544,R739,R740	RDM1/2P51R0F
	R561,R562	RDR1/4PM1201F
	R560,R563,R753,R754	RDR1/4PM2401F
	R559,R564,R751,R752	RDR1/4PM4701F
	R521-R524,R545,R546	RN1/10SE1001D
	R717,R718,R723,R724	RN1/10SE1001D
	R745,R746	RN1/10SE1001D
	R515,R516,R709-R712	RN1/10SE1201D
	R529,R530,R725,R726	RN1/10SE1501D
	R525,R526,R721,R722	RN1/10SE1801D
	R541,R542,R737,R738	RN1/10SE2702D
	R517-R520,R713-R716,R903	RN1/10SE3601D
△	R505-R508,R531-R534	RS1/10S510J
△	R537-R540,R705-R708	RS1/10S510J
△	R727-R730,R733-R736	RS1/10S510J
	Other Resistors	RS1/10S□□□J

OTHERS

J902	CONNECTOR ASSY 14P	ADX7271
JA501,JA502,JA701,JA702	1P PIN JACK	AKB7102
902	HEAT SINK	ANH7100
CN901	FFC CONNECTOR	SLW15S-1C7
901	PCB BINDER	VEF1040
	BUS LINE B	VNF1113

I AUDIO B ASSY SEMICONDUCTORS

	IC1001,IC1002	AD7564BR
	IC603-IC606,IC803-IC806	NJM2114D-D
△	IC1003	NJM7812FA
	IC607,IC608,IC807,IC808	OP275GP
	IC601,IC602,IC801,IC802	PCM1704U-J

C-AX10

Mark	No.	Description	Part No.
	Q1001-Q1009,Q1011,Q1013,Q1015 D1001-D1024		DTC124EK 1SS355

COILS AND FILTER

F1001	CHIP BEAD	DTF1070
L1001,L1002,L601-L604	NOISE FILTER	RTF1167
L801-L804	NOISE FILTER	RTF1167

RELAYS

RY1009	VSR1006
RY1001-RY1008,RY1010-RY1012	VSR1008

CAPACITORS

C619,C620,C819,C820 (100pF)	ACE7015
C631-C634,C833,C834 (150pF)	ACE7016
C831,C832 (330pF)	ACE7017
C629,C630 (1800pF)	ACE7019
C829,C830 (3300pF)	ACE7020
C643,C644,C657,C658 (100μF/50V)	ACH7122
C843,C844,C857,C858 (100μF/50V)	ACH7122
C1016,C645-C648,C845-C848	CCSQCH100D50
C613,C614,C813,C814	CEGA101M16
C1007,C1009,C611,C612	CEHAZA101M25
C811,C812	CEHAZA101M25
C1005	CENA100M50
C605,C606,C609,C610	CENA101M25
C805,C806,C809,C810	CENA101M25
C663,C664,C666,C668-C672	CKSQYB103K50
C865,C866,C871-C874	CKSQYB103K50
C1017,C1018,C607,C608	CKSQYB104K25
C659,C660,C807,C808	CKSQYB104K25
C859,C860	CKSQYB104K25
C1008,C1010-C1012,C601,C602	CKSQYB473K50
C623,C624,C627,C628	CKSQYB473K50
C637,C638,C641,C642	CKSQYB473K50
C651,C652,C655,C656	CKSQYB473K50
C801,C802,C823,C824	CKSQYB473K50
C827,C828,C837,C838	CKSQYB473K50
C841,C842,C851,C852	CKSQYB473K50
C855,C856	CKSQYB473K50
C665,C667,C867-C870	CKSRYB103K50
C1002,C1006,C1014,C1015 (1000μF/16V)	PCH1122
C603,C604,C803,C804 (1000μF/16V)	PCH1122
C621,C622,C625,C626 (100μF/25V)	PCH1126
C821,C822,C825,C826 (100μF/25V)	PCH1126
C1003,C1004,C635,C636 (220μF/25V)	PCH1128
C639,C640,C649,C650 (220μF/25V)	PCH1128
C653,C654,C835,C836 (220μF/25V)	PCH1128
C839,C840,C849,C850 (220μF/25V)	PCH1128
C853,C854 (220μF/25V)	PCH1128
C615-C618,C815-C818 (47μF/10V)	RCH1139

RESISTORS

R603,R604,R803,R804	RDM1/2P3901F
R643,R644,R839-R842	RDM1/2P51R0F
R661,R664	RDR1/4PM1201F
R662,R663,R855,R856	RDR1/4PM2401F
R659,R660,R853,R854	RDR1/4PM4701F

Mark	No.	Description	Part No.
	R621-R624,R645,R646 R817,R818,R823,R824 R847-R849,R851 R1004 R615,R616,R809-R812		RN1/10SE1001D RN1/10SE1001D RN1/10SE1001D RN1/10SE1102D RN1/10SE1201D
	R629,R630,R825,R826 R625,R626,R821,R822 R641,R642,R837,R838 R1003,R617-R620,R813-R816 R1005		RN1/10SE1501D RN1/10SE1801D RN1/10SE2702D RN1/10SE3601D RN1/10SE5101D
△	R605-R608,R631-R634		RS1/10S510J
△	R637-R640,R805-R808		RS1/10S510J
△	R827-R830,R833-R836 Other Resistors		RS1/10S510J RS1/10S□□□J

OTHERS

J1002	CONNECTOR ASSY 14P	ADX7273
JA601,JA602	1P PIN JACK	AKB7102
JA801,JA802	2P PIN JACK	AKB7104
1002	HEAT SINK	ANH7100
CN1002	2P TOP POST	B2B-EH
CN1003	3P TOP POST	B3B-EH
CN1001	FFC CONNECTOR PCB BINDER	SLW17S-1C7 VEF1040
1001	BUS LINE B	VNF1113

J DISPLAY ASSY

SEMICONDUCTORS

IC2201	BU2092F
IC2202	TC74HC123AF
IC2203	TC7S32F
△ Q2203	2SA1036K
Q2202	2SC2412K
Q2205,Q2206	2SD2114K
Q2201,Q2204	DTC124EK
D2201	1SS355
D2203-D2213	SLP6118C51H
D2202	SLR-343VC(NPQ)

FILTERS

F2201-F2204	CHIP BEAD	DTF1070
-------------	-----------	---------

SWITCHES

S2219	ASD7013
S2202-S2218	VSG1009

CAPACITORS

C2205 (3.3μF/25V)	ACH7027
C2220,C2226	CEWAS100M50
C2201,C2203,C2224	CEWAS470M16
C2227	CKCYF103Z50
C2202,C2204,C2206-C2219	CKSQYB104K25
C2221-C2223	CKSQYB104K25
C2225	CKSQYB473K50

RESISTORS

R2242	RD1/2LMF103J
Other Resistors	RS1/10S□□□J

Mark	No.	Description	Part No.
OTHERS			
	CN2201	FFC CONNECTOR 28P	28FMZ-ST
	V2201	FL TUBE	AAV7065
	J2202	CONNECTOR ASSY 4P	ADX7275
	J2203	CONNECTOR ASSY 12P	ADX7276
	2201	REMOTE RECEIVER UNIT	GP1U27X
		PCB BINDER	VEF1040

K VOLUME ASSY

SEMICONDUCTORS

IC2601	TA8409S
D2601	1SS355

COILS AND FILTERS

F2601,F2602	CHIP BEAD	DTF1070
L2601,L2602		LFEA220J

CAPACITORS

C2606,C2607	CEBA100M50
C2601,C2602,C2604,C2605,C2608	CKSQYB104K25
C2603 (220 μ F/25V)	PCH1128

RESISTORS

VR2601	MOTOR VOLUME	ACX7036
	Other Resistors	RS1/10S□□□J

OTHERS

CN2601	KR CONNECTOR	S7B-PH-K-S
KN2601	EARTH METAL FITTING	VNF1084

L ENC A ASSY

SWITCH

S2401	ASX7022
-------	---------

CAPACITORS

C2403	CKSQYB104K25
C2401,C2402	CKSQYB473K50

RESISTORS

All Resistors	RS1/10S□□□J
---------------	-------------

OTHERS

J2401	CONNECTOR ASSY 8P	ADX7277
-------	-------------------	---------

M INPUT SW ASSY

SWITCH

S2301	ASD7012
-------	---------

RESISTORS

All Resistors	RS1/10S□□□J
---------------	-------------

OTHERS

J2302	PCB BINDER	AEF7006
	EARTH LEAD UNIT	DE005WE0

Mark	No.	Description	Part No.
N ENC B ASSY			
SWITCH			
	S2501		ASX7022
CAPACITORS			
	C2503		CKSQYB104K25
	C2501,C2502		CKSQYB473K50
RESISTORS			
	All Resistors		RS1/10S□□□J
OTHERS			
	CN2501	KR CONNECTOR	S5B-PH-K-S

6. ADJUSTMENT

There is no information to be shown in this chapter.

7. GENERAL INFORMATION

7.1 DIAGNOSIS

7.1.1 Test Mode

(1) How to enter the test mode

Turn the OUTPUT MODE switch to "OFF" in the POWER OFF state, and turn the POWER ON. Enter the test mode that continues pressing "DIGITAL NR", "TONE" and "REC SELECTOR" keys together for two seconds after passing afterwards more than 15 seconds (In the meantime, because do not accept key operation).

Indicate it with "TEST MODE" in FL.

Set all states to the factory setting state except destination code.

SACD, HDCD lights during test mode.

(2) FL All lights / All lights out

Enter the FL and LED light confirmation mode when pressing the "NETWORK SETUP + DIRECT" keys during test mode.

Change the FL indication and LED indication as follows whenever pressing the "NETWORK + DIRECT" keys.

Normal indication → FL, LED all light → FL, LED all light out → Normal indication → ...

(3) Delay confirmation

FL indicates it with "DELAY CHECK" when pressing the "NETWORK SETUP + Hi-bit" keys during test mode and it beomes following setting.

- INPUT selector set to the MULTI-ch mode with the DVD.
- As for the setting of delay, FRONT ch and CENTER ch are 3.0m (10 feet), SURROUND ch is 1.5m (5 feet), and SURROUND ch delays 5 msec only.

Note: Please turn a little MASTER VOLUME after this.

(4) Gain switching confirmation in TONE on/off

Enter the gain switching confirmation mode of analog circuit when pressing the "NETWORK SETUP + MIDNIGHT" keys during test mode.

Switch as follows whenever pressing the "NETWORK + MIDNIGHT" keys.

Gain +6dB (last state) → gain 0dB → gain +6dB → ...

(5) Master VOLUME operation confirmation

Enter the operation confirmation mode of master VOLUME when pressing the "NETWORK SETUP + DIGITAL NR" keys during test mode.

Switch as follows whenever pressing the "NETWORK+DIGITAL NR" keys.

(MIN) (MIN)

Last state → -∞ → -12dB → -∞ → ...

(6) Communication confirmation with dts ROM

Enter the communication confirmation mode with dts ROM when pressing the "NETWORK SETUP + fs 96k/48k" keys during test mode.

INPUT SELECTOR becomes "DIGITAL 6", then repeat virtual OPTION: on/off whenever pressing the "NETWORK + fs" keys. Indicate it with "DTS ON" at on, and decode of compression audio is possible.

Perform the decode operation when inputs the dts signal in this state. If a communication with the dts ROM is performed, outputs it correctly decoded.

Note: Please turn a little MASTER VOLUME after this.

(7) How to cancel the test mode

Turn the POWER OFF, then finish the above operations and cancel the test mode.

(8) Microcomputer version confirmation

Turn the OUTPUT MODE switch to "OFF" and turn the POWER ON. Indicates the version of the microcomputer (system controller and DSP controller) in the FL indicator that continues pressing "PARAMETER CHECK", "MIDNIGHT" and "REC SELECTOR" keys together for two seconds after passing afterwards more than 15 seconds.

Indication example: (System controller) SYS: ***
(DSP controller) DSP: ***

(9) Key list of the main unit to use

DIGITAL NR + TONE + REC SELECTOR : Enter the test mode

NETWORK SETUP + DIRECT : FL, LED all light / all light out confirmation mode

NETWORK SETUP + Hi-bit : Delay confirmation mode

NETWORK SETUP + MIDNIGHT : TONE gain switching confirmation mode

NETWORK SETUP + DIGITAL NR : Master VOLUME operation confirmation

NETWORK SETUP + fs 96k/48k : dts ROM operation confirmation

PARAMETER CHECK + MIDNIGHT + REC SELECTOR : Microcomputer version confirmation

7.1.2 Troubleshooting

Firstly confirm that connection of each connector and FFC are correctly.

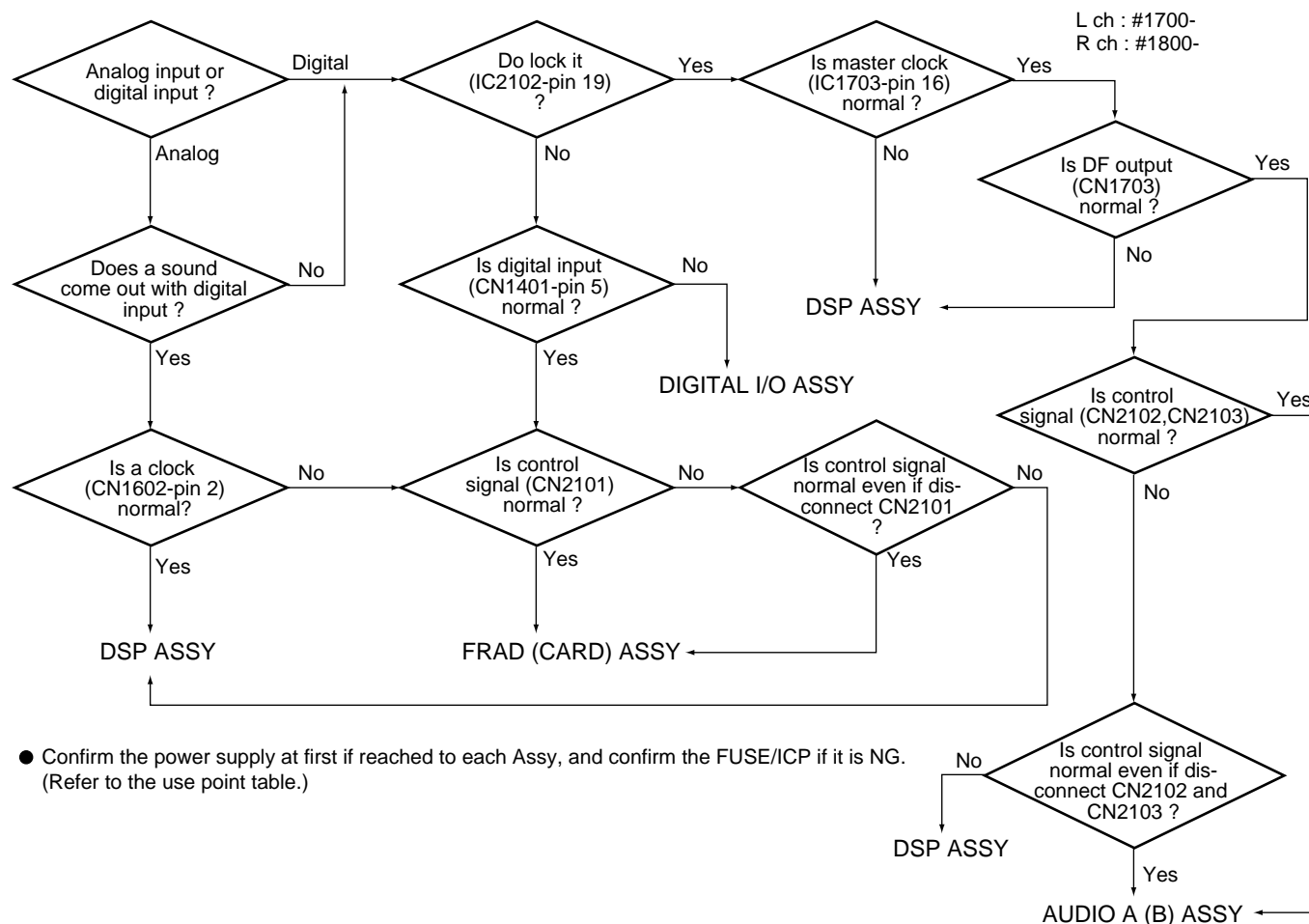

● Use point table of FUSE/ICP

FUSE/ICP No.	Part No.		Use Point	Assy Name
	KU/CA Type	NY Type		
FU101	VEK1023 (4A 125V)	REK-106 (T4AL250V)	Primary side	AC ASSY
FU201	VEK1023 (4A 125V)	REK-106 (T4AL250V)	DSP winding	PS ASSY
FU202	VEK1023 (4A 125V)	REK-106 (T4AT250V)	Digital winding	PS ASSY
IC201	AEK7006 (630mA)	AEK7006 (630mA)	FLAC winding	PS ASSY
IC202	AEK7006 (630mA)	AEK7006 (630mA)	FLAC winding	PS ASSY
IC203	AEK7006 (630mA)	AEK7006 (630mA)	FL winding	PS ASSY
IC304	AEK7006 (630mA)	AEK7006 (630mA)	P-OFF	FRAD ASSY
IC401	ICP-N25 (1A)	ICP-N25 (1A)	Audio +25V (VC25)	FRAD ASSY
IC402	ICP-N25 (1A)	ICP-N25 (1A)	Audio -25V (VE25)	FRAD ASSY
IC403	AEK7016 (3.15A)	AEK7016 (3.15A)	Relay winding	FRAD ASSY
IC405	AEK7010 (1.25A)	AEK7010 (1.25A)	Regulator input (VC9) for A/D +3.3V	FRAD ASSY
IC407	ICP-N25 (1A)	ICP-N25 (1A)	Regulator input (VC9) for A/D +5V	FRAD ASSY
IC408	AEK7023 (200mA)	AEK7023 (200mA)	Regulator input (VV5) for DAC VOL +5V	FRAD ASSY
IC409	ICP-N25 (1A)	ICP-N25 (1A)	Regulator input (VC9) for D/A +5V	FRAD ASSY
IC410	ICP-N25 (1A)	ICP-N25 (1A)	Regulator input (VC9) for D/A -5V	FRAD ASSY
IC411	AEK7006 (630mA)	AEK7006 (630mA)	Relay (analog input) +17V (VR17)	FRAD ASSY
IC412	AEK7006 (630mA)	AEK7006 (630mA)	Relay (analog output L ch) +17V (VR17)	FRAD ASSY
IC413	AEK7006 (630mA)	AEK7006 (630mA)	Relay (analog output R ch) +17V (VR17)	FRAD ASSY

7.1.3 Power ON Sequence

■ Main Microcomputer (1/2) (IC2109)

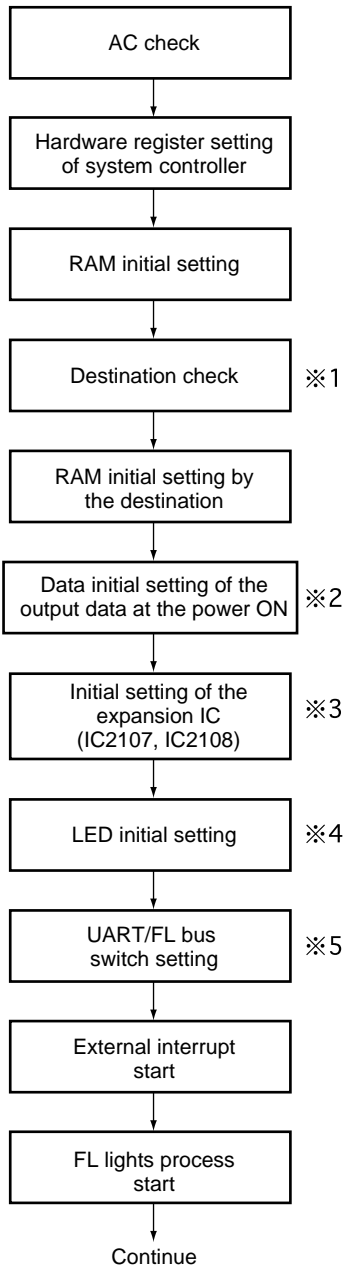

※1 Destination check

Port 70 (I/O ST)	Destination
H	KU/CA
L	NY

Distinction of the speaker distance "m" and "feet".

Use port 70 as a destination port only in the power ON state, and use it as a strobe port of the expansion IC in normal state.

※2 Data initial setting of the output data at the power ON

Port	Setting
24 DISPOFF	H
66 OE	L

※3 Expansion IC initialized

IC2107			
Port	Setting		
4 Q1	MT10 L		
5 Q2	MT20 L		
6 Q3	MT11 L		
7 Q4	MT3I L		
11 Q8	L		
12 Q7	XVUP L		
13 Q6	MT2I L		
14 Q5	MTDI L		

IC2108			
Port	Setting		
4 Q1	DOFF L		
5 Q2	G+-6 L		
6 Q3	XPHN L		
7 Q4	G-06 L		
11 Q8	VOL- L		
12 Q7	VOL+ L		
13 Q6	LFEG L		
14 Q5	XDIV L		

※4 LED data initialized

IC2107			
Port	Setting		
5 Q0	DG5I L		
6 Q1	DG4I L		
7 Q2	DG3I L		
8 Q3	DG2I L		
9 Q4	DG6I L		
10 Q5	DIFI L		
11 Q6	DG1I L		
12 Q7	AN3I L		
13 Q8	AN2I L		
14 Q9	AN1I L		
15 Q10	DVDI L		
16 Q11	DISP L		

L : Lights out
H : Lights

※5 UART/FL bus switch

	Port 12 (XVUP) of IC2107
In normal use	H
In memory rewriting	L

■ Main Microcomputer (2/2) (IC2109)

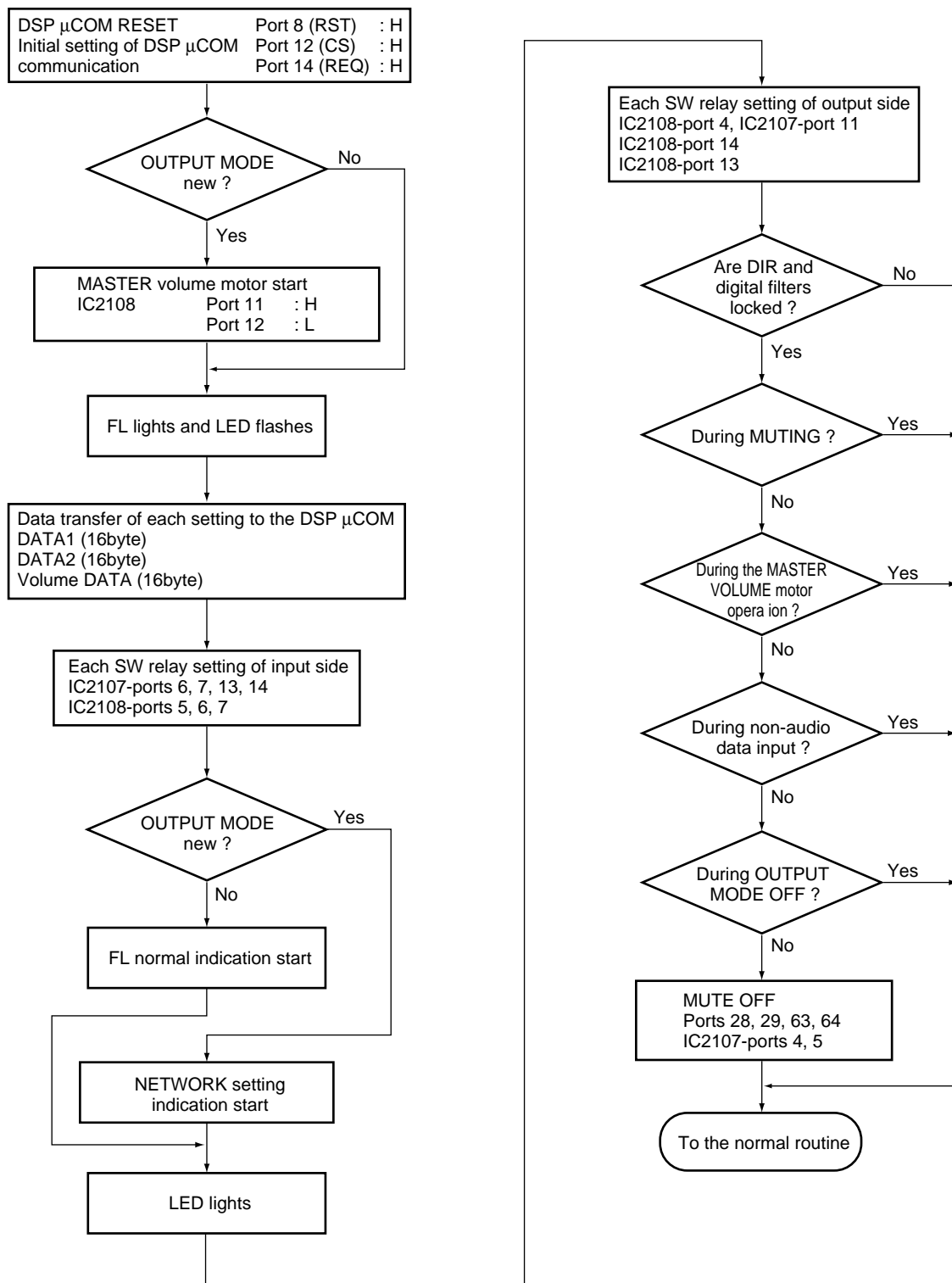

■ DSP Control Microcomputer (IC2102)

• POWER ON

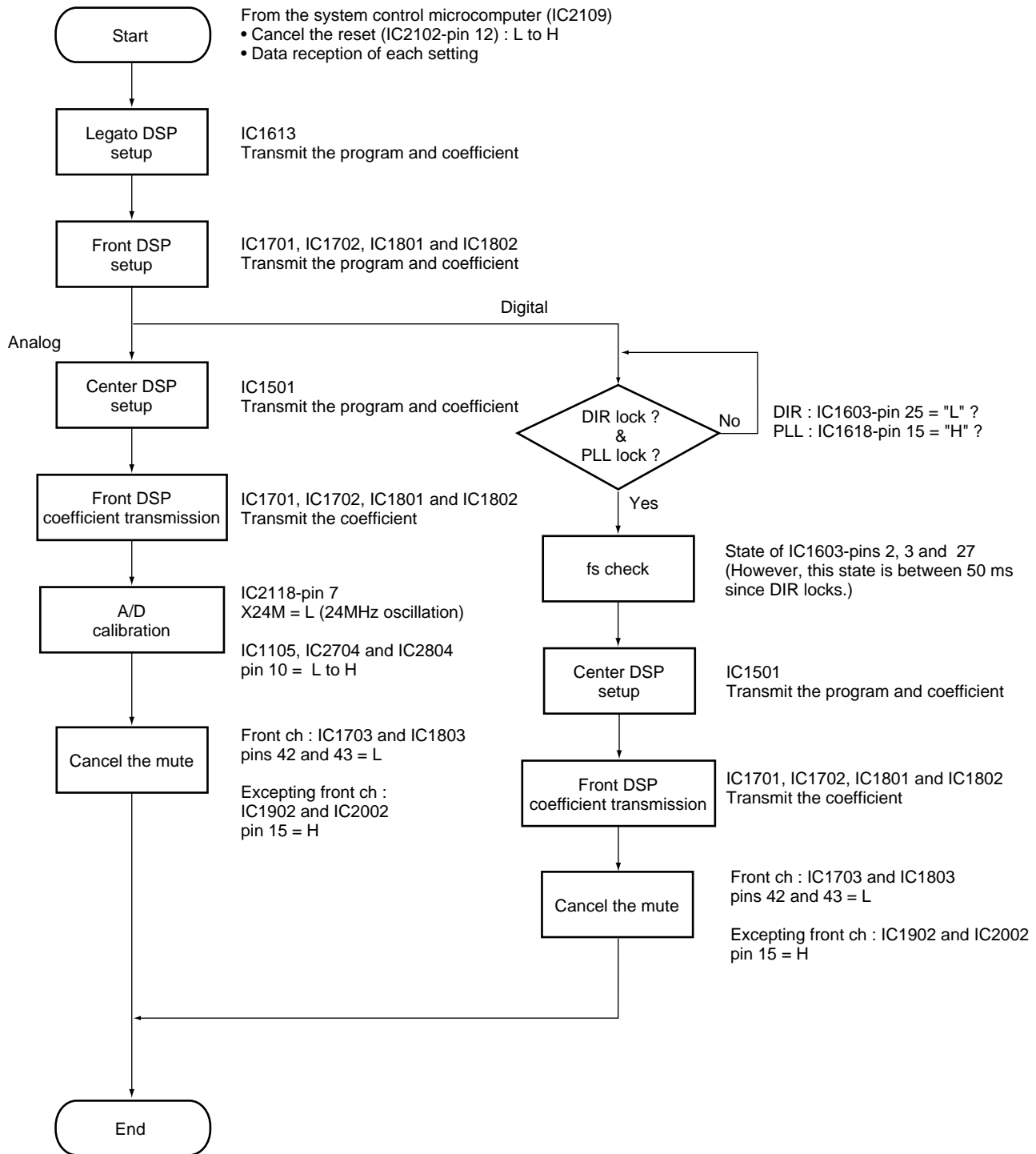

• Input switch (Analog to Digital)

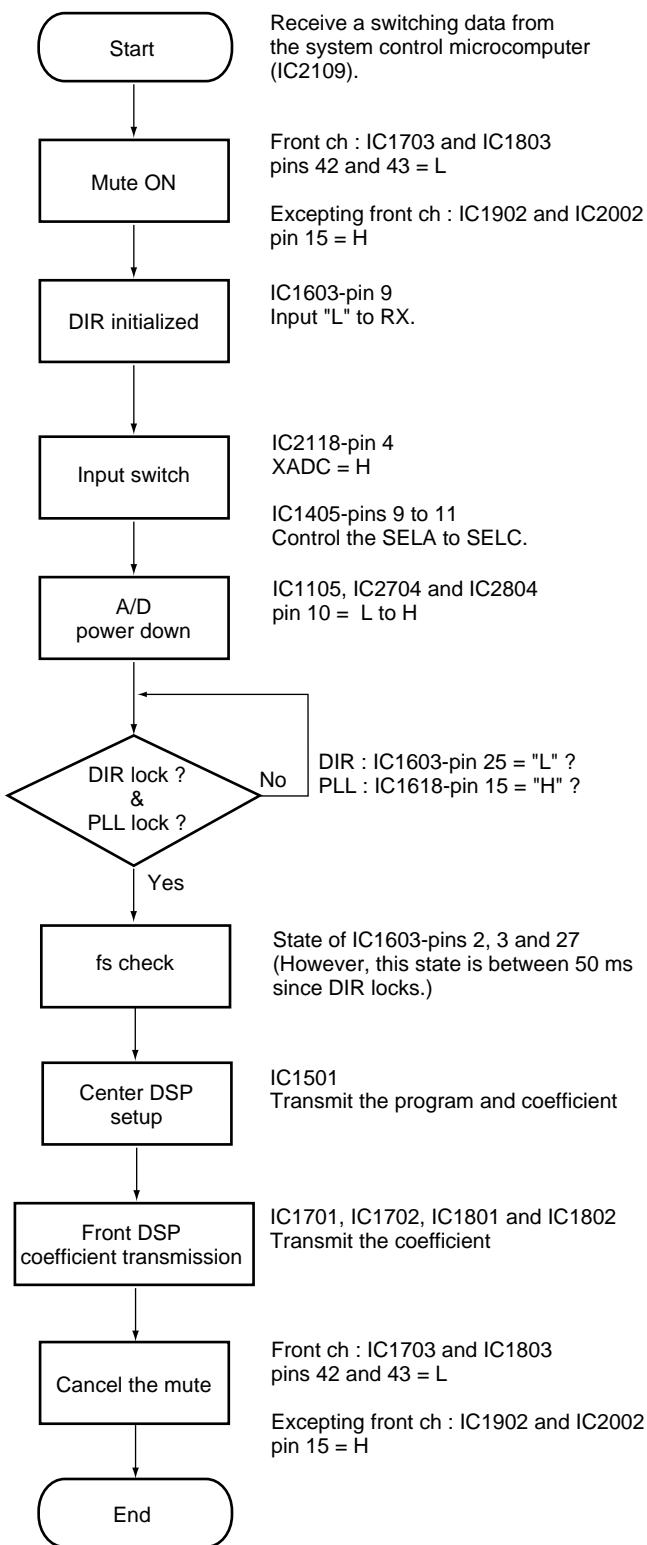

• Input switch (Digital to Analog)

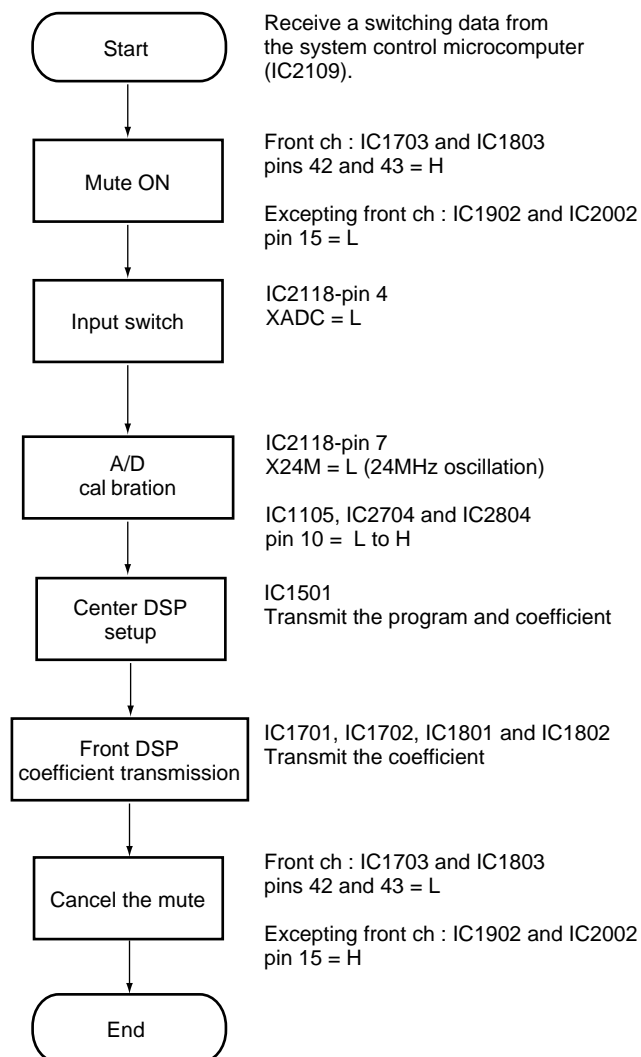

7.1.4 Disassembly

■ Top Plate, Side Alum. L and R

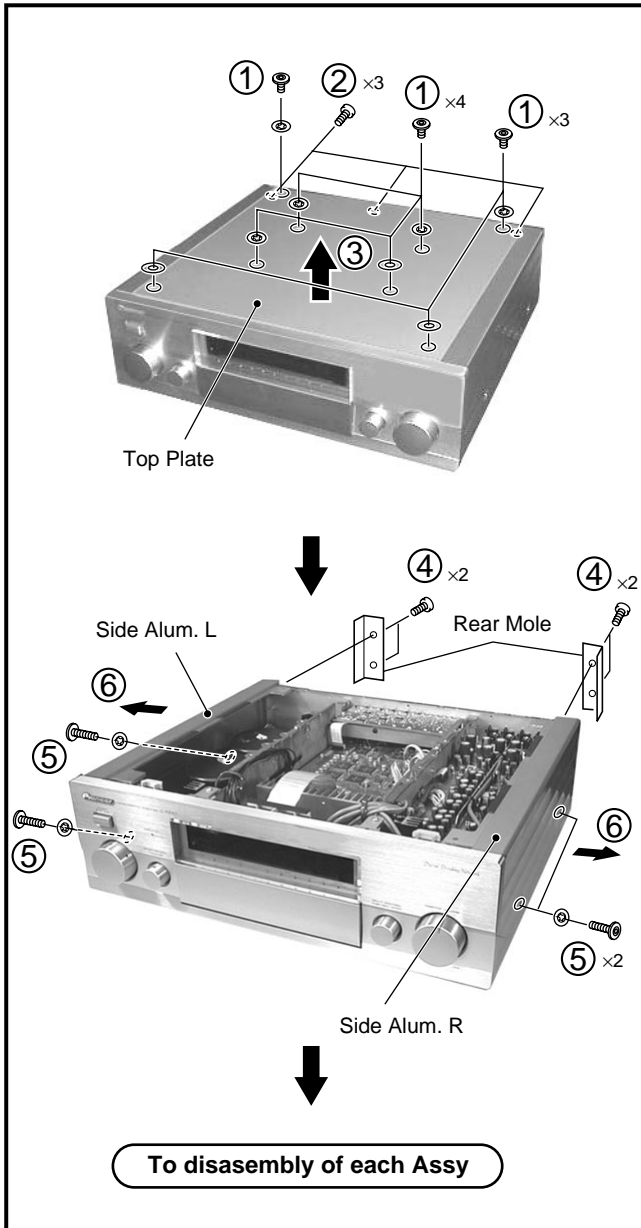

■ AUDIO A ASSY

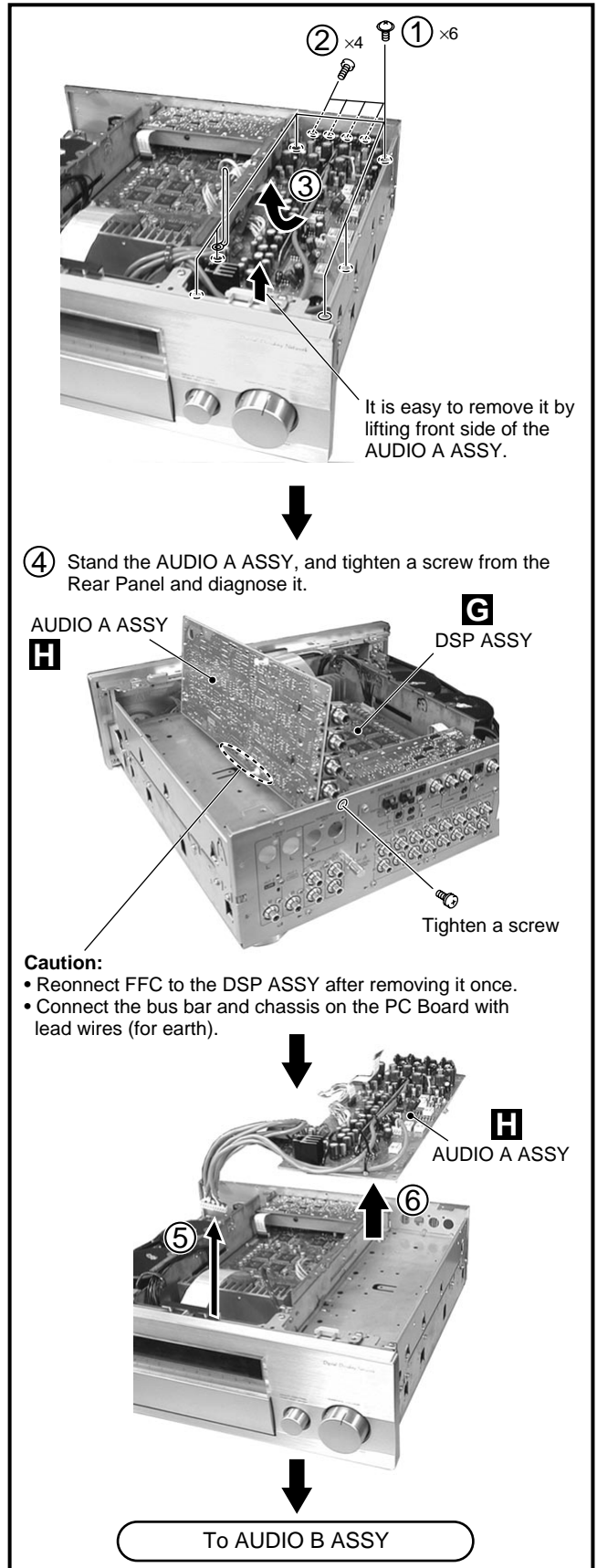

■ AUDIO B ASSY

① Remove the AUDIO A ASSY.

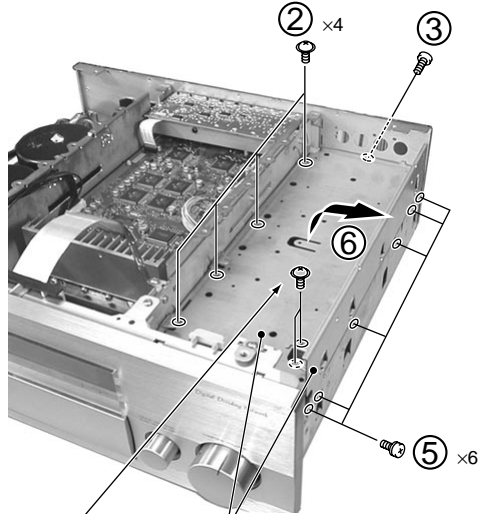

Remove the Sub Chassis and Side Frame A together.

④ x2
Remove a PCB Holder after removing two screws.

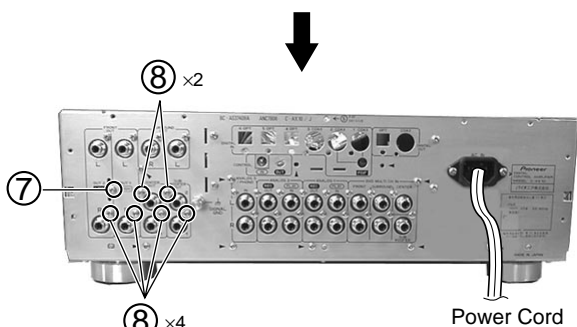

Power Cord

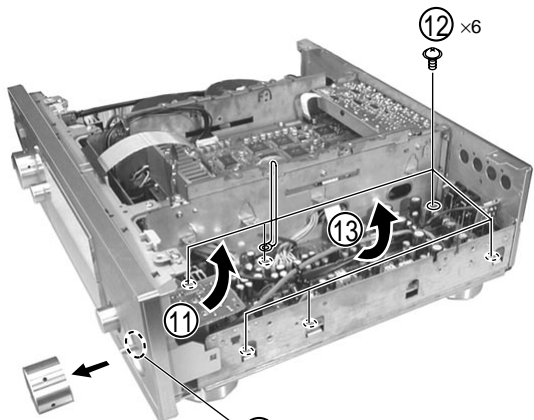

⑩ Remove a Nut.
Loosen two screws and remove a Rotary Knob L.

⑭ Stand the AUDIO B ASSY and diagnose it.
(AUDIO B ASSY works even if removes the AUDIO A ASSY.)

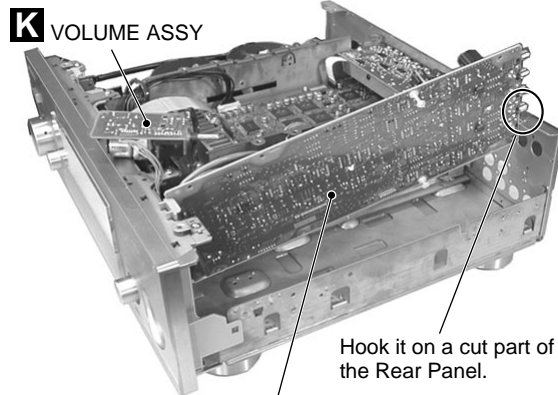

I AUDIO B ASSY

Caution:

- Fix the SG ASSY to the suitable place with a screw (for earth).
- Reconnect FFC to the DSP ASSY after removing it once.

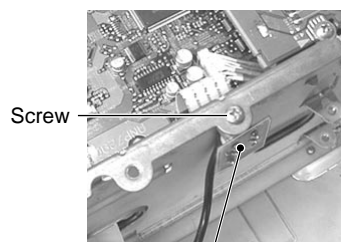

Screw

D SG ASSY

● Styling in installation
(AUDIO A and AUDIO B ASSYS)

Caution: Perform styling if possible to under side.
(do not seem to rise to upper side)

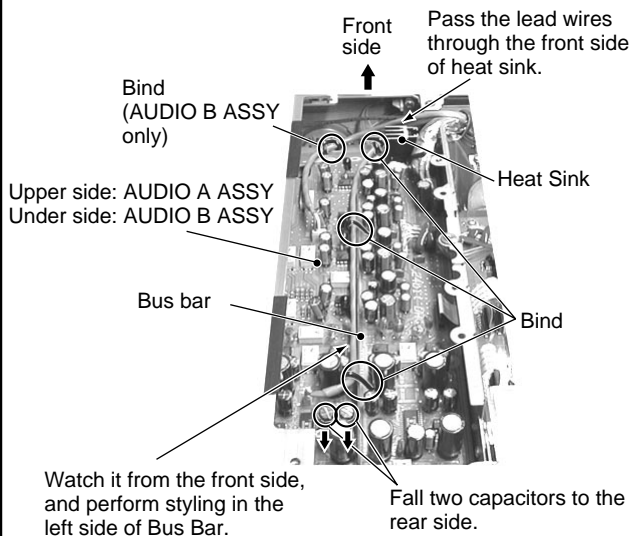

■ DIGITAL I/O and DSP ASSYS

① x8 (DIGITAL I/O ASSY)

(DSP ASSY) ② x2 Power Cord

Shield Plate H ③ x2

④ ⑤ ④ ⑥ x4

A DIGITAL I/O ASSY

DSP ASSY

G ⑦ Remove all connectors to connect the AUDIO A and AUDIO B ASSYS.

⑨ Stand the DSP ASSY and diagnose it.

■ When diagnosing one section of the microcomputer and digital input and output system

A DIGITAL I/O ASSY

G Connect

Fix the PC Board with a screw in "Ⓢ For service" on the Rear panel.

COAX 2 COAX 1 COAX

■ When diagnosing the analog input and output system

All diagnoses are completed when connects the DIGITAL I/O ASSY.

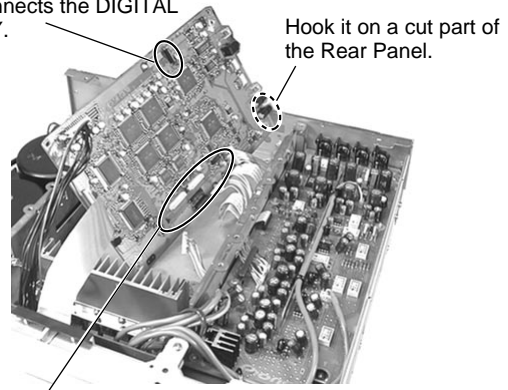

Connect all connectors from the AUDIO A and AUDIO B ASSYS.

■ When diagnosing the A/D section of the FRAD ASSY

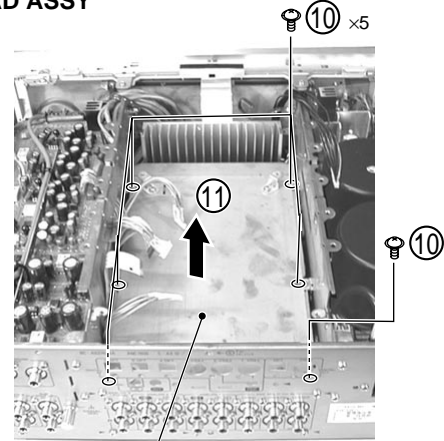

Main Shield

⑫ Install the DSP ASSY.

Connect all connectors to the DISPLAY ASSY.

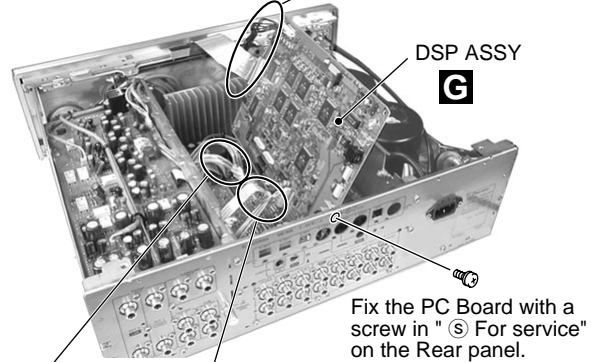

Connect all connectors to the FRAD ASSY.

May remove the connectors to the AUDIO A and AUDIO B ASSYS.

To FRAD ASSY

● Styling in installation (DSP ASSY)

Caution: Perform styling so that each wire does not come near.

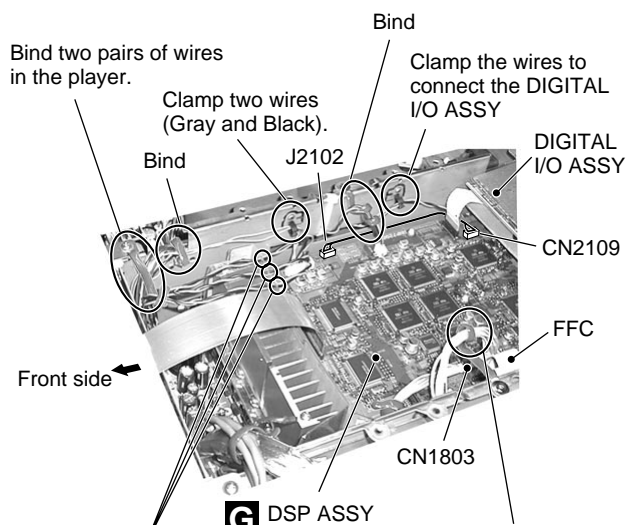

Pass a wire through a slit of the shield plate every one set (three sets).

Note:
It becomes an equal interval wires of each group.

Bind in upper side of CN1803. Keep distance with wire of CN1803 and FFC away and bind it.

■ FRAD ASSY

① Remove the DIGITAL I/O ASSY, DSP ASSY and Main Shield.

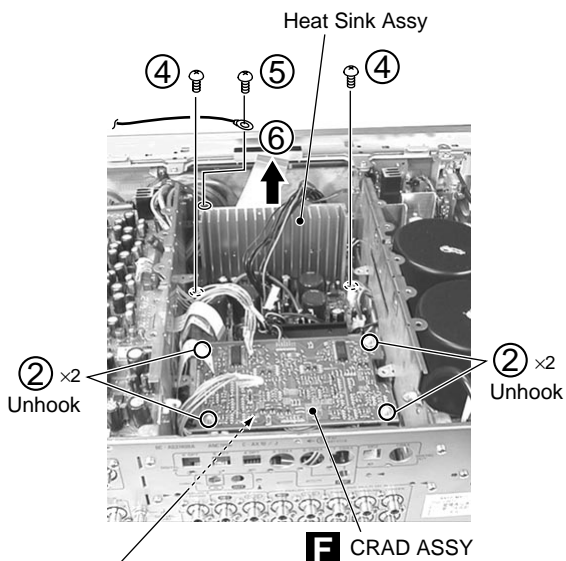

③ Remove the Shield Plate B where is in the bottom of CRAD ASSY. (Three screws)

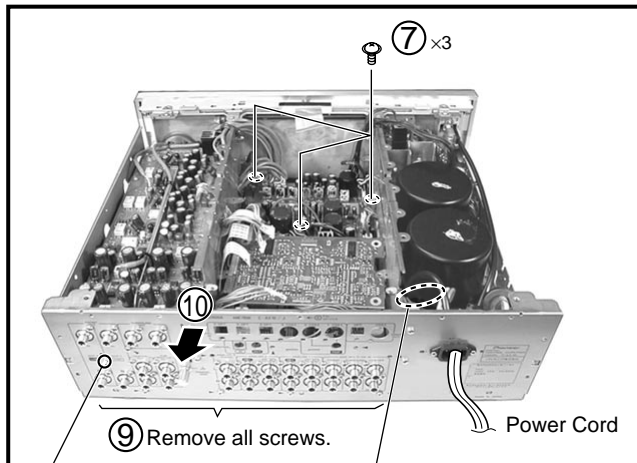

Note:
Do not remove a screw of the SG ASSY.

⑧ Remove a CN101 from the Power Cord.

⑪ Remove four connectors.

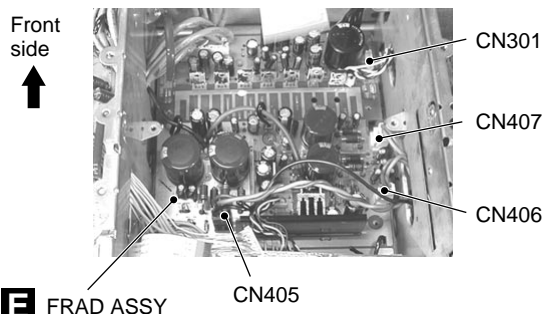

E FRAD ASSY

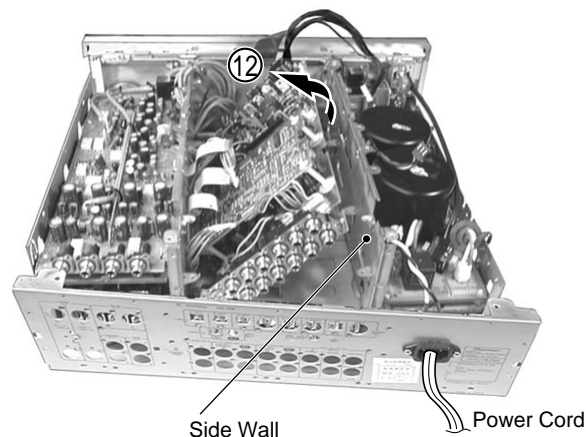

Note:
Slide the PC Board to rear slide (2 or 3 cm away) after removing screws, connectors, Heat Sink ASSY and Rear Panel. And PC Board can lift to upper side when matches a projection part of the Side Wall with a cut part of the PC Board.

■ Power Transformer (T301, T401)

■ When replacing the Analog Transformer (T401)
(① to ⑤)

- ① Remove the DIGITAL I/O ASSY, DSP ASSY and Main Shield.
- ② Remove three connectors.

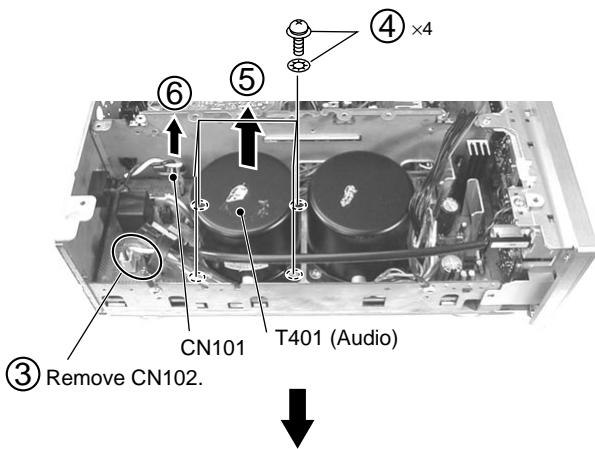
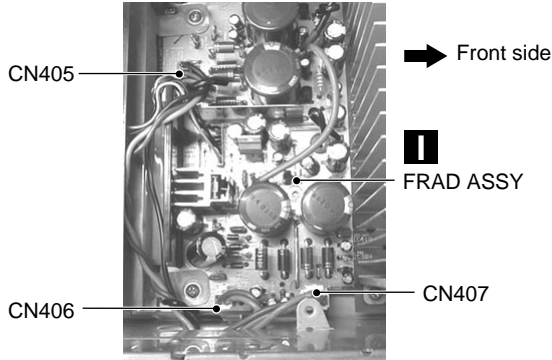

- ③ Remove CN102.

■ When replacing the Digital Transformer (T301)
(⑦ to ⑱)

- ⑦ x2
 - ⑧
 - ⑨
 - ⑩
 - ⑪ Remove two connectors.
 - ⑫ Unhook three PCB Supports.
 - ⑬
 - ⑭
 - ⑮
 - ⑯
 - ⑰
 - ⑱
- AC ASSY
- PS ASSY
- Unhook two PCB Supports.

⑭ x7

AC ASSY

⑮ Cut a Binder (ZCA-BK1).

Subchassis B2

⑰ x4

⑱

T301 (Digital)

⑯

UL Tube (KU/CA type only)

⑰ x3 Unhook

● Styling in installation (PS ASSY)

T301 (Digital)

Front side

Diode

PS ASSY

Bind two wires (Blue/Black).

Press down five wires except blue and black wires to under side with a binder of PS ASSY.

Bind two wires (Green/Brown) (Be careful not to touch the diode.)

Caution: Keep Blue/Black wires, Green/Brown wires and other five wires away each other, and perform styling.

■ Front Panel Section

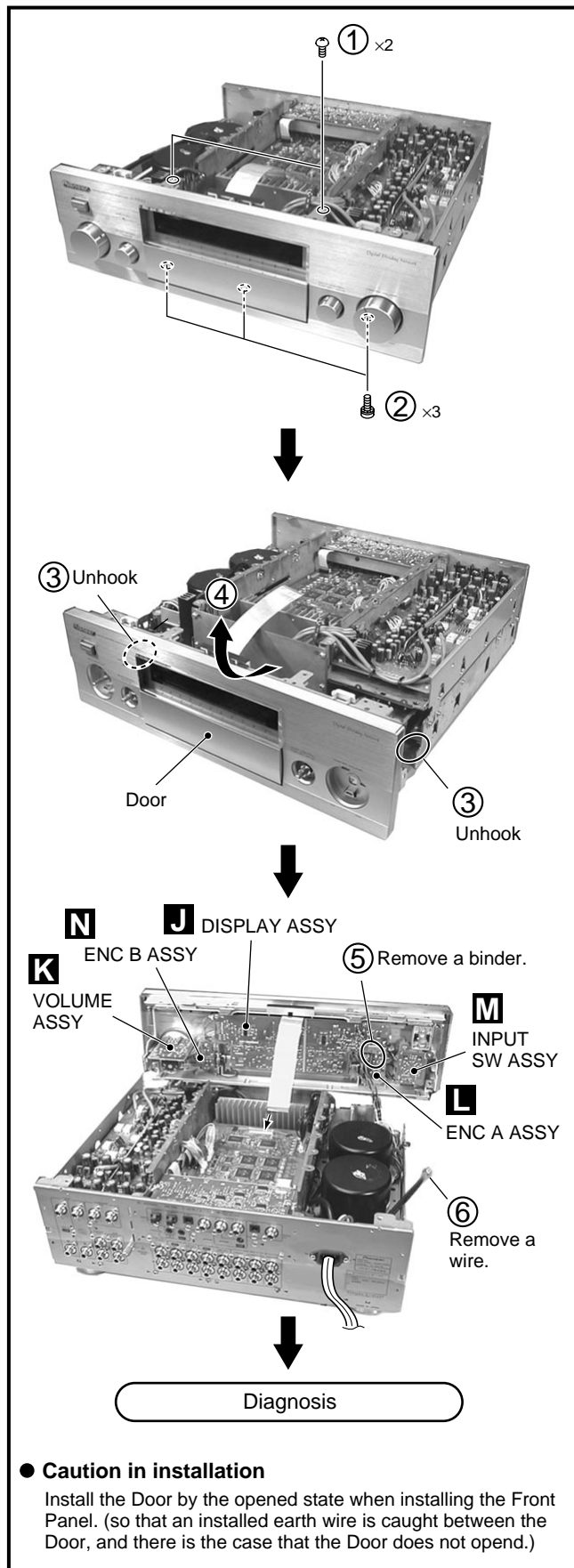

7.1.5 PCB LAYOUT

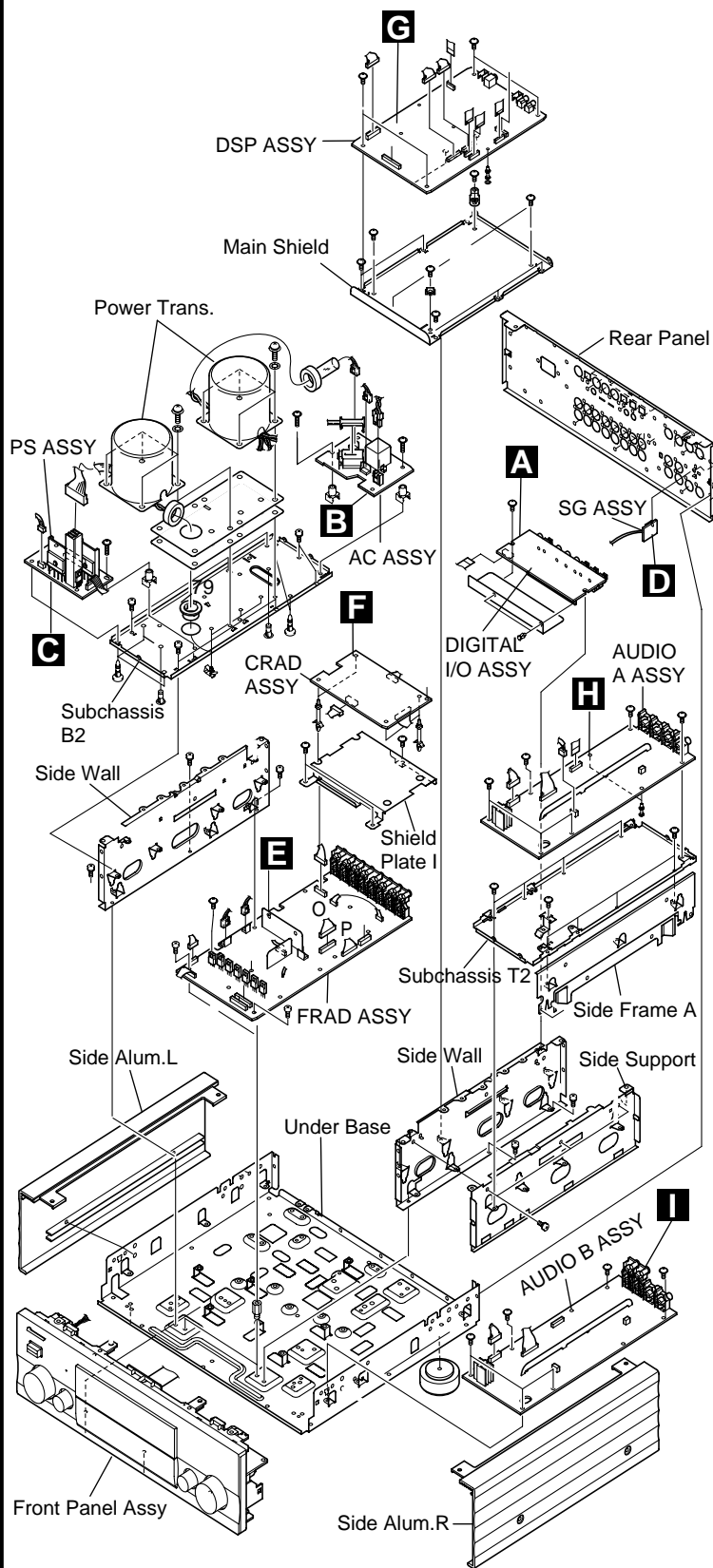

7.2 PARTS

7.2.1 IC

• The information shown in the list is basic information and may not correspond exactly to that shown in the schematic diagrams.

• List of IC

TC74VHC257FT, TC74VHC244F, TC7WT74FU, TC74VHC4040FT, TC74VHC153FT, TC74VHC157F, TC74VHC163FT, DF1704E, BC4094BCFV, TC7W126FU, AT24C16N-10SI2.5, M30622SFP, M38079SFP, AK5393VS

■ TC74VHC257FT (DSP ASSY : IC1505)

• Quad 2-Channel Multiplexer (3-state)

• Block Diagram

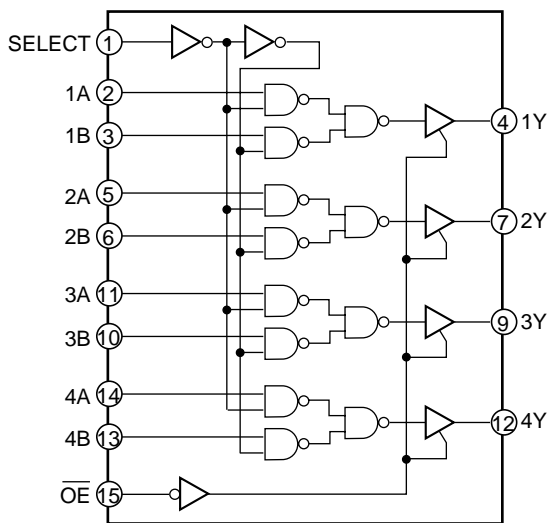

• Truth Table

INPUTS				OUTPUTS
OE	SELECT	A	B	
H	X	X	X	Z
L	L	L	X	L
L	L	H	X	H
L	H	X	L	L
L	H	X	H	H

X : Don't Care
Z : High Impedance

■ TC74VHC244F (DSP ASSY : IC1506)

• Octal Bus Buffer

• Pin Arrangement (Top view)

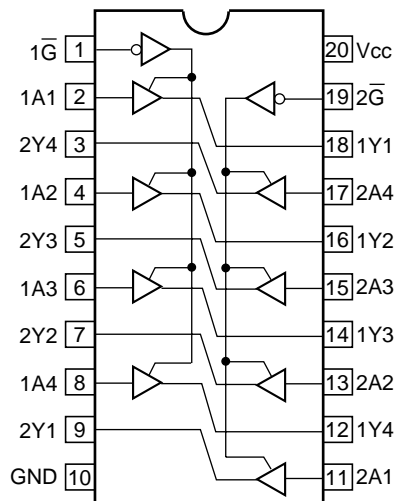

• Truth Table

INPUTS		OUTPUTS
G	An	Yn
L	L	L
L	H	H
H	X	Z

X : Don't Care
Z : High Impedance
Yn : TC74VHC244F

TC7WT74FU (DSP ASSY : IC1605)

• D-type Flip Flop with Present and Clear

• Pin Arrangement (Top view)

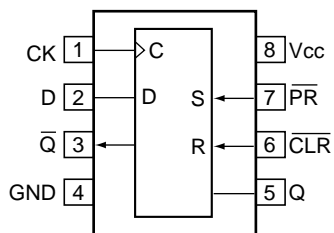

• Truth Table

INPUTS				OUTPUTS		FUNCTION
CLR	PR	D	CK	Q	Q	
L	H	X	X	L	H	CLEAR
H	L	X	X	H	L	PRESET
L	L	X	X	H	H	---
H	H	L		L	H	---
H	H	H		H	L	---
H	H	X		Qn	Qn	NO CHANGE

X : Don't Care

TC74VHC4040FT (DSP ASSY : IC1606, IC1623)

• 12-stage Ripple-carry Binary Counter

• Block Diagram

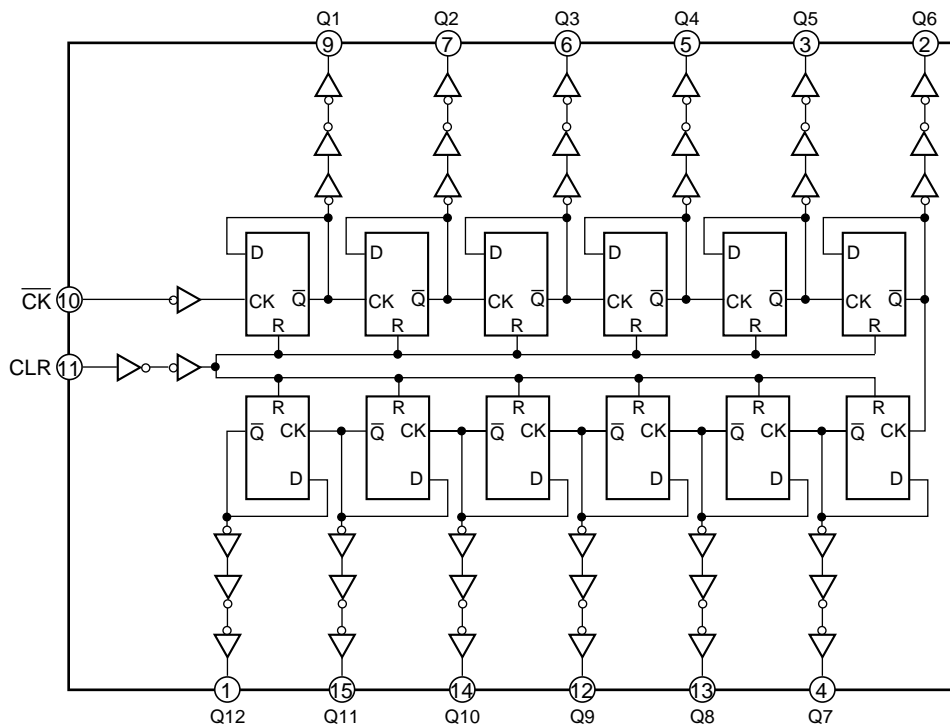

• Truth Table

CK	CLR	Output State
X	H	All outputs "L"
	L	Don't change
	L	Go to the next state

X : Don't Care

■ TC74VHC153FT (DSP ASSY : IC1614)

• Dual 4-channel Multiplexer

• Block Diagram

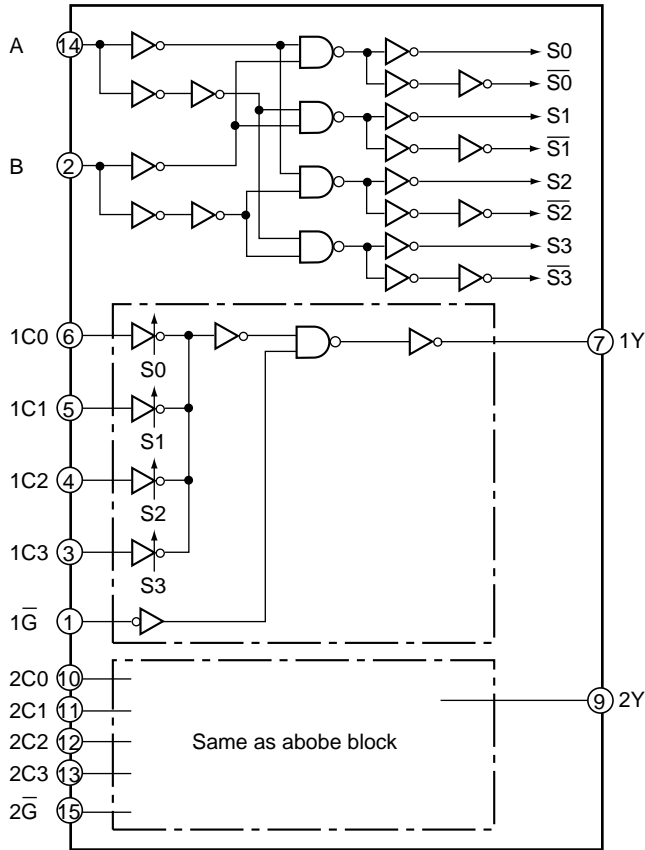

• Truth Table

SELECT INPUTS		DATA INPUTS				STROBE	OUTPUT
B	A	C0	C1	C2	C3	\overline{G}	Y
X	X	X	X	X	X	H	L
L	L	L	X	X	X	L	L
L	L	H	X	X	X	L	H
L	H	X	L	X	X	L	L
L	H	X	H	X	X	L	H
H	L	X	X	L	X	L	L
H	L	X	X	H	X	L	H
H	H	X	X	X	L	L	L
H	H	X	X	X	H	L	H

X : Don't Care

■ TC74VHC157F (DSP ASSY : IC1704, IC1804, IC1903, IC2003)

• Quad 2-channel Multiplexer

• Block Diagram

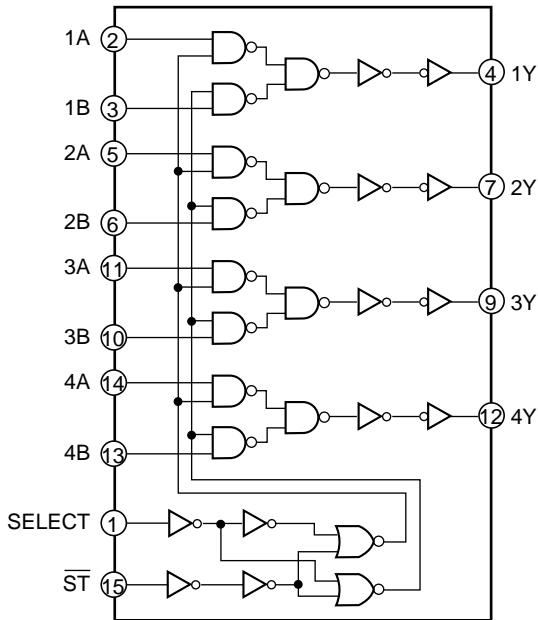

• Truth Table

INPUTS				OUTPUT
\overline{ST}	SELECT	A	B	
H	X	X	X	L
L	L	L	X	L
L	L	H	X	H
L	H	X	L	L
L	H	X	H	H

X : Don't Care

■ TC74VHC163FT (DSP ASSY : IC1620)

• Synchronous Presetable 4-bit Counter

● Block Diagram

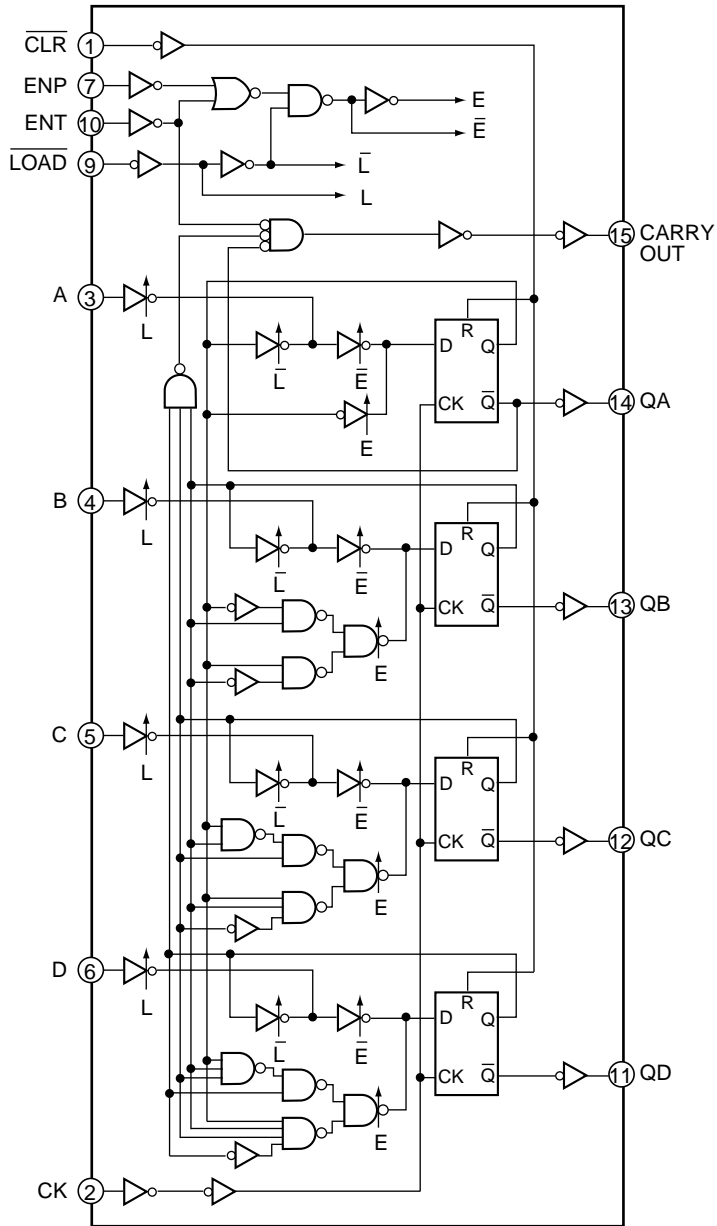

● Truth Table

D	CK	R	Q	\bar{Q}
X		H	L	H
L		L	L	H
H		L	H	L
X		X	*	*

X : Don't Care
 * : No Change

DF1704E (DSP ASSY : IC1902, IC2002)

- Digital Filter

- Block Diagram

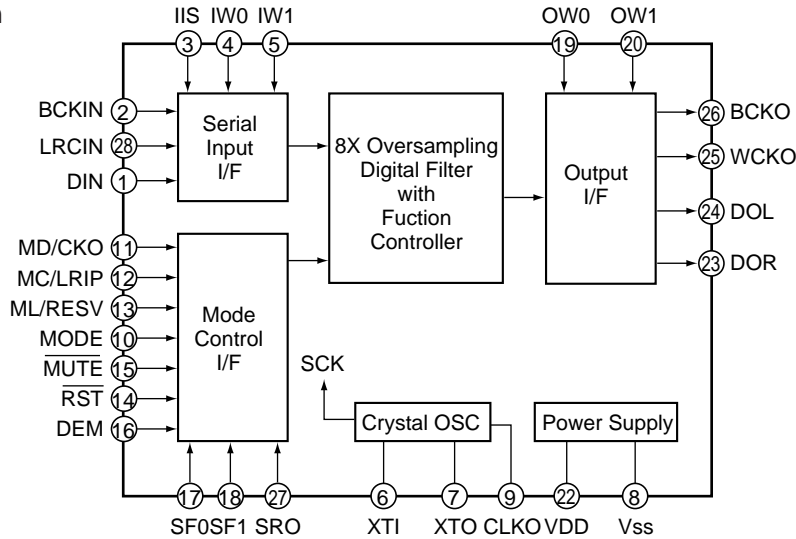

- Pin Function

No.	Pin Name	I/O	Pin Function
1	DIN	I	Serial audio data input
2	BCKIN	I	Bit clock input for serial audio data
3	IIS	I	Format selection of input audio data
4	IW0	I	Word selection of input audio data
5	IW1	I	Word selection of input audio data
6	XTI	I	Connect an oscillator or external clock input
7	XTO	O	Oscillator output
8	Vss	-	Ground
9	CLKO	O	Buffer output of system clock
10	MODE	I	Mode control selection (H: Software mode, L: hardware mode)
11	MD/CKO	I	Mode control, data / 1/2 divided clock selection
12	MC/LRIP	I	Mode control, clock / LRCIN polarity selection
13	ML/RESV	I	Mode control, latch, clock / Not used
14	RST	I	Reset It becomes reset state during this pin is L.
15	MUTE	I	Mute control
16	DEM	I	Deemphasis control
17	SF0	I	Deemphasis Sampling rate selection
18	SF1	I	Deemphasis Sampling rate selection
19	OW0	I	Data word selection of output audio
20	OW1	I	Data word selection of output audio
21	NC	-	Non connection
22	VDD	-	Power supply +5V
23	DOR	O	Serial audio data output of R ch
24	DOL	O	Serial audio data output of L ch
25	WCKO	O	Word clock output for serial audio data output
26	BCKO	O	Bit clock output for serial audio data output
27	SRO	I	Filter characteristic selection
28	LRCIN	I	L/R clock input (fs)

■ BU4094BCFV (DSP ASSY : IC2101, IC2107, IC2108, IC2118)

• Port Expander

• Block Diagram

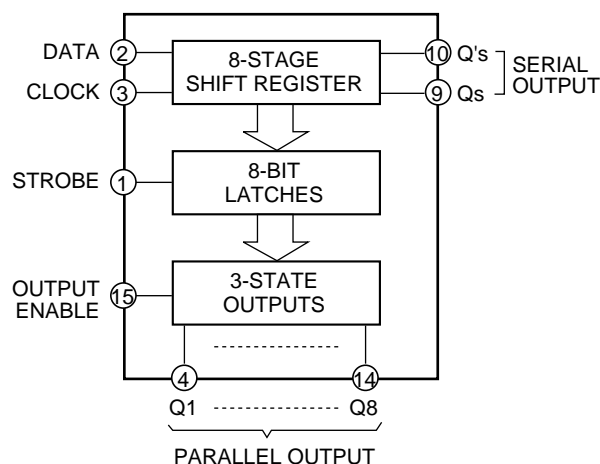

• Truth Table

CLOCK	OUTPUT ENABLE	STROBE	DATA	PARALLEL OUTPUTS		SERIAL OUTPUTS	
				Q1	Qn	Qs	Q's
↑	L	X	X	Z	Z	Qs	No Chg.
↓	L	X	X	Z	Z	No Chg.	Qs
↑	H	L	X	No Chg.	No Chg.	Q7	No Chg.
↑	H	H	L	L	Qn-1	Q7	No Chg.
↑	H	H	H	H	Qn-1	Q7	No Chg.
↓	H	X	X	No Chg.	No Chg.	No Chg.	Qs

X : Don't Care
Z : High Impedance

• Pin Function

No.	Mark	Pin Name	I/O	Pin Function
1	STROBE_	STB	I	Strobe input (IC2102 pin 23)
2	SERIAL IN	DATA	I	Serial data input (IC2102 pin21)
3	CLOCK	CLOCK	I	Serial clock input (IC2102 pin 22)
4	Q1	INPUT SEL 1	O	INPUT selector 1
5	Q2	INPUT SEL 2		INPUT selector 2
6	Q3	INPUT SEL 3		INPUT selector 3
7	Q4	192KHz	O	192kHz playback H: PDIF 192kHz signal
8	VSS	VSS	-	VSS
9	QS	QS	O	Connect to pin 2 (DATA) of IC2118
10	QS'	QS'	O	Not used
11	Q8	HI-BIT	O	Hi-bit playback H: Hi-bit playback
12	Q7	REC SEL 3	O	REC selector 3
13	Q6	REC SEL 2		REC selector 2
14	Q5	REC SEL 1		REC selector 1
15	OUTPUT ENABLE	OE	I	Chip enable input (IC2102 pin 28)
16	VDD	VDD	-	VDD

■ TC7W126FU (DSP ASSY : IC2103, IC2114)

• Dual Bus Buffer

• Pin Arrangement (Top view)

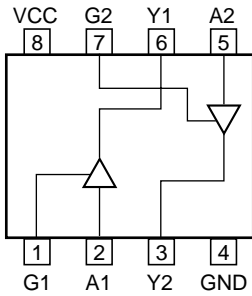

• Truth Table

INPUTS		OUTPUTS
G	A	Y
L	X	Z
H	L	L
H	H	H

X : Don't Care
Z : High Impedance

■ AT24C16N-10SI2.5 (DSP ASSY : IC2106)

• 2-wire Serial CMOS EEPROM

• Block Diagram

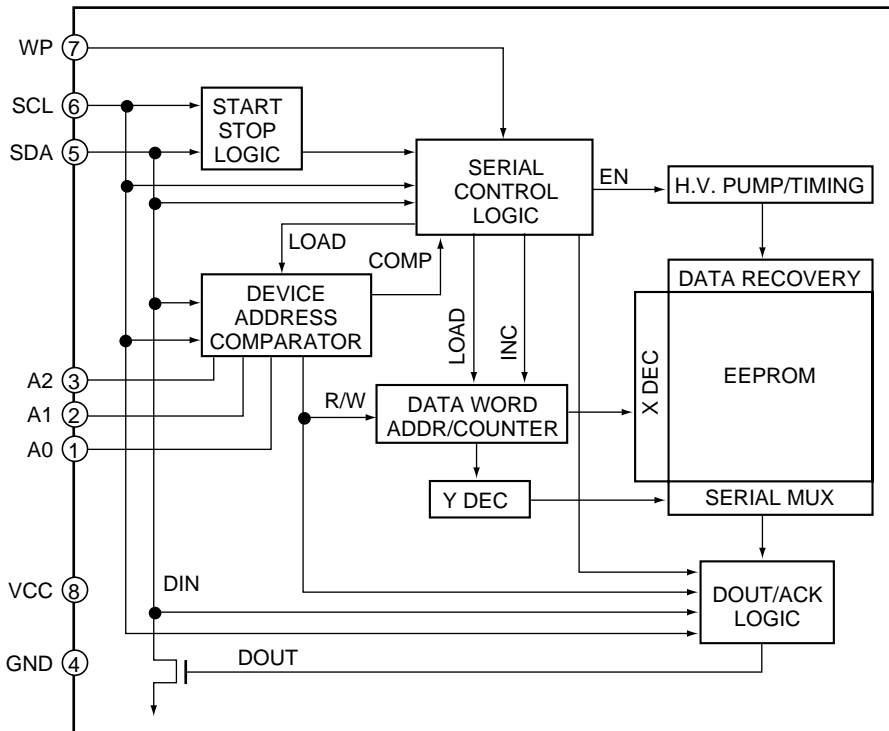

• Pin Function

No.	Pin Name	Pin Function
1	A0	Address input
2	A1	
3	A2	
4	GND	Ground
5	SDA	Serial data
6	SCL	Serial clock input
7	WP	Write protect
8	VCC	Power supply

■ M30622SFP (DSP ASSY : IC2102)

• DSP Microcomputer

● Pin Function

No.	Mark	Pin Name	I/O	Pin Function
1	P96/ANEX1/SOUT4	DSP MOSI	O	DSP communication data output (→DSP)
2	P95/ANEX0/CLK4	DSP SCK	O	DSP communication clock output
3	P94/DA1/TB4IN	DF DEM	O	Deemphasis control of Surround and Center (IC1902 and IC2002) H: Deemphasis ON
4	P93/DA0/TB3IN	DSP HREQ1	I	DSP communication ready (←center DSP) H: Communication busy
5	P92/TB2IN/SOUT3	DATA out	O	Communication data output of microcomputer (→main microcomputer)
6	P91/TB1IN/SIN3	DATA in	I	Communication data input of microcomputer (←main microcomputer)
7	P90/TB0IN/CLK3	CLOCK	I	Communication clock input of microcomputer
8	BYTE	BYTE	I	VOC (data length: 8 bit)
9	CNVSS	CNVSS	I	Pull-up to VCC (external memory use mode)
10	P87/XCIN	READY	O	Microcomputer communication ready (→main microcomputer) H: Communication busy
11	P86/XCOUT	HCS2	O	Microcomputer communication data request (→main microcomputer) L: Data request
12	RESET_	RESET	I	Reset input (←main microcomputer)
13	XOUT	XOUT	O	Connect a 7.7MHz ceramic resonator
14	VSS	VSS	-	VSS
15	XIN	XIN	I	Connect a 7.7MHz ceramic resonator
16	VCC	VCC	-	VCC
17	P85/NMI_	NMI	I	(Not used) →Pull-up to VCC
18	P84/INT2_	HCS1	I	Microcomputer communication data request (←main microcomputer) L: Data request
19	P83/INT1_	ERFM	I	Master DIR (IC1603) error H: unlock
20	P82/INT0_	ERFS	I	Slave DIR (IC1602) error H: unlock
21	P81/TA4IN/U_	S DATA	O	Serial data output
22	P80/TA4OUT/U	S CLOCK	O	Serial clock output
23	P77/TA3IN	EXSTB	O	Strobe output of expansion IC (IC2101 and IC2118) L: Strobe ON
24	P76/TA3OUT	ADPARA	O	A/D (IC1105, IC2704 and IC2804) 3-parallel operation L: Analog 2ch input
25	P75/TA2IN/W_	FADPD	O	Front A/D (IC1105) power down L: Power down
26	P74/TA2OUT/W	SSDF	O	Legato DSP (IC1613) communication strobe L: Strobe ON
27	P73/CTS2_/RTS2_/TA1IN/V_	HSEL	O	CLK selection of center DSP (IC1501) H: PDIF 48 kHz/24 bit multi-channel
28	P72/CLK2/TA1OUT/V	EXPOE	O	Output enable of expansion IC (IC2101 and IC2118) H: Output enable
29	P71/RXD2/SCL/TA0IN/TB5IN	X2CH	O	Digital filter (IC1903 and IC2003) reset of surround and center L: Reset
30	P70/TXD2/SDA/TA0OUT	PDIF	I	PDIF cable detection H: Cable exist
31	P67/TXD1	DDRST	O	Legato DSP (IC1613) reset L: Reset
32	P66/RXD1	FDRST	O	Front DSP (IC1701, IC1702, IC1801 and IC1802) reset L: Reset
33	P65/CLK1	VERUP	O	TC74HC125AF (IC2112) control L: Version up
34	P64/CTS1_/RTS1_/CTS0_/CLKS1	CTS	I	←P/C data request (version up) L: Communication ready
35	P63/TXD0	DATA out/ TXD (UART)	O	Data output (→PDIF mutual certification of DV-AX10) / data output (version up)
36	P62/RXD0	DATA in/ RXD (UART)	I	Data input (←PDIF mutual certification of DV-AX10) / data input (version up)
37	P61/CLK0		O	(Not used)
38	P60/CTS0_/RTS0_	RTS	O	→P/C data request (version up) L: Communication ready
39	P57/RDY_/CLKOUT	RDY_	I	(Not used) →Pull-up to VCC
40	P56/ALE	ALE	O	(Not used)
41	P55/HOLD_	HOLD_	I	(Not used) →Pull-up to VCC
42	P54/HLDA_	HLDA_		(Not used)
43	P53/BCLK	BCLK	O	(Not used)
44	P52/RD_	OE#	O	Output enable of Flash memory (IC2105) L: Output enable
45	P51/WRH_/BHE_	BHE_	O	(Not used)
46	P50/WRL_/WR_	WE#	O	Write enable of Flash memory (IC2105) L: Write enable
47	P47/CS3_		O	(Not used)
48	P46/CS2_		O	(Not used)
49	P45/CS1_	CFSEL	O	DIR (IC1603) CS/freq_ selection H: CS select
50	P44/CS0_	FLSHCS	O	CS control of Flash memory (IC2105) L: Chip enable

C-AX10

No.	Mark	Pin Name	I/O	Pin Function
51	P43/A19	A19	O	(Not used)
52	P42/A18	A18	O	Communication address output of Flash memory (IC2105)
53	P41/A17	A17		
54	P40/A16	A16		
55	P37/A15	A15		
56	P36/A14	A14		
57	P35/A13	A13		
58	P34/A12	A12		
59	P33/A11	A11		
60	P32/A10	A10		
61	P31/A9	A9		
62	VCC	VCC	-	VCC
63	P30/A8(/-/D7)	A8	O	Communication address output of Flash memory (IC2105)
64	VSS	VSS	-	VSS
65	P27/A7(/D7/D6)	A7	O	Communication address output of Flash memory (IC2105)
66	P26/A6(/D6/D5)	A6		
67	P25/A5(/D5/D4)	A5		
68	P24/A4(/D4/D3)	A4		
69	P23/A3(/D3/D2)	A3		
70	P22/A2(/D2/D2)	A2		
71	P21/A1(/D1/D0)	A1		
72	P20/A0(/D0/-)	A0		
73	P17/D15/INT5_	DFRST	O	Front digital filter (IC1703 and IC1803) reset L: Reset
74	P16/D14/INT4_	DIR Ce/F2	I	DIR (IC1603) CSe / freq report 2
75	P15/D13/INT3_	LOCK	I	PLL LOCK input H: PLL unlock
76	P14/D12	DIR Cd/F1	I	DIR (IC1603) CSd / freq report 1
77	P13/D11	DIR Cc/F0	I	DIR (IC1603) CSc / freq report 0
78	P12/D10	DIR Cb/E2	I	DIR (IC1603) CSb / error condition 2
79	P11/D9	DIR Ca/E1	I	DIR (IC1603) CSa / error condition 1
80	P10/D8	DIR C0_/E0	I	DIR (IC1603) CS0_ / error condition 0
81	P07/D7	DQ7	I/O	Communication data input / output of Flash memory (IC2105)
82	P06/D6	DQ6		
83	P05/D5	DQ5		
84	P04/D4	DQ4		
85	P03/D3	DQ3		
86	P02/D2	DQ2		
87	P01/D1	DQ1		
88	P00/D0	DQ0		
89	P107/AN7/KI3_	CRADPD	O	Center and surround A/D (IC2704 and IC2804) power down L: Power down
90	P106/AN6/KI2_	DSPMUTE	O	Digital filter (IC1703, IC1803, IC1902 and IC2002) mute H: Mute ON
91	P105/AN5/KI1_	CDRST	O	Center DSP (IC1501) reset L: Reset
92	P104/AN4/KI0_	DSP SSR1	O	Communication strobe of front DSP R1 (IC1801) L: Strobe ON
93	P103/AN3	DSP SSL1	O	Communication strobe of front DSP L1 (IC1701) L: Strobe ON
94	P102/AN2	DSP SSR2	O	Communication strobe of front DSP R2 (IC1802) L: Strobe ON
95	P101/AN1	DSP SSL2	O	Communication strobe of front DSP L2 (IC1702) L: Strobe ON
96	AVSS	AVSS	-	VSS
97	P100/AN0	DSP SSCT	O	Communication strobe of center DSP (IC1501) L: Strobe ON
98	VREF	VREF	-	VCC
99	AVCC	AVCC	-	VCC
100	P97/ADTRG_/SIN4	DSP MISO	I	DSP communication data input (←DSP)

■ M38079SFP (DSP ASSY : IC2109)

• System Microcomputer

• Pin Function

No.	Pin Name	I/O	Pin Function
1	P62/AN7	AD	Main unit key input
2	P61/AN6		
3	P60/AN5		
4	P77/AN4	AD	Not used
5	P76/AN3	AD	Encoder
6	P75/AN2	I	
7	P74/AN1	I	
8	P73/Srdy2/AN0	O	DSP MC bus (reset)
9	P72/Sclk2	O	General-purpose bus (clock)
10	P71/Sout2	O	General-purpose bus (dataout)
11	P70/Sin2	I	DSP MC bus (atain)
12	P57/DA2	O	DSP MC bus (cs)
13	P56/DA1	I	DSP MC bus (ready)
14	P55/CNTR1	I	DSP MC bus (interrupt) (request)
15	P54/CNTR0	I	SR signal input (interrupt)
16	P53/INT4	I	Digital filter lock detection (interrupt)
17	P52/INT3	I	DIR lock detection (interrupt)
18	P51/Scmp2/INT2	I	Encoder
19	P50/Tout		
20	P47/Srdy1	O	FL bus UART bus (lat/cts (I))
21	P46/Sclk1		FL bus UART bus (lock/dtr (O))
22	P45/TxD		FL bus UART bus (dataout/txd)
23	P44/RxD	I	FL bus UART bus (datain/rxd)
24	P43/INT1		FL40V line control (dispoft)
25	P42/INT0	I	AC input (interrupt)
26	CNVss		VSS connection (pull-down with 1kΩ to 10kΩ)
27	RESET		Reset input
28	P41/Xcin	O	Output relay (F)
29	P40/Xcout		Output relay (SW)
30	Xin		Oscillator input
31	Xout		Oscillator output
32	Vss	-	GND
33	P27/DB7	O	Data bus of Flash ROM (db7 to db0)
34	P26/DB6		
35	P25/DB5		
36	P24/DB4		
37	P23/DB3		
38	P22/DB2		
39	P21/DB1		
40	P20/DB0		

C-AX10

No.	Pin Name	I/O	Pin Function
41	P17/AD15	O	Address bus of Flash ROM (ad15 to ad2)
42	P16/AD14		
43	P15/AD13		
44	P14/AD12		
45	P13/AD11		
46	P12/AD10		
47	P11/AD9		
48	P10/AD8		
49	P07/AD7		
50	P06/AD6		
51	P05/AD5		
52	P04/AD4		
53	P03/AD3		
54	P02/AD2		
55	P01/AD1	O	Address bus of Flash ROM (ad1 to ad0)
56	P00/AD0		
57	P37/RD	I	Flash ROM (read)
58	P36/WR	O	Flash ROM (write)
59	P35/SYNC	O	Flash ROM (sync)
60	P34/Ckout/φ	O	Flash ROM (clock)
61	P33/RESE Tout	O	Flash ROM (reset)
62	P32/ONW	I	Flash ROM (cnw)
63	P31/RTP7	O	Output relay (C)
64	P30/RTP6	O	Output relay (SL/SR)
65	P87/RTP5	O	FL bus (bk)
66	P86/RTP4	O	Output enable for BU1092 XLOE
67	P85/RTP3	O	DAC VOL (general-purpose bus) fsin
68	P84/RTP2	O	DAC VOL (general-purpose bus) ldac
69	P83/RTP1	O	LED driver (general-purpose bus) strobe
70	P82/RTP0	O	I/O expander (general-purpose bus) strobe
71	P81/DA4/AN12	O	EEPROM backup
72	P80/DA3/AN11	O	EEPROM backup
73	Vcc		Power supply voltage 5.0V
74	ADVref	-	Reference voltage Hi input for A/D converter
75	AVss		Reference voltage Low input for A/D converter
76	P65/DAVref/AN10	AD	Position detect input 1 of Main volume
77	P64/CMPréf/AN9	AD	Position detect input 0 of Main volume
78	P63/CMPin/AN8	AD	DNW SW input
79	CMPout		
80	CMPVcc	-	Not used

■ AK5393VS (FRAD ASSY : IC1105 and CRAD ASSY : IC2704, IC2804)

- Enhanced Dual-bit 108kHz 24-bit 2ch ADC

• Block Diagram

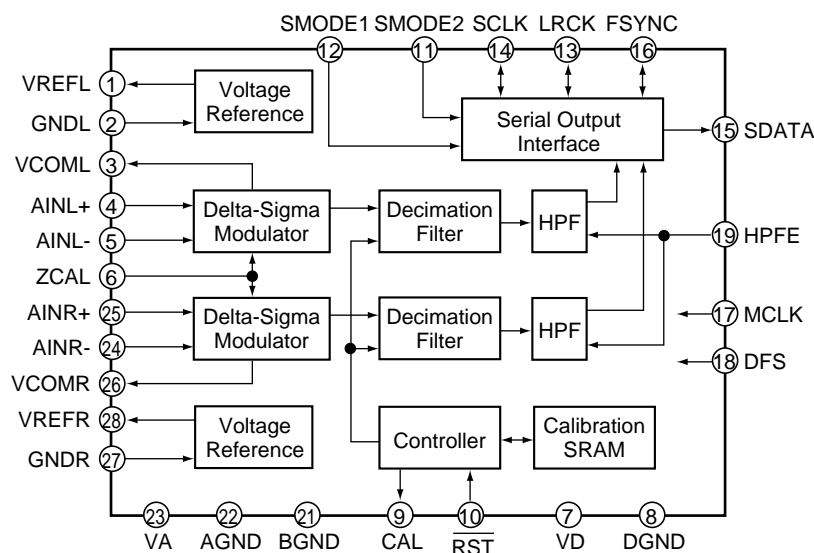

• Pin Function

No.	Pin Name	I/O	Pin Function																				
1	VREF	O	Reference voltage output pin for L ch, 3.75V Connect an 10μF electrolytic capacitor and a 0.1μF ceramic capacitor between this pin and GNDL.																				
2	GNDL	-	Reference ground pin for L ch, 0V																				
3	VCOML	O	Common voltage pin for L ch, 2.75V																				
4	AINL+	I	Analog positive input pin for L ch																				
5	AINL-	I	Analog negative input pin for L ch																				
6	ZCAL	I	Zero calibration Selects the reference signal for using the offset calibration. "L": VCOML, VCOMR , "H": Analog input pin (AIN ±, AINR ±)																				
7	VD	-	Power supply pin for digital section, 3.3V																				
8	DGND	-	Ground pin for digital section																				
9	CAL	O	Calibration status pin Indicates that the during offset calibration at "H". Starts the calibration when RST pin becomes "H", and it beomes "L" after 8704LRCK cycled at DFS=L. It becomes "L" after 17408LRCK cycled at DFS=H.																				
10	RST	I	Reset pin Digital section is power downed at "L". When it becomes "H", the offset calibration is started. Please activate the calibration in power supply injection once.																				
11	SMODE2	I	Serial interface mode select pin MSB first, 2'S complement																				
12	SMODE1																						
<table border="1"> <thead> <tr> <th>SMODE2</th> <th>SMODE1</th> <th>MODE</th> <th>LRCK</th> </tr> </thead> <tbody> <tr> <td>L</td> <td>L</td> <td>Slave mode: Front shorten</td> <td>H/L</td> </tr> <tr> <td>L</td> <td>H</td> <td>Master mode: Quasi I²S</td> <td>H/L</td> </tr> <tr> <td>H</td> <td>L</td> <td>Slave mode: I²S</td> <td>L/H</td> </tr> <tr> <td>H</td> <td>H</td> <td>Master mode: I²S</td> <td>L/H</td> </tr> </tbody> </table>				SMODE2	SMODE1	MODE	LRCK	L	L	Slave mode: Front shorten	H/L	L	H	Master mode: Quasi I ² S	H/L	H	L	Slave mode: I ² S	L/H	H	H	Master mode: I ² S	L/H
SMODE2	SMODE1	MODE	LRCK																				
L	L	Slave mode: Front shorten	H/L																				
L	H	Master mode: Quasi I ² S	H/L																				
H	L	Slave mode: I ² S	L/H																				
H	H	Master mode: I ² S	L/H																				
13	LRCK	I/O	Clock pin of L/R channel selection At SMODE1="H", it becomes "H" when SMODE2="L", and if becomes "L" when SMODE2="H" in the reset.																				

C-AX10

No.	Pin Name	I/O	Pin Function
14	SCLK	I/O	Serial data clock pin Output data outputs 1-bit at falling edge of this pin. Slave mode: clock more than 48fs is necessary Master mode: Output 128fs (DFS="L") and 64fs (DFS="H") clocks At reset= "L"
15	SDATA	O	Serial data output pin MSB first, 2'S complement At reset= "L"
16	FSYNC	I/O	Frame synchronous clock pin Slave mode: SDATA output is enabled at "H" Master mode: 2fs clock output At reset= "L"
17	MCLK	I	Master clock input pin 256fs at DFS="L", 128fs at DFS="H"
18	DFS	I	Double speed sampling mode select pin "L": Normal speed, "H": Double speed
19	HPFE	I	HPF enable pin "L": OFF, "H": ON
20	TEST	I	Test pin Connect to DGND.
21	BGND	-	PCB ground pin, 0V
22	AGND	-	Ground pin for analog section, 0V
23	VA	-	Power supply pin for analog section, 5V
24	AINR-	I	Analog positive input pin for R ch
25	AINR+	I	Analog negative input pin for R ch
26	VCOMR	O	Common voltage pin for R ch, 2.5V
27	GNDR	-	Reference ground pin for R ch, 0V
28	VREFR	O	Reference voltage output pin for R ch, 3.75V Connect an 10 μ F electrolytic capacitor and a 0.1 μ F ceramic capacitor between this pin and GNDR.

7.2.2 Display

■ AAV7065 (DISPLAY ASSY : V2201)

- FL Display

- Pin Assignment

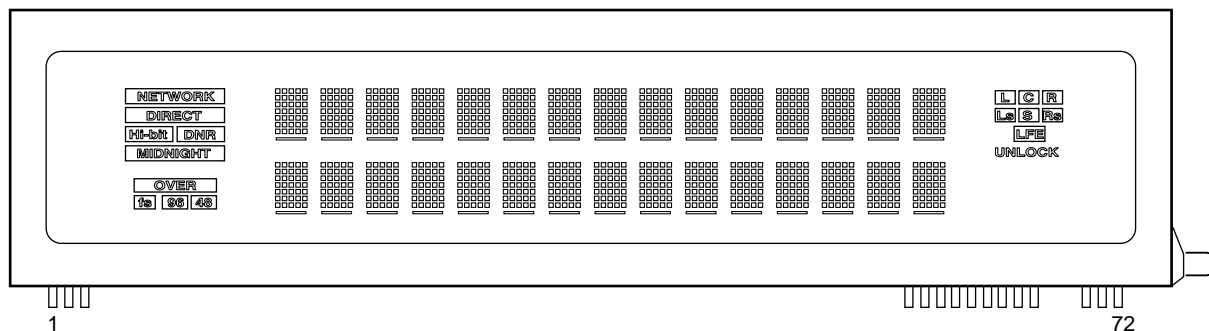

- Grid Assignment

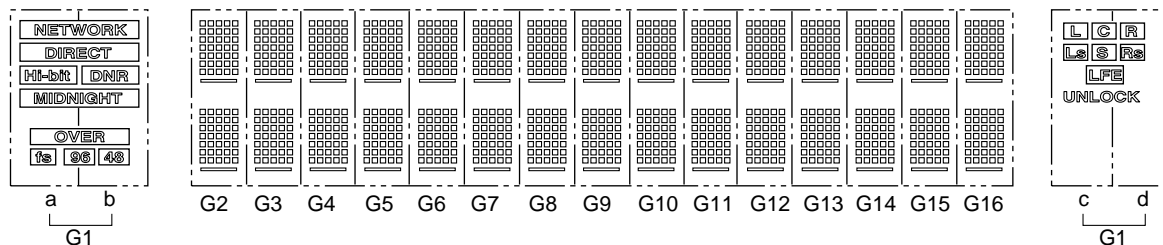

- Pin Connection

Pin No.	1	2	3	4 - 58	59	60	61	62	63	64	65	66	67	68	69	70	71	72
Connection	F1	F1	F1	NP	SI	VDD1	SO	LAT	BK	CLK	VSS	VSS	VDD2	NP	NP	F2	F2	F2

BD system pin out

7.3 REMOTE CONTROL UNIT (CU-C005)

- NOTES:
- Parts marked by "NSP" are generally unavailable because they are not in our Master Spare Parts List.
 - The Δ mark found on some component parts indicates the importance of the safety factor of the part. Therefore, when replacing, be sure to use parts of identical designation.
 - Screws adjacent to \blacktriangledown mark on the product are used for disassembly.

7.3.1 Exploded View and Parts List

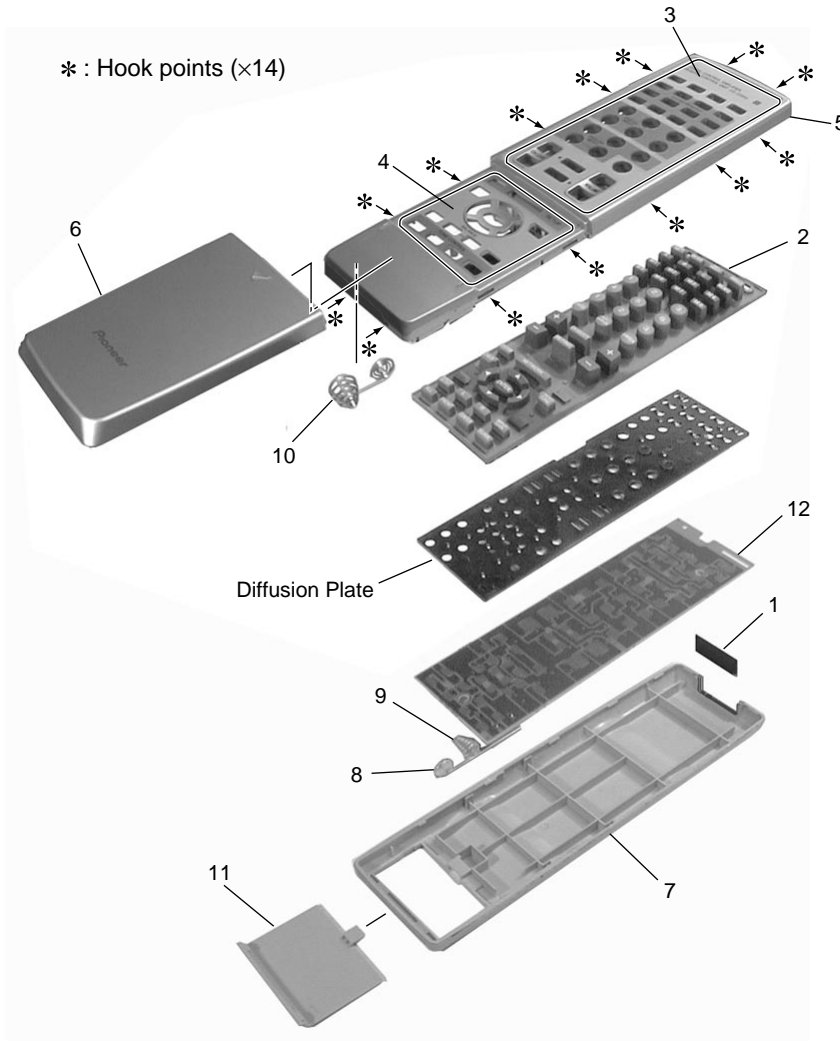

Exploded View Parts List

Mark	No.	Description	Part No.	Mark	No.	Description	Part No.
	1	Filter	AZA7340		8	Terminal A (+)	AZB7141
	2	Rubber Sheet	AZA7372		9	Terminal B (-)	AZB7142
	3	Name Plate A	AZA7373		10	Contact Spring	AZB7143
	4	Name Plate B	AZA7374		11	Battery Cover	AZN7813
	5	Case A	AZN7810		12	PCB for Remote Control Unit (AXD7198)	AZW7256
	6	Slide Case	AZN7812				
	7	Case B	AZN7811				

7.3.2 Schematic Diagram

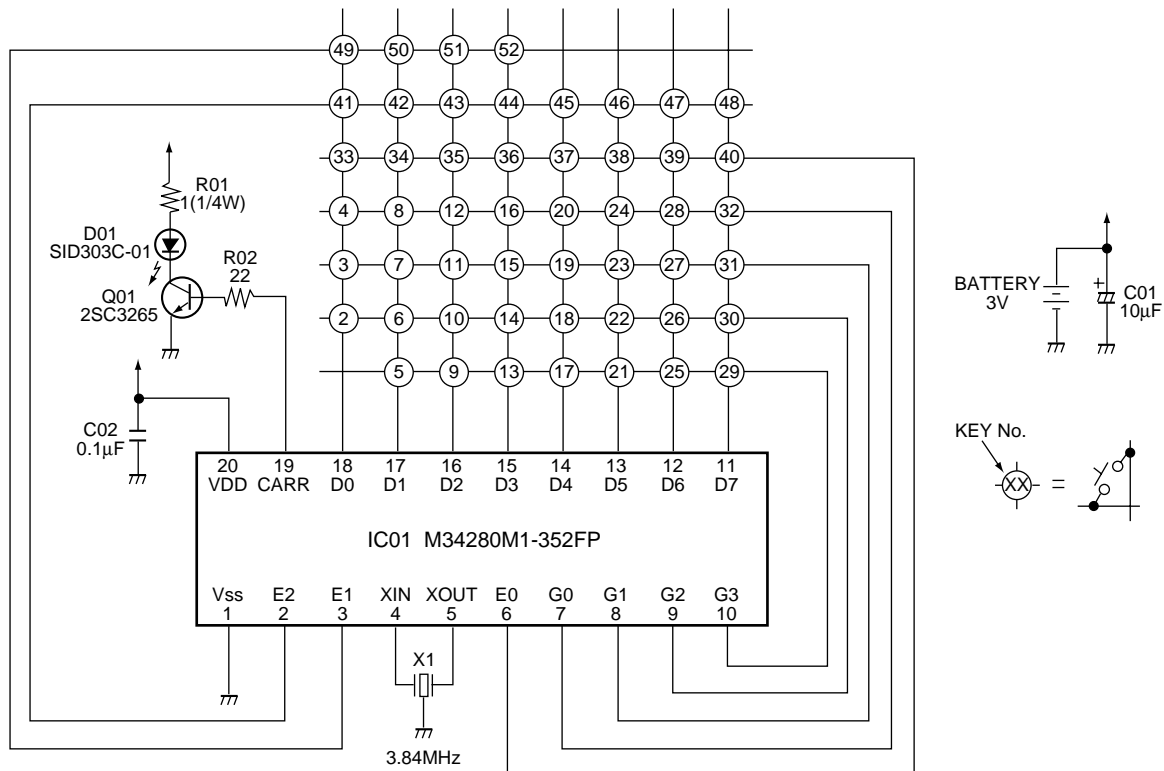

SWITCHES

KEY No.	NAME
2	: DIGITAL NR
3	: Hi-bit
4	: MID-NIGHT
5	: DIRECT
6	: SOUND MEMORY A
7	: SOUND MEMORY B
8	: SOUND MEMORY C
9	: MEMO
10	: M1
11	: M2
12	: M3
13	: M4
14	: M5
15	: M6
16	: M7
17	: M8
18	: DIGITAL IN 1
19	: DIGITAL IN 2
20	: DIGITAL IN 3
21	: DIGITAL IN 4
22	: DIGITAL IN 5
23	: DIGITAL IN 6
24	: ANALOG1
25	: ANALOG2
26	: ANALOG3

KEY No.	NAME
27	: DVD
28	: 2ch/multi ch
29	: DIMMER
30	: CH LEVEL +
31	: CH LEVEL -
32	: CH SELECT
33	: VOL +
34	: VOL -
35	: MUTING
36	: SYSTEM
37	: NETWORK
38	: CHECK
39	: TEST TONE
40	: ▲
41	: ◀
42	: ▶
43	: ▼
44	: ENTER
45	: REMOTE ON/OFF
46	: BALANCE - L
47	: BALANCE - R
48	: INPUT GAIN
49	: ALL
50	: FRONT
51	: CENTER
52	: SURR.

7.3.3 PCB Diagram

PCB for Remote Control Unit (AXD7198)

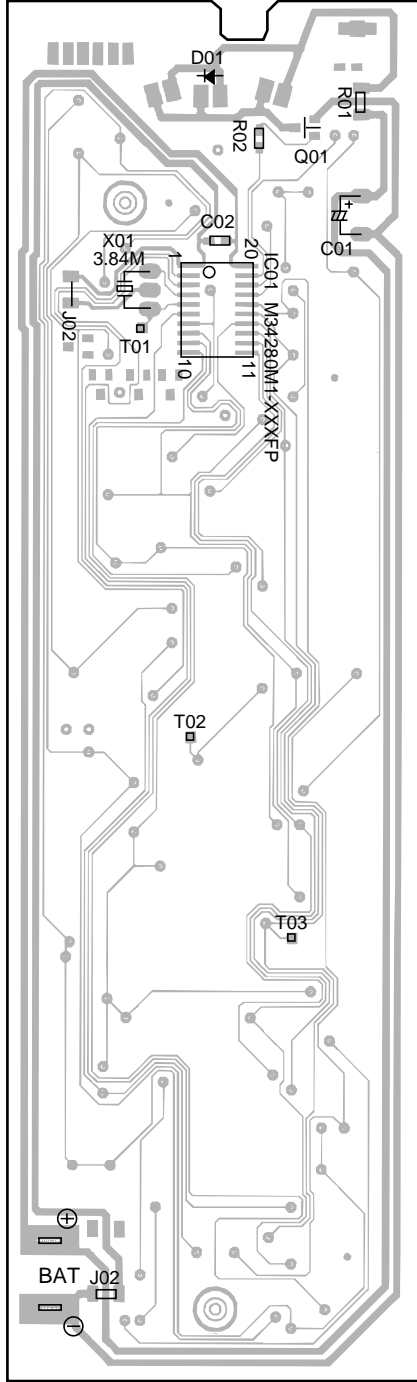

SIDE A

PCB for Remote Control Unit (AXD7198)

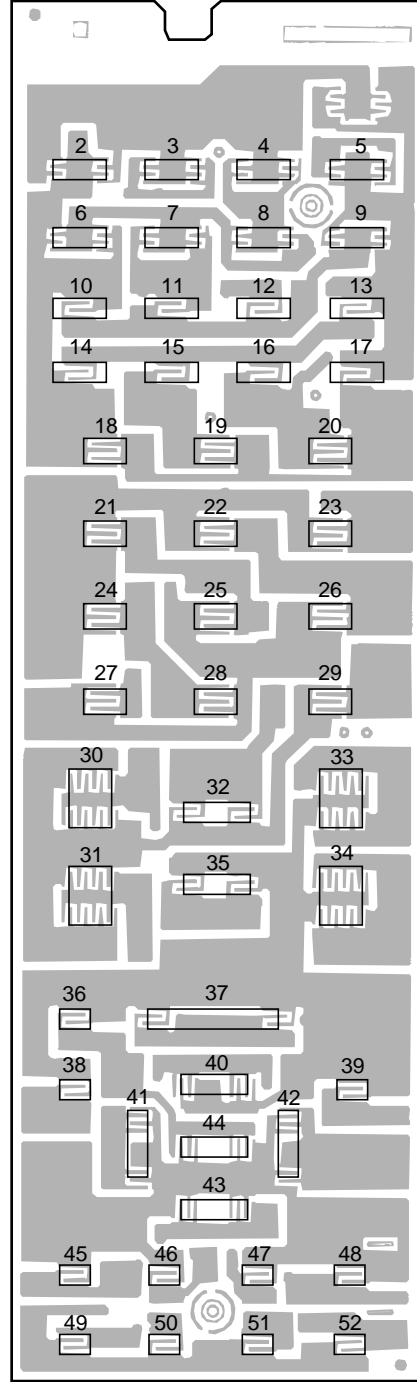

SIDE B

8. PANEL FACILITIES AND SPECIFICATIONS

8.1 PANEL FACILITIES

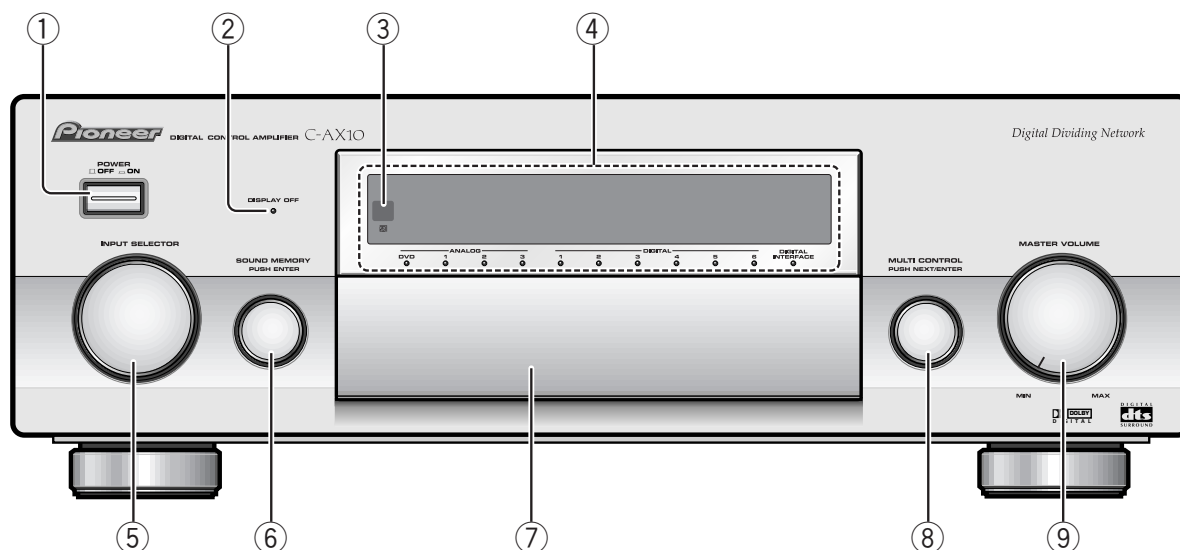

- ① **Power switch (POWER OFF/ON)**
Press the power switch to turn the amplifier on and off.
- ② **DISPLAY OFF indicator**
This indicator turns on when the display is turned off by the Brightness Selection button (⑪).
- ③ **Remote control sensor**
Point the remote control towards this sensor when operating the amplifier.
- ④ **Display**
- ⑤ **INPUT SELECTOR**
This is used to select the input signal.
- ⑥ **SOUND MEMORY jog dial**
You can save and recall up to 16 tone control setting patterns and 8 speaker setup patterns and change the memory number display.
- ⑦ **Front flip-down door**
Press lightly on the bottom of this door to open it.

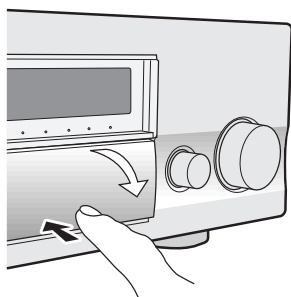

- ⑧ **MULTI CONTROL jog dial**
This jog dial is used to make various settings. Turn the dial to select the setting, and then press to enter (ENTER/NEXT). Refer to the page of the specific function for more details.

- ⑨ **MASTER VOLUME knob**
This knob is used to adjust the volume. Turning this knob adjusts the volume for all channels simultaneously.
- ⑩ **Dolby Digital/DTS button**
When this mode is selected, Dolby Digital, Dolby Pro Logic, or DTS Surround Mode is turned on automatically according to the input signal.
- ⑪ **Brightness Selection button (DIMMER)**
The display brightness can be adjusted to four levels including Display Off. When Display Off is selected, the Display Off indicator (②) turns on.
- ⑫ **DVD Input Selector button (DVD INPUT 2 ch/multi ch)**
When DVD-A input is selected, this button is used to choose either two-channel input or multichannel (six channel) input.
- ⑬ **Sampling Frequency Selector button (fs 96k/48k)**
When an analogue input signal is output from the digital output jack (DIGITAL OUT), this button is used to select whether the sampling frequency (fs) remains unmodified at 96 kHz or drops down to 48 kHz.
- ⑭ **DIGITAL NR button**
This button is used to select the Digital NR function mode.
- ⑮ **Hi-bit button**
This button is used to turn the Hi-bit function on and off.
- ⑯ **MIDNIGHT button**
This button turns the Midnight function on and off.
- ⑰ **DIRECT button**
This button is used to select the Direct function mode.

When the front flip-down door is opened

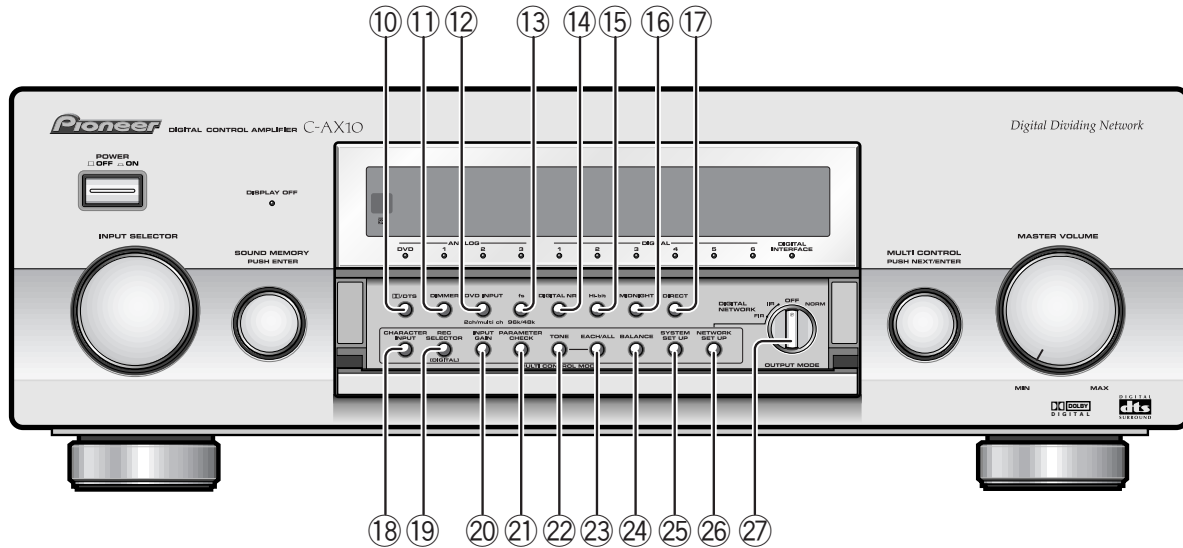

18 CHARACTER INPUT button*

This button is used to enter the Character Input mode for changing the input signal or sound memory setting to a user-selected name.

19 Digital REC Selector button (REC SELECTOR [DIGITAL])*

This button is used to enter the mode for selecting the REC OUT signal that is output from the digital output jack.

20 INPUT GAIN button*

This button is used to enter the mode for adjusting the analogue input and digital input gain.

21 PARAMETER CHECK button*

This button is used to enter the mode for checking the current settings.

22 Tone Control button (TONE)*

This button is used to enter Tone Control mode.

23 Tone Control Channel button (EACH/ALL)*

This button is used to switch between EACH mode and ALL mode.

- EACH mode : The front, centre, and surround channels can each be set individually.
- ALL mode : The front, centre, and surround channels are set to the same settings.

24 Balance Control button (BALANCE)*

This button is used to enter the mode for adjusting the balance of the front left and right channels.

25 SYSTEM SET UP button*

This button is used to enter System Setup mode for speaker setup or selecting modes.

26 NETWORK SET UP button*

This button is used to enter Network Setup mode when the OUTPUT MODE selector (27) is set to Digital Network FIR mode or Digital Network IIR mode.

27 OUTPUT MODE selector

This selector is used to set to one of the following four modes.

- Digital Network FIR mode
- Digital Network IIR mode
- Normal mode
- OFF (Output off)



* After pressing the buttons in 18 to 26, use the MULTI CONTROL jog dial 8 to make the settings and adjustments.

Remote Control Unit (CU-C005)

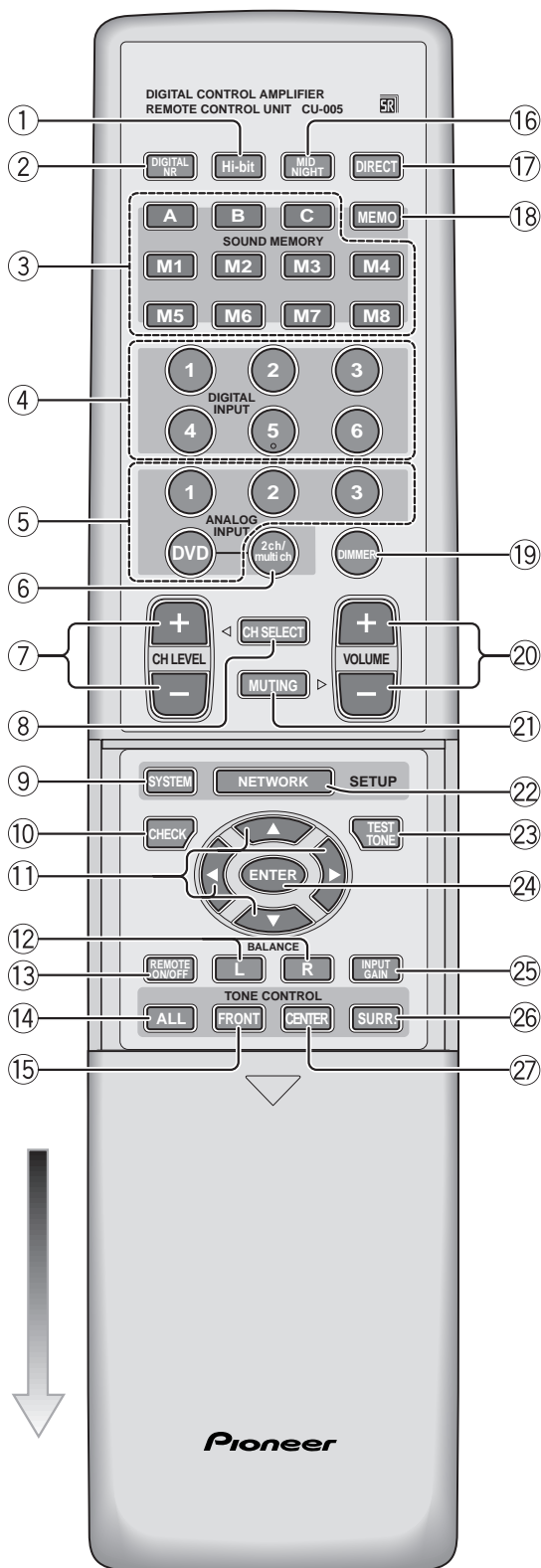

This figure shows the remote control when the slide cover has been pulled down.

To open the slide cover, press on the ▽ mark on the cover and the indentation on the back of the remote control, and then pull the cover down slightly so that the lock releases with a clicking sound.

- ① **Hi-bit button**
This button is used to turn the Hi-bit function on and off.
- ② **DIGITAL NR button**
This button is used to select the Digital NR function mode.
- ③ **SOUND MEMORY buttons**
These buttons are used to save and recall up to 16 tone control setting patterns and 8 speaker setup patterns. The three buttons A, B, and C can be selected within the eight buttons M1 to M8.
- ④ **Digital Input selector (DIGITAL INPUT 1 to 6)**

These buttons are used to select the digital input signal.
- ⑤ **Analogue Input selector (ANALOG INPUT 1 to 3, DVD)**
These buttons are used to select the analogue input signal.
- ⑥ **2ch/multi ch (DOLBY/DTS) button**
When DVD-A input is selected, this button is used to select two-channel input, multichannel (six channel) input, or multichannel output after conversion of the two-channel signal to Dolby Pro Logic.
If an input other than DVD-A input is selected, OFF (2ch) and ON (multi) for Dolby Digital, Dolby Pro Logic, DTS, and Surround Mode are set according to the signal that is input.
- ⑦ **Channel Level buttons (CHANNEL LEVEL +, -)**
- ⑧ **Channel Select buttons (CH SELECT)**
To adjust the channel level, use this button to choose the channel, and then use the CHANNEL LEVEL + and - buttons (⑦) to adjust the level.
- ⑨ **SYSTEM SET UP button**
This button is used to enter System Setup mode for speaker setup or selecting modes.
- ⑩ **CHECK button**
This button is used to enter the mode for checking the current settings.
- ⑪ **◀/▶/▲/▼ buttons**
These buttons are used to make selections and settings.
- ⑫ **Balance Control buttons (BALANCE L, R)**

These buttons are used to adjust the balance of the front left and right channels.
- ⑬ **REMOTE ON/OFF button**
This button is used to select whether the amplifier can receive operations from the remote control (ON) or not (OFF). Set to OFF when more than one Pioneer amplifier is operating at the same time. When set to OFF, the amplifier can be operated only from the amplifier unit.

⑭ **All Tone Control button (ALL)**

This button is used to perform total tone control at the same settings for the front, centre, and surround channels.

⑮ **Front Tone Control button (FRONT)**

This button is used to perform tone control for the front channels.

⑯ **MIDNIGHT button**

This button turns the Midnight function on and off.

⑰ **DIRECT button**

This button is used to select the Direct function mode.

⑱ **Memory button (MEMO)**

This button is used when saving the sound memory settings.

⑲ **Brightness Selection button (DIMMER)**

The display brightness can be adjusted to four levels including Display Off.

⑳ **Master Volume buttons (VOLUME +, -)**

These buttons are used to adjust the volume.

㉑ **Muting button (MUTING)**

This button is used to temporarily turn off the sound.

㉒ **NETWORK SET UP button**

This button is used to enter Network Setup mode when the Output mode is set to Digital Network (IIR or FIR).

㉓ **TEST TONE button**

This button is used to adjust the level using the test tone.

㉔ **ENTER button**

This button is used to enter selections and make settings.

㉕ **INPUT GAIN button**

This button is used to enter the mode for adjusting the analogue input and digital input gain.

㉖ **Surround Tone Control button (SURR.)**

This button is used to perform tone control for the surround channels.

㉗ **Centre Tone Control button (CENTER)**

This button is used to perform tone control for the centre channel.

Operating Range of the Remote Control

When using the remote control to operate the amplifier, point the remote control towards the remote control sensor on the front panel.

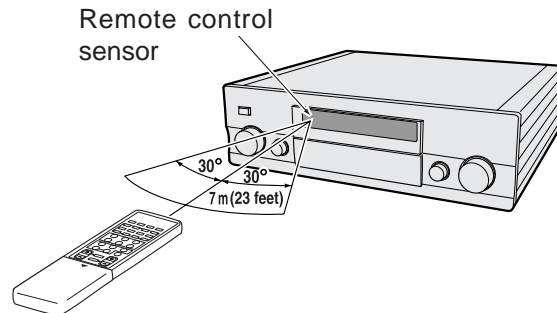

- The remote control may not operate when there are objects between the remote control and amplifier or when the remote control is used at a wide angle from the sensor.
- The amplifier may malfunction if sunlight, fluorescent lights, or other strong lighting shines directly on the remote control sensor.
- The amplifier may malfunction if it is used near devices that emit infrared beams or when other remote control devices that use infrared beams are used. Conversely, this remote control can also cause other similar devices to malfunction when used in the same area.

■ Display

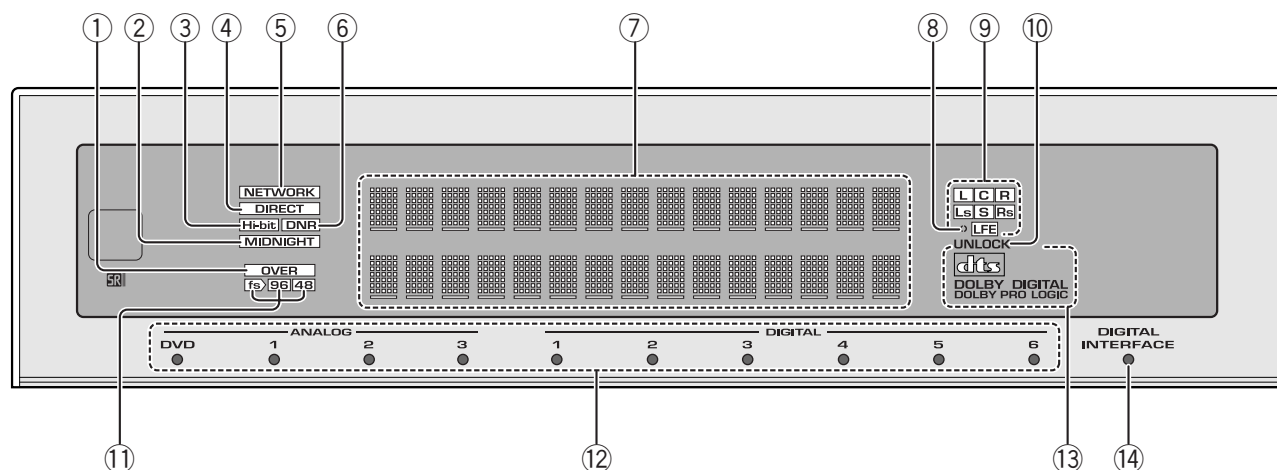

- ① **OVER indicator**
This indicator turns on when the input level of the analogue signal is too high or when the signal level during the internal DSP operation is too high. Adjust the input gain when this indicator turns on.
- ② **MIDNIGHT indicator**
This indicator turns on when the Midnight function is on.
- ③ **Hi-bit indicator**
This indicator turns on when the Hi-bit function is on.
- ④ **DIRECT indicator**
This indicator turns on when the Direct function is on.
- ⑤ **NETWORK indicator**
This indicator turns on when the amplifier is set to Digital Network (Channel Divider) mode.
- ⑥ **DNR indicator**
This indicator turns on when the digital NR function is on.
- ⑦ **Character display**
This display shows alphanumeric characters and symbols to convey various types of information.
- ⑧ **LFE indicator**
The LFE indicator turns on when LFEs (low frequency effect) are contained in the playback software. When LFE signals are actually played back (LFE signals do not exist in the entire sound track), the ● mark next to the LFE indicator turns on.
- ⑨ **Program Format indicator**
The channel indicators corresponding to the input signals turn on when a PDIF connection is made or when a Dolby Digital or DTS signal is input.
 - L: Front left channel
 - C: Centre channel
 - R: Front right channel
 - LS: Surround left channel
 - S: Surround channel (monaural)
 - RS: Surround right channel
 - LFE: LFE signal
- ⑩ **UNLOCK indicator**
This indicator turns on when the digital input signal is cut off.
- ⑪ **Sampling Frequency indicator**
This indicator displays the sampling frequency (fs) of the digital REC OUT signal selected in the section "Selecting the Digital Output Sampling Frequency during Analogue Input".
 - 96 : 96 kHz
 - 48 : 48 kHz
- ⑫ **Input indicator**
The indicator for the input signal selected by the INPUT SELECTOR turns on.
- ⑬ **Surround/DTS Mode indicator**
 - DTS: This indicator turns on when DTS signals are input while Surround/DTS mode is on.
 - DOLBY DIGITAL: This indicator turns on when playing back Dolby digital signals while Dolby Surround/ mode is on. However, DOLBY PRO LOGIC turns on when playing back Dolby Digital signals recorded in two channels.
 - DOLBY PRO LOGIC: This indicator turns on when playing back a two-channel source in DOLBY PRO LOGIC while Dolby Surround/DTS button is on.
- ⑭ **DIGITAL INTERFACE indicator**
This indicator turns on when using the INPUT SELECTOR to choose the input signals when a PDIF connection is made.

REAR PANEL

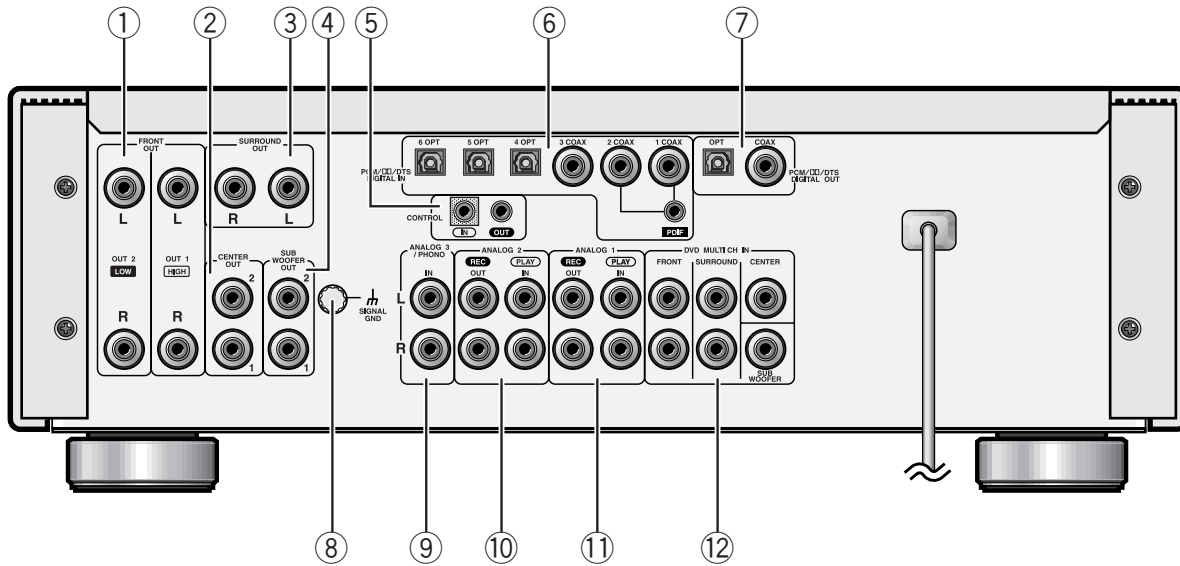

① Front output jacks (FRONT OUT)

These are the front channel output jacks. In Normal mode, OUT 1 and OUT 2 have the same output. In Network mode, OUT 1 has high range (HIGH) output and OUT 2 has low range (LOW) output.

② Centre output jacks (CENTER OUT)

These are the centre channel output jacks during multichannel (six channel) output. Both 1 and 2 have the same output.

③ Surround output jacks (SURROUND OUT)

These are the surround channel output jacks during multichannel (six channel) output.

④ Subwoofer output jacks (SUB WOOFER OUT)

These are the subwoofer channel output jacks during multichannel (six channel) output. Both 1 and 2 have the same output.

⑤ Control input/output jacks (CONTROL IN, OUT)

These jacks are used for controlling multiple Pioneer devices having the  mark from the remote control sensor of a single device.

⑥ Digital input jacks (PCM/DSD/DTS DIGITAL IN)

Jacks 1 to 3 are for coaxial cables (COAX) and jacks 4 to 6 are for fiber-optic cables (OPT). In a PDIF connection, the PDIF jack, 1 COAX jack and 2 COAX jack are used. For details, see page 47.

⑦ Digital output jacks (PCM/DSD/DTS DIGITAL OUT)

These output jacks are for a coaxial cable (COAX) and a fiber-optic cable (OPT).

⑧ Signal ground terminal (SIGNAL GND)

Use this terminal when using an analogue record player or other device where a signal ground is required.

CAUTION

This terminal is provided to reduce noise. It is not a safety ground.

⑨ ANALOG 3/PHONO input jacks

These jacks are used to select line input or phono input. See page 45 for the selection method.

⑩ ANALOG 2 input/output jacks

These jacks are used for making analogue connections to recording or playback devices through the line input/output jacks.

⑪ ANALOG 1 input/output jacks

These jacks are used for making analogue connections to recording or playback devices through the line input/output jacks.

⑫ DVD multichannel input jacks (DVD MULTI CH IN)

These jacks are used to connect to a DVD-Audio player having 6-channel output or a DVD player or other device having 5.1 channel output.

8.2 SPECIFICATIONS

■ Digital preamplifier

Number of quantizing bits

Digital input	16 – 24 bits/linear
Analogue input	24 bits/linear

Sampling frequency

Digital input	32 kHz, 44.1 kHz, 48 kHz, 88.2 kHz, (automatic 96 kHz, 176.4 kHz, 192 kHz detection) (176.4 kHz and 192 kHz are possible only when using PDIF connections.)
Analogue input	96 kHz

Frequency characteristics (Direct function is on)

Digital input	5 Hz – 44 kHz (Sampling frequency: 96 kHz)
Analogue input LINE	5 Hz – 44 kHz
PHONO (MM)	20 Hz – 20 kHz \pm 0.3 dB

S/N ratio (Normal, 2-channel mode)

Digital input	118 dB min. (acoustic correction)
Analogue input	
LINE	115 dB min. (acoustic correction)
PHONO(MM)	84 dB min. (IHF A network, short circuit) (when 6 mV is input)

Dynamic range (Direct function is on, Normal, 2-channel mode)

Digital input	110 dB min.
Analogue input	108 dB min. (except for PHONO)

Total harmonic distortion

(Direct function is on, Normal, 2-channel mode)

Digital input	0.0010% max.
Analogue input	0.0012% max. (except for PHONO)

Channel separation (Normal and 2-channel mode)

Digital input	115 dB min. (20 kHz)
---------------------	----------------------

Tone control

.....	\pm 6 dB 0.5 dB-steps
BASS	150 Hz, 300 Hz
MID	400 Hz, 500 Hz, 630 Hz, 800 Hz, 1.0 kHz, 1.2 kHz
TREBLE	3 kHz, 10 kHz

Analogue maximum allowable input (Input gain: –6 dB)

LINE	5 V
PHONO (MM)	45 mV (1 kHz)

■ Input/output jacks

Analogue input jack RCA 4-line (Input impedance: 50 k Ω)
..... (one of these lines supports multichannel input)

Analogue output jacks

Preout	
[Output impedance: 100 Ω (max.)]	Front: 2 RCA lines
.....	Surround: 1 RCA line
.....	Centre: 2 RCA lines
.....	Subwoofer: 2 RCA lines
.....	REC out: 2 RCA lines
.....	(Output impedance: 1 k Ω)

Digital input jacks

Coaxial 3-line:	0.5 Vp-p (Input impedance: 75 Ω)
Optical 3-line	

Digital output jacks

Coaxial 1-line:	0.5 Vp-p (Output impedance: 75 Ω)
Optical 1-line	

- The signal format during PDIF mode is Pioneer's own custom format, and it does not conform to the IEC60958 standards.

C-AX10

■ Power supply/miscellaneous

Supply voltage	AC 230 V, 50/60Hz (For European model)
.....	AC 120V, 60Hz (For American model)
Power consumption	52 W
Dimensions	440 (W) × 150 (H) × 410 (D) mm
.....	17 ⁵ / ₁₆ (W) × 5 ⁷ / ₈ (H) × 16 ¹ / ₈ (D) in.
Weight	22.2 kg/48.9 lbs(without package)

■ Accessories

Operating instructions	1
Warranty	1
Remote control	1
AA batteries (R6P)	2
PDIF connection cable (stereo mini-plug)	1

* The audio characteristics are values measured at a sampling frequency of 96 kHz and 24 bits.

- The above specifications and product appearance are subject to change without notice for incorporating product improvements.

■ Accessories

- PDIF Connection Cable (ADE1087)

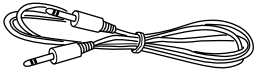

- Remote control unit (CU-C005) (AXD7198)

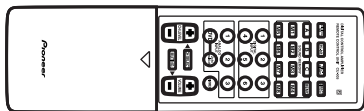

- Dry Cell Batteries (R6P)

