

Service Manual

Pioneer



ORDER NO.
RRV2027

COMPACT DISC PLAYER

CDJ-100S

THIS MANUAL IS APPLICABLE TO THE FOLLOWING MODEL(S) AND TYPE(S).

Type	Model	Power Requirement	The voltage can be converted by the following method.
	CDJ-100S		
KUC	○	AC120V	_____
RL	○	AC110-120V/220-240V	With the voltage selector
WY	○	AC220-240V	_____

CONTENTS

1. SAFETY INFORMATION	2	7. GENERAL INFORMATION	39
2. EXPLODED VIEWS AND PARTS LIST	4	7.1 PARTS	39
3. SCHEMATIC DIAGRAM	10	7.1.1 IC	39
4. PCB CONNECTION DIAGRAM	24	7.1.2 DISPLAY	41
5. PCB PARTS LIST	30	7.2 DIAGNOSIS	42
6. ADJUSTMENT	33	7.2.1 ERROR DISPLAY	42
		7.2.2 DISASSEMBLY	42
		7.3 BLOCK DIAGRAM	46
		8. PANEL FACILITIES AND SPECIFICATIONS	47

PIONEER ELECTRONIC CORPORATION 4-1, Meguro 1-Chome, Meguro-ku, Tokyo 153-8654, Japan
PIONEER ELECTRONICS SERVICE, INC. P.O. Box 1760, Long Beach, CA 90801-1760, U.S.A.
PIONEER ELECTRONIC (EUROPE) N.V. Haven 1087, Keetberglaan 1, 9120 Melsele, Belgium
PIONEER ELECTRONICS ASIACENTRE PTE. LTD. 501 Orchard Road, #10-00 Wheelock Place, Singapore 238880
 © PIONEER ELECTRONIC CORPORATION 1998

1. SAFETY INFORMATION

This service manual is intended for qualified service technicians; it is not meant for the casual do-it-yourselfer. Qualified technicians have the necessary test equipment and tools, and have been trained to properly and safely repair complex products such as those covered by this manual. Improperly performed repairs can adversely affect the safety and reliability of the product and may void the warranty. If you are not qualified to perform the repair of this product properly and safely, you should not risk trying to do so and refer the repair to a qualified service technician.



WARNING

This product contains lead in solder and certain electrical parts contain chemicals which are known to the state of California to cause cancer, birth defects or other reproductive harm.

Health & Safety Code Section 25249.6 – Proposition 65



NOTICE

(FOR CANADIAN MODEL ONLY)

Fuse symbols  (fast operating fuse) and/or  (slow operating fuse) on PCB indicate that replacement parts must be of identical designation.

REMARQUE

(POUR MODÈLE CANADIEN SEULEMENT)

Les symboles de fusible  (fusible de type rapide) et/ou  (fusible de type lent) sur CCI indiquent que les pièces de remplacement doivent avoir la même désignation.

(FOR USA MODEL ONLY)

1. SAFETY PRECAUTIONS

The following check should be performed for the continued protection of the customer and service technician.

LEAKAGE CURRENT CHECK

Measure leakage current to a known earth ground (water pipe, conduit, etc.) by connecting a leakage current tester such as Simpson Model 229-2 or equivalent between the earth ground and all exposed metal parts of the appliance (input/output terminals, screwheads, metal overlays, control shaft, etc.). Plug the AC line cord of the appliance directly into a 120V AC 60 Hz outlet and turn the AC power switch on. Any current measured must not exceed 0.5 mA.

ANY MEASUREMENTS NOT WITHIN THE LIMITS OUTLINED ABOVE ARE INDICATIVE OF A POTENTIAL SHOCK HAZARD AND MUST BE CORRECTED BEFORE RETURNING THE APPLIANCE TO THE CUSTOMER.

2. PRODUCT SAFETY NOTICE

Many electrical and mechanical parts in the appliance have special safety related characteristics. These are often not evident from visual inspection nor the protection afforded by them necessarily can be obtained by using replacement components rated for voltage, wattage, etc. Replacement parts which have these special safety characteristics are identified in this Service Manual.

Electrical components having such features are identified by marking with a Δ on the schematics and on the parts list in this Service Manual.

The use of a substitute replacement component which does not have the same safety characteristics as the PIONEER recommended replacement one, shown in the parts list in this Service Manual, may create shock, fire, or other hazards.

Product Safety is continuously under review and new instructions are issued from time to time. For the latest information, always consult the current PIONEER Service Manual. A subscription to, or additional copies of, PIONEER Service Manual may be obtained at a nominal charge from PIONEER.

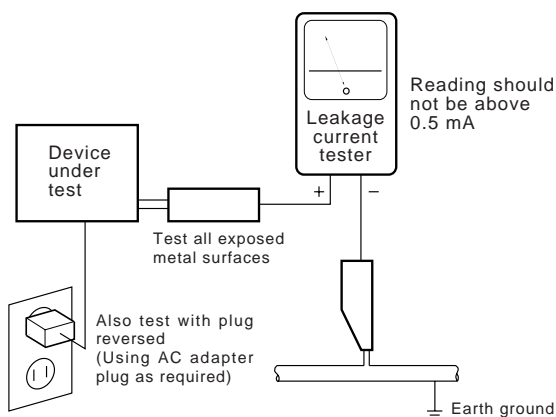

— IMPORTANT —

THIS PIONEER APPARATUS CONTAINS LASER OF CLASS 1. SERVICING OPERATION OF THE APPARATUS SHOULD BE DONE BY A SPECIALLY INSTRUCTED PERSON.

— LASER DIODE CHARACTERISTICS —

MAXIMUM OUTPUT POWER: 5 mw
WAVELENGTH: 780 – 785 nm

LABEL CHECK (for WY type)

ADVARSEL

USYNLIG LASERSTRÅLING VED ÅBNING NÅR SIKKERHED SAF-BRYDERE ER UDE AF FUNKTION.
UNOGÅ UDSÆTTELSE FOR STRÅLING.

VORSICHT!

UNSICHTBARE LASER-STRÅHLUNG TRITTS AUS, WENN DECKEL (ODER KLAPPE) GEÖFFNET IST! NICHT DEM STRAHL AUSSETZEN!
VRW1094

VARO!

Avattaessa ja suojalukitus ohitettaessa olet alttiina näkymättömälle lasersäteilylle. Älä katso säteeseen.

WARNING!

Osynlig laserstrålning när denna del är öppnad och spärren är urkopplad. Betrakta ej strålen.
VRW1297-A

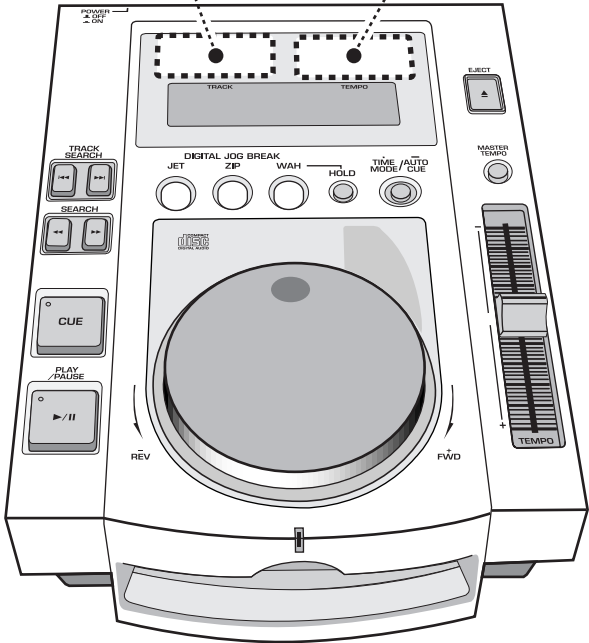

Additional Laser Caution

- 1. Laser Interlock Mechanism**

The position of the switch (S1) for detecting loading completion is detected by the system microprocessor, and the design prevents laser diode oscillation when the switch is not in LPS1 terminal side (when the mechanism is not clamped and LPS1 signal is high level.) Thus, the interlock will no longer function if the switch is deliberately set to LPS1 terminal side. (if LPS1 signal is low level).

In the test mode* the interlock mechanism will not function. Laser diode oscillation will continue, if pin 33 of CXA1782CQ (IC101) on the MOTHER BOARD ASSY is connected to GND, or pin 43 of IC701 (LDON) is connected to low level (ON), or else the terminals of Q101 are shorted to each other (fault condition).
- 2. When the cover is opened, close viewing of the objective lens with the naked eye will cause exposure to a Class 1 laser beam.**

* : Refer to page 34.

2. EXPLODED VIEWS AND PARTS LIST

- NOTES :
- Parts marked by “NSP” are generally unavailable because they are not in our Master Spare Parts List.
 - The \triangle mark found on some component parts indicates the importance of the safety factor of the part. Therefore, when replacing, be sure to use parts of identical designation.
 - Screw adjacent to \blacktriangledown mark on the product are used for disassembly.

2.1 PACKING

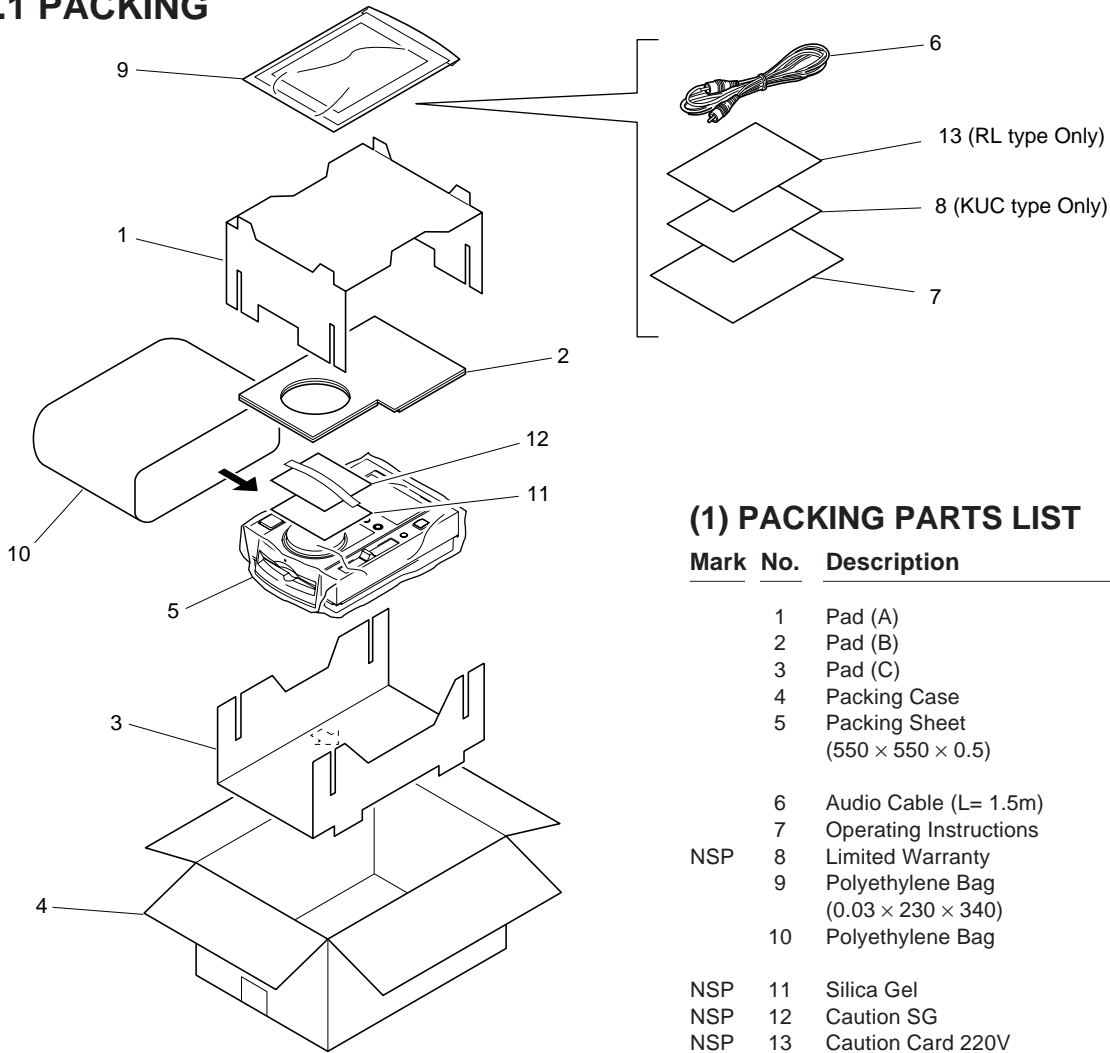

(1) PACKING PARTS LIST

Mark	No.	Description	Part No.
	1	Pad (A)	DHA1411
	2	Pad (B)	DHA1412
	3	Pad (C)	DHA1413
	4	Packing Case	See Contrast table (2)
	5	Packing Sheet (550 × 550 × 0.5)	Z23-026
	6	Audio Cable (L= 1.5m)	VDE1033
	7	Operating Instructions	See Contrast table (2)
NSP	8	Limited Warranty	See Contrast table (2)
	9	Polyethylene Bag (0.03 × 230 × 340)	Z21-038
	10	Polyethylene Bag	DHL1106
NSP	11	Silica Gel	AEN7001
NSP	12	Caution SG	DRM1199
NSP	13	Caution Card 220V	See Contrast table (2)

(2) CONTRAST TABLE

CDJ-100S/KUC, RL and WY are constructed the same except for the following:

Mark	No.	Symbol and Description	Part No.			Remarks
			KUC type	RL type	WY type	
	4	Packing Case	DHG1852	DHG1851	DHG1850	
	7	Operating Instructions (English)	DRB1232	Not used	Not used	
	7	Operating Instructions (English/Spanish/Chinese)	Not used	DRB1229	Not used	
	7	Operating Instructions (English/French/German/Italian/ Dutch/Spanish)	Not used	Not used	DRB1227	
NSP	8	Limited Warranty	DRY1177	Not used	Not used	
NSP	13	Caution Card 220V	Not used	ARR7003	Not used	

2.2 EXTERIOR (1/2)

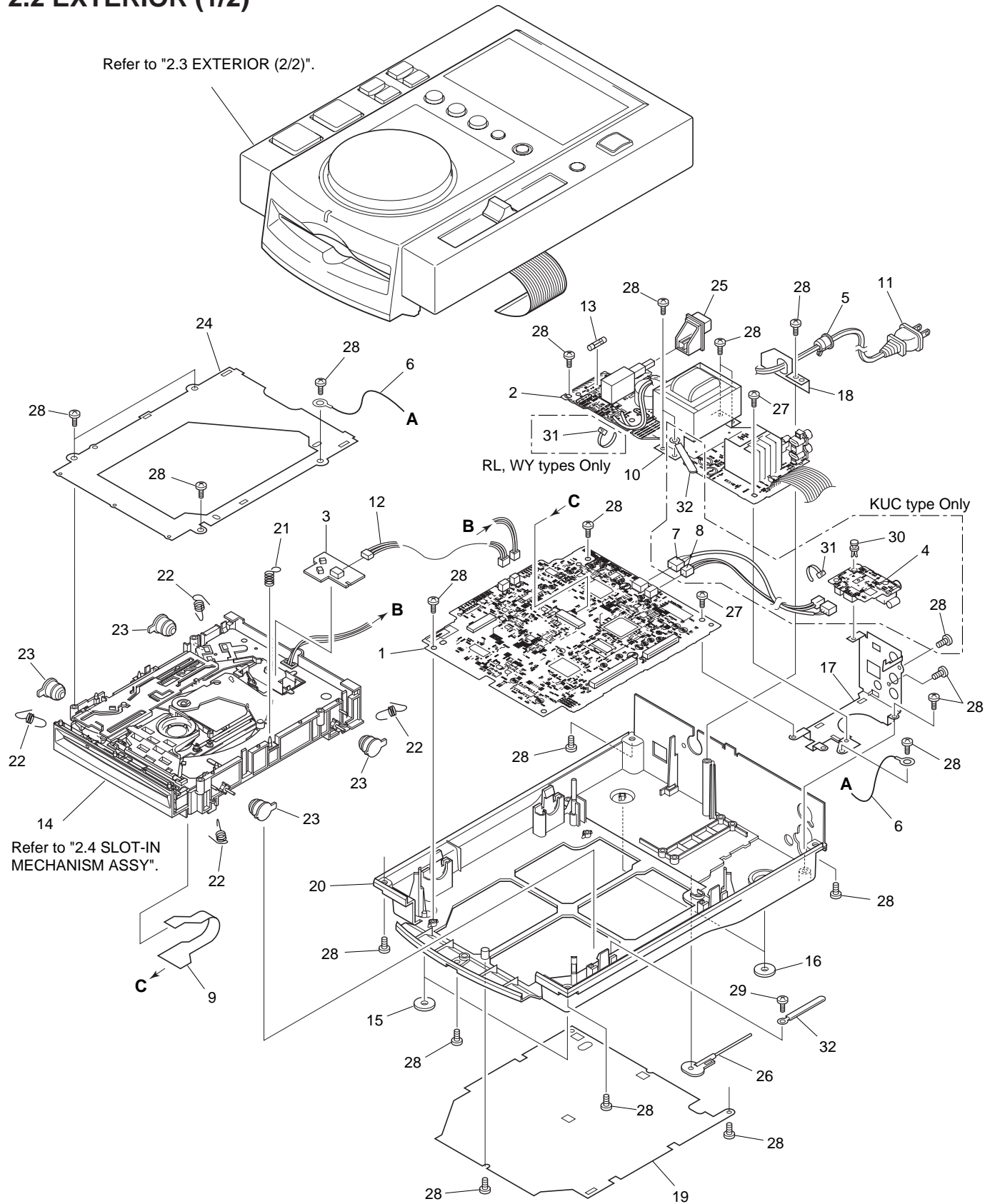

(1) EXTERIOR (1/2) PARTS LIST

Mark	No.	Description	Part No.	Mark	No.	Description	Part No.
	1	MOTHER BOARD ASSY	See Contrast table (2)		26	Push Rod	DEX1008
	2	TRANS BOARD ASSY	See Contrast table (2)		27	Screw	BBZ30P080FMC
NSP	3	SL MECHA BOARD ASSY	DWS1294		28	Screw	BPZ30P080FZK
NSP	4	DIGITAL OUT BOARD ASSY	See Contrast table (2)		29	Screw	BPZ30P140FMC
	5	Strain Relief	See Contrast table (2)		30	Nylon Rivet (3 × 4.5)	See Contrast table (2)
	6	Earth Lead Unit/300V	DDF1010		31	Binder	ZCA-SKB90BK
	7	Connector Assy	See Contrast table (2)	NSP	32	Binder	Z09-061
	8	Connector Assy (2P)	See Contrast table (2)				
	9	S Flex	DNP1748				
△	10	Power Transformer	See Contrast table (2)				
△	11	AC Power Cord	See Contrast table (2)				
△	12	Connector Assy	PF03PP-B30				
△	13	Fuse (FU1)	See Contrast table (2)				
NSP	14	Slot-in Mechanism Assy	DXA1845				
	15	Insulator	DEC2235				
	16	Insulator MO	DEC2250				
	17	Earth Plate	DNF1588				
	18	Cable Stay	DNF1589				
	19	Bottom Plate	See Contrast table (2)				
NSP	20	Chassis	See Contrast table (2)				
	21	Earth Spring	DBH1398				
	22	Float Spring	DBH1428				
	23	Damper	DEC2236				
	24	Mecha Holder	DNH2339				
	25	Power Knob	DAC1895				

(2) CONTRAST TABLE

CDJ-100S/KUC, RL and WY are constructed the same except for the following:

Mark	No.	Symbol and Description	Part No.			Remarks
			KUC type	RL type	WY type	
NSP	1	MOTHER BOARD Assy	DWM2078	DWM2079	DWM2079	
	2	TRANS BOARD Assy	DWR1298	DWR1301	DWR1300	
	4	DIGITAL OUT BOARD Assy	DWZ1082	Not used	Not used	
	5	Strain Relief	CM-22C	CM-22B	CM-22B	
	7	Connector Assy	DKP3408	Not used	Not used	
	8	Connector Assy (2P)	DKP3409	Not used	Not used	
	△	10	Power Transformer (AC120V)	DTT1148	Not used	
△	10	Power Transformer	Not used	DTT1149	Not used	
△	10	(AC110-120V/220-240V) Power Transformer (AC220-240V)	Not used	Not used	DTT1150	
△	11	AC Power Cord	PDG1063	PDG1003	PDG1003	
△	13	Fuse (FU1)	VEK1009	AEK1051	AEK1051	
	19	Bottom Plate	DNH2341	DNH2338	DNH2338	
NSP	20	Chassis	DNK3562	DNK3561	DNK3553	
	30	Nylon Rivet (3 × 4.5)	RBM-003	Not used	Not used	

2.3 EXTERIOR (2/2)

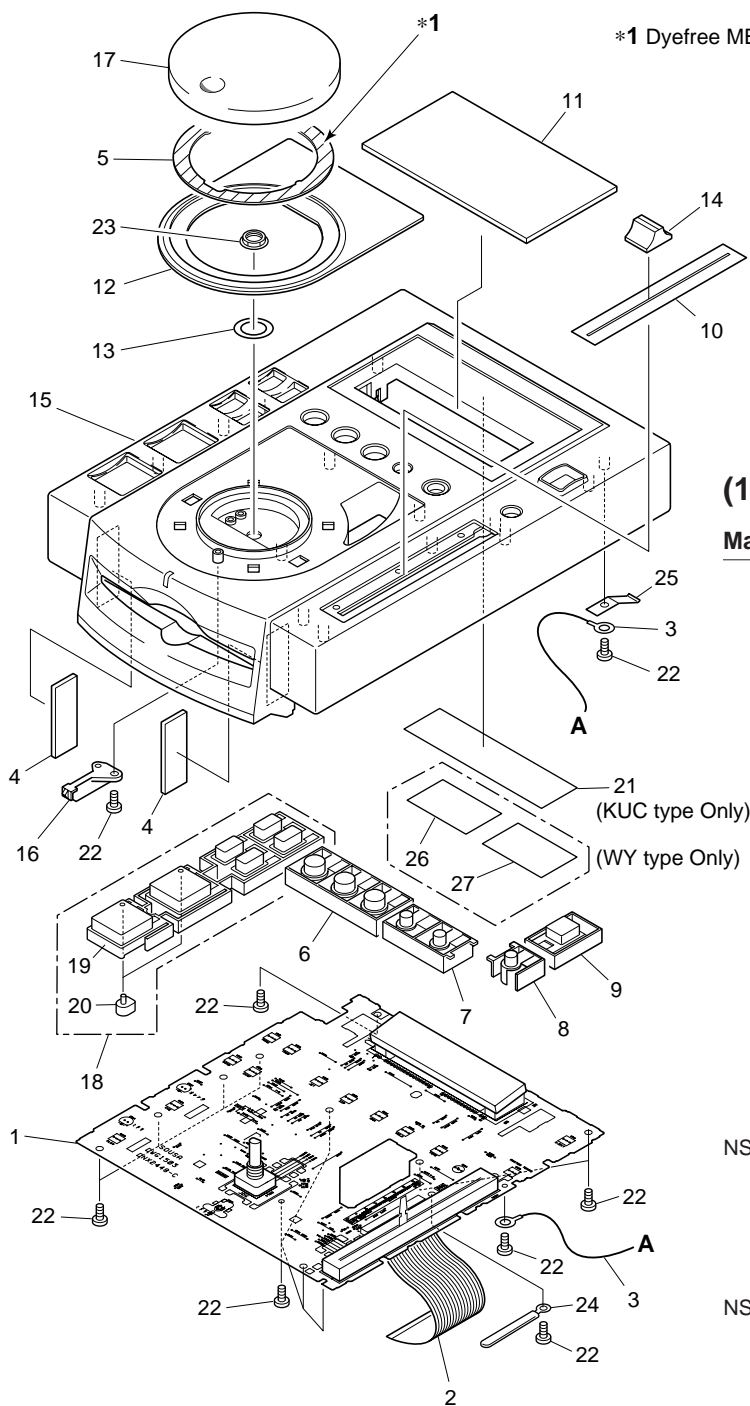

(1) EXTERIOR (2/2) PARTS LIST

Mark	No.	Description	Part No.
	1	DISPLAY BOARD ASSY	DWG1503
	2	36P F-F-C/60V	DDD1131
	3	Earth Lead Unit/300V	PDF1104
	4	Cushion C	DEC2259
	5	POM Ring	DNK3556
	6	Knob B	DAC1891
	7	Time Knob	DAC1892
	8	MT Knob	DAC1893
	9	Eject Knob	DAC1894
	10	Slide Sheet	DAH1855
	11	Display Plate	DAH1886
	12	Ring Plate	DAH1887
	13	Jog Washer	DBF1001
	14	Slide Knob	DNK2936
	15	Control Panel	DNK3552
	16	Disc Indicator	DNK3555
	17	Jog Dial	DNK3625
	18	Knob A Assy	DXA1846
NSP	19	Knob A	DAC1890
	20	LED Lens	PNW2019
	21	65 Label	See Contrast table (2)
	22	Screw	BPZ30P080FZK
	23	Nut (M9)	DBN1004
NSP	24	Binder	Z09-061
	25	Earth Plate	VBK1070
	26	Caution Label	See Contrast table (2)
NSP	27	Caution Label HE	See Contrast table (2)

(2) CONTRAST TABLE

CDJ-100S/KUC, RL and WY are constructed the same except for the following:

Mark	No.	Symbol and Description	Part No.			Remarks
			KUC type	RL type	WY type	
NSP	21	65 Label	ORW1069	Not used	Not used	
	26	Caution Label	Not used	Not used	VRW1094	
	27	Caution Label HE	Not used	Not used	VRW1297	

2.4 SLOT-IN MECHANISM ASSY

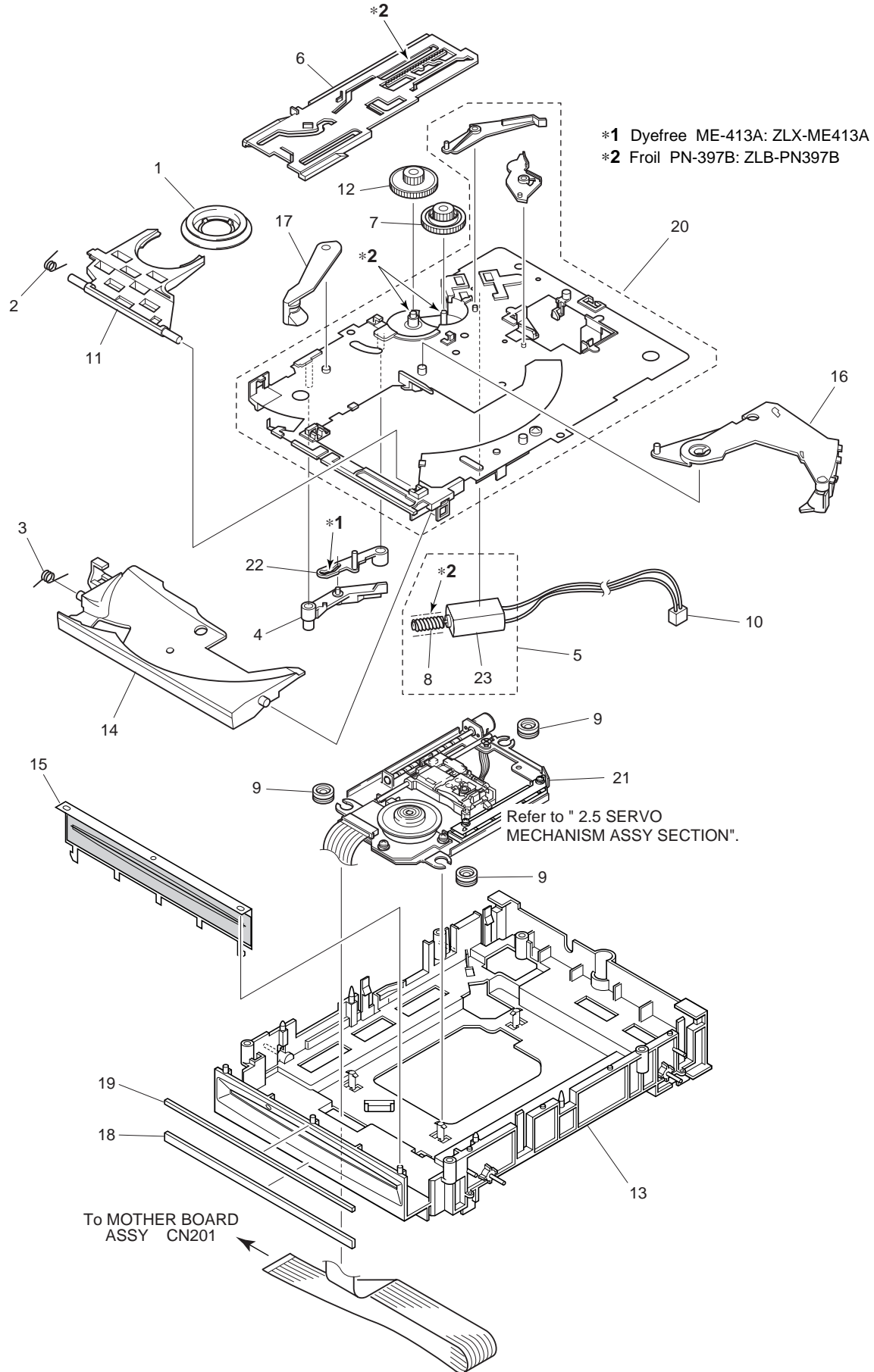

■ SLOT-IN MECHANISM ASSY PARTS LIST

Mark	No.	Description	Part No.	Mark	No.	Description	Part No.
	1	Clamper Assy	DXA1821		16	Eject Lever	DNK3548
	2	Clamp Spring	DBH1374		17	Loading Lever	DNK3406
	3	Guide Spring	DBH1375		18	Cushion A	DEC2257
	4	Lever B	DNK3558		19	Cushion B	DEC2258
	5	Loading Motor Assy-S	DEA1008		20	Loading Base Assy-S	DXX2431
	6	Main Cam	DNK3407		21	Servo Mechanism Assy-S	DXX2432
	7	Loading Gear	DNK3409		22	Lever A	DNK3564
NSP	8	Worm Gear	DNK3410	NSP	23	Loading Motor	DXM1093
	9	Mount Bush	DEB1328				
	10	Connector Assy	PF02PY-B27				
	11	Clamp Arm	DNK3404				
	12	Drive Gear	DNK3565				
	13	Float Base Assy	DXB1683				
	14	Disc Guide	DNK3478				
	15	Front Sheet	DED1132				

2.5 SERVO MECHANISM ASSY

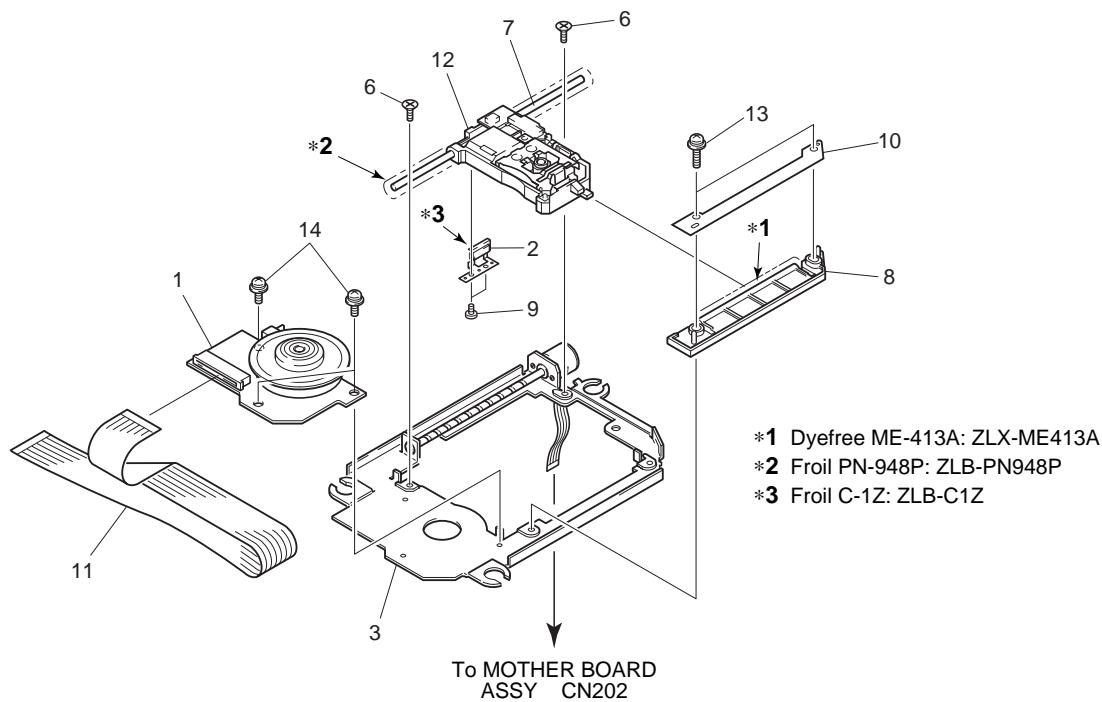

■ SERVO MECHANISM ASSY PARTS LIST

Mark	No.	Description	Parts No.	Mark	No.	Description	Parts No.
	1	Spindle Motor	DXM1084		8	Sub Guide Shaft	DNK3638
	2	Screw Guide	DNK3238		9	Screw	ABA7022
	3	Pulse Motor Frame	DXM1085		10	Stopper	DNH2355
	4					
	5					
	6	Screw	CMZ20P060FMC		11	SPD Card	DDX1165
	7	Guide Shaft	DLA1731	NSP	12	Pickup Assy	DWY1069
					13	Screw	PMA20P080FMC
					14	Screw	PMH20P040FCC

3. SCHEMATIC DIAGRAM

Note: When ordering service parts, be sure to refer to "EXPLODED VIEWS AND PARTS LIST" or "PCB PARTS LIST".

3.1 OVERALL CONNECTION DIAGRAM

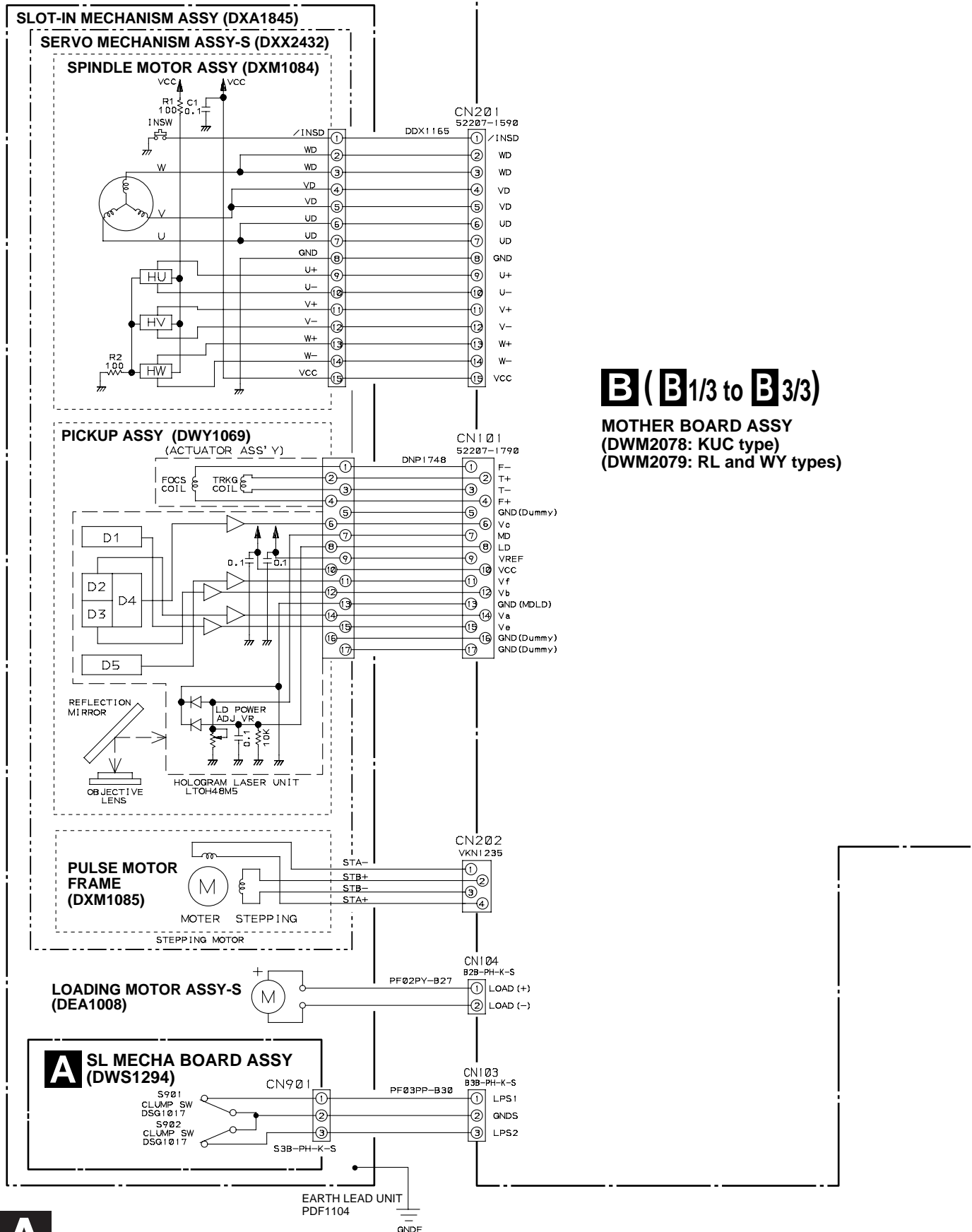

B (B 1/3 to B 3/3)

MOTHER BOARD ASSY
(DWM2078: KUC type)
(DWM2079: RL and WY types)



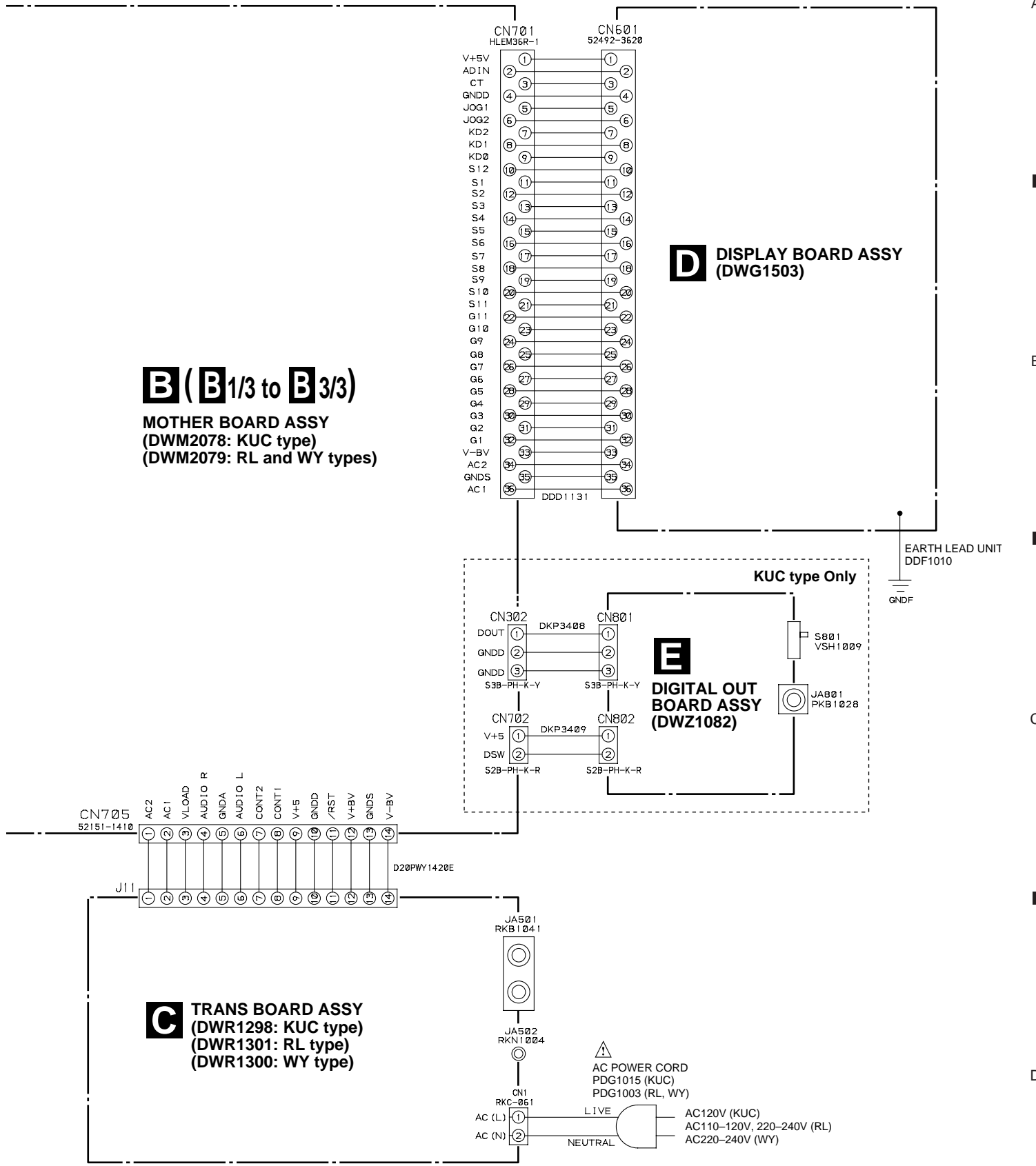

A

B

C

D

3.2 MOTHER BOARD ASSY (1/3)

A

SIGNAL ROUTE

- ▶ : RF and Audio Signal Route
- (F) ▶ : Focus Servo Loop
- (T) ▶ : Tracking Servo Loop
- (L) ▶ : LOADING Drive

Note

□ □ □ Chip

RESISTOR

No mark Carbon film resistor (Ω)

No mark $\frac{1}{10}W$

COIL

No mark : LAU (H)
LC : LCTA

CAPACITOR

No mark electrolytic: CEAT (μF)

AL : CEAL (μF)

JA : CEJA (μF)

No mark ceramic : CKSOYF (μF)

YB : CKSOYB (μF)

TL : CFTLA (μF)

CH : CCSQCH (F)

B

C

D

To SPINDLE MOTOR ASSY

To LOADING MOTOR ASSY

To PICKUP ASSY

A

B 3/3

B 1/3

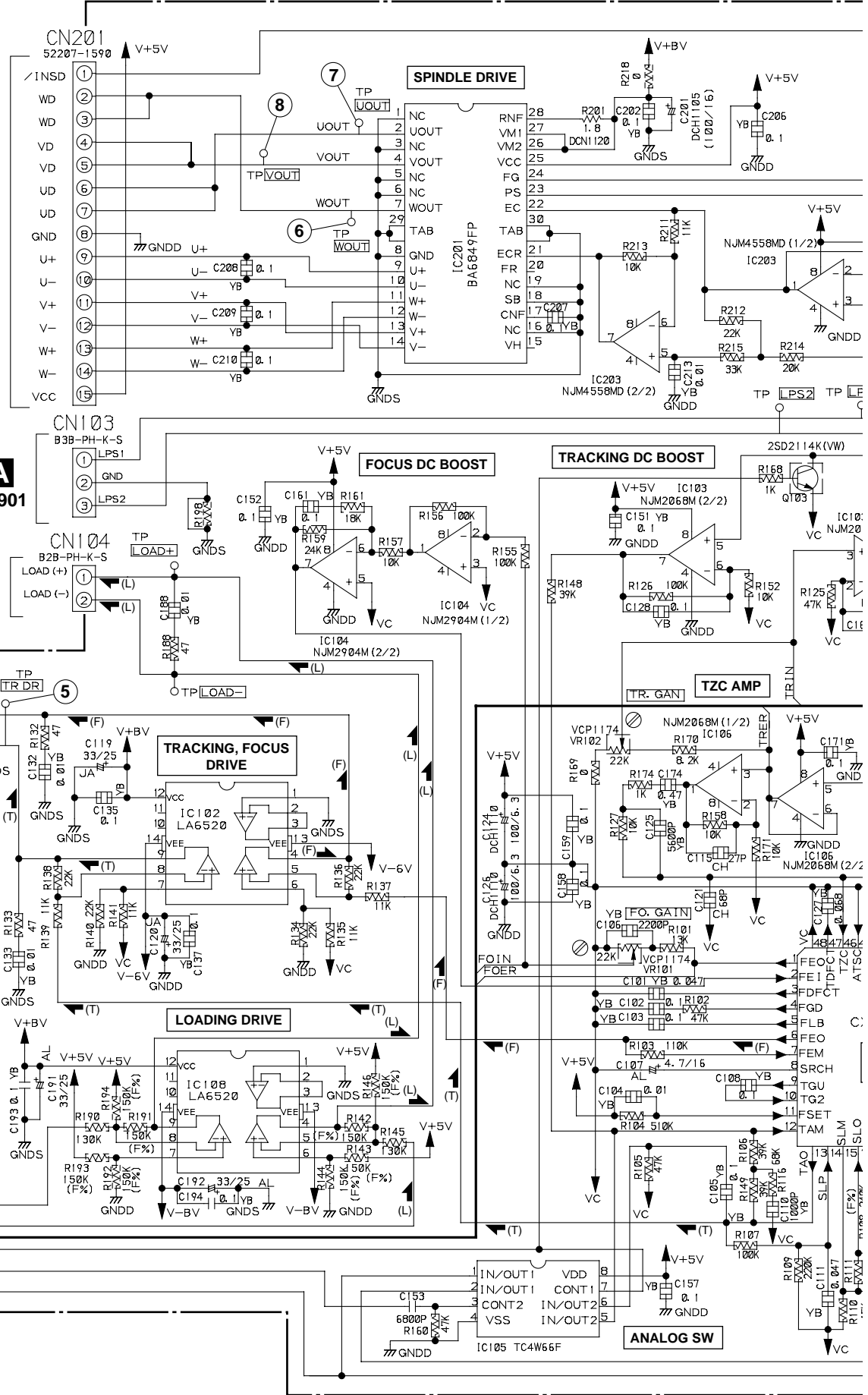

B3/3

B1/3

MOTHER BOARD ASSY (1/3)
(DWM2078: KUC type)
(DWM2079: RL and WY types)

KUC ONLY

E
CN801

B2/3

B

C

B3/3

D

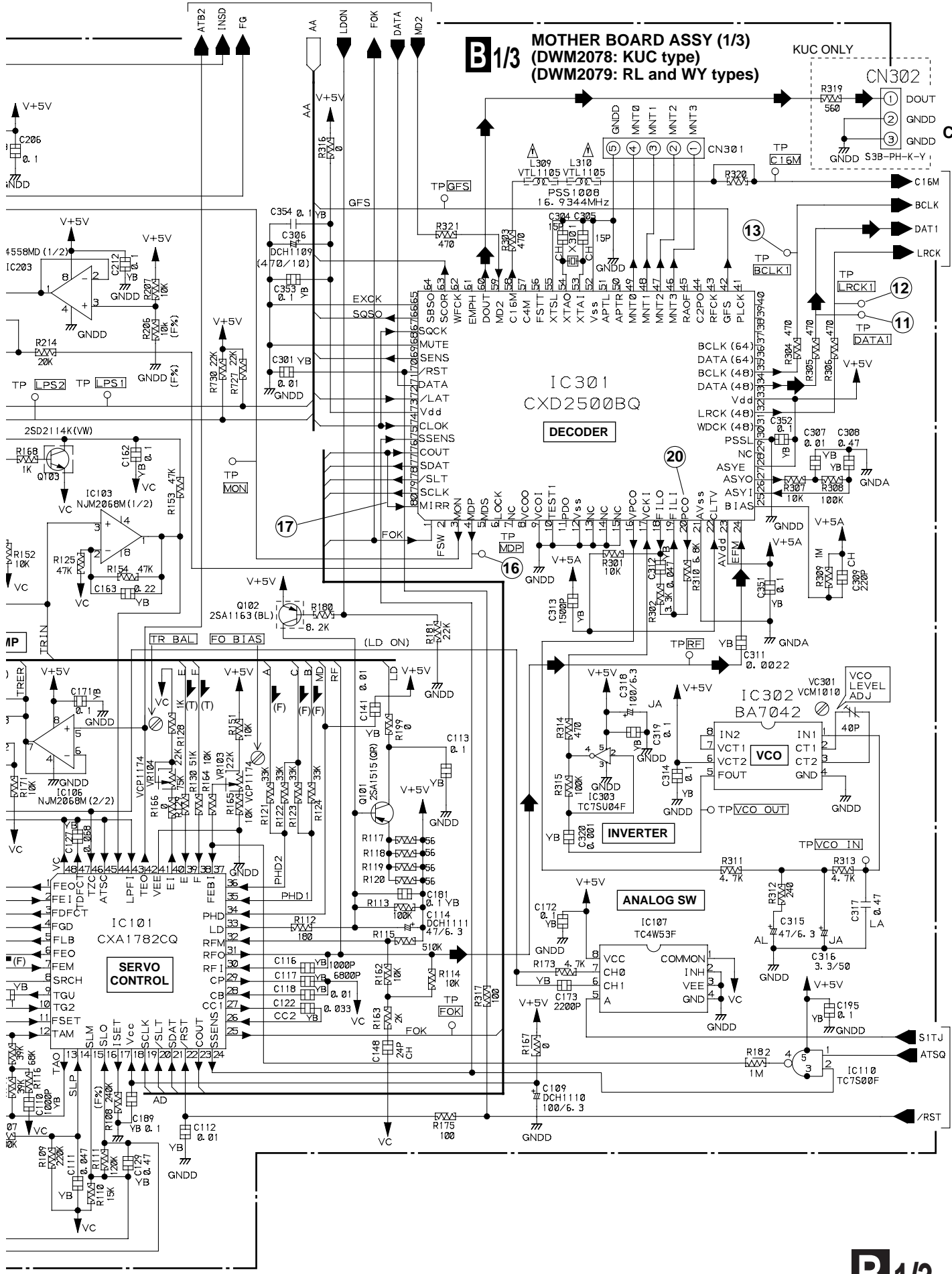

Waveforms of MOTHER BOARD ASSY (1/3)

Note : The encircled numbers denote measuring points in the schematic diagram.

*1 14T-JUMP : After switching to the pause mode, Press the manual search key.

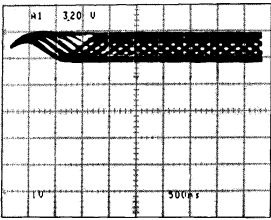
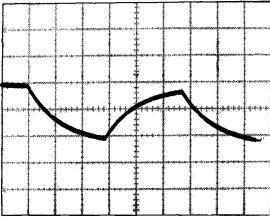
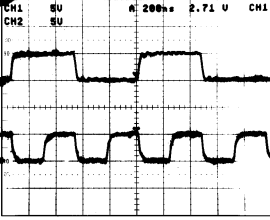
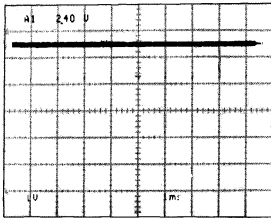
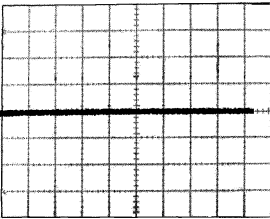
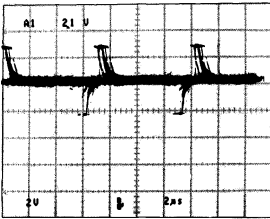
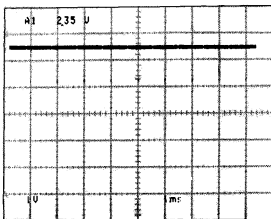
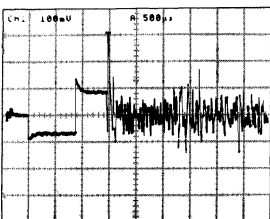
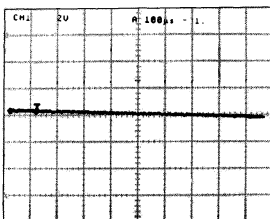
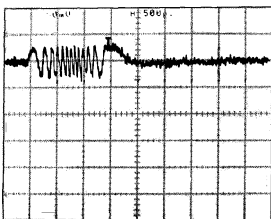
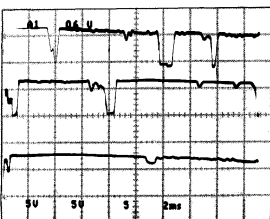
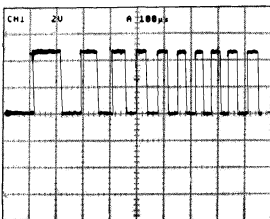
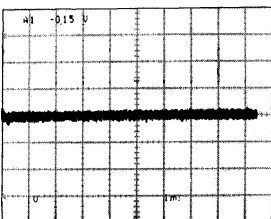
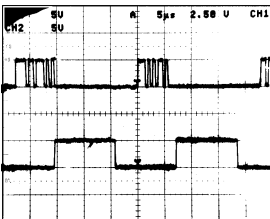
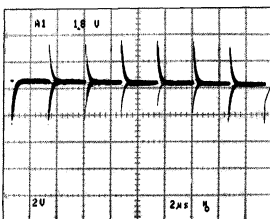
<p>① TP1 – Pin 1 : PLAY MODE (RF) 1 V/div, 500 ns/div</p>  <p>GND</p>	<p>④ TP – FODR : TEST MODE (FOCUS IN) 5 V/div, 200 ms/div</p>  <p>+5V GND -5V</p>	<p>⑪ TP – DATA1 ⑬ TP – BCLK1 PLAY MODE 5 V/div, 200 ns/div</p>  <p>GND GND</p>
<p>② TP1 – Pin 6 : PLAY MODE (FOER) 1 V/div, 1 ms/div</p>  <p>GND</p>	<p>⑤ TP – TRDR : PLAY MODE 1 V/div, 1 ms/div</p>  <p>GND</p>	<p>⑯ TP – MDP : PLAY MODE 2 V/div, 2 μs/div</p>  <p>GND</p>
<p>③ TP1 – Pin 2 : PLAY MODE (TRER) 1 V/div, 1 ms/div</p>  <p>GND</p>	<p>⑤ TP – TRDR : 14T-JUMP (*1) MODE 1 V/div, 200 μs/div</p>  <p>GND</p>	<p>⑰ IC301-Pin80(MIRR) : PLAY MODE 2 V/div, 100 μs/div</p>  <p>GND</p>
<p>③ TP1 – Pin 2 : 14T-JUMP (*1) MODE (TRER) 1 V/div, 2 ms/div</p>  <p>GND</p>	<p>⑥ TP – WOUT ⑦ TP – UOUT ⑧ TP – VOUT PLAY MODE 5 V/div, 2 ms/div</p>  <p>GND GND GND</p>	<p>⑰ IC301-Pin80(MIRR) : 14T-JUMP (*1) MODE 2 V/div, 100 μs/div</p>  <p>GND</p>
<p>④ TP – FODR : PLAY MODE 1 V/div, 1 ms/div</p>  <p>GND</p>	<p>⑪ TP – DATA1 ⑫ TP – LRCK1 PLAY MODE 5 V/div, 5 μs/div</p>  <p>GND GND</p>	<p>⑳ IC301 – Pin20 (PCO) : PLAY MODE 2 V/div, 2 μs/div</p>  <p>GND</p>

Voltages of MOTHER BOARD ASSY (1/3)

Set: DJ mode PLAY

**IC101
(CXA1782CQ)**

No.	Voltage [V]	No.	Voltage [V]	
1	+2.5	25	+4.9	
2		26	+0.6	
3		27	+0.7	
4		28	+1.6	
5		29	+2.3	
6	+2.7	30	+2.5	
7	+2.5	31	+3.5	
8	+2.7	32	+2.5	
9	+2.5	33	+3.4	
10		34	0	
11	+0.8	35	+2.5	
12	+2.5	36		+2.5
13		37		
14		38		
15		39		
16	40	+2.2		
17	+1.2	41	0	
18	+4.9	42	+2.5	
19	0 to +5	43		
20		44		
21	45	+2.4		
22	+4.9		46	
23	0 to +5	47		
24		48	+2.5	

**IC201
(BA6849FP)**

No.	Voltage [V]	No.	Voltage [V]
1	0	16	0
2	+6.0	17	+0.5
3	0	18	0
4	+6.0	19	
5	0	20	+2.6
6		21	
7	+6.0	22	+2.5
8	0	23	+4.9
9	+2.5	24	+2.4
10		25	+4.9
11		26	+7.5
12		27	
13	28	0	
14	29		
15	+0.5	30	

**IC102
(LA6520)**

No.	Voltage [V]
1	0
2	
3	
4	-0.3
5	+1.6
6	
7	
8	
9	-0.1
10	0
11	
12	+8.0
13	-8.7
14	

**IC203
(NJM4558MD)**

No.	Voltage [V]
1	+2.5
2	
3	
4	0
5	+2.6
6	
7	+2.7
8	+4.9

**IC103
(NJM2068M)**

No.	Voltage [V]
1	+2.5
2	
3	
4	0
5	+2.5
6	
7	
8	+4.9

**IC104
(NJM2904M)**

No.	Voltage [V]
1	+2.5
2	
3	
4	0
5	+2.5
6	
7	
8	+4.9

**IC301
(CXD2500BQ)**

No.	Voltage [V]	No.	Voltage [V]	No.	Voltage [V]	No.	Voltage [V]
1	+4.9	21	0	41	+2.3	61	0
2	0	22	+2.5	42	+4.9	62	+2.5
3	+4.9	23	+4.9	43	+2.5	63	0 to +5
4	+2.7	24	+1 to +4	44	0	64	0
5	0	25	+0.9	45	+4.9	65	
6	+4.9	26	+2.5	46	+4.4	66	0 to +5
7	0	27		47	0	67	
8	+4.9	28	+4.9	48		68	0
9	0	29	0	49	+1.2	69	0 to +5
10		30		50		70	+4.9
11		31	+2.5	51	0	71	0 to +5
12		32	0 to 5	52		72	
13		33	+5	53	+2.6	73	+4.9
14	34	0 to 5	54	+2.7	74	0 to +5	
15	35		55	0	75		
16	+2.6	36	+2.5	56	+2.8		76
17	+2.5	37	+2.4	57	+1.4		77
18	0	38	+2.5	58	+2.1		78
19	+2.6	39	0	59	0		79
20		40	+4.9	60			80

**IC105
(TC4W66F)**

No.	Voltage [V]
1	+2.6
2	+2.5
3	0
4	
5	+2.5
6	
7	0
8	+4.9

**IC106
(NJM2068M)**

No.	Voltage [V]
1	+2.5
2	
3	
4	0
5	+2.5
6	
7	
8	+4.9

**IC107
(TC4W53F)**

No.	Voltage [V]
1	+2.5
2	0
3	
4	
5	
6	+2.5
7	
8	+4.9

**IC302
(BA7042)**

No.	Voltage [V]
1	+2.4
2	+2.1
3	
4	0
5	+3.5
6	+4.9
7	+2.4
8	

**IC108
(LA6520)**

No.	Voltage [V]
1	0
2	
3	
4	
5	+2.5
6	
7	
8	0
9	
10	+8.0
11	-8.7
12	
13	-8.7
14	

**IC303
(TC7SU04F)**

No.	Voltage [V]
1	0
2	+2.5
3	0
4	+2.6
5	+4.9

3.3 MOTHER BOARD ASSY (2/3)

B2/3 MOTHER BOARD ASSY (2/3)
(DWM2078: KUC type)
(DWM2079: RL and WY types)

SIGNAL ROUTE
➡ : RF and Audio Signal Route

B1/3

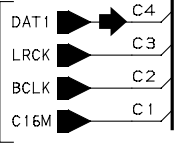

IC402 (MB814800-70PJ) Set: DJ MODE PLAY

Pin No.	1	2	3	4	5	6	7	8	9	10	11	12	13	14		
Voltage [V]	+4.9	0 to +5					0				0 to +5				+4.9	
Pin No.	15	16	17	18	19	20	21	22	23	24	25	26	27	28		
Voltage [V]	0				0 to +5				0				0 to +5			

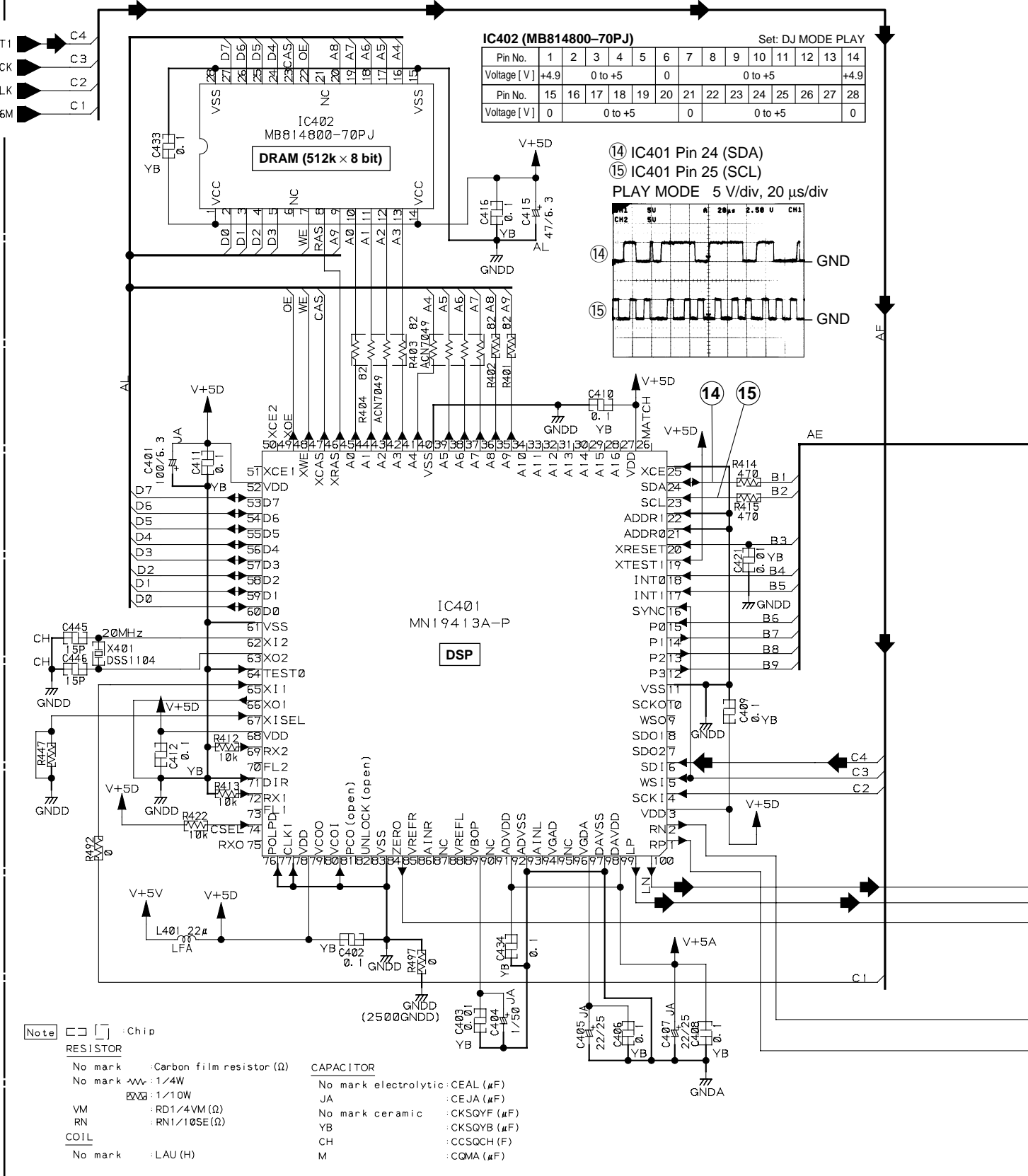
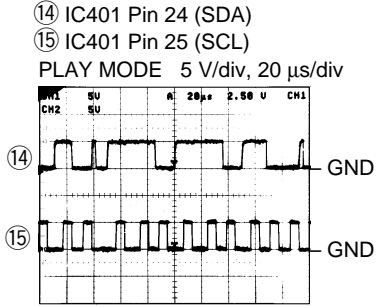

- Note** □ □ □ : Chip
- RESISTOR**
- No mark : Carbon film resistor (Ω)
 - No mark \sim : 1/4W
 - \square : 1/10W
 - VM : RD1/4VM (Ω)
 - RN : RN1/10SE (Ω)
- COIL**
- No mark : LAU (H)
- CAPACITOR**
- No mark electrolytic : CEAL (μF)
 - JA : CEJA (μF)
 - No mark ceramic : CKSQYF (μF)
 - YB : CKSQYB (μF)
 - CH : CCSQCH (F)
 - M : CQMA (μF)

IC401 (MN19413A-P) Set: DJ MODE PLAY

Pin No.	Voltage [V]	Pin No.	Voltage [V]	Pin No.	Voltage [V]	Pin No.	Voltage [V]
1	+1.5	26	0	51	+4.9	76	0
2	+1.5	27	+4.9	52		77	
3	+4.9	28		53		78	+4.9
4		29		54		79	0
5	0 to +5	30		55		80	
6		31	0	56	0 to +5	81	+4.9
7		32		57		82	
8	0	33		58		83	0
9		34		59		84	
10		35		60		85	+1.0
11	0	36		61	0	86	+2.4
12		37	0 to +5	62	+2.5	87	0
13		38		63	+2.6	88	+1.0
14		39		64	+4.9	89	+2.5
15	0 to +5	40	0	65	+2.4	90	0
16		41		66	+2.5	91	+4.9
17		42		67	0	92	0
18		43		68	+4.9	93	
19		44		69	0	94	+2.3
20	+4.9	45	0 to +5	70	+4.9	95	0
21		46		71		96	+1.5
22	0	47		72	0	97	0
23		48		73	+1.4	98	+4.9
24	0 to +5	49		74	+4.9	99	
25	0	50	0	75	0	100	+1.5

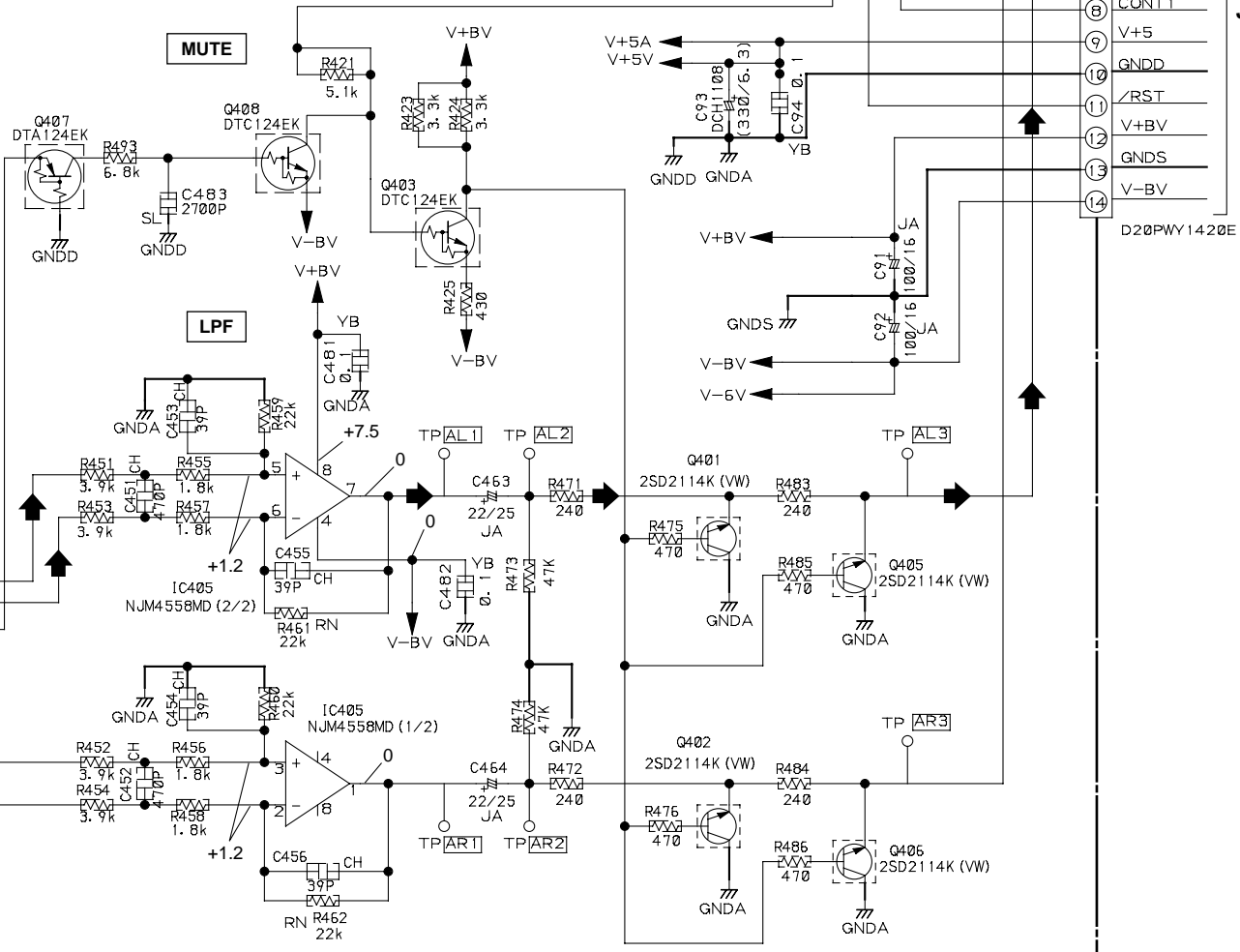
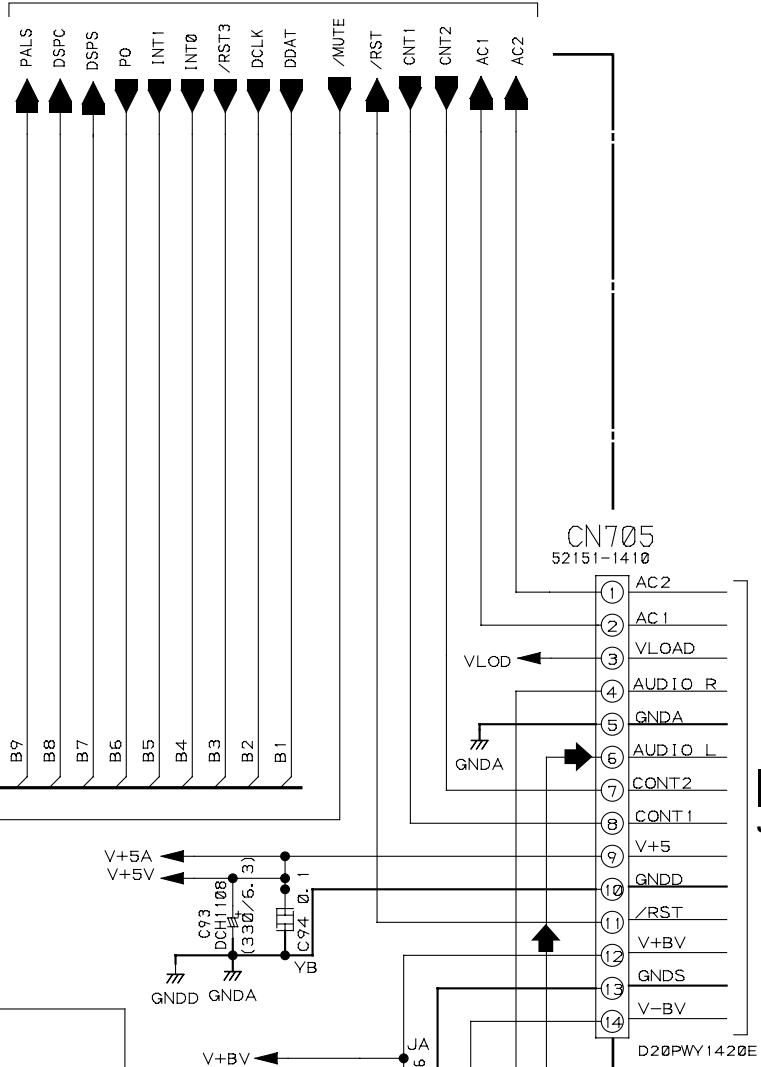

3.4 MOTHER BOARD ASSY (3/3)

Waveforms

- 9 TP - STA + PLAY MODE
- 10 TP - STA - 5 V/div, 5 μs/div

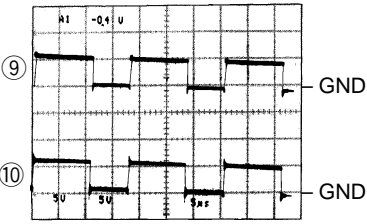

- 18 TP - RST : POWER ON 2 V/div, 5 ms/div

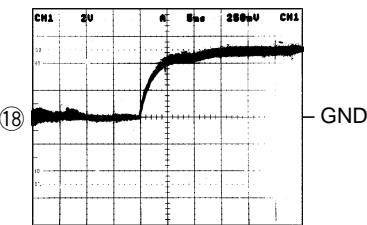

- 18 TP - RST : POWER OFF 2 V/div, 10 ms/div

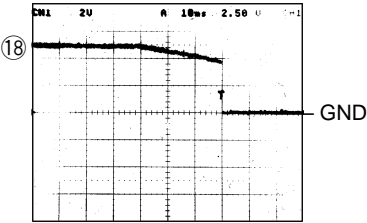

- 19 TP - RST3 : POWER ON 2 V/div, 1 μs/div

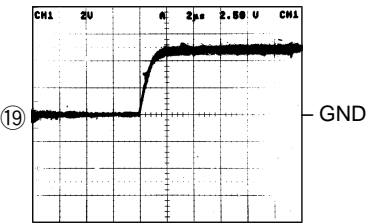

- 19 TP - RST3 : POWER OFF 2 V/div, 200 μs/div

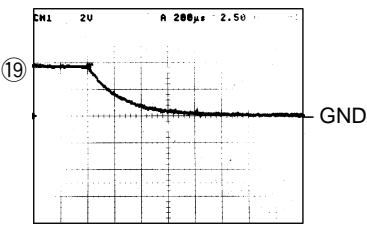

B3/3 MOTHER BOARD ASSY (3/3)
(DWM2078: KUC type)
(DWM2079: RL and WY types)

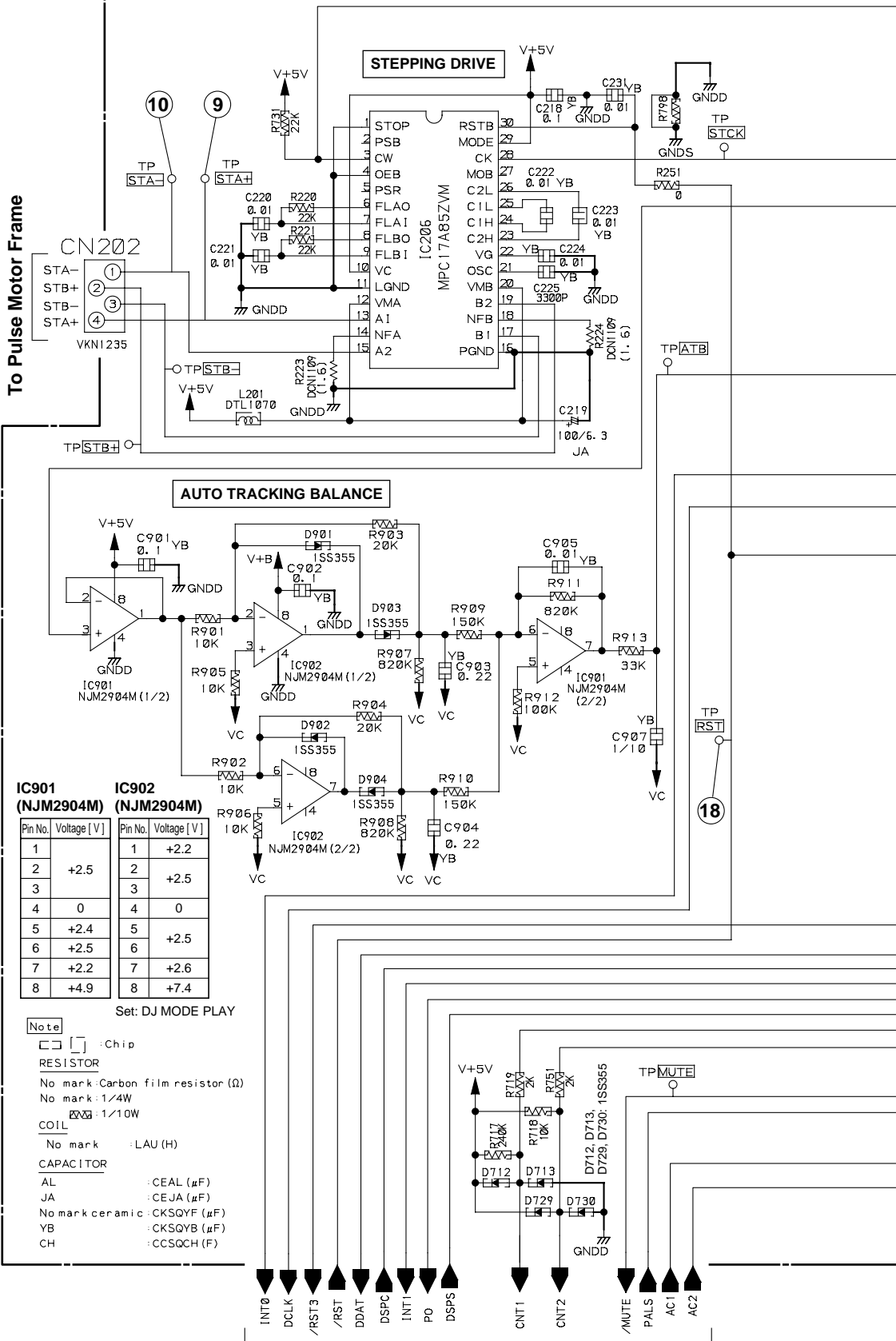

IC206 (MPC17A85ZVM)

Set: DJ MODE PLAY

Pin No.	1	2	3	4	5	6	7	8
Voltage [V]	0	+4.6	+4.9	0	+1.5	+0.2	+0.4	+0.5
Pin No.	9	10	11	12	13	14	15	16
Voltage [V]	+0.4	+4.9	0	+4.8	+1.5	+0.1	+0.5	0
Pin No.	17	18	19	20	21	22	23	24
Voltage [V]	+3.2	+0.2	+0.5	+4.8	+1.4	+1.9	+1.9	+7.2
Pin No.	25	26	27	28	29	30		
Voltage [V]	+2.5	+4.9	0 to +5	+4.9				

IC701 (PD4977B)

Set: DJ MODE PLAY

Pin No.	1	2	3	4	5	6	7	8	9	10	11	12	13	14	15	16	17	18	19	20
Voltage [V]									+4.9	+4.8	0	0	0 to +5	+4.9	0 to +5	0	0	0	0	0
Pin No.	21	22	23	24	25	26	27	28	29	30	31	32	33	34	35	36	37	38	39	40
Voltage [V]	+4.9	0 to +5	0	+2.3	+2.6	+2.5	+4.9	0	+4.9	0	+2.4	+2.2	0	+2.5	0	+2.5	+4.9			
Pin No.	41	42	43	44	45	46	47	48	49	50	51	52	53	54	55	56	57	58	59	60
Voltage [V]	+4.9	0	+3.0	0	0	+4.9	0	+4.9	0	+4.9	0 to +5	0	+4.9	0						
Pin No.	61	62	63	64	65	66	67	68	69	70	71	72	73	74	75	76	77	78	79	80
Voltage [V]	+4.9	0																		

SIGNAL ROUTE

(L) : LOADING DRIVE

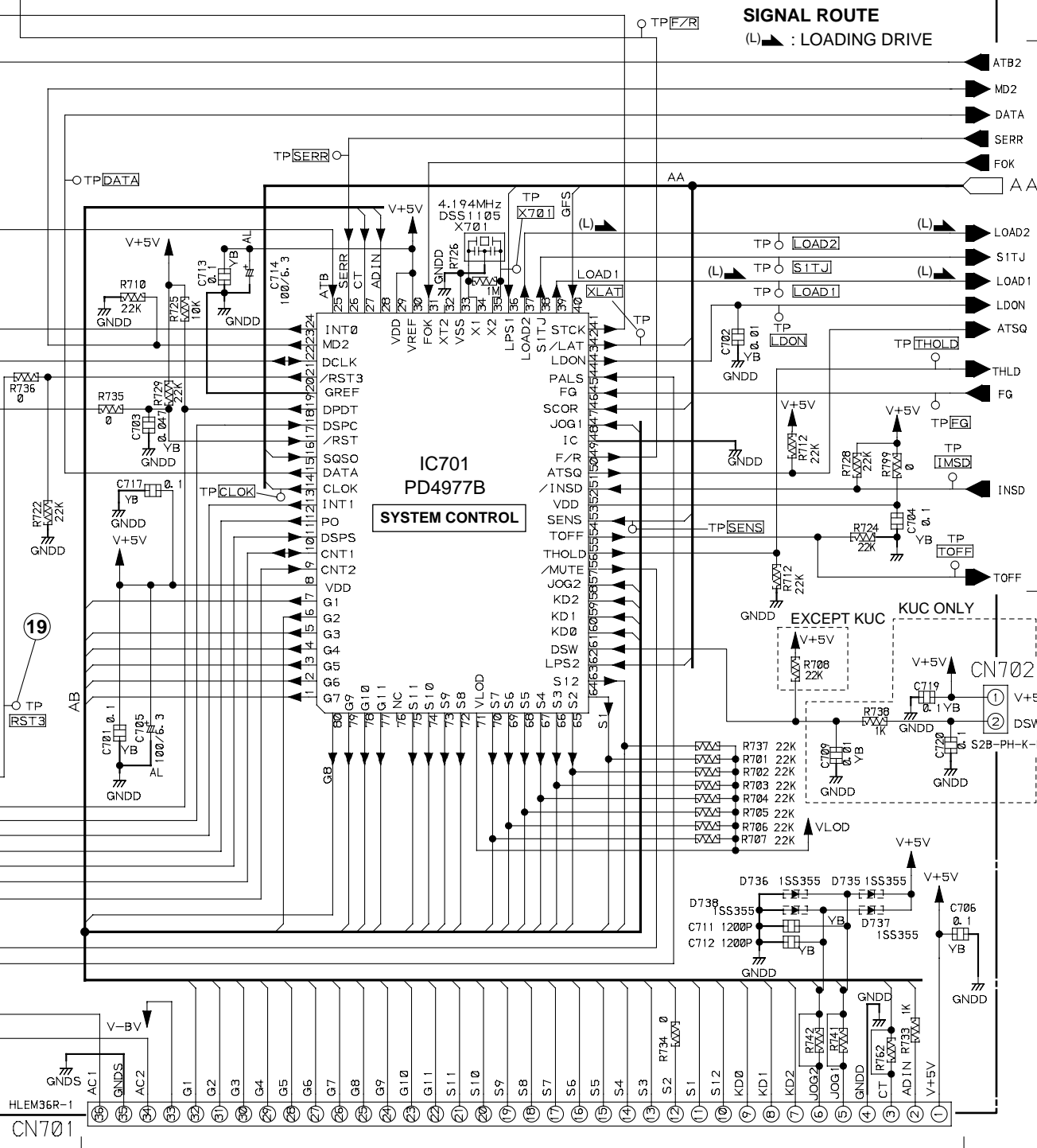

IC601

FFC DDD1131

3.5 TRANS BOARD ASSY

A

B

C

D

+5V REGULATOR

CAUTION: FOR CONTINUED PROTECTION AGAINST RISK OF FIRE. REPLACE ONLY WITH SAME TIME NO. ICP-N25, MFD BY ROHM CO., LTD. FOR IC91.

CAUTION: FOR CONTINUED PROTECTION AGAINST RISK OF FIRE. REPLACE ONLY WITH SAME TIME NO. ICP-N10, MFD BY ROHM CO., LTD. FOR IC92.

SIGNAL ROUTE
 ➔ : RF and Audio Signal Route

C TRANS BOARD ASSY
 (DWR1298: KUC type)
 (DWR1301: RL type)
 (DWR1300: WY type)

Note
 □ : Chip
RESISTOR
 No mark: Carbon film resistor (Ω)
 No mark: 1/4W
 VM : 1/10W
 RD1 : RD1/4VM (Ω)
CAPACITOR
 No mark electrolytic: CEAT (μF)
 No mark ceramic: CKSQYF (μF)

B2/3
CN705

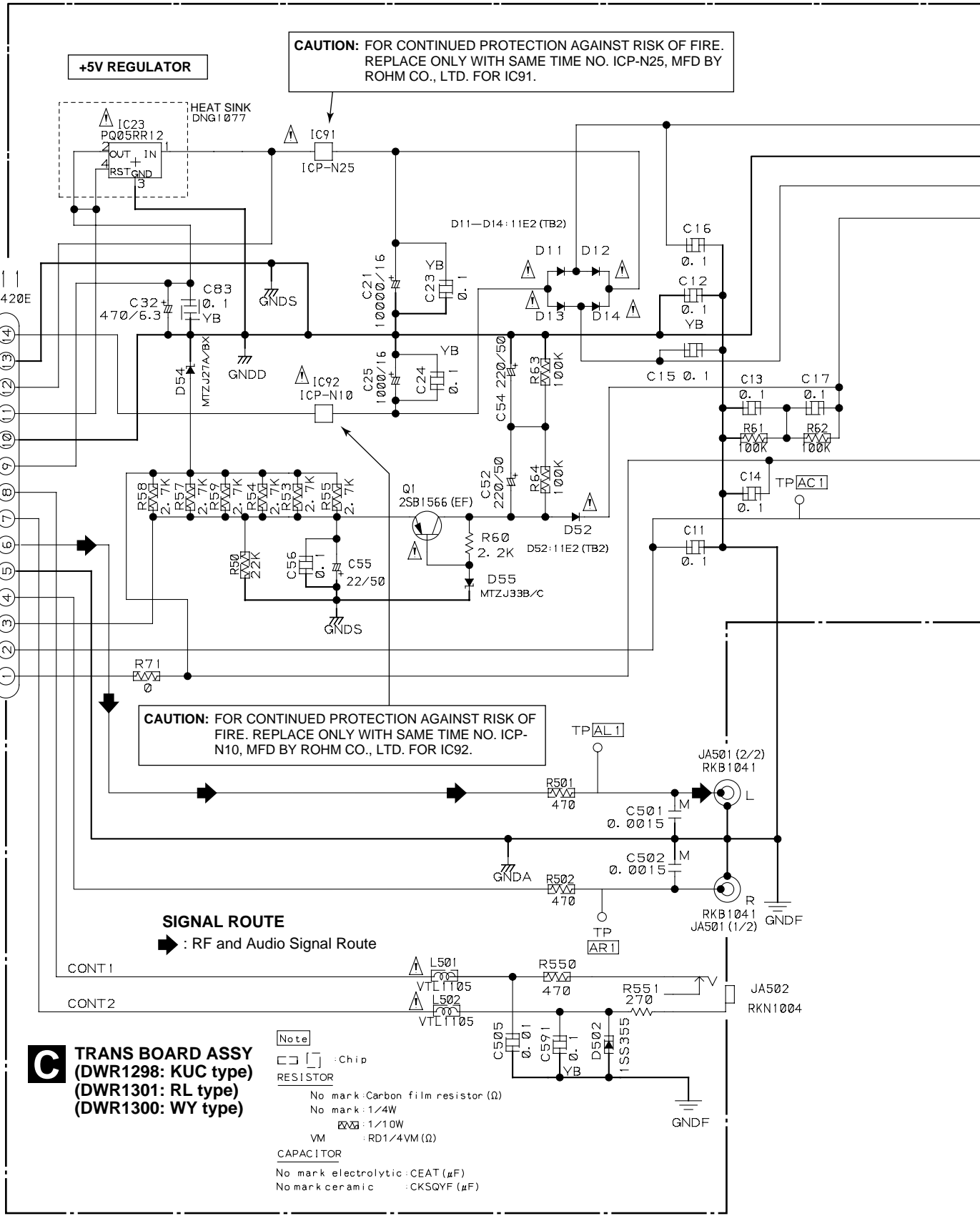

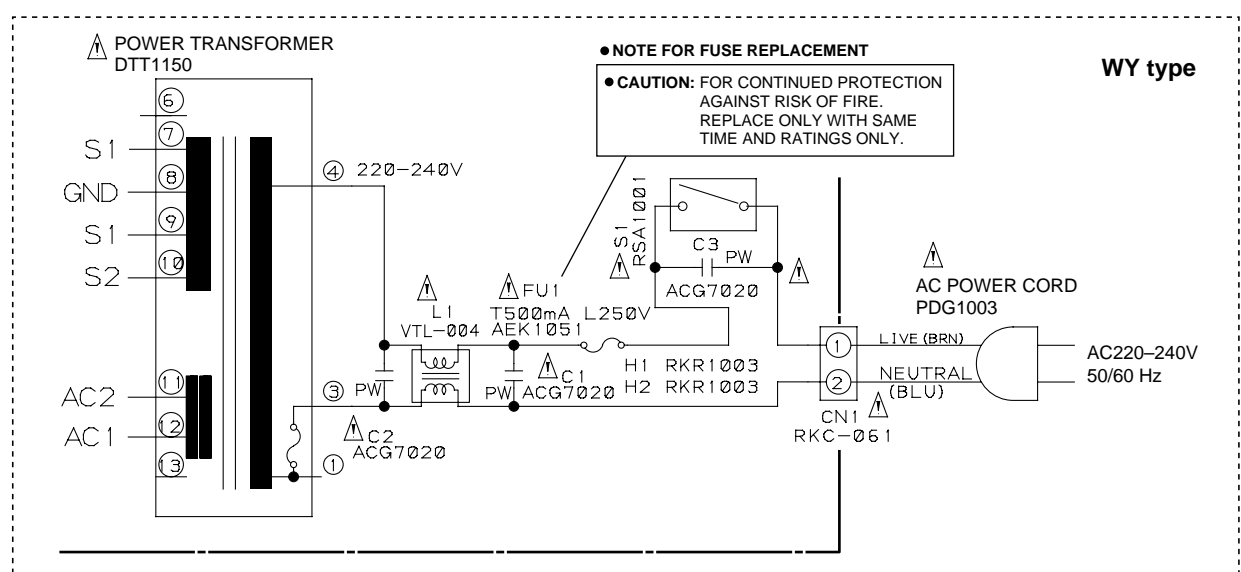
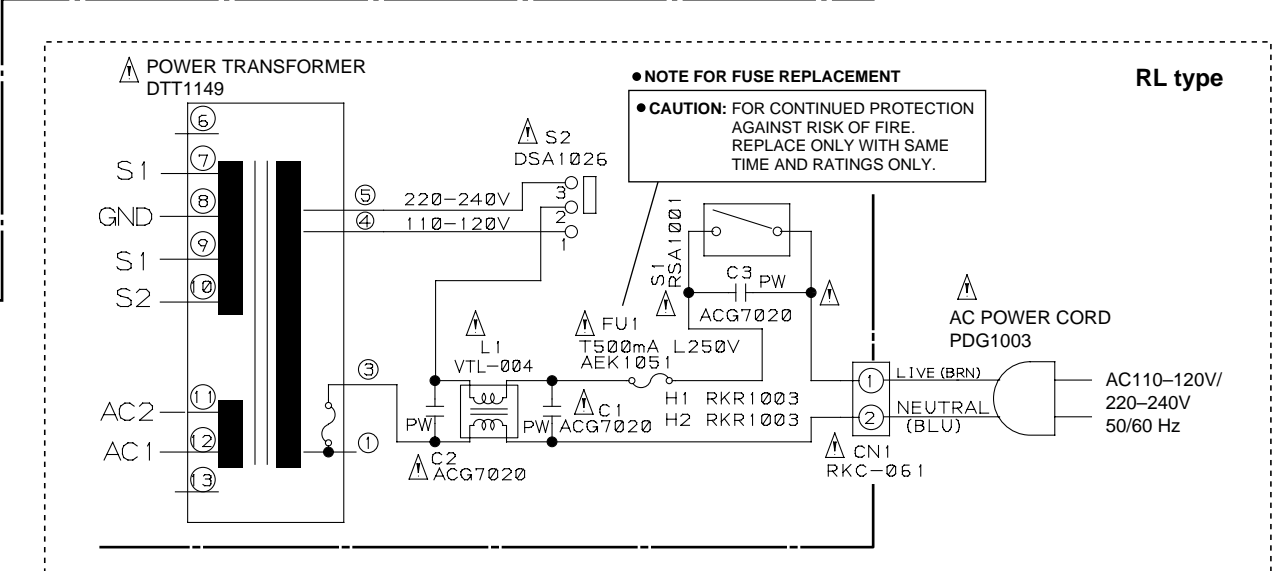
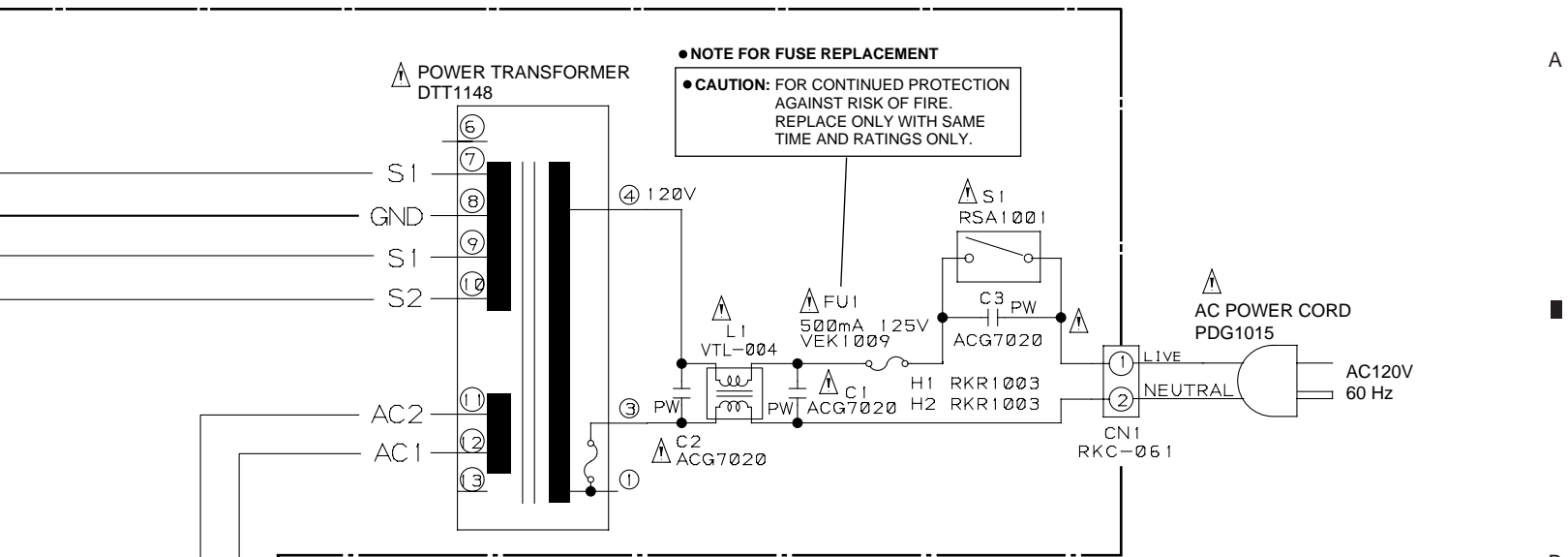

3.6 DISPLAY BOARD and DIGITAL OUT BOARD ASSEMBLIES

A

B

C

D

B3/3
CN701

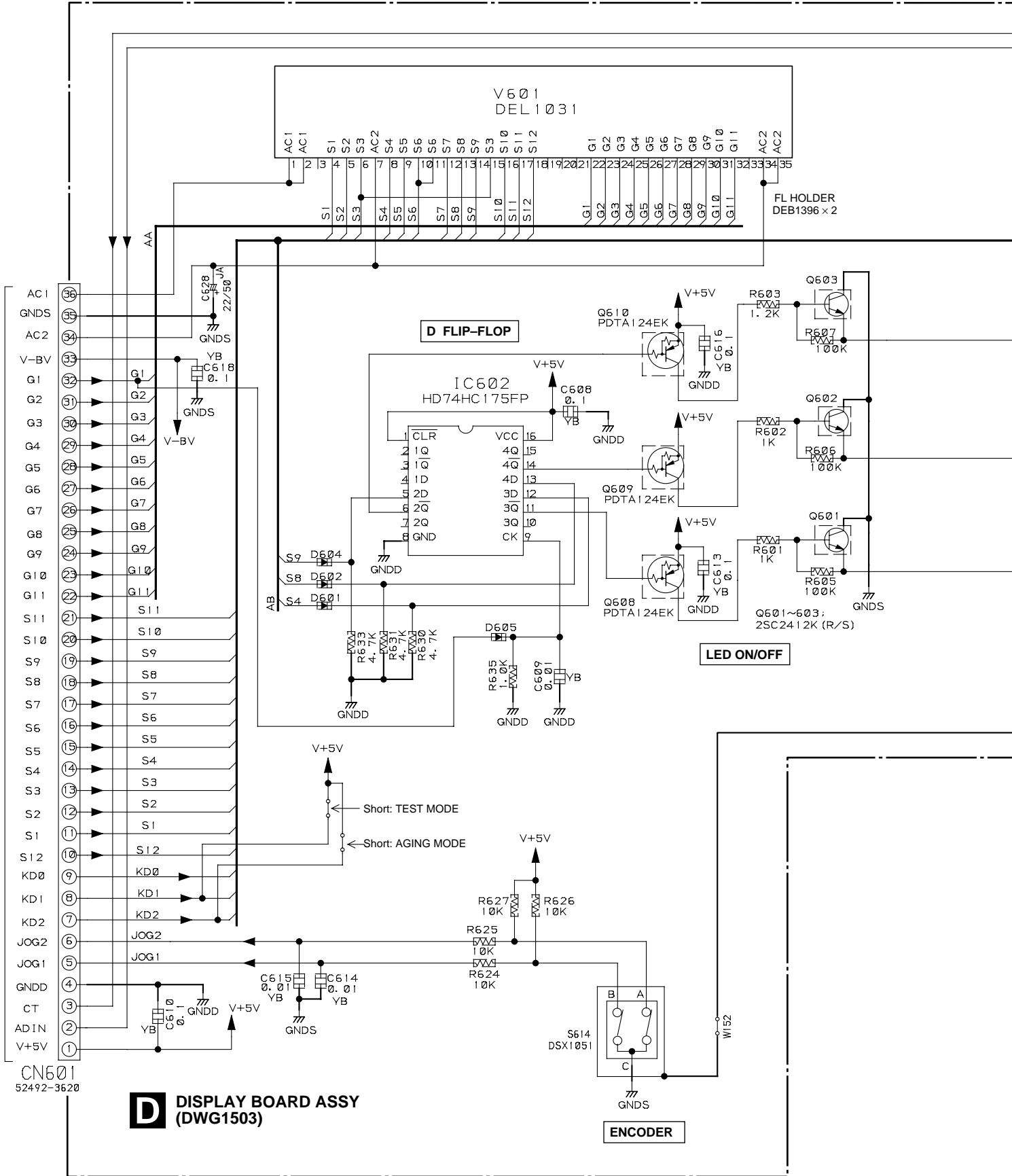

D DISPLAY BOARD ASSY (DWG1503)

ENCODER



Note

DIODE

No Mark 1SS355

CAPACITOR No mark: μF

No mark ceramic CKSQYF

RESISTOR Ω

No mark Carbon film resistor

No mark 1/10W

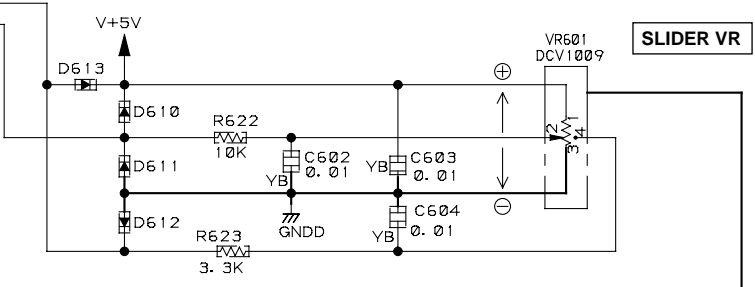

SWITCHES:

- S601: TRACK SEARCH (I◀◀)
- S602: SEARCH (◀◀)
- S603: PLAY/PAUSE (▶/||)
- S604: TRACK SEARCH (▶▶)
- S605: SEARCH (▶▶)
- S606: CUE
- S607: DIGITAL JOG BREAK (JET)
- S608: MASTER TEMPO
- S609: DIGITAL JOG BREAK (ZIP)
- S610: DIGITAL JOG BREAK (WAH)
- S611: EJECT (▲)
- S613: TIME MODE/AUTO CUE
- S615: DIGITAL JOG BREAK (HPLD)

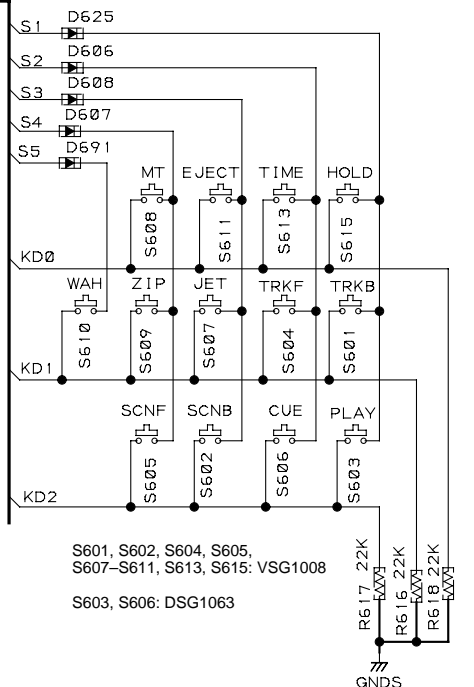
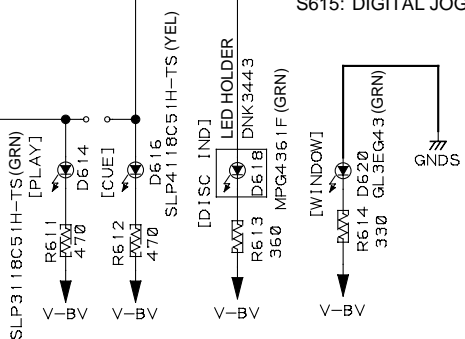

S601, S602, S604, S605, S607-S611, S613, S615: VSG1008
 S603, S606: DSG1063

KUC type Only

DIGITAL OUT BOARD ASSY (DWZ1082)

SIGNAL ROUTE

➡: RF and Audio Signal Route

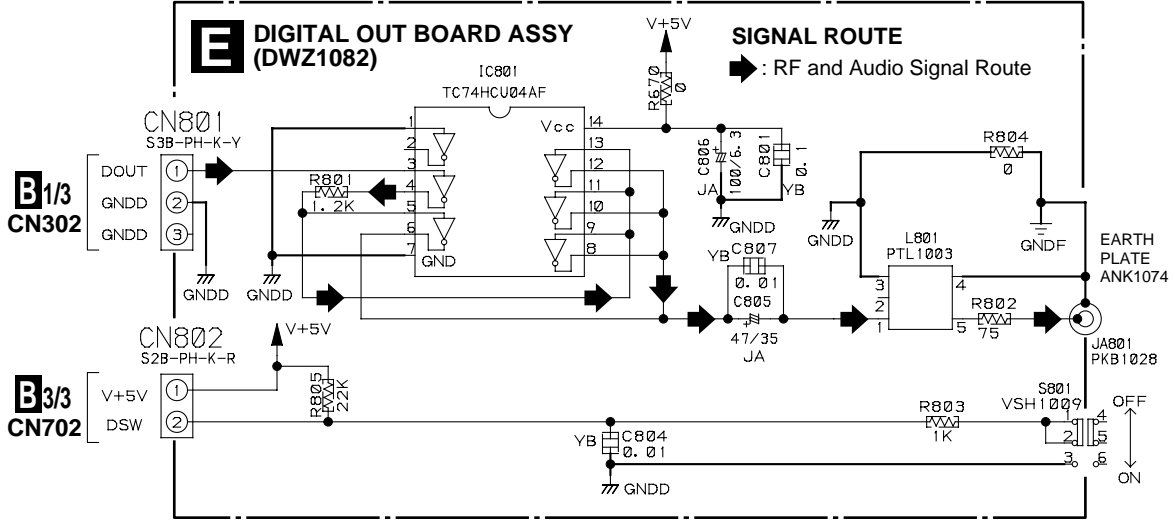

EARTH LEAD UNIT DDF1010



4. PCB CONNECTION DIAGRAM

4.1 SL MECHA BOARD, MOTHER BOARD, TRANS BOARD and DIGITAL OUT BOARD ASSEMBLIES

A

SIDE A

B MOTHER BOARD ASSY

SLOT-IN MECHANISM ASSY

Stepping Motor

Pickup Assy

Loading Motor Assy

A SL MECHA BOARD ASSY

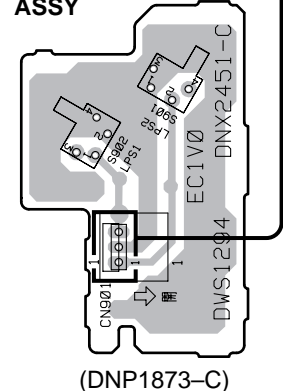

Spindle Motor Assy

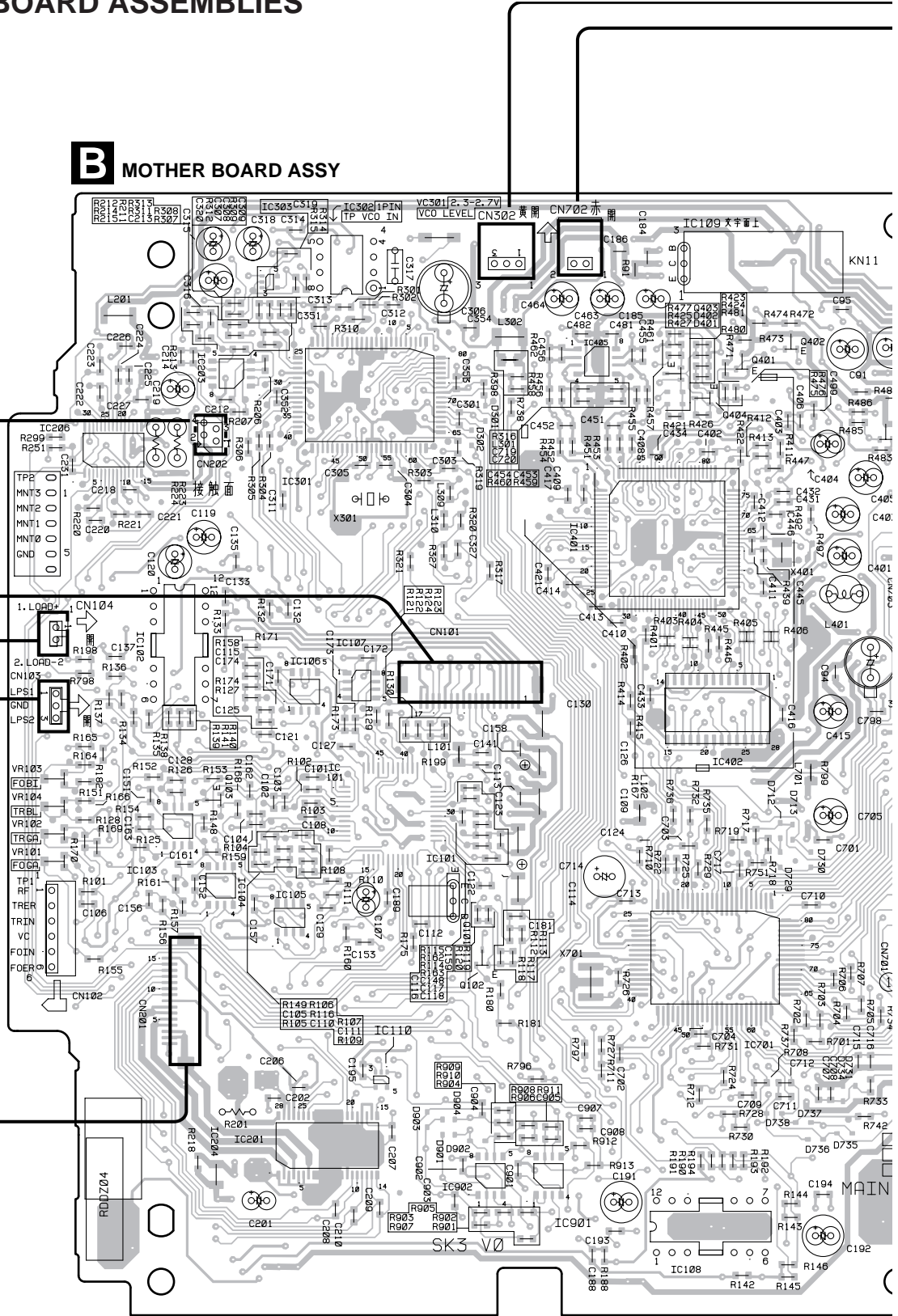

VR101-VR104	VC301				
IC206	IC303	IC302	IC405	IC109	Q403 Q404 Q401 Q402
IC203	IC301	IC401	IC402	IC701	
Q103	IC106	IC107	IC108	IC108	
IC103	IC104	IC105	IC101	Q101	Q102
	IC201	IC110	IC902	IC901	



D

B

C

1

2

3

4

SIDE A

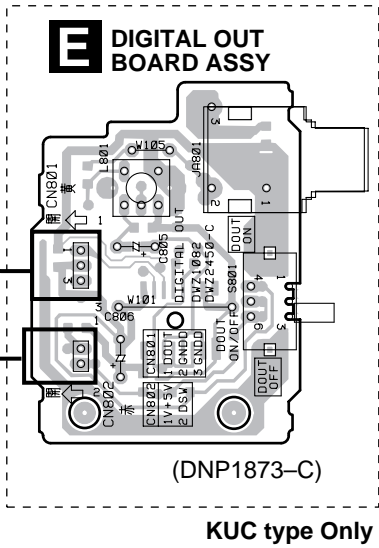
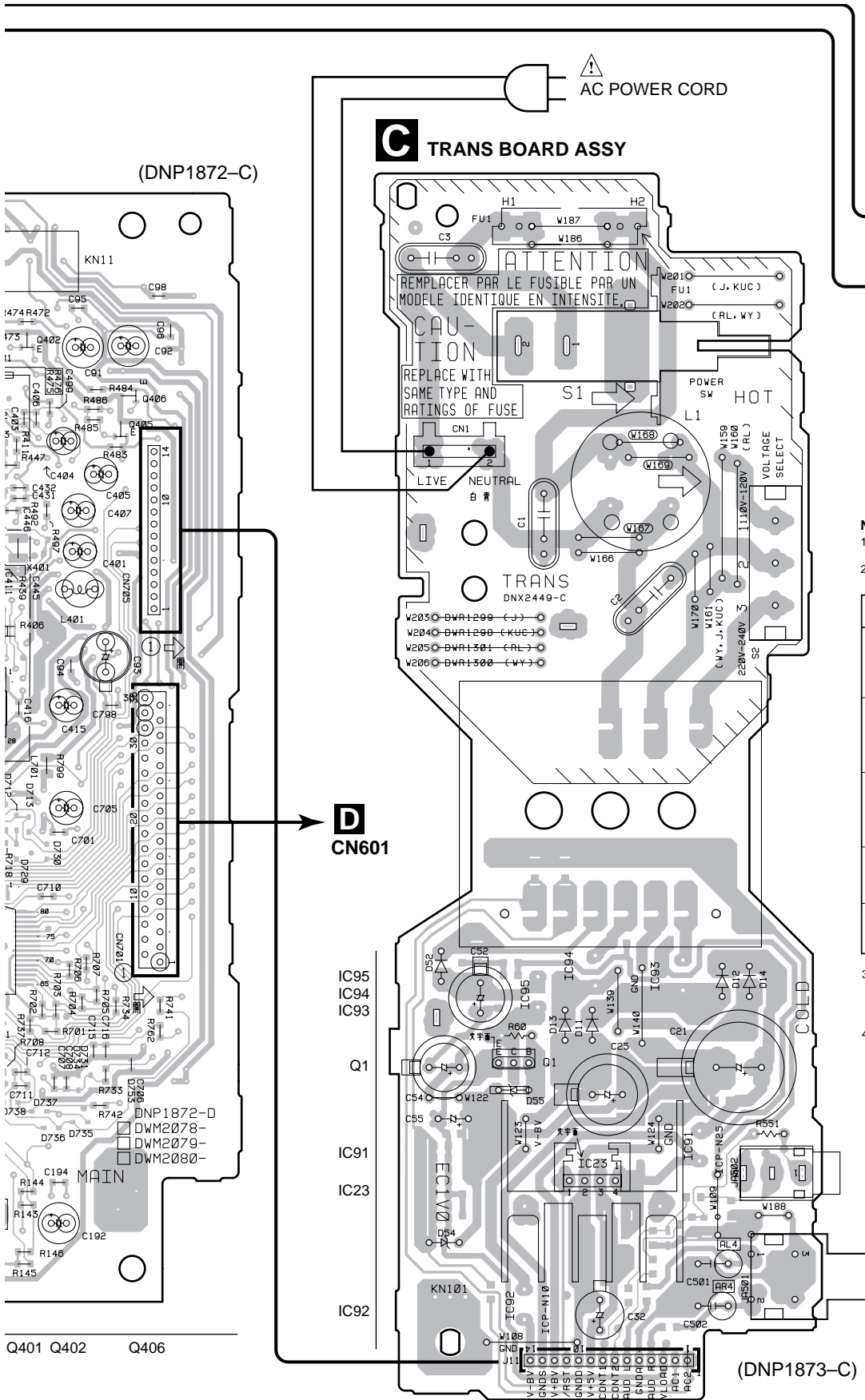

NOTE FOR PCB DIAGRAMS:

1. Part numbers in PCB diagrams match those in the schematic diagrams.
2. A comparison between the main parts of PCB and schematic diagrams is shown below.

Symbol in PCB Diagrams	Symbol in Schematic Diagrams	Part Name
		Transistor
		Transistor with resistor
		Field effect transistor
		Resistor array
		3-terminal regulator

3. The parts mounted on this PCB include all necessary parts for several destination.
For further information for respective destinations, be sure to check with the schematic diagram.

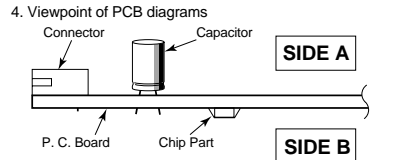

SIDE B

B MOTHER BOARD ASSY

(DNP1872-C)

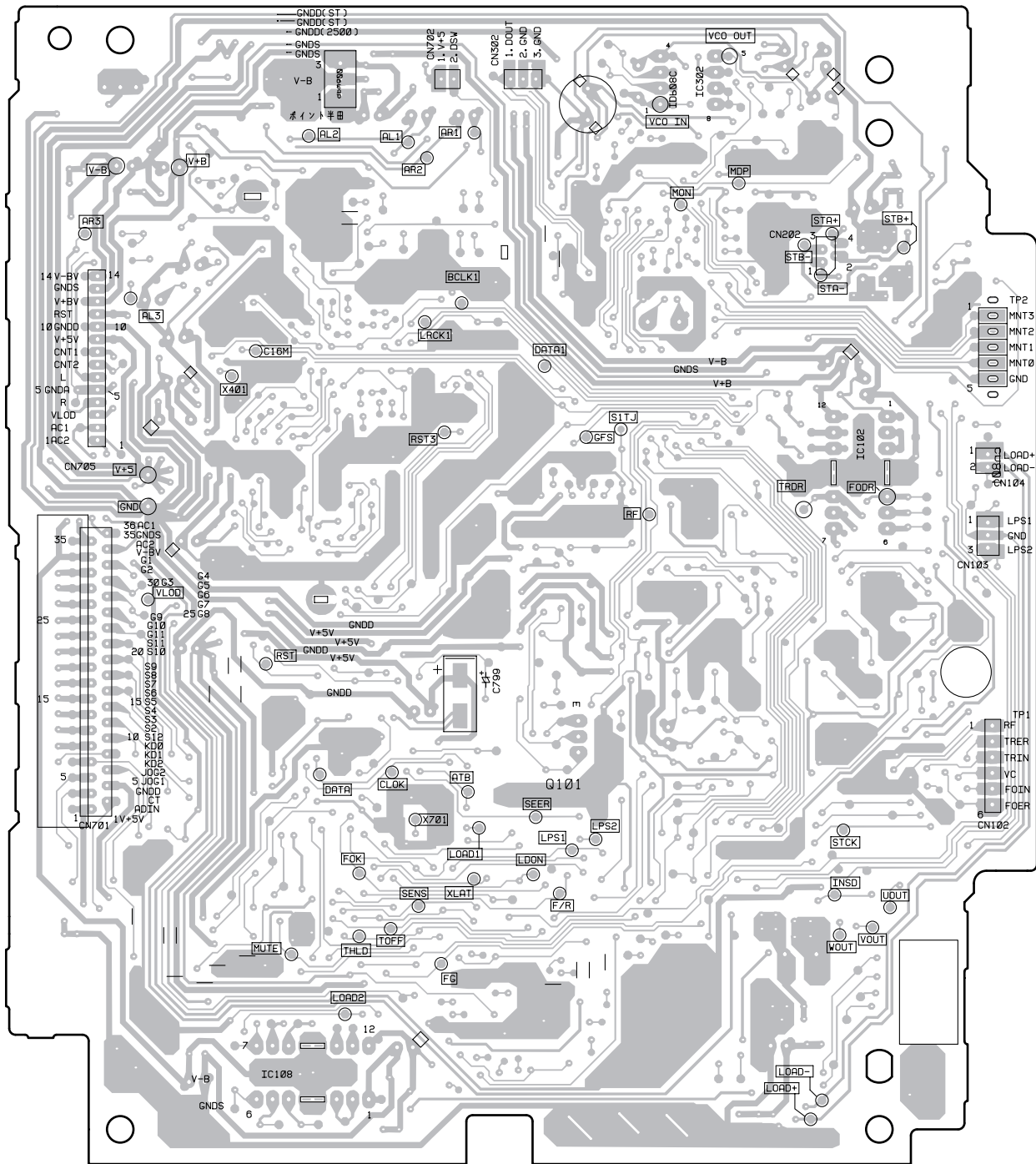

4.2 DISPLAY BOARD ASSEMBLY

D DISPLAY BOARD ASSY

SIDE A

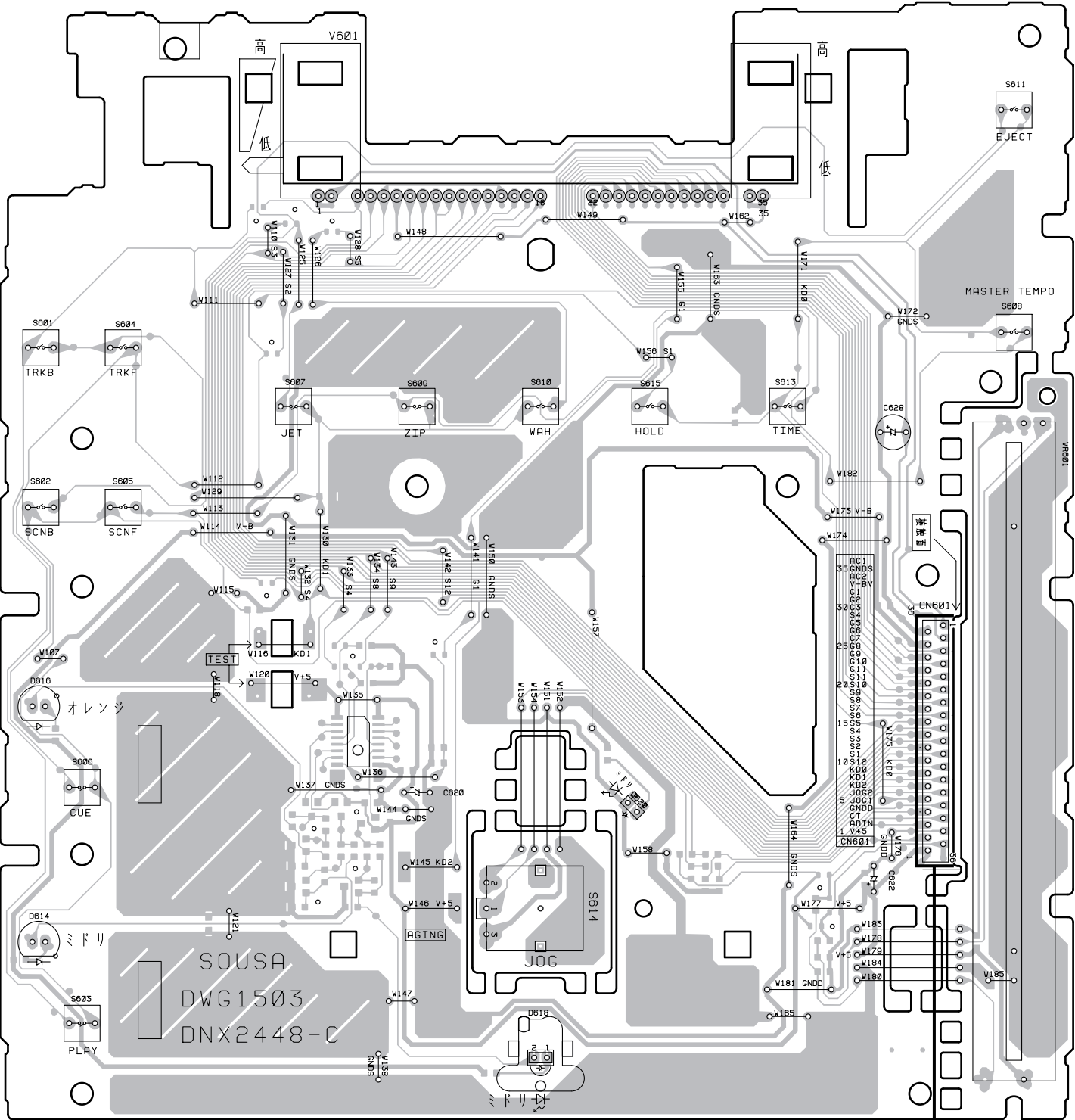

(DNP1873-C)

B CN701

VR601

D DISPLAY BOARD ASSY

SIDE B

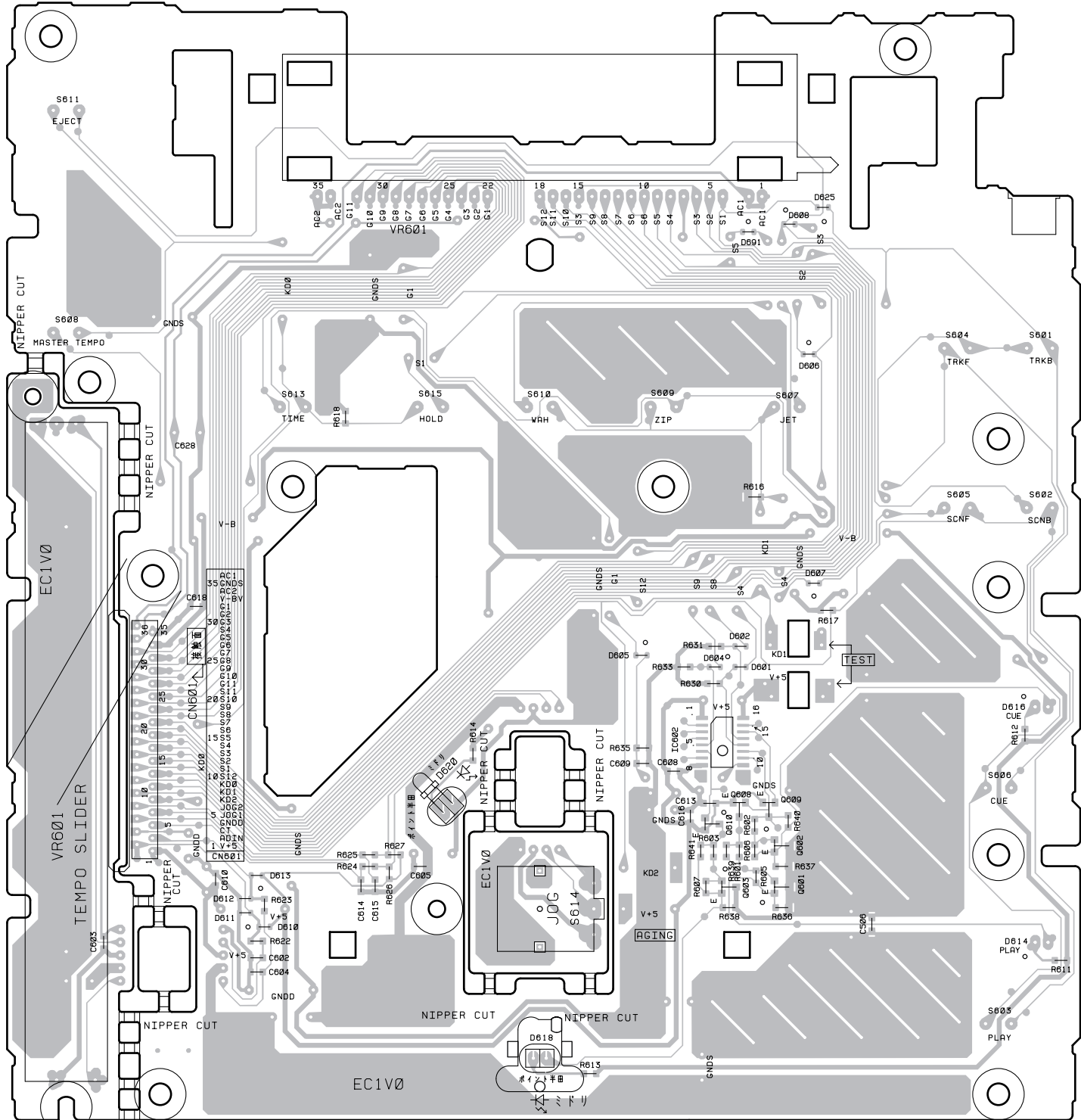

(DNP1873-C)

- IC602
- Q608 Q609
- Q610 Q602
- Q603 Q601

5. PCB PARTS LIST

- NOTES :
- Parts marked by “NSP” are generally unavailable because they are not in our Master Spare Parts List.
 - The \triangle mark found on some component parts indicates the importance of the safety factor of the part. Therefore, when replacing, be sure to use parts of identical designation.
 - When ordering resistors, first convert resistance values into code form as shown in the following examples.
- Ex. 1 When there are 2 effective digits (any digit apart from 0), such as 560 ohm and 47k ohm (tolerance is shown by $J = 5\%$, and $K = 10\%$).
- 560 $\Omega \rightarrow 56 \times 10^1 \rightarrow 561$ RD1/4PU $\begin{matrix} 5 & 6 & 1 \\ \hline & & J \end{matrix}$
- 47k $\Omega \rightarrow 47 \times 10^3 \rightarrow 473$ RD1/4PU $\begin{matrix} 4 & 7 & 3 \\ \hline & & J \end{matrix}$
- 0.5 $\Omega \rightarrow R50$ RN2H $\begin{matrix} R & 5 & 0 \\ \hline & & K \end{matrix}$
- 1 $\Omega \rightarrow 1R0$ RS1P $\begin{matrix} 1 & R & 0 \\ \hline & & K \end{matrix}$
- Ex. 2 When there are 3 effective digits (such as in high precision metal film resistors).
- 5.62k $\Omega \rightarrow 562 \times 10^1 \rightarrow 5621$ RN1/4PC $\begin{matrix} 5 & 6 & 2 & 1 \\ \hline & & & F \end{matrix}$

■ LIST OF WHOLE PCB ASSEMBLIES

Mark	Symbol and Description	Part No.			Remarks
		KUC type	RL type	WY type	
NSP	MOTHER BOARD ASSY	DWM2078	DWM2079	DWM2079	
	SUB BOARD ASSY	DWX1892	DWX1891	DWX1898	
	— DISPLAY BOARD ASSY	DWG1503	DWG1503	DWG1503	
	— TRANS BOARD ASSY	DWR1298	DWR1301	DWR1300	
NSP	— SL MECHA BOARD ASSY	DWS1294	DWS1294	DWS1294	
NSP	— DIGITAL OUT BOARD ASSY	DWZ1082	Not used	Not used	

■ CONTRAST OF PCB ASSEMBLIES

B MOTHER BOARD ASSY

DWM2078 and DWM2079 are constructed the same except for the following:

Mark	Symbol and Description	Part No.		Remarks
		DWM2078	DWM2079	
	C709	CKSQYB103K50	Not used	
	C719, C720	CKSQYB104K25	Not used	
	R319	RS1/10S561J	Not used	
	R708	Not used	RS1/10S223J	
	R738	RS1/10S102J	Not used	
	CN302	S3B-PH-K-Y	Not used	
CN702	S2B-PH-K-Y	Not used		

C TRANS BOARD ASSY

DWR1298, DWR1301 and DWR1300 are constructed the same except for the following:

Mark	Symbol and Description	Part No.			Remarks
		DWR1298	DWR1301	DWR1300	
	S2 Voltage Selector	Not used	DSA1026	Not used	

■ PARTS LIST FOR CDJ-100S/KUC

Mark	No.	Description	Part No.	Mark	No.	Description	Part No.
B MOTHER BOARD ASSY							
SEMICONDUCTORS							
	IC201		BA6849FP		C157-C159, C161, C162		CKSQYB104K25
	IC302		BA7042		C171, C172, C181, C189		CKSQYB104K25
	IC101		CXA1782CQ		C193-C195, C202, C206-C210		CKSQYB104K25
	IC301		CXD2500BQ		C212, C218, C314, C319		CKSQYB104K25
	IC102, IC108		LA6520		C351-C354, C402, C406		CKSQYB104K25
	IC402		MB814800-70PJ		C408-C412, C416, C433, C434		CKSQYB104K25
	IC401		MN19413A-P		C481, C482, C701, C704, C706		CKSQYB104K25
	IC206		MPC17A85ZVM		C713, C717, C719, C720		CKSQYB104K25
	IC103, IC106		NJM2068M		C901, C902, C94		CKSQYB104K25
	IC104, IC901, IC902		NJM2904M		C907		CKSQYB105K10
	IC203, IC405		NJM4558MD		C711, C712		CKSQYB122K50
	IC701		PD4977B		C313		CKSQYB152K50
	IC107		TC4W53F		C106, C173, C311		CKSQYB222K50
	IC105		TC4W66F		C163, C903, C904		CKSQYB224K16
	IC110		TC7S00F		C225		CKSQYB332K50
	IC303		TC7SU04F		C122		CKSQYB333K50
	Q102		2SA1163		C111		CKSQYB473K25
	Q101		2SA1515		C101, C312, C703		CKSQYB473K50
	Q103, Q401, Q402, Q405, Q406		2SD2114K		C129, C174, C308		CKSQYB474K16
	Q403		DTC124EK		C125		CKSQYB562K50
	D712, D713, D729, D730		1SS355		C117, C153		CKSQYB682K50
	D735-D738, D901-D904		1SS355		C127		CKSQYB683K25
					C201 (100 μ F/16V)		DCH1105
					C93 (330 μ F/ 16V)		DCH1108
					C306 (470 μ F/ 10V)		DCH1109
					C109, C124, C126, C130		DCH1110
					(100 μ F/6.3V)		
					C114 (47 μ F/6.3V)		DCH1111
					VC301 (40 pF)		VCM1010
COILS AND FILTERS				RESISTORS			
	L201 (39 μ H)		DTL1070		R403, R404 (82 Ω)		ACN7049
	L401		LFA220J		R223, R224 (1.6 Ω , 1/4W)		DCN1109
Δ	L309, L310		VTL1105		R201 (1.8 Ω , 1/4W)		DCN1120
					R461, R462		RN1/10SE2202D
					R206, R207		RS1/10S1002F
					R142-R144, R146, R191-R194		RS1/10S1503F
					R108		RS1/10S2403F
					VR101-VR104 (22 k Ω)		VCP1174
					Other Resistors		RS1/10S <input type="checkbox"/> <input type="checkbox"/> <input type="checkbox"/> <input type="checkbox"/> J
CAPACITORS				OTHERS			
	C304, C305, C445, C446		CCSQCH150J50		CN201 CONNECTOR (15P)		52207-1590
	C309		CCSQCH221J50		CN101 CONNECTOR (17P)		52207-1790
	C148		CCSQCH240J50		CN104 CONNECTOR POST (2P)		B2B-PH-K-S
	C115		CCSQCH270J50		CN103 CONNECTOR POST (3P)		B3B-PH-K-S
	C453-C456		CCSQCH390J50		CN102 TOP POST (6P)		B6P-SHF-1AA
	C451, C452		CCSQCH471J50		P.C. BOARD		DNP1872
	C121		CCSQCH680J50		(20 MHz)		DSS1104
	C705, C714		CEAL101M6R3		X701 (4.19 MHz)		DSS1105
	C191, C192		CEAL330M25		CN701 FFC CONNECTOR 36P		HLEM36R-1
	C315, C415		CEAL470M6R3		X301 (16.9344 MHz)		PSS1008
	C107		CEAL4R7M16		CN202 FFC CONNECTOR 4P		VKN1235
	C91, C92		CEJA101M16				
	C219, C318, C401		CEJA101M6R3				
	C404		CEJA1R0M50				
	C405, C407, C463, C464		CEJA220M25				
	C119, C120		CEJA330M25				
	C316		CEJA3R3M50				
	C317		CFTLA474J50				
	C110, C116, C320		CKSQYB102K50				
	C104, C112, C118, C132, C133		CKSQYB103K50				
	C141, C188, C213, C220-C224		CKSQYB103K50				
	C231, C301, C307, C403, C421		CKSQYB103K50				
	C702, C709, C905		CKSQYB103K50				
	C102, C103, C105, C108, C113		CKSQYB104K25				
	C128, C135, C137, C151, C152		CKSQYB104K25				

CDJ-100S

Mark No.	Description	Part No.
----------	-------------	----------

D DISPLAY BOARD ASSY

SEMICONDUCTORS

IC602	HD74HC175FP
Q601-Q603	2SC2412K
Q608-Q610	PDTA124EK
D601, D602, D604-D608	1SS355
D610-D613, D625, D691	1SS355
D620	GL3EG43
D618	MPG4361F
D614	SLP3118C51H
D616	SLP4118C51H

SWITCHES AND RELAYS

S603, S606	DSG1063
S614	DSX1051
S601, S602, S604, S605	VSG1008
S607-S611, S613, S615	VSG1008

CAPACITORS

C628	CEJA220M50
C602-C604, C609, C614, C615	CKSQYB103K50
C608, C610, C613, C616, C618	CKSQYB104K25

RESISTORS

VR601 (10 kΩ-B)	DCV1009
Other Resistors	RS1/10S □□□J

OTHERS

CN601	FFC CONNECTOR 36P	52492-3620
	FL HOLDER	DEB1396
V601	FL INDICATOR TUBE	DEL1031

C TRANS BOARD ASSY

SEMICONDUCTORS

△ IC92	ICP-N10
△ IC91	ICP-N25
△ IC23	PQ05RR12
△ Q1	2SB1566
△ D11-D14, D52	11E2 (TB2)
D502	1SS355
D54	MTZJ27A
D55	MTZJ33B

COILS AND FILTERS

△ L1	VTL-004
△ L501, L502	VTL1105

SWITCHES AND RELAYS

△ S1	RSA1001
------	---------

CAPACITORS

△ C1-C3 (10000 pF/AC250V)	ACG7020
C25	CEAT102M16
C21	CEAT103M16
C55	CEAT220M50
C52, C54	CEAT221M50

Mark No.	Description	Part No.
----------	-------------	----------

C32	CEAT471M6R3
C12, C23, C24, C591, C83	CKSQYB104K25
C505	CKSQYF103Z50
C11, C13-C17, C56	CKSQYF104Z50
C501, C502	CQMA152J50

RESISTORS

R60	RD1/4VM222J
R551	RD1/4VM271J
Other Resistors	RS1/10S □□□J

OTHERS

J11	14P PARALLEL WIRE	D20PWY1420E
	HEAT SINK	DNG1077
△ JA501	PIN JACK 2P	RKB1041
	TERMINAL 2P	RKC-061
△ JA502	JACK (REMOTE)	RKN1004
H1, H2	FUSE HOLDER	RKR1003
	PCB BINDER	VEF1040

A SL MECHA BOARD ASSY

SWITCHES AND RELAYS

S901, S902	DSG1017
------------	---------

OTHERS

CN901	KR CONNECTOR 3P	S3B-PH-K-S
-------	-----------------	------------

E DIGITAL OUT BOARD ASSY

SEMICONDUCTORS

IC801	TC74HCU04AF
-------	-------------

COILS AND FILTERS

L801	PTL1003
------	---------

SWITCHES AND RELAYS

S801	VSH1009
------	---------

CAPACITORS

C806	CEJA101M6R3
C805	CEJA470M35
C804, C807	CKSQYB103K50
C801, C808, C809	CKSQYB104K25

RESISTORS

All Resistors	RS1/10S □□□J
---------------	--------------





OTHERS

JA801	PIN JACK 1P	PKB1028
-------	-------------	---------

6. ADJUSTMENT

6.1 PREPARATIONS

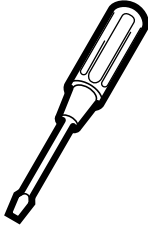
6.1.1 Jigs and Measuring Instruments

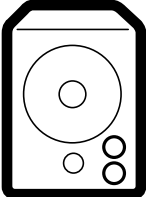
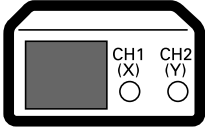
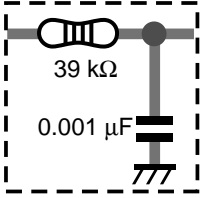
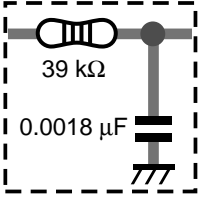
 <p>8-cm DISC (With at least about 20 minutes recording)</p>	 <p>CD TEST DISC</p>	 <p>⊖ Precise screwdriver</p>	 <p>⊖ screwdriver (small)</p>	 <p>⊕ screwdriver (medium)</p>
 <p>⊕ screwdriver (large)</p>	 <p>Low-frequency oscillator</p>	 <p>Dual-trace oscilloscope (10 : 1 probe)</p>	 <p>Low pass filter ① (39 kΩ + 0.001 μF)</p>	 <p>Low pass filter ② (39 kΩ + 0.0018 μF)</p>

6.1.2 Necessary Adjustment Points

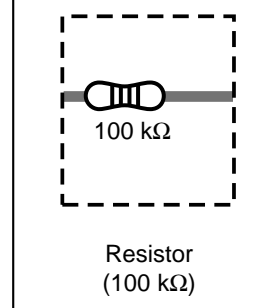
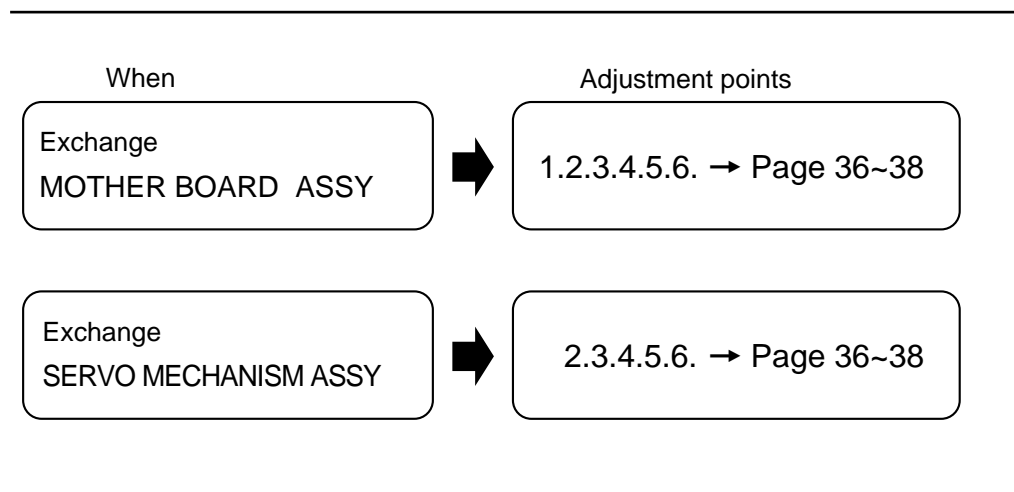

6.2 ADJUSTMENT

6.2.1 How to Start/Cancel Test Mode

[Precautions for Test Mode]

- (1) If a soiled or damaged disc is played back and a GFS error is generated, the system may not perform a STOP operation and may run out of control, although muting ON/OFF will be performed. If the system does run out of control, press the CUE key to switch the power OFF.
- (2) Do NOT press any key while an OPEN/CLAMP, SPINDLE KICK, or FOCUS SEARCH operation is in progress. Be sure to wait until the operation is completed before calling the next operation.

TEST MODE : ON

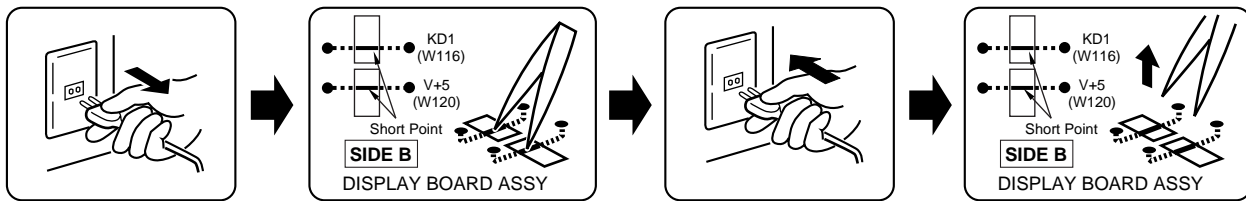

TEST MODE : PLAY

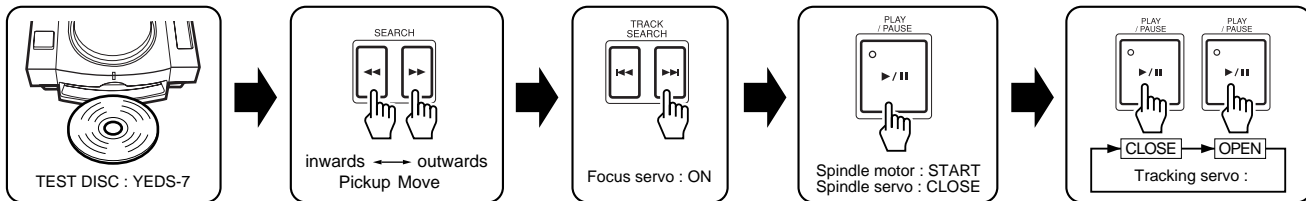

TEST MODE : DISPLAY

Switch Status Display

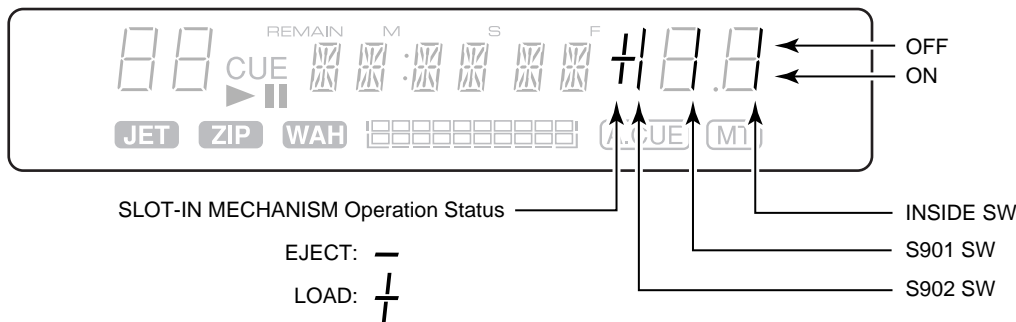

TEST MODE : STOP → CANCEL

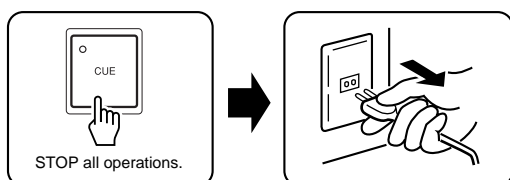

6.2.2 Test Mode Key Locations

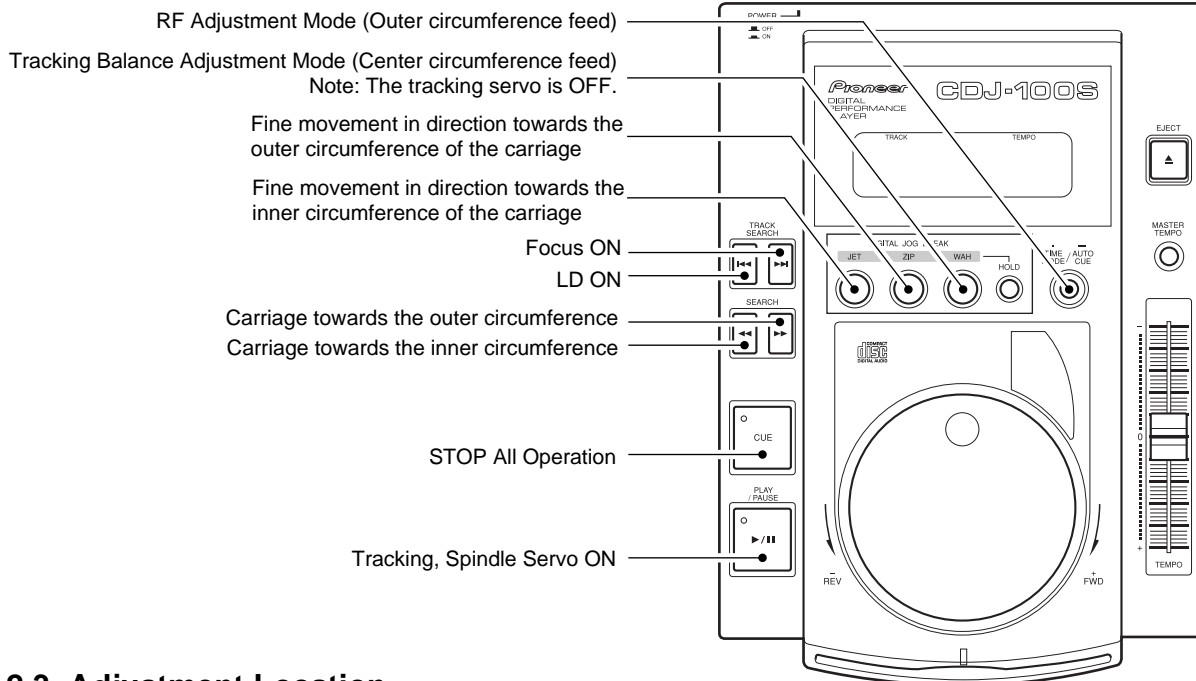

6.2.3 Adjustment Location

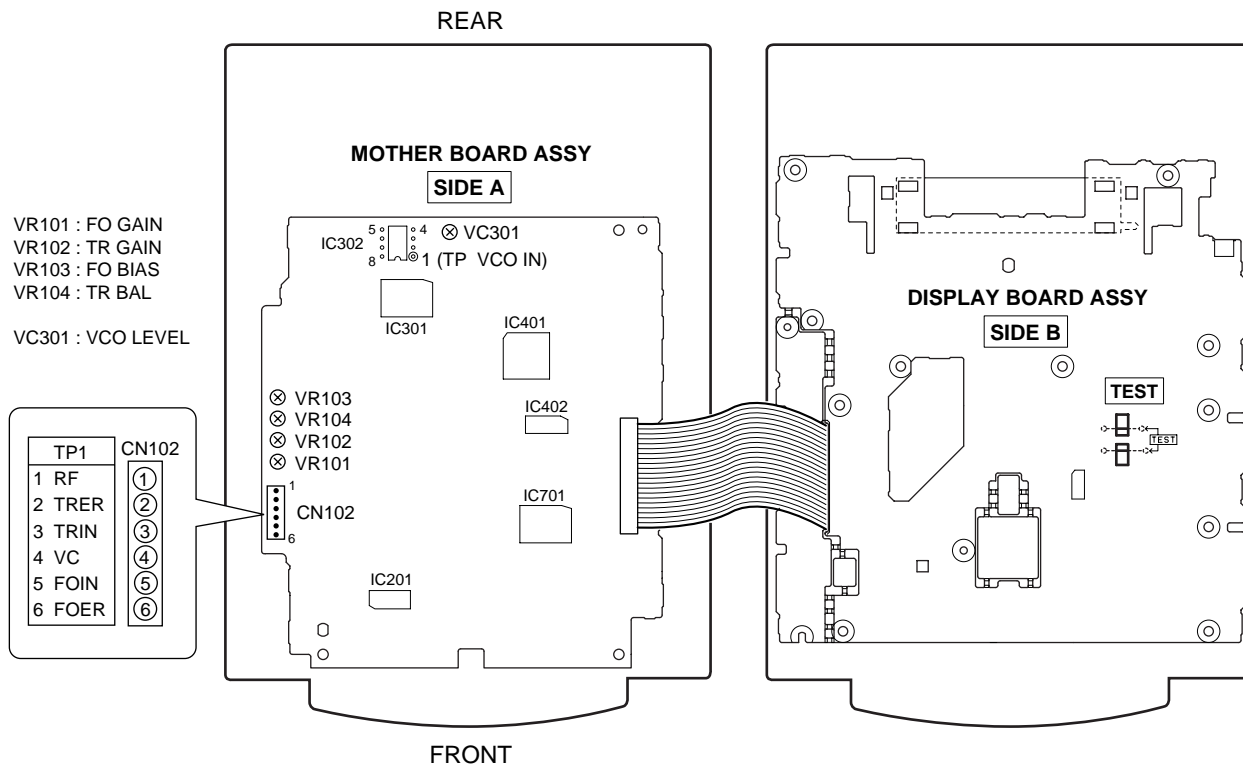

6.2.4 Check and Adjustment

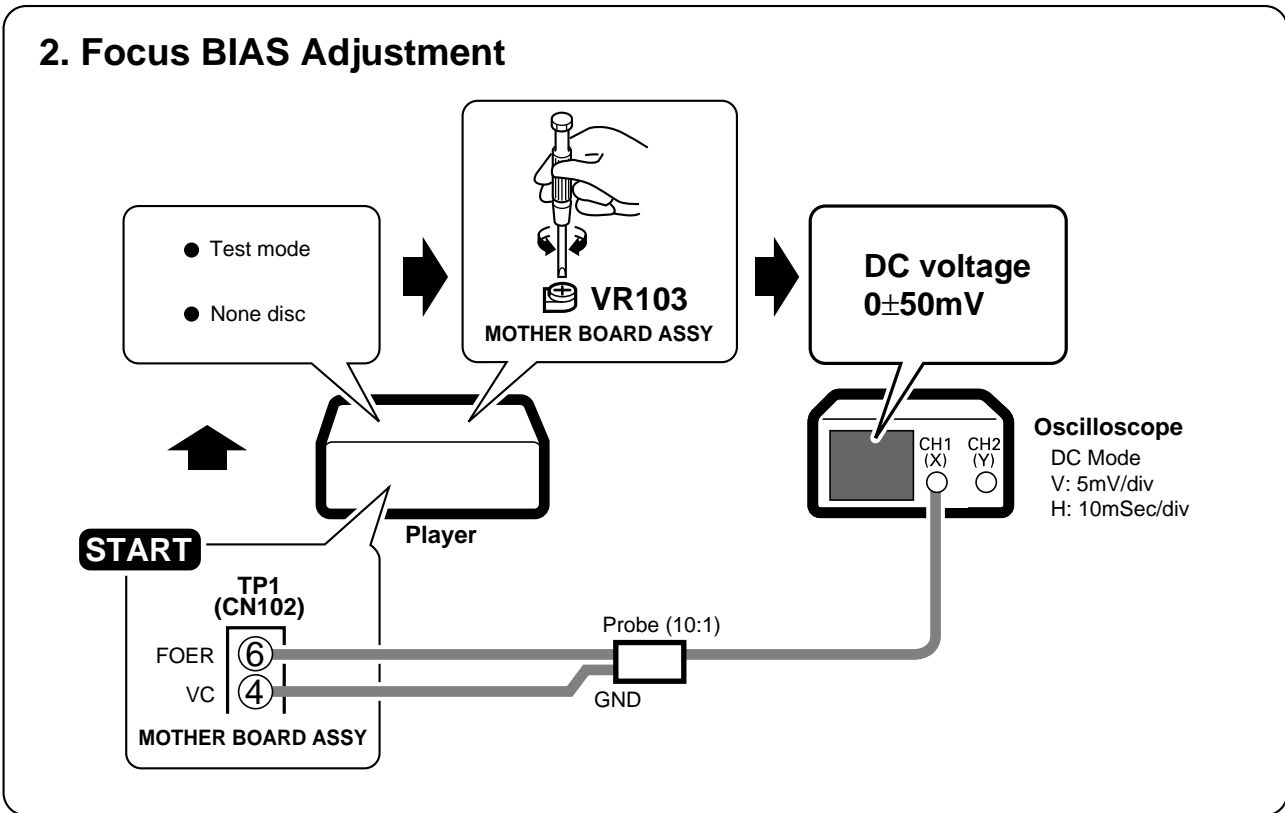
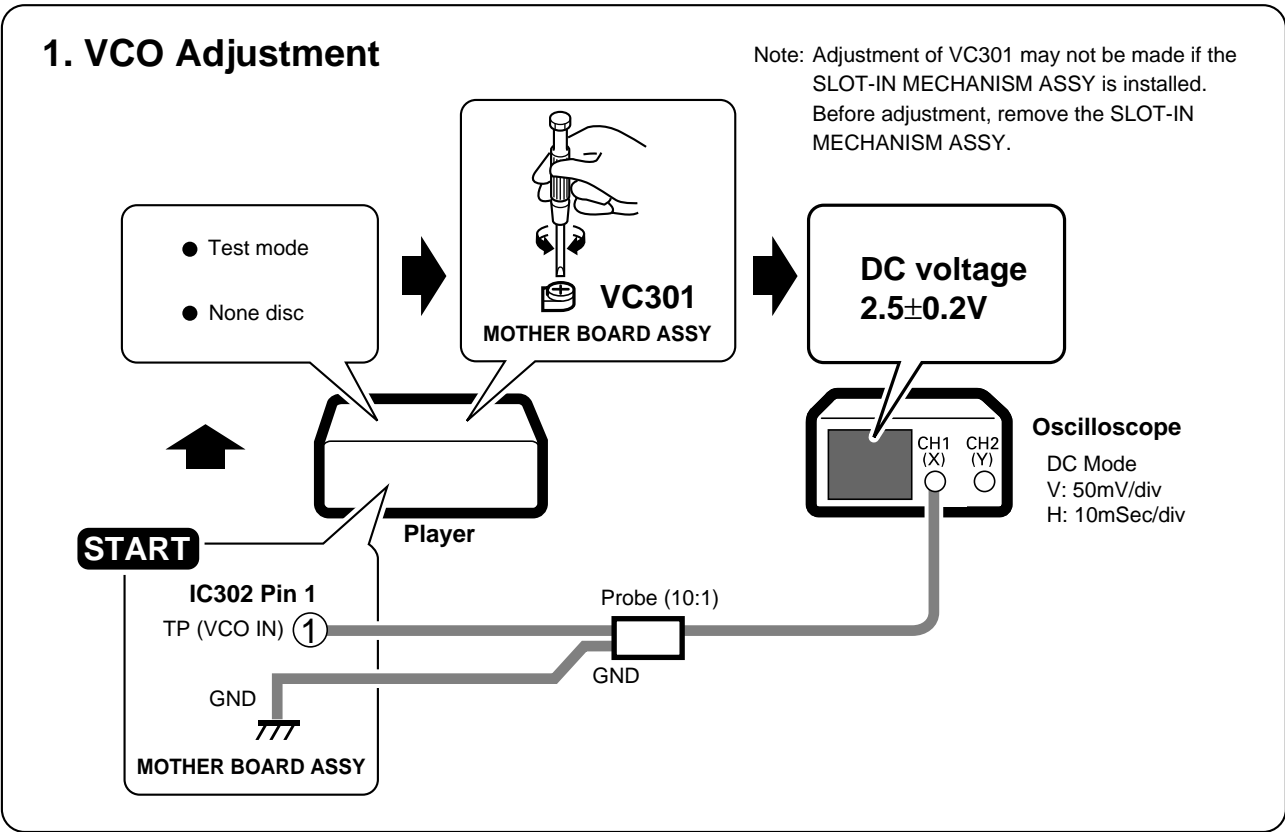

3. Tracking Error Barance Adjustment

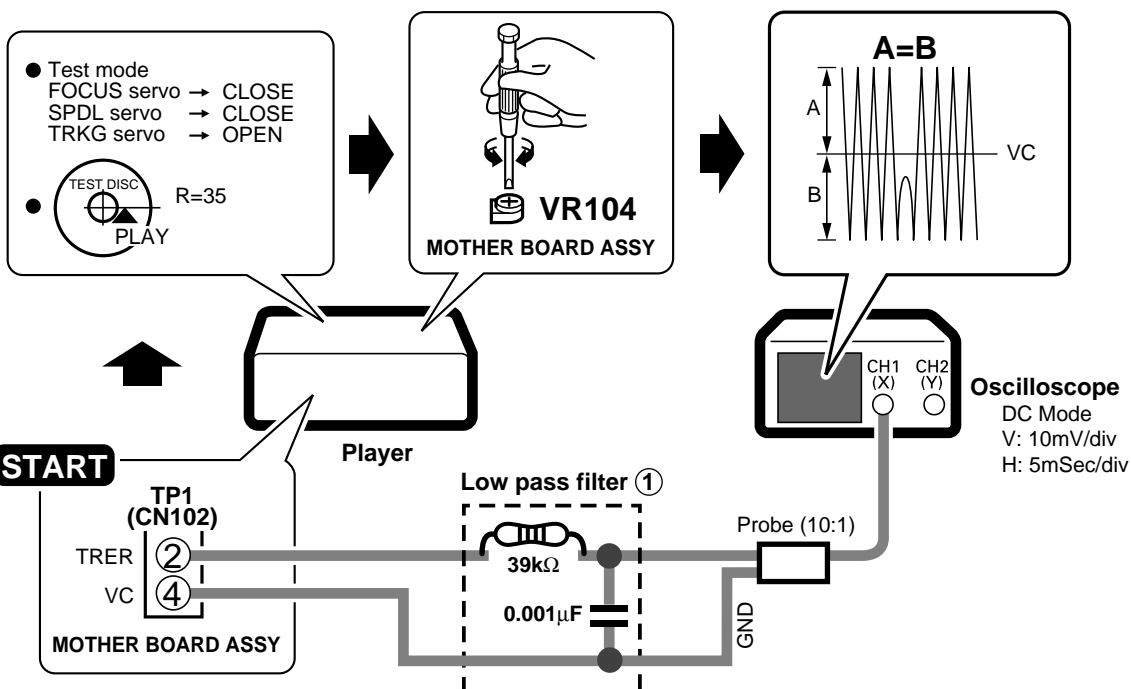

4. RF Level Adjustment

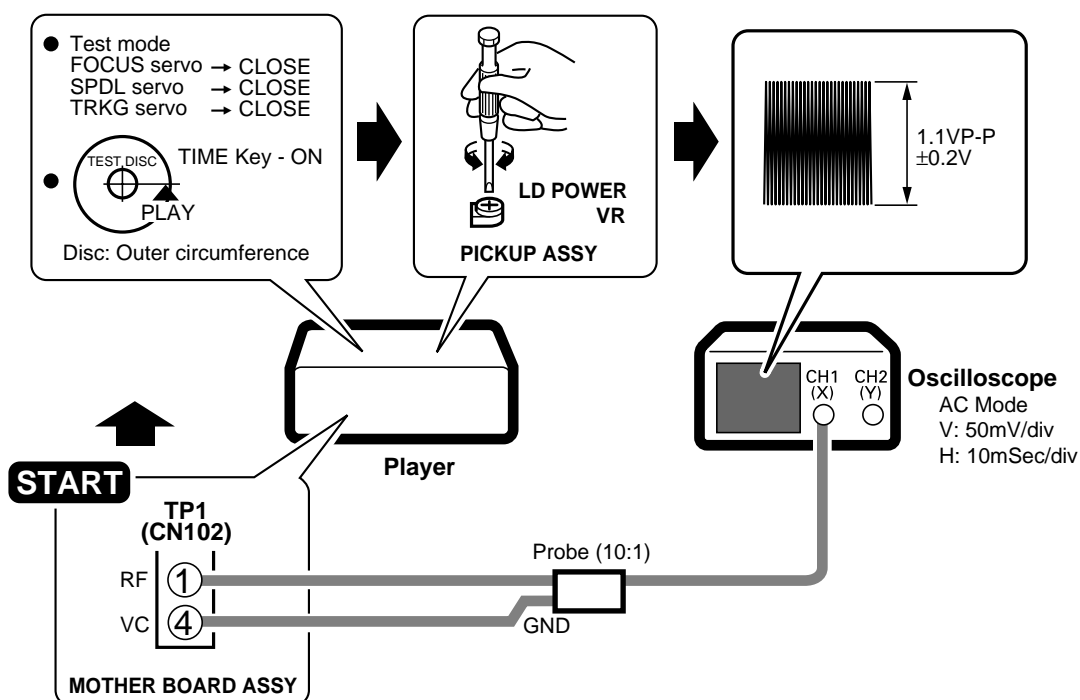

5. Focus Servo Loop Gain Adjustment

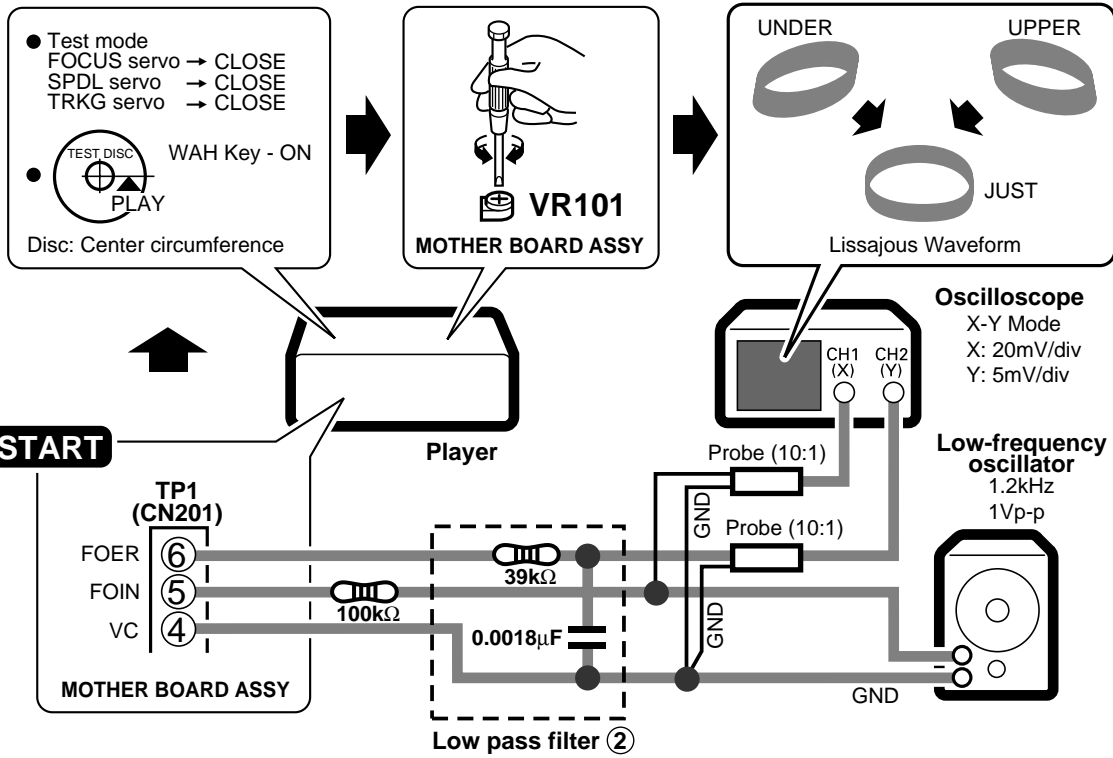

6. Tracking Servo Loop Gain Adjustment

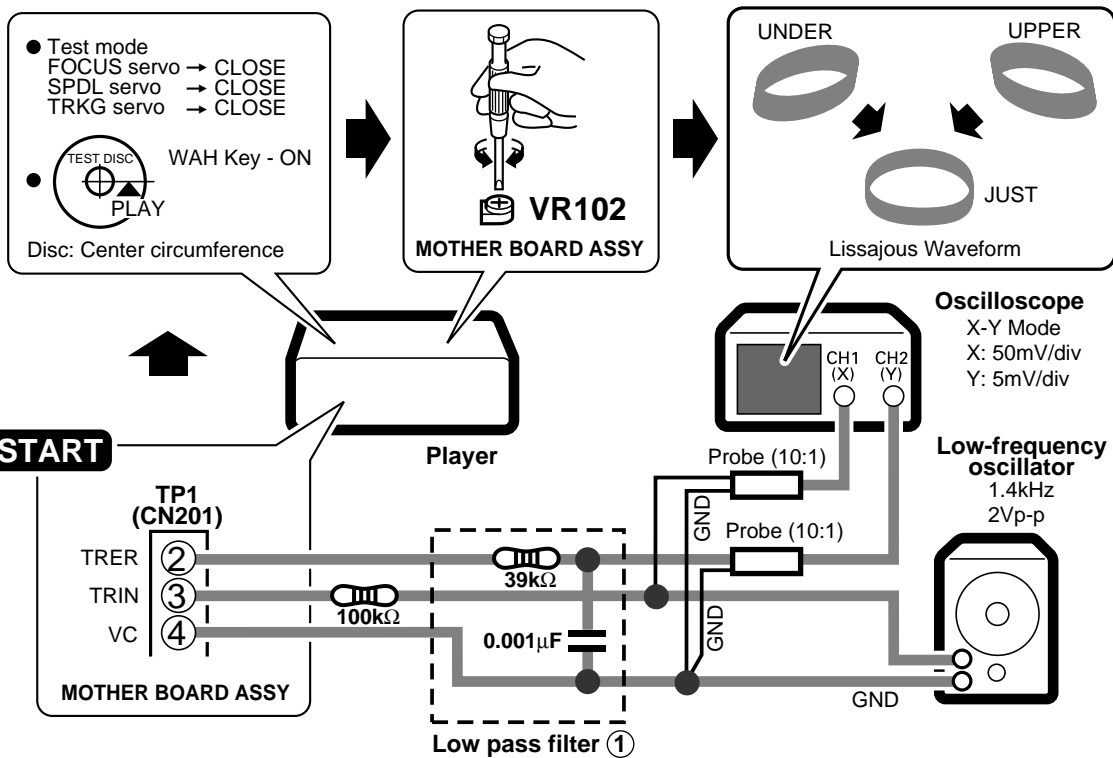

7. GENERAL INFORMATION

7.1 PARTS

7.1.1 IC

■ PD4977B (IC701: MOTHER BOARD ASSY)

● System Control Micro-computer

● The information shown in the list is basic information and may not correspond exactly to that shown in the schematic diagrams.

● Pin Assignment (Top view)

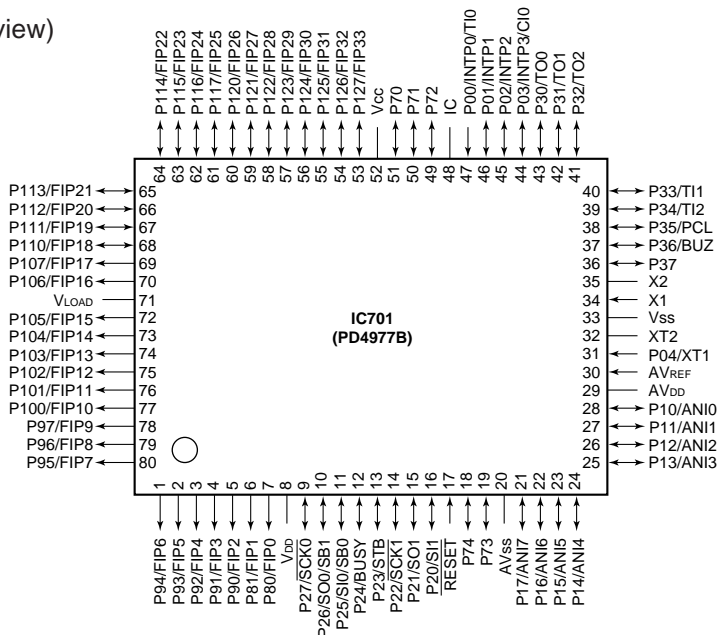

● Block Diagram

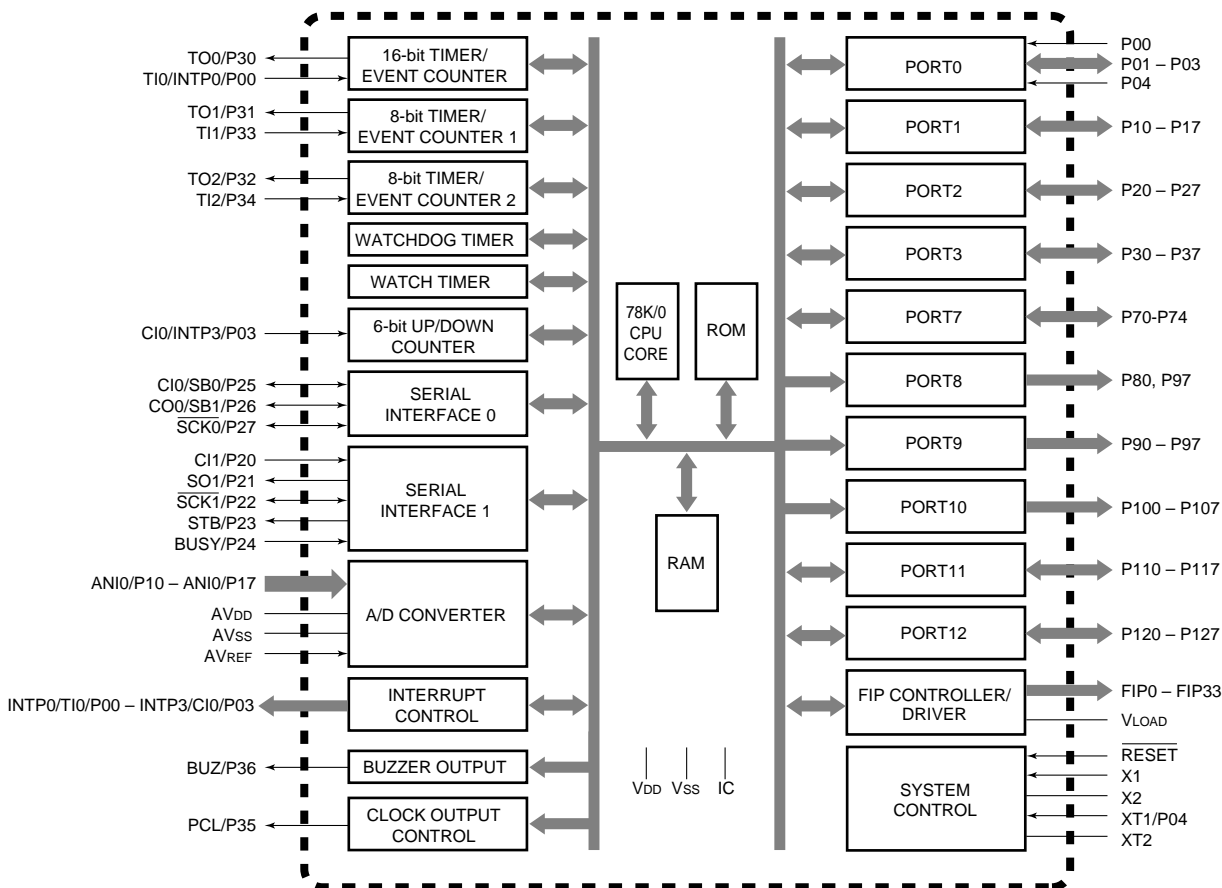

● Pin Function

No.	Name	I/O	Description
1 7	GRID 7 GRID 1	O	FL grid output 7 FL grid output 1
8	VDD	—	Connected to VDD.
9	CNT2	I	External control input
10	CNT1	I/O	External control input/output
11	DSPS	I	DSP memory sampling. (During sampling: H)
12	P0	O	Not used
13	INT1	O	
14	CLOCK	O	Serial clock [for IC301 (CXD2500BQ)]
15	DATA	O	Serial data output [for IC301 (CXD2500BQ)]
16	SQSO	I	Sub-code Q serial data input.
17	RST	I	CPU reset. (L : reset)
18	DSPC	I	DSP data compare input. (H: comparing)
19	DPDT	I/O	DSP data output
20	GND ref	—	Ground potential for the A/D converter.
21	RST3	O	DSP reset output (L : reset)
22	DPCK	O	DSP clock output
23	MD2	O	IC301 (CXD2500BQ) Digital out control terminal (L: OFF, H: ON)
24	INT0	O	Not used
25	ATB	I	A/D input for ATB. (above 0.5 V : ATB, below : no ATB)
26	SERR	I	A/D input to control the stepping motor.
27	CT	I	Slider center tap voltage input.
28	ADIN	I	Slider voltage input.
29	VDD	—	Analog power for the A/D converter.
30	VDD ref	—	Standard voltage input for the A/D converter.
31	FCOK	I	Focus OK input. (H : OK, L : NG)
32	XT2	—	Not used
33	GND	—	Connected to GND.
34	X1	—	Oscillator pulses for the main system. (4.194304 MHz)
35	X2	—	
36	LPS1	I	Load position SW1 input (Switch ON: L/ OFF: H)
37	LOAD2	I/O	Slot-in motor output 2
38	S1TJ	O	Servo control output (1 Track Jump: H)
39	LOAD	I/O	Slot-in motor output 2
40	GFS	I	Frame sync lock input. (H : OK, L : NG)

No.	Name	I/O	Description
41	STCK	O	Stepping motor control output
42	XLAT	O	LSI control data latch pulse
43	LDON	O	Laser diode output (L: OFF, H: ON)
44	PALS	I	Interrupt input for RAM-internal display pulses.
45	FG	I	FG pulse input
46	SCOR	I	Interrupt input for sub-code sync
47	JOG1	I	Interrupt input for jog dial pulses
48	IC	—	Connected to GND.
49	F/R	O	Stepping motor forward/reverse output
50	ATSQ	O	Auto focus output (During auto focus: H)
51	INSD	I	Slider inside switch input. (L : inside)
52	VDD	O	Connected to VDD.
53	SENS	I	LSI operation status input
54	TOFF	O	Switching analog switch output (Tracking ON/OFF: H/L, Track count search: H)
55	THOLD	O	Switching analog switch output (1, 10 and 100 track jump: H)
56	MUTE	O	Muting output (L: ON, H: OFF)
57	JOG2	I	Jog dial pulse input
58 60	KD2 KD0	I	Key-scan data input
61	DSW	I	Digital out ON/OFF input switch (L: ON, H: OFF)
62	LPS2	I	Load position SW2 input (Switch ON: L/ OFF: H)
63	SEG12	O	FL segment output 12
64 70	SEG1 SEG7	O	FL segment output 1 FL segment output 7
71	VLOAD	—	Connected to FIP controller/driver pull-down resistance. (-31V)
72 75	SEG8 SEG11	O	FL segment output 8 FL segment output 11
76	NC	O	Not used
77 80	GRID11 GRID8	O	FL grid output 11 FL grid output 8

7.1.2 DISPLAY

■ DEL1031 (V601: DISPLAY BOARD ASSY)

- FL Tube
- Pin Assignment

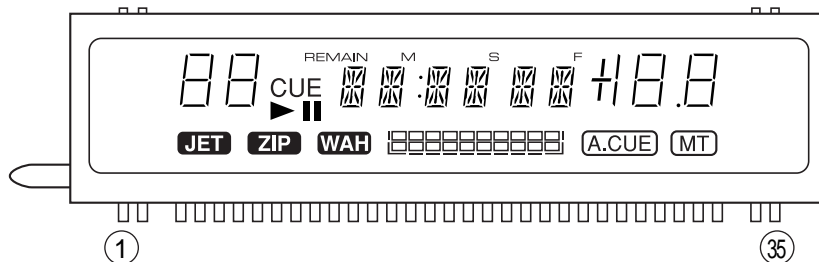

Note) F1, F2: Filament G1 to G11: Grid
 S1 to S15: Anode NP: No pin
 NL: No Lead

● Pin Connection

Pin No.	1	2	3	4	5	6	7	8	9	10	11	12	13	14	15	16	17	18	19	20	21	22	23	24	25	26	27	28	29	30	31	32	33	34	35
Assignment	F1	F1	NP	S1	S2	S3	S4	S5	S6	S7	S8	S9	S10	S11	S12	S13	S14	S15	NL	NL	NL	G1	G2	G3	G4	G5	G6	G7	G8	G9	G10	G11	NP	F2	F2

● Anode and Grid Assignment (1/2)

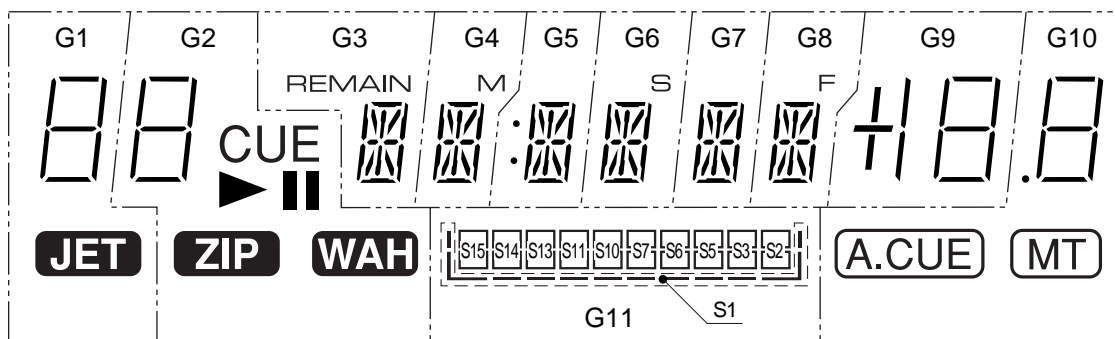

● Anode and Grid Assignment (2/2)

	G1	G2	G3	G4	G5	G6	G7	G8	G9	G10	G11
S1	S1	S1	S1	S1	S1	S1	S1	S1	S1	S1	S1
S2	S2	S2	S2	S2	S2	S2	S2	S2	S2	S2	S2
S3	JET	WAH	S3	S3	S3	S3	S3	S3			S3
S4			S4	S4	S4	S4	S4	S4			
S5		ZIP	S5	S5	S5	S5	S5	S5	S5	S5	S5
S6	S6	S6	S6	S6	S6	S6	S6	S6	S6	S6	S6
S7	S7	S7	S7	S7	S7	S7	S7	S7	S7	S7	S7
S8			S8	S8	S8	S8	S8	S8			
S9	S9	S9	S9	S9	S9	S9	S9	S9	S9	S9	
S10		CUE	S10	S10	S10	S10	S10	S10	S10	A.CUE	S10
S11			S11	S11	S11	S11	S11	S11	S11	MT	S11
S12			S12	S12	S12	S12	S12	S12			
S13	S13	S13	S13	S13	S13	S13	S13	S13	S13	S13	S13
S14	S14	S14	S14	S14	S14	S14	S14	S14	S14	S14	S14
S15		▶	REMAIN	M	S15	S		F			S15

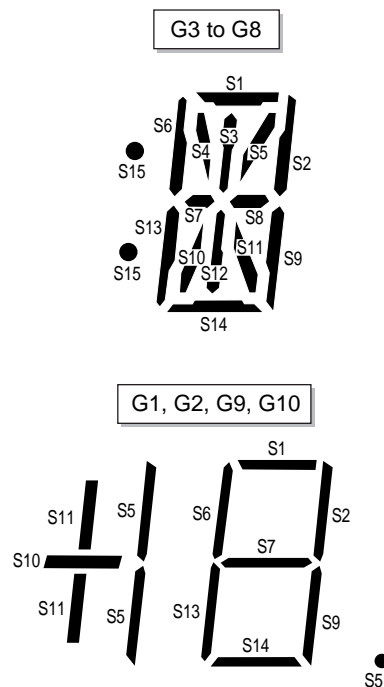

7.2 DIAGNOSIS

7.2.1 ERROR DISPLAY

When the player detects an error during operation, it will immediately stop and display an error code in the display window.

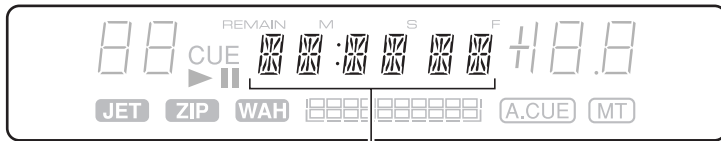

Error Code Number

Displayed Error Code Number	Type of Error	Error Contents	Possible Cause → Remedy
E - 7201	TOC READ ERROR	TOC date cannot be read after 20 seconds.	The disc is soiled.
E - 7202	FG PULSE ERROR	Disc is rotating, but rotation cannot be ascertained.	Either IC201 (spindle driver IC) or Pin 45 of IC701 (system control micro-computer) is damaged.
E - 8301	PLAYER ERROR	Disc loaded cannot be played properly (GFS NG).	<ul style="list-style-type: none"> The disc is soiled. The disc is scarred.
E - 8302	PLAYER ERROR	Disc loaded cannot be played properly (FOCUS NG)	<ul style="list-style-type: none"> The disc is soiled. The disc is scarred.
E - 9101	S901 SW MECHANICAL ERROR	The servo mechanism is not clamped even after the max. operation time has passed.	<ul style="list-style-type: none"> The slot-in mechanism is defective. S901 SW is damaged.
E - 9103	MECHANICAL TIME OUT	The pickup does not return to the inside even after the max. operation time has passed. (INSIDE: 5s)	The servo mechanism is defective.

7.2.2 DISASSEMBLY

<< PRECAUTIONS >>

Be sure to disconnect the power cable from the AC outlet whenever removing the card flexible cable from the connector for maintenance, etc. Hold the both sides of the card flexible cable with both hands to disconnect the cable straight. (Even if the power has been switched OFF, previously charged voltage may remain in the capacitor, etc. If the electrodes of the card flexible cable and those of the connector come in contact by accident, a malfunction may occur.)

■ Removal of the Servo Mechanism Assy

- ① Remove the five screws (A) at the bottom of the body.
- ② Open the top panel part as shown in the figure.

Note: Perform the work after spreading a cloth or similar to prevent damage to the top panel.

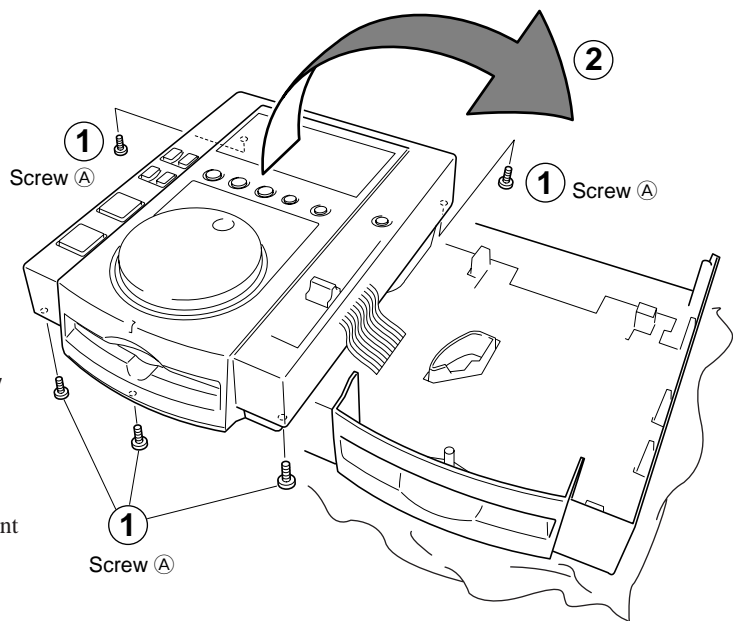

- ③ Remove the binder, the card flexible cable (36P FFC/60V), and the top panel part.
- ④ Disconnect the earth lead unit.

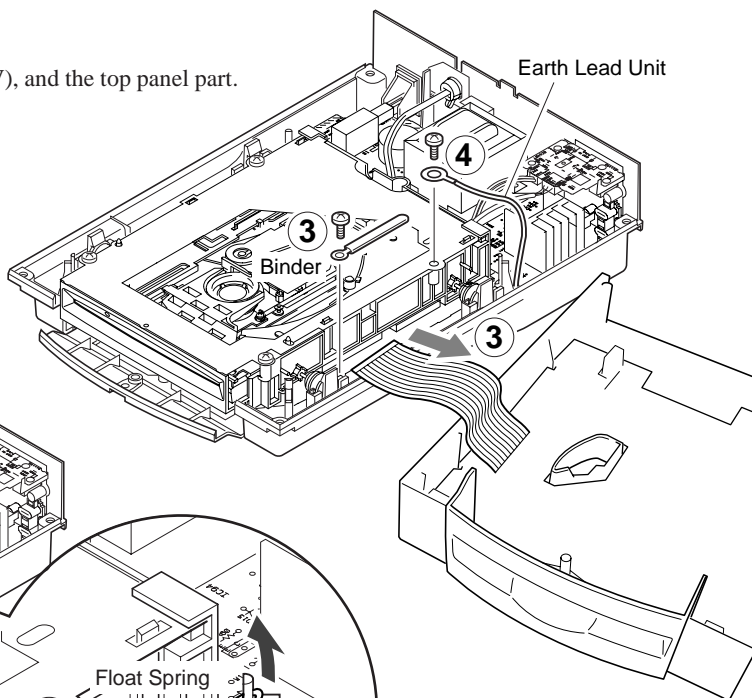

- ⑤ Remove the four float springs.

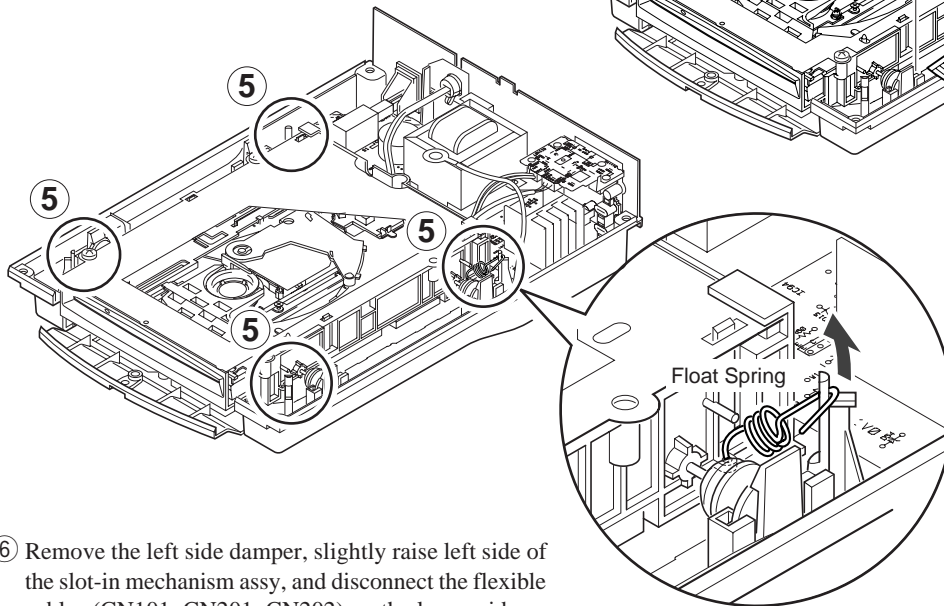

- ⑥ Remove the left side damper, slightly raise left side of the slot-in mechanism assy, and disconnect the flexible cables (CN101, CN201, CN202) on the lower side.
- ⑦ Disconnect the connectors (CN103, CN104), and slide the slot-in mechanism assy to the side on which the damper has been removed.

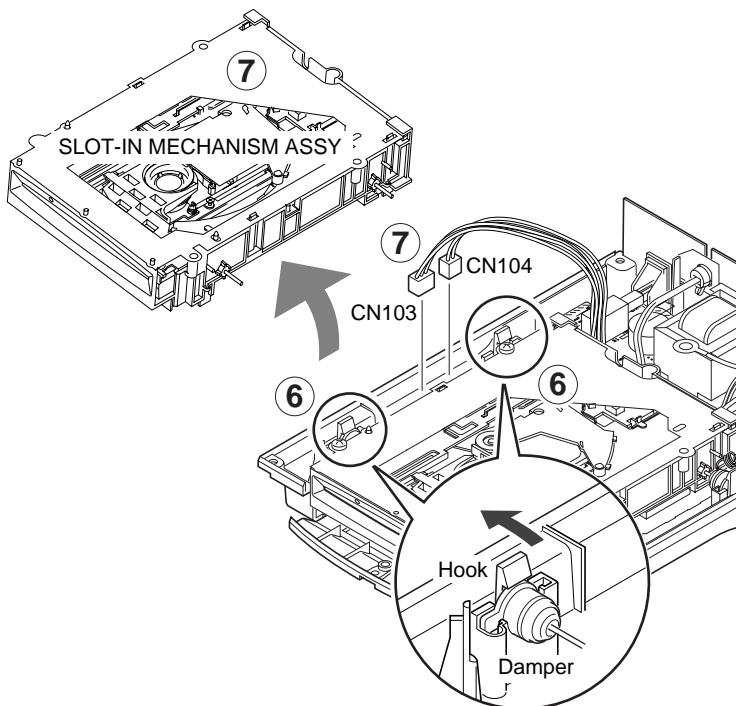

- ⑧ Remove the three screws (B), and then remove the mecha holder.

Note: An earth spring is located between the mecha holder and the mechanism assy (right side). Take care not to lose this spring.

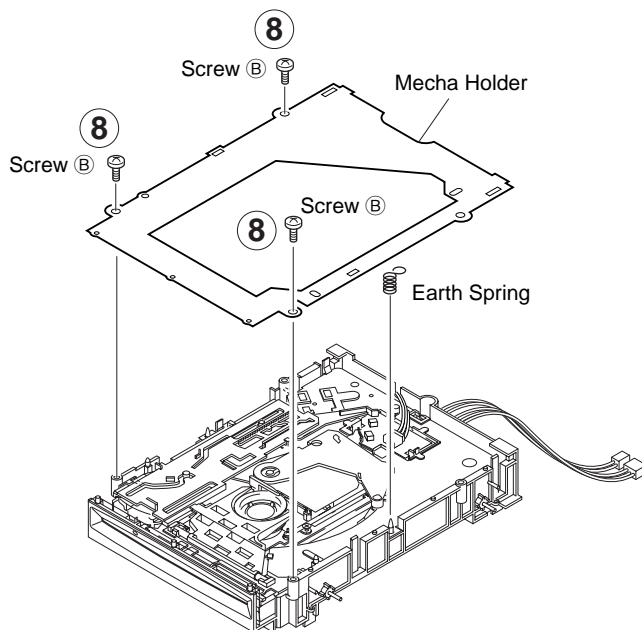

- ⑨ Disengage the hooks on the left and right side (2 each), and remove the loading base assy.
- ⑩ Remove the servo mechanism assy.

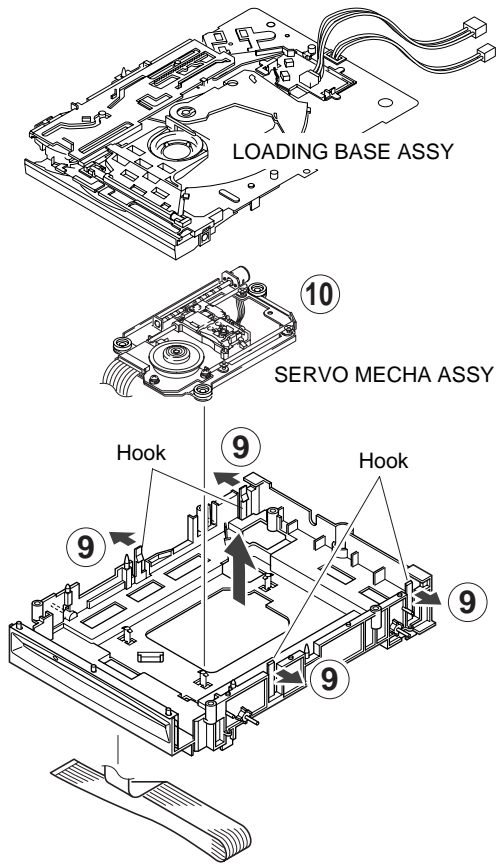

■ Removal of the Each P. C. Boards

● TRANS BOARD Assy

- ① With the slot-in Mechanism Assy removed, disconnect the connector (CN705).
- ② Remove the screw C and disconnect the cable stay.
- ③ Remove the seven screws D, raise front side of the TRANS BOARD assy, and remove it.

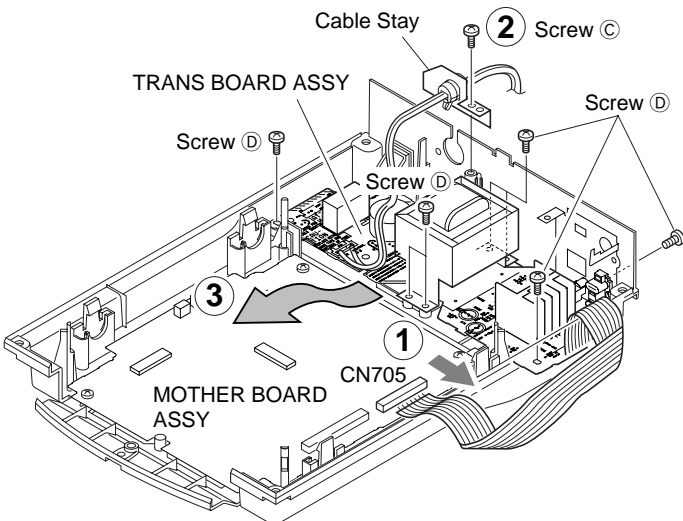

● DISPLAY BOARD Assy

- ① Remove the jog dial and the slide knob at the top of the body, and then remove the nut (M9) and jog washer.

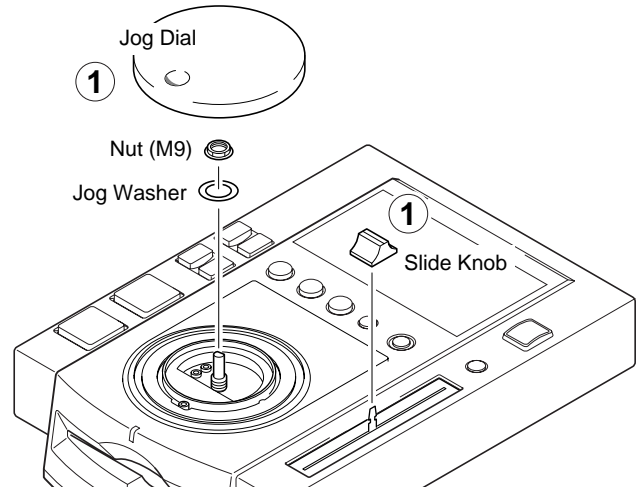

- ② Disconnect the earth lead unit.
- ③ Remove the 13 screws F.

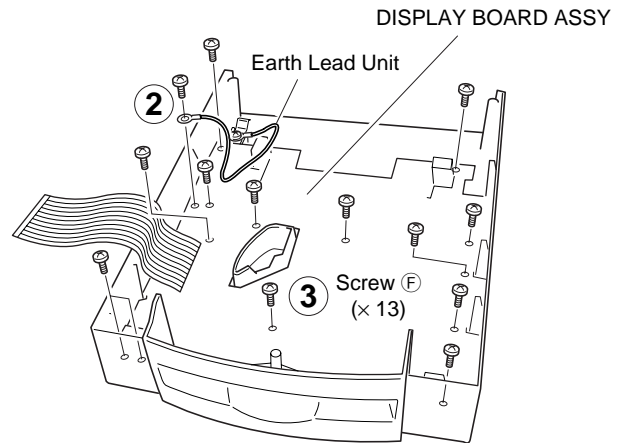

Caution for the time of assembly

Turn the jog dial and check for abnormalities like uneven turning etc.

Nut Tightening Torque: 8 kg · cm or less

■ Exchange Methods for Rotary Encoder (S614: DSX1051) and Slide Volume (VR601: DCV1009)

● Rotary Encoder (S614: DSX1051)

- ① Remove the jog dial, the nut (M9) and the jog washer at the top of the unit. (Refer to "Removal of the DISPLAY BOARD Assy".)
- ② Unsolder the rotary encoder and cut the 8 locations shown in the figure with nippers or similar.
- ③ Raise the P.C. board while paying attention to the jumper wires and remove the rotary encoder.

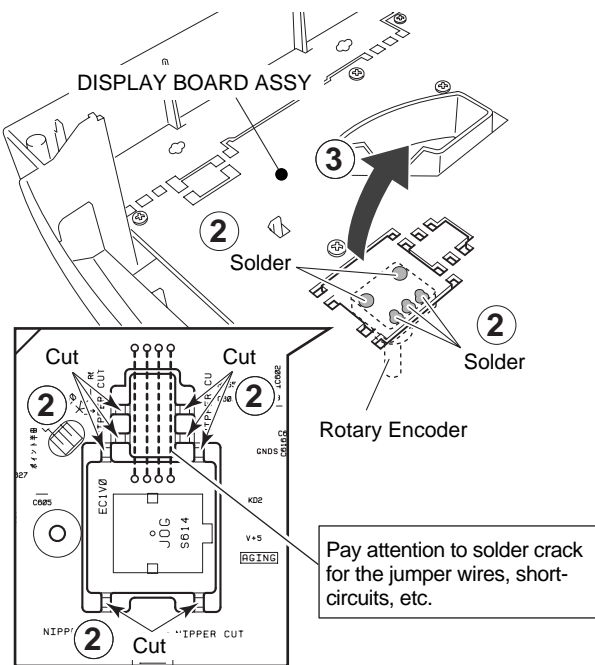

● Slide Volume (VR601: DCV1009)

- ① Remove the slide knob from the top of the unit. (Refer to "Removal of the DISPLAY BOARD Assy".)
- ② Remove the two screws (A).
- ③ Unsolder the slide volume and cut the 11 locations shown in the figure with nippers or similar.
- ④ Raise the circuit board while paying attention to the jumper wires and remove the slide volume.

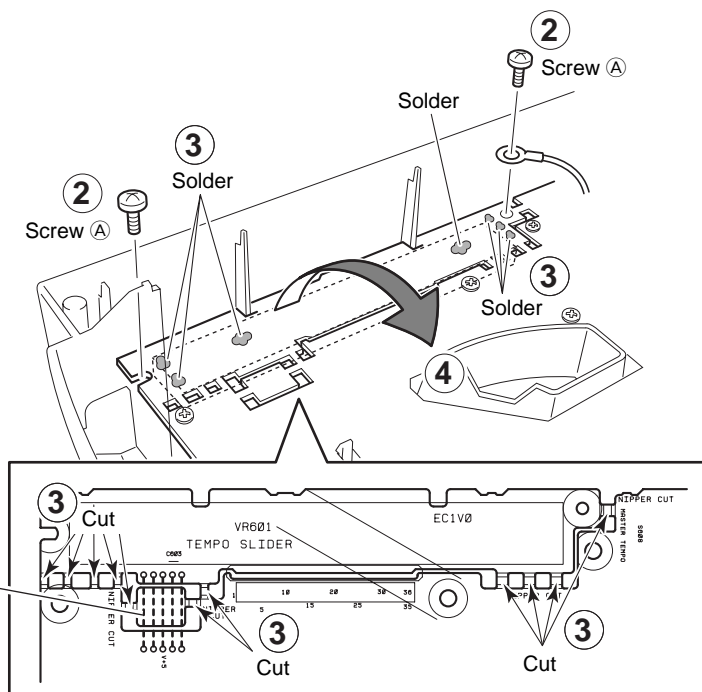

■ Measuring Points (TP) for Diagnosis

Remove the two screws (G) at the bottom plate. Then measuring at the each points becomes possible.

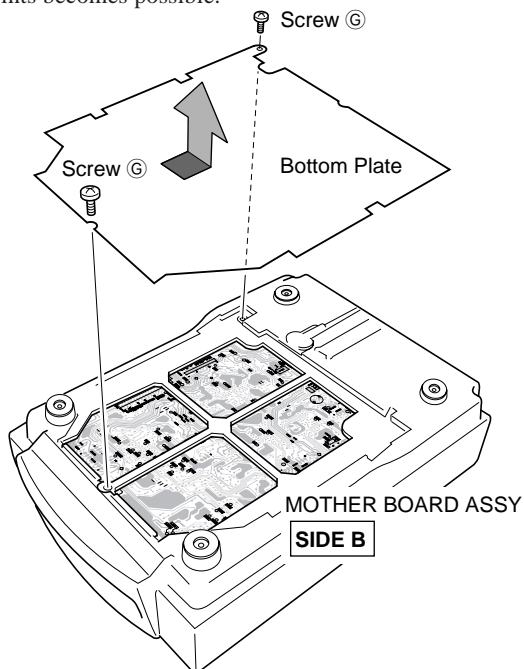

7.3 BLOCK DIAGRAM

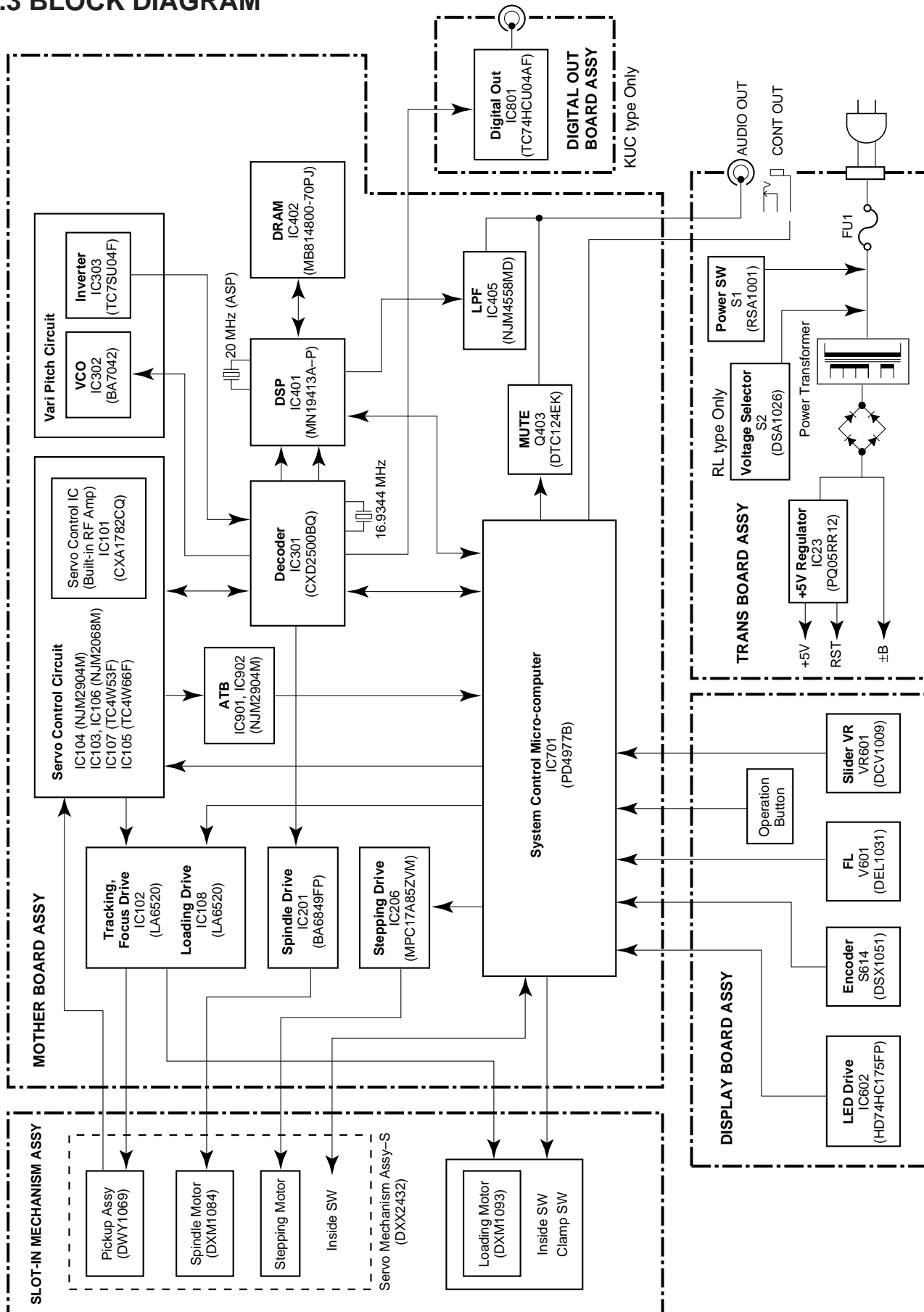

8. PANEL FACILITIES AND SPECIFICATIONS

■ PANEL FACILITIES

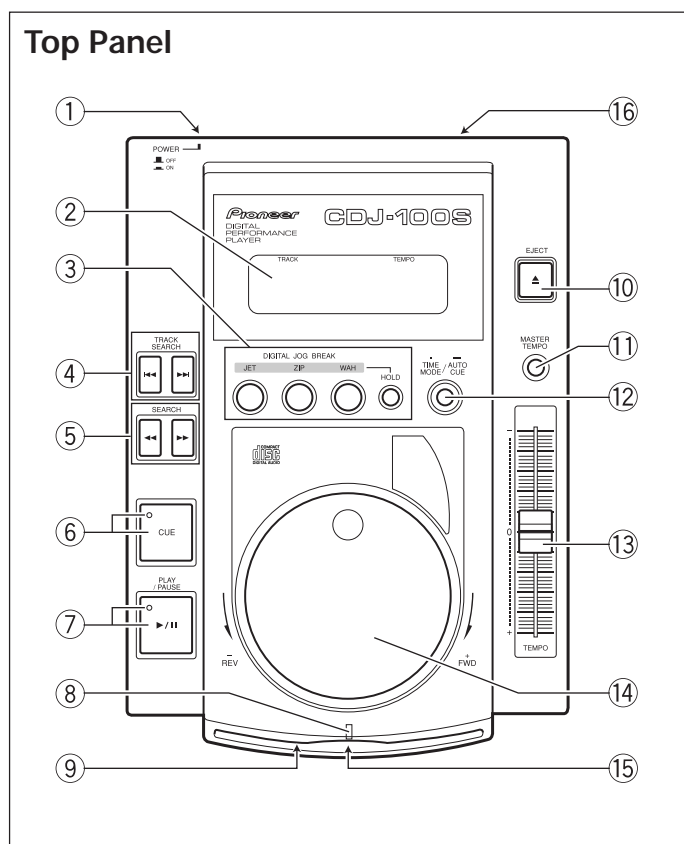

- ① **POWER switch**
(Located on rear panel)
Provides electrical power to the player.
- ② **Display window**
- ③ **DIGITAL JOG BREAK buttons**
(JET, ZIP, WAH, HOLD)
- ④ **TRACK SEARCH buttons** (◀◀, ▶▶)
- ⑤ **SEARCH buttons** (◀◀, ▶▶)
- ⑥ **CUE button/indicator**
- ⑦ **PLAY/PAUSE button/indicator** (▶/||)
- ⑧ **Loading indicator**
Flashes while disc is being loaded or removed through loading slot, and lights steadily when a disc is loaded in the player.
- ⑨ **Force ejection hole**
- ⑩ **EJECT button**
When this button is pressed, disc rotation stops and the disc is ejected from the player's loading slot.

- ⑪ **MASTER TEMPO button**
 - The master tempo function is turned ON/OFF.
 - If the button is held depressed for 2 seconds or more, the tempo adjust dial's variable range is changed ($\pm 10\%$ or $+10\%$ to -16%). When the variable range is changed, the newly selected numerical range is displayed for about 2 seconds (10.0 / 16.0).
 - The variable range is set by default to the ± 10 setting whenever power is first turned on.

⑫ **TIME MODE/AUTO CUE button**

Two functions are available.

[Time display]

Each time this button is pressed, the time display changes between the elapsed playback time of the track and the remaining playback time of the track (REMAIN).

- The REMAIN display appears when power is turned ON.

[Auto Cue function]

When a disc is initially loaded or when performing track search, this function automatically sets the cue point (the point immediately preceding actual sound output).

- The Auto Cue function defaults to OFF when power is first turned on.

⑬ **TEMPO control knob**

The playback tempo can be changed with this knob. The center clicked position is for normal playback tempo. If you slide the knob (down) towards you (+ side), the music tempo quickens. If the knob is away from you (- side), the music tempo slows.

⑭ **Jog dial (+ FWD/- REV)**

⑮ **Disc loading slot**

Insert discs with label side up.

- When playing 8 cm (3-inch) discs, insert the disc in a commercially available CD adapter before loading it in the CD player.

⑯ **DIGITAL OUT switch** (Located on rear panel)

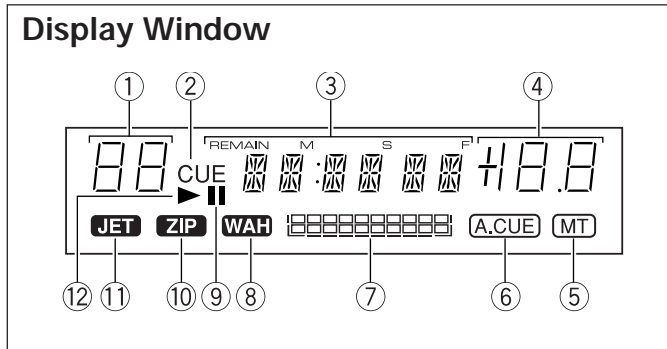

- ① **TRACK number display**
Displays the current number of the track playing.
- ② **CUE indicator**
Flashes when it is possible to input cue point, and lights steadily after the completion of input.
- ③ **Time display (REMAIN)**
The elapsed playback time of the track being played (when the REMAIN indicator is off) or the remaining playback time of the track being played (when the REMAIN indicator is on) is displayed in minutes (M) and seconds (S), or frames (F).
- ④ **Playback tempo display**
Tempo changes made with the TEMPO control knob are performed in 0.1% steps in the ±10% range. 0 to +10% in the +10% to -16% range is indicated in 0.1% steps and 0.2% steps from 0 to -16%.

- ⑤ **MT indicator**
Lights when the MASTER TEMPO function is used.
- ⑥ **A.CUE indicator**
Lights when the AUTO CUE function is used.
- ⑦ **Playback address display**
The elapsed playback time or remaining playback time of the track playing is roughly indicated with the full-scaled bar graph.
 - When no disc is in the disc compartment off
 - When displaying elapsed playback time lights up from the left side
 - When displaying remaining playback time turns off from the left side
 - When remaining playback time is less than 30 seconds blinks
- ⑧ **WAH indicator**
Lights or blinks when WAH function is active.
- ⑨ **Pause indicator (⏸)**
Blinks during pause mode.
- ⑩ **ZIP indicator**
Lights or blinks when ZIP function is active.
- ⑪ **JET indicator**
Lights or blinks when JET function is active.
- ⑫ **Play indicator (▶)**
Lights during playback.

■ SPECIFICATIONS

1. General

System	Compact disc digital audio system
Power requirements	AC 120 V, 60 Hz
Power consumption	12 W
Operating temperature	+5°C – +35°C (+41°F – +95°F)
Operating humidity	5% – 85%
(There should be no condensation of moisture.)	
Weight	2.2 kg (4 lbs 14 oz)
Dimensions	217.7 (W) × 310.7 (D) × 94.5 (H) mm
	8-9/16 (W) × 12-1/4 (D) × 3-3/4 (H) in.

2. Audio section

Frequency response	4 Hz – 20 kHz (EIAJ)
Signal-to-noise ratio	96 dB or more (EIAJ)
Output level	2.0 V
Channels	2-channel (stereo)

3. Accessories

● Operating instructions	1
● Audio cable	1
● Limited warranty	1

NOTE:

Specifications and design are subject to possible modification without notice.

Maintenance:

We recommend regular maintenance to ensure the safe and proper function of this unit. Extended service life can be expected if the unit maintained properly.