

# Pioneer

## Service Manual

ORDER NO.  
**RRV4015**

COMPACT DISC PLAYER

# CDJ-400-K

**THIS MANUAL IS APPLICABLE TO THE FOLLOWING MODEL(S) AND TYPE(S).**

Model	Type	Power Requirement	Remarks
CDJ-400-K	CUXJ	AC 120 V	
CDJ-400-K	SYXJ5	AC 220 V to 240 V	
CDJ-400-K	FLXJ	AC 110 V to 240 V	

**This service manual should be used together with the following manual(s):**

Model	Order No.	Remarks
CDJ-400/KUCXJ	RRV3679	

This product is based on CDJ-400.

Major features that are different from CDJ-400 are in the following.

Panel color: black

LED color:

JOG RING	AMBER RED -> BLUE
JOG SIDE	AMBER RED -> BLUE
LOOP IN, LOOP OUT	AMBER -> BLUE
REROOP, BEATROOP	AMBER -> BLUE
DISC IN	GREEN -> BLUE

**PIONEER CORPORATION** 4-1, Meguro 1-chome, Meguro-ku, Tokyo 153-8654, Japan  
**PIONEER ELECTRONICS (USA) INC.** P.O. Box 1760, Long Beach, CA 90801-1760, U.S.A.  
**PIONEER EUROPE NV** Haven 1087, Keetberglaan 1, 9120 Melsele, Belgium  
**PIONEER ELECTRONICS ASIACENTRE PTE. LTD.** 253 Alexandra Road, #04-01, Singapore 159936

©PIONEER CORPORATION 2009

T-ZZE-001 OCT. 2009 Printed in Japan

# 1. CONTRAST OF MISCELLANEOUS PARTS

NOTES: ● Parts marked by "NSP" are generally unavailable because they are not in our Master Spare Parts List.

● The  $\Delta$  mark found on some component parts indicates the importance of the safety factor of the part. Therefore, when replacing, be sure to use parts of identical designation.

● Screws adjacent to  $\nabla$  mark on product are used for disassembly.

● For the applying amount of lubricants or glue, follow the instructions in this manual. (In the case of no amount instructions, apply as you think it appropriate.)

● Nos. indicate the pages and Nos. in the service manual for the base model.

● When ordering resistors, first convert resistance values into code form as shown in the following examples.

Ex.1 When there are 2 effective digits (any digit apart from 0), such as 560 ohm and 47k ohm (tolerance is shown by J=5%, and K=10%).

560Ω	→	56 x 10 <sup>1</sup>	→	561	.....	RD1/4PU	5	6	1	J
47kΩ	→	47 x 10 <sup>3</sup>	→	473	.....	RD1/4PU	4	7	3	J
0.5Ω	→	R50	.....			RN2HR	5	0		K
1Ω	→	1R0	.....			RS1P	1	0		K

Ex.2 When there are 3 effective digits (such as in high precision metal film resistors).

5.62kΩ	→	562 x 10 <sup>1</sup>	→	5621	.....	RN1/4PC	5	6	2	1	F
--------	---	-----------------------	---	------	-------	---------	---	---	---	---	---

## 1.1 CONTRAST TABLE

(1) CDJ-400/KUCXJ and CDJ-400-K/CUXJ are constructed the same except for the following:

Mark	No.	Symbol and Description	CDJ-400/KUCXJ	CDJ-400-K/CUXJ	Remarks	
NSP	P45-2	<b>PCB ASSEMBLIES</b>				
		1..PNLA ASSY	DWM2323	DWM2395		
	2..PNLB ASSY	DWX2756	DWX3137			
	P41-14 P41-6 P41-15 P41-16	<b>PACING SECTION</b>				
		Packing Case	DHG2710	DHG2859		
		Jog Sheet 1	DAH2636	DAH2777		
Jog Sheet 2		DAH2638	DAH2778			
Jog Sheet 3	DAH2640	DAH2779				
NSP	P43-14	<b>EXTERIOR SECTION</b>				
		Chassis	DNK4984	DNK5596		
	P45-24 P45-35 P45-37 P45-38	<b>CONTROL PANEL SECTION</b>				
		Display Panel	DAH2616	DAH2776		
		Control Panel Assy	DXB1995	DXB2070		
		Top Panel (L)	DNK5031	DNK5607		
Top Panel (R)	DNK5073	DNK5608				

(2) CDJ-400/WYXJ5 and CDJ-400-K/SYXJ5 are constructed the same except for the following:

Mark	No.	Symbol and Description	CDJ-400/WYXJ5	CDJ-400-K/SYXJ5	Remarks	
NSP	P45-2	<b>PCB ASSEMBLIES</b>				
		1..PNLA ASSY	DWM2313	DWM2394		
	2..PNLB ASSY	DWX2756	DWX3137			
	P41-14 P41-6 P41-15 P41-16	<b>PACKING SECTION</b>				
		Packing Case	DHG2709	DHG2858		
		Jog Sheet 1	DAH2636	DAH2777		
Jog Sheet 2		DAH2638	DAH2778			
Jog Sheet 3	DAH2640	DAH2779				
NSP	P43-14	<b>EXTERIOR SECTION</b>				
		Chassis	DNK4983	DNK5595		
	P45-24 P45-35 P45-37 P45-38	<b>CONTROL PANEL SECTION</b>				
		Display Panel	DAH2616	DAH2776		
		Control Panel Assy	DXB1995	DXB2070		
		Top Panel (L)	DNK5031	DNK5607		
Top Panel (R)	DNK5073	DNK5608				

(3) CDJ-400/TLFXJ and CDJ-400-K/FOLOXJ are constructed the same except for the following:

Mark	No.	Symbol and Description	CDJ-400/TLFXJ	CDJ-400-K/FOLOXJ	Remarks
NSP	P45-2	<b>PCB ASSEMBLIES</b>			
		1..PNLA ASSY	DWM2313	DWM2394	
		2..PNLB ASSY	DWX2756	DWX3137	
		<b>PACKING SECTION</b>			
	P41-14	Packing Case	DHG2711	DHG2856	
	P41-6	Jog Sheet 1	DAH2636	DAH2777	
	P41-15	Jog Sheet 2	DAH2638	DAH2778	
	P41-16	Jog Sheet 3	DAH2640	DAH2779	
		<b>EXTERIOR SECTION</b>			
NSP	P43-14	Chassis	DNK4985	DNK5605	
		<b>CONTROL PANEL SECTION</b>			
	P45-24	Display Panel	DAH2616	DAH2776	
	P45-35	Control Panel Assy	DXB1995	DXB2070	
	P45-37	Top Panel (L)	DNK5031	DNK5607	
	P45-38	Top Panel (R)	DNK5073	DNK5608	

## 1.2 CONTRAST OF PCB ASSEMBLIES

### **F** PNLB ASSY

DWX2756 and DWX3137 are constructed the same except for the following:

Mark	Symbol and Description	DWX2756	DWX3137	Remarks
	D1119 LED	SLI-343U3R (HJKL)	SLR343BC4T (JK)	
	D1120 LED	SLI-343U3R (HJKL)	SLR343BC4T (JK)	
	D1121 LED	SLI-343U3R (HJKL)	SLR343BC4T (JK)	
	D1122 LED	SLI-343U3R (HJKL)	SLR343BC4T (JK)	
	D1123 LED	SLI-343U3R (HJKL)	SLR343BC4T (JK)	
	D1124 LED	SLI-343U3R (HJKL)	SLR343BC4T (JK)	
	D1125 LED	SLI-343U3R (HJKL)	SLR343BC4T (JK)	
	D1126 LED	SLI-343U3R (HJKL)	SLR343BC4T (JK)	
	D1131 LED	SLI-343U3R (HJKL)	SLR343BC4T (JK)	
	D1132 LED	SLI-343U3R (HJKL)	SLR343BC4T (JK)	
	D1133 LED	SLI-343U3R (HJKL)	SLR343BC4T (JK)	
	D1134 LED	SLI-343U3R (HJKL)	SLR343BC4T (JK)	
	D1135 LED	SLI-343U3R (HJKL)	SLR343BC4T (JK)	
	D1136 LED	SLI-343U3R (HJKL)	SLR343BC4T (JK)	
	D1137 LED	SLI-343U3R (HJKL)	SLR343BC4T (JK)	
	D1138 LED	SLI-343U3R (HJKL)	SLR343BC4T (JK)	
	D1139 LED	SLI-343U3R (HJKL)	SLR343BC4T (JK)	
	D1140 LED	SLI-343U3R (HJKL)	SLR343BC4T (JK)	
	D1141 LED	SLI-343U3R (HJKL)	SLR343BC4T (JK)	
	D1142 LED	SLI-343U3R (HJKL)	SLR343BC4T (JK)	
	D1143 LED	SLI-343U3R (HJKL)	SLR343BC4T (JK)	
	D1144 LED	SLI-343U3R (HJKL)	SLR343BC4T (JK)	
	D1145 LED	SLI-343U3R (HJKL)	SLR343BC4T (JK)	
	D1146 LED	SLI-343U3R (HJKL)	SLR343BC4T (JK)	
	D1148 LED	SLI-343U3R (HJKL)	SLR343BC4T (JK)	
	D1149 LED	SLI-343U3R (HJKL)	Not used	
	D1150 LED	SLI-343U3R (HJKL)	SLR343BC4T (JK)	
	D1158 LED	SLI-343U3R (HJKL)	Not used	

Mark	Symbol and Description	DWX2756	DWX3137	Remarks
A	D1160 LED	SLI-343U3R (HJKL)	Not used	
	D1161 LED	SLI-343U3R (HJKL)	SLR343BC4T (JK)	
	D1162 LED	SLI-343U3R (HJKL)	SLR343BC4T (JK)	
	D1163 LED	SLI-343U3R (HJKL)	Not used	
	D1101 LED	SLI-343Y8C (KLMN)	SLR343BC4T (JK)	Specified parts.
	D1110 LED	SLI-343Y8C (KLMN)	SLR343BC4T (J)	Use this part number.
	D1112 LED	SLI-343Y8C (KLMN)	SLR343BC4T (J)	Specified parts.
	D1113 LED	SLI-343Y8C (KLMN)	SLR343BC4T (JK)	Use this part number.
	D1108 LED	SLR343BC4T (JKLM)	SLR343BC4T (JK)	
	D1157 LED	SLI-343M8C (FGHJ)	SLR343BC4T (JK)	
B	R1145	RS1/10SR122J	RS1/10SR621J	
	R1153	RS1/10SR122J	RS1/10SR621J	
	R1160	RS1/10SR431J	RS1/10SR621J	
	R1167	RS1/8SQ271J	RS1/8SQ471J	
	R1168	RS1/8SQ221J	RS1/8SQ471J	
	R1172	RS1/8SQ221J	RS1/8SQ471J	
	R1173	RS1/8SQ271J	RS1/8SQ471J	
	R1192	RS1/10SR391J	RS1/10SR621J	
	R1193	RS1/10SR391J	RS1/10SR621J	
	R1197	RS1/10SR271J	RS1/10SR181J	
C	R1198	RS1/10SR271J	RS1/10SR181J	
	R1199	RS1/10SR271J	RS1/10SR181J	
	R1200	RS1/10SR271J	RS1/10SR181J	
	R1206	RS1/8SQ221J	RS1/8SQ471J	
	R1207	RS1/8SQ271J	RS1/8SQ471J	
	R1211	RS1/8SQ221J	RS1/8SQ471J	
	R1212	RS1/8SQ271J	RS1/8SQ471J	
	R1216	RS1/8SQ271J	RS1/8SQ471J	
	R1217	RS1/8SQ221J	RS1/8SQ471J	
	R1221	RS1/8SQ221J	RS1/8SQ471J	
D	R1222	RS1/8SQ271J	RS1/8SQ471J	
	R1226	RS1/8SQ221J	RS1/8SQ471J	
	R1227	RS1/8SQ271J	RS1/8SQ471J	
	R1231	RS1/8SQ221J	RS1/8SQ471J	
	R1232	RS1/8SQ271J	RS1/8SQ471J	
	R1249	RS1/10SR301J	RS1/10SR511J	
	R1266	RS1/10SR103J	RS1/10SR153J	
	R1285	Not used	RS1/10SR6R8J	
	R1286	Not used	RS1/10SR6R8J	
	R1287	Not used	RS1/10SR6R8J	
R1288	Not used	RS1/10SR6R8J		
E				
F				



5



6



7



8



A



B



C



D



E



F



5



6

CDJ-400-K



7



8

5



# 2. BLOCK DIAGRAM

## 2.1 OVERALL WIRING DIAGRAM

A

B

C

D

E

F

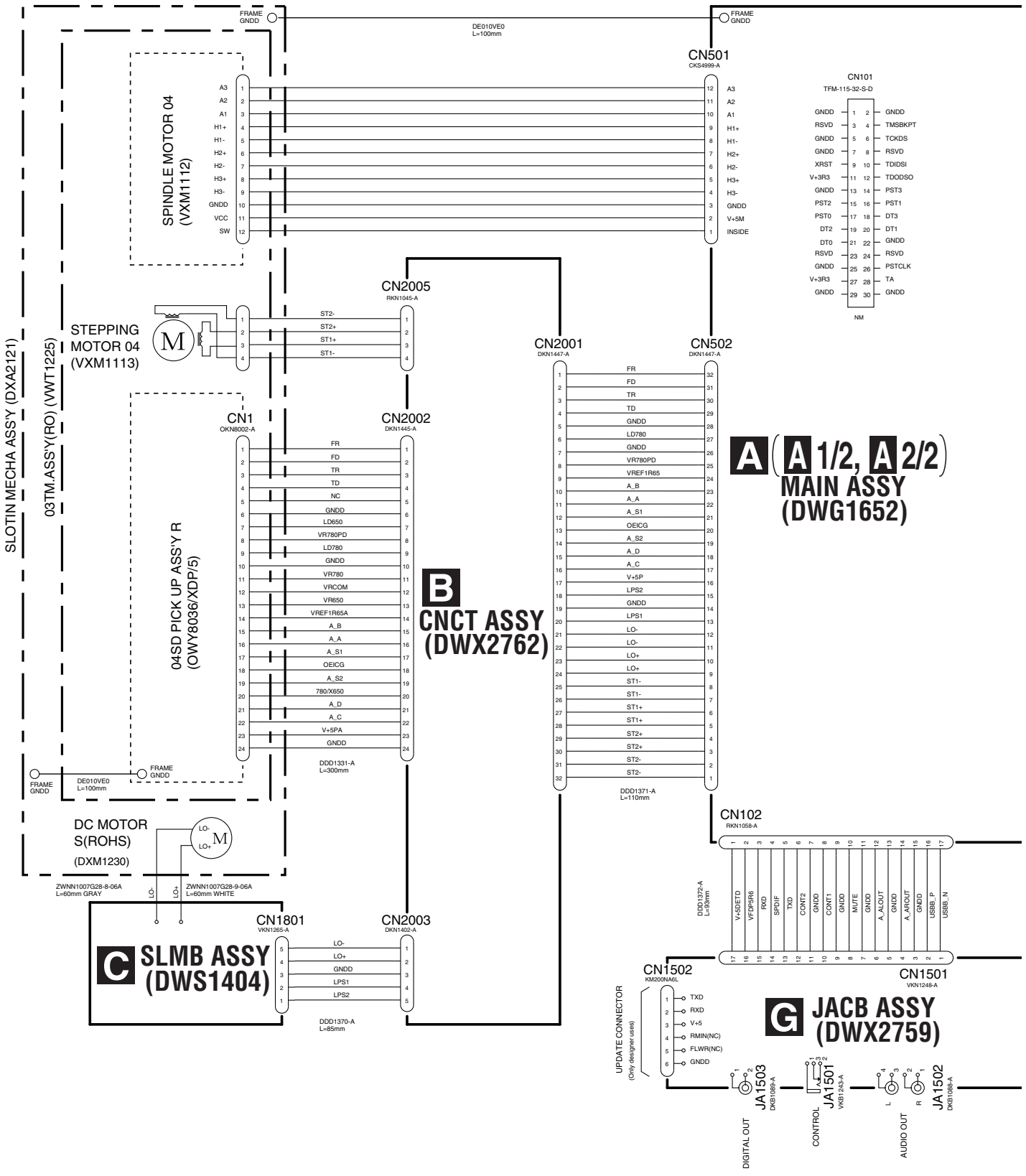

**CN101**  
TFM-115-32-S-D

GNDD	1	2	GNDD
RSVD	3	4	TMSKPT
GNDD	5	6	TCKDS
GNDD	7	8	RSVD
XRST	9	10	TDISI
V+3R3	11	12	TDODSO
GNDD	13	14	PST3
PST2	15	16	PST1
PST0	17	18	DT3
DT2	19	20	DT1
DT0	21	22	GNDD
RSVD	23	24	RSVD
GNDD	25	26	PSTCLK
V+3R3	27	28	TA
GNDD	29	30	GNDD

NM

**A (A 1/2, A 2/2)**  
**MAIN ASSY**  
**(DWG1652)**

**B**  
**CNCT ASSY**  
**(DWX2762)**

**C**  
**SLMB ASSY**  
**(DWS1404)**

**G**  
**JACB ASSY**  
**(DWX2759)**

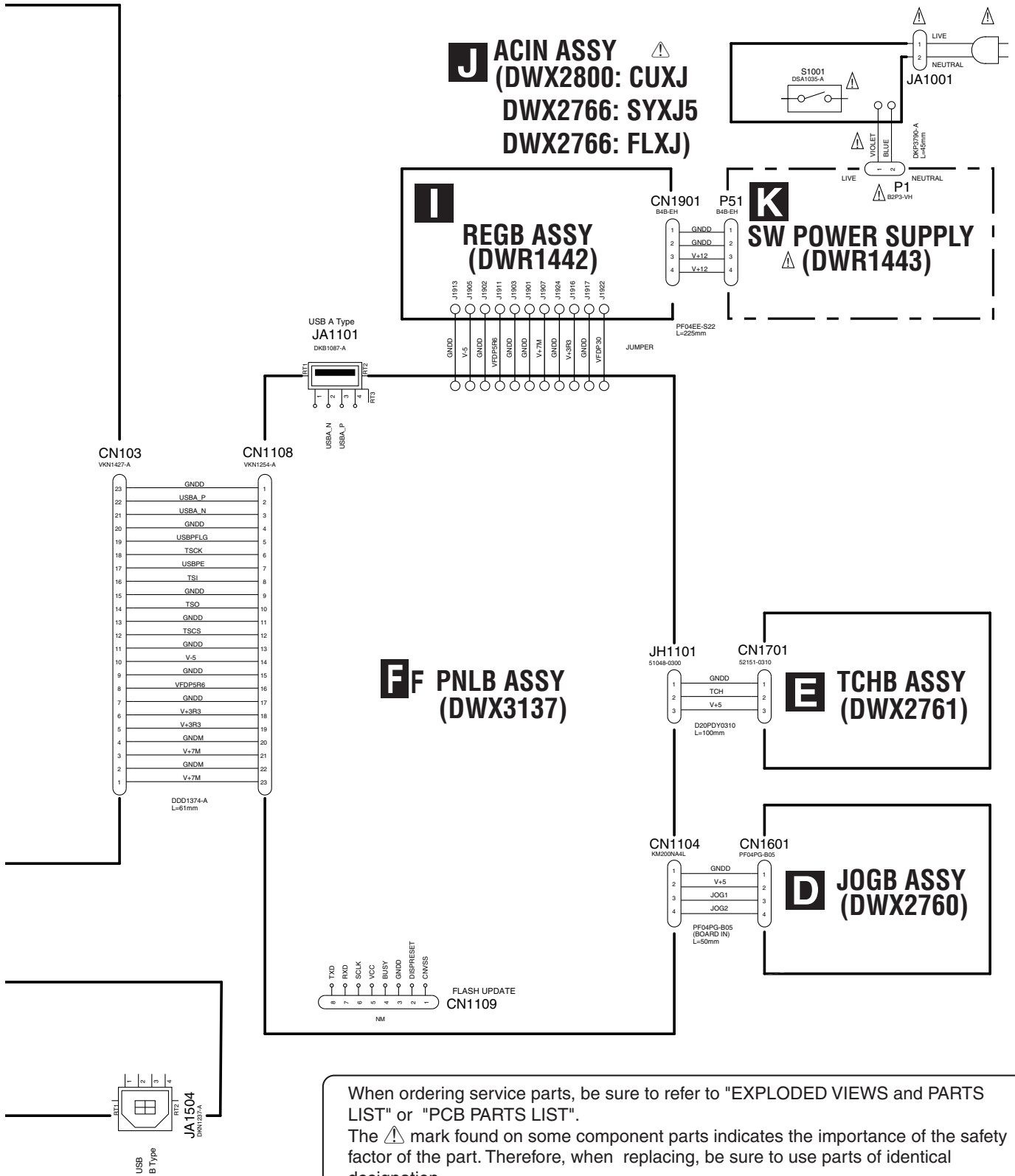

When ordering service parts, be sure to refer to "EXPLODED VIEWS and PARTS LIST" or "PCB PARTS LIST".  
 The ⚠ mark found on some component parts indicates the importance of the safety factor of the part. Therefore, when replacing, be sure to use parts of identical designation.  
 : The power supply is shown with the marked box.

# 3. SCHEMATIC DIAGRAM

## 3.1 PNLB ASSY

CAUTION  
FOR CONTINUED PROTECTION AGAINST RISK OF FIRE,  
REPLACE ONLY WITH SAME TYPE NO.  
DEK1096-A 466.750  
MFD. BY LITTELFUSE INC. FOR P1101

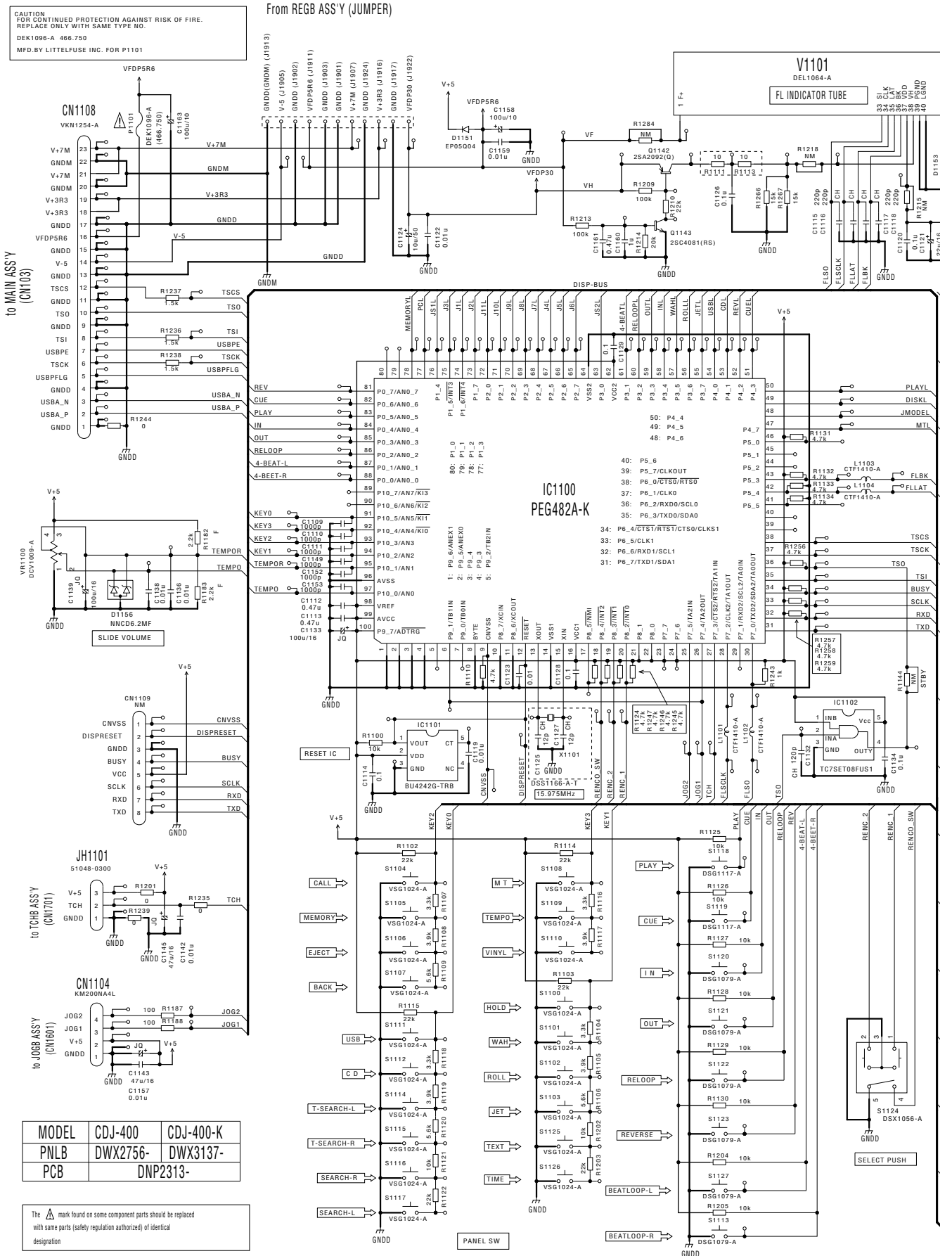

MODEL	CDJ-400	CDJ-400-K
PNLB	DWX2756-	DWX3137-
PCB	DNP2313-	

The mark found on some component parts should be replaced with same parts (safety regulation authorized) of identical designation

A  
B  
C  
D  
E  
F



CDJ-400-K



# FF PNLB ASSY (DWX3137)

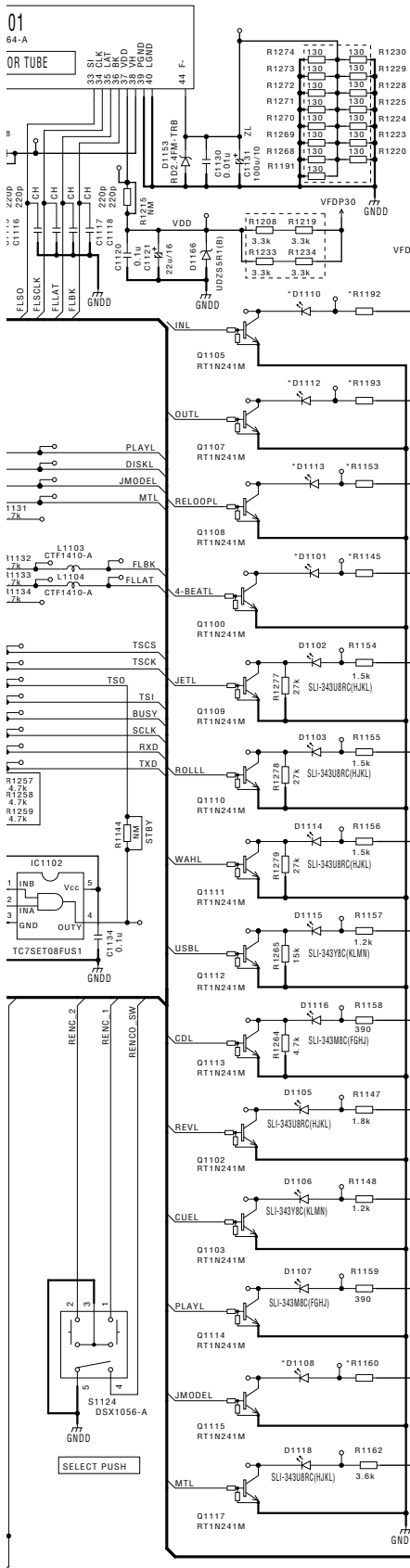

IN	OUT	CDJ-400 (AMBER) CDJ-400-K (BLUE)	RELOOP	BEAT LOOP	CDJ-400 (AMBER) CDJ-400-K (BLUE)
D1110, D1112	SLI-343Y8C(KLMN)	SLR343BC4T(J)	D1101, D1113	CDJ-400	CDJ-400-K
R1192, R1193	390(J%)	620	R1145, R1153	1.2k	620

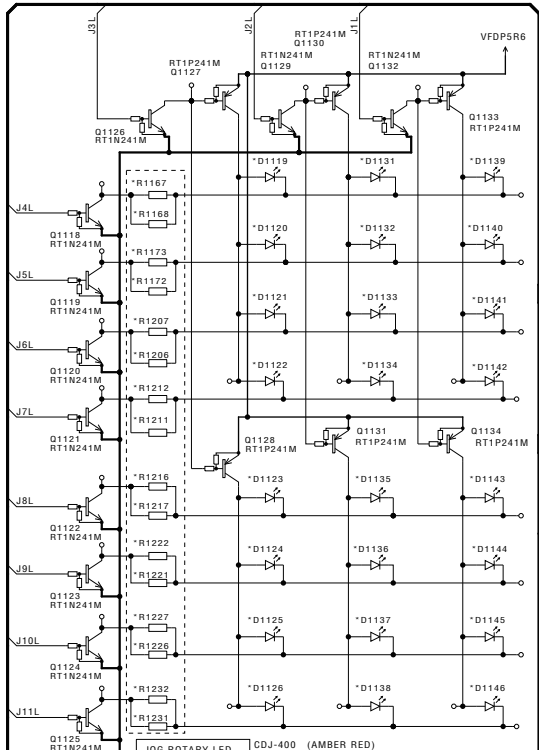

JOG SIDE LED	CDJ-400 (AMBER RED) CDJ-400-K (BLUE)
D1148, D1150 D1161, D1162	CDJ-400 SLI-343U3R(HJKL)
D1149, D1158 D1160, D1163	CDJ-400-K SLR343BC4T(JK)
R1197 ~ R1200	270
R1285 ~ R1288	No Mount

JOG ROTARY LED	CDJ-400 (AMBER RED) CDJ-400-K (BLUE)
D1119 ~ D1126	CDJ-400 SLI-343U3R(HJKL)
D1131 ~ D1146	CDJ-400-K SLR343BC4T(JK)
R1167, R1173, R1207, R1212 R1216, R1222, R1227, R1232	200
R1168, R1172, R1206, R1211 R1217, R1221, R1226, R1231	200

DISK IN	CDJ-400 (GREEN) CDJ-400-K (BLUE)
D1157	CDJ-400 SLI-343M8C(KLMN)
R1249	300
	CDJ-400-K SLR343BC4T(JK)
	510

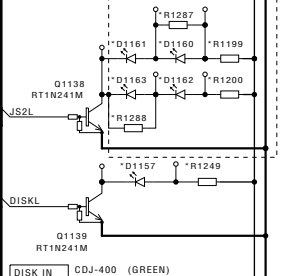

PC (AMBER)	CDJ-400 (GREEN) CDJ-400-K (BLUE)
D1164	CDJ-400 SLI-343Y8C(KLMN)
R1282	1.2k

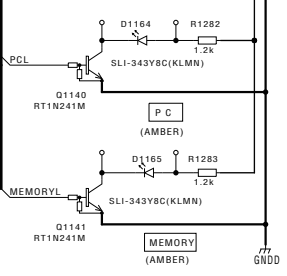

- NOTES**
- NM means STANDBY
  - RS1/16S\*\*\*J
  - RS1/16S\*\*\*F
  - RS1/10S\*\*\*J
  - CKSRVB
  - CCSRCH
  - CEHAR
  - CEJD
  - CEHAZL

JA1101  
DKB1087-A  
USB CONNECTOR  
A Type

VINYL	CDJ-400 (BLUE, JKLM) CDJ-400-K (BLUE, JK)
D1188	CDJ-400 SLR343BC4T(KLM)
R1190	CDJ-400-K SLR343BC4T(JK)
	400
	620

## CDJ-400-K

