

Service Manual

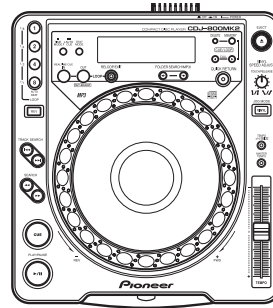

CDJ-800MK2

ORDER NO.
RRV3364

COMPACT DISC PLAYER

CDJ-800MK2

THIS MANUAL IS APPLICABLE TO THE FOLLOWING MODEL(S) AND TYPE(S).

Model	Type	Power Requirement	Remarks
CDJ-800MK2	KUCXJ	AC 120 V	
CDJ-800MK2	WYXJ5	AC 220 – 240 V	
CDJ-800MK2	RLFXJ	AC 110-120 V / 220-240 V	



For details, refer to "Important symbols for good services" .

SAFETY INFORMATION



This service manual is intended for qualified service technicians ; it is not meant for the casual do-it-yourselfer. Qualified technicians have the necessary test equipment and tools, and have been trained to properly and safely repair complex products such as those covered by this manual. Improperly performed repairs can adversely affect the safety and reliability of the product and may void the warranty. If you are not qualified to perform the repair of this product properly and safely, you should not risk trying to do so and refer the repair to a qualified service technician.



WARNING

This product contains lead in solder and certain electrical parts contain chemicals which are known to the state of California to cause cancer, birth defects or other reproductive harm.

Health & Safety Code Section 25249.6 – Proposition 65



NOTICE

(FOR CANADIAN MODEL ONLY)

Fuse symbols  (fast operating fuse) and/or  (slow operating fuse) on PCB indicate that replacement parts must be of identical designation.

REMARQUE

(POUR MODÈLE CANADIEN SEULEMENT)

Les symboles de fusible  (fusible de type rapide) et/ou  (fusible de type lent) sur CCI indiquent que les pièces de remplacement doivent avoir la même désignation.

(FOR USA MODEL ONLY)

1. SAFETY PRECAUTIONS

The following check should be performed for the continued protection of the customer and service technician.

LEAKAGE CURRENT CHECK

Measure leakage current to a known earth ground (waterpipe, conduit, etc.) by connecting a leakage current tester such as Simpson Model 229-2 or equivalent between the earth ground and all exposed metal parts of the appliance (input/output terminals, screwheads, metal overlays, control shaft, etc.). Plug the AC line cord of the appliance directly into a 120V AC 60Hz outlet and turn the AC power switch on. Any current measured must not exceed 0.5mA.

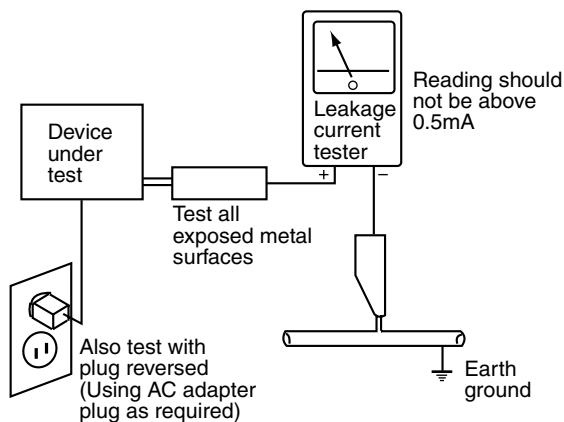

AC Leakage Test

ANY MEASUREMENTS NOT WITHIN THE LIMITS OUTLINED ABOVE ARE INDICATIVE OF A POTENTIAL SHOCK HAZARD AND MUST BE CORRECTED BEFORE RETURNING THE APPLIANCE TO THE CUSTOMER.

2. PRODUCT SAFETY NOTICE

Many electrical and mechanical parts in the appliance have special safety related characteristics. These are often not evident from visual inspection nor the protection afforded by them necessarily can be obtained by using replacement components rated for voltage, wattage, etc. Replacement parts which have these special safety characteristics are identified in this Service Manual.

Electrical components having such features are identified by marking with a Δ on the schematics and on the parts list in this Service Manual.

The use of a substitute replacement component which does not have the same safety characteristics as the PIONEER recommended replacement one, shown in the parts list in this Service Manual, may create shock, fire, or other hazards.

Product Safety is continuously under review and new instructions are issued from time to time. For the latest information, always consult the current PIONEER Service Manual. A subscription to, or additional copies of, PIONEER Service Manual may be obtained at a nominal charge from PIONEER.

IMPORTANT

THIS PIONEER APPARATUS CONTAINS LASER OF CLASS 1. SERVICING OPERATION OF THE APPARATUS SHOULD BE DONE BY A SPECIALLY INSTRUCTED PERSON.

LASER DIODE CHARACTERISTICS

MAXIMUM OUTPUT POWER: 5 mW
WAVELENGTH: 780 – 785 nm

WARNING !

The AEL(accessible emission level) of the laser power output is less than **CLASS 1** but the laser component is capable of emitting radiation exceeding the limit for **CLASS 1**.

A specially instructed person should servicing operation of the apparatus.

LABEL CHECK**CDJ-800MK2 WYXJ5 and KUCXJ : Types Only**

CAUTION	CLASS 3B INVISIBLE LASER RADIATION WHEN OPEN. AVOID EXPOSURE TO BEAM.	VORSICHT	BEI GEÖFFNETER ABDECKUNG IST UNSICHTBARE LASERSTRAHLUNG DER KLASSE 3B IM GERÄTEINNEREN VORHANDEN. NICHT DEM LASERSTRAHL AUSSETZEN!
ATTENTION	RADIATIONS LASER INVISIBLES DE CLASSE 3B QUAND OUVERT. ÉVITEZ TOUT EXPOSITION AU FAISCEAU.	PRECAUCIÓN	CUANDO SE ABRE HAY RADIACIÓN LASER DE CLASE 3B INVISIBLE. EVITE LA EXPOSICIÓN A LOS RAYOS LASER.
ADVARSEL	KLASSE 3B USYNLIG LASERSTRÅLING VED ÅBNING. UNDGÅ UDSÆTTELSE FOR STRÅLING.	VARO!	AVKATTAESSA OLET ALTIHINA NÄRYMÄTTÖMÄLLÄ LUOKAN 3B LASERSATEILYLLE. ÄLÄ KATSO SATEESEEN.
VARNING	KLASS 3B ÖSYNLIG LASERSTRÅLNING NÄR DENNA DEL ÄR ÖPPNAD. UNDVIK ATT UTSÄTTA DIG FÖR STRÅLEN.		DRW2308-A

(DRW2308)

for RLFXJ

CAUTION : CLASS 3B INVISIBLE LASER RADIATION WHEN OPEN, AVOID EXPOSURE TO THE BEAM.

注意：打開時會有 CLASS 3B 不可見雷射輻射，請勿受雷射束輻射。

DRW2246

(DRW2248)

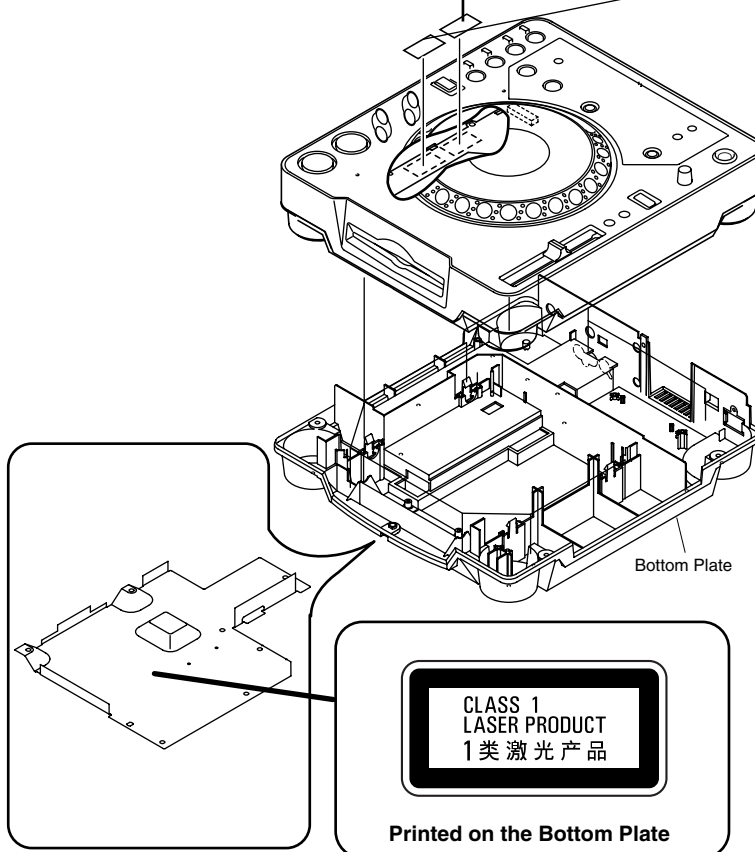
**Additional Laser Caution****1. Laser Interlock Mechanism**

The position of the switch (S1901) for detecting loading completion is detected by the system microprocessor, and the design prevents laser diode oscillation when the switch is not in LPS1 terminal side (when the mechanism is not clamped and LPS1 signal is high level.)

Thus, the interlock will no longer function if the switch is deliberately set to LPS1 terminal side. (if LPS1 signal is low level).

In the test mode* the interlock mechanism will not function. Laser diode oscillation will continue, if pin 41 of TC94A15FG (IC101) on the MAIN Assy is connected to GND, or else the terminals of Q101 are shorted to each other (fault condition).

2. When the cover is opened, close viewing of the objective lens with the naked eye will cause exposure to a Class 1 laser beam.

* : Refer to page 86.

[Important Check Points for Good Servicing]

In this manual, procedures that must be performed during repairs are marked with the below symbol. Please be sure to confirm and follow these procedures.

A

1. Product safety



Please conform to product regulations (such as safety and radiation regulations), and maintain a safe servicing environment by following the safety instructions described in this manual.

- ① Use specified parts for repair.

Use genuine parts. Be sure to use important parts for safety.

- ② Do not perform modifications without proper instructions.

Please follow the specified safety methods when modification (addition/change of parts) is required due to interferences such as radio/TV interference and foreign noise.

- ③ Make sure the soldering of repaired locations is properly performed.

When you solder while repairing, please be sure that there are no cold solder and other debris. Soldering should be finished with the proper quantity. (Refer to the example)

- ④ Make sure the screws are tightly fastened.

Please be sure that all screws are fastened, and that there are no loose screws.

- ⑤ Make sure each connectors are correctly inserted.

Please be sure that all connectors are inserted, and that there are no imperfect insertion.

- ⑥ Make sure the wiring cables are set to their original state.

Please replace the wiring and cables to the original state after repairs. In addition, be sure that there are no pinched wires, etc.

- ⑦ Make sure screws and soldering scraps do not remain inside the product.

Please check that neither solder debris nor screws remain inside the product.

- ⑧ There should be no semi-broken wires, scratches, melting, etc. on the coating of the power cord.

Damaged power cords may lead to fire accidents, so please be sure that there are no damages. If you find a damaged power cord, please exchange it with a suitable one.

- ⑨ There should be no spark traces or similar marks on the power plug.

When spark traces or similar marks are found on the power supply plug, please check the connection and advise on secure connections and suitable usage. Please exchange the power cord if necessary.

- ⑩ Safe environment should be secured during servicing.

When you perform repairs, please pay attention to static electricity, furniture, household articles, etc. in order to prevent injuries. Please pay attention to your surroundings and repair safely.

D

2. Adjustments



To keep the original performance of the products, optimum adjustments and confirmation of characteristics within specification. Adjustments should be performed in accordance with the procedures/instructions described in this manual.

3. Lubricants, Glues, and Replacement parts



Use grease and adhesives that are equal to the specified substance. Make sure the proper amount is applied.

E

4. Cleaning



For parts that require cleaning, such as optical pickups, tape deck heads, lenses and mirrors used in projection monitors, proper cleaning should be performed to restore their performances.

5. Shipping mode and Shipping screws



To protect products from damages or failures during transit, the shipping mode should be set or the shipping screws should be installed before shipment. Please be sure to follow this method especially if it is specified in this manual.

F

CONTENTS

SAFETY INFORMATION.....	2
1. SPECIFICATIONS	6
2. EXPLODED VIEWS AND PARTS LIST	8
2.1 PACKING	8
2.2 EXTERIOR SECTION	10
2.3 CONTROL PANEL SECTION.....	12
2.4 SLOT-IN MECHANISM SECTION	14
3. BLOCK DIAGRAM AND SCHEMATIC DIAGRAM	16
3.1 BLOCK DIAGRAM.....	16
3.2 BLOCK DIAGRAM (2)	18
3.3 BLOCK DIAGRAM (Power).....	20
3.4 OVERALL WIRING DIAGRAM	22
3.5 MAIN (1/3) and RLYB ASSYS	24
3.6 MAIN ASSY(2/3).....	26
3.7 MAIN ASSY(3/3).....	30
3.8 AC IN, TRNS, SECB and REGB ASSYS.....	32
3.9 DFLB, JACK and KSWB ASSYS	34
3.10 JFLB, SLDB, SLMB and JOGB ASSYS	36
3.11 WAVEFORMS.....	38
3.12 VOLTAGES.....	45
4. PCB CONNECTION DIAGRAM	49
4.1 MAIN ASSY	50
4.2 RLYB ASSY	54
4.3 SECB ASSY	56
4.4 TRNS ASSY.....	60
4.5 AC IN ASSYS	62
4.6 DFLB ASSY.....	64
4.7 REGB and JACK ASSYS.....	68
4.8 KSWB ASSY.....	70
4.9 JFLB ASSY.....	72
4.10 SLDB ASSY.....	76
4.11 SLMB and JOGB ASSYS	78
5. PCB PARTS LIST	80
6. ADJUSTMENT	85
7. GENERAL INFORMATION	86
7.1 DIAGNOSIS.....	86
7.1.1 SERVICE MODE.....	86
7.1.2 RESET and CLOCK MAP	92
7.1.3 TROUBLE SHOOTING	94
7.1.4 POWER ON SEQUENCE	105
7.1.5 DISASSEMBLY	106
7.2 PARTS	114
7.2.1 IC.....	114
8. PANEL FACILITIES	140

1. SPECIFICATIONS

Specifications

• KUCXJ type

1. General

System..... Compact disc digital audio system
 Power requirements..... AC 120 V, 60 Hz
 Power consumption..... 20 W
 Operating temperature..... +5°C to +35°C (+41°F to +95°F)
 Operating humidity..... 5 % to 85 %
 (There should be no condensation of moisture.)
 Weight..... 4.0 kg (8.8 lb)
 Dimensions..... 305 (W) × 344.1 (D) × 106.5 (H)mm
 12 (W) × 13 –9/16 (D) × 4 – 1/4 (H) in

2. Audio section

Frequency response..... 4 Hz to 20 kHz
 Signal-to-noise ratio..... 115 dB or more (JEITA)
 Distortion..... 0.006 % (JEITA)

3. Accessories

- Operating instructions..... 1
- Power cord..... 1
- Audio cable..... 1
- Control cable..... 1
- Forced eject pin (housed in a groove in the bottom panel)... 1
- Limited warranty..... 1

NOTE:

Specifications and design are subject to possible modification with-out notice.

• WYXJ5 type

1. General

System..... Compact disc digital audio system
 Power requirements AC 220-240 V, 50/60 Hz
 Power consumption 22 W
 Operating temperature +5°C to +35°C
 Operating humidity 5 % to 85 %
 (There should be no condensation of moisture.)
 Weight 4.0 kg
 Dimensions 305 (W) x 344.1 (D) x 106.5 (H) mm

2. Audio section

Frequency response..... 4 Hz to 20 kHz
 Signal-to-noise ratio 115 dB or more (JEITA)
 Distortion 0.006 % (JEITA)

3. Accessories

- Operating instructions 1
- Power cord 1
- Audio cable 1
- Control cable 1
- Forced eject pin (housed in a groove in the bottom panel)... 1

NOTE:

Specifications and design are subject to possible modification with-out notice.

• RLFXJ type

1. General

System..... Compact disc digital audio system
 Power requirements AC 110-120 V/220-240 V, 50/60 Hz
 Power consumption 22 W
 For Taiwan: 21 W
 Operating temperature +5°C to +35°C
 Operating humidity 5 % to 85 %
 (There should be no condensation of moisture.)
 Weight 4.0 kg
 Dimensions 305 (W) x 344.1 (D) x 106.5 (H) mm

2. Audio section

Frequency response..... 4 Hz to 20 kHz
 Signal-to-noise ratio 115 dB or more (JEITA)
 Distortion 0.006 % (JEITA)

3. Accessories

- Operating instructions 1
- Power cord 1
- Audio cable 1
- Control cable 1
- Forced eject pin (housed in a groove in the bottom panel)... 1

NOTE:

Specifications and design are subject to possible modification with-out notice.

Voltage selector (RLFXJ type only)

- You can find the voltage selector switch on the bottom plate of the unit.
 The factory setting for the voltage selector is 220 – 240 V.
 Please set it to the correct voltage for your country or region.
- For Taiwan, please set to 110 – 120 V before using.
 Before changing the voltage, disconnect the AC power cord.
 Use a medium size screwdriver to change the voltage selector switch.

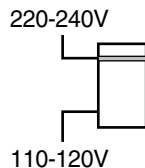

Accessories

Audio Cable
(VDE1064) L=1.5m



Power Cord
(ADG7021 : KUCXJ)
(ADG7097 : RLFXJ)



Forced Eject Pin
(housed in a groove in
the bottom panel)
(DEX1008)

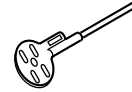

Control Cord
(XDE3063) L=1 m



(ADG1154 : WYXJ, RLFXJ)

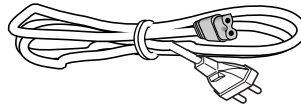

2. EXPLODED VIEWS AND PARTS LIST

- NOTES:
- Parts marked by "NSP" are generally unavailable because they are not in our Master Spare Parts List.
 - The \triangle mark found on some component parts indicates the importance of the safety factor of the part. Therefore, when replacing, be sure to use parts of identical designation.
 - Screws adjacent to \blacktriangledown mark on product are used for disassembly.
 - For the applying amount of lubricants or glue, follow the instructions in this manual. (In the case of no amount instructions, apply as you think it appropriate.)

2.1 PACKING

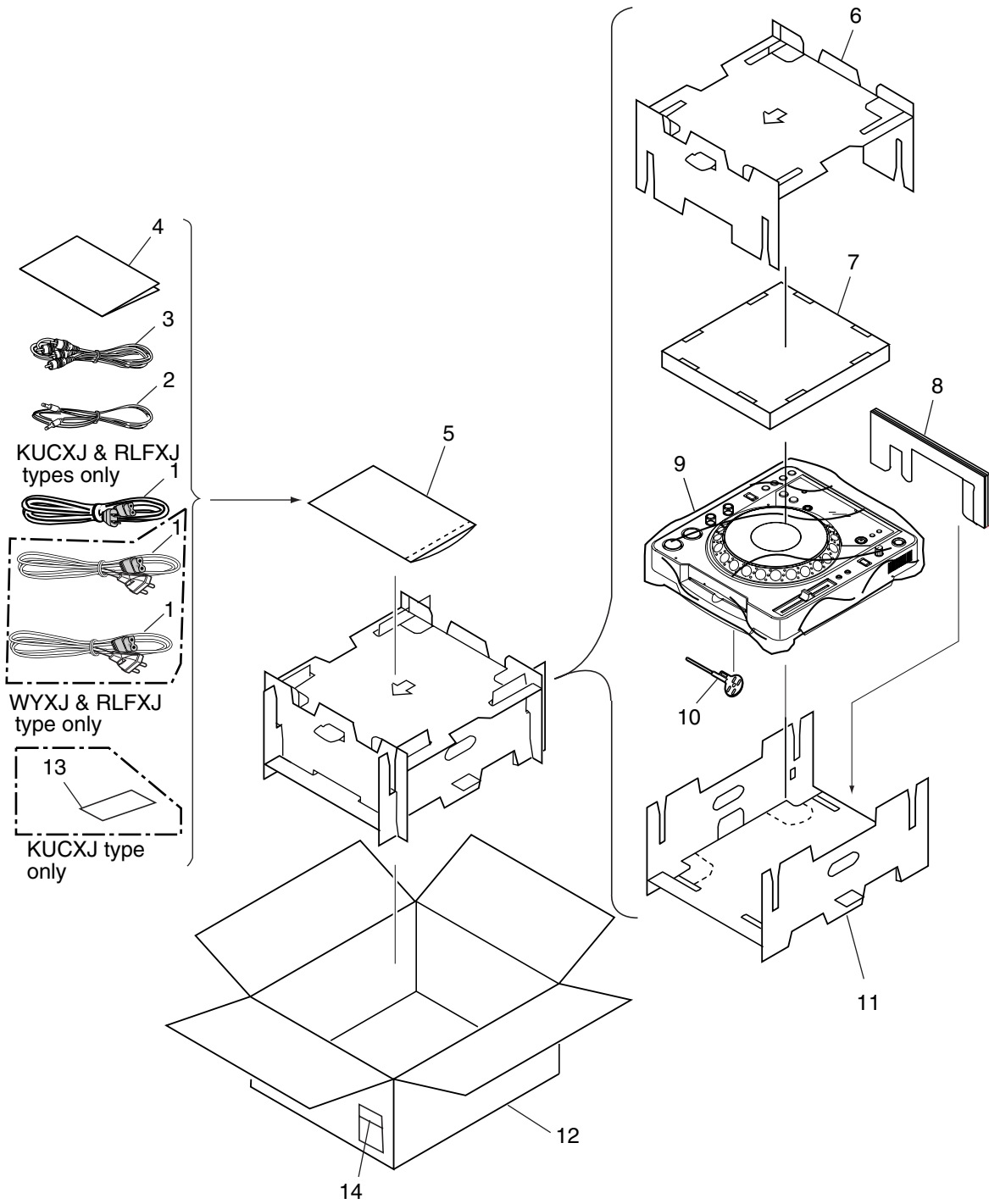

PACKING parts List

<u>Mark No.</u>	<u>Description</u>	<u>Part No.</u>	<u>Mark No.</u>	<u>Description</u>	<u>Part No.</u>
⚠ 1	AC Power Cord	See Contrast table(2)	9	Sheet	RHX1006
2	Control Cord	XDE3063	10	Push Rod	DEX1008
3	Audio Cord	VDE1064			
4	Operating Instructions	See Contrast table(2)	11	Pad A	DHA1555
NSP 5	Polyethylene Bag	AHG7117	12	Packing Case	See Contrast table(2)
			NSP 13	Warranty Card	See Contrast table(2)
6	Pad B	DHA1556	NSP 14	Label	See Contrast table(2)
7	Pad C	DHA1557			
8	Pad D	DHA1558			

(2) CONTRAST TABLE

CDJ-800MK2/KUCXJ, /WYXJ5 and RLFXJ types are constructed the same except for the following:

Mark	No.	Symbol and Description	CDJ-800MK2/ KUCXJ	CDJ-800MK2/ WYXJ5	CDJ-800MK2/ RLFXJ
⚠	1	AC Power Cord	ADG7021	ADG1154	ADG1154
⚠	1	AC Power Cord	Not used	Not used	ADG7097
	4	Operating Instructions (English)(KUCXJ)	DRB1401	Not used	Not used
	4	Operating Instructions (WYXJ5)(English, French, German, Italian, Dutch, Spanish)	Not used	DRB1400	Not used
	4	Operating Instructions (RLFXJ) (English, Spanish, Chinese)	Not used	Not used	DRB1402
	12	Packing Case	DHG2595	DHG2594	DHG2596
NSP	13	Warranty Card	ARY7043	Not used	Not used
NSP	14	Label	DRW2311	VRW1629	VRW1629

2.2 EXTERIOR SECTION

Refer to "2.3 CONTROL PANEL SECTION".

A

B

C

D

E

F

Refer to "2.4 SLOT-IN MECHANISM SECTION".

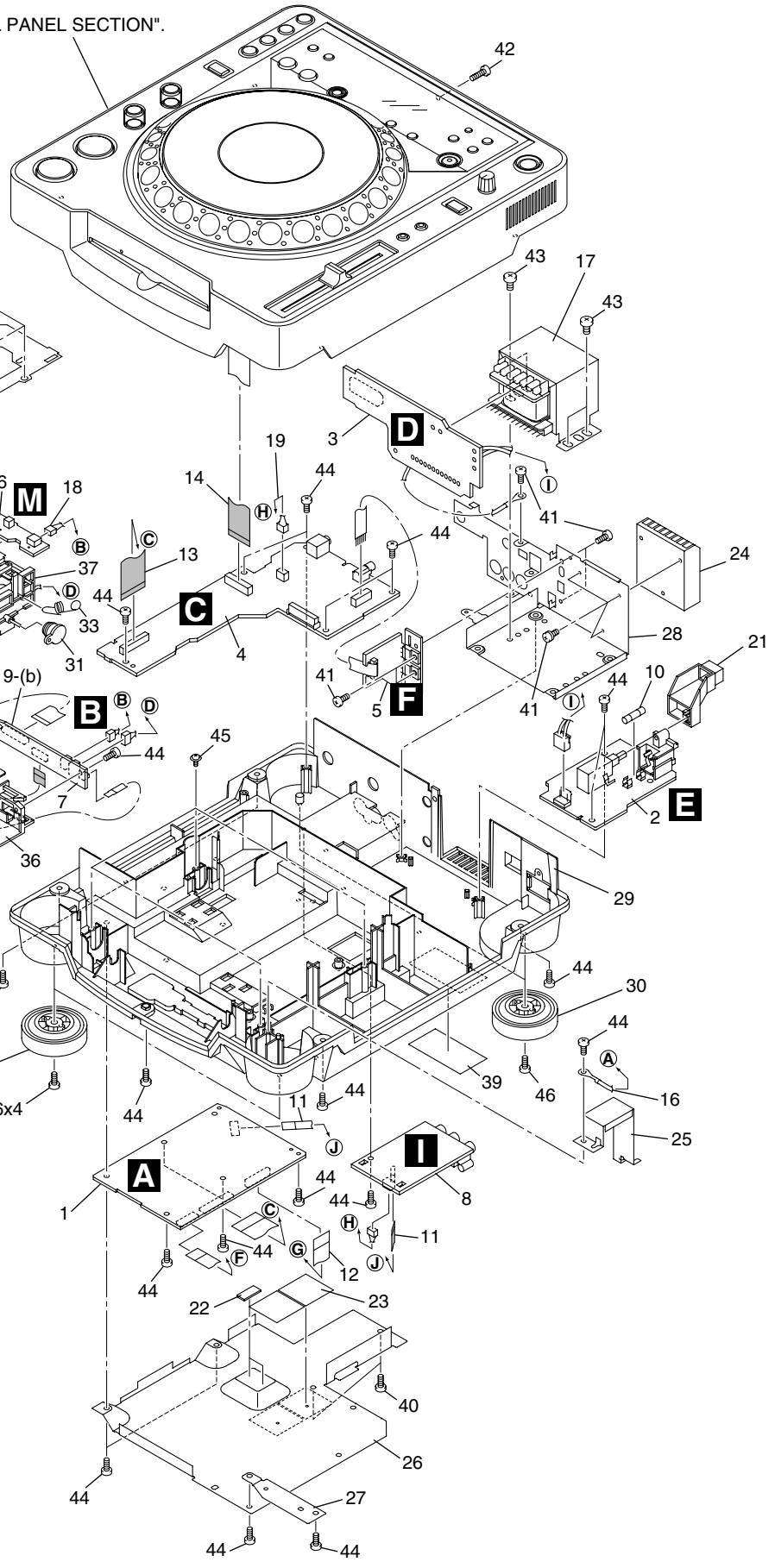
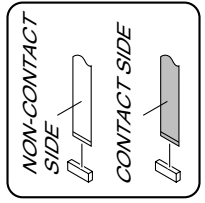

EXTERIOR SECTION parts List

<u>Mark No.</u>	<u>Description</u>	<u>Part No.</u>	<u>Mark No.</u>	<u>Description</u>	<u>Part No.</u>
1	MAIN Assy	DWG1622	25	Earth Plate	DNH2532
⚠ 2	AC IN Assy	See Contrast table(2)	26	Bottom Plate	See Contrast table(2)
⚠ 3	TRNS Assy	See Contrast table(2)	27	Bottom Earth Plate	DNH2694
4	SECB Assy	DWR1309	28	Trans Plate	DNH2733
5	REGB Assy	DWR1310	NSP 29	Chassis	See Contrast table(2)
6	SLMB Assy	DWS1388	30	Insulator Assembly	DXA2069
7	RLYB Assy	DWX2602	31	Damper	CNV6011
8	JACK Assy	DWG1626	32	Earth Spring	DBH1398
9	•••••		33	Float Spring (G5)	DBH1494
⚠ 10	Fuse	See Contrast table(2)	34	Front Sheet	DED1132
11	FFC (9p)	DDD1311	35	Mecha Plate	DNH2642
12	FFC (32p)	DDD1312	36	PCB Holder	DNK4524
13	FFC (25p)	DDD1313	37	Float Base 04 Assy	DXB1838
14	FFC (17p)	DDD1314	38	Laser Caution	See Contrast table(2)
15	FFC (24p)	DDD1315	NSP 39	Serial Label (UPC)	See Contrast table(2)
NSP 16	Earth Lead	DE010VF0	40	Screw	BBT30P060FCC
⚠ 17	Power Transfomer	See Contrast table(2)	41	Screw	BBZ30P060FTC
18	Connector Assy	PF03PP-B05	42	Screw	BBZ30P100FTC
19	Connector Assy	PF03PP-C12	43	Screw	BBZ40P060FTC
20	•••••		44	Screw	BPZ30P080FTB
21	Power Knob	DAC2073	45	DM Screw (FTC)	DBA1260
NSP 22	Silicon Lubber D5 L	DEB1456	46	Screw	IPZ30P100FTC
23	Bottom Cushion S4	DEC2506			
24	Heat Sink	DNG1102			

(2) CONTRAST TABLE

CDJ-800MK2/KUCXJ, /WYXJ5 and RLFXJ types are constructed the same except for the following:

Mark	No.	Symbol and Description	CDJ-800MK2/ KUCXJ	CDJ-800MK2/ WYXJ5	CDJ-800MK2/ RLFJ
⚠	2	AC IN ASSY	DWR1430	DWR1429	DWR1432
⚠	3	TRANS ASSY	DWR1371	DWR1371	DWR1428
⚠	10	Fuse (T1.6A)	AEK7075	Not used	Not used
⚠	10	Fuse (800MA)	Not used	REK1021	REK1021
⚠	17	Power Transfomer	DTT1204	DTT1203	DTT1203
	26	Bottom Plate	DNK2689	DNK2689	DNK2691
	29	Chassis	DNK4518	DNK4517	DNK4519
	38	Laser Caution	DRW2308	DRW2308	DRW2248
NSP	39	Serial Label	DRW2311	VRW1629	VRW1629

2.3 CONTROL PANEL SECTION



*1 Grease: GYA1001(ZLB-PN397B)

A

B

C

D

E

F

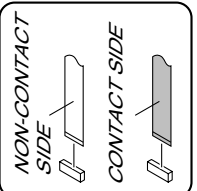
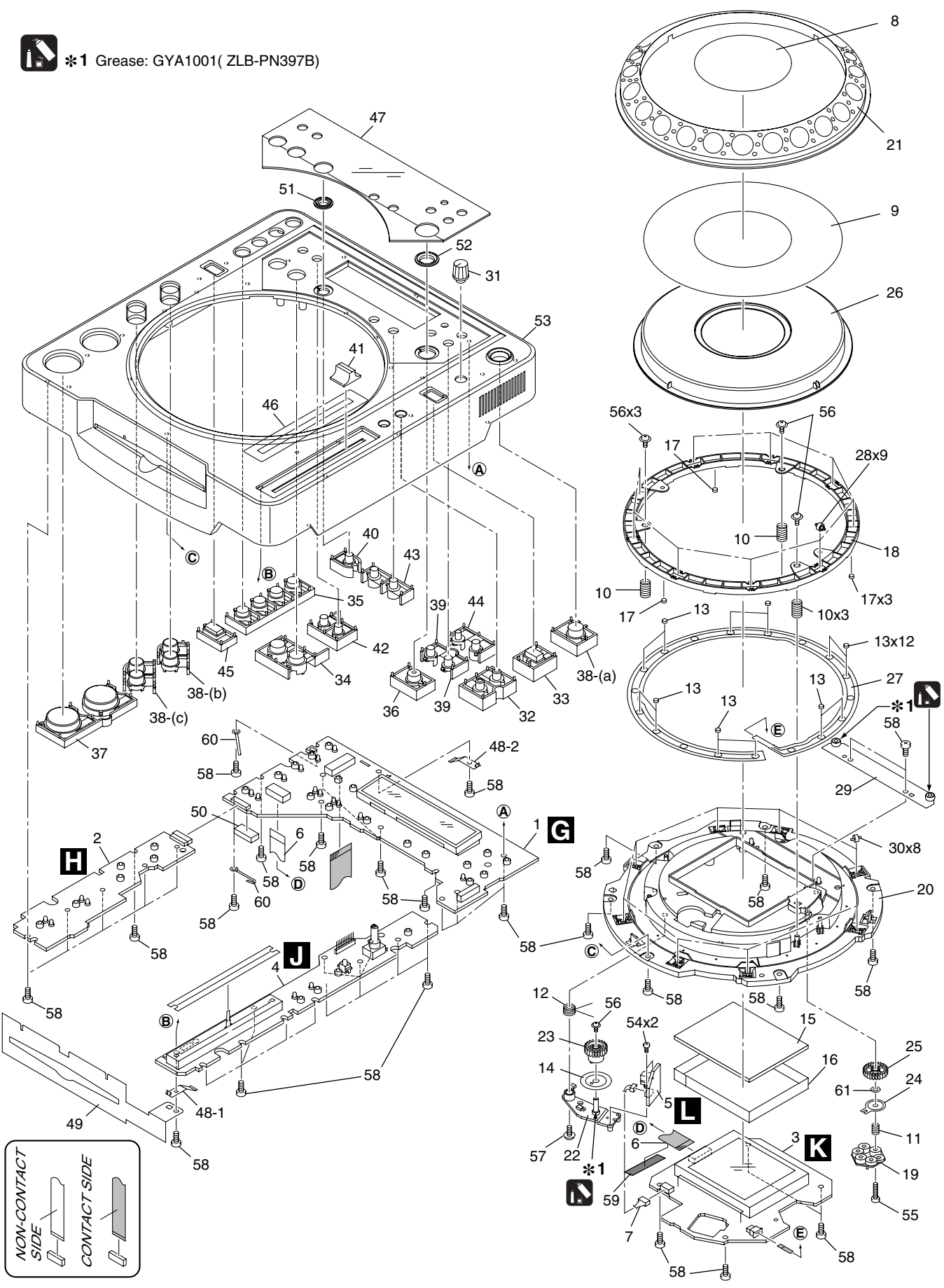

5 6
CONTROL PANEL SECTION parts List

<u>Mark No.</u>	<u>Description</u>	<u>Part No.</u>
1	DFLB Assy	DWG1623
2	KSWB Assy	DWS1386
3	JFLB Assy	DWG1624
4	SLDB Assy	DWS1387
5	JOGB Assy	DWG1625
6	FFC	DDD1220
7	Connector Assy	PF04PP-B07
8	Jog Panel (PMMA)	DAH2182
9	Jog Plate	DAH2438
10	SW spring 25	DBH1514
11	Gear spring 200	DBH1525
12	ARM Spring	DBH1566
13	SW Cushion HH48/2	DEC2538
14	Encoder Plate	DEC2889
15	Protector Sheet	DEC2945
16	FL Sheet	DEC2946
17	Ring Cushion L24/2.0	DEC2958
18	SW Ring	DNK4070
19	Adjust Plate	DNK4178
20	Jog Holder	DNK4545
21	Jog B	DNK4557
22	Gear ARM	DNK4559
23	Gear	DNK4560
24	Smoother	DNK4561
25	Load Gear A	DNK4562
26	Jog A	DNK4586
27	Sheet SW	DSX1065
28	Roller A Assy	DXB1825
29	Jog Stay Assy	DXB1876
30	Roller B Assy	DXB1877
31	Rotary Knob C	DAA1194
32	TEMPO Knob	DAC2061
33	VINYL Knob	DAC2063
34	LOOP Knob	DAC2066
35	Auto Beat Loop Knob	DAC2069
36	Quick Return Knob	DAC2070
37	PLAY Knob	DAC2286
38	Set Knob (Eject)	DAC2287
39	CALL Knob	DAC2289
40	RELOOP Knob	DAC2291
41	Slide Knob	DAC2292
42	TEXT/A.CUE Knob	DAC2294
43	Folder Search Knob	DAC2298
44	DEL/MEMO Knob	DAC2299
45	Reverse Knob	DAC2364
46	Slide Sheet (gray)	DAH2374
47	Display Panel	DAH2418
48	Earth Plate (CU)	DBK1224
49	Vessel Sheet	DEC2495

<u>Mark No.</u>	<u>Description</u>	<u>Part No.</u>
50	FFC Guard	DEC2586
51	Reloop Guard	DNK4057
52	Q R Guard	DNK4058
53	Control Panel	DNK4525
54	Screw	BPZ20P060FTC
55	Screw	BPZ20P100FTC
56	Screw (FE)	DBA1265
57	Screw	IPZ30P100FTC
58	Screw	BPZ30P080FTB
59	Ecsane Tape (10x50)	DEC2988
60	Cord Clamper	RNH-184-0
61	Washer	WA42D080D050

2.4 SLOT-IN MECHANISM SECTION

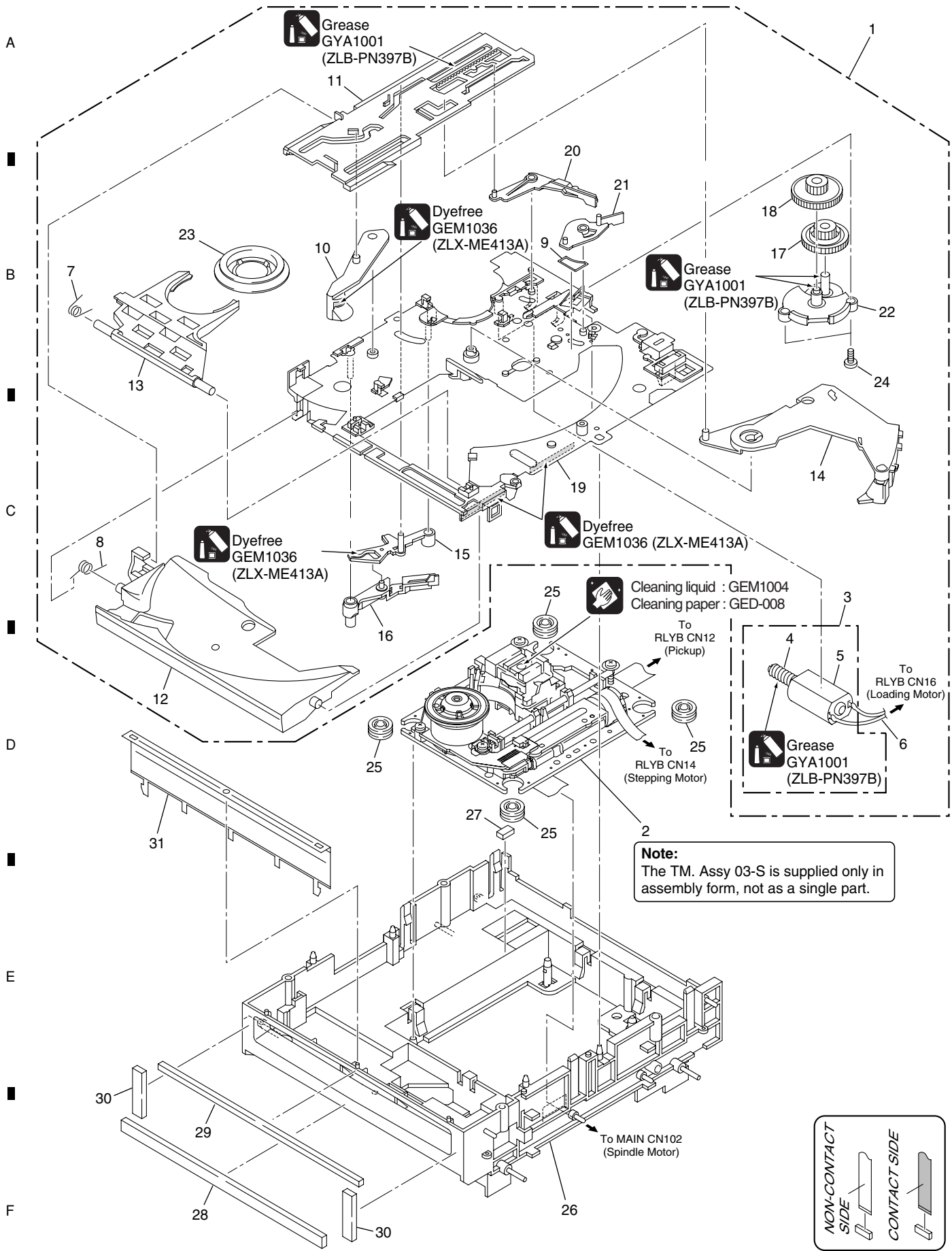

5 6 7 8

SLOT-IN MECHANISM SECTION parts List

<u>Mark No.</u>	<u>Description</u>	<u>Part No.</u>
NSP 1	Slot-in Mecha SV Assy	DXA2005
2	TM. Assy 03-S	VXX3125
3	Loading Motor Assy-S	DXX2510
NSP 4	Worm Gear	DNK3910
NSP 5	DC Motor S (ROHS)	DXM1230
6	Connector Assy	PF02PY-B22
7	Clamp Spring	DBH1374
8	Guide Spring	DBH1375
9	SW Lever Spacer SV	DEC2831
10	Loading Lever	DNK3406
11	Main Cam	DNK3407
12	Disc Guide	DNK3478
13	Clamp Arm	DNK3576
14	Eject Lever	DNK3684
15	Lever AP	DNK3835
16	Lever BP	DNK3836
17	Loading Gear	DNK3911
18	Drive Gear	DNK3912
19	Loading Base SV	DNK4369
20	SW Lever SV1	DNK4370
21	SW Lever SV2	DNK4371
22	Gear Holder SV	DNK4372
23	Clamper 04 Assy	DXB1859
24	Screw	BPZ20P060FTC
25	Floating Rubber (SI)	VEB1351
26	Float Base 04 Assy	DXB1838
27	Spacer POR (T3)	DEB1566
28	Vessel Cushion A	DEC2852
29	Vessel Cushion B	DEC2853
30	Vessel Cushion C	DEC2854
31	Front Sheet	DED1132

A

B

C

D

E

F

3. BLOCK DIAGRAM AND SCHEMATIC DIAGRAM

3.1 BLOCK DIAGRAM

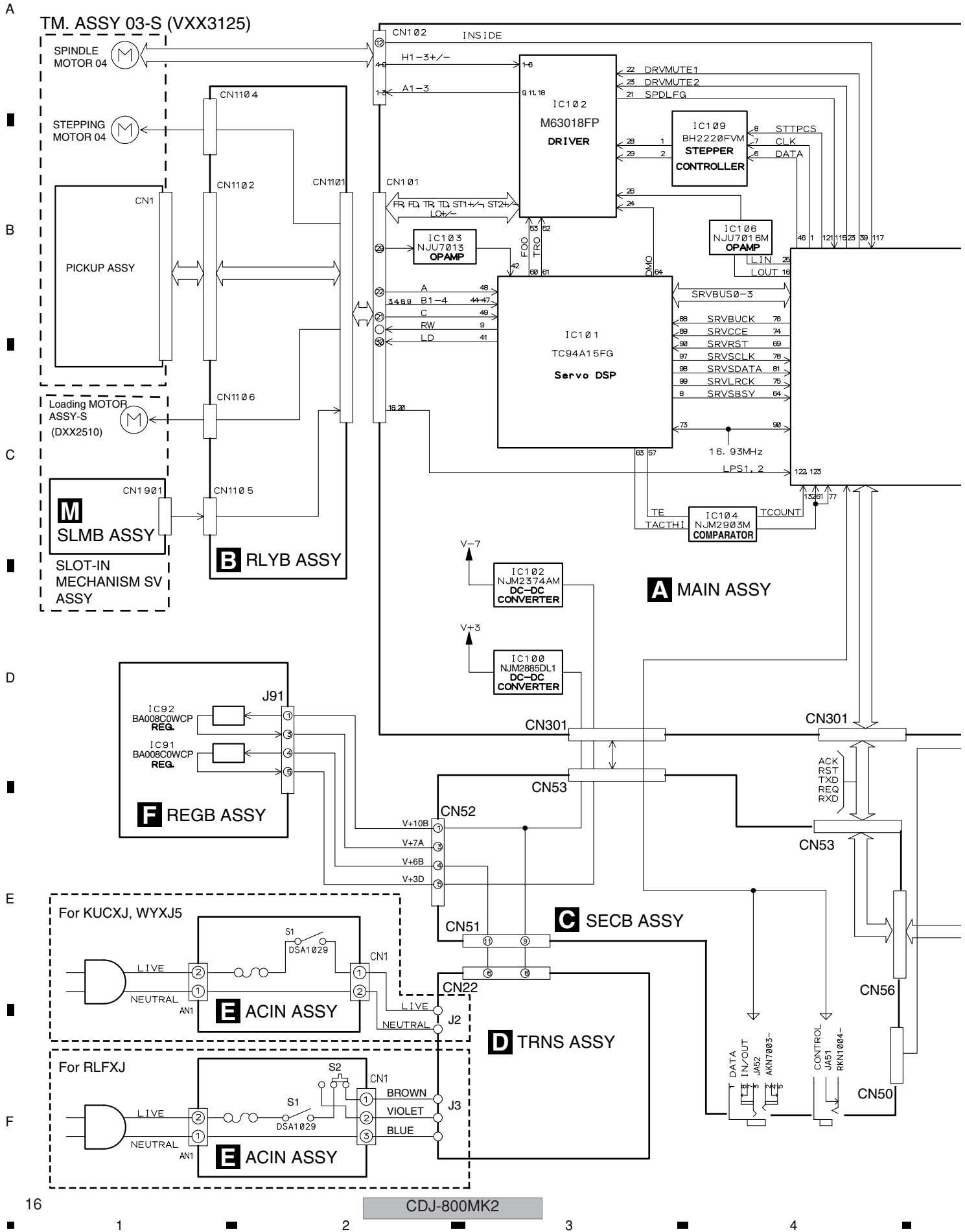

A MAIN ASSY

- When ordering service parts, be sure to refer to "EXPLODED VIEWS and PARTS LIST" or "PCB PARTS LIST".
- The ⚠ mark found on some component parts indicates the importance of the safety factor of the part. Therefore, when replacing, be sure to use parts of identical designation.
-  : The power supply is shown with the marked box.

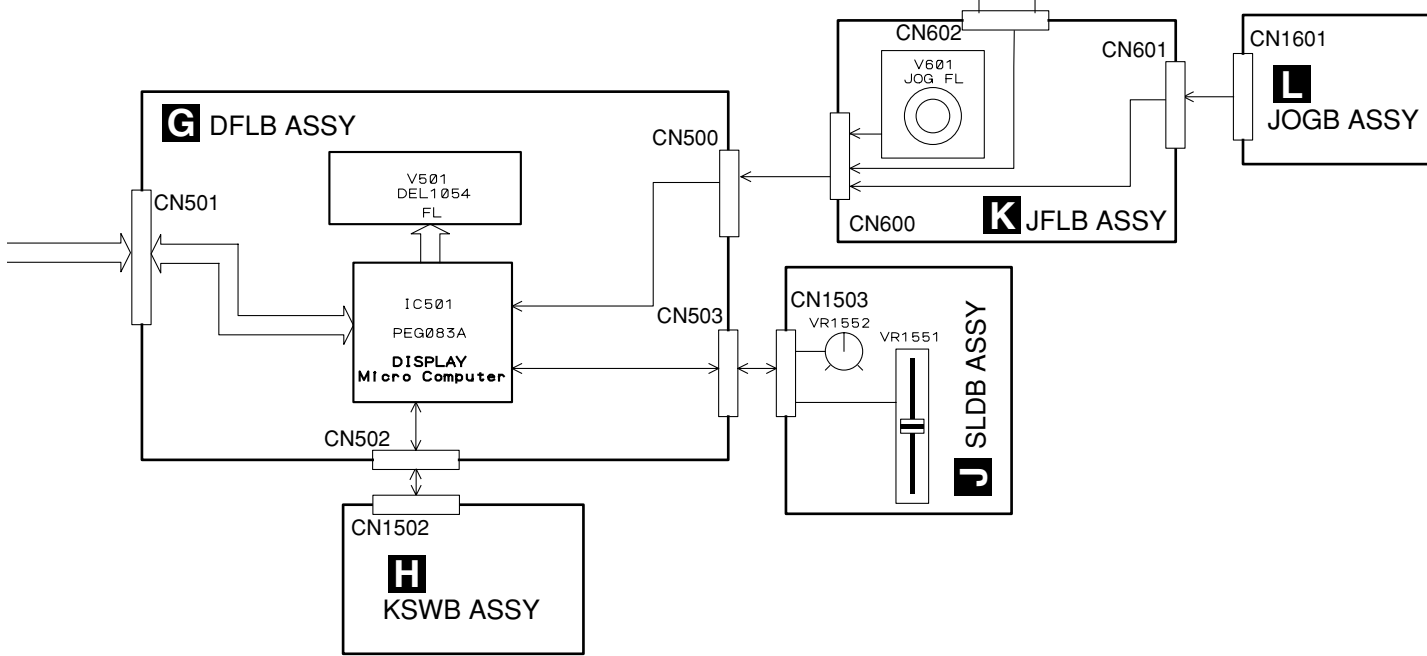
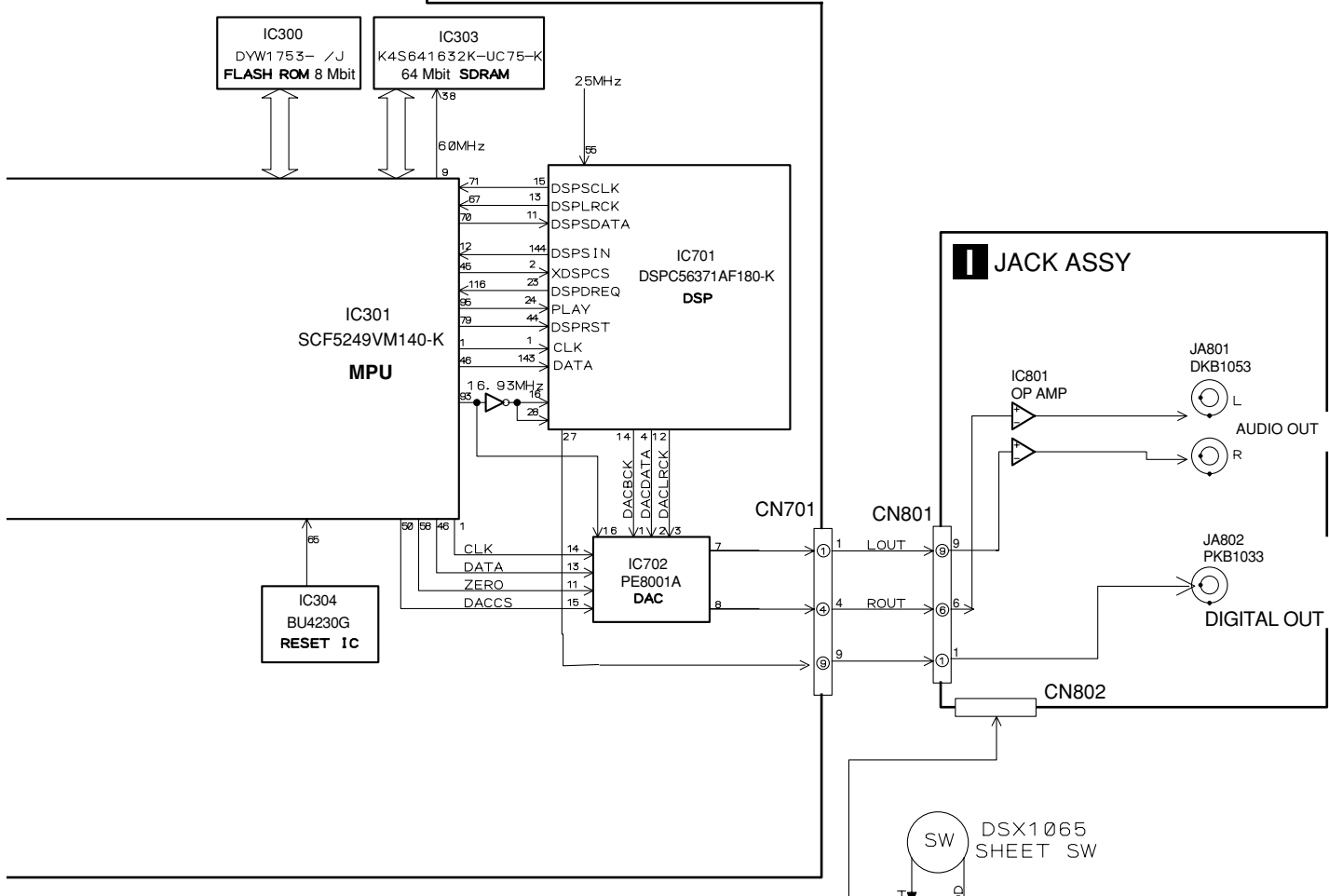

3.2 BLOCK DIAGRAM (2)

• Block Diagram Map

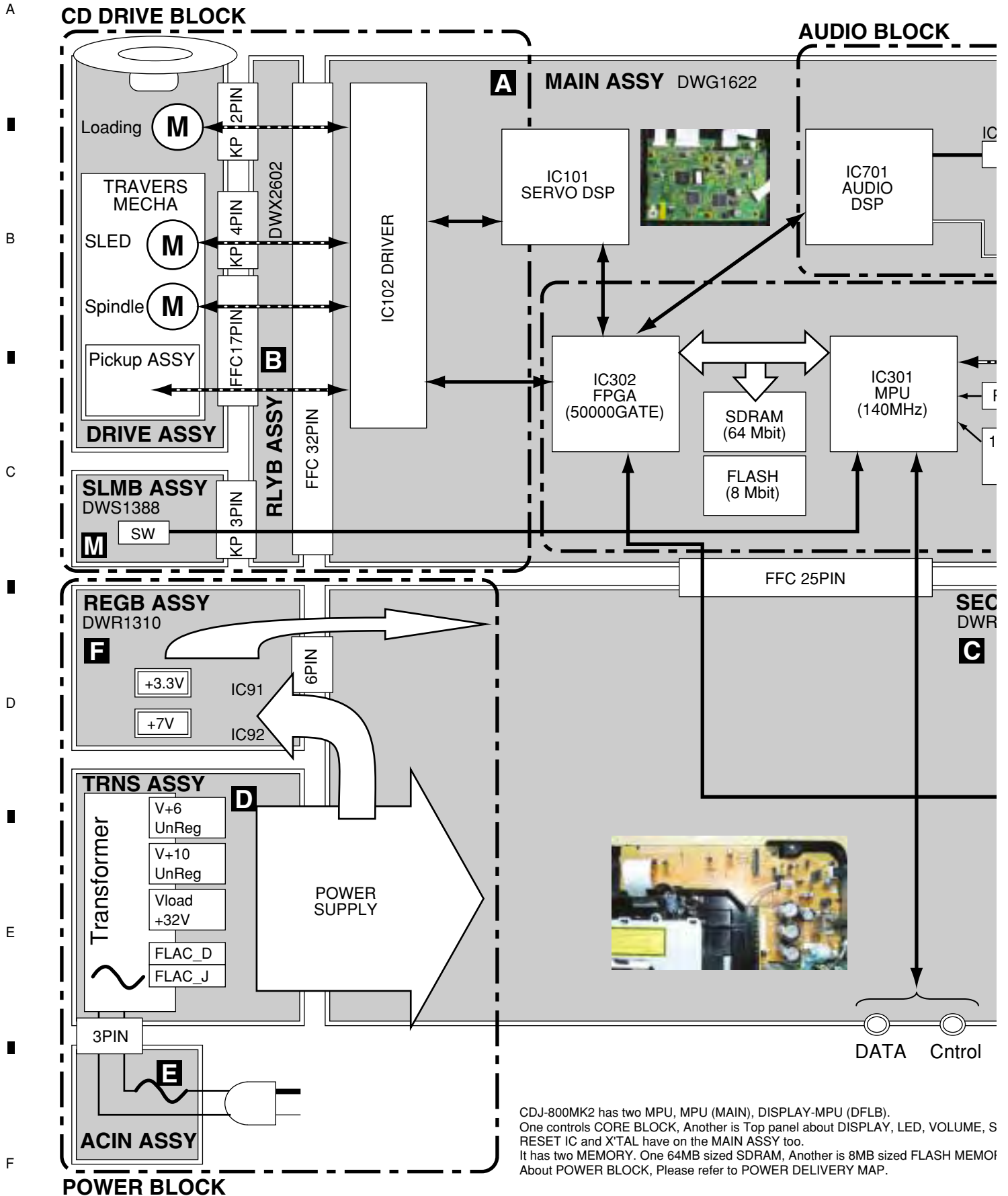

IO BLOCK

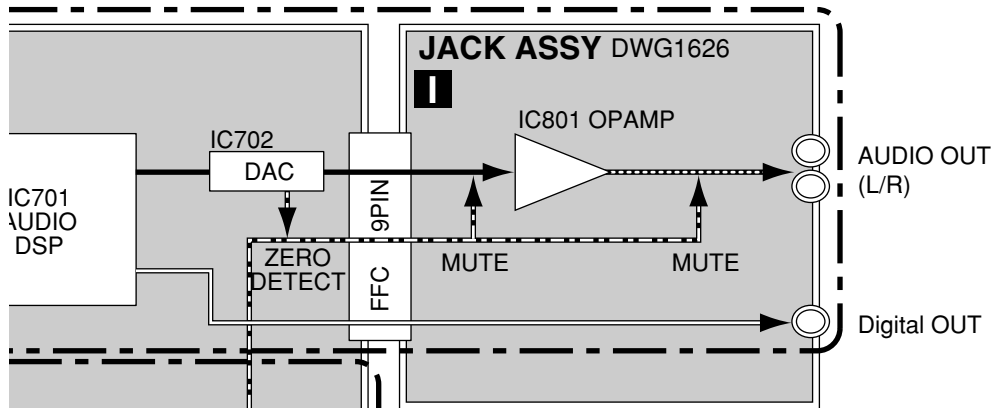

- AUDIO OUT LINE
- ===== DIGITAL OUT LINE
- - - - - AUDIO MUTE LINE
- CONTROL LINE
- DRIVE CONTROL

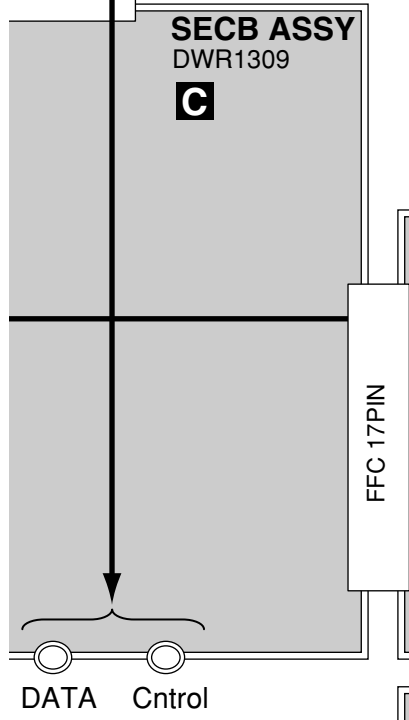
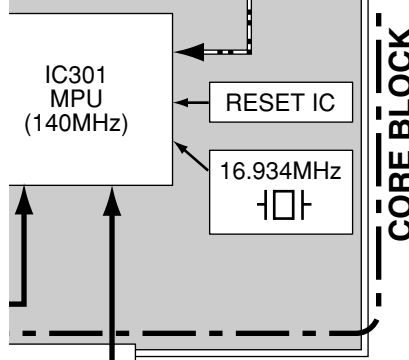

(DFLB),
ISPLAY, LED, VOLUME, SW, JOG, etc.
8MB sized FLASH MEMORY.
Y MAP.

PANEL BLOCK

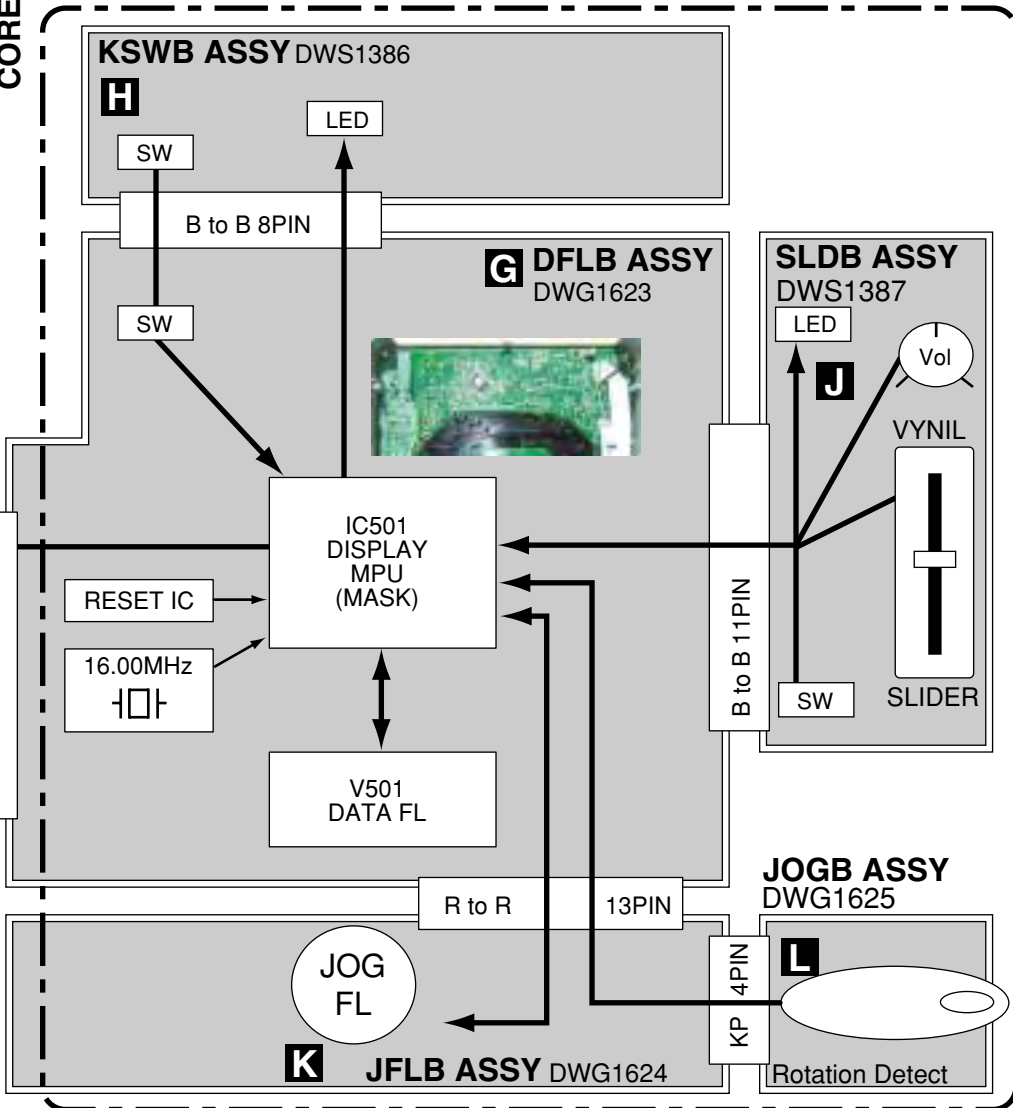

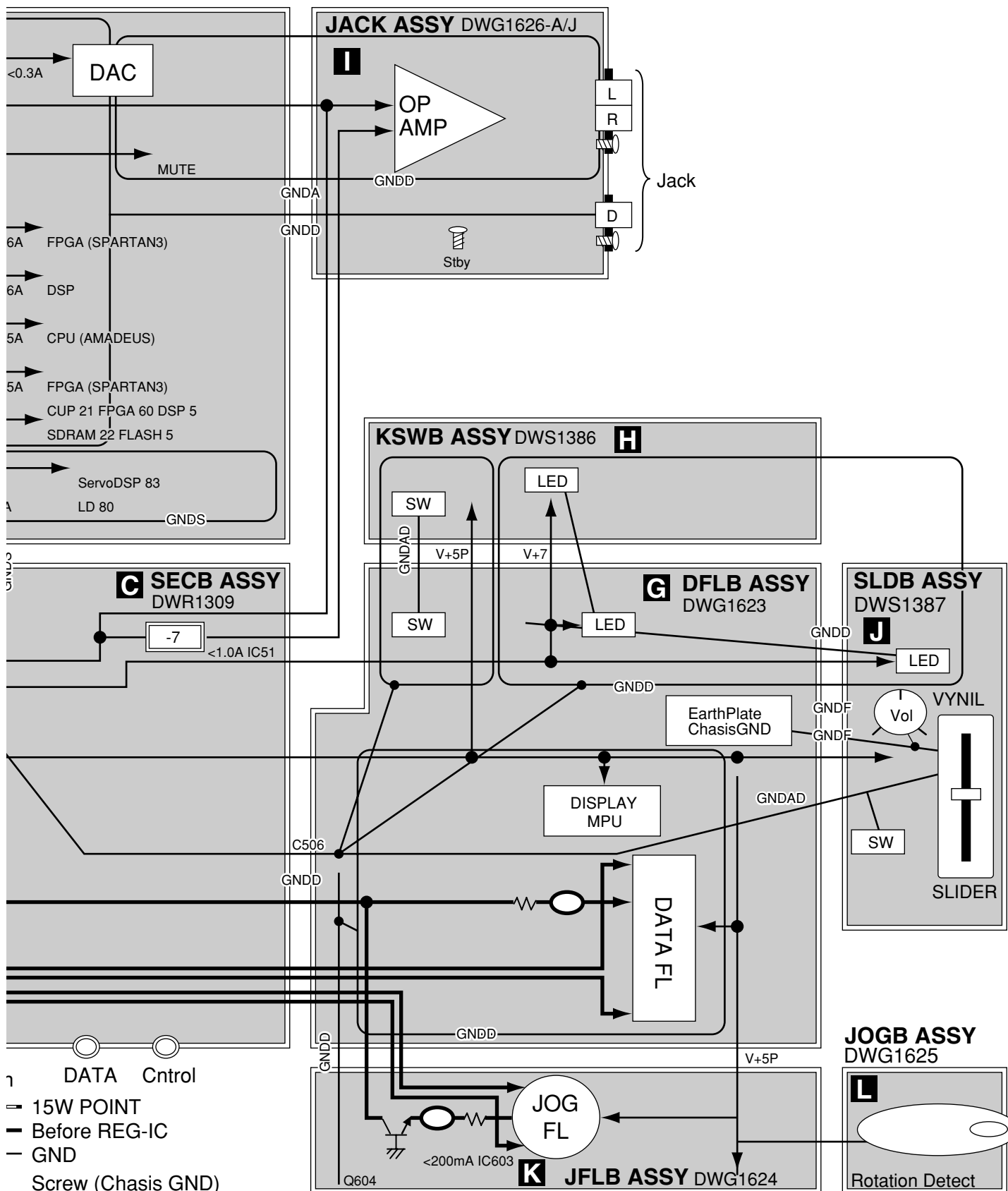

3.4 OVERALL WIRING DIAGRAM

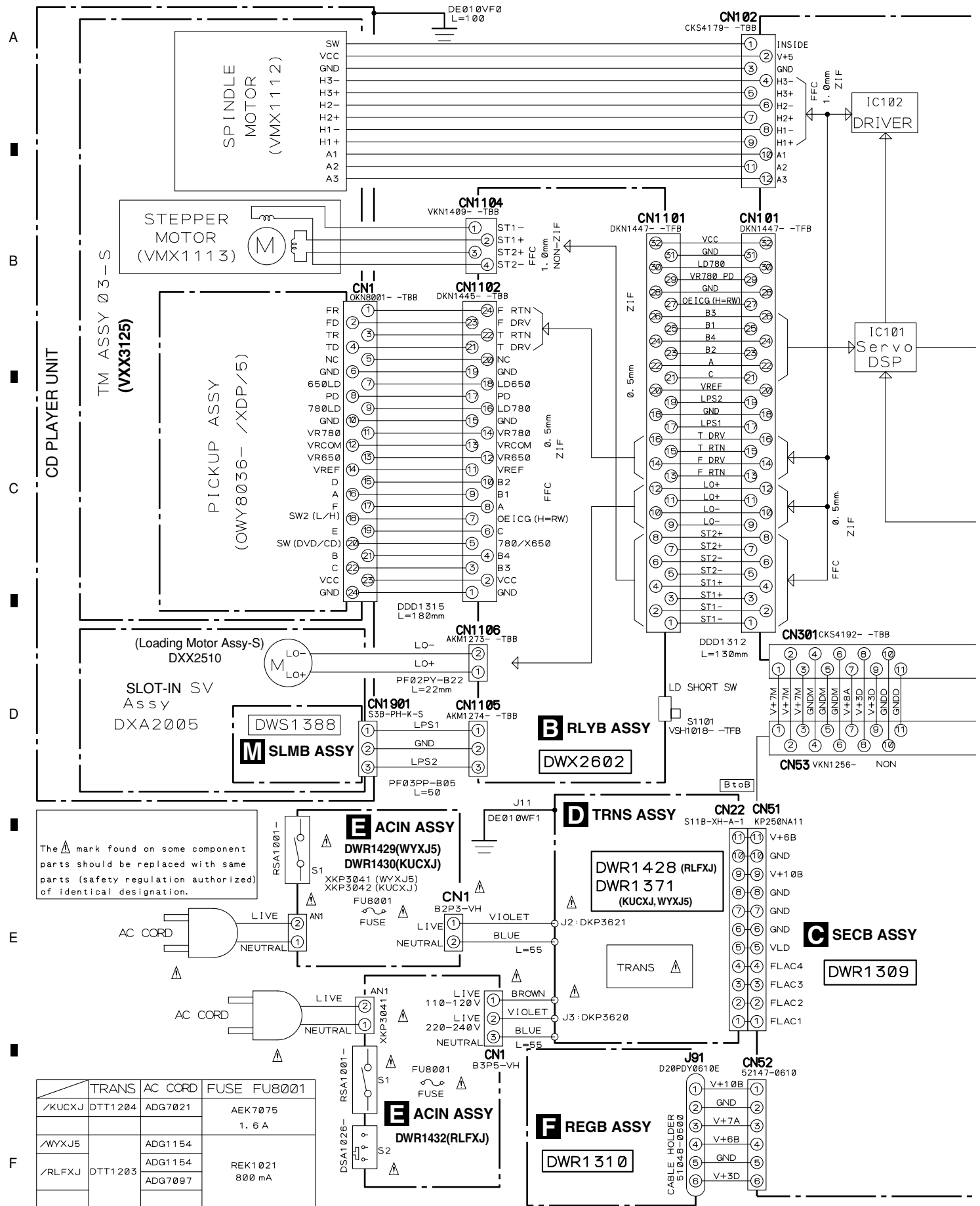

	TRANS	AC CORD	FUSE FU8001
/KUCXJ	DTT1204	ADG7021	AEK7075 1.6 A
/WYXJ5		ADG1154	
/RLFXJ	DTT1203	ADG1154 ADG7097	REK1021 800 mA

A MAIN ASSY
(**A1/3 - A3/3**)

DWG1622

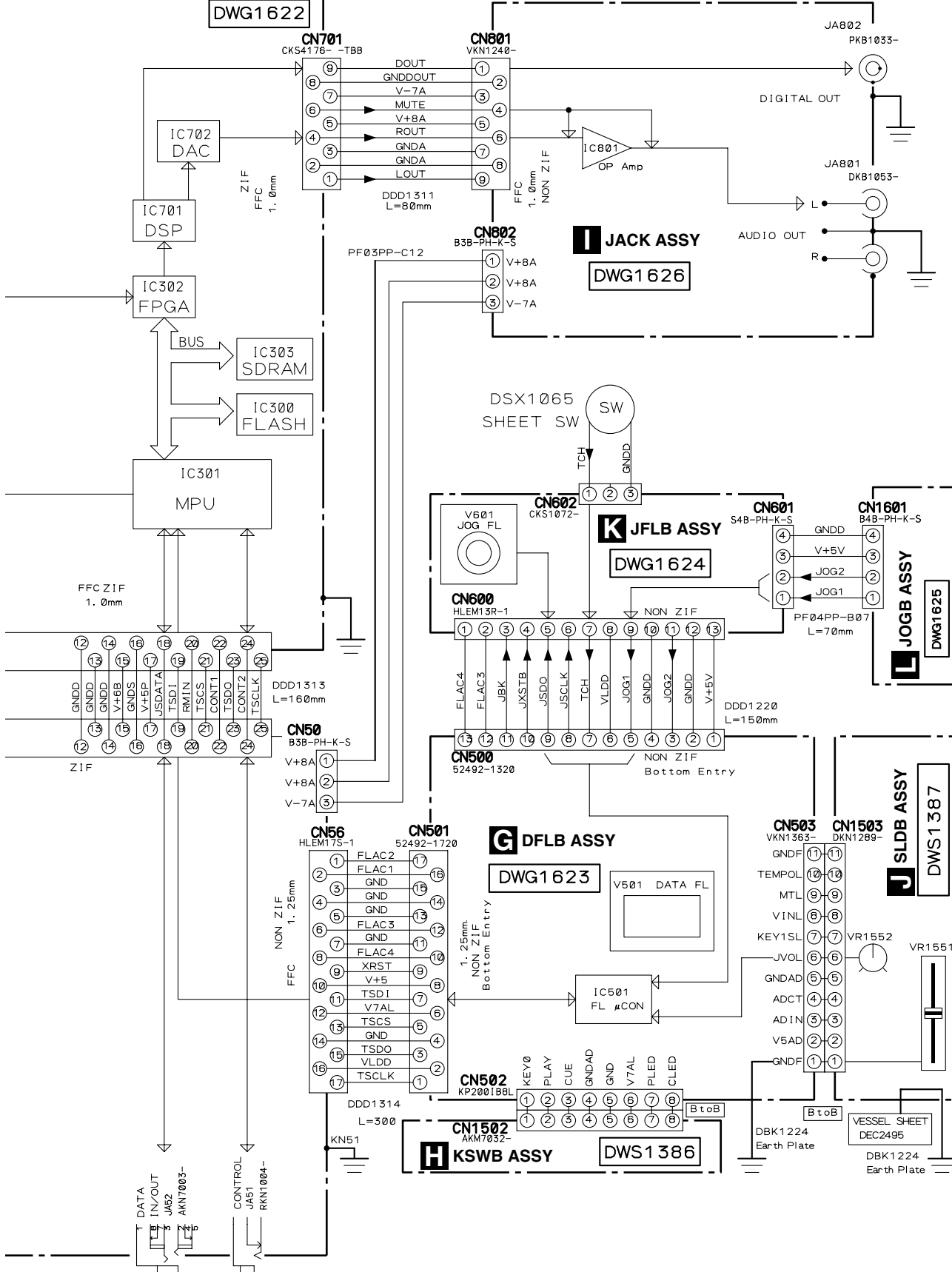

A
B
C
D
E
F

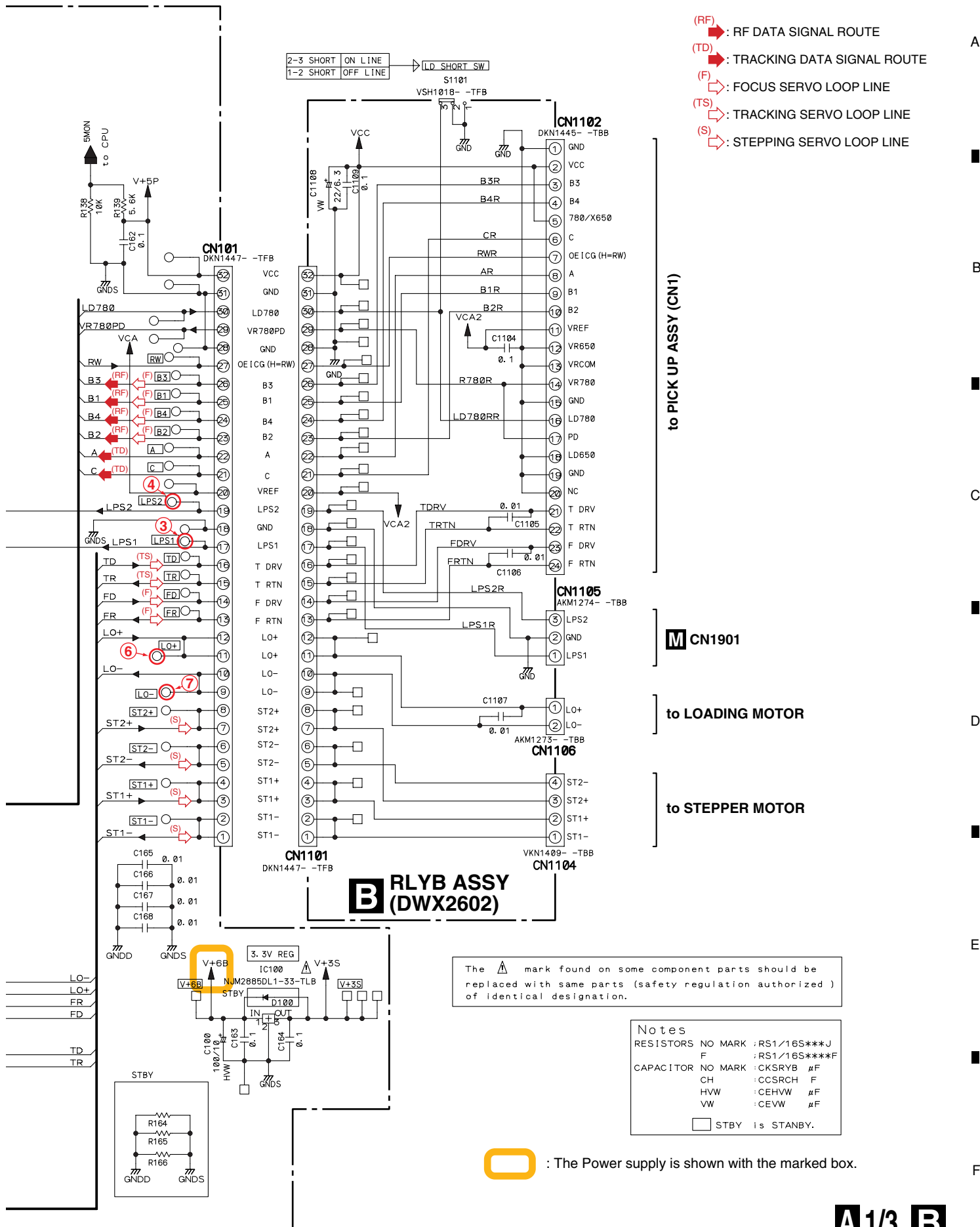

- (RF) → RF DATA SIGNAL ROUTE
- (TD) → TRACKING DATA SIGNAL ROUTE
- (F) → FOCUS SERVO LOOP LINE
- (TS) → TRACKING SERVO LOOP LINE
- (S) → STEPPING SERVO LOOP LINE

to PICK UP ASSY (CN1)

M CN1901

to LOADING MOTOR

to STEPPER MOTOR

B RLYB ASSY (DWX2602)

The Δ mark found on some component parts should be replaced with same parts (safety regulation authorized) of identical designation.

Notes

RESISTORS NO MARK	:RS1/16S***J
F	:RS1/16S***F
CAPACITOR NO MARK	:CKSRYB μ F
CH	:CCSRCH F
HVW	:CEHVW μ F
VW	:CEVW μ F

STBY is STANBY.

 : The Power supply is shown with the marked box.

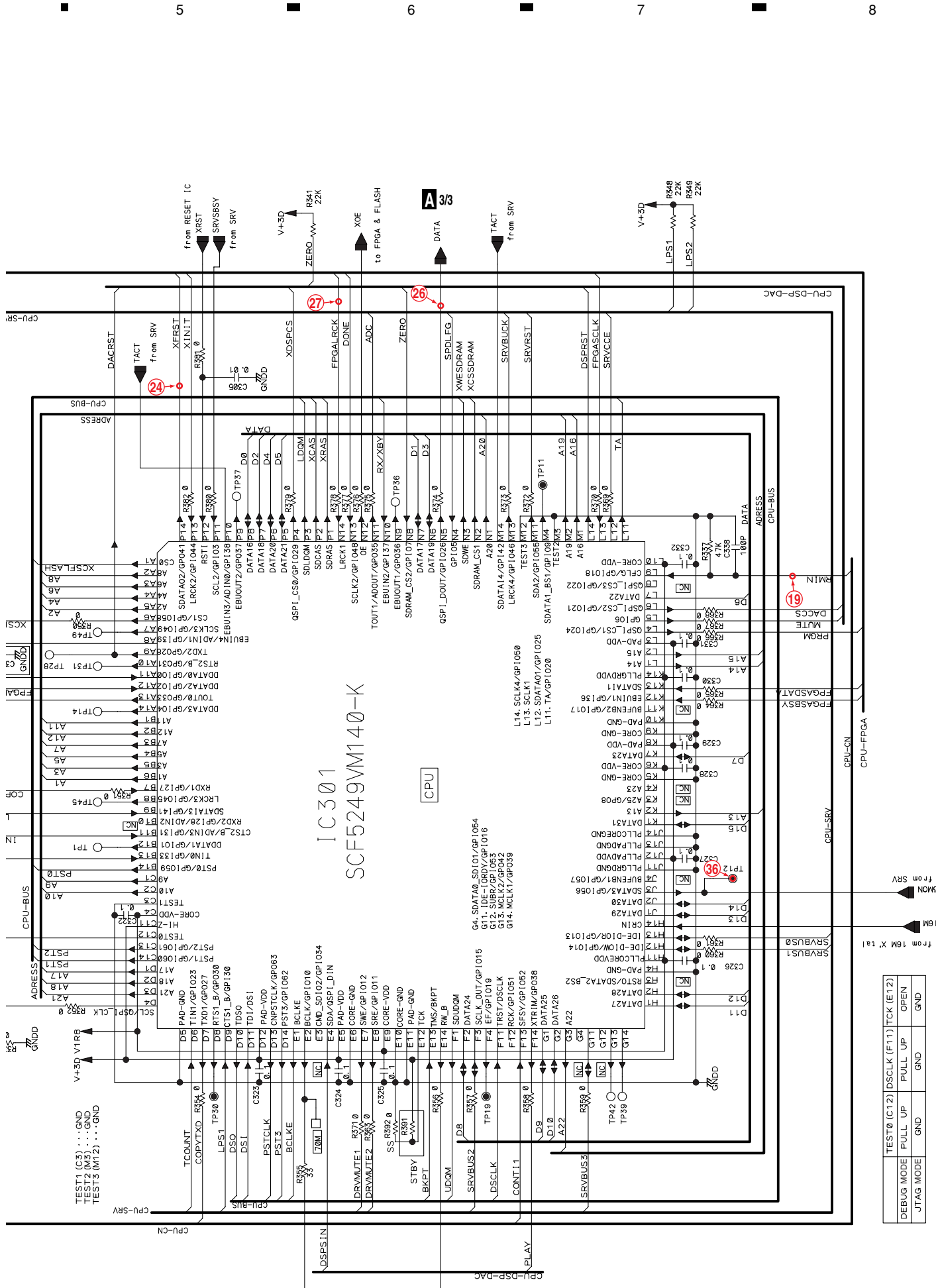

IC301
SCF5249VM140-K

CPU

TEST0 (C12)	DSCLK (F11)	TCK (E12)
DEBUG MODE	PULL UP	PULL UP
JTAG MODE	GND	GND

CDJ-800MK2

A 2/3 MAIN ASSY (DWG1622) (2/2)

B

C

D

E

F

Large size SCH diagram

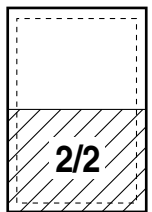
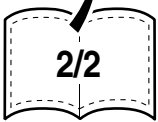
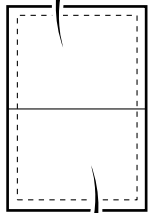
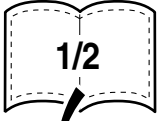

Notes
 RESISTORS NO MARK :RS1/16S***J
 F :RS1/16S***F
 SS :RS1/16SS***J
 CAPACITOR NO MARK :CKSPYB #F
 CH :CCSRCH #F
 HWW :CERWV #F
 STBY is STANBY.

Ⓜ : The Power supply is shown with the marked box.

The **Ⓜ** mark found on some component parts should be replaced with same parts (safety regulation authorized) of identical designation.

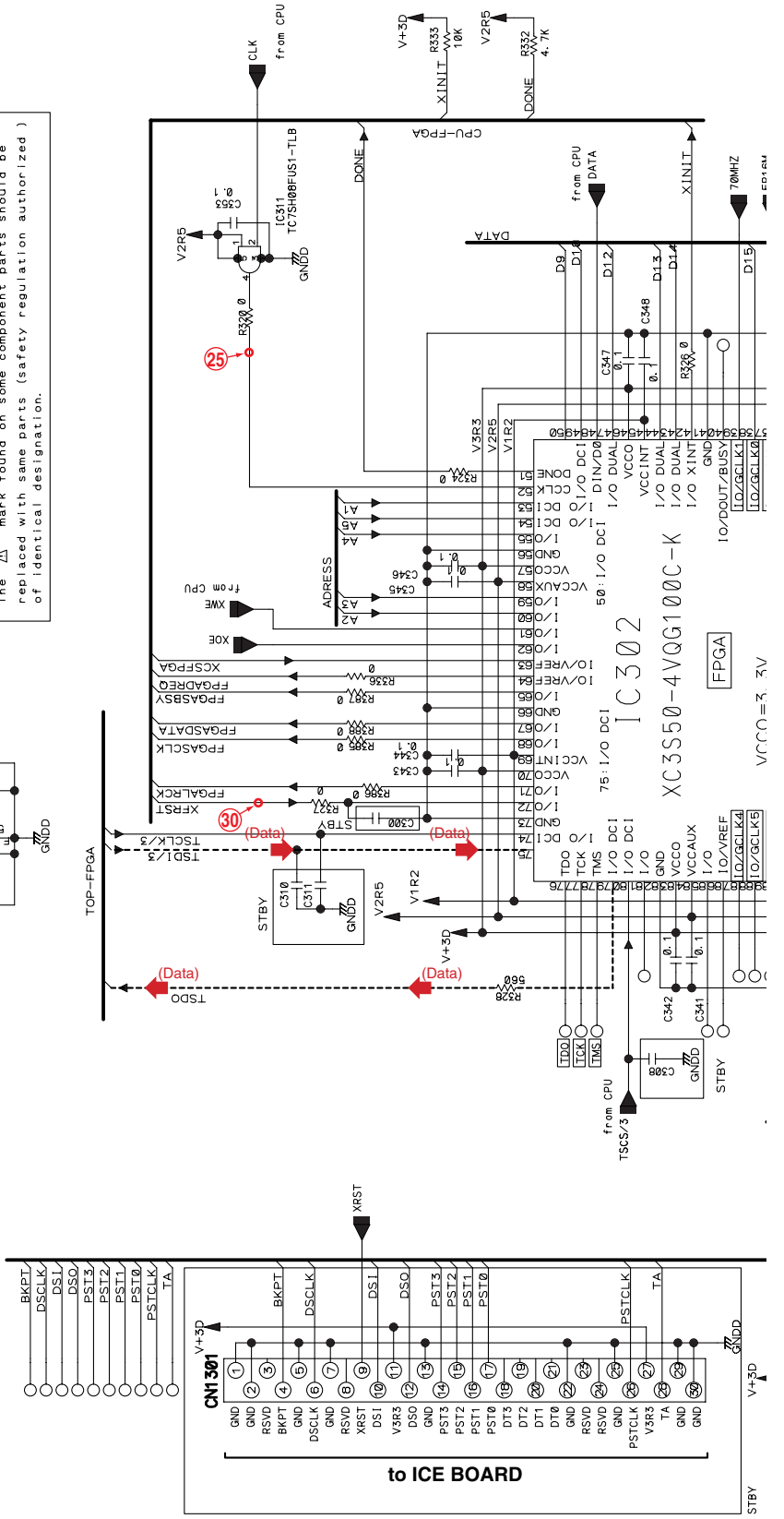
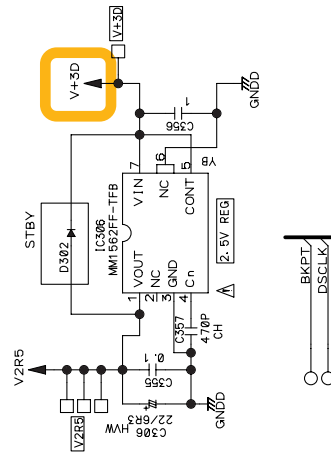
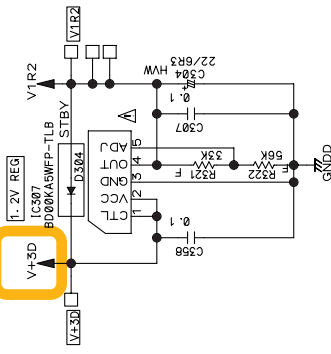

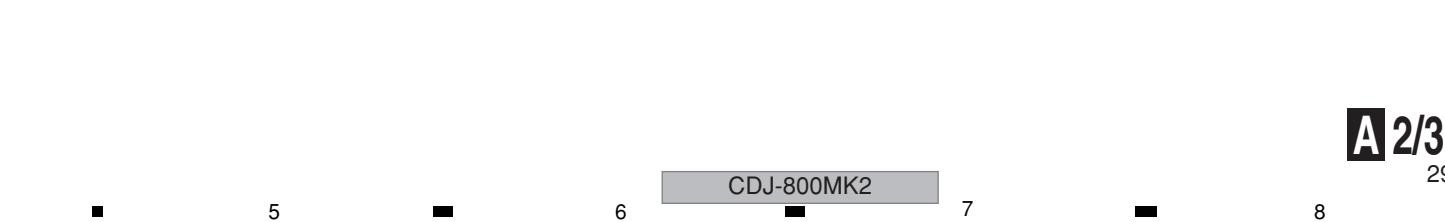
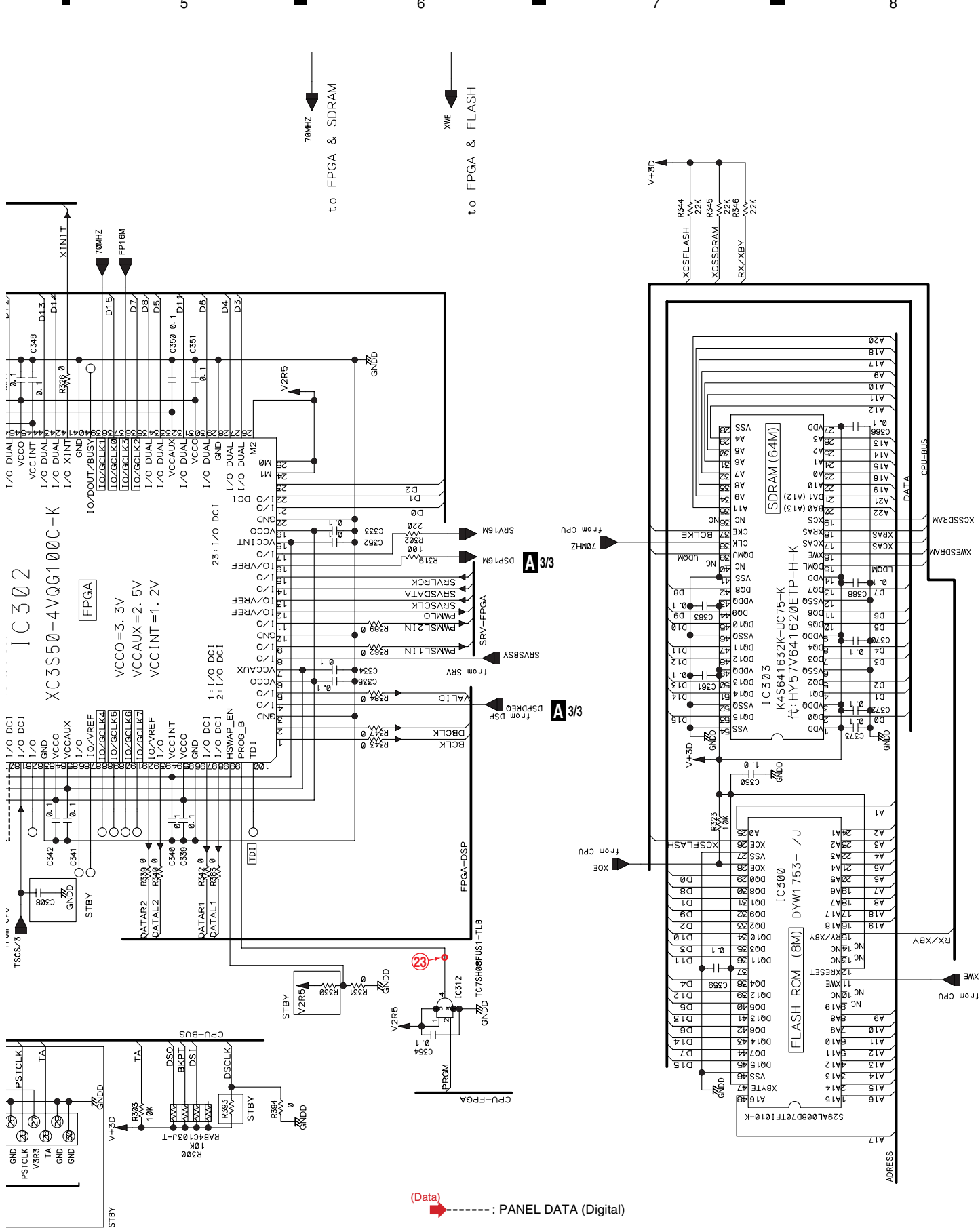

(Data) → : PANEL DATA (Digital)

3.7 MAIN ASSY(3/3)

A 3/3 MAIN ASSY (DWG1622)

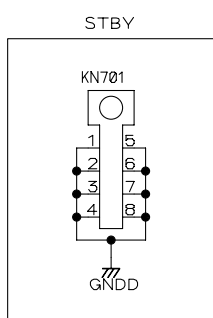
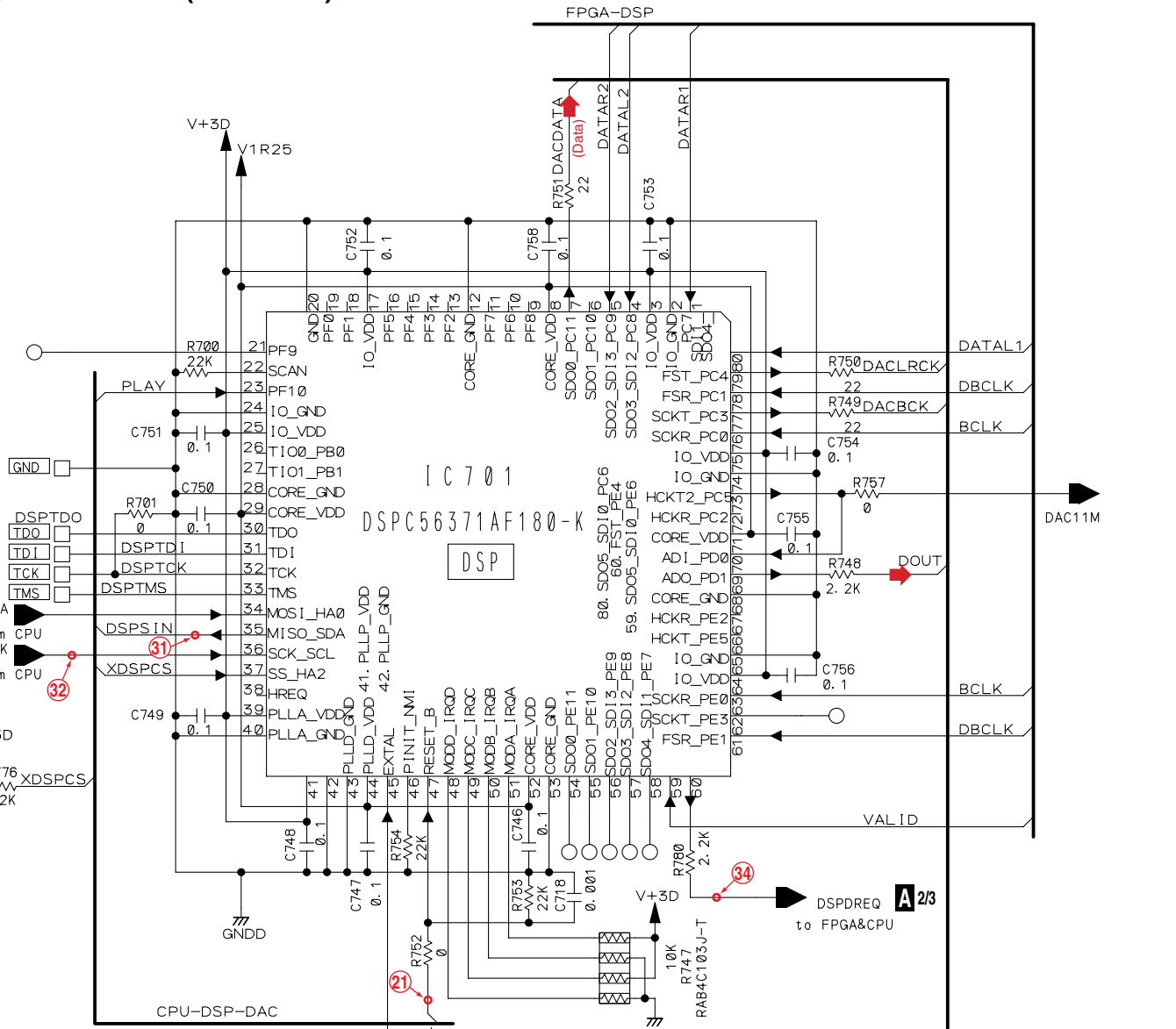



Notes

RESISTORS	NO MARK	:RS1/16S***J
	F	:RS1/16S****F
CAPACITOR	NO MARK	:CKSRYB #F
	CH	:CCSRCH F
	HWV	:CEHWV #F

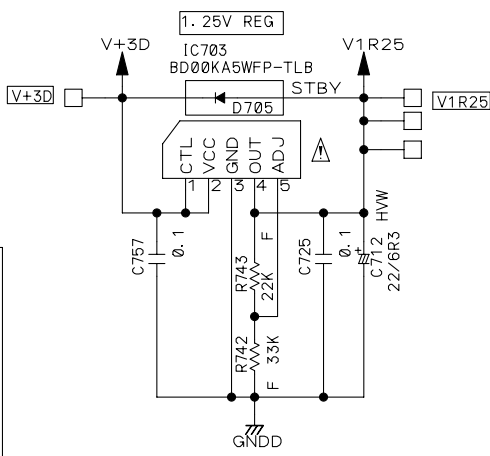

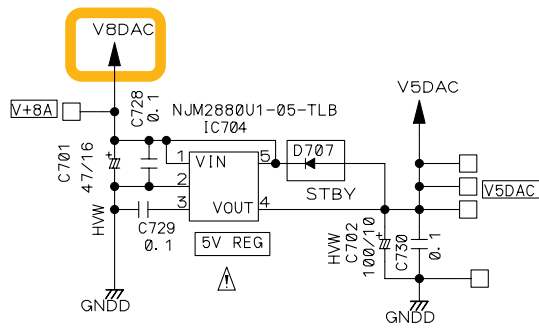
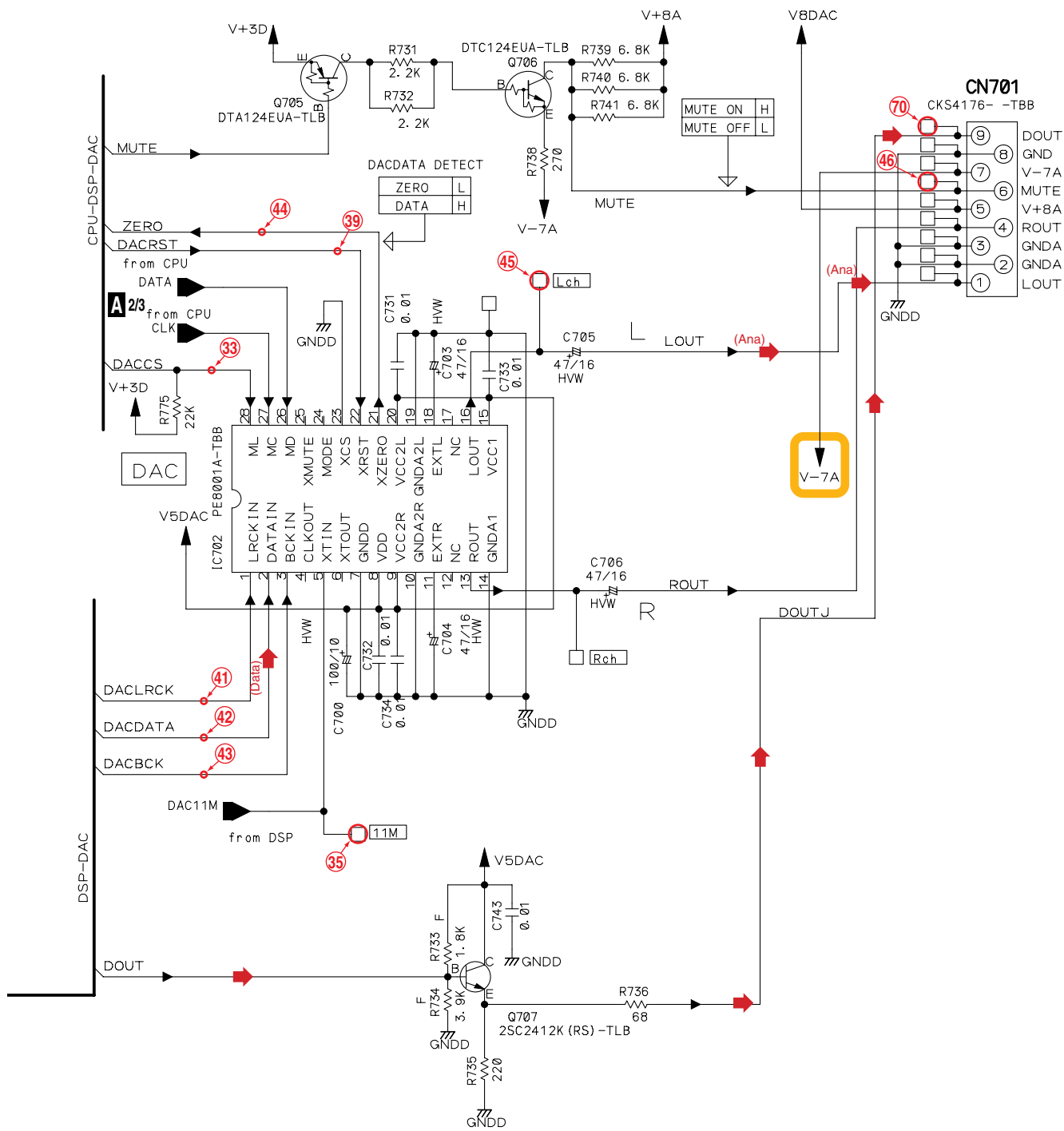
□ STBY is STANBY.





The  mark found on some component parts should be replaced with same parts (safety regulation authorized) of identical designation.

 : The Power supply is shown with the marked box.

-  (Data) : AUDIO DATA (Digital)
-  (Ana) : AUDIO Lch OUT (Analog)
-  : DATA AUDIO OUT (Digital)

3.8 AC IN, TRNS, SECB and REGB ASSYS

A
B
C
D
E
F

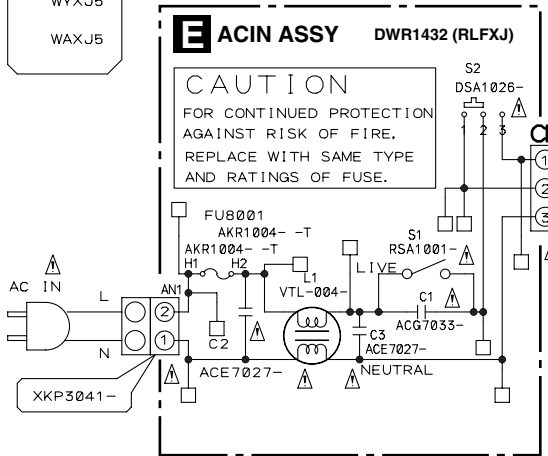
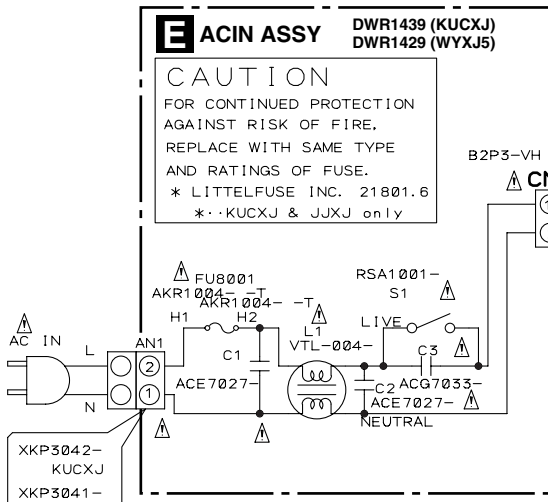

The mark found on some component parts should be replaced with same parts (safety regulation authorized) of identical designation.

Notes

RESISTOR

VM : RD1/2VM***J Ω

F : RS1/16S***F Ω

NO MARK : RS1/16S***J Ω

CAPACITOR

NO MARK : CKSRYB #F

CH : CCSRCH F

HAT : CEHAT μF

HAR : CEHAR μF

is STANBY

STBY

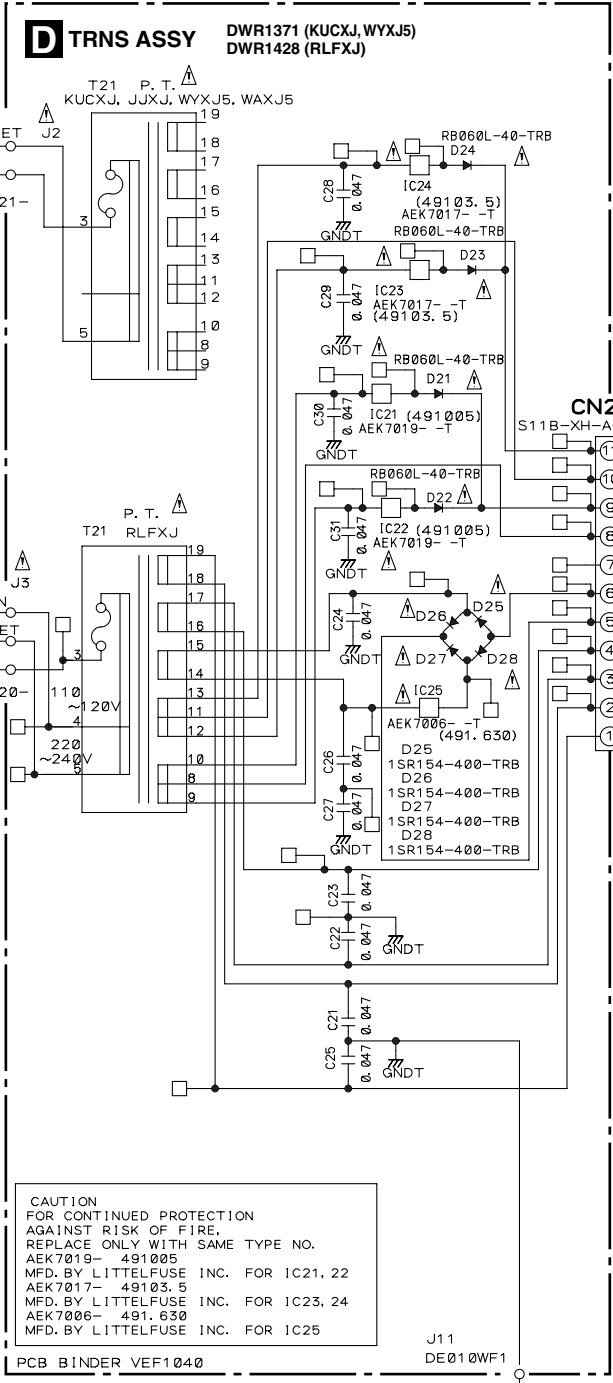

	KUCXJ	WYXJ5	RLFXJ
ASSY	DWM2234	DWM2233	DWM2236
TRNS	DWR1371	DWR1371	DWR1428
AC IN	DWR1430	DWR1429	DWR1432
S2	AKR1004	AKR1004	AKR1004
AN1	XKP3042	XKP3041	XKP3041
TRANS	DTT1204	DTT1203	←
AC CORD	ADG7021	ADG1154	ADG1154- ADG7097-
	1.6A	0.8A	0.8A
FU8001	AEK7075	REK1021	REK1021
J2	DKP3621	DKP3621	DKP3621
J3	DKP3621	DKP3621	DKP3620
CN1	B2P3-VH	B2P3-VH	B3P5-VH



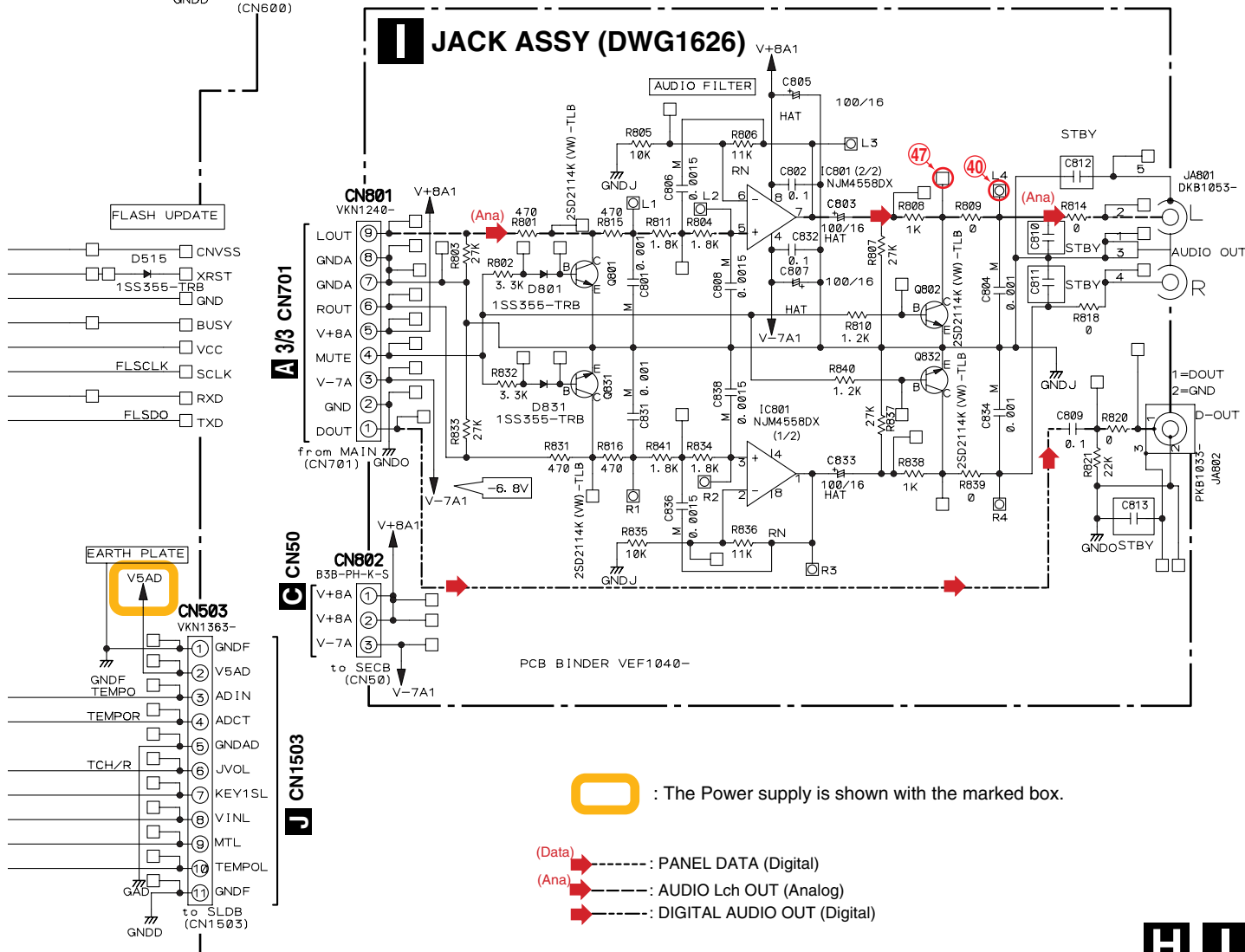
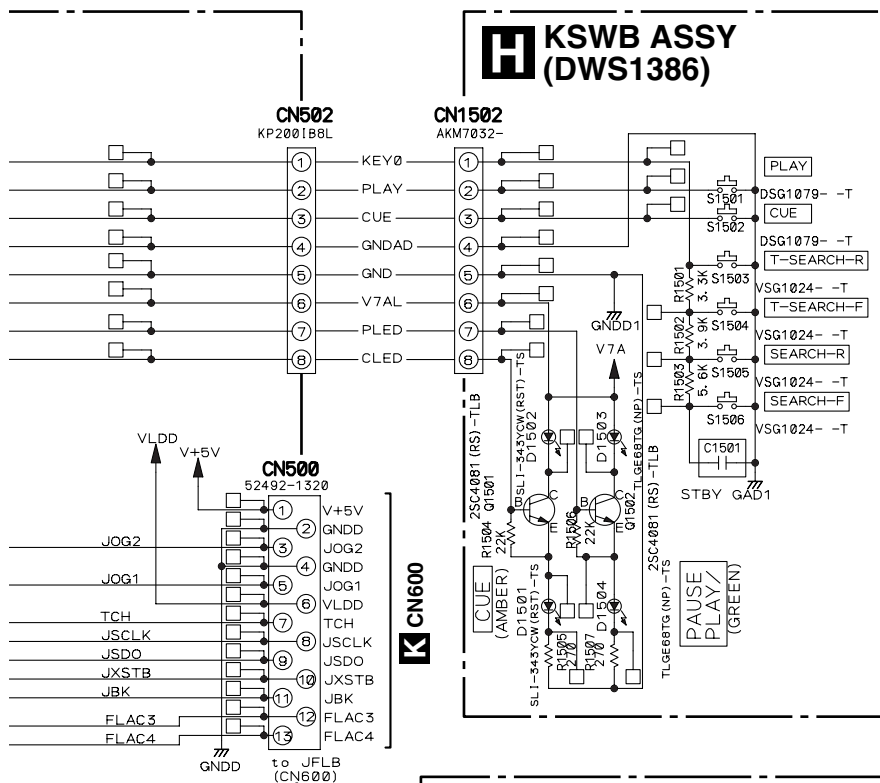

A

B

C

D

E

F



3.10 JFLB, SLDB, SLMB and JOGB ASSYS

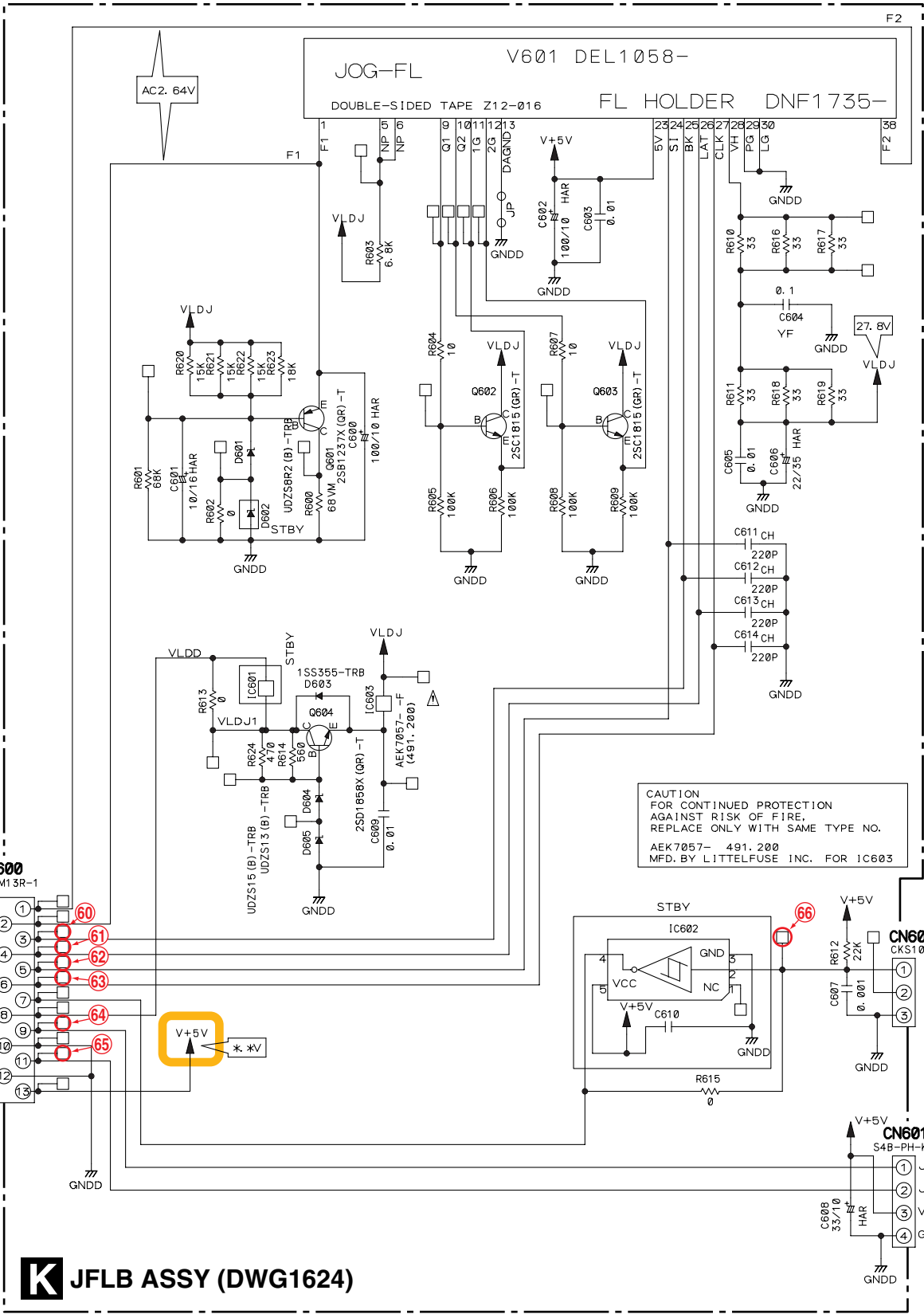

CAUTION
FOR CONTINUED PROTECTION
AGAINST RISK OF FIRE,
REPLACE ONLY WITH SAME TYPE NO.
AEK7057- 491.200
MFD. BY LITTELFUSE INC. FOR IC603

K JFLB ASSY (DWG1624)

Notes		
RESISTORS	NO MARK	:RS1/16S***J
	F	:RS1/16S***FJ
	VM	:RD1/2VM***J
CAPACITOR	NO MARK	:CKSRVF μF
	YF	:CKSRVF μF
	CH	:CCSRCH F
	HAR	:CEHAR μF
□ STBY is STANBY.		

3.11 WAVEFORMS

Note: The numbers for the waveform photos (circled) are identical to those for the schematic diagrams, PCB diagrams, and troubleshooting flowcharts.

A MAIN ASSY

CD player

RF eye pattern waveform (RFO)

- ① CH1 : RFO
V: 500 mV/div. H: 200 nsec/div.

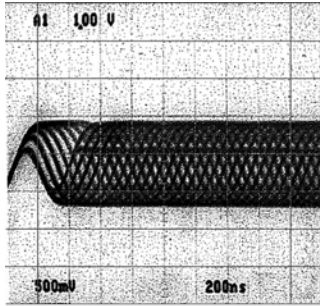

CD player

Load in (2/2)

- ③ CH1 : LPS1
V: 5.0 V/div. H: 100 msec/div.
- ④ CH2 : LPS2
V: 5.0 V/div. H: 100 msec/div.
- ⑥ CH3 : LO+
V: 5.0 V/div. H: 100 msec/div.
- ⑦ CH4 : LO-
V: 5.0 V/div. H: 100 msec/div.

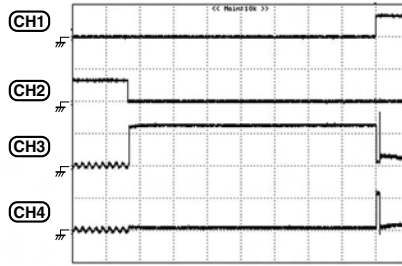

CD player

Focus in (1/2)

- ⑧ CH1 : FE
V: 0.5 V/div. H: 2 msec/div.

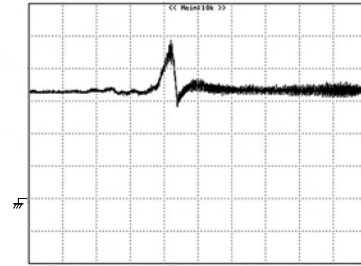

CD player

RF eye pattern waveform (AGCRF)

- ② CH1 : AGCRF
V: 500 mV/div. H: 200 nsec/div.

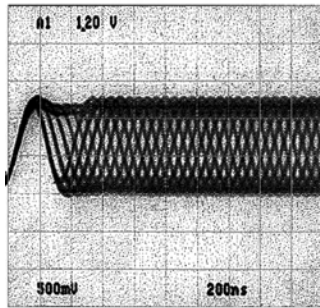

CD player

Load out (1/2)

- ③ CH1 : LPS1
V: 2.0 V/div. H: 500 msec/div.
- ④ CH2 : LPS2
V: 2.0 V/div. H: 500 msec/div.
- ⑤ CH3 : PWMLO
V: 2.0 V/div. H: 500 msec/div.

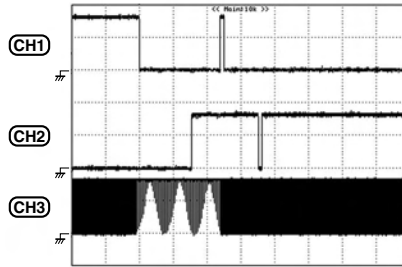

CD player

Focus in (2/2)

- ⑧ CH1 : FE
V: 0.5 V/div. H: 100 msec/div.
- ⑨ CH2 : FOO
V: 0.5 V/div. H: 100 msec/div.

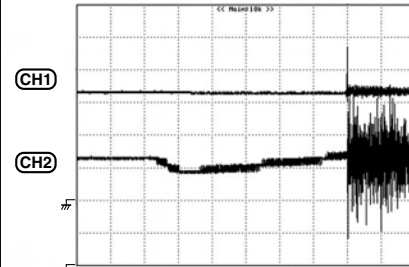

CD player

Load in (1/2)

- ③ CH1 : LPS1
V: 2.0 V/div. H: 100 msec/div.
- ④ CH2 : LPS2
V: 2.0 V/div. H: 100 msec/div.
- ⑤ CH3 : PWMLO
V: 2.0 V/div. H: 100 msec/div.

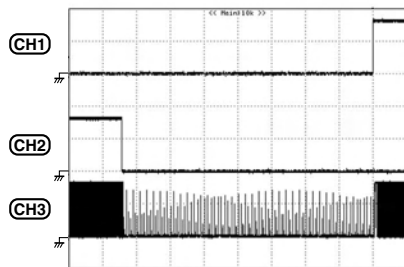

CD player

Load out (2/2)

- ③ CH1 : LPS1
V: 5.0 V/div. H: 500 msec/div.
- ④ CH2 : LPS2
V: 5.0 V/div. H: 500 msec/div.
- ⑥ CH3 : LO+
V: 5.0 V/div. H: 500 msec/div.
- ⑦ CH4 : LO-
V: 5.0 V/div. H: 500 msec/div.

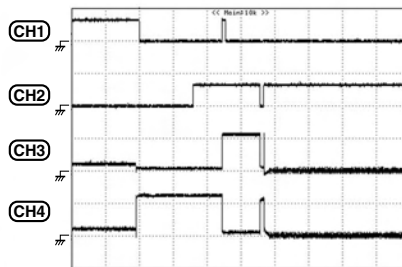

CD player

Start up

- ⑩ CH1 : INSIDE
V: 5.0 V/div. H: 200 msec/div.
- ⑧ CH2 : FE
V: 1.0 V/div. H: 200 msec/div.
- ⑪ CH3 : TE
V: 1.0 V/div. H: 200 msec/div.
- ⑫ CH4 : DMO
V: 2.0 V/div. H: 200 msec/div.

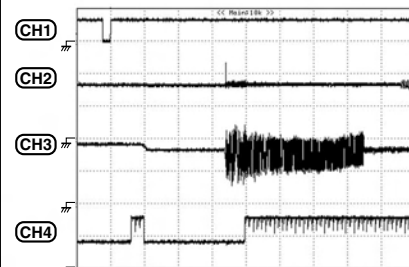

A MAIN ASSY

CD player

Stop

- ⑧ CH1 : FE
V: 1.0 V/div. H: 200 msec/div.
- ⑪ CH2 : TE
V: 1.0 V/div. H: 200 msec/div.
- ⑫ CH3 : DMO
V: 2.0 V/div. H: 200 msec/div.
- ⑬ CH4 : LDO
V: 2.0 V/div. H: 200 msec/div.

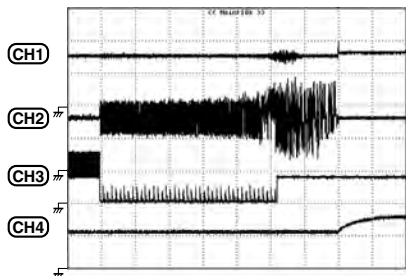

CD player

Pause

- ⑪ CH1 : TE
V: 1.0 V/div. H: 1 msec/div.
- ⑭ CH2 : TRO
V: 1.0 V/div. H: 1 msec/div.
- ① CH3 : RFO
V: 1.0 V/div. H: 1 msec/div.
- ⑰ CH4 : SBOK
V: 5.0 V/div. H: 1 msec/div.

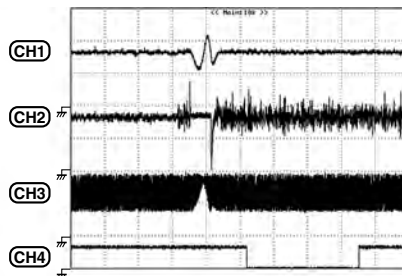

CD player

Track search (1/2)

- ⑪ CH1 : TE
V: 1.0 V/div. H: 50 msec/div.
- ⑭ CH2 : TRO
V: 1.0 V/div. H: 50 msec/div.
- ① CH3 : RFO
V: 1.0 V/div. H: 50 msec/div.
- ⑰ CH4 : SBOK
V: 5.0 V/div. H: 50 msec/div.

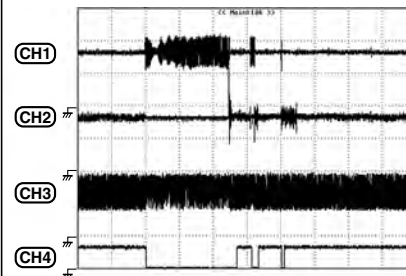

CD player

Auto adjust

- ⑧ CH1 : FE
V: 1.0 V/div. H: 500 msec/div.
- ⑨ CH2 : FOO
V: 1.0 V/div. H: 500 msec/div.
- ⑪ CH3 : TE
V: 1.0 V/div. H: 500 msec/div.
- ⑭ CH4 : TRO
V: 2.0 V/div. H: 500 msec/div.

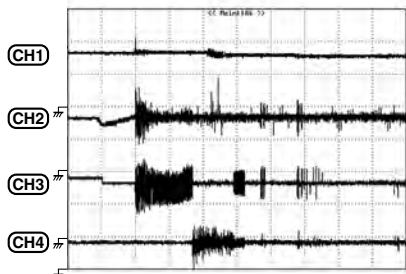

CD player

Scan (1/2)

- ⑪ CH1 : TE
V: 1.0 V/div. H: 2 msec/div.
- ⑭ CH2 : TRO
V: 1.0 V/div. H: 2 msec/div.
- ① CH3 : RFO
V: 1.0 V/div. H: 2 msec/div.
- ⑰ CH4 : SBOK
V: 5.0 V/div. H: 2 msec/div.

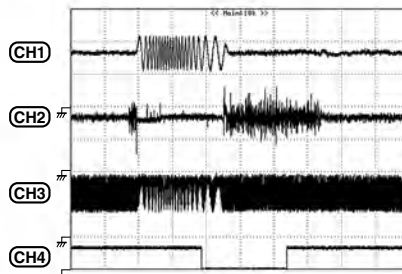

CD player

Track search (2/2)

- ⑧ CH1 : FE
V: 1.0 V/div. H: 50 msec/div.
- ⑪ CH2 : TE
V: 1.0 V/div. H: 50 msec/div.
- ⑮ CH3 : SL1IN
V: 1.0 V/div. H: 50 msec/div.
- ⑯ CH4 : SL2IN
V: 1.0 V/div. H: 50 msec/div.

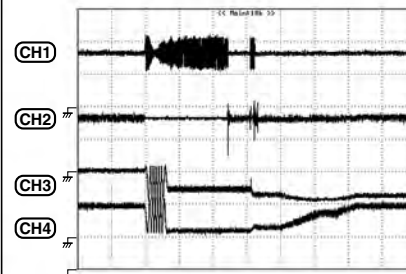

CD player

Play

- ⑧ CH1 : FE
V: 1.0 V/div. H: 500 msec/div.
- ⑪ CH2 : TE
V: 1.0 V/div. H: 500 msec/div.
- ⑮ CH3 : SL1IN
V: 1.0 V/div. H: 500 msec/div.
- ⑯ CH4 : SL2IN
V: 1.0 V/div. H: 500 msec/div.

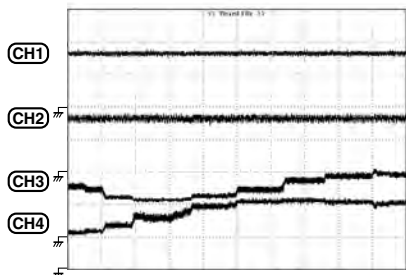

CD player

Scan (2/2)

- ⑧ CH1 : FE
V: 1.0 V/div. H: 50 msec/div.
- ⑪ CH2 : TE
V: 1.0 V/div. H: 50 msec/div.
- ⑮ CH3 : SL1IN
V: 1.0 V/div. H: 50 msec/div.
- ⑯ CH4 : SL2IN
V: 1.0 V/div. H: 50 msec/div.

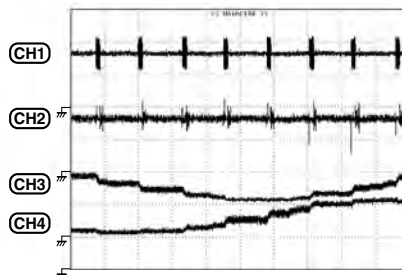

Reset system in the core block

- ⑱ CH1 : RST from Reset IC to CPU
V: 5.0 V/div. H: 200 msec/div.
- ⑲ CH2 : PRGM from CPU to FPGA through IC312
V: 5.0 V/div. H: 200 msec/div.
- ⑳ CH3 : SRVRST from CPU to IC101
V: 5.0 V/div. H: 200 msec/div.
- ㉑ CH4 : DSPRST from CPU to IC701
V: 5.0 V/div. H: 200 msec/div.

Conditions: At the time of power on,
without a disc loaded

a - b : 370 msec
a - c : 636 msec
a - d : 1 182 msec
e - a : 70 msec

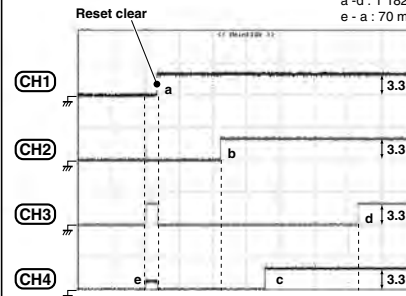

A

A MAIN ASSY

MPU
Delay time of Reset IC (IC304)

- 22 CH1 : V+3D
V: 2.0 V/div. H: 10 msec/div.
- 18 CH2 : RST from Reset IC to CPU
V: 2.0 V/div. H: 10 msec/div.

Conditions: At the time of power on, without a disc loaded
Remark: Set value for reset delay time: 70 msec

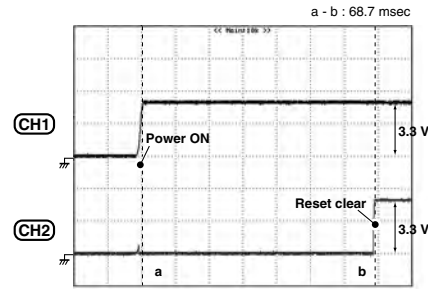

FPGA
Configuration (2/3)

- 24 CH2 : XINIT to CPU
V: 5.0 V/div. H: 100 msec/div.
- 26 CH4 : DATA from CPU
V: 5.0 V/div. H: 100 msec/div.
- 27 CH5 : DONE to CPU
V: 5.0 V/div. H: 100 msec/div.
- 30 CH8 : XFRST from CPU
V: 5.0 V/div. H: 100 msec/div.

Conditions: At the time of power on, without a disc loaded

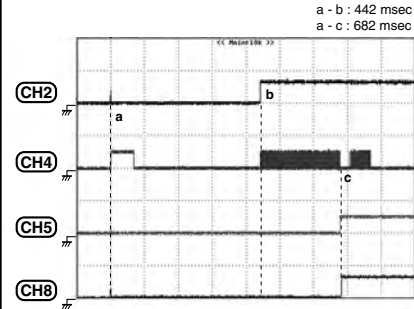

Audio DSP
Configuration (2/2)

- 29 CH1 : DSP16M from FPGA
V: 5.0 V/div. H: 200 msec/div.
- 26 CH5 : DATA from CPU
V: 5.0 V/div. H: 200 msec/div.
- 34 CH6 : DSPDREQ to FPGA & CPU
V: 5.0 V/div. H: 200 msec/div.
- 35 CH7 : DAC11M to IC702
V: 5.0 V/div. H: 200 msec/div.

Conditions: At the time of power on, without a disc loaded

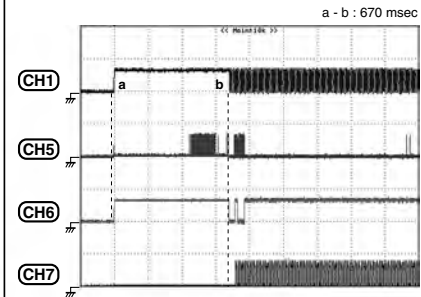

B

MPU
Association between the 16.93 MHz clock signal and resetting of the MPU

- 22 CH1 : V+3D
V: 5.0 V/div. H: 10 msec/div.
- 71 CH2 : CPU16M from IC310 to CPU
V: 5.0 V/div. H: 10 msec/div.
- 18 CH3 : RST from Reset IC to CPU
V: 5.0 V/div. H: 10 msec/div.

Conditions: At the time of power on, without a disc loaded

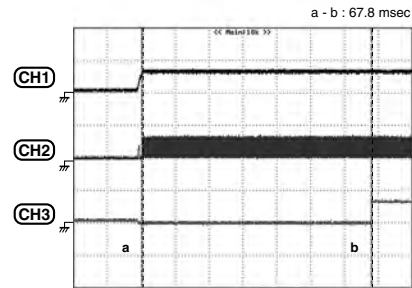

FPGA
Configuration (3/3)

- 27 CH5 : DONE to CPU
V: 5.0 V/div. H: 100 msec/div.
- 28 CH6 : SRV16M to IC101
V: 5.0 V/div. H: 100 msec/div.
- 29 CH7 : DSP16M to IC701
V: 5.0 V/div. H: 100 msec/div.
- 30 CH8 : XFRST from CPU
V: 5.0 V/div. H: 100 msec/div.

Conditions: At the time of power on, without a disc loaded

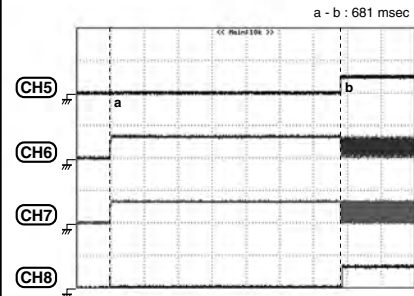

Servo DSP
Configuration (1/2)

- 28 CH1 : SRV16M from FPGA
V: 5.0 V/div. H: 200 msec/div.
- 20 CH2 : SRVRST from CPU
V: 5.0 V/div. H: 200 msec/div.
- 36 CH3 : SRVBUS0 CPU - SRV
V: 5.0 V/div. H: 200 msec/div.
- 37 CH4 : DRVMUTE1 from CPU to IC102
V: 5.0 V/div. H: 200 msec/div.

Conditions: At the time of power on, without a disc loaded

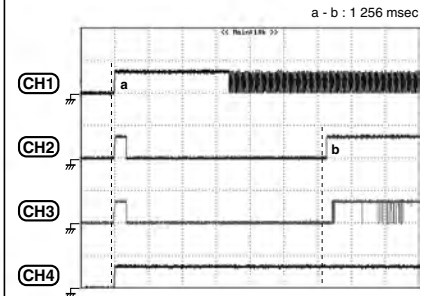

C

D

FPGA
Configuration (1/3)

- 23 CH1 : PROG_B (IC302 - pin 99) from CPU to FPGA
V: 5.0 V/div. H: 100 msec/div.
- 24 CH2 : XINIT to CPU
V: 5.0 V/div. H: 100 msec/div.
- 25 CH3 : CLK from CPU to FPGA
V: 5.0 V/div. H: 100 msec/div.
- 26 CH4 : DATA from CPU
V: 5.0 V/div. H: 100 msec/div.

Conditions: At the time of power on, without a disc loaded
a - b : 69 msec
a - c : 442 msec
b - c : 373 msec

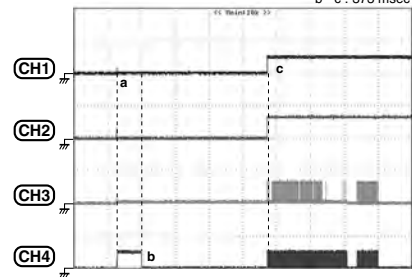

Audio DSP
Configuration (1/2)

- 29 CH1 : DSP16M from FPGA
V: 5.0 V/div. H: 200 msec/div.
- 21 CH2 : DSPRST from CPU
V: 5.0 V/div. H: 200 msec/div.
- 31 CH3 : DSPSIN to CPU
V: 5.0 V/div. H: 200 msec/div.
- 32 CH4 : CLK from CPU
V: 5.0 V/div. H: 200 msec/div.

Conditions: At the time of power on, without a disc loaded

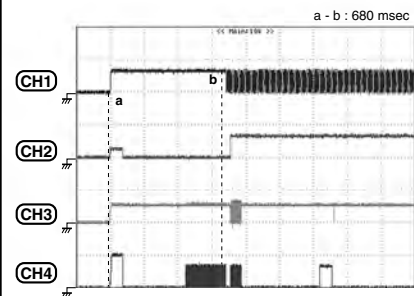

Servo DSP
Configuration (2/2)

- 28 CH1 : SRV16M from FPGA
V: 5.0 V/div. H: 200 msec/div.
- 20 CH2 : SRVRST from CPU
V: 5.0 V/div. H: 200 msec/div.
- 36 CH3 : SRVBUS0 CPU - SRV
V: 5.0 V/div. H: 200 msec/div.
- 38 CH5 : DRVMUTE2 from CPU to IC102
V: 5.0 V/div. H: 200 msec/div.

Conditions: At the time of power on, without a disc loaded

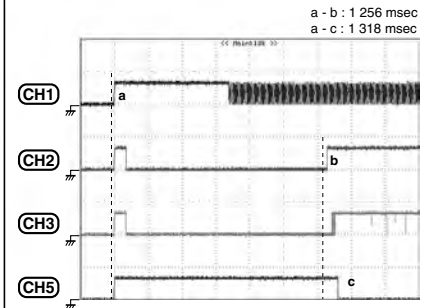

E

F

A MAIN ASSY

DAC

DAC reset

- (18) CH1 : RST from CPU Reset IC
V: 2.0 V/div. H: 1 sec/div.
- (35) CH2 : DAC11M from AUDIO DSP
V: 5.0 V/div. H: 1 sec/div.
- (39) CH3 : DACRST from CPU IC
V: 2.0 V/div. H: 1 sec/div.
- (40) CH4 : L4 (JACK Assy) Audio Signal Line
V: 20.0 V/div. H: 1 sec/div.

The MPU is started after a specific delay time.

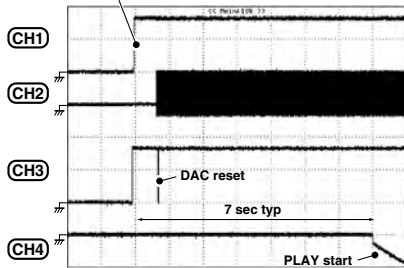

Audio mute

Association between zero-data detection and muting control (1/2)

- (41) CH1 : DACLRCK from DAC
V: 5.0 V/div. H: 1 sec/div.
- (42) CH2 : DACDATA from DAC
V: 5.0 V/div. H: 1 sec/div.
- (43) CH3 : DACBCK from DAC
V: 5.0 V/div. H: 1 sec/div.
- (44) CH4 : ZERO to CPU
V: 5.0 V/div. H: 1 sec/div.

Conditions: At the time of power on, with a disc loaded
a - b : 690 msec

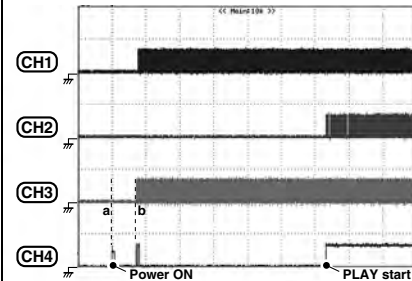

Audio mute

Conditions in which muting for zero-data detection is activated (pause, continuous search)

- (41) CH1 : DACLRCK from DAC
V: 5.0 V/div. H: 1 sec/div.
- (42) CH2 : DACDATA from DAC
V: 5.0 V/div. H: 1 sec/div.
- (43) CH3 : DACBCK from DAC
V: 5.0 V/div. H: 1 sec/div.
- (44) CH4 : ZERO to CPU
V: 5.0 V/div. H: 1 sec/div.

Conditions: During playback

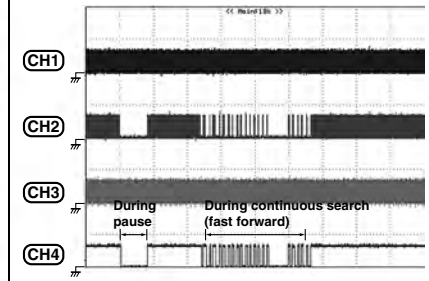

DAC

Initialization of DAC (downloading using the common 3-wire serial lines)

- (39) CH3 : DACRST from CPU IC
V: 5.0 V/div. H: 200 msec/div.
- (32) CH5 : CLK from CPU IC
V: 5.0 V/div. H: 200 msec/div.
- (26) CH6 : DATA from CPU IC
V: 5.0 V/div. H: 200 msec/div.
- (33) CH7 : DACCS from CPU IC
V: 5.0 V/div. H: 200 msec/div.

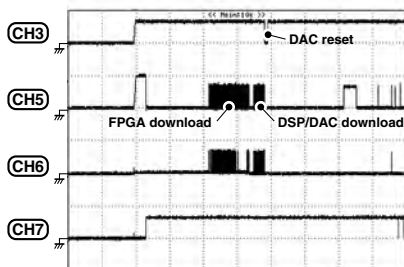

Audio mute

Association between zero-data detection and muting control (2/2)

- (44) CH4 : ZERO to CPU
V: 5.0 V/div. H: 1 sec/div.
- (45) CH5 : L ch to JACK Assy
V: 5.0 V/div. H: 1 sec/div.
- (46) CH6 : MUTE to JACK Assy
V: 5.0 V/div. H: 1 sec/div.
- (47) CH7 : L ch (JACK Assy)
V: 5.0 V/div. H: 1 sec/div.

Conditions: At the time of power on, with a disc loaded

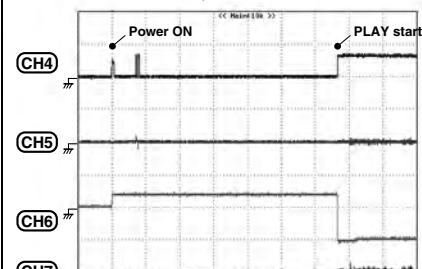

Audio mute

Conditions in which muting for zero-data detection is activated (Jog Touch, track search)

- (41) CH1 : DACLRCK from DAC
V: 5.0 V/div. H: 1 sec/div.
- (42) CH2 : DACDATA from DAC
V: 5.0 V/div. H: 1 sec/div.
- (43) CH3 : DACBCK from DAC
V: 5.0 V/div. H: 1 sec/div.
- (44) CH4 : ZERO to CPU
V: 5.0 V/div. H: 1 sec/div.

Conditions: During playback

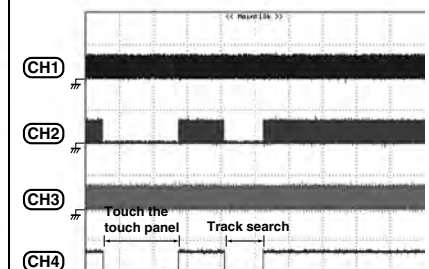

DAC

DAC controlled by the MPU (fixed-cycle polling using the common 3-wire serial lines)

- (39) CH3 : DACRST from CPU IC
V: 5.0 V/div. H: 5 µsec/div.
- (32) CH5 : CLK from CPU IC
V: 2.0 V/div. H: 5 µsec/div.
- (26) CH6 : DATA from CPU IC
V: 2.0 V/div. H: 5 µsec/div.
- (33) CH7 : DACCS from CPU IC
V: 2.0 V/div. H: 5 µsec/div.

Remarks:

- The MPU polls the audio DSP and DAC in a fixed cycle.
- The intervals of a cycle are 3 msec for playback of a CD-DA, and 10 msec for playback of a signal for MP3.

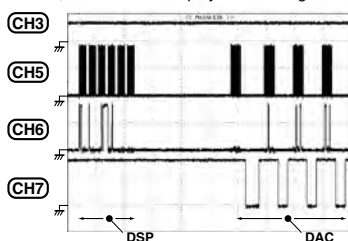

Audio mute

Conditions in which muting for zero-data detection is activated (Standby)

- (41) CH1 : DACLRCK from DAC
V: 5.0 V/div. H: 1 sec/div.
- (42) CH2 : DACDATA from DAC
V: 5.0 V/div. H: 1 sec/div.
- (43) CH3 : DACBCK from DAC
V: 5.0 V/div. H: 1 sec/div.
- (44) CH4 : ZERO to CPU
V: 5.0 V/div. H: 1 sec/div.

Conditions: At the time of power on, with a disc loaded

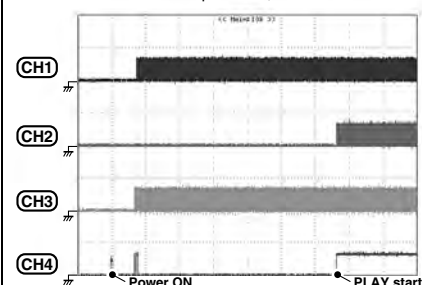

Audio mute

Conditions in which muting for zero-data detection is activated (between musical pieces)

- (41) CH1 : DACLRCK from DAC
V: 5.0 V/div. H: 1 sec/div.
- (42) CH2 : DACDATA from DAC
V: 5.0 V/div. H: 1 sec/div.
- (43) CH3 : DACBCK from DAC
V: 5.0 V/div. H: 1 sec/div.
- (44) CH4 : ZERO to CPU
V: 5.0 V/div. H: 1 sec/div.

Conditions: During playback

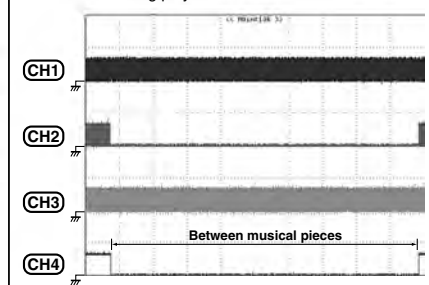

A MAIN ASSY

Digital output
Digital output (on PLAY)

⑦⑩ CH1 : DOUTJ to JACK Assy
V: 0.5 V/div. H: 2 μsec/div.

Conditions: During playback

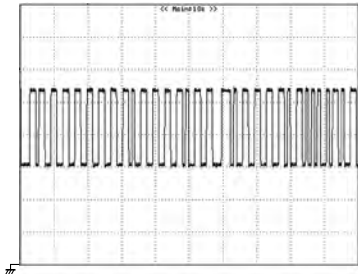

Digital output
Digital output (idle state)

⑦⑩ CH1 : DOUTJ to JACK Assy
V: 0.5 V/div. H: 2 μsec/div.

Conditions: No disc

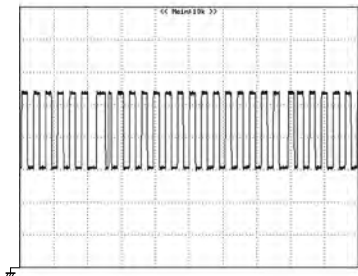

C SECB ASSY

Data copy (DATA IN/OUT terminal)
Detection of connection/disconnection of cables (connection)

⑤⑧ CH1 : RMIN Detect Line
V: 2.0 V/div. H: 50 msec/div.
⑤⑨ CH2 : JDATA Data Line
V: 2.0 V/div. H: 50 msec/div.

Conditions: At the time of cable connection

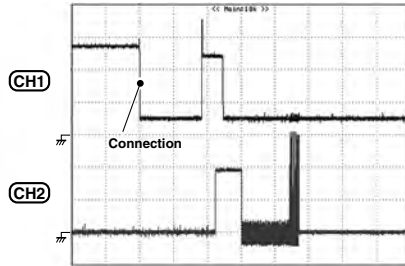

Data copy (DATA IN/OUT terminal)
Detection of connection/disconnection of cables (disconnection)

⑤⑧ CH1 : RMIN Detect Line
V: 2.0 V/div. H: 5 msec/div.
⑤⑨ CH2 : JDATA Data Line
V: 2.0 V/div. H: 5 msec/div.

Conditions: At the time of cable disconnection

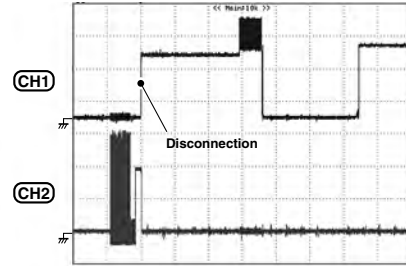

Data copy (DATA IN/OUT terminal)
Detection of connection/disconnection of cables (wireless)

⑤⑧ CH1 : RMIN Detect Line
V: 1.0 V/div. H: 1 msec/div.
⑤⑨ CH2 : JDATA Data Line
V: 1.0 V/div. H: 1 msec/div.

Conditions: Wireless, during idling

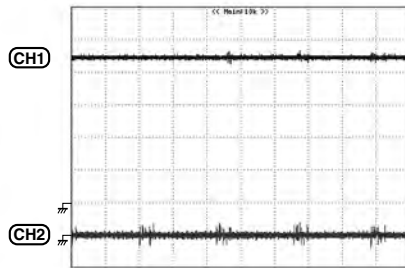

Data copy (DATA IN/OUT terminal)
Detection of connection/disconnection of cables (in a state in which the cables are connected)

⑤⑧ CH1 : RMIN Detect Line
V: 1.0 V/div. H: 1 msec/div.
⑤⑨ CH2 : JDATA Data Line
V: 1.0 V/div. H: 1 msec/div.

Conditions: In a state in which the cables are connected, during idling

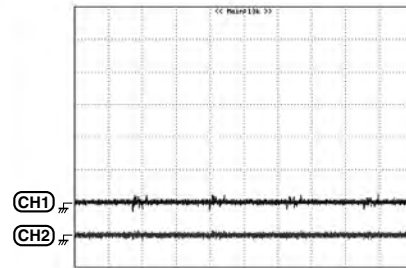

Data copy (DATA IN/OUT terminal)
Data copy

⑤⑧ CH1 : RMIN Detect Line
V: 2.0 V/div. H: 1 sec/div.
⑤⑨ CH2 : JDATA Data Line
V: 2.0 V/div. H: 1 sec/div.

Conditions: 10 POINTS × 1 disc

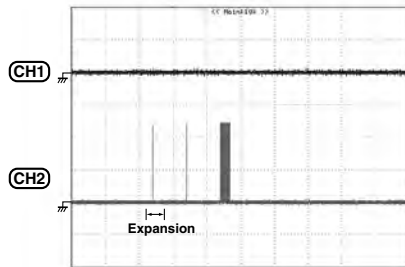

Data copy (DATA IN/OUT terminal)
Data copy (Expansion)

⑤⑧ CH1 : RMIN Detect Line
V: 2.0 V/div. H: 100 μsec/div.
⑤⑨ CH2 : JDATA Data Line
V: 2.0 V/div. H: 100 μsec/div.

Conditions: 10 POINTS × 1 disc

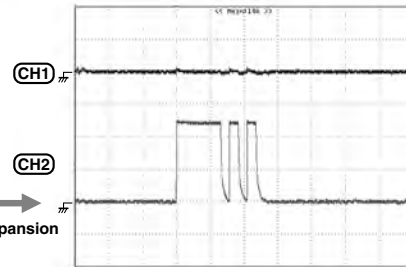

G DFLB ASSY

DISPLAY MPU

Delay time of Reset IC (IC502)

- (48) CH1 : V+5
V: 2.0 V/div. H: 10 msec/div.
(49) CH2 : XRST to DISP_CPU
V: 2.0 V/div. H: 10 msec/div.

Conditions: At the time of power on, without a disc loaded
Remark: Set value for reset delay time: 70 msec

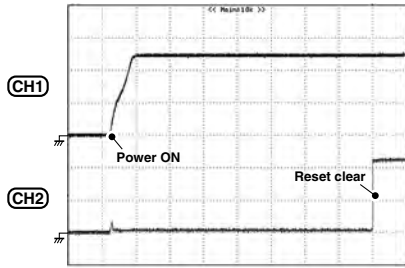

DISPLAY MPU

Association between 16 MHz clock signal and resetting of the DISPLAY MPU

- (48) CH1 : V+5
V: 5.0 V/div. H: 10 msec/div.
(72) CH2 : XOUT to DISP_CPU
V: 5.0 V/div. H: 10 msec/div.
(49) CH3 : XRST to DISP_CPU
V: 5.0 V/div. H: 10 msec/div.

Conditions: At the time of power on, without a disc loaded

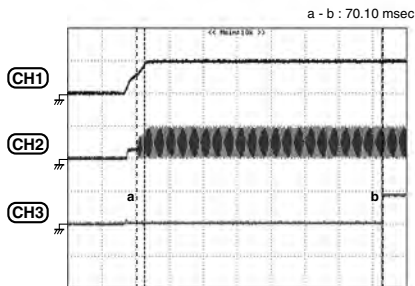

DISPLAY MPU

Communication between the FPGA and DISPLAY MPU (3-wire serial)

- (50) CH1 : TSCLK
V: 5.0 V/div. H: 200 msec/div.
(51) CH2 : TSCS
V: 5.0 V/div. H: 200 msec/div.
(52) CH3 : TSDI
V: 5.0 V/div. H: 200 msec/div.
(53) CH4 : TSDO
V: 5.0 V/div. H: 200 msec/div.

Conditions: At the time of power on, without a disc loaded
a - b : 169.5 msec
a - c : 679.7 msec
a - d : 1 186.4 msec

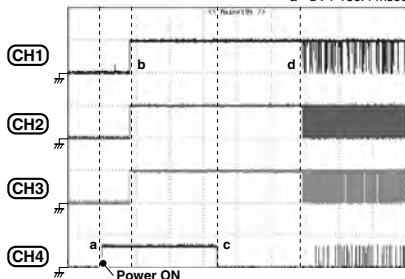

DATA-FL

Three-wire serial lines (at the time of power on)

- (54) CH1 : FLBK
V: 5.0 V/div. H: 100 msec/div.
(55) CH2 : FLLAT
V: 5.0 V/div. H: 100 msec/div.
(56) CH3 : FLSDO
V: 5.0 V/div. H: 100 msec/div.
(57) CH4 : FLSCCLK
V: 5.0 V/div. H: 100 msec/div.

Conditions: At the time of power on, without a disc loaded

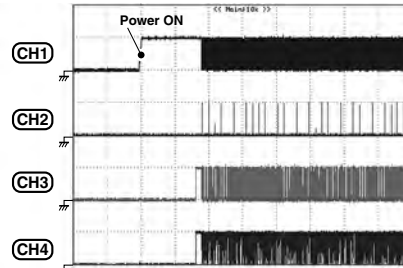

DATA-FL

Association between the built-in driver and the VLDD power

- (73) CH5 : VLDD
V: 20.0 V/div. H: 100 msec/div.
(48) CH6 : 5V
V: 5.0 V/div. H: 100 msec/div.
(54) CH1 : FLBK
V: 5.0 V/div. H: 100 msec/div.
(74) CH7 : FLAC1 and FLAC2
V: 5.0 V/div. H: 100 msec/div.

Conditions: At the time of power on, without a disc loaded

Remark: According to the FL specifications, the Vload power must be stably supplied before the built-in driver starts.

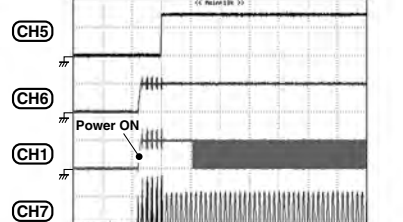

DATA-FL

Three-wire serial lines (during indication on the FL display)

- (54) CH1 : FLBK
V: 5.0 V/div. H: 1 msec/div.
(55) CH2 : FLLAT
V: 5.0 V/div. H: 1 msec/div.
(56) CH3 : FLSDO
V: 5.0 V/div. H: 1 msec/div.
(57) CH4 : FLSCCLK
V: 5.0 V/div. H: 1 msec/div.

Conditions: During playback

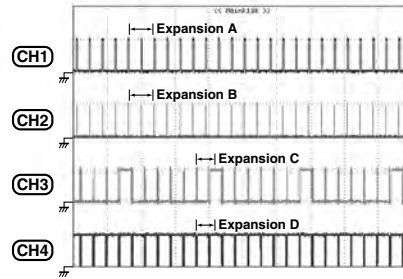

J SLDB ASSY

Tempo slider

Slide operation

- (68) CH1 : ADIN Detect DATA
V: 1.0 V/div. H: 500 msec/div.
(67) CH2 : ADCT Compare Level
V: 1.0 V/div. H: 500 msec/div.
(69) CH3 : GNDAD GND Level
V: 1.0 V/div. H: 500 msec/div.

Conditions: When the slider is moved from -100% to +100%

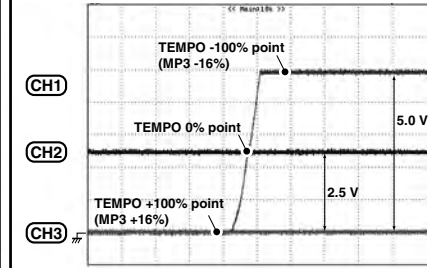

K JFLB ASSY

A

JOG-FL

Three-wire serial lines (At the time of power on)

- ⑥0 CH1 : JBK
V: 5.0 V/div. H: 100 msec/div.
- ⑥1 CH2 : JXSTB
V: 5.0 V/div. H: 100 msec/div.
- ⑥2 CH3 : JSDO
V: 5.0 V/div. H: 100 msec/div.
- ⑥3 CH4 : JSCLK
V: 5.0 V/div. H: 100 msec/div.

Conditions: At the time of power on, without a disc loaded

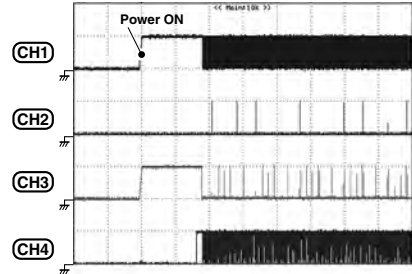

**During Jog Dial rotation (encoder process)
Encoder detection (during idling)**

- ⑥4 CH1 : JOG1 PHASE1 DATA
V: 2.0 V/div. H: 100 msec/div.
- ⑥5 CH2 : JOG2 PHASE2 DATA
V: 2.0 V/div. H: 100 msec/div.

Conditions: Idling

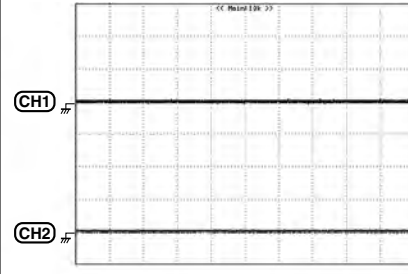

**During touch on the Jog plate
(detection of pressing force)**

- ⑥6 CH1 : TCH
V: 2.0 V/div. H: 10 msec/div.

Conditions: Without pressing force

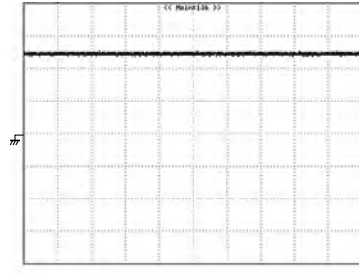

B

JOG-FL

Three-wire serial lines (during indication on the FL display, no disc)

- ⑥0 CH1 : JBK
V: 5.0 V/div. H: 2 msec/div.
- ⑥1 CH2 : JXSTB
V: 5.0 V/div. H: 2 msec/div.
- ⑥2 CH3 : JSDO
V: 5.0 V/div. H: 2 msec/div.
- ⑥3 CH4 : JSCLK
V: 5.0 V/div. H: 2 msec/div.

Conditions: No disc

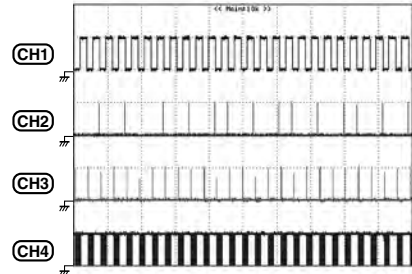

**During Jog Dial rotation (encoder process)
Encoder detection (during Jog Dial rotation)**

- ⑥4 CH1 : JOG1 PHASE1 DATA
V: 2.0 V/div. H: 100 msec/div.
- ⑥5 CH2 : JOG2 PHASE2 DATA
V: 2.0 V/div. H: 100 msec/div.

Conditions: During fast rotation

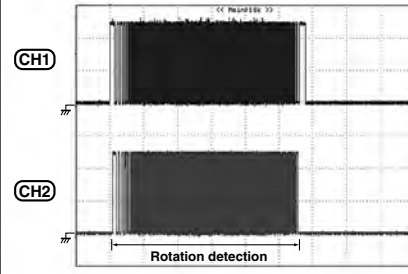

**During touch on the Jog plate
(detection of pressing force)**

- ⑥6 CH1 : TCH
V: 2.0 V/div. H: 10 msec/div.

Conditions: With pressing force

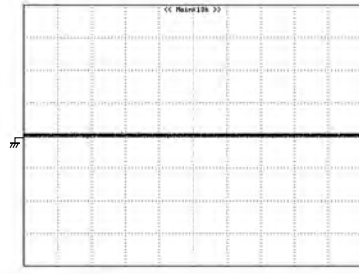

C

D

JOG-FL

Three-wire serial lines (during indication on the FL display, during playback)

- ⑥0 CH1 : JBK
V: 5.0 V/div. H: 2 msec/div.
- ⑥1 CH2 : JXSTB
V: 5.0 V/div. H: 2 msec/div.
- ⑥2 CH3 : JSDO
V: 5.0 V/div. H: 2 msec/div.
- ⑥3 CH4 : JSCLK
V: 5.0 V/div. H: 2 msec/div.

Conditions: With a disc loaded, during playback

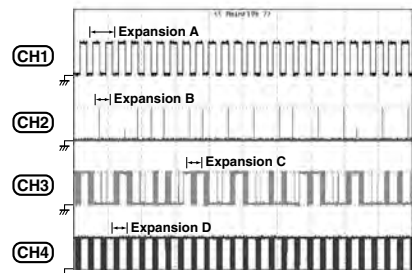

E

F

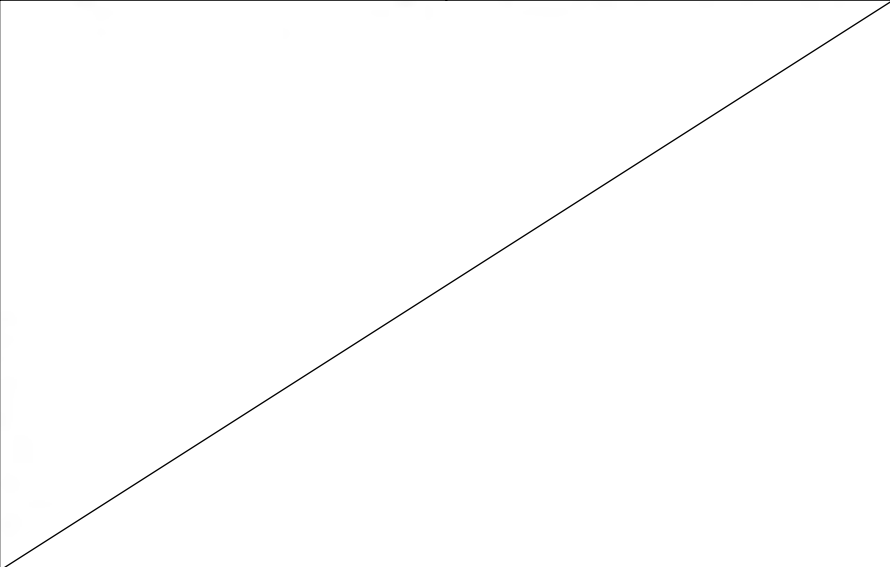

3.12 VOLTAGES

Note: The voltage measured using the HOZAN DT-113 Digital Tester is an approximation of DC voltage.

Note that the result of measurement of a waveform comprising many AC-current components will vary from tester to tester.

Conditions of measurement:

Play back Track 2 of the STD-905 Test Disc from Pioneer.

- For the IC mounted on the SECB Assy, measurement is performed with loads at the downstream stages lifted.
- The voltage at the MPU (IC301 on the MAIN Assy) is to be measured in Standby mode (not during CD playback), because the unit will freeze up (cannot play back a CD) if the core block is defective.
- As IC303 (SDRAM), IC101 (Servo DSP), IC312 (Logic), IC311 (Logic), IC103 (OP AMP), and IC310 (Logic) are mounted on surface B, measurement is performed with the FFC cable connecting the MAIN and JACK Assys disconnected.

A

MAIN ASSY

IC100 NJM2885DL1-33

Pin No.	Voltage (V)
1	6.0
2	0.00
3	3.3

IC103 NJU7013F

Pin No.	Voltage (V)
1	0.2
2	0.0
3	0.2
4	0.2
5	3.3

IC104 NJM2903M

Pin No.	Voltage (V)
1	3.1
2	1.7
3	1.8
4	0.0
5	1.7
6	1.7
7	1.5
8	3.3

IC105 TC7W04FU

Pin No.	Voltage (V)
1	0.0
2	1.7
3	0.0
4	0.0
5	3.3
6	1.6
7	3.3
8	3.3

IC106 TC7W08FU

Pin No.	Voltage (V)
1	3.3
2	0-3.2
3	0-3.2
4	0.0
5	0-3.2
6	0-3.2
7	0-3.2
8	3.3

IC101 TC94A15FG

Pin No.	Voltage (V)	Pin No.	Voltage (V)
1	0.0	51	1.6
2	2.9-3.3	52	0.0
3	0.0	53	2.4
4	3.3	54	1.6
5	0.0	55	1.5
6	0.0	56	1.8
7	0.0	57	1.7
8	0.0	58	1.6
9	0.0	59	3.3
10	0.0	60	1.6
11	3.3	61	1.6
12	0.0	62	1.6
13	3.3	63	1.6
14	1.6	64	2.0
15	1.6	65	0.0
16	1.6	66	0.0
17	1.6	67	0.7-1.0
18	1.4	68	0.0
19	1.6	69	0.0
20	0.6	70	3.3
21	1.6	71	0.0
22	1.6	72	0.0
23	1.6	73	1.6
24	0.0	74	1.5
25	1.7	75	3.3
26	1.6	76	0.0
27	1.6	77	1.6
28	1.6	78	3.3
29	3.3	79	0.0
30	1.5	80	1.6
31	1.6	81	0.0
32	1.5	82	0.0
33	1.6	83	0.0
34	0.0	84	3.2
35	1.6	85	3.2
36	1.3	86	3.2
37	1.3	87	3.2
38	3.3	88	3.2
39	0.0	89	2.8-3.0
40	3.3	90	3.3
41	2.4	91	3.3
42	0.2	92	1.8-2.4
43	0.0	93	3.3
44	1.8	94	0.0
45	1.7	95	3.3
46	1.7	96	0.0
47	1.7	97	1.7
48	1.8	98	1.7
49	1.8	99	1.7
50	-	100	0.0

IC102 M63018FP

Pin No.	Voltage (V)
1	1.0-2.5
2	1.0-2.5
3	7.1
4	7.1
5	0-7
6	0-7
7	0.0
8	7.1
9	0-7
10	0-7
11	0.0
12	0.5-1.2
13	0.5-1.2
14	0.5-1.2
15	7.1
16	2.5
17	2.5
18	2.5
19	2.5
20	2.5
21	2.5
22	7.1
23	1.7
24	1.6
25	1.7
26	1.7
27	1.7
28	1.7
29	0.0
30	3.1
31	3.1
32	7.1
33	0.0
34	3.1
35	3.1
36	1.1
37	1.1
38	3.3
39	7.1
40	1.7
41	3.3
42	1.1

IC300 DYW1753-B/J

Pin No.	Voltage (V)
1	2.2
2	2.1-2.4
3	0.9-1.2
4	1.7-2.0
5	1.7-1.9
6	1.9-2.2
7	2.0-2.2
8	2.1-2.4
9	0.0
10	0.0
11	2.5-2.8
12	3.3
13	0.0
14	0.0
15	3.3
16	0.5
17	1.2-1.5
18	2.1-2.4
19	2.1-2.4
20	1.8-2.2
21	1.9-2.2
22	1.9-2.2
23	0.9-1.1
24	2.1-2.4
25	1.9
26	3.3
27	0.0
28	3.3
29	0.0
30	3.3
31	0.5-0.8
32	0.5-0.9
33	0.5-0.8
34	0.5-0.8
35	0.5-0.8
36	0.4-0.7
37	3.3
38	0.7-0.8
39	0.6-0.8
40	0.6-0.8
41	0.8-1.0
42	0.5-0.7
43	0.4-0.6
44	0.6-0.7
45	0.5-0.7
46	0.0
47	3.3
48	1.3-1.5

IC301 SCF5249VM140

Pin No.	Voltage (V)	Pin No.	Voltage (V)	Pin No.	Voltage (V)
A1	3.3	F2	0.3	M13	3.2
A2	3.3	F3	3.2	M14	1.5
A3	2.3	F4	0.0	N1	0.7
A4	2.4	F11	0.0	N2	1.2
A5	2.4	F12	0.0	N3	3.0
A6	3.3	F13	3.3	N4	3.3
A7	0.0	F14	0.0	N5	0.0
A8	3.3	G1	0.5	N6	0.6
A9	3.3	G2	0.5	N7	0.4
A10	0.0	G3	0.8	N8	0.0
A11	2.7	G4	0.0	N9	0.0
A12	3.3	G11	3.3	N10	3.3
A13	0.0	G12	0.0	N11	1.7
A14	0.0	G13	0.0	N12	3.3
B1	2.3	G14	0.0	N13	2.5
B2	2.0	H1	0.4	N14	1.7
B3	2.3	H2	0.6	P1	3.0
B4	2.4	H3	0.0	P2	2.6
B5	0.9	H4	0.0	P3	0.0
B6	2.1	H11	1.8	P4	3.3
B7	3.3	H12	3.2	P5	3.3
B8	0.0	H13	3.3	P6	3.3
B9	3.3	H14	1.6	P7	0.6
B10	0.0	J1	0.7	P8	0.5
B11	3.3	J2	0.4	P9	0.0
B12	0.0	J3	3.2	P10	1.5
B13	3.2	J4	0.0	P11	0.0
B14	0.0	J11	0.0	P12	3.3
C1	2.4	J12	3.3	P13	3.3
C2	2.1	J13	0.0	P14	3.3
C3	0.0	J14	0.0		
C4	1.8	K1	0.5		
C11	3.3	K2	2.0		
C12	2.2	K3	0.0		
C13	0.0	K4	0.0		
C14	0.0	K5	0.0		
D1	1.2	K6	1.8		
D2	1.1	K7	0.5		
D3	0.3	K8	3.3		
D4	0.0	K9	0.0		
D5	0.0	K10	0.0		
D6	0.0	K11	0.0		
D7	3.3	K12	0.0		
D8	0.0	K13	0.0		
D9	0.0	K14	0.0		
D10	0.0	L1	0.9		
D11	0.0	L2	2.4		
D12	0.0	L3	3.3		
D13	0.0	L4	3.3		
D14	0.0	L5	3.3		
E1	3.3	L6	3.3		
E2	1.7	L7	4.9		
E3	0.0	L8	0.0		
E4	2.7	L9	4.4		
E5	3.3	L10	1.8		
E6	0.0	L11	0.0		
E7	3.3	L12	3.2		
E8	3.3	L13	1.6		
E9	1.8	L14	3.3		
E10	0.0	M1	2.3		
E11	0.0	M2	0.6		
E12	0.0	M3	0.0		
E13	0.0	M4	0.0		
E14	0.0	M11	3.3		
F1	0.0	M12	0.0		

IC302 XC3S50-4VQG100C

Pin No.	Voltage (V)	Pin No.	Voltage (V)
1	0-1.8	51	2.5
2	1.6	52	0.0
3	0.0	53	2.0
4	3.2	54	1.9-2.2
5	0.0	55	0.0
6	3.3	56	0.0
7	2.5	57	3.3
8	0.0	58	2.5
9	1-4.5	59	0.9
10	0.0	60	2.4
11	1-4.5	61	2.8
12	1.6	62	0.0
13	1.6-1.8	63	3.3
14	1.7	64	3.3
15	1.7	65	0.0
16	1.8	66	0.0
17	1.9	67	1.6
18	1.2	68	1.7
19	3.3	69	1.2
20	0.0	70	3.3
21	0.5-0.7	71	1.6
22	0.5-0.7	72	3.3
23	0.5-0.7	73	0.0
24	2.5	74	3.2
25	2.5	75	0.2
26	2.5	76	2.5
27	0.7-0.9	77	2.5
28	0.7-0.9	78	2.5
29	0.0	79	0.0
30	0.5-0.7	80	2.7
31	3.3	81	0.0
32	0.4-0.7	82	0.0
33	2.5	83	3.3
34	0.6-0.9	84	2.5
35	0.4-0.8	85	0.0
36	0.5-0.7	86	0.0
37	1.6	87	0.0
38	0.5-0.7	88	0.0
39	1.7	89	0.0
40	0.0	90	0.0
41	0.0	91	0.0
42	3.3	92	0.0
43	0.5-0.7	93	1.2
44	0.8-1.0	94	3.3
45	1.2	95	0.0
46	3.3	96	0.0
47	0.6-0.8	97	0.0
48	0.0	98	0.0
49	0.5-0.8	99	2.5
50	0.5-0.8	100	2.5

IC303 K4S641632K-UC75

Pin No.	Voltage (V)
1	3.3
2	0.0
3	3.3
4	0.5-0.7
5	0.6-0.9
6	0.0
7	0.6-0.8
8	0.7-0.8
9	3.3
10	0.6-0.9
11	0.7-0.9
12	0.0
13	0.6-0.8
14	3.3
15	0.0
16	3.0
17	2.6
18	2.8
19	1.2
20	0.9-1.1
21	0.4-0.8
22	0.6
23	0.0
24	2.3
25	0.9-1.1
26	1.7-1.9
27	3.3
28	0.0
29	1.7-1.9
30	1.9-2.2
31	2.0-2.2
32	2.1-2.4
33	1.3-1.6
34	1.2-1.5
35	0.8-1.1
36	0.0
37	3.3
38	1.7
39	0.1
40	0.0
41	0.0
42	0.5-0.7
43	3.3
44	0.5-0.8
45	0.5-0.8
46	0.0
47	3.3
48	0.4-0.7
49	3.3
50	0.8-1.0
51	0.5-0.7
52	0.0
53	0.5-0.8
54	0.0

IC304 BU4230G

Pin No.	Voltage (V)
1	3.3
2	3.3
3	0.0
4	0.0
5	1.7

IC305 MM1561JF

Pin No.	Voltage (V)
1	1.8
2	0.0
3	0.0
4	0.5
5	3.3
6	0.0
7	3.3

IC306 MM1562FF

Pin No.	Voltage (V)
1	2.5
2	0.0
3	0.0
4	1.2
5	3.3
6	0.0
7	3.3

IC307 BD00KA5WFP

Pin No.	Voltage (V)
1	3.3
2	3.3
3	0.0
4	1.2
5	0.8

IC308 TC74VHC08FTS1

Pin No.	Voltage (V)
1	3.3
2	4.8
3	3.2
4	3.3
5	4.3
6	2.9
7	0.0
8	0.0
9	3.3
10	0.0
11	2.7
12	3.3
13	4.0
14	3.3

IC309 TC7SET08FUS1

Pin No.	Voltage (V)
1	4.9
2	3.3
3	0.0
4	4.9
5	4.9

IC310 TC7WU04FU

Pin No.	Voltage (V)
1	1.6
2	1.6
3	1.6
4	0.0
5	1.6
6	1.6
7	1.6
8	3.3

IC311 TC7SH08FUS1

Pin No.	Voltage (V)
1	2.5
2	0.0
3	0.0
4	0.0
5	2.5

IC312 TC7SH08FUS1

Pin No.	Voltage (V)
1	2.5
2	3.3
3	0.0
4	2.5
5	2.5

IC702 PE8001A

Pin No.	Voltage (V)
1	1.6
2	0.0
3	1.6
4	0.0
5	1.6
6	0.0
7	0.0
8	5.0
9	5.0
10	0.0
11	2.5
12	0.0
13	2.5
14	0.0
15	5.0
16	2.5
17	0.0
18	2.5
19	0.0
20	5.0
21	3.3
22	5.0
23	0.0
24	0.0
25	0.0
26	0.0
27	0.0
28	3.3

IC703 BD00KA5WFP

Pin No.	Voltage (V)
1	3.3
2	3.3
3	0.0
4	1.3
5	0.8

IC704 NJM2880U1-05

Pin No.	Voltage (V)
1	8.0
2	0.0
3	1.3
4	5.0
5	8.0

IC701 DSPC56371AF180

Pin No.	Voltage (V)	Pin No.	Voltage (V)
1	0.0	41	3.3
2	0.0	42	0.0
3	3.3	43	0.0
4	0.0	44	1.3
5	0.0	45	1.7-1.8
6	0.0	46	1.2
7	0.8	47	3.3
8	1.3	48	0.6
9	0.0	49	3.3
10	0.0	50	0.6
11	0.0	51	3.3
12	0.0	52	1.3
13	0.0	53	0.0
14	0.0	54	0.0
15	0.0	55	0.0
16	0.0	56	0.0
17	3.3	57	0.0
18	0.0	58	0.0
19	0.0	59	1.0
20	0.0	60	3.2
21	0.0	61	1.6
22	0.0	62	0.0
23	3.3	63	1.7
24	0.0	64	3.3
25	3.3	65	0.0
26	0.0	66	0.0
27	0.0	67	0.0
28	0.0	68	0.0
29	1.3	69	1.6
30	1.1	70	1.6
31	3.0	71	1.3
32	0.0	72	0.0
33	3.0	73	1.6
34	0.0	74	0.0
35	2.6	75	3.3
36	0.0	76	1.7
37	3.3	77	1.6
38	0.0	78	1.6
39	3.3	79	1.6
40	0.0	80	0.0

C

A

SECB ASSY

IC050 BA00BC0WCP-V5

Pin No.	Voltage (V)
1	12.3
2	12.3
3	0.0
4	8.0
5	1.3

IC051 NJM2374AM

Pin No.	Voltage (V)
1	8.0
2	-2.7
3	-6.1
4	-7.0
5	-5.7
6	8.1
7	8.0
8	8.0

B

IC052 TC7S04FU

Pin No.	Voltage (V)
1	0.0
2	0.0
3	0.0
4	2.7
5	5.0

C

IC057 BA50BC0WFP

Pin No.	Voltage (V)
1	8.0
2	8.0
3	0.0
4	5.0
5	0.0

REGB ASSY

IC091 BA00BC0WCP-V5

Pin No.	Voltage (V)
1	6.0
2	6.0
3	0.0
4	3.3
5	1.3

D

IC092 BA00BC0WCP-V5

Pin No.	Voltage (V)
1	11.2
2	11.2
3	0.0
4	7.2
5	1.3

E

F

G**DFLB ASSY**

IC501 PEG237B

Pin No.	Voltage (V)	Pin No.	Voltage (V)
1	0.0	51	0.0
2	0.0	52	4.9
3	0.0	53	4.9
4	0.0	54	4.9
5	0.0	55	4.9
6	4.9	56	4.9
7	0.0	57	0.0
8	0.0	58	4.9
9	0.0	59	0.0
10	0.0	60	0.0
11	0.0	61	0.0
12	4.5	62	4.9
13	2.6	63	0.0
14	0.0	64	0.0
15	2.3	65	0.0
16	5.0	66	0.0
17	5.0	67	0.0
18	5.0	68	0.0
19	5.0	69	0.0
20	5.0	70	0.0
21	5.0	71	0.0
22	5.0	72	0.0
23	5.0	73	0.0
24	4.9	74	0.0
25	4.9	75	0.0
26	0.0	76	0.0
27	4.9	77	0.0
28	3.9	78	0.0
29	0.0	79	4.9
30	1.4-1.8	80	4.9
31	0.8	81	4.9
32	4.9	82	4.9
33	4.5	83	4.9
34	4.9	84	4.9
35	4.3	85	4.9
36	0.1	86	4.9
37	4.8	87	4.9
38	4.0	88	4.9
39	4.9	89	2.5
40	0.0	90	2.5
41	0.0	91	4.9
42	0.0	92	4.9
43	0.6	93	4.9
44	0.0	94	4.9
45	2.8	95	4.9
46	4.9	96	0.0
47	0.0	97	0.0
48	4.9	98	4.9
49	4.9	99	4.9
50	0.0	100	4.9

IC502 BU4242G

Pin No.	Voltage (V)
1	4.5
2	4.9
3	0.0
4	0.0
5	2.6

IC503 TC7SET08FUS1

Pin No.	Voltage (V)
1	4.9
2	0.0
3	0.0
4	0.1
5	4.9

I**JACK ASSY**







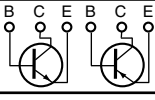

IC801 NJM4558DX

Pin No.	Voltage (V)
1	0.0
2	0.0
3	0.0
4	-6.0
5	0.0
6	0.0
7	0.0
8	8.0

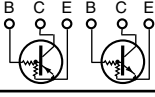
4. PCB CONNECTION DIAGRAM

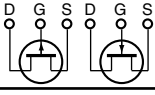
NOTE FOR PCB DIAGRAMS :

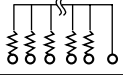
1. Part numbers in PCB diagrams match those in the schematic diagrams.
2. A comparison between the main parts of PCB and schematic diagrams is shown below.

Symbol In PCB Diagrams	Symbol In Schematic Diagrams	Part Name
		Transistor
		Transistor with resistor
		Field effect transistor
		Resistor array
		3-terminal regulator

3. The parts mounted on this PCB include all necessary parts for several destinations.
For further information for respective destinations, be sure to check with the schematic diagram.
4. View point of PCB diagrams.

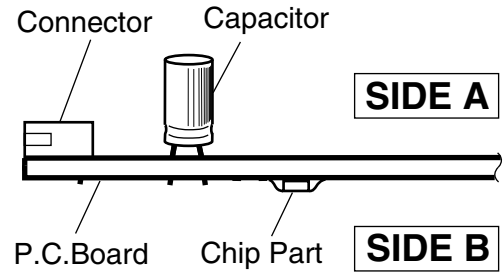

4.1 MAIN ASSY

SIDE A

A MAIN ASSY

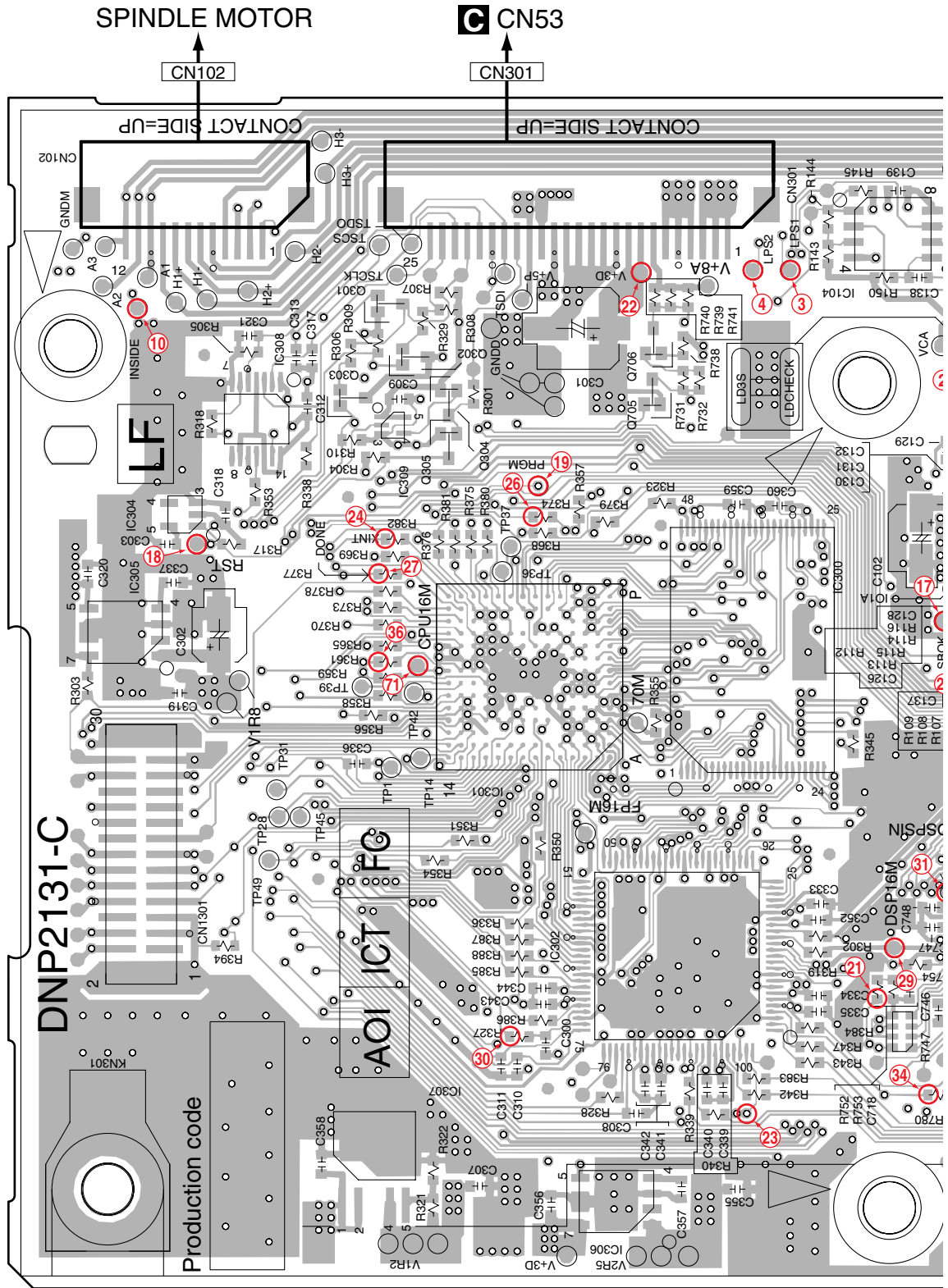

IC304	IC308	Q301	Q305	Q302	IC302	Q706	IC300
IC305	IC308	Q303	Q305	Q304	IC302	Q705	IC104
IC304		Q301	IC309	Q302		Q706	IC300
IC305		Q303	IC309	Q304		Q705	IC104
				IC307	IC301	IC306	
				IC307	IC301	IC306	

CDJ-800MK2

A

NOTE : The encircled numbers denote measuring point.

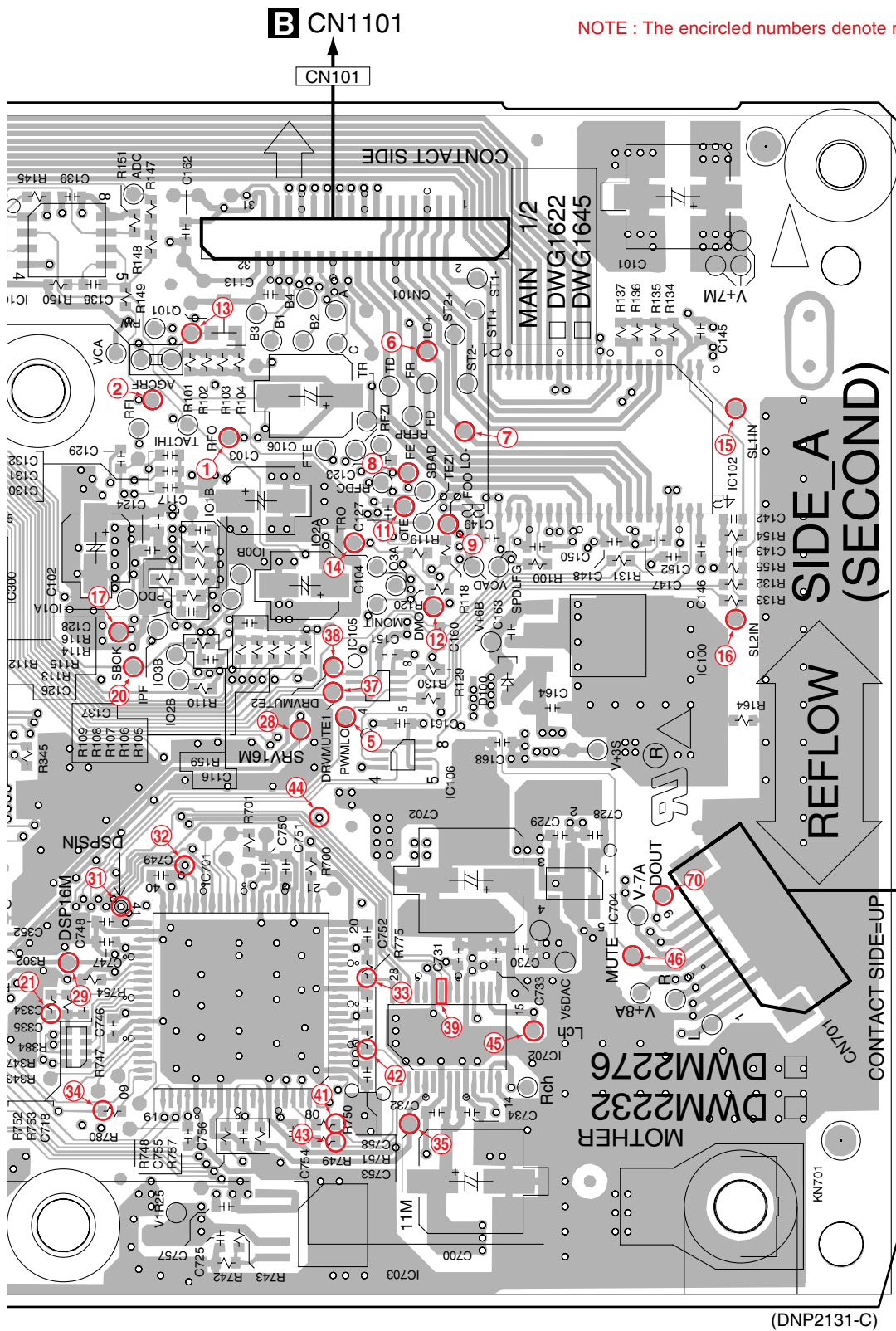

(DNP2131-C)

00	Q101	IC105	IC703	IC106	IC702	IC704	IC100
IC104	Q101	IC105	IC703	IC106	IC702	IC704	IC102
00	IC701						IC100
IC104	IC701						IC102

SIDE B

A MAIN ASSY

A

B

C

D

E

F

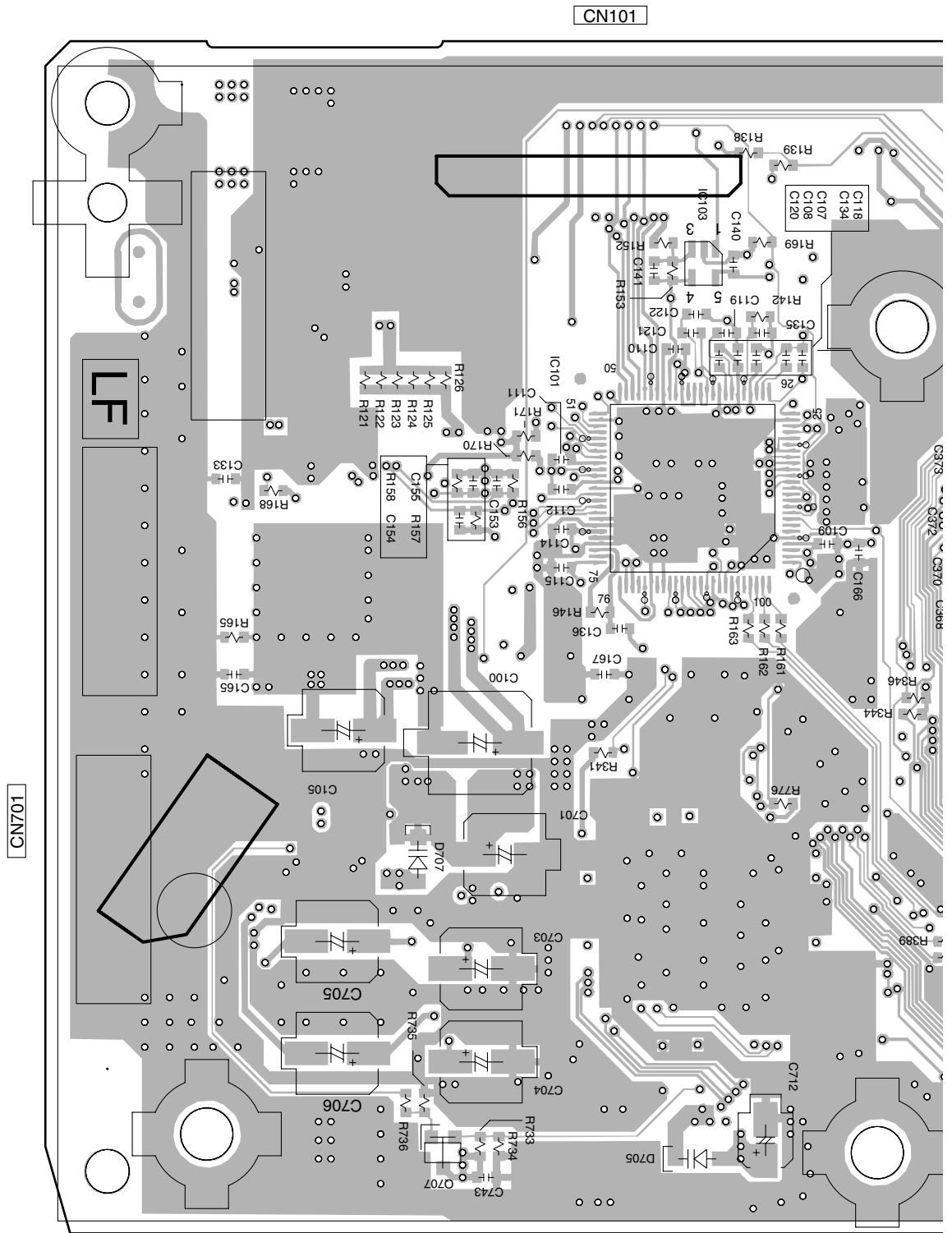

Q707	IC101	IC103
Q707	IC101	IC103

A

A
B
C
D
E
F

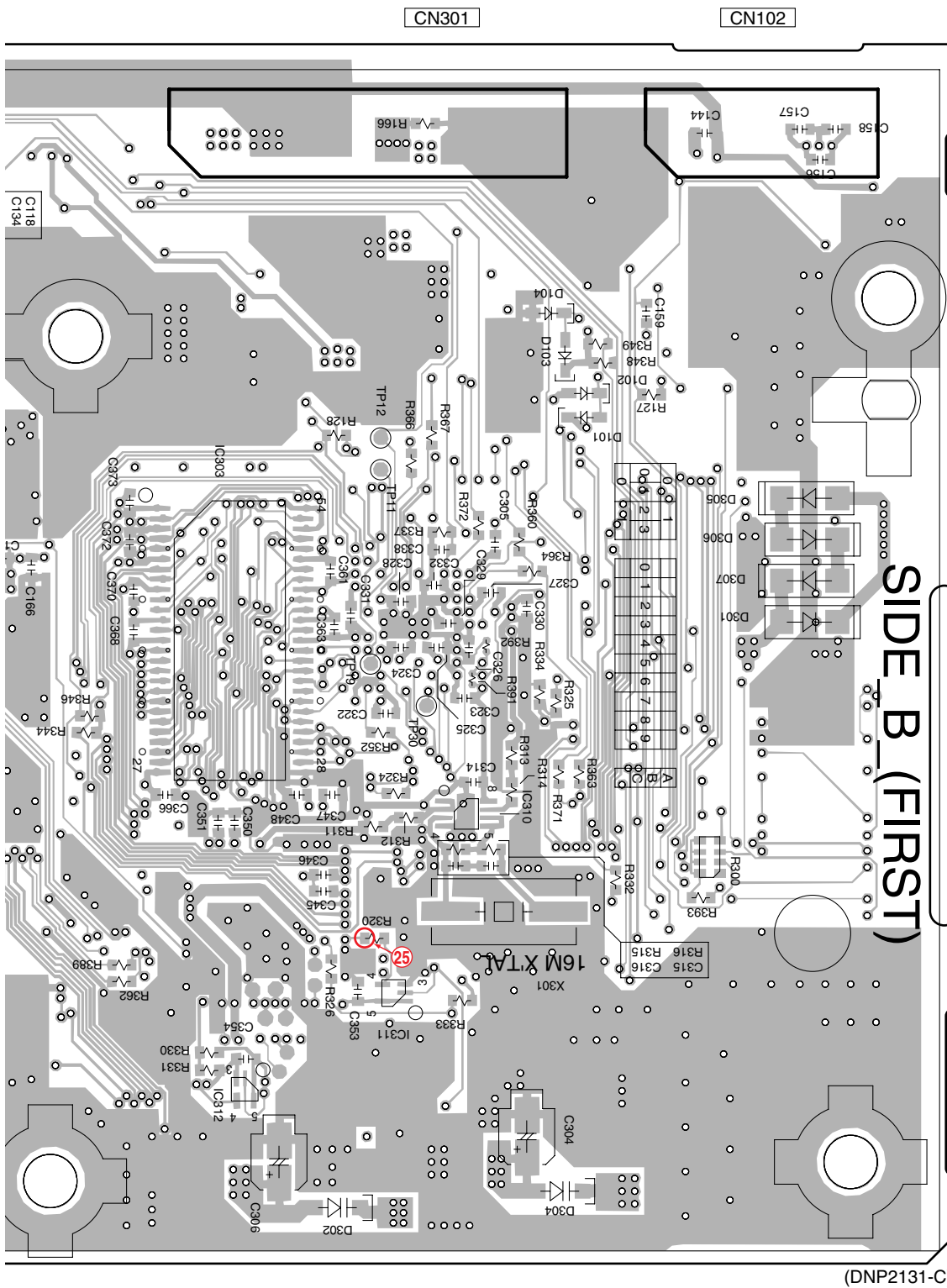

SIDE B (FIRST)

(DNP2131-C)

- IC303
- IC311
- IC310
- IC312
- IC311
- IC310
- IC303
- IC312

NOTE : The encircled numbers denote measuring point.

4.2 RLYB ASSY

SIDE A

SIDE A

B RLYB ASSY

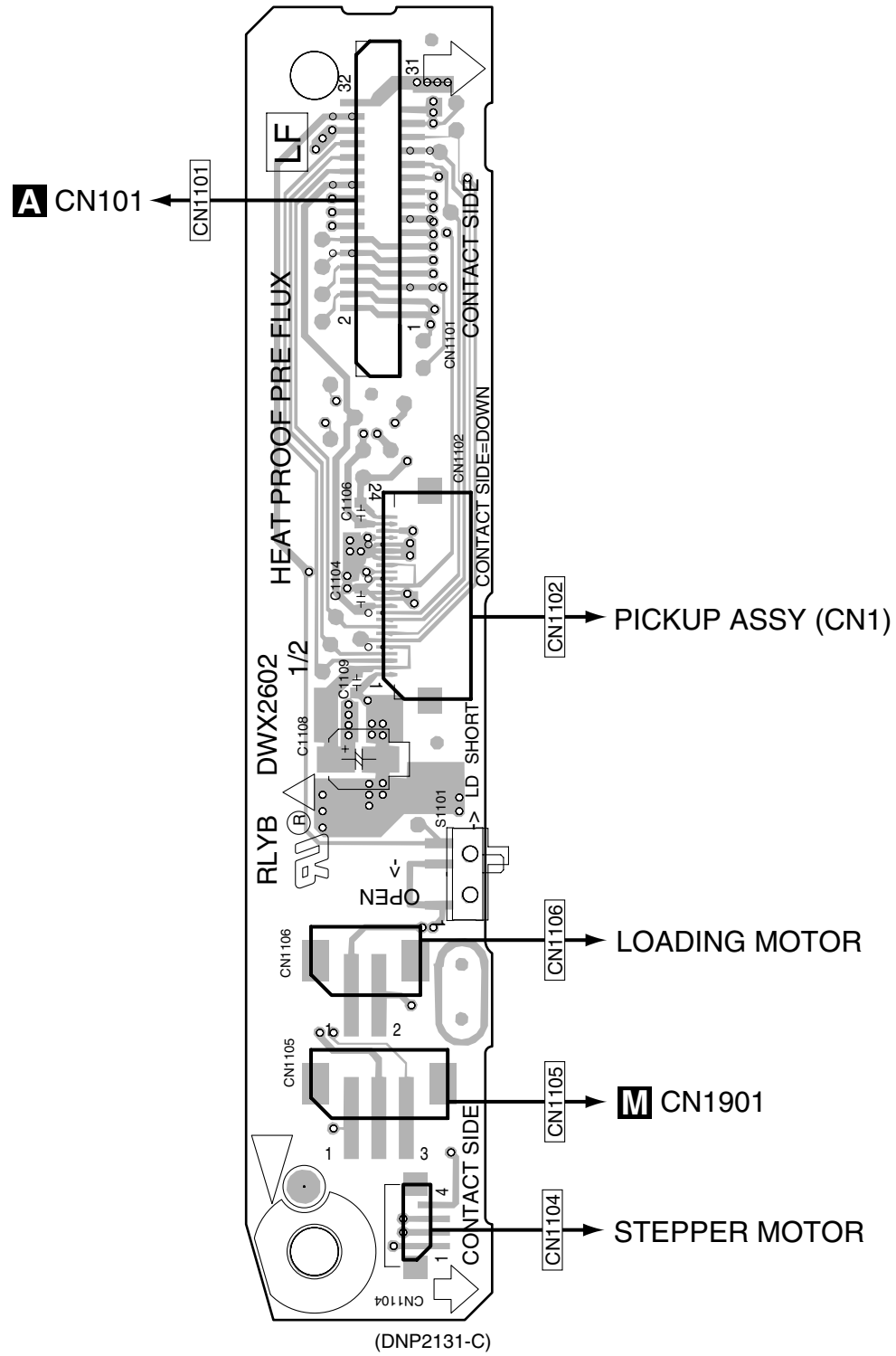

B

B

SIDE B

SIDE B

A

B RLYB ASSY

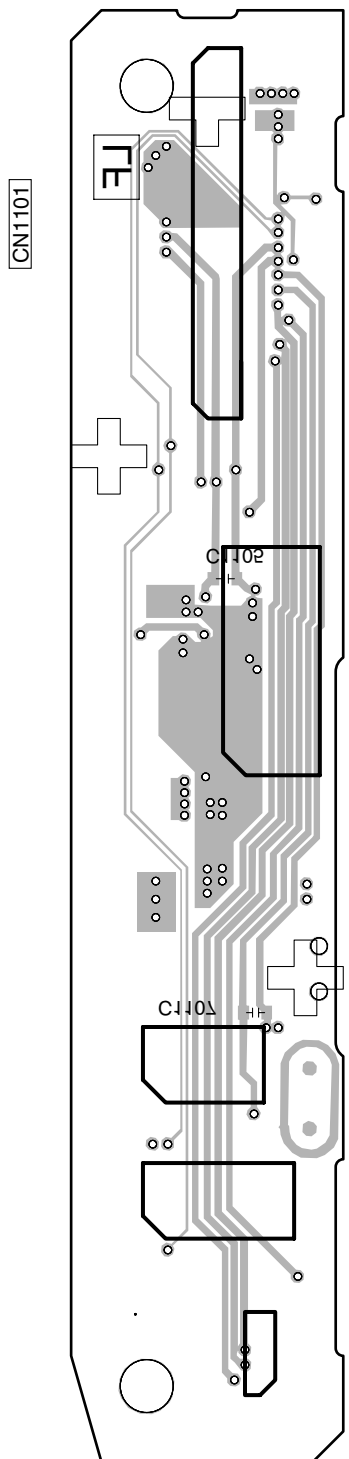

(DNP2131-C)

B

C

D

E

F

B

B

4.3 SECB ASSY

SIDE A

C SECB ASSY

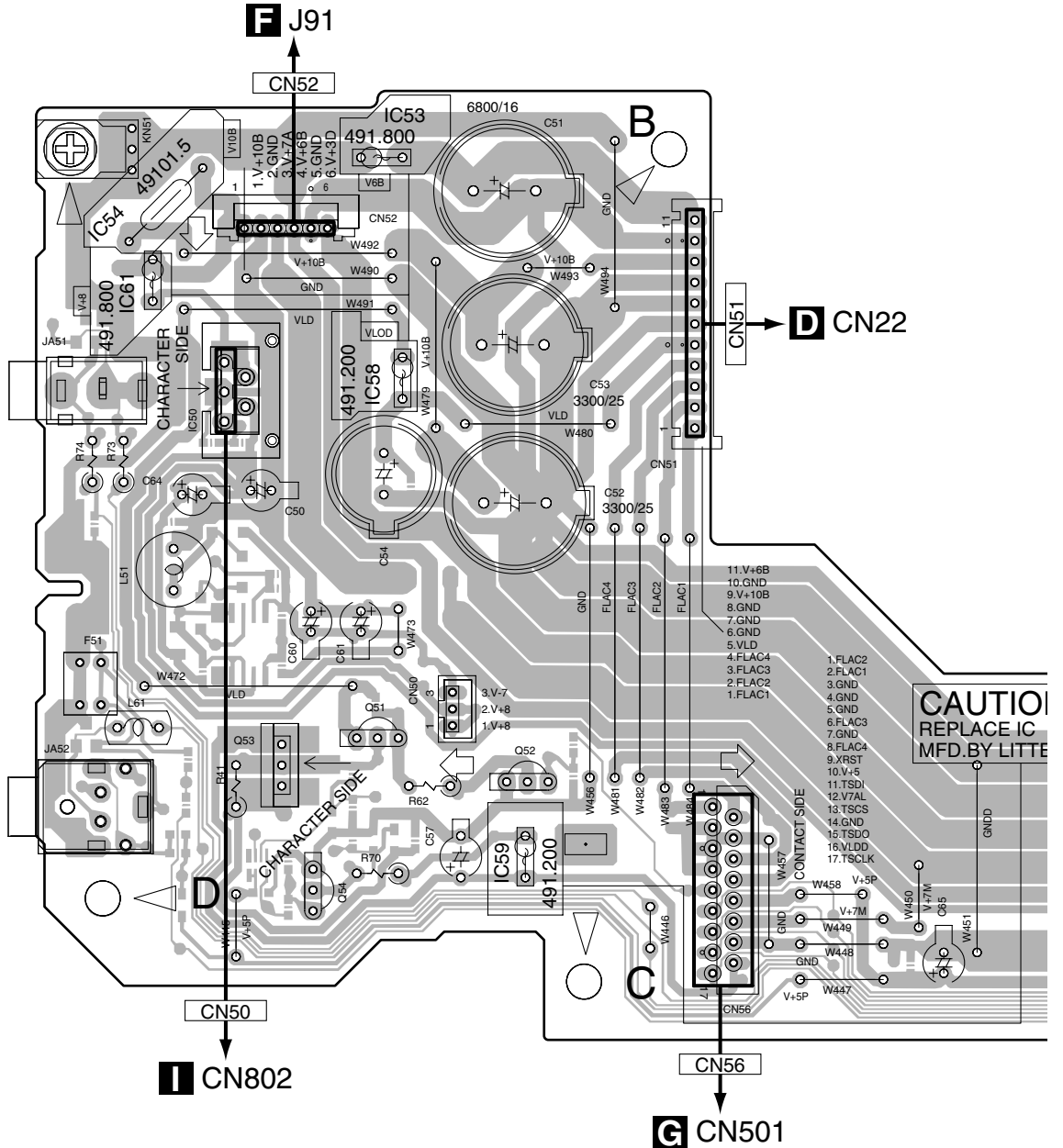

SIDE A

A

B

C

D

E

F

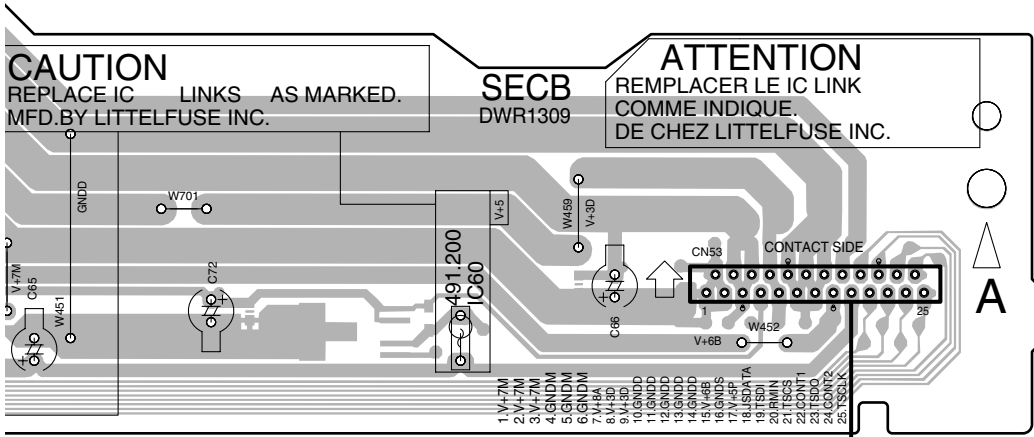

- IC53
- IC54
- IC61
- IC58
IC50
- Q51
- Q52
- IC59
Q54

CN53 (DNP2132-C)

A CN301

SIDE B

A

B

C

D

E

F

C SECB ASSY

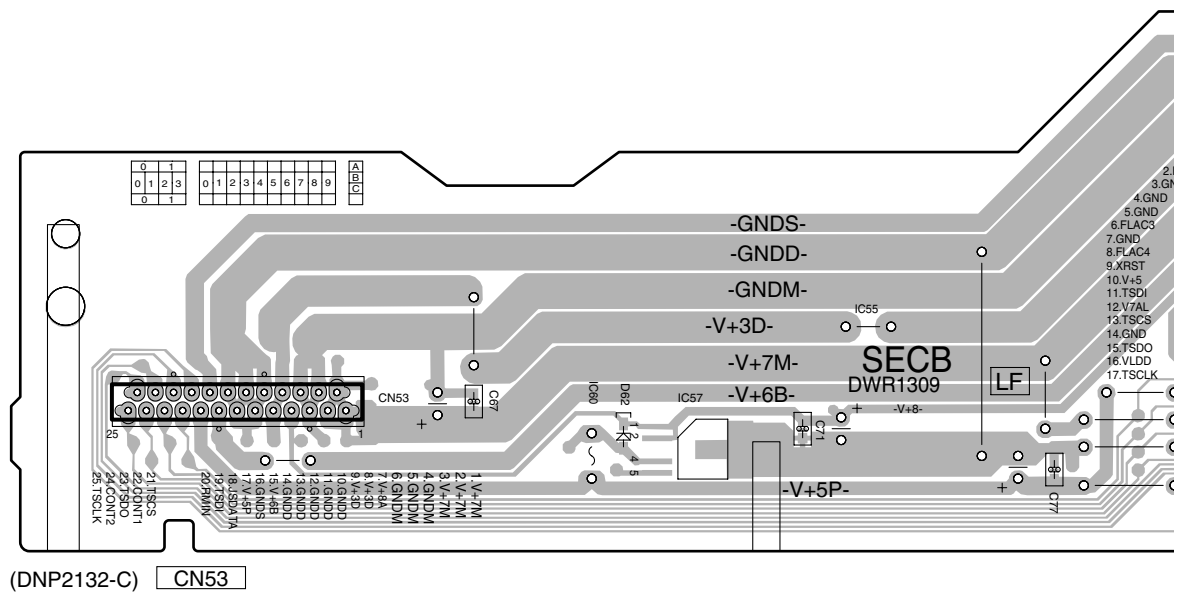

C

4.4 TRNS ASSY

SIDE A

SIDE A

D TRNS ASSY

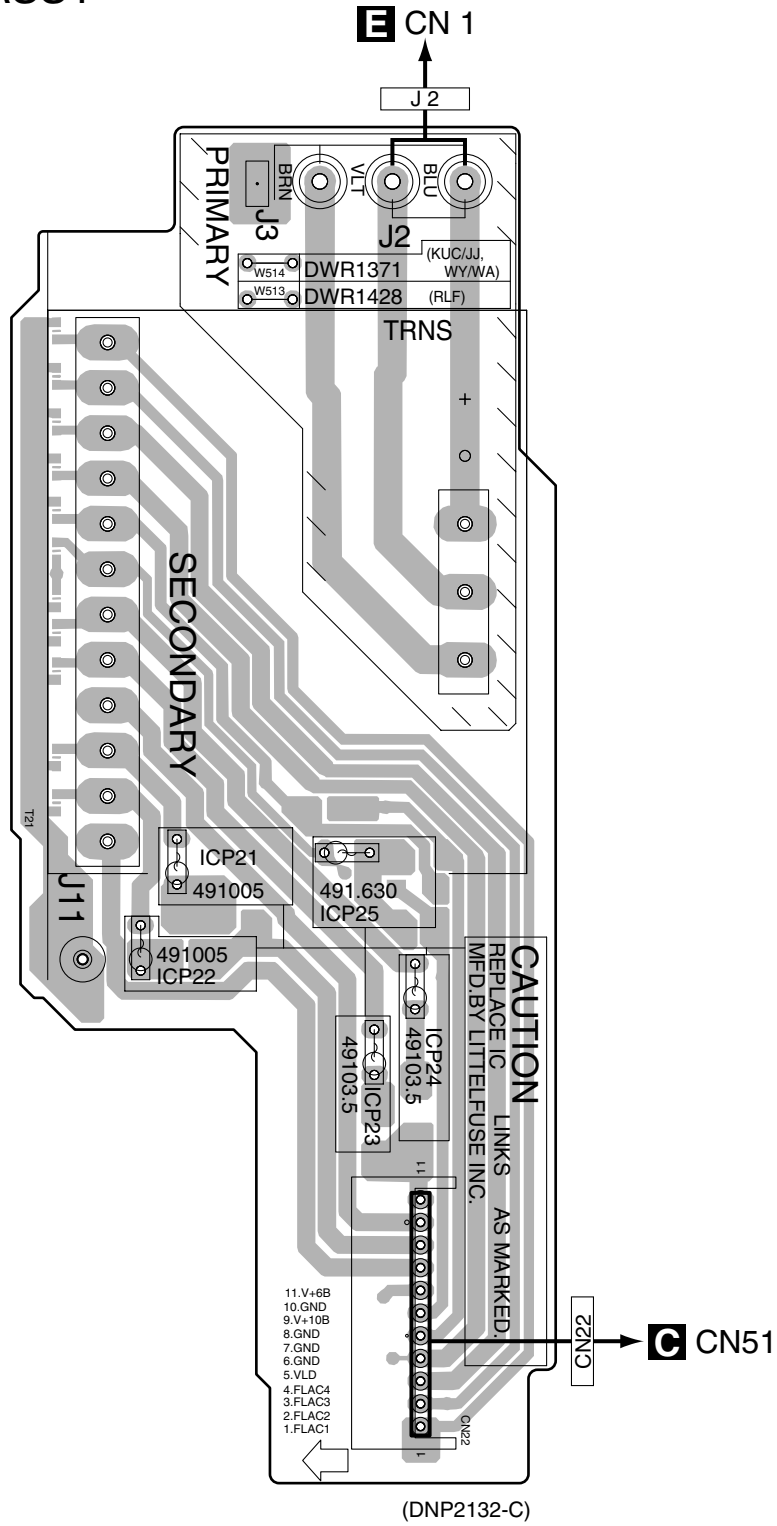

IC22 IC21 IC25 IC23 IC24

CDJ-800MK2

D

D

SIDE B

SIDE B

D TRNS ASSY

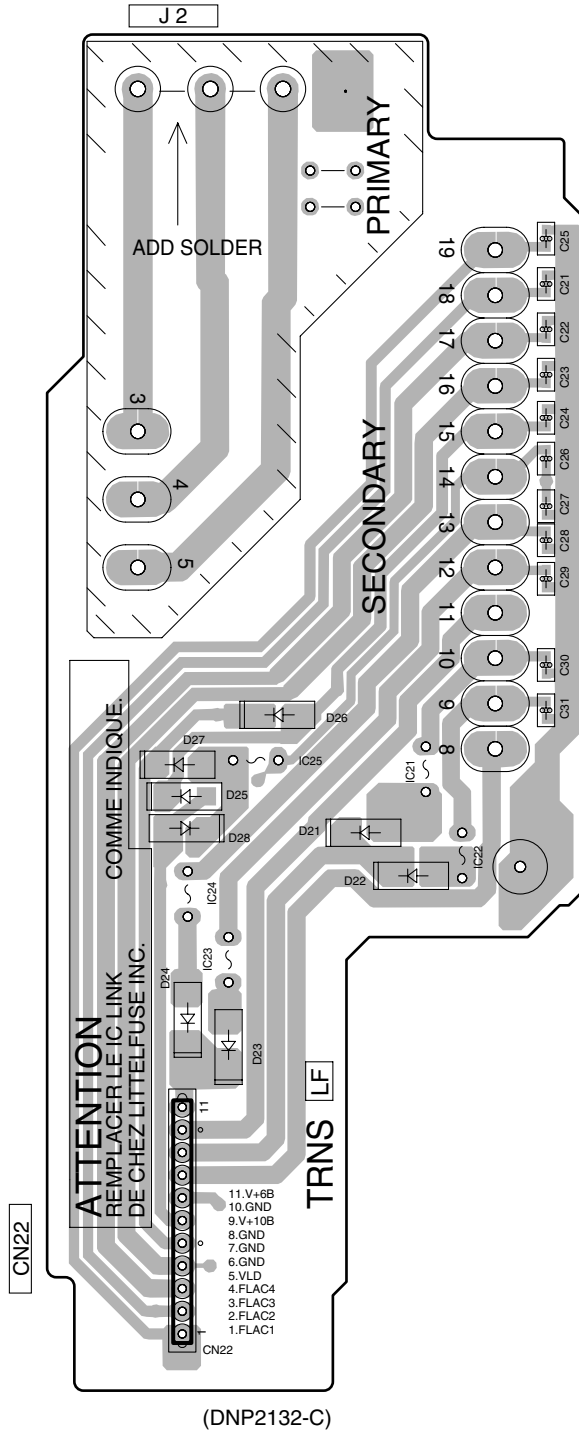

IC24 IC23 IC25 IC21 IC22

D

CDJ-800MK2

D

1 2 3 4

4.5 AC IN ASSYS

SIDE A

SIDE A

E ACIN ASSY

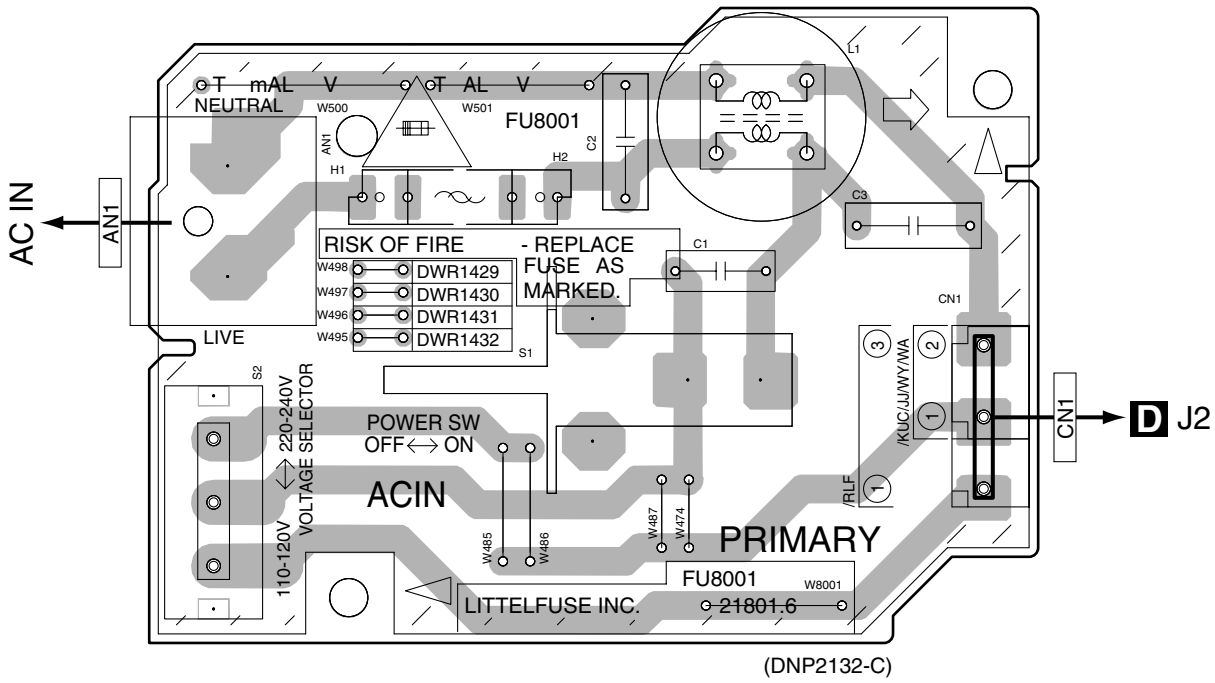

E

E

SIDE B

SIDE B

A

B

C

D

E

F

E ACIN ASSY

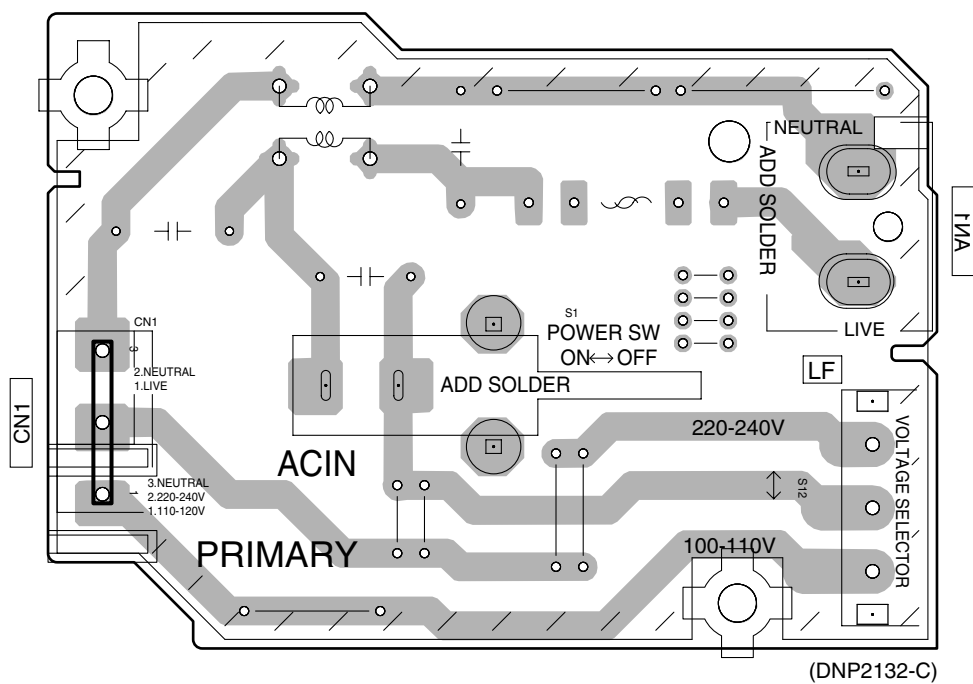

E

E

4.6 DFLB ASSY

SIDE A

G DFLB ASSY

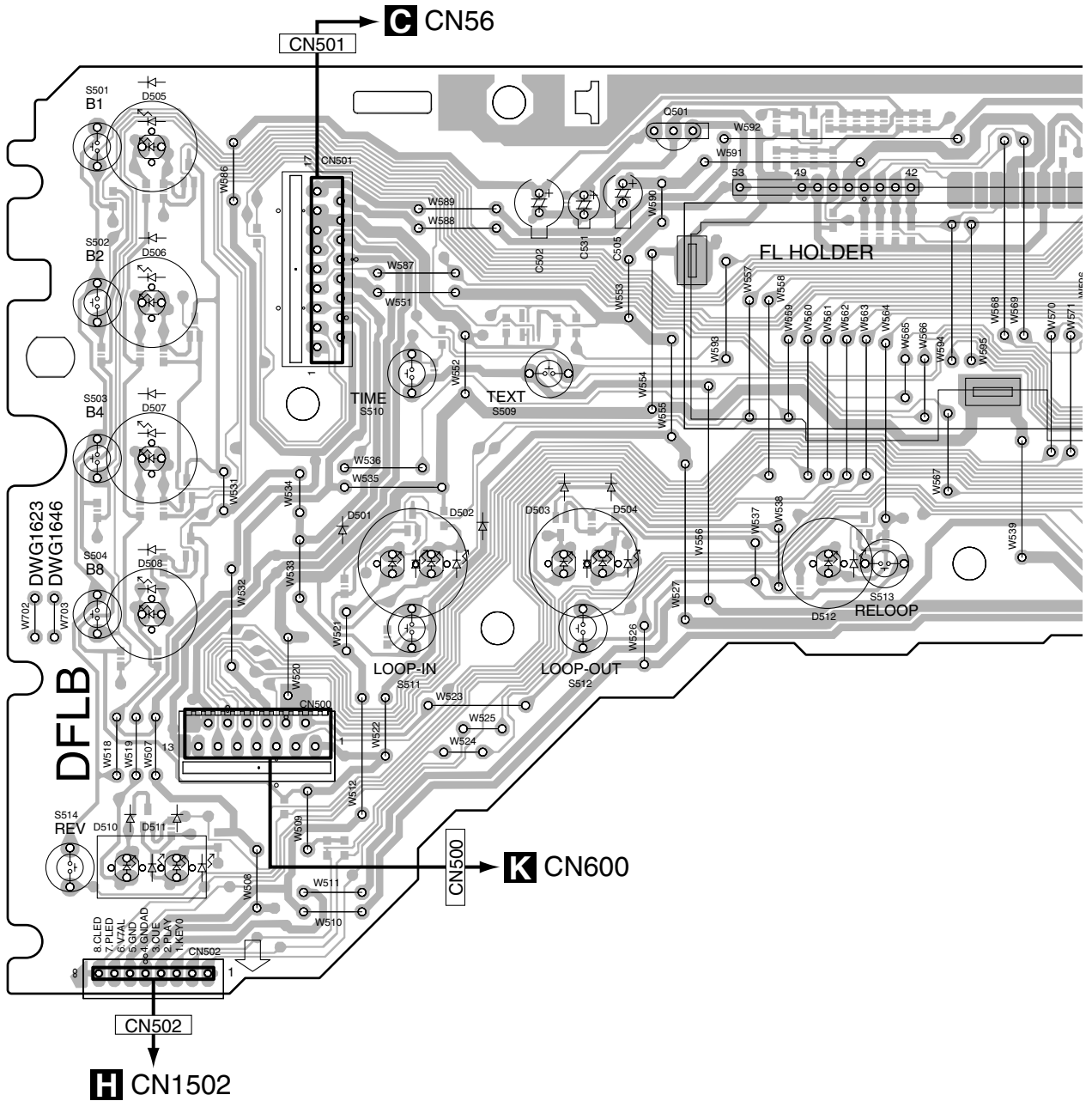

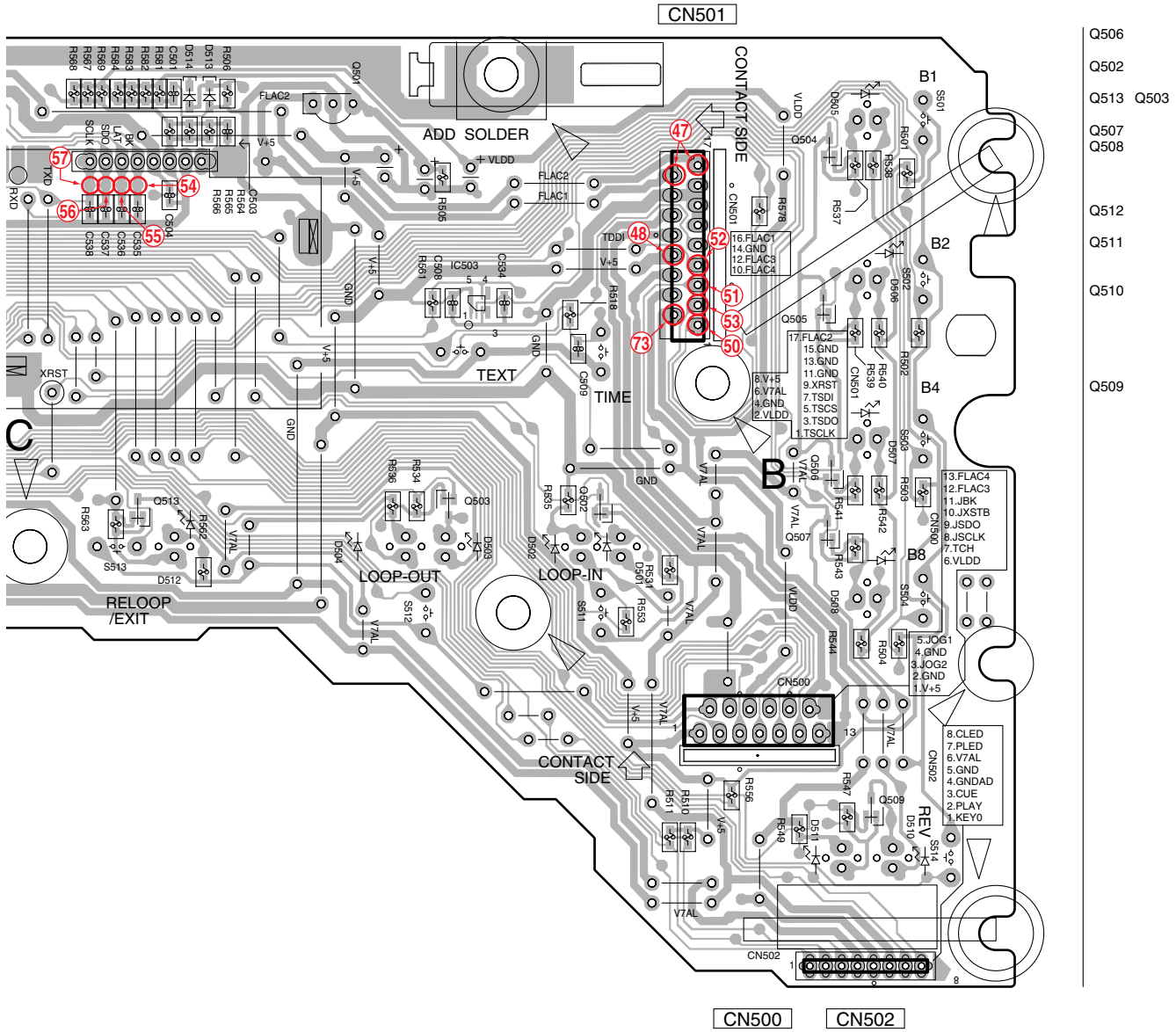

NOTE : The encircled numbers denote measuring point.

4.7 REGB and JACK ASSYS

SIDE A

SIDE A

F REGB ASSY

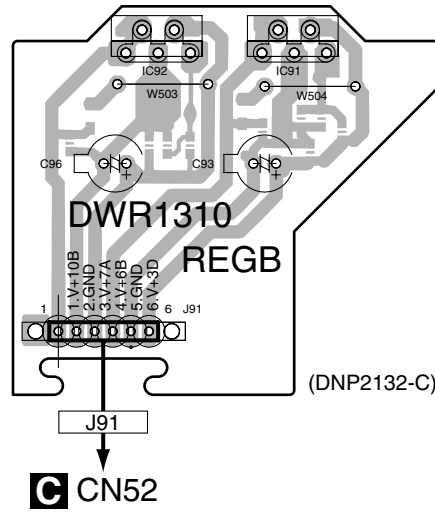

I JACK ASSY

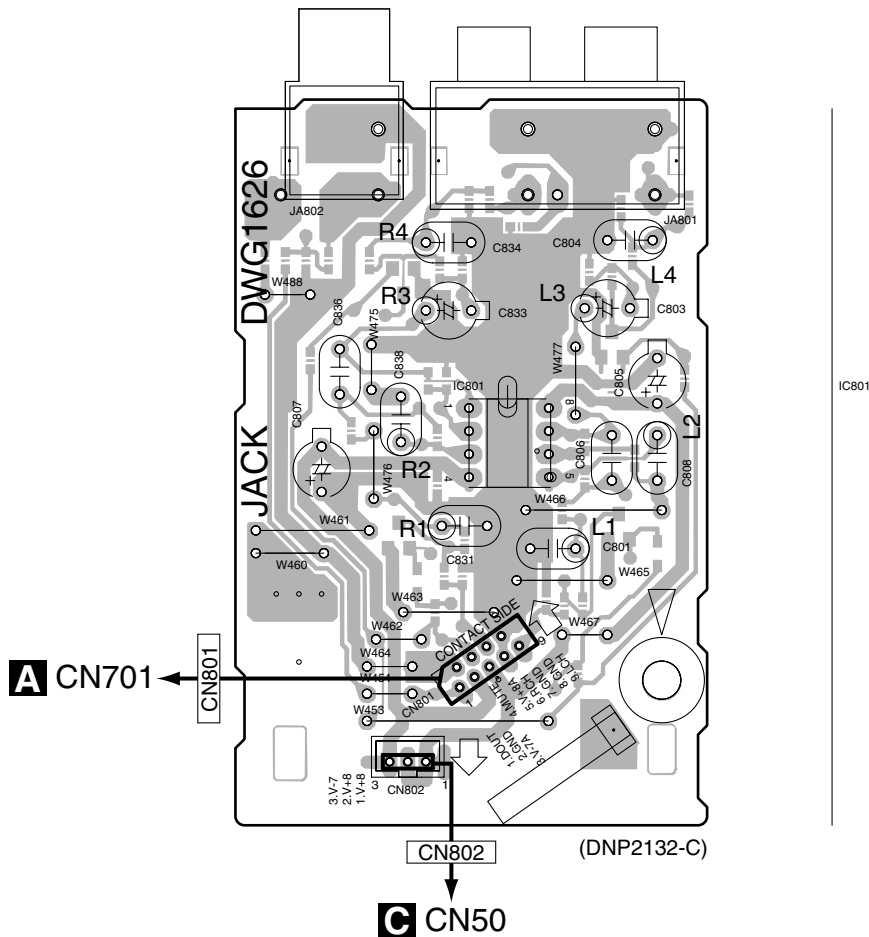

SIDE B

SIDE B

A

B

C

D

E

F

F REGB ASSY

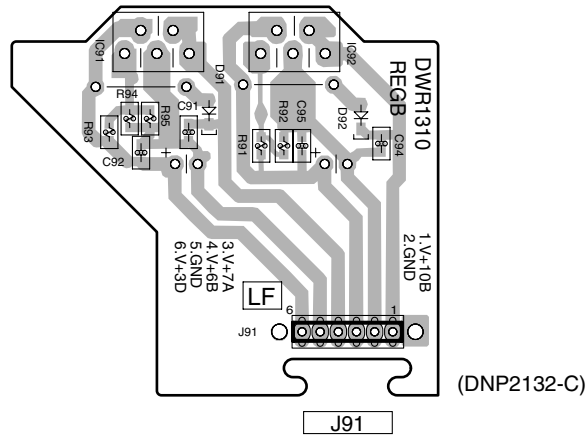

I JACK ASSY

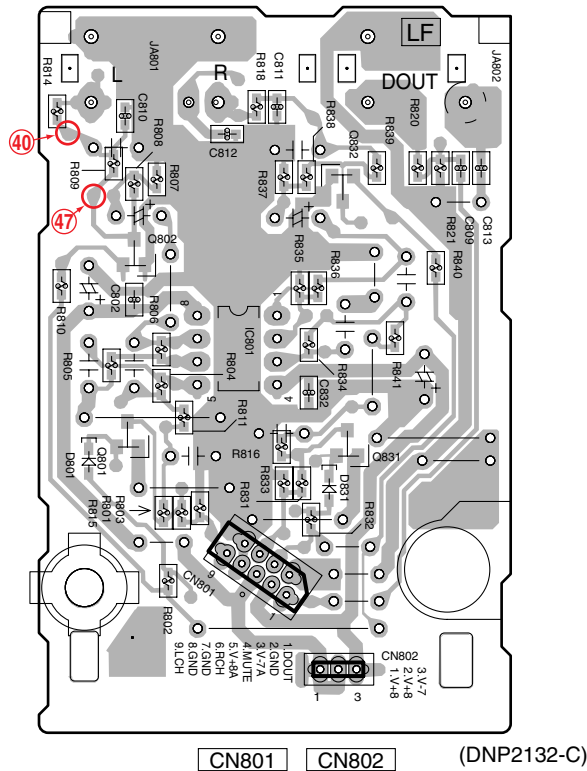

NOTE : The encircled numbers denote measuring point.



1 2 3 4

4.8 KSWB ASSY

SIDE A

SIDE A

H KSWB ASSY

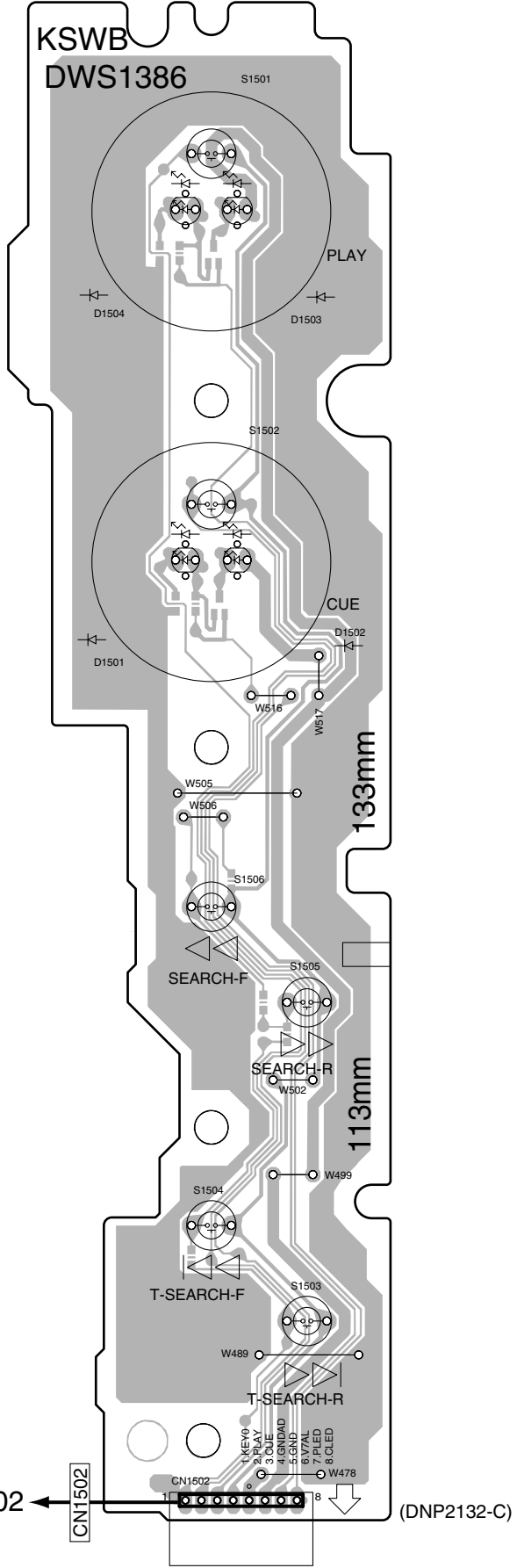

G CN502

(DNP2132-C)

H

H

SIDE B

SIDE B

H KSWB ASSY

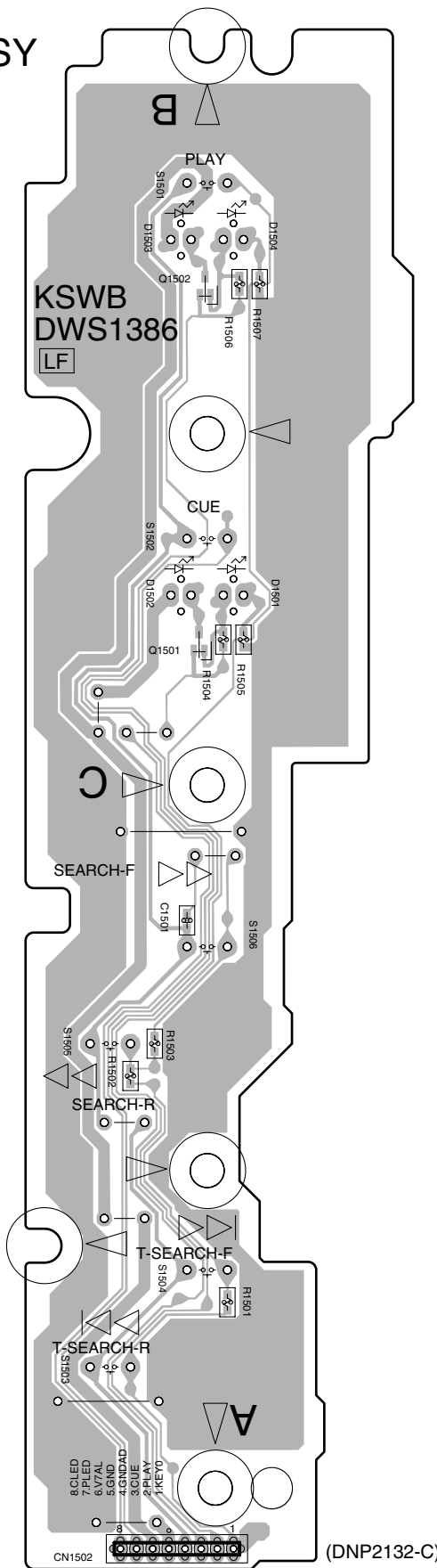

A
B
C
D
E
F



CN1502

4.9 JFLB ASSY

SIDE A

K JFLB ASSY

CAUTION
REPLACE IC 1
MFD. BY LITTELF

ATTEN
REPLACER LE I
COMME INDIQUE
DE CHEZ LITTELI

- 1. FLAC4
- 2. FLAC3
- 3. JBK
- 4. JXSTB
- 5. JSDO
- 6. JSCLK
- 7. TCH
- 8. VLDD
- 9. JOG1
- 10. GNDD
- 11. JOG2
- 12. GNDD
- 13. V+5V

IC603
491.200

G CN500

CN600

L CN1601

Production code

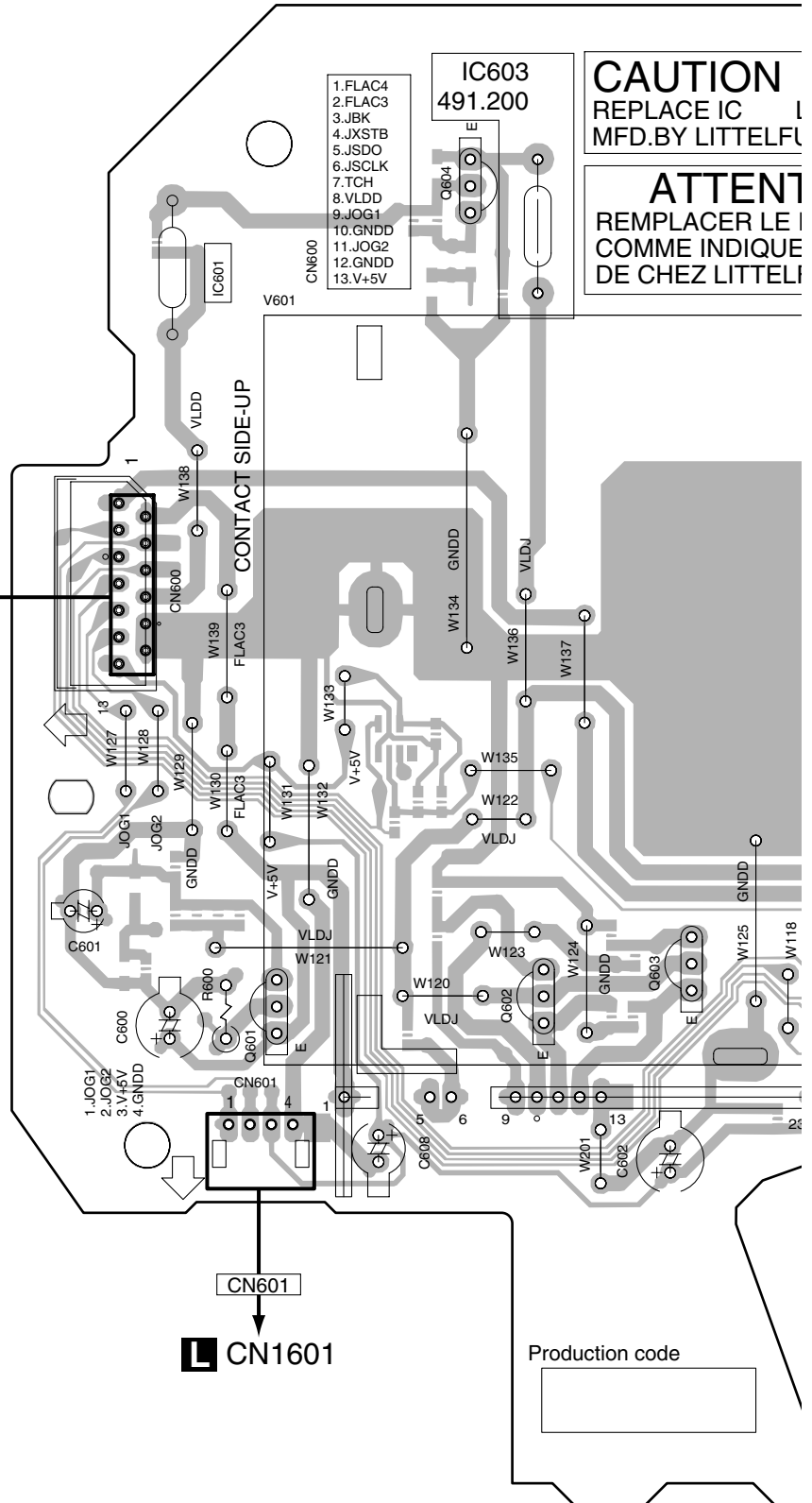

SIDE A

A

CAUTION

PLACE IC LINKS AS MARKED.
D.BY LITTELFUSE INC.

ATTENTION
EMPLACER LE IC LINK
D'APRES L'EMPLACEMENT
INDIQUE.
CHEZ LITTELFUSE INC.

DWG1624
JFLB 2/2

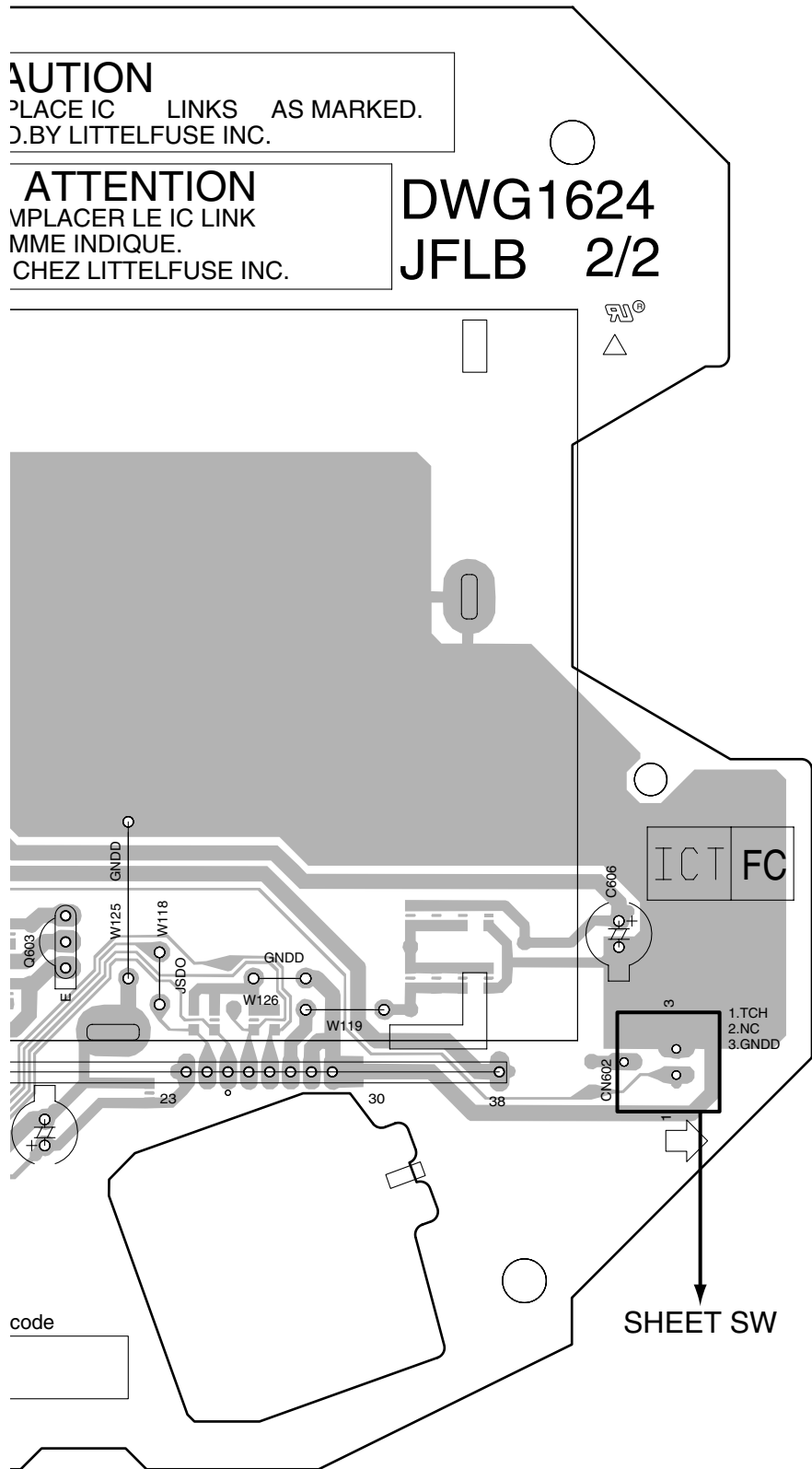

code

(DNP2133-D)

IC603

Q604

IC601

B

C

D

Q603

Q602

Q601

E

SHEET SW

F

SIDE B

A

K JFLB ASSY

B

C

D

E

F

LF

DWG1624 2/2

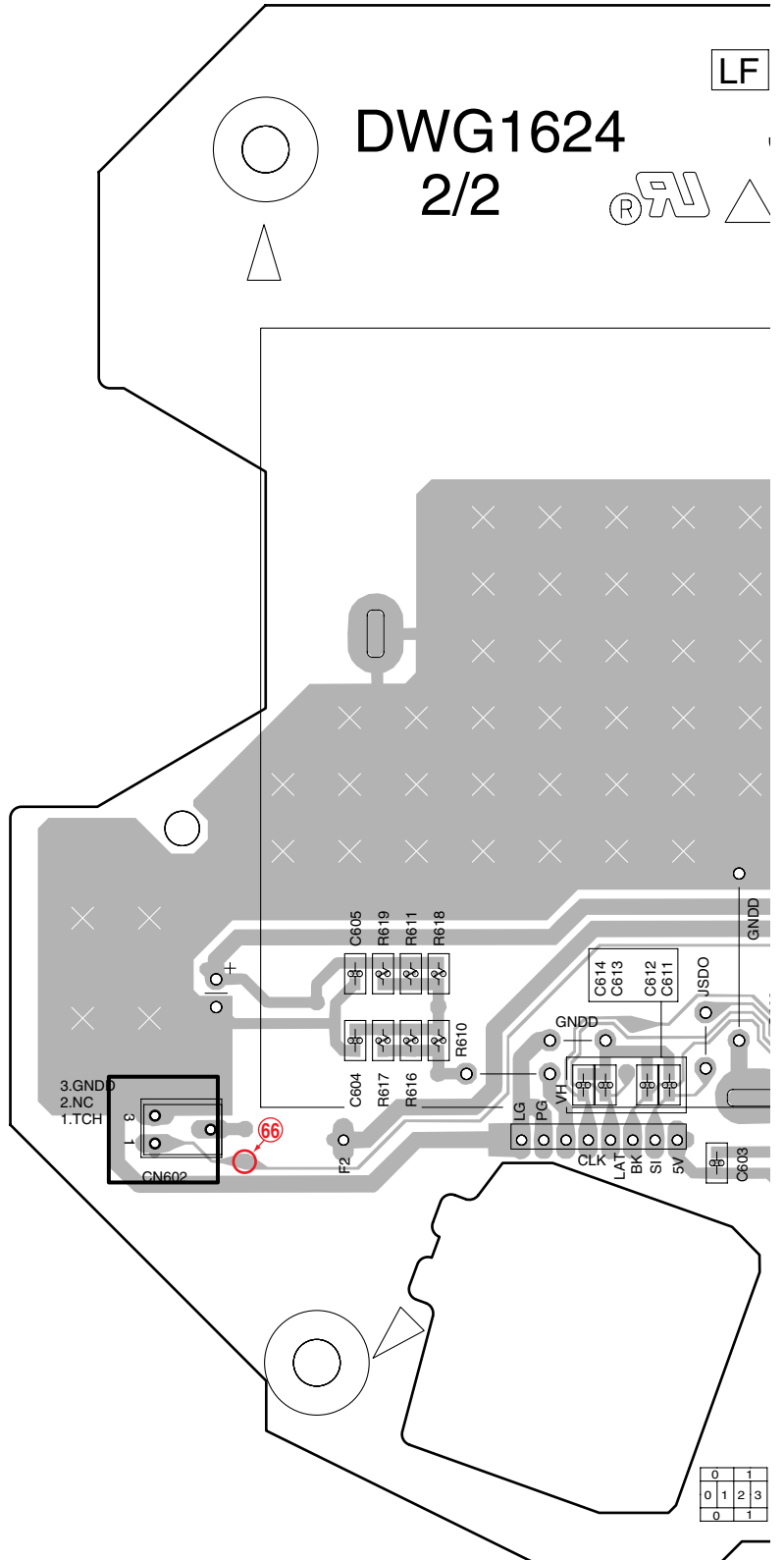

0	1
0	1
0	1

(DNP2133-D)



SIDE A

A

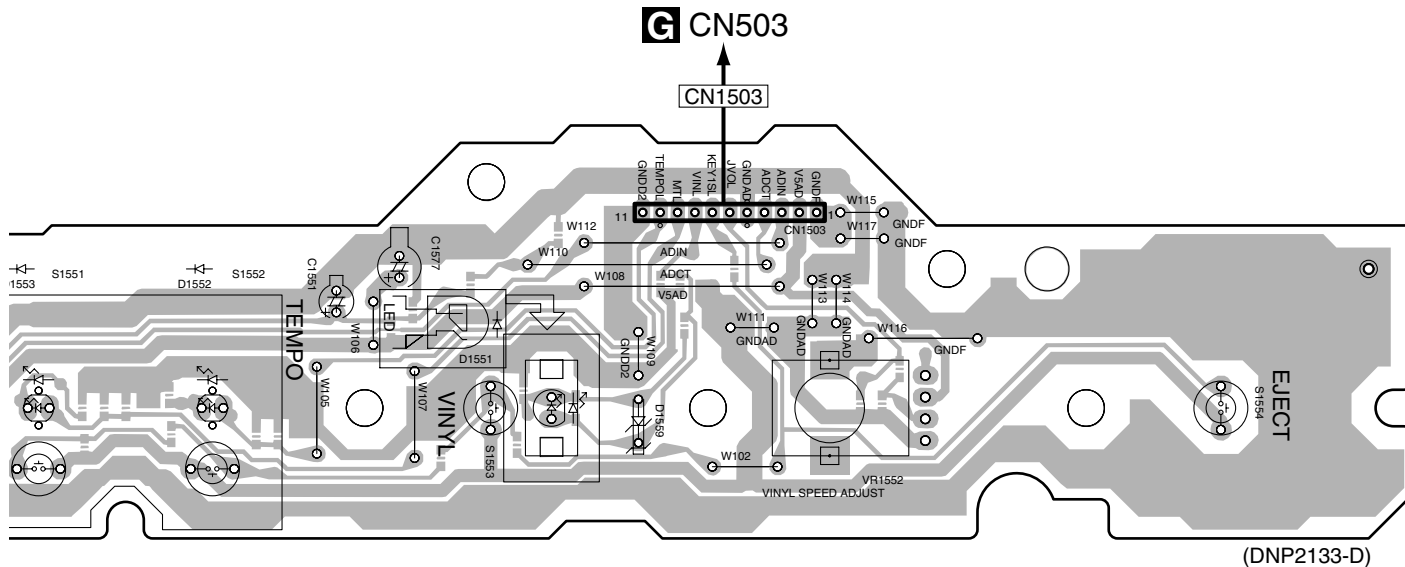

B

C

SIDE B

D

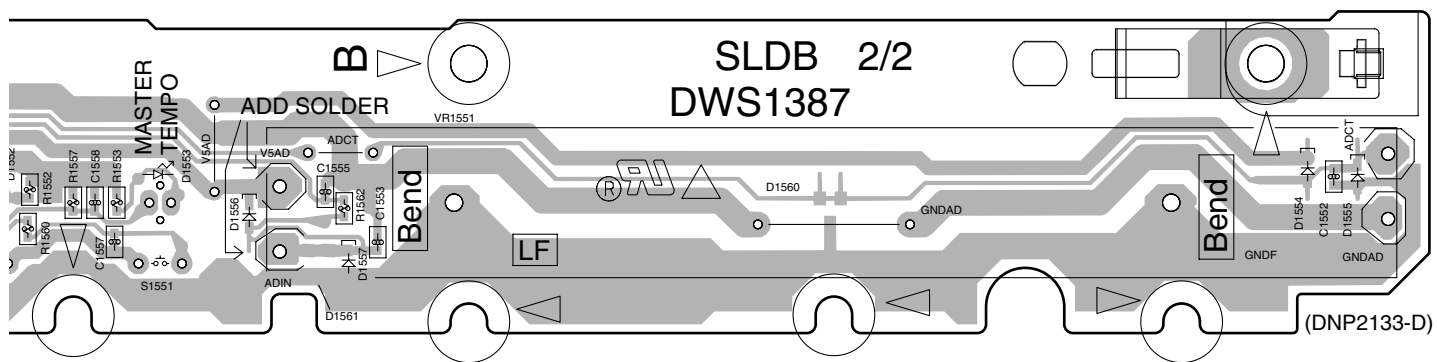

E

NOTE : The encircled numbers denote measuring point.

F

4.11 SLMB and JOGB ASSYS

SIDE A

SIDE A

L JOGB ASSY

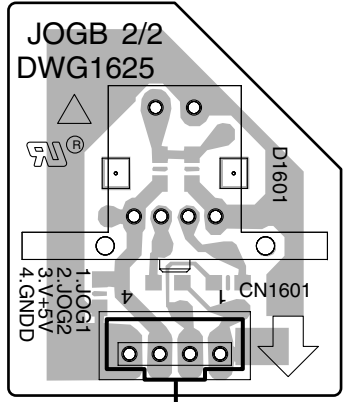

(DNP2133-D)

CN1601

K CN601

M SLMB ASSY

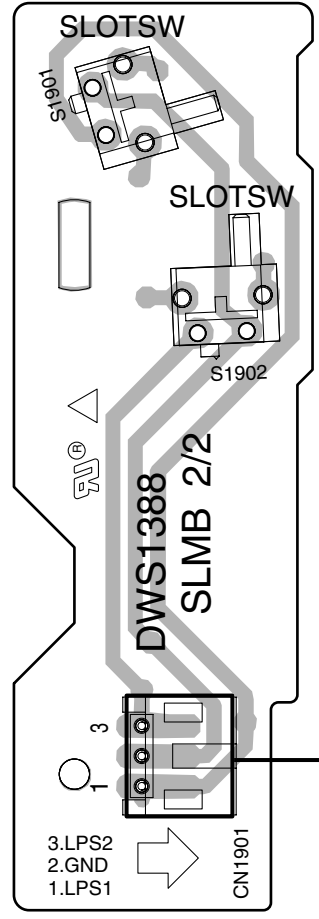

(DNP2133-D)

CN1901

B CN1105

M L

M L

SIDE B

SIDE B

A

B

C

D

E

F

L JOGB ASSY

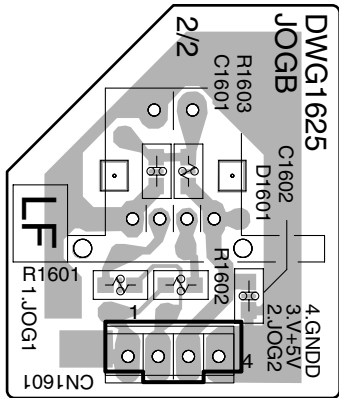

(DNP2133-D)

CN1601

M SLMB ASSY

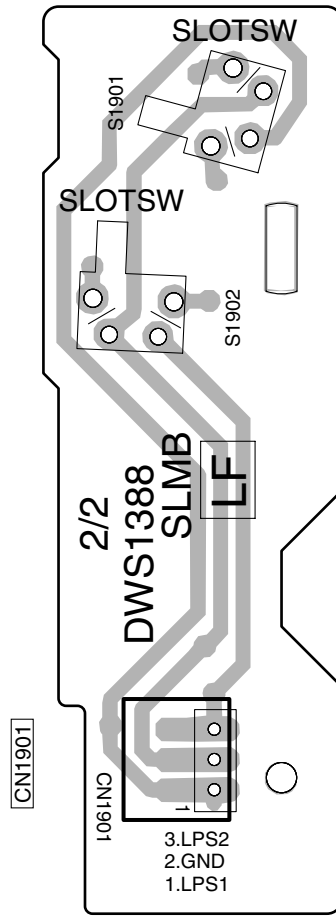

(DNP2133-D)

M L

M L

5. PCB PARTS LIST

NOTES: ● Parts marked by "NSP" are generally unavailable because they are not in our Master Spare Parts List.
 ● The Δ mark found on some component parts indicates the importance of the safety factor of the part. Therefore, when replacing, be sure to use parts of identical designation.
 ● When ordering resistors, first convert resistance values into code form as shown in the following examples.
 Ex.1 When there are 2 effective digits (any digit apart from 0), such as 560 ohm and 47k ohm (tolerance is shown by J=5%, and K=10%).

560 Ω \rightarrow 56×10^1 \rightarrow 561 RD1/4PU $\boxed{5}\boxed{6}\boxed{1}\boxed{J}$
 47k Ω \rightarrow 47×10^3 \rightarrow 473 RD1/4PU $\boxed{4}\boxed{7}\boxed{3}\boxed{J}$
 0.5 Ω \rightarrow R50 RN2H $\boxed{R}\boxed{5}\boxed{0}\boxed{K}$
 1 Ω \rightarrow 1R0 RS1P $\boxed{1}\boxed{R}\boxed{0}\boxed{K}$
 Ex.2 When there are 3 effective digits (such as in high precision metal film resistors).
 5.62k Ω \rightarrow 562×10^1 \rightarrow 5621 RN1/4PC $\boxed{5}\boxed{6}\boxed{2}\boxed{1}\boxed{F}$

LIST OF HOLE PCB ASSEMBLIES

Mark	Symbol and Description	CDJ-800MK2/ KUCXJ	CDJ-200MK2/ WYXJ5	CDJ-800MK2/ RLFXJ
NSP	1..MOTHER ASSY	DWM2232	DWM2232	DWM2232
	2..MAIN ASSY	DWG1622	DWG1622	DWG1622
	2..RLYB ASSY	DWX2602	DWX2602	DWX2602
NSP	1..DISP ASSY	DWM2234	DWM2233	DWM2236
	2..DFLB ASSY	DWG1623	DWG1623	DWG1623
	2..JACK ASSY	DWG1626	DWG1626	DWG1626
	2..SECB ASSY	DWR1309	DWR1309	DWR1309
	2..REGB ASSY	DWR1310	DWR1310	DWR1310
	2..TRNS ASSY	DWR1371	DWR1371	DWR1428
	2..ACIN ASSY	DWR1430	DWR1429	DWR1432
2..KSWB ASSY	DWS1386	DWS1386	DWS1386	
NSP	1..SUB ASSY	DWM2237	DWM2237	DWM2237
	2..JFLB ASSY	DWG1624	DWG1624	DWG1624
	2..JOGB ASSY	DWG1625	DWG1625	DWG1625
	2..SLDB ASSY	DWS1387	DWS1387	DWS1387
	2..SLMB ASSY	DWS1388	DWS1388	DWS1388

CONTRAST OF PCB ASSEMBLIES

ACIN ASSY

DWR1430, DWR1429 and DWR1432 are constructed the same except for the following :

Mark	Symbol and Description	DWR1430	DWR1429	DWR1432
Δ	AN1 1P AC INLET	XKP3042	XKP3041	XKP3041
Δ	CN1 2P VH CONNECTOR	B2P3-VH	B2P3-VH	B2P3-VH
Δ	CN1 3P VH CONNECTOR	Not used	Not used	B3P5-VH
Δ	S2 VOLTAGE SELECTOR	Not used	Not used	DSA1026

TRNS ASSY

DWR1371 and DWR1428 are constructed the same except for the following :

Mark	Symbol and Description	DWR1371	DWR1428
Δ	J2 CONNECTOR ASSY	DKP3621	Not used
Δ	J3 CONNECTOR ASSY	Not used	DKP3720

Mark No.	Description	Part No.
Q51		2SB1238X
Q52, Q54		2SD1859X
△Q53		2SD2012
A		
D55		1SS355
D51, D58, D59		EP05Q04
D56, D57		NNCD6.2MF
D53		UDZS30(B)
D52		UDZS5R1(B)

Mark No.	Description	Part No.
CAPACITORS		
C21-C31		CKSRYB473K50
OTHERS		
△J2		DKP3621
CN22	11P CONNECTOR	S11B-XH-A-1
	PCB BINDER	VEF1040

COILS AND FILTERS

L56	CTF1386
L51	DTL1083
L61	LRCA180J

D TRNS ASSY (DWR1428)**SEMICONDUCTORS**

△IC25	AEK7006
△IC23, IC24	AEK7017
△IC21, IC22	AEK7019
△D25-D28	1SR154-400
△D21-D24	RB060L-40

CAPACITORS

C21-C31	CKSRYB473K50
---------	--------------

OTHERS

△J3	CONNECTOR ASSY	DKP3620
CN22	11P CONNECTOR	S11B-XH-A-1
	PCB BINDER	VEF1040

E ACIN ASSY (DWR1429)**COILS AND FILTERS**

△L1	VTL-004
-----	---------

SWITCHES AND RELAYS

△S1	RSA1001
-----	---------

CAPACITORS

△C2, C3	ACE7027
△C1	ACG7033

OTHERS

H1, H2	FUSE CLIP	AKR1004
△CN1	2P-VH CONNECTOR	B2P3-VH
△AN1	AC INLET 1P	XKP3041

E ACIN ASSY (DWR1430)**COILS AND FILTERS**

△L1	VTL-004
-----	---------

SWITCHES AND RELAYS

△S1	RSA1001
-----	---------

CAPACITORS

△C2, C3	ACE7027
△C1	ACG7033

OTHERS

H1, H2	FUSE CLIP	AKR1004
△CN1	2P-VH CONNECTOR	B2P3-VH
△AN1	AS INLET 1P	XKP3042

D TRNS ASSY (DWR1371)**SEMICONDUCTORS**

△IC25 (630 mA)	AEK7006
△IC23, IC24 (3.5 A)	AEK7017
△IC21, IC22 (5.0 A)	AEK7019
△D25-D28	1SR154-400
△D21-D24	RB060L-40

F

5	6	
Mark No.	Description	Part No.
E	ACIN ASSY (DWR1432)	
	COILS AND FILTERS	
△ L1	VTL-004	
	SWITCHES AND RELAYS	
△ S2	DSA1026	
△ S1	RSA1001	
	CAPACITORS	
△ C2, C3	ACE7027	
△ C1	ACG7033	
F	REGB ASSY	
	SEMICONDUCTORS	
△ IC91, IC92	BA00BC0WCP-V5	
	CAPACITORS	
C93, C96	CEHAR101M10	
C91, C92, C94, C95	CKSRYB103K50	
	RESISTORS	
R93	RS1/16S1002F	
R94, R95	RS1/16S1202F	
R91	RS1/16S3902F	
R92	RS1/16S8201F	
	OTHERS	
6P CABLE HOLDER	51048-0600	
J91 JUMPER WIRE	D20PDY0610E	
REGULATOR PLAT	DNH2707	
G	DFLB ASSY	
	SEMICONDUCTORS	
IC502	BU4242G	
IC501	PEG237B	
IC503	TC7SET08FUS1	
Q501	2SB1237X	
Q502-Q513	2SC4081	
D515	1SS355	
D510, D511	SLI-343URCW(RST)	
D501-D508, D512	SLI-343YCW(RST)	
D509	TLGE68TG(NP)	
D514	UDZS6R2(B)	
	COILS AND FILTERS	
X501 (16.0 MHz)	DSS1149	
	SWITCHES AND RELAYS	
S501-S504, S511-S514	DSG1079	
S505-S510, S515-S517	VSG1024	
	CAPACITORS	
C532, C533, C538	CCSRCH120J50	

7	8	
Mark No.	Description	Part No.
C534	CCSRCH121J50	
C535-C537	CCSRCH330J50	
C531	CEHAR100M16	
C506	CEHAR101M10	
C502	CEHAR220M35	
C505	CEHAR330M10	
C511-C520, C523-C525	CKSRYB102K50	
C501, C507, C526-C529	CKSRYB103K50	
C504, C508	CKSRYB104K16	
C521, C522	CKSRYB105K6R3	
C503	CKSRYF104Z50	
	RESISTORS	
Other Resistors	RS1/16S###J	
	OTHERS	
CN500 FFC BOTTOM CONNECTOR	13P52492-1320	
CN501 FFC BOTTOM VONNEVTOR	17P52492-1720	
V501 VFD	DEL1059	
FL HOLDER	DNF1736	
CN502 8P SOCKET	KP200IB8L	
CN503 B TO B CONNECTOR 11P	VKN1363	
H	KSWB ASSY	
	SEMICONDUCTORS	
Q1501, Q1502	2SC4081	
D1501, D1502	SLI-343YCW(RST)	
D1503, D1504	TLGE68TG(NP)	
	SWITCHES AND RELAYS	
S1501, S1502	DSG1079	
S1503-S1506	VSG1024	
	RESISTORS	
Other Resistors	RS1/16S###J	
	OTHERS	
CN1502 8P PLUG	AKM7032	
I	JACK ASSY	
	SEMICONDUCTORS	
IC801	NJM4558DX	
Q801, Q802, Q831, Q832	2SD2114K	
D801, D831	1SS355	
	CAPACITORS	
C803, C805, C807, C833	CEHAT101M16	
C802, C809, C832	CKSRYB104K16	
C801, C804, C831, C834	CQMBA102J50	
C806, C808, C836, C838	CQMBA152J50	
	RESISTORS	
R806, R836	RN1/16SE1102D	
Other Resistors	RS1/16S###J	

1

2

3

4

Mark No. **Description****Part No.****Mark No.** **Description****Part No.****OTHERS**

CN802 KR CONNECTOR 3P
 JA801 2P JACK
 JA802 1P JACK
 PCB BINDER
 CN801 9P FFC CONNECTOR

B3B-PH-K
 DKB1053
 PKB1033
 VEF1040
 VKN1240

OTHERS

CN602 CONNECTOR
 V601 FL INDICATOR
 FL HOLDER
 CN600 FFC CONNECTOR 13P
 CN601 KR CONNECTOR

CKS1072
 DEL1058
 DNF1735
 HLEM13R-1
 S4B-PH-K

**J SLDB ASSY
SEMICONDUCTORS**

D1554-D1557
 D1551
 D1553
 D1552

1SS355
 E1L4E-9B1A(PQ)
 SLI-343URCW(RST)
 SLI-343YCW(RST)

**L JOGB ASSY
SEMICONDUCTORS**

D1601

GP1A038RBK

CAPACITORS

C1601, C1602

CKSRYB103K50

SWITCHES AND RELAYS

S1551-S1554

VSG1024

RESISTORS

Other Resistors

RS1/16S###J

CAPACITORS

C1551
 C1552, C1553
 C1558-C1561

CEHAR100M16
 CKSRYB102K50
 CKSRYB103K50

OTHERS

CN1601 KR CONNECTOR

B4B-PH-K

**M SLMB ASSY
SWITCHES AND RELAYS**

S1901, S1902

DSG1017

OTHERS

CN1901 KR CONNECTOR

S3B-PH-K

OTHERS

CN1503 B-B CONNECTOR

DKN1289

**K JFLB ASSY
SEMICONDUCTORS**

△ IC603
 Q601
 Q602, Q603
 Q604
 D603

AEK7057
 2SB1237X
 2SC1815
 2SD1858X
 1SS355

D604
 D605
 D601

UDZS13(B)
 UDZS15(B)
 UDZS8R2(B)

CAPACITORS

C611-C614
 C601
 C600, C602
 C606
 C608

CCSRCH221J50
 CEHAR100M16
 CEHAR101M10
 CEHAR220M35
 CEHAR330M10

C607
 C603, C605, C609
 C604

CKSRYB102K50
 CKSRYB103K50
 CKSRYF104Z50

RESISTORS

R600
 Other Resistors

RD1/2VM680J
 RS1/16S###J

1

2

3

4

6. ADJUSTMENT

• Mode for checking the load on the Jog dial

It is the mode which judges the load (light/-- heavy) numerically when rotating JOG dial.

If it goes into the above-mentioned check mode of button and display function of the display part, a TOUCH/RELEASE knob is made in the maximum (right-hand side) and arbitrary buttons are pushed once, it will become JOG load check mode and top speed and time will displayed on a dot-matrix part.

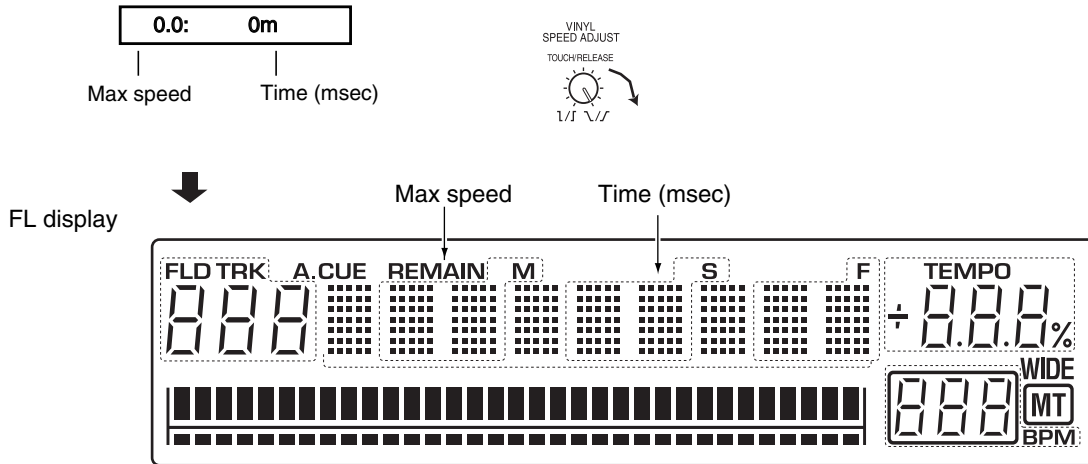

Measuring method

In this state, if you rotate the Jog dial rapidly either clockwise or counterclockwise, figures are displayed.

For example, if "16.14 0135" is displayed, it means as follows:

16.14: Highest speed (given that the normal [1x] speed is when it takes 1.8 sec for the Jog dial to rotate one full turn.)

0135: Time (msec) required for the Jog dial to decrease its speed from 3x speed to 1.5x speed

As to the time required for the Jog dial to decrease its speed, if the measurement is performed for several times repeatedly, from the second measurement and afterward, the average of the current required time and the previous required time is displayed. Thus, after several measurements, the result becomes closer to the mean.

Notes

- Perform the measurement of load on the Jog dial more than three times.
- The measurement result is displayed only when the Jog dial is rotated 7 times normal speed "07.00" or more.

Management value

Jog management value: 150 ± 25 (msec)

Load adjustment method

Remove the screw fixing the adjust plate, then screw it into the hole corresponding to the value (-1, -2, -3, +1, or +2) for a load to be added:

-1, -2, -3 : To decrease the load

+1, +2 : To increase the load

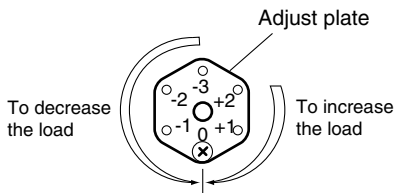

JOG Check Mode : CANCEL



7. GENERAL INFORMATION

7.1 DIAGNOSIS

7.1.1 SERVICE MODE

1. The outline in service mode

This machine is controlled by two microcomputers, a display microcomputer and a player microcomputer, and test mode is prepared for each. A display microcomputer performs processing to a button input, display of FL, and lighting of LED. A player microcomputer drives a player.

- [1] Check mode of a button and a display function of a display microcomputer.
It is the mode which checks a button input and a display function.
- [2] Check mode of the load of JOG dial
It is the mode which measures the load when rotating JOG dial.
- [3] Check mode of operation of a player microcomputer
It is the mode which performs the check of the mechanism and serbo of a player microcomputer of operation.
This mode consists of "player operation mode" and "test operation mode."
- [4] Version check mode
It is the mode which can check the version of the software of each microcomputer.
- [5] Error display list / Error display mode
The history of the contents of an error can be checked to 16 pieces.

2. Check mode of a button and a display function of a display microcomputer.

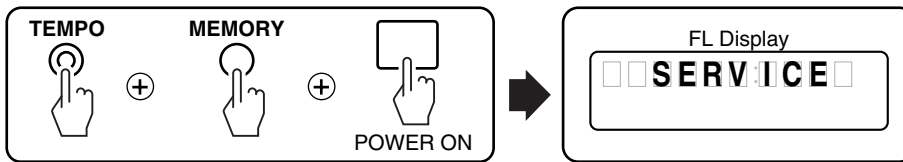

In this mode, it can check whether a display microcomputer can be made to turn on partially as follows, the input of each button and volume is normal, and a display is normal. In addition, a display is turned on only while pushing the button.

If a TOUCH/RELEASE knob is made into states other than the maximum (right-hand side), it will become the check mode of button and display function, and if each button is pushed, FL display and LED which correspond light up. Moreover, if a knob is made into the maximum (right-hand side) and arbitrary buttons are pushed once, it will become JOG load check mode and top speed and time will be displayed on a FL dot-matrix part. (After-mentioned)

Button, Switch	FL Dot-matrix display	FL Other display	Light up LED
PLAY/PAUSE	PLAY		PLAY/PAUSE
CUE	CUE		CUE
IN/REALTIME CUE	IN		IN/REALTIME CUE
OUT/OUT ADJUST	OUT		OUT/OUT ADJUST
RELOOP/EXIT	RELOOP		RELOOP
FOLDER <-	FOLDER <-		
FOLDER ->	FOLDER ->	1G lights up	
TRACK (I<<)	TRACK I<<		
TRACK (>>I)	TRACK >>I	(1)	
REV (<<)	REV <<	(2)	
FWD (>>)	FWD >>	(3)	
BEAT LOOP 1	BEAT 1		BEAT LOOP 1
BEAT LOOP 2	BEAT 2		BEAT LOOP 2
BEAT LOOP 4	BEAT 4		BEAT LOOP 4
BEAT LOOP 8	BEAT 8		BEAT LOOP 8
JOG MODE	JOG MODE		VINYL
TEMPO	TEMPO	(5)	TEMPO 10%/WIDE
MASTER TEMPO	MASTER TE		MASTER TEMPO
QUICK RETURN	QUICK RET		QUICK RETURN
TIME MODE/AUTO CUE	TIME/ACUE		
TEXT MODE	TEXT MODE		
DELETE	All FL lights up	All FL lights up	All LED lights up
MEMORY	MEMORY		
EJECT	EJECT		
CUE/LOOP CALL <	CALL <		
CUE/LOOP CALL >	CALL >		
REVERSE	REVERSE		
TOUCH SENSOR	TOUCH SW	(4)	REV
JOG rotating to FWD	JOG >		
JOG rotating to REV	< JOG		

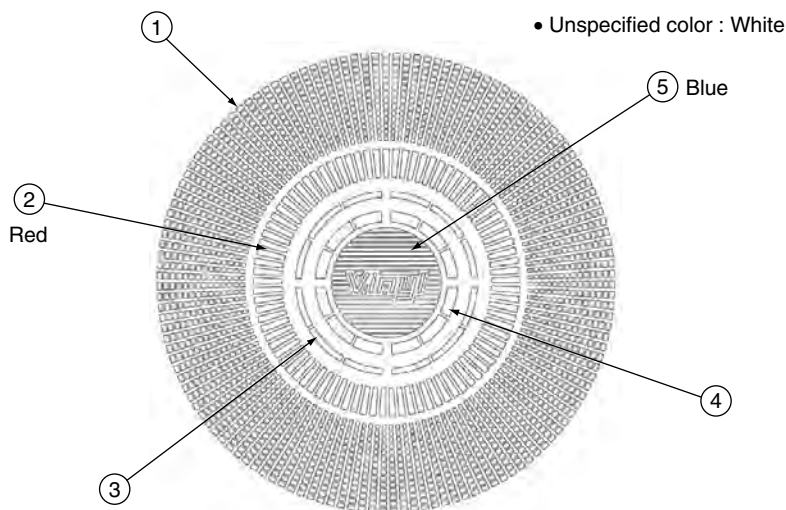
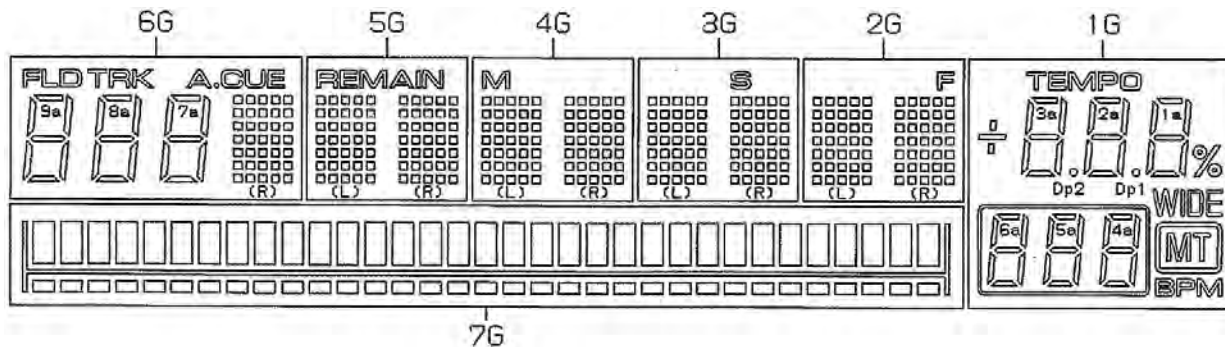

A display of TOUCH/RELEASE and TEMPO slider reading value

TOUCH/RELEASE and the TEMPO slider reading value is displayed in the form of a bar in 7G area of FL display part.

CUE Area : If a TOUCH/RELEASE knob is turned to the right, the number of display dots will increase.

Playing Address : If TEMPO slider knob is moved to + side, the number of display dots will increase.

3. Check mode of the load of JOG dial

It is the mode which judges the load (light/-- heavy) numerically when rotating JOG dial.

If it goes into the above-mentioned check mode of button and display function of the display part, a TOUCH/RELEASE knob is made in the maximum (right-hand side) and arbitrary buttons are pushed once, it will become JOG load check mode and top speed and time will be displayed on a dot-matrix part.

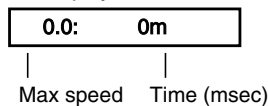

It goes into this mode, and a number will be displayed if JOG dial is turned with sufficient vigor.

the rotation direction -- right-handed rotation and left-handed rotation -- either is O.K.

For example, when displayed as "8.6: 115", the following contents are shown, respectively.

8.6 = What time speed came out by the highest. (The time of turning one rotation in 1.8 seconds is made into 1 time.)

115 = Time taken for rotation to fall by 1.5 times from 3 times (msec)

It is necessary to make it rotate top speed to 7.0 or more times to measure the rotation fall time required.

When it carries out continuously several times, the time which took the average with a part for greatest ever 4 time is displayed 2nd henceforth. Measurement which absorbed variation can be performed by performing this.

4. Check mode of operation with a player microcomputer simple substance

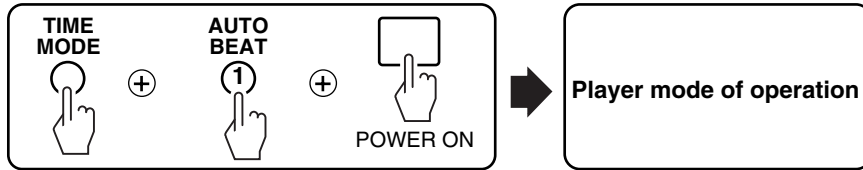

This mode consists of "player operation mode" and "test operation mode."

< Player operation mode >

Basic operation of SABO, such as setup, play, pause, and track search, is carried out. Moreover, measurement of an error rate can also be performed.

< Test operation mode >

Servo operation is finely controllable gradually.

* It becomes player operation mode and shifts to test operation mode by the key input in the beginning.

* The command treated here is for mainly testing a mechanism and a servo system, and is not for DJ functions, such as scan and tempo.

B

Function	The button of the main body
< Player operation mode >	
Play(trace) / Pause	PLAY/PAUSE
Track Search F/R	TRACK SEARCH F/R
Error Rate Count	CUE
Eject	EJECT
Mode Change	MASTER TEMPO
< Test operation mode >	
Servo All Off	TIME
LD On/Off	TEMPO
Focus On/Off	RELOOP
Spindle Kick, Tracking On/Off	LOOPIN
Tracking Off	LOOPOUT
Slide FWD (2mm)	SEARCH FWD
Slide REV (2mm)	SEARCH REV
Pickup Up/Down	TEXT
Mode Change	MASTER TEMPO

◆ Player operation mode command

Play(trace) / Pause

If it is in a stop state, it will set up and play.

Moreover, if it is in a play state, whenever it will push a button, a pause and a play are carried out by turns.

The address under present reproduction is displayed on FL.

* In this mode, even if it inserts a disk, an automatic setup is not carried out.

Moreover, a play is not carrying out audio reproduction, but is tracing the signal side of a disk.

At a play, a disk is traced by 4X rotation. A sound is not outputted.

Track Search F/R

It searches in the direction of FWD or REV and stops in of the displayed track.

Error Rate Count

The error rate for about 10 seconds after the present position currently played is measured, and it displays on FL.

Usually, a track to measure is made to search and this button is inputted from a pause state.

For example, it is displayed as "3.56E-4 O.K." etc.

If an error rate is less than 3.00E-3, it will be displayed as O.K. If an error rate is larger than 3.00E-3, it will be displayed as NG.

Measurement with the managed disk at the time of factory shipments is a premise.

The product does not judge whether they are inferior goods at the time of service.

Eject

A disk is ejected.

Mode Change

If the MASTER TEMPO button is pushed into player operation mode, MASTER TEMPO LED will light up, and it will shift to the below-mentioned "test operation mode."

◆ Test operation mode command

Servo operation is sinely controllable gradually.

Keep in mind a test operation mode command that it may give a gamage to a player sa mistaking the usage.

Servo All Off

When serbo is ON, all serbo will be turned off if the TIME button is pushed.

LD On/Off

If the TEMPO button is pushed, On and Off of LD will change.

Focus On

If the RELOOP button is pushed when having stopped, LD will be turned on and an auto focus will be performed.

Spindle Kick, Tracking On/Off

If the LOOP IN button is pushed into tracking serbo OFF, a spindle kick is performed and automatic adjustment processing and tracking serbo are turned on. Moreover, tracking serbo is turned off if it pushes into tracking serbo ON.

Tracking Off

Tracking serbo is turned off if the LOOP OUT button is pushed into tracking serbo ON.

Slide FWD

If the SEARCH FWD button is pushed into tracking serbo ON, tracking serbo will be turned off and a slider will be moved in the FWD direction about 2mm.

Slide REV

If the SEARCH REV button is pushed into tracking serbo ON, tracking serbo will be turned off and a slider will be moved in the REV direction about 2mm.

Pickup UP/DOWN

If an TEXT button is pushed when stopped, LD will be turned on and a pickup will be moved up and down.

A focus is not made to close.

Mode Change

If the MASTER TEMPO button is pushed into "player operation mode", MASTER TEMPO LED will light up, and it will shift to the below-mentioned "test operation mode."

* When you rise at a step in test mode, please input a command in order of "Servo All Off", "Focus On", and "Spindle Kick, Tracking On."

5. Version Check mode

Mode for checking the software version of each microcomputer

• How to check the software version of the Main microcomputer

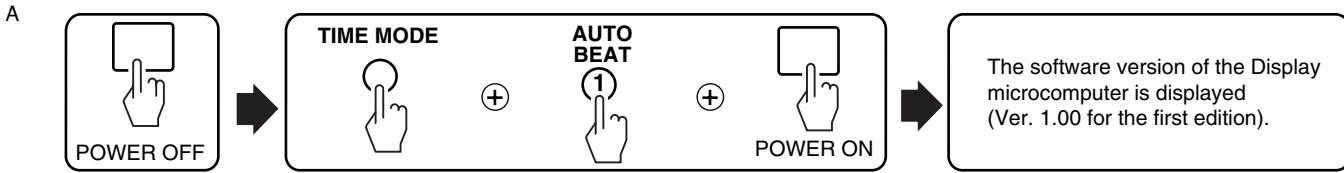

• How to check the software version of the Player microcomputer

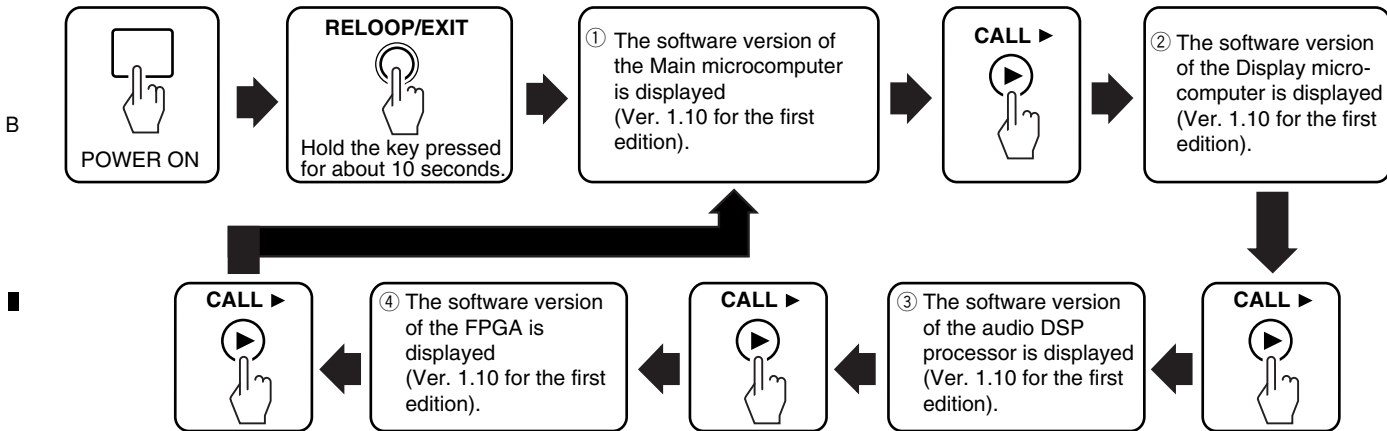

- C
- [1] Ver. 1.00 The version of the microcomputer of a player part (main microcomputer).
 - [2] disp 1.00 The version of the microcomputer of a display part.
 - [3] DSP 1.00 The version of the audio DSP.
 - [4] FPGA 1.00 The version of the FPGA.

* Audio DSP and FPGA are the processors which performs audio processing and various signal control, and operates independently with a player microcomputer. However, the program is stored in FLASH-ROM of a player microcomputer, and has structure transmitted to each processor from a player microcomputer at the time of a power supply ON.

• How to upgrade the software of the microcomputer

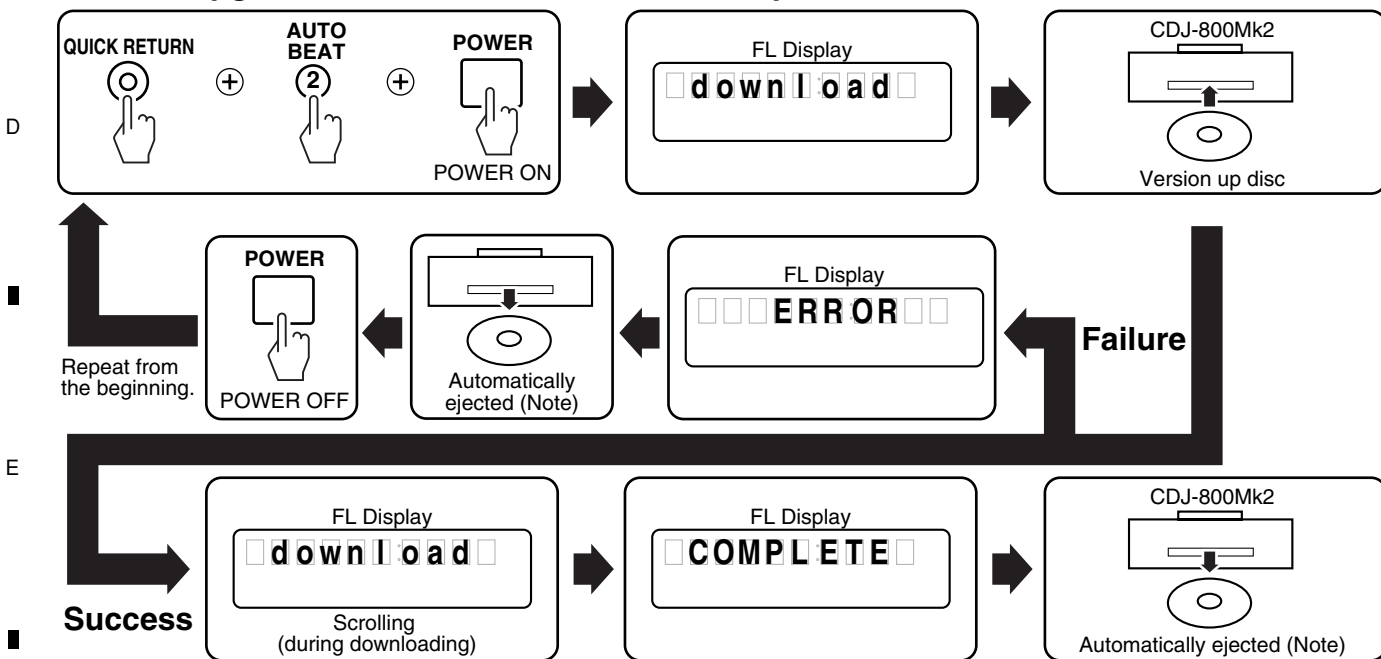

Note:

- Do NOT turn off the power after the upgrade disc is loaded till it is automatically ejected. If you do, the unit may not operate properly afterward.
- Eject a disc automatically even if updating fails.

6. Error display list / Error display mode

When it cannot operate normally in the usual use, the following error numbers are displayed on a display part. Moreover, at the time of the mode of the above-mentioned "check of the software version of a player microcomputer", if a JOG MODE button is pushed, a detailed error (E-XX which is the number of the "contents of an error" of the following table) can be checked. Whenever it pushes JOG MODE button, "a version display" and "an error display" are changed by the toggle. The error which pushed JOG MODE button and appeared first is the newest error. And the past error is displayed by pushing the CALL REV button (a push on the CALL FWD button displays the oldest error). The error is memorized to 16 pieces.

Moreover, only "E-12" and "E-15" memorize the place (TNO : MIN:SEC:FRM) which the error generated. And it can change with the TIME button. (Toggle operation)

Error number	Error name	The contents of an error
E-6002	DSP PROGRAM DOWNLOAD ERROR	A program cannot be written in DSP.
E-7201	TOC READ ERROR	26: TOC data cannot be read.
E-8301	PLAYER ERROR (Starting is unusual.)	12 : A desired address has not been searched. 15 : An address cannot be read. 22 : Focal serbo cannot be closed. 91 : A pickup does not return to an inner circumference. } (*Notes
E-8302	PLAYER ERROR (Reproduction is unusual.)	12 : A desired address has not been searched. 15 : An address cannot be read. 22 : Focal serbo cannot be closed.
E-8303	PLAYER ERROR (The writing of a buffer is unusual.)	99: The writing of a buffer is unusual.
E-8304	MP3 DECODE ERROR (The abnormalities of decoding)	Decoding is unusual.
E-8305	DATA FORMAT ERROR (The format of data is unusual.)	The format of those other than MP3
E-8709	COMMUNICATION ERROR	Communication of the microcomputer of a display part and the microcomputer of a player part cannot be performed.
E-9101	MECHANICAL TIME OUT	90: A disk loading mechanism's abnormalities (Timeout).

- * Notes : (1) Before a disk is recognized to be CD, when these errors take place, a disk is ejected automatically. Although an error number is not displayed at this time, since the contents of an error are stored in the memory, please refer to it.
(2) E-8304 and E-8305 are not memorized by the internal memory.

An error history is clearable if a power supply is switched on pushing the QUICK RETURN button and the BEAT[4] button together. At this time, a setup of AUTO CUE and TIME MODE turns into a setup at the time of factory shipments together. (AUTO CUE LEVEL=-60dB, TIME MODE=REMAIN)

- * CAUTION There is a function which carries out the memory of the CUE/LOOP point for the 800 maximum disks in this machine. If an error history is cleared, since all CUE/LOOP memories will also be cleared simultaneously, please take great care about use in this mode.

7.1.2 RESET and CLOCK MAP

CDJ-800MK2 RESET ROOT MAP

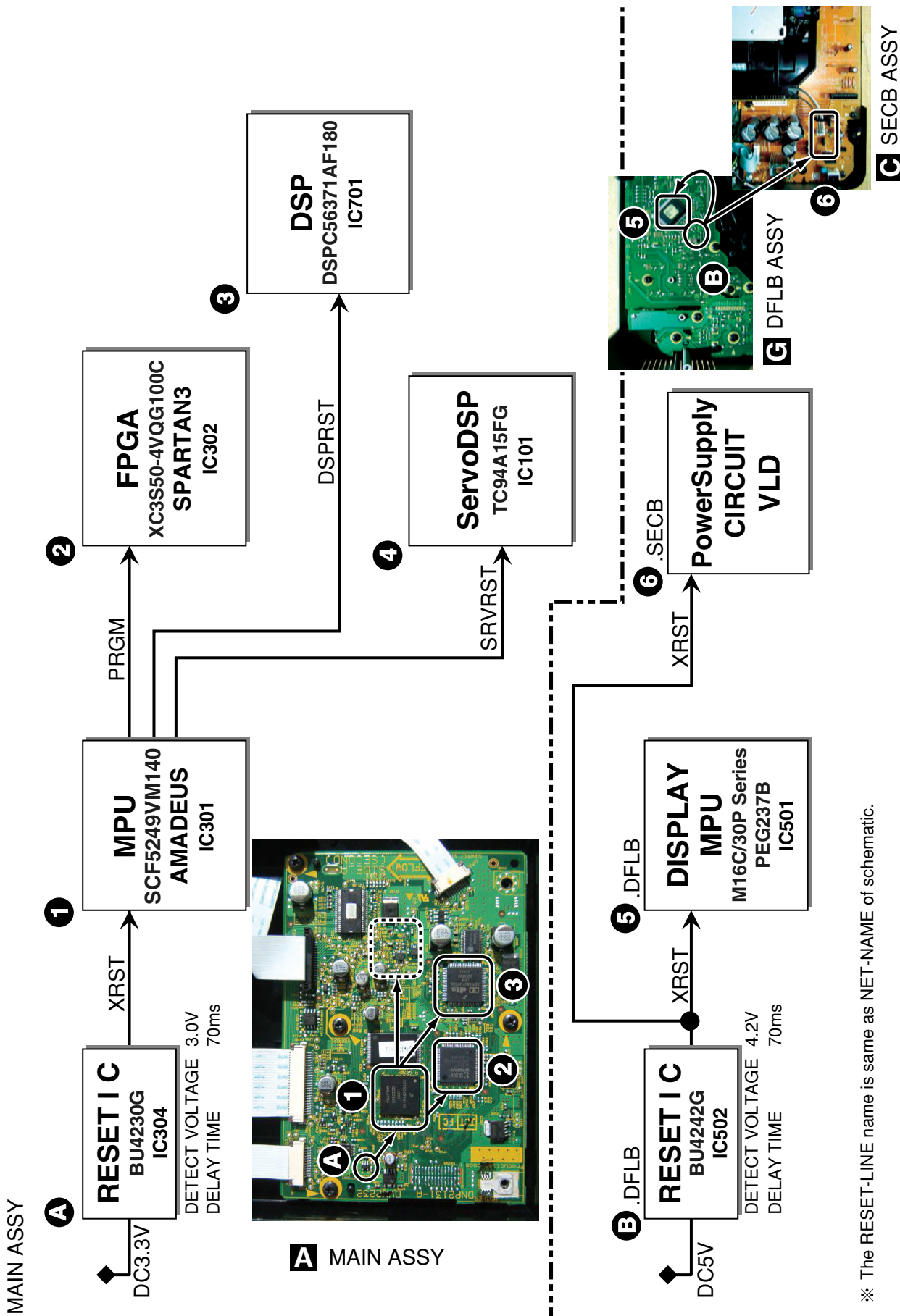

※ The RESET-LINE name is same as NET-NAME of schematic.

CDJ-800MK2 CLOCK DELIVERY MAP

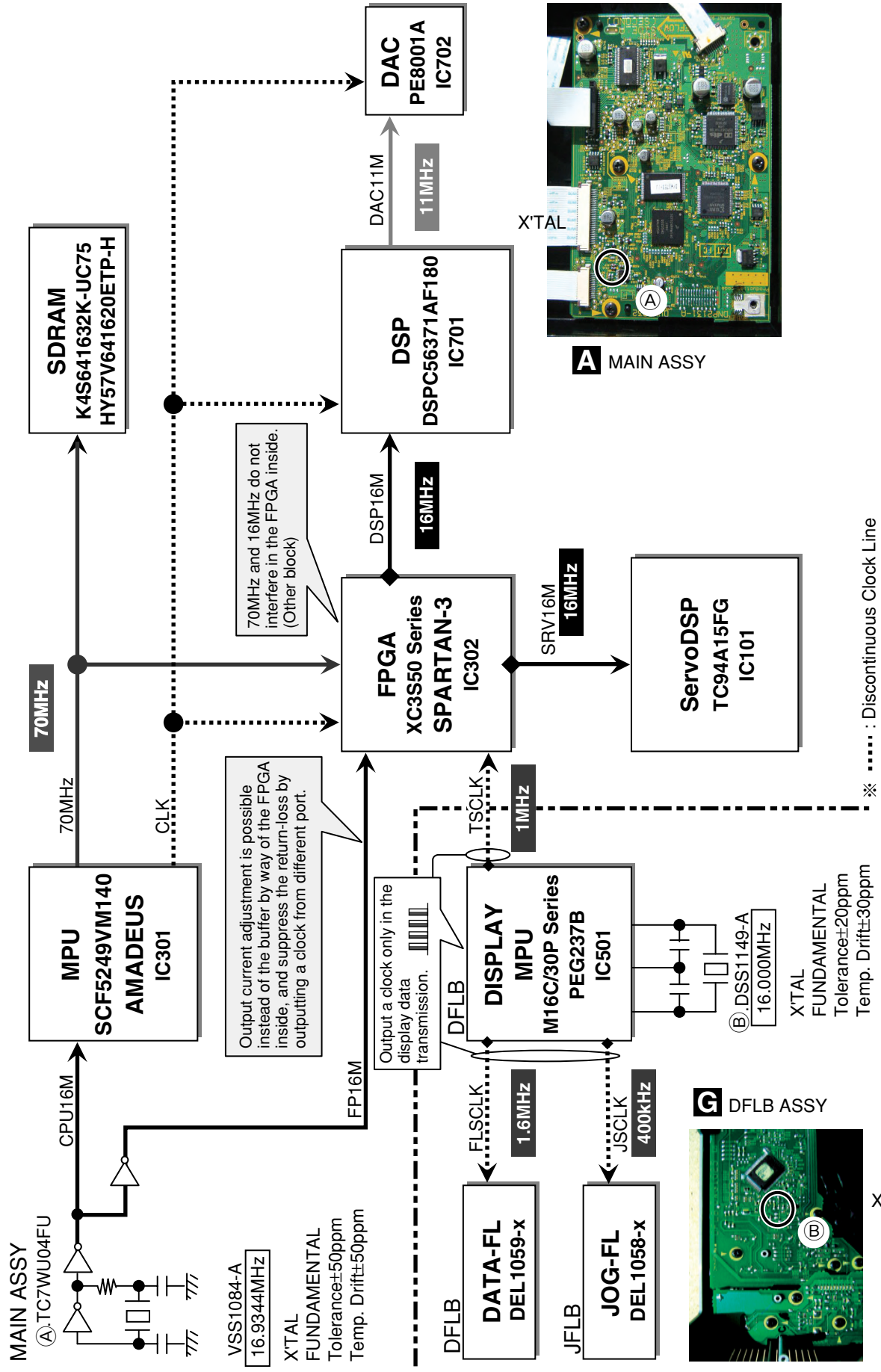

7.1.3 TROUBLE SHOOTING

Note : The numbers for the waveform photos are identical to those for the schematic diagrams and board diagrams.

Points to be checked beforehand and a note :

- When a failure judgment of the ICP (Micro Fuse) is performed using a tester, be sure to judge according to the resistance values. If a simplified measurement method, such as Short-circuit Check mode, is used for testing, a partially-damaged ICP cannot be detected.
- The ICP is very sensitive. First, check the power line to verify that the placed ICP is not damaged.
- Defective soldering of surface mount devices may have caused a problem. Check if the symptom changes when you press the corresponding surface mount device with a finger.
- For the address-bus and data-bus lines on the MAIN Assy, the dump (serial) resistance is never used.

Freeze (1/2)

Sites	Waveforms	Points to be checked	Causes & Measures to be taken	Remarks
E8709 error If the power supply is normal, this symptom is caused either by a defective core block of the MAIN Assy or a failure in communication between the DISPLAY MPU (IC501) and MAIN Assy. A defective core block means that the processes up to the FPGA (IC302) configuration have not been completed. In a case of a failure in the communication line, the core block is normal. In either case, no error indication is displayed on the control panel because the E8709 error code is sent to the DATA-FL display by the DISPLAY MPU itself.				 <p>Control panel</p>
Note: The core block comprises 4 main ICs: MPU (IC301), SDRAM (IC303), FLASH (IC300), and FPGA (IC302).				
		① Play back a CD. Check if the audio signal is output from the analog output terminal (JA801).	If the audio signal is output, the core block is OK. The cause is a failure in communication between the DISPLAY MPU and the MAIN Assy. On the contrary, if the CD cannot be played, the core block is in failure. Proceed to Step ⑤ .	
DFLB Assy SECB Assy		② Disconnect then reconnect the FFC cable between the DFLB and SECB Assys, and that between the SECB and MAIN Assys to check if the symptom is ameliorated.	If the symptom is ameliorated, loose connection of the FFC cable is the cause.	
Unit		③ Disconnect then reconnect the FFC cable between the MAIN and JACK Assys and the cable with connectors that connects the JACK and SECB Assys to check if the symptom is ameliorated. Also check for the 5 V power line, including loose connection of the connectors.	If 5 V power is not supplied to the DAC (IC702), the 3-wire serial signal level between the DAC and the MPU is lowered, because the DAC is not started, which will lead to a failure in starting of the FPGA (the loading motor rattles). Repair the 5 V power line.	
DFLB Assy SECB Assy MAIN Assy	DFLB Assy ④ to ⑦	④ Check the waveform at the points (TSCLK, TSDO, TSDI, and TSCS) designated in the waveform photo to confirm that the communication line between the DISPLAY MPU (IC301) and FPGA (IC302) is normal.	If the waveform is unstable or extremely low in level, loose connection of the output terminals or connectors on the line, chip fracture, poor power supply to IC308, or partial damage of IC308 may be the cause. Replace IC308 and check the connections.	
		⑤ 5 Deployment of the data that had been written in the flash memory (IC300) into the SRAM built into the MPU (IC301) may have failed. Check that the voltage at TP19 is 0 V.	If the waveform at TP19 continuously fluctuates, deployment of the data failed. A checksum error of the SRAM built into the MPU (IC301) was generated. Check the mounting status of IC301.	
		⑥ 6 Deployment of the program and data that had been written in the flash memory (IC300) into the SDRAM (IC303) may have failed. Check that the voltage at TP30 is 0 V.	If the waveform at TP30 continuously fluctuates, deployment of the program and data failed. A checksum error of the SDRAM (IC303) was generated. Check the mounting status of IC303.	
MAIN Assy		⑦ Check if the soldered portion of IC311 on the CLK line is lifted off the board. Note: It has been found that the cell and the part are not compatible. With the Assys of the lots before the modification, defective mounting may have occurred.	If the defective mounting of IC311 is the cause, "POWER ON" is displayed for a while, a rattle is generated from the player, then E8709 error is indicated. A disc cannot be loaded in the player.	
MAIN Assy		⑧ Check if the soldered portion of IC312 on the PRGM line is lifted off the board. Note: It has been found that the cell and the part are not compatible. With the Assys of the lots before the modification, defective mounting may have occurred.	If the defective mounting of IC312 is the cause, "POWER ON" is displayed for a while, then E8709 error is indicated. A disc cannot be loaded in the player.	
MAIN Assy SECB Assy REGB Assy		⑨ Check the power system for the core block, paying attention to the following points: (1) Is the ICP damaged?, and (2) Are cables firmly connected?	Replace the ICP or check the cable connections.	
TRNS Assy ACIN Assy		⑩ If power is not supplied to any power system, check the primary source. Inappropriate commercial power input or blown primary fuse (FU8001) or transformer fuse (T21) may be the cause.	Replace the fuses.	
MAIN Assy	MAIN Assy ⑱	⑪ Check the waveform at the RST Test Land, referring to the waveform photo, to confirm that the Reset IC (IC304) resets the MPU (IC301) properly. The Reset IC is normal if resetting is canceled about 70 msec after the power is turned on.	Abnormal delay time or an unstable waveform suggests fracture of the C303 chip. Replace the C303. If the symptom is not ameliorated, replace the IC304.	

Freeze (2/2)

Sites	Waveforms	Points to be checked	Causes & Measures to be taken	Remarks
MAIN Assy	MAIN Assy ⑦①	⑫ Check the waveform at the CPU16M Test Land, referring to the waveform photo, to confirm that the crystal oscillation circuit is operating normally.	An unstable waveform or extremely low level suggests chip fracture or partial damage of the crystal oscillator (X301). Replace the chip or X301.	
MAIN Assy	MAIN Assy ⑰⑨	⑬ Check the waveform at the designated point on the PRGM line, to confirm that the MPU (IC301) resets the FPGA (IC302) properly.	An unstable waveform suggests loose connection of the output terminal of the MPU (IC301) or chip fracture on the PRGM line. Even if the waveform at the designated point is	
MAIN Assy	MAIN Assy ⑳ to ㉔	⑭ Check the waveform at the point designated on the waveform photo, to confirm that the configuration procedures between the MPU (IC301) and FPGA (IC302) are properly performed.	An unstable waveform suggests loose connection of the output terminal or chip fracture. Even if the waveform at the designated point is normal, there may be poor contact of connectors in downstream lines. Resolder the output connectors,	



Display (1/2)

Sites	Waveforms	Points to be checked	Causes & Measures to be taken	Remarks	
Lighting of the LEDs and indications and the FL display on the control panel do not function. If the power supply is normal, this symptom is caused by a defective DISPLAY MPU (IC501,) which controls the display on the control panel, including the FL indication and lighting of the LEDs. (If the DISPLAY MPU is normal, the indications of internal data on the DISPLAY MPU, such as POWERON and E-8709, will be displayed on the DATA-FL display.) To confirm that the core block of the MAIN Assy is normal, play back a CD without using the control panel and check the audio output.					
DFLB Assy SECB Assy REGB Assy		① Check the power to be supplied to the control panel, paying attention to the following points: (1) Is the ICP damaged?, and (2) Are cables firmly connected?	Replace the ICP or check the cable connections.		
TRNS Assy ACIN Assy		② If power is not supplied to any power system, check the primary source. Inappropriate commercial power input or blown primary fuse (FU8001) or glass fuse (T21) are possible.	Replace the fuses.		
DFLB Assy	DFLB Assy ④⑨	③ Check the waveform of the XRST line, referring to the waveform photo, to confirm that the Reset IC (IC502) resets the DISPLAY MPU (IC501) properly. The Reset IC is normal if resetting is canceled about 70 msec after the power is turned on.	Abnormal delay time or an unstable waveform suggests fracture of the C507 chip. Replace the C507. If the symptom is not ameliorated, replace the IC502.		
DFLB Assy	DFLB Assy ⑦②	④ Check the waveform at Pin 12 of IC501, referring to the waveform photo, to confirm that the crystal oscillation circuit is operating normally.	An unstable waveform or extremely low level suggests chip fracture or partial damage of the crystal oscillator (X501). Replace the chip or X501.		
No indication only on the DATA-FL display If the power supply is normal, this symptom can be caused only by a failure in the DATA-FL (V501) or the communication between the DATA-FL and DISPLAY MPU (IC501).					
		① Enter Display Check mode of Service mode and check if other keys on the control panel function and if the LEDs light.	If the LEDs and JOG-FL (V601) do not light, nor does the DATA-FL (V501) display, the DISPLAY MPU that controls those will not function properly. See "Lighting		
ACIN Assy		② Check the setting of the voltage selector switch (on the rear panel). (for RLF model)	Set the switch to the position that corresponds to the commercial power source.		
DFLB Assy SECB Assy TRNS Assy		③ Check the Vload voltage (VLD, VLDD). If the voltage measured at the periphery of the power terminal of the DATA-FL (V501) is 29.3 V DC or more, it is OK.	If the voltage is 0 V, the ICPs (IC25, IC58, and IC59) are fried. Replace the ICPs.		
DFLB Assy	DFLB Assy ⑦④	④ Check the FLAC voltage (FLAC1, FLAC2). If the voltage measured at the both ends of the DATA-FL (V501) lead is 4 V AC or more, it is OK.	If the AC current waveform does not appear, check the connection between the Assys.		
DFLB Assy		⑤ Check the waveform at Pin 46 of DATA-FL (V501), to confirm that 5 V power is supplied to the built-in driver.	If the 5 V power is not supplied, soldering touchup is needed.		
DFLB Assy	DFLB Assy ⑤④ to ⑤⑦	⑥ Check the points designated in the waveform photo to confirm that the procedures of the communication between the DISPLAY MPU (IC501) and the DATA-FL (V501) are normal.	A solder fracture of the DATA-FL terminal or loose connection of the terminals on the communication line between the DISPLAY MPU and the DATA-FL is suspected. Soldering touchup is needed. If the symptom is not ameliorated after soldering touchup, replace the DATA-FL.		

Display (2/2)

Sites	Waveforms	Points to be checked	Causes & Measures to be taken	Remarks
No indication only on the JOG-FL display				
If the power supply is normal, this symptom can be caused only by a failure in the JOG-FL (V601) or the communication between the JOG-FL and the DISPLAY MPU (IC501).				
		① Enter Display Check mode of Service mode and check if other keys on the control panel function and if the LEDs light.	If the LEDs and DATA-FL (V501) do not light, nor does the JOG-FL (V601) display, the DISPLAY MPU that controls those will not function properly. See "Lighting of the LEDs and indications and the FL display on the control panel do not function."	
ACIN Assy		② Check the setting of the voltage selector switch (on the rear panel). (for RLF model)	Set the switch to the position that corresponds to the commercial power source.	
JFLB Assy DFLB Assy SECB Assy TRNS Assy		③ Check the Vload voltage (VLD, VLDD, VLDJ). If the voltage measured at the periphery of the power terminal of the JOG-FL (V601) is 27.8 V DC or more, it is OK.	If the voltage is 0 V, the ICPs (IC25, IC58, IC59, and IC603) are fried. Replace the ICPs.	
JFLB Assy		④ Check the FLAC voltage (FLAC3, FLAC4). If the voltage measured at the both ends of the JOG-FL (V601) lead is 2.6 V AC or more, it is OK.	If the AC current waveform does not appear, check the connection between the Assys.	
JFLB Assy		⑤ Check the waveform at Pin 23 of JOG-FL (V601), to confirm that 5 V power is supplied to the built-in driver.	If the 5 V power is not supplied, soldering touchup is needed.	
JFLB Assy	JFLB Assy ⑥0 to ⑥3	⑥ Check the points designated in the waveform photo to confirm that the procedures of the communication between the DISPLAY MPU (IC501) and the JOG-FL (V601) are normal.	A solder fracture of the JOG-FL terminal or loose connection of the terminals on the communication line between the DISPLAY MPU and the JOG-FL is suspected. Soldering touchup is needed. If the symptom is not ameliorated after soldering touchup, replace the JOG-FL.	
No indication on either the DATA-FL nor JOG-FL displays				
This symptom occurs when the Vload voltage, to be supplied to both the DATA-FL (V501) and JOG-FL (V601), is not supplied.				
JFLB Assy DFLB Assy		① Check if the Vload voltage (VLD, VLDD, VLDJ) is supplied.	If the voltage is 0 V, the ICPs on the line are fried. Replace the ICPs.	
SECB Assy		② Check if the Vload power circuit is reset canceled. Check if the voltage at Pin 9 of CN56 becomes high after the power is turned on.	Resetting of this circuit is performed by the Reset circuit (IC502) mounted on the DLFB Assy. Resetting is done simultaneously with the DISPLAY MPU (IC501). As only the FL display has a problem, Pin 9 of CN501 on the DFLB Assy is in failure.	
Part of the FL display does not light, frequently flickers, or is dark.				
DFLB Assy JFLB Assy		① Visually check if the symptom occurs constantly in the same area.	If the symptom occurs constantly in the same area, the FL display is defective.	
JFLB Assy DFLB Assy SECB Assy TRNS Assy		② If the symptom does not occur in the same area, check the waveform of the Vload voltage, FLAC voltage and 5 V power, to confirm that the supply is stable. (See Steps ③, ⑤, and ⑥ in "No indication only on the DATA (or JOG)-FL display.")	If the supply is unstable, soldering touchup is needed. If the symptom persists, replace the part.	
Black dots or stains appear on some parts of the FL display after Display Check mode of Service mode is entered.				
			Impurities in the FL tube are the cause. For amelioration, replace the DATA-FL or JOG-FL.	

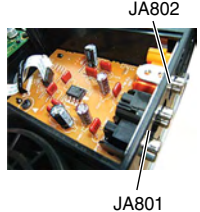
Audio output

Sites	Waveforms	Points to be checked	Causes & Measures to be taken	Remarks
No audio signal is output. If a signal waveform is normally output from the digital output terminal (JA802), the AUDIO DSP (IC701) is judged to be normal. In such a case, the problem exists at the subsequent stages of the AUDIO DSP output. During CD playback, first check the analog output terminal (JA801) then the previous stages. Be sure to carefully check for solder fractures at the phono plug.				
JACK Assy		① Check the waveform of the audio output signal at the analog output terminal (JA801). Check if the audio signal is not output from L and R channels, or only from one channel.		
JACK Assy		② Check if the digital audio signal is output from the digital output terminal (JA802).	If the digital audio signal is also not output, the AUDIO DSP (IC701) Assy is defective. See Step ④ in "No digital output."	
JACK Assy	JACK Assy ④⑩	③ Check the waveform at the L4 and R4 Test Lands near analog output terminal (JA801).	If the audio signal is output from those points, a solder fracture of the phono plug or chip fracture on the audio line is suspected. Soldering touchup is needed.	
JACK Assy SECB Assy		④ Check if 8 V and -7 V power are supplied to the OP AMP (IC801).	If the power is not supplied, check the cable connection of the power line.	
JACK Assy		⑤ Check the waveform at the L1 and R1 Test Lands on the OP AMP (IC801).		
MAIN Assy	MAIN Assy ④⑤	⑥ Check the waveform at the Lch and Rch Test Lands near C705/C706.	If the audio signal is output at the point, audio muting may remain activated. During CD playback, check if the logical state of the signal at Pin 4 of CN801 is low.	
MAIN Assy		⑦ Check if 5 V power is supplied to the DAC (IC702).	If the power is not supplied, check the cable connection of the power line.	
MAIN Assy	MAIN Assy ④⑤	⑧ Check the waveform at the 11M Test Land, referring to the waveform photo, to confirm that the clock input to the DAC (IC702) is normal.	An unstable waveform or extremely low level suggests loose connection of the clock terminal on the AUDIO DSP.	
MAIN Assy	MAIN Assy ④① to ④③	⑨ Check the points (DACLRCK, DACDATA, DACBCK) designated in the waveform photo to confirm if the procedures of the communication between the DAC (IC702) and AUDIO DSP (IC701) are normal.	An unstable waveform suggests loose connection output terminals on the AUDIO DSP or chip fracture on the line.	
Audio performance is poor. As grounding to the chassis is poor with this model, audio performance is largely affected if the specify screws are not tightened with the standard torque.				
		① Check if the screw that secures the bottom plate and is located near the plug is a screw with a projection (BBT).	Replace with a BBT screw if the original screw is not BBT.	
		② Check if the two screws that secure the bottom plate, including the above-mentioned screw with a projection, are firmly secured.	If the screws are loosely tightened, retighten the screws with the standard torque.	
Poor S/N ratio at the intervals of no sound, such as between musical pieces The S/N ratio is poor at the intervals of no sound, such as between musical pieces and at the time of power on, because audio muting is not activated. Possible causes are zero-data detection signals not output from the DAC (IC702) or a defective audio muting circuit. The following checks must be performed during CD playback.				
MAIN Assy	MAIN Assy ④④	① Check the waveform at the terminal (Pin 21) for zero-data detection on the DAC (IC702). If the level is low between musical pieces and at the time of power on and high during CD playback, the terminal is normal.	If inversion of the logical state of signals is not performed, loose connection of Pin 21 on the DAC is most likely. Soldering touchup is needed.	
MAIN Assy	MAIN Assy ④⑤	② Check the waveform at Pin 6 of CN701. If the level is high between musical pieces and at the time of power on and low during CD playback, the terminal is normal.	If audio muting remains deactivated, check chip fracture on the line or cable connection.	

Digital output

Sites	Waveforms	Points to be checked	Causes & Measures to be taken	Remarks
No digital output				
First, check if neither analog nor digital signals are output. If neither is output, the AUDIO DSP (IC701) is in failure. During CD playback, first check the digital output terminal (JA802) then the previous stages. Be sure to carefully check for solder fractures at the digital output terminal.				
JACK Assy		① Check the waveform of the digital audio signal at the digital output terminal (JA802).		
JACK Assy		② Check if the analog audio signal is output from the analog output terminal (JA801).	If neither digital nor analog audio signal is output, the AUDIO DSP (IC701) does not function properly. Proceed to Step ④.	
MAIN Assy	MAIN Assy ⑦⑩	③ Check the waveform at the point designated.	No signal suggests lifted soldered portion of the AUDIO DSP (Pin 69 of IC701) or chip fracture on the line. If there is a signal output, poor cable connection, loose connection of the connectors, or solder fracture of the phono plug is suspected.	
MAIN Assy	MAIN Assy ⑳	④ Check the waveform at the DSP16M Test Land, to confirm that the 16 MHz clock signal is supplied from the MPU (IC301) via the FPGA (IC302).		
MAIN Assy	MAIN Assy ㉑, ㉒, ㉓, ㉔, ㉕	⑤ Check the waveform at the point designated, to confirm that the configuration procedures between the MPU (IC301) and the AUDIO DSP (IC701) are properly performed.	An unstable waveform suggests loose connection of the output terminal or chip fracture.	

Player (1/4)

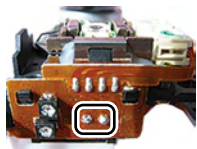
Sites	Waveforms	Points to be checked	Causes & Measures to be taken	Remarks
No disc playback.				
A disc is ejected immediately after it is loaded. (without an error code)				
RLYB Assy		① Visually check if the LD short-circuit switch (S1101) remains closed.	Set the LD short-circuit switch to OPEN.	 LD short-circuit switch
Player		② Check if the slot-in mechanism SV Assy is securely hooked to the player unit.	Firmly secure the Assy with the four hooks.	
Pickup Assy		③ Visually check if solder is short-circuited at the LD short-circuit Land on the Pickup Assy.		 LD short-circuit land
Unit		④ Check if the FFC cables between the pickup and the RLYB Assy and the RLYB and MAIN Assys are improperly connected, if the conductor side is defective, and if there is poor contact, such as cable disconnection. Also check for loose connection of connectors.	If the symptom is ameliorated by replacement of the FFC cable, the defective cable is the cause.	
MAIN Assy		⑤ Check the voltage of each section on the MAIN Assy.		
MAIN Assy		⑥ Replace the MAIN Assy.		
A disc cannot be loaded.				
Unit		① Check if the FFC cables between the pickup and the RLYB Assy and the RLYB and MAIN Assys are improperly connected, if the conductor side is defective, and if there is poor contact, such as cable disconnection. Also check for loose connection of connectors.	If the symptom is ameliorated by replacement of the FFC cable, the defective cable is the cause.	
MAIN Assy		② Check the voltage of each section on the MAIN Assy.		
MAIN Assy		③ Replace the MAIN Assy.		

Player (2/4)

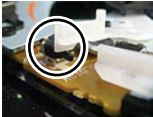
Sites	Waveforms	Points to be checked	Causes & Measures to be taken	Remarks
<p>Loading-in attempts are repeated although no CD is loaded. (On the DATA-FL display, the indications "NO-DISC" and "EJECT" are alternately displayed.) A CD cannot be loaded. A failure in the detection system of the slot-in mechanism SV Assy is most likely the cause. The detection switch detects a trigger signal for operation start or stop of the loading motor. The present symptom may be caused by the disability of detection of a trigger signal for operation start.</p>				
SLMB Assy		<p>❶ Visually check if the loading detection switch (S1902) is kept pressed by the switch lever (white) as the lever overrides the switch.</p>	Disengage the switch lever from the loading detection switch (S1902). If the detection switch is not closely seated on the board, soldering touchup is needed.	
MAIN Assy	MAIN Assy ③, ④	<p>❷ Check the SW signal at the LPS2 and LPS1 Test Lands at the time of CD loading, referring to the waveform photo. Does the SW signal change from L to H? Especially pay attention to a change at LPS2.</p>	Repeated loading-in attempts may be caused by short-circuiting of the line to ground. Disabled CD loading may be caused by a solder fracture at the loading detection switch (S1902), soldered portion lifted off the board of the surface mount part on the line, or loose connection of the FFC cables.	
MAIN Assy	MAIN Assy ⑤	<p>❸ By observing the waveform at the PWMLO Test Land, check that the duty at PWMLO changes, as indicated in the waveform photo:</p> <ul style="list-style-type: none"> • During stop: Duty 50 % • During loading-in: Duty 0 % • During loading-out: Duty changes from 100 %, 25 %, then to 75 %. 		
MAIN Assy		<p>❹ Check the voltage at the MPU (IC301), FPGA (IC302), IC105 (TC7W04), and the driver IC (IC102).</p>		
<p>No ejection. Abnormal noise generated after a CD is loaded A failure in the detection system of the slot-in mechanism SV Assy is most likely the cause. The detection switch detects a trigger signal for operation start or stop of the loading motor. The present symptom may be caused by the disability of detection of a trigger signal for operation stop.</p>				
MAIN Assy	MAIN Assy ③, ④	<p>❶ Check the SW signal at the LPS1 and LPS2 Test Lands at the time of CD loading, referring to the waveform photo. Does the SW signal change from L to H? Especially pay attention to a change at LPS2.</p>	This symptom may be caused by short-circuiting of the line to ground. It may also be caused by a solder fracture at the loading detection switch (S1901), soldered portion lifted off the board of the surface mount part on the line, or loose connection of the FFC cables.	
MAIN Assy	MAIN Assy ⑤	<p>❷ By observing the waveform at the PWMLO Test Land, check that the duty at PWMLO changes, as indicated in the waveform photo:</p> <ul style="list-style-type: none"> • During stop: Duty 50 % • During loading-in: Duty 0 % • During loading-out: Duty changes from 100 %, 25 %, then to 75 %. 		
MAIN Assy		<p>❸ Check the voltage at the MPU (IC301), FPGA (IC302), IC105 (TC7W04), and the driver IC (IC102).</p>		

Player (3/4)

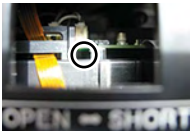
Sites	Waveforms	Points to be checked	Causes & Measures to be taken	Remarks
The error rate measured in Test Operation mode of Service mode is high.				
		① To which the cause is attributed, disc or player, must be judged first. Visually check the disc for stains on the recording surface.	If the disc is clearly stained, replace it with a clean CD.	
		② Using the disc that produced a high error rate, measure an error rate at addresses in a different area.	If the error rate at addresses in a different area is not high, the CD is defective. Replace it with a high-quality CD. If the error rates at addresses in different areas on the whole disc are high, proceed to Step ③.	
Pickup Assy		③ Check if shavings or dirt are attached to the pickup lens.	Clean the lens.	
Player		④ Check if the TM Assy (servo mechanism) is securely attached.		
Player		⑤ Check if the loading mechanism SV Assy is securely attached.		
Pickup Assy		⑥ Check if any foreign object is on the spindle table.	Remove the foreign object.	
Pickup Assy		⑦ Check if any foreign object is attached to the magnet section of the Pickup Assy.	Remove the foreign object.	
Player	MAIN Assy ①, ②, ⑧, ⑩	⑧ Check the S-curve, TE, RFO, and AGCRF levels in Service mode.	See "Failure judgment of the Pickup Assy" for details.	
The LD is not turned on after entering Test Operation mode of Service mode.				
RLYB Assy		① Visually check if the LD short-circuit switch (S1101) remains closed.	Set the LD short-circuit switch to OPEN.	 LD short-circuit switch
MAIN Assy		② Check that Pins 41 and 42 on the Servo DSP (IC101) are open or short-circuited.		
Player		③ Check if the FFC cable that connects the Pickup and the RLYB Assys is securely connected to the Pickup Assy, if the conductor side is defective, and if there is any cable breakage. Also check for loose connection of connectors.	If the symptom is ameliorated by replacement of the FFC cable, the defective cable is the cause.	
MAIN Assy		④ Check if the R101 to R105 or Q105 are missing.		
MAIN Assy		⑤ Check if the FFC cable that connects the RLYB and MAIN Assys is firmly connected to CN101.		
The pickup lens does not move up or down after entering Test Operation mode of Service mode.				
Player		① Check if the FFC cable that connects the TM and the RLYB Assy is securely connected to the Pickup Assy, if the conductor side is defective, or if there is any cable breakage. Also check for loose connection of connectors.	If the symptom is ameliorated by replacement of the FFC cable, the defective cable is the cause.	
Pickup Assy		② Check if the resistance of the focus coil is too large or if the focus coil is broken, using Service mode.	See "Failure judgment of the Pickup Assy" for details.	
MAIN Assy		③ Check if the 7 V power is supplied to Pin 32 of IC102.		
MAIN Assy	MAIN Assy ⑨	④ Check if the signal output from the FOO terminal on the MAIN Assy oscillates centered around 1.65 V.		

Player (4/4)

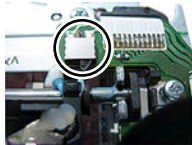
Sites	Waveforms	Points to be checked	Causes & Measures to be taken	Remarks
The spindle motor does not rotate after entering Test Operation mode of Service mode.				
MAIN Assy		① Check if the FFC cable that connects the TM and MAIN Assys is securely connected to CN102, if the conductor side is defective, or if there is any cable breakage. Also check for loose connection of connectors.	If the symptom is ameliorated by replacement of the FFC cable, the defective cable is the cause.	
Player		② Check if the Loading Mechanism Assy operates normally. (Check if there is a clamping error or scratching noise of the disc.)		
MAIN Assy		③ Check if 7 V power is supplied to R121 to R126 on the MAIN Assy.		
MAIN Assy	MAIN Assy ⑫	④ Check if the PWM waveform that oscillates centered around 1.65 V can be observed for the DMO Test Land on the MAIN Assy.		
The slider does not move after entering Test Operation mode of Service mode.				
RLYB Assy		① Check if the FFC cable (stepper flexible cable) is connected to CN1104 on the RLYB Assy.		 <p>Inside switch</p>
MAIN Assy		② Because the slider does not move until the Inside signal is recognized, check if the FFC cable that connects the TM and MAIN Assys is securely connected to CN102, if the conductor side is defective, and if there is any cable breakage. Also check for loose connection of connectors.	If the symptom is ameliorated by replacement of the FFC cable, the defective cable is the cause.	
MAIN Assy		③ Check if the signal at Pin 1 of CN102 becomes low when the power is turned on. (Is the Inside switch damaged?)		
MAIN Assy		④ Check if power is supplied to IC102.		
MAIN Assy	MAIN Assy ⑮, ⑯	⑤ Check if a sine-wave signal is input to Pins 1 and 2 of IC102.		

User setting

Sites	Waveforms	Points to be checked	Causes & Measures to be taken	Remarks
After the power is turned off, the user settings, such as AUTO CUE and TIME MODE settings, are cleared. With this model, the CUE point, AUTO CUE, and TIME MODE settings and error logs are stored in the flash memory on the MAIN Assy as user settings. No error indication is displayed for this symptom.				
MAIN Assy		After resetting the user settings to default in Service mode, set a CUE point while a CD is being played back. After the CUE point setting, wait at least 5 seconds and turn the power off then back on. Check if the CUE point is called.	Loose connection of the FLASH IC (IC300) connector is likely. If the symptom is not ameliorated after touching up the solder with a soldering iron, replace the FLASH IC.	

Updating

Sites	Waveforms	Points to be checked	Causes & Measures to be taken	Remarks
"ERROR" is displayed on the DATA-FL display. Updating of the firmware is possible in Service mode. All errors generated during updating are indicated as "ERROR," and updating fails.				
Player		① Check if a wrong CD has been loaded.	Use the correct CD for updating.	
Player		② Check if the recording surface of the disc is stained.	Replace with a clean CD for updating.	
RLYB Assy		③ Visually check if the LD short-circuit switch (S1101) remains closed.	Set the LD short-circuit switch to OPEN.	
Pickup Assy		④ Check if shavings or dirt are attached to the pickup lens.	Clean the lens.	
MAIN Assy		⑤ After resetting the user settings to default in Service mode, set a CUE point while a CD is being played back. After the CUE point setting, wait at least 5 seconds and turn the power off then back on. Check if the CUE point is called.	Loose connection of the FLASH IC (IC300) connector is likely. If the symptom is not ameliorated after touching up the solder with a soldering iron, replace the FLASH IC.	

Error codes (1/2)

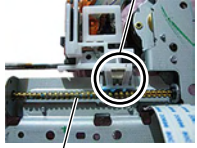
Sites	Waveforms	Points to be checked	Causes & Measures to be taken	Remarks
E-6002				
DSP PROGRAM DOWNLOAD ERROR				
At the time of initialization, the program was not downloaded (written) to the EEPROM on the AUDIO DSP. There may be a factor that hampers normal initialization of the EEPROM on the AUDIO DSP at the time of power on. The possible cause is defective state of 3-wire serial lines that are commonly used by the MPU and the FPGA, AUDIO DSP, and DACs. The data on this symptom are not stored in the internal memory.				
MAIN Assy	MAIN Assy ⑳,㉑,㉒	Check the waveforms of the 3-wire serial lines (CLK, DATA, DSPDREQ) to confirm that the configuration procedures are properly performed.	Chip fracture or soldered portion of IC lead lifted off the board on the line where the waveform does not change is most likely the cause. In the former case, replace the chip. In the latter case, soldering touchup is needed.	
E-7201				
TOC READ ERROR				
Table of Contents (TOC) data cannot be read. This symptom is associated with the reading accuracy of the servo motor of the CD player.				
Player		Measure the error rate in Player Operation mode of Service mode. To which the cause is attributed, disc or player, must be judged first. For measuring, play back the lead-in point indicated in the error code by listening the sound.	Follow the procedures described in "The error rate measured in Test Operation mode of Service mode is high."	
E-8301				
PLAYER ERROR (Startup error)				
<ul style="list-style-type: none"> E830112: The desired address could not be searched for. E830115: The address could not be read. E830122: The focus servo could not be closed. E830191: The pickup did not return toward the inner tracks. If the above-mentioned error codes are indicated before the loaded disc is recognized as a CD, the disc will be automatically ejected. This symptom is associated with the reading accuracy of the servo motor of the CD player.				
Player		① Measure the error rate in Player Operation mode of Service mode. For the error codes other than E830191, proceed to Step ②.		 <p>Joint spring</p> <p>Slider</p>
MAIN Assy	MAIN Assy ⑩	② Check the waveform at the INSIDE Test Land near CN102, by changing the positions of the Inside switch. Does the signal change between low and high according to the switch settings?	If the signal does not change, a defective Inside switch, solder fracture, soldered portion lifted off of the surface mount on the line, and loose connection of the FFC cables are likely causes.	
Player		③ Visually check if the joint spring on the TM Assy is deformed. Also check for the sliding smoothness of the slider.	If the joint spring is deformed or displaced or if the slider moves abnormally smoothly, replace the pickup.	
Player		④ Measure the error rate in Player Operation mode of Service mode. To which the cause is attributed, disc or player, must be judged first. For measuring, play back the lead-in point indicated in the error code by listening the sound.	Follow the procedures described in "The error rate measured in Test Operation mode of Service mode is high."	
E-8302				
PLAYER ERROR (Abnormality in playback)				
<ul style="list-style-type: none"> E-830212: The desired address could not be searched for. E-830215: The address could not be read. E-830222: The focus servo could not be closed. This symptom is associated with the reading accuracy of the servo motor of the CD player.				
Player		Measure the error rate in Player Operation mode of Service mode. To which the cause is attributed, disc or player, must be judged first. For measuring, play back the lead-in point indicated in the error code by listening the sound.	Follow the procedures described in "The error rate measured in Test Operation mode of Service mode is high."	

Error codes (2/2)

Sites	Waveforms	Points to be checked	Causes & Measures to be taken	Remarks
E-8303				
PLAYER ERROR (Abnormality in writing in the buffer)				
<ul style="list-style-type: none"> E830399: Abnormality in writing in the buffer <p>In theory, this error code means that buffering to the SDRAM (IC303) was impossible. However, a defective SDRAM may not be a real cause, because the unit would freeze if the SDRAM were defective. This error code is generated by factors associated with the reading accuracy of the servo motor of the CD player, such as a high error rate and subcode not read.</p>				
Player		Measure the error rate in Player Operation mode of Service mode. To which the cause is attributed, disc or player, must be judged first. For measuring, play back the lead-in point indicated in the error code by listening the sound.	Follow the procedures described in "The error rate measured in Test Operation mode of Service mode is high."	
E-8304				
MP3 DECODE ERROR (Abnormal decoding)				
<p>As this is a decoding error code for MP3 format, it is of no relevance to reading of data in CD-DA format, which does not need decoding. As the MP3 decoding process precedes the process of writing in the buffer, this error code is associated with the process that precedes the process with which E-8303 is associated. This code may also be indicated when the quality of the RF signal is deteriorated.</p>				
Player		Measure the error rate in Player Operation mode of Service mode. To which the cause is attributed, disc or player, must be judged first. For measuring, play back the lead-in point indicated in the error code by listening the sound.		
E-8305				
DATA FORMAT ERROR (Abnormal data format)				
<p>The CD is played back in a format other than MP3. Or the quality of the RF signal is deteriorated. The data on this symptom are not stored in the internal memory.</p>				
		① Check if the CD being played back is in MP3 format.		
Player		② Measure the error rate in Player Operation mode of Service mode. To which the cause is attributed, disc or player, must be judged first. For measuring, play back the lead-in point indicated in the error code by listening the sound.	Follow the procedures described in "The error rate measured in Test Operation mode of Service mode is high."	
E-8709				
COMMUNICATION ERROR				
See "E8709" error.				
E-9101				
MECHANICAL TIME OUT				
<ul style="list-style-type: none"> E910190: Abnormality in the disc-loading mechanism (timeout) 				
Player			Follow the procedures described in "The error rate measured in Test Operation mode of Service mode is high."	

FAILURE JUDGMENT OF THE Pickup Assy

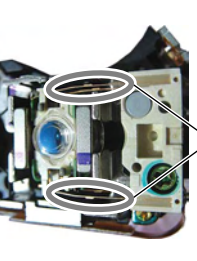
Item	Specifications	Measurement procedures	Failure judgment	Remarks
Laser Diode (LD) current Usually use a pressed CD, as the measurement result depends on the disc type.	Typ 70 mA Max 80 mA	<ol style="list-style-type: none"> ① Make sure that no CD is loaded. ② Enter Service mode. ③ During Test Operation mode, press the TEMPO button to turn the LD on. ④ Measure the voltage difference (DC value) between the Test Lands LD3S and LDCHECK on the MAIN Assy. 	If the measurement result of the LD current is 80 mA or more, the LD is deteriorated. Note: Check the mounting status of R101 to R104 (22 ohms).	To prevent damage to the LD, after the LD is turned on (Step 3 of the measurement procedures and after), never connect or disconnect the measuring equipment.
Focus coil resistance	$3.4 \pm 0.5 \Omega$	<ol style="list-style-type: none"> ① Make sure that no CD is loaded. ② Remove the bottom plate and set the LD short-circuit switch (S1101) to Short-circuiting. ③ Disconnect the FFC cable that connects the RLYB Assy and the MAIN Assy from the CN101 connector. ④ Measure the conductor resistance of the terminal assembly between Pins 13 and 14 of the FFC cable. 	If the measurement result is beyond the specified value, the pickup is in failure.	 LD short-circuit switch
Tracking coil resistance	$4.1 \pm 0.6 \Omega$	<ol style="list-style-type: none"> ① Make sure that no CD is loaded. ② Remove the bottom plate and set the LD short-circuit switch (S1101) to Short-circuiting. ③ Disconnect the FFC cable that connects the RLYB Assy and the MAIN Assy from the CN101 connector. ④ Measure the conductor resistance of the terminal assembly between Pins 15 and 16 of the FFC cable. 	If the measurement result is beyond the specified value, the pickup is in failure.	 Focus coil and Tracking coil
S-curve level Usually use a pressed CD, as the measurement result depends on the disc type.	Reference: 1.5 Vp-p	<ol style="list-style-type: none"> ① Enter Service mode. ② Load a pressed CD. (Standby) ③ During Test Operation mode, press the TIME, A, then CUE buttons to send a command. 	The pickup or the MAIN Assy is in failure if the measurement result is more than double or less than 50% of the specified (reference) value.	
Tracking Error (TE) level Usually use a pressed CD, as the measurement result depends on the disc type.	Reference: 1.1 Vp-p	<ol style="list-style-type: none"> ① Enter Service mode. ② Load a pressed CD. (Standby) ③ During Test Operation mode, press the buttons in the following order to send a command: TIME, TEMPO, RELOOP, then LOOPIN twice. ④ Measure the peak-to-peak TE waveform at the TE Test Land on the MAIN Assy. 	The pickup or the MAIN Assy is in failure if the measurement result is more than double or less than 50% of the specified (reference) value.	
RFO level Usually use a pressed CD, as the measurement result depends on the disc type.	Reference: 1.2 Vp-p	<ol style="list-style-type: none"> ① Play back a pressed CD. ② Measure the peak-to-peak RF waveform at the RFO Test Land on the MAIN Assy. 	The pickup or the MAIN Assy is in failure if the measurement result is more than double or less than 50% of the specified (reference) value.	You may disconnect the measuring equipment during measurement, if you wish.
Auto Gain Control (AGC) RF level The measurement result does not depend on the disc type.	$1.2 \text{ Vp-p} \pm 10 \%$	<ol style="list-style-type: none"> ① Play back a CD. ② During playback, measure the peak-to-peak RF waveform at the AGCRF Test Land on the MAIN Assy. 	If the RFO level is within the specified values, and if the AGC RF level is outside the range of the specified values, the MAIN Assy is in failure.	You may disconnect the measuring equipment during measurement, if you wish.

POWER ON SEQUENCE

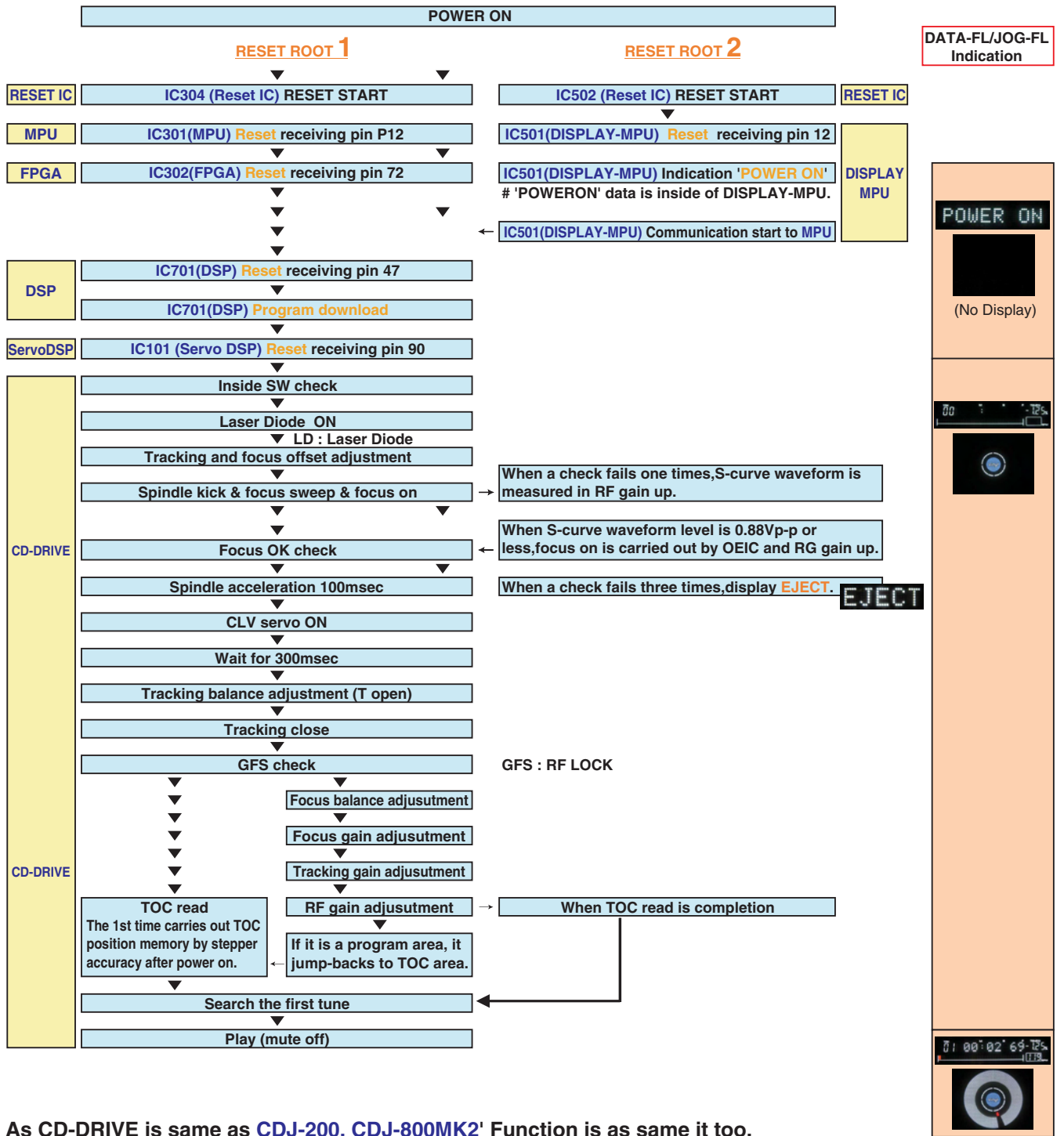

As CD-DRIVE is same as CDJ-200, CDJ-800MK2' Function is as same it too.

7.1.5 DISASSEMBLY

Note 1: Do NOT look directly into the pickup lens. The laser beam may cause eye injury.

Note 2: Even if the unit shown in the photos and illustrations in this manual may differ from your product, the procedures described here are common.

PCB Location

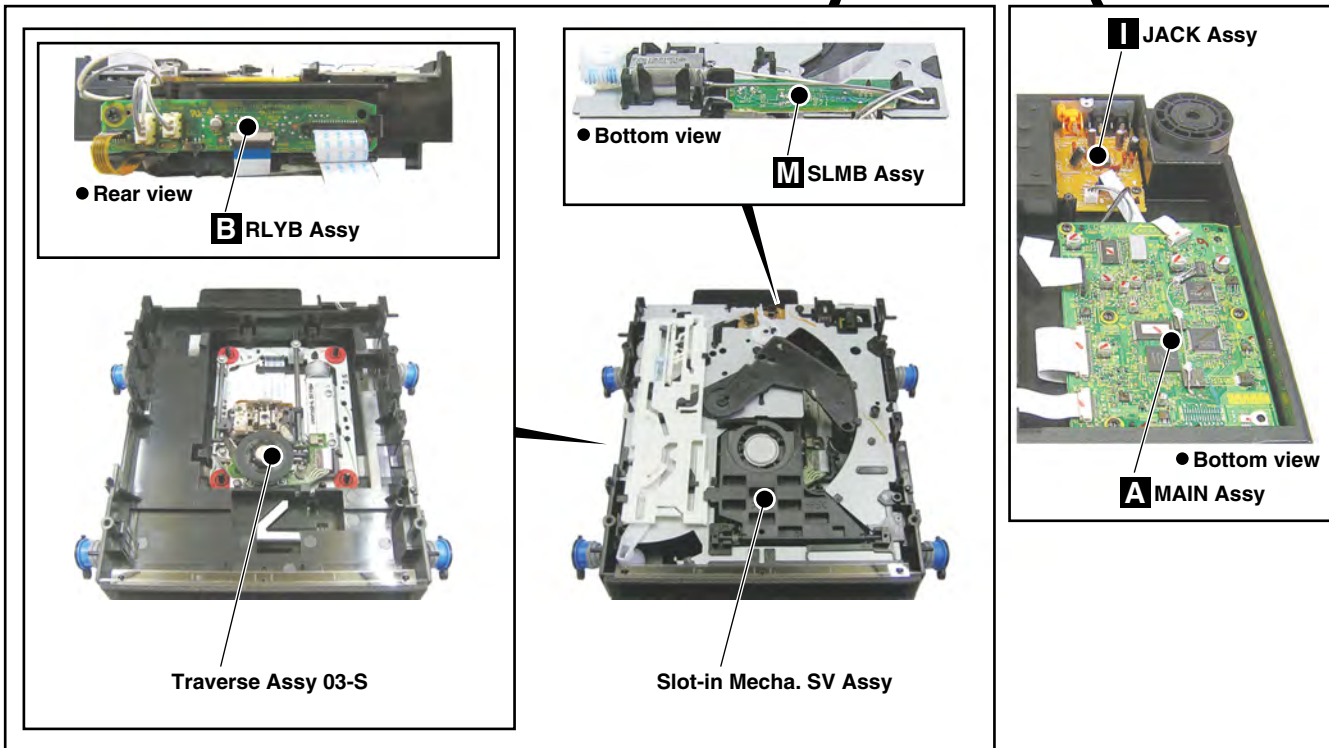
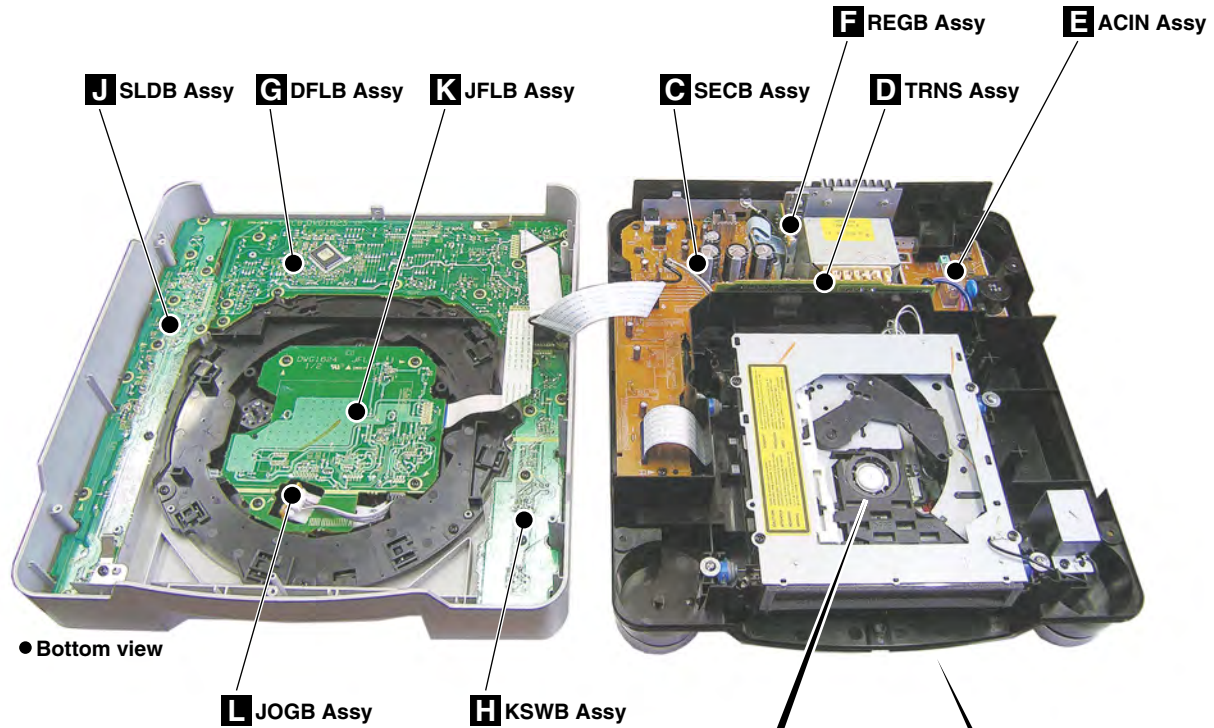

Diagnosis of MAIN Assy

Note: To work on the unit having it set upside-down, place spacers below it, as shown in the photo below, to avoid imparting stress to the sheet SW of the JOG section.

- ① Remove the one screw.
- ② Remove the five screws.
- ③ Remove the bottom plate.

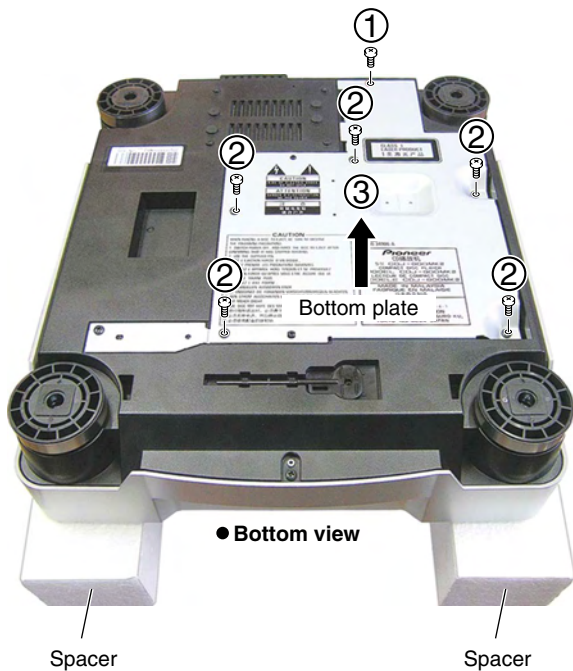

- ④ Remove the four screws.

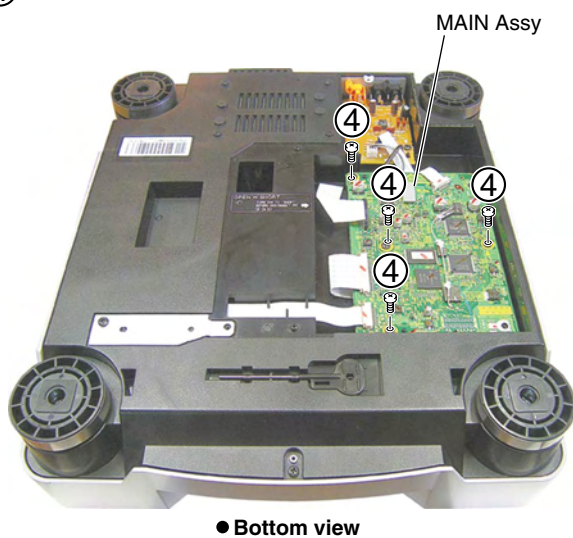

- ⑤ Stand the MAIN Assy.

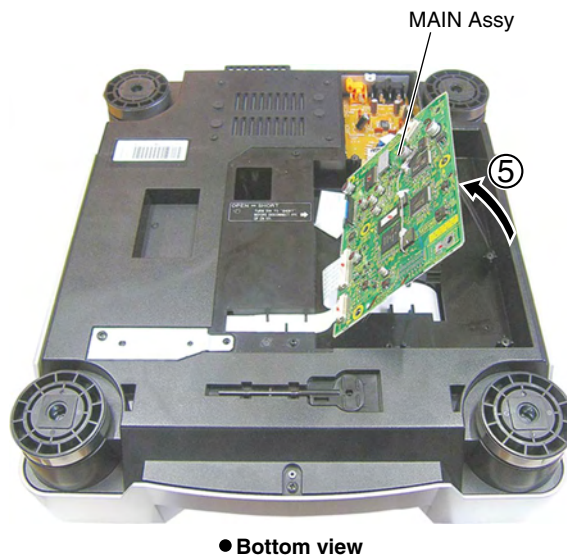

Diagnosis

A
B
C
D
E
F

Disassembly

1 Control Panel Section

① Remove the one screw.

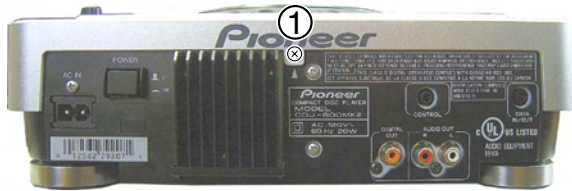

● Rear view



Note: To work on the unit having it set upside-down, place spacers below it, as shown in the photo below, to avoid imparting stress to the sheet SW of the JOG section.

② Remove the one screw.

③ Remove the five screws.

④ Remove the bottom plate.

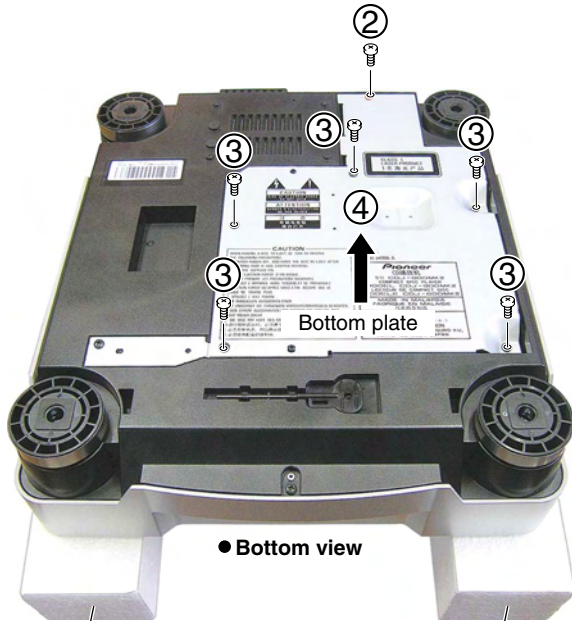

● Bottom view

Spacer

Spacer



● Short-circuit switch for the pickup

Before disconnecting the flexible cable for the pickup, change the position of the S1101 switch on the RLYB Assy to LD SHORT.

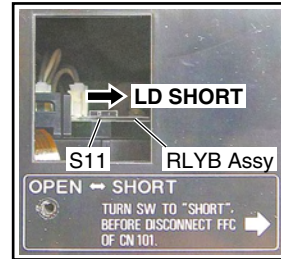

⑤ Disconnect the flexible cable for the pickup.

⑥ Disconnect the flexible cable.

⑦ Remove the five screws.

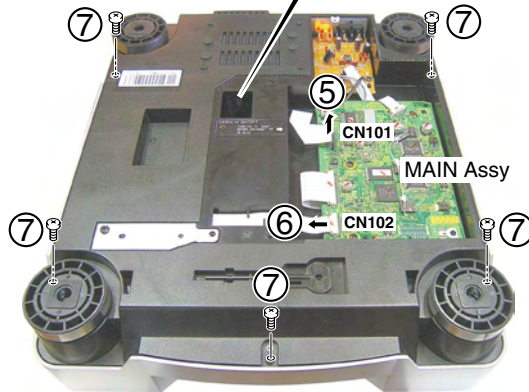

● Bottom view



⑧ Remove the control panel section.

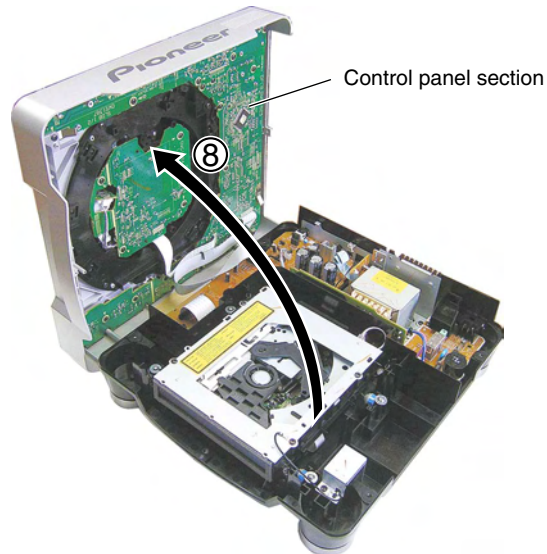

Control panel section



2 Slot-in Mecha. Section

- ① Remove the earth lead unit by removing the one screw.
- ② Remove the four DM screws.

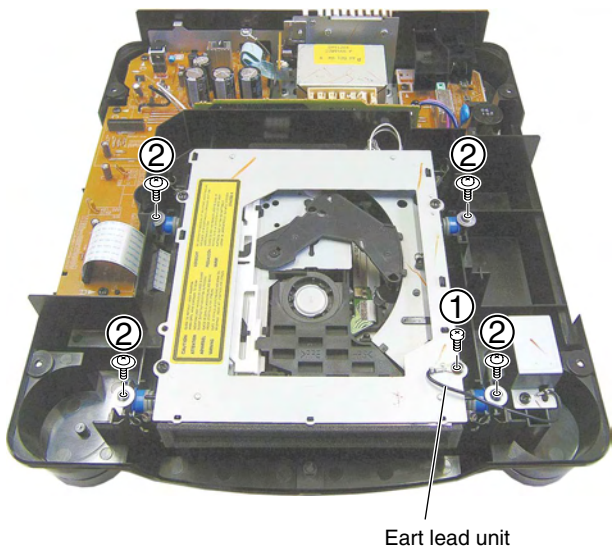

- ③ Remove the four float springs G5.
- ④ Remove the slot-in mecha. section.

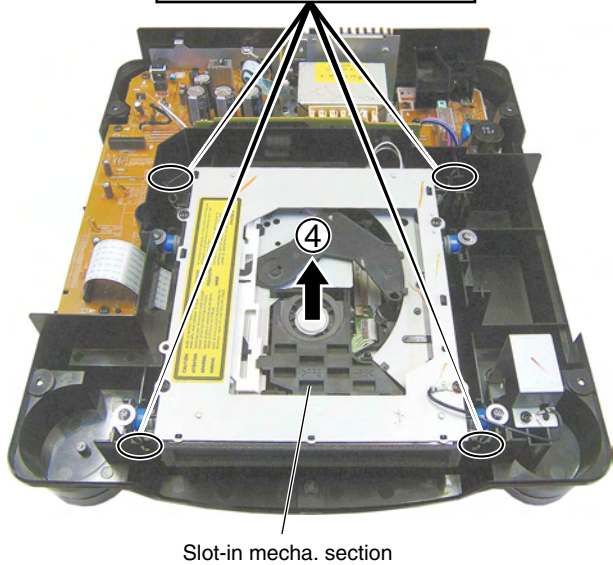
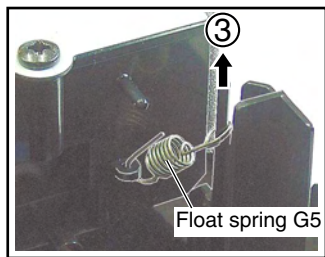

● How to handle the float spring G5

To avoid losing the float spring G5, after removing it, put it on the hook of the float base 04 Assy.

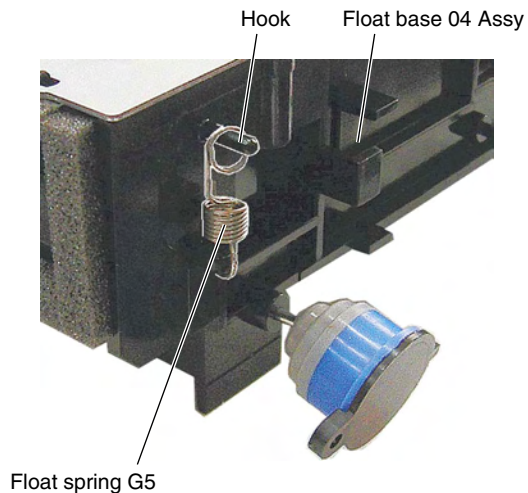

● Direction of the dampers when attaching them

When attaching the dampers, place them so that their projections (large) face front.

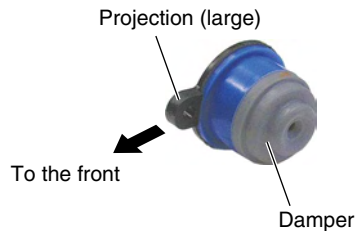

3 Slot-in Mecha. SV Assy

- ① Remove the three screws.
- ② Remove the mecha. plate.

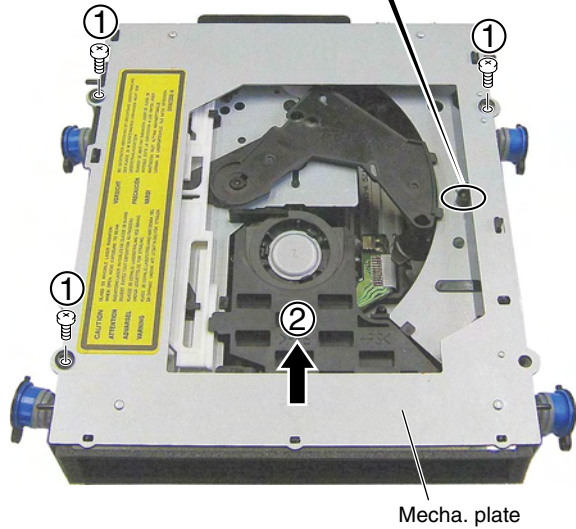

- ③ Unhook the four hooks.
- ④ Remove the slot-in mecha. SV Assy.

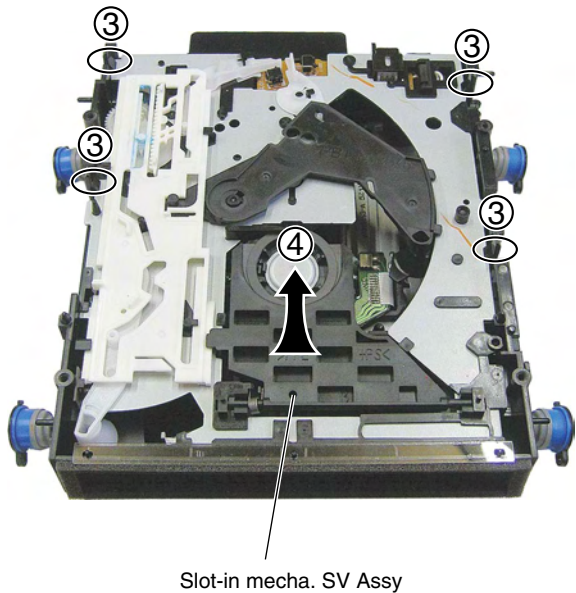

4 Traverse Assy 03-S

- ① Short-circuit two points C and D soldering.

Note: After replacement, connect the flexible cable, then remove the soldered joint (open).

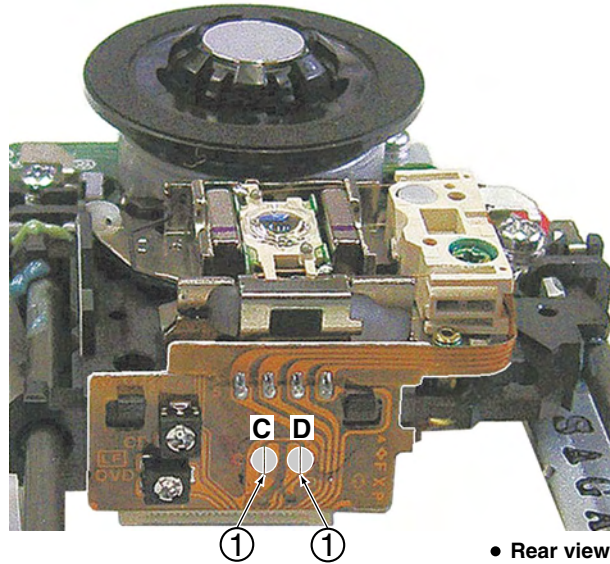

- ② Unhook the four hooks.
- ③ Disconnect cables, as required.
- ④ Remove the traverse Assy 03-S.

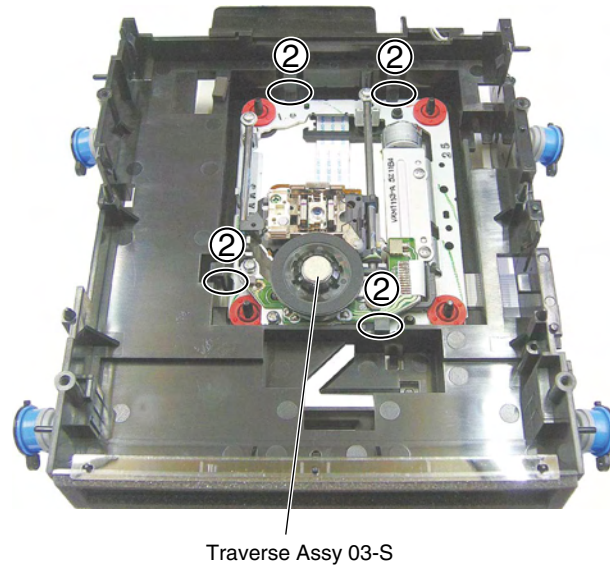

Replace



● Note on the float rubber installation

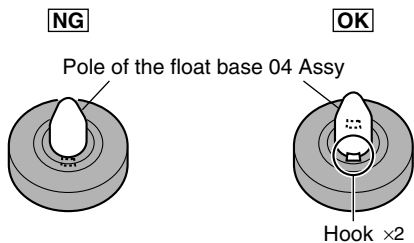

● Cleaning the pickup lens



Before shipment, be sure to clean the pickup lens, using the following cleaning materials:

- Cleaning liquid : GEM1004
- Cleaning paper : GED-008

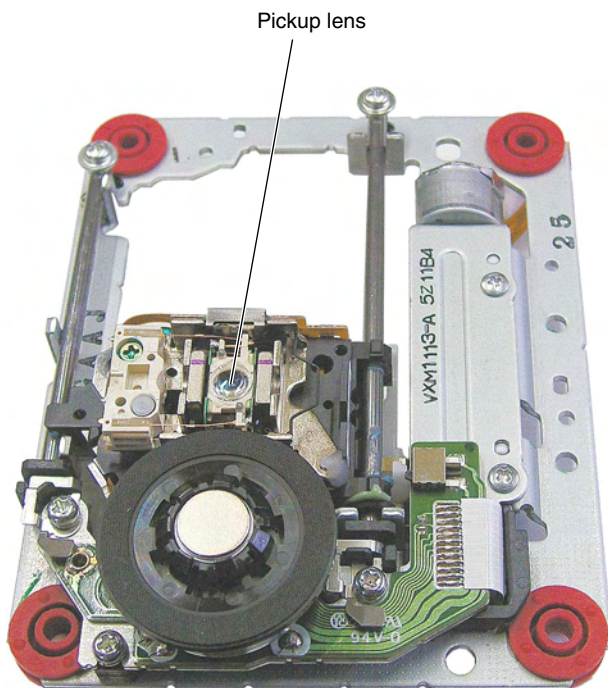

● Arrangement of the flexible cables

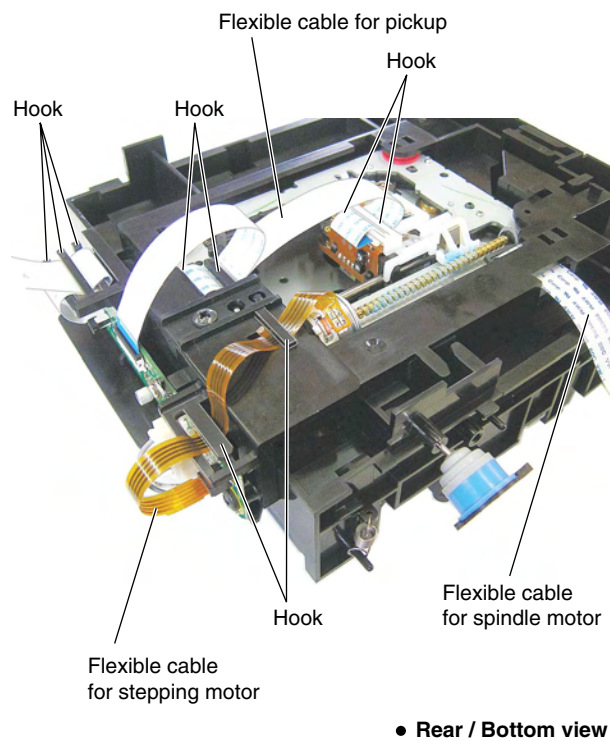
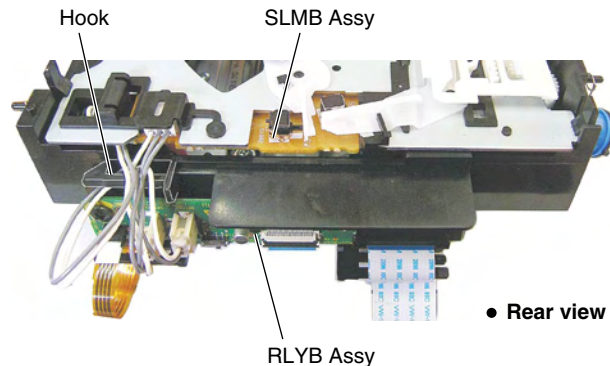

5 JOG Section

Note: To work on the unit having it set upside-down, place spacers below it, as shown in the photo below, to avoid imparting stress to the sheet SW of the JOG section.

- ① Disconnect the flexible cable.
- ② Remove the six screws.
- ③ Remove the JOG section.

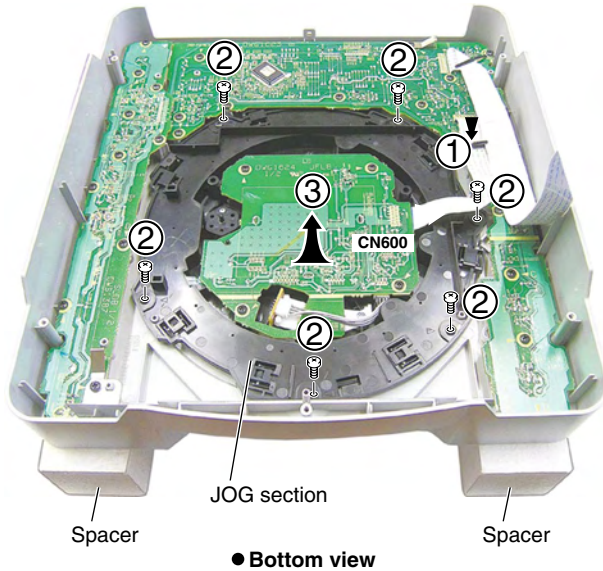

- ④ Unhook the three hooks.
- ⑤ Remove the JOG A and JOG Bs.

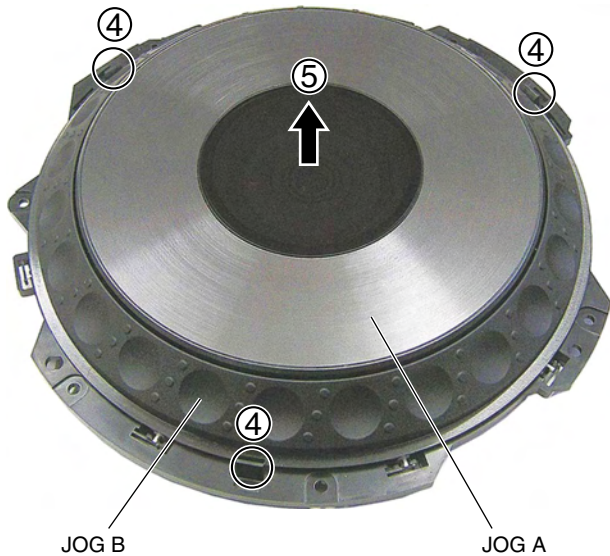

- ⑥ Remove the three screws.
- ⑦ Remove the SW ring.

Caution:
Be careful not to lost SW spring 25.

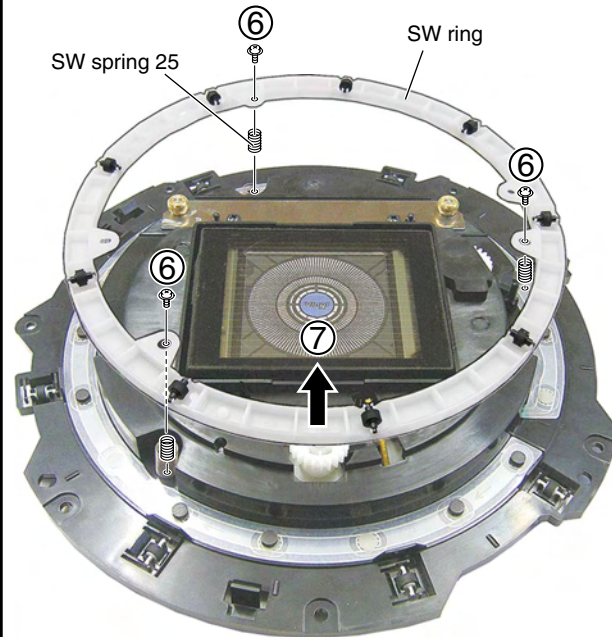

- ⑧ Disconnect the connector.
- ⑨ Remove the four screws.
- ⑩ Remove the JFLB Assy.

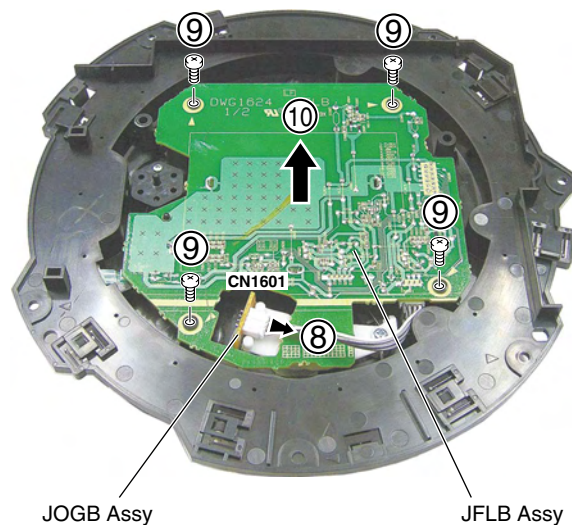

Notes on Replacement

Notes on replacing the JFLB Assy

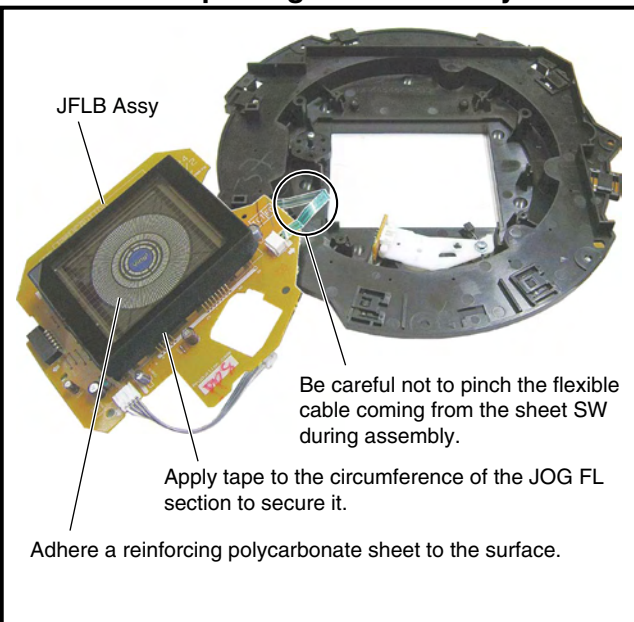

Places to Roller Assys A and B

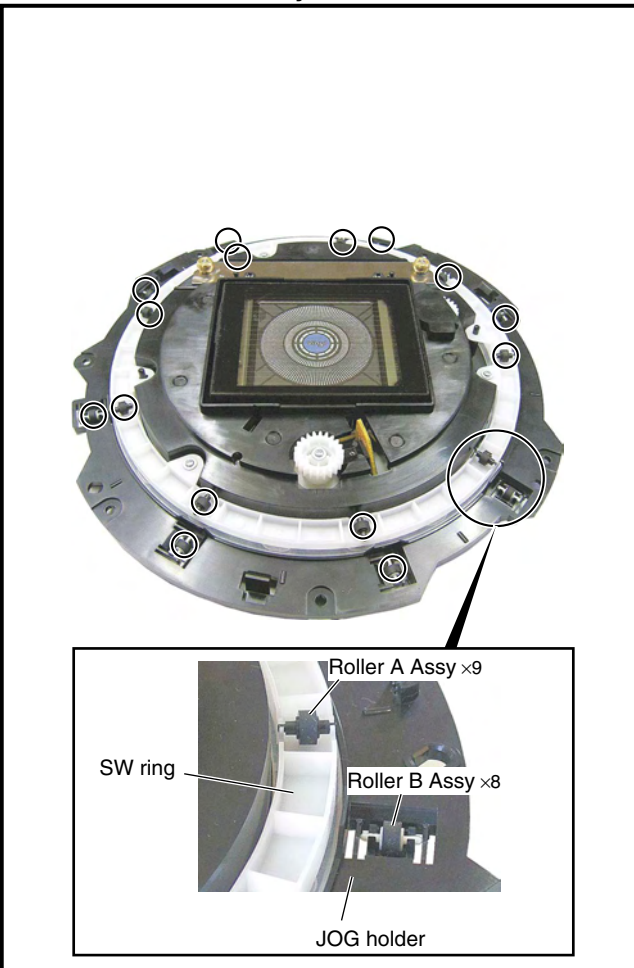

Notes on replacing the Sheet SW

Place to adhere the Sheet SW

Notes:

1. Be careful not to warp the sheet SW.
2. Remove any dirt on the JOG holder to which the sheet SW is to be adhered. If some adhesive for the old sheet SW remains on the JOG holder, completely remove it with a cloth moistened with alcohol.
3. Do NOT place the sheet SW so that it is mounted on the rib of JOG holder.
4. When adhering the sheet SW, be careful not to trap air bubbles in it. If air bubbles are formed, remove the sheet SW and adhere a new sheet SW. Do NOT reuse the removed sheet SW.
5. When making a connection, be sure to first release the lock of the connector then securely relock the connector after making the connection.

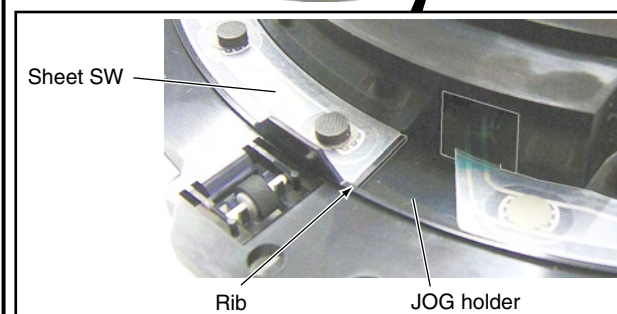
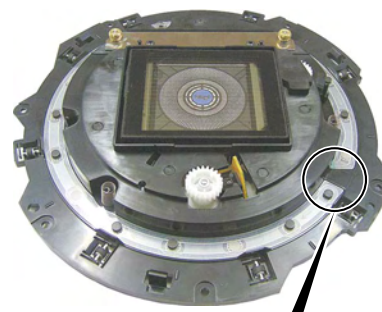

Place to adhere the SW cushions HH48/2

Adhere the cushions to the right and left of the engraved arrows (←) (12 positions in total) on the sheet SW.

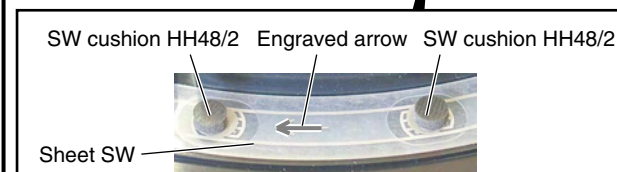
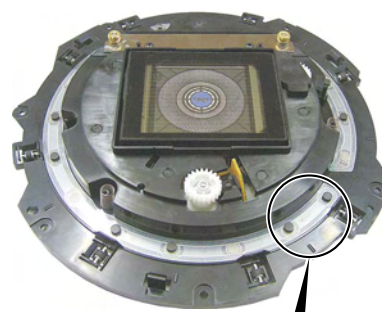

● Pin Function

No.	Pin Name	I/O	Pin Function
1	IPF	O	Correction flag output. "H" if the AOOUT output is an uncorrectable symbol in C2 correction.
2	SBOK	O	CRCC check result output for subcode Q data. "H" if the check result is OK.
3	CLCK	I/O	Clock input/output for reading subcode P to W data. The polarity of the input/output can be selected with a command.
4	VDD3	–	Power supply for 3.3V digital circuits.
5	VSS3	–	Grounding for digital circuits.
6	DATA	O	Subcode P to W data output.
7	SFSY	O	Playback section frame sync signal output.
8	SBSY	I/O	Subcode block sync output. "H" in the S1 position when a subcode sync is detected.
9	IO0A (RW)	O	"H" when the CD-RW is detected (usually "L"), and switch the OEIC gain.
10	IO1A	O	Unsetting. Always "L"
11	ARSEL	I	Usually fixed at "H" level.
12	AWRC	O	VCO control for active wide-range PLL.
13	PVDD3	–	3.3V power supply dedicated to the PLL section.
14	PDO	O	Signal output for phase difference between EFM and PLCK signals.
15	TMAXS	O	TMAX detection result output. The same signal is output from the TMAX and TMAXS pins.
16	TMAX	O	TMAX detection result output. The same signal is output from the TMAX and TMAXS pins.
17	LPFN	I	Inversion input for PLL section low-pass filter amplifier.
18	LPFO	O	Output for PLL section low-pass filter amplifier.
19	PVREF	–	1.65V reference voltage dedicated to the PLL section.
20	VCOF	O	VCO filter pin.
21	VCOREF	I	Input for VCO center frequency reference level.
22	DTCN	O	Analog slicer filter.
23	DTCP	O	Analog slicer filter.
24	PVSS3	–	Grounding dedicated to the PLL section.
25	SLCO	I	EFM slice level output.
26	RFI	I	RF signal input. An input resistance can be selected using a command.
27	RFRPI	I	RF ripple signal input.
28	RFEQO	O	RF equalizer circuit output.
29	AVDD3	–	Power supply for 3.3V analog circuits.
30	RESIN	I	Pin for connecting a resistor for reference current generation.
31	VRO	O	1.65V reference voltage output.
32	VMDIR	–	1.533V reference voltage output.
33	TESTR	O	Pin for connecting filter for RFEQO offset correction.
34	INVSEL	I	Test pin, usually fixed at "L" level.
35	AGCI	I	Input for RF signal amplitude adjustment amp.
36	RFDCI	I	Input for RF signal peak detection.
37	RFO	O	Output for RF signal generation amp.
38	PNSEL	I	Test pin, usually fixed at "H" level.
39	EQSET	O	External-connection for RF signal equalizer.
40	RVDD3	–	Power supply for 3.3V RF amp. core section.
41	LDO	O	Laser diode amp. output.
42	MDI	I	Monitor photodiode amp. input.
43	RVSS3	–	Grounding for 3.3V RF amp. core section.
44	FNI2	I	Main beam input. To be connected to PIN diode C.
45	FNI1	I	Main beam input. To be connected to PIN diode A.
46	FPI2	I	Main beam input. To be connected to PIN diode D.
47	FPI1	I	Main beam input. To be connected to PIN diode B.
48	TPI	I	Subbeam input. To be connected to PIN diode F.
49	FNI	I	Subbeam input. To be connected to PIN diode E.

No.	Pin Name	I/O	Pin Function
50	FTE	O	Focus/tracking signal output. (Test pin for servo characteristic measurement.)
51	RFZI	I	Input for RF ripple zero-cross signal.
52	AVSS3	–	Grounding for analog circuits.
53	RFRP	O	RF ripple signal output.
54	RFDC	O	Pin for the RF peak detection signal supporting hologram.
55	FEI	O	Focus error signal pin.
56	SBAD	O	Subbeam addition signal pin.
57	TEI	O	Tracking error signal pin.
58	TEZI	I	Input for tracking error signal zero-cross.
59	AVDD3	–	Power supply for 3.3V analog circuits.
60	FOO	O	Focus equalizer output.
61	TRO	O	Tracking equalizer output.
62	VREF	O	Reference voltage for analog circuits.
63	FMO	O	Speed error/feed equalizer output.
64	DMO	O	Disc equalizer output.
65	IO2A	O	Unsetting. Always "L"
66	IO3A	O	Unsetting. Always "L"
67	MONIT	O	Pin for monitoring signals in the DSP.
68	FGIN	I	FG signal input for CAV. CLV: "L", CAV: FG input
69	VSS3	–	Grounding for digital circuits.
70	VDD3	–	Power supply for 3.3V digital circuits.
71	TESIN	I	Test input pin, usually fixed at "L" level.
72	XVSS3	–	Grounding for system clock oscillator circuit.
73	XI	I	Input for system clock oscillator circuit.
74	XO	O	Output for system clock oscillator circuit.
75	XVDD3	–	Power supply for 3.3V system clock oscillator circuit.
76	DVSS3	–	Grounding for 1-bit DAC.
77	RO	O	R channel data normal output for 1-bit DAC.
78	DVDD3	–	3.3V power supply for 1-bit DAC.
79	DVR	O	Reference voltage for 1-bit DAC.
80	LO	O	L channel data normal output for 1-bit DAC.
81	DVSS3	–	Grounding for 1-bit DAC.
82	ZDET	O	Zero detection flag output for 1-bit DAC.
83	VSS5	–	Grounding for interface.
84	BUS0	I/O	Data input/output for the microcomputer interface
85	BUS1	I/O	Data input/output for the microcomputer interface
86	BUS2	I/O	Data input/output for the microcomputer interface
87	BUS3	I/O	Data input/output for the microcomputer interface
88	BUCK	I	Clock input for the microcomputer interface
89	/CCE	I	Chip enable signal input for the microcontroller interface. BUS3 to BUS0 are active if this pin is "L".
90	/RST	I	Reset signal input. The internal registers and servo section registers are reset, respectively, when the reset signal is "L" and on the rising edge of the reset signal.
91	VDD5	–	Power supply for the interface,
92	IO0B (TEZC)	O	The signal that inverts H/L with TE zero-cross.
93	IO1B (DFCT)	O	Defect signal. Normally "H", but it becomes "L" when detecting dirt on the disc.
94	IO2B (TRSR)	O	It becomes "L" during tracking close or search.
95	IO3B (HYS)	O	It becomes "L" in the hysteresis operation.
96	EMPH	O	Emphasis flag output. EMPH ON: "H", EMPH OFF: "L" The output polarity is switched, using a command.
97	BCK	O	Bit clock output. 32fs, 48fs and 64fs are selected, using a command.
98	AOUT	O	Audio data output. Which bit is first (MSB first or LSB first) can be selected, using a command.
99	LRCK	O	LR channel clock output. L ch: "L", R ch: "H" The output polarity can be inverted, using a command.
100	DOUT	O	Digital-out output

DYW1753 (MAIN ASSY : IC300)

• Flash ROM

● Pin Arrangement (Top view)

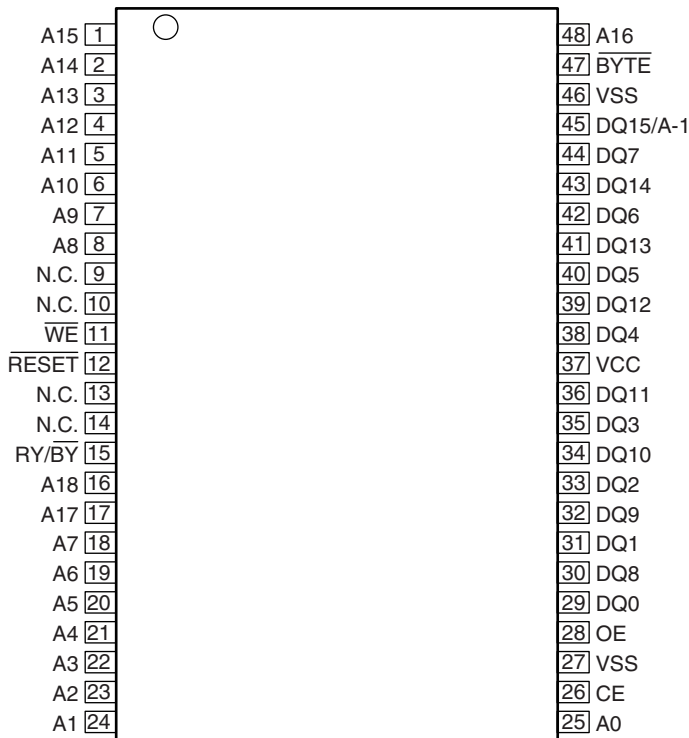

● Block Diagram

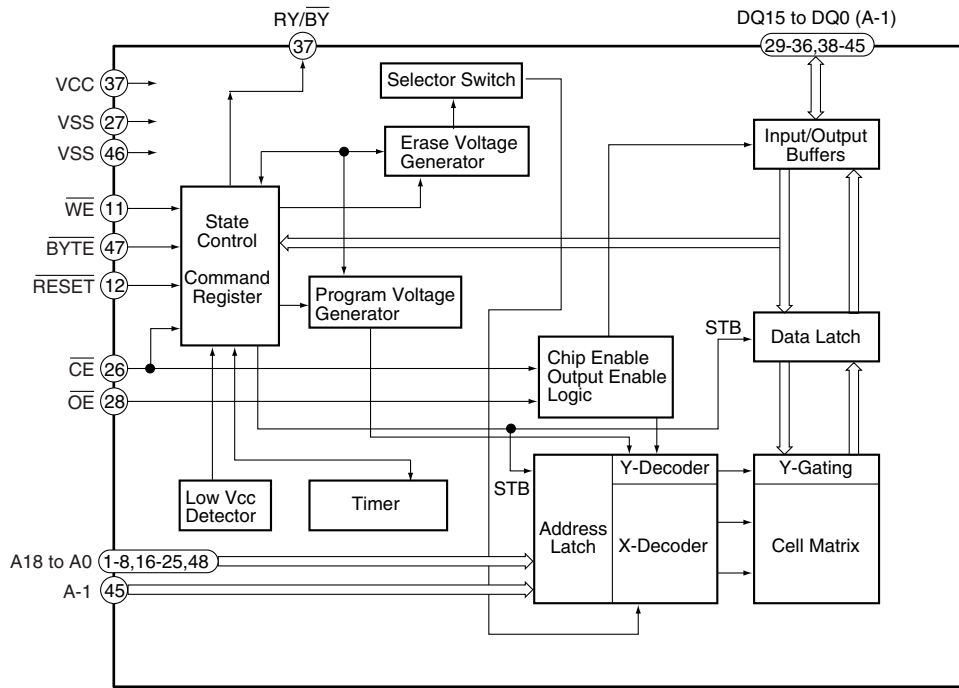

● Pin Function

No.	Pin Name	I/O	Pin Function	No.	Pin Name	I/O	Pin Function
1	A15	I	Address input	25	A0	I	Address input
2	A14	I	Address input	26	\overline{CE}	I	Chip enable
3	A13	I	Address input	27	VSS	–	Ground
4	A12	I	Address input	28	\overline{OE}	I	Output enable
5	A11	I	Address input	29	DQ0	I/O	Data input/output
6	A10	I	Address input	30	DQ8	I/O	Data input/output
7	A9	I	Address input	31	DQ1	I/O	Data input/output
8	A8	I	Address input	32	DQ9	I/O	Data input/output
9	N.C.	–	No connection	33	DQ2	I/O	Data input/output
10	N.C.	–	No connection	34	DQ10	I/O	Data input/output
11	\overline{WE}	I	Write enable	35	DQ3	I/O	Data input/output
12	\overline{RESET}	I	Hardware reset	36	DQ11	I/O	Data input/output
13	N.C.	–	No connection	37	VCC	–	Power supply
14	N.C.	–	No connection	38	DQ4	I/O	Data input/output
15	$\overline{RY/BY}$	O	Ready/Busy output	39	DQ12	I/O	Data input/output
16	A18	I	Address input	40	DQ5	I/O	Data input/output
17	A17	I	Address input	41	DQ13	I/O	Data input/output
18	A7	I	Address input	42	DQ6	I/O	Data input/output
19	A6	I	Address input	43	DQ14	I/O	Data input/output
20	A5	I	Address input	44	DQ7	I/O	Data input/output
21	A4	I	Address input	45	DQ15/A-1	I/O	Data input/output / Address input
22	A3	I	Address input	46	VSS	–	Ground
23	A2	I	Address input	47	\overline{BYTE}	I	Selects 8-bit or 16-bit mode
24	A1	I	Address input	48	A16	I	Address input

■ SCF5249LAG140 (MAIN ASSY : IC301)

- 32-bit RISC MPU

● Block Diagram

SCF5249 Block Diagram

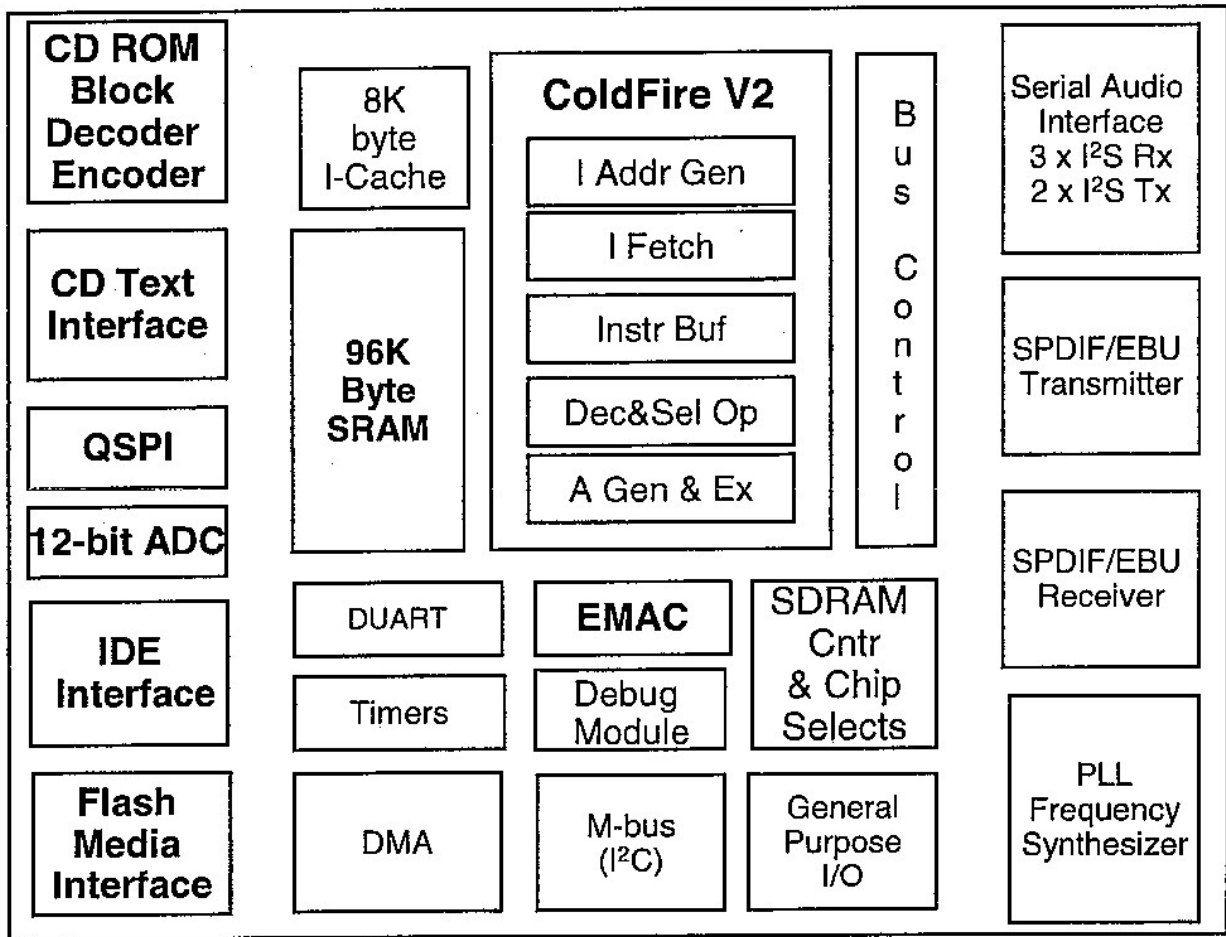

Figure 1. SCF5249 Block Diagram

**IC301 : SCF5249VM140
_No.1/4**
● Pin Function

No.	Pin Name	I/O	Pin Function
D4	SCL/QSPI_CLK	I/O	IIC clock/QSPI clock pin function select is PLLCR(11)
A1	CS0	O	Static chip select 0
D3	A21	O	SDRAM address / static adr
B1	A11	O	SDRAM address / static adr
C2	A10	O	SDRAM address / static adr
C1	A9	O	SDRAM address / static adr
E3	CMD_SDIO2/GPIO34	IO	MemoryStick/SD
D2	A18	O	SDRAM address / static adr
D1	A17	O	SDRAM address / static adr
E2	BCLK/GPIO10	I/O	SDRAM clock output
F3	SCLK_OUT/GPIO15	I/O	MemoryStick/SD
E1	BCKE	O	SDRAM clock enable output
E4	SDA/QSPI_DIN	I/O	IIC data/QSPI data in function select is PLLCR(11)
F2	DATA24	I/O	Data bus bit 24
G3	A22	O	SDRAM address / static adr
F1	SDUDQM	O	SDRAM UDQM
F4	EF/GPIO19	IO	Error flag input
G4	SDATA0_SDIO1/GPIO54	I/O	MemoryStick/SD
G1	DATA25	I/O	Data bus bit 25
G2	DATA26	I/O	Data bus bit 26
H3	RSTO/SDATA2_BS2	I/O	Reset output/MemoryStick/SD/
H1	DATA27	I/O	Data bus bit 27
H4	PAD-GND	-	PAD-GND
H4	PAD-GND	-	PAD-GND
H2	DATA28	I/O	Data bus bit 28
J1	DATA29	I/O	Data bus bit 29
J3	SDATA3/GPIO56	IO	SD interface data line
J2	DATA30	I/O	Data bus bit 30
J4	BUFENB1/GPIO57	IO	External buffer 1 enable
K1	DATA31	I/O	Data bus bit 31
K6	CORE-VDD	-	CORE-VDD
K6	CORE-VDD	-	CORE-VDD
K2	A13	O	SDRAM address / static adr
K3	A25/GPO8	O	SDRAM address / static adr
K5	CORE-GND	-	CORE-GND
K5	CORE-GND	-	CORE-GND
K4	A 23	O	SDRAM address / static adr
L1	A14	O	SDRAM address / static adr
L2	A15	O	SDRAM address / static adr
M1	A16	O	SDRAM address / static adr
L3	PAD-VDD	-	PAD-VDD
L3	PAD-VDD	-	PAD-VDD
M2	A19	O	SDRAM address / static adr
N1	A20	O	SDRAM address / static adr
L4	QSPI_CS1/GPIO24	IO	QSPI select 1
M3	TEST2	I	Structural test
N2	SDRAM_CS1	O	SDRAM chip select out 1
M4	SDATA1_BS1/GPIO9	I/O	MemoryStick/SD
P1	SDRAS	O	SDRAM RAS
P2	SDCAS	O	SDRAM CAS
N3	SDWE	O	SDRAM write enable
P3	SDLDQM	O	SDRAM LDQM
N4	GPIO5	I/O	General purpose i/o
P4	QSPI_CS0/GPIO29	I/O	QSPI chip select 0
N5	QSPI_DOUT/GPIO26	I/O	Qspi data out

IC301 : SCF5249VM140_No.2/4

No.	Pin Name	I/O	Pin Function
L5	GPIO6	I/O	General purpose i/o
P5	DATA21	I/O	Data bus bit 21
N6	DATA19	I/O	Data bus bit 19
L6	QSPI_CS2/GPIO21	I/O	QSPI chip select 2
P6	DATA20	I/O	Data bus bit 20
L7	DATA22	I/O	Data bus bit 22
P7	DATA18	I/O	Data bus bit 18
K7	DATA23	I/O	Data bus bit 23
N7	DATA17	I/O	Data bus bit 17
L8	QSPI_CS3/GPIO22	IO	QSPI Chip Select 3
K8	PAD-VDD	-	PAD-VDD
K8	PAD-VDD	-	PAD-VDD
P8	DATA16	I/O	data bus bit 16
N8	SDRAM_CS2/GPIO7	I/O	SDRAM chip select out 2 gpo
P9	EBUOUT2/GPO37	O	Audio interfaces EBU out 2
L9	CFLG/GPIO18	IO	CFLG input
N9	EBUOUT1/GPO36	O	Audio interfaces EBU out 1
K9	CORE-GND	-	CORE-GND
K9	CORE-GND	-	CORE-GND
P10	EBUIN3/ADIN0/GPI38	I	Audio interfaces EBU in 3 A/D convertor input 0
N10	EBUIN2/GPI37	I	Audio interfaces EBU in 2
L10	CORE-VDD	-	CORE-VDD
L10	CORE-VDD	-	CORE-VDD
P11	SCL2/GPIO3	I/O	IIC clock
P12	RSTI	I	Reset input
N11	TOUT1/ADOUT/GPO35	O	Timer output 1/ad output
P13	LRCK2/GPIO44	IO	Audio interfaces serial word clock 2
N12	OE	O	Output Enable
M11	SDA2/GPIO55	I/O	IIC 2 data line
P14	SDATAO2/GPO41	O	Audio interfaces serial data 2 out
N13	SCLK2/GPIO48	IO	Audio interfaces serial clock 2
K10	PAD-GND	-	PAD-GND
K10	PAD-GND	-	PAD-GND
K11	BUFENB2/GPIO17	IO	External buffer 2 enable
M12	TEST3	I	Structural test
L12	SDATAO1/GPIO25	IO	Audio interfaces serial data 1 out
N14	LRCK1	IO	Audio interfaces serial word clock 1
M13	LRCK4/GPIO46	IO	Audio interfaces serial word clock 4
M14	SDATAI4/GPI42	I	Audio interfaces serial data 4 in
L13	SCLK1	IO	Audio interfaces serial clock 1
L14	SCLK4/GPIO50	IO	Audio interfaces serial clock 4
L11	TA/GPIO20	I/O	Transfer Acknowledge
K13	SDATAI1	I	Audio interfaces serial data 1 in
K12	EBUIN1/GPI36	I	Audio interfaces EBU in 1
K14	PLLGRDVDD	IO	PLL guard supply (1.8V)
J11	PLLGRDGND	-	PLL guard supply GND
J13	PLLPADGND	-	3.3 Volt PLL GND
J12	PLLPADVDD	-	3.3 Volt PLL VDD
J14	PLLCOREGND	-	1.8 Volt PLL analog supply-GND
H11	PLLCOREVDD	-	1.8 Volt PLL analog supply-VDD
H12	IDE-DIOW/GPIO14	IO	ide diow
H14	CRIN	I	crystal
H13	IDE-DIOR/GPIO13	IO	IDE DIOR
G11	IDE-IORDY/GPIO16	I/O	IDE IORDY

IC301 : SCF5249VM140_No.3/4

No.	Pin Name	I/O	Pin Function
G11	IDE-IORDY/GPIO16	I/O	IDE IORDY
G14	MCLK1/GPO39	O	Audio master clock output 1
G12	SUBR/GPIO53	IO	Subcode data
G13	MCLK2/GPO42	O	Audio master clock output 2
F14	XTRIM/GPO38	O	Audio interfaces X-tal trim
F11	TRST/DSCLK	I	Jtag
F13	SFSY/GPIO52	IO	Subcode sync
E9	CORE-VDD	-	CORE-VDD
E9	CORE-VDD	-	CORE-VDD
E14	RW_B	O	Bus write enable
F12	RCK/GPIO 51	IO	Subcode clock
E13	TMS/BKPT	I	Jtag
E10	CORE-GND	-	CORE-GND
E10	CORE-GND	-	CORE-GND
E12	TCK	I	Jtag
E11	PAD-GND	-	PAD-GND
E11	PAD-GND	-	PAD-GND
D14	PST3/GPIO 62	IO	ColdFire debug port
D13	CNPSTCLK/GPO 63	O	Coldfire debug clock
C14	PST1/GPIO 60	IO	ColdFire debug port
D12	PAD-VDD	-	PAD-VDD
D12	PAD-VDD	-	PAD-VDD
C13	PST2/GPIO 61	IO	ColdFire debug port
B14	PST0/GPIO 59	IO	ColdFire debug port
D11	TDI/DSI	I	Jtag
C12	TEST0	I	Structural test
B13	TIN0/GPI33	i	Timer input 0
C11	HI-Z	I	Jtag
A14	DDATA 3 / GPIO 4	IO	ColdFire debug port
A13	TOUTO / GPO33	O	Timer output 0
B12	DDATA1/GPIO 1	IO	ColdFire debug port
A12	DDATA2/GPIO 2	IO	ColdFire debug port
B11	CTS2_B / ADIN3/GP131	I	Second UART clear to send, AD input 3
A11	DDATA0/GPIO 0	IO	ColdFire debug port
B10	RXD2 / GPI28/ADIN2	I	Second UART receive data input AD input 2
D10	TDSO	O	Jtag
A10	RTS2_B/GPO31	O	Second UART request to send
B9	SDATAI3 / GPI 41	I	audio interfaces serial data 3 in
D9	CTS1_B/GPI30	I	First UART clear to send
A9	TXD2/GPO28	O	Second UART transmit data output
D8	RTS1_B / GPO30	O	First UART request to send
A8	EBUIN4/ADIN1/GPI 39	I	audio interfaces EBU in 4/ AD convertor input 1
E8	SRE/GPIO11	IO	SmartMedia read enable
B8	LRCK3 / GPIO 45	IO	Audio interfaces serial word clock 3
E7	SWE/GPIO12	IO	SmartMedia write enable
D7	TXD1/GPO27	O	First UART transmit data output
A7	SCLK3/GPIO49	IO	Audio interfaces serial clock 3
B7	RXD1 / GPI27	I	First UART receive data input
A6	CS1 / GPIO58	IO	Static chip select 1 / gpio 1
E6	CORE-GND	-	CORE-GND
E6	CORE-GND	-	CORE-GND
B6	A1	O	Static address A1
D6	TIN1/GP1O23	IO	Timer 1 in
A5	A2	O	Static address A2

IC301 : SCF5249VM140_No.4/4

No.	Pin Name	I/O	Pin Function
B5	A3	O	Static address A3
D5	PAD-GND	-	PAD-GND
D5	PAD-GND	-	PAD-GND
A4	A4	O	Static adr 4
A3	A6	O	Static adr6
B4	A5	O	Static adr 5
A2	A8	O	Static adr 8
B3	A7	O	Static adr7
C4	CORE-VDD	-	CORE-VDD
C4	CORE-VDD	-	CORE-VDD
B2	A12	O	SDRAM address / static adr
C3	TEST1	I	Structural test
E5	PAD-VDD	-	PAD-VDD
E5	PAD-VDD	-	PAD-VDD

BA00BC0WCP-V5 (SECB ASSY : IC50, REGB ASSY : IC91, IC92)

- Regulator IC (Built-in thermal shutdown protection, output variable type)

Block Diagram

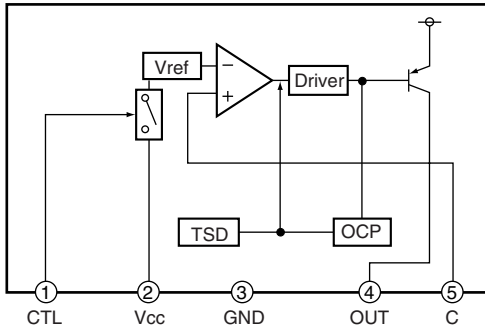

Pin Function

No.	Pin Name	I/O	Pin Function
1	CTL	I	Output switch control
2	Vcc	-	Power supply
3	GND	-	Ground
4	OUT	O	Output
5	C	I	Voltage comparison

NJM2374AM (SECB ASSY : IC51)

- PWM TYPE DC/DC CONVERTER IC

Block Diagram

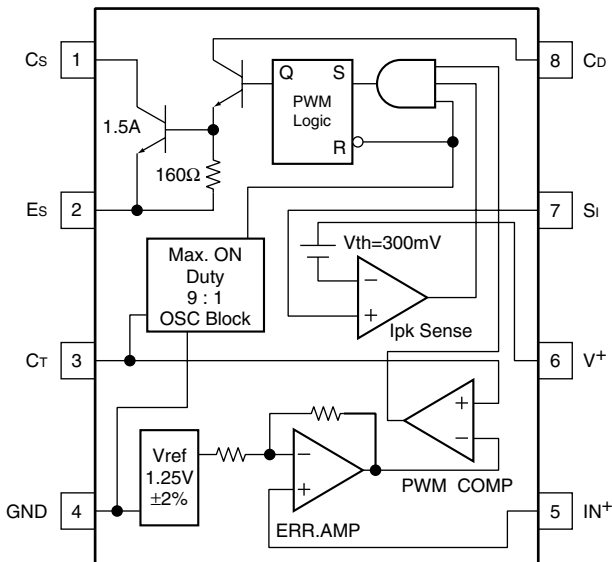

Pin Function

No.	Pin Name	I/O	Pin Function
1	Cs	I	Collector Terminal
2	Es	O	Emitter Terminal
3	Ct	I	Timing Condenser Connection
4	GND	-	Ground
5	IN+	I	Reference Voltage
6	V+	-	Power supply
7	Si	I	Current Detection Terminal
8	Cd	I	Logic Control Terminal

TC7S04FU (SECB ASSY : IC52)

- INVERTER IC (Logic IC)

Block Diagram

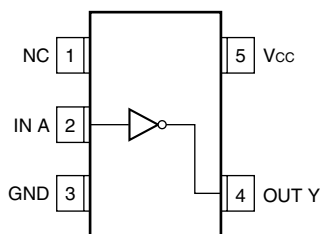

Pin Function

No.	Pin Name	I/O	Pin Function
1	NC	-	Non connection
2	IN A	I	Input
3	GND	-	Ground
4	OUT Y	O	Output
5	Vcc	-	Power supply

PEG237B (DFLB ASSY : IC501)

• Display Microcomputer

• Pin Arrangement (Top view)

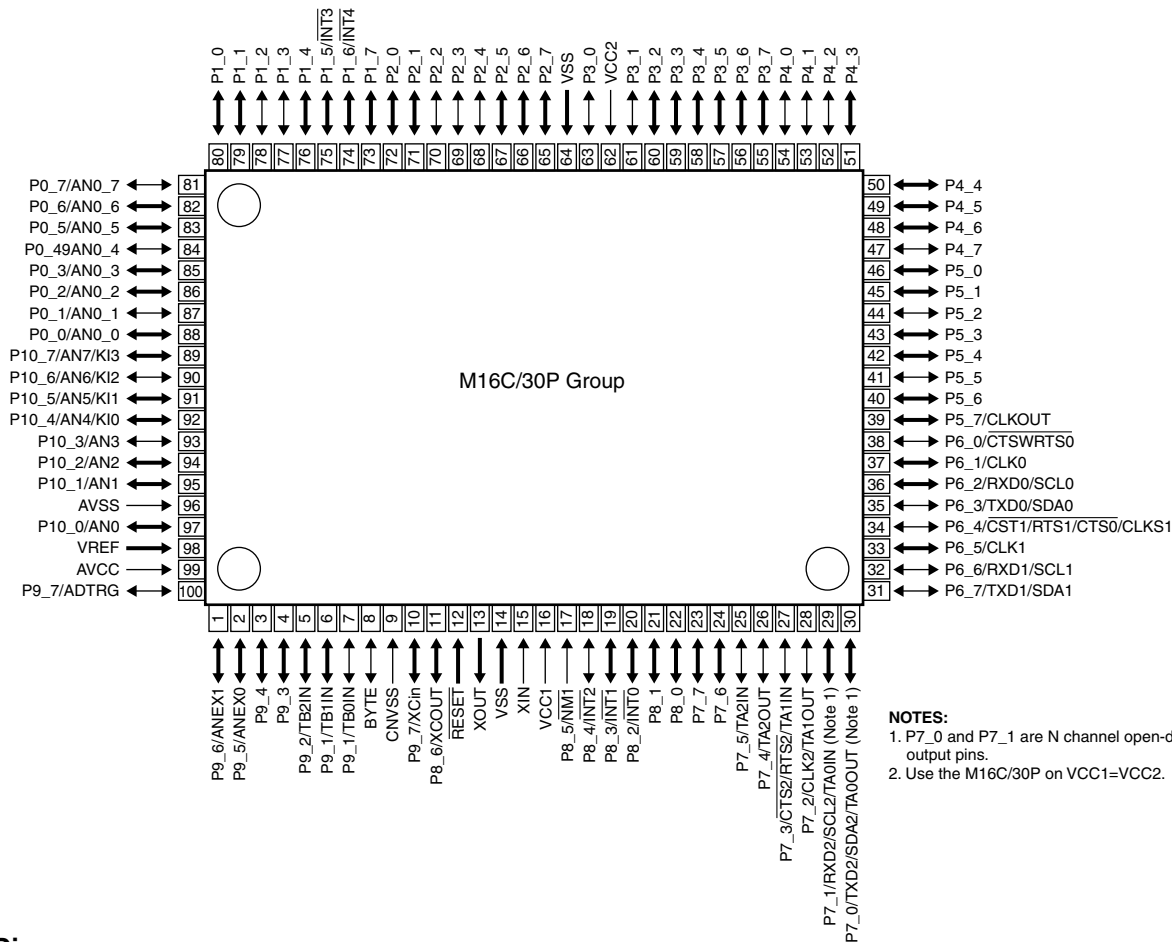

• Block Diagram

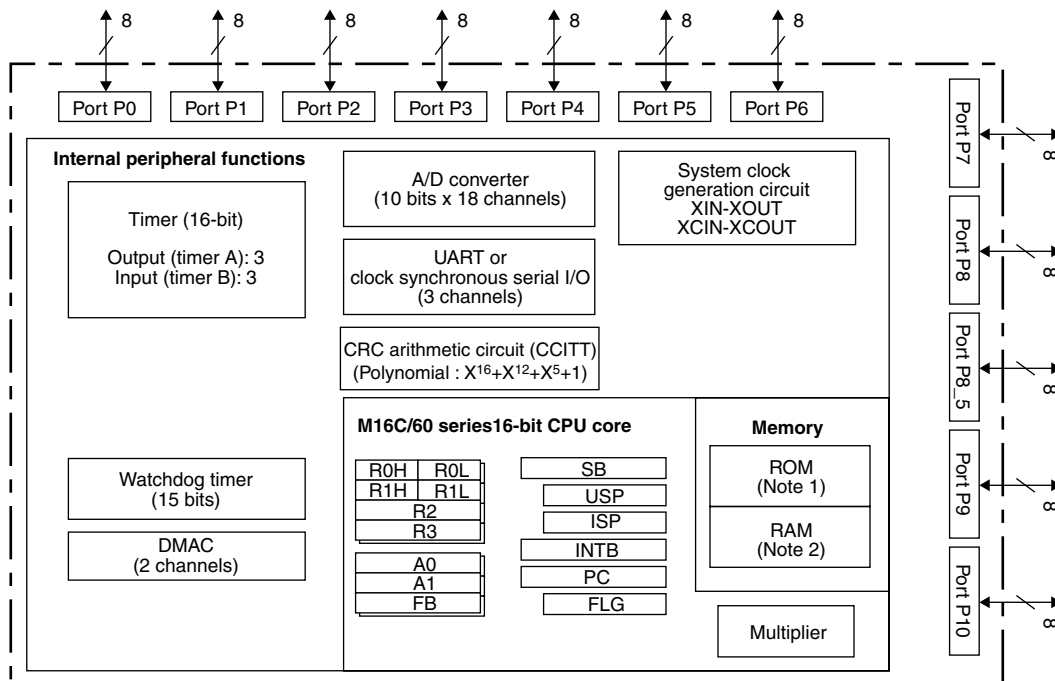

(Note 1) ROM size depends on microcomputer type.
 (Note 2) RAM size depends on microcomputer type.

● Pin Function

No.	Pin Name	I/O	Pin Function
1	–	I	Not used (ground)
2	TCH/REL	I	Volume input (A/D conversion port) For VINYL SPEED ADJUST
3	MODEL2	I	Model setting 2 Distinguish between CDJ-800MK2, CDJ-1000MK3 and DVJ-1000.
4	MODEL1	I	Model setting 1
5	–	O	Not used (non connection)
6	JOG1	I	Pulse period measurement processing
7	–	O	Not used (non connection)
8	–	–	Not used (ground)
9	CNVss	–	For built-in flash memory updating (not used)
10	–	I	Not used (ground)
11	–	I	Not used (ground)
12	XRST	–	Reset input
13	XOUT	–	16 MHz clock input
14	Vss	–	Ground
15	XIN	–	16MHz clock input
16	Vcc	–	Power supply 5 V
17	XNMI	I	
18	–	I	Not used (power supply 5 V)
19	–	I	Not used (power supply 5 V)
20	–	I	Not used (power supply 5 V)
21	–	I	Not used (power supply 5 V)
22	–	I	Not used (power supply 5 V)
23	–	I	Not used (power supply 5 V)
24	–	I	Not used (power supply 5 V)
25	JOG2	I	Two-phase pulse signal input Input signal of a TA2OUT terminal is a period of "H", up count (clockwise) at rising edge of TA2IN terminal and down count (counterclockwise) at falling edge.
26	JOG1	I	
27	TOUCH	I	JOG touch sensor
28	JSCLK	O	Serial clock signal for JOG-FL
29	–	O	Not used (non connection)
30	J_SDO	O	Communication Serial data signal for JOG-FL
31	FLSDO	O	Communication Serial data signal for DATA-FL
32	–	I	Not used (non connection) For built-in flash memory updating
33	FLSCLK	O	Communication Serial clock signal for DATA-FL
34	–	I	Not used (non connection) For built-in flash memory updating
35	SDO	O	Communication Data out signal for MPU (MAIN ASSY)
36	SDI	I	Communication Data in signal for MPU (MAIN ASSY)
37	CLK	O	Communication Clock signal for MPU (MAIN ASSY)
38	XCS	O	Communication Chip select signal for MPU (MAIN ASSY)
39	–	O	Not used (non connection)
40	–	O	Not used (non connection)
41	–	I	Not used (pull up)
42	FLLAT	O	Communication Latch signal for DATA-FL
43	FLBK	O	Communication Blank signal for DATA-FL
44	JXSTB	O	Communication Latch signal for JOG-FL
45	JBK	O	Communication Blank signal for JOG-FL
46	XCE	I	Not used (pull up)
47	LED24	O	LED control for RELOOP/EXIT button 0 : Lights-out
48	LED23	O	LED control for REALTIME CUE OUT button 0 : Lights-out
49	LED22	O	LED control for PLAY/PAUSE button 0 : Lights-out
50	LED21	O	LED control for CUE button 0 : Lights-out

● Pin Function

No.	Pin Name	I/O	Pin Function
51	LED20	O	LED control for REV button 0 : Lights-out
52	LED19	O	LED control for REALTIME CUE IN button 0 : Lights-out
53	LED18	O	LED control for AUTO BEAT LOOP 8 button 0 : Lights-out
54	LED17	O	LED control for AUTO BEAT LOOP 4 button 0 : Lights-out
55	LED16	O	LED control for AUTO BEAT LOOP 2 button 0 : Lights-out
56	LED15	O	LED control for AUTO BEAT LOOP 1 button 0 : Lights-out
57	LED14	O	LED control for QUICK RETURN button 0 : Lights-out
58	LED13	O	LED control for JOG MODE button 0 : Lights-out
59	LED12	O	LED control for MASTER TEMPO button 0 : Lights-out
60	LED11	O	LED control for TEMPO button 0 : Lights-out
61	–	O	Not used (non connection) 0 : Lights-out
62	Vcc	–	Power supply 5 V
63	–	O	Not used (non connection) 0 : Lights-out
64	Vss	–	Ground
65	–	O	Not used (non connection) 0 : Lights-out
66	–	O	Not used (non connection) 0 : Lights-out
67	–	O	Not used (non connection) 0 : Lights-out
68	–	O	Not used (non connection) 0 : Lights-out
69	–	O	Not used (non connection) 0 : Lights-out
70	–	O	Not used (non connection) 0 : Lights-out
71	–	O	Not used (non connection) 0 : Lights-out
72	–	O	Not used (non connection) 0 : Lights-out
73	–	I	Not used (ground)
74	–	I	Not used (ground)
75	–	I	Not used (ground)
76	–	I	Not used (ground)
77	–	I	Not used (ground)
78	–	I	Not used (ground)
79	SW10	I	SW input (direct port) for RELOOP/EXIT button
80	SW09	I	SW input (direct port) for PLAY/PAUSE button
81	SW08	I	SW input (direct port) for CUE button
82	SW07	I	SW input (direct port) for REALTIME CUE OUT button
83	SW06	I	SW input (direct port) for REV button
84	SW05	I	SW input (direct port) for REALTIME CUE IN button
85	SW04	I	SW input (direct port) for AUTO BEAT LOOP 8 button
86	SW03	I	SW input (direct port) for AUTO BEAT LOOP 4 button
87	SW02	I	SW input (direct port) for AUTO BEAT LOOP 2 button
88	SW01	I	SW input (direct port) for AUTO BEAT LOOP 1 button
89	TEMPOR	I	SW input (A/D conversion port) for TEMPO SLIDER (2.5 V input)
90	TEMPO	I	SW input (A/D conversion port) for TEMPO SLIDER + direction: Vcc side, - direction: GND side
91	KEY0	I	SW input (A/D conversion port) for PLAY/CUE/TRACK SEARCH L/TRACK SEARCH R/SERCH L/SEARCH R button
92	KEY1	I	SW input (A/D conversion port) for FOLDER SEARCH +/-/FOLDER SEARCH -/QUICK RETURN button
93	KEY2	I	SW input (A/D conversion port) for CALL </CALL >/CUE DELETE/CUE MEMORY/TEXT MODE/TIME MODE button
94	–	I	Not used (power supply 5 V)
95	–	I	Not used (power supply 5 V)
96	AVss	–	Ground (for A/D conversion port)
97	MODEL	I	Power supply 5 V DVD destination setting
98	VREF	–	Reference voltage (for A/D conversion port)
99	AVcc	–	Power supply 5 V (for A/D conversion port)
100	–	I	Power supply 5 V

BA50BC0WFP (SECB ASSY: IC57)

- Regulator IC (Built-in thermal shutdown protection, output variable type)

A ● Block Diagram

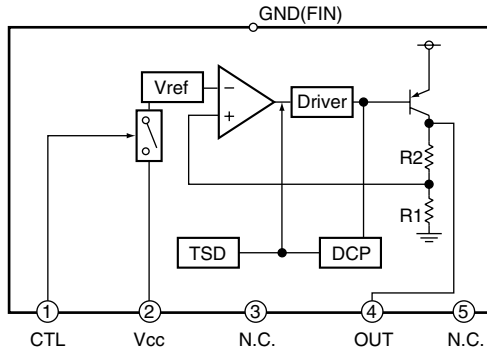

● Pin Function

No.	Pin Name	I/O	Pin Function
1	CTL	I	Output switch control
2	VCC	-	Power supply
3	N.C.	-	Non connection
4	OUT	O	Output
5	N.C.	-	Non connection
FIN	GND	-	Ground

B

NJM4558DX (JACK ASSY : IC801)

- DUAL OP-AMP IC (OP-AMP)

● Block Diagram

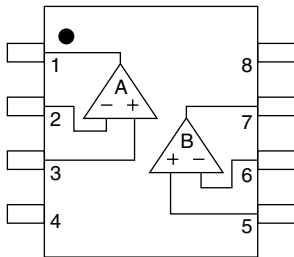

● Pin Function

No.	Pin Name	I/O	Pin Function
1	A OUTPUT	O	Output A
2	A -INPUT	I	Input A-
3	A +INPUT	I	Input A+
4	V-	-	Power supply -
5	B +INPUT	I	Input B+
6	B -INPUT	I	Input B-
7	B OUTPUT	O	Output B
8	V+	-	Power supply +

C

D

E

F

● Pin Function

TERMINAL	SYMBOL	TERMINAL FUNCTION	TERMINAL	SYMBOL	TERMINAL FUNCTION
1	SL1IN	Slide control voltage input 1	4 2	OSC	PWM carrier oscillation set
2	SL2IN	Slide control voltage input 2	4 1	MU1	mute / brake select terminal 1
3	VM2	Motor Power Supply 2 (for Slide)	4 0	LOIN+	Loading control input(+)
4	RSL2	Slide current sense 2	3 9	VM3	Power Supply3 (for Loading)
5	SL2+	Slide non-inverted output 2	3 8	MU2	mute / brake select terminal 2
6	SL2-	Slide inverted output 2	3 7	LO-	Loading inverted output
7	GND	GND	3 6	LO+	Loading non-inverted output
8	RSL1	Slide current sense 1	3 5	FO-	Focus inverted output
9	SL1+	Slide non-inverted output 1	3 4	FO+	Focus non-inverted output
10	SL1-	Slide inverted output 1	3 3	GND	GND
11	GND	GND	3 2	VCC	Power Supply (for FS ,TS)
12	W	Motor drive output W	3 1	TO+	Tracking non-inverted output
13	V	Motor drive output V	3 0	TO-	Tracking inverted output
14	U	Motor drive output U	2 9	GND	GND
15	RSP	Spindle current sense	2 8	TOIN	Tracking control voltage input
16	HW-	HW- sensor amp. input	2 7	FOIN	Focus control voltage input
17	HW+	HW+ sensor amp. input	2 6	SPIN	Spindle control voltage input
18	HV-	HV- sensor amp. input	2 5	REF1	Reference voltage input 1 (for Spindle>Loading)
19	HV+	HV+ sensor amp. input	2 4	FG	Frequency generator output
20	HU-	HU- sensor amp. input	2 3	REF2	Reference voltage input 2 (for Slide>Focus>Tracking)
21	HU+	HU+ sensor amp. input	2 2	VM1	Motor Power Supply 1 (for Spindle)

XC3S50-4VQG100C-K (MAIN ASSY : IC302)

• FPGA IC

● Pin Arrangement (Top view)

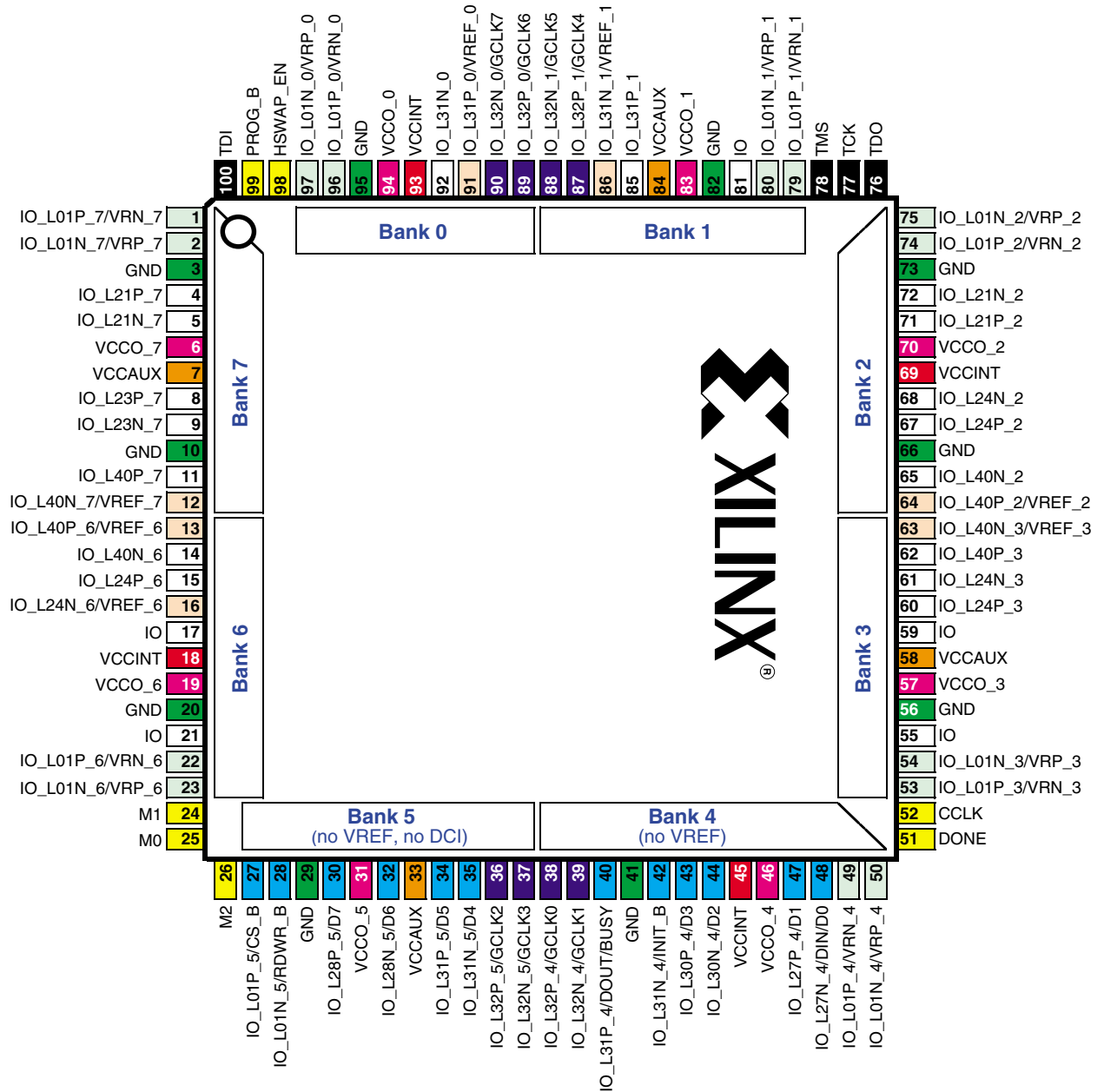
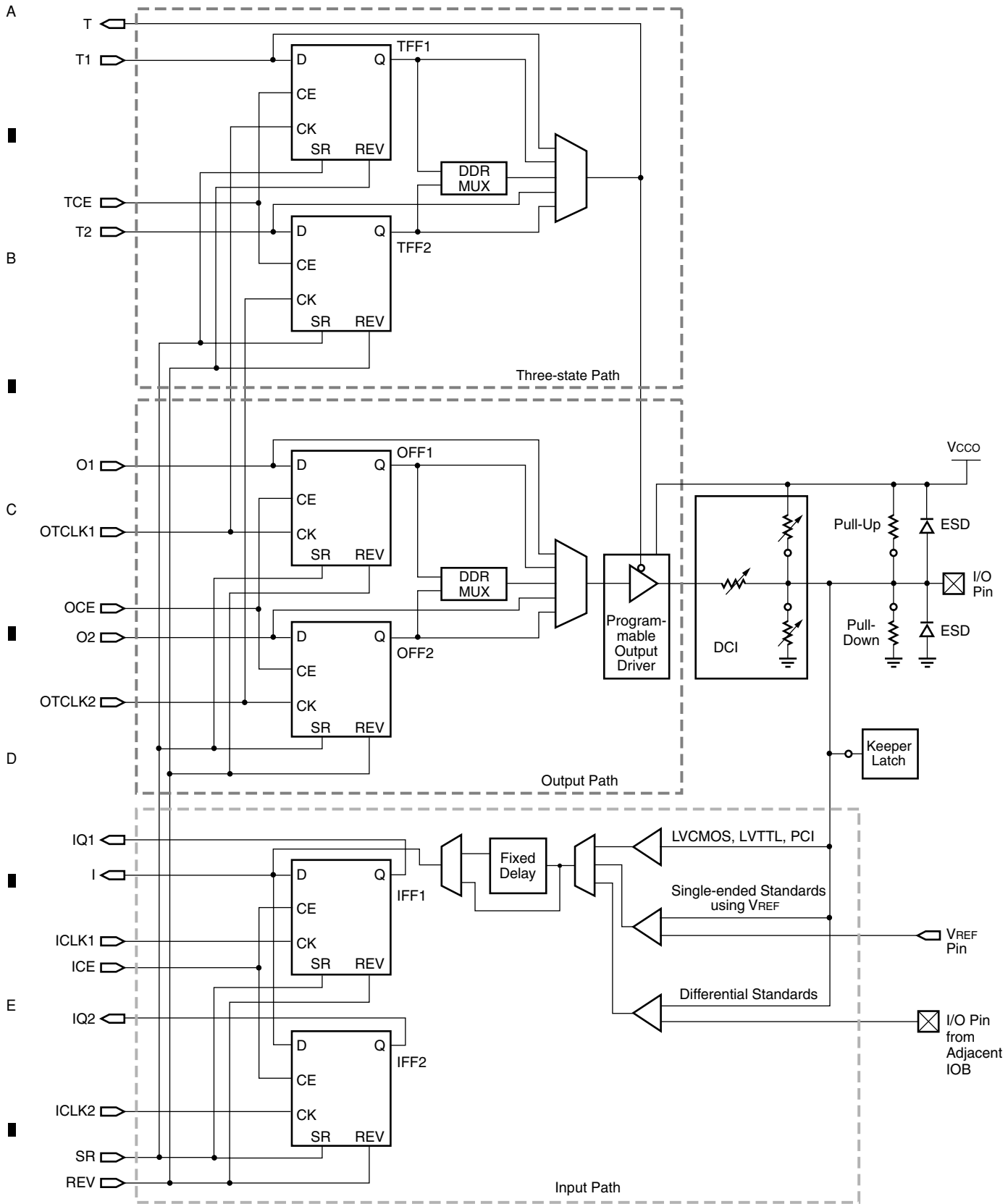

Figure 5 : VQ100 Package Footprint (top view). Note pin 1 indicator in top-left corner and logo orientation.

22	I/O: Unrestricted, general-purpose user I/O	12	DUAL: Configuration pin, then possible user I/O	7	VREF: User I/O or input voltage reference for bank
14	DCI: User I/O or reference resistor input for bank	8	GCLK: User I/O or global clock buffer input	8	VCCO: Output voltage supply for bank
7	CONFIG: Dedicated configuration pins	4	JTAG: Dedicated JTAG port pins	4	VCCINT: Internal core voltage supply (+1.2V)
0	N.C.: No unconnected pins in this package	10	GND: Ground	4	VCCAUX: Auxiliary voltage supply (+2.5V)

● Block Diagram



Note : All IOB signals communicating with the FPGA's internal logic have the option of inverting polarity.

Figure 1: Simplified IOB Diagram

● Block Diagram

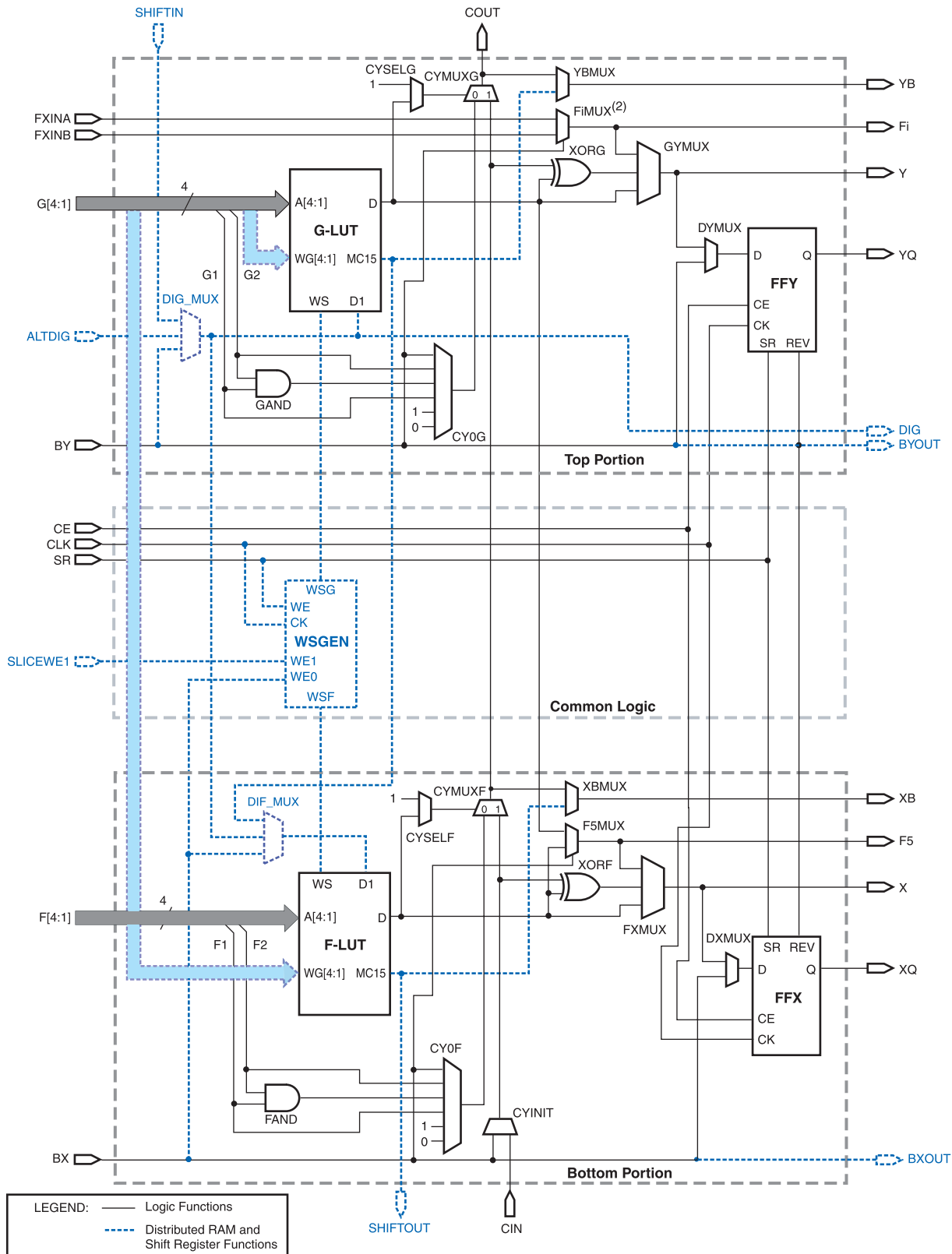

Notes:

- Options to invert signal polarity as well as other options that enable lines for various functions are not shown.
- The index *i* can be 6, 7, or 8, depending on the slice. In this position, the upper right-hand slice has an F8MUX, and the upper left-hand slice has an F7MUX. The lower right-hand and left-hand slices both have an F6MUX.

Figure 6 : Simplified Diagram of the Left-Hand SLICEM

K4S641632K-UC75 (MAIN ASSY : IC303)

• SDRAM (64Mbit)

Pin Arrangement (Top view)

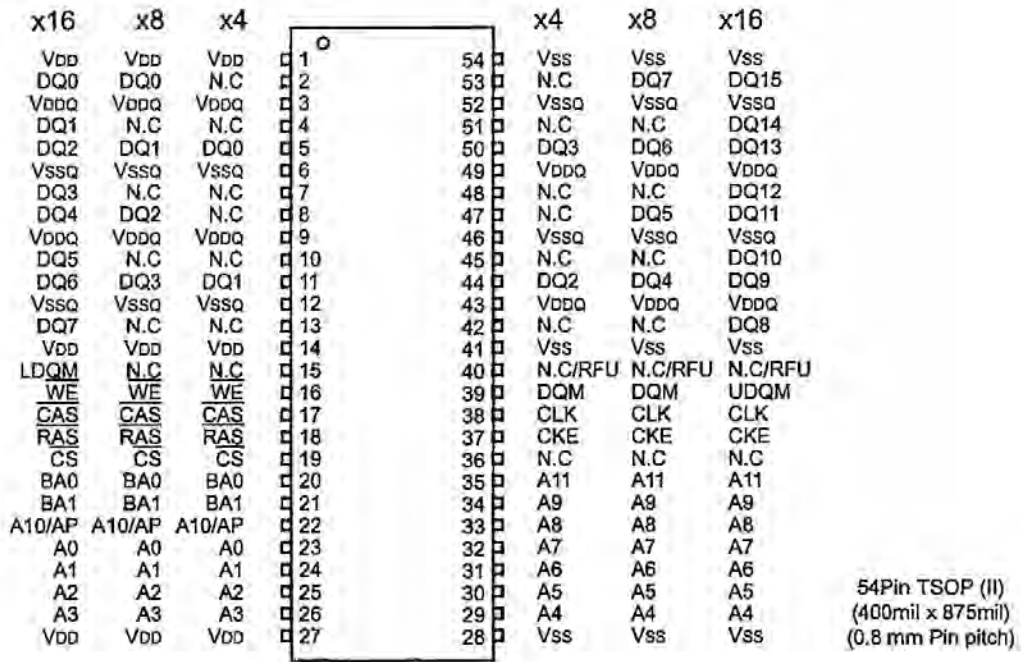

Block Diagram

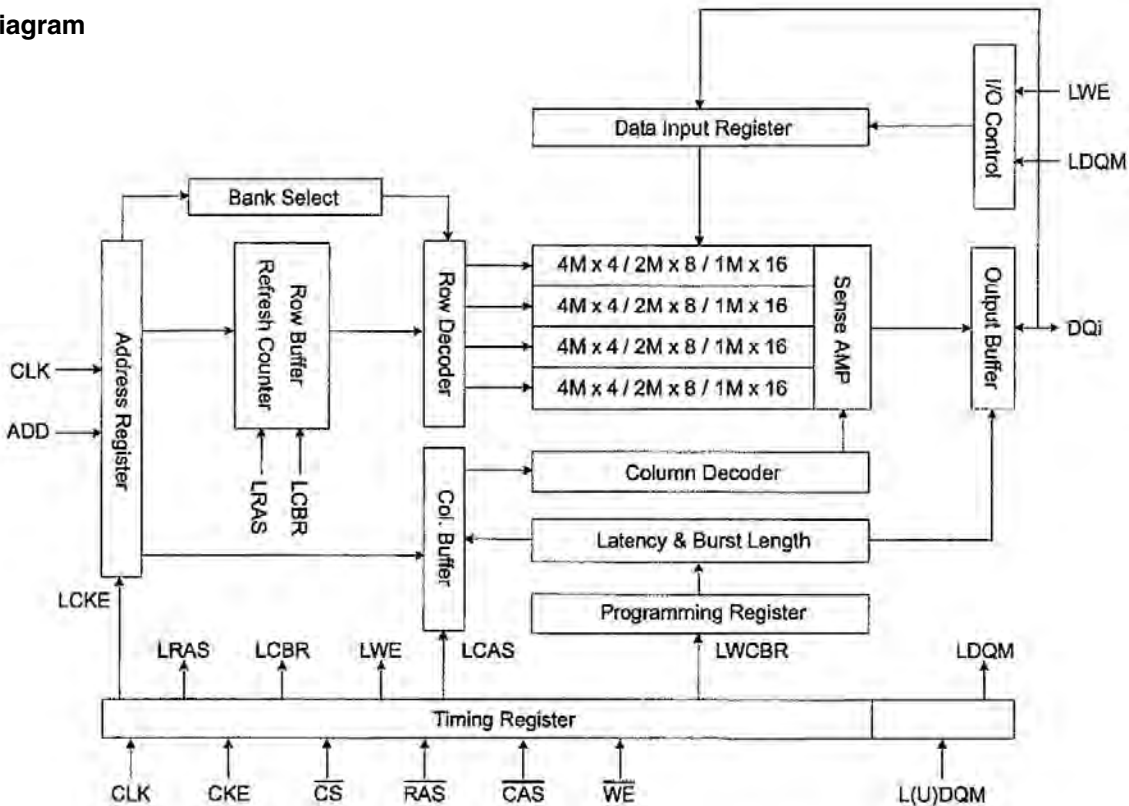

* Samsung Electronics reserves the right to change products or specification without notice.

● Pin Function

Pin	Name	Input Function
CLK	System clock	Active on the positive going edge to sample all inputs.
\overline{CS}	Chip select	Disables or enables device operation by masking or enabling all inputs except CLK, CKE and DQM
CKE	Clock enable	Masks system clock to freeze operation from the next clock cycle. CKE should be enabled at least one cycle prior to new command. Disable input buffers for power down in standby.
A ₀ – A ₁₁	Address	Row/column addresses are multiplexed on the same pins. Row address : RA ₀ ~ RA ₁₁ , Column address : CA ₀ ~ CA ₉
BA ₀ ~ BA ₁	Bank select address	Selects bank to be activated during row address latch time. Selects bank for read/write during column address latch time.
\overline{RAS}	Row address strobe	Latches row addresses on the positive going edge of the CLK with \overline{RAS} low. Enables row access & precharge.
\overline{CAS}	Column address strobe	Latches column addresses on the positive going edge of the CLK with \overline{CAS} low. Enables column access.
\overline{WE}	Write enable	Enables write operation and row precharge. Latches data in starting from \overline{CAS} , \overline{WE} active.
DQM	Data input/output mask	Makes data output Hi-Z, tSHZ after the clock and masks the output. Blocks data input when DQM active.
DQ ₀ ~ X ₁₅	Data input/output	Data inputs/outputs are multiplexed on the same pins.
V _{DD} /V _{SS}	Power supply/ground	Power and ground for the input buffers and the core logic.
V _{DDQ} /V _{SSQ}	Data output power/ground	Isolated power supply and ground for the output buffers to provide improved noise immunity.
N.C./RFU	No connection /reserved for future use	This pin is recommended to be left No Connection on the device.

■ BU4230G (MAIN ASSY : IC304)

• RESET IC

● Block Diagram

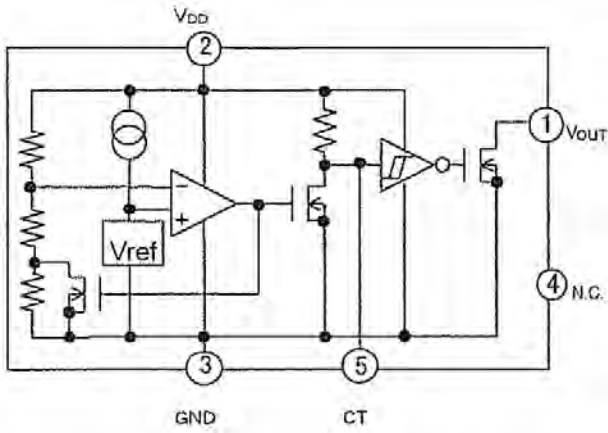

● Pin Function

Pin Number	Pin Name
1	V _{OUT}
2	V _{DD}
3	GND
4	N.C.
5	CT

■ DSPC56371AF180 (MAIN ASSY : IC701)

• DSP IC

● Pin Arrangement (Top view)

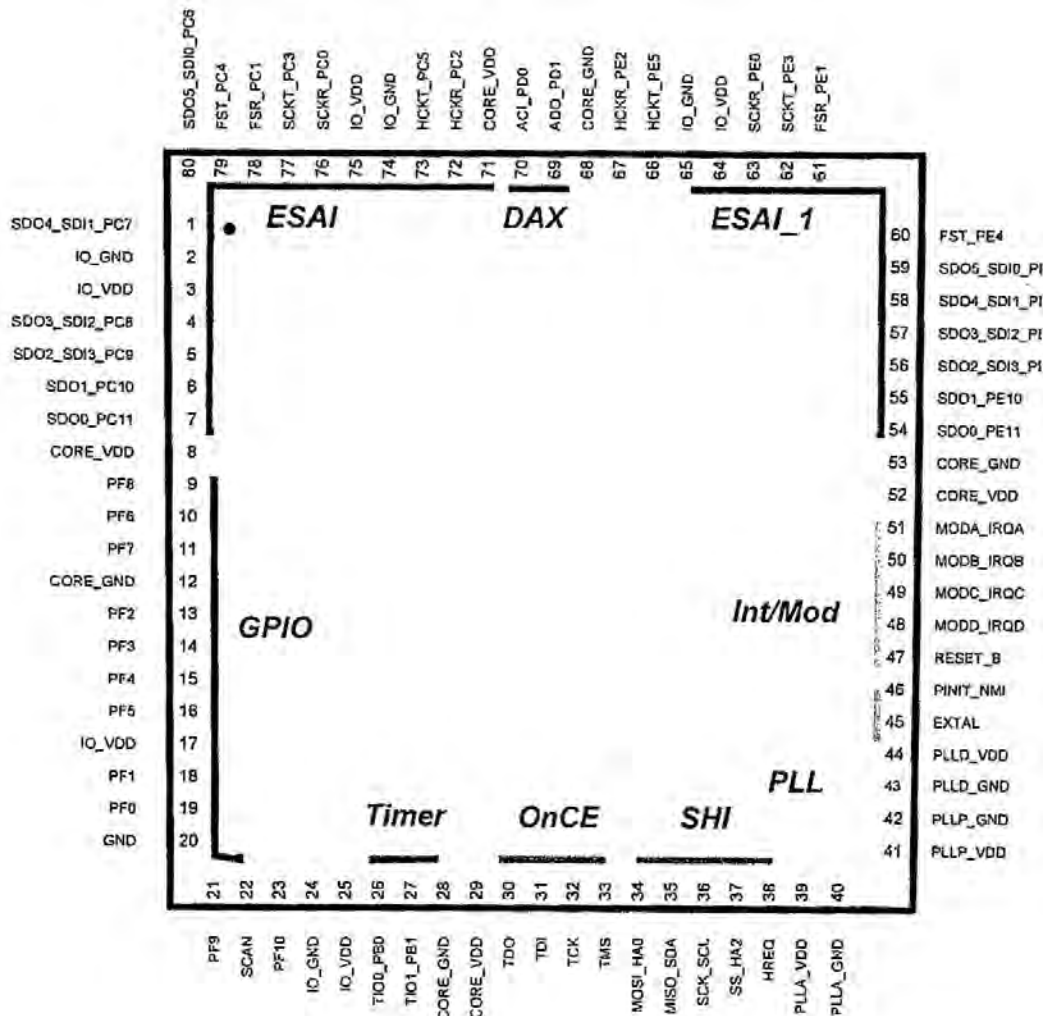

● Pin Function

Pin No.	Pin Name	Pin No.	Pin Name	Pin No.	Pin Name	Pin No.	Pin Name
1	SDO4_SDM_PC7	21	PF9	41	PLL_P_VDD	61	FSR_PE1
2	IO_GND	22	SCAN	42	PLL_P_GND	62	SCKT_PE3
3	IO_VDD	23	PF10	43	PLL_D_GND	63	SCKR_PE0
4	SDO3_SDI2_PC8	24	IO_GND	44	PLL_D_VDD	64	IO_VDD
5	SDO2_SDI3_PC9	25	IO_VDD	45	EXTAL	65	IO_GND
6	SDO1_PC10	26	TIO0_PB0	46	PINIT_NMI	66	HCKT_PE5
7	SDO0_PC11	27	TIO1_PB1	47	RESET_B	67	HCKR_PE2
8	CORE_VDD	28	CORE_GND	48	MODD_IRQD	68	CORE_GND
9	PF8	29	CORE_VDD	49	MODC_IRQC	69	ADO_PD1
10	PF6	30	TDO	50	MODB_IRQB	70	ADI_PD0
11	PF7	31	TDI	51	MODA_IRQA	71	CORE_VDD
12	CORE_GND	32	TCK	52	CORE_VDD	72	HCKR_PC2
13	PF2	33	TMS	53	CORE_GND	73	HCKT2_PC5
14	PF3	34	MOSI_HA0	54	SDO0_PE11	74	IO_GND
15	PF4	35	MISO_SDA	55	SDO1_PE10	75	IO_VDD
16	PF5	36	SCK_SCL	56	SDO2_SDI3_PC9	76	SCKR_PC0
17	IO_VDD	37	SS_HA2	57	SDO3_SDI2_PC8	77	SCKT_PC3
18	PF1	38	HREQ	58	SDO4_SDI1_PC7	78	FSR_PC1
19	PF0	39	PLLA_VDD	59	SDO5_SDI10_PC6	79	FST_PC4
20	GND	40	PLLA_GND	60	FST_PE4	80	SDO5_SDI10_PC6

PE8001A (MAIN ASSY : IC702)

• DAC IC

• Pin Arrangement (Top view)



• Block Diagram

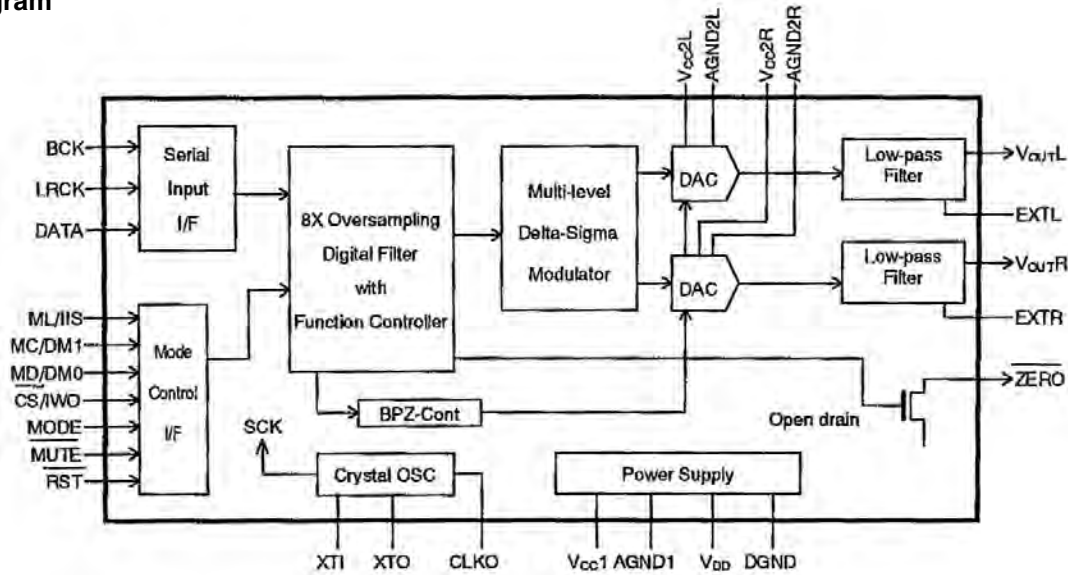

● Pin Function

PIN	NAME	I/O	DESCRIPTIONS
1	LRCK	IN	LRCK Clock Input (f_s). ⁽¹⁾
2	DATA	IN	Serial Audio Data Input. ⁽¹⁾
3	BCK	IN	Bit Clock Input for Serial Audio Data. ⁽¹⁾
4	CLKO	OUT	Buffered Output of System Clock.
5	XTI	IN	Oscillator Input / External Clock Input.
6	XTO	OUT	Oscillator Output.
7	DGND	-	Digital Ground.
8	V _{DD}	-	Digital Power. + 5 V
9	V _{CC2R}	-	Analog Power. + 5 V
10	AGND2R	-	Analog Ground.
11	EXTR	OUT	Rch, Common Pin of Analog Output Amp.
12	NC	-	Non Connection.
13	V _{OUTR}	OUT	Rch, Analog Voltage Output of Audio signal.
14	AGND1	-	Analog Ground.
15	V _{CC1}	-	Analog Power. + 5 V
16	V _{OUTL}	OUT	Lch, Analog Voltage Output of Audio signal.
17	NC	-	Non Connection.
18	EXTL	OUT	Lch, Common Pin of Analog Output Amp
19	AGND2L	-	Analog Ground.
20	V _{CC2L}	-	Analog Power. + 5V
21	ZERO	OUT	Zero Data Flag.
22	RST	IN	Reset. When this pin is LOW, the DF & modulators are held in reset. ⁽²⁾
23	CS / IWO	IN	Chip Select / Input format selection. ⁽³⁾
24	MODE	IN	Mode Control Select. (H: Software, L: Hardware) ⁽²⁾
25	MUTE	IN	Mute Control. ⁽²⁾
26	MD / DM0	IN	Mode Control, Data / De-emphasis selection 1. ⁽²⁾
27	MC / DM1	IN	Mode Control, BCK / De-emphasis selection 2. ⁽²⁾
28	ML / IIS	IN	Mode Control, WDCK / Input format selection. ⁽²⁾

8pt:

- (1) Pins 1, 2, 3: Schmitt-trigger input.
 (2) Pins 22, 24, 25, 26, 27, 28: Schmitt-trigger input with internal pull-up.
 (3) Pin 23: Schmitt-trigger input with internal pull-down.

8. PANEL FACILITIES

8.1 PANEL FACILITIES

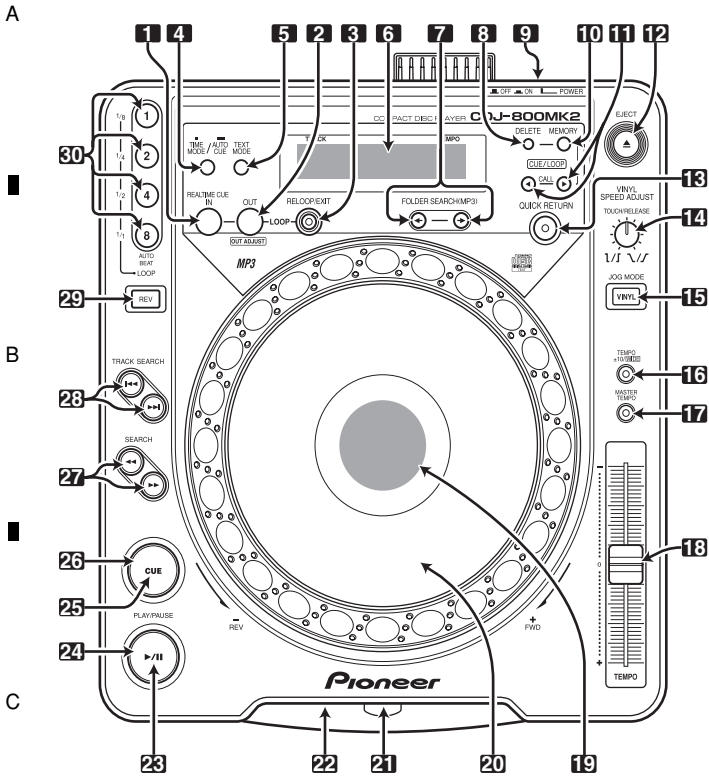

- 8. CUE/LOOP DELETE button**
Use to delete cue points and loop points from internal memory.
- 9. POWER OFF /ON switch**
This switch is located on the rear panel of the unit.
- 10. CUE/LOOP MEMORY button**
Use to record cue points and loop points to internal memory .
- 11. CUE/LOOP CALL buttons (,)**
Use to call cue points and loop points recorded in internal memory.
- 12. EJECT button ()**
When button is pressed, disc rotation stops and disc is ejected from port.
- 13. QUICK RETURN button/indicator**
If this switch is set to ON when the JOG MODE is set to [VINYL], pressing the surface of the Jog dial will cause play to return quickly to the cue point.
- 14. VINYL SPEED ADJUST TOUCH/RELEASE dial**
This dial control is used to adjust the deceleration speed from play to full stop when the JOG MODE is set to [VINYL] and the jog dial surface is pressed, and also the acceleration speed from full stop to play when the user's finger is removed from the surface of the jog dial.
- 15. JOG MODE VINYL button/indicator**
VINYL mode: The button indicator lights. When the surface of the jog dial is pressed during playback, play stops, and if the jog dial is then rotated, sound is produced in accordance with the degree of rotation.
• The currently set jog mode is stored in memory even when power is turned off.
CDJ mode: The above action does not occur when the jog dial is pressed.
- 16. TEMPO control range selector button/indicator (TEMPO ± 10 /WIDE)**
Each time the button is pressed, the variable range of the TEMPO adjust slider alternates (± 10 %/WIDE). The button lights when [WIDE] is selected.
• When playing CDs, the variable during [WIDE] selection is ± 100 %; when playing MP3, the variable range with [WIDE] is ± 16 %.
- 17. MASTER TEMPO button/indicator**
When pressed, the master tempo function alter nates ON/OFF.
- 18. TEMPO adjust slider**
When moved toward the user (+ front), the track tempo increases, and when moved away from the user (- rear), the tempo decreases.
- 19. Jog dial display**
- 20. Jog dial (+FWD/-REV)**
- 21. Disc loading slot**
- 22. Forced eject hole**
- 23. Play/pause indicator ()**
Lights during playback, and flashes during pause mode.
- 24. PLAY/PAUSE button ()**
- 25. CUE indicator**
Lights when a Cue point is set. Flashes in pause mode.
- 26. CUE button**
Cue point setting
Back cue
Cue point sampler
- 27. SEARCH buttons (,)**

- 1. LOOP IN/REALTIME CUE button/indicator**
Realtime cue
Loop-in point input
- 2. LOOP OUT (OUT ADJUST) button/indicator**
Loop-out point input
Loop-out point adjust
- 3. RELOOP/EXIT button/indicator**
- 4. TIME MODE/AUTO CUE button**
TIME MODE:
Each time the button is pressed, the display's time display alternates between the current elapsed play time and the remaining play time (REMAIN).
When playing MP3, the **REMAIN** time may not display immediately, depending on the track.
• The current **TIME MODE** setting is retained in memory even when the power is turned off.
AUTO CUE:
When the button is held depressed for 1 second or more, the AUTO CUE mode is alternately enabled and disabled.
When the button is held depressed for 5 seconds or more, the AUTO CUE level is toggled.
• The current AUTO CUE on/off and AUTO CUE level settings are retained in memory even when power is turned off.
- 5. TEXT MODE button**
When this button is pressed, the TEXT display mode is enabled, and each additional time the button is pressed, the display alternates between track name, album name, and artist name.
• To set to time display, press the **TIME MODE/AUTO CUE** button.
- 6. Display**
- 7. FOLDER SEARCH buttons (,)**
During MP3 playback, layered CD-ROM folder search will be performed in the designated direction.

28. TRACK SEARCH buttons (◀◀, ▶▶)

29. Reverse button / indicator (REV)

When this button is pressed, its indicator lights and the unit is set to reverse play.

30. AUTO BEAT LOOP buttons / indicators (1, 2, 4, 8)

(1/8, 1/4, 1/2, 1/1)

When this button is pressed, auto loop play is performed based on the track's BPM (1 beat, 2 beats, 4 beats or 8 beats).

When a loop has been set manually, the button operates as a loop shortening button. (1=1/8, 2=1/4, 4=1/2, 8=1/1).

Rear Panel

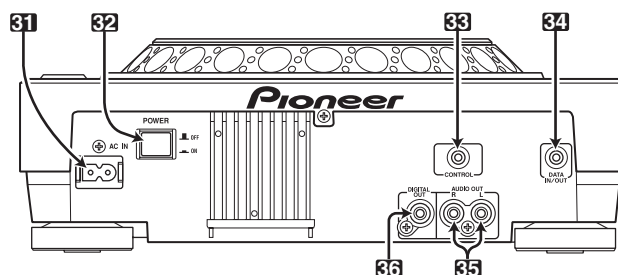

31. AC inlet (AC IN)

Use the accessory power cord to connect this inlet to a standard AC power outlet.

32. POWER OFF/ON switch

33. CONTROL connector

When the accessory control cord is used to connect this connector to the corresponding CONTROL connector on a Pioneer DJ mixer, the DJ mixer can be used to control the CD player for fader start play and back cue.

Also, by connecting this connector to the CONTROL connector on another Pioneer DJ CD player, automatic relay play can be performed.

34. DATA IN/OUT connector

When a commercially available miniplug cord (or the accessory control cord) is used to connect this jack to the same jack on another CDJ-800MK2, recorded data such as cue points and loop points can be copied from one player to the other.

35. AUDIO OUT L, R connectors

RCA-type analog audio output jacks.

36. DIGITAL OUT connector

RCA type coaxial digital output connectors used to connect a DJ mixer or AV amplifier, CD player, etc., equipped with digital input connectors. The digital outputs here support all DJ and other functions, but only audio data is output (without subcodes; CD graphics are not supported).

Display Section

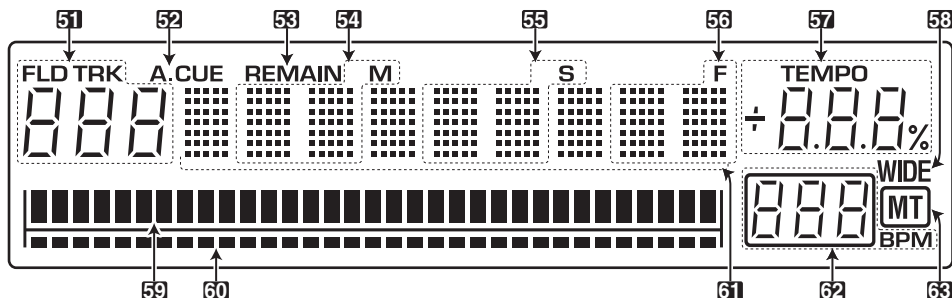

51. Track number/folder number display (TRK/FLD)

When playing an audio CD, the [TRK] indicator lights, and the two-digit track number appears (01 to 99).

When playing MP3, [TRK] lights and the track number is displayed in three digits (01 to 999). During folder search, the [FLD] indicator lights, and a two-digit folder number is displayed (00 to 99).

52. Auto cue indicator (A.CUE)

Lights when auto cue is ON.

53. REMAIN indicator

This indicator lights to indicate that track's remaining time is being displayed.

54. Time (minutes) display (M)

55. Time (seconds) display (S)

56. Frame display (F)

Seventy-five frames equal one second.

57. TEMPO display

Displays change in playing speed (tempo) caused by movement of the TEMPO adjust slider.

58. Tempo control range display (WIDE)

Lights when TEMPO ± 10 /WIDE button is set to [WIDE].

59. Playing address display

Toprovided a quick grasp of the current track's elapsed time and remaining playing time, the entire track is shown as a bar graph scaled over the entire width of the display.

- During elapsed time display, the bar graph's indicator segments turn on from left to right.
- During remaining time display, the bar graph indicator segments turn off from left to right.
- When a track has less than 30 seconds of remaining play time, the graph flashes slowly; when less than 15 seconds remain, the flashing becomes quicker.

60. Memory point display

If cue memory or loop memory has been recorded in the currently playing track, its relative starting position is displayed here.

61. Dot matrix display (7x5 dots by 9 segments)

The dot matrix is used to display TEXT, guides and other information. Text up to 48 characters can be displayed (text longer than 8 characters is scrolled).

62. BPM display (0 to 360 BPM)

This display shows the Beats-Per-Minute (BPM) of the currently playing track (detection range 70 to 180 BPM). The automatic BPM counter may be unable to compute the correct BPM for some tracks.

63. Master tempo indicator (MT)

Lights when the master tempo function is ON.

Jog dial display

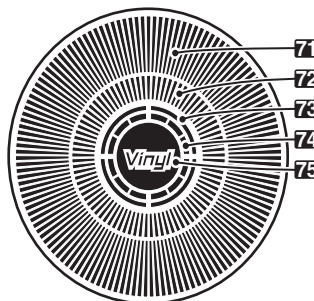

71. Operation display

This display shows the relative playing position, with one revolution equivalent to 135 frames. During playback, the display rotates, and it stops during pause mode.

72. Cue point position indicator

Indicates position of cue points.

73. Audio memory status indicator

This indicator flashes during audio memory write, and lights when writing has been sufficiently completed. When the indicator is flashing, it may not be possible to record real time cue points. The indicator also flashes when memory insufficiency occurs due to scratch operation.

74. Jog touch detection indicator

In VINYL mode, this indicator lights to indicate that the jog dial surface has been touched.

75. VINYL mode indicator

Lights during VINYL mode.

■

5

■

6

■

7

■

8

■

A

■

B

■

C

■

D

■

E

■

F

■

5

■

6

CDJ-800MK2

■

7

■

8

■

■ Lubricants and Glues list



Name	Lubricants and Glues No.	Remark
Dyefree	GEM1036 (ZLX-ME413A)	Refer to "2.4 SLOT-IN MECHANISM SECTION"
Grease	GYA1001 (ZLB-PN397B)	Refer to "2.3 CONTROL PANEL SECTION", "2.4 SLOT-IN MECHANISM SECTION"
Grease	GYA1007 (ZLB-PN348P)	Refer to "2.4 SLOT-IN MECHANISM SECTION", "2.3 CONTROL PANEL SECTION"

B

■ Cleaning



• Before shipping out the product, be sure to clean the following positions by using the prescribed cleaning tools:

Position to be cleaned	Cleaning tools	Remark
Pickup lenses	Cleaning liquid : GEM1004 Cleaning paper : GED-008	Refer to "2.4 SLOT-IN MECHANISM SECTION", "7.1.5 DISASSEMBLY SECTION".

C

D

E

F