

Pioneer

Service Manual

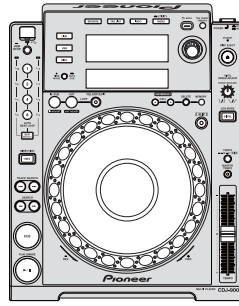

CDJ-900

ORDER NO.
RRV4000

MULTI PLAYER

CDJ-900

THIS MANUAL IS APPLICABLE TO THE FOLLOWING MODEL(S) AND TYPE(S).

Model	Type	Power Requirement	Remarks
CDJ-900	CUXJ	AC 120 V	
CDJ-900	SYXJ8	AC 220 V to 240 V	
CDJ-900	FLXJ	AC 110 V to 240 V	
CDJ-900	KXJ5	AC 220 V to 240 V	
CDJ-900	AXJ5	AC 220 V	



For details, refer to "Important Check Points for good servicing".

PIONEER CORPORATION 4-1, Meguro 1-chome, Meguro-ku, Tokyo 153-8654, Japan
PIONEER ELECTRONICS (USA) INC. P.O. Box 1760, Long Beach, CA 90801-1760, U.S.A.
PIONEER EUROPE NV Haven 1087, Keetberglaan 1, 9120 Melsele, Belgium
PIONEER ELECTRONICS ASIACENTRE PTE. LTD. 253 Alexandra Road, #04-01, Singapore 159936
©PIONEER CORPORATION 2009

K-IZE OCT. 2009 Printed in Japan

SAFETY INFORMATION

A



This service manual is intended for qualified service technicians ; it is not meant for the casual do-it-yourselfer. Qualified technicians have the necessary test equipment and tools, and have been trained to properly and safely repair complex products such as those covered by this manual.

Improperly performed repairs can adversely affect the safety and reliability of the product and may void the warranty. If you are not qualified to perform the repair of this product properly and safely, you should not risk trying to do so and refer the repair to a qualified service technician.

WARNING

B

This product may contain a chemical known to the State of California to cause cancer, or birth defects or other reproductive harm.

Health & Safety Code Section 25249.6 - Proposition 65

C

D

IMPORTANT

THIS PIONEER APPARATUS CONTAINS LASER OF CLASS 1. SERVICING OPERATION OF THE APPARATUS SHOULD BE DONE BY A SPECIALLY INSTRUCTED PERSON.

Laser Pickup specifications and Laser characteristics

For CD Wave length (typ) : 790 nm
 Operation output : 4 mW CW, Class 1
 Maximum output : Class 1 (Under fault condition)

E

Additional Laser Caution

1. Laser Interlock Mechanism
The position of the switch (S8902) for detecting loading completion is detected by the system microprocessor, and the design prevents laser diode oscillation when the switch is not in LPS1 terminal side (when the mechanism is not clamped and LPS1 signal is high level.)
Thus, the interlock will no longer function if the switch is deliberately set to LPS1 terminal side.
(if LPS1 signal is low level).
In the test mode * the interlock mechanism will not function.
Laser diode oscillation will continue, if pin 5 of AN22022A (IC7004) on the SRV Assy is connected to GND, or else the terminals of Q7002 are shorted to each other (fault condition).
2. When the cover is opened, close viewing of the objective lens with the naked eye will cause exposure to a Class 1 laser beam.

F

LABEL CHECK

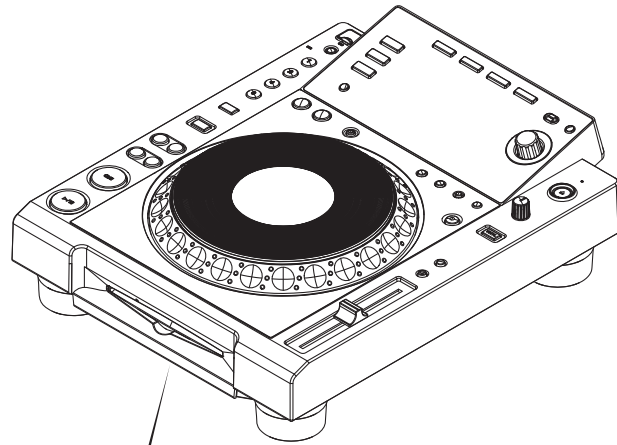

(Printed on the bottom plate)

CLASS 1 LASER PRODUCT
APPAREIL À LASER DE CLASSE 1

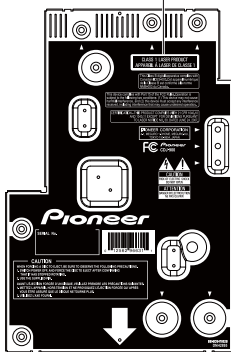

CUXJ

(Printed on the bottom plate)

CLASS 1 LASER PRODUCT
APPAREIL À LASER DE CLASSE 1

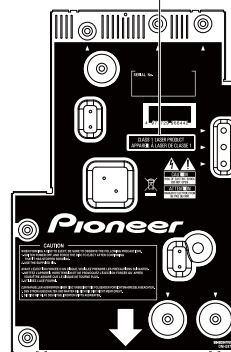

SYXJ8

(Printed on the bottom plate)

CLASS 1 LASER PRODUCT

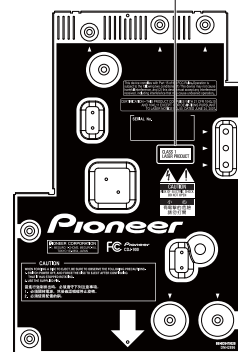

FLXJ

(Printed on the bottom plate)

CLASS 1 LASER PRODUCT
클래스 1 레이저 제품

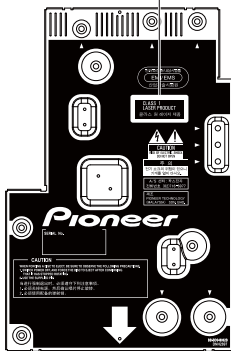

KXJ5

(Printed on the bottom plate)

CLASS 1 LASER PRODUCT
1类激光产品

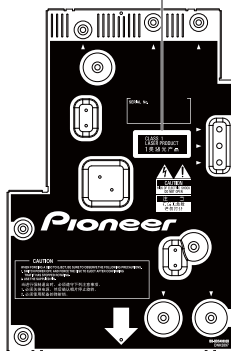

AXJ5

[Important Check Points for Good Servicing]

In this manual, procedures that must be performed during repairs are marked with the below symbol. Please be sure to confirm and follow these procedures.

1. Product safety



Please conform to product regulations (such as safety and radiation regulations), and maintain a safe servicing environment by following the safety instructions described in this manual.

- ① Use specified parts for repair.

Use genuine parts. Be sure to use important parts for safety.

- ② Do not perform modifications without proper instructions.

Please follow the specified safety methods when modification (addition/change of parts) is required due to interferences such as radio/TV interference and foreign noise.

- ③ Make sure the soldering of repaired locations is properly performed.

When you solder while repairing, please be sure that there are no cold solder and other debris. Soldering should be finished with the proper quantity. (Refer to the example)

- ④ Make sure the screws are tightly fastened.

Please be sure that all screws are fastened, and that there are no loose screws.

- ⑤ Make sure each connectors are correctly inserted.

Please be sure that all connectors are inserted, and that there are no imperfect insertion.

- ⑥ Make sure the wiring cables are set to their original state.

Please replace the wiring and cables to the original state after repairs. In addition, be sure that there are no pinched wires, etc.

- ⑦ Make sure screws and soldering scraps do not remain inside the product.

Please check that neither solder debris nor screws remain inside the product.

- ⑧ There should be no semi-broken wires, scratches, melting, etc. on the coating of the power cord.

Damaged power cords may lead to fire accidents, so please be sure that there are no damages. If you find a damaged power cord, please exchange it with a suitable one.

- ⑨ There should be no spark traces or similar marks on the power plug.

When spark traces or similar marks are found on the power supply plug, please check the connection and advise on secure connections and suitable usage. Please exchange the power cord if necessary.

- ⑩ Safe environment should be secured during servicing.

When you perform repairs, please pay attention to static electricity, furniture, household articles, etc. in order to prevent injuries. Please pay attention to your surroundings and repair safely.

2. Adjustments



To keep the original performance of the products, optimum adjustments and confirmation of characteristics within specification. Adjustments should be performed in accordance with the procedures/instructions described in this manual.

3. Lubricants, Glues, and Replacement parts



Use grease and adhesives that are equal to the specified substance. Make sure the proper amount is applied.

4. Cleaning



For parts that require cleaning, such as optical pickups, tape deck heads, lenses and mirrors used in projection monitors, proper cleaning should be performed to restore their performances.

5. Shipping mode and Shipping screws



To protect products from damages or failures during transit, the shipping mode should be set or the shipping screws should be installed before shipment. Please be sure to follow this method especially if it is specified in this manual.

CONTENTS

SAFETY INFORMATION.....	2	
1. SERVICE PRECAUTIONS.....	6	
1.1 NOTES ON SOLDERING.....	6	A
1.2 NOTES ON FLASH ROM.....	6	
1.3 NOTES ON PANEL CPU AND GUI CPU.....	6	
1.4 NOTES ON LINK CONNECTOR.....	7	
1.5 REPAIR OF THE JACB ASSY.....	7	
2. SPECIFICATIONS.....	8	
2.1 SPECIFICATIONS.....	8	
2.2 DISCS / FILES PLAYABLE.....	9	
2.3 PANEL FACILITIES.....	11	
3. BASIC ITEMS FOR SERVICE.....	14	
3.1 CHECK POINTS AFTER SERVICING.....	14	
3.2 PCB LOCATIONS.....	15	
3.3 JIGS LIST.....	17	B
4. BLOCK DIAGRAM.....	18	
4.1 OVERALL WIRING DIAGRAM.....	18	
4.2 SIGNAL BLOCK DIAGRAM.....	20	
4.3 POWER SUPPLY BLOCK DIAGRAM.....	22	
5. DIAGNOSIS.....	24	
5.1 POWER ON SEQUENCE.....	24	
5.2 TROUBLESHOOTING.....	26	
5.3 FAILURE JUDGEMENT OF THE PICKUP ASSY.....	39	
5.4 CONNECTION CHECK WITH THE PC.....	40	
6. SERVICE MODE.....	41	
6.1 OUTLINE OF THE SERVICE MODE.....	41	
6.2 ABOUT THE DEVICE OF CDJ-900.....	41	C
6.3 DETAILS ON SERVICE MODE.....	42	
7. DISASSEMBLY.....	55	
8. EACH SETTING AND ADJUSTMENT.....	66	
8.1 JOG DIAL ROTATION LOAD ADJUSTMENT.....	66	
8.2 ITEMS FOR WHICH USERS SETTING IS AVAILABLE.....	67	
8.3 UPDATING OF THE FIRMWARE AND RECOVERY.....	67	
9. EXPLODED VIEWS AND PARTS LIST.....	68	
9.1 PACKING SECTION.....	68	
9.2 EXTERIOR SECTION.....	70	
9.3 CONTROL PANEL SECTION.....	72	
9.4 JOG DIAL SECTION.....	74	
9.5 SLOTIN MECHA SECTION.....	76	
10. SCHEMATIC DIAGRAM.....	78	D
10.1 SRV ASSY (1/2).....	78	
10.2 SRV ASSY (2/2) and SLMB ASSY.....	80	
10.3 MAIN ASSY (1/3).....	82	
10.4 MAIN ASSY (2/3).....	88	
10.5 MAIN ASSY (3/3) and USBA ASSY.....	94	
10.6 JACB ASSY.....	96	
10.7 DFLB and ENCB ASSYS.....	98	
10.8 KSWB ASSY.....	100	
10.9 SLDB ASSY.....	102	
10.10 BFLB ASSY.....	104	
10.11 MSWB ASSY.....	106	
10.12 JOGB ASSY.....	107	E
10.13 JFLB ASSY.....	108	
10.14 POWER SUPPLY and ACIN ASSYS.....	110	
10.15 WAVEFORMS.....	112	
11. PCB CONNECTION DIAGRAM.....	116	
11.1 SRV and SLMB ASSYS.....	116	
11.2 MAIN ASSY.....	120	
11.3 USBA and JACKB ASSYS.....	124	
11.4 DFLB and ENCB ASSYS.....	126	
11.5 KSWB and SLDB ASSYS.....	130	
11.6 BFLB and MSWB ASSYS.....	134	
11.7 JOGB and JFLB ASSYS.....	136	
11.8 POWER SUPPLY and ACIN ASSYS.....	138	
12. PCB PARTS LIST.....	140	F

1. SERVICE PRECAUTIONS

1.1 NOTES ON SOLDERING

- A
- For environmental protection, lead-free solder is used on the printed circuit boards mounted in this unit.
Be sure to use lead-free solder and a soldering iron that can meet specifications for use with lead-free solders for repairs accompanied by reworking of soldering.
 - Compared with conventional eutectic solders, lead-free solders have higher melting points, by approximately 40 °C. Therefore, for lead-free soldering, the tip temperature of a soldering iron must be set to around 373 °C in general, although the temperature depends on the heat capacity of the PC board on which reworking is required and the weight of the tip of the soldering iron.

Do NOT use a soldering iron whose tip temperature cannot be controlled.

- B
- Compared with eutectic solders, lead-free solders have higher bond strengths but slower wetting times and higher melting temperatures (hard to melt/easy to harden).

The following lead-free solders are available as service parts:

- Parts numbers of lead-free solder:
GYP1006 1.0 in dia.
GYP1007 0.6 in dia.
GYP1008 0.3 in dia.

C

1.2 NOTES ON FLASH ROM

NEVER replace the FLASH ROM (IC114) on the MAIN Assy during servicing.
If the FLASH ROM is assumed to be defective, replace the whole MAIN Assy.
This FLASH ROM contains data that can only be written in at the factory.
An IEEE 802.3-based MAC address specific to this unit has been written.

D

1.3 NOTES ON PANEL CPU AND GUI CPU

- E
- After the PANEL CPU (IC8005) or GUI CPU (IC4002) is replaced, update its program.
The built-in PANEL CPU and GUI CPU contains a FLASH ROM and will not operate without a program.
For updating, proceed as follows:
1. Insert the USB flash memory device that contains the program.
 2. While holding the USB STOP key pressed, turn on the unit.
Hold the USB STOP key pressed until the "Pioneer" logo disappears.
 3. Updating starts.

F

1.4 NOTES ON LINK CONNECTOR

If the LINK connector (JA1301) is replaced during a repair of the MAIN Assy, detach the ID LABEL (AXW7015) from the old connector then attach it to the new connector.
As an IEEE 802.3-based MAC address specific to this unit has been printed on the ID LABEL (AXW7015) be sure to attach it.

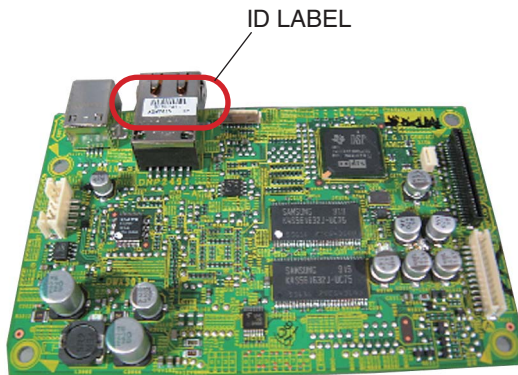

MAIN Assy

1.5 REPAIR OF THE JACB ASSY

When repairing the JACB Assy, note the following:

On part of the initial-lot JACB Assy, the DCN1186 (470 ohms, Part description No. 471) is mounted as the resistors (R8820–8823, 8839–8844, 8855, and 8856). In such a case, mount a new DCN1186 during replacement. (See the section 10.6 JACB ASSY.)

This applies only to the initial-lot products for the destinations SYXJ8 and FLXJ.

For products for other destinations, replace with the DCN1185 (330 ohms, Part description No. 331), as described in the circuit diagram.

2.2 DISCS / FILES PLAYABLE

Playable discs

Discs including the following marks on the disc label, package or jacket can be played.

Types of discs that can be played and marks



CD



CD-TEXT



CD-R



CD-RW

Discs playable on this player are as shown below.

- CD-R/-RW discs recorded in music CD (CD-DA) format
- CD-R/-RW disc containing music files (MP3/AAC/WAV/AIFF)

❖ Discs that cannot be played

- DTS-CD
- Photo CDs
- Video CDs
- CD Graphics (CD-G) discs
- Unfinalized CDs
- DVD-R/-RW
- DVD+R/+RW
- DVD-R DL (dual layer)
- DVD+R DL (dual layer)
- DVD-Video discs
- DVD-Audio discs
- DVD-RAM discs
- DualDisc

❖ Playback of discs created on a computer

Depending on the application's settings and the computer's environment settings, it may not be possible to play discs created on a computer. Record discs in a format playable on the CDJ-900. For details, contact your application's selling agent.

It may not be possible to play discs created on a computer due to the disc's properties, scratches or dirt, or poor recording quality (dirt on the recording lens, etc.).

❖ Creating backup discs

When CD-R/-RW discs are paused or left in the pause mode at cue points for long periods of time, it may become difficult to play the disc at that point, due to the properties of the disc. Also, when a specific point is looped repeatedly an extremely large number of times, it may become difficult to play that point.

When playing valuable discs, we recommend making backup discs.

❖ Regarding copy protected CDs

This player is designed to conform to the specifications of the audio CD format. This player does not support the playback or function of discs that do not conform to these specifications.

❖ About 8 cm single CDs

8 cm single CDs cannot be played on the CDJ-900. Do not mount 8 cm adapters on CDs and play them on the CDJ-900. The adapter could fall off as the disc spins, damaging the disc or the player.

❖ About CD-Text

The CDJ-900 supports CD-Text. Titles, album names and artist names recorded in CD-Text are displayed. When multiple text data is recorded, the first text data is displayed. The supported character codes are shown below.

- ASCII
- ISO-8859
- MS-JIS
- Mandarin Chinese character code

About CD playback

Music files (MP3/AAC/WAV/AIFF) recorded on CD-R/-RW discs can be played.

Folder layers	Max. 8 levels (files in folders beyond the 8th level cannot be played)
Max. number of folders	2 000 folders per disc (folders beyond the 2 000th folder cannot be displayed)
Max. number of files	<ul style="list-style-type: none"> • 999 files for each file format • 3 000 files per disc (files beyond the 3 000th folder cannot be displayed)

When there are many folders or files, some time may be required for loading.

A

About USB devices

Music files (MP3/AAC/WAV/AIFF) recorded on USB devices can be played. Such data as disc identification information, cue points, loop points and hot cues can be recorded on USB devices.

Folder layers	Max. 8 levels (files in folders beyond the 8th level cannot be played)
Max. number of folders	Unlimited (folders beyond the 10 000th folder within a single folder cannot be displayed)
Max. number of files	Unlimited (files beyond the 10 000th file within a single folder cannot be displayed)
Supported file systems	FAT, FAT32 and HFS+

B

- The CDJ-900 supports such USB mass storage class USB devices as external hard discs, portable flash memory drives and digital audio players. External DVD/CD drives and other optical disc devices cannot be used.
- When there are many folders or files, some time may be required for loading.
- If multiple partitions are set for the USB device, the device may not be recognized.

❖ Cautions on using USB devices

- Some USB devices may not operate properly. Please note that Pioneer will accept no responsibility whatsoever for loss of data recorded on USB devices.
- USB hubs cannot be used.
- USB devices equipped with flash card readers may not operate.
- If a current above the allowable level is detected in the CDJ-900's USB port, it could happen that a warning message is displayed, the power to the USB device is cut off and signal transfer is stopped. To restore normal operation, remove USB devices connected to the player, then press **USB STOP**. Avoid reusing the USB device for which the excess current was detected. If normal operation is not restored after performing the above operation (if signals are not transferred), try turning off the player's power then turning it back on.
- Depending on the USB device you are using, the desired performance may not be achieved.

C

About MP3 files

MP3 files can have a constant bit rate (CBR) or a variable bit rate (VBR). Both types of files can be played on the CDJ-900, but the search and super fast search functions are slower with VBR files. If your priority is operability, we recommend recording MP3 files in CBR.

The CDJ-900 supports MP3 files in the formats shown below.

Compatible formats	MPEG-1	Audio Layer-3 sampling frequencies of 32 kHz, 44.1 kHz and 48 kHz, and bit rates of 32 kbps – 320 kbps are supported.
	MPEG-2	Audio Layer-3 sampling frequencies of 16 kHz, 22.05 kHz and 24 kHz, and bit rates of 16 kbps – 160 kbps are supported.
Track information	ID3 tag versions 1.0, 1.1, 2.2, 2.3 and 2.4 are supported. Titles, album names, artist names, etc., are displayed here.	
File extension	.mp3	

D

E

F

About AAC files

- AAC is the abbreviation of "Advanced Audio Coding", a basic format of audio compression technology used for MPEG-2 and MPEG-4.
- The file format and extension of AAC data depends on the application used to create the data.
- In addition to AAC files encoded with iTunes® and with the extension ".m4a", files with the extensions ".aac" and ".mp4" can also be played on the CDJ-900. However, copyright protected AAC files purchased for example at the iTunes Music Store cannot be played. Also, some files may not be playable, depending on the iTunes version used to encode them.
- The CDJ-900 supports AAC files in the formats shown below.

Compatible formats	MPEG-4 AAC LC	Sampling frequencies of 16 kHz, 22.05 kHz, 24 kHz, 32 kHz, 44.1 kHz and 48 kHz, and bit rates of 16 kbps – 320 kbps are supported.
Track information	aac	ID3 tag versions 1.0, 1.1, 2.2, 2.3 and 2.4 are supported. Titles, album names, artist names, etc., are displayed here.
	Extensions other than aac	Meta tags (embedded tags) are supported. Titles, album names, artist names, etc., are displayed here.
File extension	.m4a, .aac and .mp4	

About WAV files

The CDJ-900 supports WAV files in the formats shown below.

Compatible formats	The 16-/24-bit non-compressed PCM format and sampling frequencies of 44.1 kHz and 48 kHz are supported.	
Track information	LST chunk Titles, album names, artist names, etc., are displayed here.	
File extension	.wav	

About AIFF files

The CDJ-900 supports AIFF files in the formats shown below.

Compatible formats	The 16-/24-bit non-compressed PCM format and sampling frequencies of 44.1 kHz and 48 kHz are supported. Titles, album names, artist names, etc., are displayed here.	
File extension	.aif, .aiff	

About rekordbox

- rekordbox is an application for managing music files which are used for DJ play with a Pioneer DJ Player (i.e. CDJ-2000, CDJ-900). Data that has been detected and measured, as well as any points which have been set and stored using rekordbox, can be used in combination with a Pioneer DJ Player (i.e. CDJ-2000, CDJ-900) to achieve outstanding DJ performance.
- Install rekordbox from the included CD-ROM onto a computer.

2.3 PANEL FACILITIES

Control Panel

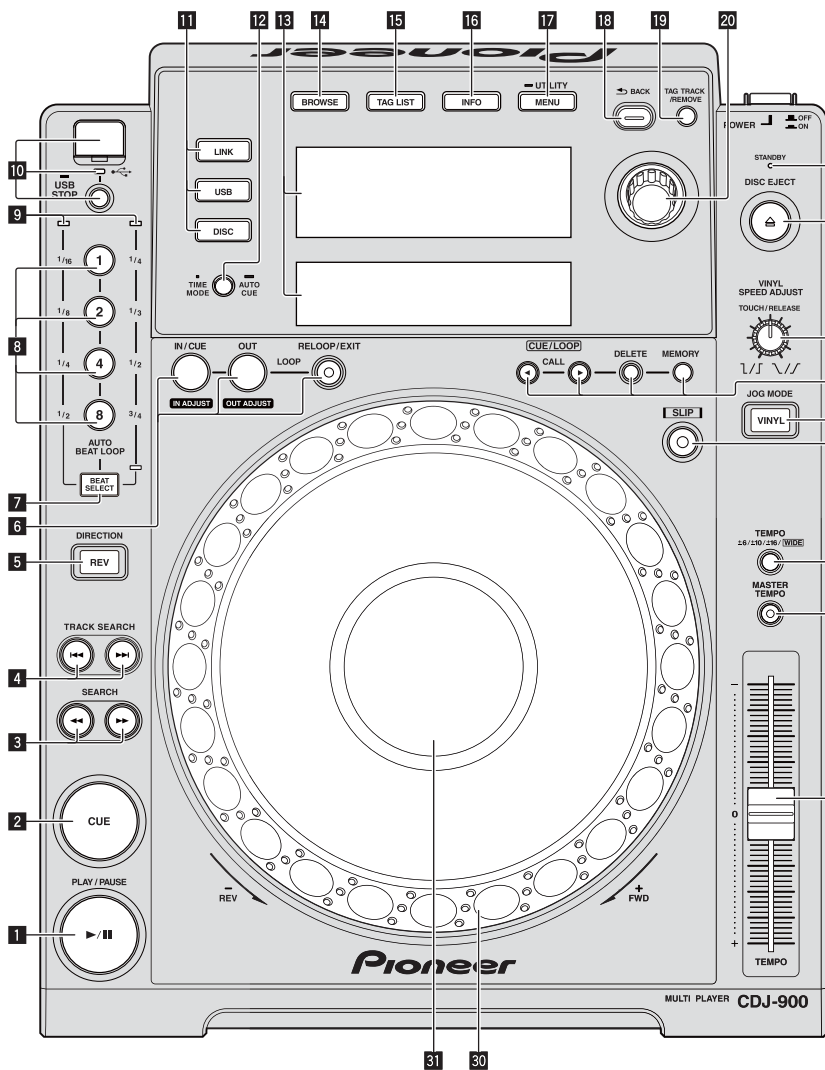

Control Panel

- 1** **PLAY/PAUSE▶/|| and PLAY/PAUSE▶/|| indicator**
This lights when playing tracks and flashes when in the pause mode.
- 2** **CUE and CUE indicator**
This lights when a cue point is set (except during track searching), and flashes when a new cue point can be set in the pause mode.
- 3** **SEARCH◀◀/▶▶**
- 4** **TRACK SEARCH◀◀/▶▶**
- 5** **DIRECTION REV and REV indicator**
- 6** **LOOP IN/CUE (IN ADJUST), LOOP OUT (OUT ADJUST), RELOOP/EXIT**
- 7** **BEAT SELECT**
- 8** **AUTO BEAT LOOP (1, 2, 4, 8)**
- 9** **Beat select indicator**
The indicator for the row selected by pressing [BEAT SELECT] lights.
- 10** **USB device insertion slot, USB indicator and USB STOP**
- 11** **LINK, USB, DISC**

- 12** **TIME MODE/AUTO CUE**
- 13** **Main unit display**
- 14** **BROWSE**
- 15** **TAG LIST**
- 16** **INFO**
- 17** **MENU/UTILITY**
- 18** **BACK**
- 19** **TAG TRACK/REMOVE**
- 20** **Rotary selector**
When selecting tracks or setting items, the cursor moves when the rotary selector is turned. Press the rotary selector to enter.
- 21** **STANDBY indicator**
This lights when in the standby mode.
- 22** **DISC EJECT▲ and DISC EJECT indicator**
- 23** **VINYL SPEED ADJUST**
- 24** **CUE/LOOP CALL◀/▶, DELETE, MEMORY**

Rear Panel

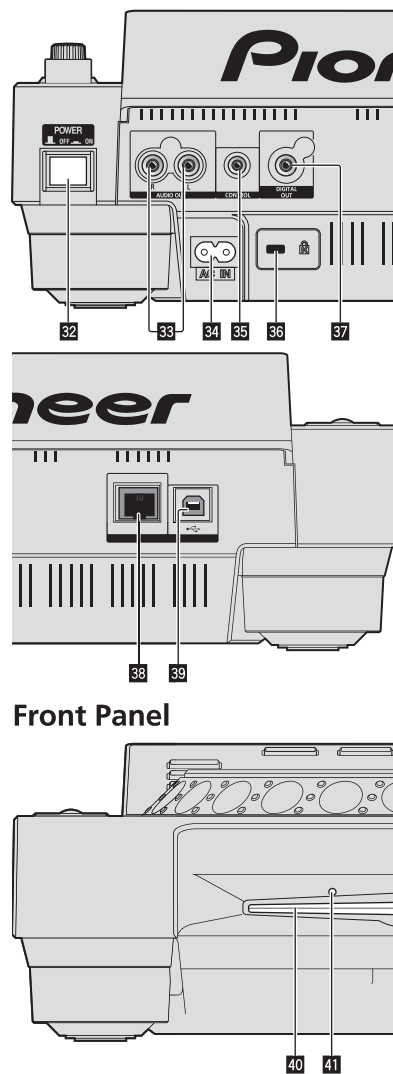

Front Panel

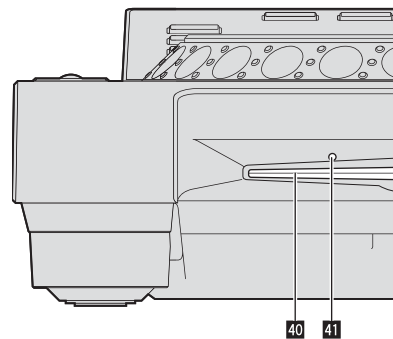

A

25 JOG MODE, VINYL mode indicator and CDJ mode indicator

The mode switches between VINYL and CDJ each time this is pressed. The indicator lights when the VINYL mode is selected.

26 SLIP**27 TEMPO $\pm 6/\pm 10/\pm 16$ /WIDE****28 MASTER TEMPO****29 TEMPO****30 Jog dial (- REV/+ FWD)****31 Jog dial display section**

B

Rear Panel**32 POWER \blacksquare ON \blacksquare OFF**

Press to turn the power on and off.

33 AUDIO OUT L/R**34 AC IN****35 CONTROL****36 Kensington security slot**

C

37 DIGITAL OUT**38 LINK****39 USB**

D

E

F

Front Panel**40 Disc insertion slot****41 Disc force eject pin insertion hole****About ejecting discs by force**

- If the disc cannot be ejected by pressing [DISC EJECT▲], the disc can be ejected forcibly by inserting the disc force eject pin all the way into the disc force eject pin insertion hole on the main unit's front panel.
- When forcibly ejecting a disc, be sure to do so following the procedure below.

1 Press [POWER] and wait at least 1 minute after the set's power has turned off.

Never forcibly eject a disc directly after turning off the set's power. Doing so is dangerous for the reasons described below.

The disc will still be spinning when ejected and could hit your fingers, etc., causing injury.

Also, the disc clamp will rotate in an unstable way, and the disc could get scratched.

2 Use the included disc force eject pin. (Do not use anything else.)

The included disc force eject pin is mounted on the CDJ-900's bottom panel. When the pin is inserted all the way into the insertion hole, the disc is ejected 5 mm to 10 mm out of the disc insertion slot. Grasp the disc with your fingers and pull it out.

Main unit display

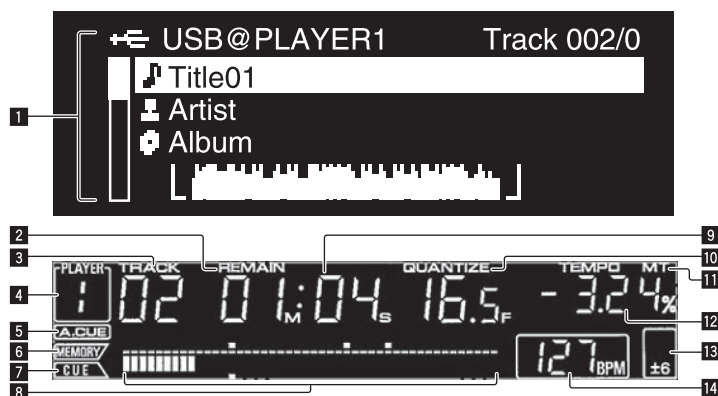

1 Information display section

Up to 63 characters can be displayed for each item. The characters that can be displayed are letters A to Z, numbers 0 to 9 and certain symbols. Any other characters are displayed as "?".

2 REMAIN

This lights when the time display is set to the remaining time.

3 TRACK

This indicates the track number (01 – 99).

4 PLAYER

This indicates the player number (1 – 4) assigned to this CDJ-900.

5 A. CUE

This lights when auto cue is set.

6 MEMORY

Cue and loop points recorded on USB devices are displayed as marks.

7 CUE

The positions of currently set cue and loop points are displayed as marks.

8 Playing address display

The track is displayed as a bar graph. When the remaining time is displayed, the display turns off from the left side. The entire graph flashes slowly when there are less than 30 seconds remaining in the track, then begins flashing rapidly when less than 15 seconds remain.

9 Time display (minutes, seconds and frames)

There are 75 frames to a second.

10 QUANTIZE

This lights red when [QUANTIZE] is turned on. When [QUANTIZE] is turned on, the loop point is automatically set to the beat position nearest the position at which [LOOP IN/CUE (IN ADJUST)], [LOOP OUT (OUT ADJUST)] or [AUTO BEAT LOOP] (1, 2, 4, 8) was pressed. The Quantize function will not work (the indicator is off) under the following conditions:

- When playing tracks recorded on discs
- When playing music files that have not been analyzed with rekordbox
- In the pause mode

11 MT

This lights when the master tempo is set.

12 Playing speed display

The number changes according to the position of [TEMPO].

13 Playing speed adjustment range display

This indicates the range in which the playing speed can be adjusted with respect to the original playing speed recorded on the medium.

14 BPM

Displays BPM (Beats Per Minute) of the track currently being played.

Jog dial display section

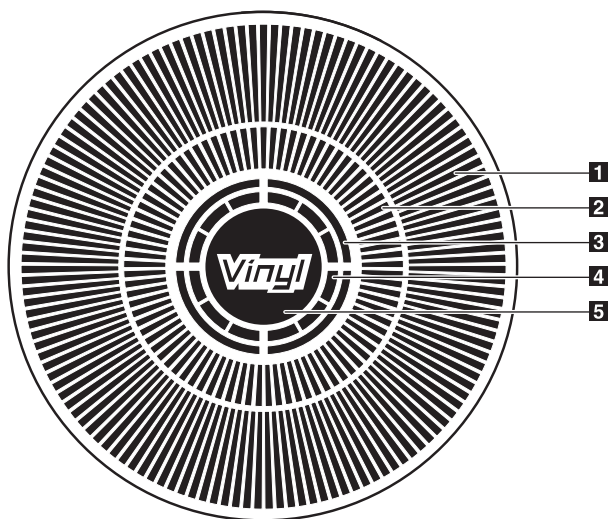

1 Operation display

This indicates the playing position, with one revolution equal to 135 frames. It turns during playback and stops in the pause mode.

2 Cue point display/SLIP play display

3 Audio memory status display

This flashes when the audio memory is being written. It stops flashing, remaining lit, when writing is completed. The operations below may not be possible while the audio memory is being written.

- Setting Cue Point during playback (Real Time Cue)
- The display also flashes when there is not enough memory due to scratch play.

4 Jog touch detection display

When the jog mode is set to VINYL, the top of the jog dial lights when pressed.

5 VINYL

This lights when the jog mode is set to VINYL.

3. BASIC ITEMS FOR SERVICE

3.1 CHECK POINTS AFTER SERVICING

A Items to be checked after servicing / CDJ

To keep the product quality after servicing, confirm recommended check points shown below.

No.	Procedures	Check points
1	Confirm the firmware version on Test Mode.	The version of the firmware must be latest. Update firmware to the latest one, if it is not the latest.
2	Confirm whether the customer complain has been solved. If the customer complain occurs with the specific disc, use it for the operation check.	The customer complain must not be reappeared. Audio and operations must be normal.
3	Play back a CD. (track search)	Audio, Search and operations must be normal.
4	Check the connection of each interface.	
	Play back data contained in the device connected to USB A.	Audio, Search and operations must be normal.
	USB B	The device must be recognized by the PC.
	LINK	The PC must be linked.
5	Check output signals while the JOG dial or TEMPO slider is being operated.	Audio and operations must be normal.
6	Check the keys on the unit.	Check whether a product can be operated properly by buttons on the product.
7	Check the appearance of the product.	No scratches or dirt on its appearance after receiving it for service.

Specific Items to be Checked

No.	Procedures	Check points
1	Confirm playback error rates at the innermost and outermost tracks by using the following disc. CD test disc (STD-905)	The error rates must be less than 3.0×10^{-3} . (This procedure can determine if the drive is degraded.)

See the table below for the items to be checked regarding video and audio.

Item to be checked regarding audio
Distortion
Noise
Volume too low
Volume too high
Volume fluctuating
Sound interrupted

Cleaning



Before shipping out the product, be sure to clean the following positions by using the prescribed cleaning tools.

Position to be cleaned	Name	Part No.	Remarks
Pickup lenses	Cleaning liquid	GEM1004	Refer to "9.5 SLOTIN MECHA SECTION".
	Cleaning paper	GED-008	

3.2 PCB LOCATIONS

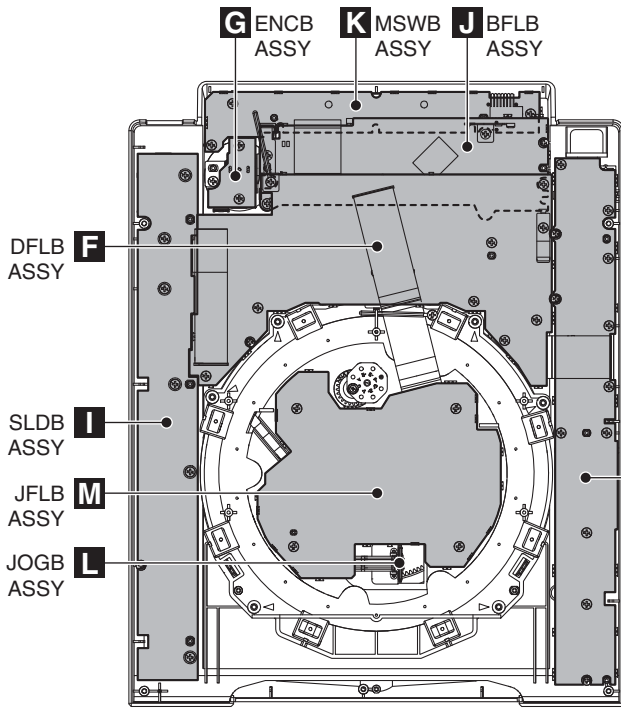

• Bottom view

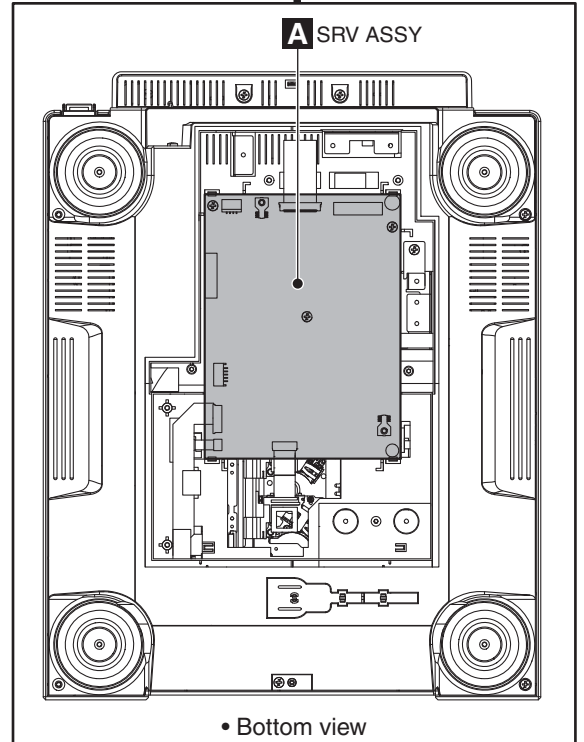
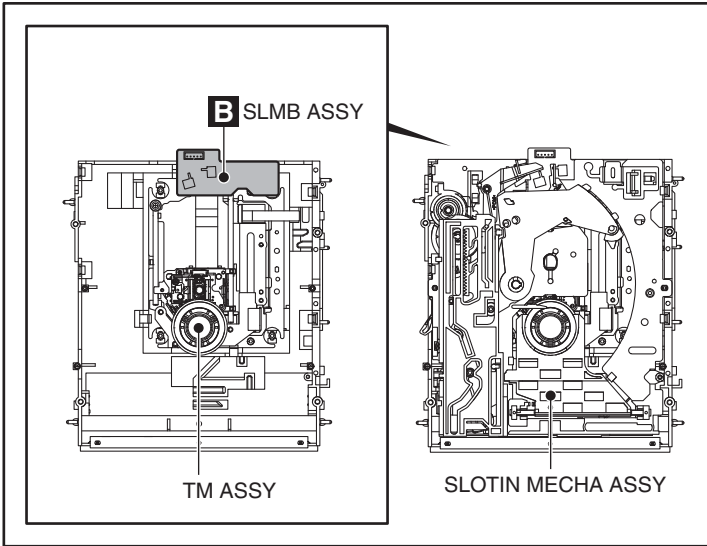
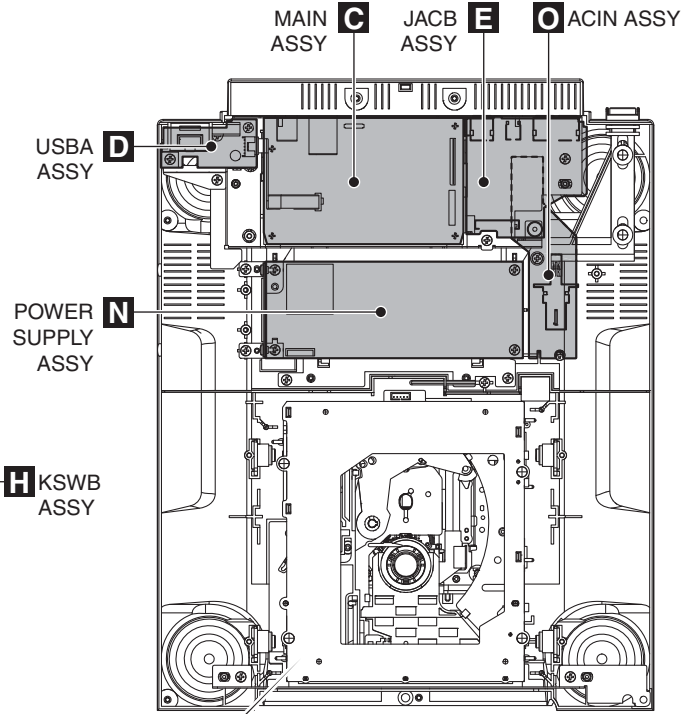

• Bottom view

A

NOTES: ● Parts marked by “NSP” are generally unavailable because they are not in our Master Spare Parts List.
 ● The ⚠ mark found on some component parts indicates the importance of the safety factor of the part.
 Therefore, when replacing, be sure to use parts of identical designation.

LIST OF ASSEMBLIES

Mark	Symbol and Description	CDJ-900 /CUXJ	CDJ-900 /SYXJ8	CDJ-900 /FLXJ	CDJ-900 /KXJ5	CDJ-900 /AXJ5
NSP	1..DFLA ASSY	DWM2361	DWM2361	DWM2361	DWM2361	DWM2361
	2..KSWB ASSY	DWS1416	DWS1416	DWS1416	DWS1416	DWS1416
	2..SLDB ASSY	DWS1417	DWS1417	DWS1417	DWS1417	DWS1417
	2..SLMB ASSY	DWS1418	DWS1418	DWS1418	DWS1418	DWS1418
	2..DFLB ASSY	DWX3021	DWX3021	DWX3021	DWX3021	DWX3021
	2..ENCB ASSY	DWX3022	DWX3022	DWX3022	DWX3022	DWX3022
	2..JACB ASSY	DWX3023	DWX3023	DWX3023	DWX3023	DWX3023
NSP	1..JFLA ASSY	DWM2362	DWM2356	DWM2356	DWM2356	DWM2356
	2..ACIN ASSY	DWR1461	DWR1462	DWR1462	DWR1462	DWR1462
	2..MSWB ASSY	DWS1415	DWS1415	DWS1415	DWS1415	DWS1415
	2..JFLB ASSY	DWX3024	DWX3024	DWX3024	DWX3024	DWX3024
	2..BFLB ASSY	DWX3025	DWX3025	DWX3025	DWX3025	DWX3025
	2..JQGB ASSY	DWX3026	DWX3026	DWX3026	DWX3026	DWX3026
	1..MAIN ASSY	DWX3019	DWX3019	DWX3019	DWX3019	DWX3019
1..SRV ASSY	DWX3020	DWX3020	DWX3020	DWX3020	DWX3020	
1..USBA ASSY	DWX3044	DWX3044	DWX3044	DWX3044	DWX3044	
⚠	1..POWER SUPPLY ASSY	DWR1463	DWR1463	DWR1463	DWR1463	DWR1463
NSP	1..SLOTIN MECHA ASSY	DXA2121	DXA2121	DXA2121	DXA2121	DXA2121
1..TM ASSY 03-S	VXX3125	VXX3125	VXX3125	VXX3125	VXX3125	

E

F

3.3 JIGS LIST

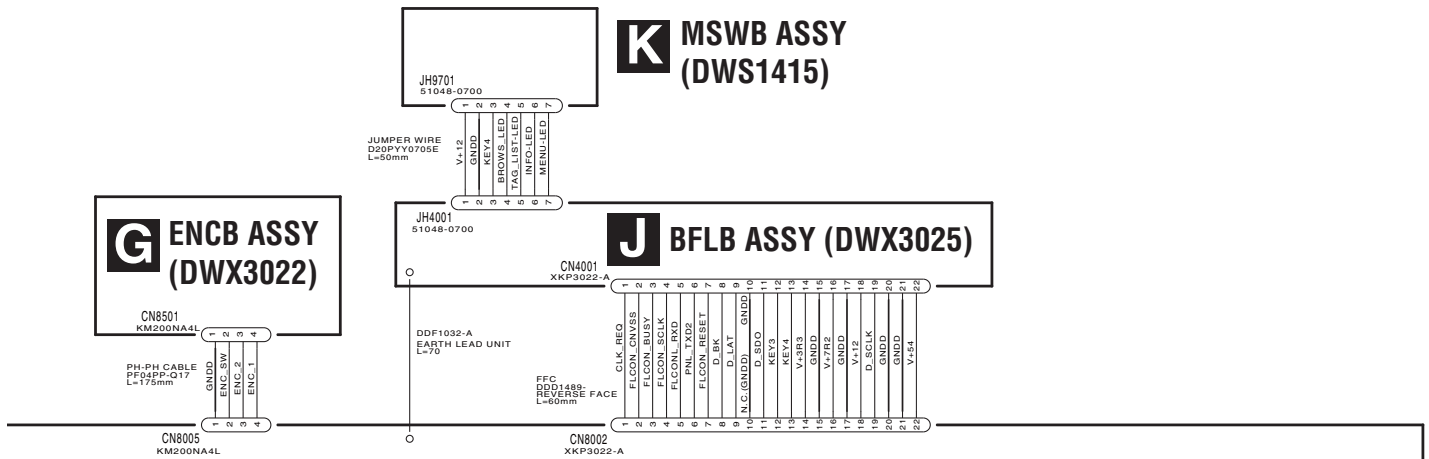

■ Lubricants and Glues List

Name	Part No.	Remarks
Lubricating oil	GYA1001	Refer to "9.4 JOG DIAL SECTION", "9.5 SLOTIN MECHA SECTION".
Lubricating oil	ZLB-HFD1600	Refer to "9.2 EXTERIOR SECTION", "9.4 JOG DIAL SECTION".
Dyfree	GEM1036	Refer to "9.5 SLOTIN MECHA SECTION".

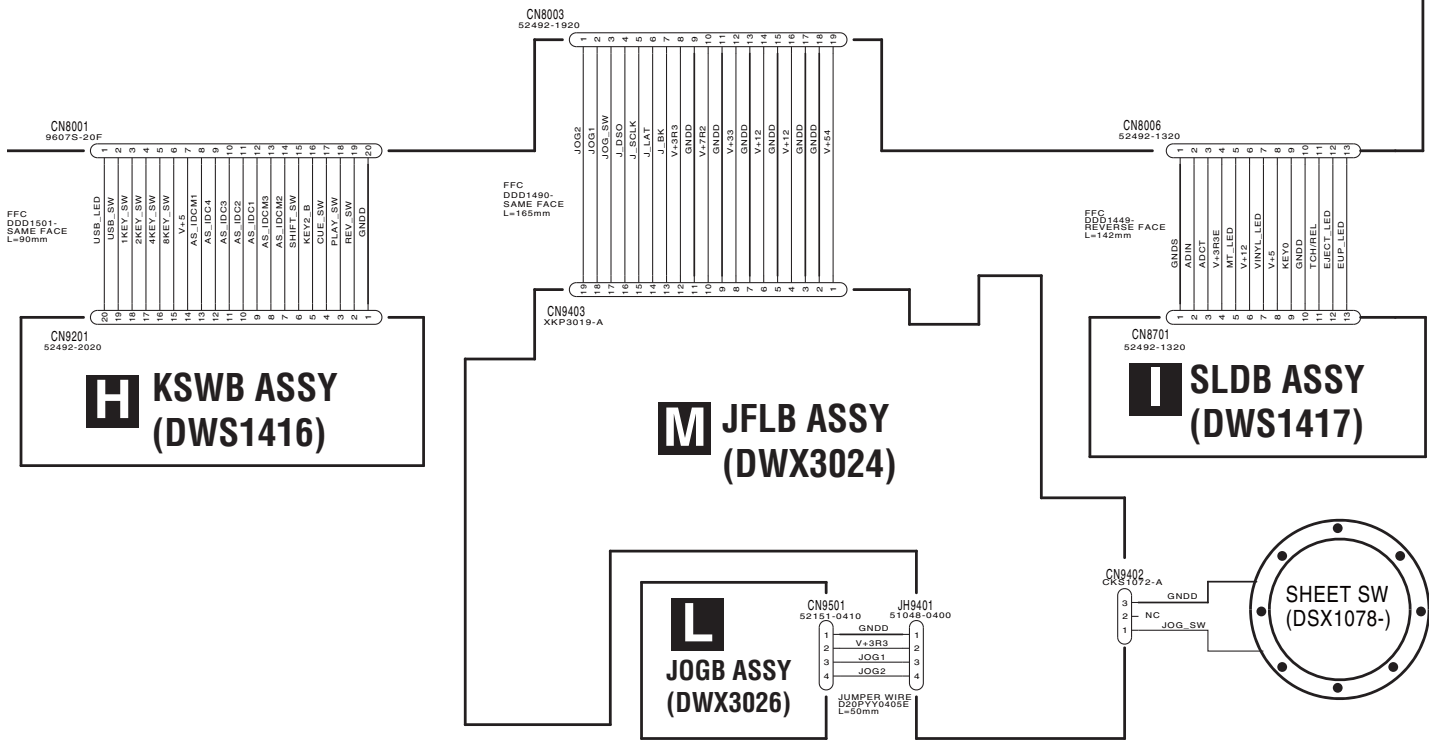

F DFLB ASSY (DWX3021)



- When ordering service parts, be sure to refer to "EXPLODED VIEWS and PARTS LIST" or "PCB PARTS LIST".
- The  mark found on some component parts indicates the importance of the safety factor of the part. Therefore, when replacing, be sure to use parts of identical designation.
-  : The power supply is shown with the marked box.

4.2 SIGNAL BLOCK DIAGRAM

A

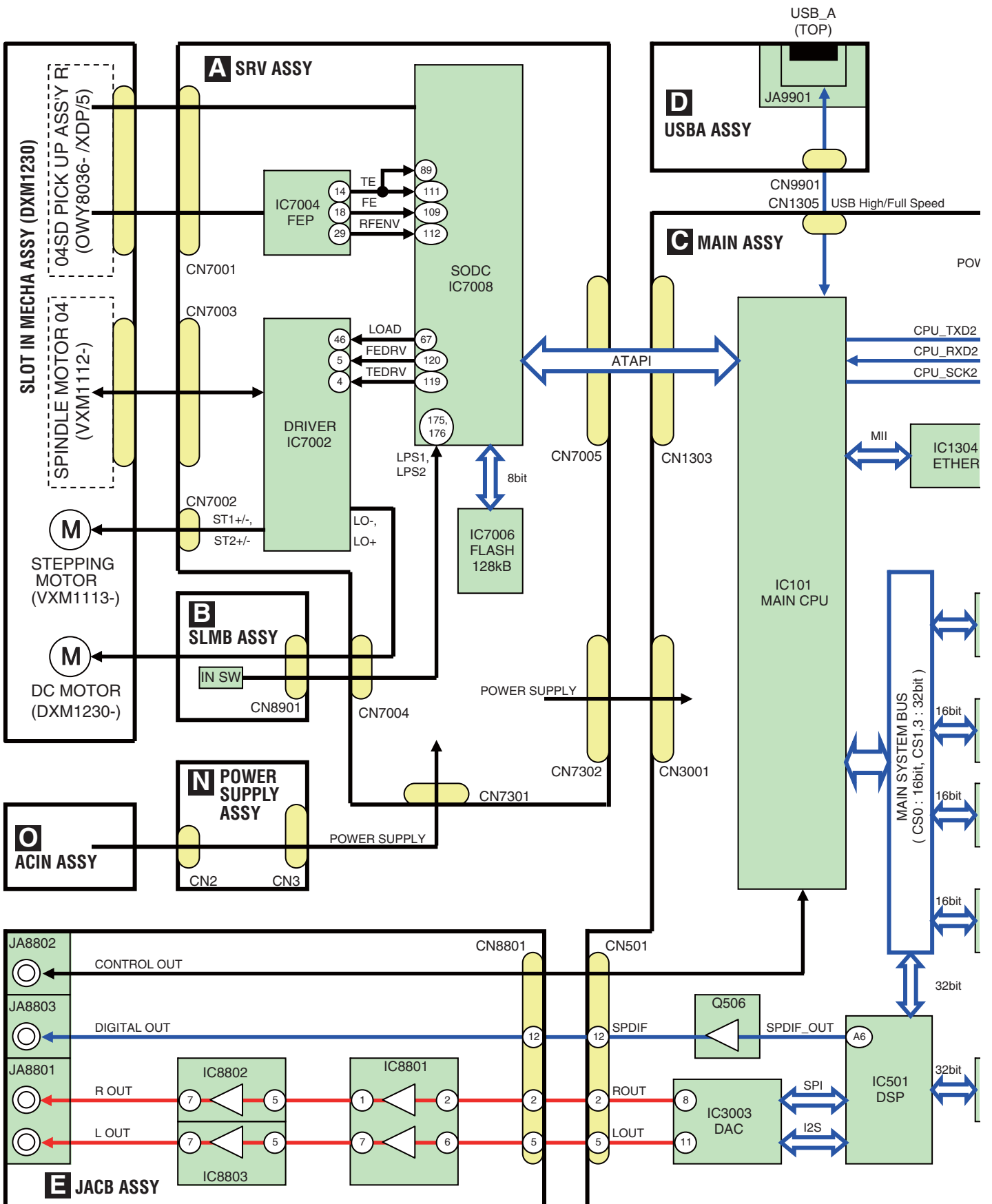

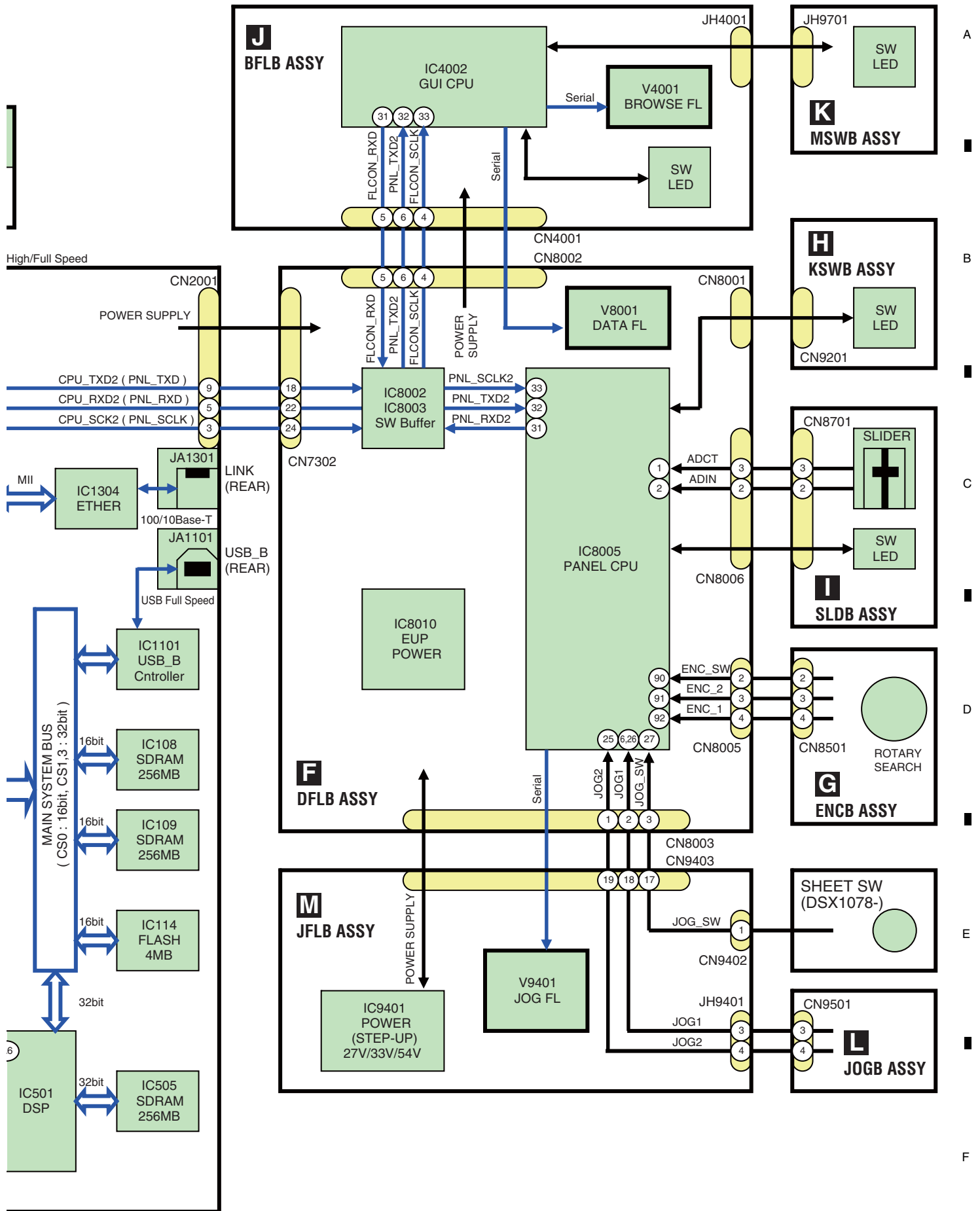

4.3 POWER SUPPLY BLOCK DIAGRAM

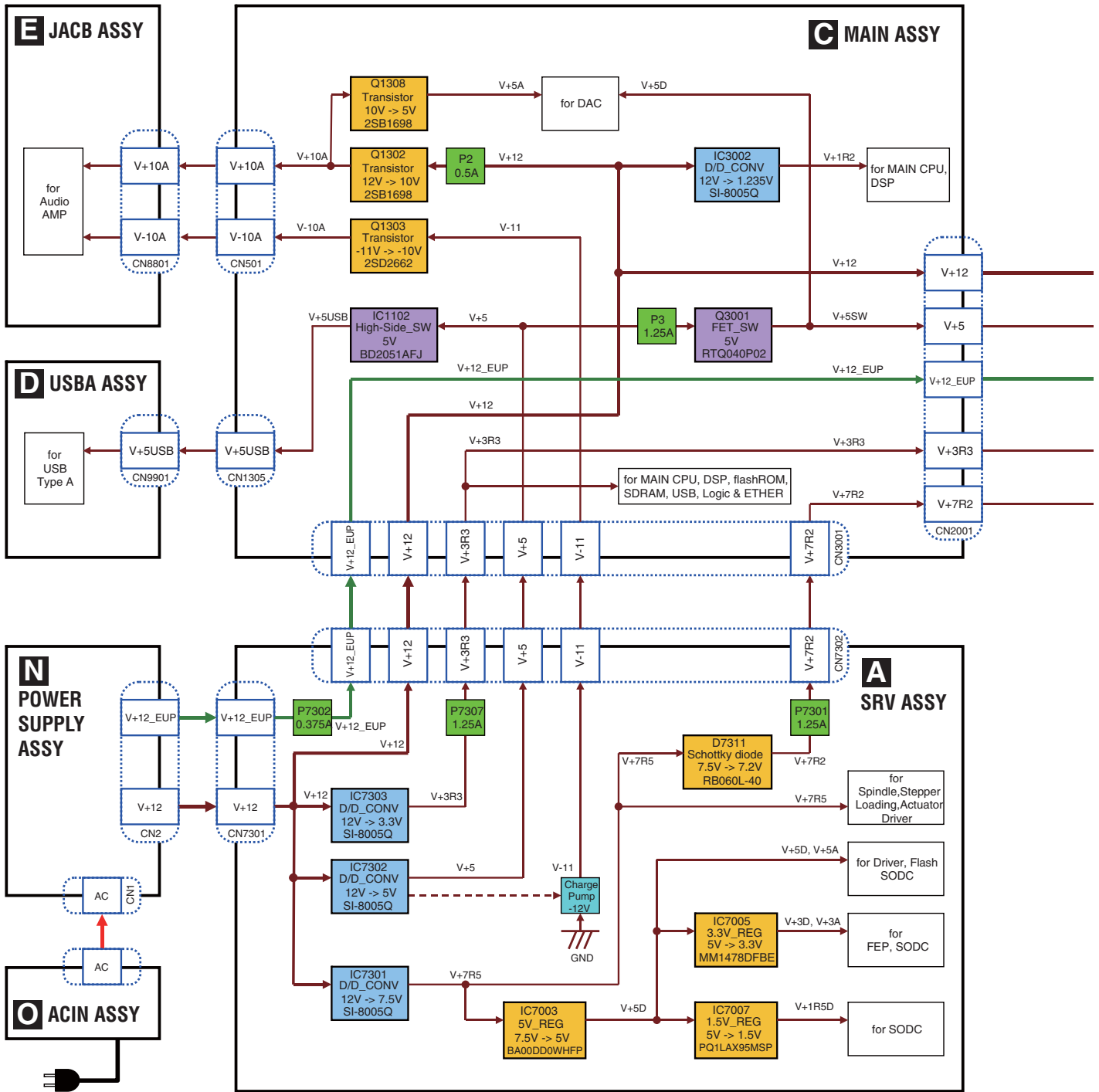

Power supply setup sequence
 Show the power supply controlling the setup order by a circuit.

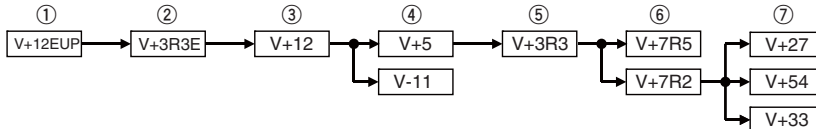

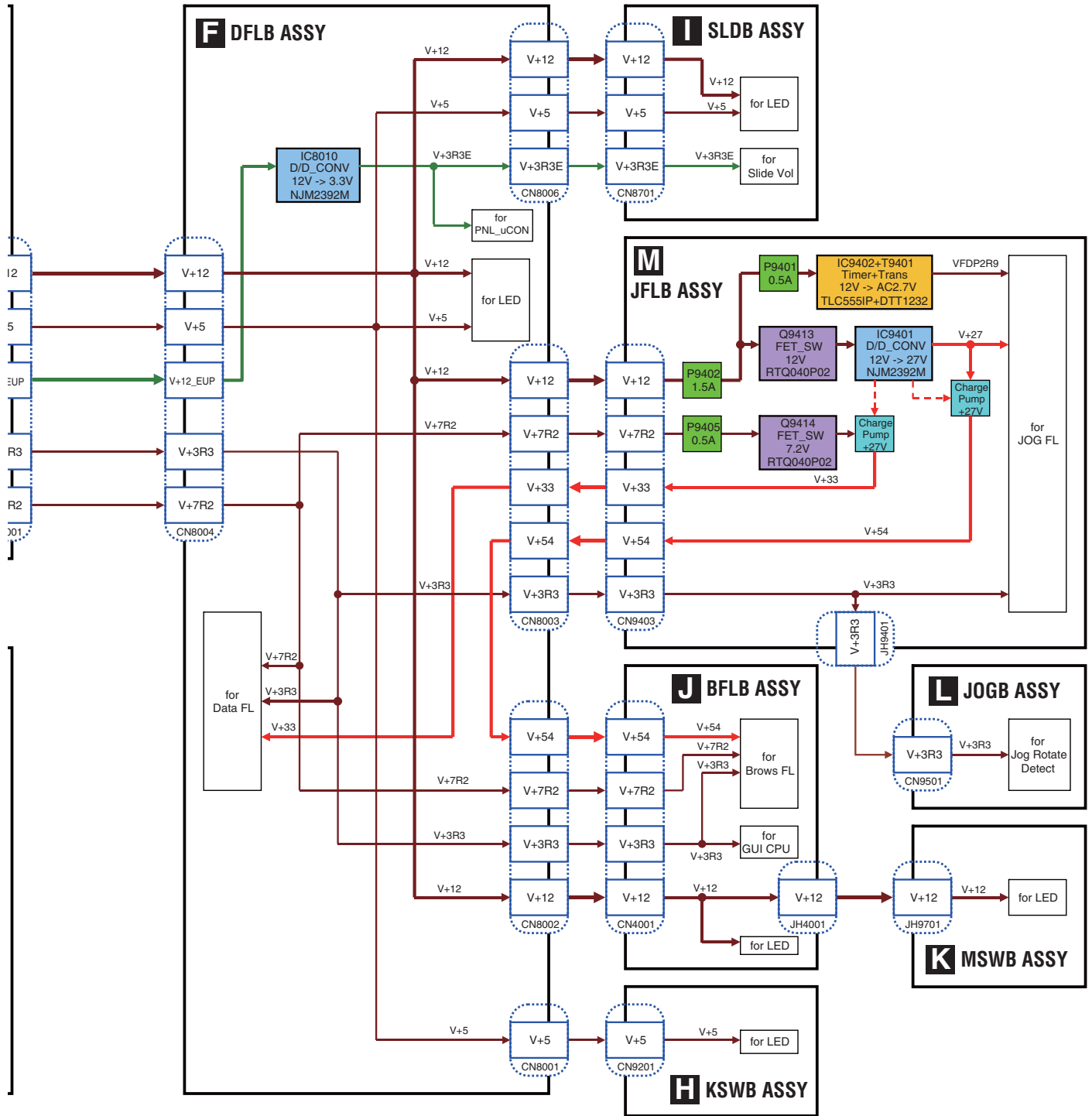

5. DIAGNOSIS

5.1 POWER ON SEQUENCE

Power-on Sequence

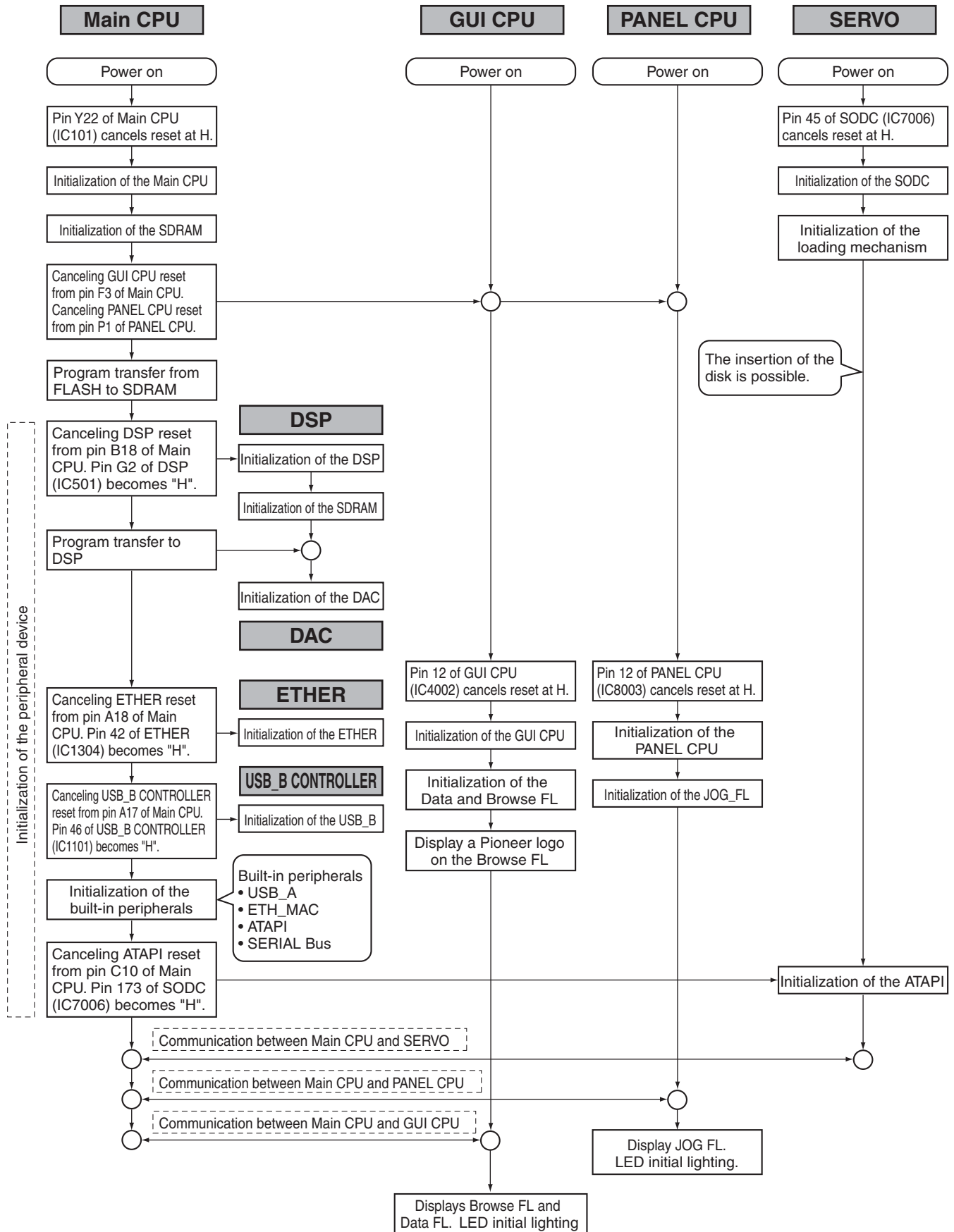

■ Set up Sequence of Servo Section

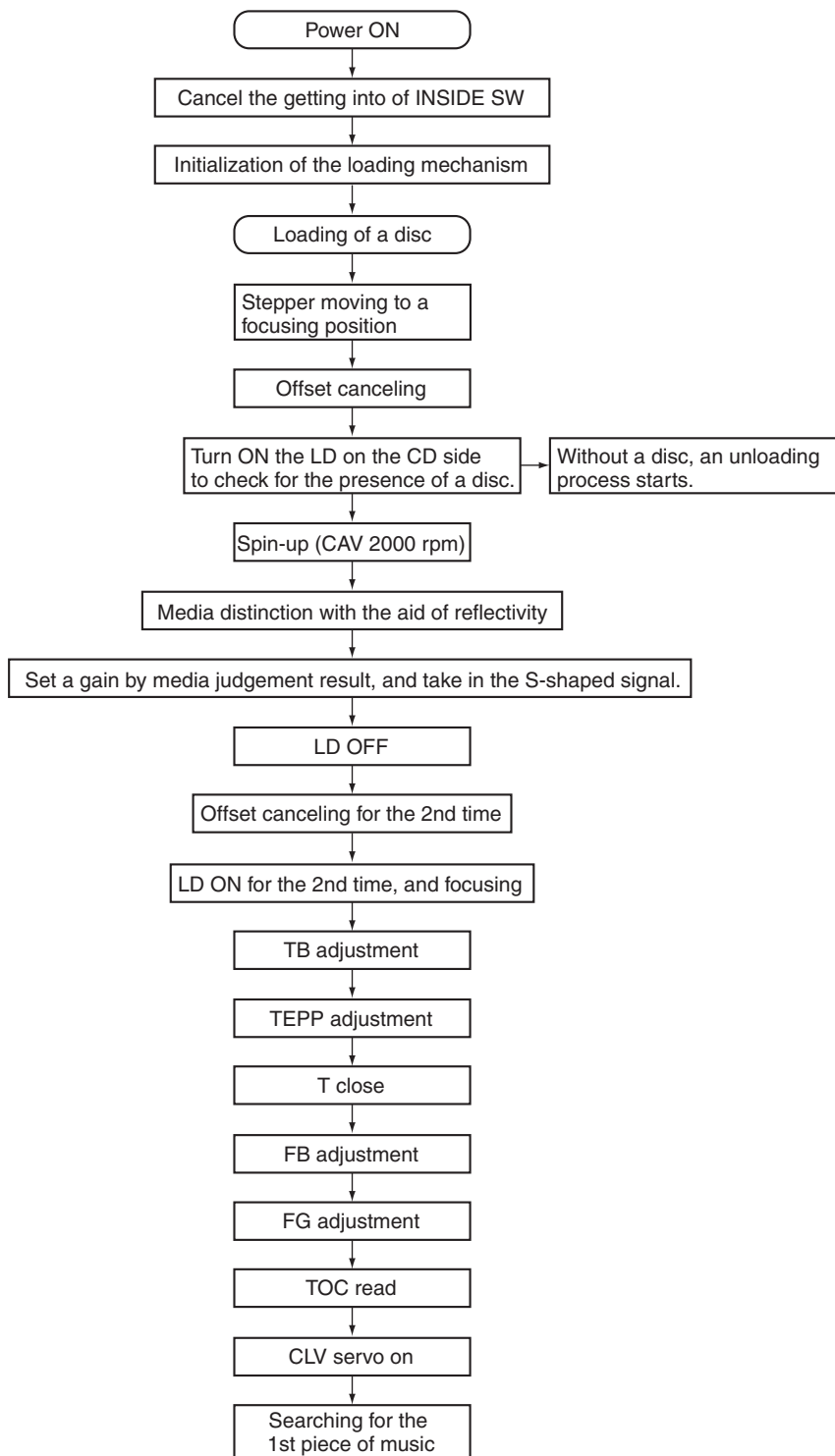

5.2 TROUBLESHOOTING

A

In this section, causes of failure, diagnostics points, and corrective measures can be searched for according to symptoms. Before disassembling this unit, it is recommended to infer a failure point by performing a auto device check/alarm port and referring to the error code.

Note: Alarm port is the Test port on the MAIN Assy.

(Location is referred to the Schematic diagram and PCB Connection diagram.)

For the relationship of each power-supply and signal system, see “4.3 POWER SUPPLY BLOCK DIAGRAM.”

If software of the product is updated before performing diagnostics, check that software updating has been performed properly before proceeding to diagnostics.

If software updating has not been performed properly, update the software, following the instructions in [7] Firmware update of “6.3 DETAILS ON SERVICE MODE.”

B

Contents

- [0] Prior Confirmation
- [1] Failure in Startup
- [2] Display (DATA FL/BROWS FL/JOG FL/LED)
- [3] Operations (SW/Volume/JOG)
- [4] USB (Type A/Type B)
- [5] LAN
- [6] AUDIO OUT
- [7] CONTROL
- [8] DRIVE Assy
- [9] EUP Mode
- [10] SERVICE MODE
- [11] Error Codes

C

The waveform numbers described in this section correspond to the “10.15 WAVEFORMS.”

[0] Prior Confirmation

[0-1] Checking in Service Mode

No.	Cause	Diagnostics Point	Item to be Checked	Corrective Action	Reference
1	—		Check the failure points in auto device check / alarm port.	See the section describing locations of defects in this manual.	6.SERVICE MODE

D

[0-2] Checking Cables

No.	Cause	Diagnostics Point	Item to be Checked	Corrective Action	Reference
1	Disconnection, breakage, or loose connection of cables	Cables	Check that all the cables are securely connected. Check that there is no breakage in the cables.	Securely connect the cables. If a cable is broken, replace it.	4.1 OVERALL CONNECTION DIAGRAM

[1] Failure in Startup

[1-1] No power

E

Even after the unit is turned on, no indication is displayed nor can loading by the DRIVE Assy be performed.

No.	Cause	Diagnostics Point	Item to be Checked	Corrective Action	Reference
1	Defective power supply	SRV Assy	Check V+12.	If V+12 is not checked, go to step 2. If V+12 is checked, go to step 3.	4.3 POWER SUPPLY BLOCK DIAGRAM
2	Defective power supply/Protector breakage	SRV Assy	Check V+12EUP. Check also if the protector (P7302) is broken.	If the protector is broken, replace the protector. If the V+12EUP voltage is not output, the SW power-supply IC may be defective. Replace it.	4.3 POWER SUPPLY BLOCK DIAGRAM
3	Signal errors	SRV Assy	Check the EUP_CONT signal.	If the signal is “L,” check the output from the SW power-supply IC. If V+12 is not output, the SW power-supply IC may be defective. Replace it. If the signal is “H,” check if the signal logics are the same as those for normal status shown in the table in the rightmost column. If either of the signal logics is not the same, check the mounting status of the IC8001 or IC8008 on the DFLB Assy, which corresponds to the wrong signal logic. If it is correctly mounted, then it may be defective. Replace it.	Refer to “Signal logic during EUP mode.”

F

No.	Cause	Diagnostics Point	Item to be Checked	Corrective Action	Reference
4	Defective power supply/Protector breakage	SRV Assy	Check V+7R2, V+5, V+3R3 and check whether protector (P7302) does not break. V+7R2 => P7310 V+3R3 => P7307 Refer to 4.3 POWER SUPPLY BLOCK DIAGRAM.	If the protector is broken, replace the protector. Check the mounting statuses of the regulator IC and its peripheral parts for each power supply. If they are properly mounted, then the parts may be defective. Replace them.	4.3 POWER SUPPLY BLOCK DIAGRAM

Reference: Signal logic during EUP mode

	Normal mode	EUP mode
EUP_CONT	L	H or open
PANEL CPU(IC8005) pin28	H	L
CPU_EUP_CONT	X	L

X : Not Concerned

[1-2] Startup stops with the "Pioneer" logo displayed on the screen. (See *1.)

If startup stops in such a status, the upstream and downstream communications between the MAIN CPU and PANEL CPU/GUI CPU could not be established.

No.	Cause	Diagnostics Point	Item to be Checked	Corrective Action	Reference
1	Version upgrade failed.	—	Version upgrade of the software for the DRIVE unit may have failed.	If upgrading failed, startup stops with the "Pioneer" logo displayed on the screen, and the LED for the USB STOP key flashes repeatedly. See "6. SERVICE MODE."	6.SERVICE MODE
2	—	MAIN Assy	Check a failure point at the status check (alarm) port of the MAIN Assy.	If there is a point that has been judged as in failure, see "6. SERVICE MODE" in this section.	6.SERVICE MODE

[2] Display (DATA FL/BROWS FL/JOG FL/LED)

The DATA FL, BROWS FL and the LEDs (LINK, USB, DISC, BROWS, TAG LIST, INFO, MENU) are controlled by the GUI CPU (IC4002).

The JOG FL and the other LEDs are controlled by the PANEL CPU (IC8005).

[2-1] Any of the DATA, BROWS, and JOG FLs are not lit.

All types of driver power to be supplied are produced at the JFLB Assy.

No.	Cause	Diagnostics Point	Item to be Checked	Corrective Action	Reference
1	Breakage of protectors	JFLB Assy/ SRV Assy	Check V+12 and check whether protectors do not break. JFLB Assy => P9402/P9405 SRV Assy => P7310	If the protector is broken, replace the protector.	4.3 POWER SUPPLY BLOCK DIAGRAM

[2-2] Neither the DATA nor BROWS FL is lit.

Driver power to be supplied to the DATA and BROWS FLs is produced at the JFLB Assy.

No.	Cause	Diagnostics Point	Item to be Checked	Corrective Action	Reference
1	Defective power supply	JFLB Assy	Check supply voltages (V+33/V+54) of the FL.	If the presence of power is confirmed, check the connections to these FLs. If the presence of power is not confirmed, check the mounting statuses of the power circuit (IC9401) and its peripheral parts. If there is any problem, correct it.	4.3 POWER SUPPLY BLOCK DIAGRAM

[2-3] The BROWS FL does not light.

No.	Cause	Diagnostics Point	Item to be Checked	Corrective Action	Reference
1	Defective power supply	BFLB Assy	Check the power-supply voltages (V+3R3/V+7R2/V+54) of the FL.	If the presence of power is not confirmed, check the mounting statuses of the regulator IC and its peripheral parts for each power supply. If they are properly mounted, then the parts may be defective. Replace them.	4.3 POWER SUPPLY BLOCK DIAGRAM
2	Signal errors	BFLB Assy	Check the output signal and connection of communication line of BROWS FL in the BFLB Assy. • B_SCLK • B_BK • B_LAT • B_DSO	If no signal is output, the GUI CPU (IC4002) port may be damaged. Replace it. If soldering is improper, resolder it.	10.10 BFLB ASSY
3	Defective parts of FL		If the symptom persists after the above corrections,	Replace the BROWS FL.	—

A

[2-4] The DATA FL does not light.

No.	Cause	Diagnostics Point	Item to be Checked	Corrective Action	Reference
1	Defective power supply	DFLB Assy	Check the power-supply voltages (V+3R3/V+7R2/V+33) of the FL.	If the presence of power is not confirmed, check the mounting statuses of the regulator IC and its peripheral parts for each power supply. If they are properly mounted, then the parts may be defective. Replace them.	4.3 POWER SUPPLY BLOCK DIAGRAM
2	Signal errors	DFLB Assy	Check the waveforms and connection of the FL communication line in the DFLB Assy. • D_SCLK • D_BK • D_LAT • D_DSO	If no signal is output, the GUI CPU (IC4002) port may be damaged. Replace it. If soldering is improper, resolder it.	10.7 DFLB and ENCB ASSYS 10.10 BFLB ASSY
3	Defective parts of FL		If the symptom persists after the above corrections,	Replace the DATA FL.	—

B

[2-5] The JOG FL does not light.

No.	Cause	Diagnostics Point	Item to be Checked	Corrective Action	Reference
1	Breakage of protectors	JFLB Assy	Check if the protector (P9401) is broken.	If the protector is broken, replace the protector.	—
2	Defective power supply	JFLB Assy	Check the power-supply voltages (V+3R3/VFDP2R9_F1/VFDP2R9_F2/V+27) of the FL.	If the presence of power is not confirmed, check the mounting statuses of the regulator IC and its peripheral parts for each power supply. If they are properly mounted, then the parts may be defective. Replace them.	4.3 POWER SUPPLY BLOCK DIAGRAM
3	Signal errors	JFLB Assy	Check the connection of the FL communication line in the JFLB Assy. • J_SCLK • J_BK • J_LAT • J_DSO	If no signal is output, the GUI CPU (IC4002) port may be damaged. Replace it. If soldering is improper, resolder it.	10.13 JFLB ASSY 10.10 BFLB ASSY
4	Defective parts of FL		If the symptom persists after the above corrections,	Replace the JOG FL.	—

C

[2-6] The LED does not light.

LED (LINK, USB, DISC, BROWS, TAG LIST, INFO and MENU)

No.	Cause	Diagnostics Point	Item to be Checked	Corrective Action	Reference
1	Signal errors	BFLB Assy	Check that the control signal for the LED in question is output from the GUI CPU (IC4002).	If no signal is output, the GUI CPU (IC4002) port may be damaged. Replace it. If soldering is improper, resolder it.	-
2	Defective parts of LED	BFLB Assy	Check that the forward voltage (2.2 - 2.7 V) is present at both ends of the LED.	If the forward voltage is not present, then the LED itself is defective. Replace it.	-
3	Defective parts of transistor	BFLB Assy	If the symptom persists after the above corrections,	The transistor is defective. Replace it.	-

D

LED (except for the USB STOP indicator) on KSWB Assy does not light.

No.	Cause	Diagnostics Point	Item to be Checked	Corrective Action	Reference
1	Breakage of protectors	MAIN Assy	Check if the protector (P3) is broken.	If the protector is broken, replace the protector.	-
2	-	-	The LEDs (except for the USB STOP indicator) on the KSWB Assy are lit dynamically in a matrix pattern. Check if the unlit LED belongs to a certain line/column group, referring to the circuit diagrams.	If it does not belong to a group, then that LED may be defective. Replace it. If it belongs to a group, then the LED-drive signal for that group is defective. Go to [2].	10.8 KSWB ASSY (Schematic diagram)
3	Signal errors	DFLB Assy	Check that the control signal for the LED in question is output from the PANEL CPU (IC8005).	If no signal is output, the PANEL CPU (IC8005) port may be damaged. Replace it. If soldering is improper, resolder it.	-
4	-	-	If the symptom persists after the above corrections,	The transistor is defective. Replace it.	-

E

USB STOP indicator does not light.

This LED is controlled by the MAIN CPU (IC101).

No.	Cause	Diagnostics Point	Item to be Checked	Corrective Action	Reference
1	Breakage of protectors	MAIN Assy	Check if the protector (P3) is broken.	If the protector is broken, replace the protector.	-
2	Defective parts of LED	BFLB Assy	Check that the forward voltage (2.2 - 2.7 V) is present at both ends of the LED.	If the forward voltage is not present, then the LED itself is defective. Replace it.	-
3	Defective connection/ Signal errors	MAIN Assy/ DFLB Assy/ KSWB Assy	Check the connection of the LED control signal.	If the signal is not output even if the connections are properly made, the port on the MAIN CPU (IC101) may be damaged. Replace it.	-
4	-	-	If the symptom persists after the above corrections,	The transistor is defective. Replace it.	-

F

Other LED does not light.					
No.	Cause	Diagnostics Point	Item to be Checked	Corrective Action	Reference
1	Breakage of protectors	Related point	Check the drive voltage of the unlit LED. For the 5-V-driven LEDs, check if the protector (P3) is broken.	If the protector is broken, replace the protector.	-
2	Signal errors	-	Check that the signal for the LED in question is output from the PANEL CPU (IC8005).	When there is not output signal, check the connection of the PANEL CPU (IC8005). If the connection is OK, the port may be damaged. Replace it.	-
3	Defective parts of LED	-	Check that the forward voltage (2.2 - 2.7 V) is present at both ends of the LED.	If the forward voltage is not present, then the LED itself is defective. Replace it.	-
4	Defective parts of transistor	-	If the symptom persists after the above corrections,	The transistor is defective. Replace it.	-

[3] Operations (Keys/variable controls/JOG)

As operations of all keys, variable controls, and JOG dial can be checked in Service mode.

[3-1] No key functions

The PLAY, CUE, AUTO BEAT LOOP, BEAT SELECT, REV, LOOP IN, LOOP OUT, or RELOOP key does not function.					
No.	Cause	Diagnostics Point	Item to be Checked	Corrective Action	Reference
1	Loose connection /Defective SW	Related point	Check if there is loose connection on the signal line from the PANEL CPU (IC8005) up to the SW.	If there is no loose connection and if the signal does not become L when the SW is pressed, that SW is defective. Replace it.	-
2	Defective PANEL CPU (IC8005)	DFLB Assy	If the symptom persists after the above corrections,	Check the connection of the PANEL CPU (IC8005). If the connection is OK, the port may be damaged. Replace it.	-
Other keys (except for the USB STOP key) do not function. The signals from other keys are analog and connected to multiple switches.					
No.	Cause	Diagnostics Point	Item to be Checked	Corrective Action	Reference
1	Loose connection /Defective SW	Related point	Check if there is loose connection on the signal line from the PANEL CPU (IC8005) up to the SW.	If the SWs connected to the signal line function properly and if the connections are properly made, the SWs may be defective. Replace them.	-
2	Defective PANEL CPU (IC8005)	DFLB Assy	If the symptom persists after the above corrections,	Check the connection of the PANEL CPU (IC8005). If the connection is OK, the port may be damaged. Replace it.	-
The USB STOP key does not function. The USB STOP key is controlled by the MAIN CPU.					
No.	Cause	Diagnostics Point	Item to be Checked	Corrective Action	Reference
1	Loose connection /Defective SW	KSWB Assy/ MAIN Assy	Check if there is loose connection on the signal line from the MAIN CPU (IC101) up to the SW.	If there is no loose connection and if the signal does not become L when the SW is pressed, that SW is defective. Replace it.	-
2	Defective MAIN CPU (IC101)	MAIN Assy	If the symptom persists after the above corrections,	The MAIN CPU (IC101) is defective. Replace it.	-

[3-2] Rotary selector not controllable

No.	Cause	Diagnostics Point	Item to be Checked	Corrective Action	Reference
1	Defective rotary selector	ENCB Assy	Check if the signals from the ENC_1, ENC_2, and ENC_SW signal lines are normal when the rotary selector is turned or pressed.	If the signals are not normal, check the connections of the signal lines. If the connections are properly made, the encoder selector may be defective. Replace it.	10.7 DFLB and ENCB ASSYS
2	Defective PANEL CPU (IC8005)	DFLB Assy	If the symptom persists after the above corrections,	Check a mounting state of PANEL CPU(IC8005). If the mounting is OK, the PANEL CPU is damaged. Replace it.	-

[3-3] Variable controls not controllable

Tempo slider not controllable					
No.	Cause	Diagnostics Point	Item to be Checked	Corrective Action	Reference
1	Loose connection	SLDB Assy /DFLB Assy	Check if there is loose connection on the signal line from the PANEL CPU (IC8005) to the tempo slider (VR8701).	If the connections of signal line are improper, resolder it.	-
2	Defective tempo slider	SLDB Assy	Check the waveforms of signal lines (ADCT/ADIN) .	If the voltage of the signal line (ADIN) does not change between 3.3 V and 0 V, the tempo slider (VR8701) may be defective. Replace it.	-
3	Defective PANEL CPU (IC8005)	DFLB Assy	If the symptom persists after the above corrections,	Check a mounting state of PANEL CPU(IC8005). If the mounting is OK, the port may be damaged. Replace it.	-

A

VINYL SPEED ADJUST not controllable					
No.	Cause	Diagnostics Point	Item to be Checked	Corrective Action	Reference
1	Loose connection	SLDB Assy /DFLB Assy	Check if there is loose connection on the signal line from the PANEL CPU (IC8005) to the SPEED ADJUST(VR8702).	If the connections of signal line are improper, resolder it.	-
2	Defective VOL	SLDB Assy	Check the waveforms of signal lines (TCH/REL).	If the voltage of the signal line (TCH/REL) does not change between 3.3 V and 0 V, the VINYL SPEED ADJUST (VR8702) may be defective. Replace it.	-
3	Defective PANEL CPU (IC8005)	DFLB Assy	If the symptom persists after the above corrections,	Check a mounting state of PANEL CPU(IC8005). If the mounting is OK, the port may be damaged. Replace it.	-

B

[3-4] Abnormalities regarding the JOG dial

After the JOG Assy is disassembled then reassembled, be sure to check that the load value for the JOG dial is within the specified range.

C

Turning of the JOG dial is not detected					
No.	Cause	Diagnostics Point	Item to be Checked	Corrective Action	Reference
1	Defective photo interrupter	JOGB Assy/ JFLB Assy/ DFLB Assy	Check the waveforms of signal lines (JOG1/JOG2).	If no waveform can be confirmed, the photo interrupter (PC9501) may be defective. Replace it.	-
2	Defective PANEL CPU (IC8005)	DFLB Assy	If the symptom persists after the above corrections,	Check a mounting state of PANEL CPU (IC8005). If the mounting is OK, the port may be damaged. Replace it.	-

D

Pressing on the JOG dial cannot be detected.					
No.	Cause	Diagnostics Point	Item to be Checked	Corrective Action	Reference
1	Defective SHEET SW	JFLB Assy /DFLB Assy	Check the waveform of the signal on the signal line (JOG_SW) when the JOG dial is pressed.	If the signal on the signal line (JOG_SW) is not set to L when the JOG dial is pressed, the SHEET SW (DSX1078-A) may be defective. Replace it.	-
2	Defective PANEL CPU (IC8005)	DFLB Assy	If the symptom persists after the above corrections,	Check a mounting state of PANEL CPU(IC8005). If the mounting is OK, the port may be damaged. Replace it.	-

E

Noise is heard when the JOG dial is turned.					
No.	Cause	Diagnostics Point	Item to be Checked	Corrective Action	Reference
1	Defective JFLB Assy or gears	JOG Assy	Check if the JOG FL of the JFLB Assy has been shifted upward from the holder.	The JOG FL may interfere with JOG A. Replace the JFLB Assy.	-
			There may be any scratches on the 3 gears or some foreign object between the gears.	If there are any scratches, replace the scratched gear with a new one. If there is any foreign object, remove it then replace the gears with new ones. Gears to be replaced: Load gear, Gear A, Gear B	-

F

The JOG dial turns too freely. (The load value for the JOG dial is outside the specified range.)					
No.	Cause	Diagnostics Point	Item to be Checked	Corrective Action	Reference
1	Improper adjustment or assembly of the JOG dial	JOG Assy	Check that the load value for the JOG dial is within the specified range, referring to "Measuring method" in "8.1 JOG Dial Rotation Load Adjustment."	If it is outside the specified range, adjust the position of the Adjust Plate to change the load value for the JOG dial, referring to "How to Adjust" in "8.1 JOG Dial Rotation Load Adjustment."	8.1 JOG Dial Rotation Load Adjustment.
				During the above adjustment, if the upper-limit adjustment position of the Adjust Plate is reached, oil may have been spattered on the Adjust Plate. Replace the washer, gear, and cam plate with new ones, then reassemble.	-
Resistance to turning the JOG dial is too strong. (The load value for the JOG dial is outside the specified range.)					
No.	Cause	Diagnostics Point	Item to be Checked	Corrective Action	Reference
1	Improper adjustment of the JOG dial or defective washer, gear, or cam plate	JOG Assy	Check that the load value for the JOG dial is within the specified range, referring to "Measuring method" in "8.1 JOG Dial Rotation Load Adjustment."	If it is outside the specified range, adjust the position of the Adjust Plate to change the load value for the JOG dial, referring to "How to Adjust" in "8.1 JOG Dial Rotation Load Adjustment."	8.1 JOG Dial Rotation Load Adjustment.
				During the above adjustment, if the lower-limit adjustment position of the Adjust Plate is reached, shavings from the worn-out washer may have increased the friction. Replace the washer, gear, and cam plate with new ones, then reassemble.	-

[4] USB (Type A/Type B)

[4-1] No communication via the USB connector (Type A)

Check the following, with a USB device connected to the USB A connector.

No.	Cause	Diagnostics Point	Item to be Checked	Corrective Action	Reference
1	Loose connections	USBA Assy /MAIN Assy	Check the connection of the USB communication line.	If connection is improper, resolder it. If connection is proper, go to step [2].	-
2	V+5_USB_HOST_VBUS is defective.	MAIN Assy	Check V+5_USB of the USB power supply.	If V+5_USB cannot be confirmed, check V+5. If the V+5 is OK, then go to [3]. If V+5_USB can be confirmed, go to [4].	-
3	The USB PAWED IC is defective. /Signal errors	MAIN Assy	Check the CPU_USB_HSTPWREN and CPU_USB_HSTPWRFL signals from the USB POWER HIGH SIDE SW(IC1102)	If the CPU_USB_HSTPWREN signal does not become H, check the connection. If the connection is OK, then the MAIN CPU (IC101) is defective. Replace it. If the CPU_USB_HSTPWRFL signal does not become H, the USB POWER HIGH SIDE SW (IC1102) is in a state of shutdown caused by abnormally high temperature. Check the connection. If the connection is OK, then the port may be damaged. Replace it.	10.5 MAIN ASSY(3/3), USBA ASSY
4	Defective MAIN CPU	MAIN Assy	If the symptom persists after the above corrections,	The MAIN CPU (IC101) is defective. Replace it.	-

[4-2] No communication via the USB connector (Type B)

Check the following, with a USB device connected to the USB B connector.

No.	Cause	Diagnostics Point	Item to be Checked	Corrective Action	Reference
1	Loose connections		Check the connection of the signal lines (USB_D+/USB_D-).	If connection is improper, resolder it.	-
2	Defective USB CONTROLLER		If the symptom persists after the above corrections,	The USB CONTROLLER (IC1101) may be defective. Replace it.	-

[5] LAN

[5-1] No LAN communication

Check the following, with a peripheral device connected to the Ethernet connector.

No.	Cause	Diagnostics Point	Item to be Checked	Corrective Action	Reference
1	Loose connections	MAIN Assy	Check the connection of the periphery circuit of ETHER PHY CHIP (IC1304).	Check the connections of the communication line. If connection is improper, resolder it.	-
2	Defective ETHER PHY CHIP or MAIN CPU	MAIN Assy	If the symptom persists after the above corrections,	The ETHER PHY CHIP (IC1304) may be defective. Replace it. If the symptom persists, the MAIN CPU (IC101) may be defective. Replace it.	-

[6] AUDIO OUT

[6-1] No sound

The analog audio signal is not output.

No.	Cause	Diagnostics Point	Item to be Checked	Corrective Action	Reference
1	Defective power supply	MAIN Assy /JACB Assy	Check the voltages for audio (V+10A/V-10A/REF2R5). Check also if the protector (P2) is broken.	If the protector is broken, replace the protector. • If V+10A is not output, check the mounting statuses of Q1302 and Q1304. If there is any problem, correct it. • If V-10A is not output, check the mounting statuses of Q1303 and Q1305. If there is any problem, correct it. • If VREF2R5 is not output, go to [3].	-
2	Loose connections	MAIN Assy /JACB Assy	Check the connection of the audio signal lines (ROUT/LOUT).	If connection is improper, resolder it.	-
3	Signal errors	MAIN Assy	Check the voltages for DAC (IC3003) (V+5A/V+5D). Check also if the protector (P3) is broken.	If the protector is broken, replace the protector. If V+5A is not supplied, see "4.3 POWER SUPPLY BLOCK DIAGRAM", then check the mounting statuses of peripheral parts. If there is any problem, correct it. If the mounting is OK, the parts be defective. Replace it.	-
4			Check the input signal of the DAC(IC3003). • DSP_SPICLK • DSP_DATA • DSP_SPISIMO • DSP_SPICS • DSP_MCLK • DSP_LRCK2 • DSP_BCLK2	If input of any of the signals cannot be confirmed, check the connections. If soldering is improper, resolder it. If soldering is properly made, then the DSP (IC501) may be defective. Replace it.	10.4 MAIN ASSY(2/3)

The digital audio signal is not output.

No.	Cause	Diagnostics Point	Item to be Checked	Corrective Action	Reference
1	Loose connections	JACB Assy	Check the digital audio signal (SPDIF) and its connection.	If connection is improper, resolder it. If the SPDIF signal cannot be recognized, go to Step [3].	-
2	Signal errors	MAIN Assy	Check the digital audio signal (SPDIF_OUT).	If the SPDIF_OUT signal can be recognized, then the transistor (Q506) may be defective. Check the connection. If no problem is found, replace the transistor. If the SPDIF_OUT signal cannot be recognized, check the connection. If soldering is improper, resolder it.	10.4 MAIN ASSY(2/3)
3		MAIN Assy	If the symptom persists after the above corrections,	Replace the DSP (IC501).	-

[7] CONTROL

[7-1] Improper fader operation after fader start

No.	Cause	Diagnostics Point	Item to be Checked	Corrective Action	Reference
1	Signal errors	JACB Assy	Check the waveforms of the control signals (CONT1/CONT2) from the CN8801 on the JACB Assy.	If the signal cannot be recognized, the JACB Assy may be defective. Check the soldering at the JACB Assy then resolder it, if necessary. If the signal can be recognized, go to Step [2].	10.15 WAVEFORMS ④⑦, ④⑧
2	Signal errors	MAIN Assy	Check the waveforms of the control signals (CONT00/CONT01/CONT02) from the MAIN Assy.	If the input signal can be recognized, then the MAIN CPU (IC101) may be defective. Replace it. If the input signal cannot be recognized, the communication line or the peripheral devices may be loosely connected. Resolder the terminals.	-

[8] DRIVE ASSY

[8-1] Improper operation of the loading mechanism

No.	Cause	Diagnostics Point	Item to be Checked	Corrective Action	Reference
1	Improper soldering	Cables	Check that the wires between the loading motor and the SLMB Assy are securely soldered. Check also the wires are not broken.	If soldering is improper, resolder it. If the wires are broken, replace them.	-
2	Defective power supply	SRV Assy	Check the power voltages. (V+7R5, V+5D, V+3D, V+3A, V+1R5 and VHALF)	For any power-supply section that does not output the voltage, check the mounting statuses of the regulator IC and its peripheral parts. If they are properly mounted, then the parts may be defective. Replace them.	4.3 POWER SUPPLY BLOCK DIAGRAM
3	Signal errors	SRV Assy	Check the waveforms of the LPS1 and LPS2 signal lines. (The LPS1 and LPS2 signals becomes L when the SW is set to ON.)	If the signal waveform is not proper, the loading detection SWs (S8901/S8902) may be improperly soldered or defective. If soldering is improper, resolder them. If the symptom persists, replace the defective parts.	10.1 SRV ASSY (1/2) 10.15 WAVEFORMS ②, ③

No.	Cause	Diagnostics Point	Item to be Checked	Corrective Action	Reference
4	Signal errors	SRV Assy	Check the waveforms of the MUTE1 and MUTE2 signals. (During loading, the MUTE1 signal is L and the MUTE2 signal is H.)	If the signal waveform is not proper, check the mounting statuses of the DRIVER IC (IC7002) and SODC (IC7008) terminals. If they are properly mounted, then the SODC (IC7008) may be defective. Replace it.	10.1 SRV ASSY(1/2)
5	Signal errors	SRV Assy	Check the LOAD signal.	DRIVER IC (IC7002) and SODC (IC7008) may be improperly soldered or defective. Resolder them, if necessary. If the symptom persists, replace SODC (IC7008).	10.1 SRV ASSY (1/2) 10.15 WAVE-FORMS ④
6		CD drive	If the symptom persists after the above corrections,	Replace the SRV Assy.	-
No loading (There is an abnormal noise.)					
No.	Cause	Diagnostics Point	Item to be Checked	Corrective Action	Reference
1	Improper assembling	CD drive	Check if the loading arm has shifted on the SWs on the SMLB Assy.	If the loading arm has shifted on the loading detection SWs (S8901/S8902), correct the position of the loading arm. If the soldered SWs are lifted off the board, resolder them.	-
2	Signal errors	SRV Assy	Open the bottom plate of the DRIVE UNIT then check the waveforms on the LPS1 and LPS2 signal lines.	The loading detection SWs (S8901 and S8902) may be improperly soldered or defective. Resolder them, if necessary. If the symptom persists, replace them.	10.1 SRV ASSY (1/2) 10.15 WAVE-FORMS ②, ③

[8-2] The stepper does not work.

No.	Cause	Diagnostics Point	Item to be Checked	Corrective Action	Reference
1	Defective power supply	SRV Assy	Check the power voltages (V+7R5, V+5D, V+3D, V+3A, V+1R5 and VHALF).	Check the connection of the parts at the periphery of the regulator IC that does not output the voltage. If the symptom persists after a corrective action, the power supply block is defective. Replace it.	4.3 POWER SUPPLY BLOCK DIAGRAM
2	Signal errors	SRV Assy	Check the INSIDE signal. (The INSIDE SW becomes L when the INSIDE SW is set to ON.)	If the signal is not proper, check the connections. If connections are properly made, replace the traverse mechanism.	10.1 SRV ASSY(1/2)
3	Signal errors	SRV Assy	Check that the MUTE1 signal becomes H after loading is completed.	DRIVER IC (IC7002) and SODC (IC7008) may be improperly soldered or defective. Resolder them, if necessary. If the symptom persists, replace SODC (IC7008).	10.1 SRV ASSY(1/2)
4	Signal errors	SRV Assy	Check that a sine-wave signal is input to Pins 29 and 30 of DRIVER IC (IC7002).	DRIVER IC (IC7002) and SODC (IC7008) may be improperly soldered or defective. Resolder them, if necessary. If the symptom persists, replace SODC (IC7008).	10.1 SRV ASSY (1/2) 10.15 WAVE-FORMS ⑨, ⑩
5	Defective parts	CD drive Assy	If the symptom persists after the above corrections,	Replace the parts in the order of (1) DRIVER IC (IC7002), (2) SRV Assy, then (3) traverse mechanism.	-

[8-3] No CD playback

No.	Cause	Diagnostics Point	Item to be Checked	Corrective Action	Reference
1	Any foreign matter attached	CD drive Assy	Check if the objective lens is dirty.	Remove any dirt or dust from the lens.	-
2	Defective pickup	SRV Assy	Check the LD current value. Measure the actuator resistance value.	Refer to the "5.3 Failure Judgment of the Pickup Assy."	5.3 Failure Judgment of the Pickup Assy
3	-	Service mode	If the symptom persists after the above corrections, check operations of the CD drive in Service mode.	Check operations of the CD drive, referring to the procedures described in "6. SERVICE MODE." If the CD drive functions improperly, see "[10] SERVICE MODE" in this section.	6. Service mode

[9] EUP Mode

[9-1] Mode shift error in Standby mode

Shifting to EUP mode is not possible.

No.	Cause	Diagnostics Point	Item to be Checked	Corrective Action	Reference
1	Defective PANEL CPU	DFLB Assy	Check that the signal from Pin 28 of the PANEL CPU (IC8005) changes from H to L during mode shift.	The PANEL CPU (IC8005) may be defective. Check the soldering of the PANEL CPU and its periphery. If the soldering is OK, then replace it.	Refer to "Signal logic during EUP mode."
2	Disconnection, breakage, or loose connection of cables	SRV Assy	Check that the signal from EUP_CONT (Pin 3 of the CN7301) changes from L to H during mode shift.	The signal line cable may be defective. If it is loosely connected, securely connect it. If it is broken, replace it.	
3	Defective SW power supply	SW power supply	If the symptom persists after the above corrections,	The SW power-supply is defective. Replace it.	-

EUP mode cannot be exited.

No.	Cause	Diagnostics Point	Item to be Checked	Corrective Action	Reference
1	Defective PANEL CPU	DFLB Assy	Check that the signal from Pin 28 of the PANEL CPU (IC8005) changes from L to H during mode shift.	The PANEL CPU (IC8005) may be defective. Check the soldering of the PANEL CPU and its periphery. If the soldering is OK, then replace it.	Refer to "Signal logic during EUP mode."
2	Disconnection, breakage, or loose connection of cables	SRV Assy	Check that the signal from EUP_CONT (Pin 3 of the CN7301) changes from H to L during mode shift.	The signal line cable may be defective. If it is loosely connected, securely connect it. If it is broken, replace it.	
3	Defective SW power supply	SW power supply	If the symptom persists after the above corrections,	The SW power-supply is defective. Replace it.	-

Reference: Signal logic during EUP mode

	Normal mode	EUP mode
EUP_CONT	L	H or open
PANEL CPU(IC8005) pin28	H	L
CPU_EUP_CONT	X	L

X : Not Concerned

[10] SERVICE MODE

[10-1] The measured error rate is outside the specified range in Player Operation mode.

No.	Cause	Diagnostics Point	Item to be Checked	Corrective Action	Reference
1	Scratches or dirt on the disc	DISC	First, whether the cause is attributable to the disc or to the player must be distinguished. Check if the recording surface of the disc is dirty.	If it is clearly dirty, replace it with a CD of good condition.	-
2	Scratches or dirt on the disc	DISC	Measure the error rate, using the same disc that produced the bad error rate but using the addresses in a different area. If the error rate measured in a different area is OK, the CD is defective.	If the error rate measured in a different area is OK, the CD is defective. Replace the CD with one in good condition. If no error rate measured in various areas throughout the entire surface of the CD is OK, go to [3].	-
3	Any foreign matter attached	Traverse mechanism	Check if any foreign matter, such as shavings, dirt, or dust, is attached to the lens of the Pickup Assy.	Clean the lens.	-
4	Improper assembly	Traverse mechanism	Check that the traverse mechanism has been securely installed.	If it has not, reinstall it properly.	-
5	Improper assembly	Traverse mechanism	Check that the loading mechanism Assy has been securely installed.	If it has not, reinstall it properly.	-
6	Any foreign matter attached	Traverse mechanism	Check for any foreign matter on the spindle table.	Remove any foreign matter.	-
7	Any foreign matter attached	Traverse mechanism	Check if any foreign matter is attached to the magnet portion of the Pickup Assy.	Remove any foreign matter.	-
8	Signal errors	SRV Assy	Check that the waveforms of the RF, ARF_P, and ARF_N signals form clear eye patterns.	If their waveforms are not of the same quality, check the mounting status of the FEP (IC7004). If it is correctly mounted, then it may be defective. Replace it.	10.15 WAVEFORMS ①
9	Signal errors	SRV Assy	Check that the signal from RW/XR (Pin 7 of CN7001) is H during playback.	Check the mounting status of the SODC (IC7008). If it is properly mounted, then the port may be damaged. Replace it.	10.1 SRV ASSY(1/2)
10	Defective pickup	Traverse mechanism	If the symptom persists after the above corrections,	See "5.3 Failure Judgment of the Pickup Assy" for details.	5.3 Failure Judgment of the Pickup ASSY

[10-2] The drive does not work during Test Operation mode.

The LD does not emit light.

No.	Cause	Diagnostics Point	Item to be Checked	Corrective Action	Reference
1	Defective pickup	-	Check the LD current and measure the resistance value of the actuator.	See "5.3 Failure Judgment of the Pickup Assy" for details.	5.3 Failure Judgment of the Pickup ASSY

The spindle motor does not rotate.

No.	Cause	Diagnostics Point	Item to be Checked	Corrective Action	Reference
1	Signal errors	SRV Assy	Check that the MUTE1 signal becomes H after loading is completed.	If the signal is not output, check the mounting statuses of the DRIVER IC (IC7002) and SODC (IC7008) terminals. If they are properly mounted, then the SODC (IC7008) may be defective. Replace it.	10.1 SRV ASSY(1/2)
2	Signal errors	SRV Assy	Check that the SPDLEC signal is a PWM signal with 1.65 V at the center.	If the signal is not output, check the mounting statuses of the DRIVER IC (IC7002) and SODC (IC7008) terminals. If they are properly mounted, then the SODC (IC7008) may be defective. Replace it.	10.1 SRV ASSY(1/2)
3	Signal errors	SRV Assy	Check that the SLIN1 signal to Pin 29 of IC7002 is 3.3 V when disc rotation is at full speed.	If the signal is not input, check the connections. If soldering is improper, resolder it.	10.1 SRV ASSY(1/2) 10.15 WAVEFORMS ⑨

No.	Cause	Diagnostics Point	Item to be Checked	Corrective Action	Reference
4	Defective power supply	SRV Assy	Check the power voltages (V+5A, VREF1, VREF2 and VHALF).	If V+5A is not output, check the mounting statuses of the regulator IC of the power-supply section that produces that voltage and its peripheral parts. If they are properly mounted, then the parts may be defective. Replace them. Other voltages (VREF1, VREF2, and VHALF) are produced at the FEP (IC7004). If these voltages are not output, check the mounting status of the FEP. If it is properly mounted, then the part may be defective. Replace it.	4.3 POWER SUPPLY BLOCK DIAGRAM
5	Defective parts	-	If the symptom persists after the above corrections,	The DRIVER IC (IC7002) is defective. Replace it.	-
In-focus not possible					
No.	Cause	Diagnostics Point	Item to be Checked	Corrective Action	Reference
1	Defective pickup	SRV Assy	Check the LD current and measure the resistance value of the actuator.	Refer to the "5.3 Failure Judgment of the Pickup Assy."	5.3 Failure Judgment of the Pickup ASSY
2	Defective power supply	SRV Assy	Check the power voltages (V+7R5, V+5D, V+3D, V+3A, V+1R5 and VHALF).	For any power-supply section that does not output the voltage, check the mounting statuses of the regulator IC and its peripheral parts. If they are properly mounted, then the parts may be defective. Replace them.	4.3 POWER SUPPLY BLOCK DIAGRAM
3	Signal errors	SRV Assy	Check that the MUTE1 signal becomes H after loading is completed.	DRIVER IC (IC7002) and SODC (IC7008) may be improperly soldered or defective. Resolder them, if necessary. If the symptom persists, replace SODC (IC7008).	10.1 SRV ASSY(1/2)
4	Signal errors	Traverse mechanism	Check that the spindle motor is rotating at a speed of 2,000 rpm. (A rotation speed of 2,000 rpm is required for focusing in.)	If it does not rotate, see [The spindle motor does not rotate.] in this section.	-
5	Signal errors	SRV Assy	Check that 18 pulses are generated per rotation in the SPDLFG signal.	If the signal is output, check the mounting status of the FEP (IC7004) terminal. If it is properly mounted, then the part may be defective. Replace it. If the signal is not output, check the mounting status of the SODC (IC7008) terminal. If it is properly mounted, then the part may be defective. Replace it.	10.1 SRV ASSY(1/2) 10.15 WAVEFORMS ⑬
6	Signal errors	SRV Assy	Check the FE signal. (Check that an S-shaped signal is output when a waveform of the FEDRV signal is rising after it drops down from 1.65 V.)	If the output waveform is proper, check the mounting status of the SODC (IC7008) terminal. If it is properly mounted, then go to [7]. If the output waveform is not proper, check the mounting status of the FEP (IC7004) terminal. If it is properly mounted, then the part may be defective. Replace it.	10.1 SRV ASSY(1/2) 10.15 WAVEFORMS ⑤
7	Signal errors	SRV Assy	Check that the FEDRV signal fluctuates with 1.65 V at the center.	If the output waveform is proper, check the mounting status of the DRIVER IC (IC7002) terminal. If it is properly mounted, then the part may be defective. Replace it. If the output waveform is not proper, check the mounting status of the SODC (IC7008) terminal. If it is properly mounted, then the part may be defective. Replace it.	10.1 SRV ASSY(1/2) 10.15 WAVEFORMS ⑥
8	Defective parts	SRV Assy	If the symptom persists after the above corrections,	Replace the parts in the order of (1) FEP (IC7004), (2) SODC (IC7008), (3) DRIVER IC (IC7002), (4) SRV Assy, then (5) traverse mechanism.	-
No tracking close					
No.	Cause	Diagnostics Point	Item to be Checked	Corrective Action	Reference
1	-	Traverse mechanism	Check that focusing is in. (If focusing is out, tracking close is not possible.)	See "In-focus not possible" above.	-
2	Signal errors	SRV Assy	Check that the E and F signals fluctuate with 2.2 V at the center.	If no signal is output, check the mounting status of the CN7001 connector. If soldering is improper, resolder it. If the symptom persists after this correction, replace the traverse mechanism.	10.1 SRV ASSY(1/2) 10.15 WAVEFORMS ⑭, ⑮
3	Signal errors	SRV Assy	Check that the TE signal fluctuates with 1.65 V at the center.	If the output waveform is proper, check the mounting status of the SODC (IC7008) terminal. If it is properly mounted, then go to [4]. If the output waveform is not proper, check the mounting status of the FEP (IC7004) terminal. If it is properly mounted, then the part may be defective. Replace it.	10.1 SRV ASSY(1/2) 10.15 WAVEFORMS ⑦
4	Signal errors	SRV Assy	Check that the TEDRV signal fluctuates with 1.65 V at the center, and that a pulse-like signal is output during tracking close.	If the output waveform is proper, check the mounting status of the SODC (IC7008) terminal. If it is properly mounted, then the part may be defective. Replace it. If the output waveform is not proper, check the mounting status of the DRIVER IC (IC7002) terminal. If it is properly mounted, then the part may be defective. Replace it.	10.1 SRV ASSY(1/2) 10.15 WAVEFORMS ⑩
5	Defective parts	SRV Assy	If the symptom persists after the above corrections,	Replace the parts in the order of (1) FEP (IC7004), (2) SODC (IC7008), (3) DRIVER IC (IC7002), (4) SRV Assy, then (5) traverse mechanism.	-

[10-3] If any problem is generated during upgrading of the software

If upgrading fails, an error indication will be displayed on the FL display.

No.	Cause	Diagnostics Point	Item to be Checked	Corrective Action	Reference
1	Upgrading fails	-	Symptoms that may appear when the unit is turned on after upgrading failed: <ul style="list-style-type: none"> If the files for upgrading are invalid: The unit will start up in the normal manner. If the upgrading process fails during the process for the MAIN CPU: "E-7024" will be displayed. If the upgrading process fails during the process for the GUI: Nothing will be displayed. If the upgrading process fails during the process for the PANEL: "E-7022" will be displayed. If the upgrading process fails during the process for the DRIVE: "E-7001" will be displayed. 	Refer to the "6. SERVICE MODE."	6.SERVICE MODE [4] Error display list [7] Firmware update

[11] Error Codes

How to respond when an error code is displayed on the FL DISPLAY is described below.

E-7001: DISC DRIVE ERROR

• The ATAPI drive does not work properly.

No.	Cause	Diagnostics Point	Item to be Checked	Corrective Action	Reference
1	Defective power supply	SRV Assy	Check the power voltages (V+7R5, V+5D, V+3D, V+3A and V+1R5D) in the SRV Assy.	If no power is supplied, check the mounting statuses of the regulator ICs (IC7003/IC7005/IC7007) and their peripheral parts. If soldering is improper, resolder it. If the symptom persists after this correction, replace the parts.	4.3 POWER SUPPLY BLOCK DIAGRAM
2	Loose connection	SRV Assy	Check the connections of the signal line of ATA_RESET.	If the connection is properly made and the signal is output from the MAIN CPU (IC101,) then the port on the SODC (IC7008) may be damaged. Replace it. If the connection is properly made but the signal is not output from the MAIN CPU (IC101,) then the MAIN CPU (IC101) may be damaged. Replace it.	10.1 SRV ASSY(1/2)
3	Clock signal error	SRV Assy	Check that the clock signal (16.9344 MHz) is input to SODC(IC7008).	If no clock signal is output, check the mounting status of the OSC (X7001) and its peripheral chips. If they are properly mounted, then the parts may be defective. Replace them.	10.1 SRV ASSY(1/2)
4	Signal errors	SRV Assy	Check the communication waveforms of SODC (IC7008) and FLASH ROM IC (IC7006).	If there is any waveform that does not change between H and L, communication between the FLASH ROM IC (IC7006) and SODC (IC7008) may not be established. Check their mounting statuses. If soldering is improper, resolder them.	10.1 SRV ASSY(1/2)
5	Defective parts	SRV Assy	If the symptom persists after the above corrections,	Replace the SRV Assy.	-

E-7010: DSP DEVICE ERROR

• The program cannot be written to the DSP (IC501) when the unit is turned on.

No.	Cause	Diagnostics Point	Item to be Checked	Corrective Action	Reference
1	Defective power supply	MAIN Assy	Check the power voltages (V+3R3_DSP and V+1R2_DSP) of DSP (IC501).	If power is not supplied, check the connections of the power line. If V+3R3E is supplied, go to [2]. If V+3R3E is not supplied, go to [3].	
2	Defective clock signal	MAIN Assy	Check that the clock signal (16.394 MHz) is input to DSP (IC501).	If it is not, the crystal oscillator (X503) and their peripheral chips may be defective or their mounting statuses may be improper. Resolder the parts. If the symptom persists after this correction, replace the parts.	10.4 MAIN ASSY(2/3)
3	Defective power supply	MAIN Assy	Check the power voltages (V+3R3_DSP) of SDRAM (IC505) for DSP (IC501).	If power is not supplied, check the connections of the power line. If V+3R3E is supplied, go to [2]. If V+3R3E is not supplied, go to [3].	-
4	Signal errors	MAIN Assy	Check that the DSP710_RST signal that is input to the DSP (IC501) is "H."	If it is not "H," check the mounting status of the pull-up resistor (R526). If it is properly mounted, then the mounting status of the IC123 may be improper. Resolder it. If the symptom persists after this correction, replace it.	10.4 MAIN ASSY(2/3) 10.3 MAIN ASSY(1/3)
5	Signal errors	MAIN Assy	Check the connection of bus line between the DSP (IC501) and SDRAM (IC505).	If the waveform is not proper, check the mounting status of the SDRAM (IC505) and the connections of the BUS lines. If no problem is found, replace the parts.	10.4 MAIN ASSY(2/3)

E-7020: USB-B DEVICE ERROR**• The USB-B controller does not work properly.**

No.	Cause	Diagnostics Point	Item to be Checked	Corrective Action	Reference
1	Defective power supply	MAIN Assy	Check the power voltage (V+3R3_USB_IO) of USB_B CONTROLLER (IC1101).	If power is not supplied, check the connections of the power line. If V+3R3E is supplied, go to [2]. If V+3R3E is not supplied, go to [3].	-
2	Signal errors	MAIN Assy	Check that the USB_RST signal that is input to the USB_B CONTROLLER (IC1101) is "H."	If it is not "H," check the mounting status of the pull-up resistor (R1110). If it is properly mounted, then the mounting status of the IC123 may be improper. Resolder it. If the symptom persists after this correction, replace it.	10.5 MAIN ASSY(3/3), USBA ASSY 10.3 MAIN ASSY(1/3) 10.15 WAVE-FORMS ⑦
3	Defective parts	MAIN Assy	Check the mounting status of the USB_B CONTROLLER IC (IC1101).	If it is properly mounted, then replace the USB_B CONTROLLER (IC1101).	10.5 MAIN ASSY(3/3), USBA ASSY

E-7021: PHY DEVICE ERROR**• ETHER PHY CHIP (IC1304) does not work properly.**

No.	Cause	Diagnostics Point	Item to be Checked	Corrective Action	Reference
1	Defective power supply	MAIN Assy	Check the power voltage (V+3R3_ETH) of ETHER PHY CHIP (IC1304).	If power is not supplied, check the connections of the power line. If V+3R3E is supplied, go to [2]. If V+3R3E is not supplied, go to [3].	-
2	Clock signal error	MAIN Assy	Check that the clock signal (25 MHz) is input to ETHER PHY CHIP (IC1304).	If it is not, the crystal oscillator (X1302) and their peripheral chips may be defective or their mounting statuses may be improper. Resolder the parts. If the symptom persists after this correction, replace the parts.	10.5 MAIN ASSY(3/3), USBA ASSY 10.15 WAVE-FORMS ⑩, ⑨
3	Signal errors	MAIN Assy	Check that the ETHER_RST signal that is input to the ETHER PHY CHIP (IC1304) is "H."	If it is not "H," check the mounting status of the pull-up resistor (R1390). If it is properly mounted, then the mounting status of the IC123 may be improper. Resolder it. If the symptom persists after this correction, replace it.	10.5 MAIN ASSY(3/3), USBA ASSY 10.3 MAIN ASSY(1/3) 10.15 WAVE-FORMS ⑦
4	Defective parts	MAIN Assy	Check the mounting status of the ETHER PHY CHIP (IC1304).	If it is properly mounted, then replace the ETHER PHY (IC1304).	10.5 MAIN ASSY(3/3), USBA ASSY

E-7022: PANEL CPU ERROR**• PANEL CPU (IC8005) does not work properly.**

No.	Cause	Diagnostics Point	Item to be Checked	Corrective Action	Reference
1	Defective power supply	DFLB Assy	Check the power voltage (V+3R3E) of PANEL CPU (IC8005).	If power is not supplied, check the connections of the power line. If V+3R3E is supplied, go to [2]. If V+3R3E is not supplied, go to [3].	4.3 POWER SUPPLY BLOCK DIAGRAM
2	Clock signal error	DFLB Assy	Check that the clock signal (15.975 MHz) is input to PANEL CPU (IC8005).	If it is not, the crystal oscillator (X8001) and their peripheral chips may be defective or their mounting statuses may be improper. Resolder the parts. If the symptom persists after this correction, replace the parts.	10.7 DFLB, ENCB ASSY 10.15 WAVE-FORMS ⑤
3	Defective power supply	DFLB Assy	Check the power voltage (V+12EUP) of DFLB Assy.	If V+12EUP is output, check the mounting statuses of the IC8010 and its peripheral parts. If they are properly mounted, then the parts may be defective. Replace them. If V+12EUP is not output, check the connections of the power line.	4.3 POWER SUPPLY BLOCK DIAGRAM
4	Signal errors	DFLB Assy	Check the communication waveforms. PNL_SCLK2 PNL_BUSY PNL_TXD2 PNL_RXD2	If the waveforms are not proper, check the connections of the communication line. If the PNL_SCLK2 waveform is not proper, check the mounting statuses of the IC8001 and IC8002 and their peripheral parts. If the PNL_TXD or PNL_RXD waveform is not proper, check the mounting statuses of the IC8003 and its peripheral parts.	4.2 SIGNAL BLOCK DIAGRAM 10.7 DFLB, ENCB ASSY
5	Defective parts	DFLB Assy	If the symptom persists after the above corrections,	Replace the PANEL CPU (IC8005).	-

E-7024: MAIN CPU ERROR**• C/FLASH IC (IC114) does not work properly.**

No.	Cause	Diagnostics Point	Item to be Checked	Corrective Action	Reference
1	-	MAIN Assy	First, whether the cause is attributable to the MAIN CPU (IC101) or to the SDRAM (IC108/109) must be distinguished at the status check (alarm) port.	If the MAIN CPU (IC101) is in failure, go to [2]. If the SDRAM (IC108/109) is in failure, go to [4].	6. SERVICE MODE [6] Output of the alarm port
2	Defective power supply	MAIN Assy	Check the power voltage (V+1R2) of MAIN CPU (IC101).	If power is not supplied, check the connections of the power line. If V+3R3E is supplied, go to [2]. If V+3R3E is not supplied, go to [3].	4.3 POWER SUPPLY BLOCK DIAGRAM
3	Clock signal error	MAIN Assy	Check the waveform of system clock (26.965 MHz) is input to MAIN CPU (IC101).	If it is not, the crystal oscillator (X105) and their peripheral chips may be defective or their mounting statuses may be improper. Resolder the parts. If the symptom persists after this correction, replace the parts.	10.3 MAIN ASSY(1/3) 10.15 WAVEFORMS ㉔
4	Signal errors	MAIN Assy	Check that the signals of the CPU_RST line is H.	If it is not "H," check the mounting status of the pull-up resistor (R159). If it is properly mounted, then the mounting status of the RESET IC (IC102) may be improper. Resolder it. If the symptom persists after this correction, replace it.	10.3 MAIN ASSY(1/3)
5	Defective power supply	MAIN Assy	Check the power voltage (V+3R3_CPU) of SDRAM (IC108 and IC109).	If power is not supplied, check the connections of the power line.	-
6	Clock signal error	MAIN Assy	Check that the CPU_CLKOUT signal (108 MHz) is output from the MAIN CPU (IC101) and then input to the SDRAM (IC108/109).	Check that the CPU_CLKOUT signal is input to the SDRAM (IC108/109). If it is input, check the mounting statuses of the SDRAM (IC108/109). If they are properly mounted, then the parts may be defective. Replace them. If the signal is not input, check the connections for the CPU_CLKOUT signal.	10.3 MAIN ASSY(1/3)
7	Defective parts	MAIN Assy	Check the mounting status of the SDRAM(IC108/109).	If it is properly mounted, then replace the MAIN CPU (IC101).	10.3 MAIN ASSY(1/3)

E-7201: TOC READ ERROR**• TOC data cannot be read from a disc.**

No.	Cause	Diagnostics Point	Item to be Checked	Corrective Action	Reference
1	-	Traverse mechanism	Measure the error rate in Player Operation mode of Service mode in order to distinguish whether the cause is attributable to the disc or to the player. For measurement, play back the reading point at which reading resulted in an error, by listening to the sound.	See [10] SERVICE MODE for details.	"[10]SERVICE MODE" of this section

E-8709: COMMUNICATION ERROR**• Communication between the PANEL CPU (IC8005), GUI CPU (IC4002) and MAIN CPU (IC101) is not possible.**

No.	Cause	Diagnostics Point	Item to be Checked	Corrective Action	Reference
1	-	MAIN Assy /DFLB Assy	Check the connections of communication line between the MAIN CPU (IC101) and PANEL CPU (IC8005) and GUI CPU (IC4002).	If connection is improper, resolder it.	4.2 SIGNAL BLOCK DIAGRAM

5.3 FAILURE JUDGEMENT OF THE PICKUP ASSY

● LD power after passing through the objective lens [mW]

SPEC: 0.147 ± 0.02

Check method: Measure the LD power, using an optical power meter.

Failure judgment: A value out of the range of the specifications is judged as failure.

● Actuator resistance value [ohms]

Specifications on the focus side: 3.4 ± 0.5

Specifications on the tracking side: 4.1 ± 0.6

Check method: Disconnect* the FFC connected to the CN7001 on the focus side then measure the resistance value between FFC pins 23 and 24.

Disconnect* the FFC connected to the CN7001 on the tracking side then measure the resistance value between FFC pins 21 and 22.

*Short-circuit the LD short-circuit pad.

Failure judgment: A value out of the range of the specifications is judged as failure.

● LD current [mA]

SPEC: TYP70 MAX80

Check method: Measure the LD current at the probe pad on the SRV Assy, using a tester.

[Check procedure]

1. For details on how to emit light from the LD, see the description on Drive Operation in Service mode.
 2. With the LD OFF, apply the probes of a tester to the reference probe pad. (V+5 and LDI, see Fig. 1.)
- Note:** Be careful not to apply the probes to the pads with LD ON. If you do so, the LD may be damaged.
3. With the probes applied to the above-mentioned pads, turn the LD ON to measure the voltage between them.
 4. After measurement, turn the LD OFF (ALL OFF) then pull the probes away.
 5. Divide the measured voltage value by 12 ohms (resistance value), and calculate current value.

Failure judgment: If the calculated current value exceeds the maximum value, the LD has been degraded

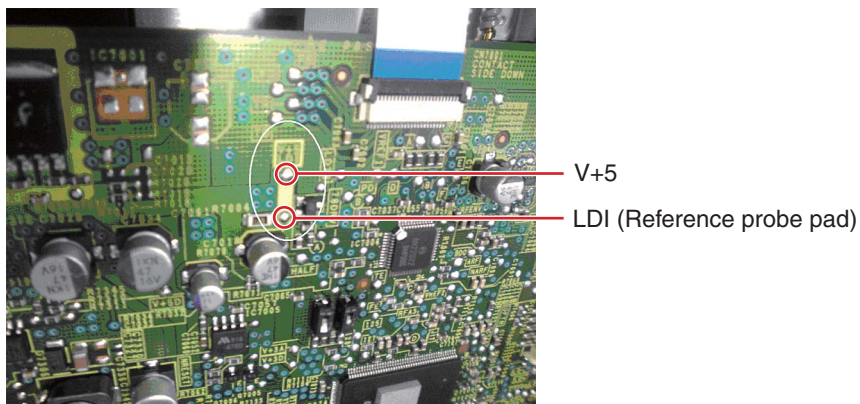

Fig. 1 SRV Assy

5.4 CONNECTION CHECK WITH THE PC

[1. USB B connector]

Whether communication between the PC connected via the USB B connector and this unit is properly performed or not can be confirmed on the PC.

Note: Installation of the driver software is not necessary.

■ Use Device Manager for checking.

If the PC and this unit are properly connected, the components of this unit are added in Device Manager (under Hardware) as devices.

If all components are properly displayed, the PC and this unit are properly communicating via the USB connector.

In a case of Windows XP:

Start, Control Panel, System, Hardware, then Device Manager

Devices to be added:

Universal Serial Bus controllers

USB Composite Device

Under “Sound, video and game controllers”

USB Audio Device

Human Interface Devices

HID-compliant device

USB Human Interface Device

A communication check may be easily performed if connection is made with Device Manager displayed on the PC screen.

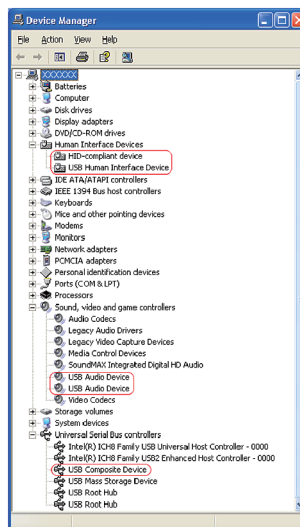

[2. LINK]

Whether communication between the PC connected via the LINK connector and this unit is properly performed or not can be confirmed on this unit.

Note: Use a Category 5 cable or a cable with higher specifications for connection.

Either a straight or cross LAN cable can be used when the unit is directly connected with the PC, but when the unit is connected with the PC via a hub, be sure to use a straight cable.

■ Use the MENU/UTILITY key of this unit to check linkage.

The linkage between the PC and this unit can be confirmed with LINK STATUS under [MENU/UTILITY].

How to display LINK STATUS

1. Hold the MENU/UTILITY key pressed for at least 1 sec.

The [UTILITY] screen will be displayed.

2. Select LINK STATUS, using the rotary selector.

3. With LINK STATUS selected, connect the PC and this unit, using the LINK cable.

4. Check the LINK STATUS display.

	① Not connected	② While connection is being made	③ When connected properly
Indication	NOT CONNECT	CONNECTING	CONNECTED

If the indication changes from ① to ② then ③, the link is properly established.

If the cable is disconnected, the indication returns to ①.

5. After checking is completed, press the MENU/UTILITY key.

The screen displayed before the MENU/UTILITY key was pressed will be restored

6. SERVICE MODE

6.1 OUTLINE OF THE SERVICE MODE

The following service modes are prepared for this unit.

- ① Confirmation of the button input and an indication function.
It is the mode which checks each input and display function of a button, a JOG dial, the slider volume, and an encoder.
- ② Check mode of the load of JOG dial.
It is the mode which measures the load when rotating JOG dial.
- ③ Indication of various information
It is a mode displaying information such as a version and an error history, a device normal / abnormality judgment.
- ④ Error display list
An error code and the contents are shown.
- ⑤ Confirmation of movement of the drive unit
It is the mode which checks operation of a mechanism and servo of drive unit.
- ⑥ Output of the alarm port
Explanation of the meaning of output of status terminal on a MAIN Assy.
- ⑦ Firmware update.
Explanation of the method of firmware update.

6.2 ABOUT THE DEVICE OF CDJ-900

Device Name	Function	Part No.	Ref No.	Assy
MAIN CPU	Main control	R5S77641N300BG	IC101	MAIN Assy
FLASH	Memory for MAIN CPU (Firmware)	DYW1775	IC114	MAIN Assy
SDRAM	Memory for MAIN CPU (Work)	K4S561632J-UC75	IC108, IC109	MAIN Assy
DSP	Audio DSP	D710E001BZDHA275	IC501	MAIN Assy
SDRAM	Memory for DSP (Work)	K4S561632J-UC75	IC505	MAIN Assy
USB_B CONTROLLER	CONTROLLER for USB-B (function)	M66291GP	IC1101	MAIN Assy
ETHER PHY	PHY for LINK	RTL8201CP-LF	IC1304	MAIN Assy
GUI CPU	LED, DATA_FL, & BROWSE_FL control	R5F363AENFA-U0	IC4002	BFLB Assy
PANEL CPU	Button input, LED & JOG_FL control	M3030RFCPPFP	IC8005	DFLB Assy
SODC	Disc drive control	MN103S71F	IC7008	SRV Assy
FLASH	Memory for DRIVE CONTROLLER	DYW1776	IC7006	SRV Assy

Two or more FLASH and SDRAM are mounted in the main body.

Please diagnose it after confirming whether it is a device that agrees with purpose again.

6.3 DETAILS ON SERVICE MODE

A

[1] Confirmation of the button input and an indication function

When it spends a power supply while pushing a TEMPO button and a MEMORY button simultaneously, It is displayed in the BROWSE_FL, "SERVICE MODE", and enters into this mode. (Please continue pushing until "Pioneer LOGO"screen disappears.)

When it enters this mode, the TAG-TRACK button is pushed, and the screen is sent as follows, the following status displays are done.

In this mode, the input of each button, JOG, volume, etc. is normal, and it can check that a display can also be performed normally. In addition, indication turns on while I push a button.

Caution: In this status display, if a VINYL SPEED ADJUST VOLUME is turned to the limit of the right, it will shift to "the load measurement mode of JOG." (Refer to the following clause.)

B

BROWSE_FL

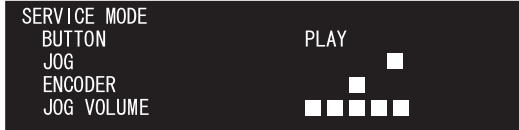

- BUTTON : The pushed button name is displayed.
- JOG : The point moves according to the direction that JOG turned.
- ENCODER : The point moves according to the direction that ENCODER switch turned.
- TEMPO SLIDER VOLUME : If a TEMPO slider knob is moved to the - side, a bar display will increase.
- JOG VOLUME : If a VINYL SPEED ADJUST VOLUME is turned to the right, a bar display will increase.

DATA_FL



C

D

E

F

Button, Switch	Light up LED	Status display of BROWSE_FL(BUTTON)	Other Displays
PLAY/PAUSE	PLAY/PAUSE	PLAY	
CUE	CUE	CUE	
IN/CUE/IN ADJUST	IN/CUE/IN ADJUST	IN	
OUT/OUT ADJUST	OUT/OUT ADJUST	OUT	
RELOOP/EXIT	RELOOP/EXIT	RELOOP	
TRACK REV (◀◀)		PREVIOUS ◀◀	
TRACK FWD (▶▶)		NEXT ▶▶	① (Refer to the display pattern of JOG FL)
SEARCH REV (◀◀)		REV ◀◀	② (Refer to the display pattern of JOG FL)
SEARCH FWD (▶▶)		FWD ▶▶	⑤ (Refer to the display pattern of JOG FL)
JOG MODE	VINYL	JOG MODE	④ (Refer to the display pattern of JOG FL)
TEMPO	STANDBY	TEMPO RANGE	
MASTER TEMPO	MASTER TEMPO	MASTER TEMPO	
TIME MODE/AUTO CUE		TIME/ACUE	
DELETE	All LED lights up	DELETE	All JOG-FL lights up
MEMORY		MEMORY	
EJECT	EJECT	EJECT	
CUE/LOOP CALL ◀		◀ CALL	
CUE/LOOP CALL ▶		CALL ▶	
JOG TOUCH	JOG TOUCH	JOG TOUCH SW	③ (Refer to the display pattern of JOG FL)
AUTO BEAT LOOP 1	AUTO BEAT LOOP 1	AUTO LOOP 1	
AUTO BEAT LOOP 2	AUTO BEAT LOOP 2	AUTO LOOP 2	
AUTO BEAT LOOP 4	AUTO BEAT LOOP 4	AUTO LOOP 4	
AUTO BEAT LOOP 8	AUTO BEAT LOOP 8	AUTO LOOP 8	
BEAT SELECT	AUTO BEAT LOOP (LEFT)	BEAT SELECT	
SLIP	AUTO BEAT LOOP (RIGHT)	SLIP	
TEMPO SLIDER			Increase and decrease (■ MARK of DATA_FL)
JOG (FWD)		JOG ■ MARK Right movement (10 points by one rotation)	
JOG (REV)		JOG ■ MARK Left movement (10 points by one rotation)	
VINYL SPEED ADJUST VOLUME		JOG VOLUME ■ MARK Increase and decrease (10 points)	"It becomes "Measurement of the JOG dial load" mode if it turns to the right completely.
DIRECTION (Reverse)	REV	REV	
USB_STOP_SW (ON)	USB Access	USB STOP	
LINK	LINK	LINK	
USB	USB	USB	
DISC	DISC	DISC	
BROWSE	BROWSE	BROWSE	
TAG LIST	TAG LIST	TAG LIST	
INFO	INFO	INFORMATION	
MENU	MENU	MENU	
BACK			Display pattern changes(Refer to the display pattern of BROWSE_FL)
TAG TRACK			
ROTARY SELECTOR (SW)		ENCODER PUSH	
ROTARY SELECTOR (FWD ROTATE)		ENCODER ■ MARK Right movement (Max 10 points)	
ROTARY SELECTOR (REV ROTATE)		ENCODER ■ MARK Left movement (Max 10 points)	

A

Display pattern of JOG FL



B

C

The display pattern of BROWSE_FL

When I push the TAG-TRACK button from above status indication more and send a screen, I display three kinds of patterns to BROWSE_FL as follows.

If the BACK button is pushed, a display will return a previous page.

(In DATA_FL, it becomes all putting out lights except the case of all-points light.)

D

Lattice pattern

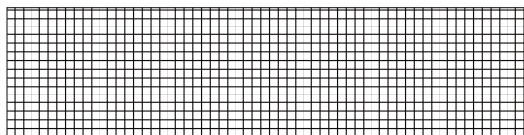

All turning off



E

All turning on



F

[2] Check mode of the load of JOG dial

Measurement

It is the mode which judges the load (light/heavy) when rotating JOG dial numerically objective.

It goes into "[1] Confirmation of the button input and a indication function", and it will become this mode if a VINYL SPEED ADJUST VOLUME is turned to the limit of the right.

It goes into this mode, and a number will be displayed if JOG dial is turned with sufficient vigor.

The rotation direction -- right-handed rotation and left-handed rotation -- either is O.K.

The meaning of the numerical value displayed is as follows.

TOP SPEED: Top speed (let the time of turning one rotation in 1.8 second be 1 speed)

TIME: Time taken for rotation to fall to 1.5 speed from 3 speed

It is necessary to make it rotate top speed to 7.0 or more times to measure the rotation fall time required. Not more than 7.0 times faster in the display "00M:00S 00.0F " to be flashing a warning.

In addition, when it carries out continuously several times, about time, 2nd henceforth takes and displays an average of a maximum of 99 times.

Measurement which absorbed variation by this can be performed.

BROWSE_FL

SERVICE MODE	JOG LOAD	OK
1. 8.96 150	4. — —	
2. 9.57 153	5. — —	
3. — —	AVR. 9.26 151	

Input data twice.

DATA_FL

00 00:00:00

2

The numerical value written to the right end shows the number of times of an input.

BROWSE_FL

SERVICE MODE	JOG LOAD	OK
1. 8.96 150	4. 9.57 147	
2. 9.57 153	5. 9.92 150	
3. 9.57 156	AVR. 9.51 151	

Input data 5 times.

DATA_FL

00 00:00:00

5

BROWSE_FL

SERVICE MODE	JOG LOAD	OK
6. 8.68 153	9. 10.28 147	
7. 9.57 156	10. 9.57 156	
8. 7.12 153	AVR. 9.28 152	

Input data 10 times.

Measurement to 99 times and calculation of average value can be performed by the highest.

DATA_FL

00 00:00:00

10

Judgment result

If time is in a certain uniformity range, I display it with "OK" in the line of title, but display "NG" if I do not enter. This judgment value is 170 ± 20 msec.

Record of a judgement

If USB memory is inserted and MASTER TEMPO button is pushed, a measurement result can write out as a CSV file of the name "JOGLOAD_900.CSV."

In addition, data is added whenever it pushes MASTER TEMPO button.

Moreover, the MAC address is filled in as solid identification.

NO.	TOP SPEED	TIME(msec)
1	7.71	138
2	8.17	138
3	7.61	138
4	9.25	141
5	8.81	135
6	8.41	138
7	8.68	141
8	7.12	141
9	8.17	138
10	8.68	135
11	8.17	138
12	8.54	132
13	7.82	135
AVR	8.24	137(NG)

(judge : 150ms <= Time <= 190ms)

A [3] Indication of various information

If a power supply is switched on, pushing "TEMPO" "CUE/LOOP CALL ◀" button simultaneously with a button, it will be displayed on FL display part as "SERVICE MODE", and will go into this mode.

(Please continue pushing until "Pioneer LOGO" screen disappears.)

It goes into this mode, and if a TAG-TRACK button is pushed and a screen is sent, the contents of a display will change as follows. Moreover, it can return with BACK button.

① Version information

■ BROWSE_FL

SERVICE MODE	VERSION INFO
MAIN 1.00	DRIVE 1.00
GUI 1.00	
PANEL 1.00	MAC ADDRESS
DSP 1.00	00E03600D22C

The version number of CPU/microcomputer carried in this machine is displayed.
The MAC Address of Ethernet simultaneously built in this machine is also displayed.

MAIN : The CPU which controls a main
GUI : The Microcomputer which controls LED, DATA_FL, & BROWSE_FL.
PANEL : The microcomputer which controls a button input, LED & JOG_FL.
DSP : Audio DSP
DRIVE : The controller which controls a disc drive.

■ DATA_FL

② Error history

■ BROWSE_FL

SERVICE MODE	ERROR HIST (1/2)
1. E-8301 CD	5. E-8303 CD
2. E-8302 CD	6. E-8304 CD
3. E-8304 USB	7. E-9101
4. E-8302 CD	8. E-8302 CD

■ BROWSE_FL

SERVICE MODE	ERROR HIST (2/2)
9. E-8302 CD	13. E-8301 CD
10. E-8304 USB	14. E-8302 CD
11. E-8301 CD	15. E-8303 CD
12. E-8302 CD	16. E-9101

■ DATA_FL

■ DATA_FL

16 pieces are divided into two screens and the error history generated in the past is displayed. "1" becomes the newest error code.
The 16 newest pieces are displayed.

The screen is selected with the BACK button or TAG TRACK button.

Moreover, the item which follows an error code expresses a media. (The error which is not related to media is blank.)

USB : USB device (MEMORY/HDD)

CD : DRIVE - CD media (CDDA/CD-ROM)

About contents of an error code, please refer to "[4] Error display list".

③ Auto device diagnosis

■ BROWSE_FL

SERVICE MODE	AUTO DEV	CHECK
GUI OK	USB CONT	OK
PANEL OK	PHY CHIP	OK
DSP OK		
DRIVE OK		

The result which judged normal/abnormalities of each device is displayed at the time of power supply ON and initialization.

GUI : The Microcomputer which controls LED, DATA_FL, & BROWSE_FL.
PANEL : The microcomputer which controls a button input, LED & JOG_FL.
DSP : Audio DSP
DRIVE : The controller which controls a disc drive.
USB CONT : USB DEVICE (Type B) controller
PHY CHIP : The controller which controls the physical layer of Ethernet.

Please refer to "[6] Output of the alarm port" for details.

[4] Error display list

Time display shows "E-XXXX: DISC DRIVE ERROR".

Note: An alarm port is a function which outputs a pulse from the test port (STATUS TEST POINT) of Main CPU and tells an unusual part by the number of pulses.

Error Code	Display Word	Contents	Remarks	Alarm port correspondence
E-7001	DISC DRIVE ERROR	The ATAPI drive doesn't function normally.		○
E-7010	DSP DEVICE ERROR	The DSP doesn't function normally. The program isn't available for download.		○
E-7020	USB-B DEVICE ERROR	The USB-B controller doesn't function normally.	*	○
E-7021	PHY CHIP ERROR	The ETHER PHY doesn't function normally.	*	○
E-7022	PANEL CPU ERROR	The PANEL CPU doesn't function normally.	* It becomes this error when communication with MAIN CPU & PANEL CPU is not materialized in the abnormalities in wire connection etc. It becomes this error when update of PANEL CPU goes wrong. MAIN CPU detects and an error code is transmitted to GUI CPU.	○
E-7024	MAIN CPU ERROR	The MAIN CPU doesn't function normally.	* It becomes this error when update of MAIN CPU goes wrong. MAIN CPU transmits an error code to GUI CPU by emergency mode.	
E-7101	INTERRUPT EXCEPTION	The abnormalities which are not expected on a MAIN CPU occurred.		
E-7201	TOC READ ERROR	TOC Data can't be read.		
E-8301	PLAYER ERROR	Abnormalities occurred during starting.		
E-8302	PLAYER ERROR	Abnormalities occurred during playback.		
E-8303	PLAYER ERROR	Other abnormalities occurred.		
E-8304	DECODE ERROR	It is the file which cannot be performed normally.		
E-8305	DATA FORMAT ERROR	It is the file which cannot be performed normally.		
E-8306	NO FILE	The registered file does not exist.		
E-8709	COMMUNICATION ERROR	Neither PANEL CPU & GUI CPU nor the communication between MAIN CPU can be done.	* When the communication with MAIN CPU is not materialized by the abnormalities of connection, GUI CPU displays an error code spontaneously. When MAIN CPU does not operate completely, it will be in this mode.	
E-9101	MECHANICAL TIMEOUT	Mechanism operation was not completed within regulation time.		

* New

[5] Confirmation of movement of the drive unit

It is within "[3] Indication of Various Information" mode, and the following control becomes possible when the screen of "⑤ the drive operation/error rate measurement" is chosen.

This mode consists of "player operation mode" and "test operation mode."

<Player operation mode>

Basic operation of Servo, such as setup, play, pause, and track search, is carried out. Moreover, measurement of an error rate can also be performed.

<Test operation mode>

Servo operation is finely controllable gradually.

* It becomes player operation mode and shifts to test operation mode by the key input in the beginning.

* The command treated here is for mainly testing a mechanism and a servo system, and is not for DJ functions, such as scan and tempo.

Function	Main unit button
<Player operation mode>	
Servo All Off (Stop)	TIME
Play(Trace) / Pause	PLAY/PAUSE
Track Search Fwd/Rev	TRACK SEARCH FWD/REV
Error Rate Count	CUE
Eject	EJECT
Mode Change (-> Test operation mode)	MASTER TEMPO
<Test operation mode>	
Servo All Off	TIME
Slider Move Fwd	SEARCH FWD
Slider Move Rev	SEARCH REV
Step command	CUE/LOOP CALL NEXT(▶)
Mode Change (->Player operation mode)	MASTER TEMPO

■ Player operation mode command

Play(Trace) / Pause

If it is in a stop state, it will set up and play. Moreover, if it is in a play state, whenever it will push a button, a pause and a play are carried out by turns.

It is displayed on a drive state display part as "PLAY or PAUSE."

Track number and time under present trace are displayed. (It becomes a display of four times speed.)

Note: In this mode, even if it inserts a disc, an automatic setup is not carried out.

Moreover, a play is not carrying out audio reproduction, but is tracing the signal side of a disk.

Track Search F/R

Search a track displayed by a FWD / REV course and do pause.

It is indicated with [SEARCH] in the drive condition indication part.

Note: A track search is not possible in CD-ROM (MP3/AAC/WAV/AIFF).

Error Rate Count

I measure an error rate from a present position doing a play/pause for about 20 seconds and display a measurement result in FL. Usually, a track to measure is made to search and this button is inputted from a pause state.

For example, it is displayed as "3.56E-4 O.K." etc.

If an error rate is less than 3.00E-3, it will be displayed as O.K. If an error rate is larger than 3.00E-3, it will be displayed as NG.

Measurement with the managed disc at the time of factory shipments is a premise.

The product does not judge whether they are inferior goods at the time of service.

Eject

A disc is ejected. It is indicated with [EJECT] in the indication part.

Mode Change (It shifts to the Test operation mode.)

If the MASTER TEMPO button is pushed into player operation mode, MASTER TEMPO LED will light up, and it will shift to the below-mentioned "test operation mode." It is indicated with [TEST MODE] in the indication part.

A ■ Test operation mode command

Servo operation is finely controllable gradually.

Keep in mind a test operation mode command that it may give a damage to a player as mistaking the usage.

Please operate this mode after making a disc a set completion state.

■ **Note:** Operate it after you take a state of loading in.

Servo All Off

When servo is ON, all servo will be turned off if the TIME button is pushed.

It is indicated with [ALL OFF] in the indication part.

B Slider Move Fwd

You send about 1.8 mm sliders to a circumference direction whenever you push a SEARCH FWD button.

It is indicated with [SLIDER FWD] in the indication part.

Slider Move Rev

You send about 1.8 mm sliders to an internal circumference direction whenever you push a SEARCH REV button.

■ It is indicated with [SLIDER REV] in the indication part.

Step command

Perform the serial movement of the setup by a step.

If a CUE/LOOP CALL NEXT (▶) button is pushed, it will step up (even if it pushes PREV (◀) button, the stripes of the step down are not carried out). Operation and a display of each step are as follows.

C

Step	Action	Indication Part
STEP0 :	Servo All Off	ALL OFF
STEP1 :	Laser diode on	LD ON
STEP2 :	Disc presence judgment	DISC SEARCH
STEP3 :	Spindle on (2000 rpm)	SPINDLE ON
STEP4 :	Disc sense	DISC SENSE
STEP5 :	Focus servo on	FOCUS ON
STEP6 :	Tracking servo on	TRACKING ON
STEP7 :	Focus position coarse adjustment	FOCUS POSITION
STEP8 :	Focus gain adjustment	FOCUS GAIN
STEP9 :	Tracking gain adjustment	TRACKING GAIN
STEP10 :	Address lead start	ADDRESS READ

D

CUE/LOOP CALL NEXT (▶) button : step up

Note: Spindle on rotates by 2000 rpm CAV.

It cuts in the CLV four times speed at the address lead and it changes.

■ Mode Change (The end of the test movement mode)

If the MASTER TEMPO button is pushed into "test operation mode", MASTER TEMPO LED will light out, and it will shift to the above-mentioned "player operation mode." It is indicated with [PLAYER MODE] in the indication part.

E

F

[6] Output of the alarm port

Although "Normal/abnormalities of each device at the time of power supply ON and initialization" can be judged by Auto device diagnosis of a "[3] Indication of various information", the test port output on a main board can also be checked. When a defect is detected by the device by power supply ON, an alarm port (STATUS TEST POINT) performs the following pulse outputs.

		Alarm Port		Service Mode/Auto Device Diagnostic Display		Normal Error Display
		Detection	Remarks	Output Pattern	Display	
MAIN CPU						
Flash (for Main CPU)	x	If Flash is NG, the boot program itself does not operate.		(0.5sHI->0.5sLOW) x once ->2sLOW->Afterward, repetition	x	← If SDRAM is NG, the service program itself does not operate.
SDRAM (for Main CPU)	○				x	
Peripheral with built-in MAIN CPU						
IDE (DRIVE)	○			(0.5sHI->0.5sLOW) x 7 times ->2sLOW->Afterward, repetition	○	E-7001
USB-A	—	Since it is MAIN CPU built-in, it is hard to consider that peripheral one of these becomes out of condition at pinpoint. It cannot judge whether all have fault in the course to a connector.			—	←
LAN					—	
External peripheral						
USB-B CONTROLLER	○			(0.5sHI->0.5sLOW) x 4 times ->2sLOW->Afterward, repetition	○	E-7020
ETHER PHY	○			(0.5sHI->0.5sLOW) x 3 times ->2sLOW->Afterward, repetition	○	E-7021
Device communicated with MAIN CPU						
PANEL CPU	○			(0.5sHI->0.5sLOW) x 5 times ->2sLOW->Afterward, repetition	△	Although detection is possible in communication failure, since it does not put into the service mode, a check is correctly impossible.
DSP	○			(0.5sHI->0.5sLOW) x twice ->2sLOW->Afterward, repetition	○	E-7010
SDRAM (for DSP)	x	If SDRAM is NG, it cannot communicate with Main CPU.			x	←
GUI CPU	○			(0.5sHI->0.5sLOW) x 6 times ->2sLOW->Afterward, repetition	△	Although detection is possible in communication failure, since it cannot display on FL, a check is correctly impossible.
Altogether normal				After 2sHI as LOW		

A ■ Output waveforms of the alarm port

B

C

D

E

F

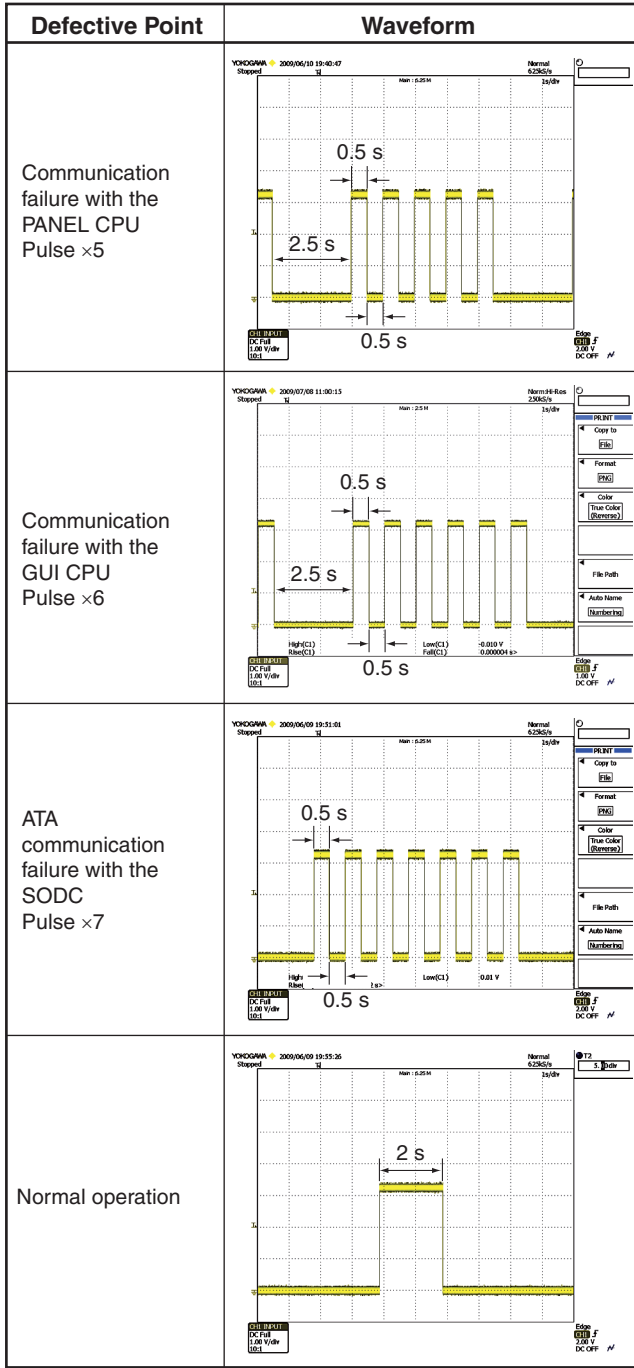
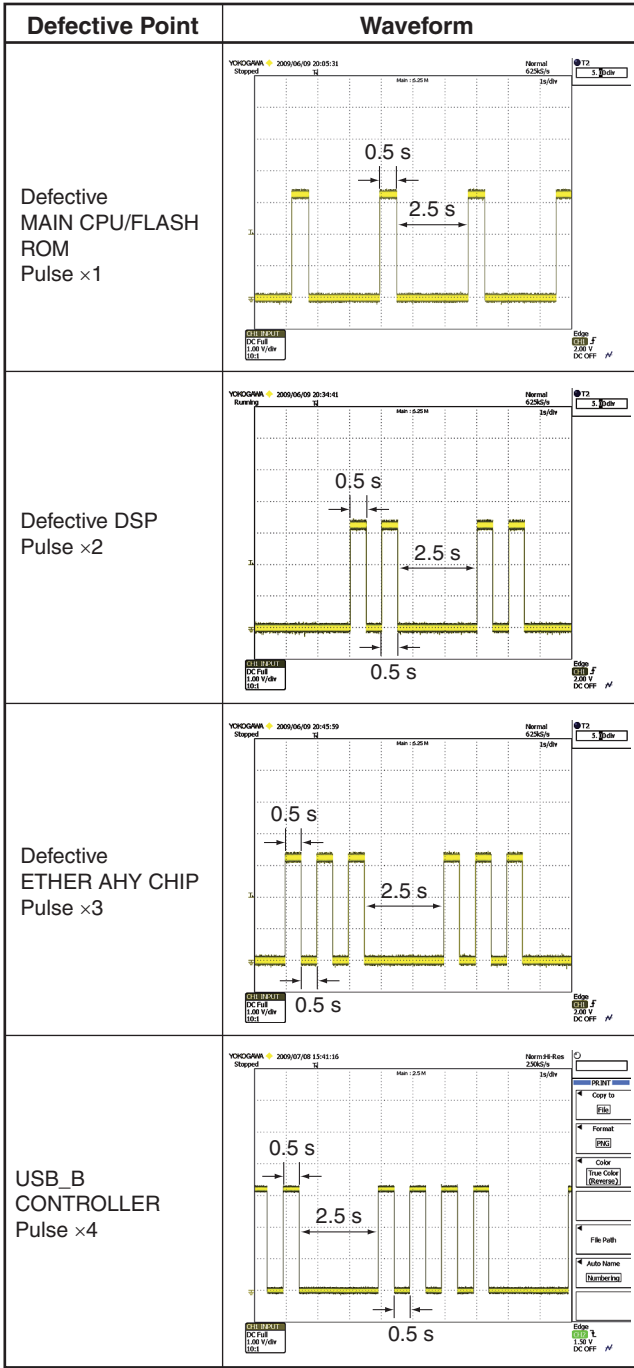

[7] Firmware update

The device and updater file name for update is the following.

	Device	File Name	Remarks
MAIN	Main CPU	C900MAIN.UPD	Motorola formal text
GUI	GUI CPU	C900GUI.UPD	Motorola formal text
PANEL	PANEL CPU	C900PANL.UPD	Motorola formal text
DRIVE	SODC	C900DRIV.UPD	Motorola formal text

A version is not contained in a file name.

Since the character sequence containing a version etc. is added to the head of each file, it can check by the editor, viewer, etc.

■ When USB memory is used

Please use USB memory formatted by FAT/FAT32. It does not correspond to HFS+.

- ① A file to update is copied to USB memory.
(One files will be copied if it is one pieces. Two files will be copied if it is two pieces.)
- ② Please turn on a power supply, pushing both the buttons of MEDIA SELECT/USB and RELOOP.
(Please continue pushing until "Pioneer LOGO" screen disappears.)
It is displayed the message of "Connect a USB storage device to the USB port." , USB memory is inserted in USB port of the front or the back. (If USB memory is put and it goes into the mode, a message will not be displayed but update will start immediately.)
- ③ Update is automatically performed in the order of "GUI -> DRIVE -> MAIN -> PANEL".
The message of "NOW UPDATING" is displayed as follows during update.
And, the status of each microcomputer and each CPU is displayed with AUTO BEAT LOOP-LED.

GUI : AUTO BEAT LOOP[1] File exists = Lighting / Update is progressing = Blinking / Update end = Turning off
(* Approx. 1 minute)

DRIVE : AUTO BEAT LOOP[2] File exists = Lighting / Update is progressing = Blinking / Update end = Turning off
(* Approx. 1 minute)

MAIN : AUTO BEAT LOOP[4] File exists = Lighting / Update is progressing = Blinking / Update end = Turning off
(* Approx. 2 minutes)

PANEL : AUTO BEAT LOOP[8] File exists = Lighting / Update is progressing = Blinking / Update end = Turning off
(* Approx. 1 minute)

* Firmware update time.

AUTO BEAT LOOP

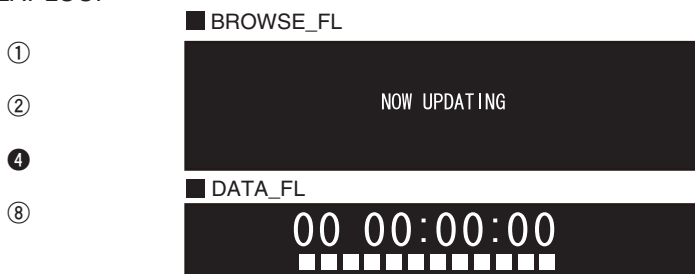

- ④ AUTO BEAT LOOP-LED of the device is turned off when there is no file, and the update is not done.
- ⑤ Since the message of "Firmware update is completed.Turn the power off before using." will be displayed if update is completed, please return on a power supply.

A

■ When CD-R/RW is used

- ① A file to update is copied to CD-R/RW.
(One files will be copied if it is one pieces. Two files will be copied if it is two pieces.)
- ② Please turn on a power supply, pushing both the buttons of MEDIA SELECT/DISC and RELOOP.
(Please continue pushing until "Pioneer LOGO" screen disappears.)
Insert CD-ROM, if the message "Insert CD-ROM disc" is displayed.
- ③ The rest is the same as that of the case where USB memory is used.

B

■ Recovery when failing

When update of each CPU goes wrong and the power supply has been turned off on the way, subsequent normal operation becomes impossible. In this case, the recovery (emergency) mode which only updates operates.
In addition, please carry out by USB memory in recovery. CD-ROM cannot be used.

- ① Failure of a MAIN
When the message of "MAIN firmware update failed." is displayed or the power supply has been turned off on the way, if a power supply is returned on again, the error code of "E-7024: MAIN CPU ERROR" will be displayed.
In this case, update will be possible if it usually carries out again using a passage MEDIA SELECT/USB button and RELOOP button.
In addition, only MAIN is updated even if files other than MAIN are in USB memory.
If the unit cannot be recovered after a retrial of downloading, a part may be defective. Replace the whole MAIN Assy.
(This is because provision of a FLASH ROM in which a specific MAC address has been written is not possible.
For details, see section "1.2 NOTES ON FLASH ROM").

- ② Failure of a GUI
When the message of "GUI firmware update failed." is displayed or the power supply has been turned off on the way, if a power supply is returned on again, the error code of "E-7023: GUI CPU ERROR" will be displayed.
In this case, update will be possible if it usually carries out again using a passage MEDIA SELECT/USB button and RELOOP button.
In addition, if files other than GUI are contained in USB memory, it will usually pass and all they will be updated.
If the unit cannot be recovered after a retrial of downloading, a part may be defective. Replace the IC4002 (GUI CPU).

- ③ Failure of a PANEL
When the message of "PANEL firmware update failed." is displayed or the power supply has been turned off on the way, if a power supply is returned on again, the error code of "E-7022: PANEL CPU ERROR" will be displayed.
In this case, how to the update mode to enter differs from usual.
Please continue pushing a button 10 seconds or more until it turns on a power supply and the message of "Connect a USB storage device to the USB port." is displayed, pushing only a USB-STOP button.
In addition, if files other than PANEL are contained in USB memory, it will usually pass and all they will be updated.
If the unit cannot be recovered after a retrial of downloading, a part may be defective. Replace the IC8005 (PANEL CPU).

- ④ Failure of a DRIVE
When the message of "DRIVE firmware update failed." is displayed or the power supply has been turned off on the way, if a power supply is returned on again, the error code of "E-7001: DISC DRIVE ERROR" will be displayed.
In such a case, the unit cannot be recovered by a retrial of downloading. Replacement of IC7006 (FLASH ROM) is required.

F

5

6

7

8

7. DISASSEMBLY

Note:

(1) Do NOT look directly into the pickup lens. The laser beam may cause eye injury.
 (2) Even if the unit shown in the photos and illustrations in this manual may differ from your product, the procedures described here are common.

Diagnosis of SRV Assy

- (1) Remove the three screws. (BPZ30P080FNI)
- (2) Remove the eight screws. (BBZ30P060FTC)
- (3) Remove the bottom plate.

Bottom plate

• Bottom view → Front

↓

Diagnosis

SRV Assy

• Bottom view → Front

CDJ-900

5

6

7

8

55

Diagnosis of MAIN Assy

[1] Control Panel Section

- (1) Remove the two screws. (BBZ30P060FTB)
- (2) Remove the two screws. (BPZ30P200FTB)
- (3) Remove the five screws. (BPZ30P080FNI)

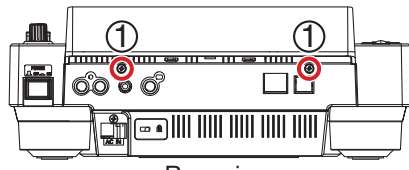

• Rear view

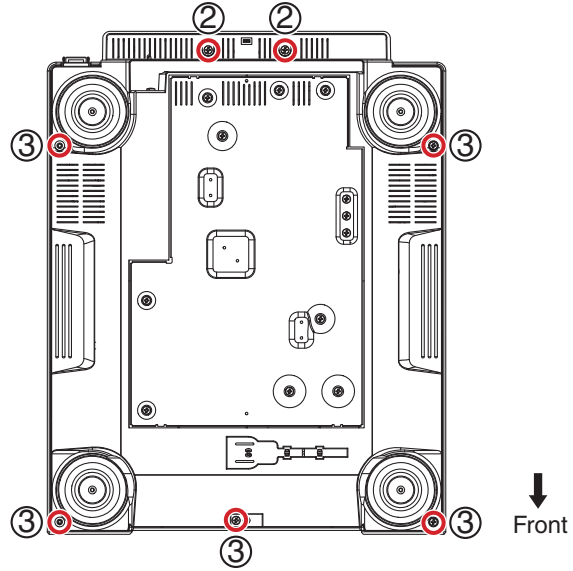

• Bottom view

- (4) Remove the control panel section.
- (5) Disconnect the flexible cable.

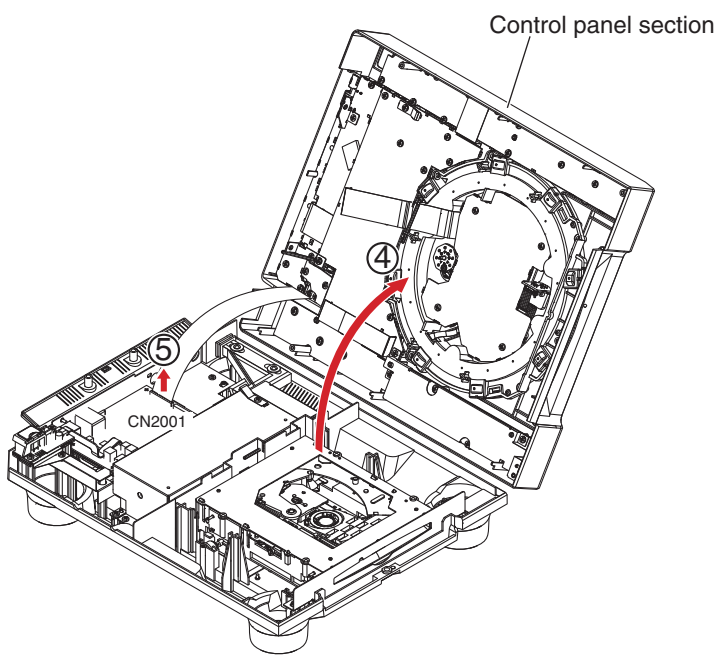

[2] MAIN and JACB Assemblies

(1) Remove the two screws. (BPZ30P080FTB)

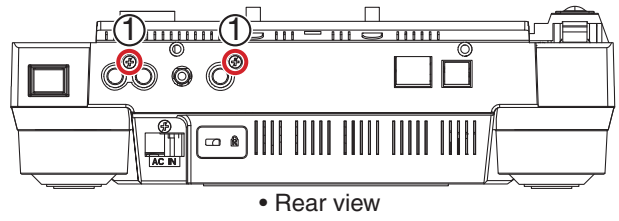

(2) Remove the five screws. (BBZ30P060FTC)

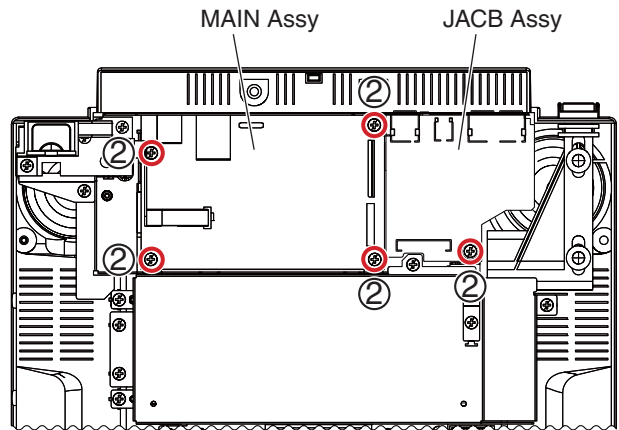

(3) Stand the MAIN and JACB Assemblies.

↓

Diagnosis

Even if you do not lift the PC board, a diagnosis is possible on a part side.

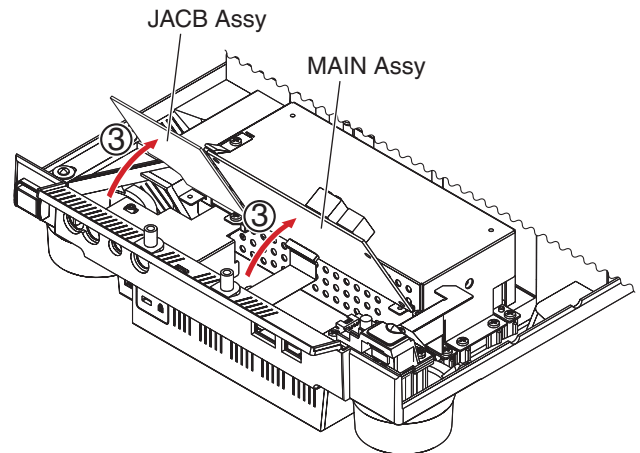

Slotin Mechanism Section

[1] Mecha Plate

- (1) Remove the four screws. (BPZ30P080FNI)
- (2) Remove the mecha plate.

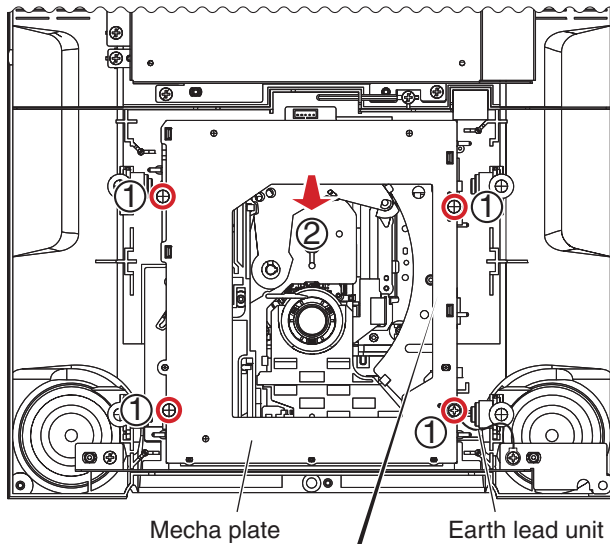

Note of earth spring

- Be sure not to lose it.
- Be careful to the installation places.
- Confirm it by viewing.

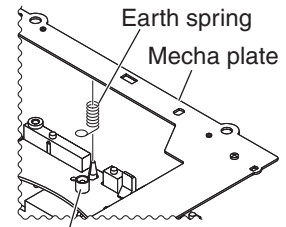

This boss is not installation position.

[2] Slotin Mechanism Section

- (1) Disconnect the one connector.
- (2) Unhook the four hooks.
- (3) Release the jumper wires, as required.
- (4) Remove the slotin mechanism section.

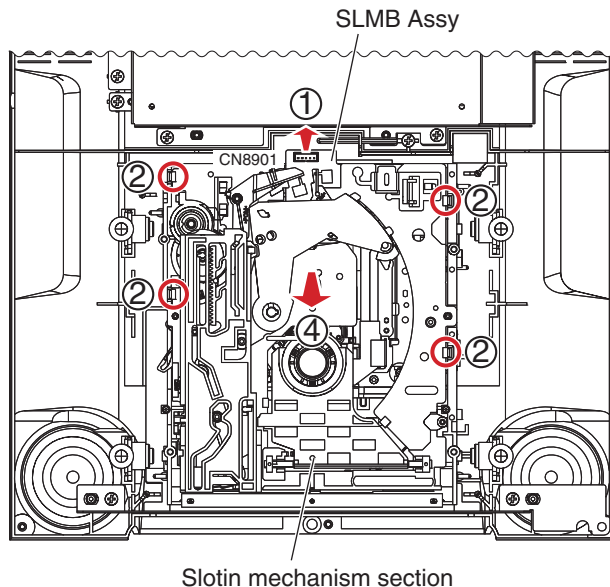

TM Assy-03S

[1] Float Base Section

(1) Short-circuit two positions of C and D soldering. (short)

Note:

After working, connect the flexible cable, then remove the soldered joint (open).

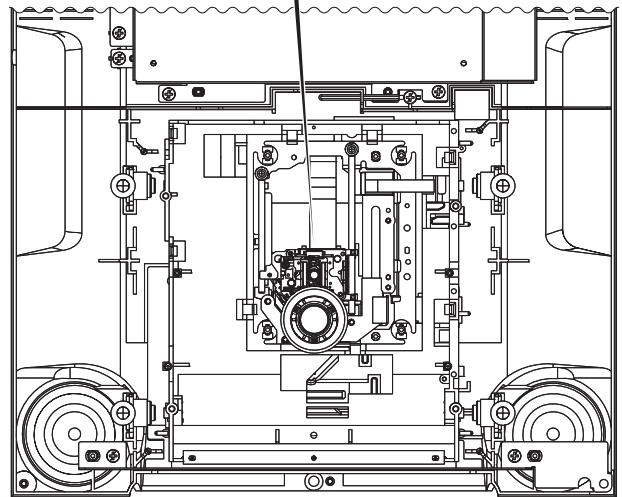
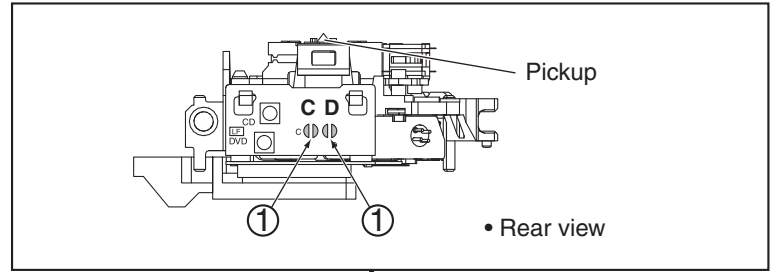

(2) Disconnect the three flexible cables.

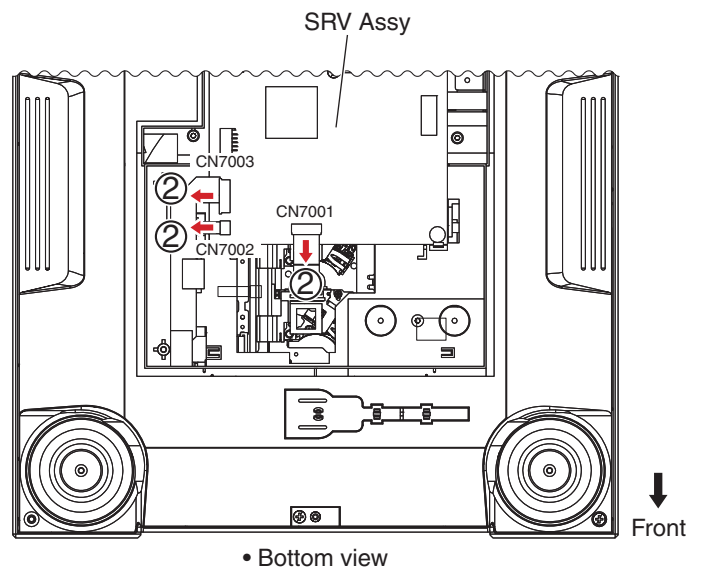

A
 (3) Remove the four DM screws. (DBA1260)

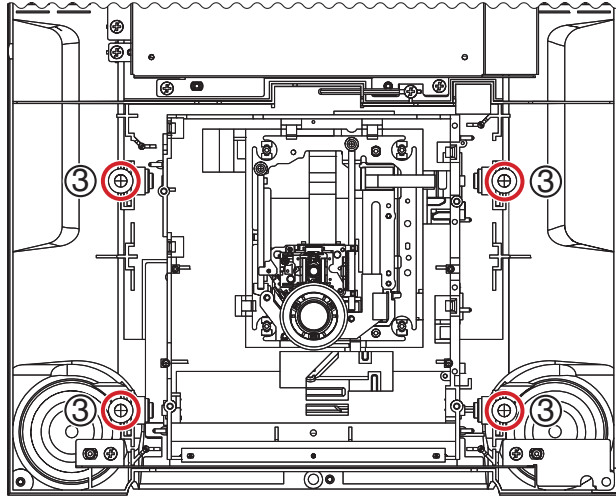

C
 (4) Remove the four float springs (G5).
 (5) Hook the four float springs (G5) to the four hooks of the float base 04 Assy.

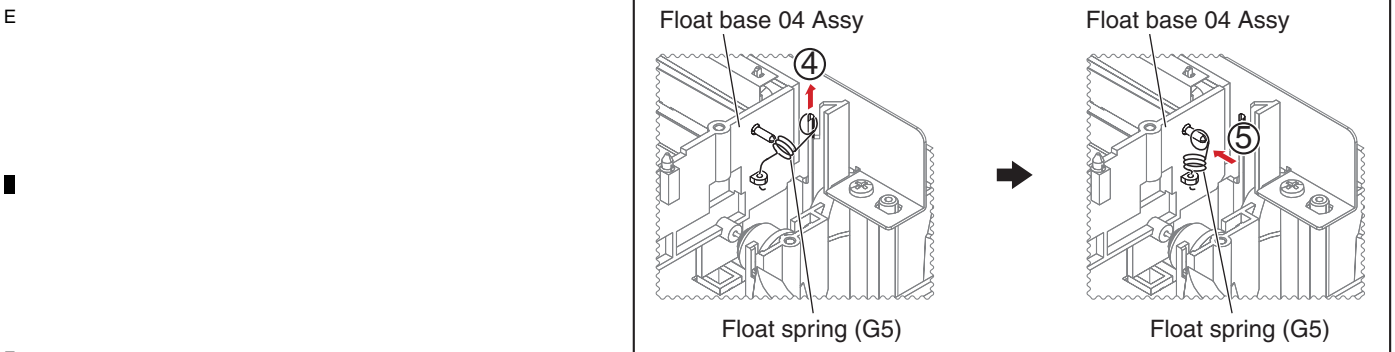
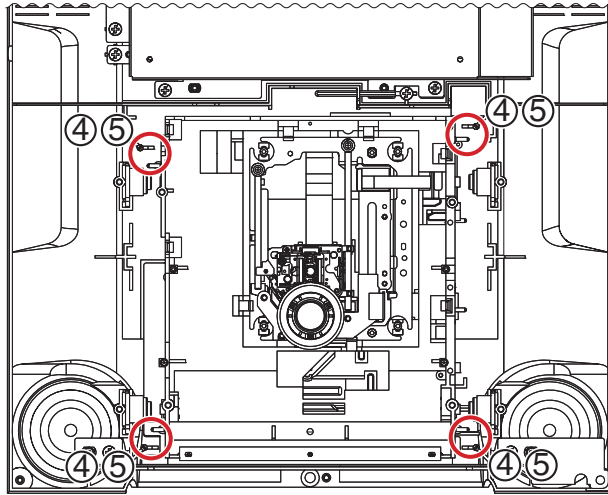

(6) Remove the float base section.

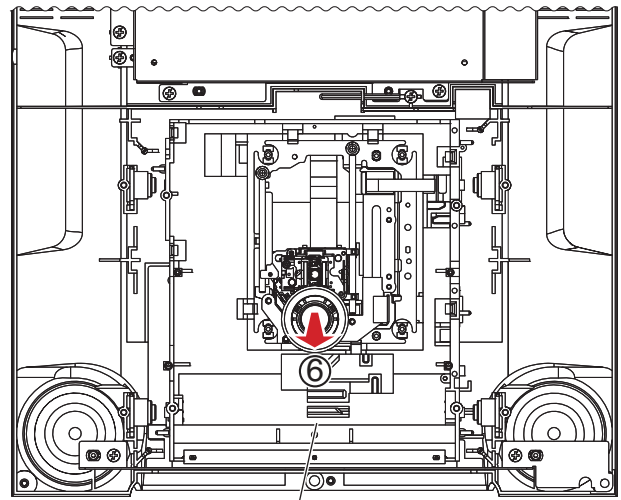

Float base section

Direction of the dampers when attaching them

When attaching the dampers, place them so that their projections (large) face front.

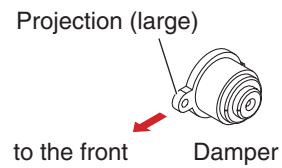

[2] TM Assy-03S

- (1) Unhook the four hooks.
- (2) Release the flexible cables, as required.
- (3) Remove the TM Assy-03S.

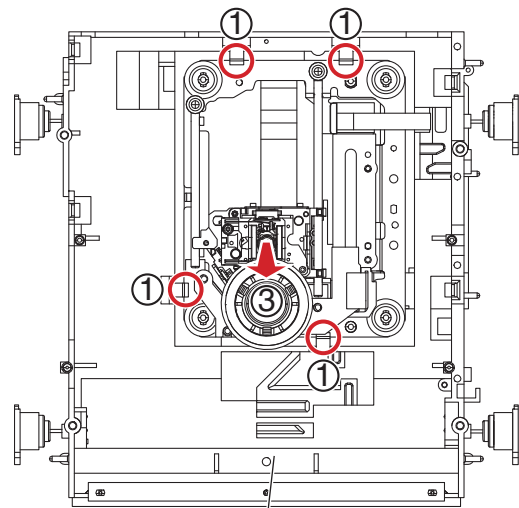

TM Assy-03S

Note on the float rubber installation

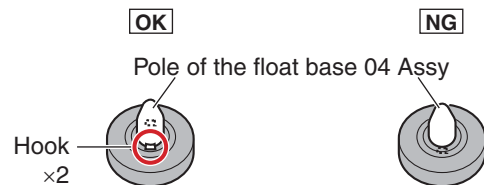

A Cleaning the pickup lens



Before shipment, be sure to clean the pickup lens, using the following cleaning materials:

- Cleaning liquid : GEM1004
- Cleaning paper: GED-008

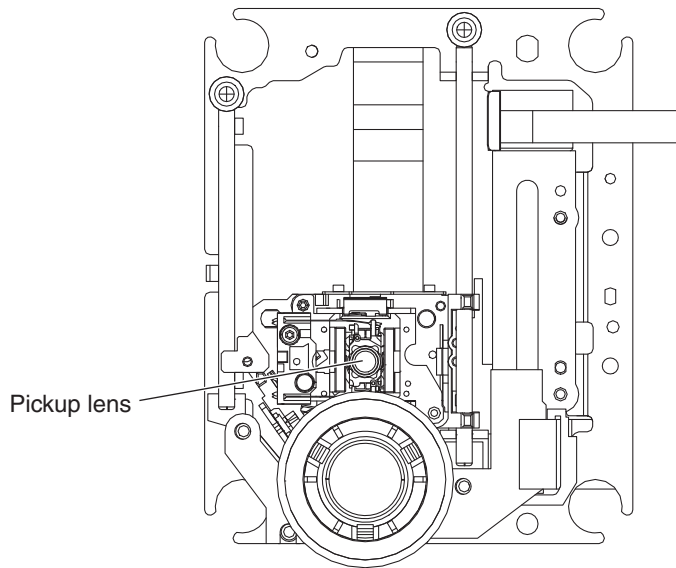

B

C

Arrangement of the flexible cable for pickup

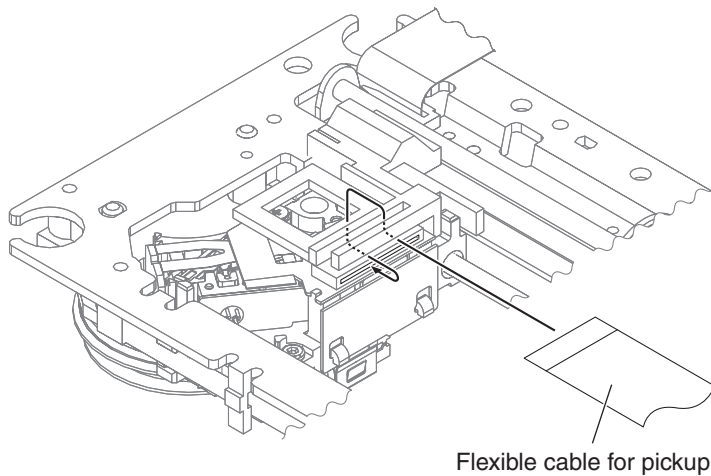

• Bottom view

D

E

F

JOG Dial Section

- (1) Disconnect the flexible cable.
- (2) Release the cord clamper.
- (3) Remove the six screws. (BPZ30P080FNI)
- (4) Remove it while pulling JOG dial section in front side.

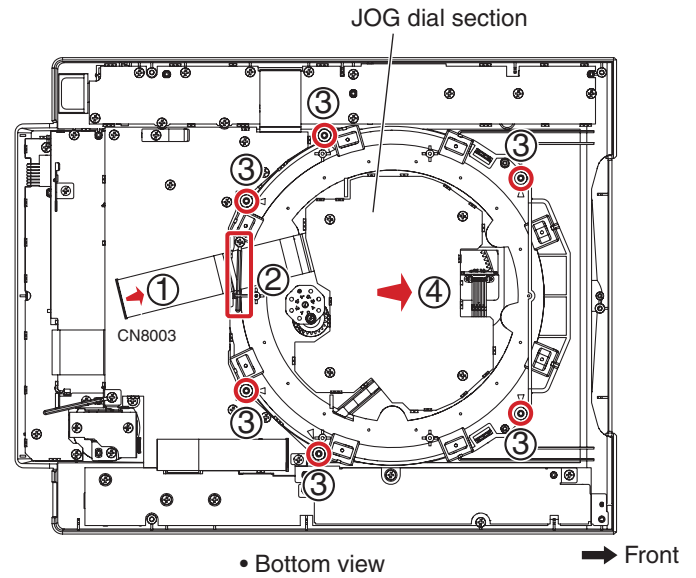

Position of the Adjust plate

About details of Adjustment etc., refer to the "8.1 JOG DIAL ROTATION LOAD ADJUSTMENT".

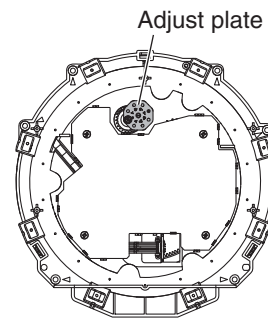

Screw tightening order

The other screws are random order.

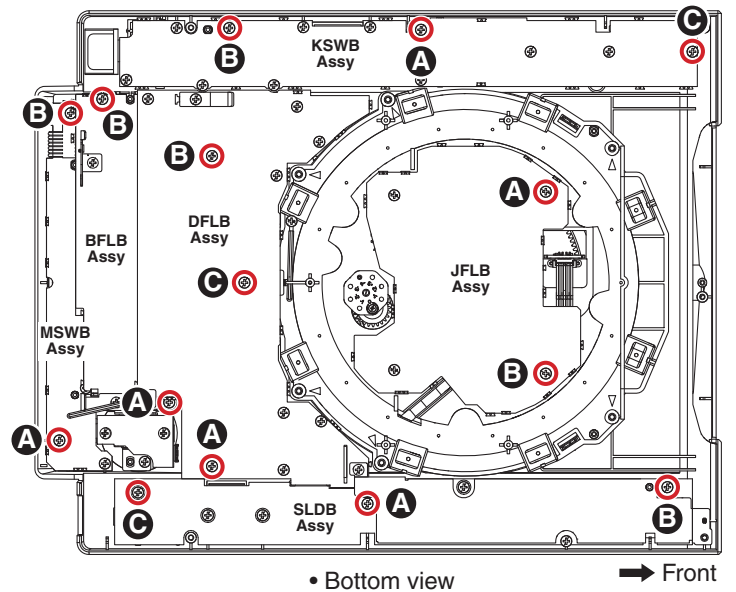

A

- (5) Unhook the three hooks.
- (6) Remove the JOG section.

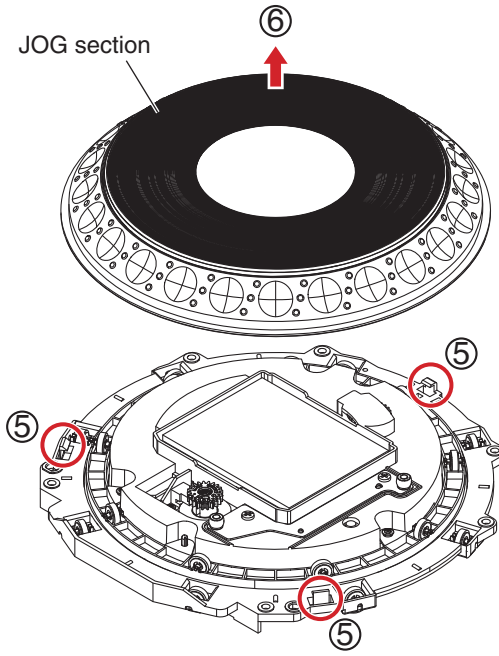

B

C



D

- (7) Remove the three screws. (DBA1265)
- (8) Remove the SW ring.

Note:
Be careful not to lost SW spring.

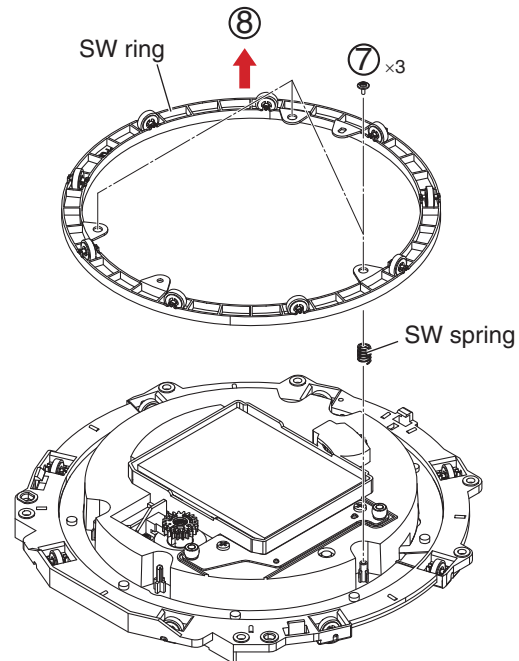

E

F

Notes on replacing the Sheet SW

Styling of the Sheet SW

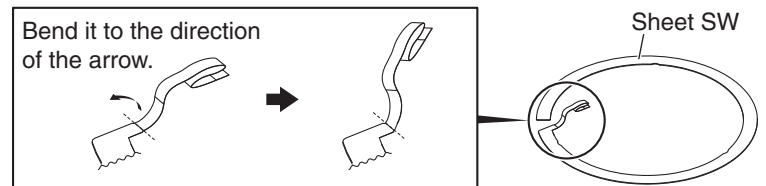

Notes on replacing the Sheet SW

Pasting position of the Sheet SW

Notes:

1. Be careful not to warp the sheet SW.
2. Remove any dirt on the JOG holder M to which the sheet SW is to be adhered. If some adhesive for the old sheet SW remains on the JOG holder M, completely remove it with a cloth moistened with alcohol.
3. Do NOT place the sheet SW so that it is mounted on the rib of JOG holder.
4. When adhering the sheet SW, be careful not to trap air bubbles in it. If air bubbles are formed, remove the sheet SW and adhere a new sheet SW. Do NOT reuse the removed sheet SW.
5. When making a connection, be sure to first release the lock of the connector then securely relock the connector after making the connection.

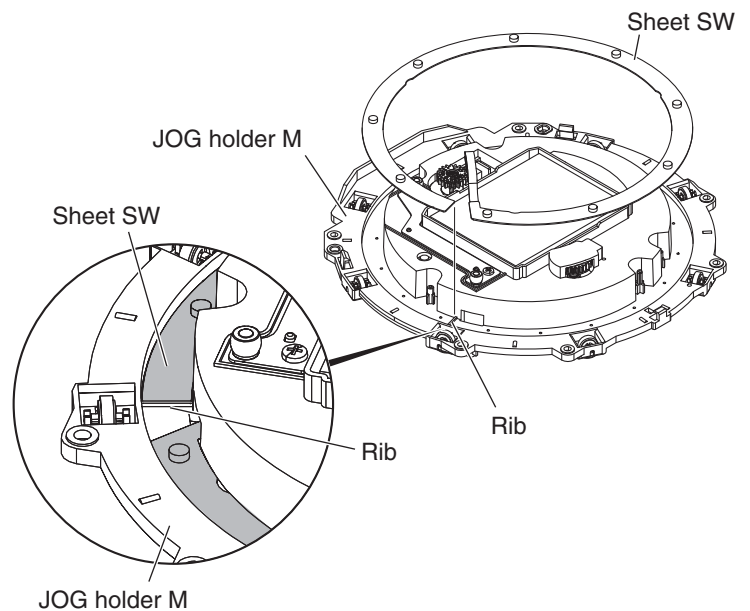

Pasting position of the SW cushion HH48/2

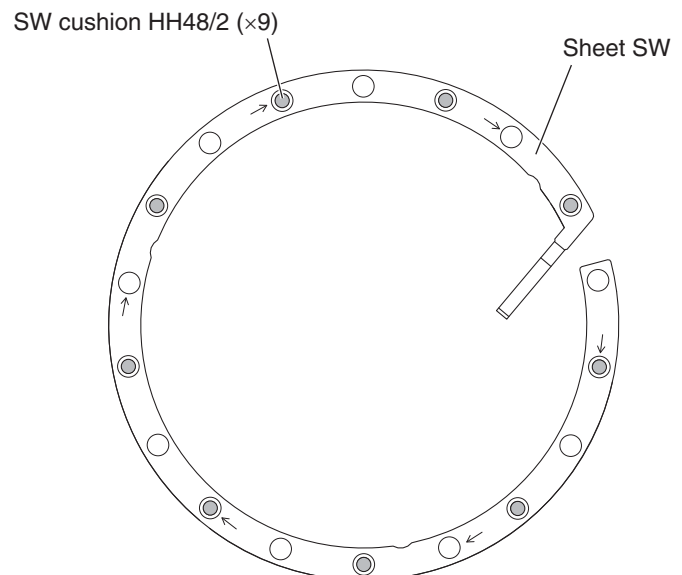

8. EACH SETTING AND ADJUSTMENT

8.1 JOG DIAL ROTATION LOAD ADJUSTMENT

JOG Check Mode : ON

• It is the mode which judges the load (light/-- heavy) numerically when rotating the JOG dial.

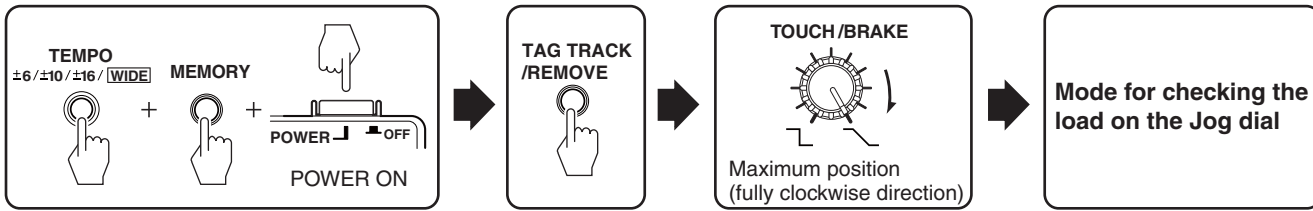

JOG Check Mode : CANCEL

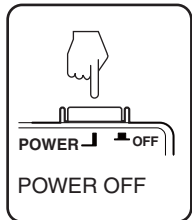

[Measuring method]

- The adjustment value of adjust plate is adjusted to "0" (Refer to Fig. 2).
- Enters the mode for checking the load on the Jog dial.
- The jog dial is mightly rotated. Moreover, the direction of the rotation is clockwise.
- The rotation speed and time are displayed in BROWSE FL (Refer to Fig. 1).
The time required so that the rotation may decrease from 3 X speed to 1.5 X speed when maximum speed is only 7 X speed or more is displayed.
The average of the rotation decrease time of 5 times in all is confirmed in spec or less.
Spec: 170 ± 20 msec.
- When the rotation decrease time is coming off from spec, the adjustment value of adjust plate is changed, and it does from 2 of above-mentioned to 4.

BROWSE_FL			
SERVICE MODE	JOG LOAD		OK
SPEED	TIME	SPEED	TIME
1.	8.96	150	4. — — —
2.	9.57	153	5. — — —
3.	— —	— —	AVR. 9.26 151

DATA_FL			
00	00:00:00	2	

Fig. 1 Example of displaying FL

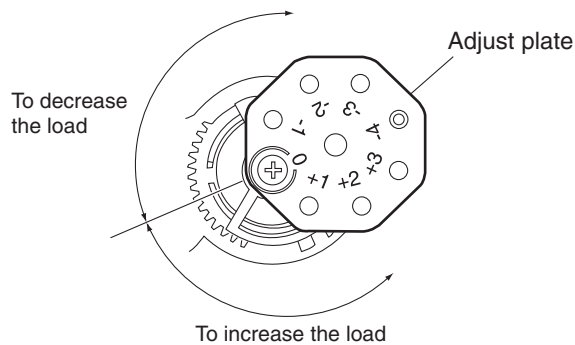

Fig. 2 Adjust plate

[Load adjustment method]

Remove the screw fixing the adjust plate, then screw it into the hole corresponding to the value (-1, -2, -3, -4, +1, +2 or +3) for a load to be added:

- 1, -2, -3, -4 : To decrease the load
- +1, +2, +3 : To increase the load

8.2 ITEMS FOR WHICH USER'S SETTING IS AVAILABLE

The following data have been set in each IC.

Item for Which User's Setting is Available	Setting Value (The factory default settings are indicated in bold.)	Part No.	Part Name	Ref No.	Assy	Content to be Stored
QUANTIZE	ON/OFF	DYW1775	Flash ROM	IC114	MAIN	UTILITY setting
SLIP FLASHING	ON/OFF					
PLAYER NO	AUTO , 1–4					
AUTO CUE LEVEL	-36dB/-42dB/-48dB/ -54dB/- 60dB -66dB/ -72dB/-78dB					
AUTO STANDBY	ON/OFF					
LIBRARY CREATOR	LIBRARY /FOLDER					
HISTORY NAME	–					
DIGITAL OUT	16 bit/ 24 bit					
MIDI CHANNEL	1 –16					
TIME MODE	TIME/ REMAIN					
AUTO CUE	ON/OFF	DYW1775	Flash ROM	IC114	MAIN	Statuses of keys
JOG MODE	CDJ /VINYL					

8.3 UPDATING OF THE FIRMWARE AND RECOVERY

For details on updating of firmware and recovery of the main unit, see [7] UPDATING OF FIRMWARE in “6.3 DETAILS ON SERVICE MODE.”

9. EXPLODED VIEWS AND PARTS LIST

NOTES: ● Parts marked by "NSP" are generally unavailable because they are not in our Master Spare Parts List.

- The \triangle mark found on some component parts indicates the importance of the safety factor of the part. Therefore, when replacing, be sure to use parts of identical designation.
- Screws adjacent to ∇ mark on product are used for disassembly.
- For the applying amount of lubricants or glue, follow the instructions in this manual. (In the case of no amount instructions, apply as you think it appropriate.)

9.1 PACKING SECTION

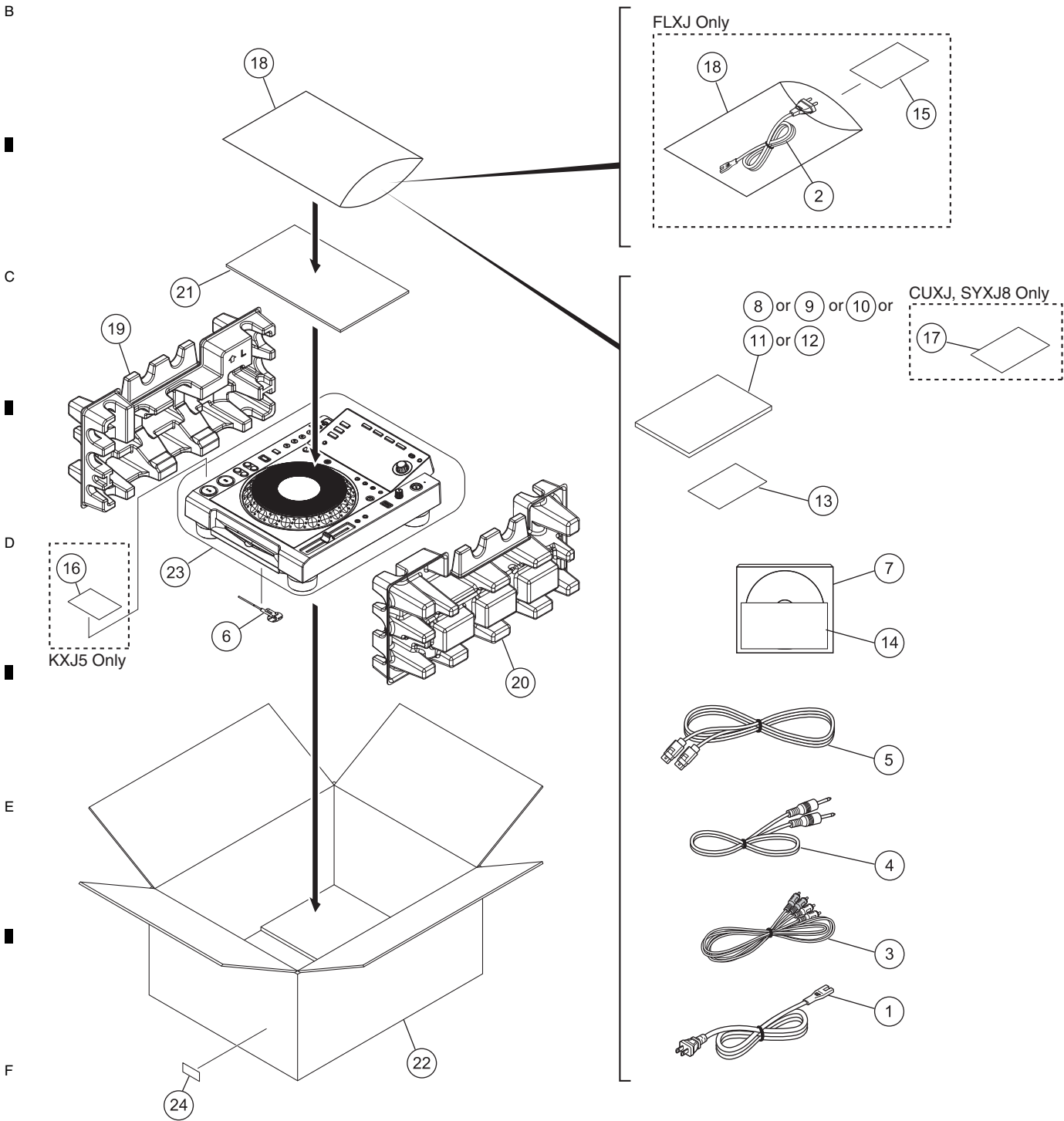

(1) PACKING SECTION PARTS LIST

<u>Mark No.</u>	<u>Description</u>	<u>Part No.</u>	<u>Mark No.</u>	<u>Description</u>	<u>Part No.</u>
⚠	1 Power Cable	See Contrast table (2)	16	Recycle Label M	See Contrast table (2)
⚠	2 Power Cable	See Contrast table (2)	NSP	17 Warranty Card	See Contrast table (2)
	3 Audio Cable (L = 1.5 m)	XDE3045	NSP	18 Polyethylene Bag (0.06 x 230 x 340)	AHG7117
	4 Control Cord (L = 1 m)	XDE3063		19 Pad L	DHA1792
	5 LAN Cable (1M UTP)	DDE1130		20 Pad R	DHA1793
	6 Disc Force Eject Pin	DEX1008		21 Accessory Pad	DHA1803
	7 CD-ROM (rekord box)	DXX2598		22 Packing Case	See Contrast table (2)
	8 Operating Instructions	See Contrast table (2)		23 Packing Sheet	RHC1023
	9 Operating Instructions	See Contrast table (2)		24 Serial Label	VRW1629
	10 Operating Instructions	See Contrast table (2)			
	11 Operating Instructions	See Contrast table (2)			
	12 Operating Instructions	See Contrast table (2)			
	13 Information Sheet	DRM1338			
NSP	14 License Key Label	DXA2190			
	15 Caution Card SB	See Contrast table (2)			

(2) CONTRAST TABLE

CDJ-900/CUXJ, SYXJ8, FLXJ, KXJ5 and AXJ5 are constructed the same except for the following:

Mark	No.	Symbol and Description	CDJ-900 /CUXJ	CDJ-900 /SYXJ8	CDJ-900 /FLXJ	CDJ-900 /KXJ5	CDJ-900 /AXJ5
⚠	1	Power Cable	ADG7021	ADG1154	ADG1154	XDG3054	ADG7079
⚠	2	Power Cable	Not used	Not used	ADG7097	Not used	Not used
	8	Operating Instructions (En, Fr)	DRB1486	Not used	Not used	Not used	Not used
	9	Operating Instructions (En, Fr, De, It, Ni, Es, Ru)	Not used	DRB1484	Not used	Not used	Not used
	10	Operating Instructions (En, Es, Zhtw)	Not used	Not used	DRB1487	Not used	Not used
	11	Operating Instructions (Ko)	Not used	Not used	Not used	DRB1489	Not used
	12	Operating Instructions (ZHcn, En)	Not used	Not used	Not used	Not used	DRB1488
	15	Caution Card SB	Not used	Not used	ARM7064	Not used	Not used
	16	Recycle Label M	Not used	Not used	Not used	DRW2307	Not used
NSP	17	Warranty Card	ARY7043	ARY7107	Not used	Not used	Not used
	22	Packing Case	DHG2806	DHG2805	DHG2807	DHG2810	DHG2808

(1) EXTERIOR SECTION PARTS LIST

<u>Mark No.</u>	<u>Description</u>	<u>Part No.</u>	<u>Mark No.</u>	<u>Description</u>	<u>Part No.</u>
	1 MAIN Assy	DWX3019	21	Bottom Packing	DEC3186
	2 SRV Assy	DWX3020	22	Front Plate	DNH2869
	3 JACB Assy	DWX3023	23	Shield Case	DNH2872
	4 ACIN Assy	See Contrast table (2)	24	Main PCB Stay	DNH2874
	5 USBA Assy	DWX3044	25	Heatsink	DNH2885
⚠	6 POWER SUPPLY Assy	DWR1463	26	Bottom Plate	See Contrast table (2)
	7 USB Cable	DDA1040	27	USB Holder	DNK5423
	8 40P FFC	DDD1500	28	Damper	CNV6011
	9 Connector Assy 6P	DKP3831	29	Earth Spring	DBH1398
	10 Connector Assy 12P	DKP3838	30	Float Spring (G5)	DBH1494
	11 Connector Assy 13P	DKP3849	31	Mecha Plate	DNH2642
NSP	12 Earth Lead Unit	DE007VF0	NSP 32	CCC S & E Label	See Contrast table (2)
	13 Power Knob	DAC2484	33	Cord Clamper (Steel)	RNH-184
	14 Lock Plate	DNH2905	34	•••••	
⚠	15 Chassis	See Contrast table (2)	35	•••••	
	16 USB Cover	DNK4999	36	DM Screw (FTC)	DBA1260
	17 Earth Plate	DBK1224	37	Screw	BBZ30P060FTB
	18 USB Earth Plate	DBK1351	38	Screw	BBZ30P060FTC
NSP	19 Silicon Rubber D5 L	DEB1456	39	Screw	BPZ30P080FNI
	20 Cushion	DEC3177	40	Screw	BPZ30P200FTB
			41	Screw	BPZ30P080FTB
			42	Screw	BSZ30P060FTC

(2) CONTRAST TABLE

CDJ-900/CUXJ, SYXJ8, FLXJ, KXJ5 and AXJ5 are constructed the same except for the following:

Mark	No.	Symbol and Description	CDJ-900 /CUXJ	CDJ-900 /SYXJ8	CDJ-900 /FLXJ	CDJ-900 /KXJ5	CDJ-900 /AXJ5
⚠	4	ACIN Assy	DWR1461	DWR1462	DWR1462	DWR1462	DWR1462
	15	Chassis	DNK5358	DNK5352	DNK5359	DNK5362	DNK5360
	26	Bottom Plate	DNH2895	DNH2871	DNH2896	DNH2899	DNH2897
NSP	32	CCC S & E Label	Not used	Not used	Not used	Not used	DRW2310

9.3 CONTROL PANEL SECTION

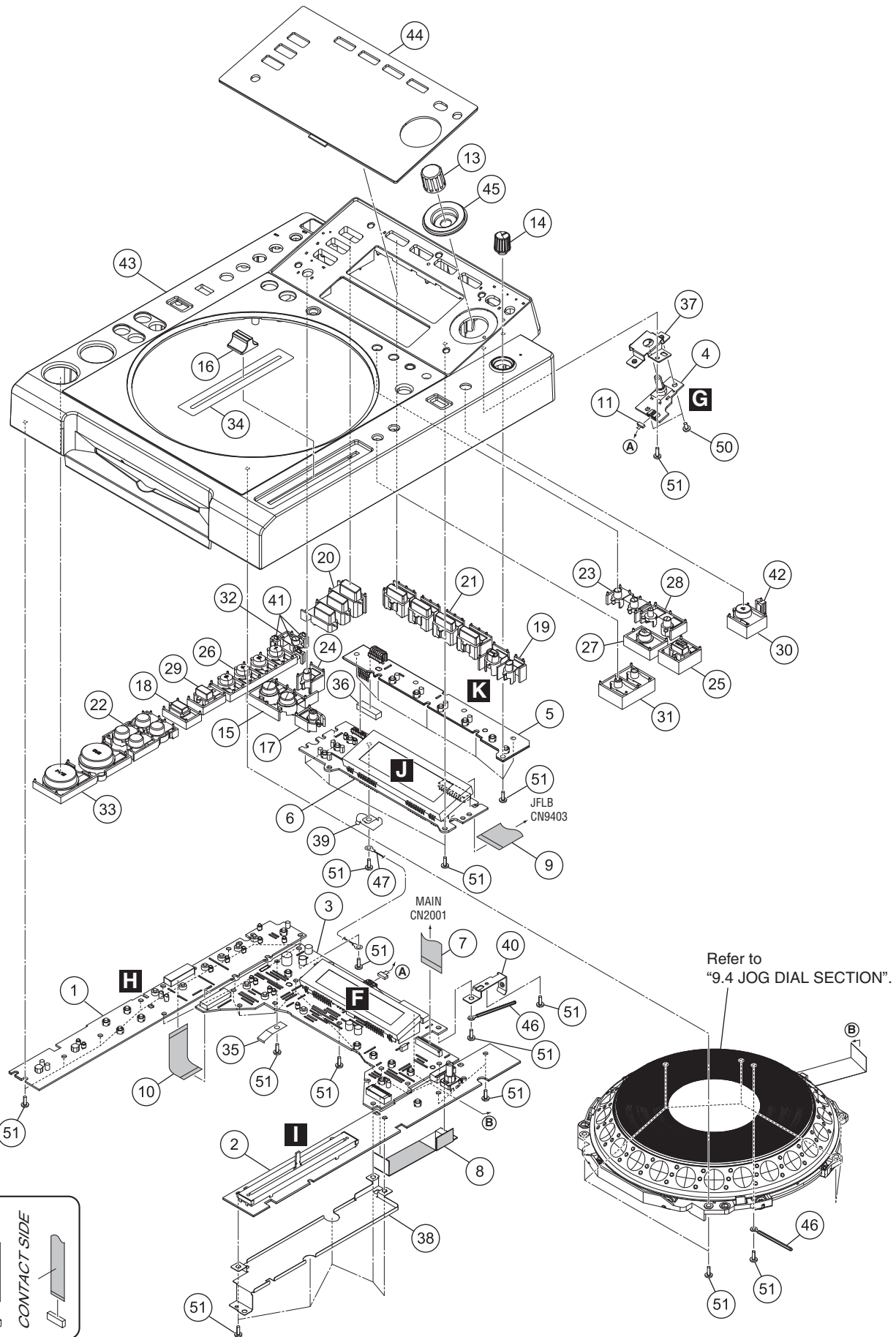

Refer to "9.4 JOG DIAL SECTION".

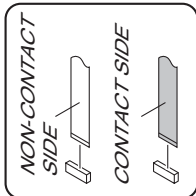

CONTROL PANEL SECTION PARTS LIST

<u>Mark No.</u>	<u>Description</u>	<u>Part No.</u>	<u>Mark No.</u>	<u>Description</u>	<u>Part No.</u>
1	KSWB Assy	DWS1416	46	Cord Clamper (Steel)	RNH-184
2	SLDB Assy	DWS1417	47	Earth Lead Unit	DDF1032
3	DFLB Assy	DWX3021	48	•••••	
4	ENCB Assy	DWX3022	49	•••••	
5	MSWB Assy	DWS1415	50	Screw	BBZ30P060FTC
6	BFLB Assy	DWX3025	51	Screw	BPZ30P080FNI
7	26P FFC	DDD1445			
8	13P FFC	DDD1449			
9	22P FFC	DDD1489			
10	20P FFC	DDD1501			
11	Connector Assy	PF04PP-Q17			
12	•••••				
13	Rotary Knob C	DAA1194			
14	Dial Knob	DAA1246			
15	Loop Knob	DAC2066			
16	Slide Knob	DAC2067			
17	Re-loop Knob	DAC2291			
18	Reverse Knob	DAC2364			
19	Menu Button	DAC2490			
20	Media Select Button	DAC2491			
21	Mode Select Button	DAC2492			
22	Set Button (SEARCH)	DAC2495			
23	Set Button (CALL)	DAC2497			
24	Time Button	DAC2498			
25	Vinyl Knob	DAC2542			
26	Auto Beat Roop Knob	DAC2543			
27	Quick Return Knob	DAC2544			
28	DEL MEMO Knob	DAC2545			
29	Beat Select Button	DAC2546			
30	Eject Button	DAC2548			
31	Tempo Button	DAC2549			
32	USB Stop Button	DAC2550			
33	Play Knob	DAC2596			
34	Slide Sheet 1C	DAH2404			
35	Earth Plate	DBK1224			
36	FFC Guard	DEC2586			
37	Encoder Stay	DNF1840			
38	Earth Plate	DNH2875			
39	Earth Plate S	DNH2906			
40	Earth Plate L	DNH2907			
41	USB Lens	DNK5353			
42	EUP Lens	DNK5408			
43	Control Panel	DNK5440			
44	Display Panel	DNK5442			
45	Encoder Ring	DNK5489			



9.4 JOG DIAL SECTION

1

2

3

4

A

B

C

D

E

F

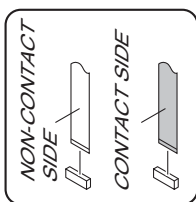
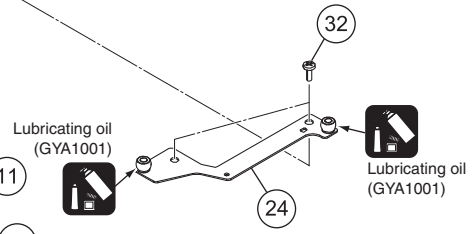
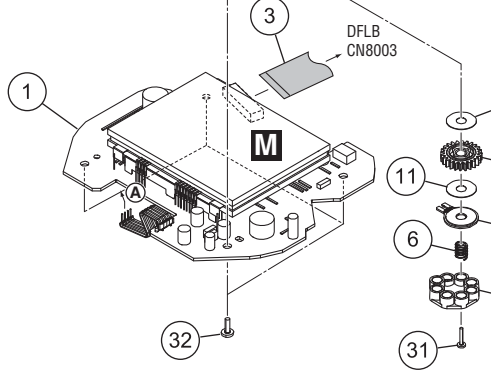
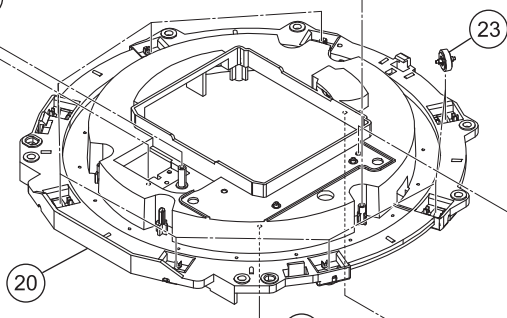
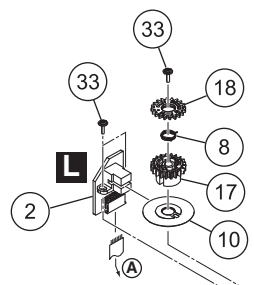
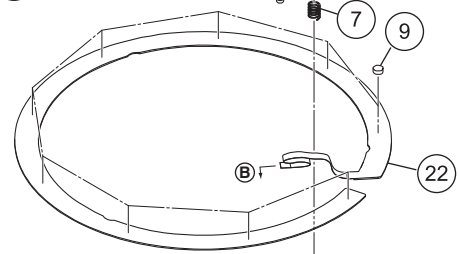
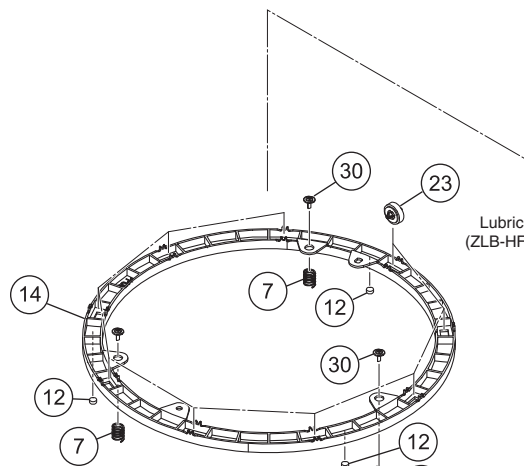
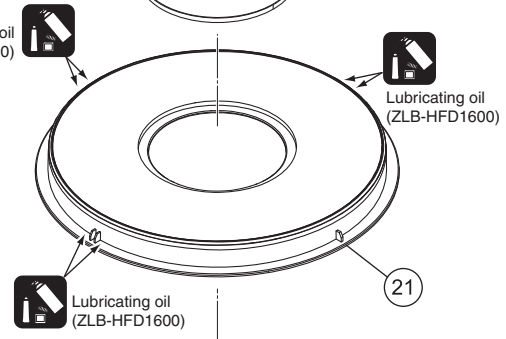
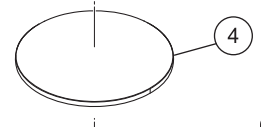
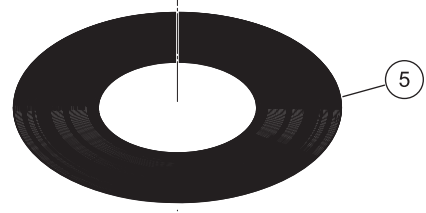
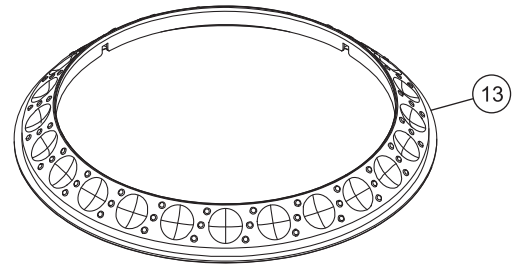

1

2

3

4

JOG DIAL SECTION PARTS LIST

<u>Mark No.</u>	<u>Description</u>	<u>Part No.</u>	
1	JFLB Assy	DWX3024	
2	JOGB Assy	DWX3026	A
3	19P FFC	DDD1490	
4	JOG Panel	DAH2609	
5	JOG Plate M	DAH2690	
6	Load Spring	DBH1680	
7	SW spring	DBH1681	
8	Encoder Spring	DBH1710	
9	SW Cushion HH48/2	DEC2538	
10	Encoder Plate	DEC2889	
11	Washer	DEC3137	B
12	Ring Cushion L24/2.0	DEC2958	
13	JOG B	DNK4068	
14	SW Ring	DNK5233	
15	Load Gear	DNK5236	
16	Smoother	DNK5237	
17	Gear A	DNK5241	
18	Gear B	DNK5242	
19	Adjust Plate	DNK5300	
20	JOG Holder M	DNK5356	C
21	JOG Dial A	DNK5357	
22	Sheet SW	DSX1078	
23	Roller A Assy	DXB2010	
24	JOG Stay Assy	DXB2015	
25	•••••		
26	•••••		
27	•••••		
28	•••••		
29	•••••		
30	Screw (FE)	DBA1265	D
31	Screw	BPZ20P100FTC	
32	Screw	BPZ30P080FNI	
33	Screw	IPZ20P060FTC	

9.5 SLOTIN MECHA SECTION

1 2 3 4

A
B
C
D
E
F

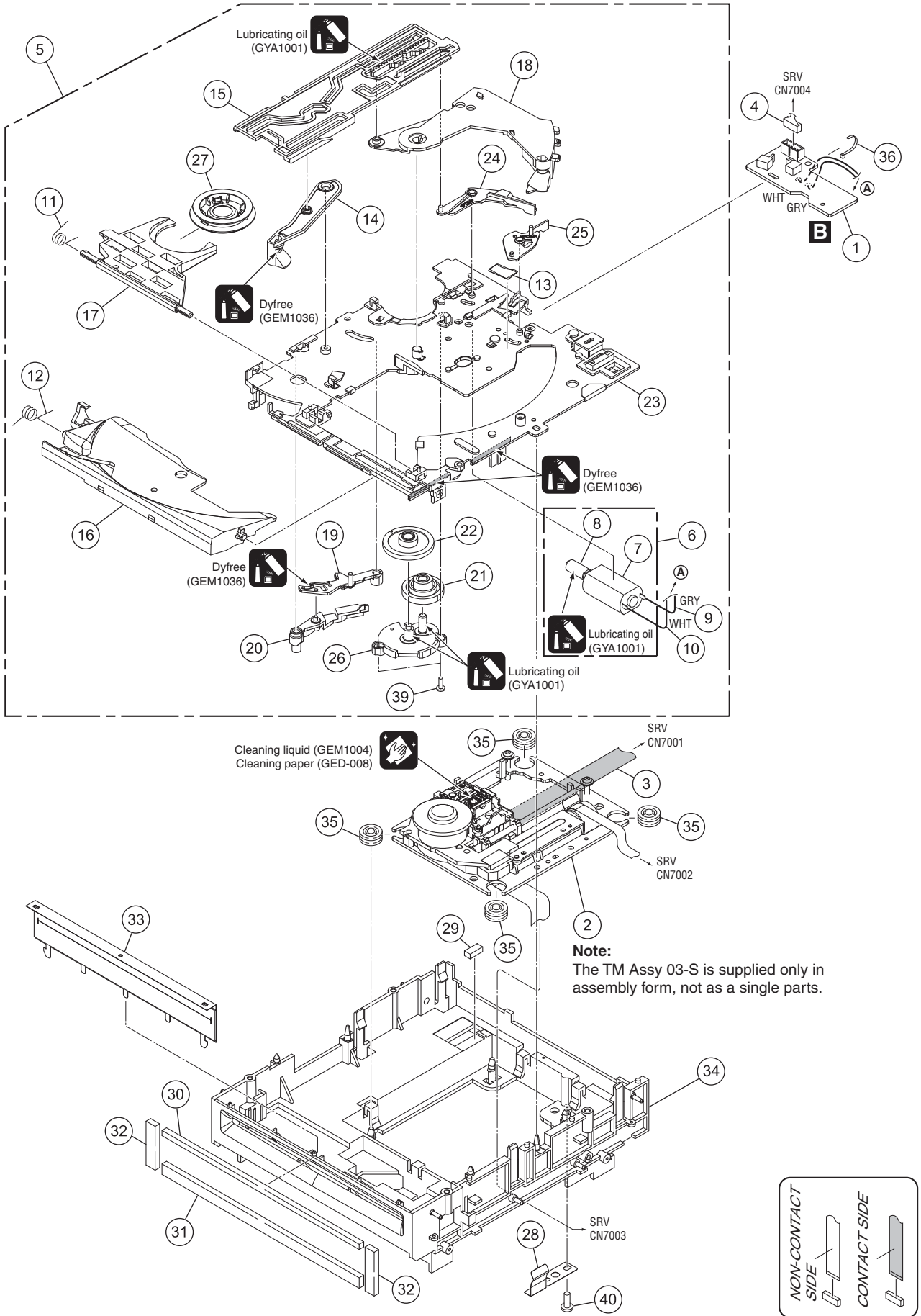

1 2 3 4

SLOTIN MECHA SECTION PARTS LIST

<u>Mark No.</u>	<u>Description</u>	<u>Part No.</u>	
	1 SLMB Assy	DWS1418	
	2 TM Assy 03-S	VXX3125	A
	3 24P FFC	DDD1450	
	4 Connector Assy	PF05PP-B17	
NSP	5 SLOTIN MECHA Assy	DXA2121	
	6 DC Motor Assy-S	DXX2510	
NSP	7 DC Motor S	DXM1230	
NSP	8 Worm Gear	DNK3910	
	9 Lead Wire	ZWNN1007G28-8-06A	
	10 Lead Wire	ZWNN1007G28-9-06A	
	11 Clamp Spring	DBH1374	B
	12 Guide Spring	DBH1375	
	13 SW. Lever Spacer SV	DEC2831	
	14 Loading Lever	DNK3406	
	15 Main Cam	DNK3407	
	16 Disc Guide	DNK3478	
	17 Clamp Arm	DNK3576	
	18 Eject Lever	DNK3684	
	19 Lever AP	DNK3835	
	20 Lever BP	DNK3836	C
	21 Loading Gear	DNK3911	
	22 Drive Gear	DNK3912	
	23 Loading Base SV	DNK4369	
	24 SW Lever SV1	DNK4370	
	25 SW Lever SV2	DNK4371	
	26 Gear Holder SV	DNK4372	
	27 Clamper 04 Assy	DXB1859	
	28 FPC Guard	DBK1282	
	29 Spacer POR (T3)	DEB1566	
	30 Vessel Cushion A	DEC2852	D
	31 Vessel Cushion B	DEC2853	
	32 Vessel Cushion C	DEC2854	
	33 Front Sheet	DED1132	
	34 Float Base 04 Assy	DXB1838	
	35 Floating Rubber	VEB1351	
	36 Binder (SKB090BK)	ZCA-SKB90BK	
	37 ●●●●●		
	38 ●●●●●		E
	39 Screw	BPZ20P060FTC	
	40 Screw	BPZ30P080FNI	

10. SCHEMATIC DIAGRAM

10.1 SRV ASSY (1/2)

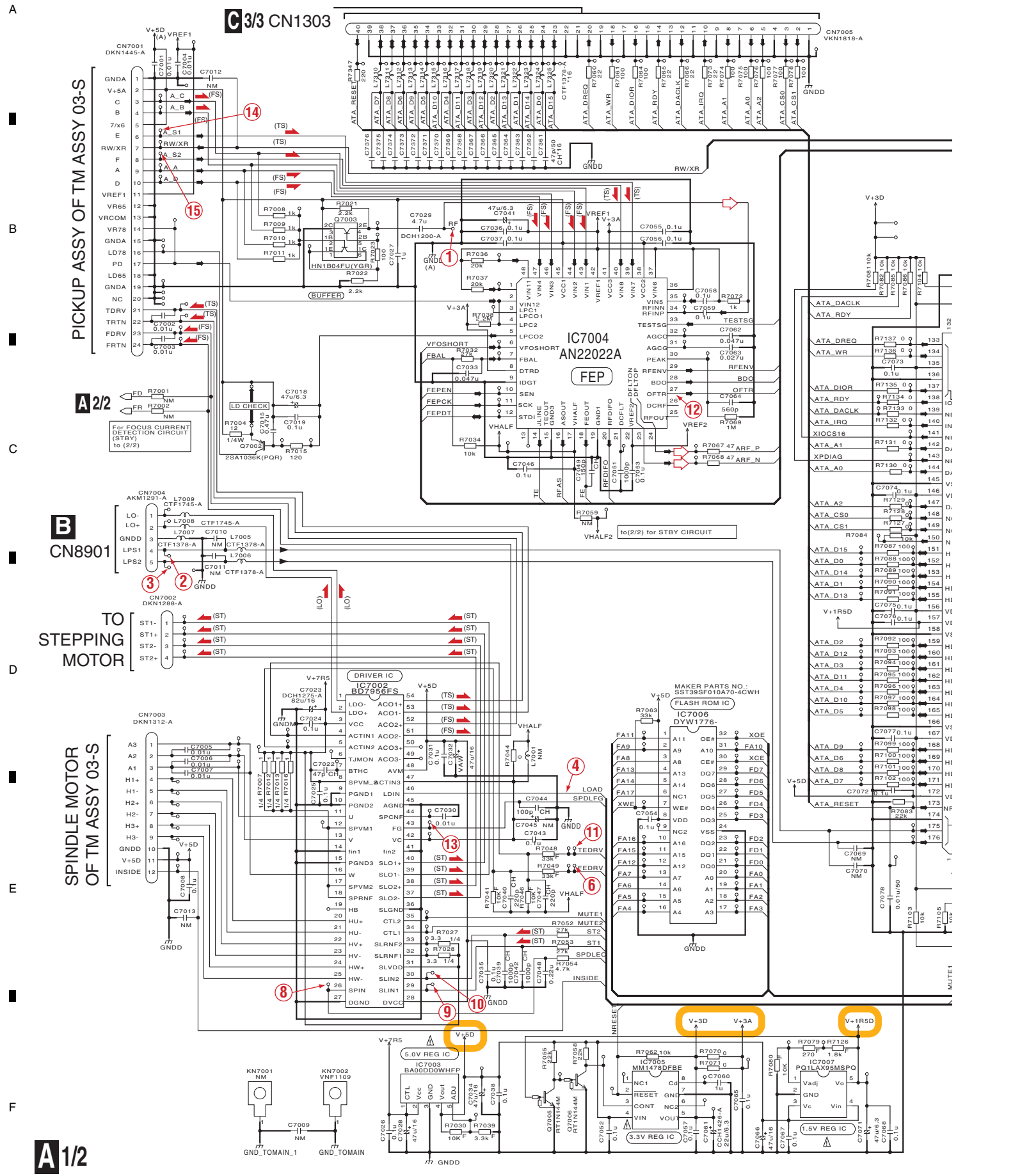



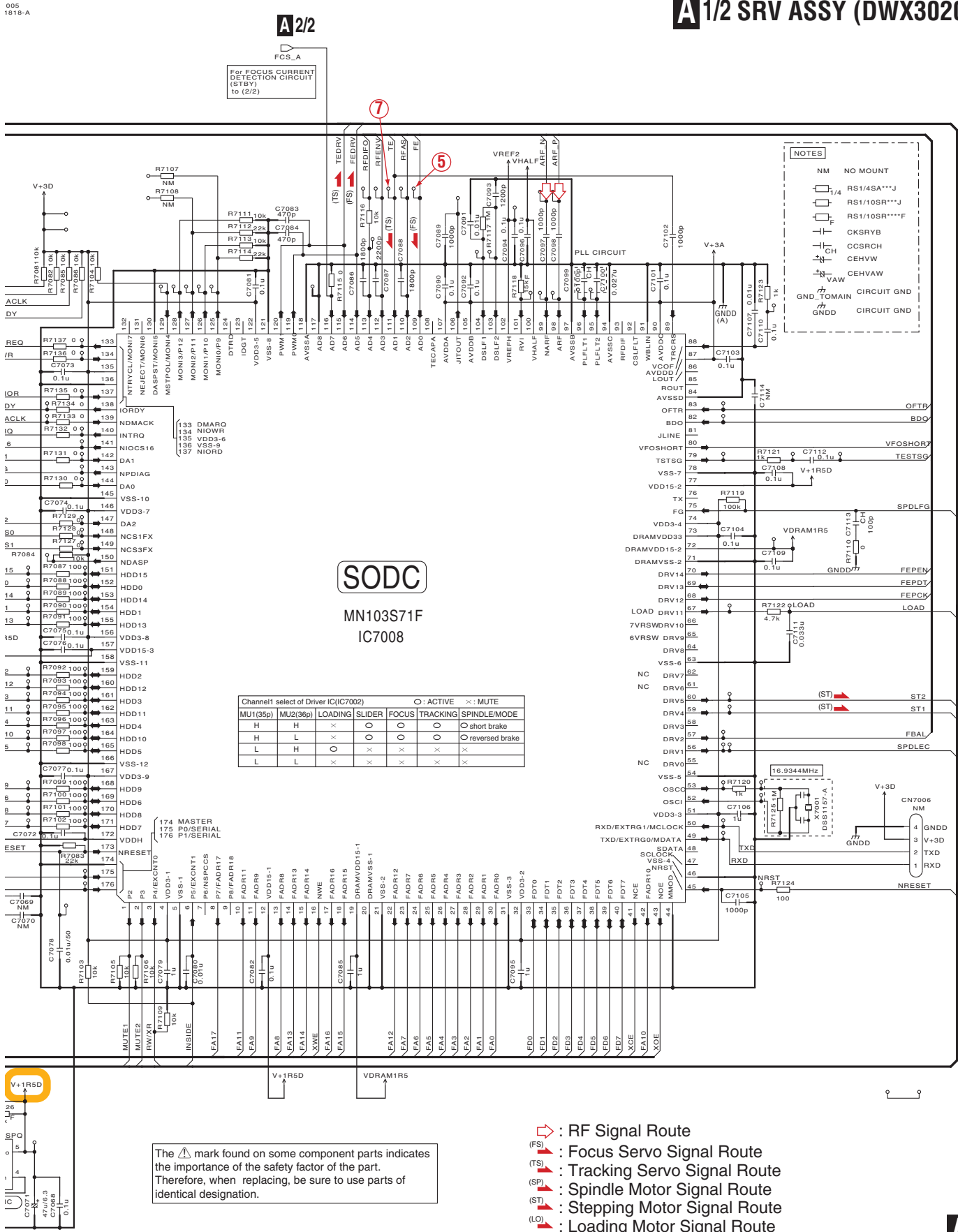





A 1/2 SRV ASSY (DWX3020)



CAUTION
 FOR CONTINUED PROTECTION
 AGAINST RISK OF FIRE.
 REPLACE ONLY WITH SAME TYPE No.
 0437.375
 MFD. BY LITTELFUSE INC. FOR P7302
 04371.25
 MFD. BY LITTELFUSE INC. FOR P7307,P7310

The  mark found on some component parts indicates the importance of the safety factor of the part. Therefore, when replacing, be sure to use parts of identical designation.

NOTES	
NM	NO MOUNT
	RS1/10SR***J
	RS1/10SR***D
	RST1/2SP***J
	CKSRB(1608) or CKSQYB(2125)
	CCSRCH
	CEHVW
	CIRCUIT GND
	CIRCUIT GND GND_TOMAIN

B SLMB ASSY (DWS1408)

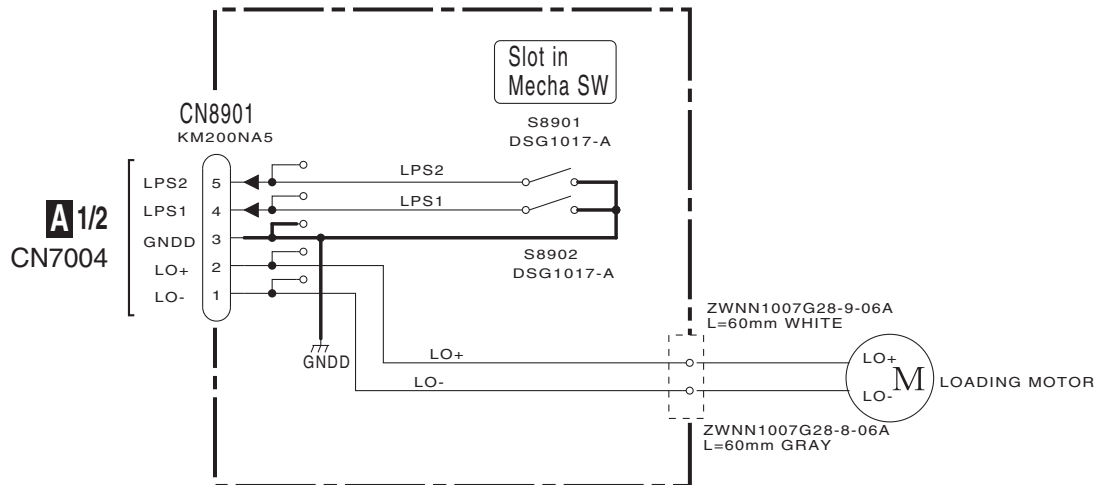

For FOCUS CURRENT DETECTION CIRCUIT (STBY)

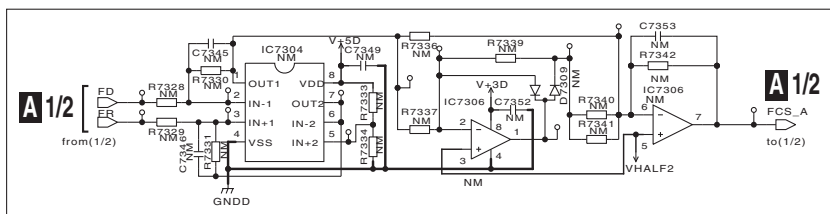

10.3 MAIN ASSY (1/3)

C-a 1/3

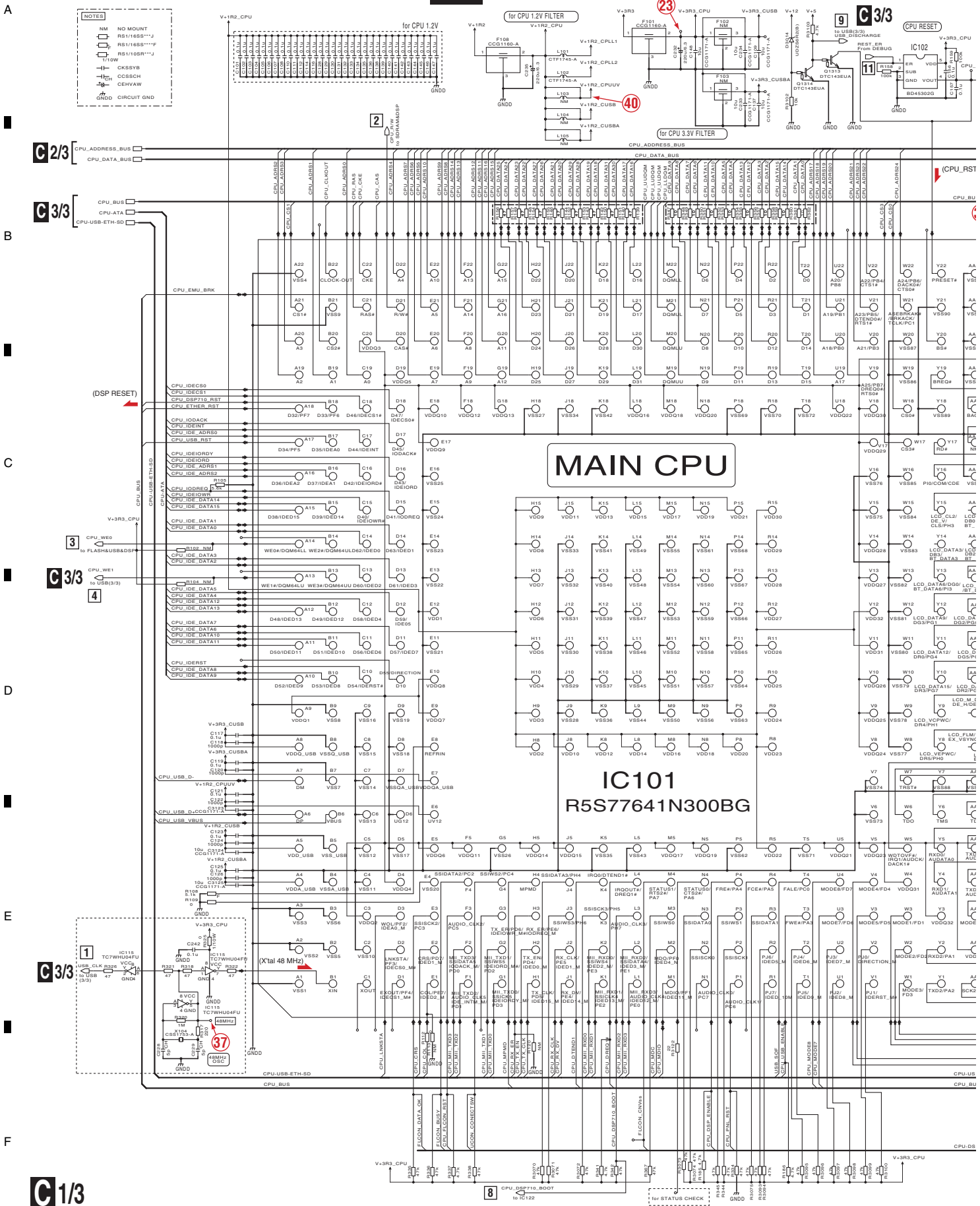

C-b 2/3

C 2/3 MAIN ASSY (DWX3019)

CAUTION
 FOR CONTINUED PROTECTION
 AGAINST RISK OF FIRE,
 REPLACE ONLY WITH SAME TYPE NO.
 0437-500
 MFD. BY LITTELFUSE INC. FOR P2

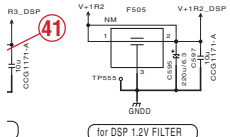

C 3/3

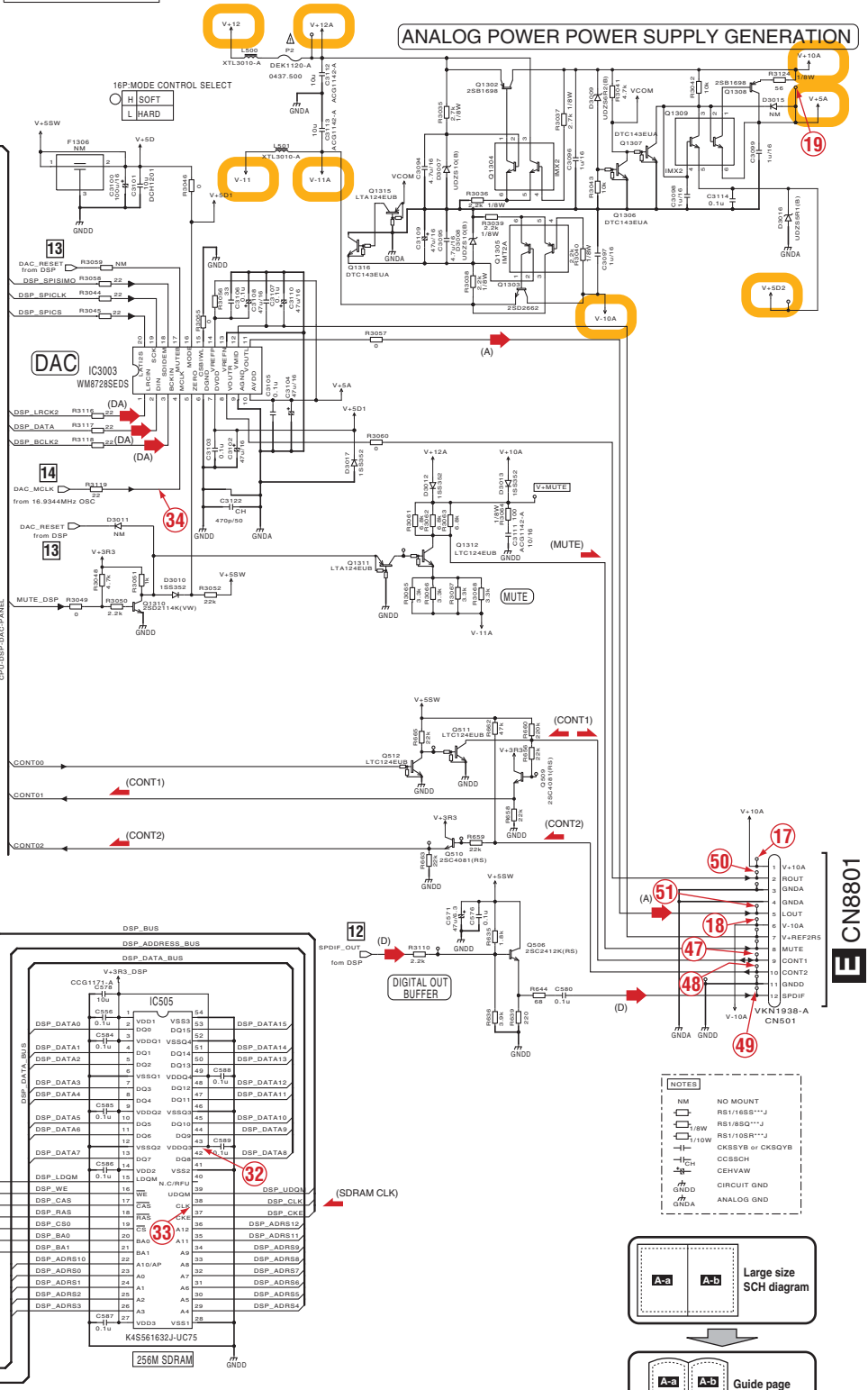
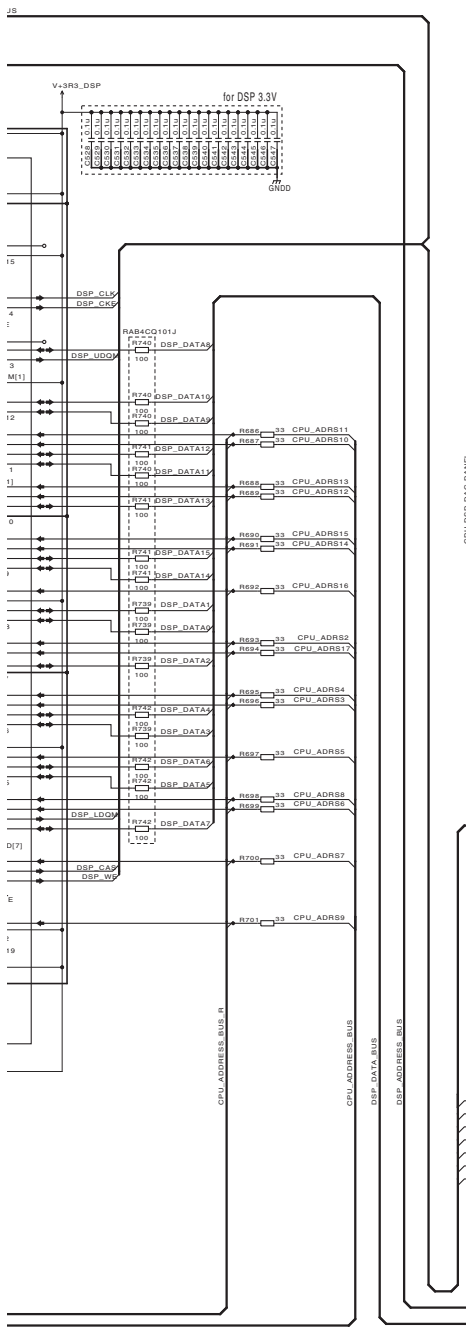

The **⚠** mark found on some component parts indicates the importance of the safety factor of the part. Therefore, when replacing, be sure to use parts of identical designation.

- (DA) : Audio Data Signal Route
- (A) : Analog Audio Signal Route
- (D) : Digital Data Signal Route

NOTES

- NM NO MOUNT
- RS1165S**J
- RS1882**J
- RS11026R**J
- CS85Y8 or CK50Y8
- CS85CH
- CEVAW
- CIRCUIT GND
- ANALOG GND

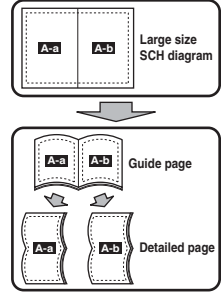

E CN8801



C-2/3 MAIN ASSY (DWX3019)

A-a A-b

CAUTION
 1. WAXES PROTECTION
 AGAINST RISK OF FIRE.
 2. REPLACE ONLY WITH SAME TYPE No.
 0437.500
 MFD. BY LITTELFUSE INC. FOR P2

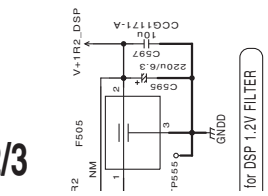
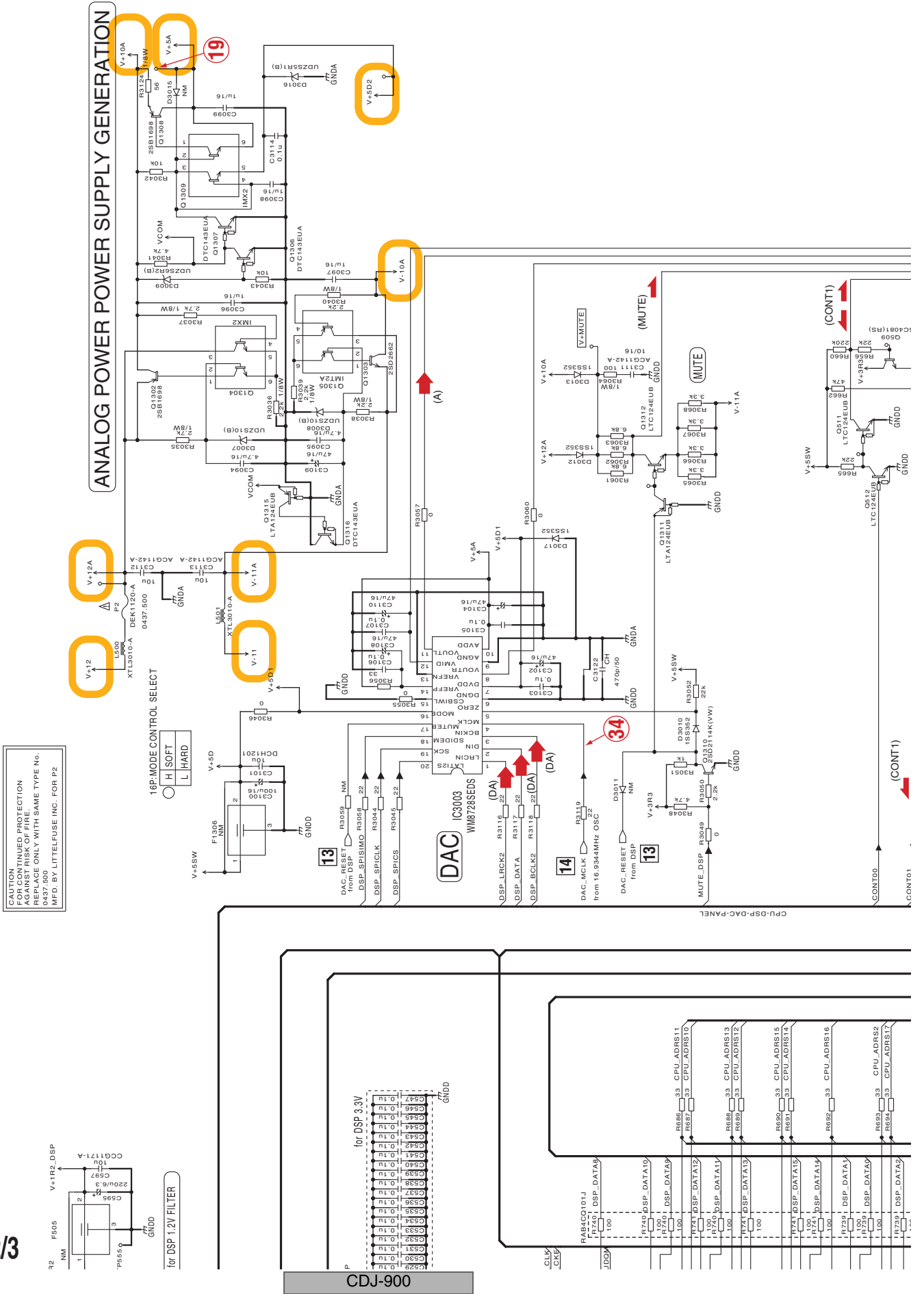

for DSP 1.2V FILTER

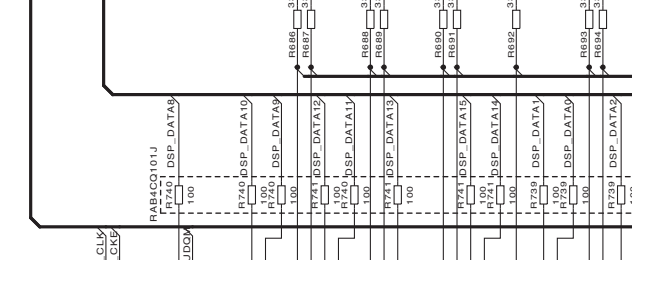
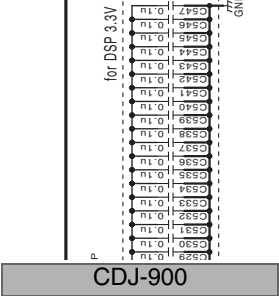

1 2 3 4 5 6 7 8 9 10 11 12 13 14 15 16 17 18 19 20 21 22 23 24 25 26 27 28 29 30 31 32

A B C D E F

C-b 2/3
 90

1088N0

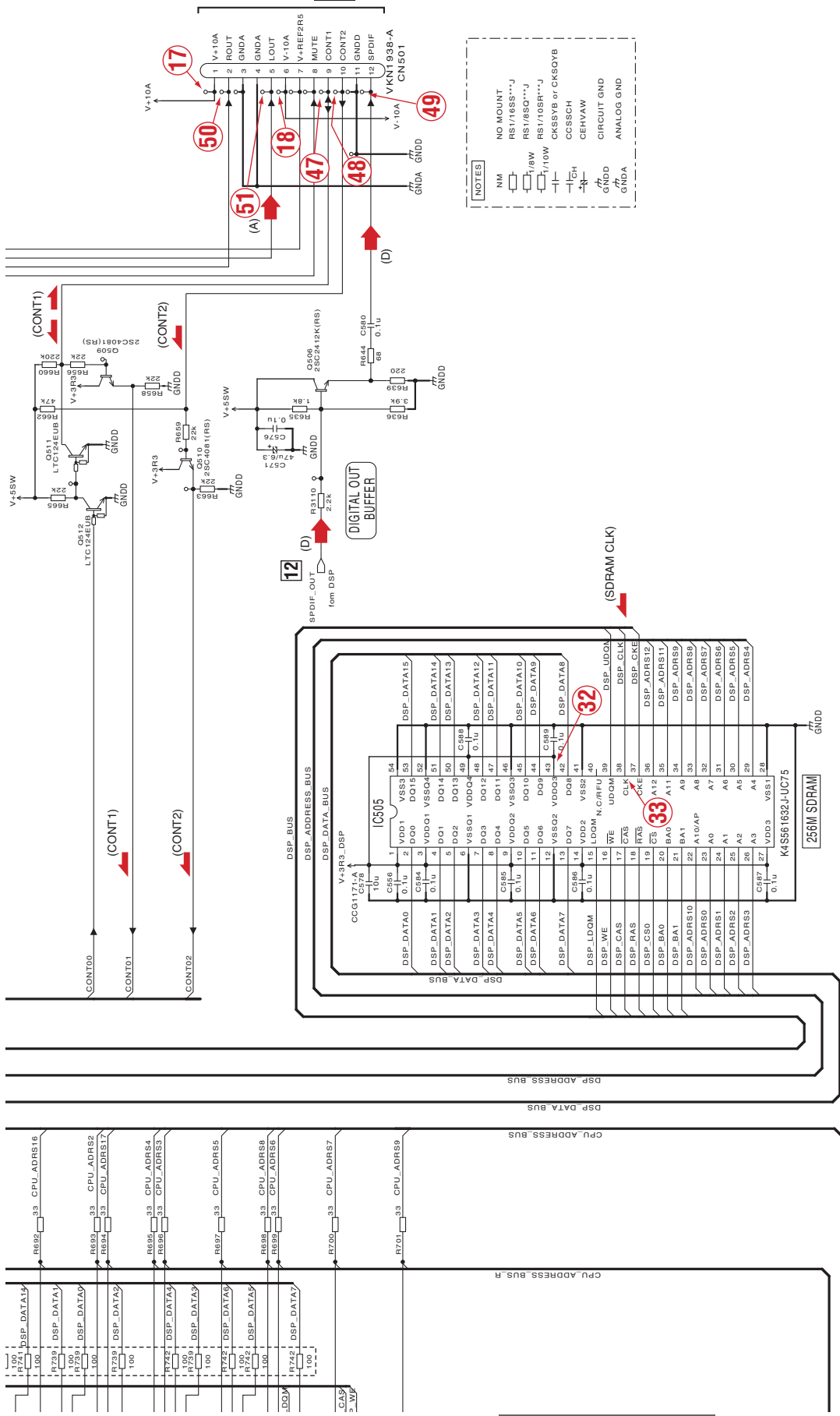

NOTES

- NM NO MOUNT
- RS1/16SS**J
- RS1/8SO**J
- RS1/10SR**J
- RS1/10W
- CKSSYB or CKSOYB
- CCSSCH
- CEH/VAV
- CIRCUIT GND
- ANALOG GND

- (DA) : Audio Data Signal Route
- (A) : Analog Audio Signal Route
- (D) : Digital Data Signal Route

The Δ mark found on some component parts indicates the importance of the safety factor of the part. Therefore, when replacing, be sure to use parts of identical designation.

A-a A-b

A B C D E F

CDJ-900

C/23 MAIN ASSY (DWX3019)

A-a-b

C-a 2/3

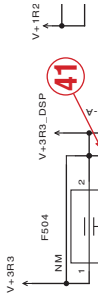
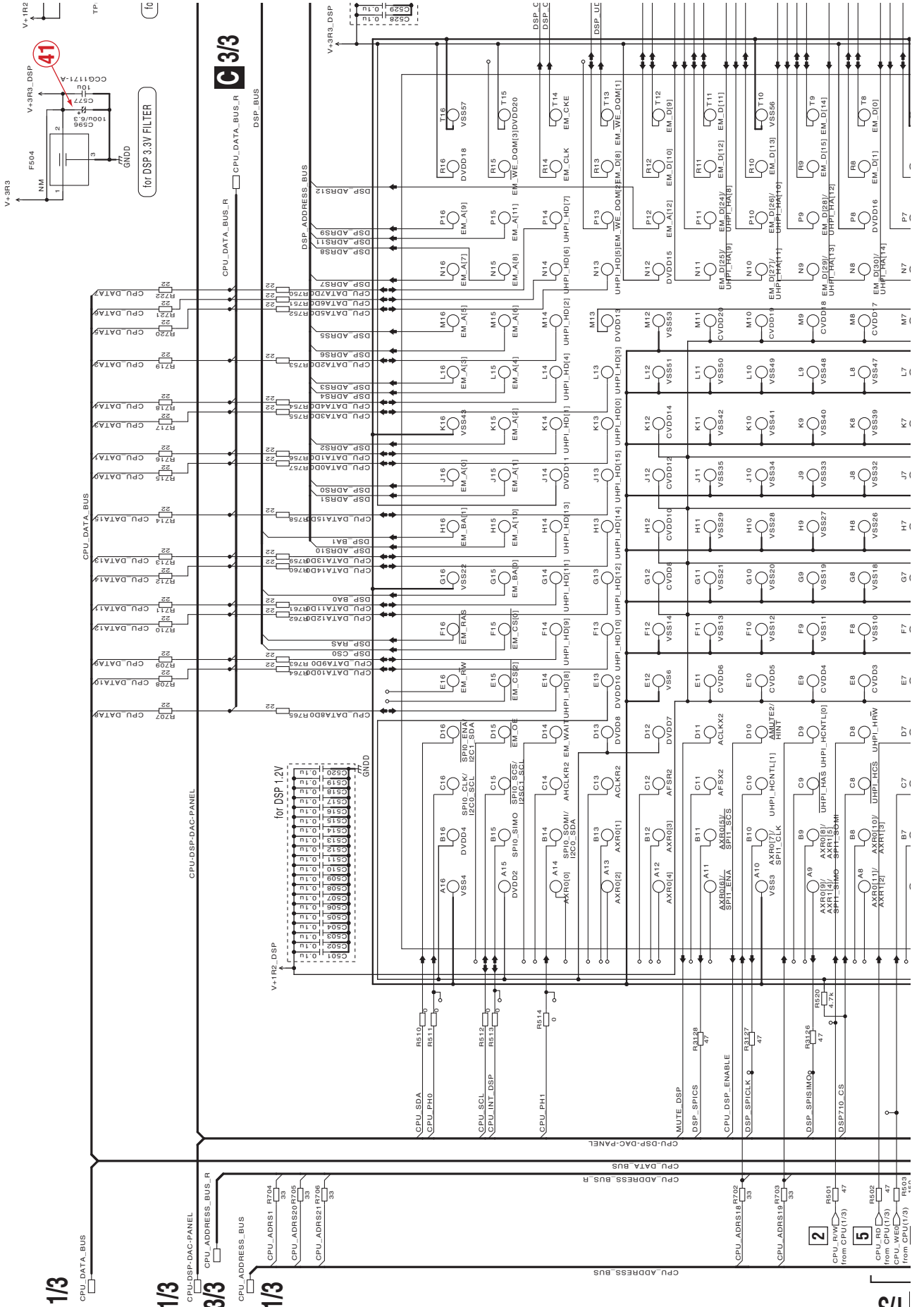

CDJ-900

1

2

3

4

1

2

3

4

1/3

10.6 JACB ASSY

1 2 3 4

When On p No. 4 In su This For p desc

- NOTES**
- NM NO MOUNT
 - RS1/10SR***J or RS1/8SQ***J
 - CKSRYB
 - GND F FRAME GND
 - GND C CIRCUIT GND
 - GND A CIRCUIT GND

AUDIO FILTER

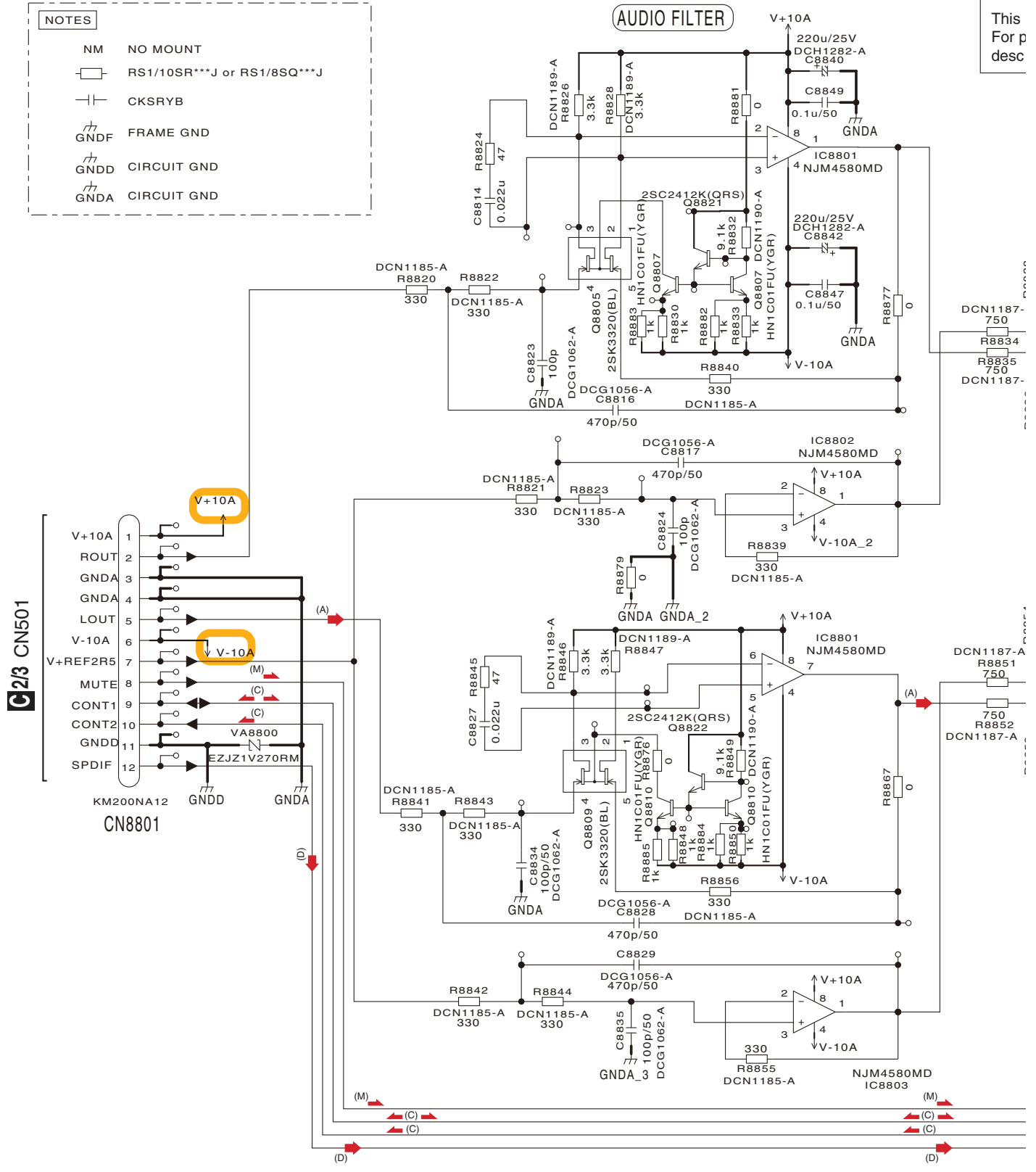

C2/3 CN501

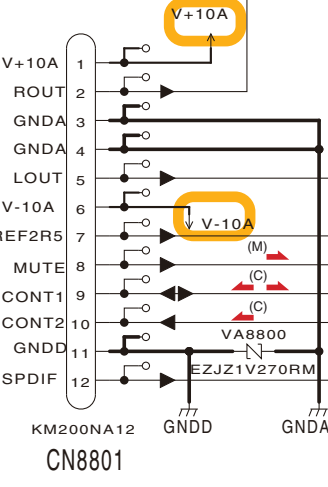

1 2 3 4

JACB ASSY (DWX3023)

When repairing the JACB ASSY, note the following:

On part of the initial-lot JACB ASSY, the DCN1186-A (470 ohms, Part description No. 471) is mounted as the resistors (R8820-8823, 8839-8844, 8855, and 8856). In such a case, mount a new DCN1186-A during replacement.

This applies only to the initial-lot products for the destinations SYXJ8 and FLXJ. For products for other destinations, replace with the DCN1185-A (330 ohms, Part description No. 331), as described in the circuit diagram.

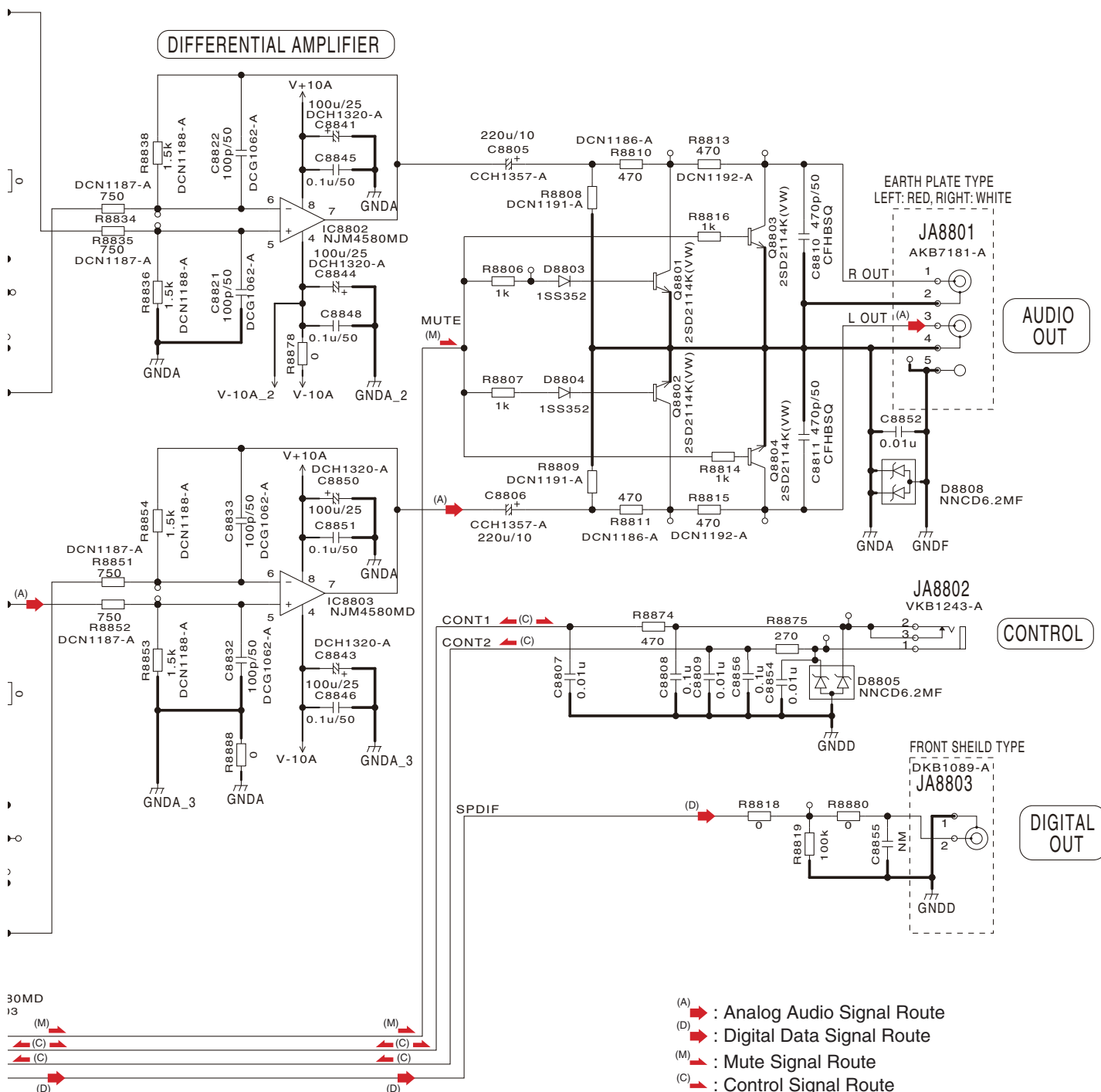

10.7 DFLB and ENCB ASSYS

F DFLB ASSY (DWX3021)

C 3/3 CN2001

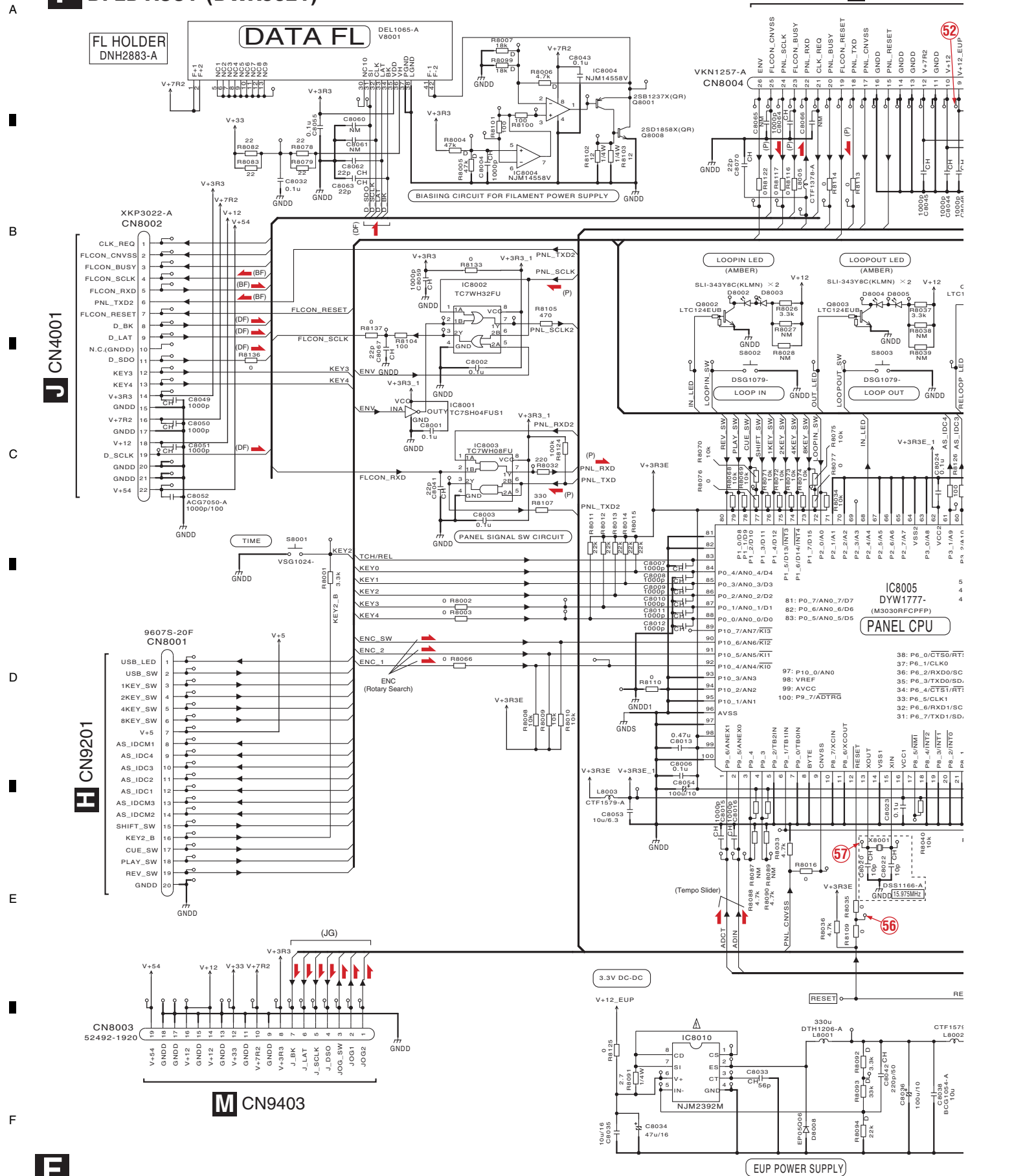

A
B
C
D
E
F

J CN4001

H CN9201

M CN9403

1 2 3 4

10.8 KSWB ASSY

1

2

3

4

F CN8001

CN9201
52492-2020

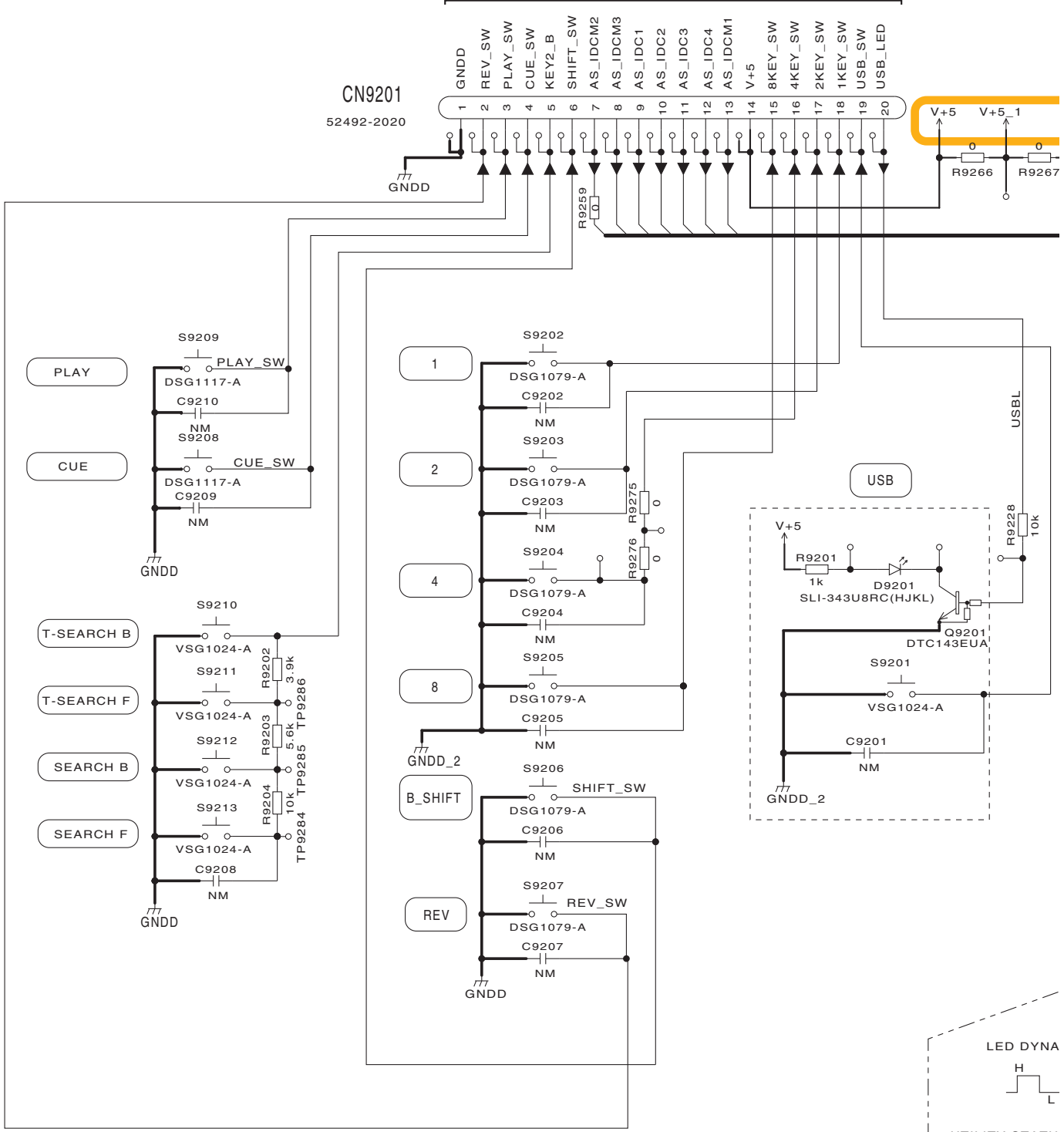

PLAY

CUE

T-SEARCH B

T-SEARCH F

SEARCH B

SEARCH F

1

2

4

8

B_SHIFT

REV

USB

LED DYNA



UTILITY STATU

H	L
760 μ s	760 μ

NOTES

- NM NO MOUNT
- RS1/10SR
- CKSRYB
- GNDD CIRCUIT GND



100

CDJ-900

1

2

3

4

KSWB ASSY (DWS1416)

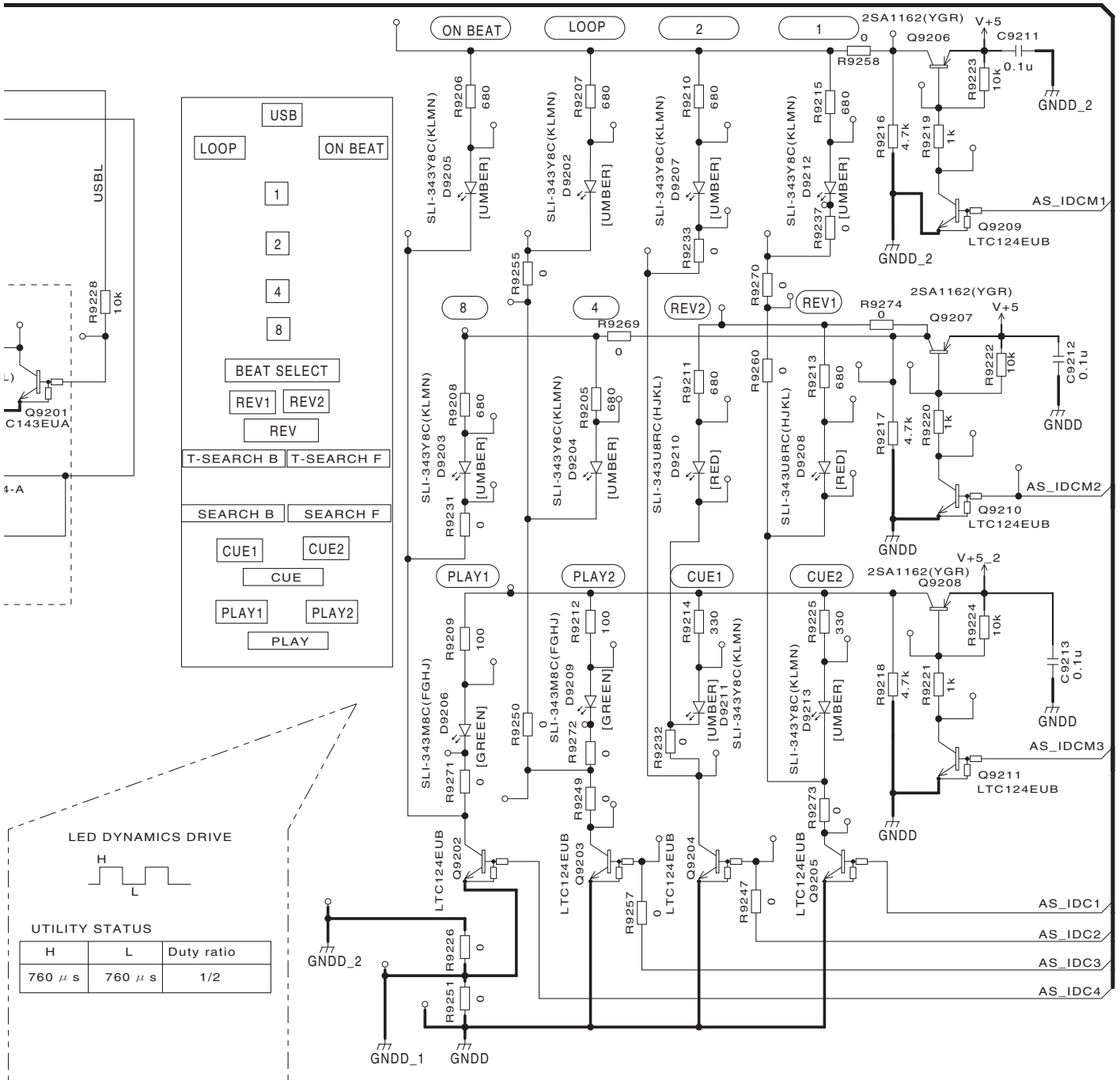
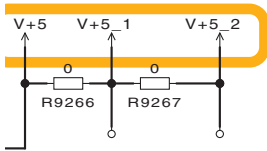

10.9 SLDB ASSY

A
B
C
D
E
F

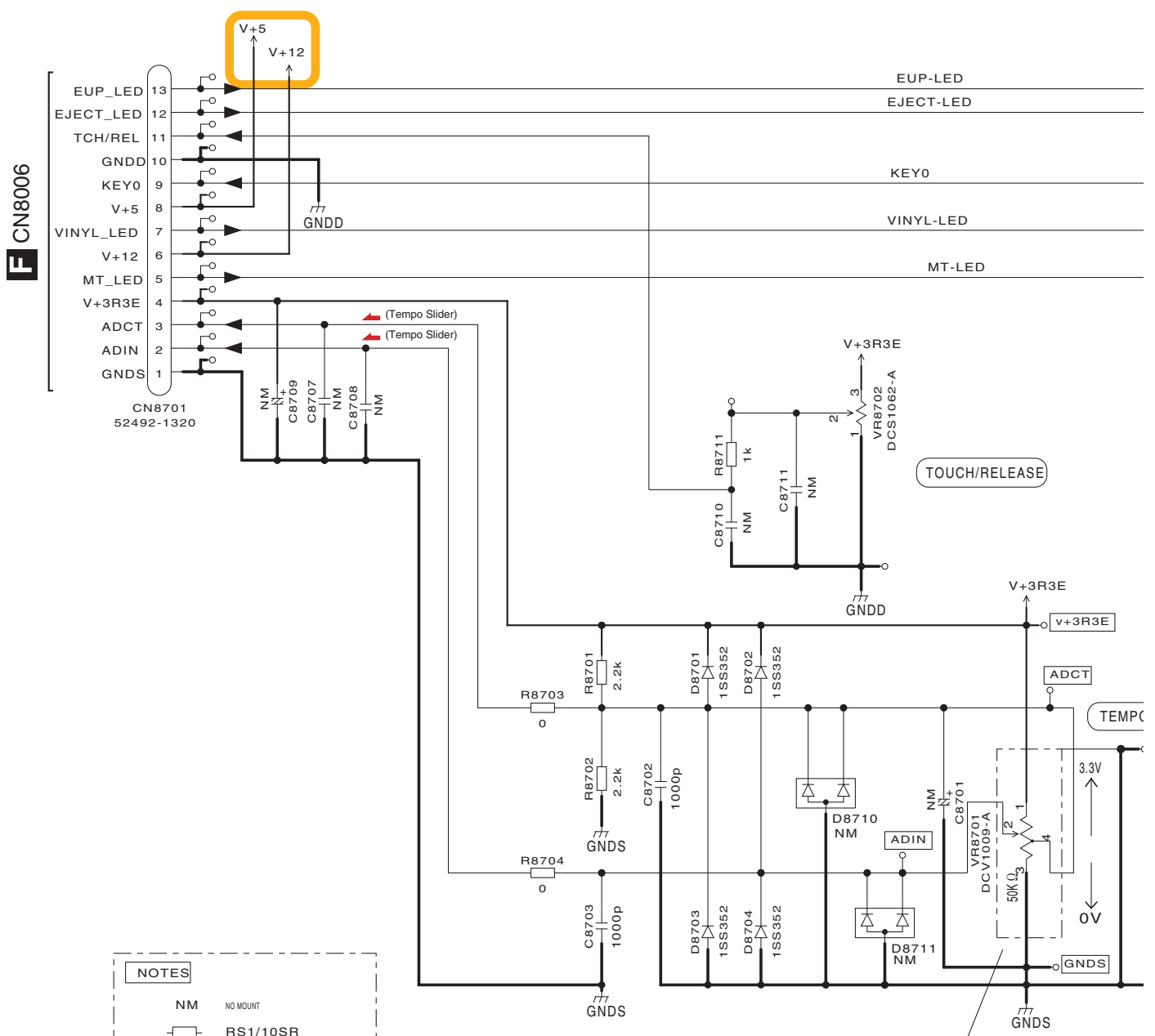

NOTES	
NM	NO MOUNT
	RS1/10SR
	CKSRYB
	CEHAR
	CHASSIS GND
	CIRCUIT GND

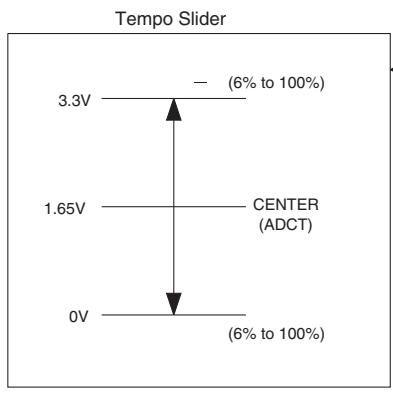

SLDB ASSY (DWS1417)

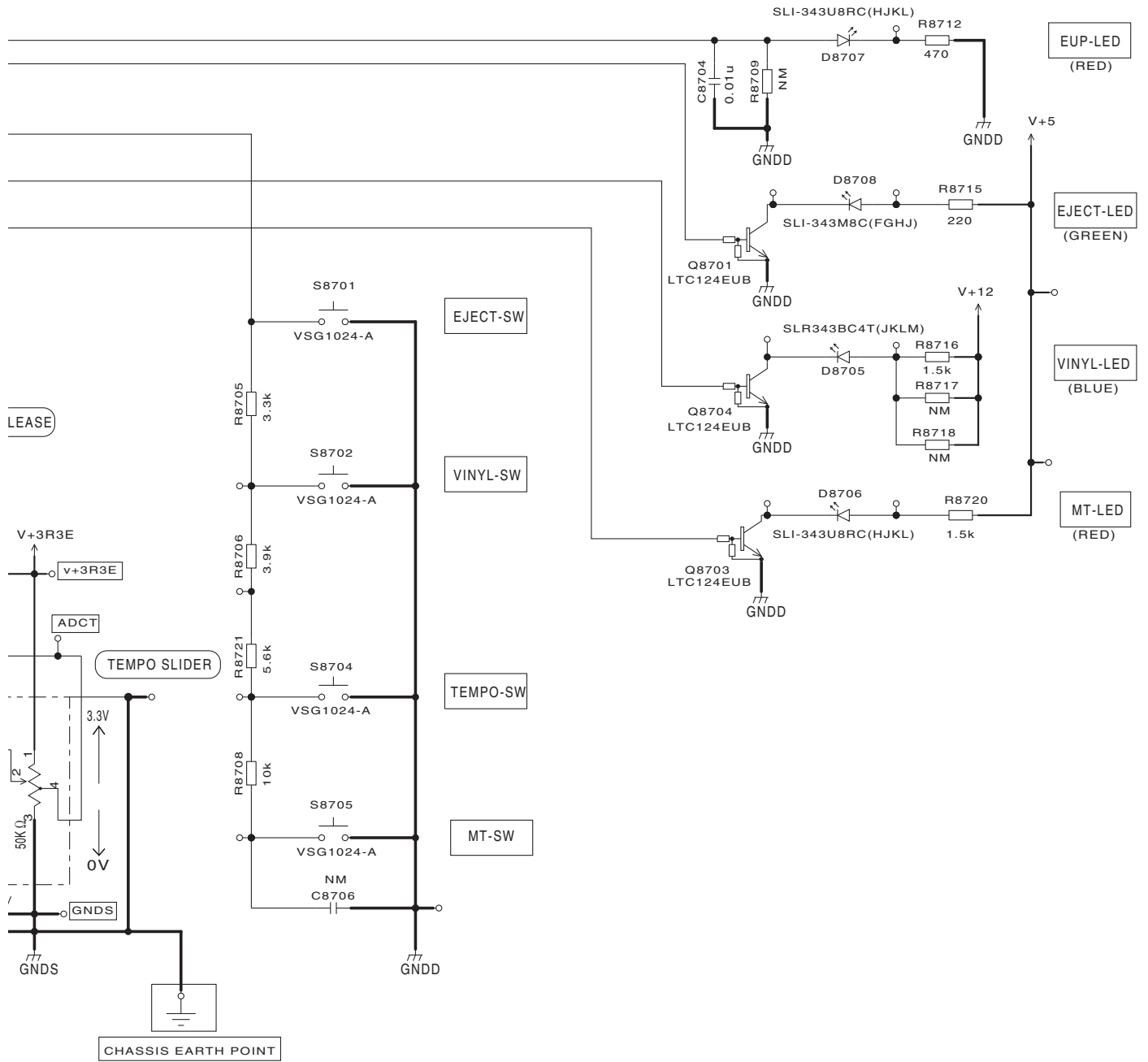

10.10 BFLB ASSY

1

2

3

4

A

B

C

D

E

F

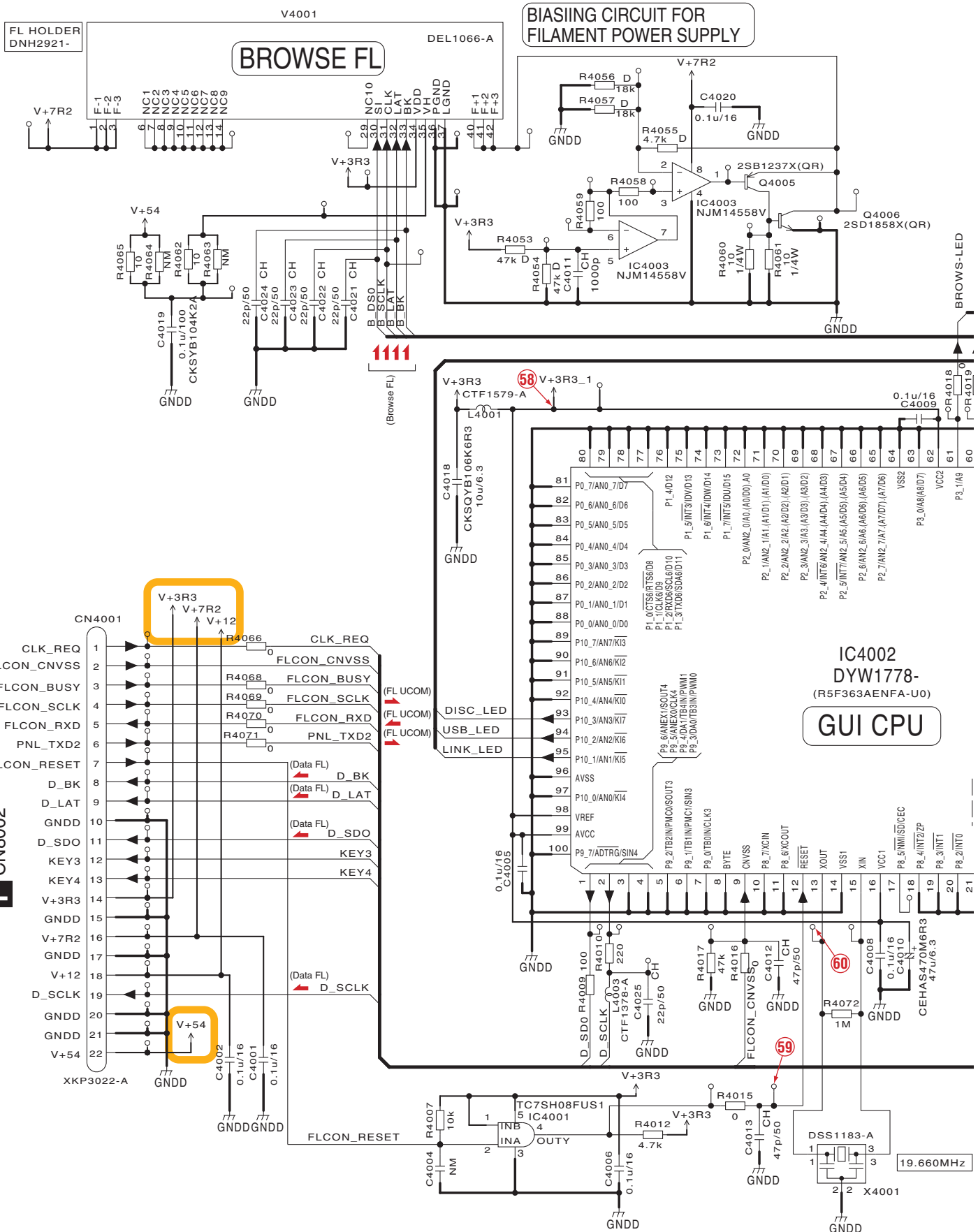

J BFLB ASSY (DWX3025)

NOTES	
NM	NO MOUNT
	RS1/10SR***J
	RS1/4SA***J
	RS1/10SR***D
	CKSRYB
	CCSRCH
	GNDD CIRCUIT GND

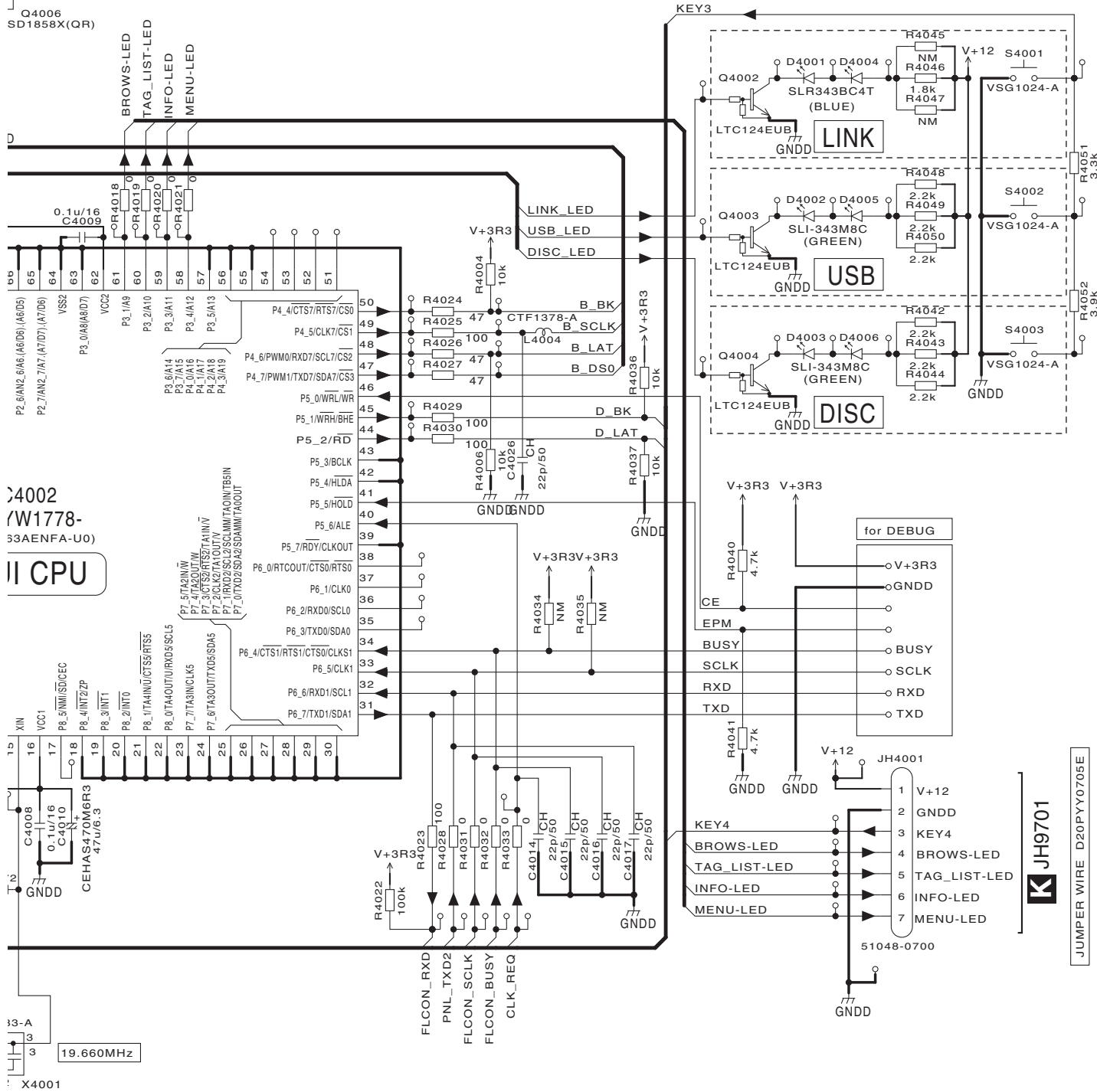

Q4002
W1778-
53AENFA-UO
CPU

X4001

ID

10.11 MSWB ASSY

K MSWB ASSY (DWS1415)

JUMPER WIRE D20PYY0705E

51048-0700
JH9701

J
JH4001

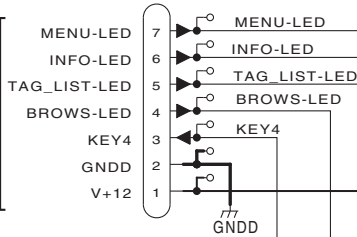

NOTES

- NM NO MOUNT
- RS1/10SR***J
- GNDD CIRCUIT GND

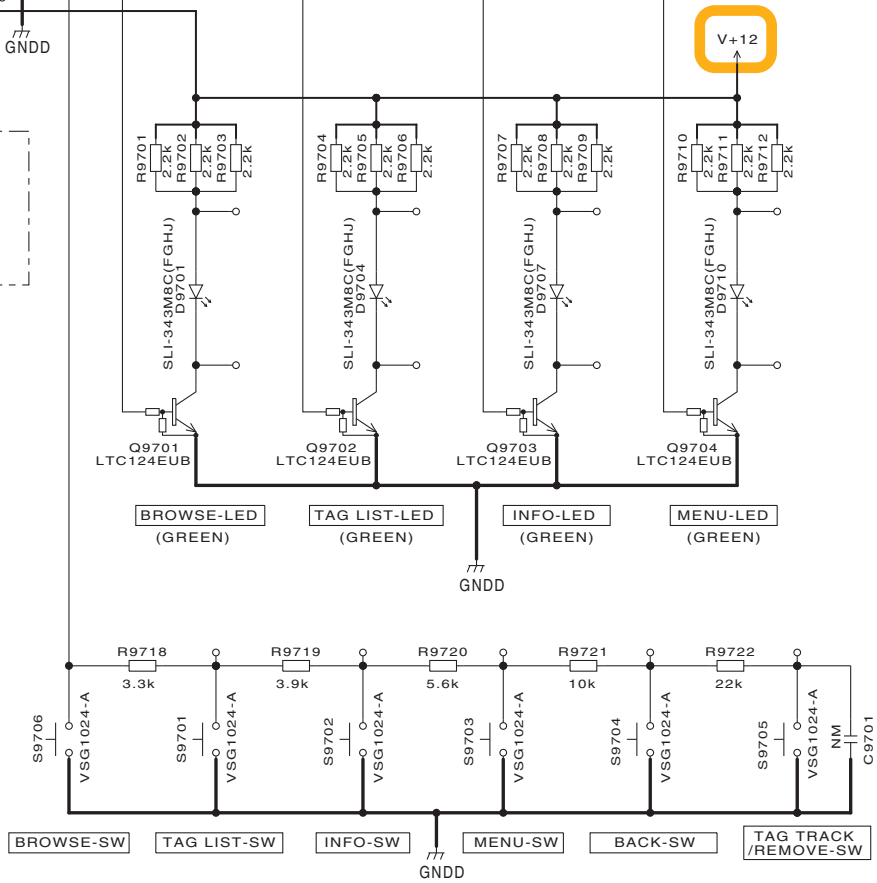

L JOGB ASSY (DWX3026)

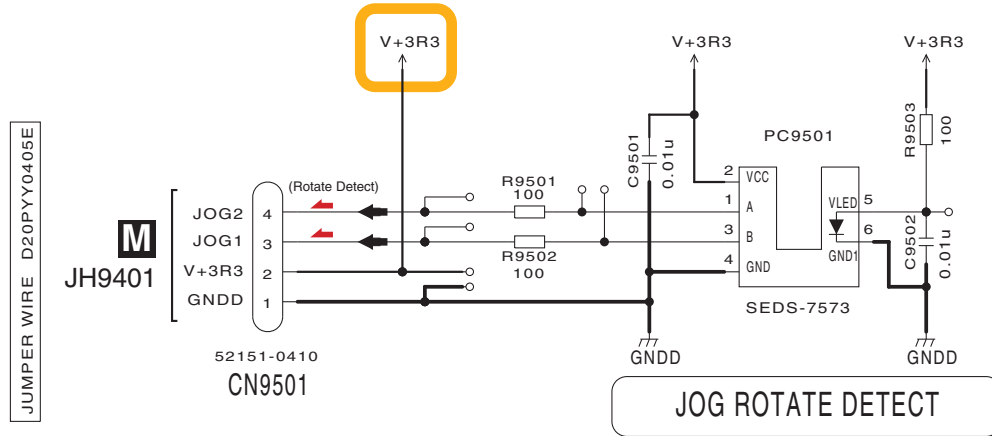

NOTES	
	RS1/10SR***J
	CKSRYB
	GNDD CIRCUIT GND

10.13 JFLB ASSY

V9401
DEL1058-A

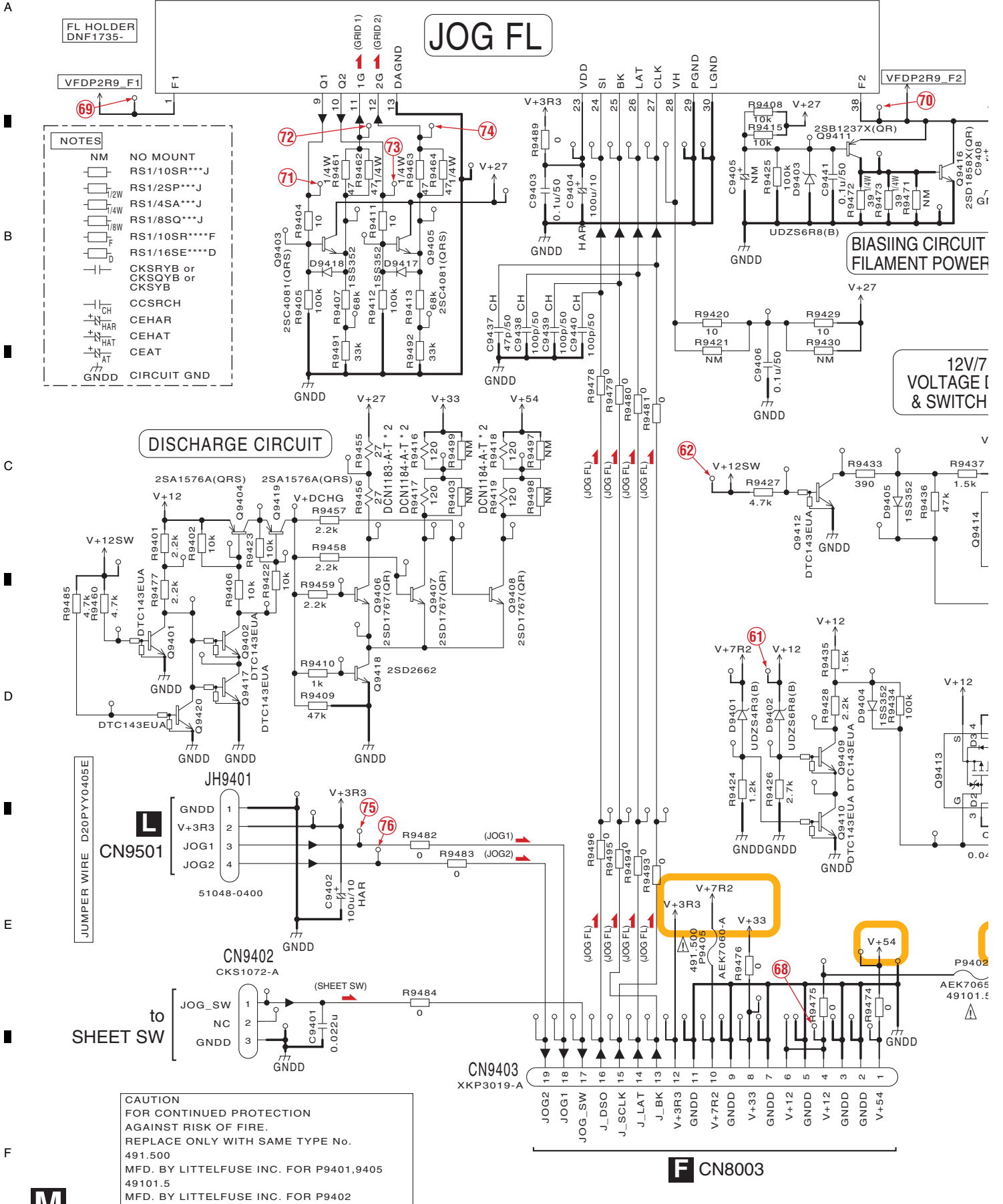

M JFLB ASSY (DWX3024)

A
B
C
D
E
F

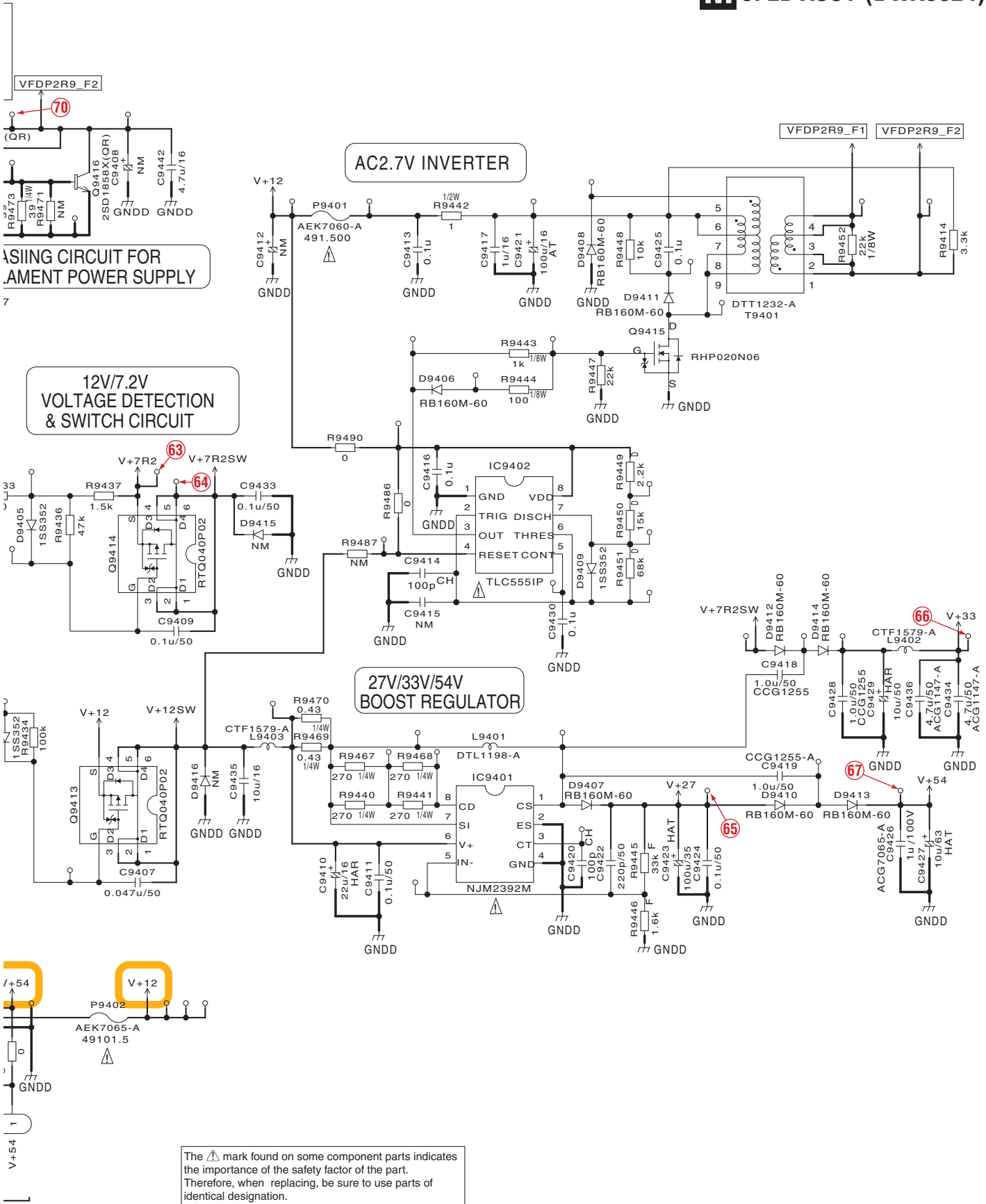

The \triangle mark found on some component parts indicates the importance of the safety factor of the part. Therefore, when replacing, be sure to use parts of identical designation.

The  mark found on some component parts indicates the importance of the safety factor of the part. Therefore, when replacing, be sure to use parts of identical designation.

, AXJ5)

N POWER SUPPLY ASSY (DWR1463)

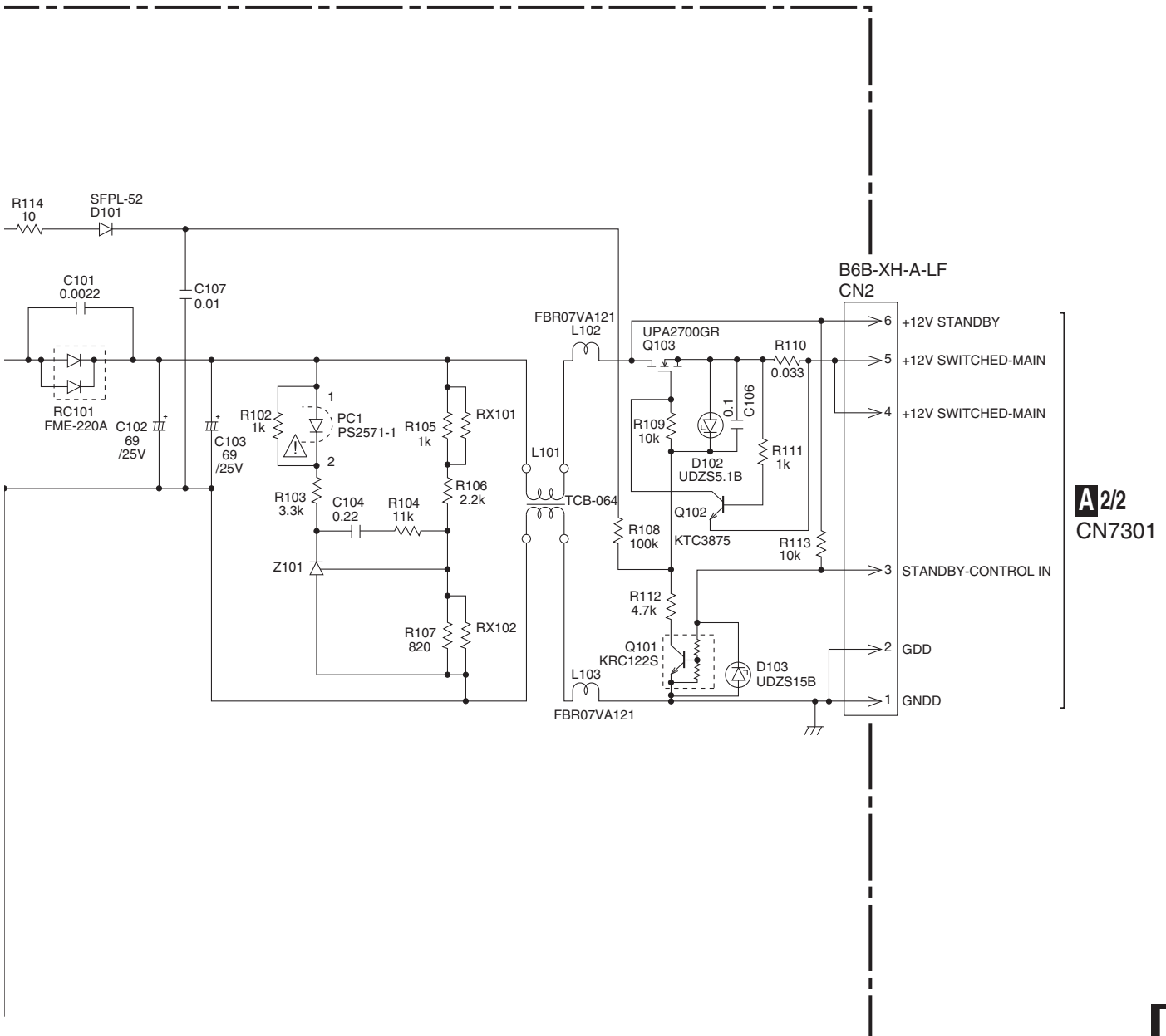

A2/2
CN7301

10.15 WAVEFORMS

NOTE: The encircled numbers denote measuring point in the schematic diagram and PCB diagram.

A SRV ASSY

PLAY (Disc: STD-905)

1 TP-RF (RF)
V: 1.0 V/div. H: 500 msec/div.

SETUP

5 TP-FE (FE)
V: 1.0 V/div. H: 500 msec/div.

6 TP-FEDRV (FEDRV)
V: 1.0 V/div. H: 500 msec/div.

7 TP-TE (TE)
V: 1.0 V/div. H: 500 msec/div.

8 IC7002-pin 26 (SPIN)
V: 2.0 V/div. H: 500 msec/div.

SEARCH

7 TP-TE (TE)
V: 1.0 V/div. H: 20.0 msec/div.

11 TP-TEDRV (TEDRV)
V: 1.0 V/div. H: 20.0 msec/div.

9 IC7002-pin 29 (SLIN1)
V: 5.0 V/div. H: 20.0 msec/div.

10 IC7002-pin 30 (SLIN2)
V: 5.0 V/div. H: 20.0 msec/div.

LOAD IN

2 TP-LPS1 (LPS1)
V: 5.0 V/div. H: 100 msec/div.

3 TP-LPS2 (LPS2)
V: 5.0 V/div. H: 100 msec/div.

4 IC7002-pin 46 (LOAD)
V: 2.0 V/div. H: 100 msec/div.

PLAY

5 TP-FE (FE)
V: 1.0 V/div. H: 2.0 sec/div.

7 TP-TE (TE)
V: 1.0 V/div. H: 2.0 sec/div.

9 IC7002-pin 29 (SLIN1)
V: 2.0 V/div. H: 2.0 sec/div.

10 IC7002-pin 30 (SLIN2)
V: 2.0 V/div. H: 2.0 sec/div.

STOP

5 TP-FE (FE)
V: 1.0 V/div. H: 100 msec/div.

6 TP-FEDRV (FEDRV)
V: 1.0 V/div. H: 100 msec/div.

8 IC7002-pin 26 (SPIN)
V: 2.0 V/div. H: 100 msec/div.

13 IC7002-pin 43 (SPDFLG)
V: 5.0 V/div. H: 100 msec/div.

LOAD OUT

2 TP-LPS1 (LPS1)
V: 5.0 V/div. H: 200 msec/div.

3 TP-LPS2 (LPS2)
V: 5.0 V/div. H: 200 msec/div.

4 IC7002-pin 46 (LOAD)
V: 2.0 V/div. H: 200 msec/div.

PAUSE

7 TP-TE (TE)
V: 1.0 V/div. H: 200 μsec/div.

11 TP-TEDRV (TEDRV)
V: 1.0 V/div. H: 200 μsec/div.

1 TP-RF (RF)
V: 500 mV/div. H: 200 μsec/div.

12 TP-OFTR (OFTR)
V: 5.0 V/div. H: 200 μsec/div.

T CLOSE

14 TP-E (E)
V: 2.0 V/div. H: 100 msec/div.

15 TP-F (F)
V: 2.0 V/div. H: 100 msec/div.

7 TP-TE (TE)
V: 1.0 V/div. H: 100 msec/div.

11 TP-TEDRV (TEDRV)
V: 1.0 V/div. H: 100 msec/div.

IN FOCUS

5 TP-FE (FE)
V: 1.0 V/div. H: 100 msec/div.

6 TP-FEDRV (FEDRV)
V: 500 mV/div. H: 100 msec/div.

TRACK SEARCH

7 TP-TE (TE)
V: 1.0 V/div. H: 20.0 msec/div.

11 TP-TEDRV (TEDRV)
V: 1.0 V/div. H: 20.0 msec/div.

9 IC7002-pin 29 (SLIN1)
V: 5.0 V/div. H: 20.0 msec/div.

10 IC7002-pin 30 (SLIN2)
V: 5.0 V/div. H: 20.0 msec/div.

C MAIN ASSY

MODE: POWER ON

16 TP-V+12 (V+12)
V: 10.0 V/div. H: 40 msec/div.

17 TP-V+10A (V+10A)
V: 10.0 V/div. H: 40 msec/div.

18 CN501-pin 6 (V-10A)
V: 10.0 V/div. H: 40 msec/div.

19 Q1309-pin 6 (V+5A)
V: 5.0 V/div. H: 40 msec/div.

MODE: POWER ON Trigger: CH4, 3.4 V

16 TP-V+12 (V+12)
V: 10.0 V/div. H: 10 msec/div.

20 TP-V+5 (V+5)
V: 5.0 V/div. H: 10 msec/div.

21 TP-V+3R3 (V+3R3)
V: 2.0 V/div. H: 10 msec/div.

22 TP-V+1R2 (V+1R2)
V: 1.0 V/div. H: 10 msec/div.

MODE: POWER ON Trigger: CH1, 2 V

23 F101-pin2 (V+3R3_CPU) 20 MHz FILTER
V: 1.0 V/div. H: 40 msec/div.

24 IC119-pin 6 (FLASH_CS)
V: 1.0 V/div. H: 40 msec/div.

MODE: POWER ON Trigger: CH1, 2 V

23 F101-pin2 (V+3R3_CPU) 20 MHz FILTER
V: 1.0 V/div. H: 4.0 msec/div.

25 IC108-pin 38 (CPU_CLKOUT)
V: 1.0 V/div. H: 4.0 msec/div.

C MAIN ASSY

MODE: POWER ON Trigger: CH1, 2 V

26 Foot of R1108 (V+3R3_USB_CORE)
V: 2.0 V/div. H: 40 msec/div.

27 IC123-pin 8 (USB_RST)
V: 2.0 V/div. H: 40 msec/div.

28 IC1101-pin 14 (X'tal (USB_CLK))
V: 2.0 V/div. H: 40 msec/div.

MODE: IDLING Trigger: CH1, 2 V

35 Foot of R3079 (CLKIN)
V: 500 mV/div. H: 80.0 nsec/div.

MODE: IDLING Trigger: CH1, 1 V

38 Foot of R3121 (X'TAL)
V: 500 mV/div. H: 40.0 nsec/div.

MODE: IDLING (USB connect) Trigger: CH1, 200 mV

45 JA1101-pin 3 (USB_D+)
V: 2.0 V/div. H: 400 µsec/div.

46 JA1101-pin 2 (USB_D-)
V: 2.0 V/div. H: 400 µsec/div.

MODE: POWER ON Trigger: CH1, 2 V

29 F1302-pin 1 (V+3R3_ETH)
V: 2.0 V/div. H: 1.0 sec/div.

30 IC1304-pin 42 (ETHER_RST)
V: 2.0 V/div. H: 1.0 sec/div.

31 IC1304-pin 46 (X'tal)
V: 1.0 V/div. H: 1.0 sec/div.

MODE: IDLING Trigger: CH1, 1 V

36 IC1304-pin 45 (X1)
V: 500 mV/div. H: 80.0 nsec/div.

31 IC1304-pin 46 (X2)
V: 500 mV/div. H: 80.0 nsec/div.

MODE: IDLING Trigger: CH1, 1 V

39 Foot of L103 (V+1R2_CPU) 20 MHz FILTER
V: 1.0 V/div. H: 40.0 msec/div.

40 Foot of TP106 (V+3R3_CPU)
V: 2.0 V/div. H: 40.0 msec/div.

23 F101-pin 2 (CPU_RST)
V: 2.0 V/div. H: 40.0 msec/div.

38 Foot of R3121 (X'TAL)
V: 2.0 V/div. H: 40.0 msec/div.

MODE: FADER START & BACK CUE Trigger: CH1, 2.0 V

47 CN501-pin 9 (CONT1)
V: 2.0 V/div. H: 40 msec/div.

48 CN501-pin 10 (CONT2)
V: 2.0 V/div. H: 40 msec/div.

MODE: POWER ON Trigger: CH1, 2 V

32 IC505-pin 43 (V+3R3_DSP)
V: 1.0 V/div. H: 4.0 msec/div.

33 IC505-pin 38 (DSP_CLK)
V: 1.0 V/div. H: 4.0 msec/div.

MODE: IDLING Trigger: CH1, 1 V

28 IC1101-pin 14 (USB_CLK)
V: 500 mV/div. H: 20.0 nsec/div.

MODE: IDLING Trigger: CH1, 1 V

41 Foot of TP3005(V+1R2_CPU) 20 MHz FILTER
V: 1.0 V/div. H: 400 msec/div.

22 Foot of C596 (V+1R2)
V: 2.0 V/div. H: 400 msec/div.

42 Foot of TP168 (DSP710_RST)
V: 2.0 V/div. H: 400 msec/div.

35 Foot of R3079 (CLKIN)
V: 2.0 V/div. H: 400 msec/div.

MODE: IDLING Trigger: CH1, 100 mV

49 CN501-pin 12 (SPDIF)
V: 200 mV/div. H: 400 nsec/div.

MODE: IDLING Trigger: CH1, 2 V

34 IC3003-pin 4 (DAC_MCLK)
V: 500 mV/div. H: 80.0 nsec/div.

MODE: IDLING Trigger: CH1, 2 V

37 IC115-pin 5 (USB_CLK)
V: 500 mV/div. H: 20.0 nsec/div.

MODE: IDLING (USB connect) Trigger: CH1, 200 mV

43 F1102-pin 2 (CPU_USB_D+)
V: 500 mV/div. H: 100 µsec/div.

44 F1102-pin 1 (CPU_USB_D-)
V: 500 mV/div. H: 100 µsec/div.

MODE: PLAY (1k 0dB) Trigger: CH1, 2.5 V

50 CN501-pin 2 (ROUT)
V: 1.0 V/div. H: 400 µsec/div.

51 CN501-pin 5 (LOUT)
V: 1.0 V/div. H: 400 µsec/div.

A

B

C

D

E

F

F DFLB ASSY

MODE: POWER ON Trigger: CH4, 3.4 V

52 TP-V+12_EUP (V+12_EUP)
V: 10.0 V/div. H: 400 msec/div.

53 IC8007-pin 5 (V+3R3E)
V: 2.0 V/div. H: 400 msec/div.

54 CN8004-pin 2 (EUP_CONT)
V: 2.0 V/div. H: 400 msec/div.

55 TP-V+12 (V+12)
V: 10.0 V/div. H: 400 msec/div.

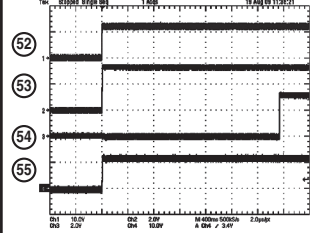

MODE: POWER ON Trigger: CH1, 2 V

53 IC8007-pin 5 (V+3R3E)
V: 1.0 V/div. H: 40.0 msec/div.

56 Foot of R8109 (PNL_RESET#)
V: 1.0 V/div. H: 40.0 msec/div.

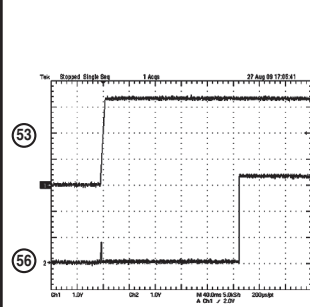

MODE: IDLING Trigger: CH1, 2 V

57 IC8005-pin 13 (XOUT)
V: 500 mV/div. H: 80.0 nsec/div.

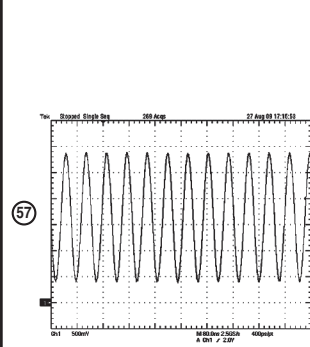

J BFLB ASSY

MODE: POWER ON Trigger: CH1, 2 V

58 J4002 (V+3R3_1)
V: 1.0 V/div. H: 40.0 msec/div.

59 IC4002-pin 12 (RESET)
V: 1.0 V/div. H: 40.0 msec/div.

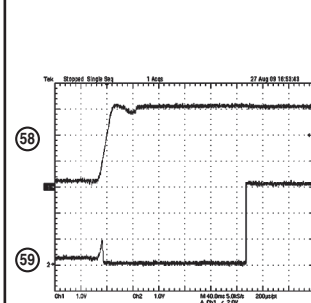

MODE: IDLING Trigger: CH1, 2 V

60 IC4002-pin 13 (XOUT)
V: 500 mV/div. H: 80.0 nsec/div.

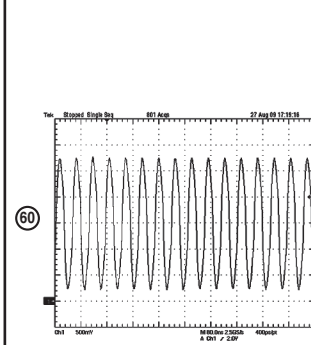

M JFLB ASSY

MODE: POWER ON Trigger: CH4, 3.4 V

61 D9402 Cathode (V+12)
V: 10.0 V/div. H: 20 msec/div.

62 TP-V+12SW (V+12SW)
V: 10.0 V/div. H: 20 msec/div.

63 Q9414-pin 4 (V+7R2)
V: 5.0 V/div. H: 20 msec/div.

64 TP-V+7R2SW (V+7R2SW)
V: 5.0 V/div. H: 20 msec/div.

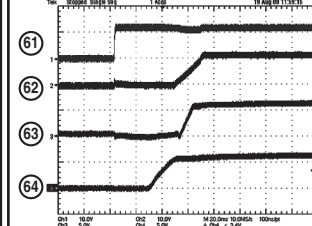

MODE: POWER ON Trigger: CH4, 15 V

62 TP-V+12SW (V+12SW)
V: 10.0 V/div. H: 10 msec/div.

65 TP-V+27 (V+27)
V: 20.0 V/div. H: 10 msec/div.

66 Foot of L9402 (V+33)
V: 20.0 V/div. H: 10 msec/div.

67 TP-V+54 (V+54)
V: 50.0 V/div. H: 10 msec/div.

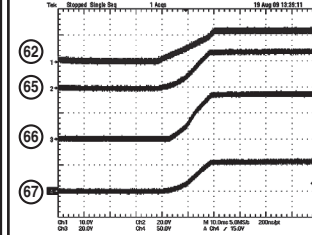

MODE: POWER ON Trigger: CH1, 5 V

68 CN9403-pin 4 (V+12)
V: 10.0 V/div. H: 100 msec/div.

69 TP-VFDP2R9_F1 (VFDP2R9_F1)
V: 5.0 V/div. H: 100 msec/div.

70 TP-VFDP2R9_F2 (VFDP2R9_F2)
V: 10.0 V/div. H: 100 msec/div.

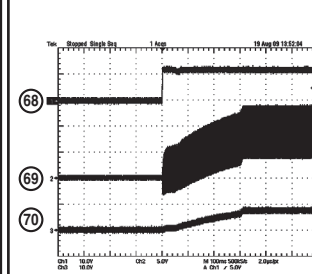

MODE: IDLING Trigger: CH1, 15 V

71 TP-Q1 (Q1)
V: 50 V/div. H: 400 µsec/div.

72 TP-1G (1G)
V: 50 V/div. H: 400 µsec/div.

73 TP-Q2 (Q2)
V: 50 V/div. H: 400 µsec/div.

74 TP-2G (2G)
V: 50 V/div. H: 400 µsec/div.

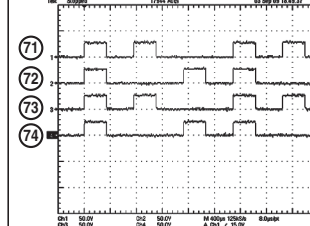

MODE: JOG SPIN Trigger: CH1, 2 V

75 TP-JOG1 (JOG1)
V: 1.0 V/div. H: 20 msec/div.

76 TP-JOG2 (JOG2)
V: 1.0 V/div. H: 20 msec/div.

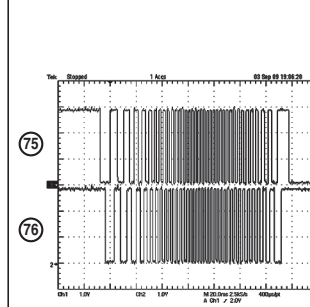



5



6



7



8



A



B



C



D



E



F



5



6

CDJ-900



7



8



11. PCB CONNECTION DIAGRAM

11.1 SRV and SLMB ASSYS

A SIDE A

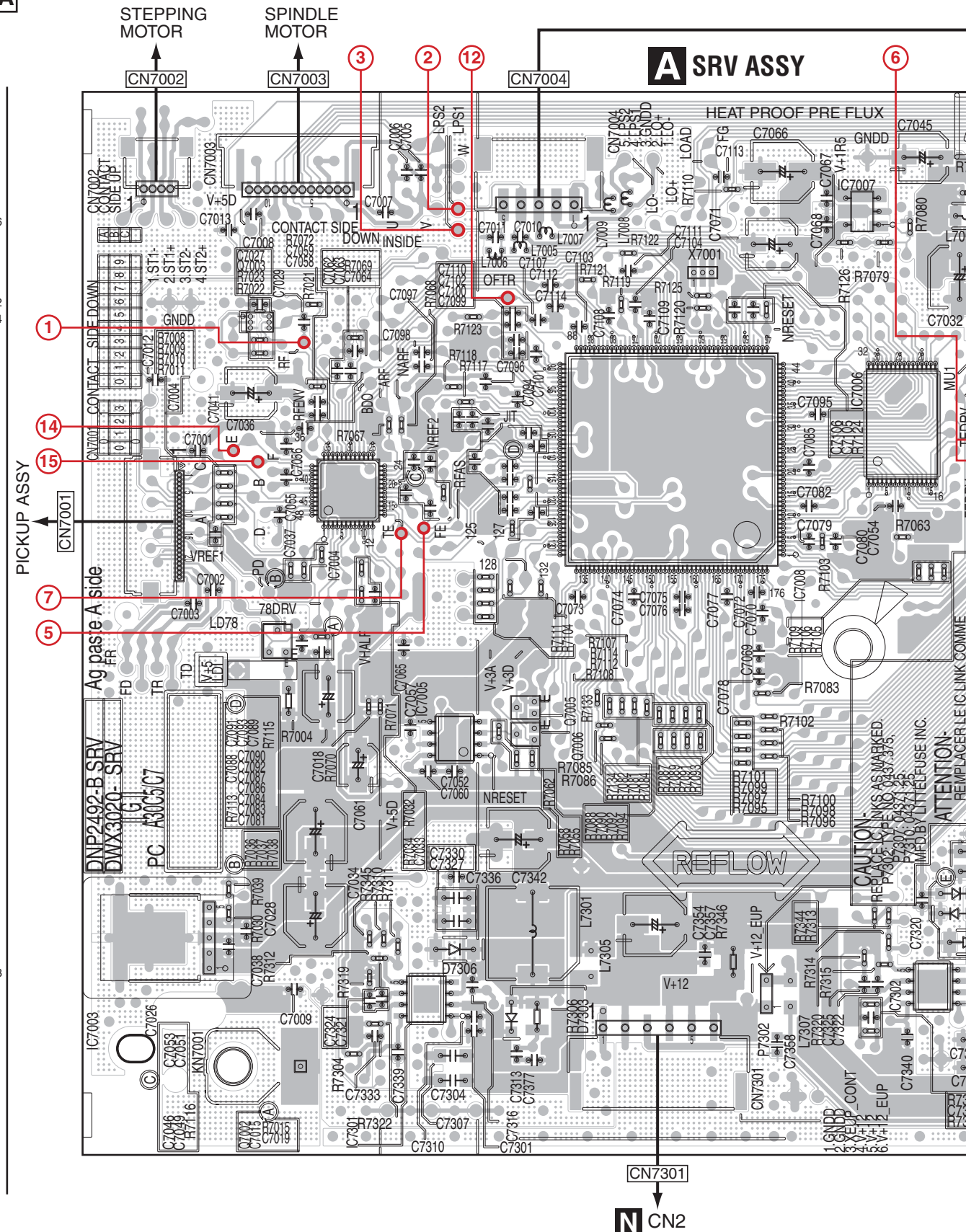

NOTE: The encircled numbers denote measuring point.

SIDE A

A

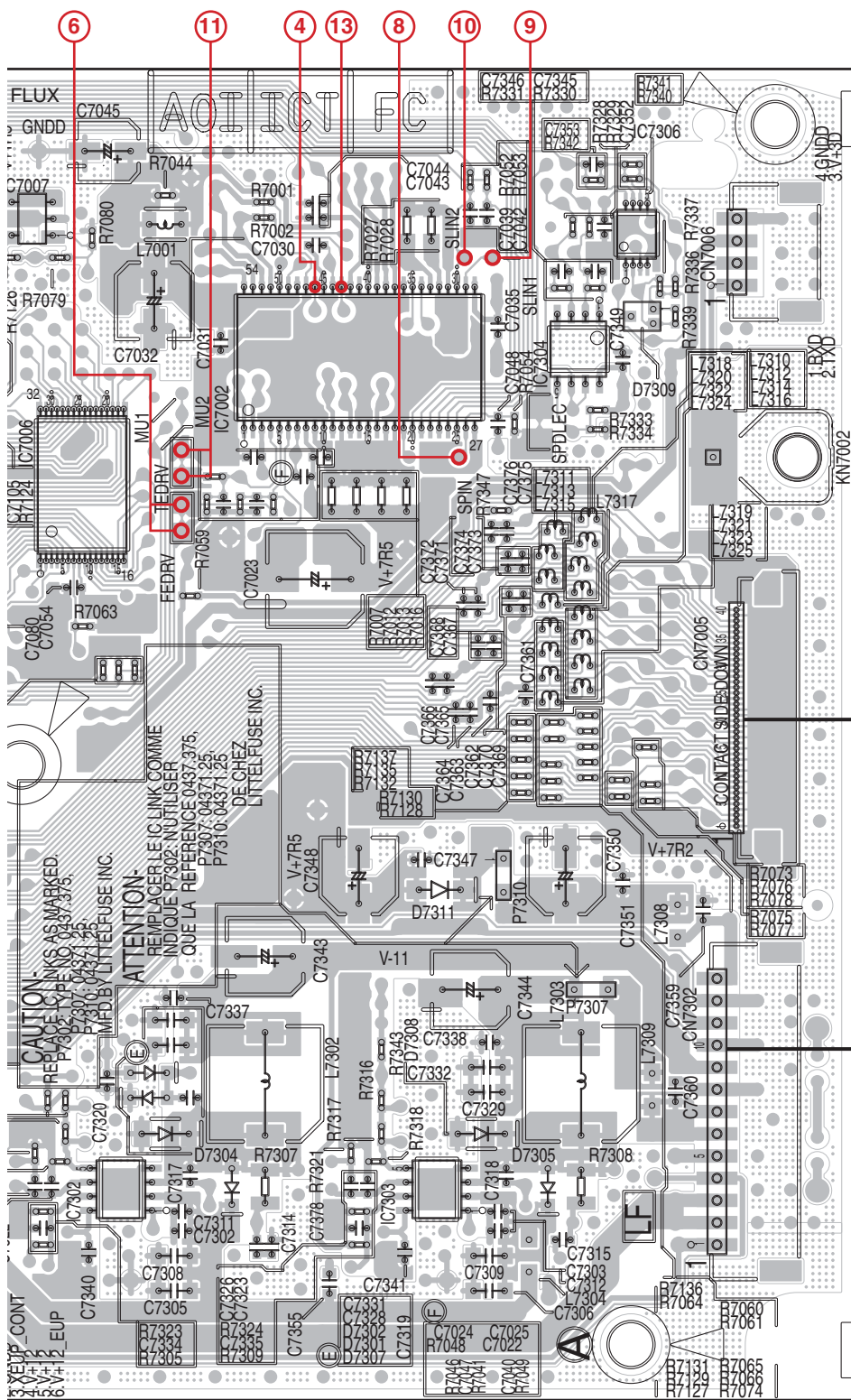

(DNP2492-B)

B SLMB ASSY

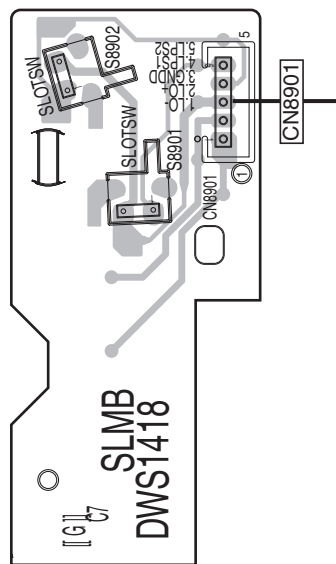

(DNP2493-C)

C CN1303

C CN3001

NOTE FOR PCB DIAGRAMS :

1. The parts mounted on this PCB include all necessary parts for several destinations. For further information for respective destinations, be sure to check with the schematic diagram.

2. View point of PCB diagrams.

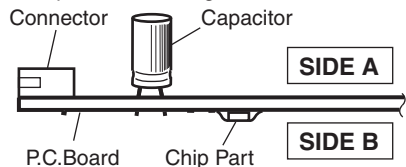

SIDE A

SIDE B

B

C

D

E

F

SIDE B

A
B
C
D
E
F

B SLMB ASSY

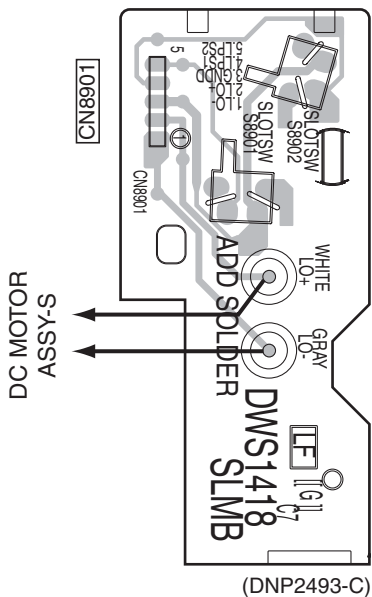

A SRV ASSY

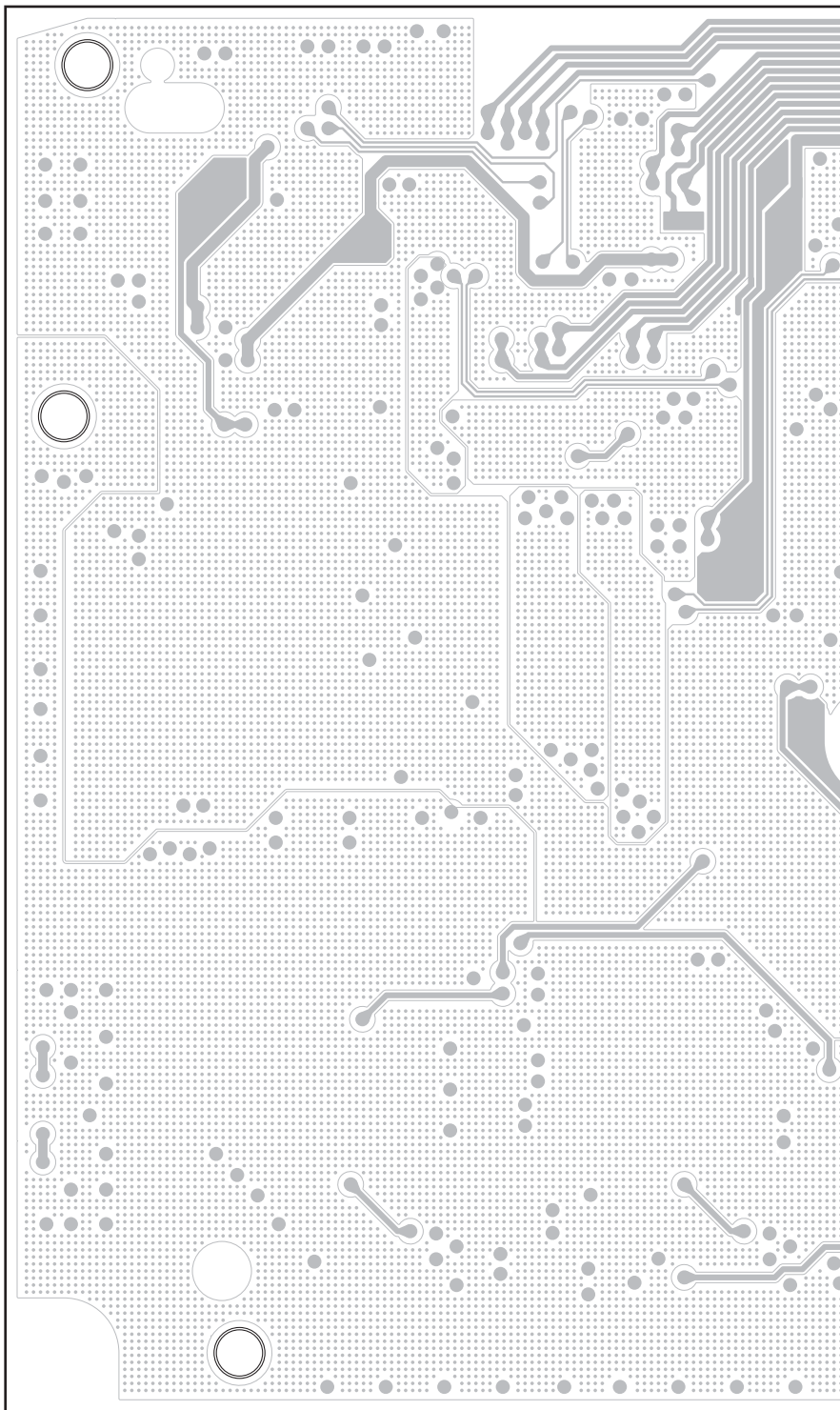

SIDE B

A

B

C

D

E

F

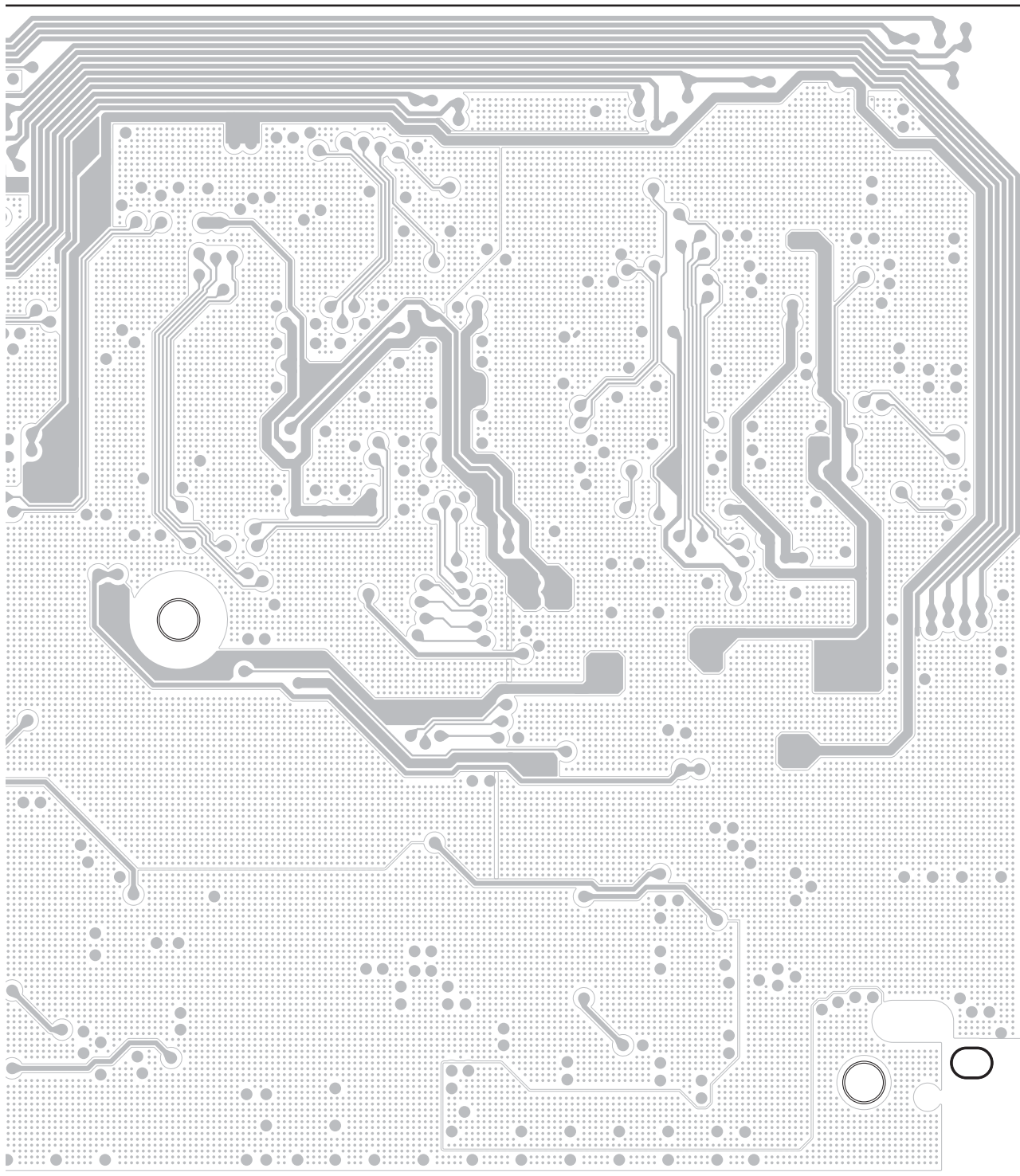

(DNP2492-B)

11.2 MAIN ASSY

SIDE A

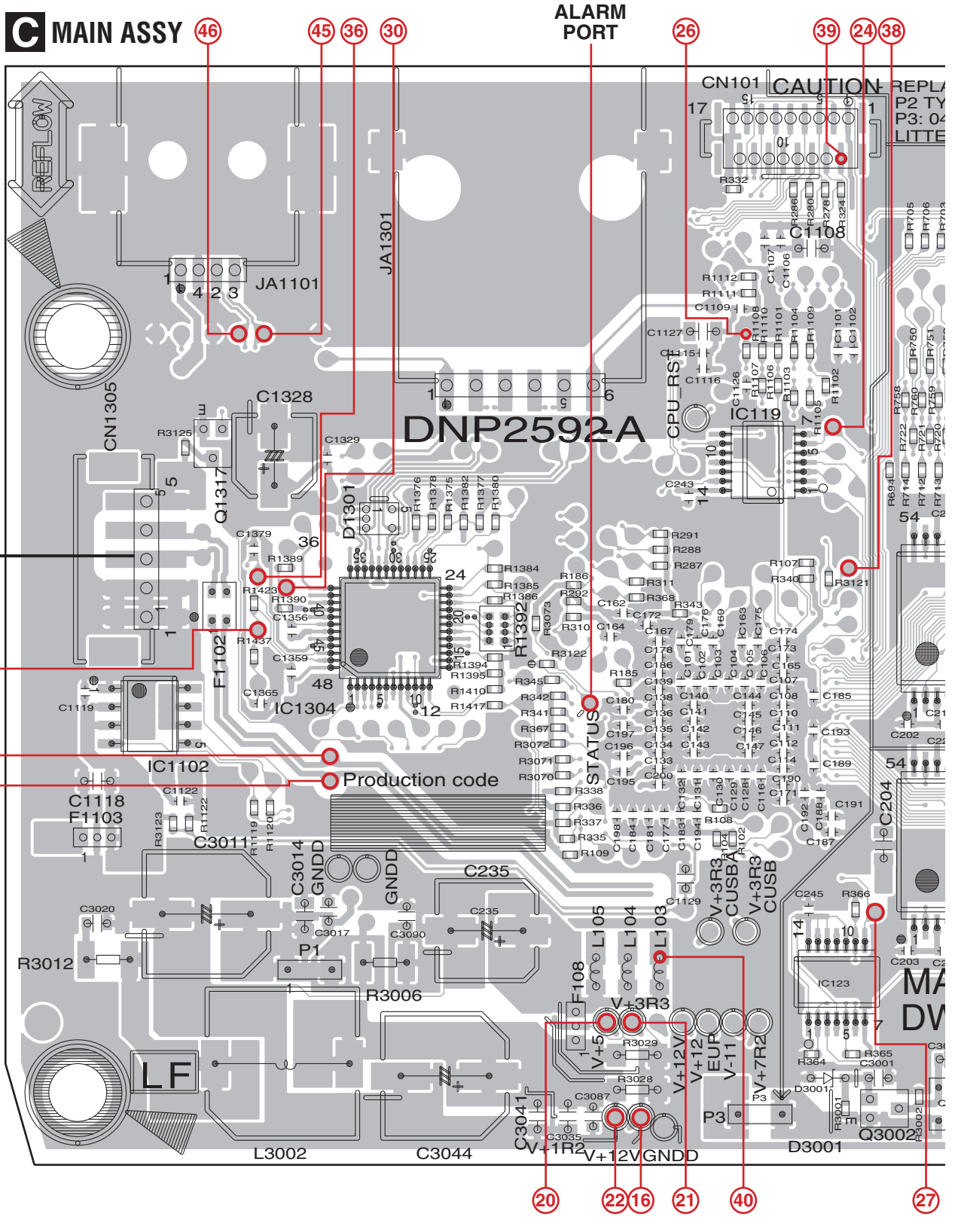

C

120

CDJ-900

NOTE: The encircled numbers denote measuring point.

SIDE A

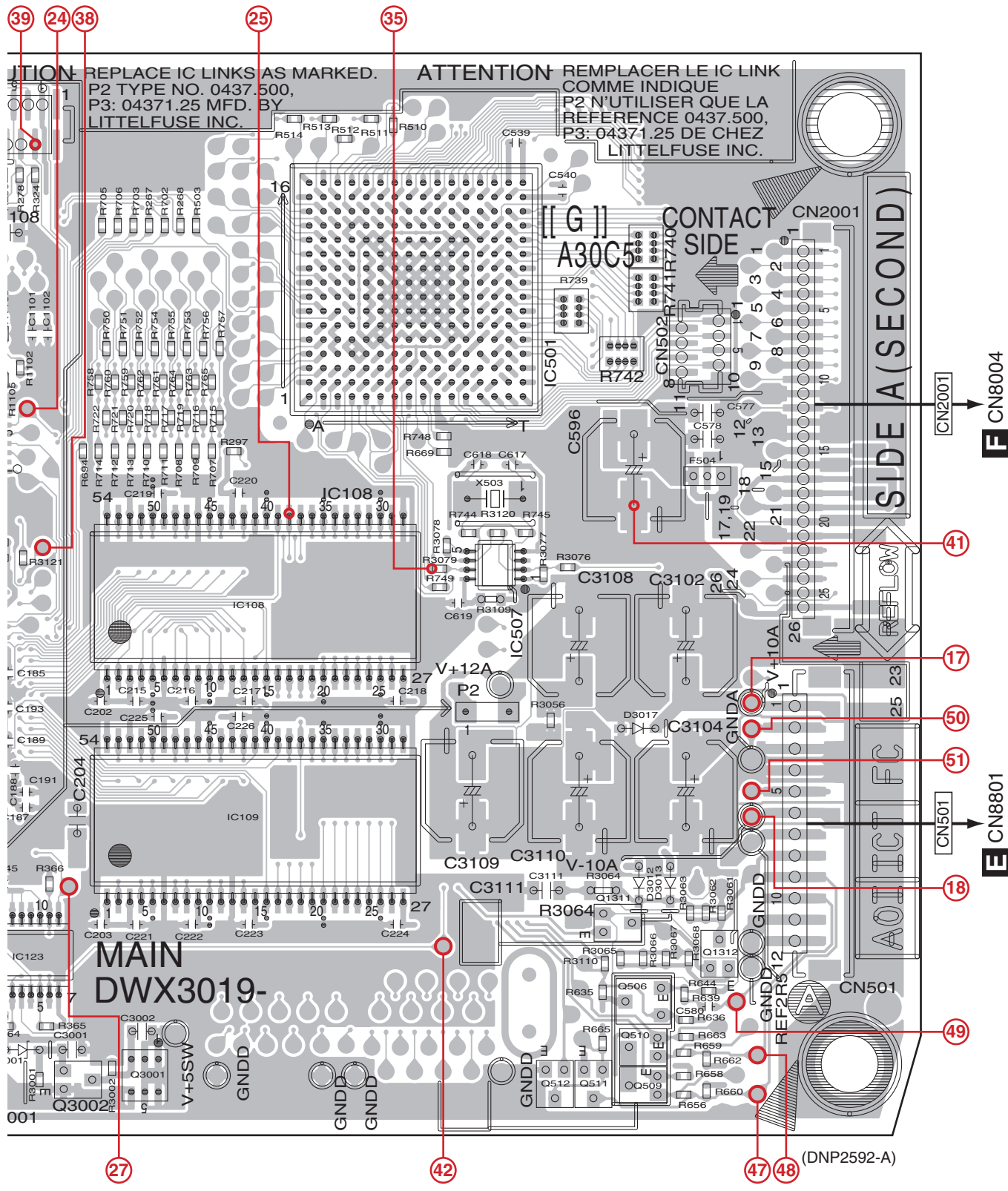

C123	IC108	IC501	IC507	Q1311	Q578
Q3002	IC109			Q511	Q1312
Q3001				Q510	
				Q509	

SIDE B

C MAIN ASSY

A
B
C
D
E
F

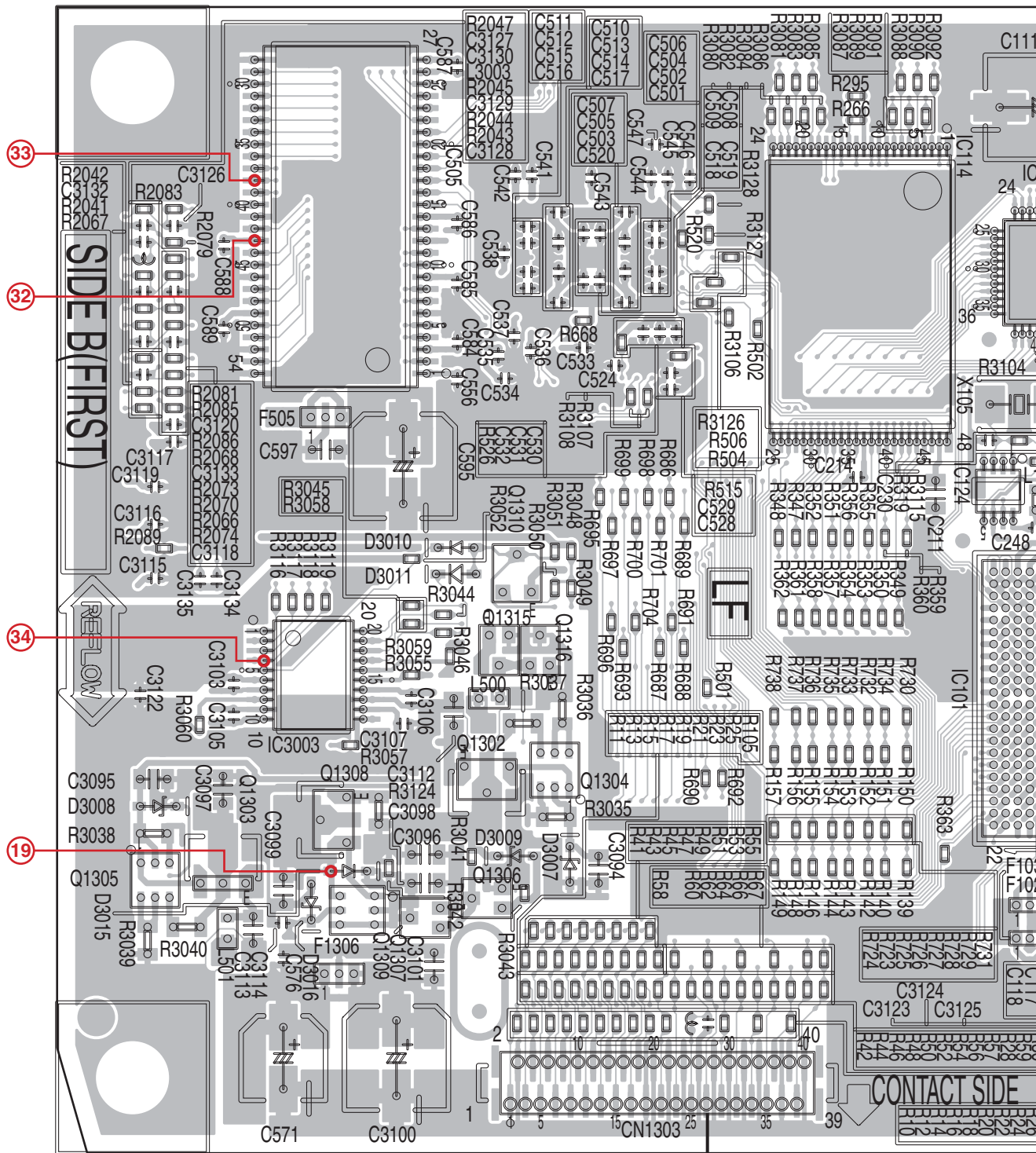

33

32

34

19

CN1303
A CN7005

IC505
IC3003
Q1305
Q1303
Q1308
Q1307

Q1310
Q1315
Q1316
Q1302
Q1306
Q1304

IC114
IC124

CDJ-900

NOTE: The encircled numbers denote measuring point.

SIDE B

A
B
C
D
E
F

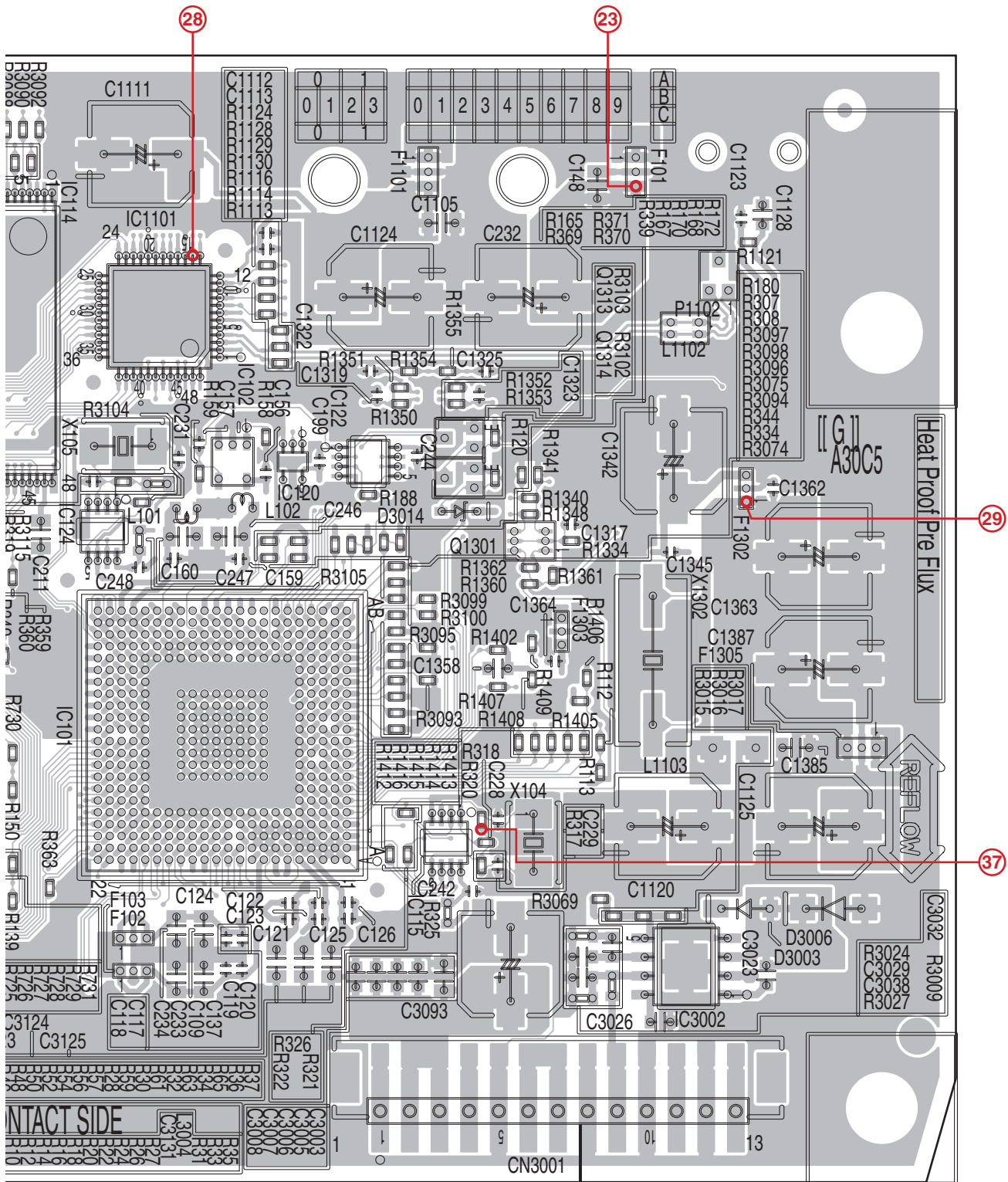

CONTACT SIDE (DNP2592-A)

A CN7302

IC1101 IC102 IC120 IC122 Q1301 IC124 IC101 IC3002 IC115

CDJ-900

C

11.3 USBA and JACKB ASSYS

SIDE A

D USBA ASSY

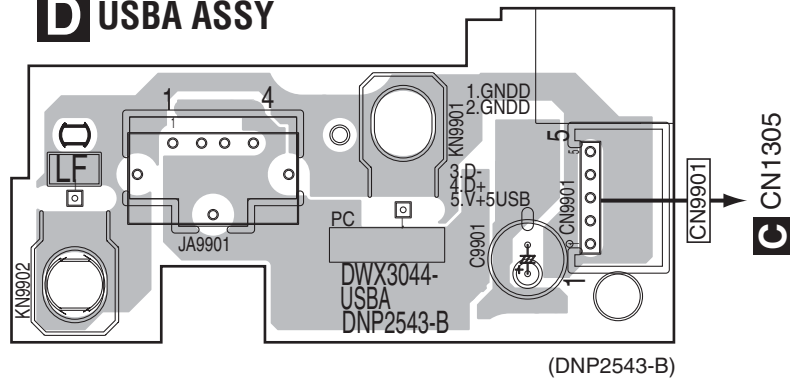

E JACB ASSY

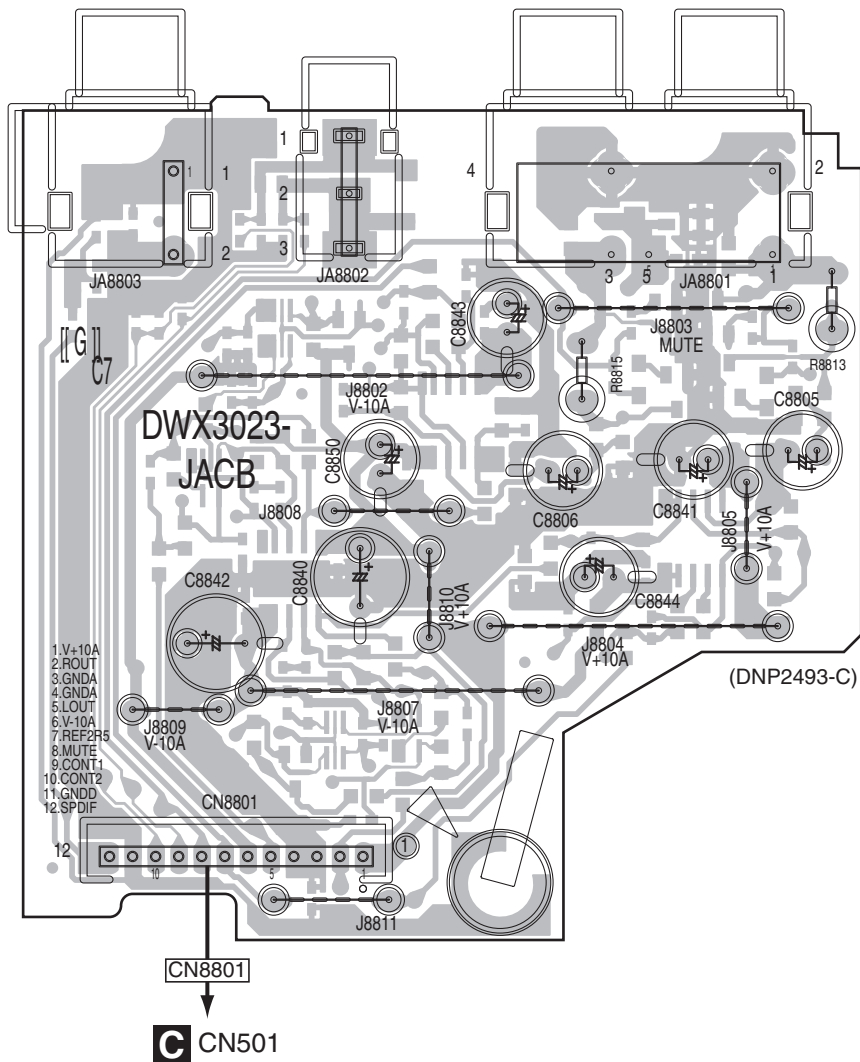

SIDE B

A

B

C

D

E

F

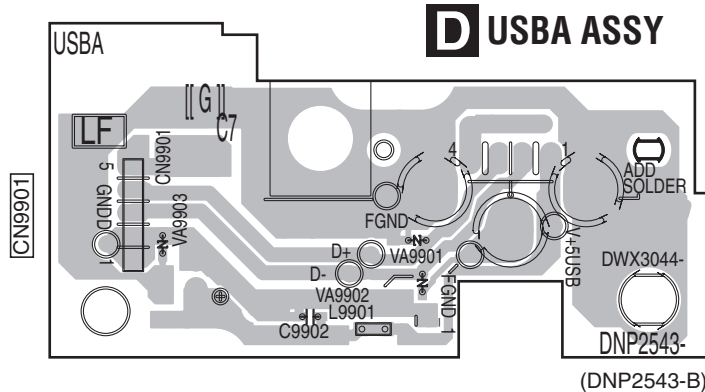

E JACB ASSY

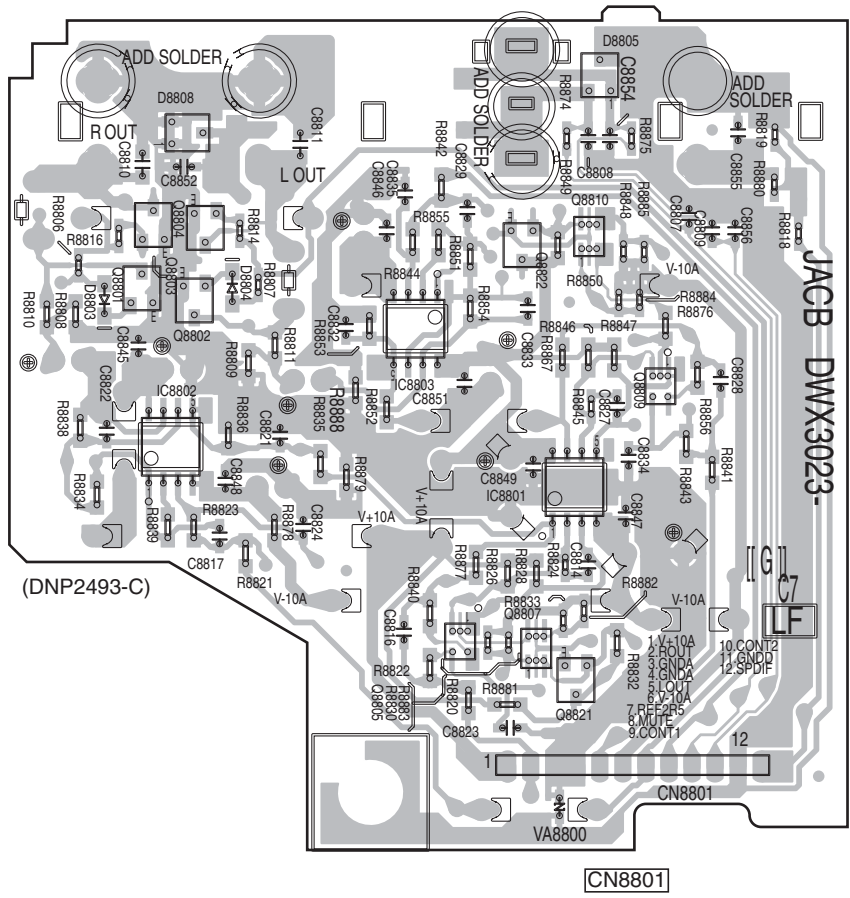

- Q8803 Q8804 Q8822 Q8810
- Q8801 Q8802 IC8803 Q8809
- IC8802 IC8801 IC8801
- Q8805 Q8807 Q8821

11.4 DFLB and ENCB ASSYS

SIDE A

A
B
C
D
E
F

F DFLB ASSY

M CN9403

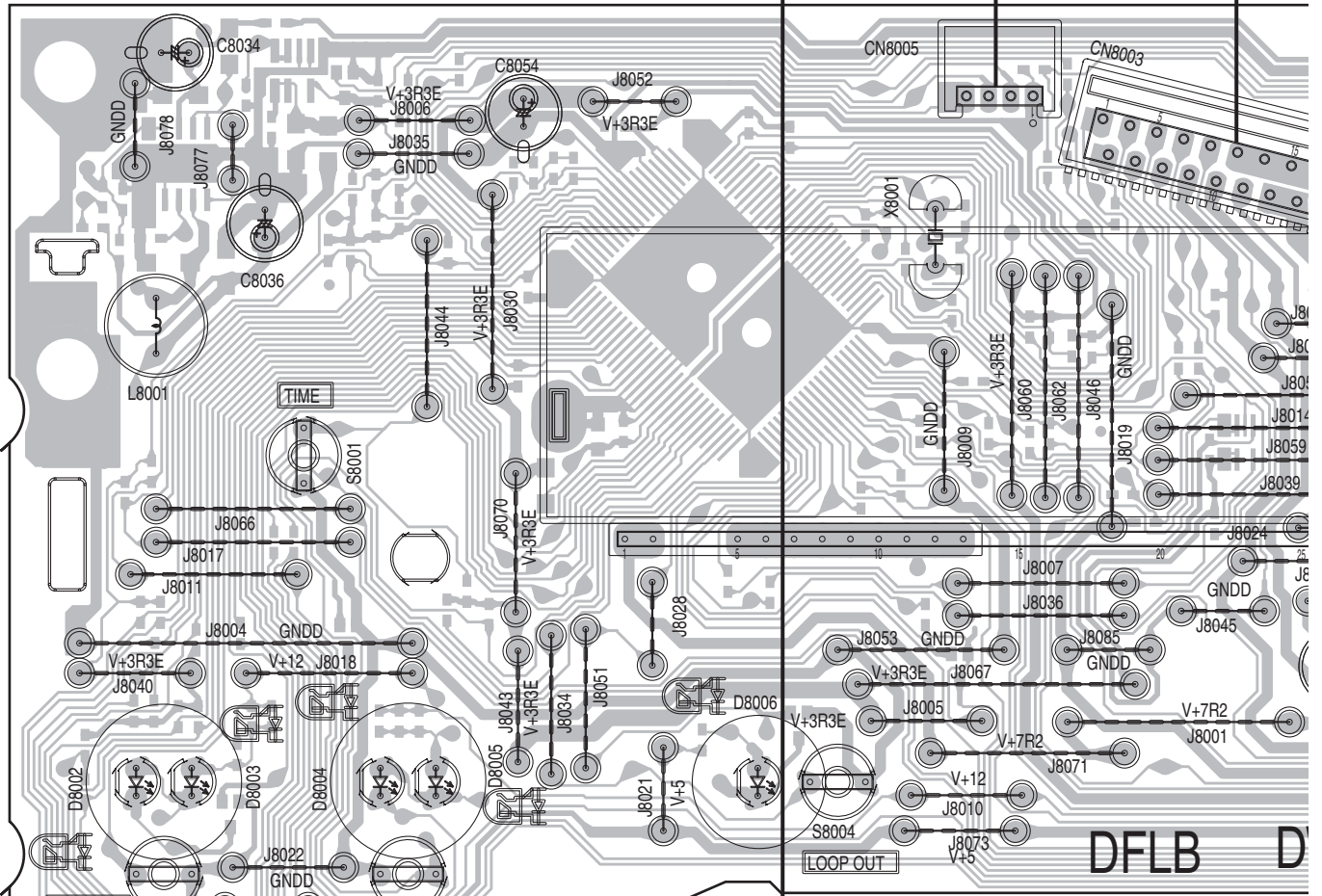

DFLB

G ENCB ASSY

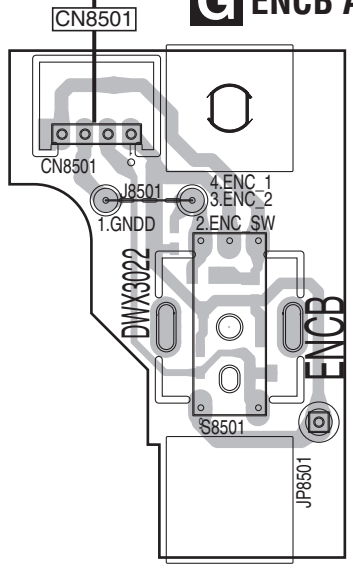

(DNP2493-C)

H CN9201

F **G**

SIDE A

A
B
C
D
E
F

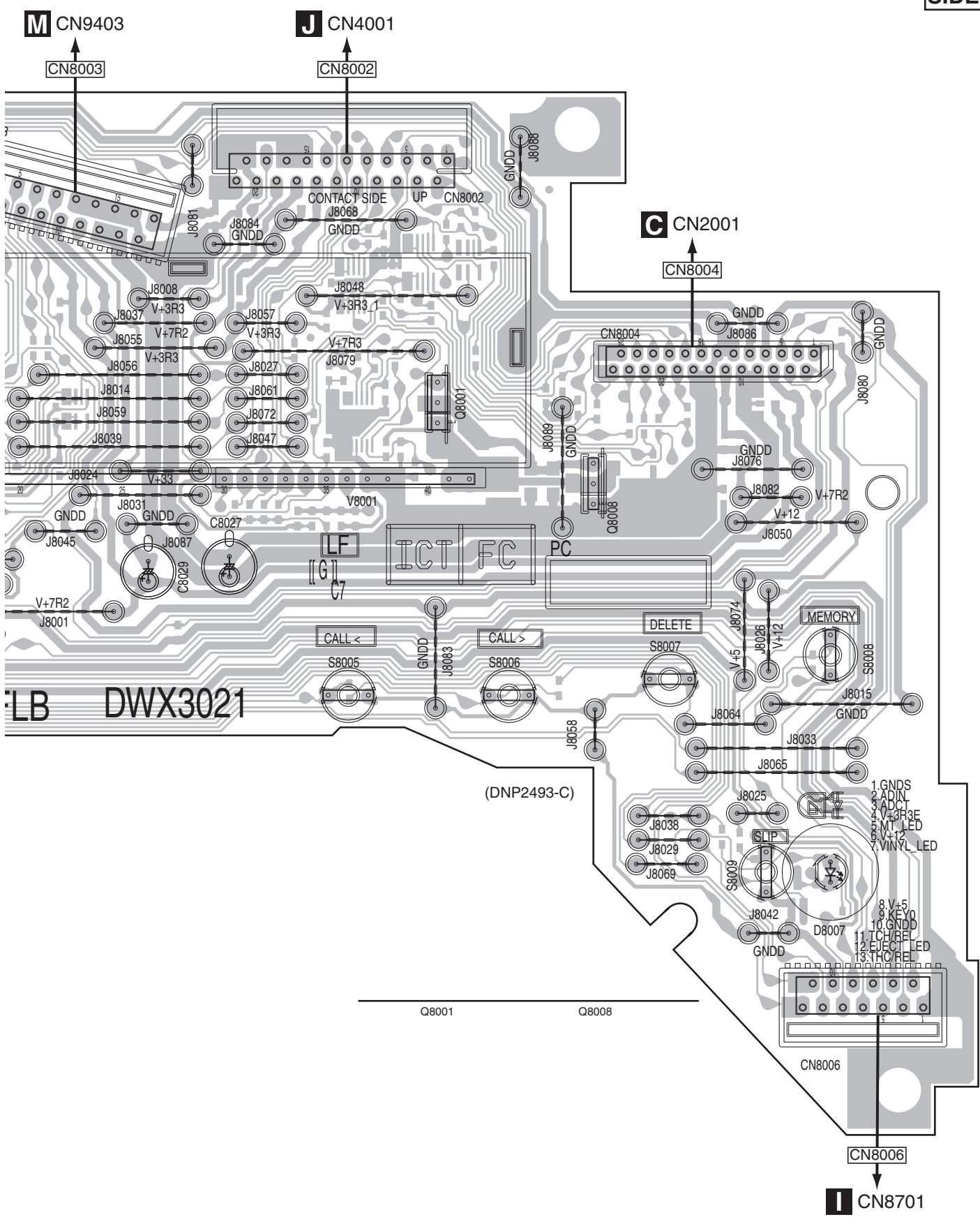

F DFLB ASSY

CN8002

CN8003

CN8004

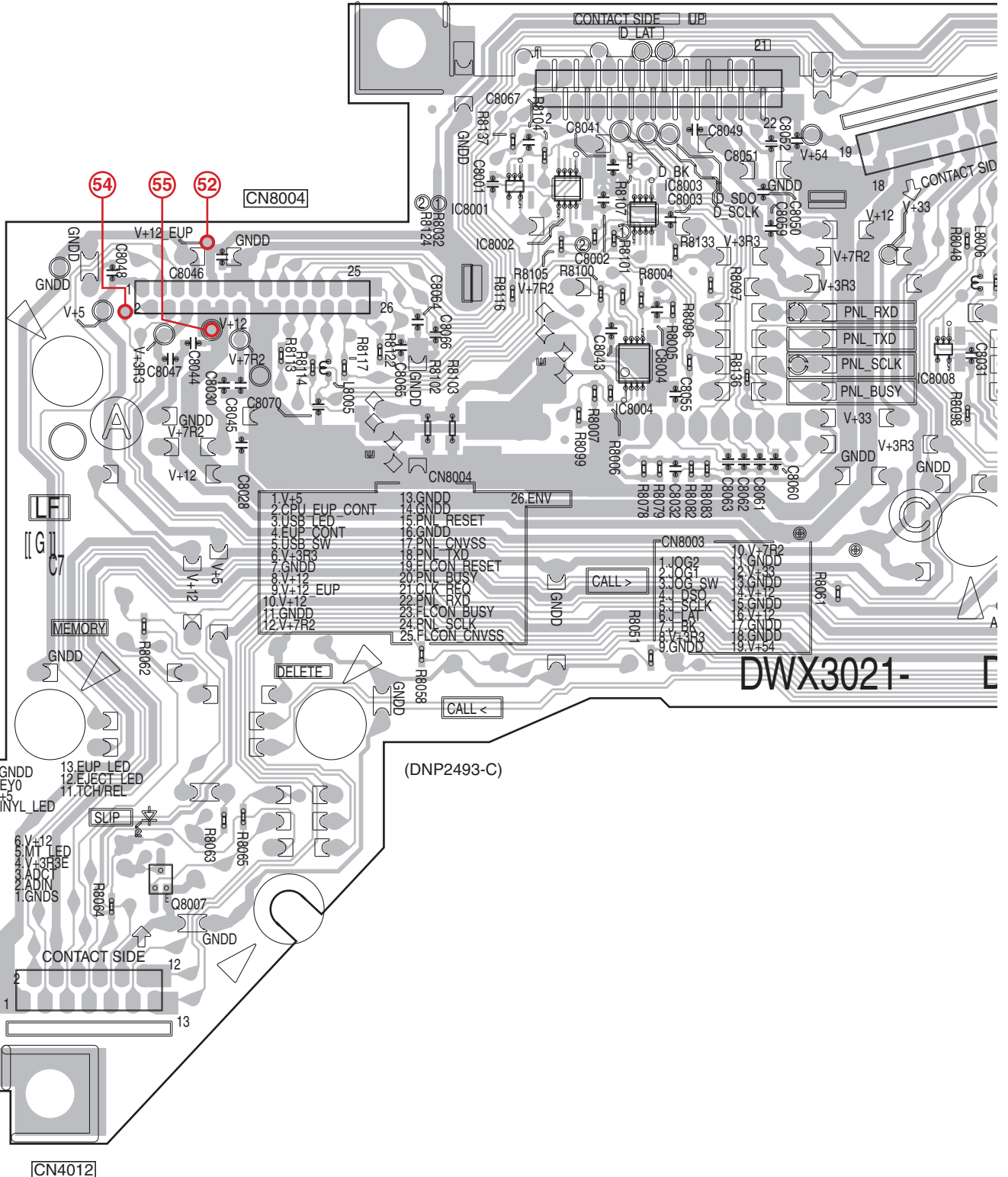

NOTE: The encircled numbers denote measuring point.

11.5 KSWB and SLDB ASSYS

SIDE A

H KSWB ASSY

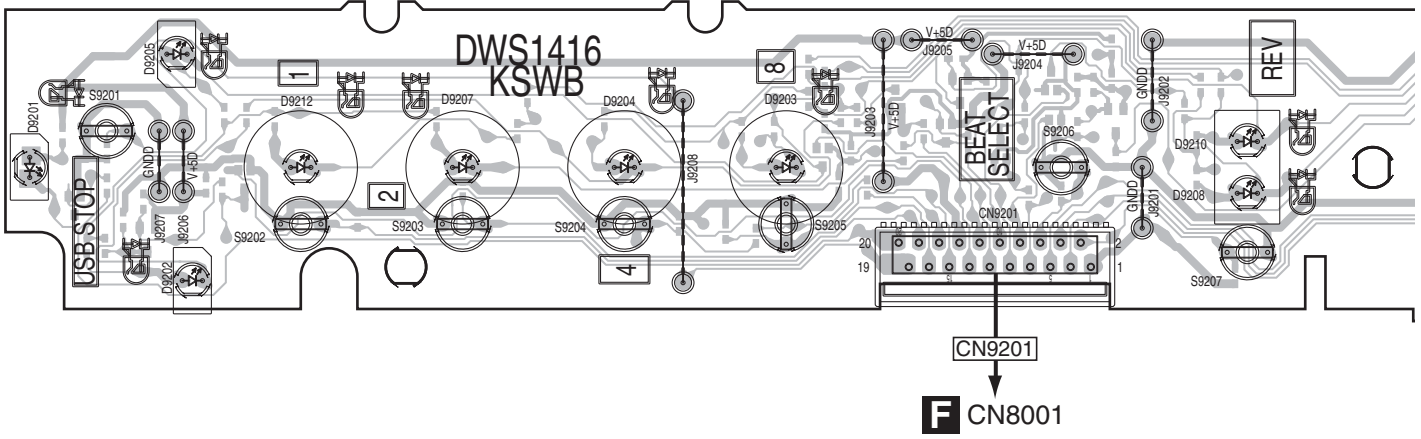

I SLDB ASSY

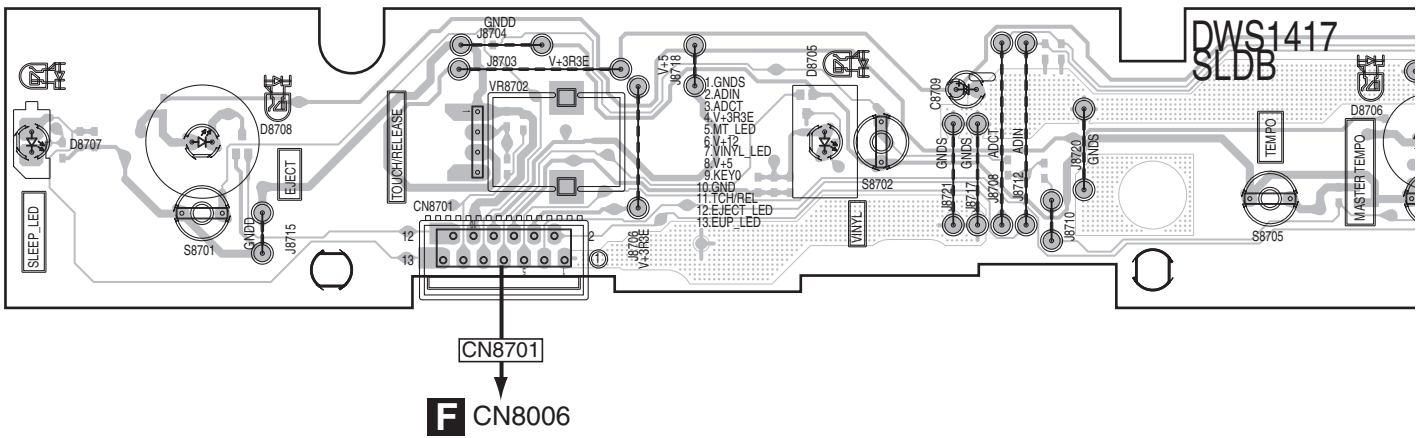

SIDE A

A

B

C

D

E

F

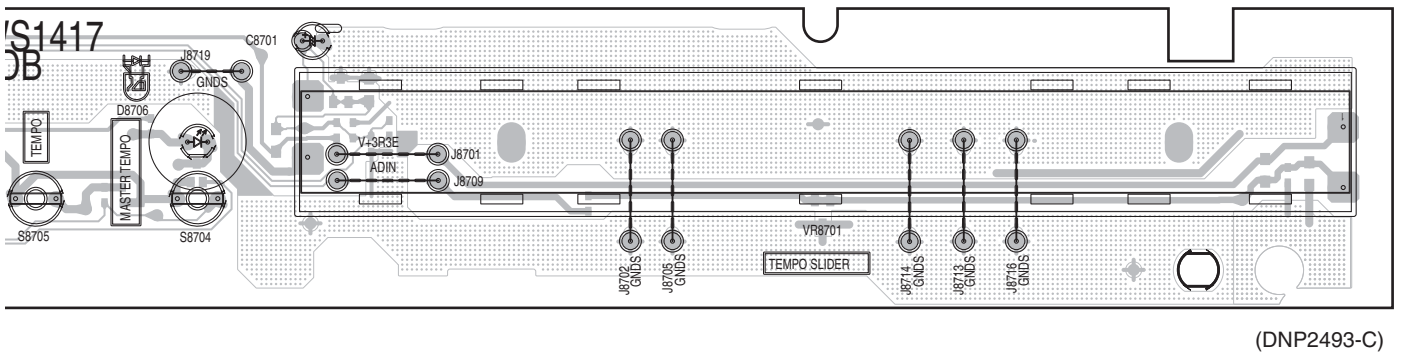
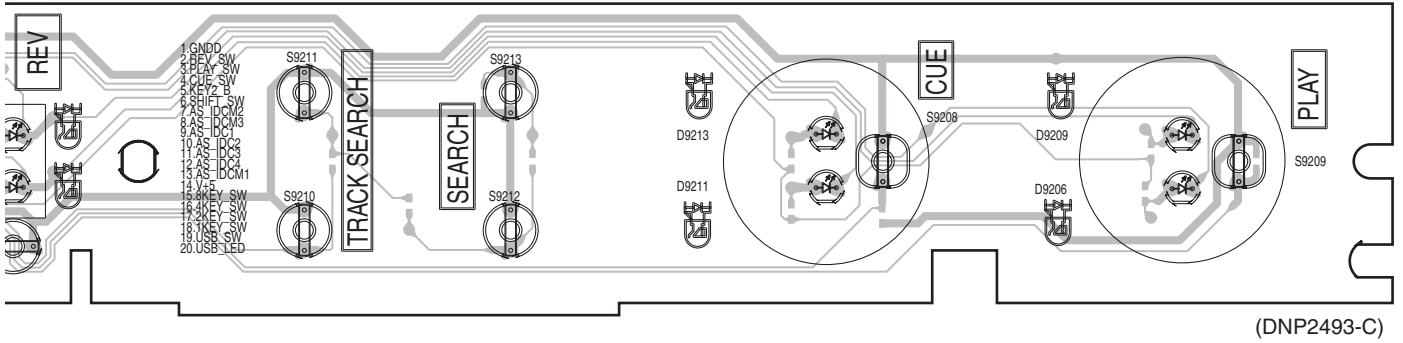

SIDE B

A

KSQB ASSY

B

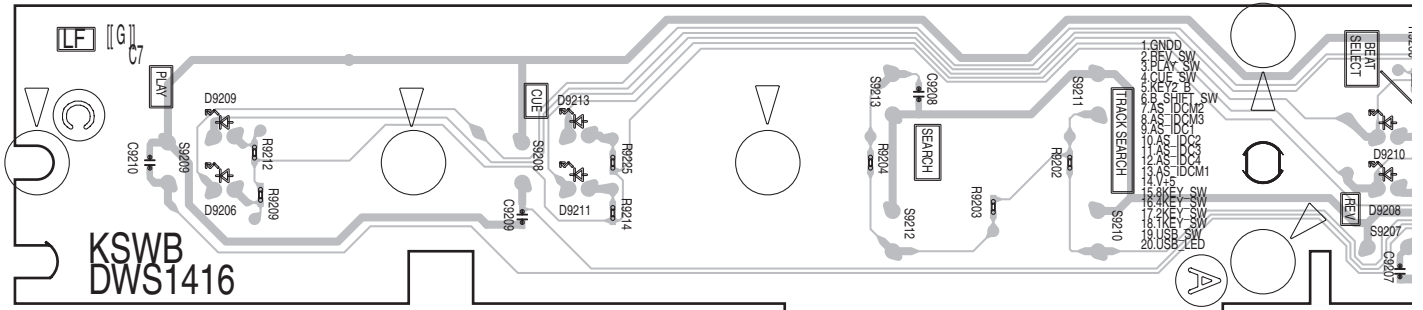

C

D

SLDB ASSY

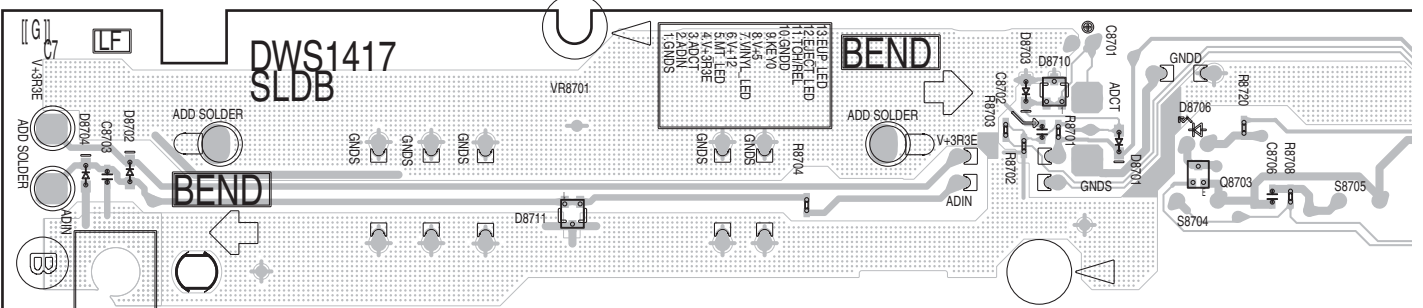

E

Q8703

F



A
B
C
D
E
F

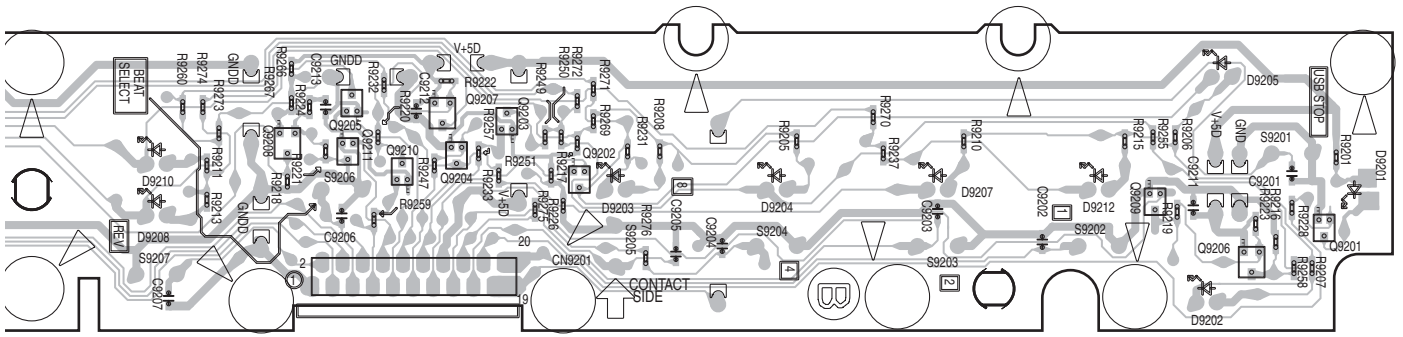

CN9201

(DNP2493-C)

Q9208 Q9205 Q9207 Q9203 Q9202 Q9209 Q9201
 Q9211 Q9210 Q9204 Q9206

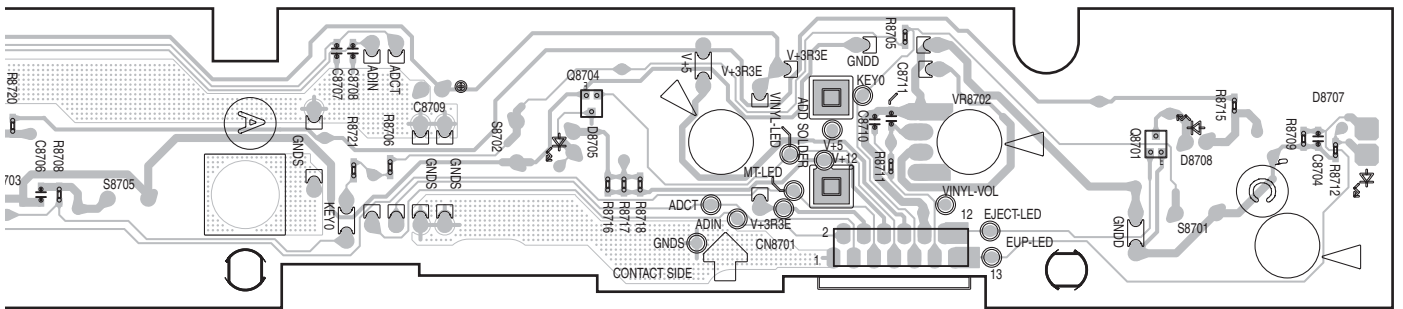

CN8701

(DNP2493-C)

Q8704 Q8701

11.6 BFLB and MSWB ASSYS

SIDE A

J BFLB ASSY

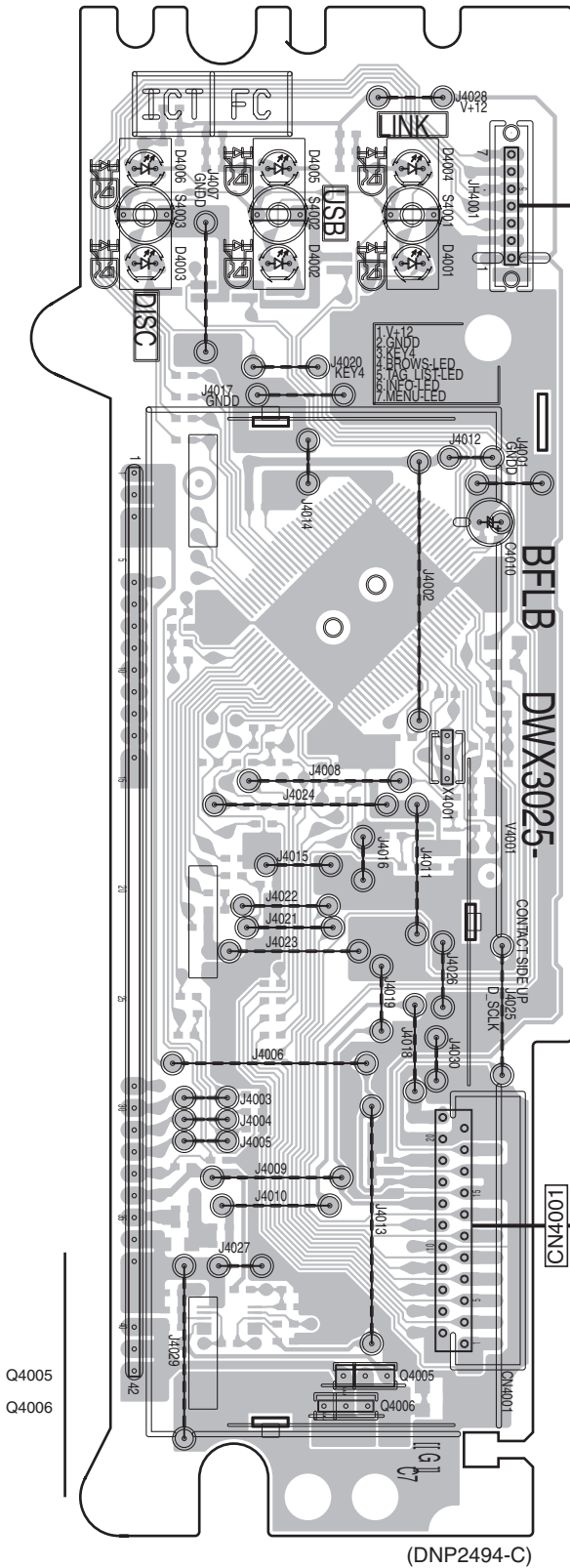

K MSWB ASSY

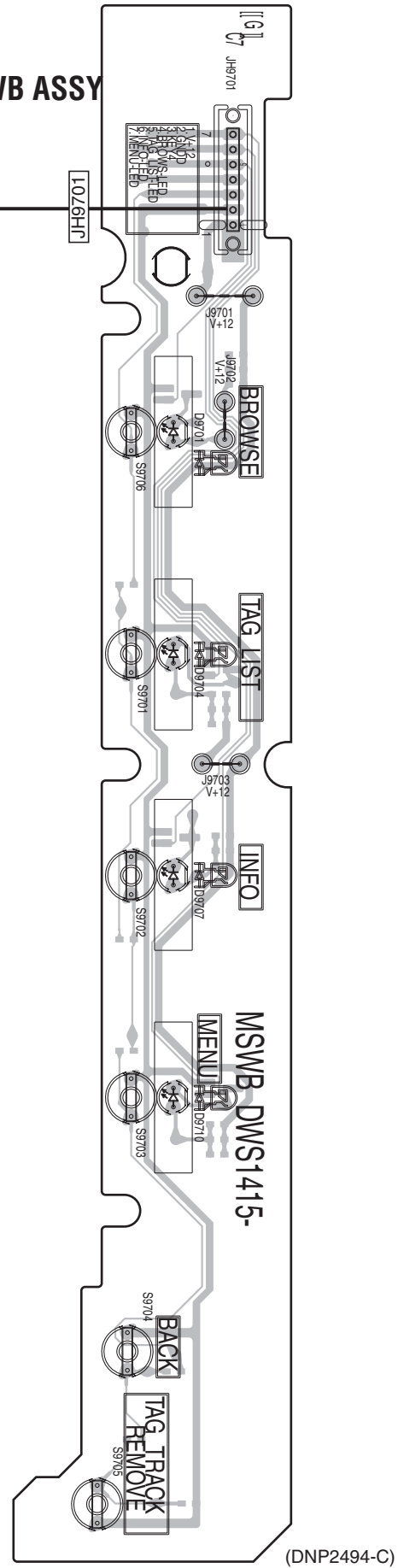

F CN8002

JK

SIDE B

M JFLB ASSY

NOTE: The encircled numbers denote measuring point.

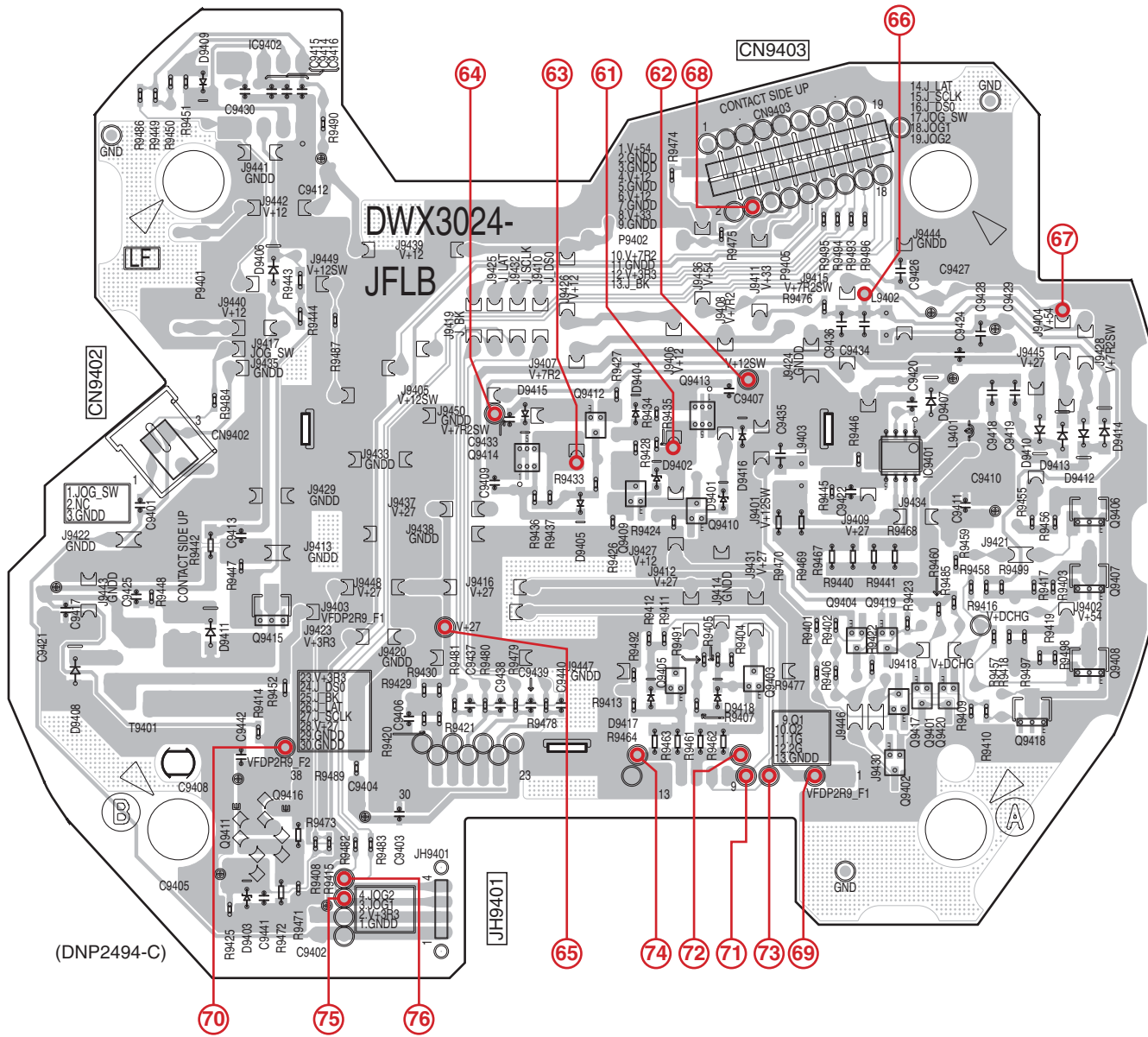

(DNP2494-C)

JH9401

CN9403

DWX3024-
JFLB

CONTACT SIDE UP
CN9403

CN9402

JH9401

VFDP2R9_F1

Q9415

Q9414

Q9412

Q9413

Q9410

Q9409

Q9405

Q9403

Q9404

Q9419

Q9420

Q9406

Q9407

Q9418

Q9408

L JOGB ASSY

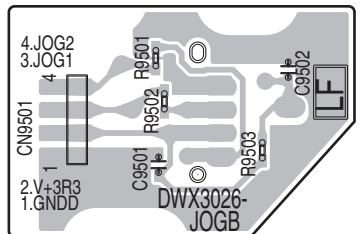

(DNP2494-C)

CDJ-900

LM

11.8 POWER SUPPLY and ACIN ASSYS

SIDE A

N POWER SUPPLY ASSY

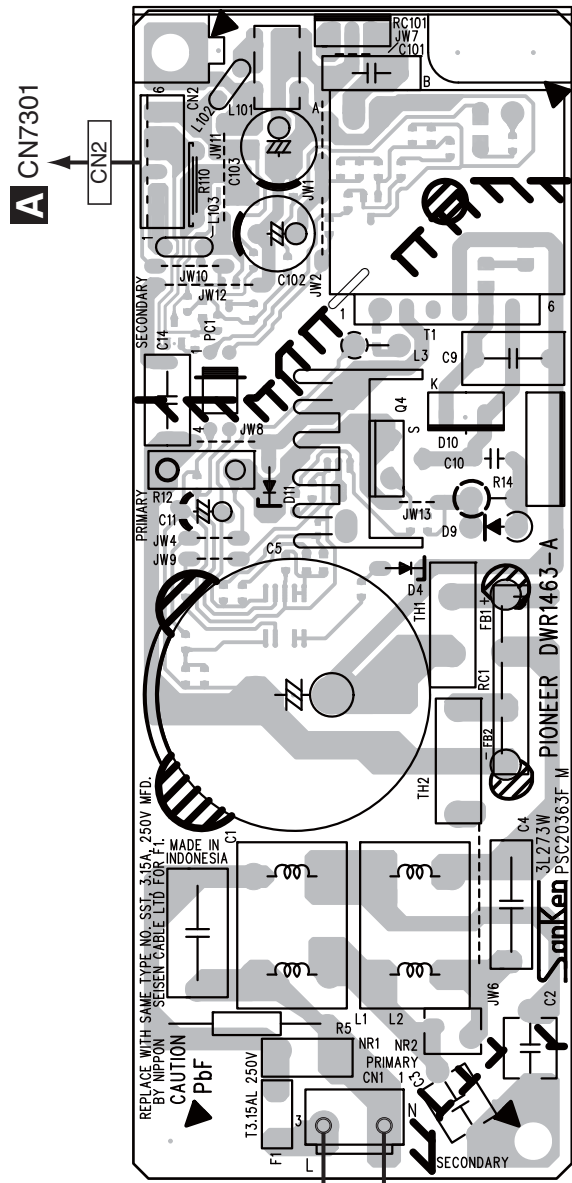

O ACIN ASSY

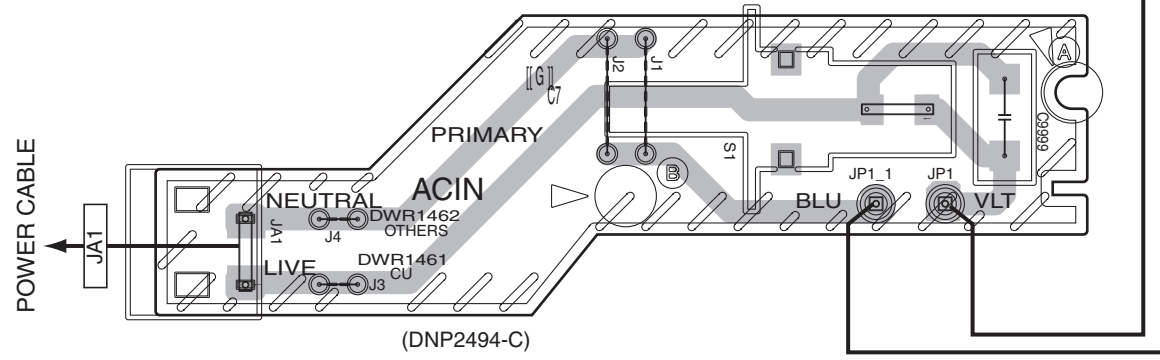

NO

12. PCB PARTS LIST

NOTES: ● Parts marked by "NSP" are generally unavailable because they are not in our Master Spare Parts List.

● The Δ mark found on some component parts indicates the importance of the safety factor of the part. Therefore, when replacing, be sure to use parts of identical designation.

● When ordering resistors, first convert resistance values into code form as shown in the following examples.

Ex.1 When there are 2 effective digits (any digit apart from 0), such as 560 ohm and 47 k ohm (tolerance is shown by J = 5%, and K = 10%).

560 Ω \rightarrow 56 $\times 10^1$ \rightarrow 561.....RD1/APU $\begin{matrix} \boxed{5} & \boxed{6} & \boxed{7} & J \end{matrix}$

47 k Ω \rightarrow 47 $\times 10^3$ \rightarrow 473.....RD1/APU $\begin{matrix} \boxed{4} & \boxed{7} & \boxed{3} & J \end{matrix}$

0.5 Ω \rightarrow R50.....RN2H $\begin{matrix} \boxed{R} & \boxed{5} & \boxed{0} & K \end{matrix}$

1 Ω \rightarrow 1R0.....RSIP $\begin{matrix} \boxed{1} & \boxed{R} & \boxed{0} & K \end{matrix}$

Ex.2 When there are 3 effective digits (such as in high precision metal film resistors).

5.62 k Ω \rightarrow 562 $\times 10^1$ \rightarrow 5621.....RN1/4PC $\begin{matrix} \boxed{5} & \boxed{6} & \boxed{2} & \boxed{1} & F \end{matrix}$

● Meaning of the figures and others in the parentheses in the parts list.

Example) IC 301 is on the point (face A, 91 of x-axis, and 111 of y-axis) of the corresponding PC board.

IC 301 (A, 91, 111) IC NJM2068V

Mark No.	Description	Part No.	Mark No.	Description	Part No.
----------	-------------	----------	----------	-------------	----------

LIST OF ASSEMBLIES

NSP	1..DFLA ASSY	DWM2361
	2..KSWB ASSY	DWS1416
	2..SLDB ASSY	DWS1417
	2..SLMB ASSY	DWS1418
	2..DFLB ASSY	DWX3021

C	2..ENCB ASSY	DWX3022
	2..JACB ASSY	DWX3023

NSP	1..JFLA ASSY (CUXJ)	DWM2362
NSP	1..JFLA ASSY (SYXJ8, FLXJ, KXJ5, AXJ5)	DWM2356
	2..ACIN ASSY (CUXJ)	DWR1461
	2..ACIN ASSY (SYXJ8, FLXJ, KXJ5, AXJ5)	DWR1462
	2..MSWB ASSY	DWS1415

	2..JFLB ASSY	DWX3024
	2..BFLB ASSY	DWX3025
	2..JOGB ASSY	DWX3026

D	1..MAIN ASSY	DWX3019
---	--------------	---------

	1..SRV ASSY	DWX3020
--	-------------	---------

	1..USBA ASSY	DWX3044
--	--------------	---------

Δ	1..POWER SUPPLY ASSY	DWR1463
----------	----------------------	---------

Mark No.	Description	Part No.
----------	-------------	----------

A SRV ASSY SEMICONDUCTORS

	IC 7002	BD7956FS
Δ	IC 7003	BA00DD0WHFP
	IC 7004	AN22022A
Δ	IC 7005	MM1478DFBE
	IC 7006	DYW1776
Δ	IC 7007	PQ1LAX95MSPQ
	IC 7008	MN103S71F
Δ	IC 7301-7303	SI-8005Q
	Q 7002	2SA1036K(PQR)
	Q 7003	HN1B04FU

Q	7005,7006	RT1N144M
D	7301,7302	EP05Q06

D	7306-7308	CMS03
D	7311	RB060L-40

MISCELLANEOUS

L	7005-7007,7310-7325	INDUCTOR	CTF1378
L	7008,7009	INDUCTOR	CTF1745
L	7301-7303	INDUCTOR	CTH1253
L	7304,7305,7307-7309	INDUCTOR	CTF1579
KN	7002	EARTH METAL FITTING	VNF1109

X	7001	CERAMIC RESONATOR	DSS1157
CN	7001	24P FFC CONNECTOR	DKN1445
CN	7002	4P CONNECTOR	DKN1288
CN	7003	CONNECTOR	DKN1312
CN	7004	CONNECTOR	AKM1291

CN	7005	40P CONNECTOR	VKN1818
CN	7301	XH CONNECTOR (6P)	DKN1599
CN	7302	CONNECTOR	AKM1299
Δ	P 7302	PROTECTOR (0.375 A)	DEK1119
Δ	P 7307,7310	PROTECTOR (1.250 A)	DEK1123

RESISTORS

R	7004	RS1/4SA120J
R	7007,7012,7013,7016	RS1/4SA1R0J
R	7027,7028	RS1/4SA3R3J
R	7030,7041,7046,7080	RS1/10SR1002F
R	7039	RS1/10SR3301F

R	7048,7049	RS1/10SR3302F
R	7079	RS1/10SR2700F
R	7118	RS1/10SR1502F
R	7126	RS1/10SR1801F
R	7306-7308	RST1/2SP120J

R	7310	RS1/10SR6802D
R	7311	RS1/10SR3301D
R	7312	RS1/10SR5101D
R	7313	RS1/10SR3902D
R	7314	RS1/10SR5601D

R	7315,7318	RS1/10SR4701D
R	7316	RS1/10SR2402D
R	7317	RS1/10SR2701D
R	7321	RS1/10SR1002D
	Other Resistors	RS1/10SR###J

CAPACITORS

C	7001-7007,7030,7078	CKSRBY103K50
C	7008,7019,7024-7026	CKSRBY104K16

Mark	No.	Description	Part No.	Mark	No.	Description	Part No.
	C 7015		CKSRYPB474K10		IC 108,109,505		K4S561632J-UC75
	C 7018,7041,7071		CEHVVW470M6R3	NSP	IC 114		DYW1775
	C 7022,7361-7376		CCSRCH470J50		IC 115,124		TC7WHU04FU
	C 7023		DCH1275		IC 119		TC74LCX32FTS1
	C 7027,7060,7079,7085		CKSRYPB105K10		IC 120		TC7SH04FUS1
	C 7028,7034,7066,7348		CEHVVW470M16		IC 122		TC7W08FU
	C 7029		DCH1200		IC 123		TC74VHC08FTS1
	C 7031,7035-7038,7043		CKSRYPB104K16		IC 501		D710E001BZDHA275
	C 7032		CEHVAW470M16		IC 507		TC7WU04FU
	C 7033,7062		CKSRYPB473K50		IC 1101		M66291GP
	C 7039,7042,7310-7312		CCSRCH102J50		IC 1102		BD2051AFJ
	C 7040,7047		CCSRCH221J50		IC 1304		RTL8201CP-LF
	C 7044,7099,7113		CCSRCH101J50	⚠	IC 3002		SI-8005Q
	C 7046,7052-7059,7065		CKSRYPB104K16		IC 3003		WM8728SEDS
	C 7048,7339-7341		CKSRYPB224K16		Q 506		2SC2412K
	C 7049		CCSRCH151J50		Q 509,510		2SC4081
	C 7051,7089,7097,7098		CKSRYPB102K50		Q 511,512,1312		LTC124EUB
	C 7061		CCH1426		Q 1301		UM6K1N
	C 7063,7100		CKSRYPB273K25		Q 1302,1308		2SB1698
	C 7064		CKSRYPB561K50		Q 1303		2SD2662
	C 7067,7068,7072-7077		CKSRYPB104K16		Q 1304,1309		IMX2
	C 7080,7091,7107		CKSRYPB103K50		Q 1305		IMT2A
	C 7081,7082,7090,7092		CKSRYPB104K16		Q 1306,1307,1313,1314		DTC143EUA
	C 7083,7084		CKSRYPB471K50		Q 1310		2SD2114K
	C 7086,7088		CKSRYPB182K50		Q 1311,1315,3002		LTA124EUB
	C 7087,7313,7314,7377		CKSRYPB222K50		Q 1316,1317		DTC143EUA
	C 7093		CKSRYPB122K50		Q 3001		RTQ040P02
	C 7094,7096,7101,7103		CKSRYPB104K16		D 3001		UDZS5R6(B)
	C 7095,7106		CKSRYPB105K10		D 3006		RB060L-40
	C 7102,7105,7315		CKSRYPB102K50		D 3007,3008		UDZS10(B)
	C 7104,7108-7110,7112		CKSRYPB104K16		D 3009,3014		UDZS6R2(B)
	C 7111		CKSRYPB333K16		D 3010,3012,3013,3017		1SS352
	C 7301-7303,7335		CKSRYPB104K25		D 3016		UDZS5R1(B)
	C 7304-7309,7327-7329		CCG1221	MISCELLANEOUS			
	C 7316-7318		CKSRYPB103K50	L	101,102 INDUCTOR		CTF1745
	C 7319,7320		CKSRYPB105K16	L	500,501 CHIP SOLID INDUCTOR		XTL3010
	C 7324		CCSRCH122J50	L	1103 INDUCTOR		CTF1579
	C 7325		CCSRCH152J50	L	3002 POWER INDUCTOR		DTH1205
	C 7326		CCSRCH222J50	L	3003,3004 INDUCTOR		CTF1545
	C 7342-7344		CCH1565	F	101,108,1101,1103 EMI FILTER		CCG1160
	C 7347,7351		CKSRYPB104K16	F	1102 FILTER		CTF1701
	C 7350,7354		CEHVVW470M16	F	1302,1303 EMI FILTER		DTL1106
	C 7355,7357,7358		ACG1142	F	1305 EMI FILTER		CCG1160
	C 7359		CCG1192	JA	1101 USB CONNECTOR B		DKN1574
	C 7360		CKSQYB106K6R3	JA	1301 RJ45 MODULAR JACK		DKN1576
	C 7378		CKSRYPB222K50	X	104 RESONATOR		CSS1753
				X	105 CRYSTAL (26.965 MHz)		DSS1185
				X	503 RESONATOR		CSS1620
				X	1302 CRYSTAL (25 MHz)		VSS1215
				CN	501 CONNECTOR		VKN1938
				CN	1303 CONNECTOR		CKS5075
				CN	1305 CONNECTOR		AKM1276
				CN	2001 26P CONNECTOR		VKN1430
				CN	3001 CONNECTOR		AKM1284
				NSP	0 ID LABEL ASSY		AXW7015
				⚠	P 2 PROTECTOR (0.500 A)		DEK1120
				⚠	P 3 PROTECTOR (1.250 A)		DEK1123
				RESISTORS			
				R	108		RS1/16SS5101F

B SLMB ASSY

MISCELLANEOUS

S 8901,8902 PUSH SWITCH
CN8901 PLUG (5P)

C MAIN ASSY

SEMICONDUCTORS

IC 101
IC 102

R5S77641N300BG
BD45302G

RESISTORS

R 108

RS1/16SS5101F

Mark	No.	Description	Part No.
	R	325,3105,3109	RS1/10SR0R0J
	R	739-742	RAB4CQ101J
	R	1350-1353	RS1/16SS49R9F
	R	1376	RS1/16SS1101F
	R	1378	RS1/16SS1001F
	R	1392	RAB4CQ220J
	R	3006	RST1/2SP1R0J
	R	3009,3024	RS1/10SR223J
	R	3012	RST1/2SP120J
	R	3015	RS1/16SS6801D
	R	3016	RS1/16SS4300D
	R	3017	RS1/16SS4701D
	R	3028,3029	RS1/4SA270J
	R	3035,3037	RS1/8SQ272J
	R	3036,3038-3040	RS1/8SQ222J
	R	3064	RS1/8SQ101J
	R	3115	RS1/10SR471J
	R	3124	RS1/8SQ560J
		Other Resistors	RS1/16SS###J

Mark	No.	Description	Part No.
	C	3017,3032	CCSRCH102J50
	C	3020	CKSRYPB331K50
	C	3023	CKSRYPB103K50
	C	3026	CKSRYPB224K10
	C	3035,3041,3123-3125	CCG1171
	C	3087,3090	CKSRYPB104K16
	C	3093,3100	CEHVAW101M16
	C	3094,3095	CKSQYB475K16
	C	3096-3099	CKSQYB105K16
	C	3102,3104,3108-3110	CEHVAW470M16
	C	3103,3105-3107	CKSSYPB104K16
	C	3114	CKSSYPB104K10
	C	3120,3130	CCSSCH220J50
	C	3122	CCSSCH471J50
	C	3131,3134,3135	CCSSCH470J50

CAPACITORS

C	101-108,110-112	CKSSYPB104K10
C	109,137,148,204	CCG1171
C	114,116,117,119	CKSSYPB104K10
C	118,120,122,124	CKSSYPB102K50
C	121,123,125	CKSSYPB104K10
C	126,217,220,223	CKSSYPB102K50
C	128-136,138-147	CKSSYPB104K10
C	156,157,159,160	CKSSYPB104K10
C	162-165,167,169	CKSSYPB104K10
C	171-181,183-200	CKSSYPB104K10

C	202,203,214-216	CKSSYPB104K10
C	211,233,234,246	CCG1171
C	218,219,221,222	CKSSYPB104K10
C	224,225,242-245	CKSSYPB104K10
C	226,1345,1356,1359	CKSSYPB102K50
C	228,229	CCSSCH5R0C50
C	230,231,617,618	CCSSCH7R0D50
C	232,235,595,1111	CEHVAW221M6R3
C	247,577,578,597	CCG1171
C	248,501-520,524	CKSSYPB104K10

C	528-547,556,576	CKSSYPB104K10
C	571	CEHVAW470M6R3
C	580,584-589,619	CKSSYPB104K10
C	596,1120,1124,1125	CEHVAW101M6R3
C	1101,1107,1112,1115	CKSSYPB104K10

C	1102,1106,1113,1116	CKSSYPB103K16
C	1105,1108,1127,1385	CCG1171
C	1118,3101	DCH1201
C	1119,1126,1319,1322	CKSSYPB104K10
C	1122,1123	CKSSYPB103K16

C	1128,1129,1358	CKSRYPB105K10
C	1323,1325,1329,1364	CKSSYPB104K10
C	1328	CEHVAW330M10
C	1342,1363	CEHVAW221M6R3
C	1362,3115-3118	CKSSYPB102K50

C	1365,1379	CCSSCH120J50
C	1387	CEHVAW101M6R3
C	3002,3005-3008,3038	CKSRYPB104K16
C	3003,3111-3113	ACG1142
C	3011,3044	ACH1495

D USBA ASSY
MISCELLANEOUS

JA 9901	USB CONNECTOR A	DKB1087
KN9901,9902	WRAPPING TERMINAL	VNF1084
CN9901	L-PLUG (5P)	KM200NA5L
VA 9903	VARISTORS	EZJZ1V270RM

CAPACITORS

C	9901	CEHAR101M6R3
C	9902	CKSRYPB105K10

E JACB ASSY
SEMICONDUCTORS

IC	8801-8803	NJM4580MD
Q	8801-8804	2SD2114K
Q	8805,8809	2SK3320
Q	8807,8810	HN1C01FU
Q	8821,8822	2SC2412K
D	8803,8804	1SS352
D	8805,8808	NNCD6.2MF

MISCELLANEOUS

JA 8801	PIN JACK (2P)	AKB7181
JA 8802	JACK	VKB1243
JA 8803	1P JACK	DKB1089
CN8801	PLUG (12P)	KM200NA12
VA 8800	VARISTORS	EZJZ1V270RM

RESISTORS

R	8808,8809	DCN1191
R	8810,8811,8820-8823	DCN1186
R	8813,8815	DCN1192
R	8826,8828,8846,8847	DCN1189
R	8832,8849	DCN1190

R	8834,8835,8851,8852	DCN1187
R	8836,8838,8853,8854	DCN1188
R	8839-8844,8855,8856	DCN1186
R	8867,8876-8879,8881	RS1/8SQ0R0J
R	8888	RS1/8SQ0R0J

Other Resistors RS1/10SR###J

CAPACITORS

C	8805,8806	CCH1357
---	-----------	---------

Mark	No.	Description	Part No.
C	8807,8809,8852,8854		CKSRYB103K50
C	8808,8845-8849,8851		CKSRYB104K50
C	8810,8811		CFHBSQ471J50
C	8814,8827		CKSRYB223K50
C	8816,8817,8828,8829		DCG1056
C	8821-8824,8832-8835		DCG1062
C	8840,8842		DCH1282
C	8841,8843,8844,8850		DCH1320
C	8856		CKSRYB104K50

F DFLB ASSY SEMICONDUCTORS

IC	8001	TC7SH04FUS1
IC	8002	TC7WH32FU
IC	8003	TC7WH08FU
IC	8004	NJM14558V
IC	8005	M3030RFCPPF
IC	8007	BD45302G
IC	8008	TC7SH02FUS1
△	IC 8010	NJM2392M
Q	8001	2SB1237X
Q	8002-8005,8007	LTC124EUB
Q	8006	LTA124EUB
Q	8008	2SD1858X
D	8002-8006	SLI-343Y8C(KLMN)
D	8007	SLI-343U8RC(HJKL)
D	8008	EP05Q06

MISCELLANEOUS

L	8001	RADIAL LEAD INDUCTOR	DTH1206
L	8002,8003	INDUCTOR	CTF1579
L	8005,8006	INDUCTOR	CTF1378
V	8001	VFD	DEL1065
S	8001,8005-8009	SWITCH	VSG1024
S	8002-8004	TACT SWITCH	DSG1079
X	8001	CRYSTAL RESONATOR	DSS1166
CN	8001	CONNECTOR	9607S-20F
CN	8002	CONNECTOR	XKP3022
CN	8003	CONNECTOR 19P	52492-1920
CN	8004	26P CONNECTOR	VKN1257
CN	8005	L-PLUG (4P)	KM200NA4L
CN	8006	CONNECTOR 13P	52492-1320
O		FL HOLDER D	DNH2883

RESISTORS

R	8004,8005	RS1/10SR4702D
R	8006	RS1/10SR4701D
R	8007,8099	RS1/10SR1802D
R	8091	RS1/4SA2R7J
R	8092	RS1/10SR3301D
R	8093	RS1/10SR3302D
R	8094	RS1/10SR2202D
R	8102,8103	RS1/4SA120J
	Other Resistors	RS1/10SR###J

CAPACITORS

C	8001-8003,8006,8023	CKSRYB104K16
C	8004,8007-8012,8015	CCSRCH102J50
C	8013	CKSRYB474K10
C	8016,8044-8051,8059	CCSRCH102J50
C	8020,8022	CCSRCH100D50

Mark	No.	Description	Part No.
C	8024,8026,8028		CKSRYB104K16
C	8025		CKSRYB103K50
C	8027,8029,8034		CEHAS470M16
C	8030-8032,8043,8055		CKSRYB104K16
C	8033		CCSRCH560J50
C	8035		CKSYB106K16
C	8036,8054		CEHAS101M10
C	8038,8039		BCG1054
C	8041,8062,8063,8067		CCSRCH220J50
C	8042		CCSRCH221J50
C	8052		ACG7050
C	8053		CKSQYB106K6R3
C	8064		CCSRCH102J50
C	8068		CCSRCH470J50
C	8070		CCSRCH220J50

G ENCB ASSY MISCELLANEOUS

S	8501	ENCODER SW	DSX1080
CN	8501	L-PLUG (4P)	KM200NA4L

CAPACITORS

C	8501,8502	CKSRYB103K50
---	-----------	--------------

H KSWB ASSY SEMICONDUCTORS

Q	9201	DTC143EUA
Q	9202-9205,9209-9211	LTC124EUB
Q	9206-9208	2SA1162
D	9201,9208,9210	SLI-343U8RC(HJKL)
D	9202-9205,9207	SLI-343Y8C(KLMN)
D	9206,9209	SLI-343M8C(FGHJ)
D	9211-9213	SLI-343Y8C(KLMN)

MISCELLANEOUS

S	9201,9210-9213	SWITCH	VSG1024
S	9202-9207	TACT SWITCH	DSG1079
S	9208,9209	TACT SWITCH	DSG1117
CN	9201	CONNECTOR 20P	52492-2020

RESISTORS

	All Resistors	RS1/10SR###J
--	---------------	--------------

CAPACITORS

C	9211-9213	CKSRYB104K16
---	-----------	--------------

I SLDB ASSY SEMICONDUCTORS

Q	8701,8703,8704	LTC124EUB
D	8701-8704	1SS352
D	8705	SLR343BC4T(JKLM)
D	8706,8707	SLI-343U8RC(HJKL)
D	8708	SLI-343M8C(FGHJ)

MISCELLANEOUS

VR	8701	VR	DCV1009
VR	8702	POTENTIOMETER	DCS1062

Mark	No.	Description	Part No.
S	8701,8702,8704,8705	SWITCH	VSG1024
CN	8701	CONNECTOR 13P	52492-1320

Mark	No.	Description	Part No.
------	-----	-------------	----------

RESISTORS

All Resistors

RS1/10SR###J

CAPACITORS

C 8702,8703
C 8704

CKSRYB102K50
CKSRYB103K50

J BFLB ASSY

SEMICONDUCTORS

IC 4001
IC 4002
IC 4003
Q 4002-4004
Q 4005

Q 4006
D 4001,4004
D 4002,4003,4005,4006

TC7SH08FUS1
R5F363AENFA-UO
NJM14558V
LTC124EUB
2SB1237X

2SD1858X
SLR343BC4T(JKLM)
SLI-343M8C(FGHJ)

MISCELLANEOUS

L 4001 INDUCTOR
L 4003,4004 INDUCTOR
V 4001 VFD
S 4001-4003 SWITCH
X 4001 CERAMIC RESONATOR

CN4001 CONNECTOR
O FL HOLDER B
JH 4001 7P CABLE HOLDER

CTF1579
CTF1378
DEL1066
VSG1024
DSS1183

XKP3022
DNH2921
51048-0700

RESISTORS

R 4053,4054
R 4055
R 4056,4057
R 4060,4061
Other Resistors

RS1/10SR4702D
RS1/10SR4701D
RS1/10SR1802D
RS1/4SA100J
RS1/10SR###J

CAPACITORS

C 4001,4002,4005,4006
C 4008,4009,4020
C 4010
C 4011
C 4012,4013

C 4014-4017,4021-4026
C 4018
C 4019

CKSRYB104K16
CKSRYB104K16
CEHAS470M6R3
CCSRCH102J50
CCSRCH470J50

CCSRCH220J50
CKSQYB106K6R3
CKSYB104K2A

K MSWB ASSY

SEMICONDUCTORS

Q 9701-9704
D 9701,9704,9707,9710

LTC124EUB
SLI-343M8C(FGHJ)

MISCELLANEOUS

S 9701-9706 SWITCH

VSG1024

RESISTORS

All Resistors

RS1/10SR###J

MISCELLANEOUS

JH 9701 7P CABLE HOLDER

51048-0700

L JOGB ASSY

MISCELLANEOUS

CN 9501 4PJUMPER CONNECTOR

52151-0410

RESISTORS

All Resistors

RS1/10SR###J

MISCELLANEOUS

PC 9501 PHOTO INTERRUPTER

SEDS-7573

CAPACITORS

C 9501,9502

CKSRYB103K50

M JFLB ASSY

SEMICONDUCTORS

⚠ IC 9401
⚠ IC 9402
Q 9401,9402,9409,9410
Q 9403,9405
Q 9404,9419

NJM2392M
TLC555IP
DTC143EUA
2SC4081
2SA1576A

Q 9406-9408
Q 9411
Q 9412,9417,9420
Q 9413,9414
Q 9415

2SD1767
2SB1237X
DTC143EUA
RTQ040P02
RHP020N06

Q 9416
Q 9418
D 9401
D 9402,9403
D 9404,9405,9409,9417

2SD1858X
2SD2662
UDZS4R3(B)
UDZS6R8(B)
1SS352

D 9406-9408,9410-9414
D 9418

RB160M-60
1SS352

MISCELLANEOUS

L 9401 POWER INDUCTOR
L 9402,9403 INDUCTOR
V 9401 FL INDICATOR TUBE
T 9401 POWER TRANSFORMER
CN 9402 CONNECTOR

DTL1198
CTF1579
DEL1058
DTT1232
CKS1072

CN 9403 CONNECTOR
O FL HOLDER
JH 9401 4P CABLE HOLDER
P 9401,9405 PROTECTOR (500 mA)
P 9402 PROTECTOR (1.5 A)

XKP3019
DNF1735
51048-0400
AEK7060
AEK7065

RESISTORS

R 9416-9419
R 9440,9441,9467,9468
R 9442
R 9443
R 9444

DCN1184
RS1/4SA271J
RST1/2SP1R0J
RS1/8SQ102J
RS1/8SQ101J

R 9445
R 9446
R 9449
R 9450
R 9451

RS1/10SR3302F
RS1/10SR1601F
RN1/16SE2201D
RN1/16SE1502D
RN1/16SE6802D

R 9452

RS1/8SQ223J

Mark	No.	Description	Part No.
R	9455,9456		DCN1183
R	9461-9464		RS1/4SA470J
R	9469,9470		RS1/4SAR43J
R	9472,9473		RS1/4SA390J
	Other Resistors		RS1/10SR###J

CAPACITORS

C	9401		CKSRYPB223K16
C	9402,9404		CEHAR101M10
C	9403,9406,9409,9411		CKSRYPB104K50
C	9407		CKSRYPB473K50
C	9410		CEHAR220M16
C	9413,9416,9424,9425		CKSRYPB104K50
C	9414,9420,9438-9440		CCSRCH101J50
C	9417		CKSRYPB105K16
C	9418,9419,9428		CCG1255
C	9421		CEAT101M16
C	9422		CKSRYPB221K50
C	9423		CEHAT101M35
C	9426		ACG7065
C	9427		CEHAT100M63
C	9429		CEHAR100M50
C	9430,9433,9441		CKSRYPB104K50
C	9434,9436		ACG1147
C	9435		CKSYB106K16
C	9437		CCSRCH470J50
C	9442		CKSQYB475K16

N POWER SUPPLY ASSY

There is no service parts.

O ACIN ASSY (DWR1461)

MISCELLANEOUS

△	JA 1	AC INLET 1P	XKP3085
△	S 1	SWITCH	DSA1035
△	JP 1	CONNECTOR ASSY 2P	DKP3822

CAPACITORS

△	C 9999		ACG7033
---	--------	--	---------

O ACIN ASSY (DWR1462)

MISCELLANEOUS

△	JA 1	AC INLET 1P	XKP3084
△	S 1	SWITCH	DSA1035
△	JP 1	CONNECTOR ASSY 2P	DKP3822

CAPACITORS

△	C 9999		ACG7033
---	--------	--	---------