

CASSETTE TAPE DECK

CT-300

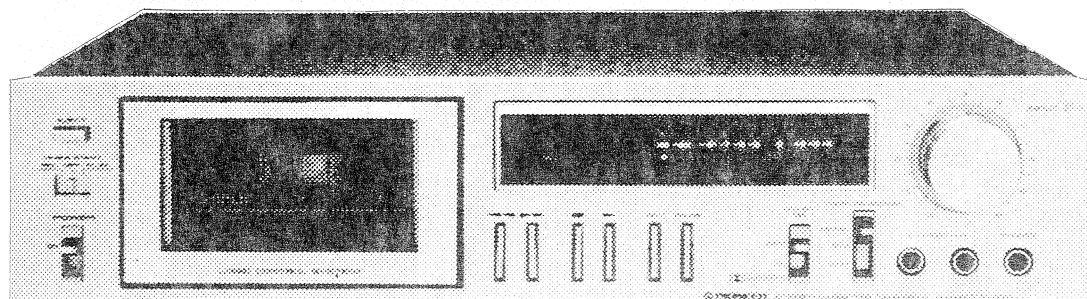

MODEL CT-300 COMES IN SIX VERSIONS DISTINGUISHED AS FOLLOWS:

Type	Voltage	Remarks
HE	220V and 240V (switchable)	Europe model
HB	220V and 240V (switchable)	U.K. model
HP	220V and 240V (switchable)	Australia model
KU	120V only	U.S.A model
D	120V, 220V and 240V (switchable)	General export model
D/G	120V, 220V and 240V (switchable)	U.S. Military model

- This service manual is applicable to the CT-300/HE, HB and HP types.

CONTENTS

1. SPECIFICATIONS	2	8. ELECTRICAL ADJUSTMENTS	16
2. FRONT PANEL FACILITIES	3	9. SCHEMATIC DIAGRAM	20
3. BLOCK DIAGRAM	5	10. P.C. BOARD CONNECTION DIAGRAM	23
4. LEVEL DIAGRAM	7	11. PARTS LIST	26
5. PARTS LOCATION	8	12. EXPLODED VIEWS	28
6. CIRCUIT DESCRIPTIONS	10	13. PACKING	34
7. MECHANICAL ADJUSTMENTS	14		

 **PIONEER®**

1. SPECIFICATIONS

Systems Compact cassette, 2-channel stereo
Motor DC servo motor x 1
Heads
 . . . "Hard Permalloy" recording/playback head x 1
 "Ferrite" erasing head x 1
Fast Winding Time
 Approximately 100 seconds (C-60 tape)
Wow and Flutter No more than 0.05% (WRMS)
 No more than 0.17% (DIN)

Frequency Response

-20dB recording:

Standard, LH tapes 20 to 15,000Hz
 (30 to 14,000 Hz \pm 3dB)
Chromium dioxide tape 20 to 17,000Hz
 (30 to 16,000Hz \pm 3dB)
Metal tape 20 to 18,000Hz
 (30 to 17,000Hz \pm 3dB)

0dB recording:

Chromium dioxide tape 30 to 8,000Hz \pm 3dB
Metal tape 30 to 12,500Hz \pm 3dB

Signal-to-Noise Ratio

Dolby NR OFF More than 58dB
Dolby NR ON More than 68dB (over 5kHz)

Harmonic Distortion No more than 1.2 % (0dB)

Input

(Sensitivity/Maximum allowable input/Impedance)

MIC (L, R)
 0.3mV/57mV/10k Ω , 6mm diam. jack
 (Reference MIC impedance; 250 Ω to 10k Ω)

LINE (INPUT) 50mV/25V/75k Ω

Output (Reference level/Load impedance)

LINE (OUTPUT) 450mV/50k Ω
Headphones 65mV/8 Ω , 6mm diam. jack

Subfunctions

- Dolby NR system (ON/OFF)
- Stand-by mechanism with unattended recording
- 3 position tape selector (NORM/CrO₂/METAL)
- IC full logic control
- Fluorescent display level meter (-20 to +8dB)
- Air damp eject function
- Full automatic stop mechanism

Miscellaneous

Power Requirements . . . AC 220V/240V (switchable)
 50/60Hz

Power Consumption 19 watts

Dimensions 420(W) x 99(H) x 327(D)mm
 16-9/16(W) x 3-7/8(H) x 12-7/8(D)in

Weight (without package) 4.7 kg (10 lb 6 oz)

Furnished Parts

Operating instructions HB and HP models; 1
 HE model (English, German/French); 2

NOTE:

Specifications and the design subject to possible modifications without notice due to improvements.

NOTES:

1. Reference Tapes: Standard & LH: DIN 45513/BLATT6 or equiv.
 : CrO₂ : DIN45513/BLATT7 (CrO₂) or equiv.
2. Reference Recording Level: Meter 0dB indicating level (160 nwb/m magnetic level = Philips cassette reference level)
3. Reference Signal; 333Hz
4. Wow & Flutter: • JIS [3kHz, with acoustic compensation (weighted), rms value] DIN [3,150Hz, with acoustic compensation (weighted) PEAK value] ; DIN45507
5. Frequency Response: • Measured at -20dB level, DOLBY NR OFF, level deviation is \pm 6dB without indication.
6. Signal to Noise Ratio: • Measured at the third harmonic distortion 3% level, weighted.
7. Sensitivity: Input level (mV) required for reference recording level with input (REC) controls set to maximum.
8. Maximum Allowable Input: While decreasing settings of input (REC) level controls and increasing level at input jacks, this is the maximum input level (mV) at the point where recording amplifier output waveform becomes clipped.
9. Reference Output Level: Playback output level when meter indicates 0dB.
10. This model doesn't employ a recording/playback connector (DIN-type).

2. FRONT PANEL FACILITIES

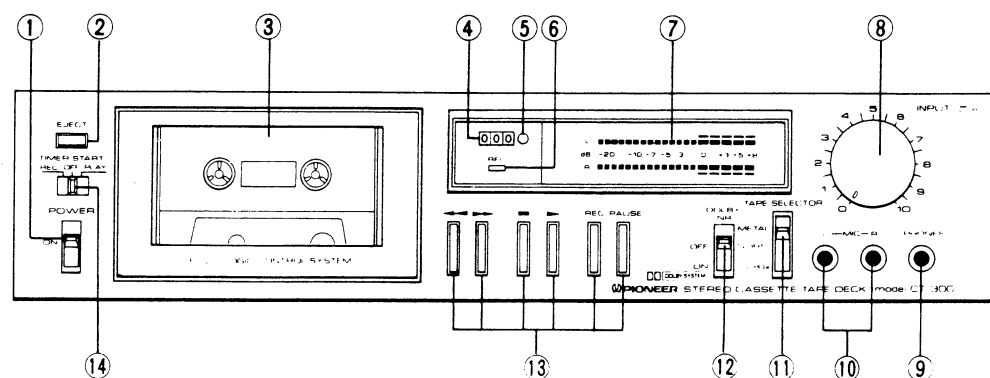

① POWER SWITCH

Set this switch to ON to supply power to the tape deck.

NOTE:

For about 4 seconds after the power has been switched on, the function buttons will not work even when depressed.

② EJECT BUTTON

When this switch is depressed, the cassette holder is jumped out.

③ CASSETTE HOLDER

④ TAPE COUNTER

⑤ COUNTER RESET BUTTON

Use this switch to reset the tape counter to "000".

⑥ REC (RECORDING) INDICATOR

⑦ LEVEL METERS

These indicate the input level during recording and the output level during playback.

⑧ INPUT (RECORDING LEVEL) CONTROLS

Use these to adjust the level of the input signals from the MIC jacks or rear panel INPUT jacks.

Turning these controls to the right increases the level. The controls are coupled to the left and right channels, but you can use them to adjust the right channel (back) and the left channel (front) independently by rotating the appropriate control and holding the other in position.

⑨ HEADPHONE JACK

This is the output jack for stereo headphones. Plug your headphones into this jack when you want to listen to a tape privately.

NOTES:

- Use low-impedance headphones. If you use a high-impedance model, you will not be able to obtain sufficient volume.
- Do not connect a microphone to this jack as the microphone may be damaged.

⑩ MIC JACKS

These are the input jacks for microphone recording. Plug the left channel microphone into the L jack and the right channel microphone into the R jack.

⑪ TAPE SELECTOR SWITCH

This selector allows the bias and equalizer characteristics to be selected during recording and the equalizer characteristics during playback in line with the type of tape you are using.

METAL position: For using metal tapes

NORM position: For using standard or LH tapes

CrO₂ position: For using chrome tapes

⑫ DOLBY* NR SWITCH

Set this switch to ON for recording with the built-in Dolby noise reduction system and for playback of tapes which have been recorded using the Dolby NR system.

*Manufactured under license from Dolby Laboratories.

*Dolby and  are trademarks of Dolby Laboratories.

⑬ OPERATING SWITCHES

◀ (REW): Depress this switch to rewind the tape at high speed. (The tape will travel from right to left.)

▶ (FF): Depress this switch to send the tape forward at high speed. (The tape will travel from left to right.)

■ (Stop): Depress this switch to stop the tape run and to release the operating mode.

▶ (Play): Depress this switch when playing back a tape. (The tape will travel from left to right.)

REC: Depress this switch together with the ▶ (Play) switch for recording. This switch will not work when a cassette is not loaded or when the erasure prevention tabs of a loaded cassette have been broken off.

PAUSE: Depress this switch to stop the tape temporarily during recording or playback. Depress ▶ (Play) switch to allow the tape to continue to travel.

NOTE:

If the POWER switch is set to the OFF position while the deck is operating (in any mode), all the operating mode will be released (shutdown mode).

⑭ TIMER START SWITCH

This is used when the timer is employed along with the deck for unattended recording and wake up playback.

REC: Set to this position to set the deck automatically to the recording mode at the time preset on the timer and to start the recording of programs unattended, for instance.

OFF: Set to this position for normal tape playback and recording.

PLAY: Set to this position to set the deck automatically to the playback mode at the time preset on the timer and to start the playback. The tape playback function can be used to wake up in the morning instead of an alarm clock.

3. BLOCK DIAGRAM

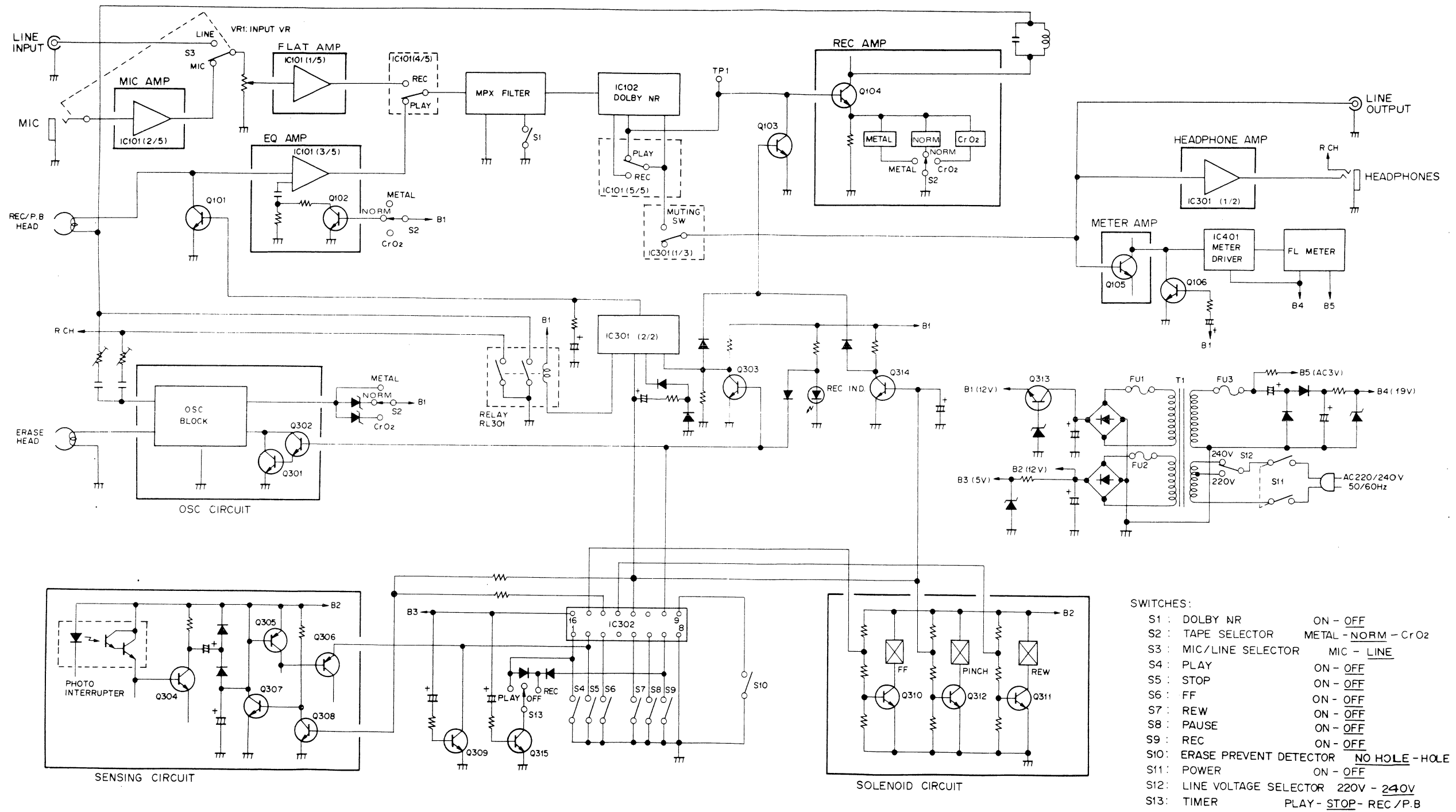

4. LEVEL DIAGRAM

Playback Mode

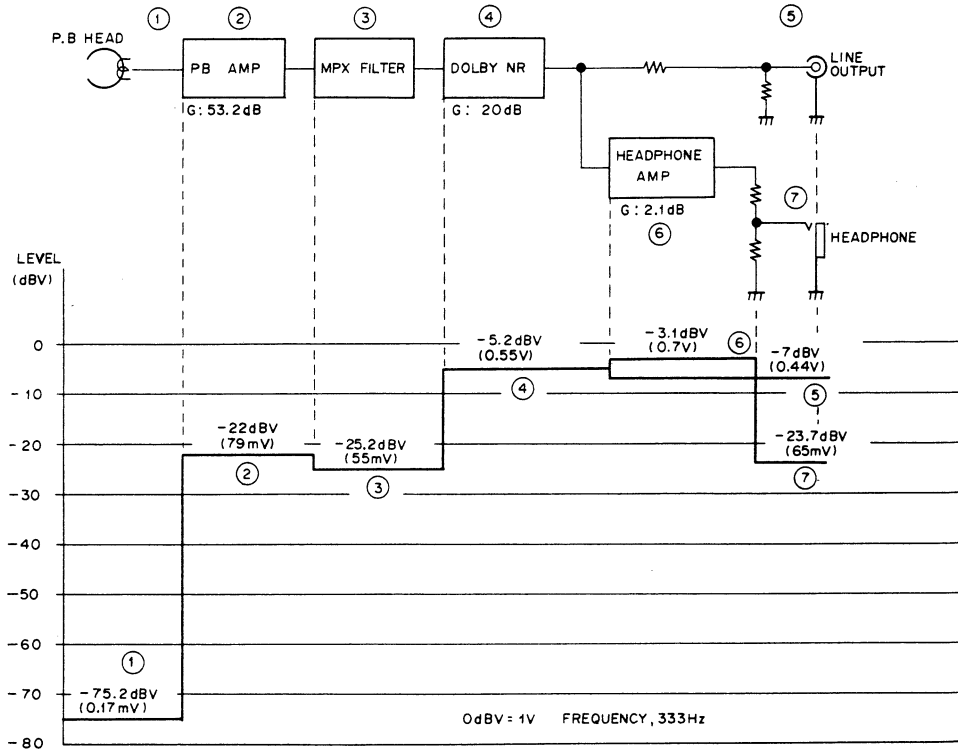

Recording Mode

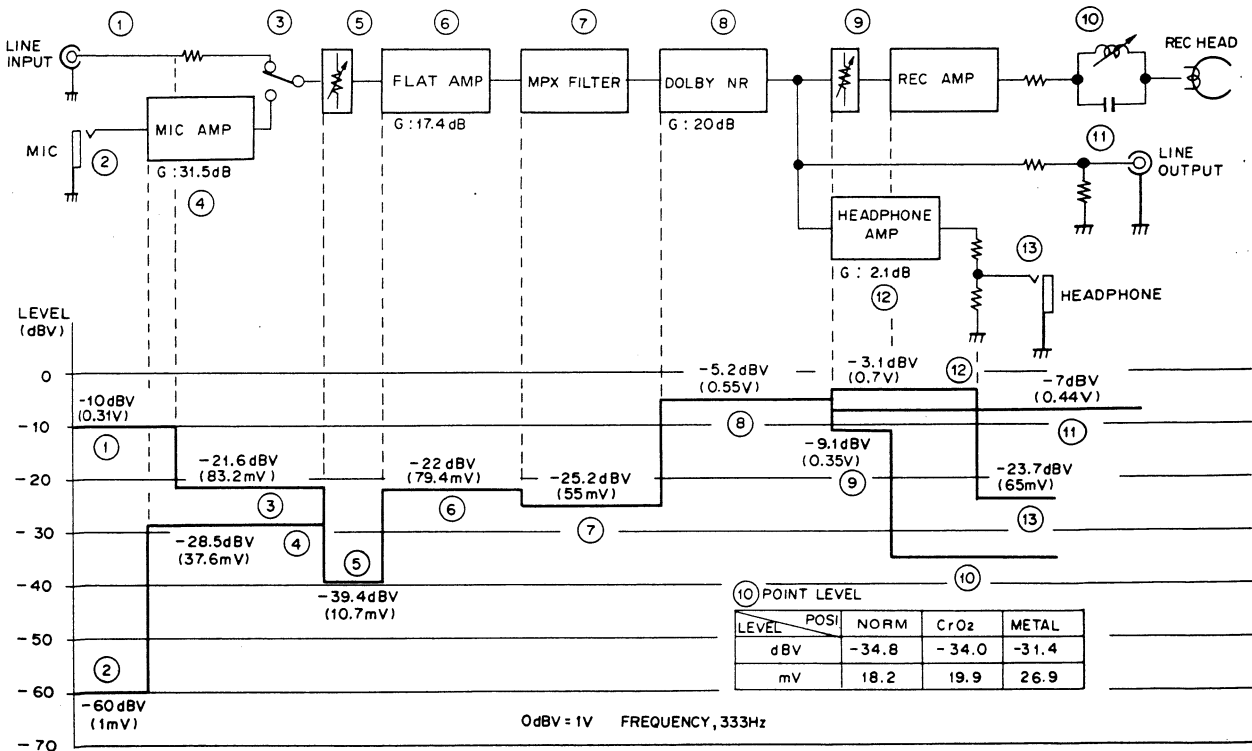

10 POINT LEVEL

LEVEL	POSI	NORM	CrO2	METAL
dBV		-34.8	-34.0	-31.4
mV		18.2	19.9	26.9

5. PARTS LOCATION

- The \triangle mark found on some component parts indicates of the importance of the safety factor of the part. Therefore, when replacing, be sure to use parts of identical designation.

Front Panel View

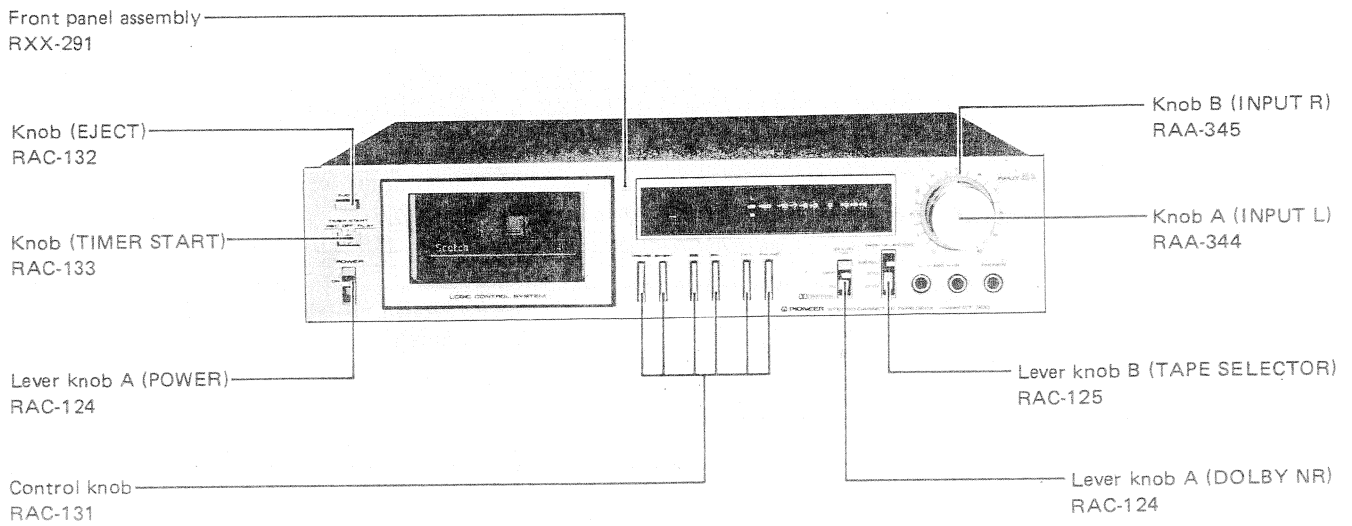

Front View with Front Panel Removed

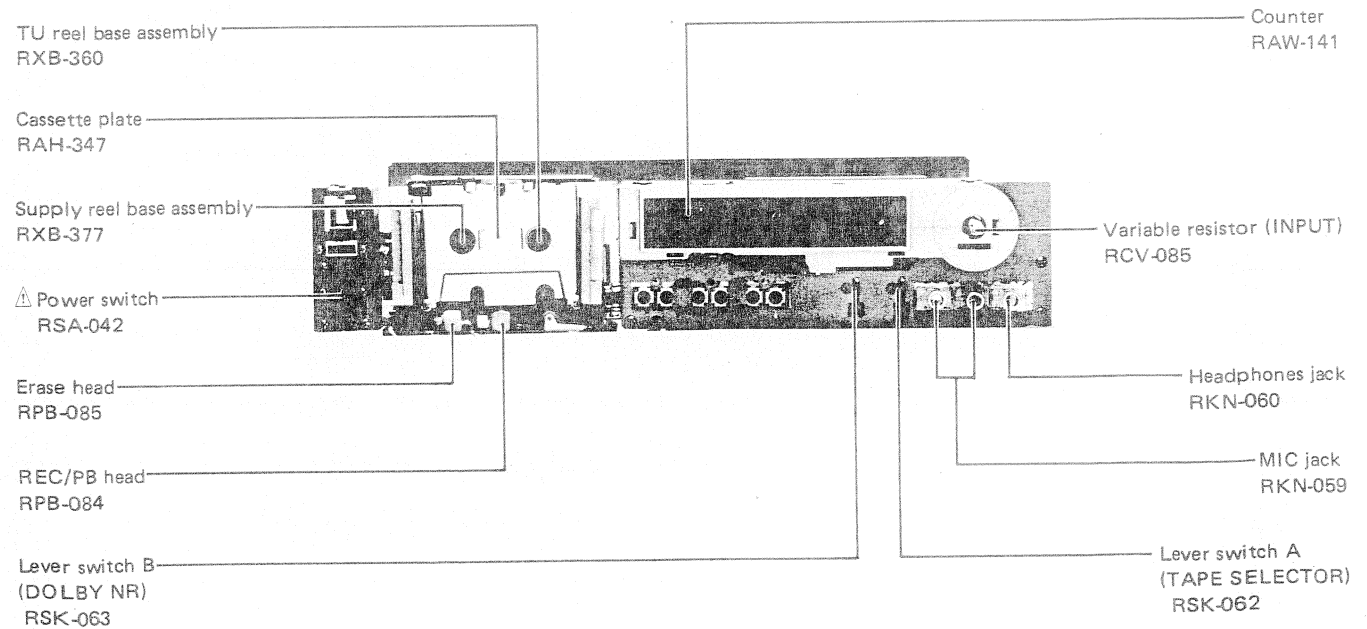

Top View with Bonnet Removed

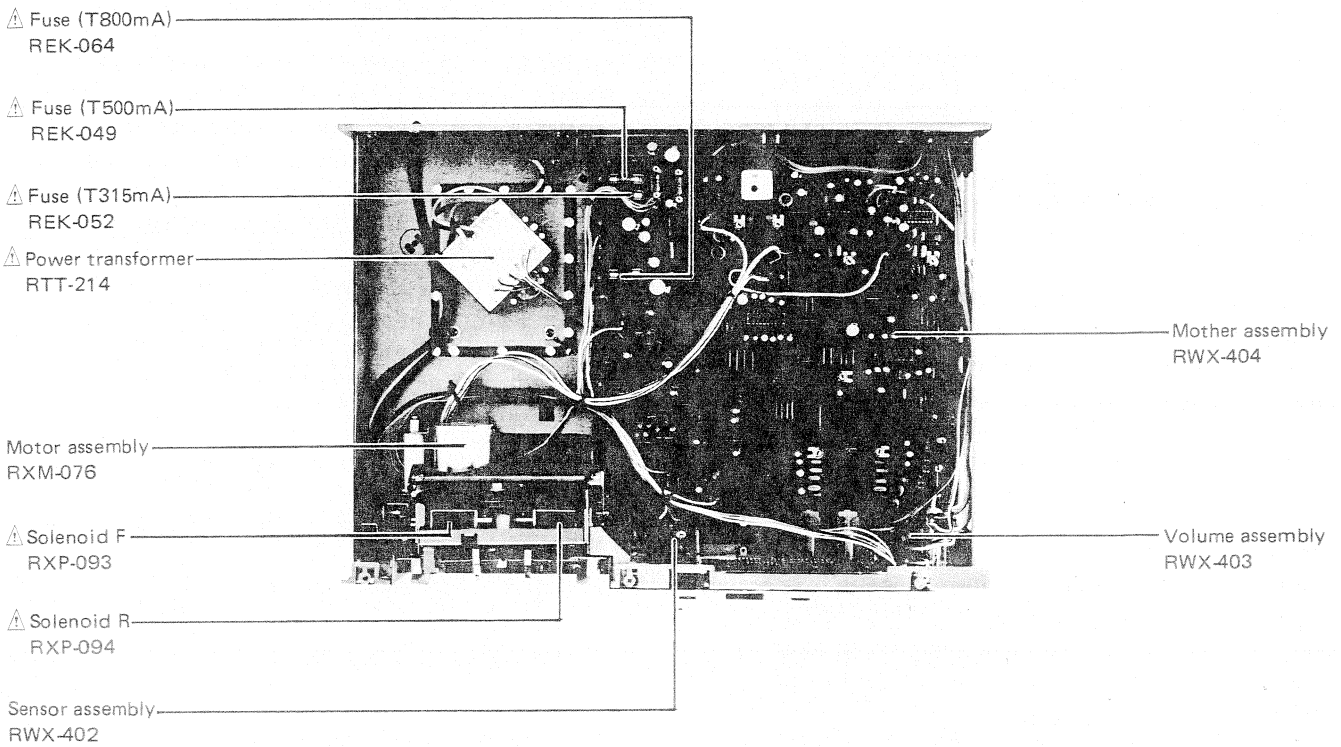

Rear Panel View

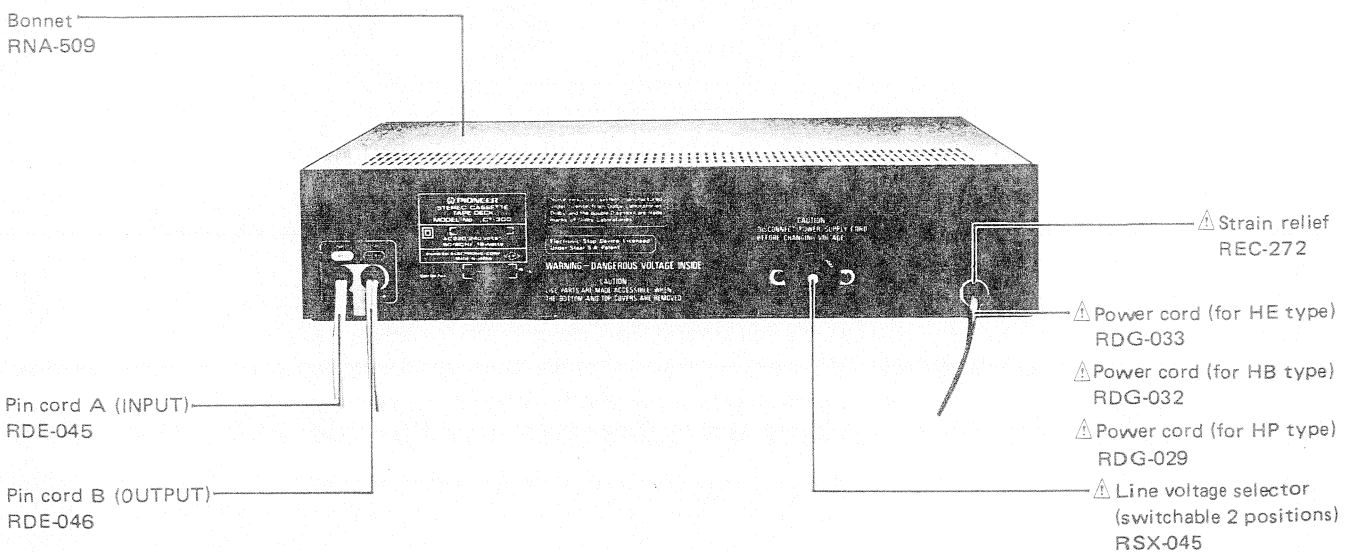

6. CIRCUIT DESCRIPTIONS

6.1 SIGNAL PATHS

Recording Mode

The signal from MIC is first amplified to the fixed level by the MIC amplifier (HA12005) and then applied via the MIC position of the S3; MIC/LINE selector (MIC position switched in automatically when microphone plugged into the MIC jack) to the VR1; INPUT level control, flat amplifier (HA12005), MPX filter, and DOLBY NR circuit.

The signal from the LINE INPUT is passed via S3 to the INPUT level control, flat amplifier, MPX filter, and DOLBY NR circuit. After the frequency response has been equalized by the recording amplifier (Q104) equalizer circuit (according to the type of tape being employed), the output signal is applied to the recording head.

Play Mode

The signal from the playback head is first equalized in the playback equalizer amplifier (HA12005) according to the type of tape being employed, and then it is amplified to the fixed level. The output of DOLBY NR is then applied to the LINE OUTPUT via the REC/PB switch (located HA12005) and MUTE switch (located HA12006).

6.2 LEVEL METER CIRCUIT

After the output from the muting amp has been amplified by transistor Q105, it is rectified by D103 and D104. This direct current is supplied to the display driver IC (IC401). There are 12 display comparators within the display driver IC serving to adjust the up-down level by driving each segment. +B is connected to the comparator's negative sides, and sets the standard voltage for them. The standard voltage applied to the comparators is sequentially lowered by the ones with a lower level. The voltage is then compared with the DC rectified by D103 and D104, and when the compared voltage is greater than standard, the segments are lighted.

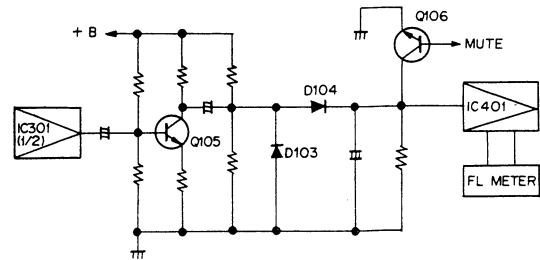

Fig. 6-1 Level meter circuit

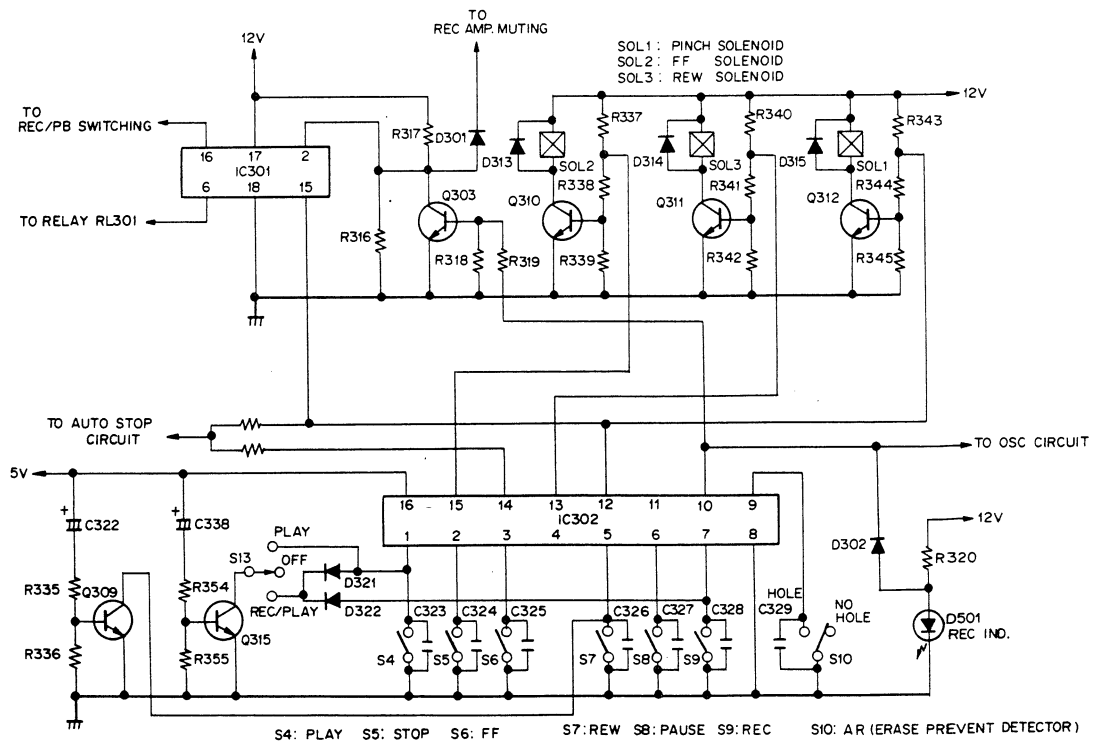

Fig. 6-2 Control circuit

6.3 CONTROL CIRCUIT

The control circuit employed in this tape deck IC(BA843) for use in the electronic control of the switching. See Fig. 6-3 and Fig. 6-4 for the corresponding pin arrangement and input/output truth table.

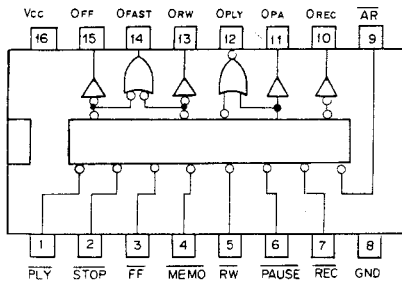

Fig. 6-3 Pin arrangement of BA843

For 1.5 ~ 2.5 seconds after the power has been turned on, Q309 is ON (until charge-amp C322 has completed). Since IC302 (2 pin) is at a LOW level, it is in a STOP status and no key is operable.

Play Operation

1. When play switch S4 is pressed ON, IC302 (12 pin) goes to a high level (hereafter called H level). This causes +B to flow through R343, R344, and Q312, turning Q312 ON.
2. The pinch solenoid (P.S.) is activated starting play operation.

Record Operation

1. Loading a cassette with an erase prevention detector (AR SW S10 is on no hole side), press play switch S4 and record switch S9 simultaneously.
2. IC302 (12 pin) and (10 pin) go to H level, current flows from R319 to Q303 and Q303 comes ON. IC301 (HA12006) (2 pin) goes to a low level (hereafter called L level).

3. As IC301 (2 pin) goes to L level, IC301 (6 pin) and (16 pin) go to H level and the head goes to a record status.
4. At the same time, as was noted earlier, IC302 (10 pin) goes to H level and the bias oscillator comes ON.
5. When a cassette without an erase prevention detector, AR SW is on the hole side, IC302 (9 pin) is shorted to ground causing IC302 (10 pin) not to go to H level, and preventing recording.

FF, REW Operation.

1. Pressing FF switch S6 to ON causes IC302 (15 pin) to go to H level. +B flows through R337, R338, and Q310 and Q310 comes ON.
2. FFS (Fast Forward Solenoid) becomes operative and FF operation begins.
3. Rewind operation is essentially the same as FF.

Pause Operation

When either in the play or record mode, pressing the pause switch S8 to ON causes IC302 (12 pin) to go from an H level to an L level. This causes Q312 to go OFF, releasing the pinch solenoid and temporarily stopping play or record.

Timer Start Operation

- Play operation
1. Turn the timer switch S13 to PLAY, and turn the power on at the timer.
 2. As the power comes on, Q315 comes ON by the charge current from C338, and Q309 by the charge current from C322. (As determined by the time constant circuit C338, R354, and R355, Q315 requires 3-5 seconds; and Q309 requires 1.5 ~ 2.5 seconds as determined by C322, R335, and R336.) IC302 (1 pin) and (2 pin) go to L level.
 3. While IC302 (2 pin) is at L level, IC302 (12 pin) is also at L level.

Input signal	Output						Output mode
	0-FAST	0-FF	0-RW	0-REC	0-PAUSE	0-PLAY	
STOP	L	L	L	L	L	L	STOP mode
FF	H	H	L	L	L	L	FF mode
RW	H	L	H	L	L	L	REW mode
PLAY	L	L	L	L	L	H	PLAY mode
PAUSE	L	L	L	L	H	L	PAUSE mode
REC/PLAY	L	L	L	H	L	H	REC/PLAY mode
REC/PAUSE	L	L	L	H	H	L	REC/PAUSE mode

Fig. 6-4 Input/output truth table

- After C322 has completed charging, Q309 goes OFF and IC302 (2 pin) goes to H level. Since at that time, IC302 (1 pin) is at L level, IC302 (12 pin) will be at H level supplying current to the base of Q312. Q312 goes ON, PS is activated, and play operation commences.

■ Record/Play operation

- Turn the timer switch S13 to REC/PLAY and turn the power ON at the timer. IC302 (1 pin), (2 pin), and (9 pin) will go to L level.
- While IC302 (2) is at L level, IC302 (10 pin) and (12 pin) is also at L level.
- After C322 has completed charging up, Q309 goes OFF, and IC302 (2 pin) goes to H level. Since at this time IC302 (1 pin) and (9 pin) are L level, IC302 (10 pin) and (12 pin) are at H level and operation is the same as REC operation.

Auto-stop Circuit

When the tape has reached the end of its travel, the control IC goes into the STOP mode, stopping the mechanism. A photo-interruptor is used as the tape travel sensor. It is connected by belt to the take-up reel and uses fan blades to intercept the path of light.

- During tape travel, the turning of the fan causes the photo-interruptor to generate a pulse signal. This causes Q304 to cycle ON-OFF and C321 repeats a charge-discharge cycle.
- When tape travel stops, the signal from the photo-interruptor is lost, and Q304 stops its switching operation. +B charges C321 by route of R326 → R327 → C321. Along with the charging of C321, the potential at the base of Q305 rises and Q305 goes OFF. When Q305 goes OFF, Q306 goes ON, IC302 goes to STOP mode and operation ceases. This circuit is only effective during PLAY, FF and REW operations.

6.4 MUTING CIRCUIT

This set uses an IC-HA12006 for line output muting. This IC (IC301) is only effective in muting when REC input (2 pin) is at H level st the same time PLAY input (15 pin) is at L level. [IC301 (12 pin) gose L level]

FF/REW/STOP

At FF, REW, and STOP, IC302 (10 pin) and (12 pin) are both at L level. When IC302 (12 pin) is at L level, IC301 (15 pin) is also at L level, and when IC302 (10 pin) is at L level, Q303 is OFF. This causes IC302 (2 pin) to go to H level, muting LINE OUT, and current to flow from IC301 (2 pin) through the route D301 → R154 → Q103, muting the record amp.

Turning the Power Switch ON

When the power switch is turned ON, as was mentioned previously, the set is in a STOP status for 1.5 ~ 2.5 seconds after the power is turned on, and LINE OUT and the record amp is muted. Also current flows through the route C334 → R360 → R161 → Q106 and Q106 goes to ON. The meter is muted until C334 is charged up and Q106 goes to OFF.

Going from STOP Status to PLAY

When going from STOP to PLAY, IC302 (12 pin) goes from L level to H level and through C315 → R349 → D304, sends current to IC301 (1 pin), muting LINE OUT. Muting continues until C315 is charged up. (approx. 0.6 sec.)

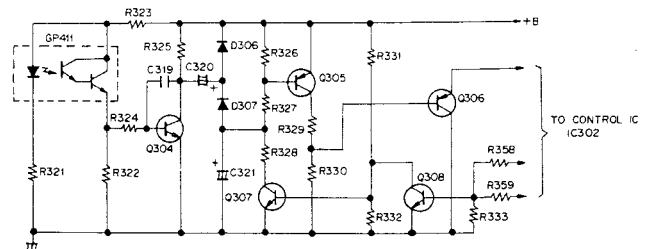

Fig. 6-5 Auto-stop circuit

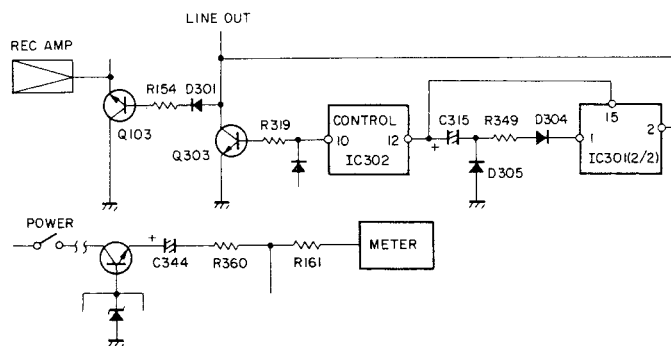
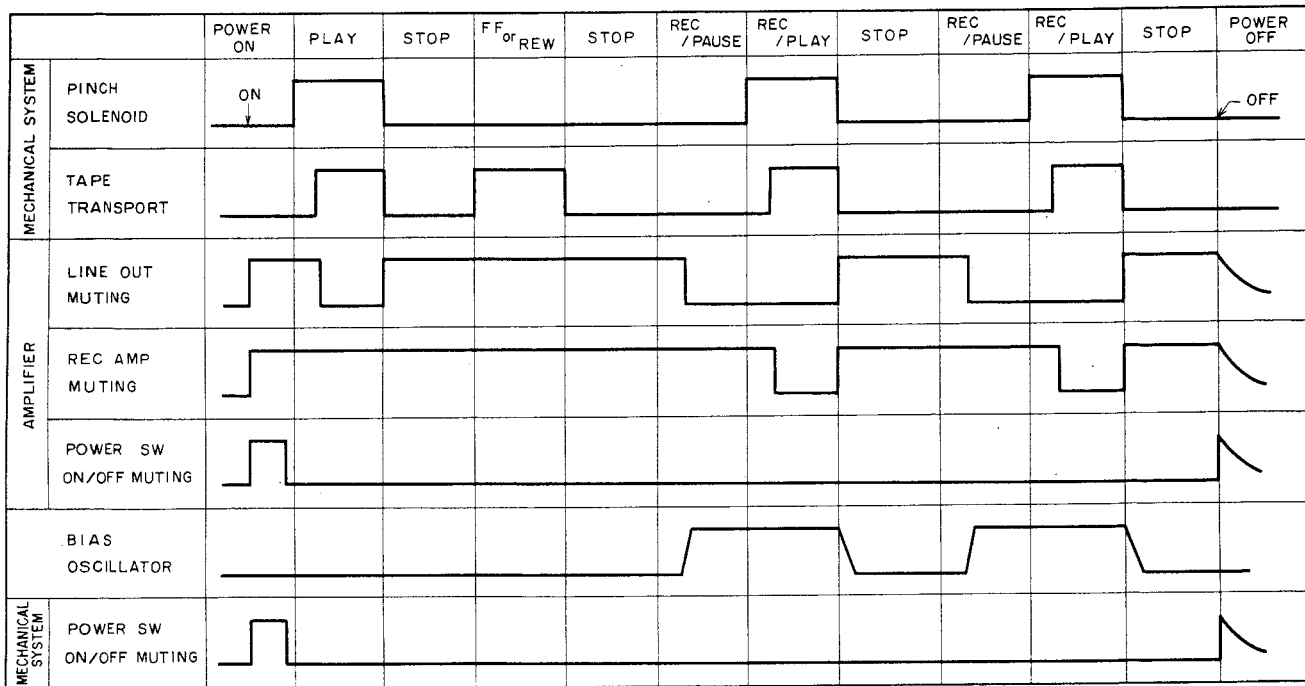

Fig. 6-6 Muting circuit

6.5 TIMING CHART

NORMAL OPERATION



DIRECT CHANGE

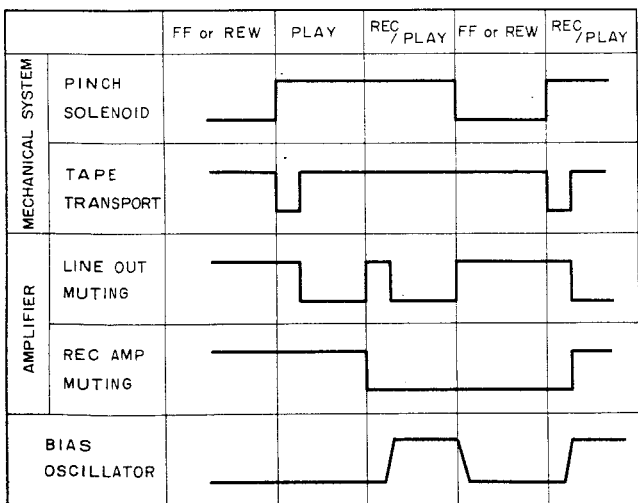

AUTO START

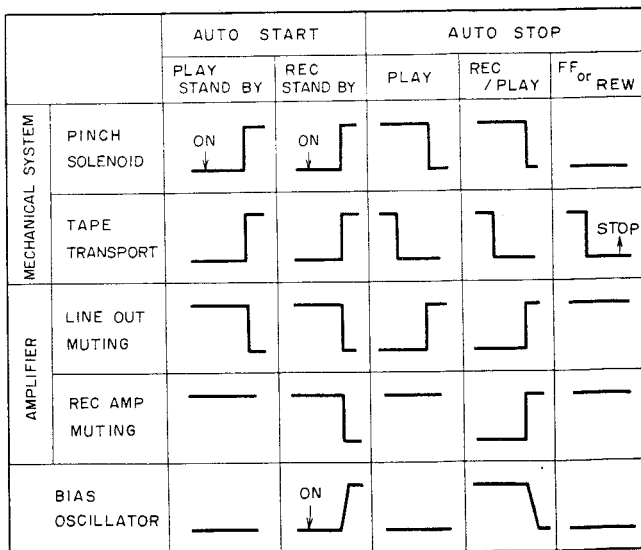

7. MECHANICAL ADJUSTMENTS

7.1 PINCH ROLLER PRESSURE ADJUSTMENT

1. Put the tape deck into the playback mode.
2. Gently push against the pinch roller arm with the tension gauge (Part No. GKG-047) and separate the pinch roller slightly from the capstan.
3. Then the pinch roller back onto the capstan, and read the value when the pinch roller starts to rotate. If the reading fails to lie within 350g ~ 550g, replace the pinch roller pressure spring (Part No. RBH-742).

7.2 REEL BASE TORQUE ADJUSTMENT

Prior to adjustment

Clean the both reel base, the capstan and the pinch roller with an alcohol moistened swab.

Adjustment

Measure the torque with the torque meter during playback, fast forward (FF) and rewind (REW) modes. The measured values should normally lie within the allowable ranges listed in the table 1 below.

If the measured values lie outside the relevant ranges, replace the TU (take-up) reel base assembly and/or supply reel base assembly (Part No. RXB-377), or driving arm full assembly (Part No. RXB-376).

Torque meter

Part No.	Description	Remarks
STD-605	Cassette test tape	FF/REW torque Adjustment

Table 1

	TU reel base	Supply reel base
Playback mode	35 ~ 50g·cm	*2 ~ 5g·cm
FF mode	72 ~ 100g·cm	*1 ~ 5g·cm
REW mode	*2 ~ 5g·cm	72 ~ 110g·cm

* denotes back tension torque

7.3 TAPE SPEED ADJUSTMENT

1. Connect the frequency counter to the OUTPUT terminals (to pin code).
2. Playback the 3kHz portion of the STD-301 test tape. At the beginning, the frequency should be lie within the 2995Hz ~ 3010Hz range, and may be adjusted by turning the semi-fixed resistor located in the capstan motor adjustment hole as shown in Fig. 7-2.

Tape speed is increased by turning the semifixed resistor clockwise, and decreased by turning counter-clockwise.

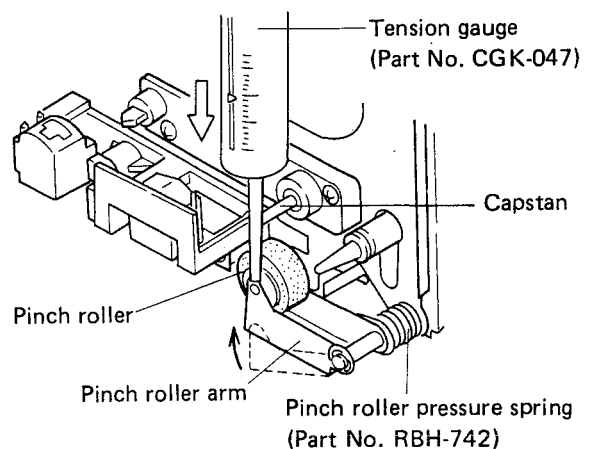

Fig. 7-1 Pinch roller pressure adjustment

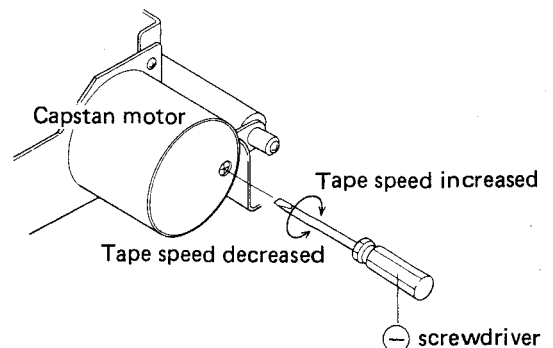

Fig. 7-2 Tape speed adjustment

7.4 REC DETECTOR SWITCH ADJUSTMENT

Adjust the tang (↔) shown in Fig. 7-3 by the arrow to a position where when a cassette with an erase prevention detector is loaded into the holder, the lever switch is ON, and when a cassette without the detector is loaded, the switch is OFF.

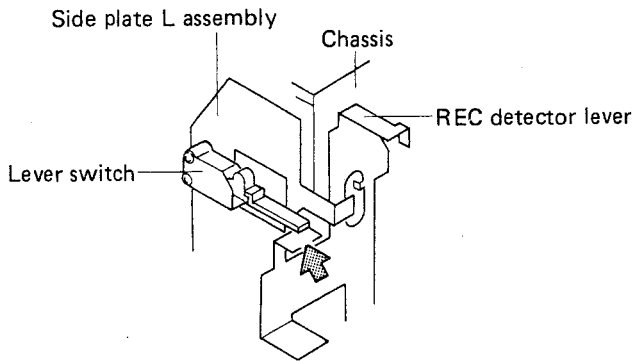

Fig. 7-3 REC detector switch adjustment

7.5 FF SOLENOID ADJUSTMENT

1. Put the deck into FF mode.
2. Loosen screws ❶ and adjust the FF solenoid mounting position so that the square hole of the reel base full assembly is flush against the boss of the driving arm full assembly (i.e. 0 separation) as shown in Fig. 7-4.

7.6 REW SOLENOID ADJUSTMENT

1. Put the deck into REW mode
2. Loosen screws ❷ and adjust the REW solenoid mounting position so that the square hole of the reel base full assembly is flush against the boss of the driving arm full assembly (i.e. 0 separation) as shown in Fig. 7-4.

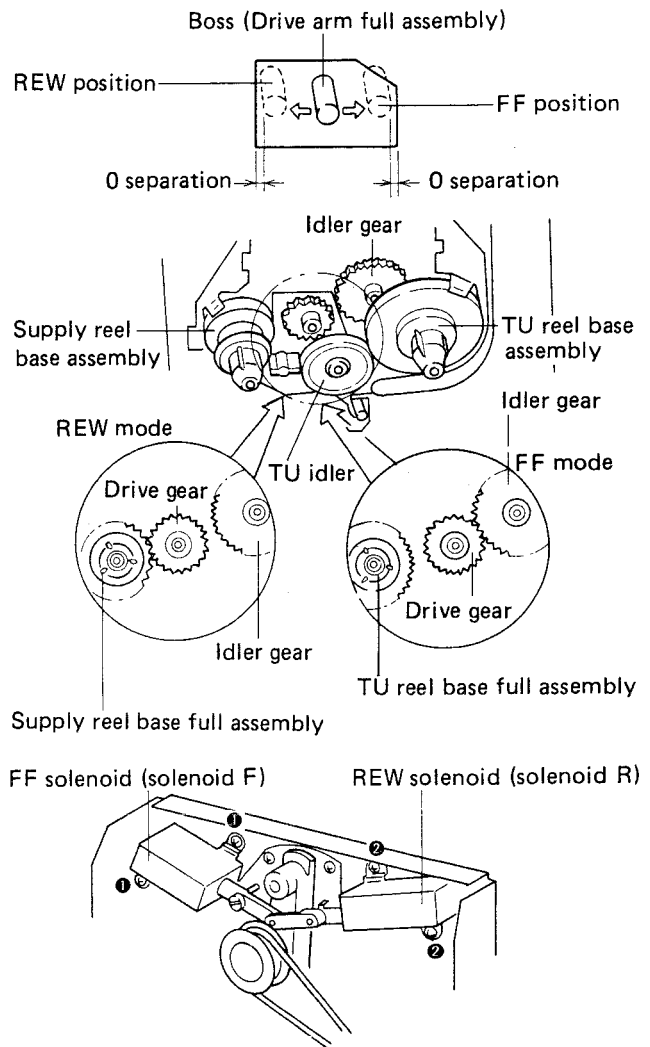

Fig. 7-4 FF (REW) solenoid adjustment

8. ELECTRICAL ADJUSTMENTS

Precaution

1. Mechanical adjustment should be completed.
2. Clean the following parts with an alcohol moistened swab: Record/Playback head, Pinch roller, Erase head, Rubber belts and Capstan.
3. Demagnetize record/playback head with a head demagnetizer.
4. Do not use magnetized screwdriver for adjustments.
5. Adjustments and measurements should be performed for both L-ch and R-ch with rated power supply voltage.
6. Adjustments should be performed in the order given in this service manual. Altering the order can hinder proper adjustments, resulting in loss of performance.
7. Level during measurements are based on 0dBv = 1V. Connect a 50kΩ dummy resistor across the OUTPUT terminals.
8. Let the CT-300 warm up (aging) for a few minutes before proceeding with the adjustment.
9. Set the DOLBY NR switch OFF unless directed otherwise.

Test Equipments/Tools Required;

1. Test tape
 STD-331A..... for general playback purpose
 STD-341A..... for playback adjustment
 STD-601..... NORMAL blank tape
 STD-603..... CrO₂ blank tape
 STD-604..... METAL blank tape
2. Audio oscillator
3. AC millivoltmeter (AC mV)
4. Attenuator
5. Oscilloscope
6. Resistor 50kΩ (¼ W)

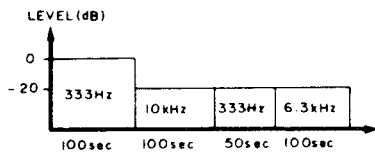

Fig. 8-1 Contents of the test tape STD-341A

8.1 HEAD AZIMUTH ADJUSTMENT

Setting:

MODE..... Playback
 TAPE SELECTOR..... NORM
 VR101, VR201..... Max.
 TEST TAPE..... STD-341A
 AC mV meter..... OUTPUT terminals

Procedure:

Adjust the azimuth adjusting screw for maximum AC mV meter readings for both L and R channels.

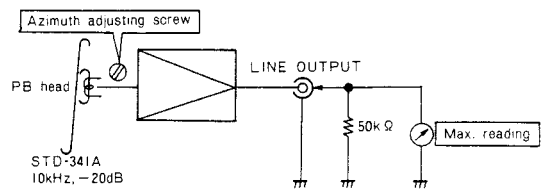

Fig. 8-2 Head azimuth adjustment

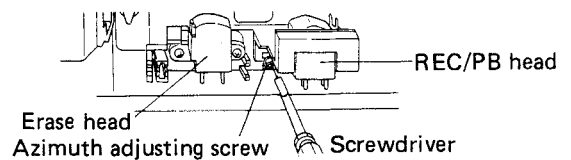

Fig. 8-3 Head azimuth adjustment

8.2 PLAYBACK EQUALIZER CHECK

Setting:

MODE..... Playback
 TAPE SELECTOR..... NORM, METAL (or CrO₂)
 TEST TAPE..... STD-341A
 AC mV meter..... OUTPUT terminals

Procedure:

1. Set the TAPE SELECTOR to the NORM position. Playback the 333Hz and 6.3kHz portions of the STD-341A test tape, and check that the difference in output level between two is +0.5dB ± 1dB.
2. Next set the TAPE SELECTOR to the METAL (or CrO₂) position. Playback the 333Hz and 6.3kHz portions of the STD-341A test tape, and check that the difference in output level between two is -3.5dB ± 1dB.

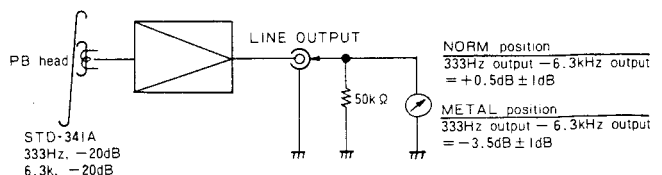

Fig. 8-4 Playback equalizer check

8.3 PLAYBACK LEVEL ADJUSTMENT

Since this adjustment determines the DOLBY NR level during playback, it should be performed precisely.

Setting:

MODE Playback
 TAPE SELECTOR NORM
 TEST TAPE STD-341A
 AC mV meter TP1 (Lch) and TP2 (Rch)
 of the mother assembly

Procedure:

Adjust the VR101 (Lch) and VR201 (Rch) so that the AC mV meter reads -1.2dBv (0.87V).

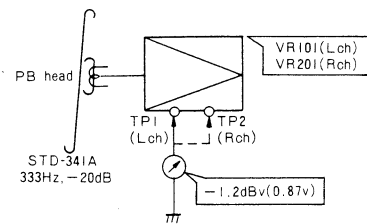

Fig. 8-5 Playback level adjustment

8.4 F.L. METER INDICATION CHECK

Setting:

MODE Record
 Input signal (INPUT) .. 333Hz, -10dBv (316mV)
 AC mV meter TP1 (Lch) and TP2 (Rch)
 of the mother assembly

Procedure:

Adjust the INPUT level control so that the AC mV meter reads -5.2dBv (0.54V). Then check the F.L. meter indication is $0\text{dB} \pm 1\text{dB}$.

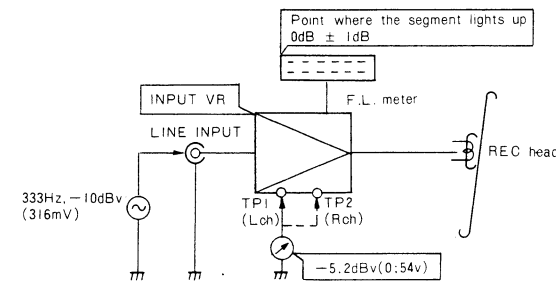

Fig. 8-6 F.L. meter indication check

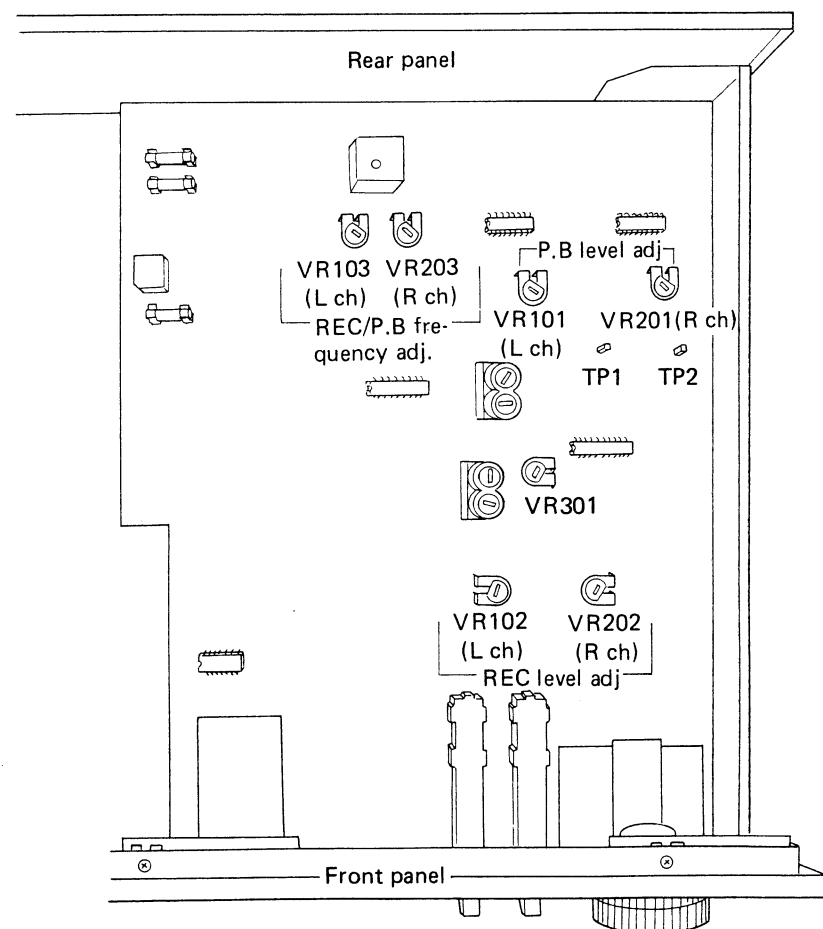

Fig. 8-7 Adjustment points

8.5 RECORDING / PLAYBACK FREQUENCY RESPONSE ADJUSTMENT

Setting:

MODE Record
 TAPE SELECTOR NORM
 INPUT SIGNAL (INPUT) 333Hz, -30dBv (31mV)
 TEST TAPE STD-601
 AC mV meter OUTPUT terminals

Procedure:

- Set the TAPE SELECTOR to the NORM position. Apply the 333Hz, -30dBv (31mV) signal to the INPUT terminals, and adjust the INPUT level control so that the AC mV meter reads -27dBv (44.6mV).
- Record the 333Hz and 6.3kHz signals onto the STD-601 test tape. Playback the tape and adjust the VR103 (Lch) and VR203 (Rch) so that the AC mV meter reads $0\text{dB} \pm 0.5\text{dB}$ of the 333Hz signal.

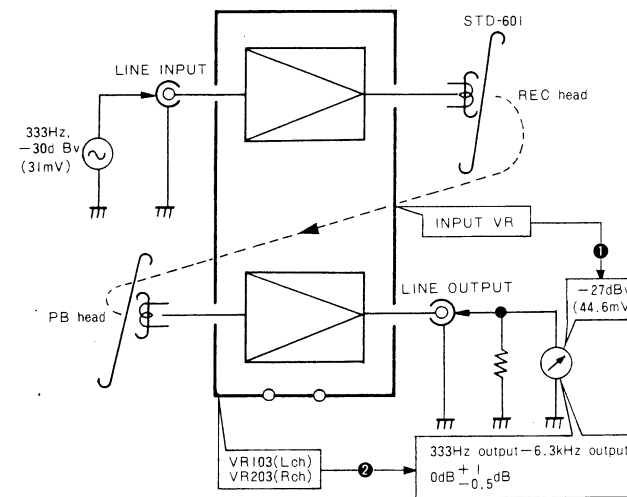
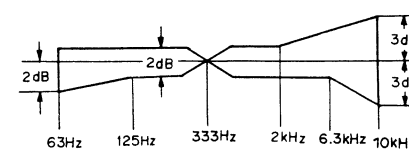

Fig. 8-8 Recording/Playback frequency response adjustment

Frequency Response

Using STD-331A and the TAPE SELECTOR NORM position, with DOLBY NR OFF. However, the right channel is compensated by -1dB at 63Hz, and -0.5dB at 125Hz because of the insulation effect.



Overall Frequency Response

Using STD-601 and TAPE SELECTOR NORM position, with DOLBY NR OFF

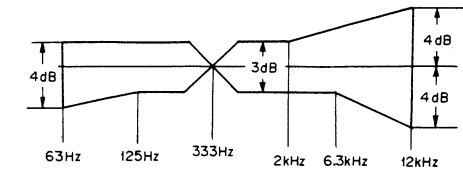

Using STD-601 and TAPE SELECTOR NORM position, with DOLBY NR ON

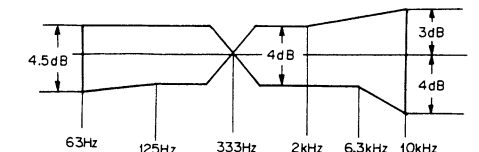

Using STD-603 and TAPE SELECTOR CrO2 position, with DOLBY NR OFF

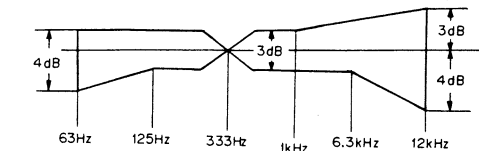

Using STD-603 and TAPE SELECTOR CrO2 position, with DOLBY NR ON

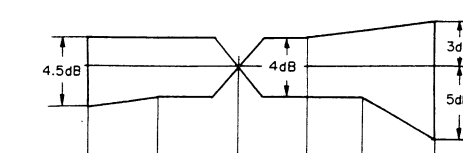

Using STD-604 and TAPE SELECTOR METAL position, with DOLBY NR OFF

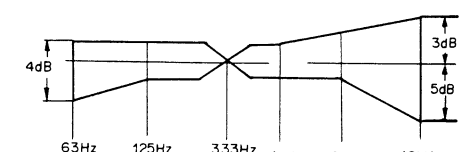

Using STD-604 and TAPE SELECTOR METAL position, with DOLBY NR ON

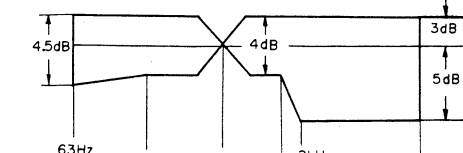

Fig. 8-9 Frequency response

8.5 RECORDING / PLAYBACK FREQUENCY RESPONSE ADJUSTMENT

Setting:
 MODE Record
 TAPE SELECTOR NORM
 INPUT SIGNAL (INPUT) 333Hz, -30dBv (31mV)
 TEST TAPE STD-601
 AC mV meter OUTPUT terminals

- Procedure:**
1. Set the TAPE SELECTOR to the NORM position. Apply the 333Hz, -30dBv (31mV) signal to the INPUT terminals, and adjust the INPUT level control so that the AC mV meter reads -27dBv (44.6mV).
 2. Record the 333Hz and 6.3kHz signals onto the STD-601 test tape. Playback the tape and adjust the VR103 (Lch) and VR203 (Rch) so that the AC mV meter reads 0dB. Then confirm that the playback output deviation of the 6.3kHz signal is within 0dB \pm 0.5 dB of the 333Hz signal.

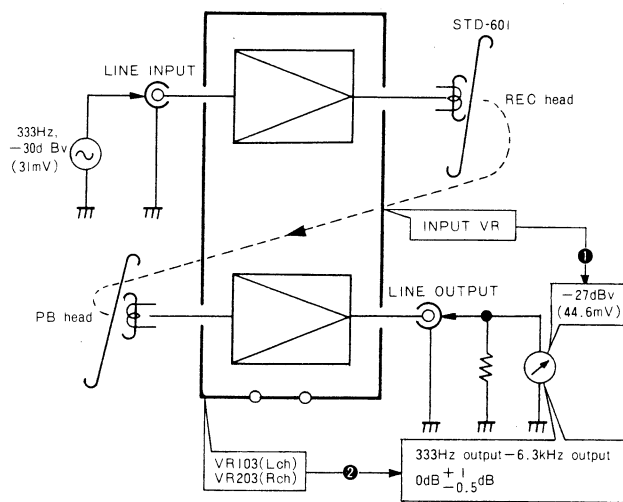

Fig. 8-8 Recording/Playback frequency response adjustment

Frequency Response

Using STD-331A and the TAPE SELECTOR NORM position, with DOLBY NR OFF. However, the right channel is compensated by -1dB at 63Hz, and -0.5dB at 125Hz because of the insulation effect.

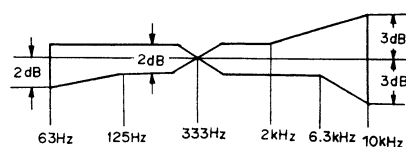
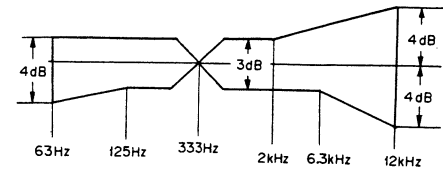

Fig. 8-9 Frequency response

Overall Frequency Response

Using STD-601 and TAPE SELECTOR NORM position, with DOLBY NR OFF



Using STD-601 and TAPE SELECTOR NORM position, with DOLBY NR ON

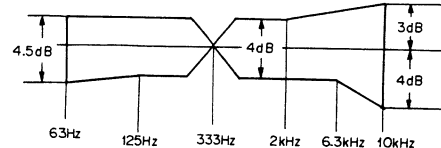

Using STD-603 and TAPE SELECTOR CrO₂ position, with DOLBY NR OFF

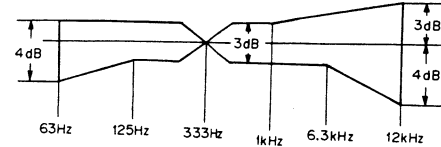

Using STD-603 and TAPE SELECTOR CrO₂ position, with DOLBY NR ON

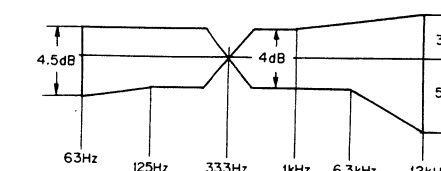

Using STD-604 and TAPE SELECTOR METAL position, with DOLBY NR OFF

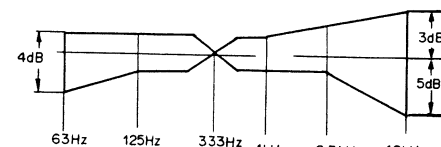

Using STD-604 and TAPE SELECTOR METAL position, with DOLBY NR ON

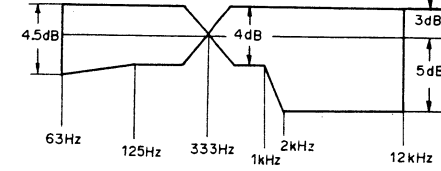

8.6 RECORDING LEVEL ADJUSTMENT

Since this adjustment determines the DOLBY NR level during recording, it should be performed precisely.

Setting:
 MODE Record
 TAPE SELECTOR NORM, CrO₂, METAL
 INPUT SIGNAL (INPUT) 333Hz, -10dBv (316 mV)
 TEST TAPE STD-601, STD-604
 AC mV meter TP1 (Lch) and TP2 (Rch) of the mother assembly

DOLBY NR SWITCH ... OFF → ON

Procedure:

1. Set the TAPE SELECTOR to the NORM and DOLBY NR switch to the OFF position. Apply the 333Hz signal to the INPUT terminals, and adjust the INPUT level control so that the AC mV meter reads -5.2dBv (0.54V).
2. Next the DOLBY NR switch to the ON position and record the 333Hz signal onto the STD-601 test tape. Playback the signal and adjust the VR102 (Lch) and VR202 (Rch) so that the AC mV meter reads -5.2dBV (0.54V).

3. Set the TAPE SELECTOR to the CrO₂ position and record the 333Hz signal onto the STD-603 test tape. Playback signal and check that the AC mV meter reads -5.2dBV (0.54V) \pm 1.5dB.
4. Set the TAPE SELECTOR to the METAL position and record the 333Hz signal onto the STD-604 test tape. Playback signal and check that the AC mV meter reads -6.2dBV (0.48V) \pm 1.5dB.

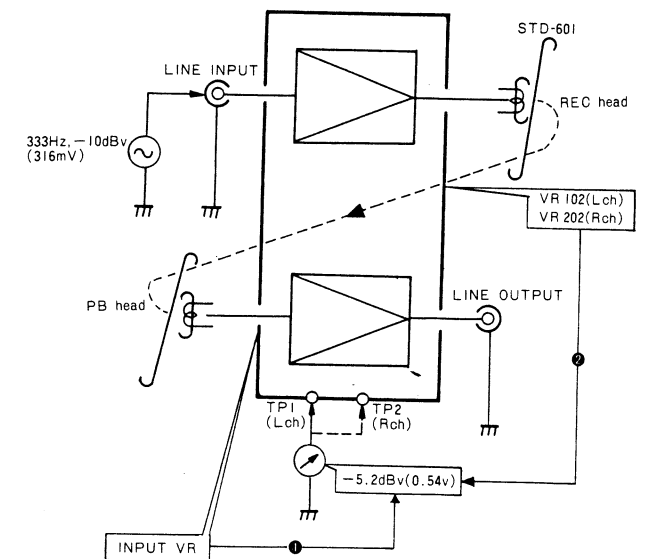

Fig. 8-10 Recording level adjustment

9. SCHEMATIC DIAGRAM

A

B

C

D

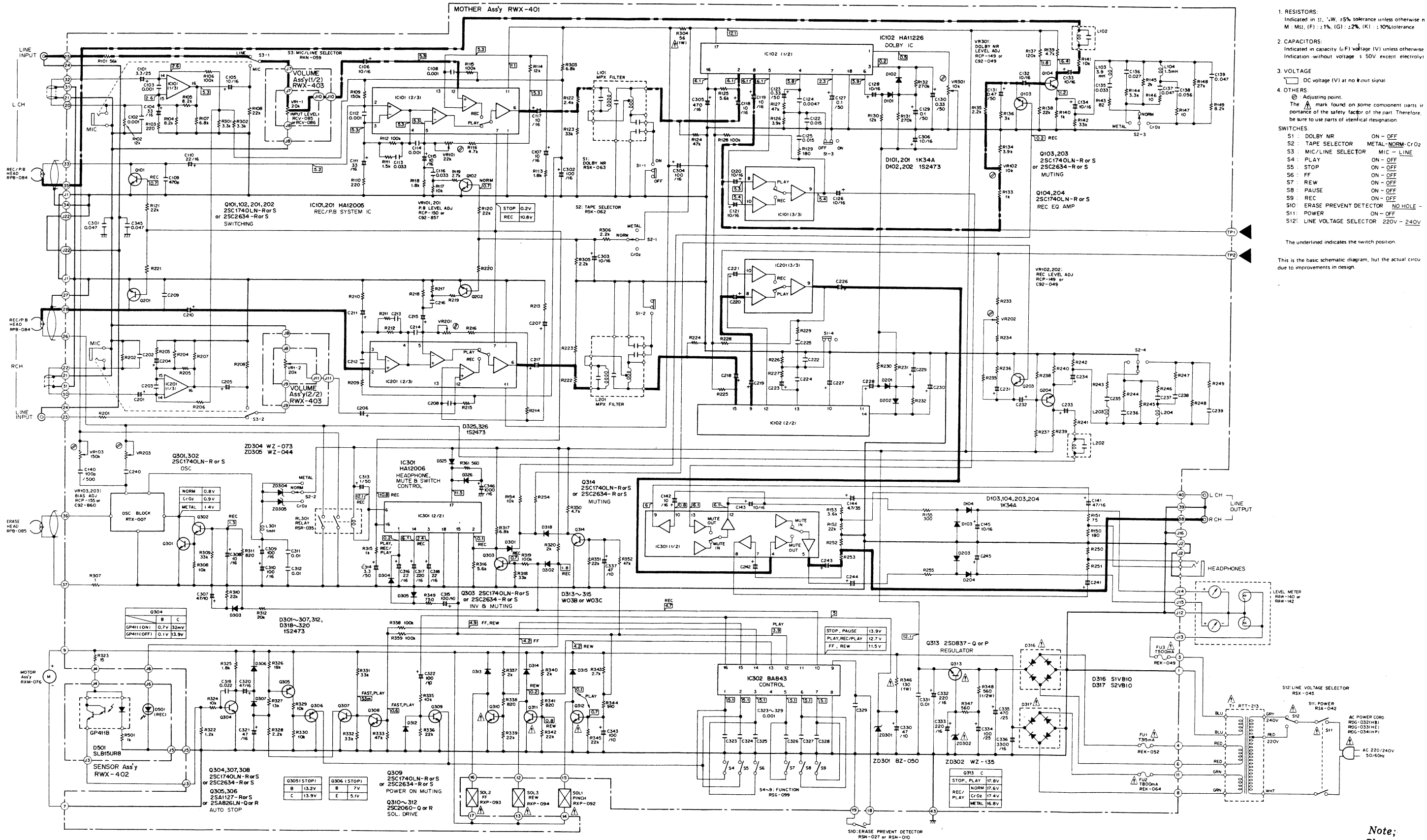

1. RESISTORS:
Indicated in Ω, kΩ, ±5% tolerance unless otherwise noted.
M: 1%, F: 1%, G: 2%, K: 10% tolerance
 2. CAPACITORS:
Indicated in capacity (μF) voltage (V) unless otherwise indicated without voltage ≤ 50V except electrolytic
 3. VOLTAGE
⊖ DC voltage (V) at no signal
 4. OTHERS:
⊕ Adjusting point.
The ⊕ mark found on some component parts is importance of the safety factor of the part. Therefore, be sure to use parts of identical designation.
- SWITCHES:
- S1: DOLBY NR ON - OFF
 - S2: TAPE SELECTOR METAL-NORM-CrO2
 - S3: MIC/LINE SELECTOR MIC - LINE
 - S4: PLAY ON - OFF
 - S5: STOP ON - OFF
 - S6: FF ON - OFF
 - S7: REW ON - OFF
 - S8: PAUSE ON - OFF
 - S9: REC ON - OFF
 - S10: ERASE PREVENT DETECTOR NO-HOLE
 - S11: POWER ON - OFF
 - S12: LINE VOLTAGE SELECTOR 220V - 240V

The underlined indicates the switch position.
This is the basic schematic diagram, but the actual circuit due to improvements in design.

Note;
Playback.
Recording

External Appearance of Transistors and ICs

2SA826LN
2SC1740LN

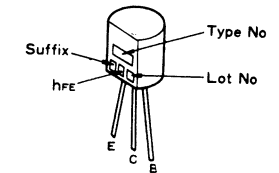

A

2SA1127
2SC2634

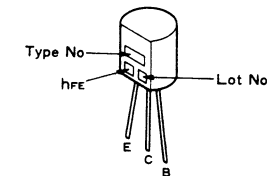

—

2SC2060

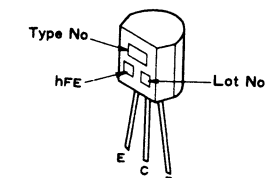

B

2SD837

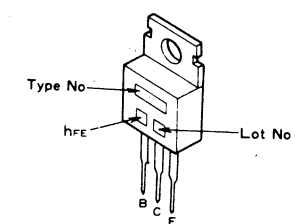

—

HA12005
HA12019
BA843

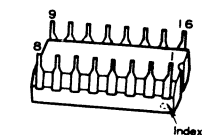

C

HA11226
HA12006

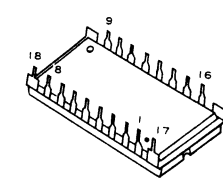

D

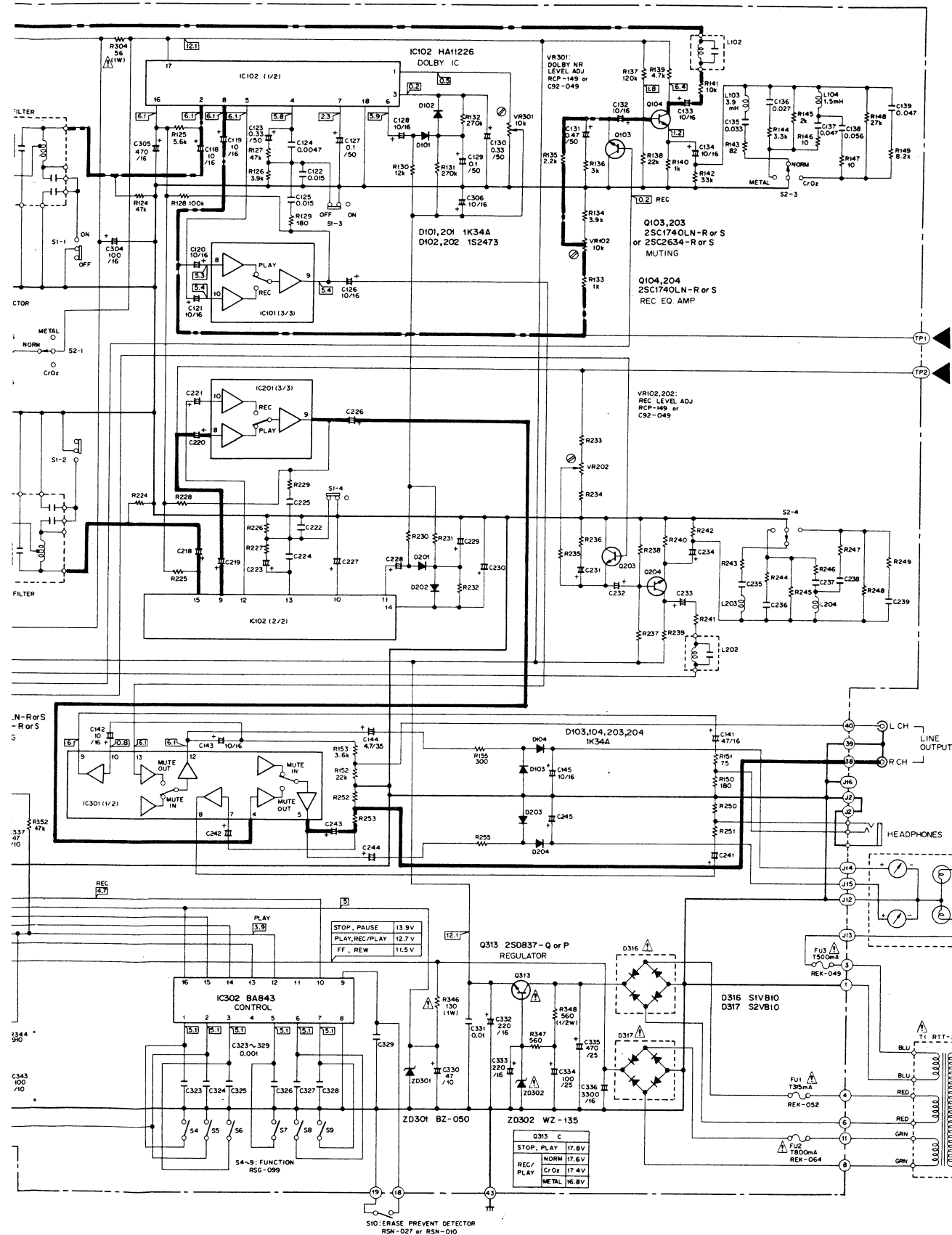

1. RESISTORS:
Indicated in Ω, kΩ, 5% tolerance unless otherwise noted k : kΩ,
M : MΩ, (F) : 1%, (G) : 2%, (K) : 10% tolerance
2. CAPACITORS:
Indicated in capacity (μF) voltage (V) unless otherwise noted p : pF
Indication without voltage : 50V except electrolytic capacitor.
3. VOLTAGE
⏏ DC voltage (V) at no load signal
4. OTHERS
⊗ Adjusting point.
⚠ The mark found on some component parts indicates the importance of the safety factor of the part. Therefore, when replacing, be sure to use parts of identical designation.
- SWITCHES:
S1 : DOLBY NR ON - OFF
S2 : TAPE SELECTOR METAL-NORM Cr-O2
S3 : MIC/LINE SELECTOR MIC - LINE
S4 : PLAY ON - OFF
S5 : STOP ON - OFF
S6 : FF ON - OFF
S7 : REW ON - OFF
S8 : PAUSE ON - OFF
S9 : REC ON - OFF
S10 : ERASE PREVENT DETECTOR NO-HOLE - HOLE
S11 : POWER ON - OFF
S12 : LINE VOLTAGE SELECTOR 220V - 240V
- The underlined indicates the switch position.

This is the basic schematic diagram, but the actual circuit may vary due to improvements in design.

Note;
Playback signal route ———
Recording signal route - - -

10. P.C.BOARD CONNECTION DIAGRAM

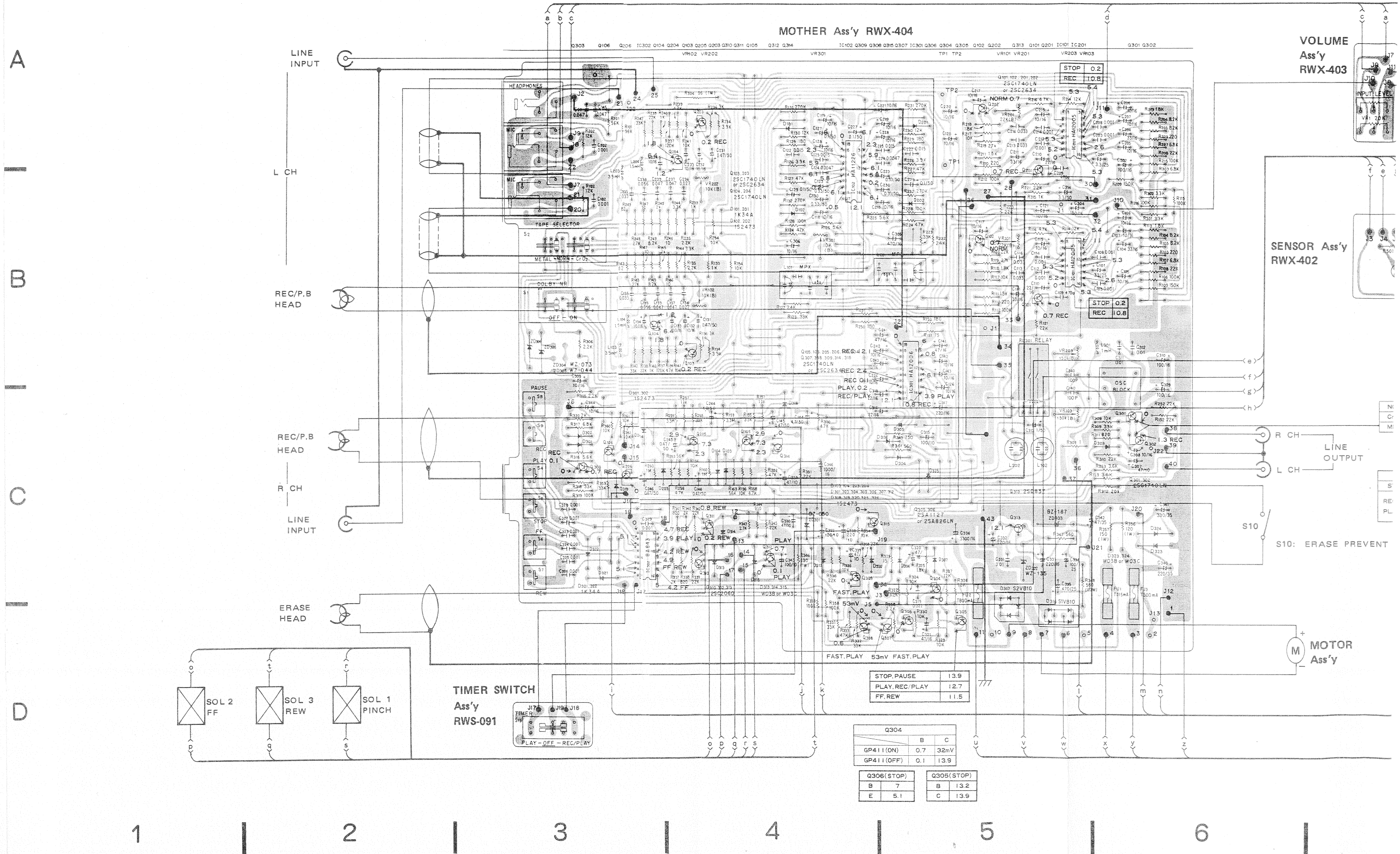

STOP, PAUSE	13.9
PLAY, REC/PLAY	12.7
FF, REW	11.5

Q304		
GP411 (ON)	0.7	32mV
GP411 (OFF)	0.1	13.9

Q306 (STOP)		Q305 (STOP)	
B	7	B	13.2
E	5.1	C	13.9

VOLUME Ass'y RWX-403

SENSOR Ass'y RWX-402

LINE OUTPUT
R CH
L CH

S10: ERASE PREVENT

MOTOR Ass'y

TIMER SWITCH Ass'y RWS-091

SOL 2 FF
SOL 3 REW
SOL 1 PINCH

A

B

C

D

1

2

3

4

5

6

1

2

3

4

5

6

4

5

6

7

8

9

MOTHER Ass'y RWX-404

VOLUME Ass'y RWX-403

SENSOR Ass'y RWX-402

FL METER Ass'y RWX-405

R CH
L CH
LINE OUTPUT

NORM	0.8
CrO ₂	0.9
METAL	1.4

Q313 C	
STOP, PLAY	17.8
NORM	17.6
CrO ₂	17.4
METAL	16.8

S10: ERASE PREVENT DETECTOR

M MOTOR Ass'y

S12: LINE VOLTAGE SELECTOR
S11: POWER

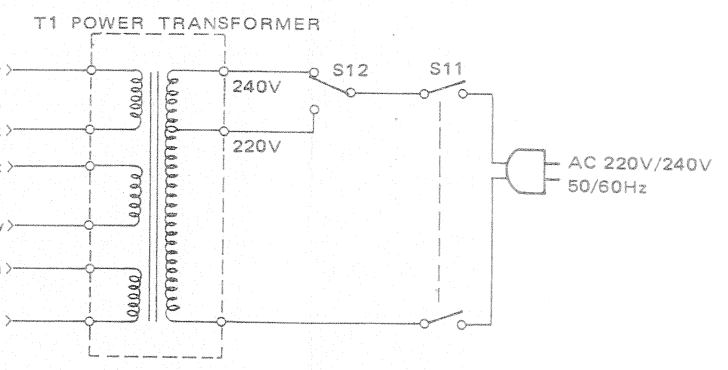

STOP, PAUSE		13.9	
PLAY, REC/PLAY		12.7	
FF, REW		11.5	

Q304		B		C	
GP411 (ON)	0.7	32mV			
GP411 (OFF)	0.1	13.9			

Q306 (STOP)		Q305 (STOP)	
B	7	B	13.2
E	5.1	C	13.9

A

B

C

D

4

5

6

7

8

9

11. PARTS LIST

NOTES:

• When ordering resistors, first convert resistance values into code form as shown in the following examples.

Ex. 1 When there are 2 effective digits (any digit apart from 0), such as 560 ohm and 47k ohm (tolerance is shown by J = 5%, and K = 10%).

560Ω — 56 × 10¹ — 561 RD¼PS 561J
 47kΩ — 47 × 10³ — 473 RD¼PS 473J
 0.5Ω — 0R5 RN2H 0R5K
 1Ω — 010 RS1P 010K

Ex. 2 When there are 3 effective digits (such as in high precision metal film resistors).

5.62kΩ 562 × 10¹ 5621 RN¼SR 5621F

• The Δ mark found on some component parts indicates the importance of the safety factor of the part. Therefore, when replacing, be sure to use parts of identical designation.

**Miscellaneous Parts List
P.C. BOARD ASSEMBLIES**

Part No.	Symbol & Description
RWX-404	Mother assembly
RWX-402	Sensor assembly
RWX-403	Volume assembly
RWX-405	F.L. assembly
RWS-091	Timer-switch assembly

SWITCHES

Part No.	Symbol & Description
Δ RSA-042	S11 Power switch
Δ RSX-045	S12 Line voltage selector (switchable 2 positions)

Mother Assembly (RWX-404)

SWITCHES AND JACKS

Part No.	Symbol & Description
RSK-063	S1 Lever switch B (DOLBY NR)
RSK-062	S2 Lever switch A (TAPE SELECTOR)
RKN-059	S3 Mic Jack
RSG-099	S4-S9 Push switch
RKN-060	Headphones jack

COILS FILTER AND RELAY

Part No.	Symbol & Description
RTX-007	OSC block
RSR-035	RL301 Lead relay
RFT-083	L101, L201 MPX filter block
RTF-084	L102, L202 Trap coil
RTF-085	L103, L203 Peaking coil (3.9mH)
RTF-086	L104, L204 Peaking coil (1.5mH)
RTF-057	L301 Line coil

OTHERS

Part No.	Symbol & Description
Δ RTT-214	T1 Power transformer
Δ RDG-033	Power cord (for HE type)
Δ RDG-032	Power cord (for HB type)
Δ RDG-029	Power cord (for HP type)
Δ REC-272	Strain relief
RXX-291	Front panel assembly

CAPACITORS

Part No.	Symbol & Description
CEANL 3R3M 25	C101,C201
CEANL 220M 16	C110,C210
CEAH 0R10M 50	C127,C129,C227,C229
CEAH 0R33M 50	C123,C130,C223,C230
CEAH 0R47M 50	C131,C145,C146,C231,C245,C246
CEAH 3R3M 50	C314
CEAH 010M 50	C313
CEA 331M 35	C341
CEA 471M 25	C335
CEAH 101M 25	C334
CEA 332M 16	C336
CEA 471M 16	C305
CEAH 221M 16	C317,C332,C333
CEAH 101M 16	C302,C304,C309,C310
CEAH 470M 16	C141,C241,C320-C322
CEAH 330M 16	C104,C111,C204,C211,C307

Part No.	Symbol & Description
CEAH 220M 16	C316,C318
CEAH 100M 16	C105-C107, C115, C117-C121, C126, C128, C132-C134, C142, C143, C205-C207, C215, C217-C221, C226, C228, C232-C234, C242, C243, C303, C306, C308, C344
CEAH 470M 10	C330,C337,C339
CEAH 221M 10	C338
CEAH 101M 10	C315,C343
CEA 221M 35	C340
CEAH 470M 35	C342
CEAH 4R7M 35	C144,C244
CQMAH 563J 50	C138,C238
CQMAH 473J 50	C137,C139,C237,C239
CQMAH 333J 50	C135,C235
CQMAH 273J 50	C136,C236
CQMAH 153K 50	C122,C125,C222,C225
CQMAH 472K 50	C124,C224
CQMAH 102K 50	C102,C103,C108,C112,C114,C202,C203, C208,C212,C214
CQMAH 333K 50	C113,C116,C213,C216
CQMAH 223K 50	C319
CKDYF 473Z 50	C301
CKDHYF 103Z 50	C311,C312,C331
CKDHYF 102Z 50	C323-C329
CQSA 101K 250	C140,C240
REC-018	C109,C209

Note: When ordering resistors, convert the resistance value into code form, and then rewrite the part no. as before.

RESISTORS

Part No.	Symbol & Description
RCP-150 (C92-857)	VR101,VR201 Semi-fixed 22k-B
RCP-149 (C92-049)	VR102,VR202,VR301 Semi-fixed 10k-B
RCP-155 (C92-860)	VR103,VR203 Semi-fixed 100k-B
Δ RS1PF□□□J	R304,R346,R357
RS1PF□□□J	R314,R356
RD¼PSF□□□J	R313,R348
RD¼PM□□□J	R101-R161, R163, R201-R261, R263, R301-R303, R305-R312, R315-R320, R335-R345, R347, R349-R355, R358-R360, R322-R333

SEMICONDUCTORS

Part No.	Symbol & Description
HA12005	IC101,IC201
HA11226	IC102
HA12006	IC301
BA843	IC302

Part No.	Symbol & Description
2SC1740LN (2SC2634)	Q101-Q103, Q105, Q106, Q201-Q203, Q205, Q206, Q303, Q304, Q307-Q309, Q314, Q315
2SC1740LN 2SA826LN (2SA1127)	Q104,Q204,Q301,Q302 Q305, Q306
Δ 2SC2060	Q310-Q312
Δ 2SD837	Q313
BZ-050	ZD301
Δ WZ-135	ZD302
BZ-187	ZD303
1K34A	D101, D201, D321, D322
1S2473	D102-D104, D202-D204, D301-D307, D312, D318-D320
Δ W03B (W03C)	D313-D315, D323, D324
Δ S1VB10	D316
Δ S2VB10F	D317

OTHERS

Part No.	Symbol & Description
Δ REK-052	FU1 Fuse T315mA
Δ REK-064	FU2 Fuse T800mA
Δ REK-049	FU3 Fuse T500mA
RBF-041	Tube

Timer Switch Assembly (RWS-091)

Part No.	Symbol & Description
RSH-051	S13 Slide switch (TIMER START)

Sensor Assembly (RWX-402)

Part No.	Symbol & Description
RD¼PM102J	R501
GP-411B	Photo interruptor
SLB15UR8	D501

Volume Assembly (RWX-403)

Part No.	Symbol & Description
RCV-085 (RCV-086)	VR1 Variable resistor (INPUT)

F.L. Meter Assembly (RWX-405)

Part No.	Symbol & Description
CKDYF 103Z 50	C401,C402
HA12019	IC401,IC402
BG-30ZYR	F.L. Meter

Part No.	Symbol & Description
CEAH 220M 16	C316,C318
CEAH 100M 16	C105-C107, C115, C117-C121, C126, C128, C132-C134, C142, C143, C205-C207, C215, C217-C221, C226, C228, C232-C234, C242, C243, C303, C306, C308, C344
CEAH 470M 10	C330,C337,C339
CEAH 221M 10	C338
CEAH 101M 10	C315,C343
CEA 221M 35	C340
CEAH 470M 35	C342
CEAH 4R7M 35	C144,C244
CQMAH 563J 50	C138,C238
CQMAH 473J 50	C137,C139,C237,C239
CQMAH 333J 50	C135,C235
CQMAH 273J 50	C136,C236
CQMAH 153K 50	C122,C125,C222,C225
CQMAH 472K 50	C124,C224
CQMAH 102K 50	C102,C103,C108,C112,C114,C202,C203, C208,C212,C214
CQMAH 333K 50	C113,C116,C213,C216
CQMAH 223K 50	C319
CKDYF 473Z 50	C301
CKDHYF 103Z 50	C311,C312,C331
CKDHYF 102Z 50	C323-C329
COSA 101K 250	C140,C240
REC-018	C109,C209

Note: When ordering resistors, convert the resistance value into code form, and then rewrite the part no. as before.

RESISTORS

Part No.	Symbol & Description
RCP-150 (C92-857)	VR101,VR201 Semi-fixed 22k-B
RCP-149 (C92-049)	VR102,VR202,VR301 Semi-fixed 10k-B
RCP-155 (C92-860)	VR103,VR203 Semi-fixed 100k-B
△RS1PF□□□J	R304,R346,R357
RS1PF□□□J	R314,R356
RD½PSF□□□J	R313,R348
RD¼PM□□□J	R101-R161, R163, R201-R261, R263, R301-R303, R305-R312, R315-R320, R335-R345, R347, R349-R355, R358-R360, R322-R333

SEMICONDUCTORS

Part No.	Symbol & Description
HA12005	IC101,IC201
HA11226	IC102
HA12006	IC301
BA843	IC302

Part No.	Symbol & Description
2SC1740LN (2SC2634)	Q101-Q103, Q105, Q106, Q201-Q203, Q205, Q206, Q303, Q304, Q307-Q309, Q314, Q315
2SC1740LN	Q104,Q204,Q301,Q302
2SA826LN (2SA1127)	Q305, Q306
△2SC2060	Q310-Q312
△2SD837	Q313
BZ-050	ZD301
△WZ-135	ZD302
BZ-187	ZD303
1K34A	D101, D201, D321, D322
1S2473	D102-D104, D202-D204, D301-D307, D312, D318-D320
△W03B (W03C)	D313-D315, D323, D324
△S1VB10	D316
△S2VB10F	D317

OTHERS

Part No.	Symbol & Description
△REK-052	FU1 Fuse T315mA
△REK-064	FU2 Fuse T800mA
△REK-049	FU3 Fuse T500mA
RBF-041	Tube

Timer Switch Assembly (RWS-091)

Part No.	Symbol & Description
RSH-051	S13 Slide switch (TIMER START)

Sensor Assembly (RWX-402)

Part No.	Symbol & Description
RD¼PM102J	R501
GP-411B	Photo interruptor
SLB15UR8	D501

Volume Assembly (RWX-403)

Part No.	Symbol & Description
RCV-085 (RCV-086)	VR1 Variable resistor (INPUT)

F.L. Meter Assembly (RWX-405)

Part No.	Symbol & Description
CKDYF 103Z 50	C401,C402
HA12019	IC401,IC402
BG-30ZYR	F.L. Meter

12. EXPLODED VIEWS

NOTES:

- Parts without part number cannot be supplied.
- The △ mark found on some component parts indicates the importance of the safety factor of the part. Therefore, when replacing, be sure to use parts of identical designation.

Parts List

Key No.	Part No.	Description	Key No.	Part No.	Description
1.	RNA-509	Bonnet	41.	BG-30ZYR	F.L. meter
2.		Mechanism assembly	42.		Meter holder R
3.	RWS-091	Timer-switch assembly	43.	
4.		Sub panel stay	44.		F.L. meter p.c.b.
5.	RAC-133	Knob (TIMER START)	45.	RWX-403	Volume assembly
6.	RAC-124	Lever knob A (POWER)	46.		Panel stay
△7.	RSA-042	Power switch	47.	RAC-124	Lever knob A (DOLBY NR)
8.	RAW-141	Counter	48.	RAC-125	Lever knob B(TAPE SELECTOR)
9.	RWX-402	Sensor assembly	49.		Rear panel
10.		Counter holder	50.	RWX-404	Mother assembly
11.	SLB15UR8	LED	△51.	REK-064	Fuse (T 800mA)
12.		Sensor p.c.b.	△52.	REK-049	Fuse (T 500mA)
13.	GP-411P	Photo interruptor	△53.	REK-052	Fuse (T 315mA)
14.	RNL-074	Meter lens	54.		Switch holder
15.	RNL-075	Front cover	55.	RSG-099	Push switch
16.	RNL-073	Escutcheon	56.	RSK-063	Lever switch (DOLBY NR)
17.	RBH-750	Eject spring	57.	RSK-062	Lever switch(TAPE SELECTOR)
18.		Eject plate	58.	RKN-059	MIC jack
19.	RAC-132	Knob (EJECT)	59.	RKN-060	Headphones jack
20.	RXX-291	Front panel assembly	60.		Mother p.c.b.
21.	RNL-078	Knob guide	61.		P.C.B holder
22.		Front panel	62.	RDE-046	Pin cord B (OUTPUT)
23.	RNL-076	Escutcheon S	63.	RDE-045	Pin cord A (INPUT)
24.	RNL-082	Knob holder	64.		Side frame
25.	RAC-131	Control knob	65.		Bottom plate
26.	RNL-077	Escutcheon W	66.	REC-355	Sliding stopper
27.	RBH-751	Earth spring	67.	ATZ40P080FZK	Screw
28.	RAA-344	Knob A (INPUT L)	68.	VCZ30P060FMC	Screw
29.	ARR-345	Knob B (INPUT R)	69.	PMA26P060FMC	Screw
△30.	RTT-214	Power transformer	70.	PMA30P060FMC	Screw
31.		UL cord clasper	71.	CMZ30P060FMC	Screw
32.		Chassis	72.	PBZ30P120FMC	Screw
33.	REC-356	Foot	73.	PBZ26P060FMC	Screw
△34.	RSX-045	Line voltage selector	74.	CBZ26P060FMC	Screw
△35.	REC-272	Strain relief	75.	VCT30P060FZK	Screw
△36.	RDG-033	Power cord (for HE type)	76.	CTZ26P060FMC	Screw
	RDG-032	Power cord (for HB type)	77.	VBZ40P160FMC	Screw
	RDG-029	Power cord (for HP type)	78.	VCZ30P060FZK	Screw
37.		Terminal (GND)	79.	VBZ30P080FZK	Screw
38.		Bottom cover	80.	WA30W100R100	Washer
39.	RWX-405	F.L. meter assembly	81.	VCZ30P100FMC	Screw
40.		Meter holder			

1

2

3

4

5

6

A

B

C

D

A

B

C

D

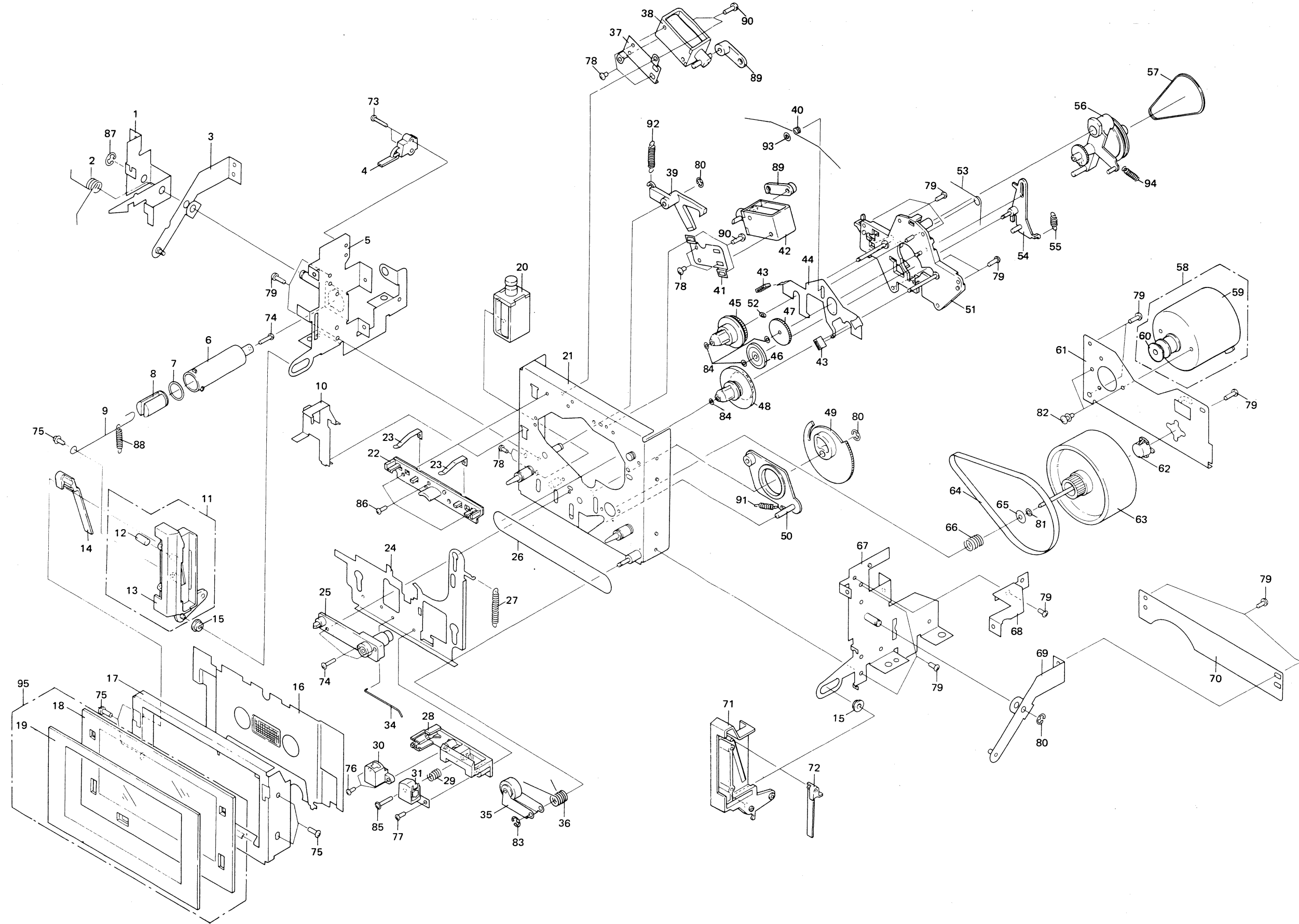

1

2

3

4

5

6

Parts List

Key No.	Part No.	Description	Key No.	Part No.	Description
1.		Eject lever	51.	RXB-378	Reel base assembly
2.	RBH-743	Eject lever spring	52.	WA21D040D025	Washer
3.		Side arm L assembly	53.	RBH-725	FR spring
4.	RSN-027	Lever switch	54.	RXB-374	Idler arm assembly
5.		Side plate L assembly	55.	RBH-724	Idler pressure spring
6.	RNK-995	Cylinder	56.	RXB-376	Driving arm full assembly
7.	REB-323	O ring	57.	REB-413	Drive belt
8.	RNL-053	Piston	58.	RXM-076	Motor assembly
9.	RBH-726	Connection rod	59.		Motor
10.		REC prevent lever	60.		Motor pulley
11.	RXB-405	Pocket L assembly	61.		Flywheel holder
12.		Bush	62.		Thrust receptacle
13.		Pocket L	63.	RXB-358	Flywheel assembly
14.	RNL-057	Pocket spring L	64.	REB-411	Capstan belt
15.	RNK-994	Guide roller	65.	RBF-050	Oil stop washer
16.	RAH-347	Cassete plate	66.	RBH-721	Flywheel spring
17.		Pocket frame	67.		Side plate R assembly
18.		Door	68.		Mounting plate
19.		Door panel	69.		Side arm R assembly
△ 20.	RXP-092	Solenoid P	70.		Connection plate
21.		Chassis assembly	71.	RNL-049	Pocket R
22.	RNL-042	Half receptacle	72.	RNL-058	Pocket spring R
23.	RNF-895	Half spring	73.	PMZ20P080FMC	Screw
24.		Head base	74.	VCZ26P090FMC	Screw
25.	RXB-359	Bearing holder assembly	75.	ATZ26P060FZK	Screw
26.	REB-417	Counter belt	76.	PMZ20P130FMC	Screw
27.	RBH-741	HB return spring	77.	PMZ20P120FMC	Screw
28.	RNL-050	Sub head base	78.	PMZ26P030FMC	Screw
29.	RBH-723	Head adjust spring	79.	VCZ26P060MFC	Screw
30.	RPB-085	Erase head	80.	YE30FUC	Washer
31.	RPB-084	REC/PB head	81.	WA21D040D25	Washer
32.		82.	PMA26P040FMC	Screw
33.		83.	YE20FUC	Washer
34.	RBH-759	HB drive spring	84.	WA17D032D025	Washer
35.	RXB-414	Pinch arm assembly	85.	IMZ20Y120FMC	Screw
36.	RBH-742	Pinch pressure spring	86.	PCZ26P060FMC	Screw
37.		Solenoid bracket L	87.	YE40FUC	Washer
△ 38.	RXP-094	Solenoid R	88.	RBH-761	Earth spring
39.	RNL-051	Gear lever	89.	RNL-047	Solenoid arm
40.	RBH-727	Brake spring	90.	PMZ26P060FMC	Screw
41.		Solenoid bracket R	91.	RBH-744	Lever spring
△ 42.	RXP-093	Solenoid F	92.	RBH-722	Gear lever spring
43.	REB-187	Brake shoe	93.	YS20FBT	Washer
44.		Brake plate	94.	RBH-758	FF spring
45.	RXB-377	Supply reel base assembly	95.	RXX-290	Door assembly
46.	RNK-999	TU idler			
47.	RNK-998	Idler gear			
48.	RXB-360	TU reel base assembly			
49.	RNL-059	Cam gear			
50.	RXB-387	Lever assembly			

13. PACKING

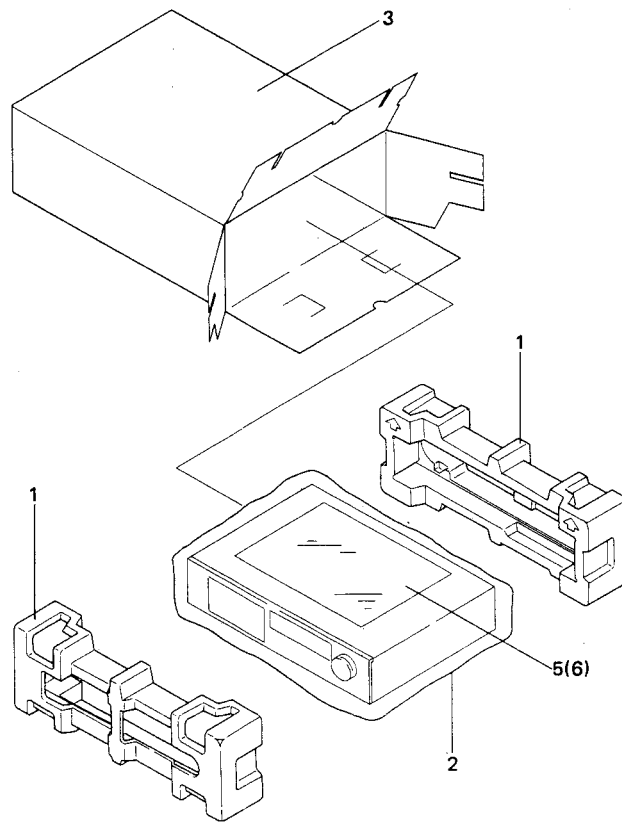

Parts List

Key No.	Part No.	Description
1.	RHA-220	Pad
2.	RHX-031	Sheet C
3.	RHG-360	Packing case
4.	
5.	RRB-136	Operating instructions (English)
(6).	RRD-046	*Operating instructions (German/ French)

*
The operating instructions (German/French) is provided with HE type only.