

ADDITIONAL

 **PIONEER**
The Art of Entertainment

Service Manual

ORDER NO.
CRT1428

CASSETTE MECHANISM ASSEMBLY

CX-197

NOTE

- This service manual describes operation of the cassette mechanism incorporated in models listed in the table below.
- When performing repairs use this manual together with the specific manual for the model under repair.
- CX197 (CRT1328) does not have a Key-off function, but the key-off function is shown in this service manual of the CX-197 (CRT1428).

Model	Service Manual	Cassette Mechanism Assembly
KEH-M7400RDS/EW	CRT1429	EXK1735

Model	Service Manual	Cassette Mechanism Assembly

PIONEER ELECTRONIC CORPORATION 4-1, Meguro 1-Chome, Meguro-ku, Tokyo 153, Japan
PIONEER ELECTRONICS SERVICE INC. P.O. Box 1760, Long Beach, California 90801 U.S.A.
PIONEER ELECTRONICS OF CANADA, INC. 505 Cochrane Drive, Markham, Ontario L3R 8E3 Canada
PIONEER ELECTRONIC [EUROPE] N.V. Haven 1087 Keetberglaan 1, 9120 Melsele, Belgium
PIONEER ELECTRONICS AUSTRALIA PTY. LTD. 178-184 Boundary Road, Braeside, Victoria 3195, Australia TEL: [03] 580-9911

1. DISASSEMBLY

Note: Always use new washer and E washer at the time of reassembling.

● How to Remove the Belt and Motor

1. Remove screw A fixing the FR lever. (Fig.1)
2. Remove three screws B fixing the sub-chassis unit. Move the unit first in Direction A, then in B direction, and lift it upward for removal. (Fig.2)
3. The belt can now be removed. (Fig.3)
4. Remove two screws C. The motor can be removed. (Fig.3)

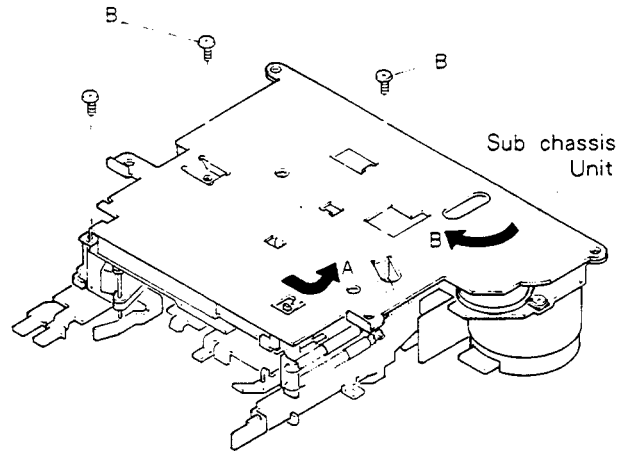

Fig. 2

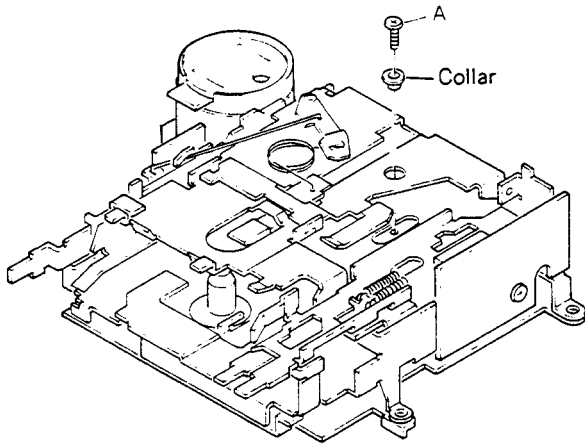

Fig. 1

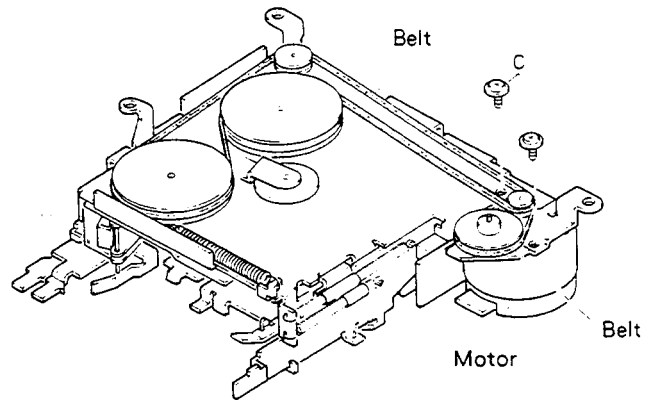
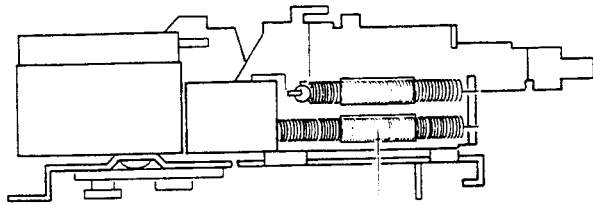

Fig. 3

● How to Remove the Pinch Roller Unit and Head



Spring A

Fig. 4

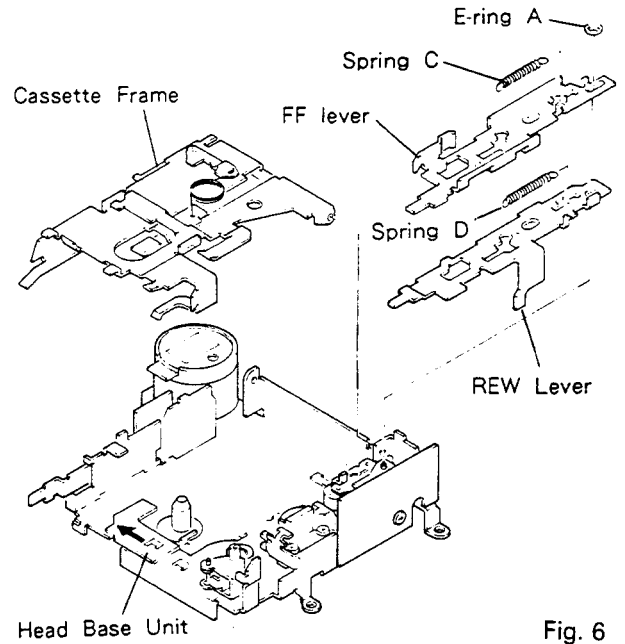

Head Base Unit

Fig. 6

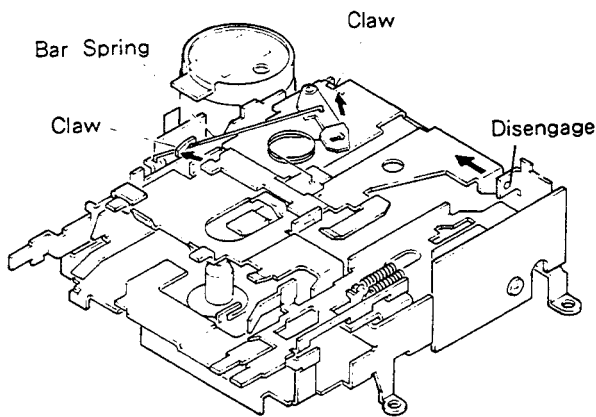

Fig. 5

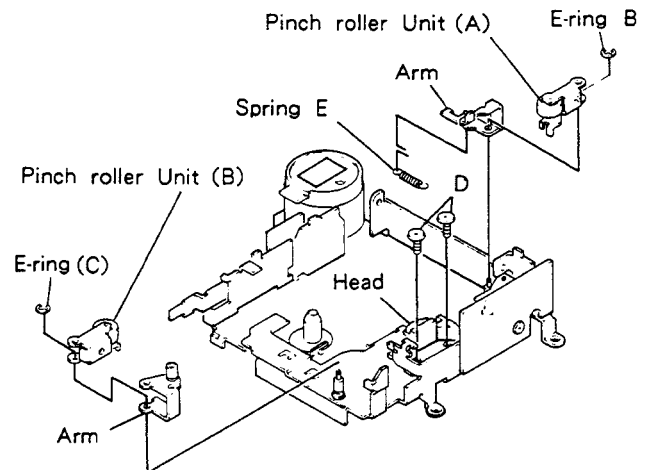

Fig. 7

1. Remove spring A. (Fig.4)
2. Extend claws (2 points). (Fig.5)
3. Remove bar Spring. (Fig.5)
4. Disengage projection by moving in a direction of arrow mark. (Fig.5)
5. The cassette frame is removed. (Fig.6)
6. Remove springs C and D. (Fig.6)
7. Remove E-ring A. (Fig.6)
8. Remove FF/REW levers. (Fig.6)

9. Move head base unit forward. (Fig.6)
10. Remove spring E. (Fig.7)
11. Remove E-ring B. The pinch roller unit (A) can be removed. (Fig.7)
12. Remove E-ring C. The pinch roller unit (B) can be removed. (Fig.7)
13. Remove two screws D. The head can be removed. (Fig.7)

2. ADJUSTMENT

2.1 CHECK POINTS OF CASSETTE MECHANISM

<p>Confirm the following items when replacing parts of the cassette mechanism.</p>	<p>■ Tape speed deviation: $3,000 \begin{smallmatrix} +90 \\ -30 \end{smallmatrix} \text{ Hz}$ $(4.76 \text{ cm/s} \begin{smallmatrix} +3 \\ -1 \end{smallmatrix} \%)$</p> <p>Using an NCT-111, measure the speed at the start and end of winding and take the maximum value. If values indicated by the pointer vary considerably, adjust to 70% of the minimum and maximum values. Measuring time shall be 5 – 6 seconds.</p>	<p>■ Wow and flutter: Less than 0.2% (WRMS)</p> <p>Using an NCT-111, measure the wow and flutter at the start and end of winding and take the maximum value. If values indicated by the pointer vary considerably, adjust to 70% of the minimum and maximum values. Measuring time shall be 5 – 6 seconds.</p>
<p>■ Fast forward and rewinding time: 100 – 120 seconds</p> <p>Using a C-60, set to fast forward and rewind, and measure the time with a stop watch.</p>	<p>■ Winding torque: 35 – 65g · cm</p> <p>Using a cassette type torque meter (100 g·cm), measure the minimum value while in the play mode. Measuring time shall be 2.5 – 6 seconds.</p>	<p>■ F.F. torque: 70 – 120g · cm</p> <p>Using a cassette type torque meter (120 g·cm), measure the value when the tape stops in the F.F. mode.</p>
<p>■ REW torque: 70 – 120g · cm</p> <p>Using a cassette type torque meter (120 g·cm), measure the value when the tape stops in the REW mode.</p>	<p>■ Back tension torque: 2 – 6g · cm</p> <p>After setting in the REW mode without loading a cassette tape for 5 minutes, measure the back tension torque in the play mode, using a cassette type torque meter.</p>	<p>■ Cassette loading force: Less than 0.7 kg</p> <p>Push the center of the cassette and measure the force with a tension meter (3 kg).</p>

2.2 AZIMUTH ADJUSTMENT

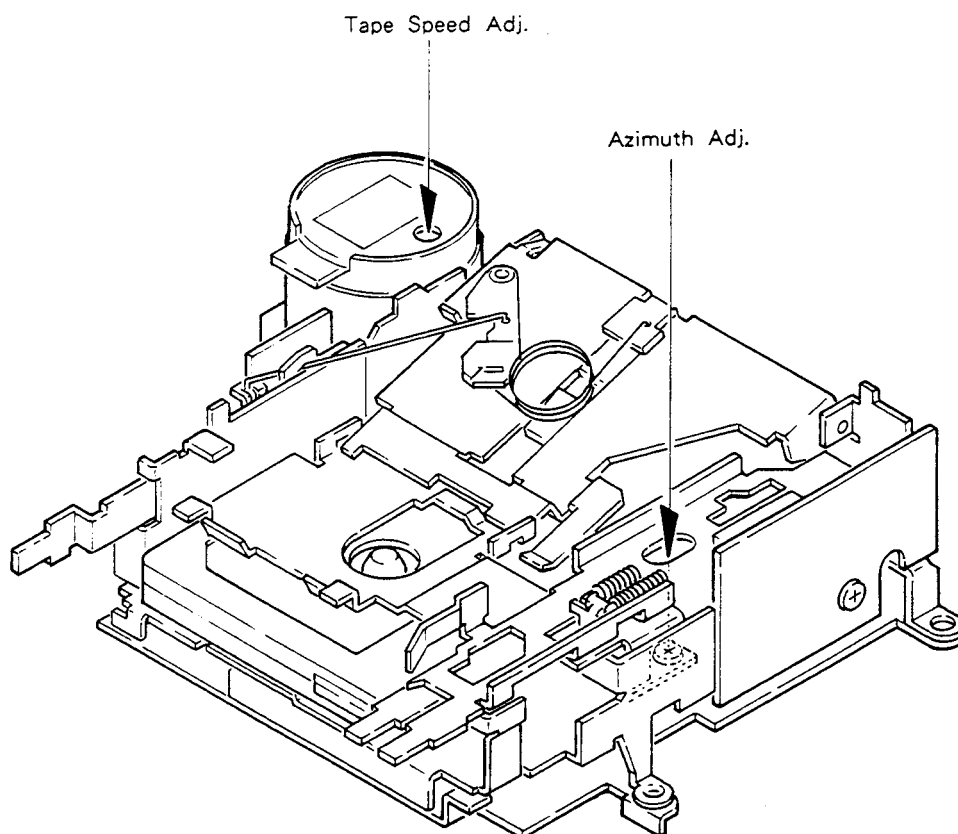

Fig. 8

● To Adjust (EXK1750)

1. Play "A" side of NCT-110 (10kHz, -10dB). Adjust the screw for maximum output in forward and reverse directions.
2. Play "B" side in forward and reverse directions to confirm adjustment.

2.3 TAPE SPEED ADJUSTMENT

1. Reproduce NCT-111 (3kHz, -10dB). Adjust the semifixed resistor so that frequency counter shows 3010Hz (+80Hz, -40Hz).

3. MECHANISM DESCRIPTION

● Loading operation

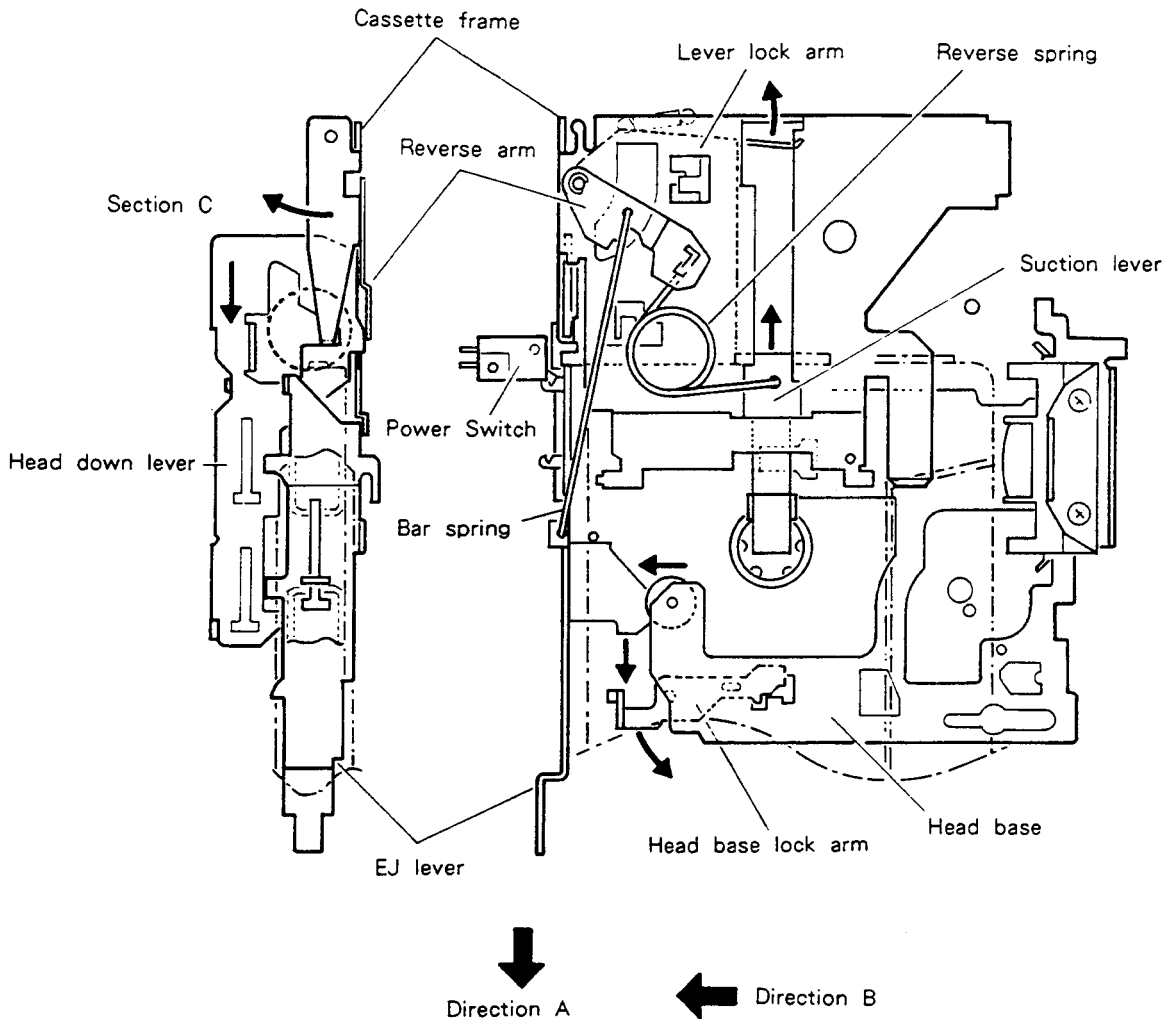

Fig. 9

1. A cassette tape, when inserted, pushes a suction lever.
The reverse spring rotates to move past the reverse point. Then, the cassette is drawn by a force of a reverse spring (suction operation).
2. After suction, the lever lock arm is pressed to be unlocked.
3. The head down lever is unlocked and the lever moves in Direction A.
4. While moving, the EJ lever turns ON the power switch.
5. The cassette frame engaged to the section C of the head down lever turns. (Cassette drop operation)
6. At the stroke end, the head down lever turns the head base lock arm.
7. A Stopper of the head base lock arm is released, and the head base moves forward (Direction B).

● MS Operation

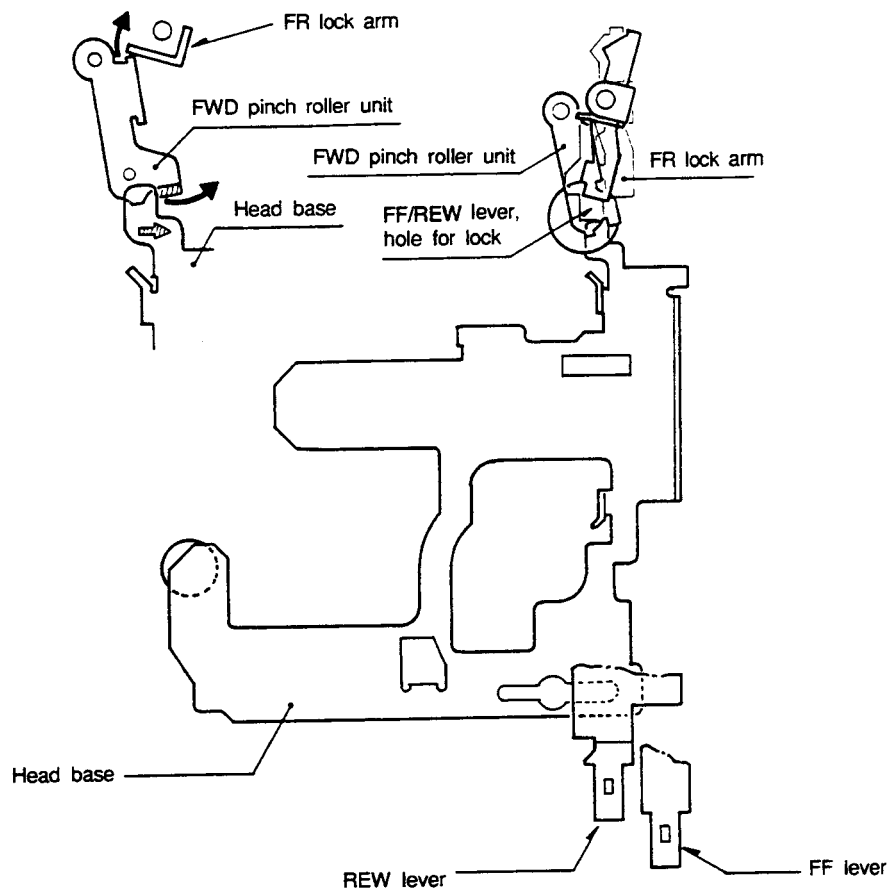

Fig. 10

The head base is moved back by switching the key-off solenoid off from the REW or FF condition, and is lowered (rotated) FWD pinch roller unit. The FWD pinch roller unit presses the bending part of FR lock arm to make it rotate in the direction that releases the lock. The lock of the FF/REW lever is consequently released.

Subsequently, the head comes out from the ATSC to enable PLAY condition.

● Direction Changeover Operation

(1) FWD play operation

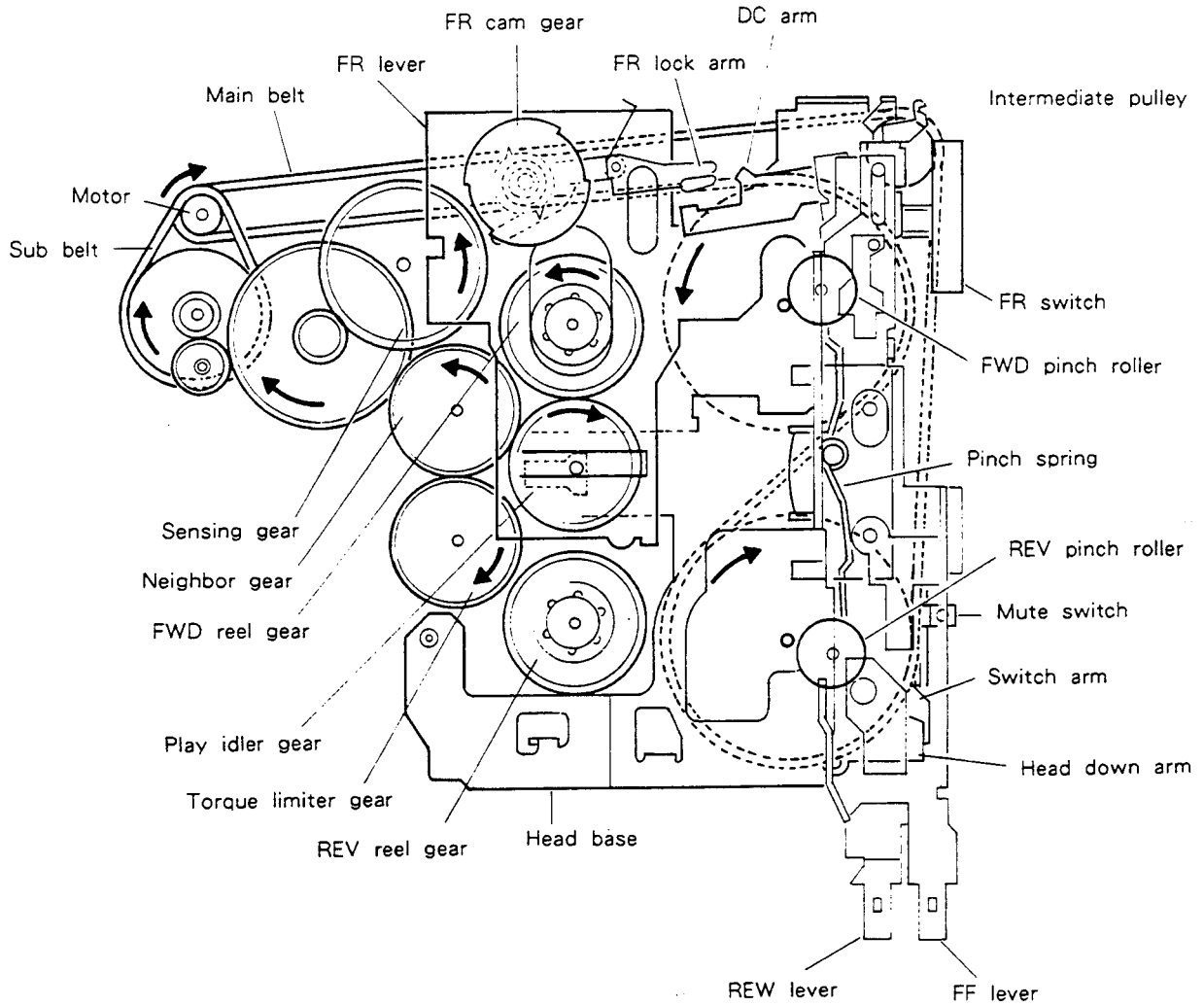

Fig. 11

When the FR lever is in the top position, the pinch spring is in the upper position to press the FWD pinch roller. The FR switch also moves upward and its reaction causes downward force on the FR lever. The spring attached to the FR lever applies upward force to the play idler gear from above to engage it with the neighbor gear and FWD reel gear.

The tape is driven in the FWD direction by a running motor and taken up by the REV reel gear via the torque limiter gear.

(2) Direction change operation

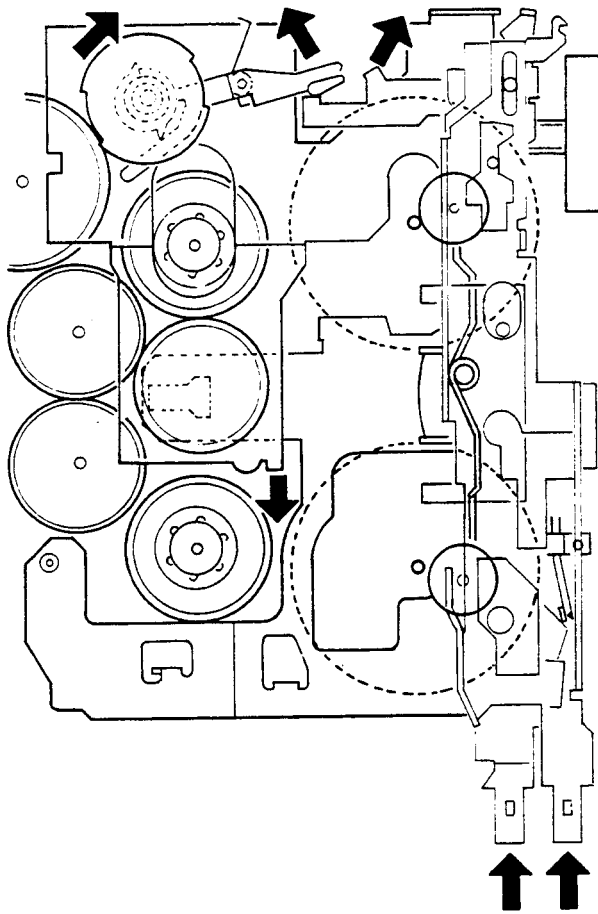

Fig. 12

The direction is changed by pressing FF and REW levers simultaneously. The DC arm turns along a cam groove of FF and REW levers to turn the FR lock arm. As the FR lever applies force from above downward, the FR cam gear turns and the notch meshes with the sensing gear.

As a result, the FR lever moves downward.

When FF and REW levers are kept pressed, the lock arm contacts the outside of the FR cam gear to prevent changeover between FWD and REV. Pressing FF and REW levers also cause the mute switch to be turned ON. In other words, muting is valid while FF and REW levers are pressed. (Fig.12)

(3) REV play operation

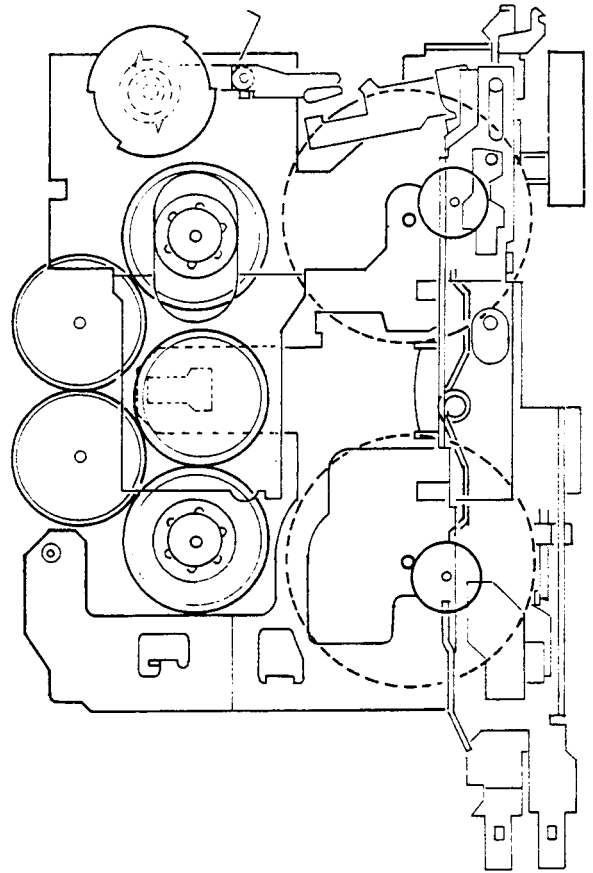

Fig. 13

Moving the NR lever up and down causes changeover among the pinch roller, FR switch, and play idler gear. With FF and REW levers having been returned, the FR lock arm returns to the normal lock position and locks the gear when the FR gear completes an one-half turn. The mute arm also returns to turn OFF the mute switch. The reverse play state is thus obtained. (The same applies to changeover from REV to FWD.)

● FF/REW Operation

(1) FWD play operation

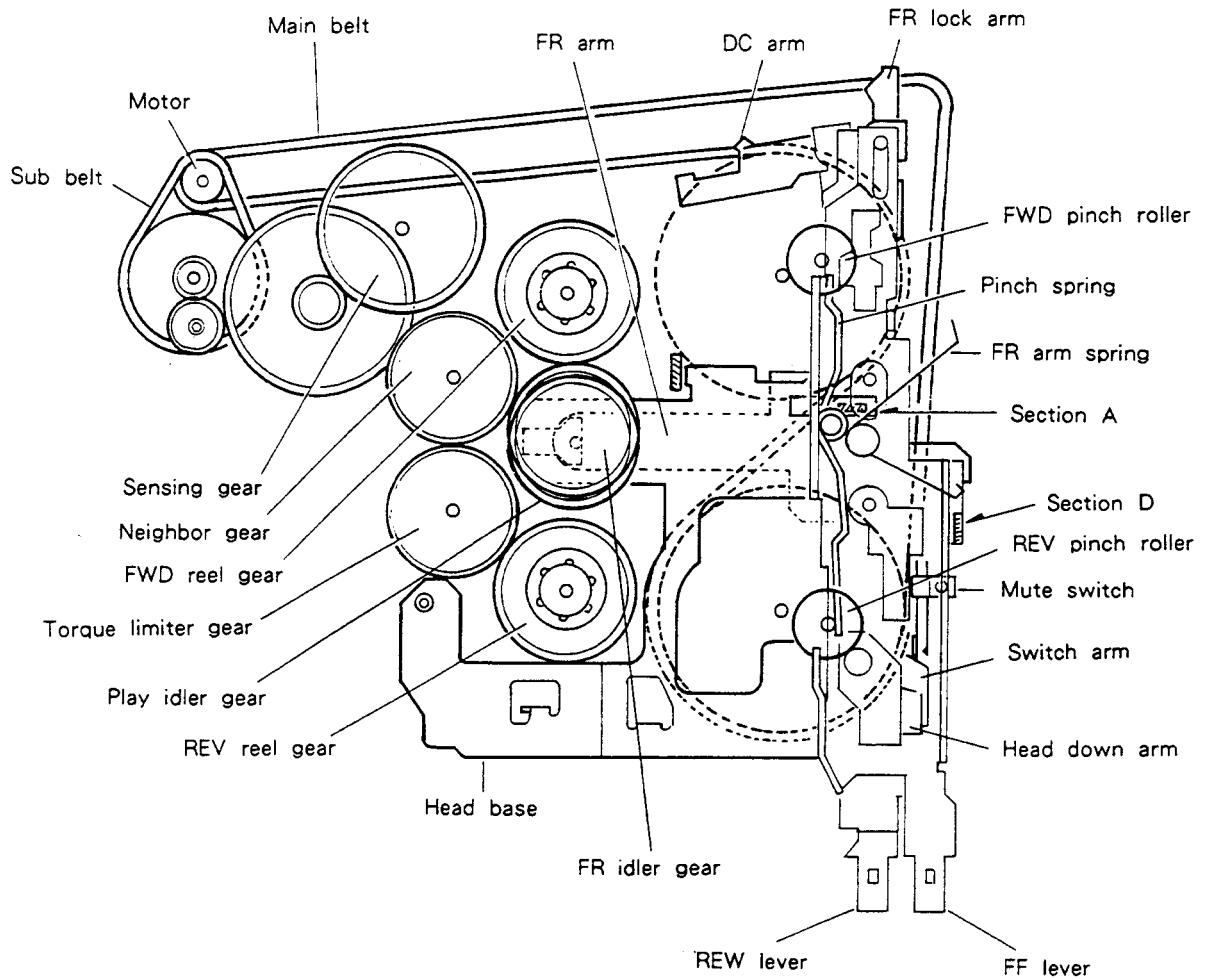

Fig. 14

In the FWD (REV) play state, the head base is fixed by a chassis stopper. The pinch spring presses the pinch roller into contact with a capstan to drive forward the tape. The REV reel gear takes up the tape via the torque limiter gear. In this case, the FR idler gear on the FR arm is centered by Section A of the head base and thus not rotating.

(2) FF Operation

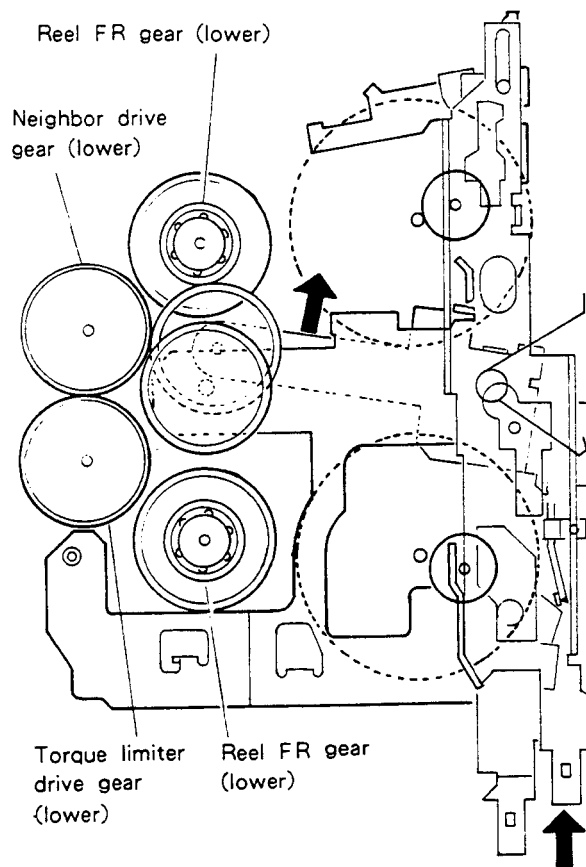

Fig. 15

FF operation is obtained by pressing and locking the FF lever. As the FF lever is pressed, the switch arm turns to turn ON the mute switch. The head base is moved backward along the FF lever cam groove.

As the head base moves backward to release the pinch roller from the capstan, the play idler gear is simultaneously disengaged from the reel gear. As the head base moves backward, the FR arm centered by Section A is put into rotation by the FR arm spring to engage with the FWD side FR gear.

The FF lever is locked by the FR lock arm and performs the FF operation. (Fig.15)

(3) REW operation

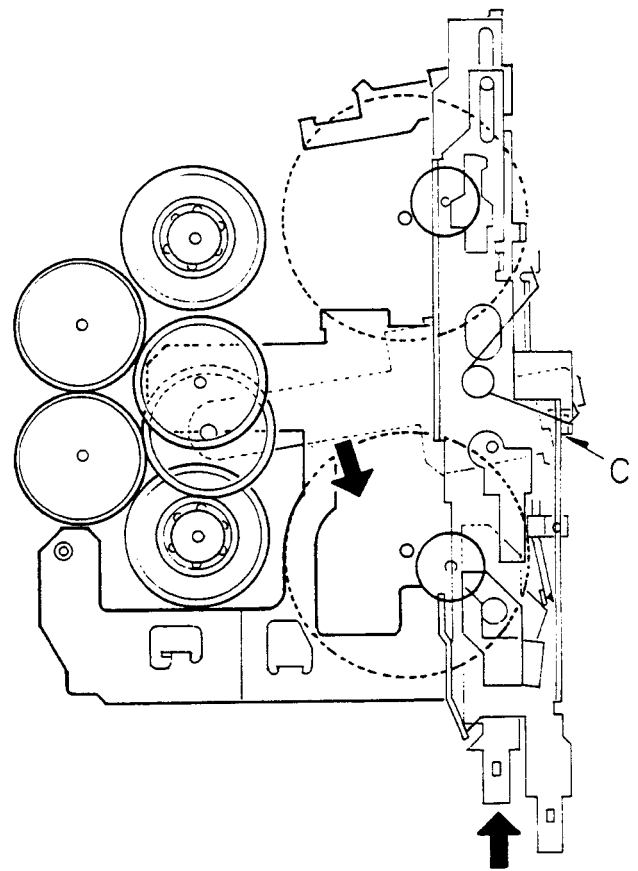

Fig. 16

Similar to the case of FF operation, pressing the REW lever causes the mute switch to be turned ON.

Simultaneously with release of the pinch roller from the capstan, the play idler gear is disengaged from the reel gear.

Section D of the REW lever presses a movable side of the FR arm spring, thereby engaging the FR gear to the FR gear on the REV side.

The REW lever is locked by the lock arm, performing the REW operation. This operation is cancelled when Section C is turned by the lever return spring. (Fig.16)

● Sensing Operation

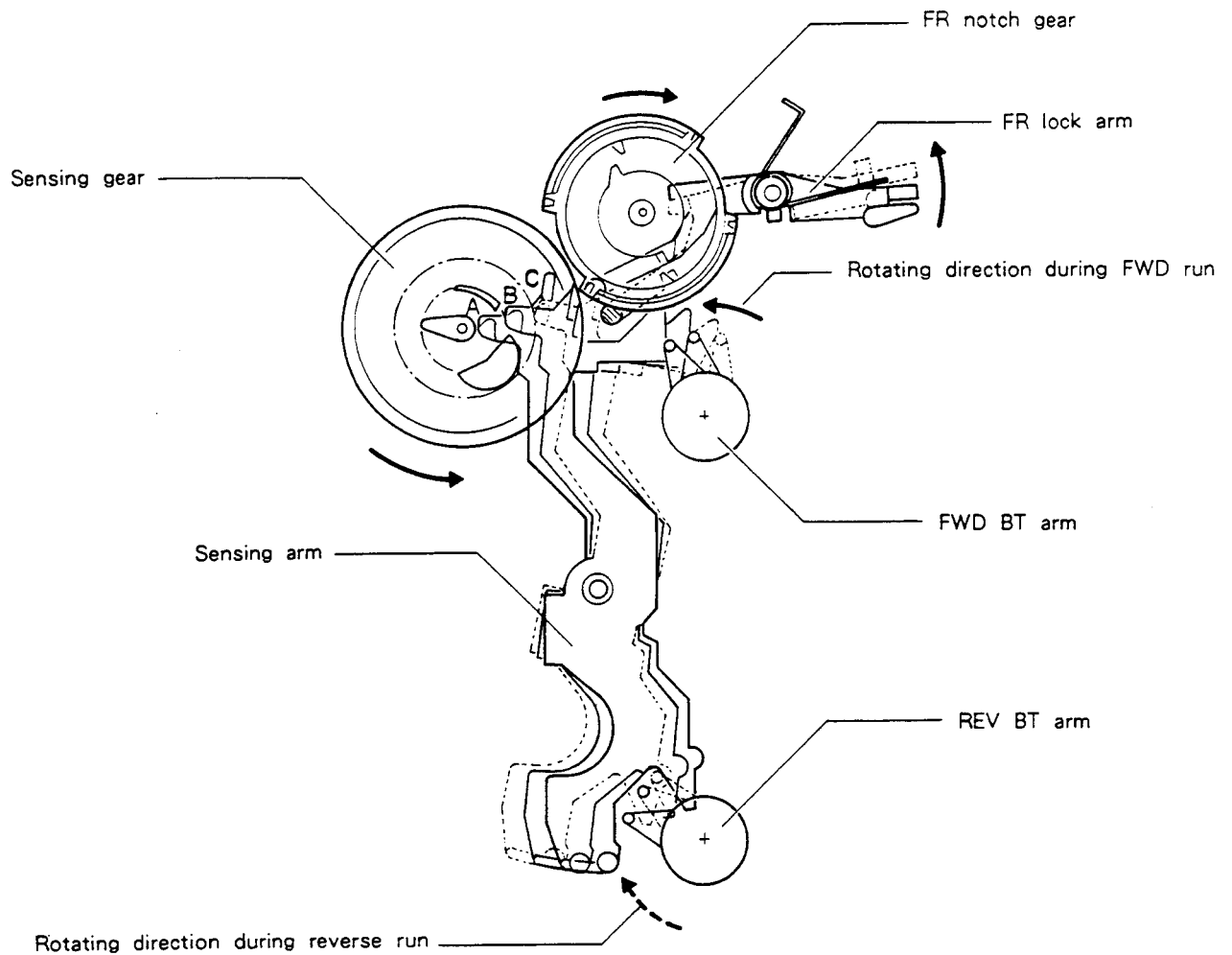

Fig. 17

1. During tape run: The sensing arm keeps oscillation between A and B under a force of the FWD BT arm (or REV BT arm).
2. At end of tape: The force of the BT arm is lost. The sensing arm stops at Position B, then pushed out to Position C by a crescent cam of the sensing gear.
3. Change of run direction: The FR lock arm turns counter-clockwise along with movement of the sensing arm. The FR notch gear is unlocked and begins to turn.

● ATSC Operation

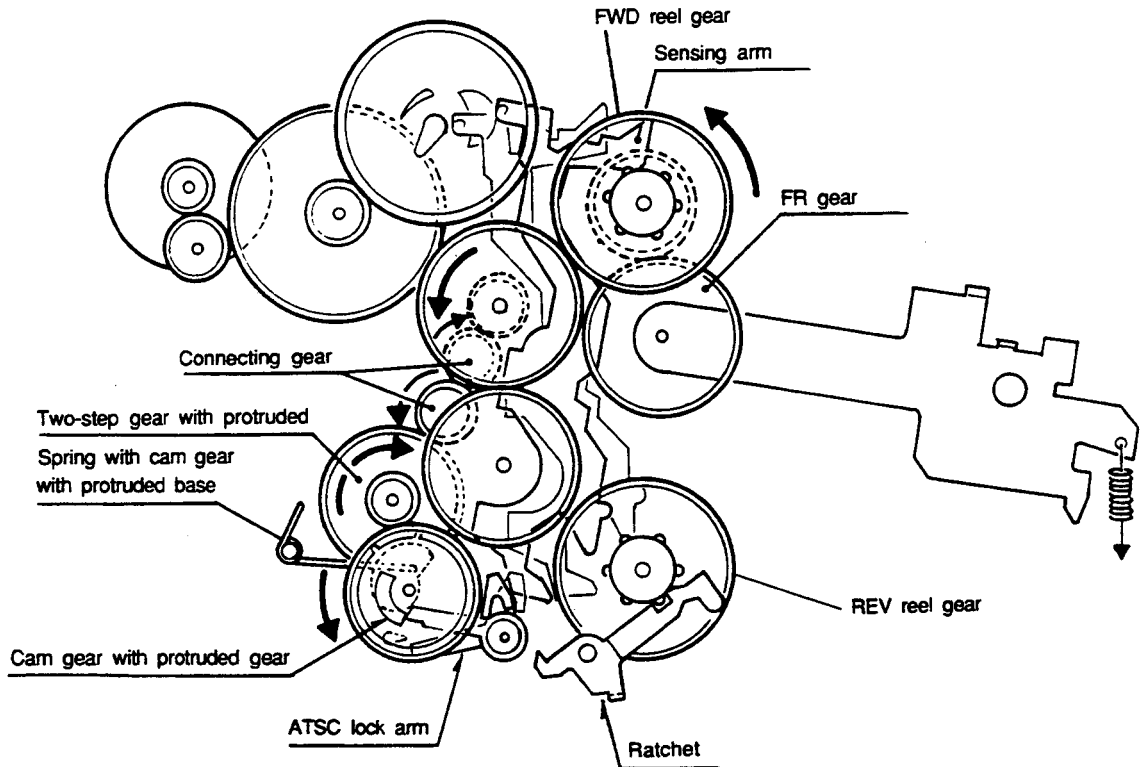
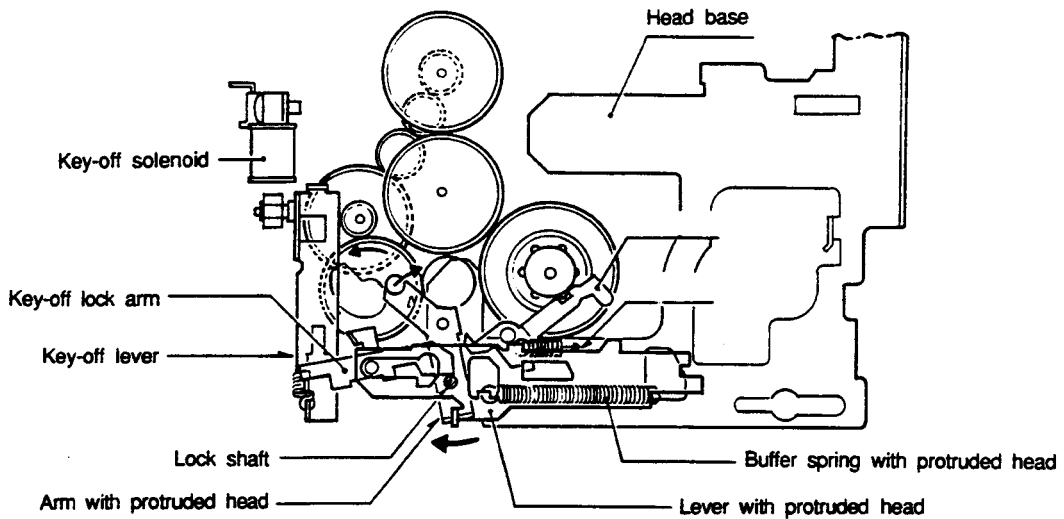

Fig. 18

1. At the position for releasing the head table, the FR gear is meshed with the FWD reel gear. Because the ratchet in the REV reel gear stops rotating, the tape must be wound up until no slack exist.
2. Because the rotation stops when no slack exists in the tape, sensing is performed. The sensing arm presses the ATSC lock arm, and the lock of the cam gear with protruded head gets out of position. Then, the cam gear is made to rotate.

● Key-off Operation

Release Condition



Play Condition

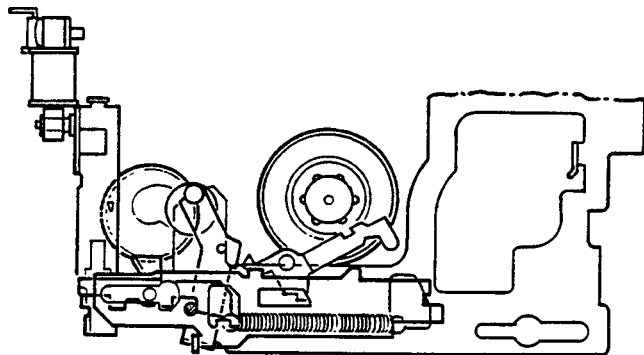

Fig. 19

1. Thrusting head: The arm with protruded head is rotated by the rotation of the cam gear with protruded head, and the lever with protruded head is pushed out. Because the lever with the protruded head and head base are connected by the buffer spring with protruded head, the head base moves forward.
2. Lock for head base: When the lever with protruded head moves forward, the lock shaft caulked by the lever with protruded head shifts. Thus, the key-off lock arm can rotate, and the key-off lever reaches the key-off solenoid

by force of a spring, and becomes attached. (Although escape power works on the key-off lock arm by force of the head return spring, the solenoid maintains it.)

3. Key-off: The key-off lock arm is rotated by the power of the head return spring when the key-off solenoid is switched off, and the lever with protruded head and head base move back together.

● EJECT Operation

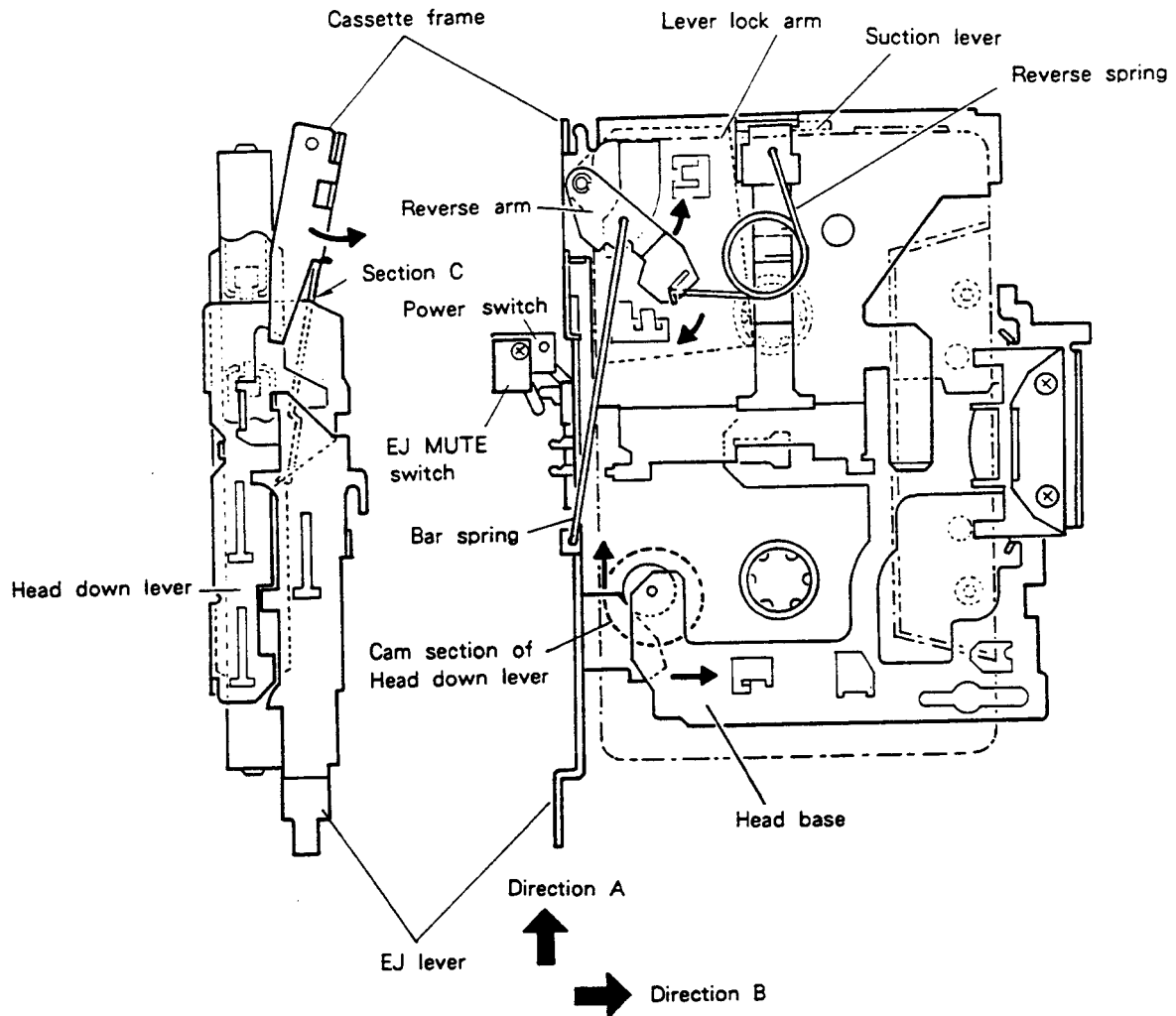

Fig. 20

1. Push the EJ lever in Direction A by hand (EJ MUTE SW ON) At the same time, the head down lever slides in Direction A.
2. The cam section of the head down lever returns the head base in Direction B (head base down operation).
3. Section C of the cassette frame is pushed up by the stroke of the head down lever (push-up operation).
4. The reverse arm is driven in a direction of arrow mark via bar spring by the EJ lever stroke.
5. The reverse spring passes through the reverse position to eject the cassette tape (eject operation).
6. With the EJ lever over-stroking, the lever lock arm can be rotated and locks the head down lever.
7. When released, the EJ lever returns and is stopped by the head down lever.