

Pioneer

Service Manual

ORDER NO.
CRT2356

CD MECHANISM MODULE

CX-892

- This service manual describes the operation of the CD mechanism incorporated in models listed in the table below.
- When performing repairs use this manual together with the specific manual for model under repair.

Model	Service Manual	CD Mechanism Module	Mechanism Unit
CDX-P650/X1N/UC,EW,ES	CRT2315	CXK4800	CXB3007
CDX-P656/X1N/UC	CRT2317	CXK4805	CXB3007
CDX-P25/X1N/EW		CXK4800	CXB3007
CDX-FM657/X1N/UC,EW,ES	CRT2316	CXK4815	CXB3007
CDX-FM653/X1N/UC	CRT2321	CXK4811	CXB3007

CONTENTS

1. CIRCUIT DESCRIPTIONS	2
2. DISASSEMBLY	18
3. MECHANISM DESCRIPTIONS.....	23

PIONEER ELECTRONIC CORPORATION 4-1, Meguro 1-Chome, Meguro-ku, Tokyo 153-8654, Japan
PIONEER ELECTRONICS SERVICE INC. P.O.Box 1760, Long Beach, CA 90801-1760 U.S.A.
PIONEER ELECTRONIC [EUROPE] N.V. Haven 1087 Keetberglaan 1, 9120 Melsele, Belgium
PIONEER ELECTRONICS ASIACENTRE PTE.LTD. 253 Alexandra Road, #04-01, Singapore 159936

1. CIRCUIT DESCRIPTIONS

The LSI (UPD63710GC) used on this unit comprises five main blocks ; the pre-amp section, servo, signal processor, DAC and CD text decoder (not used on this model). It also equips with nine automatic adjustment functions.

1.1 PRE-AMP SECTION

This section processes the pickup output signals to create the signals for the servo, demodulator and control.

The pickup output signals are I-V converted by the pre-amp with the built-in photo-detector in the pickup, then added by the RF amp to obtain RF, FE, TE, TE zero cross and other signals.

This pre-amp section is built in the servo LSI UPD63710GC (IC201). The following describes function of each section.

Since this system has a single power supply (+5V), the reference voltage for this LSI and pickup are set to REFO (2.5V). The REFO is obtained by passing the REFOUT from the LSI through the buffer amplifier. The REFO is output from Pin 89 of this LSI. All measurements are done using this REFO as reference.

Note : During the measurement, do not try to short the REFO and GND.

1) APC Circuit (Automatic Power Control)

When the laser diode is driven with constant current, the optical output has large negative temperature characteristics. Thus, the current must be controlled from the monitor diode so that the output may be constant. APC circuit is for it. The LD current is obtained by measuring the voltage between LD1 and V+5. The value of this current is about 35mA.

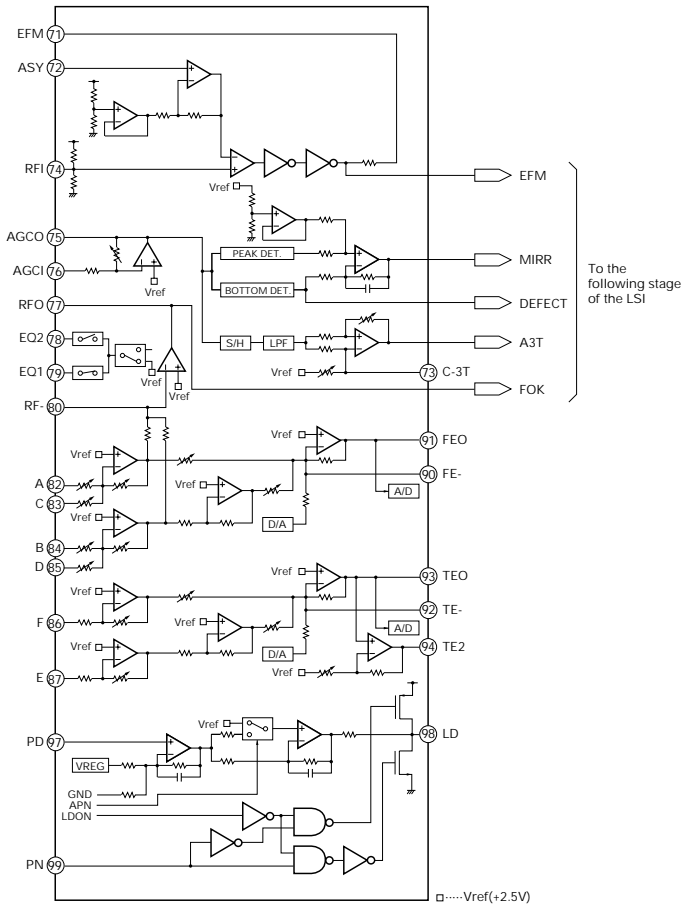

Fig.1 : BLOCK DIAGRAM OF BUILT-IN RF AMPLIFIER

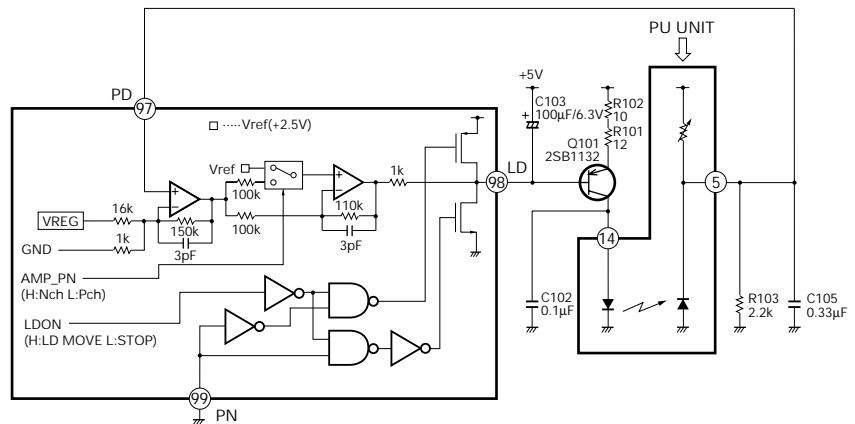

Fig.2 : APC CIRCUIT

2) RF Amplifier and RFAGC Amplifier

The photo-detector outputs (A + C) and (B + D) are added, amplified and equalized on this LSI and then output to the RFI terminal as the RF signal. (The eye pattern can be checked by this signal.)

The RFI voltage low frequency component is :

$$RFI = (A + B + C + D) \times 3.2$$

RFI is used on the FOK generator circuit and RF offset adjusting circuit.

R215 is an offset resistor for maintaining the bottom reference voltage of the RFI signal at 1.5 VDC. The D/A output used for the RF offset adjustment (to be described later) is entered via this resistor.

After the RFI signal from Pin 77 is externally AC coupled, entered to Pin 76 again, then amplified on the RFAGC amplifier to obtain the RFO signal.

The RFAGC adjustment function (to be described later) built-in the LSI is used for switching feedback gain of the RFAGC amplifier so that the RFO output may go to $1.5 \pm 0.3V_{pp}$.

The RFO signal is used for the EFM, DFCT, MIRR and RFAGC adjustment circuits.

3) FOK Circuit

This circuit generates the signal that is used for indicating the timing of closing the focus or state of the focus close currently being played. This signal is output from Pin 4 as the FOK signal. It goes high when the focus close and in-play.

The RFOK signal is generated by holding DC level of the RFI at its peak with the succeeding digital section, then comparing it at a specific threshold level. Thus, the RFOK signal goes high even if the pit is absent. It indicates that the focus close can take place on the disc mirror surface, too.

This signal is also supplied to the micro computer via the low pass filter as the FOK signal and used for the protection and the RF amplifier gain switching.

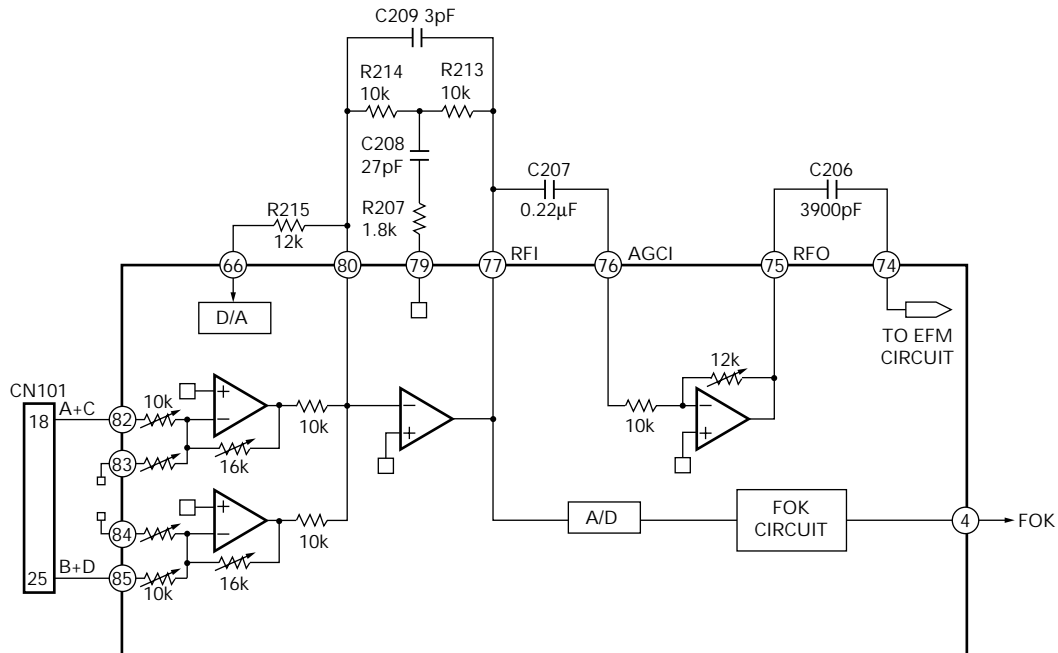

Fig.3 : RFAMP, RFAGC AND FOK CIRCUIT

4) Focus Error Amplifier

The photo-detector outputs (A + C) and (B + D) are passed through a differential amplifier and an error amplifier, and then (A + C - B - D) is output from Pin 91 as the FE signal.

The FE voltage low frequency component is :

$$FE = (A + C - B - D) \times \frac{16k}{10k} \times \frac{(80k//300k)}{20k}$$

$$= (A + C - B - D) \times 5$$

Using REFO as the reference, an S-curve of approximately 1.5 Vpp is obtained for the FE output. The final-stage amplifier cutoff frequency is 11.4 kHz.

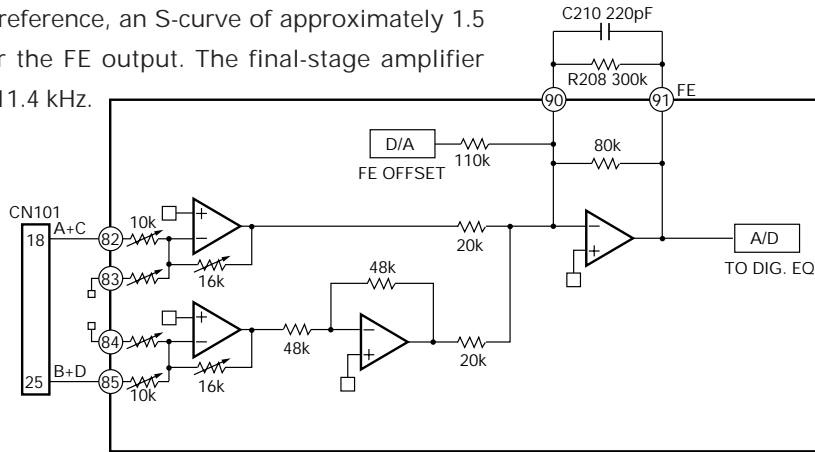

Fig.4 : FOCUS ERROR AMPLIFIER

5) Tracking Error Amplifier

The photo-detector outputs E and F are passed through a differential amplifier and an error amplifier, and then (E - F) is output from Pin 93 as the TE signal. The TE voltage low frequency component is :

$$TE = (E - F) \times \frac{224k}{(56k+27k)} \times \frac{80k}{38k}$$

$$= (E - F) \times 5.7 \text{ (Effective LSI output is 5.0).}$$

Using REFO as the reference, the TE waveform of approximately 1.3 Vpp is obtained for the TE output. The final-stage amplifier cutoff frequency is 20 kHz.

6) Tracking Zero Crossing Amplifier

TEC signal (the tracking zero crossing signal) is obtained by multiplying the TE signal four times. It is used for locating the zero crossing points of the tracking error. The zero cross point detection is done for the following two reasons :

- ① To count tracks for carriage moves and track jumps.
- ② To detect the direction in which the lens is moving when the tracking is closed (it is used on the tracking brake circuit to be described later).

The TEC signal frequency range is 300 Hz to 20 kHz.

$$TEC \text{ voltage} = TE \text{ level} \times 4$$

Theoretical TEC level is 5.2V. The signal exceeds D-range of the operational amplifier and thus is clipped. It, however, can be ignored since this signal is used by the servo LSI only at the zero crossing point.

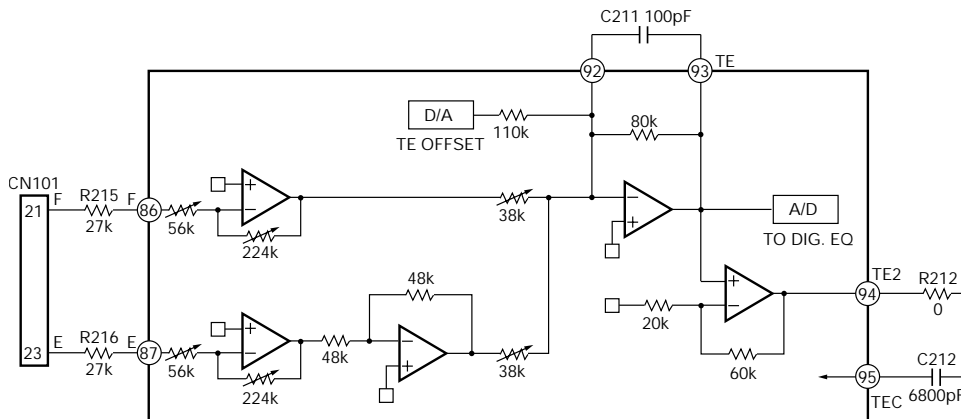

Fig.5 TRACKING ERROR AMPLIFIER AND TRACKING ZERO CROSSING AMPLIFIER

7) DFCT (Defect) Circuit

The DFCT signal is used for detecting defects on the mirrored disc surface. It allows monitoring from the HOLD pin (Pin 2). It goes high when defects are found on the mirrored surface.

The DFCT signal is generated by comparing the RF amplified signal (which is obtained by bottom holding the RFO signal) at a specific threshold level by the succeeding digital section.

Stains or scratches on the disc can constitute the defects on the mirrored disc surface. Thus, as long as the DFCT signal remains high in the LSI, the focus and tracking servo drives are held in the current state so that a better defect prevention may be ensured.

8) 3TOUT Circuit

The 3TOUT signal is generated by entering disturbance to the focus servo loop, comparing phase of fluctuations of the RF signal 3T component against that of the FE signal at that time, then converting the signal to DC level. This signal is used for adjusting bias of the FE signal (to be described later). This signal is not output from the LSI, thus its monitoring is not available.

9) MIRR (Mirror) Circuit

The MIRR signal shows the on track and off track data, and is output from Pin 3.

When the laser beam is

On track : MIRR = "L"

Off track : MIRR = "H"

This signal is used on the brake circuit (to be described later) and also as the trigger to turn on track counting when jumping take place.

The MIRR signal is supplied to the micro computer, too, for the protection purpose.

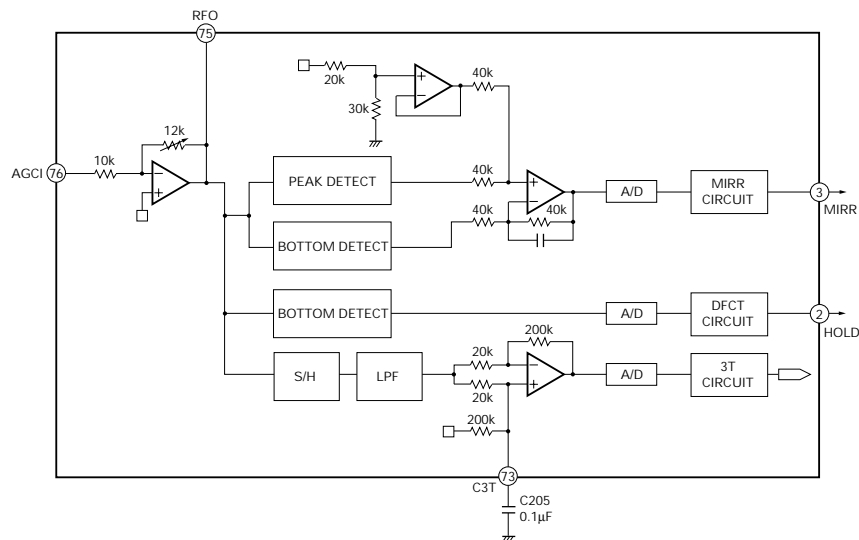

Fig.6 : DFCT, MIRR AND 3T DETECTION CIRCUIT

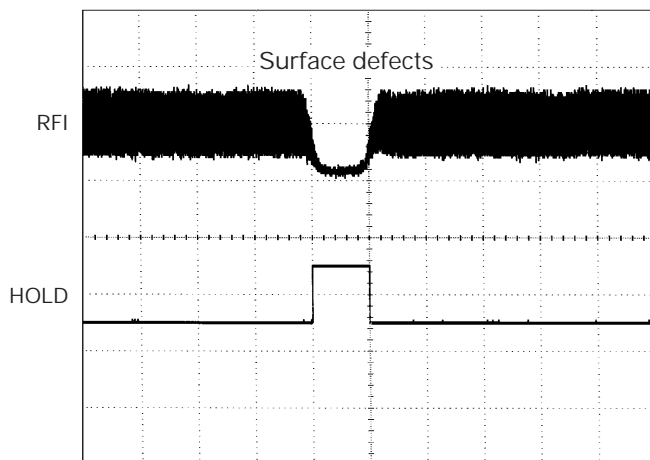

Fig.7 : HOLD OUTPUT WAVEFORM
(When surface defects are present)

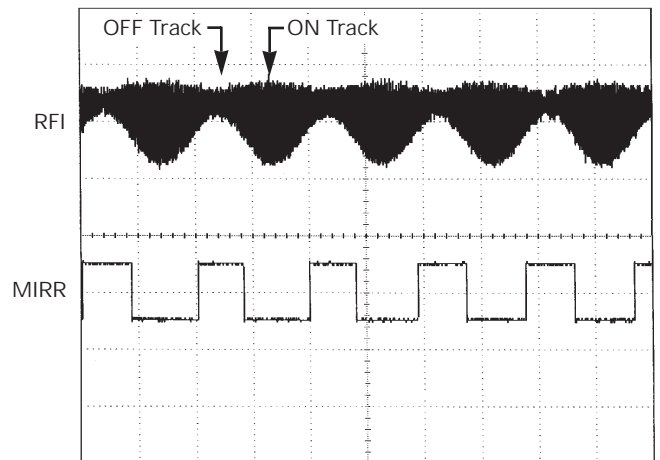

Fig.8 : MIRR OUTPUT WAVEFORM
(When an access is made)

10) EFM Circuit

This circuit is used for converting the RF signal to digital signal consisting of "0" and "1". The RFO signal from Pin 75 is externally AC coupled, entered to Pin 74, then applied to the EFM circuit.

Loss of the RF signal due to scratches or stains on the disc, or vertical asymmetry of the RF due to variations in the discs manufactured can't be eliminated by AC coupling alone. This circuit, therefore, controls the reference voltage ASY on the EFM comparator by use of the fact that "0" and "1" appear fifty fifty in the EFM signal. By this arrangement, the compare level is constantly maintained at almost center of the RFO signal level. The reference voltage ASY is generated when the EFM comparator output is passed through the low pass filter. The EFM signal is output from Pin 71. It is a 2.5 Vp-p amplitude signal centering on REFO.

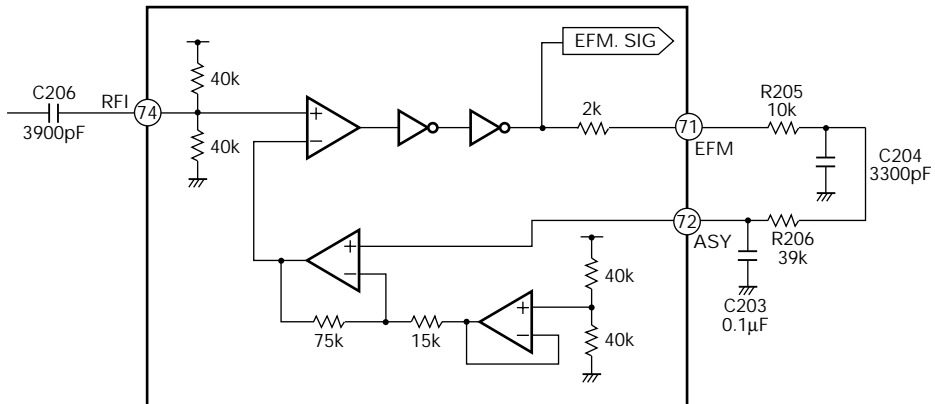

Fig.9 : EFM CIRCUIT

1.2 SERVO SECTION (UPD63710GC : IC201)

The servo section controls the operations such as error signal equalizing, in focus, track jump and carriage move. The DSP is the signal processing section used for data decoding, error correction and interpolation processing, among others.

This circuit implements analog to digital conversion of the FE and TE signals generated on the pre-amplifier, then outputs them through the servo block as the drive signal used on the focus, tracking and carriage system. The EFM signal is decoded on the signal processing section and finally output via the D/A converter as the audio signal. The decoding process also generates the spindle servo error signals which is fed to the spindle servo block to generate the spindle drive signal.

The focus, tracking, carriage and spindle drive signals are then amplified on the driver IC BA5986FM (IC301) and fed to respective actuators and motors.

1) Focus Servo System

The focus servo main equalizer is consisted of the digital equalizer. Fig.10 shows the focus servo block diagram.

When implementing the focus close on the focus servo system, the lens must be brought within the in-focus range. Therefore, the lens is moved up and down according to the triangular focus search voltage to find the focus point. During this time, the spindle motor is kicked and kept rotating as a set speed.

The servo LSI monitors the FE and RFOK signals and automatically carries out the focus close at an appropriate point.

The focus closing is carried out when the following three conditions are met :

- ① The lens approaches the disc from its current position.
- ② RFOK = "H"
- ③ The FZC signal is latched at high after it has once crossed the threshold set on the FZD register (Edge of the FZD).

As the result, the FE (= REFO) is forced to low.

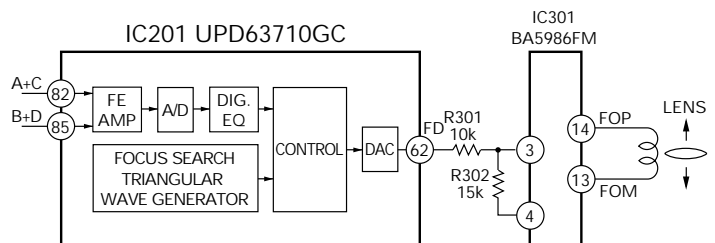

Fig.10 : FOCUS SERVO BLOCK DIAGRAM

When the above conditions are all met and the focus is closed, the XSI pin goes to low from the current high, then 40 ms later, the microcomputer begins to monitor the RFOK signal after it that has been passed through the low pass filter.

When the RFOK signal is recognized as low, the micro computer carries out various actions including protection.

Fig.11 a series of operations carried out relevant to the focus close (the figure shows the case where focus close is not available).

You can check the S-curve, search voltage and actual lens behavior by selecting the Display 01 for the focus mode select in the test mode, and then pressing the focus close button.

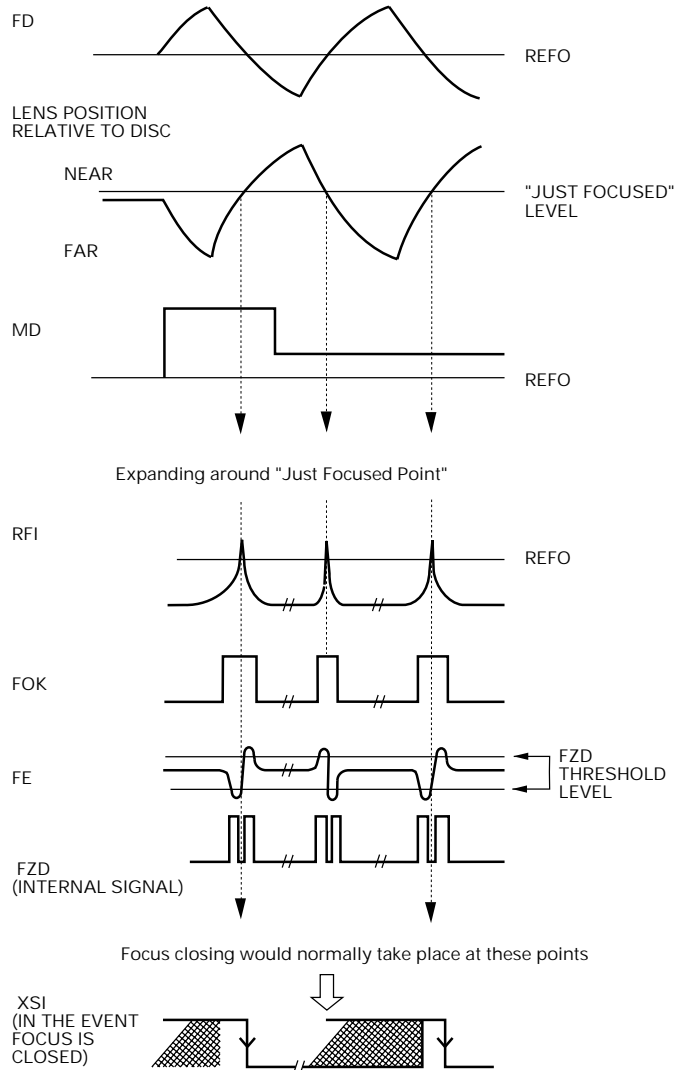

Fig.11 : FOCUS CLOSE SEQUENCE

2) Tracking Servo System

The digital equalizer is employed for the main equalizer on the tracking servo. Fig.12 shows the tracking servo block diagram.

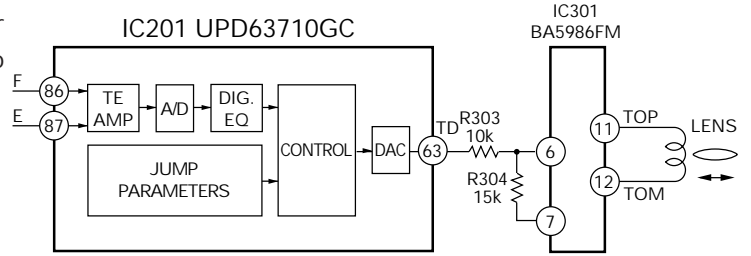

Fig.12 : TRACKING SERVO BLOCK DIAGRAM

a) Track jump

When the LSI receives the track jump command from the microcomputer, the operation is carried out automatically by the auto sequence function of the LSI. This system has five types of track jumps used for the search : 1, 4, 10, 32 and 32 × 3. In the test mode, in addition to three jumps (1, 32 and 32 × 3), move of the carriage can be check by mode selection. For track jumps, the microcomputer sets almost half of tracks (5 tracks for 10 tracks, for instance) and counts the set number of tracks using the TEC signals. When the microcomputer has counted the set number of tracks, it outputs the brake pulse for a fixed period of time (duration can be specified with the command) to stop the lens. In this way, the tracking is closed and normal play is continued.

To improve the servo loop retracting performance just after the track jump, the brake circuit is turned on for 50 ms after the brake pulse has been terminated to increase gain of the tracking servo.

Fast forward and reverse operations are realized by through consecutive signal track jumps. The speed is about 10 times as fast as that in the normal mode.

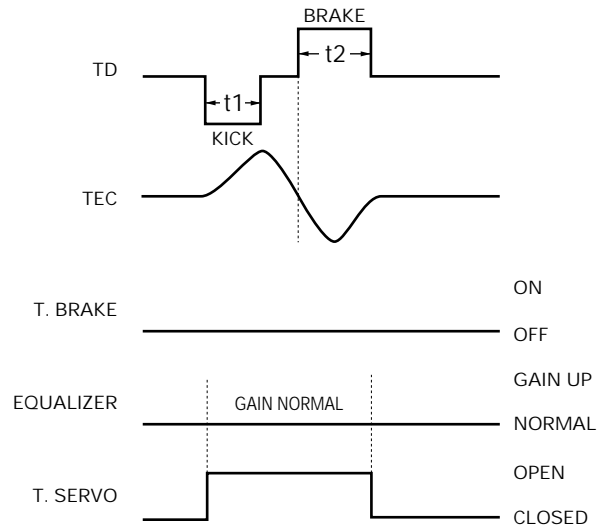

Fig.13 : SINGLE TRACK JUMP

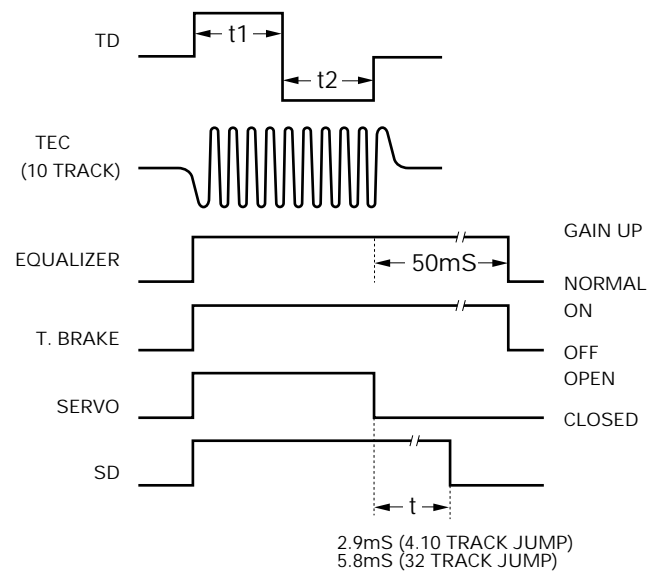
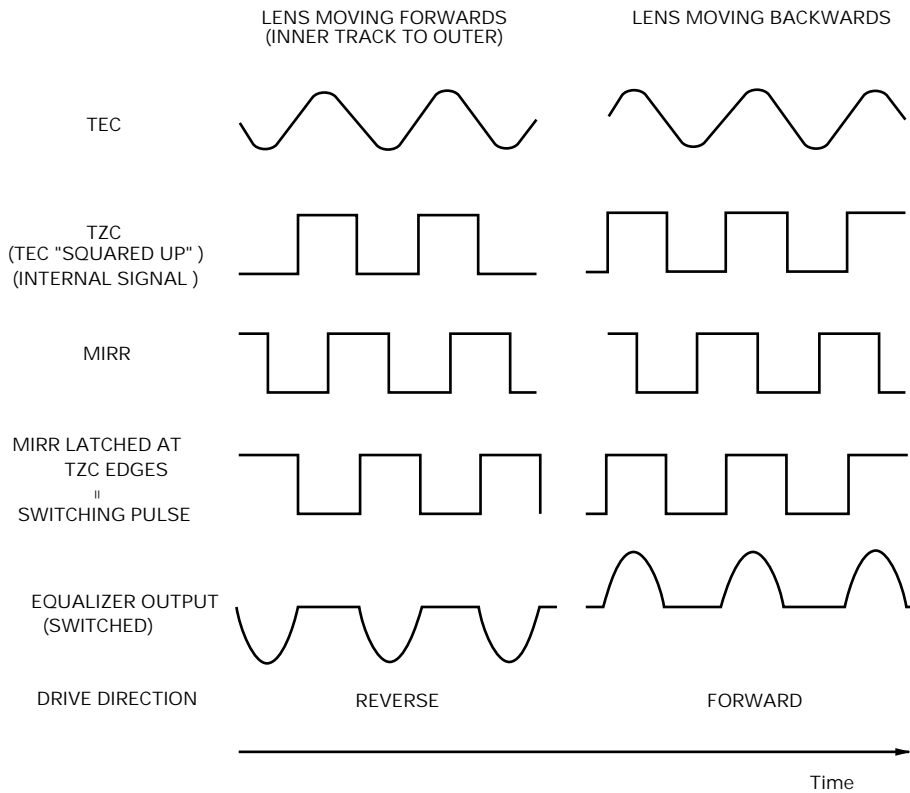

Fig.14 : MULTI-TRACK JUMP

b) Brake Circuit

The servo retracting performance can be deteriorate during the setup or track jump operation. In this connection, the brake circuit is used to ensure steady retract of the tracking servo. The brake circuit detects in which direction the lens is moving, then slows down its move by outputting the drive signal that moves the lens into the opposite direction alone. Track slippage direction is determined by referencing the TEC and MIRR signals and their phase.



Note : Equalizer output assumed to have same phase as TEC.

Fig.15 : TRACKING BRAKE CIRCUIT

3) Carriage Servo System

The carriage servo supplies the tracking equalizer's low-frequency component (lens position data) output to the carriage equalizer, then, after providing a fixed amount of gain to it, outputs the drive signal from the LSI. This signal is then applied to the carriage motor via the driver IC.

When the lens offset reaches a certain level during play, the entire pickup must be moved into the forward direction. Therefore, the equalizer gain is set to the level that allows to generate a voltage higher than the carriage motor starting voltage. In actual operations, a certain threshold level is set for the equalizer output by the servo LSI so that the drive voltage may be output from the servo LSI only when the equalizer output exceeds the threshold level. This arrangement helps reducing power consumption. Also, due to disc eccentricity or other factors, the equalizer output may cross the threshold level a number of times. In this case, the drive voltage output from the LSI will have pulse-like waveform.

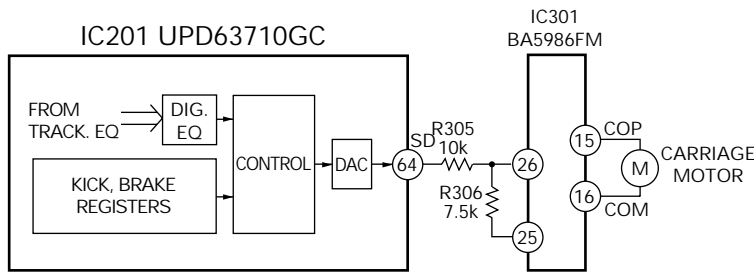

Fig.16 : CARRIAGE SERVO BLOCK DIAGRAM

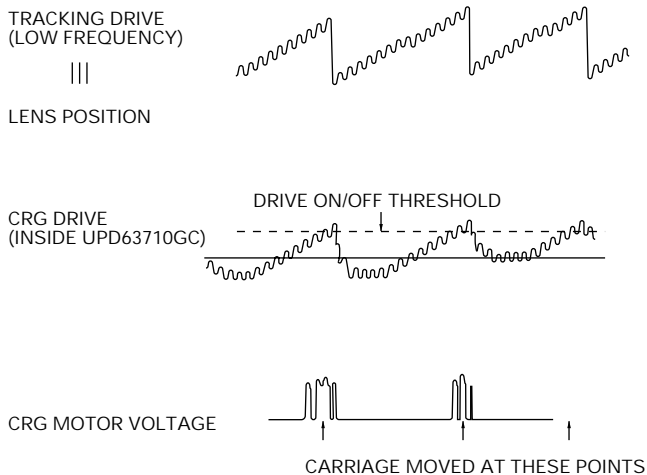

Fig.17 : CARRIAGE SIGNAL WAVEFORM

4) Spindle Servo System

The spindle servo has the following modes.

① Kick :

This mode is used for accelerating the disc rotation during setup.

② Offset :

(a) After the kick is over in the setup, this mode is turned on until changing to rough servo mode.

(b) When focus is lost during play, this mode is turned on until the focus is restored.

Both of the above are used for maintaining the disc rotation rate near to the specified rate.

③ Applicable servo :

The CLV servo mode is turned on for the normal operations.

In the EFM demodulation block, the frame sync signal and internal counter output signal are sampled for every $WFCK/16$ and a signal is produced for indicating whether or not they are matching.

They are determined to be asynchronous only when this signal fails to match 8 times in succession. In all other cases, above two signals are assumed to be synchronous. In the applicable servo mode, the retracting servo is automatically selected if the two signals are synchronous. If not, the regular servo is automatically selected.

④ Brake :

This mode is turned on when stopping the spindle motor.

The microcomputer outputs the brake voltage through the servo LSI. The LSI monitors the EFM waveform and, if its longest pattern exceeds a certain interval (if the rotation is sufficiently slow), the flag is set the LSI and the microcomputer turns off the brake voltage. When the flag is not up within a specified period time, the microcomputer switches the mode from the brake to the stop mode, and maintains this mode for a fixed period of time. If this stop mode is continued for a fixed period of time, the disc will be ejected.

⑤ Stop :

This mode is used for powering on the system and the eject operation. When this mode is turned on, voltage across the spindle motor is 0V.

⑥ Rough servo :

This mode is used for when the carriage feed (carriage mode for the long search, etc.) is turned on. The linear speed is calculated from the EFM waveform and high or low level is entered to the spindle equalizer. In the test mode, this mode is also used for the grating check.

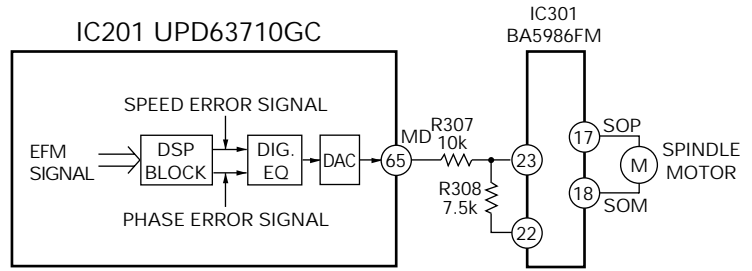

Fig.18 : SPINDLE SERVO MOTOR BLOCK DIAGRAM

1.3 AUTOMATIC ADJUSTMENT FUNCTIONS

Every circuit adjustment on the CD-LSI of this system is automated.

Every circuit adjustment is automatically implemented when the disc is inserted or the CD mode is selected from the source key. The following describes how the adjustments are executed.

1) FZD Cancel Setting

This setting is used for executing the focus close operation without fail.

When power is turned on, the FE offset level is read and a voltage opposite to this offset value is written to the CRAM on the IC to cancel the offset. In this manner, the FZD threshold level can be set to a constant value (+240mV), thereby ensuring to meet one of the requirements for the IC to execute the focus close that "the FZD signal is latched at high".

2) Automatic Adjustment of TE, FE and RF Offset

Using REFO as the reference, this function adjusts the pre-amp TE, FE and RF offsets to the respective target value when power is turned on (targets values of the TE, FE and RF are 0, 0 and -1V, respectively).

The following is the adjustment procedure :

- (1) Respective offset (LD off) is read by the microcomputer via the servo LSI.
- (2) The microcomputer calculates the voltages to be corrected from the read values, then sets them to the specified field.

3) Automatic Adjustment of Tracking Balance (T. BAL)

This adjustment is used for eliminating differences between the pickup E and F channels outputs by adjusting gain of the amplifier on the LSI. In the actual operation, the TE waveform is adjusted so that it may be vertically symmetric with REFO.

The following is the adjustment procedure :

- (1) Make sure the focus close is complete.
- (2) Kick the lens in the radial direction to generate the TE waveform.
- (3) At this time, the microcomputer reads the TE signal offset value (via the servo LSI) being calculated by the LSI.

- (4) The microcomputer determines if the read offset value is positive, negative or zero.

If the offset value = 0, the adjustment is terminated.

If the offset value = A positive or negative value, gain of the E and F channels amplifiers are modified according the predetermined rule.

Then above steps (2) through (4) are repeated until the "Offset value = 0" or "Specified limit count" is reached.

4) Automatic Adjustment of FE Bias

This adjustment is intended at maximizing the RFI level by optimizing the focus point in-play. This adjustment utilizes the phase difference between the RF waveform 3T level and the focus error signal when disturbance is applied.

Since disturbance is applied to the focus loop, this adjustment is designed to take place in the same timing as the auto gain control (to be described later).

The following is the adjustment procedure :

- (1) Disturbance is injected to the focus loop by the command from the microcomputer (within the servo LSI).
- (2) The LSI detects fluctuation of the RF signal 3T component level.
- (3) The LSI determines relationship between fluctuation of the 3T component and the injected disturbance to detect magnitude and direction of the off-focus introduced.
- (4) The microcomputer reads the detected results from the LSI.
- (5) The microcomputer calculates necessary correction, then hands the calculated value to the bias adjustment term set on the LSI.

This adjustment is repeated several times, as it is so with the auto gain control, to ensure higher accuracy.

5) Focus and Tracking Automatic Gain Control

This function is used for implementing automatic control of the focus and tracking loop gain.

The following is the adjustment procedure :

- (1) Inject disturbance to the servo loop.
- (2) Extract the error signal (FE and TE) generated at when the disturbance is applied to obtain the signals G1 and G2 via the B.P.F.
- (3) The microcomputer reads the G1 and G2 signals via the LSI.
- (4) Based on the necessary correction calculated by the microcomputer, the LSI performs the loop gain adjustment.

Above adjustments are repeated several times to ensure higher adjustment accuracy.

6) Automatic RF Level Adjustment (RFAGC)

This adjustment is used for implementing intended signal transmission successfully by adjusting unevenness of the RF signal (RFO) levels, that results from disc and machine relevant factors, to a target value. The adjustment is actually done by varying gain of the amplifier provided between the RFI and RFO.

The following is the adjustment procedure :

- (1) Using the command, the microcomputer reads the output from the RF level detection circuit on the servo LSI.
- (2) Based on the read value, the microcomputer calculates an amplifier gain that will produce the target RFO level.
- (3) The microcomputer sends the corresponding command to the servo LSI so that the above gain value may be set.

This adjustment takes place at the following timing :

- When the focus close alone is completed during the setup process.
- Just before the setup is completed (just before the play takes place).
- After the off-focus has been corrected during the play.

7) Adjustment of Pre-Amp Stage Gain

It is used for adjusting the entire RFAMP (FE, TE and RF amplifiers) to +6dB or +12dB depending on given gain level when reflected light from the disc is significantly below the required level due to stained lens. This phenomena can be noticed when playing back the CD-RW.

The following is the adjustment procedure :

When reflected light from disc is judged to be significantly below the required level during the setup, set the entire RFAMP to +6dB or +12dB. In this case, if the gain is modified, the setup have to be repeated from the first step.

Through the adjustment, if you judged the play becomes available by setting the entire RFAMP to +6dB, +6dB should be selected for the setup next time on.

See the figure below :

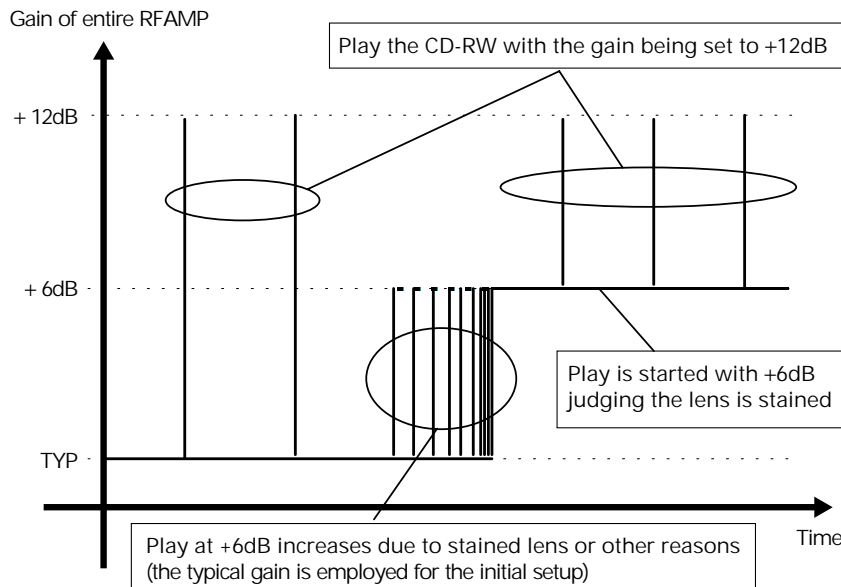

Fig.19 : CONCEPTUAL DIAGRAM OF PRE-AMP GAIN ADJUSTMENT

8) Initial Adjusting Values

All the automatic adjustments are implemented using the previous adjustment values as the initial values unless the microcomputer power (the backup power) is not turned off (though there are some exceptions).

When the backup is turned off, automatic adjustment is executed based on the initial values rather than the previous adjustment values.

9) Displaying Coefficients After Adjustment

You can display and check results of some automatic adjustments (FE and RF offset, FZD cancel and F / T / RFAGC) from the test mode. The following coefficients are displayed in each automatic adjustment :

(1) FE and RF offset and FZD cancel

Reference value = 32 (The coefficient of 32 indicates that no adjustment was required).

The results are displayed in multiples of approximately 40 mV.

An example : When FZD cancel coefficient = 35

$$35 - 32 = 3$$

$$3 \times 40 \text{ mV} = 120 \text{ mV}$$

Since the corrected value is approximately +120 mV, the FE offset before adjustment was -120 mV.

(2) F and T gain adjustment

Reference value = Focus/Tracking = 20

A coefficient displayed indicates an amount of adjustment conducted on the reference value.

An example : When AGC coefficient = 40

$40/20 =$ Overall gain has been doubled (+6dB). (The original loop gain of 1/2 has been doubled to have the targeted overall gain.)

(3) RF level adjustment (RFAGC)

Reference value = 8

Coefficient = 9 to 15 The direction in which the RF level is increased (the gain is increased).

Coefficient = 7 to 0 The direction in which the RF level is decreased (the gain is decreased).

Incrementing or decreasing the coefficient by "1" varies the gain by 0.7 to 1dB.

Maximum gain = Typically +6.5dB. Coefficient at this time is 15.

Minimum gain = Typically -6.0dB. Coefficient at this time is 0.

1.4 POWER SUPPLY UNIT CONFIGURATION

The power supply unit of this system consists of 4 power sources, VD(8.6V), 5VA(5V), 4R3VLR(4.3V) and EVREF(5V).

- VD :Main power source. Generated in the expansion board.
- 5VA :Power source for IC201 and the Pick-up Unit. Generated by the regulator IC (IC101) from VD.
- 4R3VLR :Audio midpoint voltage. Generated by the regulator IC (IC603) from VD.
- EVREF :Power source for Linear Position Sensor. A/D reference voltage of the microcomputer. Usually taken from the microcomputer's VDD line via an enabling switch.

1.5 MECHANISM OPERATION

1) Elevation Operation

The microcomputer determines the present elevation position from the voltage value (EPVO) obtained from the potential divider VR801.

The voltage of the position of the requested disk is calculated from figure 20 and the ELV Motor is controlled so that the EPVO voltage is matched to the value obtained from the calculation.

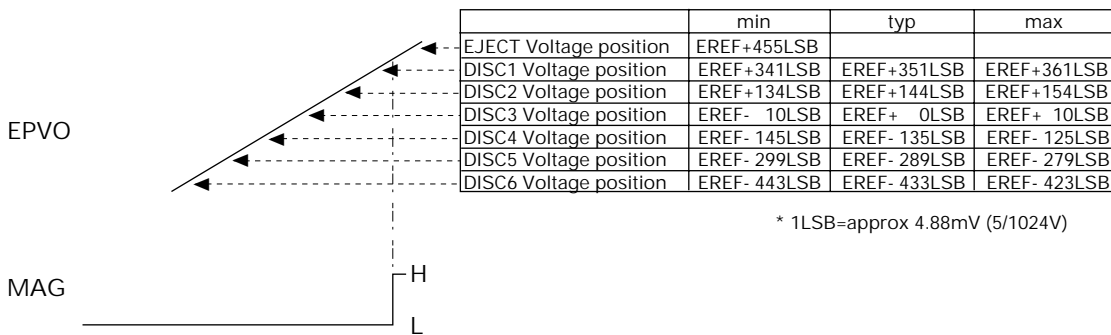
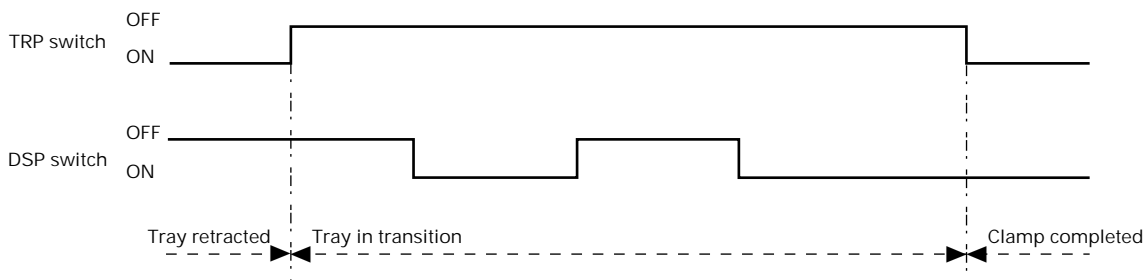

Fig. 20

2) Tray Extension and Retraction

The microcomputer detects the DSP signal waveform (voltage) and TRP signal waveform (voltage) obtained at the DSP switch (S852) and the TRP switch (S851) by tray retraction, tray extension and clamp completion and controls the Tray Motor.



3) 0.6mm UP/DOWN Operation

In order to secure clearance with the neighboring disk the Stage Mechanism is driven down by the ELV Motor (M852) when clamping is complete. The microcomputer detects the completion of clamping, and when the Tray Motor is brought to a full stop, the ELV Motor (M852) is forcibly driven for a 240 ms interval in the downward direction.

When the tray is being retracted, the ELV Motor (M852) is controlled to match the value of EPVO calculated during the elevation operation. The tray retraction operation is started when the Tray has been moved to the prescribed position.

Each motor is driven by the driver IC302 (LB1836M). LB1836M is an IC which usually operated through the combination of H and L of the 4 lines I1, I2, I3 and I4. With this system, I1=I3 and control is realized through a combination of H and L of the 3 lines I1, I2 and I4.

ELV Motor	Tray Motor	I1,I3	I2	I4
Forward	Brake	H	H	L
Reverse	Stand-by	L	L	H
Brake	Forward	H	L	H
Stand-by	Reverse	L	H	L
Brake	Brake	H	H	H
Stand-by	Stand-by	L	L	L

* ELV Motor Forward : ELV-up (Disc No. Down)
 Tray Motor Forward : Tray Ejection

4) Disc Detection

The DSP signal waveform (voltage) at the DSP switch (S852) is used for determining the existence and non-existence of a disk and the disk type (8cm or 12cm). The disk detection operations are carried out while the Tray is being pulled out of the magazine. Disk detection is determined when the light passes through (DISC waveform L:less than 2.5v) or is interrupted (DISC waveform H:2.5V or above) with an array of LEDs and photo transistors above and below the Tray.

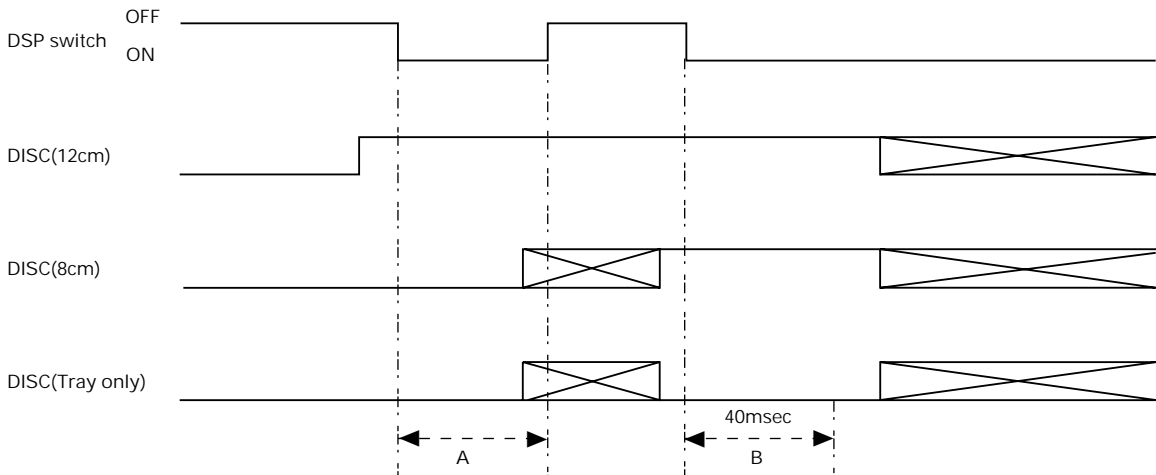

The DISC waveform is continuously monitored within the intervals A and B above and if a L is detected even once, that interval is determined as L. If a L is not detected at all then that interval is determined as H in the following.

	A	B
12cm	H	H
8cm	L	H
No Disk	—	L

Cautions on Service

- 1) Do not hold the upper frame of the magazine insertion port in the CD mechanism module, marked by an arrow in Fig. 21, when servicing. It's because this section is easily deformed.

CD mechanism module

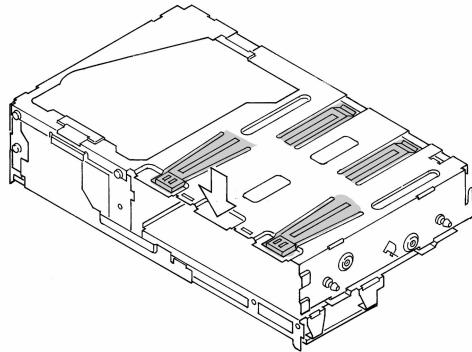

■ This section is easily deformed.

Fig. 21

- 2) The stage mechanism section projects below the chassis when positioned at the fifth stage or lower. So, do not leave the stage mechanism section at these positions to avoid damage or malfunction.
- 3) Before removing the flexible card and pickup flexible PCB from the connectors on the relay PCB, be sure to insert a short pin into the pickup unit first.
- 4) When replacing the tray motor assy, mount the 2-stage gear(Not resable) on the shaft of a new tray motor assy. (As the gear uses snap-on fittings, push it in until it is snapped completely.)
- 5) When replacing the magazine holder assy, mount the worm wheel(Not resable) on the shaft of a new elevation worm wheel.
(As the gear uses snap-on fittings, push it in until it is snapped completely.)

2. DISASSEMBLY

● Removing the Pickup Unit

1. Insert a short pin into the pickup flexible PCB.
2. Remove the pickup flexible PCB from the connector.
3. Remove the flexible card from the connector.
4. Remove the lead wires of the spindle motor assy and carriage motor assy by removing solder.
5. Loosen the two screws. Lift up the relay PCB as shown in Fig. 22.

Be careful not to excessively pull the tray motor flexible PCB and the relay flexible PCB.

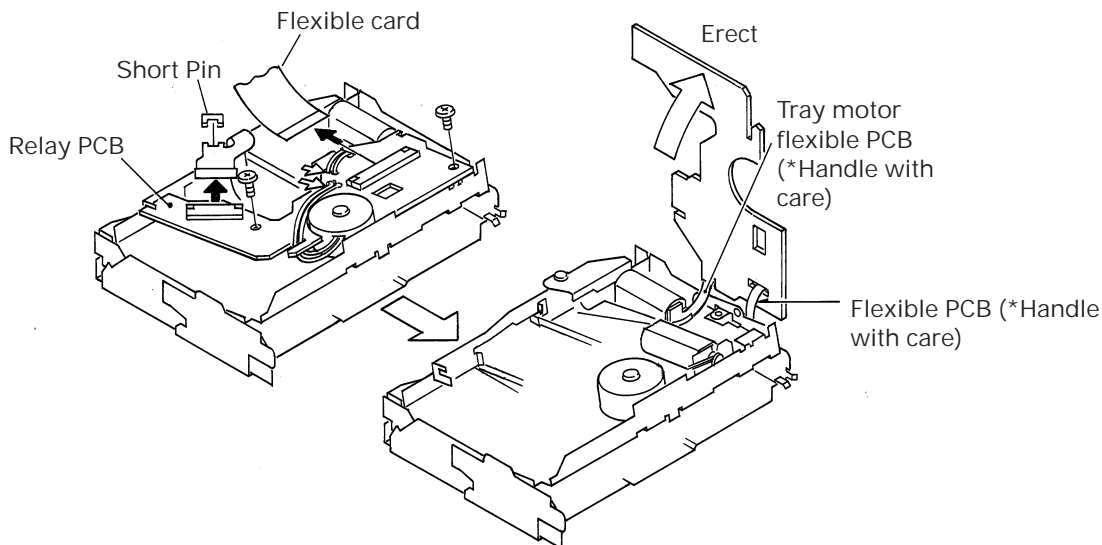

Fig. 22

6. Remove three screws A and then remove the carriage motor assy, remove the lighting conductor , screw holder, feed screw and belt (see Fig. 23).
7. Remove screw B on the main side and the pickup unit together with the guide shaft (see Fig. 23).

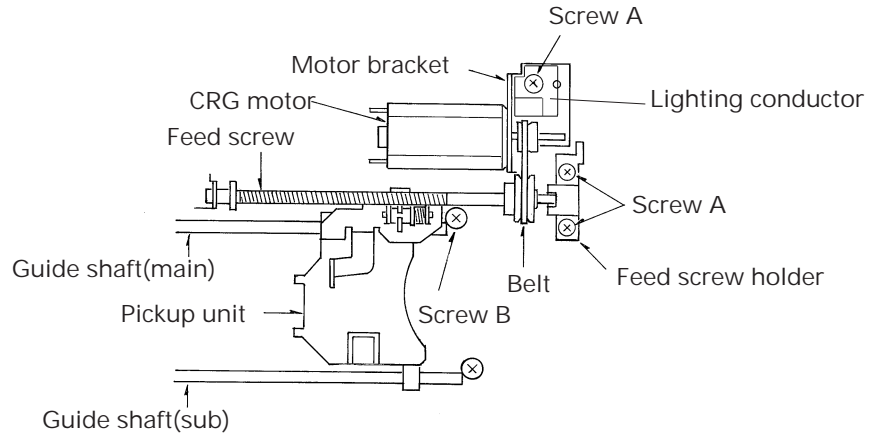

Fig. 23

● Removing the CD Core Unit

1. Insert a short pin into the pickup flexible PCB.
2. Remove the flexible card from the CD core unit connector.
3. Remove the lead wires of the elevation motor assy that were soldered to the CD core unit.
4. Remove screw C and three screws D and then the CD core unit (see Fig. 24).

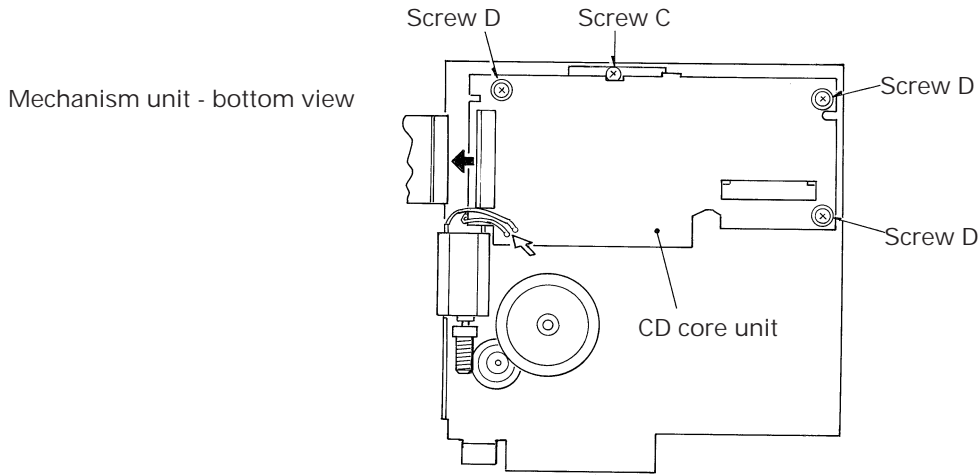

Fig. 24

● Cautions on Mounting the CD Core Unit

When mounting the CD core unit on the CD mechanism module, accurately insert the linear position sensor (Slide control: VR801) mounted on the CD core unit into the U-shaped groove of the elevation front lever (see Fig. 35).

If the linear position sensor is not inserted into the U-shaped groove, elevation operation will malfunction.

● Removing the Carriage Motor Assy

After removing the pickup unit (see "Removing the Pickup Unit" in pages 17 and 18), remove the feed screw, remove the lighting conductor, belt, and feed screw holder.

● Removing the Spindle Motor Assy

1. Rotate the tray motor until the clamp joint arm moves.
2. Slide and remove the clamp spring as shown in Fig. 25.
3. Remove the clammer.
4. As shown below, match the positions of the holes of the support wheel and screws F. Then remove the two screws F and spindle motor assy.

* When removing the clammer, be careful not to lose the ball mounted between the clammer and clamp spring.

Release the clamp spring from the hook(s), and then slide it in the direction indicated with an arrow.

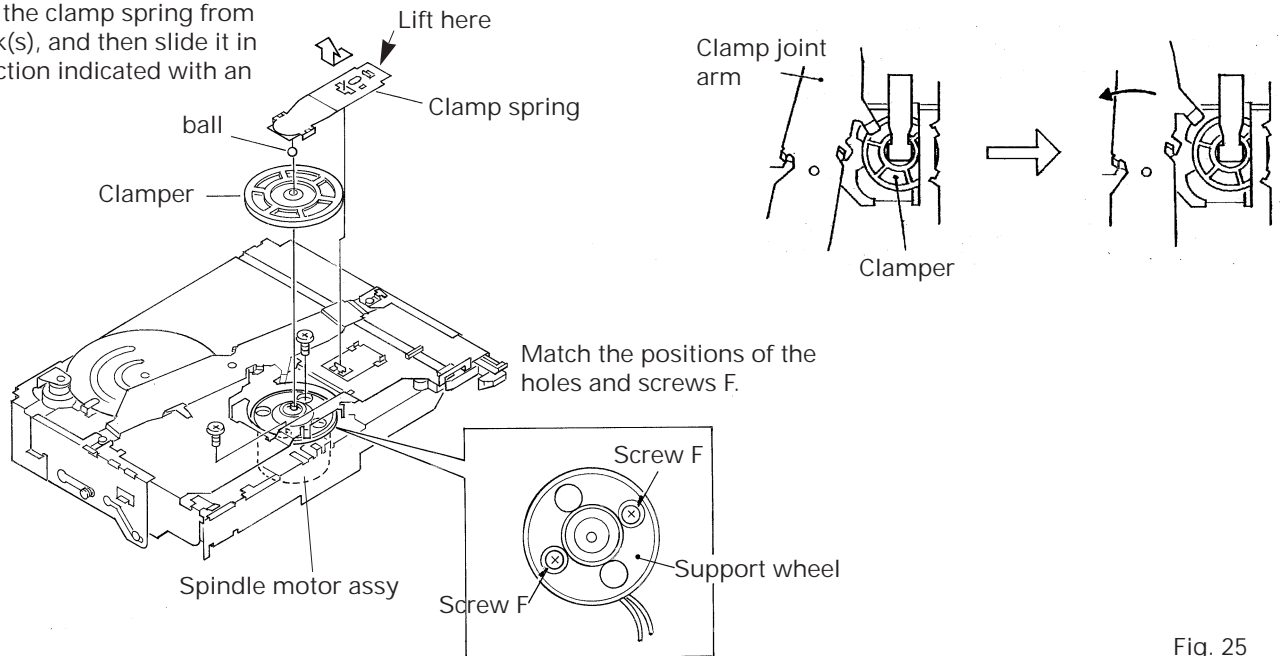

Fig. 25

● Cautions on Mounting the Spindle Motor Assy

1. Mount the spindle motor assy so that the lead wires face the rear of the mechanism unit (see Fig. 26).

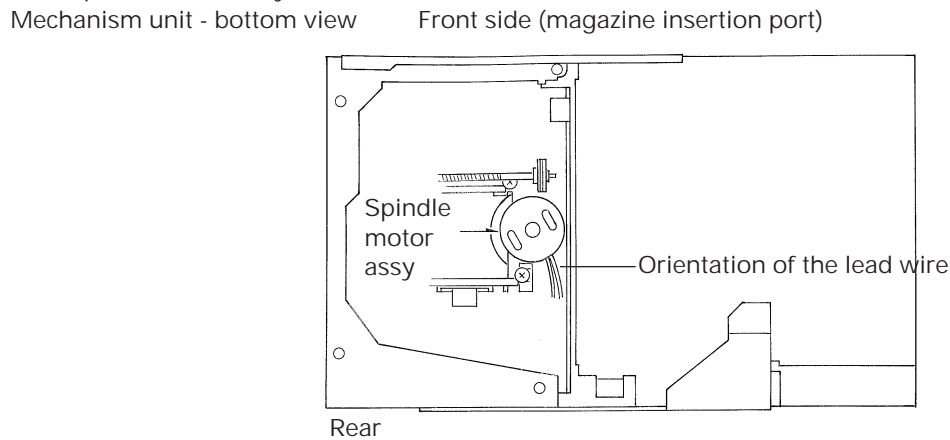

Fig. 26

2. Check that the torsion spring presses the side pressure plate (see Fig. 27).

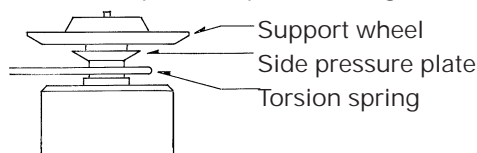

Fig. 27

3. When mounting the clammer, confirm that the ball has been installed.

● Removing the Tray Motor Assy (see Fig. 28)

1. Remove screw G.
2. Remove the elevation joint arm spring.
3. Remove the polyslider washer and the 2-stage gear.
4. Move the front lever to move the stage mechanism unit to the "2" position on the front lever.
5. Remove screw H.
6. Move the front lever again to move the stage mechanism unit to the uppermost stage.
7. Remove the tray motor assy.

● Cautions on Mounting the Tray Motor Assembly (see Fig. 28)

When mounting the 2-stage gear, verify that the positions of the holes of the 2-stage gear and the stage chassis match each other. For easy confirmation, check that the shapes of the 2-stage gear and the stage chassis form a concentric circle, as shown in the figure.

● Removing the Elevation Motor bracket Assy (see Fig. 28)

1. Remove the elevation joint arm spring.
2. Remove the polyslider washer and the 2-stage gear.
3. Remove two screws I and the elevation motor bracket assy

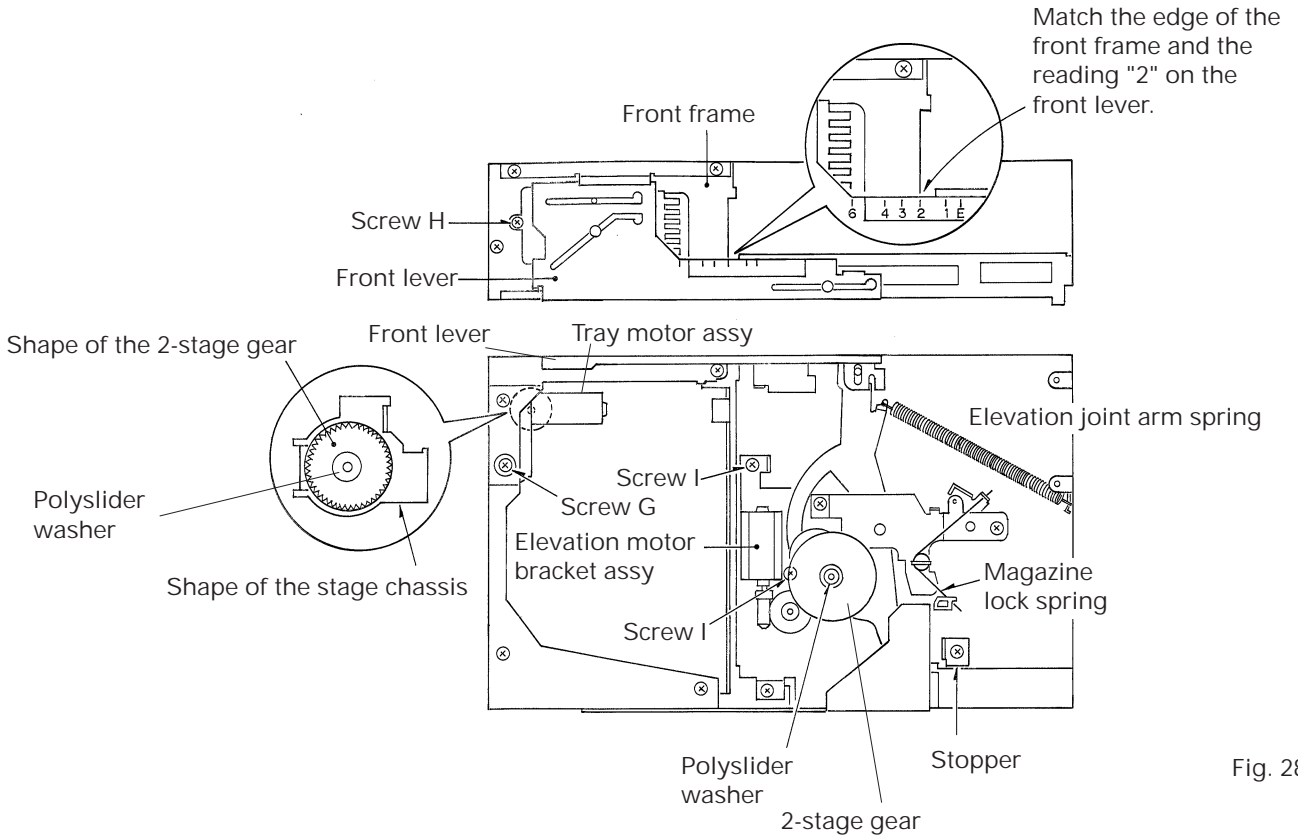

Fig. 28

● Removing the Stage Mechanical Unit Section (see Fig. 29)

1. Remove the elevation joint arm spring.(See Fig. 28)
2. Remove the magazine lock spring.(See Fig. 28)
3. Remove the 2-stage gear.(See Fig. 28)
4. Remove the screw J and then the stopper.
5. Fully slide the front lever in the direction that the stage mechanism assy moves upwards. Then, the front lever and the rear lever can be removed at the same time.
6. Remove three screws K and two screws L, and then the magazine holder Assy.
7. Remove four screws M and then the lower frame.
8. Remove three screws N and then the front frame.
9. Move the stage mechanism assy to the lowest position. Slide the bent section of the stage mechanism assy along the L-shaped groove in the front frame to remove the stage mechanism assy.

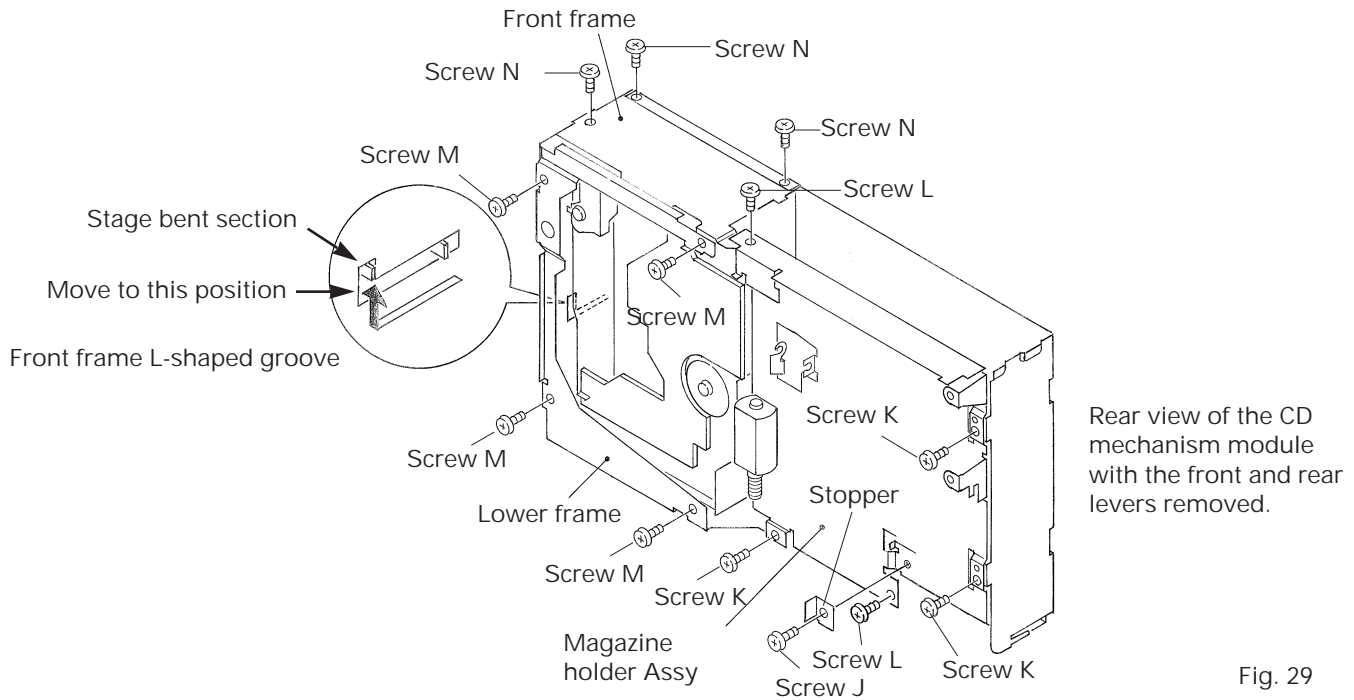

Fig. 29

3. MECHANISM DESCRIPTIONS

● Inserting the Magazine

1. When the magazine is inserted against the force of the EJECT lever spring, the lock arm comes in along the groove in the rear side of the magazine to lock (see Fig. 30).

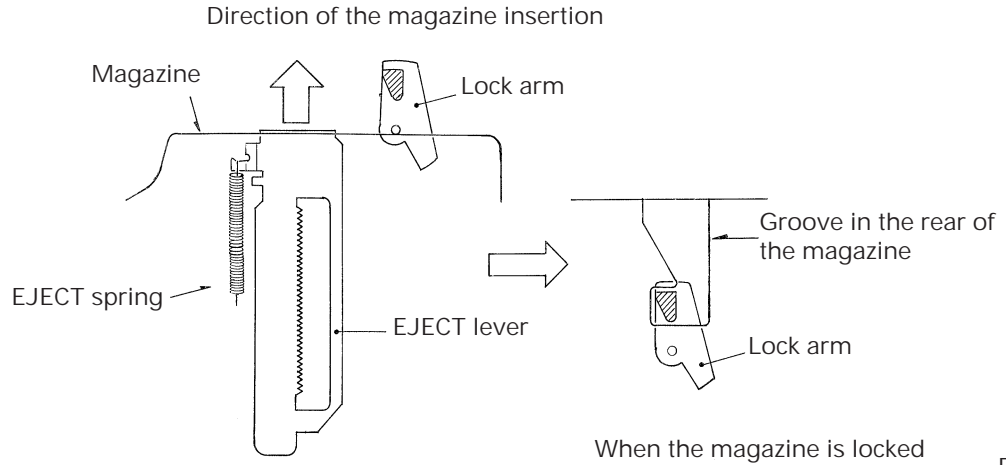

Fig. 30

2. The magazine lock is detected when the detection arm moves along the EJECT lever cam section and presses the magazine detection switch mounted on the CD core unit. When the magazine is not inserted, the detection arm is held at the SW OFF position by the EJECT lever cam (see Fig. 31).

When the magazine starts insertion, the lock arm starts moving along the groove in the rear of the magazine. Then the lock arm stops at the detection arm "stop" position. Although the detection arm tries to move in the SW ON direction, the lock arm stops it. (See Fig. 32.)

When the magazine is completely inserted, the magazine to lock. At the same time, the detection arm is released to press the magazine detection switch with spring force. (See Fig. 33)

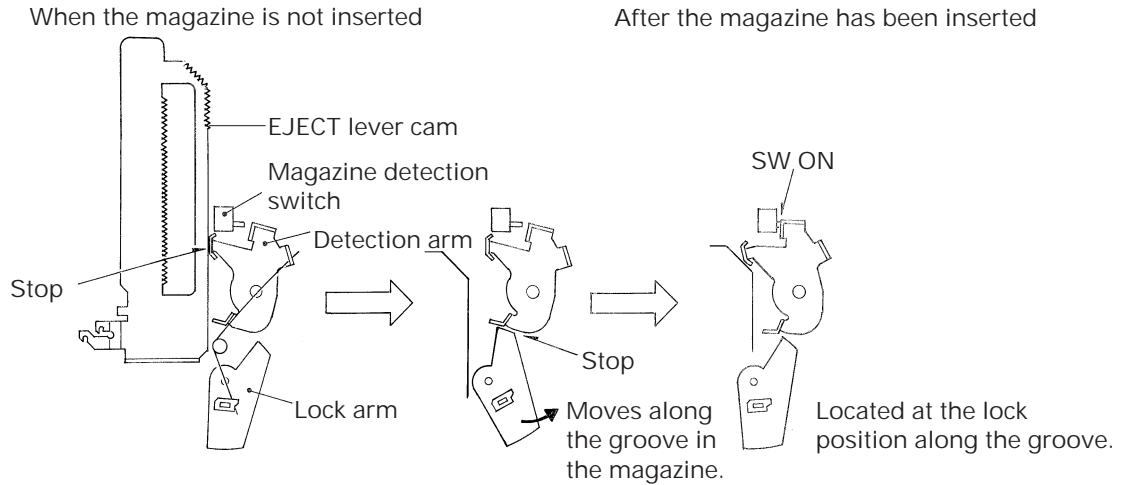

Fig. 31

Fig. 32

Fig. 33

● Elevation Operation (see Fig. 34)

When the elevation motor is driven, the elevation joint arm rotates. The front and rear levers, engaged with the ends of the elevation joint arm respectively, slide to move the stage mechanism unit up and down.

● Detecting Elevation (see Fig. 35).

When the elevation joint arm rotates, the front lever slides.

Because the knob of the linear position sensor (slide control: VR801) is inserted in the U-shaped groove of this front lever, the elevation joint arm moves in synchronization with the lever and detects the voltage at that time.

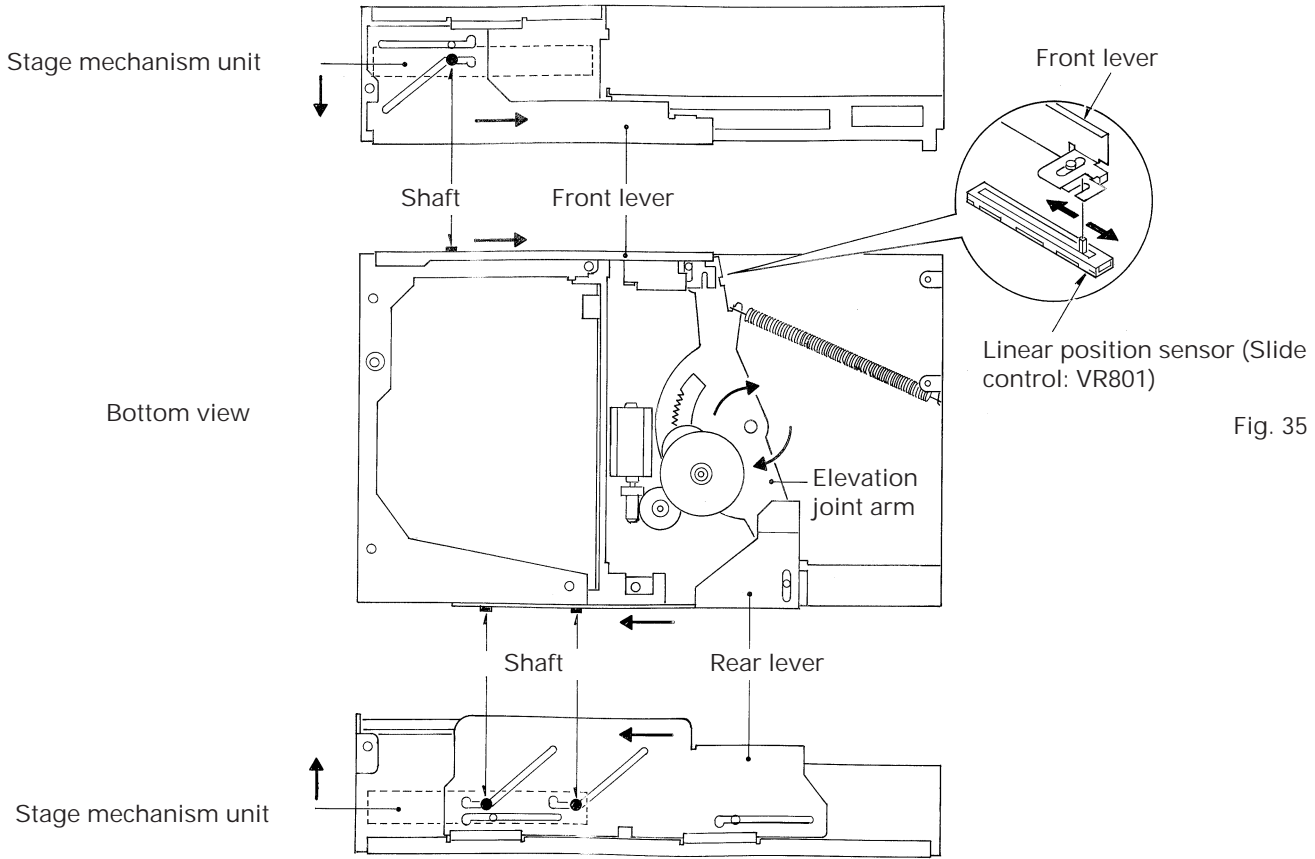

Fig. 35

Fig. 34

● Tray Extraction to Clamp Operation (Loading Motor Drive Section) (See Fig. 36.)

When the loading motor drives the cam gear, the cam gear moves the tray extraction arm along the cam groove to extract the tray. At that time, the carriage assy (including the spindle motor assy and tray positioning pin) waits until the tray passes it. When tray extraction has been completed, the cam gear swings the clamp joint arm and slides the clamp lever engaged with the clamp joint arm. The shaft of the carriage assy is lifted along the step-shaped groove as the clamp lever slides. The carriage assy swings toward the stage chasis. Subsequently, the spindle motor assy comes to a CD disc to load and lift it up from the tray.

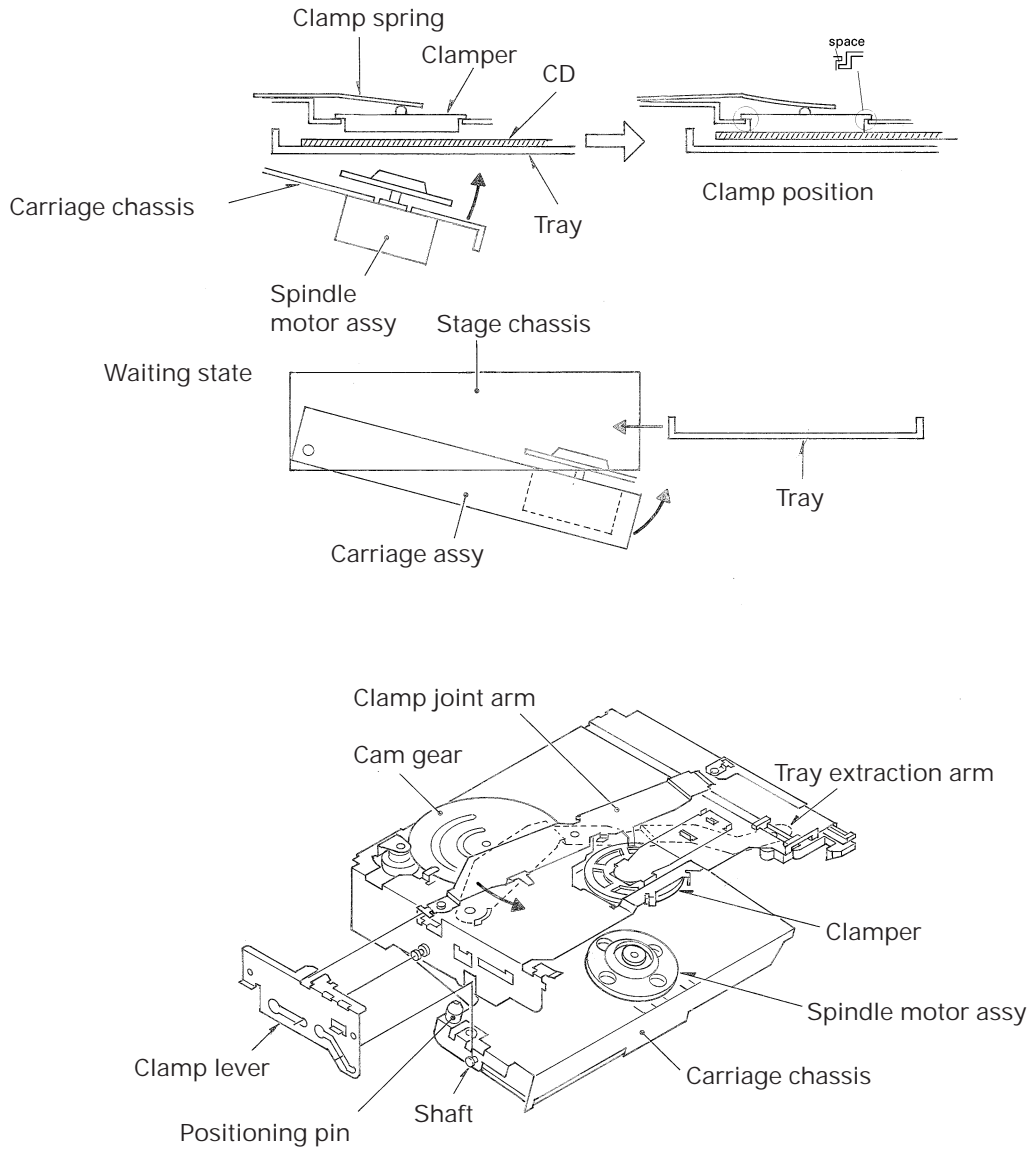

Fig. 36

● Elevation Mechanism - Play Elimination

Immediately before the clamp operation is completed, the bent sections of the clamp lever comes into the frame stopper section and press it downward to control the vertical position. This operation can press the stage downward by means of the elevation mechanism. At this time, the elevation motor stops, not by the detection of the pressed position, but in a certain period of time after the elevation mechanism moves up to the limit of the movement. (See Fig. 37)

The figure 37 shows the pressing mechanism. When the clamp lever bent sections press the framestopper section, the carriage chassis shaft inserted into the clamp lever groove is lifted up until it is pressed against the end of the vertical groove in the stage chassis. At this time, the stage chassis shaft, which is also inserted into the other groove in the clamp lever, is located at the wider portion of the groove so that the carriage chassis shaft can move to the end of the vertical groove in the stage chassis. This pressing operation eliminates the play at each of the stage chassis, carriage chassis, clamp lever, and the frame to improve the resistance against vibration. (See Fig. 39.)

* The elevation joint arm spring has been installed to keep this pressing state.

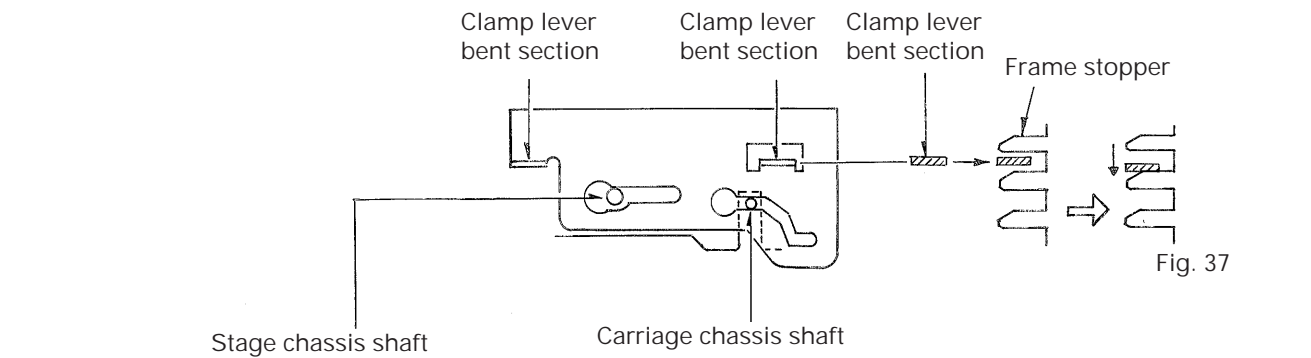

Fig. 37

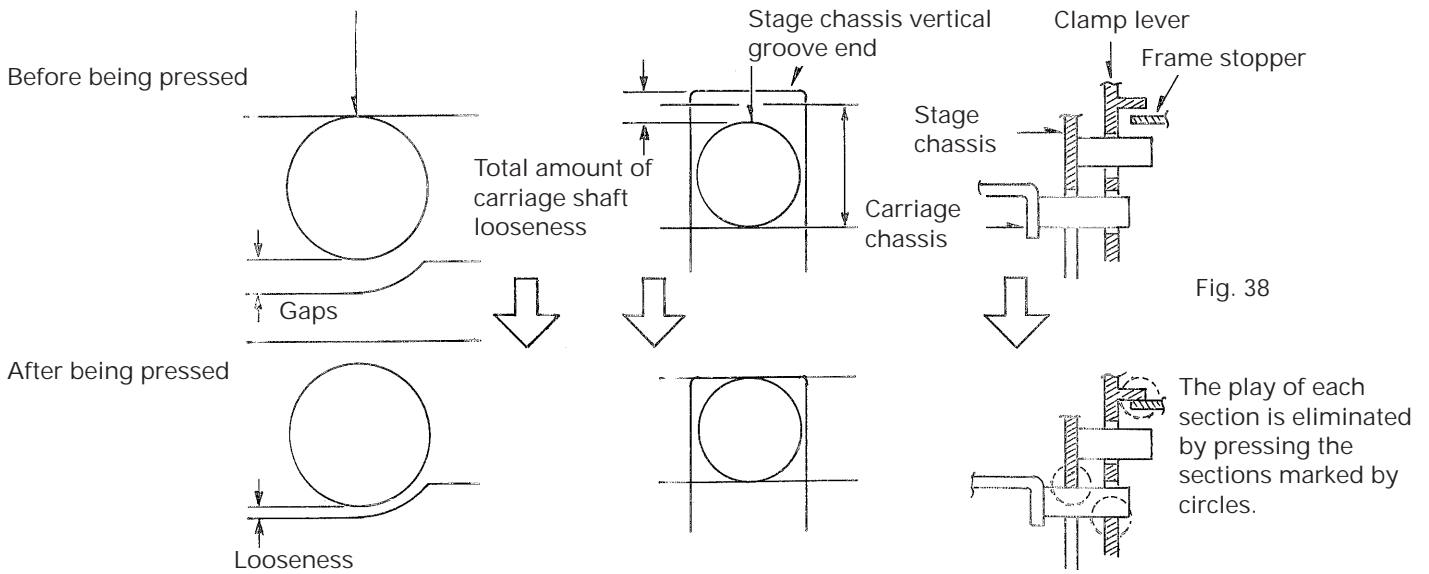

Fig. 38

The play of each section is eliminated by pressing the sections marked by circles.

● Disc detection

Fig. 39

The cam gear for tray extraction operation moves the DSP switch lever to turn the DSP switch (S852) ON and OFF. The photo sensors (Q851 and D852) detect the presence of discs and their types (8 or 12 cm) with a certain timing.

● Detecting Tray Extraction and Return

A) Tray extraction (Fig. 40)

The clamp joint arm moves the clamp lever and performs clamping. After clamping has been completed, the protrusion on the clamp joint arm presses the TRP switch (S851) via the TRP switch (S851) via the plate spring on the DSP switch lever and turns on the switch.

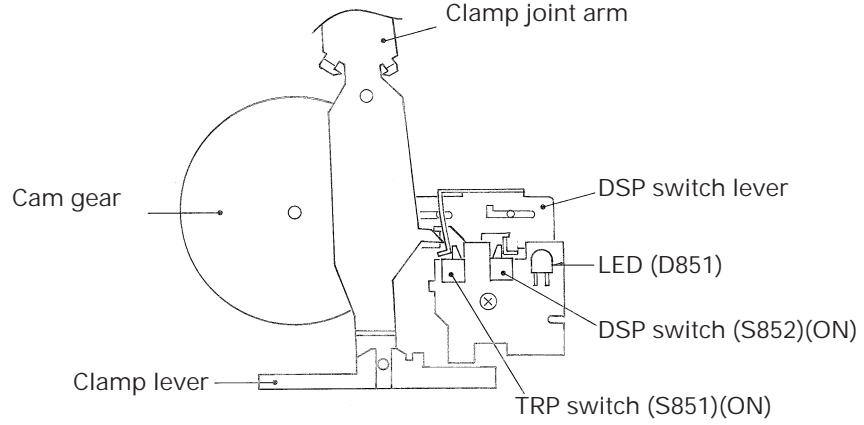

Fig. 40

B) Tray return (see Fig. 41)

The TRP switch (S851) is turned on by the DSP switch lever moved by the cam gear.

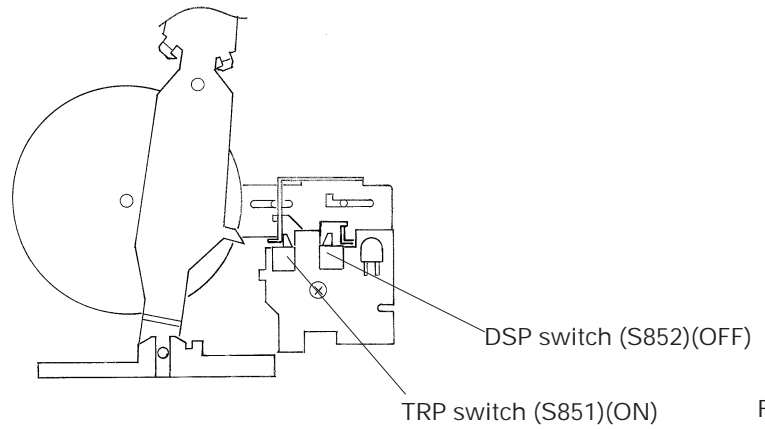

Fig. 41

● Tray Lock Mechanism

In other modes than the PLAY mode, the tray bouncing prevention spring is deflected by the rear lever and functions as a stopper to prevent the tray from coming out of the magazine. (Fig. 43)

In the PLAY mode, the window in the rear frame catches the projection of the tray bouncing prevention spring. Accordingly, the spring is not deflected to enable the tray's insertion and extraction. (Fig. 42)

Consequently, in other modes than the PLAY mode (during the waiting mode), the tray will not come out of the magazine even if external shock is applied to it. (Fig. 43)

When set in the PLAY position

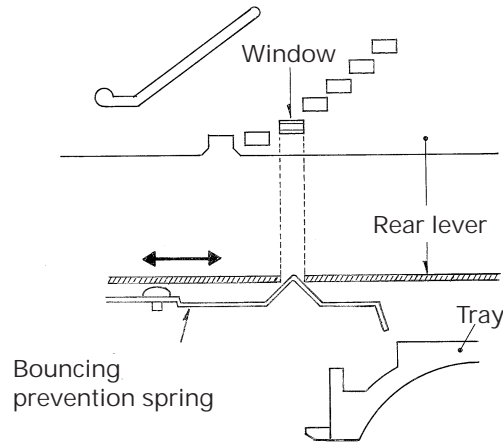

Fig. 42

When set to a position other than PLAY

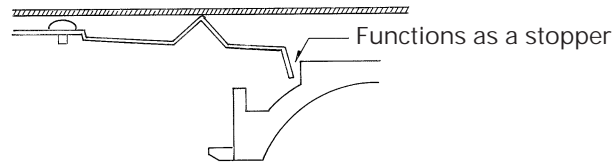

Fig. 43

● Ejecting the Magazine (see Fig. 44)

When the rear lever is further driven from the uppermost stage position of the elevation, the bent end face of the rear lever presses the boss on the lock arm to release the lock and the magazine is ejected by the EJECT lever.

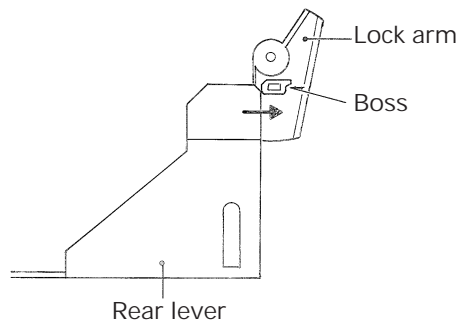
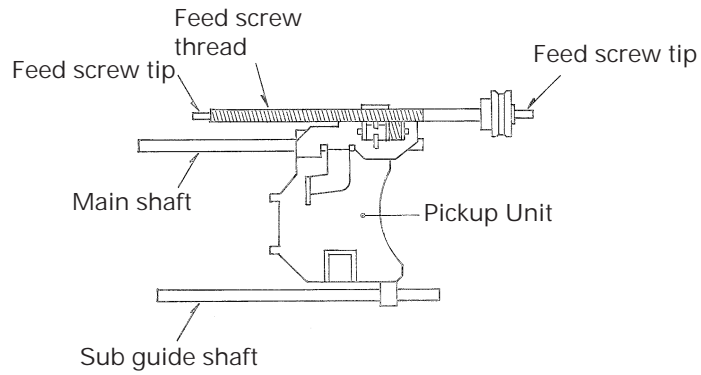

Fig. 44

● Lubrication points (Fig. 45)

(1) Around the pickup assy ->
Use EM-60L for all points.



(2) Slide section with clamp ball

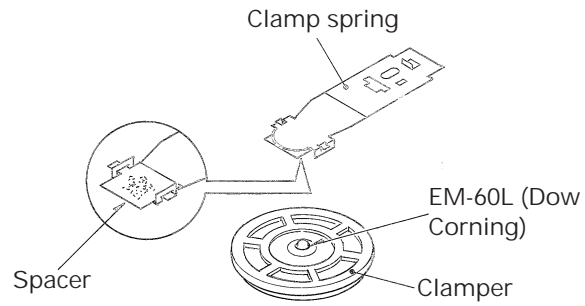

(3) For the other sections, use the E paste.

Fig. 45