

# *Service Manual*

ORDER NO.  
**CRT2503**

CD MECHANISM MODULE

# **CX-961**

- This service manual describes the operation of the CD mechanism module incorporated in models listed in the table below.
- When performing repairs use this manual together with the specific manual for model under repair.

Model	Service Manual	CD Mechanism Module
DEH-P90DAB/EW, ES	CRT2556	CXK5301

## **CONTENTS**

1. CIRCUIT DESCRIPTIONS .....	2
2. MECHANISM DESCRIPTIONS.....	15
3. DISASSEMBLY .....	17

# 1. CIRCUIT DESCRIPTIONS

This unit is roughly divided into the preamplifier stage, servo unit, power supply unit and loading control unit. This LSI (large scale integrated circuit) implements eight automatic adjustments according to the combination of the preamplifier stage and servo unit used.

Besides, because this system conforms to the single power supply (+5 V) specifications, the reference voltages of servo systems (preamplifier, servo DSP and pickup) are all  $V_{ref}$  (2.1 V).

## 1.1 Preamplifier (TA2150FN; IC201)

The preamplifier processes output signal from the pickup, then generates signals to the servo unit, demodulator unit and control unit at the next stage, and controls power for the pickup's laser diode. The signal from the pickup is I-V converted by the preamplifier built into the pickup's photodetector, then added by the RF amplifier to obtain such signals as RF, FE and TE.

Reference voltage  $V_{ref}$  (2.1 V) is output from pin 19 of this IC and  $2 V_{ref}$  (4.2 V) is supplied as the reference voltage which determines the D range of the servo DSP A/D input.

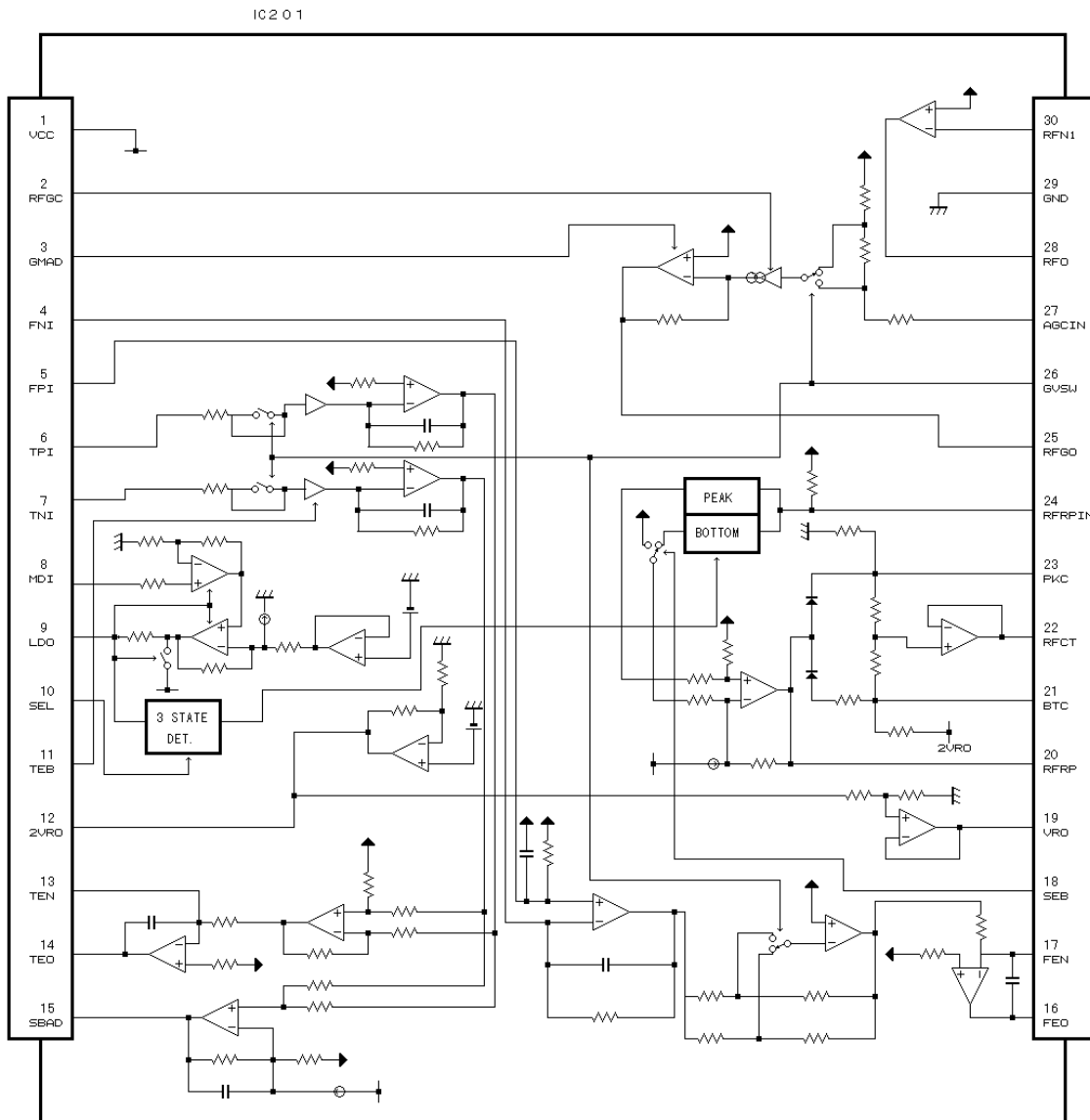

Fig.1:TA2150FN CIRCUIT

1) Focus error amplifier unit

This focus error amplifier outputs photodetector output (A + C) or (B + D) from pin 16 of IC201 (TA2150FN) via a differential amplifier and an error amplifier assuming (A + C - B - D) as an FE signal. The low frequency component of voltage FE is expressed as

$$FE = (A + C - B - D) \times (150\text{ k} / 62\text{ k}) \times (60\text{ k} / 60\text{ k}) \times (12\text{ k} / 60\text{ k}) = 4.84\text{ times.}$$

An S curve of approximately 1.45 Vpp is obtained in the FE output on the basis of Vref. The cutoff frequency is 26 kHz or 133 kHz.

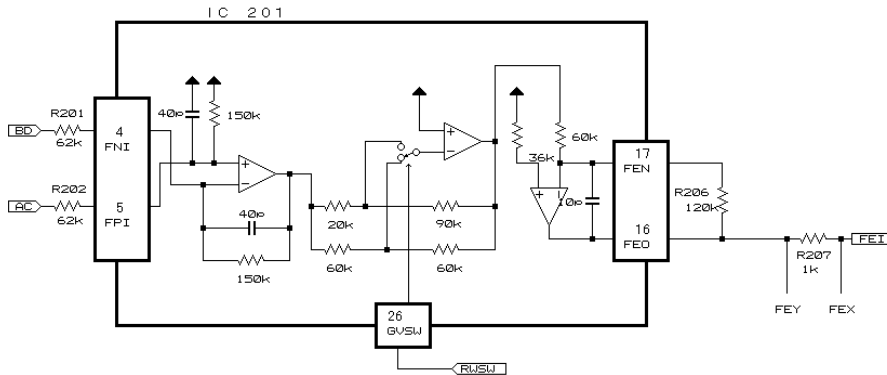

Fig.2:FE CIRCUIT

2) Tracking error amplifier unit

This tracking error amplifier unit outputs photodetector output E or F from pin 14 of IC201 (TA2150FN) via an amplifier and an error amplifier assuming (E - F) as a TE signal. The low frequency component of voltage TE is expressed as

$$TE = (E - F) \times 300\text{ k} / 100\text{ k} \times 155\text{ k} / 328\text{ k} \times 82\text{ k} / 20\text{ k} = 5.8\text{ times.}$$

A TE waveform of approximately 1.51 Vpp is obtained in the TE output on the basis of Vref. The cutoff frequency is 44.5 kHz or 29.4 kHz.

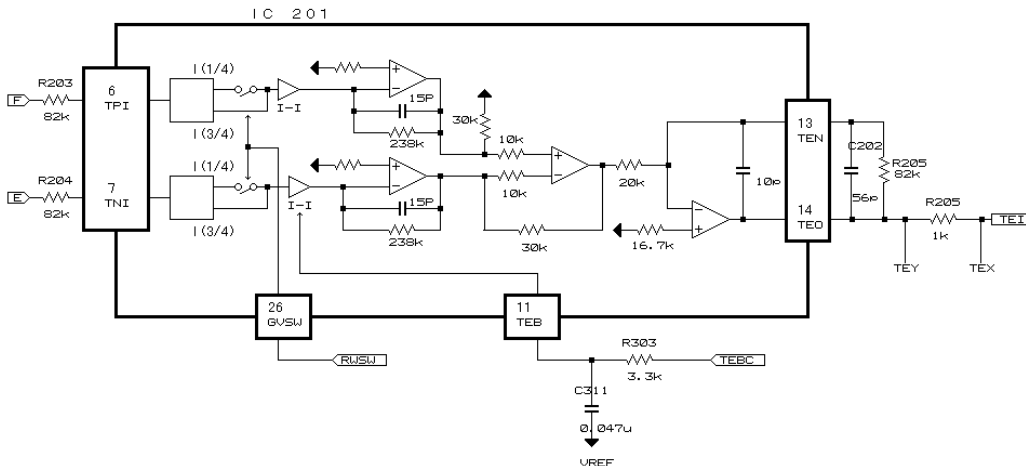

Fig.3:TE CIRCUIT

### 3) RF amplifier unit

The head amplifier LSI, TA2150FN, adds, amplifies and equalizes photodetector output (A+C) and (B+D), then outputs RF signal to the RFI pin. (This signal enables checking eye patterns.) Low frequency element contained in RFI voltage is formulated as follows:

$$RFI = (A + B + C + D) \times 5.43.$$

RFI is used for RF Offset Control circuit. RFI signal output from Pin 28 is AC-coupled externally, and then re-input to Pin 27 and amplified by the RFAG amplifier to obtain RFO signal.

As described later, TA2150FN has a built-in RFAGC function that controls the RFAGC amplifier gain so that RFO output stays within  $1.2 \pm 0.3V$  p.p. range.

This RFO signal is used for EFM and RFAGC control circuit and for generating RFRP and RFCT signals for track counting.

Besides, the frequency characteristics of an RF equalizer are switched at double-speed reproduction. (Switching using the HSSW terminal)

Further, with RWSW the gain at the RF amplifier stage is raised by 13db, compared with that in normal operation, when the gain lowers because of stains on the lens or while playing a CDRW.

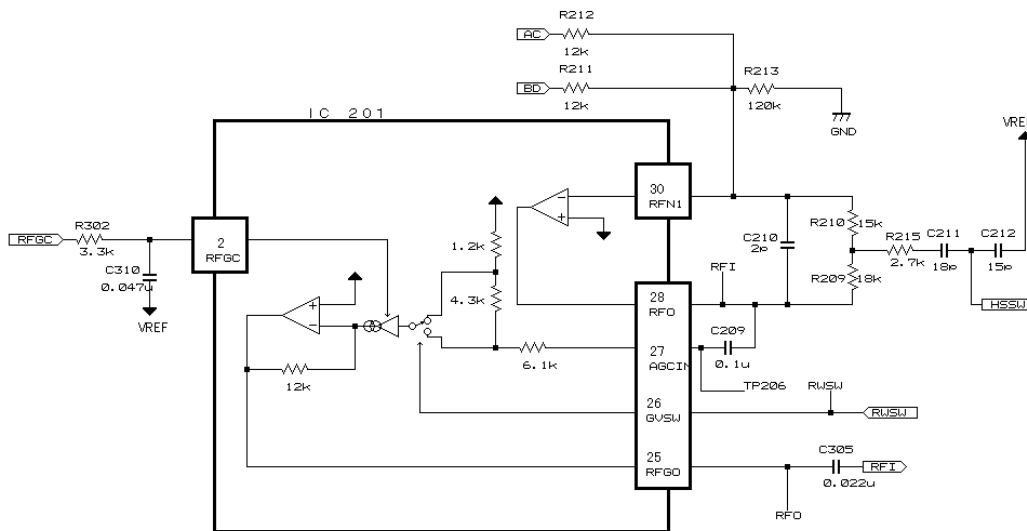

Fig.4:RF CIRCUIT

4) RFRP and RFCT signal circuit unit

The RFCT signal which is the difference signal between the peak and bottom levels of the RF signal is generated through head amplifier (IC201). RFRP and RFCT can be monitored at TP203 (pin 20 of IC201 TA2150FN) and TP204 (pin 22 of IC201) respectively.

The TE, RFRP and RFCT signals are compared by a hysteresis comparator inside IC301 (TC9495FP) respectively and generate track information (TEZC signal or RFZC signal). Based on this signal, the traveling speed information about a lens disk is generated and the number of tracks is counted.

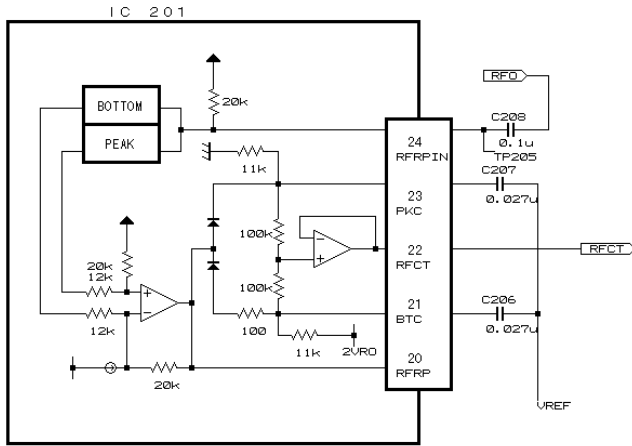

Fig.5:RFRP AND RFCT SIGNAL CIRCUIT

5) SBAD signal circuit unit

This SBAD signal circuit unit outputs photodetector output E and F from IC201 (pin 15 of TA2150FN) via an addition amplifier assuming (E + F) as an SBAD signal. This SBAD signal is used as the internal decision conditions of focus ON/OFF with a focus error signal. Further, the SBAD signal is also used for detecting defects when disk scratches are passed.

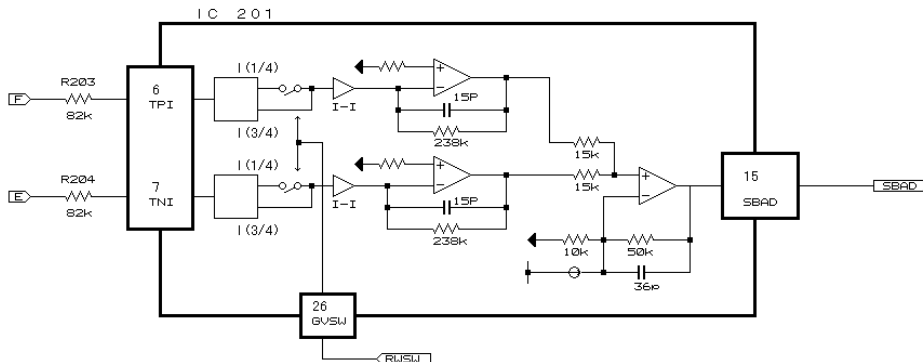

Fig.6:SBAD SIGNAL CIRCUIT

### 6) APC circuit section

A laser diode's driving current must be controlled so that optical output could remain constant by using a monitoring diode, because optical output has high negative characteristics that causes a heat hang-up if the laser diode were driven at constant current. This is exactly where APC circuit works. LD current can be obtained by measuring voltage between LD1 and GND, which value is about 35 mA at room temperature.

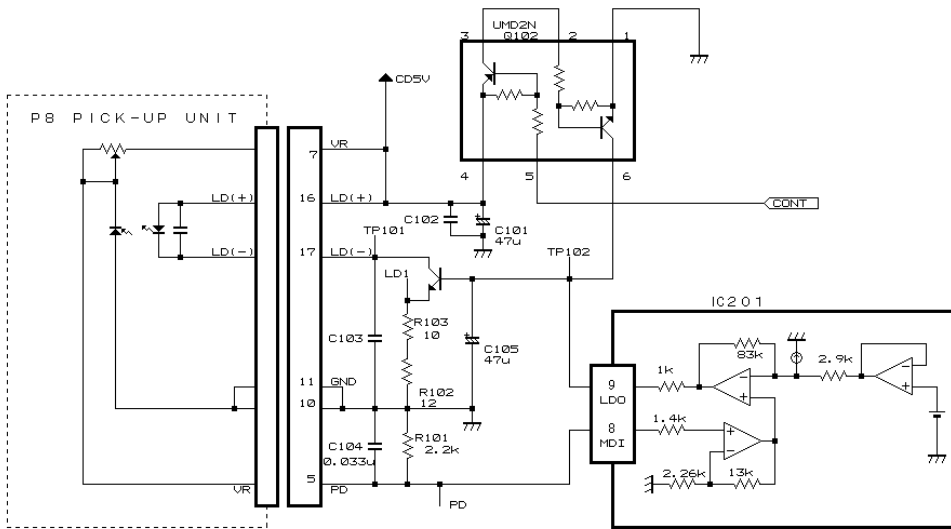

Fig.7:APC CIRCUIT

## 1.2 Servo DSP (TC9495FP; IC301)

### 1) Focus servo system

The main equalizer of the focus servo is comprised with a digital equalizer unit. Fig. 8 shows a block diagram of the focus servo.

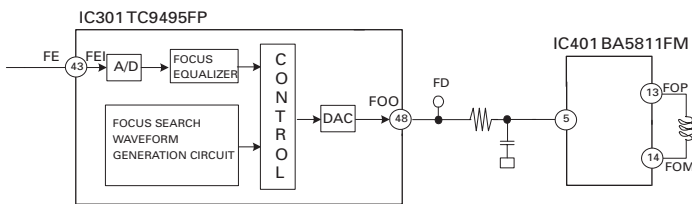

Fig.8:FOCUS SERVO CIRCUIT BLOCK

The operation of detecting an adjusted focus point and turning on the focus servo is called focus search. In a focus servo system, a lens needs to move to the adjusted focus point to enable focus close. Accordingly, the adjusted focus point is detected by moving the lens up and down according to the focus search voltage of a triangular wave. Further, in the meantime, a spindle motor enters the simplified FG mode and maintains a constant speed of rotation. The focus servo turns on under the following three conditions:

1. FOK = H
2. A focus error signal exceeds a focus standby level threshold.
3. A focus error signal reaches a zero cross.

At this time, while the lens is fully separated from the adjusted focus point, cancel the SBAD offset and set this level to SBOFF. If the SBAD level exceeds the FOK threshold from the SBOFF standard, FOK = "H" is set.

When the lens moves up and down, a focus error signal changes at the adjusted focus point. However, CD-LSI removes an offset component by passing through a bypass filter after it has A/D-converted this error signal. When this FEHPF signal (LSI signal) level exceeds a focus standby high level, the servo standby state occurs because the adjusted focus point approaches. Subsequently, the FEHPF signal reaches the adjusted focus point and turns on the focus servo.

The microcomputer monitors an FOON signal (Active at servo ON; L for a probe) at focus search, and starts monitoring a FOK signal in 40 ms after it has been set to Active). If it is judged that FOK is not active, the microcomputer performs protection operation. Besides, when the Focus Close button is pressed with the focus mode select set to Display 01 in the test mode, a focus error, search voltage and the action of a practical lens can be checked.

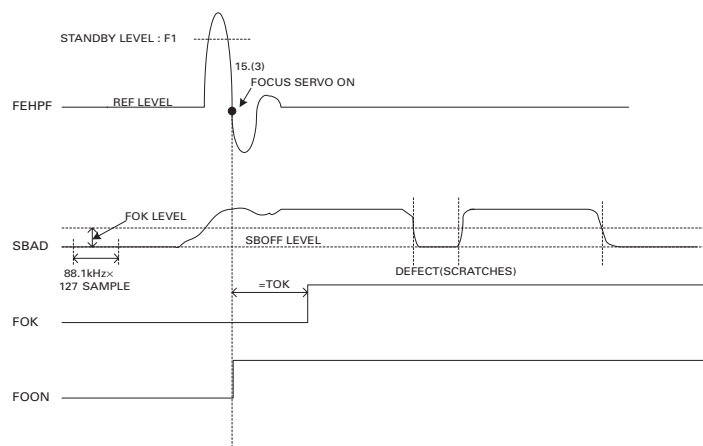
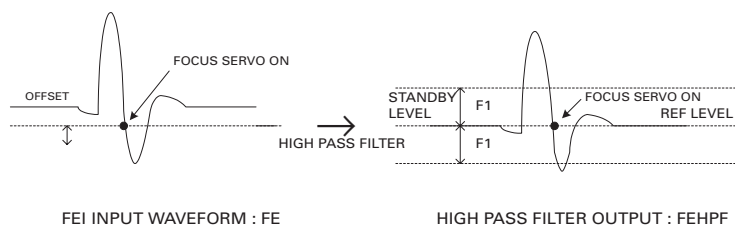

Fig.9:FOCUS SEARCH TIMING

## 2) Tracking servo system

The main equalizer of the tracking servo is comprised with a digital equalizer unit. Fig. 10 shows a block diagram of the tracking servo.

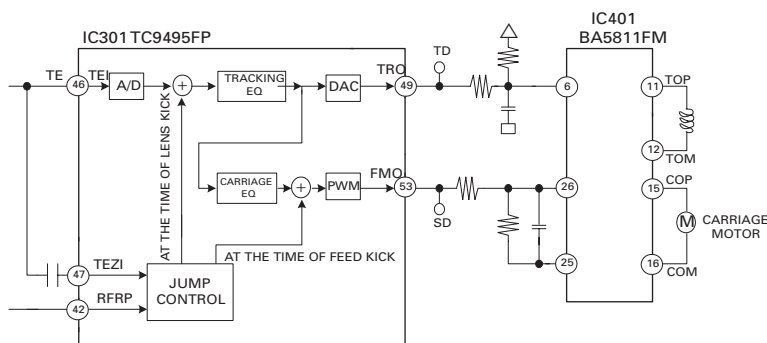

Fig.10:TRACKING SERVO CIRCUIT BLOCK

• Track jump

A track jump is automatically performed with a microcomputer command using the LSI auto (automatic) sequence function.

This system has one to 99 lens kick modes as the track jump used at search and the carriage move used in the jump exceeding 1,000 tracks. The test mode can check the jump of lens kick modes 1, 32 and 99 and the carriage move according to the mode selection.

• Lens kick Jump

Lens Kick jump is executed as soon as the LSI receives the Lens Kick command from the microcomputer. The direction of jump and the number of tracks are determined by the command's parameters. When the LSI receives the Lens Kick command, the jump is performed by inputting a kick pulse to the tracking EQ. The LSI controls lens traveling speed, referencing to the table held internally. By doing so, the lens travels faster when there are a good number of tracks to go, while the lens traveling speed gets slower as the remaining tracks decrease. After track count has been completed, tracking close is performed. During jump, an RFRP signal is watched to perform track count and the direction of the jump is detected according to the phase of RFRP or TEZI. Besides, to improve the servo feed at track jump, the tracking servo gain increase and hysteresis operation are performed for 50 ms after tracking close has been completed. The FF/REV operation in the normal mode is implemented by continuously performing a single jump. The speed is about 10 or 20 times the normal mode. (It depends on destinations).

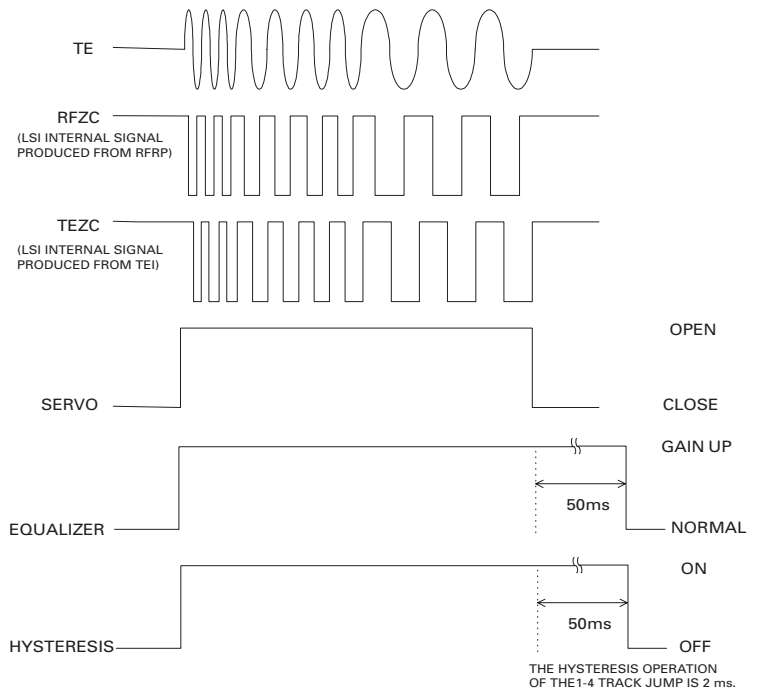

Fig.11:LENS KICK

• Carriage move jump

A carriage move jump is executed by issuing a carriage move command from the microcomputer. The direction of the move and the number of tracks are specified with the command. When the LSI accepts the carriage move command, the jump is performed by opening the tracking servo, applying a kick signal to the carriage equalizer and driving the carriage motor. The profile of a signal applied in this time is provided with a time constant at rise time. As the remaining tracks decrease, voltage is lowered that results in slower carriage traveling speed.

The servo feed at the end of the jump is improved by reducing the speed in this manner immediately before the jump terminates.

Besides, to improve the servo feed at the end of the jump, the tracking servo gain increase and hysteresis operation are performed for 60 ms after the jump has been performed.

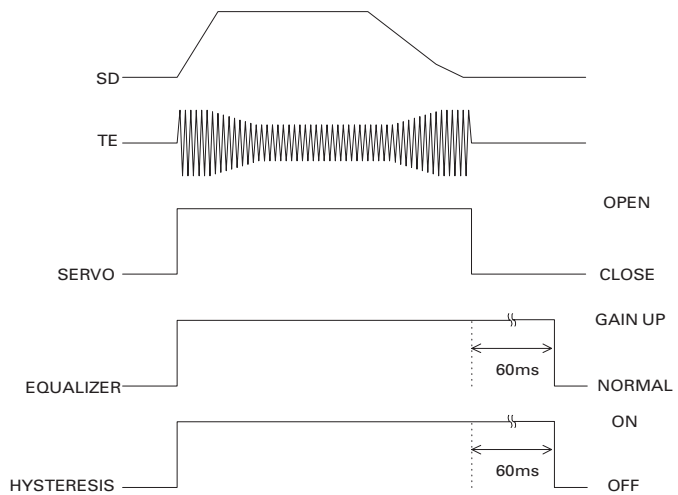

Fig.12:CARRIAGE MOVE



• Hysteresis operation

Because the servo feed is deteriorated at setup and track jump, hysteresis is operated to perform a servo feed to a stable servo loop. The hysteresis operation holds a TE signal and improves the convergence of the tracking servo when a beam spot arrives at an off track.

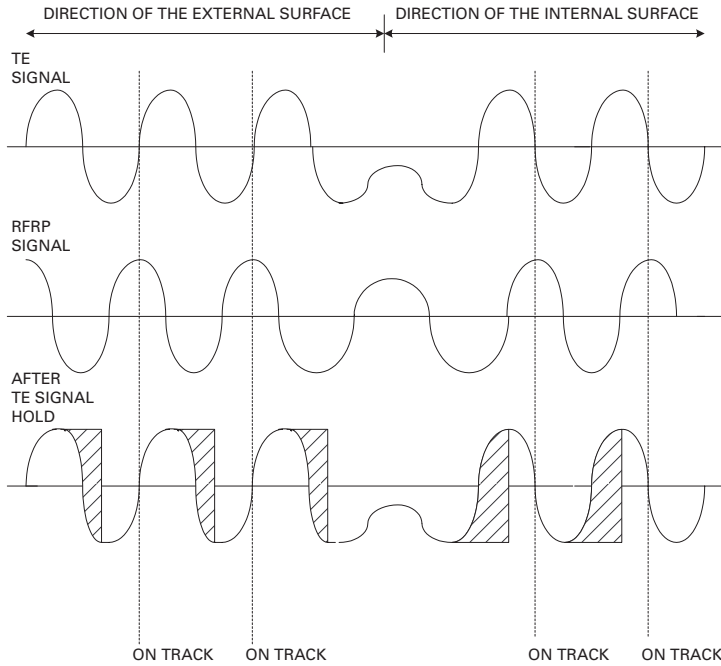

Fig.13:HYSTERESIS OPERATION

3) Carriage servo system

The carriage servo inputs the output of the low frequency component (lens position information) of the tracking equalizer, and outputs a drive signal from the LSI after a fixed gain has been obtained. The signal further applies to the carriage motor via the driver. Specifically, because the entire pickup needs to move to the forward direction when the lens offset during play reaches a certain level, the gain of the equalizer is set so as to output a higher voltage than the starting voltage of the carriage motor at that time. Besides, as a practical operation, only when a threshold level against the equalizer output is exceeded inside the servo LSI, a drive voltage is output. The threshold level is set slightly higher than the starting voltage of the motor to reduce power consumption and stabilize operation. This drive output waveform has a pulse shape.

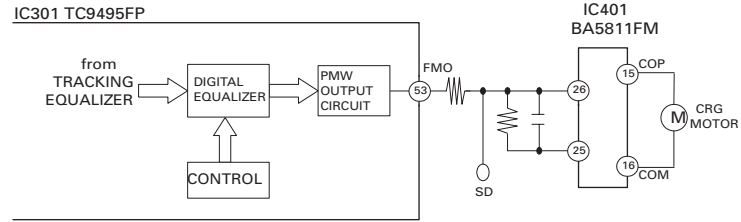

Fig.14:CARRIAGE SERVO CIRCUIT BLOCK

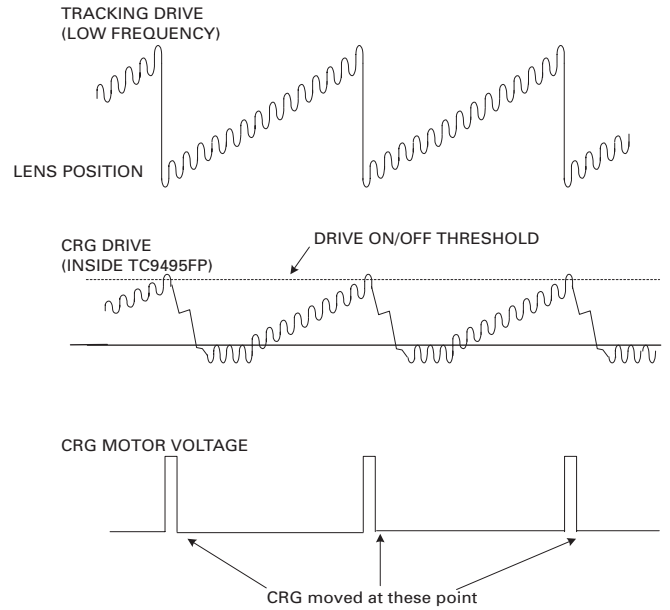

Fig.15:CARRIAGE SIGNAL WAVEFORM

4) Spindle Servo System

Fig. 16 shows a block diagram of the spindle servo.

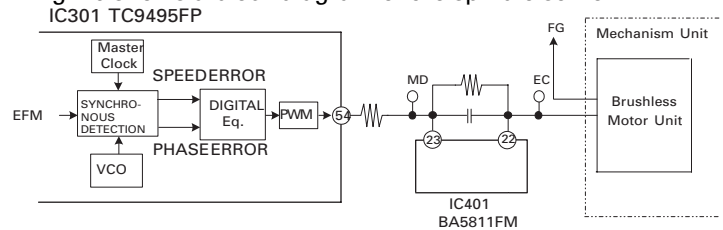

Fig.16:SPINDLE SERVO CIRCUIT BLOCK

The spindle servo has the following modes:

- CLV servo

This CLV servo mode is the servo until the brake is applied to stop the disk after focus close. The spindle servo operates in this mode before tracking close and at normal reproduction.

In the EFM demodulation block inside the CD-LSI, the spindle servo performs synchronous detection and operates so as to be kept in a specified speed of rotation. The synchronous detection is also enabled before tracking close by using the VCO speed control of the inside of the LSI in the PLL circuit. After tracking close, the VCO speed control is muted and switched to the speed and phase control by a master clock (a ceramic oscillator is used).

• Simplified FG servo mode

This simplified FG servo mode is used to maintain the number of disk rotations in the state of the approximate number of regular rotations. In this mode, controlling driving voltage for the spindle motor is enabled by letting the microcomputer monitor FG signal that outputs pulses based on the number of rotations. The mode is used in the following conditions:

- a) Until focus close is performed from POWER ON at setup
- b) Until focus is out of order during play and recovered later

• Brake mode

This brake mode is used to stop the spindle motor. The brake sequence is started by issuing a CD-LSI command from the microcomputer. The LSI sets a flag on by detecting that the number of disk rotations was set to approximately one twentieth. This flag is monitored by the microcomputer to set the servo off. When no flag is set on even if a fixed time elapses, the brake mode enters the stop mode until it is checked that the rotation was delayed by monitoring the FG pulse. If the mode is switched to the stop mode at ejection, the operation moves to the ejection operation after the timeout time elapses.

• Stop mode

This stop mode is used at POWER ON and ejection. The drive output is 0.

- (2) Calculate voltage to be offset based on the value read into earlier, and then assign the offset value to the given location. Besides, because this adjustment is performed inside a digital filter, no change cannot be found as an error offset voltage after adjustment.

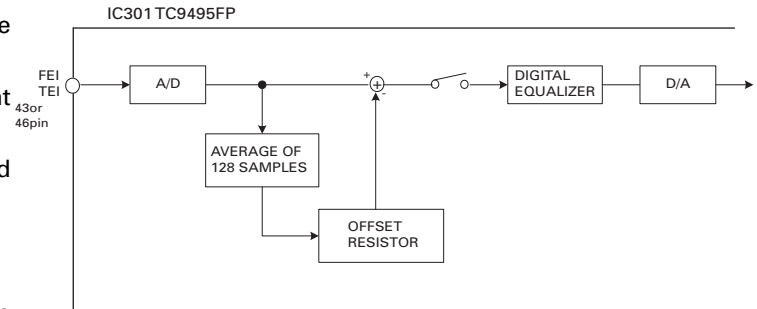

Fig.17:OFFSET ADJUSTMENT

### 1.3 Automatic Adjustment Function

This system automates all circuit adjustments inside CD-LSI (IC301: TC9495FP). All the adjustments are performed every time at disk insertion or source key CD mode selection.

The contents of each automatic adjustment are described.

#### 1) Automatic TE and FE offset controls

These controls are used, at powering on, to have the TE and FE amplifiers' offset value stay within the target range using Vref as a reference. (The target is (TE, FE) = (0, 0) [V]) respectively.

The adjustment procedures are as follows:

- (1) The servo LSI reads each offset of the laser diode OFF state.

#### 2) Automatic tracking balance (T. BAL) control

This control is used to equalize output difference between Ech and Fch from the pickup by adjusting the preamplifier's internal gain. In practice, a TE waveform is adjusted so as to become symmetric vertically for a servo reference level.

The adjustment procedures are as follows:

- (1) After focus close
- (2) Turn on the spindle servo.
- (3) Calculate a TE center value according to the introduced TE signal and TE offset levels in the LSI.
- (4) This center value changes the gain of the RF amplifier so as to approach to a servo reference level.

The servo reference level is as follows:

TEI input level at servo OFF (= TE offset level) when offset adjustment is performed

Vref level when no offset adjustment is performed

To improve adjustment accuracy, the adjustment is repeated several times.

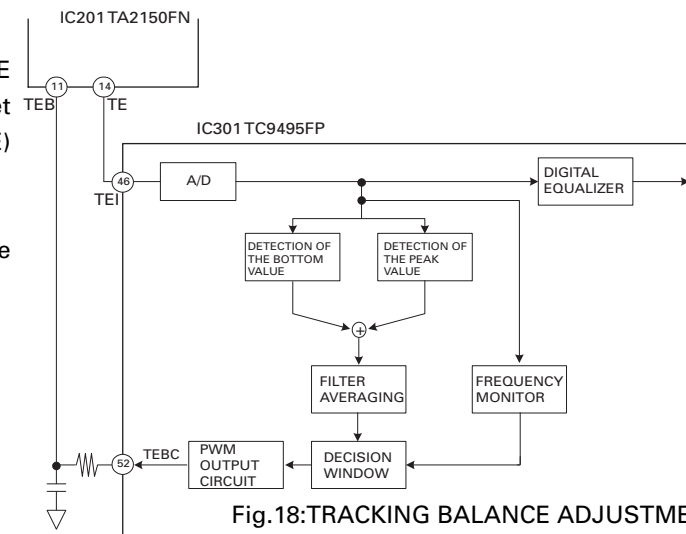

Fig.18:TRACKING BALANCE ADJUSTMENT

### 3) Focus or tracking AGC

This adjustment automatically adjusts the servo loop gain of focus or tracking AGC.

The adjustment procedures are as follows:

- (1) Inject disturbance into the servo loop.
- (2) Sample an error signal (FE or TE) via B. P. F at disturbance injection.
- (3) Compare the signal obtained as mentioned above inside the LSI and the phase with disturbance.
- (4) Adjust a phase difference so as to reach the target phase value set on the microcomputer.

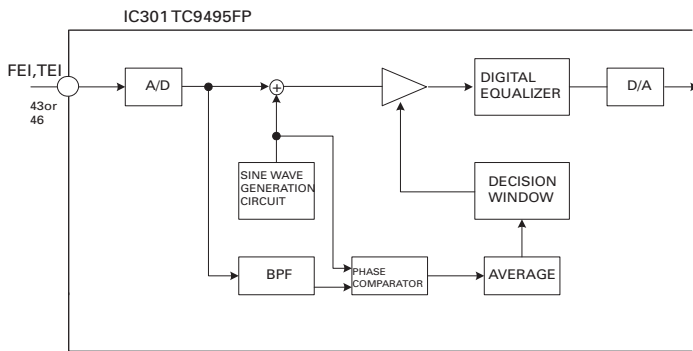

Fig.19:LOOP GAIN ADJUSTMENT

### 4) FE bias automatic adjustment

This adjustment maximizes an RFI level by optimizing the focus point during play and adjust the level using the RFRP level and phase difference at the disturbance input of a focus error.

The adjustment procedures are as follows:

- (1) Inject disturbance into the focus loop with a microcomputer command. (Inside the servo LSI)
- (2) Detect an RFRP signal level inside the LSI.
- (3) Process the relationship between the above RFRP signal and disturbance inside the LSI and detect the amount and direction of focus misalignment.
- (4) Substitute the detected results for the bias adjustment item inside the servo LSI.

Besides, this adjustment repeats a series of arrangements several times in the same manner as auto (automatic) gain control and improves adjustment accuracy.

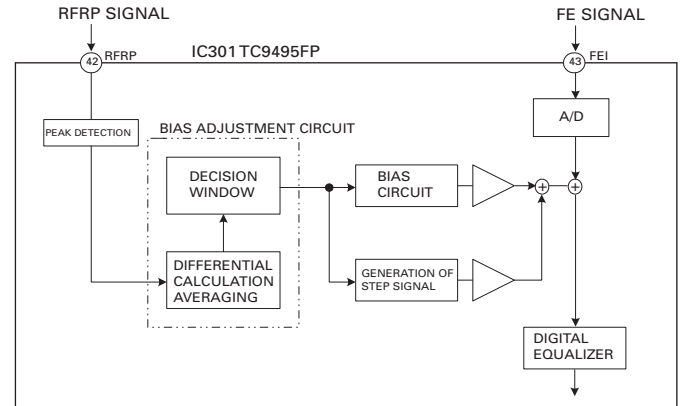

Fig.20:FE BIAS ADJUSTMENT

### 5) RF level automatic adjustment (RFAGC)

This adjustment adjusts unevenness of the signal (RFO) level caused by the factor of the mechanical unit and disk to a fixed value and is performed to aim at accurate signal transfer. The adjustment is performed by changing the amplifier gain between the RFI and RFO.

The adjustment procedures are as follows:

- (1) Calculate the PP level of RFRP from the peak and bottom values of the RFRP level inside the servo LSI.
- (2) Set such an amount of amplifier gain as a desired RFO level by being compared with the reference level and control the gain of the RF amplifier.

This adjustment is performed in the following timings:  
Immediately before setup completion (immediately before play)

Until focus was out of order during play and then is recovered

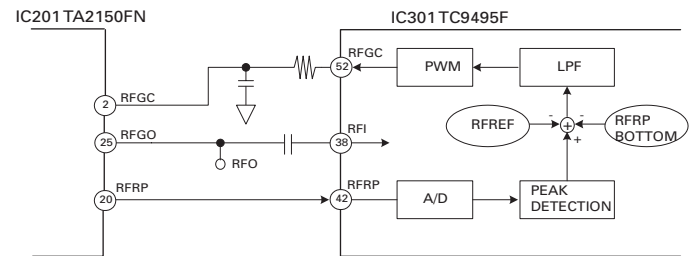

Fig.21:RF LEVEL ADJUSTMENT

### 6) Preamp stage gain adjustment

This adjustment increments 13 dB the gain of the entire FAMP (FE, TE and RE amplifiers) according to the setting of the GVSW terminal when there are few lens stains or there is remarkably little reflected light of a disk while playing the CD-RW.

The adjustment procedures are as follows:

If it is judged that the reflection of a disk is considerably small during setup, the entire RFAMP is incremented 13 dB by switching the GVSW terminal from "H" to "L". Besides, if the gain is changed, redo the setup from the first.

## 7) Adjustment initial value

All automatic adjustments are basically performed assuming the previous adjustment value as an initial value so long as the microcomputer power supply is not turned off (backup is not disconnected) (there are also several exceptions). If the backup is disconnected and the GVSW terminal is "L", the automatic adjustment is performed from the initial value instead of the previous adjustment value.

## 8) Coefficient display of adjustment results

For part of the automatic adjustments (FE or TE offset, T. BAL, F or T AGC, FE bias and RFAGC), the results can be displayed and checked in the test mode.

The coefficient display in each automatic adjustment is as follows:

### (1) FE or TE offset

Standard value = 32 (coefficient 32 indicates that no adjustment was necessary) and the display is performed in a unit of approximately 46 mV.

Example: For FE offset coefficient = 35,  
 $35 - 32 = 3 \quad 3 \times 46 \text{ mV} = 138 \text{ mV}$

The FE offset before adjustment is +138 mV.

### (2) T. BAL

Standard value = 32

Coefficient = 33 to 63 ..... TE: Top side - Bottom side < 0

Coefficient = 31 to 0 ..... TE: Top side - Bottom side > 0

Every time the coefficient moves by 1, misalignment changes by approximately 0.71 to 4.97%.

When the maximum misalignment on the positive side = coefficient 63, the misalignment is TYP (typical value) - 45%.

When the maximum misalignment on the negative side = coefficient 0, the misalignment is TYP (typical value) + 45%.

### (3) F or T gain adjustment

Standard value: Focus or tracking = 32, and the display is performed in a unit of approximately 0.375 dB.

Example: For AGC coefficient = 48,  
 $48 - 32 = 16 \quad 16 \times 0.375 \text{ dB} = 6 \text{ dB}$

The adjustment of +6dB (twice) was performed. ("A half loop gain was used originally, the entire gain was doubled to obtain a target value".)

### (4) FE bias

Standard value = 32, and the display is performed in a unit of approximately 21.5 mV.

Example: For EF bias coefficient = 35,  
 $35 - 32 = 3 \quad 3 \times 21.5 \text{ mV} = 64.5 \text{ mV}$

The FE bias alignment before adjustment results in +64.5 mV.

### (5) RF level adjustment (RFAGC)

Standard value = 32

Coefficient = 33 to 63 ..... Direction where an RF level increases (direction where a gain increases)

Coefficient = 31 to 0 ..... Direction where an RF level decreases (direction where a gain decreases)

Every time the coefficient moves by 1, the gain changes by approximately 0.07 to 0.15 dB.

When the maximum gain = coefficient 63, the gain is TYP (typical value) + 2.69 dB.

When the minimum gain = coefficient 0, the gain is TYP - 3.93 dB.

### 1.4 Power Supply Loading Unit

This system power supply uses VD (8.3±0.5 V) supplied from the mother substrate. The VD supply destination is a 5-ch CD driver IC or 5 V regulator IC. The power supply used inside the system is the two systems of the above VD (drive system), and V+5 (control system).

The ON/OFF other than the loading and ejection of the CD driver is controlled by the microcomputer with "CONT" and the 5V ON/OFF is controlled by the microcomputer with "CD5VON", respectively. For the ON/OFF of the loading drive, no control terminal is provided in particular, but input signal "CDEJET" or "CDLOAD" functions in the same way.

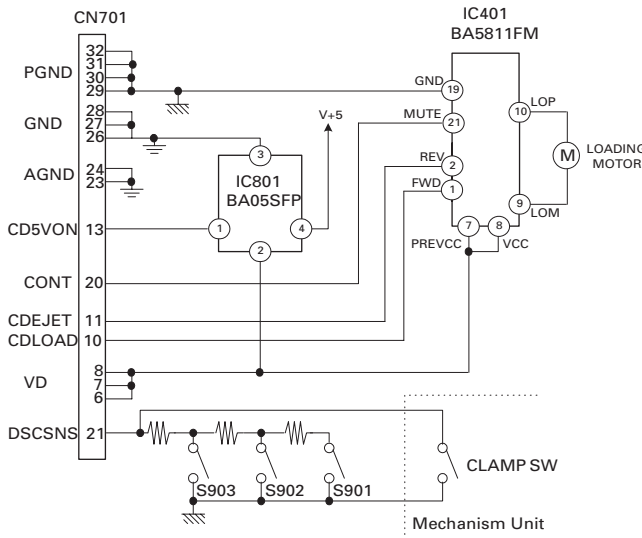

Fig.22:POWER SUPPLY / LOADING SYSTEM CIRCUIT BLOCK

The loading or ejection operation is controlled according to the state changes of the clamp switch on the mechanical unit and the three switches on the control unit. The DSCSNS voltage changes according to the ON/OFF states of these switches. For this voltage, each of states (A to E) is judged using the microcomputer A/D port. An eight/12 cm disk is judged according to this state transition. Fig. 23 shows each status and Fig. 24 shows the state transition.

DETECTION SWITCH STATUS AT THE TIME OF LOAD EJECTION

STATUS	A	B	C	D	E
SW1(S901)	ON	OFF	OFF	OFF	ON
SW2(S902)	OFF	OFF	ON	ON	OFF
SW3(S903)	OFF	OFF	OFF	ON	OFF
SW4(CLAMP SW)	OFF	OFF	OFF	OFF	ON
MECH. STATUS	NO DISK				CLAMP

Fig.23:DSCSNS STATUS

LOAD EJECTION OPERATING STATUS TRANSITION DIAGRAM

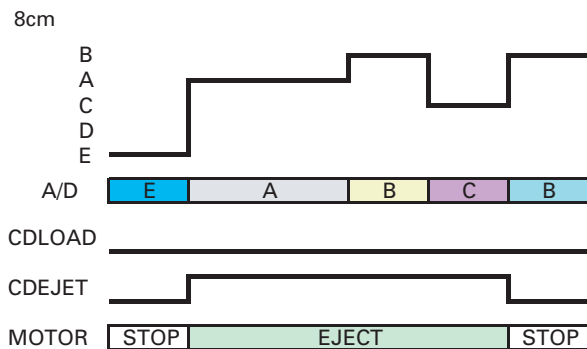
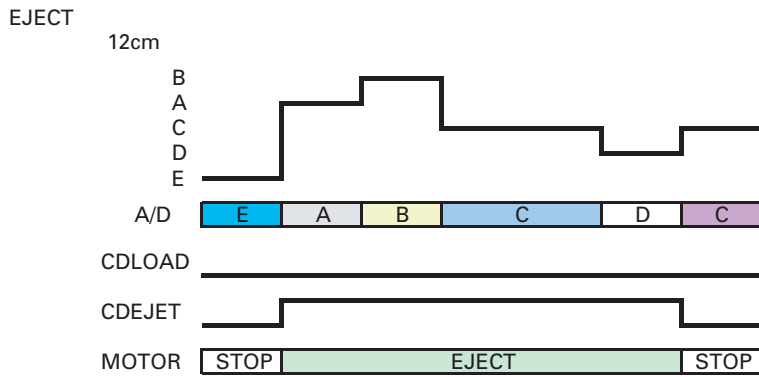
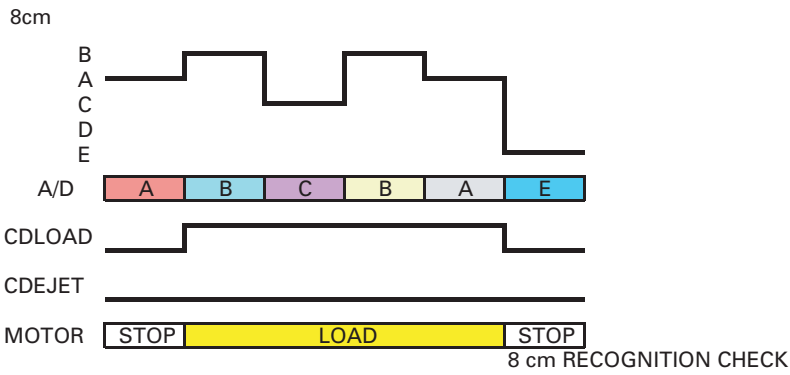
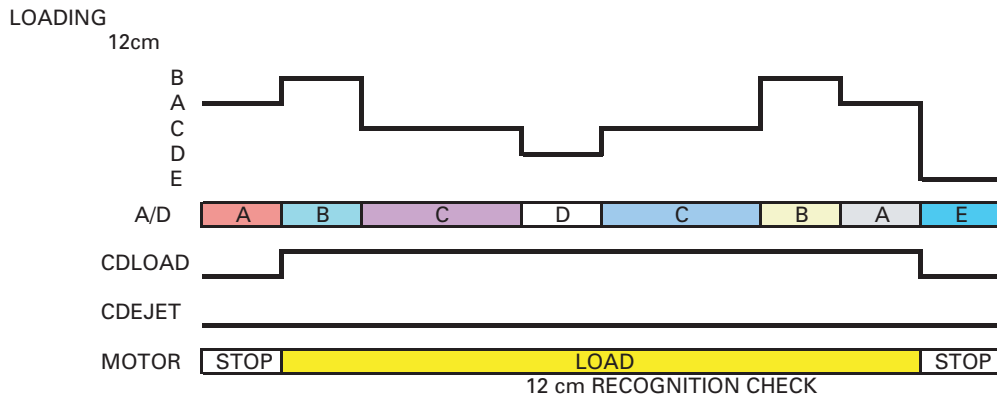
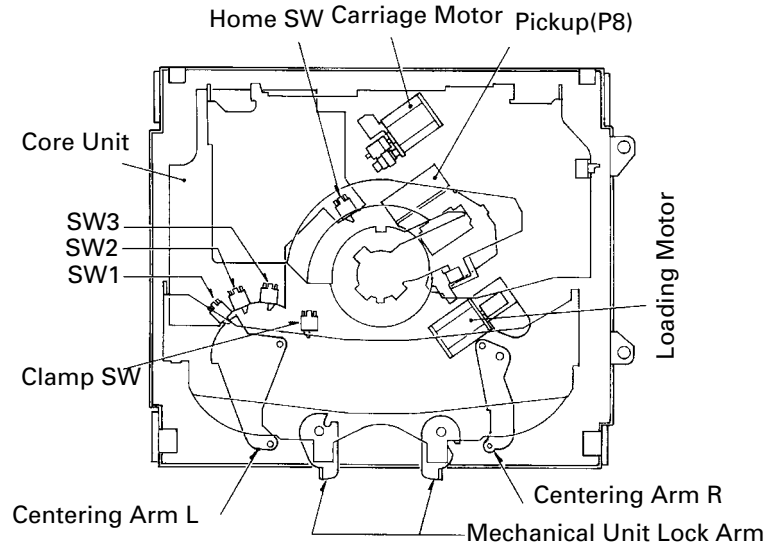

Fig.24:LOADING OPERATING STATE TRANSITION DIAGRAM

## 2. MECHANISM DESCRIPTIONS

### ● Configuration



### ● Loading operation

1. When a disk is inserted, the centering arm L or R rotates, and the loading motor starts when SW1 is switched from ON to OFF.
2. For a 12-cm disk, when the disk is carried to the position of a dashed line, SW3 is set to ON by the centering arm L, and the microcomputer judges the disk to be an 12-cm one.
3. For an 8-cm disk, the disk cannot approach to the position of a dashed line, and clamp operation occurs as is.

(Centering arms L and R are coupled. But even if only one side is pressed the arms cannot rotate beyond a fixed width as the coupling part is locked.)

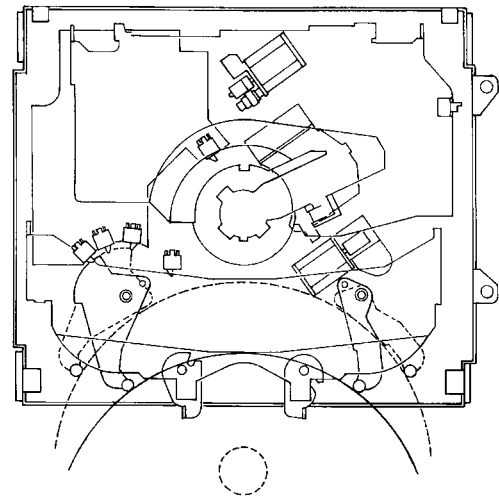

### ● Disk centering mechanism

1. When a 12-cm disk is carried to the position shown in the drawing, the centering guide relief arm rotates, holds the centering guide. And the centering guide is retreated from the disk trace.

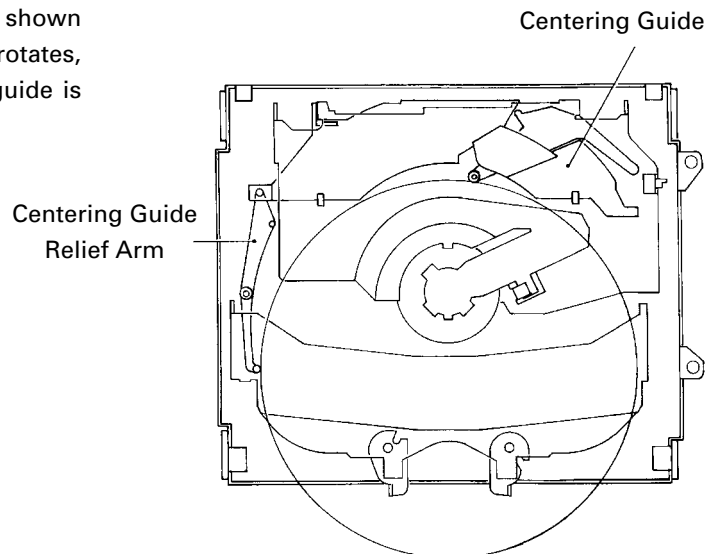

1. The centering guide is supported on the shaft at the clamp arm rear part and the front part is energized to the bottom.
2. For an 8-cm disk, the disk is centered at the position where it runs against the centering guide front part as is, and clamp operation occurs.
3. For a 12-cm disk, the centering guide front is held by the centering guide relief arm. The disk passes through under it and is centered at the mechanical unit depth position, and clamp operation occurs.

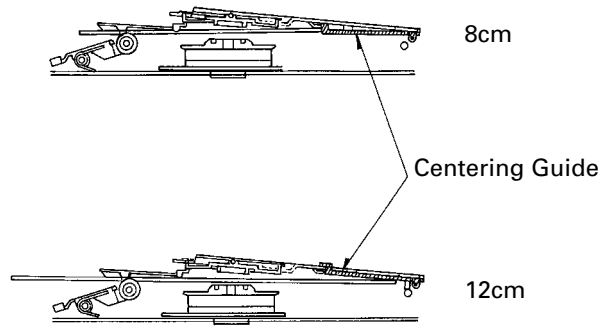

● **Clamp operation**

1. 8-cm and 12-cm disks drive the detection arm at the centered position on the spindle, and start the disk clamp operation by engaging the rack arm and drive gear.
2. The mechanical unit lock lever moves to the arrow view direction and releases the coupling between the mechanical unit lock arm and frame. Further, it completes clamp operation at the position where the clamp SW is set to ON.

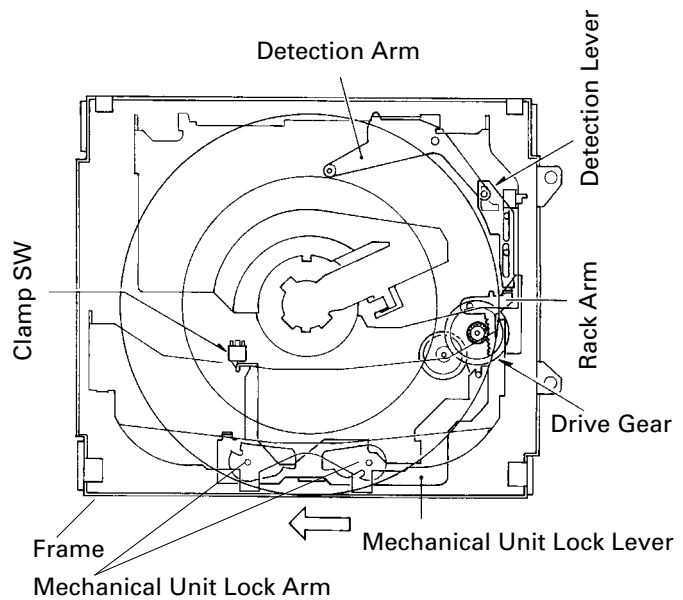

● **Ejection operation**

1. The loading motor rotates backward and the ejection operation starts.
2. A 12-cm disk completes ejection operation when SW3 is set from OFF to ON to OFF in this order.
3. An 8-cm disk completes ejection operation when SW2 is set from OFF to ON to OFF in this order.

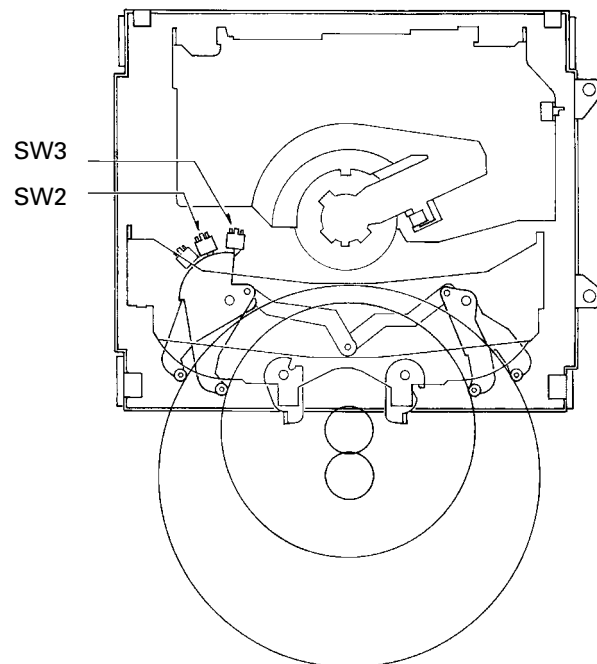



### 3. DISASSEMBLY

The numeral enclosed by a circle in the drawing indicates the order of removal.

#### ● How to hold the mechanical unit

1. Hold the top frame and main frame.
2. Do not hold the front of the top frame tightly because its strength is low.

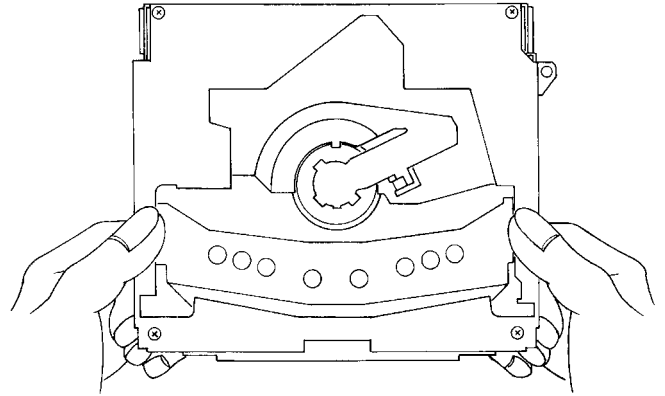

#### ● How to remove the top frame and main frame

1. Remove the four screws and four springs of the top frame in the clamped state and remove the top frame.
2. After having removed the screws of the two dampers and the dampers on the right, remove the main frame.
3. Remount the product connector with the frame removed and eject a disk.

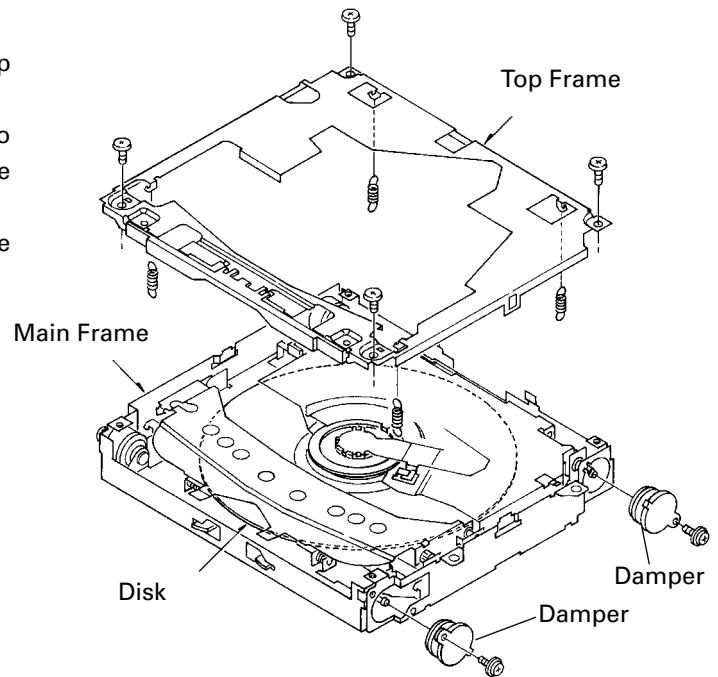

#### ● How to remove the clamper arm assy and guide arm assy

1. Remove a total of three right, left and rear springs and remove the clamper arm assy.
2. Remove the left spring and remove the torsion spring hook of the right fulcrum part.
3. Remove the E ring of the left fulcrum and remove the guide arm assy.

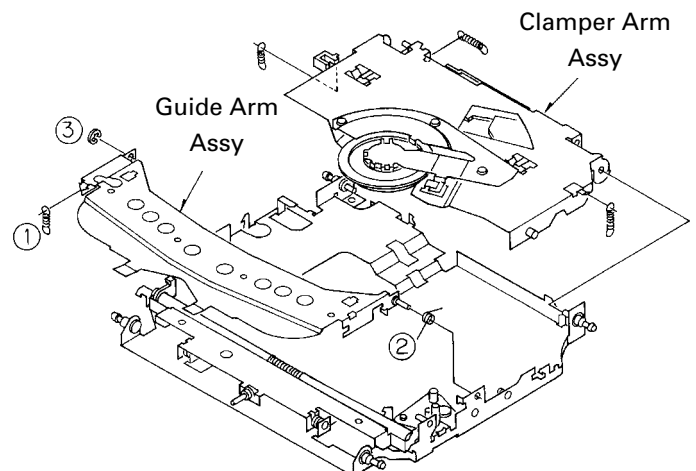

● **How to remove the loading arm assy and spindle motor**

1. Remove the E ring of the left fulcrum and remove the springs and loading arm assy.
2. Remove the connector of the spindle motor and remove the mounting three screws.

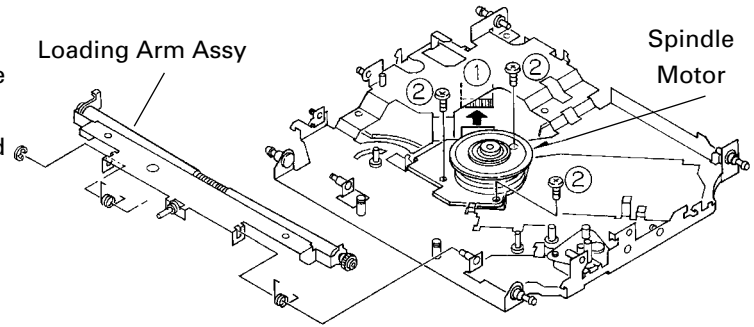

● **How to remove the loading motor assy**

1. Remove the gear cover screw and remove the gear cover.
2. Remove the holder which was tightened together with the gear cover.

(Note):

At assembly, tighten the holder together with the gear cover by approaching the holder to the arrow view direction and touching the tip of the motor shaft.

At this time, screwing with the holder being pressed tight causes higher motor load (this may cause a malfunction), therefore tighten screws with the hand off from the holder, having the holder touching to the motor spindle edge.

3. Remove the solder of the motor lead wire.
4. Remove the leaf spring screw and remove the holder and leaf spring.
5. Put the mechanical unit face downward, remove the mounting screws of the loading motor assy and remove the loading motor assy.

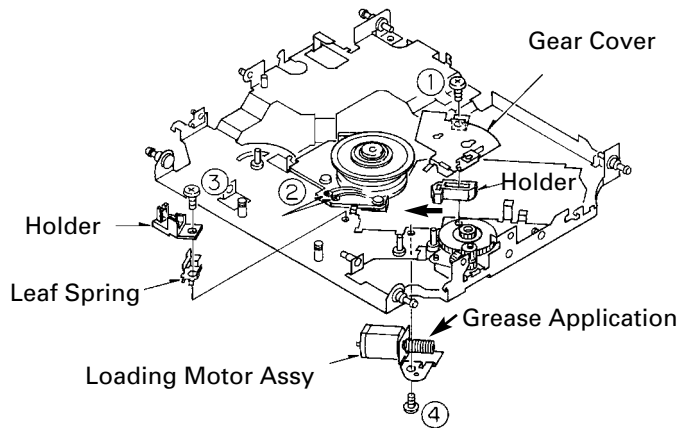

● **How to remove the carriage motor assy**

1. Remove the solder of the carriage motor lead wire.
2. Remove the grease cover screw and remove the grease cover.
3. After having removed the lead wire processing of the motor, remove the mounting screw of the carriage motor assy.

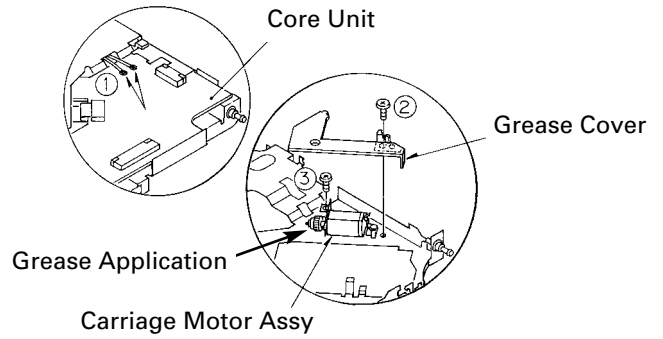

● **How to remove the pickup**

1. Mount the jumper pin and remove the pickup connector.
2. After having removed the processing of flexible wires, remove the mounting screw of the main shaft holder and remove the pickup together with the main shaft holder and the main shaft.

