

Service Manual

**CIRCUIT & MECHANISM
DESCRIPTIONS
REPAIR & ADJUSTMENTS**

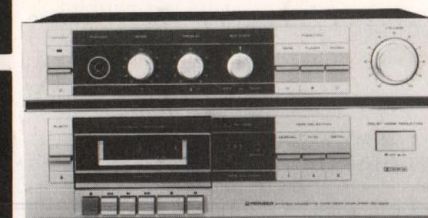

**ORDER NO.
ARP-505-0**

STEREO CASSETTE TAPE DECK AMPLIFIER

DC-100Z DC-101Z

- DC-101Z differs from DC-100Z in style design (color).
- Models DC-100Z and DC-101Z come in versions distinguished as follows:

Type	Applicable model		Power requirement	Destination
	DC-100Z	DC-101Z		
HE	○	—	AC220V (240V)*	European continent
HB	○	○	AC240V (220V)*	United Kingdom
HP	○	—	AC240V (220V)*	Australia
HEZ	○	—	AC220V (240V)*	West Germany
KU	—	○	AC120V only	U.S.A.
KC	—	○	AC120V only	Canada
S	○	○	AC110V/120V/220V/240V (switchable)	General market
S/G	○	—	AC110V/120V/220V/240V (switchable)	U.S. Military

*Change the primary wiring of the power transformer.

- This service manual is applicable to the HE type. For servicing of the HB, KU and HEZ types, please refer to pp. 48~56. For servicing of the other types, please refer to the additional service manual.
- For the mechanism descriptions, please refer to the DC-200Z service manual (ARP-504-0).
- Ce manuel d'instruction se réfère au mode de réglage, en français.
- Este manual de servicio trata del método de ajuste escrito en español.

QUESTIONNAIRE

MODEL _____
One Model per questionnaire

Dear Servicer,

Thank you for your cooperation in the post-sale service of Pioneer products.

This questionnaire is used as a tool to improve the serviceability of our products and service manuals. Please evaluate this model and service manual by answering the following questions. Your ideas may be realized in our future products. Your answers will be appreciated. Thank you.

PIONEER ELECTRONIC CORP.

T. Nakagawa, Manager, Service Section, International Division

1. SERVICING EVALUATION Circle applicable number: Good Fair Poor

a. Disassembly/Re-assembly: 1 2 3 *4 *5

b. Circuit Checks: 1 2 3 *4 *5

c. Replacement of Parts: 1 2 3 *4 *5

d. Adjustment (s): 1 2 3 *4 *5

* If (4) or (5) was circled, please be specific.

QUESTIONNAIRE

Modèle _____
Un modèle par questionnaire

Cher Monsieur,

Merci pour votre coopération à propos du service après-vente des produits PIONEER.

Ce questionnaire a pour but l'amélioration de notre service d'entretien et des manuels de nos produits. Nous vous prions d'évaluer dans ce questionnaire les éléments de nos manuels de service. Vos conseils seront précieux et pris en considération dans la réalisation de nos produits dans l'avenir. En vous remerciant d'avance, agréez, cher monsieur, l'expression de nos sentiments distingués.

PIONEER ELECTRONIC CORPORATION

T. Nakagawa, Manager, Service Section, Administration Department, International Division

1. ÉVALUATION EN FACILITÉ DE SERVICE Cerclez le numéro.
MODELE Bon, Passable, Mauvais,

a. Démontage/remontage 1 2 3 *4 *5

b. Examen de circuits 1 2 3 *4 *5

c. Rechange de pièces 1 2 3 *4 *5

d. Facilité de réglage 1 2 3 *4 *5

* Si vous cerclez No. 4 ou 5, donnez l'explication concrète.

ENCUESTA

Modelo _____
Uno modelo por encuesta

Querido señor,

Muchas gracias por su cooperación en el servicio de post-venta de los productos de Pioneer. Esto es para mejorar el servicio de post-venta de nuestros productos. Les pedimos a ustedes responder a las preguntas siguientes. Su opinión e idea estarán tenido en cuenta en los productos futuros.

Nos complacemos en saludarles muy atentamente,

PIONEER ELECTRONIC CORPORATION

T. Nakagawa, Manager, Service Section, Administration Department, International Division

1. EVALUACION EN LA FACILIDAD DE SERVICIO Marque uno entre los numeros siguientes.
MODELO Bueno Medio Malo

a. Desmante: 1 2 3 *4 *5

b. Examen de circuito: 1 2 3 *4 *5

c. Reemplazo de piezas: 1 2 3 *4 *5

d. Ajuste: 1 2 3 *4 *5

* Si marca (4) o (5), ejemplifiquelo concretamente.

CONTENTS

1. FRONT PANEL FACILITIES	3
2. SPECIFICATIONS	4
3. DISASSEMBLY	5
4. PARTS LOCATION	7
5. EXPLODED VIEW	8
6. ELECTRICAL PARTS LIST	15
7. PACKING	18
8. P.C. BOARDS CONNECTION DIAGRAM	19
9. SCHEMATIC DIAGRAM	23
10. BLOCK DIAGRAM	27
11. ADJUSTMENTS	29
RÉGLAGE	35
AJUSTE	41
12. IC DATA	47
13. SUPPLEMENT FOR KU TYPE	48
14. SUPPLEMENT FOR HEZ TYPE	50
15. SUPPLEMENT FOR HB TYPE	56

ENCUESTA

Un modelo por encuesta

e. Su consejo, opinión u idea en el servicio de este modelo.

2. EVALUACION DEL MANUAL DE SERVICIO

a. Circuito & Descripción de mecanismos.

b. Diagrama del circuito.

3. OTRAS

Describe otras partes difíciles de reparar.

Respondido por : _____ Fecha : _____

Nombre : _____ Edad : _____

Compañía : _____

Dirección : _____

Manda esta encuesta al domicilio del distribuidor, por favor.

QUESTIONNAIRE

Un modèle par questionnaire

e. Votre conseil ou avis sur le service

2. VOTRE APPRÉCIATION DU MANUEL DE SERVICE

a. Circuit et description du mécanisme.

b. Diagramme du circuit.

3. AUTRES

Anotez les autres points difficiles à réparer.

Répondu par : _____ Date : _____

Nom : _____ Âge : _____

Compagnie : _____

Adresse : _____

Adressez-vous ce questionnaire au distributeur, S.V.P.

QUESTIONNAIRE

One Model per questionnaire

e. Your advice, opinion or ideas related to servicing this product.

2. SERVICE MANUAL EVALUATION

a. Circuit & Mechanism Description

b. Circuit Diagram

3. OTHER

Please describe other areas of servicing which you may find difficult.

Completed by : _____ Date : _____

Company Name : _____

Address : _____

City/State/Zip : _____

Please send this form filled to the distributor in your country.

1. FRONT PANEL FACILITIES

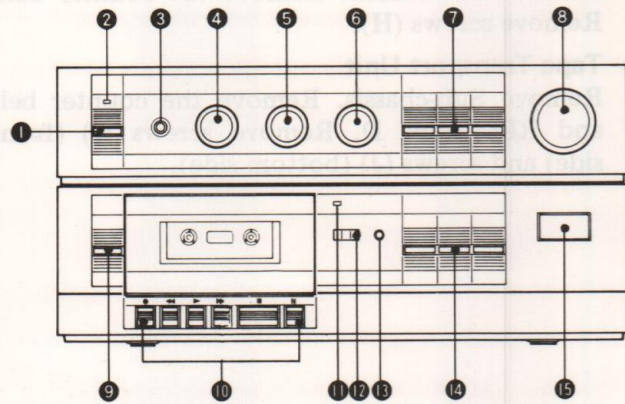

1 POWER SWITCH

2 POWER INDICATOR

3 HEADPHONES JACK

4 BASS CONTROL

5 TREBLE CONTROL

6 BALANCE CONTROL

7 FUNCTION SWITCHES

TAPE (Ⓞ) : Push when playing back tapes.
 TUNER (Ⓜ) : Push when listening to broadcast on the tuner.
 PHONO (Ⓞ) : Push when playing records on the turntable.

8 VOLUME CONTROL

9 EJECT BUTTON

Push this button to open the cassette door.

10 OPERATION SWITCHES

- (Rec) : Push this switch to start recording. When depressed to the ON position, the Rec indicator lights. The switch does not work when a cassette is not loaded or when the erasure prevention tabs of a loaded cassette have been broken off.
- ◀ (REW) : Push this switch to rewind the tape quickly.
- ▶ (Play) : Push this switch to start tape playback.
- ▶▶ (FF) : Push this switch to sent the tape forward quickly.
- (Stop) : Push this switch to stop the tape running and to release the function switches.
- ⏸ (Pause) : Push this switch to stop the tape temporarily. Release it to resume running. The tape does not stop during fast forward or rewind operations even when the ⏸ (pause) switch is pushed.

11 REC INDICATOR

This lights during the recording mode.

12 TAPE COUNTER

13 RESET BUTTON

Push this button to reset the tape counter display to 000.

14 TAPE SELECTOR

These selectors allow the tape's bias and equalization characteristics to be selected during recording and the equalization characteristics during playback, in line with the type of tape being used.

- METAL : Push when using the METAL tape.
- CrO₂ : Push when using the CrO₂ tape.
- NORMAL : Push when using the NORMAL tape.

15 *DOLBY NR SWITCH

Push this switch to ON when recording with the built-in Dolby noise reduction system and when playing back tapes which have been recorded using the system.

~~~~~  
 \*Noise Reduction manufactured under license from Dolby Laboratories Licensing Corporation.  
 "Dolby" and the double-D symbol are trademarks of Dolby Laboratories Licensing Corporation.  
 ~~~~~

2. SPECIFICATIONS

AMPLIFIER SECTION

Continuous Average Power Output is 25 watts* per channel, min., at 8 ohms from 40 Hertz to 20,000 Hertz with no more than 0.3% total harmonic distortion.

*Measured pursuant to the federal Trade Commission's Trade Regulation rule on Power Output Claims for Amplifier.

Continuous Power Output	
40 to 20,000Hz	25W + 25W (T.H.D. 0.3% 8Ω)
1kHz (DIN)	32W + 32W (T.H.D. 1%, 8Ω)
Hum and Noise (IHF, short-circuited, A network)	
PHONO	72dB
Hum and Noise (DIN continuous Power/50mV)	
PHONO	68dB/60dB
Total Harmonic Distortion (40Hz to 20,000Hz, 8 ohms, from TUNER)	
Continuous rated power output	No more than 0.3%
12.5 watts per channel power output	No more than 0.2%

Tape Deck Section

Systems	4 track, 2-channel stereo
Heads	"Hard Permalloy" recording/playback head x 1 "Ferrite" erasing head x 1
Motor	DC servo motor x 1
Wow and Flutter	No more than 0.06% (WRMS) No more than ±0.18% (DIN)
Fast Winding Time	Approximately 110 seconds (C-60 tape)
Frequency Response	
-20dB recording:	
Normal tape	35 to 13,000Hz
Chrome tape	35 to 14,000Hz
Metal tape	35 to 15,000Hz
Signal-to-Noise Ratio	
Dolby NR OFF	More than 57dB
Noise Reduction Effect	
Dolby NR ON	More than 10dB (at 5kHz)
Harmonic Distortion	No more than 1.5% (0dB)

Furnished Parts

Operating instructions	1
------------------------	---

Miscellaneous

Power requirements	
KU and KC models	AC120V, 60Hz
HE model	AC220V, 50/60Hz
HB and HP models	AC240V, 50/60Hz
S and S/G models	AC110V/120V/220V/240V, 50/60Hz (switchable)

Power Consumption

KU model	72W
KC model	132W
HE, HB and HP models	170W
S and S/G models	62W
Dimensions	420 (W) x 210 (H) x 248 (D)mm
Weight (without package)	6.9kg

NOTE:
 Specifications and design subject to possible modification without notice, due to improvements.

3. DISASSEMBLY

- **Bonnet Case**
Remove screws (A) (top side), screw (B) (rear side) and screws (C) (left and right side).
- **Bottom Plate**
Remove screws (D) (bottom side).

- **Sub-chassis (Power Assembly, Power Switch Assembly)**
Disconnect C1 (ceramic capacitor). Remove POWER knob. Remove screws (E) (rear side) and screws (F) (upper side).

- **Control Assembly**
Pull off the knobs (VOLUME, BALANCE, TREBLE and BASS). Remove nuts (G) (control shafts).

- **Tape Counter**
Remove Sub-chassis. Remove the counter belt. Remove screws (H).
- **Tape Transport Unit**
Remove Sub-chassis. Remove the counter belt and REC joint D. Remove screws (I) (front side) and screws (J) (bottom side).

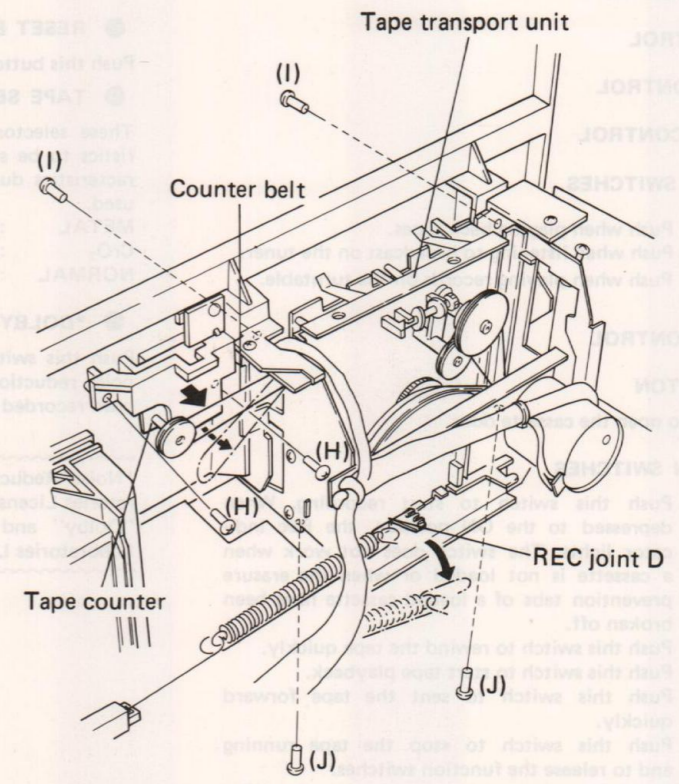
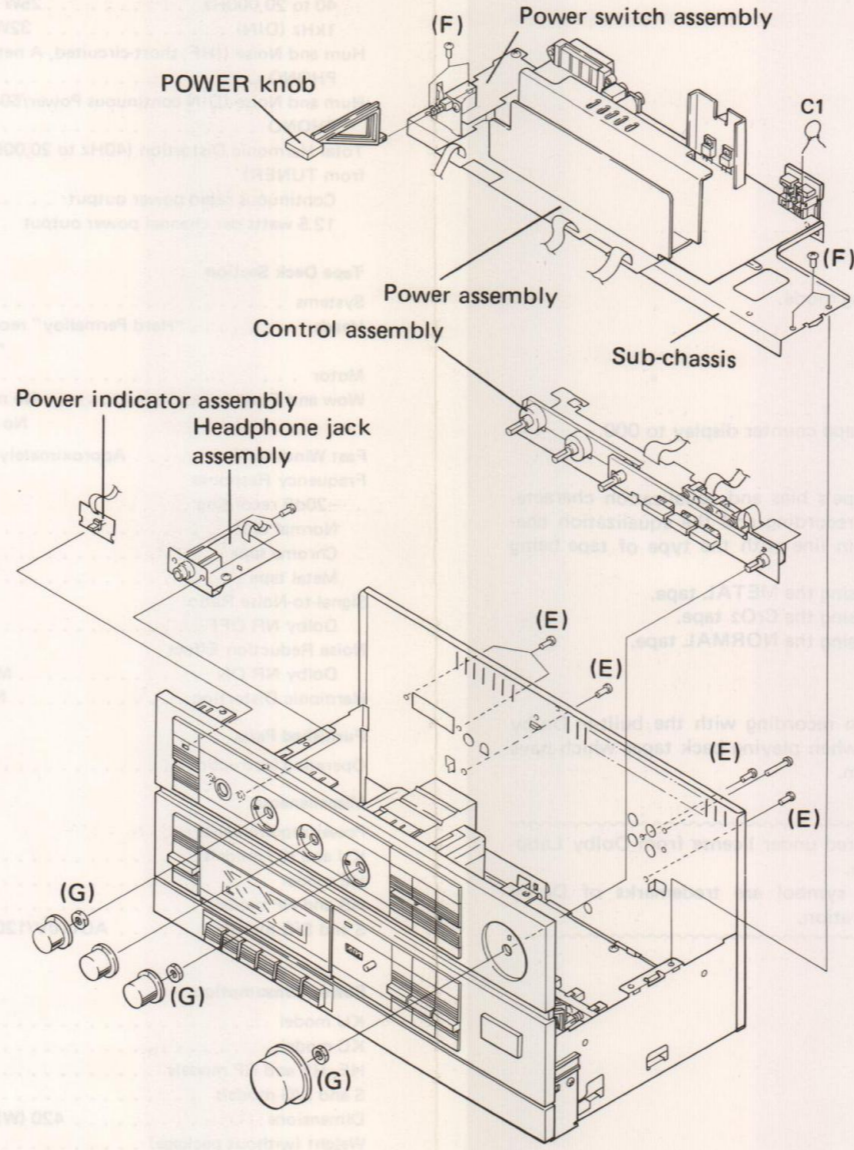
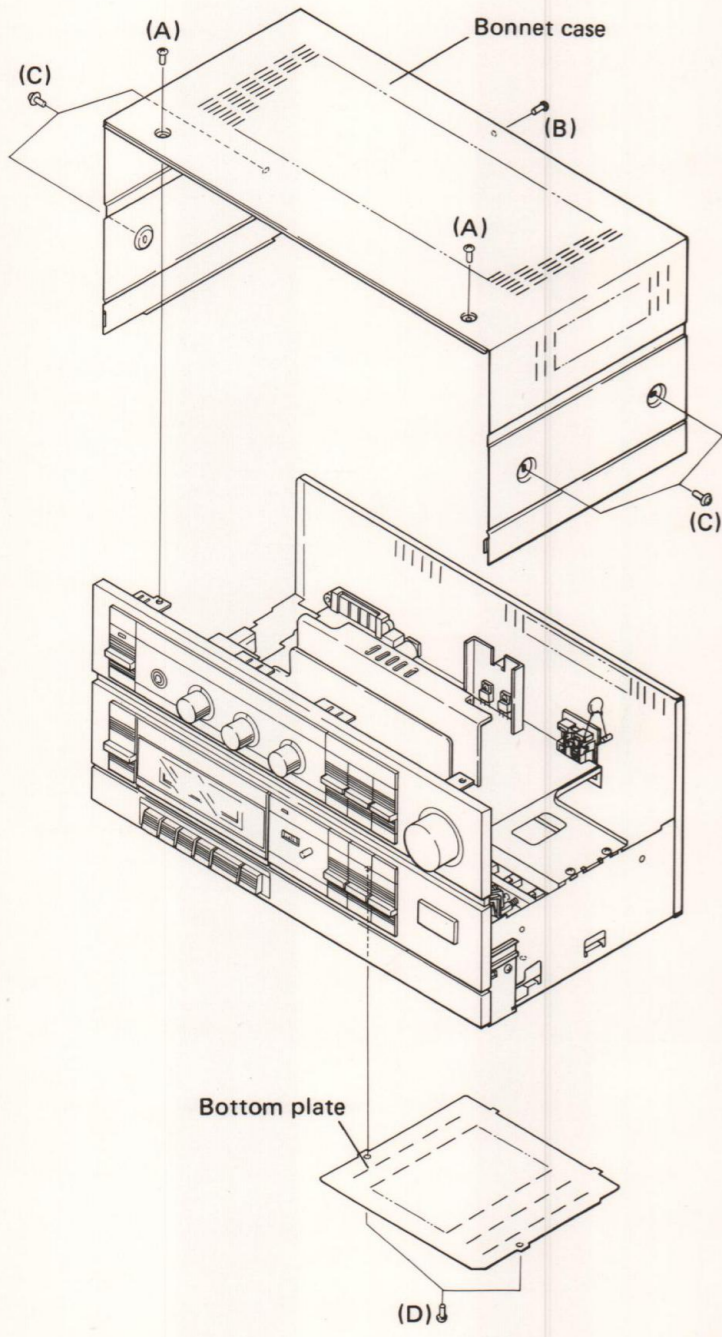

4. PARTS LOCATION

- Parts without part number cannot be supplied.
- The Δ mark found on some component parts indicates the importance of the safety factor of the part. Therefore, when replacing, be sure to use parts of identical designation.
- For your Parts Stock Control, the fast moving items are indicated with the marks **★★** and **★**.
★★ GENERALLY MOVES FASTER THAN ★.
 This classification shall be adjusted by each distributor because it depends on model number, temperature, humidity, etc.

Front Panel View

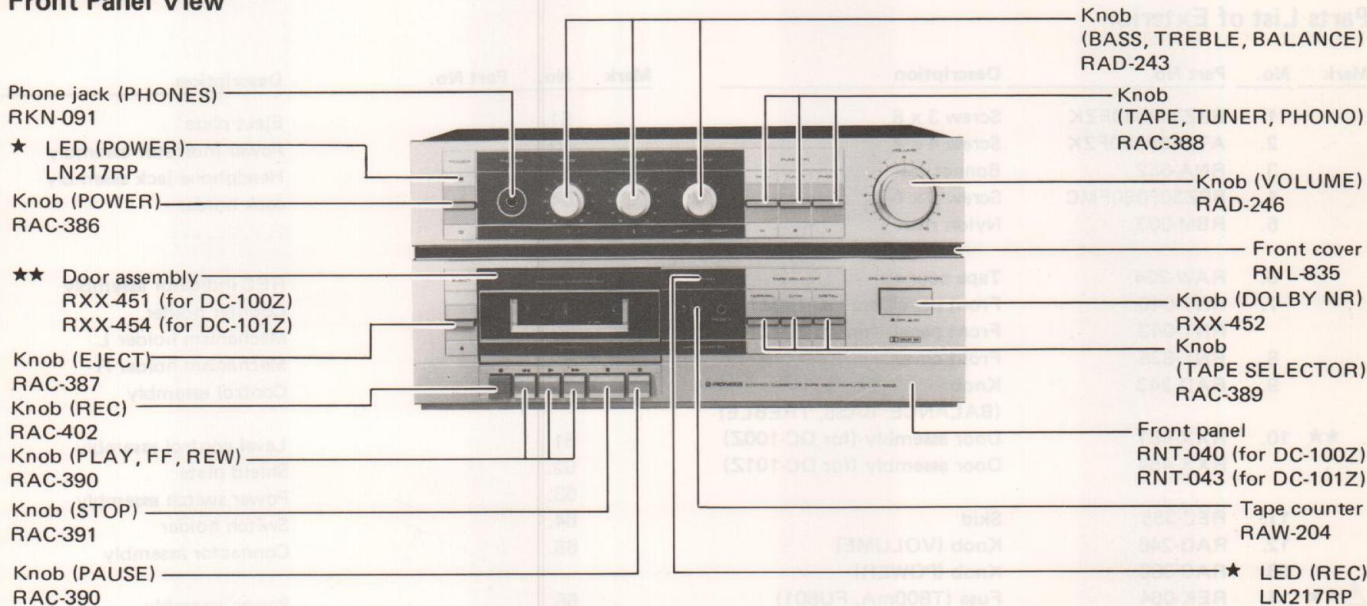

Rear Panel View

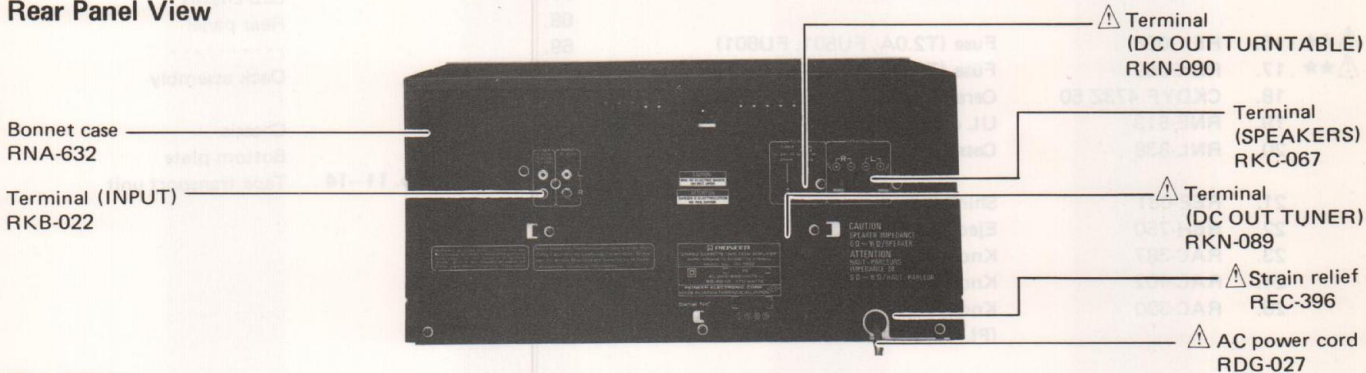

Top View

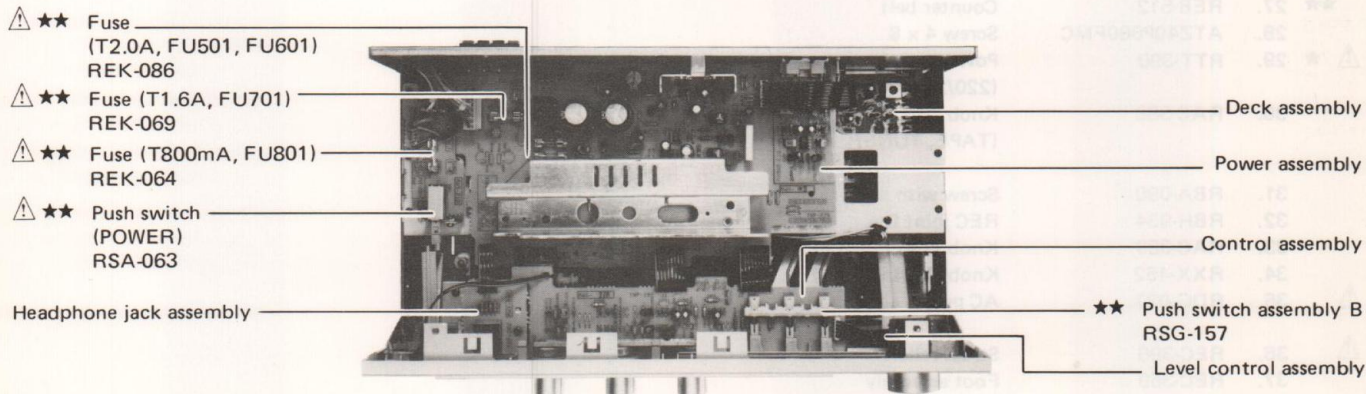

5. EXPLODED VIEW

Exterior

- Parts without part number cannot be supplied.
- The **△** mark found on some component parts indicates the importance of the safety factor of the part. Therefore, when replacing, be sure to use parts of identical designation.
- For your Parts Stock Control, the fast moving items are indicated with the marks **★★** and **★**.
★★ GENERALLY MOVES FASTER THAN ★.
This classification shall be adjusted by each distributor because it depends on model number, temperature, humidity, etc.

Parts List of Exterior

Mark	No.	Part No.	Description	Mark	No.	Part No.	Description
	1.	BBZ30P080FZK	Screw 3 x 8		51.		Eject plate
	2.	ATZ40P080FZK	Screw 4 x 8		52.		Power indicator assembly
	3.	RNA-632	Bonnet case		53.		Headphone jack assembly
	4.	BBZ30P060FMC	Screw 3 x 6		54.		Jack holder
	5.	RBM-003	Nylon rivet		55.	
	6.	RAW-204	Tape counter		56.		REC indicator assembly
	7.	RNT-040	Front panel (for DC-100Z)		57.		Counter holder
		RNT-043	Front panel (for DC-101Z)		58.		Mechanism holder L
	8.	RNL-835	Front cover		59.		Mechanism holder R
	9.	RAD-243	Knob (BALANCE BASS, TREBLE)		60.		Control assembly
★★	10.	RXX-451	Door assembly (for DC-100Z)		61.		Level control assembly
		RXX-454	Door assembly (for DC-101Z)		62.		Shield plate
	11.	REC-355	Skid		63.		Power switch assembly
	12.	RAD-246	Knob (VOLUME)		64.		Switch holder
	13.	RAC-386	Knob (POWER)		65.		Connector assembly
△★★	14.	REK-064	Fuse (T800mA, FU801)		66.		Power assembly
	15.	PMA30P060FMC	Screw 3 x 6		67.		Sub-chassis
△★★	16.	REK-086	Fuse (T2.0A, FU501, FU601)		68.		Rear panel
△★★	17.	REK-069	Fuse (T1.6A, FU701)		69.	
	18.	CKDYF 473Z 50	Ceramic capacitor (C1)		70.		Deck assembly
	19.	RNE-513	UL cord clamper		71.		Chassis
	20.	RNL-838	Cassette plate		72.		Bottom plate
	21.	REE-081	Shining paper		73.	Refer to pp. 11-14	Tape transport unit
	22.	RBH-750	Eject spring				
	23.	RAC-387	Knob (EJECT)				
	24.	RAC-402	Knob (REC)				
	25.	RAC-390	Knob (PLAY, FF, REW, PAUSE)				
	26.	RAC-391	Knob (STOP)				
★★	27.	REB-512	Counter belt				
	28.	ATZ40P080FMC	Screw 4 x 8				
△★	29.	RTT-390	Power transformer (220/240V)				
	30.	RAC-388	Knob (TAPE, TUNER, PHONO)				
	31.	RBA-090	Screw with bar				
	32.	RBH-934	REC joint D				
	33.	RAC-389	Knob (TAPE SELECTOR)				
	34.	RXX-452	Knob (DOLBY NR)				
△	35.	RDG-027	AC power cord				
△	36.	REC-396	Strain relief				
	37.	REC-369	Foot assembly				
		REC-371	Cord binder				

Exterior

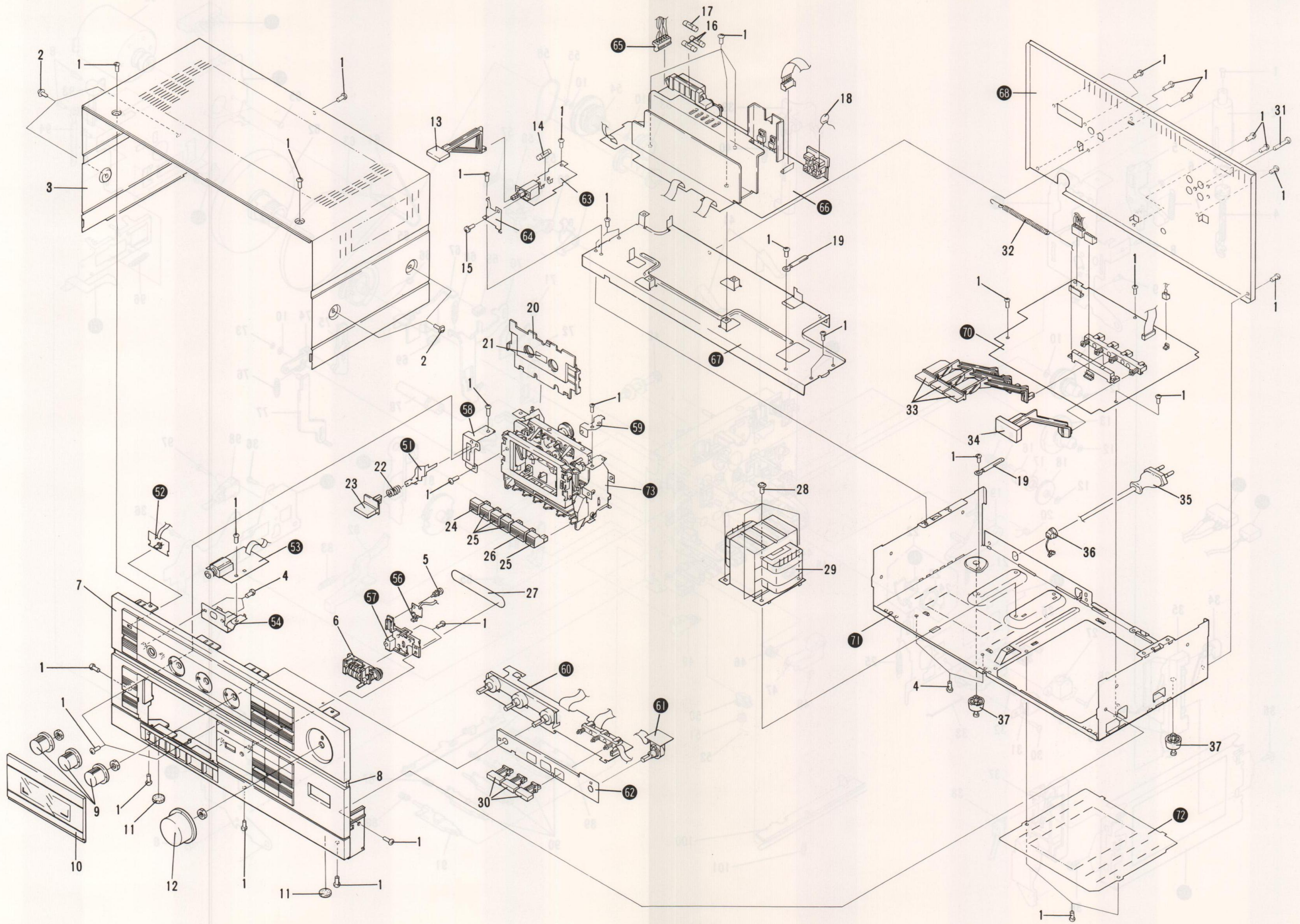

Tape Transport Unit

A

B

C

D

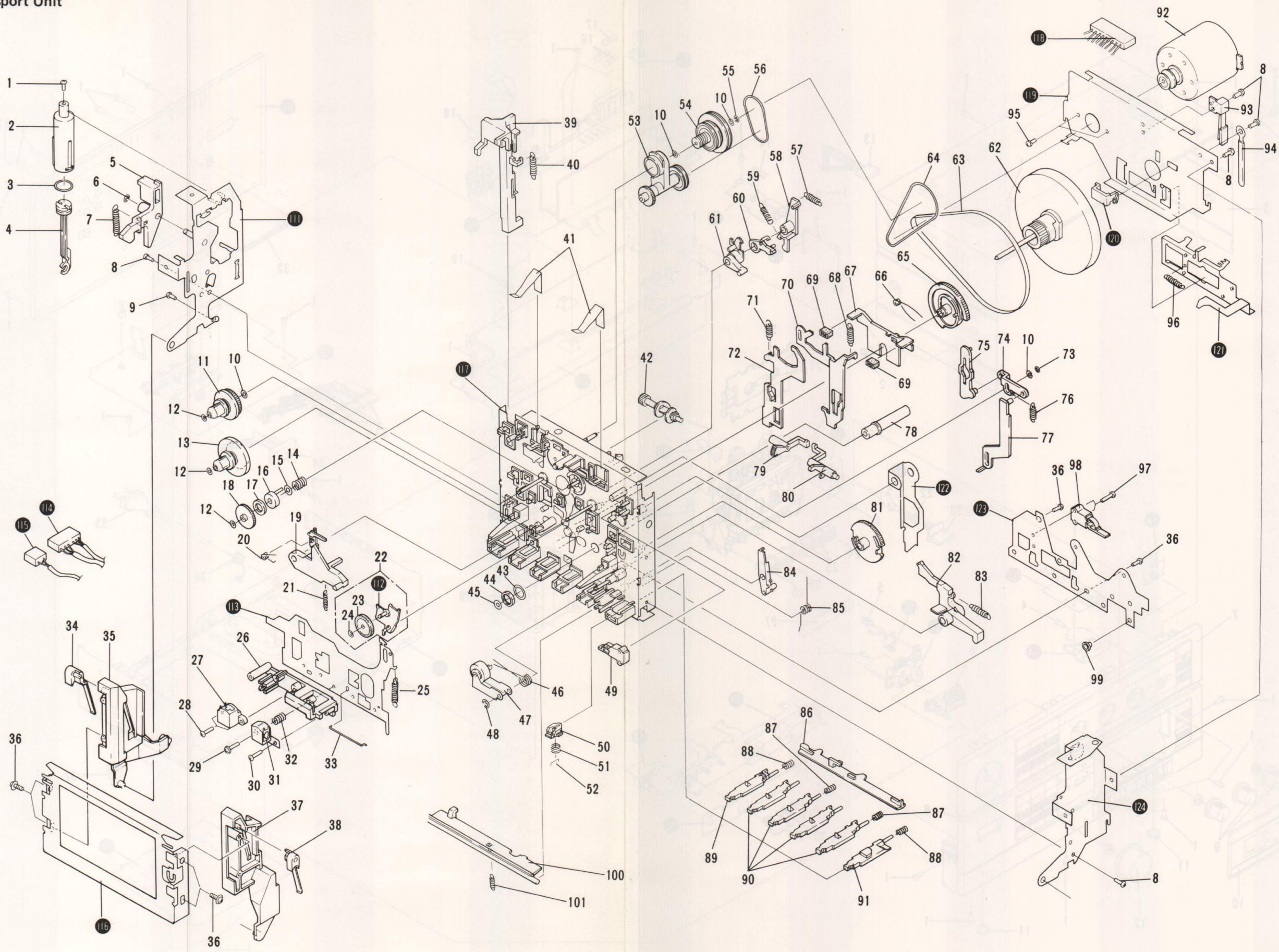

NOTES:

- Parts without part number cannot be supplied.
- The Δ mark found on some component parts indicates the importance of the safety factor of the part. Therefore, when replacing, be sure to use parts of identical designation.
- For your Parts Stock Control, the fast moving items are indicated with the marks **★★** and **★**.
★★ GENERALLY MOVES FASTER THAN ★.
This classification shall be adjusted by each distributor because it depends on model number, temperature, humidity, etc.

Parts List of Tape Transport Unit

Mark	No.	Part No.	Description	Mark	No.	Part No.	Description
					41.	RBK-166	Half set spring
					42.	RNL-322	Cam gear
					43.	RBE-021	Washer
					44.	NK90FCr	Nut
					45.	RBK-030	Oil stopper
					46.	RBH-890	Pinch pressure spring
				★★	47.	RXB-495	Pinch arm assembly
					48.	YE20FUC	Washer E-type
				★★	49.	RSN-034	Lever switch (S1)
					50.	RNL-334	Ratchet holder
					51.	RBH-888	Ratchet spring
					52.	RBH-870	Ratchet pin
					53.	RXB-577	Drive arm full assembly
					54.	RXB-976	Drive pulley assembly
					55.	YE15FUC	Washer E-type
★★	11.	RXB-377	Supply reel base assembly	★★	56.	REB-455	Drive belt B
	12.	RBK-057	Washer		57.	RBH-876	Gear lever spring A
★★	13.	RXB-360	TU reel base assembly		58.	RNL-297	Gear lever A
	14.	RBH-885	Detector spring		59.	RBH-877	Gear lever spring B
	15.	RBK-071	Washer		60.	RNL-282	Gear lever B
	16.	RNL-318	Detector disk		61.	RNL-296	Gear lever C
	17.	RED-194	Detector felt		62.	RXB-576	Flywheel assembly
	18.	RNK-998	Idler gear	★★	63.	REB-453	Capstan belt
	19.	RNL-298	Action lever	★★	64.	REB-454	Drive belt A
	20.	RBH-873	Idler pressure spring		65.	RNL-288	Cam gear
	21.	RBH-875	Action lever spring		66.	RBH-879	Trigger spring
	22.	RXB-579	Idler arm full assembly		67.	RNL-280	Brake plate
★★	23.	RNL-337	TU idler		68.	RBH-884	Action plate spring
	24.	WA17D040D025	Washer		69.	REB-466	Brake shoe
	25.	RBH-874	HB return spring		70.	RNL-811	FF action plate
	26.	RNL-050	Sub-head base		71.	RBH-916	Action plate spring L
★	27.	RPB-085	Erase head		72.	RNL-810	REW action plate
	28.	PMZ20P130FMC	Screw 2 x 13		73.	YS20FBT	Washer C-type
	29.	iMZ20Y120FMC	Screw 2 x 12		74.	RNL-275	Link
	30.	PMZ20P120FMC	Screw 2 x 12		75.	RNL-274	Detector lever
★★	31.	RPB-118	REC/PB head		76.	RBH-886	Link return spring
	32.	RBH-723	Head adjust spring		77.	RNL-289	Stop lever
	33.	RBH-782	HB drive spring		78.	RXB-670	Metal holder A assembly
	34.	RNL-057	Pocket spring L		79.	RNL-812	Joint L
	35.	RNL-439	Pocket L		80.	RNL-276	Joint R
	36.	BBZ26P080FZK	Screw 2.6 x 8				
	37.	RNL-440	Pocket R				
	38.	RNL-058	Pocket spring R				
	39.	RNL-284	REC detector arm				
	40.	RBH-883	Detector arm spring				

Mark	No.	Part No.	Description	Mark	No.	Part No.	Description
	81.	RNL-831	Cam gear R		111.		Side plate L assembly B
	82.	RNL-295	Pause lever		112.		Idler arm assembly
	83.	RBH-880	Pause lever spring		113.		Head base
	84.	RNL-281	Gear lever R		114.		Connector assembly 6-P
	85.	RBH-881	Trigger spring R		115.		Connector assembly 2-P
	86.	RNL-486	REC connection arm		116.		Pocket frame B
	87.	RBH-889	Button return spring		117.		Chassis assembly
	88.	RBH-909	Pause button spring		118.		Connector socket 9-P
	89.	RNL-487	REC button		119.		Flywheel receptacle
	90.	RNL-287	Function button		120.		Thrust receptacle
	91.	RNL-279	Pause button		121.		REC action plate
★★	92.	RXM-088	Motor with pulley		122.		REC action lever
★★	93.	RSN-025	Spring switch (S3)		123.		Plate
	94.	RNE-605	UL cord clamper D		124.		Side plate R
	95.	PMA26P040FMC	Screw 2.6 x 4		125.	
	96.	RBH-882	REC return spring				
	97.	PMZ20P080FMC	Screw 2 x 8				
★★	98.	RSN-033	Lever switch (S2)				
	99.	RLB-469	Collar				
	100.	RNL-303	Lock plate				
	101.	RBH-922	Lock plate spring				
		REC-371	Cord binder				

6. ELECTRICAL PARTS LIST

NOTES:

- When ordering resistors, first convert resistance values into code form as shown in the following examples.
 - Ex. 1 When there are 2 effective digits (any digit apart from 0), such as 560 ohm and 47k ohm (tolerance is shown by J = 5%, and K = 10%).
 - 560Ω 56 x 10¹ 561 RD¼PS 561J
 - 47kΩ 47 x 10³ 473 RD¼PS 473J
 - 0.5Ω 0R5 RN2H 05K
 - 1Ω 010 RS1P 01K
 - Ex. 2 When there are 3 effective digits (such as in high precision metal film resistors).
 - 5.62kΩ 562 x 10¹ 5621 RN¼SR 5621F
- The Δ mark found on some component parts indicates the importance of the safety factor of the part. Therefore, when replacing, be sure to use parts of identical designation.
- For your Parts Stock Control, the fast moving items are indicated with the marks **★★** and **★**.
★★ GENERALLY MOVES FASTER THAN **★**.
 This classification shall be adjusted by each distributor because it depends on model number, temperature, humidity, etc.

Miscellaneous Parts

FUSES

Mark	Symbol & Description	Part No.
Δ ★★	FU601, FU601 Fuse (T2A)	REK-086
Δ ★★	FU701 Fuse (T1.6A)	REK-069
Δ ★★	FU801 Fuse (T800mA)	REK-064

P.C. BOARD ASSEMBLIES

Mark	Symbol & Description	Part No.
	Deck assembly	Non supply
	REC indicator assembly	Non supply
	Power assembly	Non supply
	Control assembly	Non supply
	Level control assembly	Non supply
	Headphone jack assembly	Non supply
	Power switch assembly	Non supply
	Power indicator assembly	Non supply

SWITCHES (on the tape transport unit)

Mark	Symbol & Description	Part No.
★★	S1 Lever switch (PLAY)	RSN-034
★★	S2 Lever switch (FF)	RSN-033
★★	S3 Spring switch (REC)	RSN-025

OTHERS

Mark	Symbol & Description	Part No.
Δ ★	T1 Power transformer (220/240V)	RTT-390
Δ	AC power cord	RDG-027
★★	Motor with pulley	RXM-088
★★	REC/PB head	RPB-118
★	Erase head	RPB-085
C1	Ceramic capacitor	CKDYF 473Z 50

Deck Assembly

SEMICONDUCTORS

Mark	Symbol & Description	Part No.
★★	Q307	HA12045
★★	Q101, Q102, Q201, Q202	2SC2240
★★	Q103—Q107, Q203—Q207, Q304, Q305	2SC1740LN
★★	Q303	2SC1741
★★	Q301, Q302	2SC1740LN-S
★★	Q306	2SA933LN
★★	Q308	M5218L
★	D312	RD5.1EB2 (MTZ5.1B)
★	D301—D308, D310, D311, D313	1S2473
★	D101, D201	1K60AUF

COILS, FILTERS

Mark	Symbol & Description	Part No.
	L301 Oscillator coil	RTD-032
	L302 Line coil	RTF-101
	L101, L201 MPX filter	RTF-138
	L102, L202 Peaking coil	RTF-629
	L103, L203 Trap coil	RTF-152

SWITCHES

Mark	Symbol & Description	Part No.
★★	S301—S304 Push switch assembly (S301—S303: TAPE SELECTOR, S304: DOLBY NR)	RSG-158
★★	S305 Slide switch (Recording/playback)	RSH-048

CAPACITORS

Mark	Symbol & Description	Part No.
	C122, C222	CEA R27M 50
	C129, C229	CEA R33M 50
	C123, C223	CEA R82M 50
	C118, C125, C126, C130, C218, C225, C226, C230, C310	CEA 010M 50
	C114, C124	CEA 2R2M 50
	C106, C107, C110, C117, C128, C206, C207, C210, C217, C228	CEA 100M 16
	C313, C314	CEA 220M 16
	C302	CEA 4R7M 50
	C109, C209, C302, C315, C321	CEA 470M 16
	C103, C203, C113, C213, C303, C319	CEA 101M 16
	C116, C301, C311, C312	CEA 101M 16
	C317, C318, C322	CEA 221M 16
	C304	CEA 221M 10
	C121, C221	CEANL 4R7M 50
	C102, C112, C115, C202, C212, C215	CEANL 100M 16
	C307, C308	CQMA 322K 50
	C309	CQMA 682K 50
	C120, C220	CQMA 472J 50
	C133, C233	CQMA 562J 50
	C132, C232	CQMA 682J 50
	C131, C231	CQMA 822J 50
	C105, C205	CQMA 103J 50
	C108, C208, C306	CQMA 153J 50
	C124, C224	CQMA 183J 50
	C119, C219	CQMA 333J 50
	C305	CQPA 562J 100
	C104, C204	CCPSL 220J 50
	C134, C234	CCDSL 471K 50
	C127, C227	CCDSL 271J 50
	C135, C235	CCDSL 101K 50

Mark	Symbol & Description	Part No.
	C111, C211	CCDSL 271J 50
	C316	CKDYF 473Z 50
	C101, C201	CQSA 471J 50

RESISTORS

Note: When ordering resistors, convert the resistance value into code form, and then rewrite the part no. as before.

Mark	Symbol & Description	Part No.
★	V101, V102, V201, V202 Semifixed (22k-B)	RCP-223
★	V103, V203 Semifixed (150k-B)	RCP-228
	R101, R201	RD¼PM 753JNL
	R102—R109, R113, R115—R117, R119, R120, R122, R202—R209, R213, R215—R217, R219, R220, R222, R314	RD¼PM □□□J
	Other resistors	RD1/6PM □□□J

OTHERS

Mark	Symbol & Description	Part No.
	Shield case	RNH-209

RED Indicator Assembly

LED

Mark	Symbol & Description	Part No.
★	D401 (REC)	LN217RP

Power Assembly

SEMICONDUCTORS

Mark	Symbol & Description	Part No.
Δ ★★	Q705	STK4141-2S
★★	Q706	NJM4558DX
★★	Q703	2SC1740LN
★★	Q704	2SA933LN
Δ ★★	Q701, Q702	2SD1276
Δ ★	D701	RB-402LF-F
Δ ★	D702	RB-152LF-F
Δ ★	D705 (Triac)	BCR6AM-8L
Δ ★	D703, D704	10E2FD
Δ ★	D712	RD13FB3
Δ ★	D713	MTZ15A (RD15EB1)
Δ ★	D710	MTZ13B (MTZ13C) (RD13EB2) (RD13EB3)
Δ ★	D711	1SR35-100A

COILS

Mark	Symbol & Description	Part No.
	L501, L601 AF choke coil	RTH-003

CAPACITORS

Mark	Symbol & Description	Part No.
	C715, C716 Electrolytic (3300/42)	RCH-060 (RCH-062)
	C722	CEA 102M 35
	C713	CEA 471M 6R3
	C710	CEA 221M 35
	C708, C709	CEA 4R7M 50
	C707	CEA 101M 50
	C725	CEA 101M 35
	C514, C614, C731	CEA 101M 25
	C704, C705, C726	CEA 470M 25
	C723	CEA 470M 16
	C605, C605	CEA 470M 10
	C724, C727	CEA 100M 16
	C706	CEA 100M 50
	C721	CEA 2R2M 50
	C508, C608	CEA 010M 50
	C502, C602	CEANL 2R2M 50
	C506, C606	CQMA 242J 50
	C507, C607	CQMA 822J 50
Δ	C719, C720	CQMA 103K 250
	C504, C604	CCPSL 101J 50
	C503, C603	CKPYB 221K 50
	C701, C702, C714	CKDYF 223Z 50
	C512, C612	CKDYX 473M 25

RESISTORS

Note: When ordering resistors, convert the resistance value into code form, and then rewrite the part no. as before.

Mark	Symbol & Description	Part No.
Δ	R721 Wire wound (0.22/2W x 2)	RCN-051
Δ	R509, R511, R609, R611, R704—R706	RD¼LF □□□J
Δ	R722, R727, R729	RD¼PMF □□□J
Δ	R725, R728 (Fusing)	RFA¼L □□□J
	R512, R513, R516, R517, R612, R613, R616, R617, R701—R703, R707, R711, R712, R717—R720, R723, R724, R730, R731	RD¼PM □□□J
	Other resistors	RD1/6PM □□□J

OTHERS

Mark	Symbol & Description	Part No.
Δ	Terminal (DC OUT TURNTABLE)	RKN-090
Δ	Terminal (DC OUT TUNER)	RKN-089
	Terminal (SPEAKERS)	RKC-067
	Terminal (INPUT)	RKB-022
	Screw	RBA-089
	Heat proof rivet	RBM-013

Control Assembly

SWITCHES

Mark	Symbol & Description	Part No.
★★	S1101—S1103 Push switch assembly B (FUNCTION)	RSG-157

CAPACITORS

Mark	Symbol & Description	Part No.
	C905, C1005	CEA 010M 50
	C902, C1002	CEA 100M 50
	C904, C1004	CEA 220M 25
	C907, C1007	CQMA 122K 50
	C908, C1008	CQMA 562K 50
	C909, C1009	CQMA 333K 50
	C910, C1010	CQMA 124K 50
	C906, C1006	CCPSL 270J 50
	C901, C903, C1001, C1003	CCPSL 101J 50

RESISTORS

Note: When ordering resistors, convert the resistance value into code form, and then rewrite the part no. as before.

Mark	Symbol & Description	Part No.
★	VR1101—VR1103 Variable resistor assembly (BASS, TREBLE, BALANCE)	RCV-116
	R901, R914, R1001, R1014	RD¼PM □□□J
	Other resistors	RD1/6PM □□□J

Level Control Assembly

Mark	Symbol & Description	Part No.
★	VR1201 Variable resistor (VOLUME)	RCV-117

Headphone Jack Assembly

Mark	Symbol & Description	Part No.
	R1301, R1401	RD¼PM 151J
	R1302, R1402	RD¼PM 181J
	Phone jack (PHONES)	RKN-091

Power Switch Assembly

Mark	Symbol & Description	Part No.
Δ	S801 Push switch (POWER)	RSA-063
Δ	C801 Ceramic capacitor (0.01/AC250V)	RCG-009

7. PACKING

Mark	No.	Part No.	Description
	1.	RHA-261	Side pad
	2.	RRE-064	Operating instructions
	3.	RHG-736	Packing case (DC-100Z/HE)

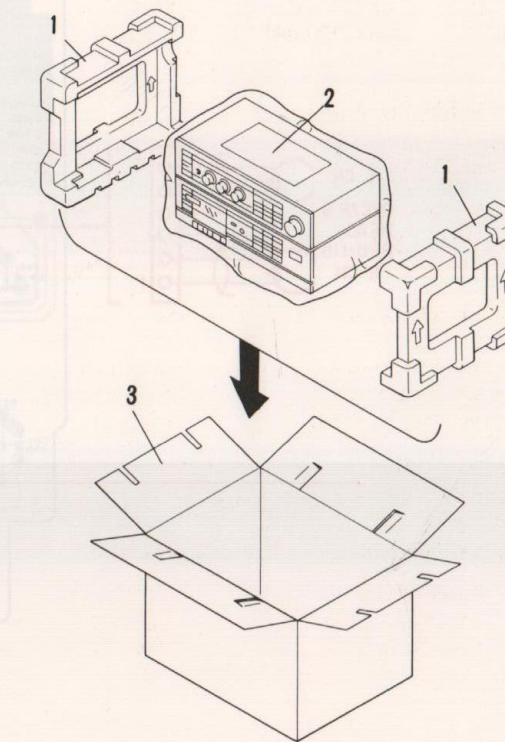

8. P.C.BOARDS CONNECTION DIAGRAM

DECK ASSEMBLY

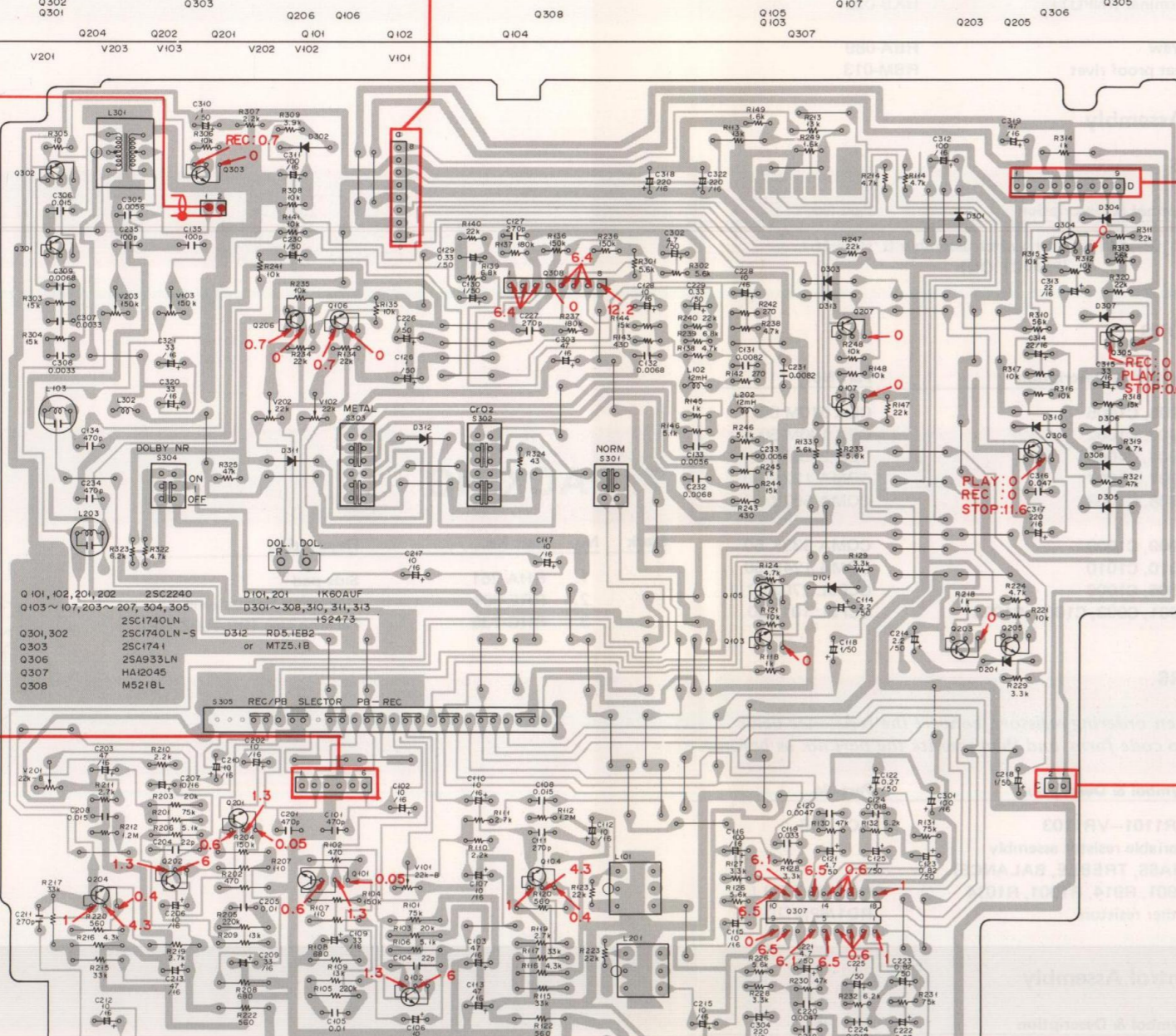

POWER ASSEMBLY

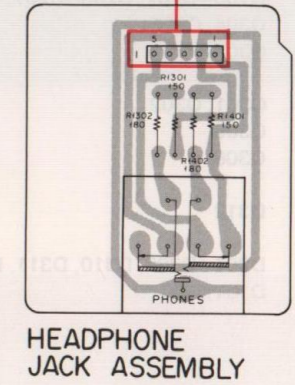
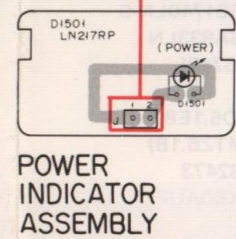
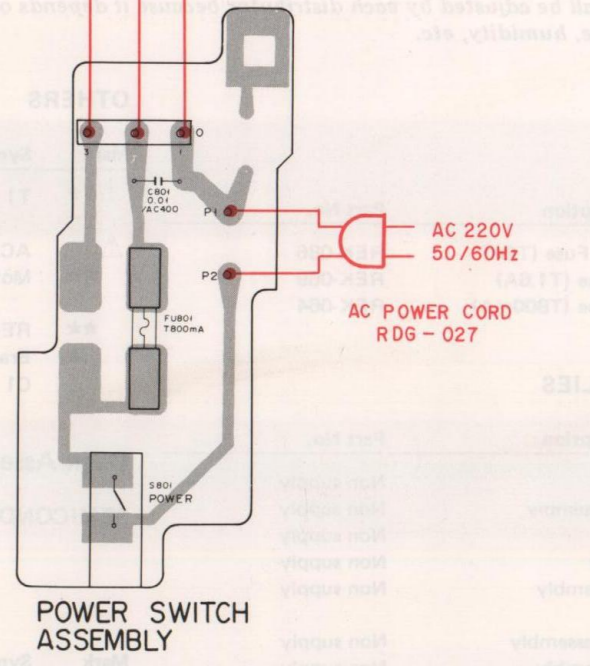
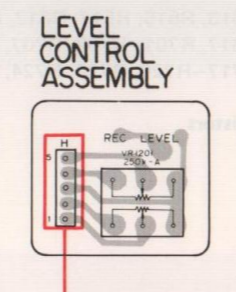
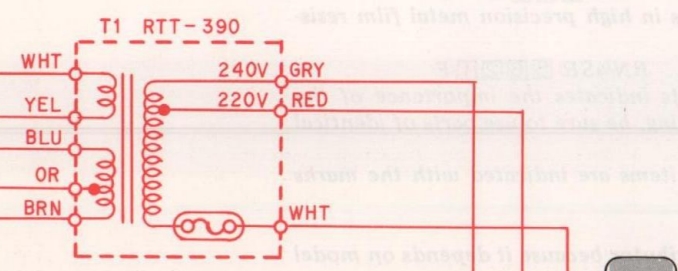
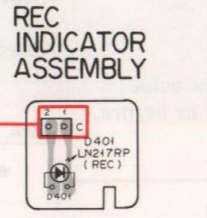
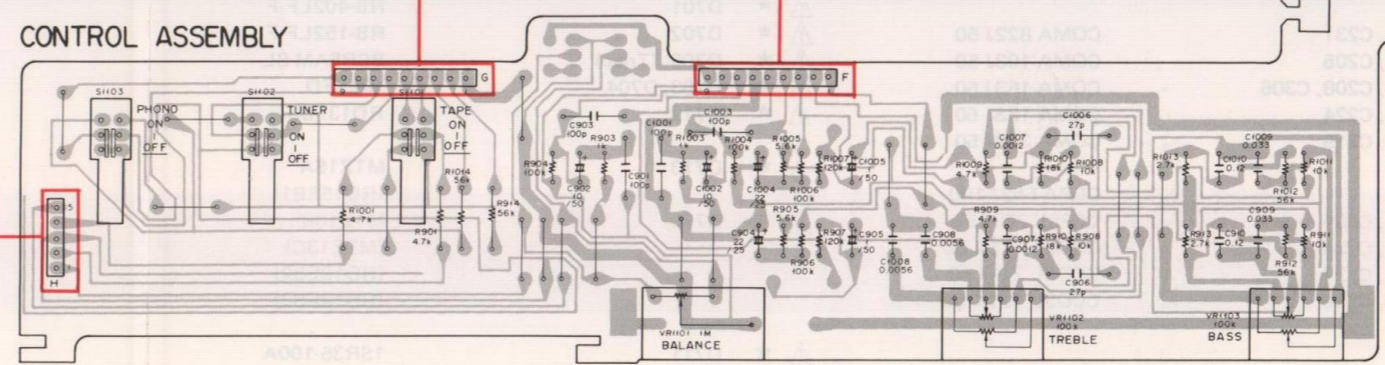
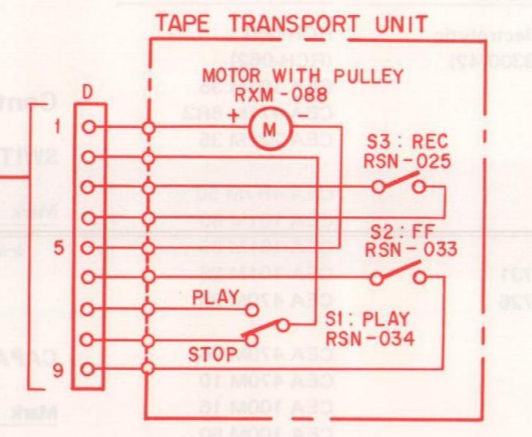
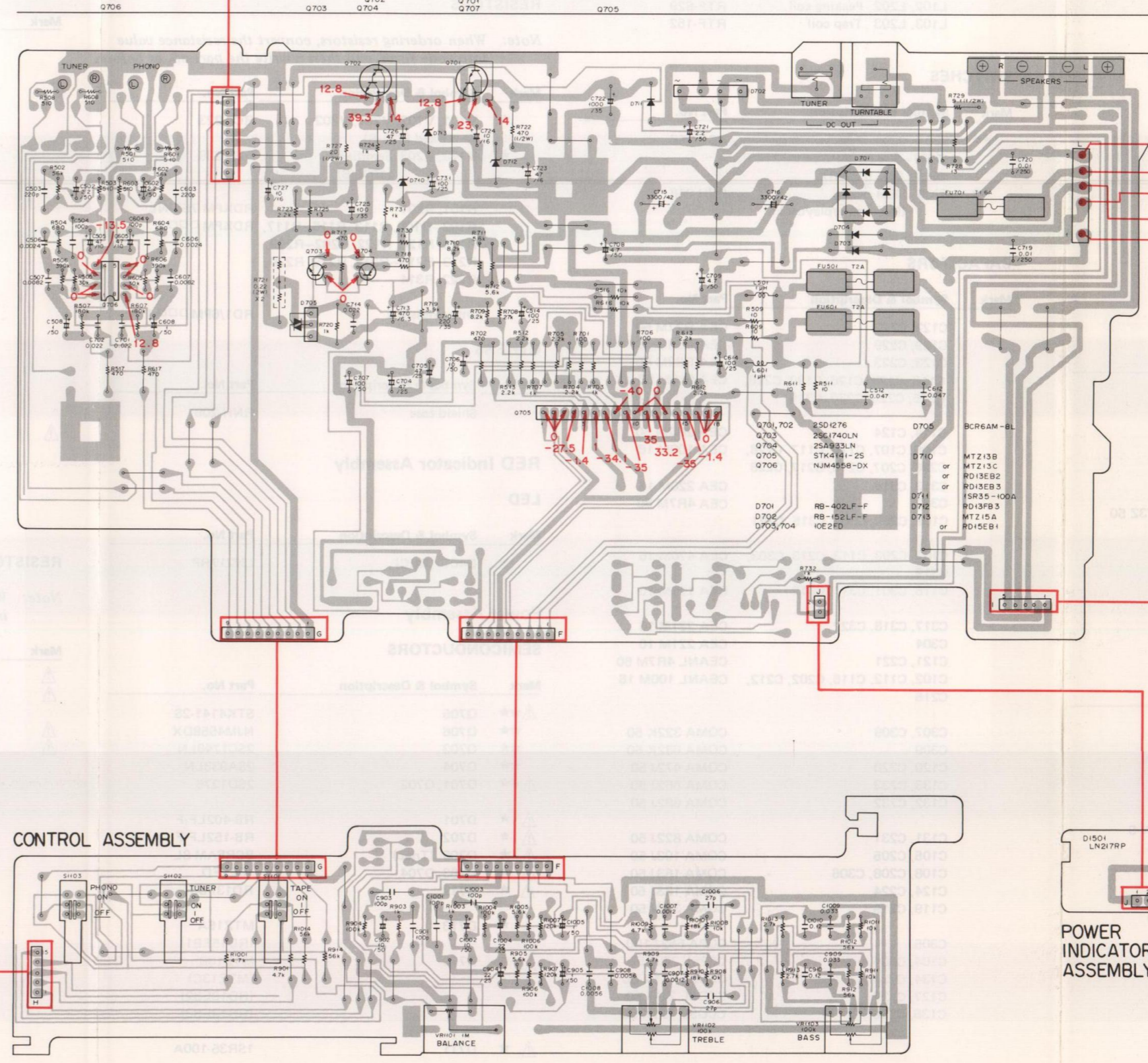

A

B

C

D

A

B

C

D

9. SCHEMATIC DIAGRAM

NOTE:
 The indicated semiconductors are representative ones only.
 Other alternative semiconductors may be used and are listed in the parts list.

A

A

B

B

C

C

D

D

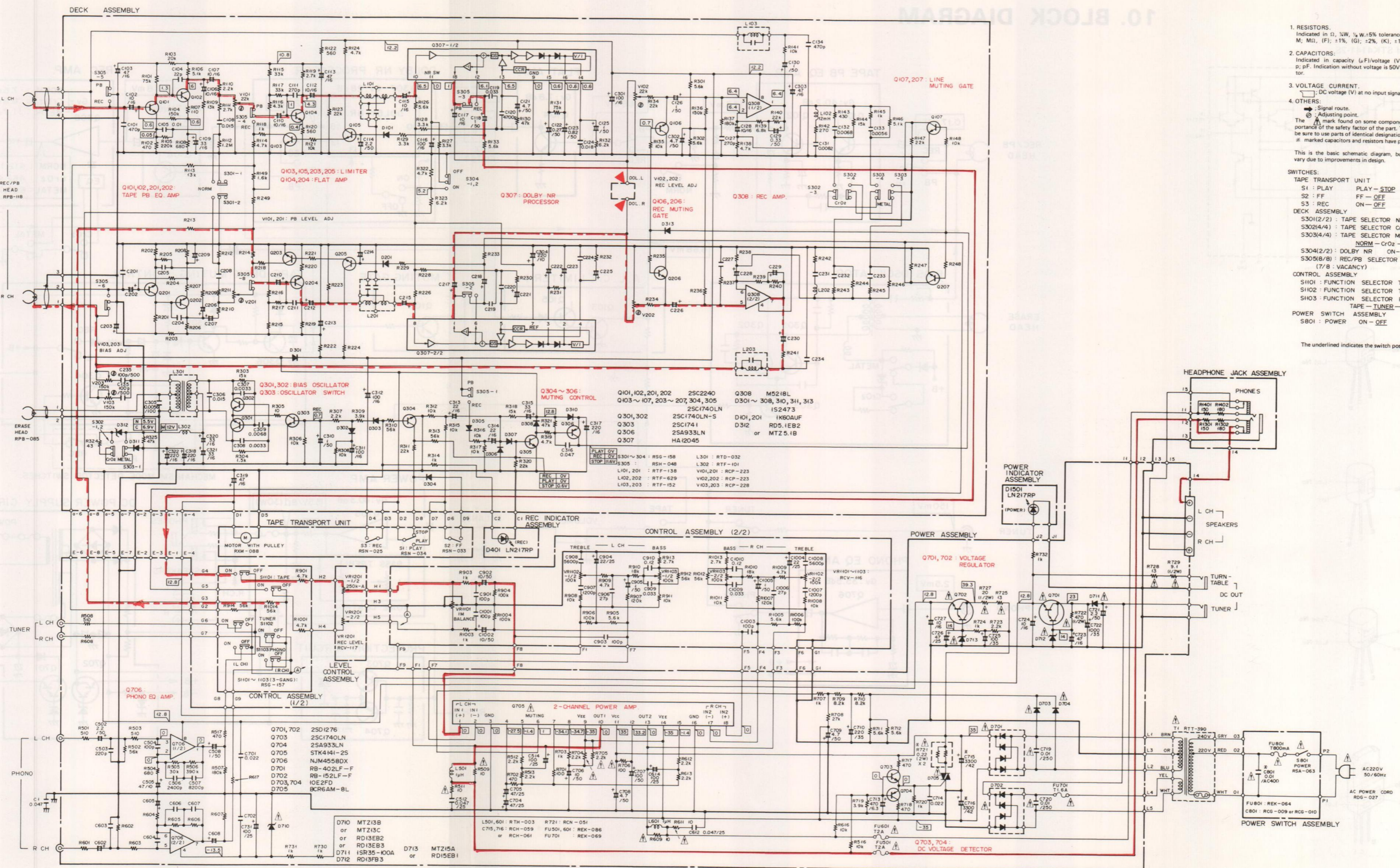

- RESISTORS:** Indicated in Ω, kΩ, MΩ, GΩ, TΩ, PΩ, FΩ, GΩ, KΩ, MΩ, TΩ tolerance unless otherwise noted; k, M, G, T, P, F, G, K, M, T tolerance.
 - CAPACITORS:** Indicated in capacity (μF/voltage (V) unless otherwise noted; p, n, f, indication without voltage is 50V except electrolytic capacitor.
 - VOLTAGE CURRENT:** DC voltage (V) at no input signal.
 - OTHERS:**
 - Signal route.
 - Adjusting point.
- The Δ mark found on some component parts indicates the importance of the safety factor of the part. Therefore, when replacing, be sure to use parts of identical designation. # marked capacitors and resistors have parts numbers.
- This is the basic schematic diagram, but the actual circuit may vary due to improvements in design.
- SWITCHES:**
- TAPE TRANSPORT UNIT**
- S1 : PLAY PLAY - STOP
 - S2 : FF FF - OFF
 - S3 : REC ON - OFF
- DECK ASSEMBLY**
- S301(2/2) : TAPE SELECTOR NORM
 - S302(4/4) : TAPE SELECTOR Cr2
 - S303(4/4) : TAPE SELECTOR METAL
 - S304(2/2) : TAPE SELECTOR METAL NORM - Cr2 - METAL
 - S304(2/2) : DOLBY NR ON - OFF
 - S305(8/8) : REC/PB SELECTOR RECORDING - PLAYBACK (7/8 - VACANCY)
- CONTROL ASSEMBLY**
- SH01 : FUNCTION SELECTOR TAPE
 - SH02 : FUNCTION SELECTOR TUNER
 - SH03 : FUNCTION SELECTOR PHONO
- POWER SWITCH ASSEMBLY**
- S601 : POWER ON - OFF
- The underlined indicates the switch position.

External Appearance of Transistors and ICs

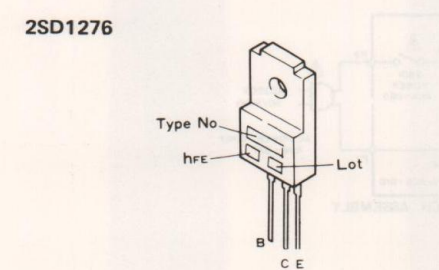
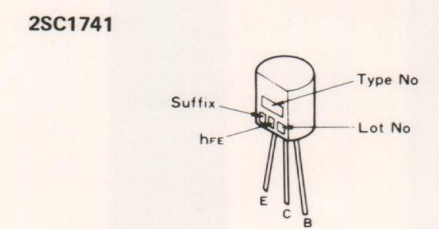
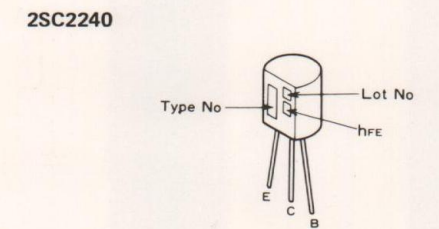
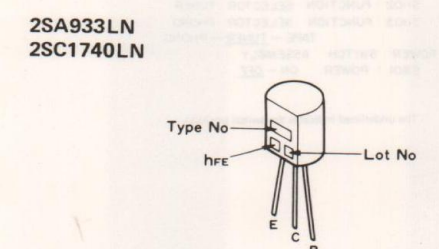
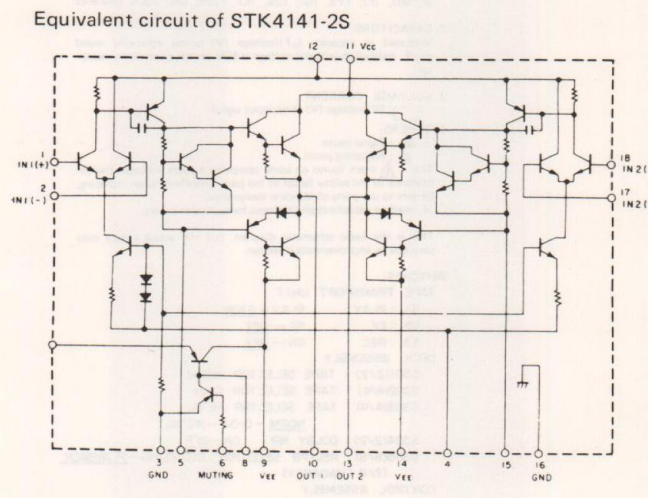
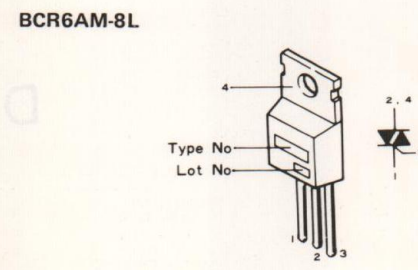
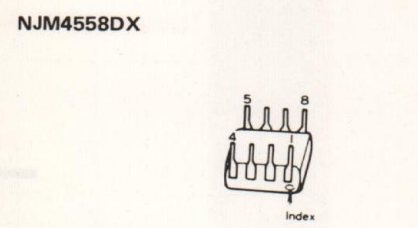
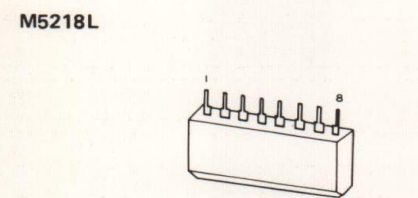
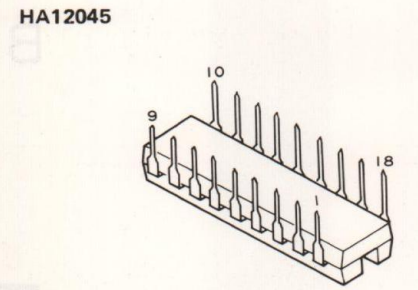
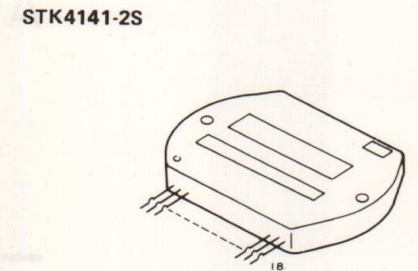

10. BLOCK DIAGRAM

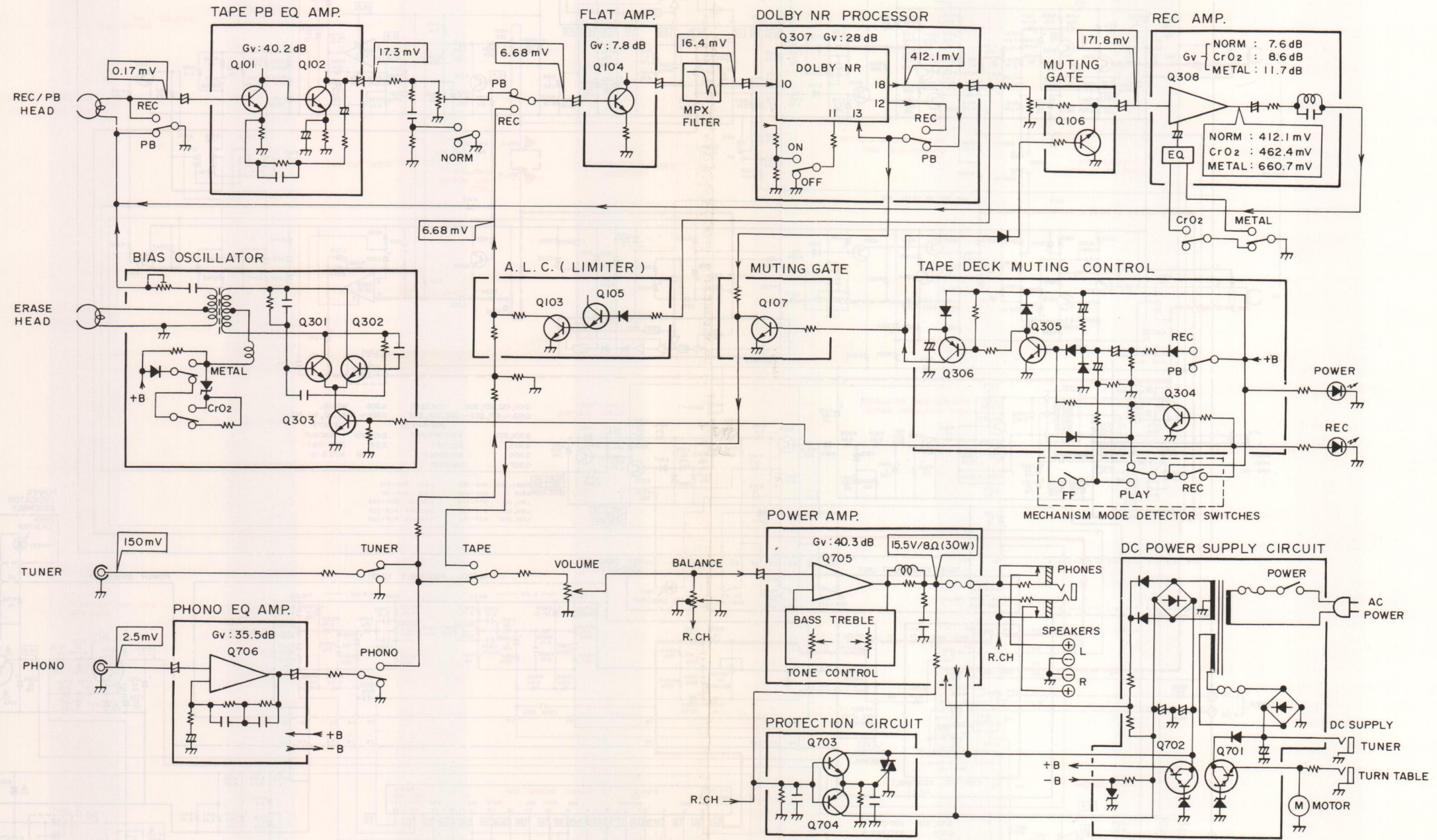

11. ADJUSTMENTS

11.1 MECHANICAL ADJUSTMENTS

Prior to Adjustment

Clean the both reel base, the capstan and the pinch roller with an alcohol moistened swab.

Pinch Roller Pressure Adjustment

1. Put the tape deck into the play back mode.
2. Gently push against the pinch roller arm with the tension gauge and separate the pinch roller slightly from the capstan.
3. Then the pinch roller back onto the capstan, and read the value when the pinch roller starts to rotate. If the reading fails to lie within 300–500g, replace the pinch pressure spring.

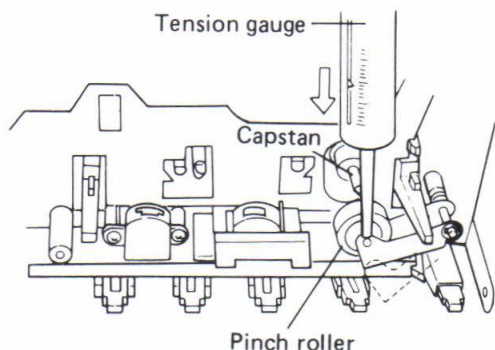

Fig. 11-1 Pinch roller pressure adjustment

Reel Base Torque Adjustment

Measure the torque with the torque meter during playback, fast forward (FF) and rewind (REW) modes. The measured values should normally lie within the allowable ranges listed in the table 1.

If the measured values lie outside the relevant ranges, replace the TU (take-up) reel base assembly and/or supply reel base assembly, TU idler, or drive arm full assembly.

Table 1

	TU reel base	Supply reel base
Playback mode	38 – 57g.cm	* 1.5 – 5g.cm
FF mode	75 – 135g.cm	* 1.5 – 5g.cm
REW mode	* 1.5 – 5g.cm	75 – 135g.cm

*Denotes back tension torque.

REC Switch Adjustment

1. Depress REC button. REC action lever moves to A direction. At this time, check that REC switch is ON.
2. Depress STOP button. The REC action lever moves slightly to B direction. At this time, bend and adjust the REC action lever so that a contact distance of REC switch is 0.2~0.5mm.

NOTE:

Tape speed is increased by turning the semi-fixed resistor clockwise, and decreased by turning counter-clockwise.

Tape Speed Adjustment

1. Connect the frequency counter to the DOL L terminal on the deck assembly.
2. Play back the 3kHz portion of the STD-301 test tape. At the beginning, the frequency should lie within the 3000Hz~3010Hz range, and may be adjusted by turning the semi-fixed resistor located in the capstan motor adjustment hole as shown in Fig. 11-2.

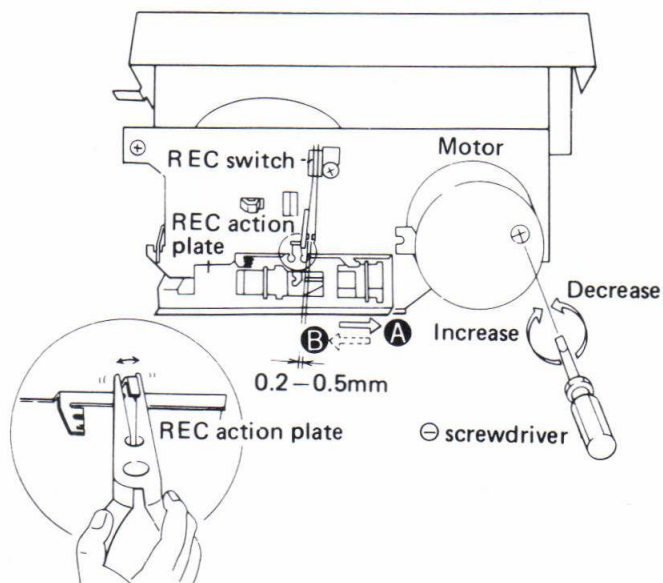

Fig. 11-2 Tape speed and REC switch adjustment

Door Dampening Check and Adjustment

1. Press the EJECT button without a cassette loaded in the cassette compartment, and check that the door opens smoothly without stepwise movement, or rebounding after fully opening.
2. If these conditions are not satisfied, adjust by turning the adjustment screw in the head of the cylinder.

Turn the screw counter clockwise if the door opens stepwise in two stages.

Turn the screw clockwise if the door bounces back after fully opening.

REC Joint Check and Adjustment

1. Check that the gap F between the REC joint and slide switch is 0 to 0.3mm when the transport mechanism is stationary (and check that the slide switch does not move).
2. Move the REC joint mechanism catching position backwards if the gap F is greater than 1.0mm, but move it forwards if there is no gap and the slide switch is moving.
3. If the prescribed gap F cannot be obtained by the above adjustment, bend the hook section of the REC joint with a pair of pliers by an appropriate degree.
4. Check that the slide switch is fully switched when the transport mechanism is in recording mode.
5. Also check that the mechanism spring switch is shorted.

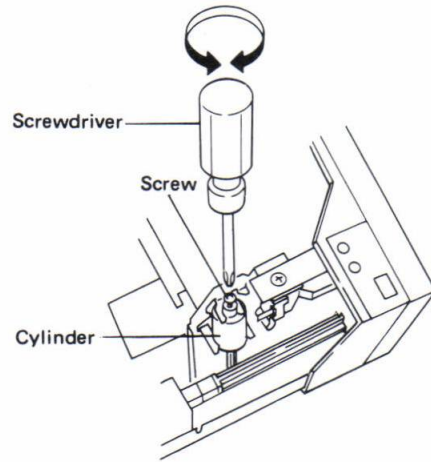

Fig. 11-3 Door damping check and adjustment

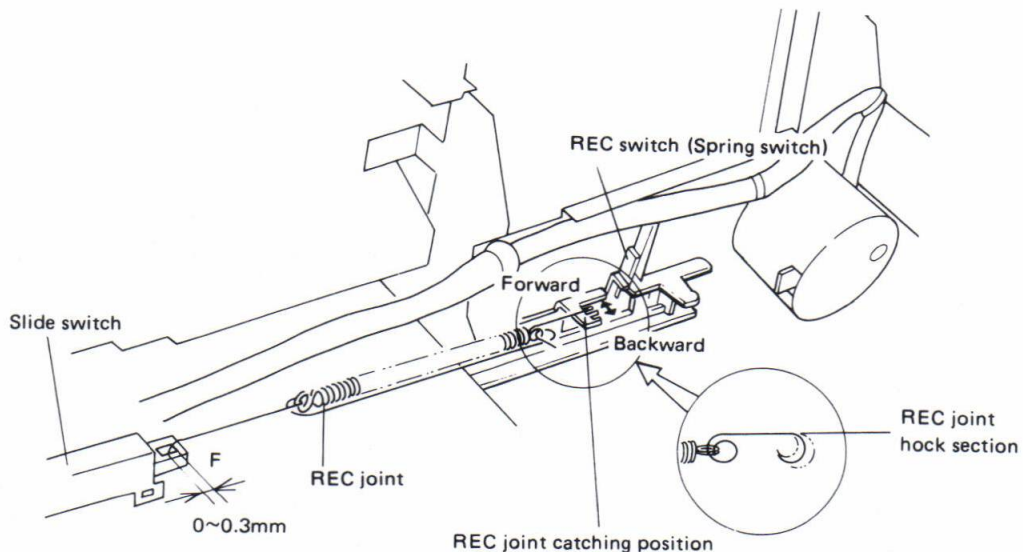

Fig. 11-4 Rec joint check and adjustment

11.2 ELECTRICAL ADJUSTMENTS

Adjustment Conditions

1. The mechanical adjustments must be completed first.
2. The head must be cleaned and demagnetized.
3. Allow the deck to age for at least a few minutes before commencing any electrical adjustments.
4. The reference signal is 0dBv = 1Vrms.
5. Unless otherwise specified, the switches listed below are to left in the positions indicated.

FUNCTION : TAPE
 DOLBY NR : OFF
 TAPE SELECTOR : NORM

Test Tapes

- STD-331B : Playback adjustments (See Fig. 11-5)
 STD-608A : NORMAL blank tape
 STD-603 : CrO₂ blank tape
 STD-610 : METAL blank tape

List of Adjustments

1. Head azimuth adjustment.
2. Playback equalizer check.
3. Playback level adjustment.
4. Recording and playback frequency response adjustment.
5. Recording level adjustment.
6. Limiter effect check.

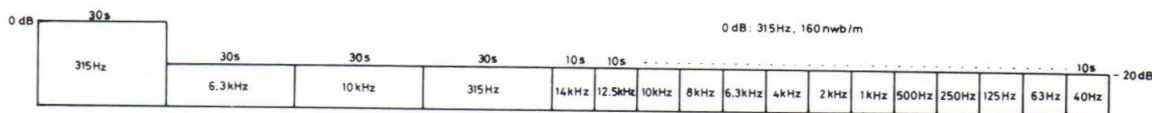

Fig. 11-5 Contents of the test tape STD-331B

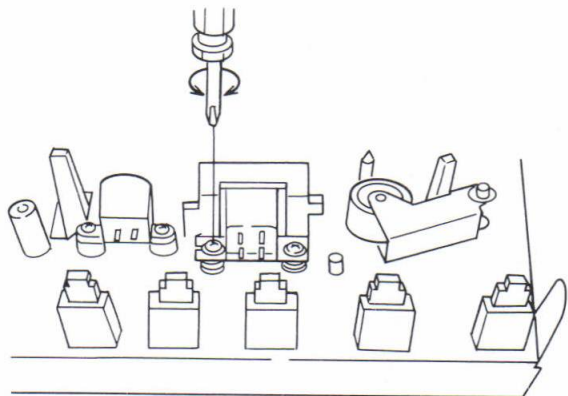

Fig. 11-6 Head azimuth adjustment

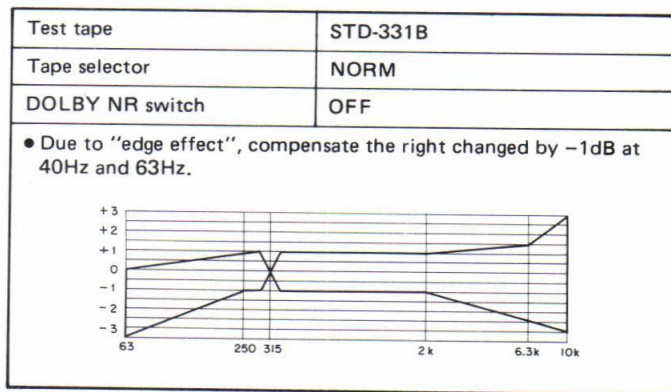

Fig. 11-7 Allowable playback frequency response zone

- Set the DOLBY NR switch to the OFF position.

1. Head Azimuth Adjustment						
• Turn V101 and V201 to maximum position (fully clockwise).						
	Mode	Input signal & test tape	Adjustment location	Measuring location	Adjustment value	Remarks
1	STOP	Set the TAPE SELECTOR switch to the NORM position.				
2	PLAY	Play the 10kHz/-20dB section of the STD-331B test tape.	Head azimuth adjustment screw. (See Fig. 11-6)	DOL. L (L ch.) DOL. R (R ch.)	Maximum playback signal level.	
3	STOP	Lock the screw with screw lock after completing the adjustment.				
2. Playback Equalizer Check						
	Mode	Input signal & test tape	Adjustment location	Measuring location	Adjustment value	Remarks
1	STOP	Set the TAPE SELECTOR switch to the NORM position.				
2	PLAY	Play the 315Hz/-20dB and 6.3kHz/-20dB sections of the STD-331B test tape.	Confirm	DOL. L (L ch.) DOL. R (R ch.)	The 6.3kHz playback level is $-0.5 \pm 2\text{dB}$ against 315Hz level.	
3	STOP	Set the TAPE SELECTOR switch to the CrO ₂ or METAL position.				
4	PLAY	Play the 315Hz/-20dB and 6.3kHz/-20dB sections of the STD-331B test tape.	Confirm	DOL. L (L ch.) DOL. R (R ch.)	The 6.3kHz playback level is $-4.5 \pm 2\text{dB}$ against 315Hz level.	

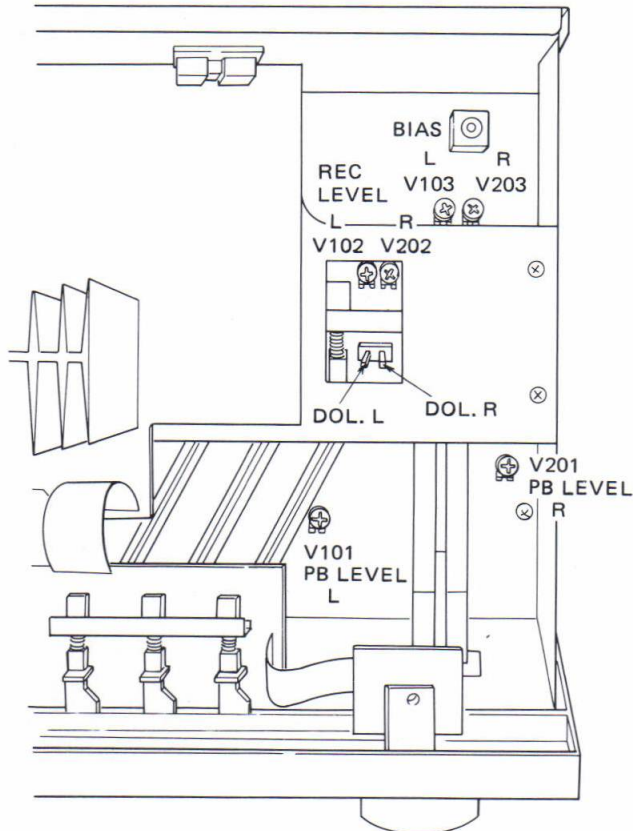
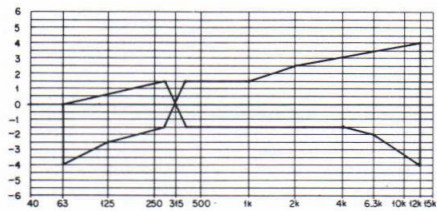

Fig. 11-8 Adjustments location

3. Playback Level Adjustment						
● This adjustment determines the DOLBY NR level, and must be performed with great care.						
Mode	Input signal & test tape	Adjustment location	Measuring location	Adjustment value	Remarks	
1	STOP	Set the TAPE SELECTOR switch to the NORM position.				
2	PLAY	Play the 315Hz/0dB section of the STD-331B test tape.	V101 (Left channel) V201 (Right channel)	DOL. L (L ch.) DOL. R (R ch.)	-7.7dBv (412.1mV)	
4. Recording and Playback Frequency Response Adjustment						
Mode	Input signal & test tape	Adjustment location	Measuring location	Adjustment value	Remarks	
1	STOP	Set the TAPE SELECTOR switch to the NORM position. Set the FUNCTION switch to the TUNER position.				
2	REC-PAUSE	Apply a 315Hz/-30dBv (31.6mV) signal to the TUNER INPUT terminals.	Confirm	DOL. L (L ch.) DOL. R (R ch.)	Approx. -27.7dBv (41.2mV)	
3	REC/PLAY	Record the above signal level onto the STD-608A test tape at 315Hz and 6.3kHz, and play back.	V103 (Left channel) V203 (Right channel)	DOL. L (L ch.) DOL. R (R ch.)	Adjust the 6.3kHz playback level to $0^{+1}_{-0.5}$ dB higher than the 315Hz level.	
4		Record and play back signals up to 12kHz onto the STD-608A test tape, and check that the allowable frequency response zone shown in Fig. 11-9 is satisfied.				
5		Set the DOLBY NR switch to the ON positions. Record and play back signals up to 10kHz onto the STD-608A test tape, and check that the allowable frequency response zone shown in Fig. 11-9 is satisfied.				
6		Set the TAPE SELECTOR switch to the CrO ₂ position. Record and play back signals up to 12kHz onto the STD-603 test tape, and check that the allowable frequency response zone shown in Fig. 11-10 is satisfied (for DOLBY NR ON and OFF).				
7		Set the TAPE SELECTOR switch to the METAL position. Record and play back signals up to 12kHz onto the STD-610 test tape, and check that the allowable frequency response zone shown in Fig. 11-11 is satisfied (for DOLBY NR ON, and OFF).				
5. Recording Level Adjustment						
Mode	Input signal & test tape	Adjustment location	Measuring location	Adjustment value	Remarks	
1	STOP	Set the TAPE SELECTOR switch to the NORM position. Set the FUNCTION switch to the TUNER position.				
2	REC-PAUSE	Apply a 315Hz signal to the TUNER INPUT terminals.	Vary the input signal level.	DOL. L (L ch.) DOL. R (R ch.)	-7.7dBv (412.1mV)	The input signal level is approx. -10dBv.
3		Set the DOLBY NR switch to the ON position.				
4	REC/PLAY	Record the above signal level onto the STD-608A test tape, and play back.	V102 (Left channel) V202 (Right channel)	DOL. L (L ch.) DOL. R (R ch.)	-7.7dBv (412.1mV)	
5		Set the TAPE SELECTOR switch to the CrO ₂ position.				
6		Record the above signal onto the STD-603 test tape, and play back.	Confirm	DOL. L (L ch.) DOL. R (R ch.)	-7.7dBv±1.5dB	
7		Set the TAPE SELECTOR switch to the METAL position.				
8		Record the above signal onto the STD-610 test tape, and play back.	Confirm	DOL. L (L ch.) DOL. R (R ch.)	-7.7dBv±1.5dB	
6. Limiter Effect Check						
Mode	Input signal & test tape	Adjustment location	Measuring location	Adjustment value	Remarks	
1	STOP	Set the TAPE SELECTOR switch to the NORM position. Set the FUNCTION switch to the TUNER position.				
2	REC-PAUSE	Apply a 1kHz signal to the TUNER INPUT terminals.	Vary the input signal level.	DOL. L (L ch.) DOL. R (R ch.)	-7.7dBv (412.1mV)	The input signal level is approx. -10dBv.
3		Increase the input signal level to +10dB higher than the level of Step 2.	Confirm	DOL. L (L ch.) DOL. R (R ch.)	-2.3dBv±1.5dB	The input signal level is approx. 0dBv.

Test tape	STD-608A
Tape selector	NORM
DOLBY NR switch	OFF



Test tape	STD-608A
Tape selector	NORM
DOLBY NR switch	ON

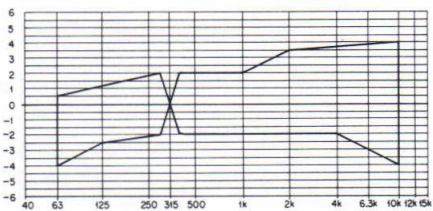
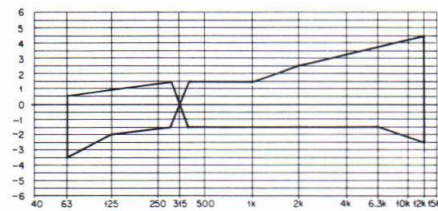

Fig. 11-9 Allowable recording and playback frequency response zone (NORM)

Test tape	STD-610
Tape selector	METAL
DOLBY NR switch	OFF



Test tape	STD-610
Tape selector	METAL
DOLBY NR switch	ON

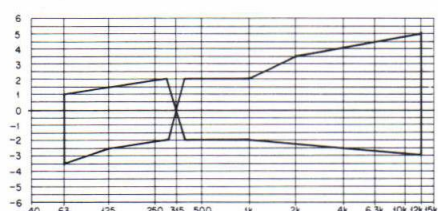
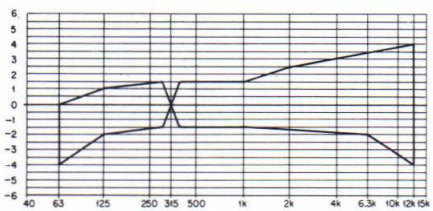

Fig. 11-11 Allowable recording and playback frequency response zone (METAL)

Test tape	STD-603
Tape selector	CrO ₂
DOLBY NR switch	OFF



Test tape	STD-603
Tape selector	CrO ₂
DOLBY NR switch	ON

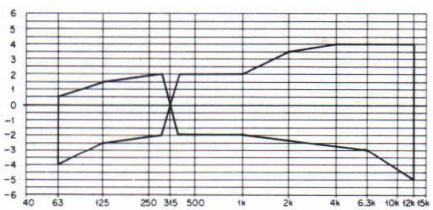

Fig. 11-10 Allowable recording and playback frequency response zone (CrO₂)

11. RÉGLAGES

11.1 RÉGLAGES DES MÉCANISMES

Avant de faire les réglages

Nettoyer les deux supports de bobine, le cabestan et le galet-presseur avec un bâtonnet imprégné d'alcool.

Réglage de pression du galet-presseur

1. Régler la platine-cassette en mode de lecture.
2. Repousser progressivement le bras supportant le galet-presseur à l'aide du tensiomètre et séparer légèrement le galet-presseur du cabestan.
3. Laisser revenir le galet-presseur contre le cabestan et interpréter la valeur indiquée dès que le galet-presseur commence à tourner. Si l'indication obtenue ne se trouve pas dans les limites de 300 à 500 gr., remplacer le ressort du galet-presseur.

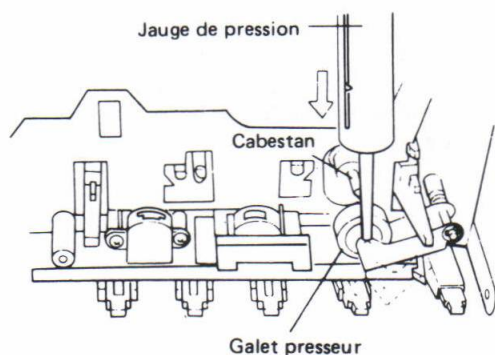

Fig. 11-1 Réglage de la force d'appui du galet presseur

Réglage du couple de support de bobine

Mesurer le couple du support de bobine à l'aide d'un couplemètre au cours des modes de lecture, avance rapide (FF) et de retour rapide (REW). Les valeurs relevées doivent normalement se trouver dans les limites admissibles qui sont indiquées dans le tableau 1.

Si les valeurs mesurées sont en-dehors de la gamme indiquée, remplacer l'ensemble support de bobine réceptrice (TU) et/ou l'ensemble support de bobine débitrice, la poulie intermédiaire TU ou l'ensemble complet du bras d'entraînement.

Tableau 1

	Support de bobine débitrice	Support de bobine réceptrice
Mode de lecture	38 à 57 gr.cm	*1,5 à 5 gr.cm
Mode d'avance rapide	75 à 135 gr.cm	*1,5 à 5 gr.cm
Mode de retour rapide	*1,5 à 5 gr.cm	75 à 135 gr.cm

* Indiquent des valeurs de contre-tension.

Réglage du commutateur d'enregistrement "REC"

1. Appuyer sur la touche d'enregistrement (REC). Le levier de commande d'enregistrement se déplace dans la direction **A**. Quand ces conditions sont obtenues, vérifier si le commutateur d'enregistrement est enclenché.
2. Appuyer sur la touche d'arrêt (STOP). Le levier de commande d'enregistrement se déplace dans la direction **B**. Quand ces conditions sont obtenues, replier et ajuster le levier de commande d'enregistrement pour que la distance nécessaire à la mise en contact du commutateur d'enregistrement soit comprise entre 0,2 et 0,5mm.

REMARQUE:

La vitesse de défilement de la bande augmente lorsque la résistance variable est tournée dans le sens des aiguilles d'une montre et diminue lorsque la résistance est tournée dans le contraire des aiguilles d'une montre.

Réglage de la vitesse de défilement de la bande

1. Raccorder un fréquencemètre à la prise "DOL. L" de l'ensemble platine.
2. Lire le passage préenregistré de 3kHz de la bande d'étalonnage STD-301. Dès le début, la fréquence indiquée doit se trouver entre 3000 et 3010Hz, celle-ci pouvant être ajustée en tournant la résistance ajustable qui se trouve dans le trou de réglage du moteur d'entraînement du cabestan, comme représenté sur la figure 11-2.

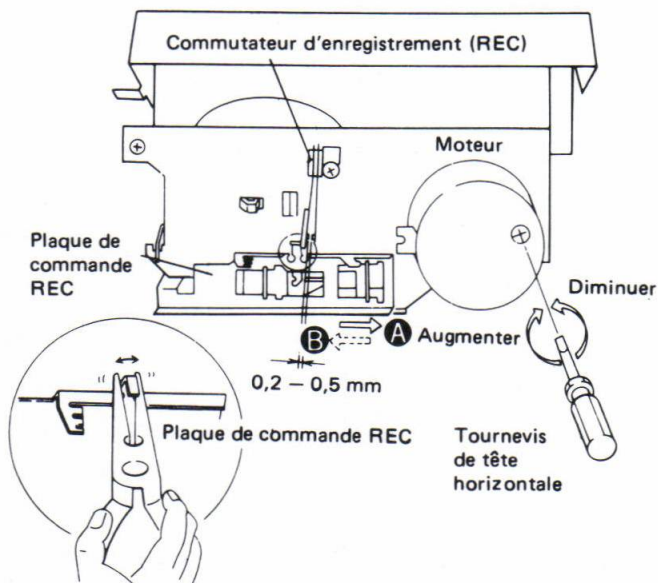

Fig. 11-2 Réglage de la vitesse de défilement de la bande et du commutateur d'enregistrement (REC)

Contrôle et réglage d'amortissement de la trappe à cassettes

1. Appuyer sur la touche d'éjection (EJECT) sans charger de cassette dans la trappe à cassettes et vérifier si la trappe s'ouvre normalement, progressivement et sans à-coups ni rebonds après son ouverture totale.
2. Si ces conditions ne sont pas satisfaites, effectuer un réglage à l'aide de la vis incorporée à la tête du cylindre.

Tourner la vis dans le sens contraire des aiguilles d'une montre si la trappe s'ouvre par à-coups en deux étapes.

Tourner la vis dans le sens des aiguilles d'une montre si la trappe rebondit après s'être ouverte complètement.

Contrôle et réglage du raccord d'enregistrement

1. Vérifier si l'écartement F entre le raccord d'enregistrement et le commutateur à curseur se trouve entre 0 et 0,3mm lorsque le mécanisme d'entraînement est immobile et contrôler si le commutateur à curseur ne bouge pas.
2. Déplacer la position d'accrochage du mécanisme d'enregistrement vers l'arrière si l'écartement F est supérieur à 1mm et la déplacer vers l'avant quand il n'a aucun écart et que le commutateur à curseur bouge.
3. Si l'écartement F décrit plus haut ne peut pas être obtenu en procédant à ce réglage, replier la section du crochet de raccord d'enregistrement avec un paire de pinces sur la longueur appropriée.
4. Vérifier si le commutateur à curseur est parfaitement enclenché lorsque le mécanisme d'entraînement est placé en position d'enregistrement.
5. Vérifier également si le commutateur du ressort du mécanisme d'entraînement est court-circuité.

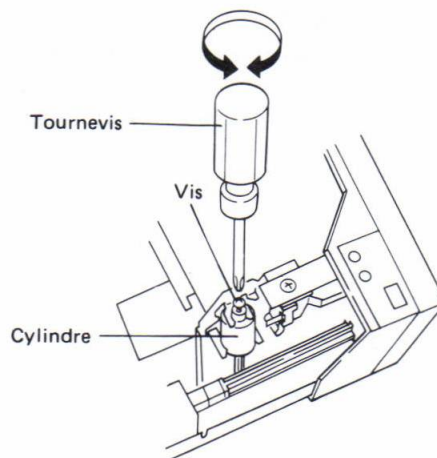

Fig. 11-3 Contrôle et réglage de l'amortissement de la trappe

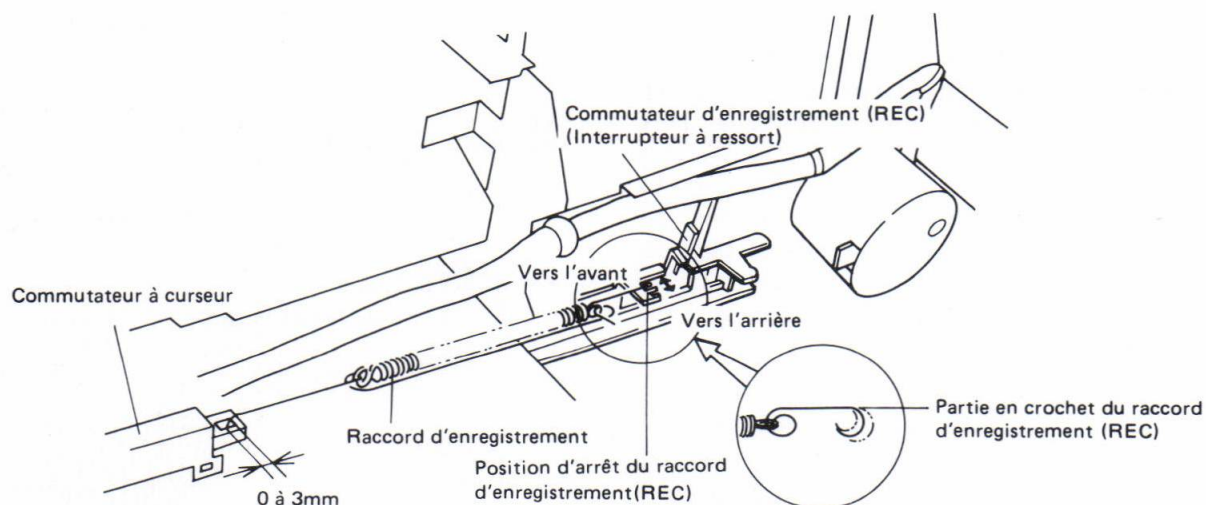

Fig. 11-4 Contrôle et réglage du raccord d'enregistrement

11.2 RÉGLAGES ÉLECTRIQUES

Conditions nécessaires pour effectuer les réglages

1. Les réglages des mécanismes doivent avoir été faits avant.
2. La tête magnétique doit être propre et démagnétisée.
3. La platine-cassette doit avoir fonctionné pendant quelques minutes avant de commencer les réglages électriques.
4. Le signal de référence est de 0dB=1V effi.
5. A moins d'une indication contraire, les commutateurs mentionnés ci-dessous doivent se trouver dans la position indiquée.

FUNCTION : Sur TAPE

DOLBY NR : Sur OFF

TAPE SELECTOR : Sur NORM

Liste des réglages à exécuter

1. Réglage d'azimut de tête magnétique
2. Contrôle de l'égaliseur de lecture
3. Réglage de niveau de lecture
4. Calage de réponse en fréquence d'enregistrement et de lecture
5. Réglage du niveau d'enregistrement
6. Contrôle d'effet limiteur.

Bandes de mesure

STD-331B : Réglages de lecture (Fig. 11-5)

STD-608A : Bande vierge ordinaire (NORMAL)

STD-603 : Bande vierge au chrome (CrO₂)

STD-610 : Bande vierge au fer (METAL)

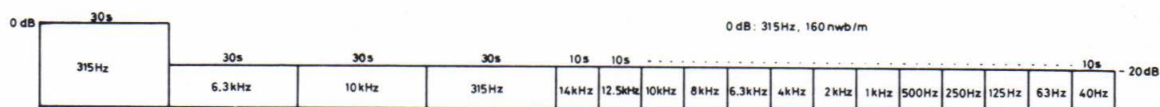

Fig. 11-5 Signaux préenregistrés sur la bande d'étalonnage STD-331B

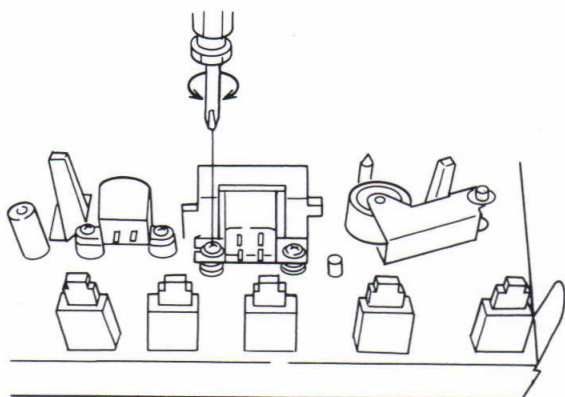

Fig. 11-6 Réglage d'azimut de tête magnétique

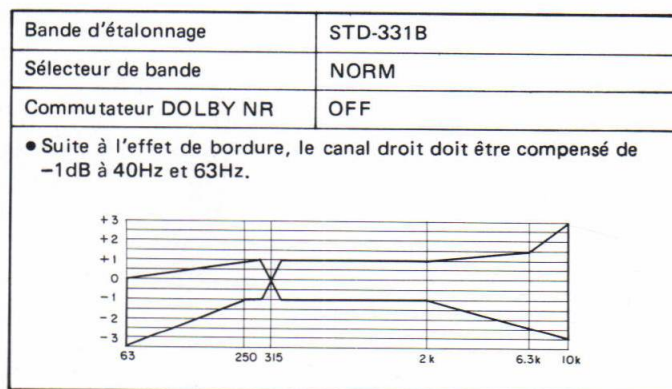

Fig. 11-7 Réponse en fréquence admissible en lecture

• Le commutateur DOLBY NR doit être placé en position OFF.

1. Réglage d'azimut de la tête magnétique.						
• Tourner V101 et V201 sur leur position maximum (dans le sens maximum des aiguilles d'une montre).						
	Mode	Signal injecté et bande d'étalonnage	Emplacement du composant de réglage	Emplacement de la borne de mesure	Valeur relevée	Observations
1	ARRÊT	Placer le sélecteur de bande (TAPE SELECTOR) en position "NORM".				
2	LECTURE	Lire le passage préenregistré de 10kHz/-20dB de la bande d'étalonnage STD-331B.	Vis de réglage d'azimut de tête. (Consulter la figure 11-6)	DOL, L (canal gauche) DOL, R (canal droit)	Niveau maximal du signal de lecture.	
3	ARRÊT	Bloquer la vis de réglage à la peinture lorsque le réglage est terminé.				
2. Contrôle de l'égaliseur de lecture.						
	Mode	Signal injecté et bande d'étalonnage	Emplacement du composant de réglage	Emplacement de la borne de mesure	Valeur relevée	Observations
1	ARRÊT	Placer le sélecteur de bande (TAPE SELECTOR) en position "NORM".				
2	LECTURE	Lire les passages préenregistrés de 315kHz/-20dB et de 6,3kHz/-20dB de la bande d'étalonnage STD-331B.	Contrôler	DOL, L (canal gauche) DOL, R (canal droit)	Le niveau de lecture de 6,3kHz est de $-0,5 \pm 2$ dB par rapport au niveau de 315Hz.	
3	ARRÊT	Placer le sélecteur de bande (TAPE SELECTOR) en position "CrO ₂ " ou "METAL".				
4	LECTURE	Lire les passages préenregistrés de 315kHz/-20dB et de 6,3kHz/-20dB de la bande d'étalonnage STD-331B.	Contrôler	DOL, L (canal gauche) DOL, R (canal droit)	Le niveau de lecture de 6,3kHz est de $-4,5 \pm 2$ dB par rapport au niveau de 315Hz.	

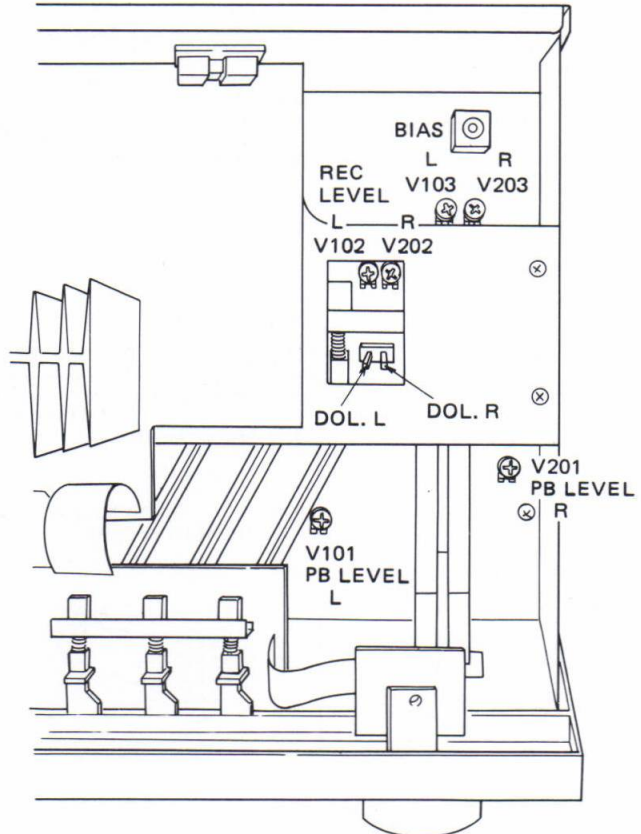
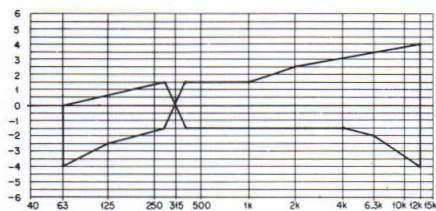

Fig. 11-8 Emplacement des composants de réglage

3. Réglage du niveau de lecture						
• Ce réglage servant à étalonner le niveau DOLBY NR doit être exécuté avec un grand soin.						
Mode	Signal injecté et bande d'étalonnage	Emplacement du composant de réglage	Emplacement de la borne de mesure	Valeur relevée	Observations	
1	ARRÊT	Placer le sélecteur de bande (TAPE SELECTOR) en position "NORM".				
2	LECTURE	Lire le passage préenregistré de 315kHz/0dB de la bande d'étalonnage STD-331B.	V101 (canal gauche) V201 (canal droit)	DOL, L (canal gauche) DOL, R (canal droit)	-7,7dBv (412,1mV)	
4. Calage de réponse en fréquence d'enregistrement et de lecture.						
Mode	Signal injecté et bande d'étalonnage	Emplacement du composant de réglage	Emplacement de la borne de mesure	Valeur relevée	Observations	
1	ARRÊT	Placer le sélecteur de bande (TAPE SELECTOR) en position "NORM". Placer le sélecteur de source (FUNCTION) en position "TUNER".				
2	PAUSE À L'EN-REGISTREMENT	Injecter un signal de 315Hz/ -30dBv (31,6mV) par les bornes d'entrée de syntoniseur "TUNER INPUT".	Contrôler	DOL, L (canal gauche) DOL, R (canal droit)	Environ -27,2dBv (41,2mV)	
3	EN-REGISTREMENT/LECTURE	Enregistrer le niveau de signal indiqué plus haut sur la bande d'étalonnage STD-608A à 315Hz et 6,3 kHz et lire ce passage.	V103 (canal gauche) V203 (canal droit)	DOL, L (canal gauche) DOL, R (canal droit)	Ajuster le niveau de lecture du signal 6,3kHz à $0_{-0,5}^{+1}$ dB ou au-dessus du niveau de 315Hz.	
4	Enregistrer et lire le signal jusqu'à 12kHz sur la bande d'étalonnage STD-608A et contrôler si la zone de réponse en fréquence admissible qui est représentée sur la courbe de la figure 11-9 est satisfaite.					
5	Régler le commutateur DOLBY NR en position ON. Enregistrer et lire les signaux jusqu'à 10kHz sur la bande d'étalonnage STD-608A et contrôler si la zone de réponse en fréquence admissible qui est représentée sur la courbe de la figure 11-9 est satisfaite.					
6	Placer le sélecteur de bande (TAPE SELECTOR) en position "CrO ₂ ". Enregistrer et lire les signaux jusqu'à 12kHz sur la bande d'étalonnage STD-603 et contrôler si la zone de réponse en fréquence admissible qui est représentée sur la courbe de la figure 11-10 est satisfaite (lorsque le commutateur DOLBY NR est en position ON et position OFF.)					
7	Placer le sélecteur de bande (TAPE SELECTOR) en position "METAL". Enregistrer et lire les signaux jusqu'à 12kHz sur la bande d'étalonnage STD-610 et contrôler si la zone de réponse en fréquence admissible qui est représentée sur la courbe de la figure 11-11 est satisfaite (lorsque le commutateur DOLBY NR est en position ON et position OFF.)					
5. Réglage du niveau d'enregistrement.						
Mode	Signal injecté et bande d'étalonnage	Emplacement du composant de réglage	Emplacement de la borne de mesure	Valeur relevée	Observations	
1	ARRÊT	Placer le sélecteur de bande (TAPE SELECTOR) en position "NORM". Placer le sélecteur de source (FUNCTION) en position "TUNER".				
2	PAUSE À L'EN-REGISTREMENT	Injecter un signal de 315Hz par les bornes d'entrée de syntoniseur "TUNER INPUT".	Faire varier le niveau du signal injecté.	DOL, L (canal gauche) DOL, R (canal droit)	-7,7dBv (412,1mV)	Le niveau du signal injecté est approximativement de -10dBv.
3	Régler le commutateur DOLBY NR en position ON.					
4	EN-REGISTREMENT/LECTURE	Enregistrer le niveau de signal indiqué plus haut sur la bande d'étalonnage STD-608A et lire ce passage.	V102 (canal gauche) V202 (canal droit)	DOL, L (canal gauche) DOL, R (canal droit)	-7,7dBv (412,1mV)	
5	Placer le sélecteur de bande (TAPE SELECTOR) en position "CrO ₂ ".					
6	EN-REGISTREMENT/LECTURE	Enregistrer le niveau de signal indiqué plus haut sur la bande d'étalonnage STD-603 et lire ce passage.	Contrôler	DOL, L (canal gauche) DOL, R (canal droit)	-7,7dBv±1,5dB	
7	Placer le sélecteur de bande (TAPE SELECTOR) en position "METAL".					
8	EN-REGISTREMENT/LECTURE	Enregistrer le niveau de signal indiqué plus haut sur la bande d'étalonnage STD-610 et lire ce passage.	Contrôler	DOL, L (canal gauche) DOL, R (canal droit)	-7,7dBv±1,5dB	
6. Contrôle de l'effet limiteur.						
Mode	Signal injecté et bande d'étalonnage	Emplacement du composant de réglage	Emplacement de la borne de mesure	Valeur relevée	Observations	
1	ARRÊT	Placer le sélecteur de bande (TAPE SELECTOR) en position "NORM". Placer le sélecteur de source (FUNCTION) en position "TUNER".				
2	PAUSE À L'EN-REGISTREMENT	Injecter un signal de 1kHz par les bornes d'entrée de syntoniseur "TUNER INPUT".	Faire varier le niveau du signal injecté.	DOL, L (canal gauche) DOL, R (canal droit)	-7,7dBv (412,1mV)	Le niveau du signal injecté est approximativement de -10dBv.
3	EN-REGISTREMENT/LECTURE	Accroître le niveau du signal injecté de plus de +10dB de plus que le réglage effectué au cours de l'opération 2.	Contrôler	DOL, L (canal gauche) DOL, R (canal droit)	-2,3dBv±1,5dB	Le niveau du signal injecté est approximativement de 0dBv.

Bande d'étalonnage	STD-608A
Sélecteur de bande	NORM
Commutateur DOLBY NR	OFF



Bande d'étalonnage	STD-608A
Sélecteur de bande	NORM
Commutateur DOLBY NR	ON

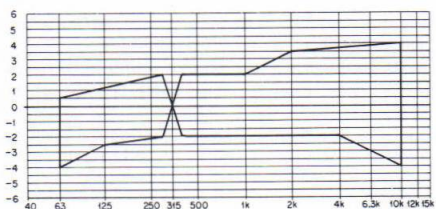
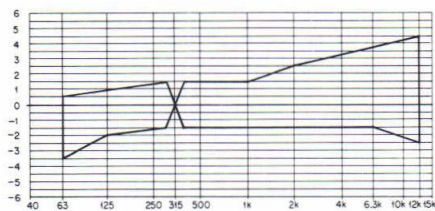

Fig. 11-9 Zone de réponse en fréquence admissible de lecture et d'enregistrement (NORM)

Bande d'étalonnage	STD-610
Sélecteur de bande	METAL
Commutateur DOLBY NR	OFF



Bande d'étalonnage	STD-610
Sélecteur de bande	METAL
Commutateur DOLBY NR	ON

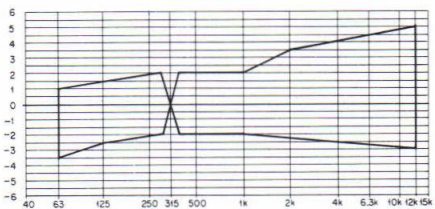
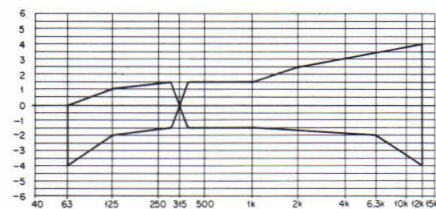

Fig. 11-11 Zone de réponse en fréquence admissible de lecture et d'enregistrement (METAL)

Bande d'étalonnage	STD-603
Sélecteur de bande	CrO ₂
Commutateur DOLBY NR	OFF



Bande d'étalonnage	STD-603
Sélecteur de bande	CrO ₂
Commutateur DOLBY NR	ON

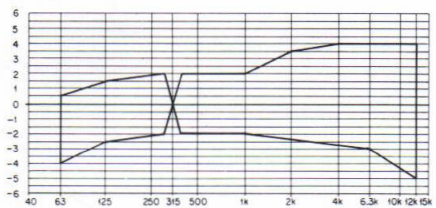

Fig. 11-10 Zone de réponse en fréquence admissible de lecture et d'enregistrement (CrO₂)

11. AJUSTES

11.1 AJUSTES MECANICOS

Antes del ajuste

Limpiar ambas bases de los carretes, el eje de arrastre y el rodillo de presión con algodón remojado en alcohol.

Ajuste de la presión del rodillo de presión

1. Establecer el magnetófono en el modo de reproducción.
2. Con el calibrador de tensión, presionar ligeramente contra el brazo del rodillo de presión y separar un poco dicho rodillo del eje de arrastre.
3. Luego reponer el rodillo de presión sobre el eje de arrastre, y leer el valor en el momento que el rodillo de presión empieza a girar. Si la indicación no está dentro de 300–500g, reemplazar el muelle del rodillo de presión.

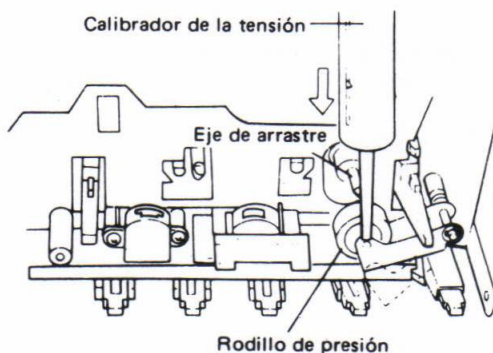

Fig. 11-1 Ajuste de la presión del rodillo de presión

Ajuste de la torsión de la base del carrete

Utilizar el medidor de torsión para medir la torsión durante las funciones de reproducción, avance rápido (FF) y rebobinado (REW). Los valores obtenidos deben estar normalmente dentro de los límites permisibles enumerados en la tabla 1.

Si los valores obtenidos no están dentro de tales límites, reemplazar el conjunto de la base del carrete tensor (TU) y/o el conjunto de la base del carrete de suministro, la rueda de guía TU, o todo el conjunto del brazo de arrastre.

Tabla 1

	Base del carrete TU	Base del carrete de suministro
Modo de reproducción	38 – 57g.cm	*1,5 – 5g.cm
Modo de avance rápido	75 – 135g.cm	*1,5 – 5g.cm
Modo de rebobinado	1,5 – 5g.cm	75 – 135g.cm

* Indica par de torsión de contratensión.

Ajuste del interruptor de grabación (REC)

1. Presionar el botón REC. La palanca de accionamiento de REC se mueve en la dirección **A**. En este momento, comprobar que el interruptor REC está en la posición ON.
2. Presionar el botón de parada (STOP). La palanca de accionamiento de REC se mueve ligeramente en la dirección **B**. Entonces, doblar y ajustar la palanca de accionamiento de REC de modo que la distancia de contacto del interruptor REC sea de 0,2~0,5mm.

NOTA:

La velocidad de la cinta aumentará al girar a la derecha el resistor semifijo, y se reducirá al girarlo a la izquierda.

Ajuste de la velocidad de la cinta

1. Conectar el frecuencímetro al terminal DOL. L del conjunto del magnetófono.
2. Reproducir la parte de 3kHz de la cinta de prueba STD-301. Al principio, la frecuencia deberá estar entre 3000Hz~3010Hz, y podrá ajustarse girando el resistor semifijo ubicado en el orificio de ajuste del motor, como se muestra en la Fig. 11-2.

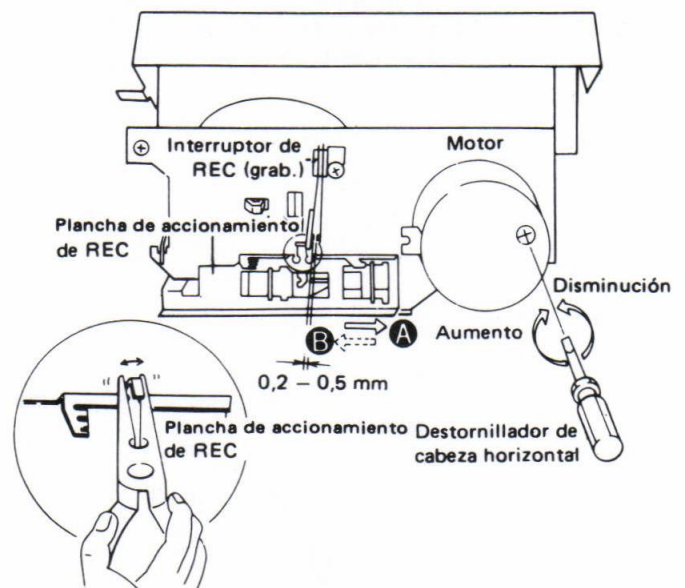

Fig. 11-2 Ajuste de la velocidad de la cinta y del interruptor de grabación (REC)

Comprobación y ajuste del amortiguamiento de la puerta

1. Presionar el botón de expulsión (EJECT) sin haber ningún casete insertado en el compartimiento del casete, y comprobar que la puerta se abre suavemente sin movimientos interrumpidos ni rebote después de haberse abierto por completo.
2. Si no se satisfacen estas condiciones, ajustar girando el tornillo de ajuste del cabezal del cilindro.

Comprobación y ajuste de la unión de grabación REC

1. Comprobar que el entrehierro F entre la unión REC y el conmutador deslizante es de 0 a 0,3 mm cuando el mecanismo de transporte está detenido (y comprobar que no se mueve el conmutador deslizante).
2. Mover la posición de engrane del mecanismo de unión REC hacia atrás si el entrehierro F es mayor a 1mm, y moverla hacia adelante si no hay entrehierro y se mueve el conmutador deslizante.
3. Si el entrehierro F descrito no puede obtenerse mediante el ajuste mencionado, doblar la sección de gancho de la unión REC con un alicates.
4. Comprobar que el conmutador deslizante está completamente conmutado cuando el mecanismo de transporte está en el modo de grabación.
5. Comprobar también que el interruptor de muelle del mecanismo está cortocircuitado.

Girar el tornillo hacia la izquierda si la puerta se abre con interrupciones en dos etapas.

Girar el tornillo hacia la derecha si la puerta rebota después de haberse abierto por completo.

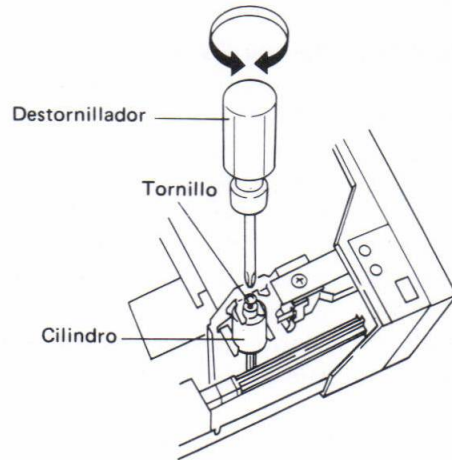

Fig. 11-3 Comprobación y ajuste del amortiguamiento de la puerta

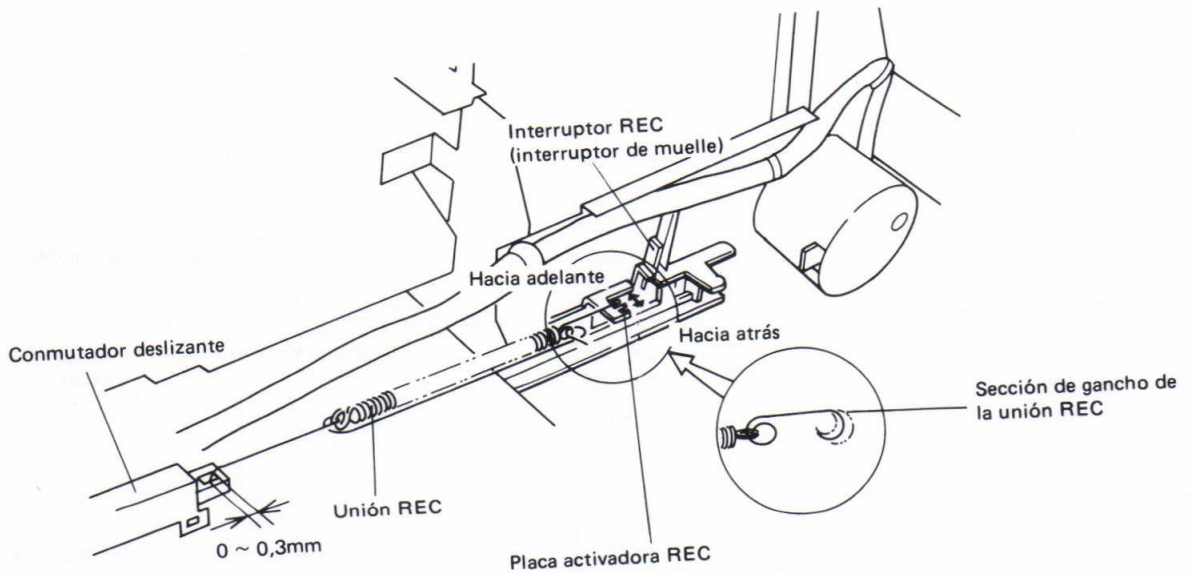

Fig. 11-4 Comprobación y ajuste de la union de grabacion

11.2 AJUSTES ELECTRICOS

Condiciones de ajuste

1. Los ajustes mecánicos deben terminarse primero.
2. Limpiar y desmanar la cabeza de grabación.
3. Dejar que el magnetófono se precaliente por unos minutos antes de iniciar los ajustes eléctricos.
4. La señal de referencia es de 0dB=1Vrms.
5. A menos que se especifique de otra manera, los siguientes interruptores deben estar en las posiciones indicadas:

FUNCION : TAPE
 DOLBY NR : OFF
 SELECTOR DE CINTA : NORM

Cintas de prueba

- STD-331B : Para ajustes de reproducción (Referirse a la Fig. 11-5)
 STD-608A : Cinta NORMAL en blanco.
 STD-603 : Cinta CrO₂ en blanco.
 STD-610 : Cinta de METAL en blanco.

Lista de ajustes y comprobaciones

1. Ajuste azimutal de la cabeza de grabación
2. Comprobación del ecualizador de reproducción
3. Ajuste del nivel de reproducción
4. Ajuste de la respuesta de frecuencia de grabación y reproducción
5. Ajuste del nivel de grabación
6. Comprobación del efecto del limitador.

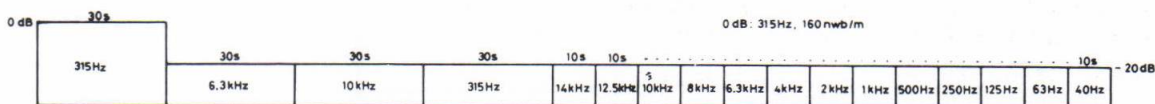

Fig. 11-5 Contenido de la cinta de prueba STD-331B

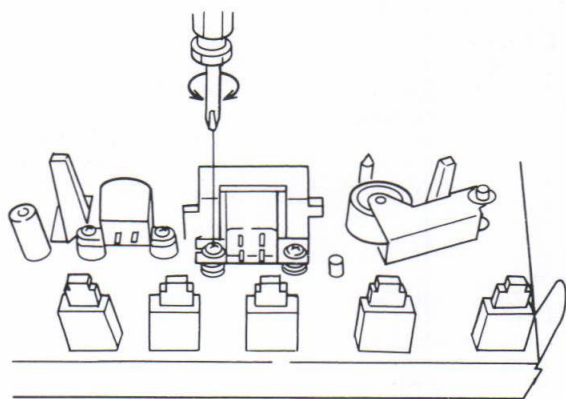

Fig. 11-6 Ajuste azimutal de la cabeza de grabación

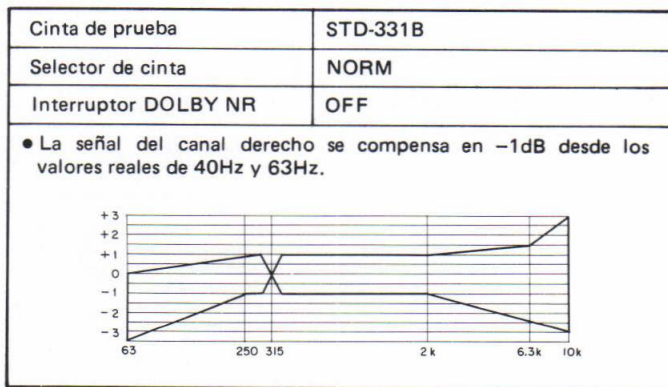

Fig. 11-7 Zona de respuesta de frecuencia de reproducción permisible

- Regular el interruptor DOLBY NR a la posición OFF.

1. Ajuste del acimut de la cabeza.						
• Girar V101 y V201 a la posición máxima (completamente a la derecha).						
	Modo	Señal de entrada y cinta de prueba	Punto de ajuste	Punto de medición	Valor de ajuste	Observaciones
1	Parada (STOP)	Regular el interruptor selector de cinta (TAPE SELECTOR) a la posición NORM.				
2	Reproducción (PLAY)	Reproducir la parte de 10kHz/~20dB de la cinta de prueba STD-331B.	Tornillo de ajuste del acimut de la cabeza. (Ver la Fig. 11-6)	DOL. L (Canal izq.) DOL. R (Canal der.)	Nivel máximo de la señal de reproducción.	
3	Parada (STOP)	Trabar el tornillo con "Screw lock" después del ajuste.				
2. Comprobación del ecualizador de reproducción.						
	Modo	Señal de entrada y cinta de prueba	Punto de ajuste	Punto de medición	Valor de ajuste	Observaciones
1	Parada (STOP)	Regular el interruptor selector de cinta (TAPE SELECTOR) a la posición NORM.				
2	Reproducción (PLAY)	Reproducir las partes de 315Hz/~20dB y 6,3kHz/~20dB de la cinta de prueba STD-331B.	Comprobar	DOL. L (Canal izq.) DOL. R (Canal der.)	El nivel de reproducción de 6,3kHz debe ser de $-0,5 \pm 2$ dB con respecto al nivel de 315Hz.	
3	Parada (STOP)	Regular el interruptor selector de cinta (TAPE SELECTOR) a la posición CrO ₂ o METAL.				
4	Reproducción (PLAY)	Reproducir las partes de 315Hz/~20dB y 6,3kHz/~20dB de la cinta de prueba STD-331B.	Comprobar	DOL. L. (Canal izq.) DOL. R (Canal der.)	El nivel de reproducción de 6,3kHz debe ser de $-4,5 \pm 2$ dB con respecto al nivel de 315Hz.	

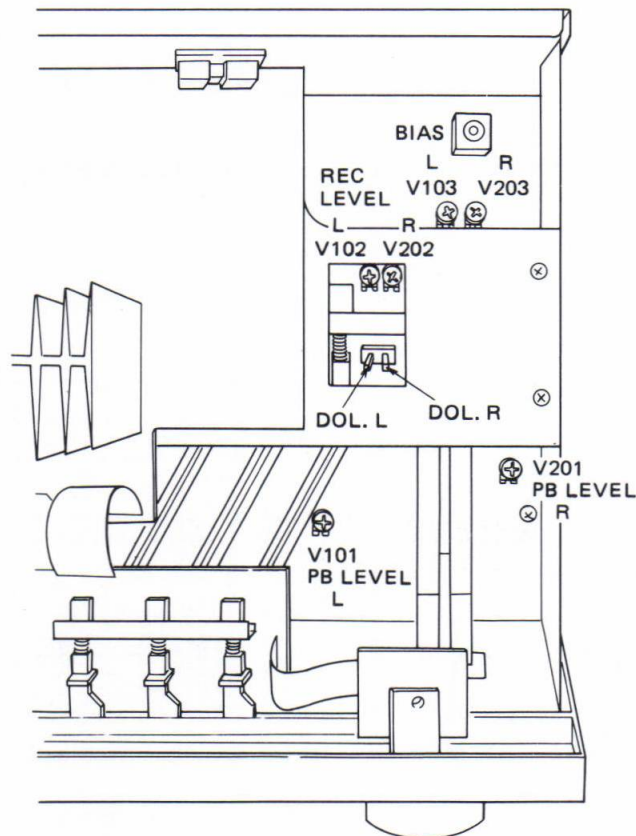

Fig. 11-8 Puntos de ajuste

3. Ajuste del nivel de reproducción							
● Este ajuste determina el nivel DOLBY NR, y debe efectuarse con gran cuidado.							
	Modo	Señal de entrada y cinta de prueba	Punto de ajuste	Punto de medición	Valor de ajuste	Observaciones	
1	Parada (STOP)	Regular el interruptor selector de cinta (TAPE SELECTOR) a la posición NORM.					
2	Reproducción (PLAY)	Reproducir la parte de 315Hz/0dB de la cinta de prueba STD-331B.	V101 (Canal izquierdo) V201 (Canal derecho)	DOL. L (Canal izq.) DOL. R (Canal der.)	-7,7dBv (412.1mV)		
4. Ajuste de la respuesta de frecuencia de grabación y reproducción.							
	Modo	Señal de entrada y cinta de prueba	Punto de ajuste	Punto de medición	Valor de ajuste	Observaciones	
1	Parada (STOP)	Regular el interruptor selector de cinta (TAPE SELECTOR) a la posición NORM. Regular el interruptor de función (FUNCTION) a la posición TUNER.					
2	Pausa en grabación (REC-PAUSE)	Aplicar una señal de 315Hz/-30dBv (31,6mV) a los terminales TUNER INPUT.	Comprobar	DOL. L (Canal izq.) DOL. R (Canal der.)	Aprox. -27,7dBv (41,2mV)		
3	Grabación/reproducción (REC/PLAY)	Grabar la señal en la cinta de prueba STD-608A a 315Hz y 6,3kHz, y reproducir luego esta parte de la cinta.	V103 (Canal izquierdo) V203 (Canal derecho)	DOL. L (Canal izq.) DOL. R (Canal der.)	Ajustar el nivel de reproducción de 6,3kHz a $0_{-0,5}^{+1}$ dB mayor al nivel de 315Hz.		
4		Grabar y reproducir las señales de hasta 12kHz en la cinta de prueba STD-608A, y comprobar que las señales están de acuerdo con la zona de respuesta de frecuencia permisible mostrada en la Fig. 11-9.					
5		Regular el interruptor DOLBY NR a la posición ON. Grabar y reproducir las señales de hasta 10kHz en la cinta de prueba STD-608A, y comprobar que estas señales están de acuerdo con la zona de respuesta de frecuencia permisible mostrada en la Fig. 11-9.					
6		Regular el interruptor selector de cinta (TAPE SELECTOR) a la posición CrO ₂ . Grabar y reproducir las señales de hasta 12kHz en la cinta de prueba STD-603, y comprobar que estas señales están de acuerdo con la zona de respuesta de frecuencia permisible mostrada en la Fig. 11-10 (para ON y OFF de DOLBY NR).					
7		Regular el interruptor selector de cinta (TAPE SELECTOR) a la posición METAL. Grabe y reproduzca las señales de hasta 12kHz en la cinta de prueba STD-610, y comprobar que estas señales están de acuerdo con la zona de respuesta de frecuencia permisible mostrada en la Fig. 11-11 (para ON y OFF de DOLBY NR).					
5. Ajuste del nivel de grabación.							
	Modo	Señal de entrada y cinta de prueba	Punto de ajuste	Punto de medición	Valor de ajuste	Observaciones	
1	Parada (STOP)	Regular el interruptor selector de cinta (TAPE SELECTOR) a la posición NORM. Regular el interruptor de función (FUNCTION) a la posición TUNER.					
2	Pausa en grabación (REC-PAUSE)	Aplicar una señal de 315Hz a los terminales TUNER INPUT.	Cambiar el nivel de señal de entrada.	DOL. L (Canal izq.) DOL. R (Canal der.)	-7,7dBv (412mV)	El nivel de señal de entrada es de aprox. -10dBv.	
3		Regular el interruptor DOLBY NR a la posición ON.					
4	Grabación/reproducción (REC/PLAY)	Grabar las señales en la cinta de prueba STD-608A, y reproducir luego esta parte de la cinta.	V102 (Canal izquierdo) V202 (Canal derecho)	DOL. L (Canal izq.) DOL. R (Canal der.)	-7,7dBv (412,1mV)		
5		Regular el interruptor selector de cinta (TAPE SELECTOR) a la posición CrO ₂ .					
6		Grabar las señales en la cinta de prueba STD-603, y reproducir luego esta parte de la cinta.	Comprobar	DOL. L (Canal izq.) DOL. R (Canal der.)	-7,7dBv±1,5dB		
7		Regular el interruptor selector de cinta (TAPE SELECTOR) a la posición METAL.					
8		Grabar las señales en la cinta de prueba STD-610, y reproducir luego esta parte de la cinta.	Comprobar	DOL. L (Canal izq.) DOL. R (Canal der.)	-7,7dBv±1,5dB		
6. Comprobación del efecto del limitador.							
	Modo	Señal de entrada y cinta de prueba	Punto de ajuste	Punto de medición	Valor de ajuste	Observaciones	
1	Parada (STOP)	Regular el interruptor selector de cinta (TAPE SELECTOR) a la posición NORM. Regular el interruptor de función (FUNCTION) a la posición TUNER.					
2	Pausa en grabación (REC-PAUSE)	Aplicar una señal de 1kHz a los terminales TUNER INPUT.	Cambiar el nivel de señal de entrada.	DOL. L (Canal izq.) DOL. R (Canal der.)	-7,7dBv (412,1mV)	El nivel de señal de entrada es de aprox. -10dBv.	
3		Aumentar el nivel de señal de entrada a +10dB mayor al nivel indicado en el procedimiento 2.	Comprobar	DOL. L (Canal izq.) DOL. R (Canal der.)	-2,3dBv±1,5dB	El nivel de señal de entrada es de aprox. 0dBv.	

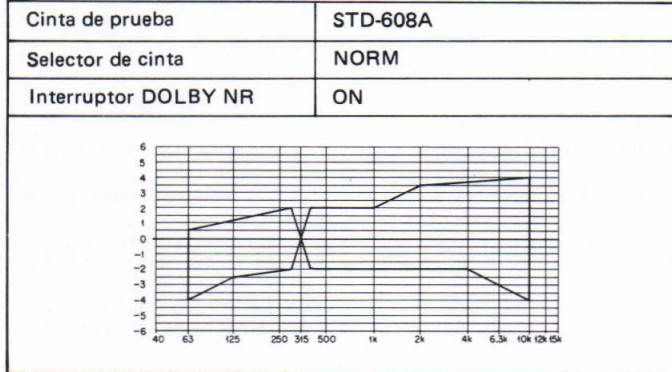
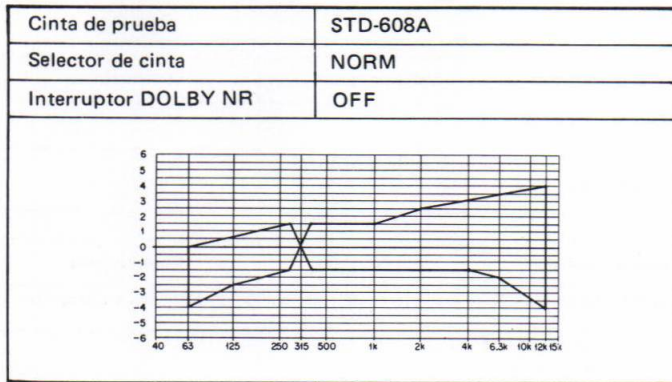

Fig. 11-9 Zona de respuesta de frecuencia de grabación y reproducción permisible (NORM)

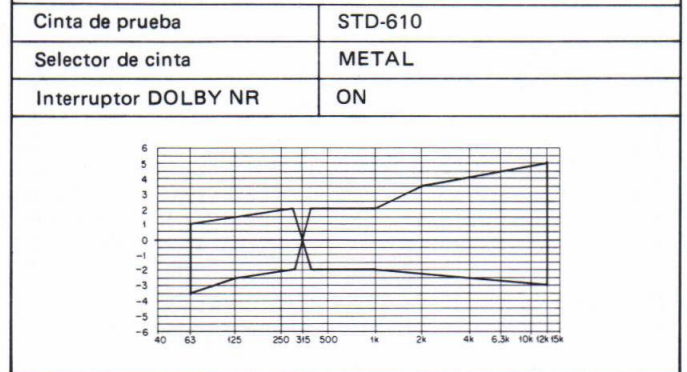
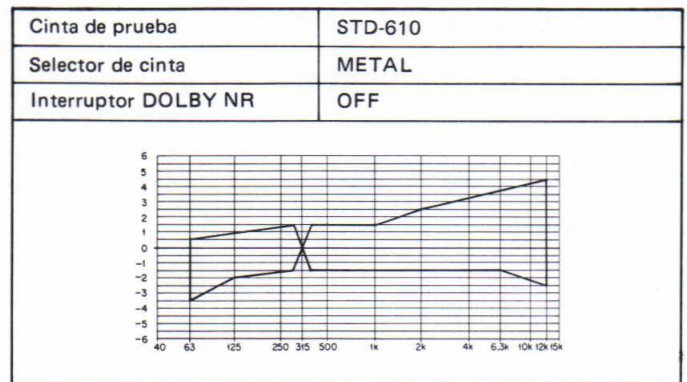

Fig. 11-11 Zona de respuesta de frecuencia de grabación y reproducción permisible (METAL)

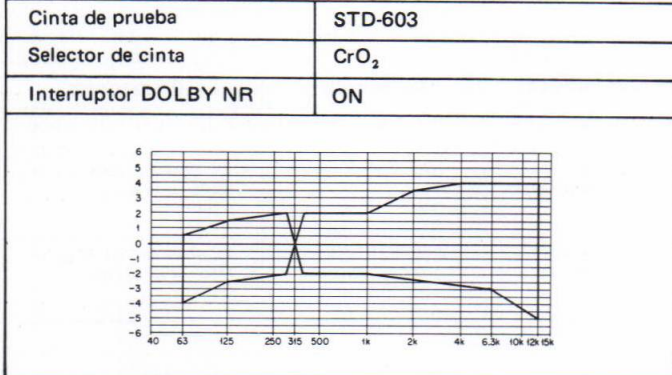
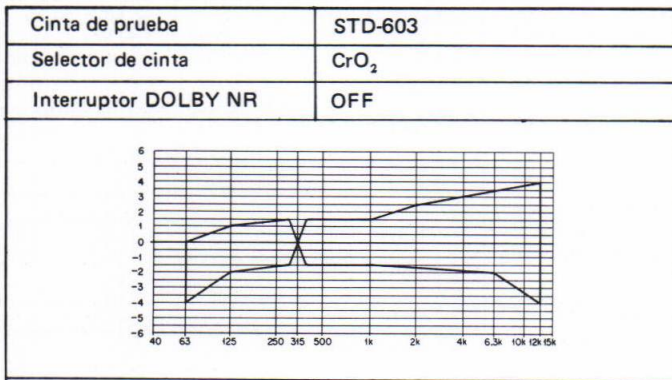
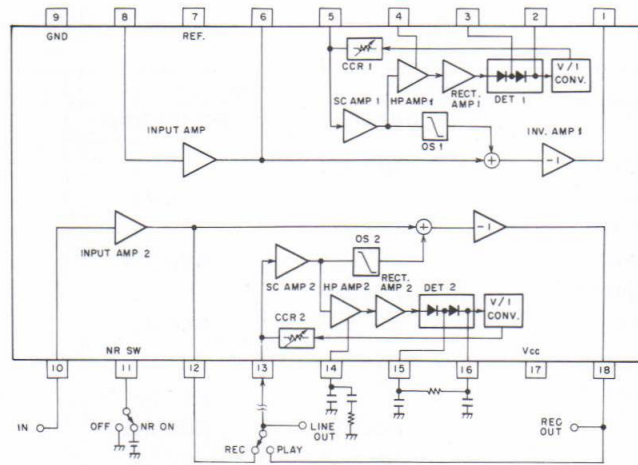

Fig. 11-10 Zona de respuesta de frecuencia de grabación y reproducción permisible (CrO₂)

12. IC DATA (HA12045)

Block Diagram



Pin Description

Pin No.	I/O	Name	Description
1	Output	REC OUT 1	Inv. amp. output.
2	—	DET1-2	Detector filter.
3	—	DET1-1	Detector filter.
4	—	HPF1	Filter network (2).
5	Input	VCR1	Side chain amp. input (2).
6	Output	MONI. OUT	Input amp. output (2).
7	Output	REF	Reference voltage output.
8	Input	INPUT 1	Audio input (2).
9	—	GND	Ground.
10	Input	INPUT 2	Audio input (1).
11	Input	NR SW	Noise reduction switch (High active).
12	Output	MONI. OUT	Input amp. output (1)
13	Input	VCR2	Side chain amp. input (1).
14	—	HPF2	Filter network (1).
15	—	DET2-1	Detector filter.
16	—	DET2-2	Detector filter.
17	—	Vcc	DC power.
18	Output	REC OUT 2	Inv. amp. output.

13. SUPPLEMENT FOR KU TYPE

Model DC-101Z/KU (U.S.A. model) is the same as the DC-100/HE with the exception of this supplement.

Contrast of Miscellaneous Parts

ELECTRICAL COMPONENTS

Mark	Symbol & Description	Part No.		Remarks
		DC-100Z/HE	DC-101Z/KU	
⚠★★	FU501, FU601 Fuse (T2.0A) Fuse (2A)	REK-086	
		REK-081	
⚠★★	FU701 Fuse (T1.6A) Fuse (1.6A)	REK-069	
		REK-074	
⚠★★	FU801 Fuse (T800mA) Fuse (2A)	REK-064	
		REK-081	
⚠★	T1 Power transformer (220/240V) Power transformer (120V)	RTT-390	
		RTT-391	
⚠	AC power cord	RDG-027	RDG-048	for AC power cord
⚠	Strain relief	REC-396	REC-395	

P.C. BOARD ASSEMBLIES

Mark	Symbol & Description	Part No.		Remarks
		DC-100Z/HE	DC-101Z/KU	
	Power assembly	Non supply	Non supply	Fuses, R740
	Power switch assembly	Non supply	Non supply	R801, C801

OTHERS

Mark	Symbol & Description	Part No.		Remarks
		DC-100Z/HE	DC-101Z/KU	
	Front panel	RNT-040	RNT-043	English/German/French/Italian English
	Door assembly	RXX-451	RXX-454	
	Operating instructions	RRE-064	
	Operating instructions	RRB-237	
	Packing case	RHG-736	RHG-753	

● Power Assembly for KU Type

Power assembly for KU type is the same as the power assembly for HE type with the exception of following sections.

Symbol & Description	HE type	KU type
R740 Carbon film resistor	RD½PM 1R8J

● Power Switch Assembly for KU Type

Power switch assembly for KU type is the same as the power switch assembly for HE type with the exception of following sections.

Symbol & Description	HE type	KU type
⚠ C801 Ceramic capacitor	RCG-009	RCG-006
⚠ R801 Carbon film resistor	RD½PM 225J

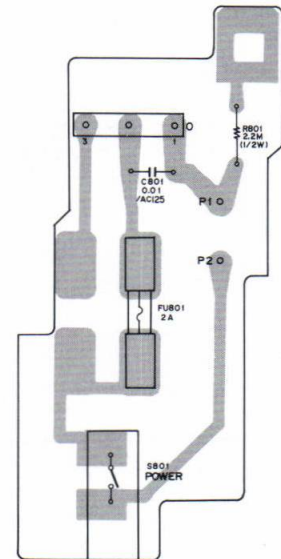

Power Supply Circuit for KU Type

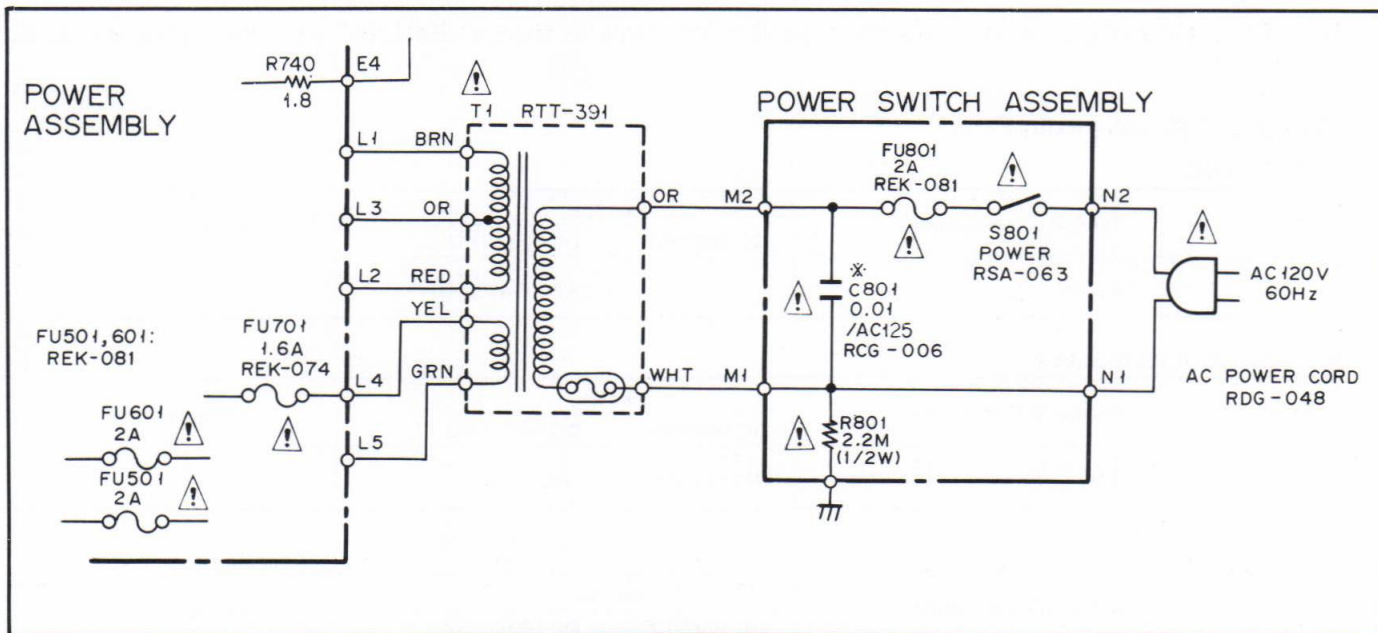

Safety Information

1. SAFETY PRECAUTIONS

The following check should be performed for the continued protection of the customer and service technician.

LEAKAGE CURRENT CHECK

Measure leakage current to a known earth ground (water pipe, conduit, etc.) by connecting a leakage current tester such as Simpson Model 229-2 or equivalent between the earth ground and all exposed metal parts of the appliance (input/output terminals, screwheads, metal overlays, control shaft, etc.). Plug the AC line cord of the appliance directly into a 120V AC 60Hz outlet and turn the AC power switch on. Any current measured must not exceed 0.5mA.

ANY MEASUREMENTS NOT WITHIN THE LIMITS OUTLINED ABOVE ARE INDICATIVE OF A POTENTIAL SHOCK HAZARD AND MUST BE CORRECTED BEFORE RETURNING THE APPLIANCE TO THE CUSTOMER.

2. PRODUCT SAFETY NOTICE

Many electrical and mechanical parts in the appliance have special safety related characteristics. These are often not evident from visual inspection nor the protection afforded by them necessarily can be obtained by using replacement components rated for voltage, wattage, etc. Replacement parts which have these special safety characteristics are identified in this Service Manual.

Electrical components having such features are identified by marking with a Δ on the schematics and on the parts list in this Service Manual.

The use of a substitute replacement component which does not have the same safety characteristics as the PIONEER recommended replacement one, shown in the parts list in this Service Manual, may create shock, fire, or other hazards.

Product Safety is continuously under review and new instructions are issued from time to time. For the latest information, always consult the current PIONEER Service Manual. A subscription to, or additional copies of, PIONEER Service Manual may be obtained at a nominal charge from PIONEER.

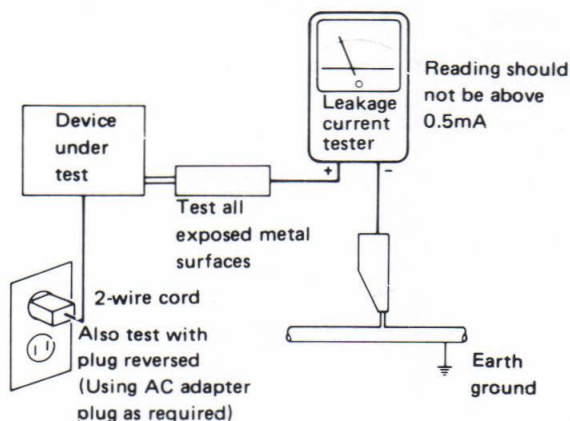

AC Leakage Test

14. SUPPLEMENT FOR HEZ TYPE

Model DC-100Z/HEZ (West Germany model) is the same as the DC-200Z/HE with the exception of this supplement.

Contrast of Miscellaneous Parts

CAPACITORS

Mark	Symbol & Description	Part No.		Remarks
		DC-100Z/HE	DC-100Z/HEZ	
	C2, C3 Ceramic	CKDYF 473Z 50	

P.C. BOARD ASSEMBLIES

Mark	Symbol & Description	Part No.		Remarks
		DC-100Z/HE	DC-100Z/HEZ	
	Power assembly	Non supply	Non supply	

OTHERS

Mark	Symbol & Description	Part No.		Remarks
		DC-100Z/HE	DC-100Z/HEZ	
	Operating instructions (German)	RRD-067	
	Operating instructions (English/German/French/Italian)	RRE-064	
	Packing case	RHG-736	RHG-736	

● Power Assembly for HEZ Type

Power assembly for HEZ type is the same as the power assembly for HE type with the exception of following sections.

Symbol & Description	HE type	HEZ type
L502, L602 AF choke coil	RTH-004
C501, C511, C601, C611	CKPYB 391K 50
C503, C603	CKPYB 221K 50	CKPYB 391K 50
C504, C604	CCPSL 101J 50	CKPYB 221K 50
C513, C613	CKDYX 473M 25
⚠ R510, R610	RD¼LF 100J
R508, R608	RD1/6PM 511J	RD1/6PM 102J
C701, C702	CKDYF 223Z 50	CKDYX 473M 25
R501, R601	RD1/6PM 511J	RD1/6PM 222J
R503, R603	RD1/6PM 511J

Schematic Diagram for HEZ Type

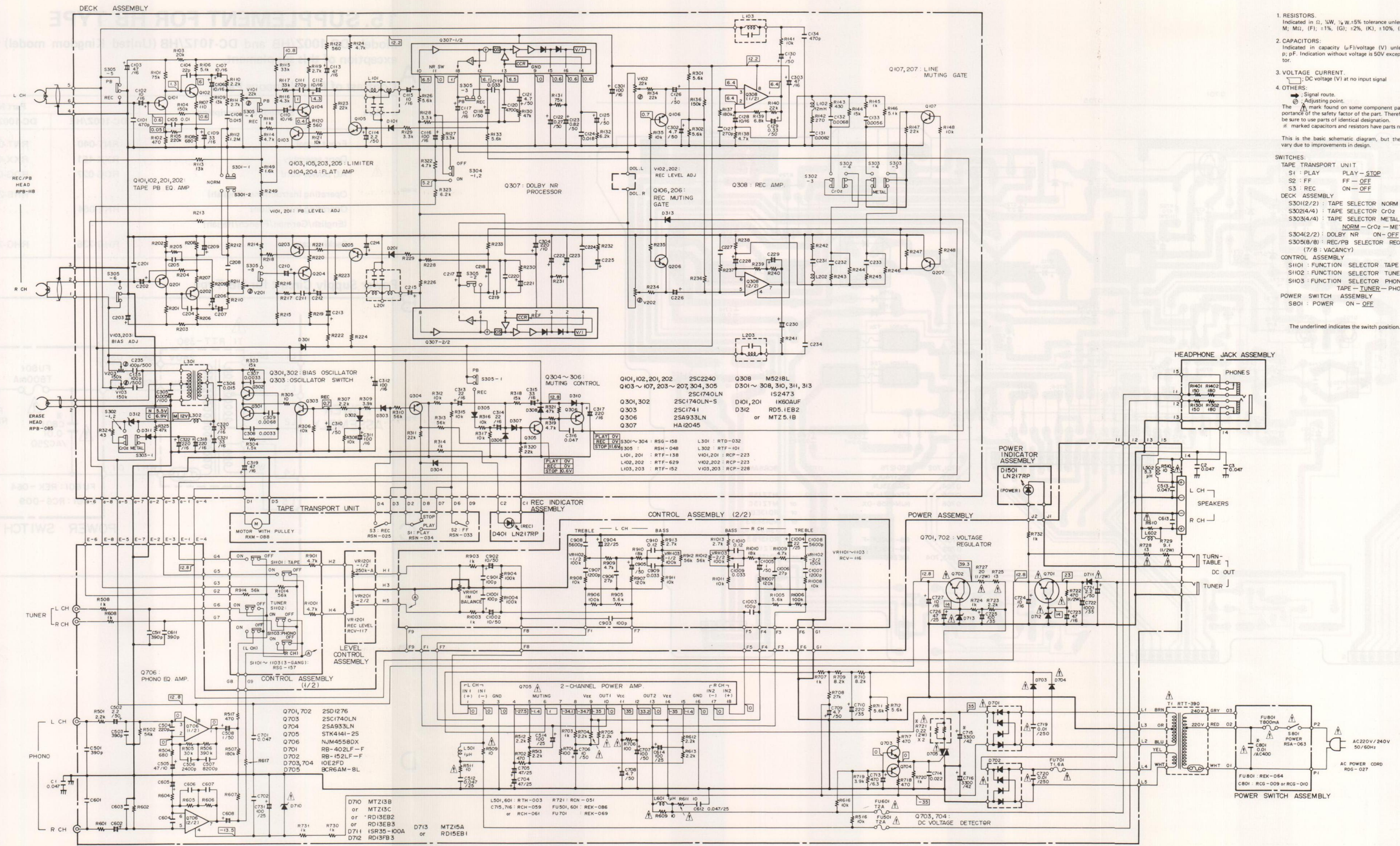

- RESISTORS:**
Indicated in Ω, kΩ, MΩ, W, ±5% tolerance unless otherwise noted; k, kt, M, Mt, (F), ±1%, (G), ±2%, (K), ±10%, (M), ±20% tolerance
 - CAPACITORS:**
Indicated in capacity (μF)/voltage (V) unless otherwise noted; p, pF. Indicated without voltage is 50V except electrolytic capacitor.
 - VOLTAGE CURRENT:**
Indicated in V at no input signal
 - OTHERS:**
● Signal route
⊗ Adjusting point
The ⊗ mark found on some component parts indicates the importance of the safety factor of the part. Therefore, when replacing, be sure to use parts of identical designation.
⊗ marked capacitors and resistors have parts numbers.
This is the basic schematic diagram, but the actual circuit may vary due to improvements in design.
- SWITCHES:**
- TAPE TRANSPORT UNIT
 S1 PLAY PLAY - STOP
 S2 FF FF - OFF
 S3 REC ON - OFF
- DECK ASSEMBLY
 S301(2/2) TAPE SELECTOR NORM
 S302(4/4) TAPE SELECTOR CrO2
 S303(4/4) TAPE SELECTOR METAL
 NORM - CrO2 - METAL
 S304(2/2) DOLBY NR ON - OFF
 S305(8/8) REC/PB SELECTOR RECORDING - PLAYBACK
 (7/8: VACANCY)
- CONTROL ASSEMBLY
 S101 FUNCTION SELECTOR TAPE
 S102 FUNCTION SELECTOR TUNER
 S103 FUNCTION SELECTOR PHONO
 TAPE - TUNER - PHONO
- POWER SWITCH ASSEMBLY
 S801 POWER ON - OFF
- The underlined indicates the switch position.

15. SUPPLEMENT FOR HB TYPE

Models DC-100Z/HB and DC-101Z/HB (United Kingdom model) are the same as the DC-100Z/HE with the exception of this supplement.

Contrast of Miscellaneous Parts

Mark	Symbol & Description	Part No.			Remarks
		DC-100Z/HE	DC-100Z/HB	DC-101Z/HB	
	Front panel	RNT-040	RNT-040	RNT-043	
	Door assembly	RXX-451	RXX-451	RXX-454	
	AC power cord	RDG-027	RDG-032	RDG-032	
	Operating instructions (English)	RRB-237	RRB-237	
	Operating instructions (English/German/French/Italian)	RRE-064	
	Packing case	RHG-736	RHG-736	RHG-752	

Power Supply Circuit for HB Type

