

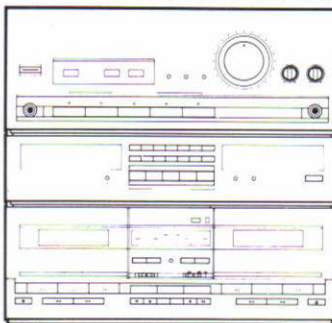

Service Manual



ORDER NO.
ARP1907

STEREO DOUBLE CASSETTE DECK AMPLIFIER

DC-Z93

Free service manuals
Gratis schema's

Digitized by

www.freesevicemanuals.info

DC-Z93 HAS FOLLOWING VERSIONS:

Type	Power requirement	Export destination
HB	AC220V, 240V (switchable) *	United Kingdom
HE	AC220V, 240V (switchable) *	European continent
HEWZ	AC220V, 240V (switchable) *	West Germany
KUC	AC120V only	U.S.A. and Canada
YP	AC240V only	Australia
SD	AC110V, 120V-127V, 220V, 240V (switchable)	Kingdom of Saudi Arabia and General market

*: Change the Jumper wires of assembly boards.

- This manual is applicable to the HB and HE type.
- As to the system composition, refer to the S-333 service manual (ARP1935).
- As to the HE type, refer to page 74.
- As to the other types, refer to applicable service manuals.
- Ce manuel pour le service comprend les explications de réglage en français.
- Este manual de servicio trata del método ajuste escrito en español.

CONTENTS

1. SAFETY INFORMATION	2	6. ADJUSTMENTS	56
2. SPECIFICATIONS	3	6. RÉGLAGE	61
3. EXPLODED VIEWS, PACKING AND PARTS LIST	4	6. AJUSTE	66
4. SCHEMATIC DIAGRAMS AND P.C. BOARD CONNECTION DIAGRAMS	14	7. IC INFORMATION	71
5. P.C.B.'s PARTS LIST	49	8. FOR HE TYPE	74
		9. PANEL FACILITIES	75
		10. CONNECTIONS	80

PIONEER ELECTRONIC CORPORATION 4-1, Meguro 1-Chome, Meguro-ku, Tokyo 153, Japan

PIONEER ELECTRONICS SERVICE INC. P.O. Box 1760, Long Beach, California 90801 U.S.A.

PIONEER ELECTRONICS OF CANADA, INC. 505 Cochrane Drive, Markham, Ontario L3R 8E3 Canada

PIONEER ELECTRONIC [EUROPE] N.V. Keetberglaan 1, 2740 Beveren, Belgium

PIONEER ELECTRONICS AUSTRALIA PTY. LTD. 178-184 Boundary Road, Braeside, Victoria 3195, Australia TEL: [03] 580-9911

© **PIONEER ELECTRONIC CORPORATION** 1990

YV JAN. 1990 Printed in Japan.

1. SAFETY INFORMATION

1. SAFETY PRECAUTIONS

The following check should be performed for the continued protection of the customer and service technician.

LEAKAGE CURRENT CHECK

Measure leakage current to a known earth ground (water pipe, conduit, etc.) by connecting a leakage current tester such as Simpson Model 229-2 or equivalent between the earth ground and all exposed metal parts of the appliance (input/output terminals, screwheads, metal overlays, control shaft, etc.). Plug the AC line cord of the appliance directly into a 120V AC 60Hz outlet and turn the AC power switch on. Any current measured must not exceed 0.5mA.

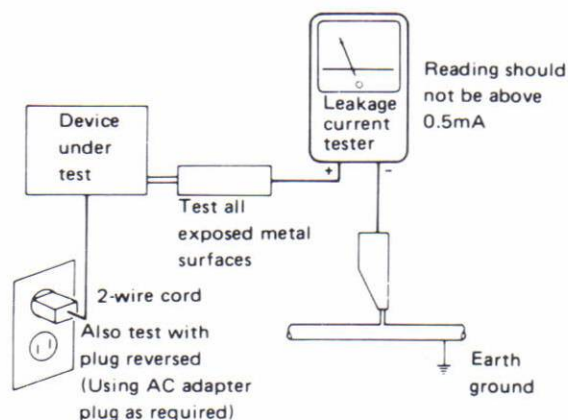

AC Leakage Test

ANY MEASUREMENTS NOT WITHIN THE LIMITS OUTLINED ABOVE ARE INDICATIVE OF A POTENTIAL SHOCK HAZARD AND MUST BE CORRECTED BEFORE RETURNING THE APPLIANCE TO THE CUSTOMER.

2. PRODUCT SAFETY NOTICE

Many electrical and mechanical parts in the appliance have special safety related characteristics. These are often not evident from visual inspection nor the protection afforded by them necessarily can be obtained by using replacement components rated for voltage, wattage, etc. Replacement parts which have these special safety characteristics are identified in this Service Manual.

Electrical components having such features are identified by marking with a $\underline{\Delta}$ on the schematics and on the parts list in this Service Manual.

The use of a substitute replacement component which does not have the same safety characteristics as the PIONEER recommended replacement one, shown in the parts list in this Service Manual, may create shock, fire, or other hazards.

Product Safety is continuously under review and new instructions are issued from time to time. For the latest information, always consult the current PIONEER Service Manual. A subscription to, or additional copies of, PIONEER Service Manual may be obtained at a nominal charge from PIONEER.

2. SPECIFICATIONS

Cassette tape deck amplifier: DC-293

Amplifier Section

Continuously Average Power Output is 50 Watts* per channel, min., at 8 ohms from 40 Hertz to 20,000 Hertz, with no more than 0.4 % total harmonic distortion.

* Measured pursuant to the Federal Trade Commission's Trade Regulation rules on Power Output Claims for Amplifiers.

Music power	90 W + 90 W (1 kHz, T.H.D. 1 %, 8 Ω)
Music power (DIN)	90 W + 90 W (1 kHz, T.H.D. 1 %, 8 Ω)
Peak music power	500 W (1kHz, 10%, 6Ω)
Continuous Power Output (DIN)	60 W + 60 W (1 kHz, T.H.D. 1 %, 8 Ω)
Graphic equalizer frequency band.....	60 Hz, 150 Hz, 400 Hz, 1 kHz, 2.4 kHz, 6 kHz, 15 kHz, ± 7 dB
Signal-to-Noise Ratio (IHF, short-circuited, A network)	
PHONO	72 dB
Signal-to-Noise Ratio (DIN, continuous Power/50 mW)	
PHONO	68 dB/60 dB
Total Harmonic Distortion (40 Hz to 20,000 Hz, 30 W, 8 ohms)**	No more than 0.2 %

Tape Deck Section

Systems	4 track, 2-channel stereo
Heads	Recording/playback head x 2 Erasing head x 2
Motor.....	DC servo 2 speed motor x 2
Wow and Flutter.....	No more than 0.09 % (WRMS)
Fast Winding Time	Approximately 95 seconds (C-60 tape)
Frequency Response (– 20 dB recording):	
Normal tape	35 Hz to 14,000 Hz ± 6 dB
CrO ₂ tape	35 Hz to 15,000 Hz ± 6 dB
Metal tape	35 Hz to 16,000 Hz ± 6 dB
Signal-to-Noise ratio	
Dolby NR OFF.....	56 dB (EIAJ)
Noise Reduction Effect	
Dolby B type NR ON	More than 10 dB (at 5 kHz)
Dolby C type NR ON	More than 17 dB (at 5 kHz)

Furnished Parts

Operating Instructions	1
Remote control unit	1
Dry cell batteries	2

Miscellaneous

Power requirements	
U.K. and Australian models.....	a.c. 240 Volts~, 50/60 Hz
Other destination models	
.....	AC 110/120–127/220/240 V (switchable) 50/60 Hz
Power Consumption	426 W
Dimensions	360 (W) x 356 (H) x 329 (D) mm 14-3/16 (W) x 14 (H) x 12-15/16 (D) in
Weight (without package)	10.5 kg (23 lb 2 oz)

Accessories

EP Adaptor.....	1
-----------------	---

• Specifications and design subject to possible modification without notice due to improvement.

** Measured By Audio Spectrum Analyzer.

3. EXPLODED VIEWS, PACKING AND PARTS LIST

3.1 EXTERIOR AND PACKING

Partslist of Exterior and Packing

NOTES:

- Parts without part number cannot be supplied.
- The \triangle mark found on some component parts indicates the importance of the safety factor of the part. Therefore, when replacing, be sure to use parts of identical designation.
- Parts marked by "●" are not always kept in stock. Their delivery time may be longer than usual or they may be unavailable.

Mark	No.	Description	Parts No.	Mark	No.	Description	Parts No.
	1	KNOB (VOLUME)	AAB1135		41	NYLON BINDER	
	2	KNOB	AAB1136	\triangle	42	STRAIN RELIEF	AEC-882
	3	BUTTON (ASES)	AAD1669		43	NYLON REVET	
	4	BUTTON (POWER)	AAD1674		44	LEG ASSEMBLY	AEC1222
	5	BUTTON (GOLD)	AAD1682		45	CLAMPER	
	6	BUTTON (FUNCTION)	AAD1711		46	"AAA" DRY CELL	
	7	BUTTON (GEQ)	AAD1712		47	FRONT PAD (L,R)	AHA1298
	8	BUTTON (EQUALIZER)	AAD1713		48	REAR PAD (L,R)	AHA1299
	9	BUTTON (REC)	AAD1714		49	PACKING CASE	AHD1792
	10	BUTTON (EJECT)	AAD1716		50	LITERATURE BAG	
	11	BUTTON (COPY)	AAD1717		51	SHEET	AHG1149
	12	BUTTON (PLAY)	AAD1718		52	TERMINAL SCREW	
	13	SLIDE KNOB	AAE1128		53	FRONT PANEL	AMB1637
	14	DISPLAY LENS (POWER)	AAK1800		54	PLATE	
	15	DECK ACCESSORY PANEL (U)	AAK1808		56	EJECT LEVER (L)	AMR2031
	16	INDICATOR LENS	AAK1846		57	EJECT LEVER (R)	AMR2032
	17	GEQ ACCESSORY PANEL (L)	AAK1923		58	CHASSIS	
	18	GEQ ACCESSORY PANEL (R)	AAK1924		59	REAR PANEL	
	19	DOOR ACCESSORY PANEL (L)	AAK1872		60	BONNET	ANE1224
	20	DOOR ACCESSORY PANEL (R)	AAK1873		61	PLATE	
	21	AMP ACCESSORY PANEL (D)	AAK1874		62	PLATE (B)	
	22	AMP ACCESSORY PANEL (U)	AAK1875		63	PLATE	
	23	DECK ACCESSORY PANEL (D)	AAK1876		64	PLATE	
	24	BATTERY COVER	AZN1846		65	PLATE (A)	
	25	CASSETTE DOOR (L)	AAN1177		66	PLATE	
	26	CASSETTE DOOR (R)	AAN1178		67	HEAT SINK	
	27	COUNTER	AAW1009		68	SHIELD PLATE	
	28	...			69	OPERATING INSTRUCTIONS	ARB1218
	29	LABEL (PAPER)	AAX1301		70
	30	SCREW	ABA1084		71
	31	SCREW (STEEL)	ABA1095		72	SPEANA ASSEMBLY	AWG1025
	32	WASHER (PAPER)			73	FUNCTION ASSEMBLY	AWK1174
	33	SPRING 1	ABH1062		74	AF ASSEMBLY	AWZ2630
	34	SPRING 2	ABH1063		75	GEQ ASSEMBLY	AWG1034
	35	KEEP PLATE	ABK1011		76	REC ASSEMBLY	AWK1242
	36	EARTH LEAD			77	DOLBY C ASSEMBLY	AWK1243
	37	EARTH LEAD			78	MAIN VR ASSEMBLY	
\triangle	38	AC POWER CORD	ADG1052		79	HEAD PHONE ASSEMBLY	
	39	COUNTER BELT	AEB1110		80	TRANS CONNECT ASSEMBLY	
	40	SPACER			81	BALANCE ASSEMBLY	
					82	MIC ASSEMBLY	
					83	DECK-1 SW ASSEMBLY	
					84	DECK-2 SW ASSEMBLY	
					85	DECK CENTER ASSEMBLY	AWZ2644
					86	DECK CTRL ASSEMBLY	AWZ2645

Mark No.	Description	Parts No.	Mark No.	Description	Parts No.
87	AMP, GEQ CTRL ASSEMBLY	AWZ2646	97	SCREW	BBZ30P180FMC
88	POWER SUPPLY ASSEMBLY	AWZ2241	98	SCREW	BPZ26P080FMC
89	CONNECT ASSEMBLY		99	NUT	NK90FUC
90	MECHA UNIT (2)	AWY1054	100	SCREW	VPZ30P080FZK
91	MECHA UNIT (1)	AWY1056	101	FU2001 FUSE (T2A)	AEK-511
92	DAMPER ASSEMBLY	AXA1008	102	FU2003 FUSE (T1.6A)	AEK-510
93	REMOTE CONTROL UNIT	AXD1132	103	FU2004 FUSE (T1.25A)	AEK-509
94	SCREW	BBZ30P060FMC	104	FU2005 FUSE (T1.25A)	AEK-509
95	SCREW	BBZ30P080FCU	105	T2001 POWER TRANSFORMER	ATS1254
96	SCREW	BBZ30P080FZK	106	P.C.B SPRING	ABH1055
			107	SCREW	BBZ30P100FZK
			108	SCREW	VPZ30P080FMC

Packing

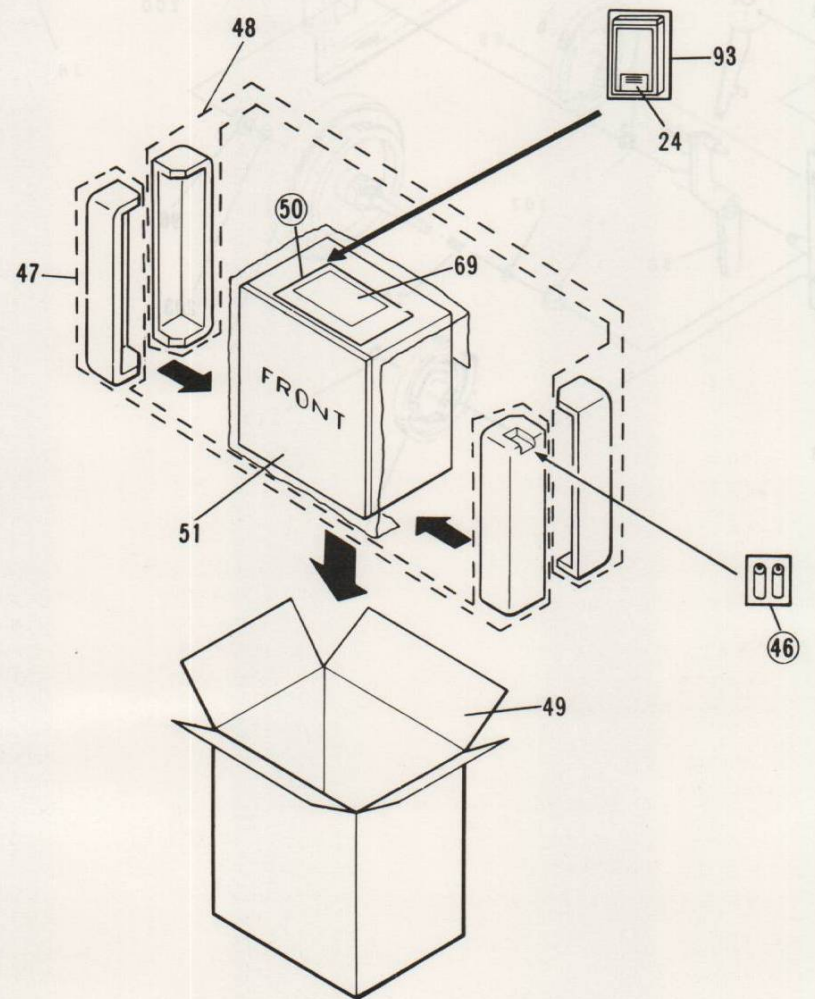

Exterior

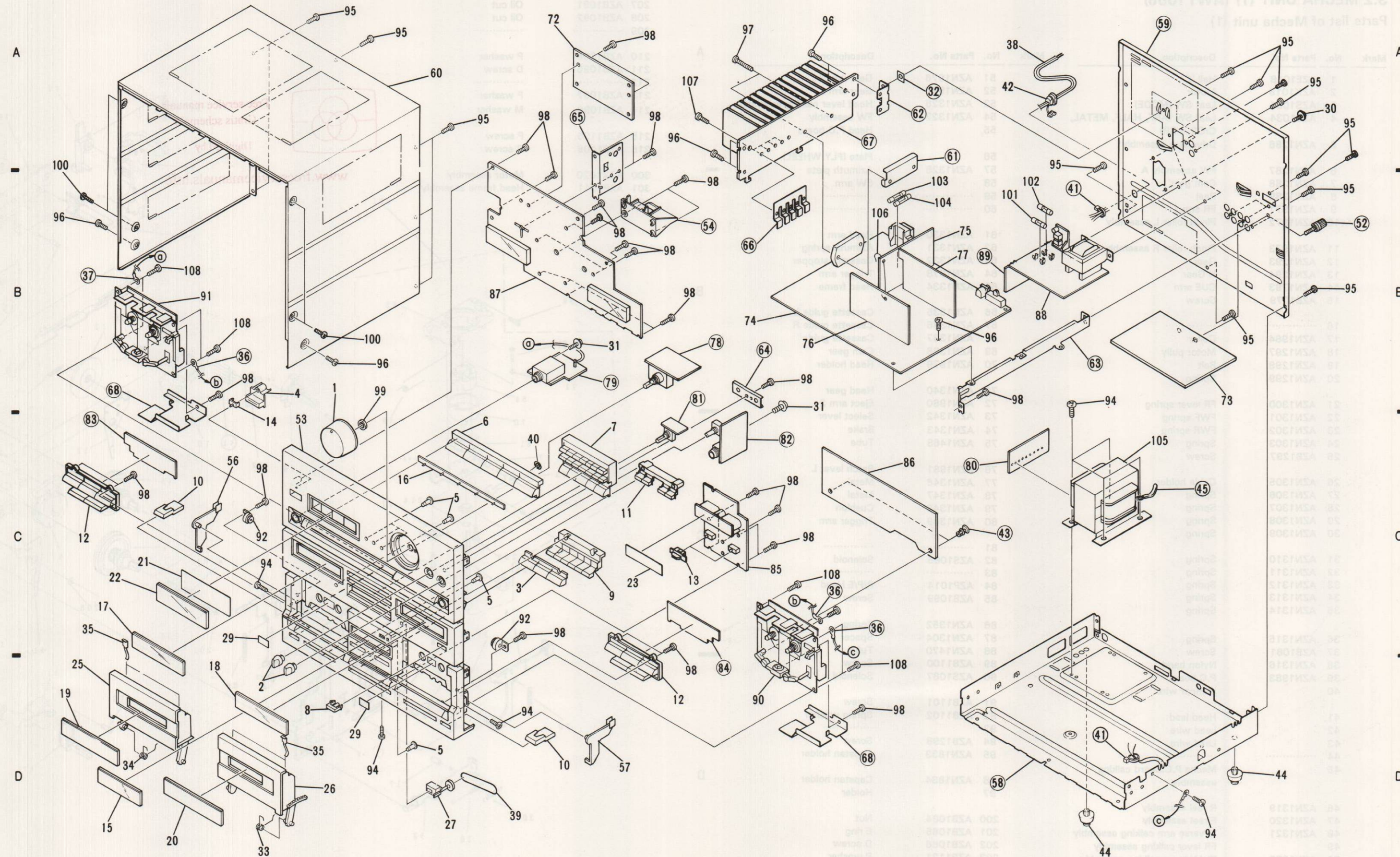

3.2 MECHA UNIT (1) (AWY1056)

Parts list of Mecha unit (1)

Mark	No.	Parts No.	Description	Mark	No.	Parts No.	Description
1	AZE1018		Hall IC	51	AZN1976		Gear arm R
2	AZX1019		Motor	52	AZN1977		Gear arm L
3	AZS1054		Leaf SW (MODE)	53	AZN1326		Head lever calking assembly
4	AZS1034		Leaf SW (ARF, HALF, METAL, CrO2, ARR)	54	AZN1327		FW assembly
5	AZN1286		Drive arm assembly	55			Head P.C.board
6	AZN1287		FW assembly A	56			Plate (FLY WHEEL)
7	AZN1288		Cam gear	57	AZN1328		Azimuth plate
8	AZN1289		Reel	58			SW arm
9	AZN1971		FR arm	59			
10	AZN1972		Pinch roller L assembly	60			
11	AZN1973		Pinch roller R assembly	61	AZN1330		Head arm
12	AZN1293		Gear	62	AZN1331		Azimuth spring
13	AZN1294		H Gear	63	AZN1332		Cassette stopper
14	AZN1793		CUE arm	64	AZN1978		Trigger arm
15	AZB1079		Screw	65	AZN1334		Head frame
16				66	AZN1335		Cassette guide L
17	AZN1984		Collar	67	AZN1336		Cassette guide R
18	AZN1297		Motor pully	68	AZN1337		Cassette guide
19	AZN1298		Belt	69	AZN1338		Cam gear
20	AZN1299		Spring	70	AZN1979		Head holder
21	AZN1300		FR lever spring	71	AZN1340		Head gear
22	AZN1301		FWF spring	72	AZN1980		Eject arm 2
23	AZN1302		FWR spring	73	AZN1342		Select lever
24	AZN1303		Spring	74	AZN1343		Brake
25	AZB1297		Screw	75	AZN1468		Tube
26	AZN1305		Cable holder	76	AZN1981		Ratch lever L
27	AZN1306		Spring	77	AZN1346		Metal
28	AZN1307		Spring	78	AZN1347		Metal
29	AZN1308		Spring	79	AZN1348		Cushion
30	AZN1309		Spring	80	AZN1349		Trigger arm
31	AZN1310		Spring	81			
32	AZN1311		Spring	82	AZS1085		Solenoid
33	AZN1312		Spring	83			
34	AZN1313		Spring	84	AZP1014		R/P/E Head
35	AZN1314		Spring	85	AZB1099		Screw
36	AZN1315		Spring	86	AZN1352		Spring
37	AZB1081		Screw	87	AZN1304		Spacer
38	AZN1316		Nylon band	88	AZN1470		Tube
39	AZN1983		P.C.board	89	AZB1100		Screw
40			Jumper wire	90	AZS1087		Solenoid
41			Head lead	91	AZB1101		Screw
42			Lead wire	92	AZB1102		Spring washer
43			Lead wire	93			
44				94	AZB1298		Screw
45			Mecha P.C.board calking assembly	95	AZN1833		Capstan holder
46	AZN1319		R reel assembly	96	AZN1834		Capstan holder
47	AZN1320		F reel assembly	97			Holder
48	AZN1321		Reverse arm calking assembly	200	AZB1084		Nut
49			FR lever calking assembly	201	AZB1085		E ring
50	AZN1975		PLAY lever calking assembly	202	AZB1086		D screw
				203	AZB1121		P washer
				204	AZB1087		N washer

Mark	No.	Parts No.	Description
	205	AZB1089	U screw
	206	AZB1090	P washer
	207	AZB1091	Oil cut
	208	AZB1092	Oil cut
	209		
A	210	AZB1094	P washer
	211	AZB1095	D screw
	212		
	213	AZB1097	P washer
	214	AZB1098	M washer
	215	AZB1105	P screw
	216	AZB1106	D screw
	300	AZX1020	Motor assembly
	301	AZP1041	Head frame assembly

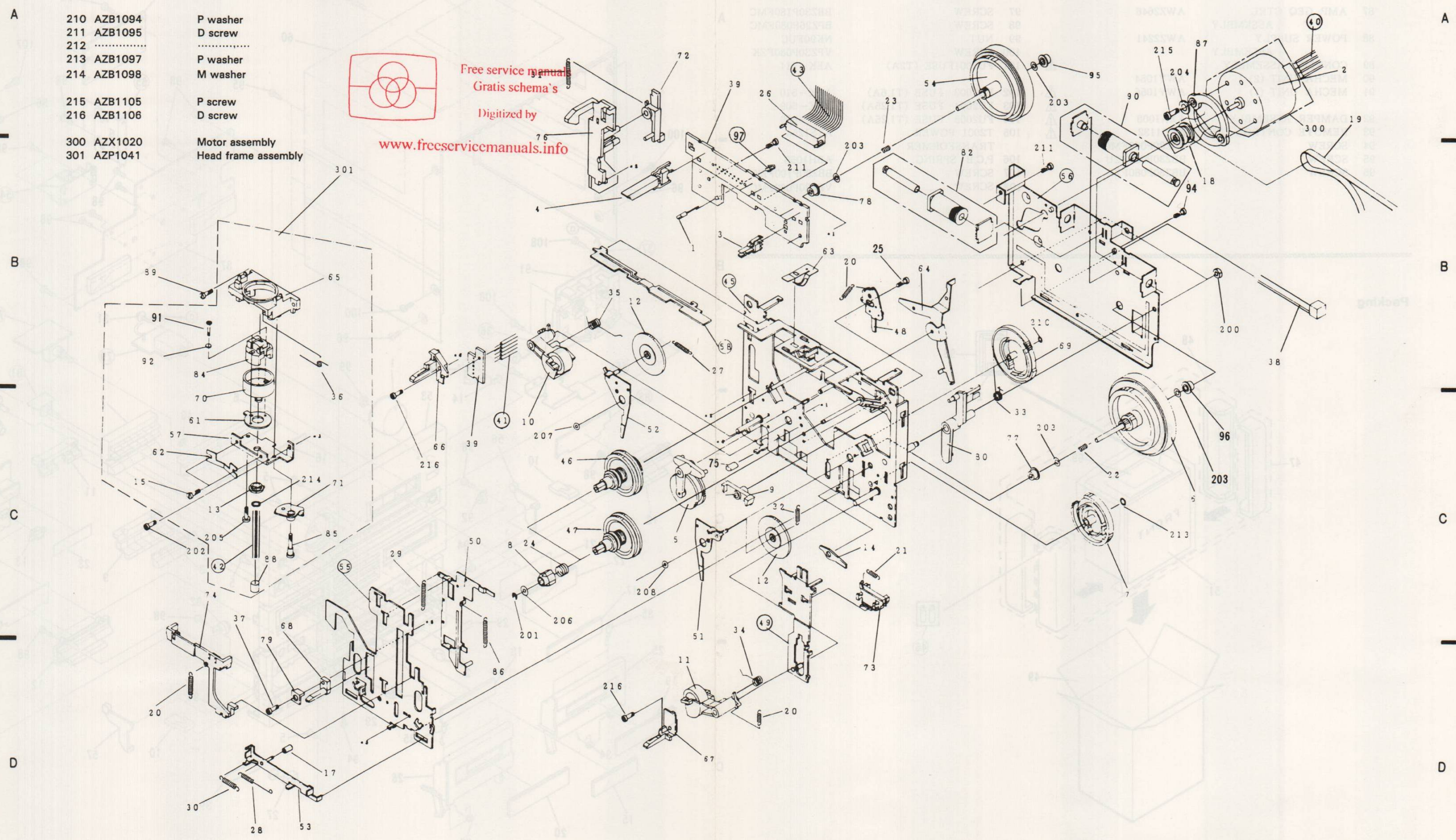

3.3 MECHA UNIT (2) (AWY1054)

Parts list of Mecha unit (2)

Mark	No.	Parts No.	Description	Mark	No.	Parts No.	Description
1	AZE1018		Hall IC	51	AZN1976		Gear arm R
2	AZX1019		Motor	52	AZN1977		Gear arm L
3	AZS1054		Leaf SW (MODE)	53	AZN1326		Head lever calking assembly
4	AZS1034		Leaf SW (ARF, HALF, METAL, CrO2, ARR)	54	AZN1327		FW assembly
5	AZN1286		Drive arm assembly	55			Head P.C.board
6	AZN1287		FW assembly A	56			Plate (FLY WHEEL)
7	AZN1288		Cam gear	57	AZN1328		Azimuth plate
8	AZN1289		Reel	58			SW arm
9	AZN1971		FR arm	59	AZN1988		Eject arm L
10	AZN1972		Pinch roller L assembly	60	AZN1989		Eject arm R
11	AZN1973		Pinch roller R assembly	61	AZN1330		Head arm
12	AZN1293		Gear	62	AZN1331		Azimuth spring
13	AZN1294		H Gear	63	AZN1332		Cassette stopper
14	AZN1793		CUE arm	64	AZN1978		Trigger arm
15	AZB1079		Screw	65	AZN1334		Head frame
16	AZB1080		Screw	66	AZN1335		Cassette guide L
17	AZN1984		Collar	67	AZN1336		Cassette guide R
18	AZN1297		Motor pully	68	AZN1337		Cassette guide
19	AZN1298		Belt	69	AZN1338		Cam gear
20	AZN1299		Spring	70	AZN1979		Head holder
21	AZN1300		FR lever spring	71	AZN1340		Head gear
22	AZN1301		FWF spring	72	AZN1980		Eject arm 2
23	AZN1302		FWR spring	73	AZN1342		Select lever
24	AZN1303		Spring	74	AZN1343		Brake
25	AZB1297		Screw	75	AZN1468		Tube
26	AZN1305		Cable holder	76	AZN1985		Ratch lever R
27	AZN1306		Spring	77	AZN1346		Metal
28	AZN1307		Spring	78	AZN1347		Metal
29	AZN1308		Spring	79	AZN1348		Cushion
30	AZN1309		Spring	80	AZN1349		Trigger arm
31	AZN1310		Spring	81		
32	AZN1311		Spring	82	AZS1085		Solenoid
33	AZN1312		Spring	83		
34	AZN1313		Spring	84	AZP1014		R/P/E Head
35	AZN1314		Spring	85	AZB1099		Screw
36	AZN1315		Spring	86	AZN1352		Spring
37	AZB1081		Screw	87	AZN1304		Spacer
38	AZN1316		Nylon band	88	AZN1470		Tube
39	AZN1983		P.C.board	89	AZB1100		Screw
40			Jumper wire	90	AZS1087		Solenoid
41			Head lead	91	AZB1101		Screw
42			Lead wire	92	AZB1102		Spring washer
43			Wire	93		
44			94	AZB1298		Screw
45			Mecha P.C.board calking assembly	95	AZN1833		Capstan holder
46	AZN1319		R reel assembly	96	AZN1834		Capstan holder
47	AZN1320		F reel assembly	97	AZN1344		Eject lever L
48	AZN1321		Reverse arm calking assembly	98		
49			FR lever calking assembly	99			Holder
50	AZN1975		PLAY lever calking assembly				

Mark	No.	Parts No.	Description
	200	AZB1084	Nut
	201	AZB1085	E ring
	202	AZB1086	D screw
	203	AZB1121	P washer
	204	AZB1087	N washer
A	205	AZB1089	U screw
	206	AZB1090	P washer
	207	AZB1091	Oil cut
	208	AZB1092	Oil cut
	209
	210	AZB1094	P washer
	211	AZB1095	D screw
	212
	213	AZB1097	P washer
	214	AZB1098	M washer
	215	AZB1105	P screw
	216	AZB1106	D screw
	300	AZX1020	Motor assembly
	301	AZP1041	Head frame assembly

A
B
C
D

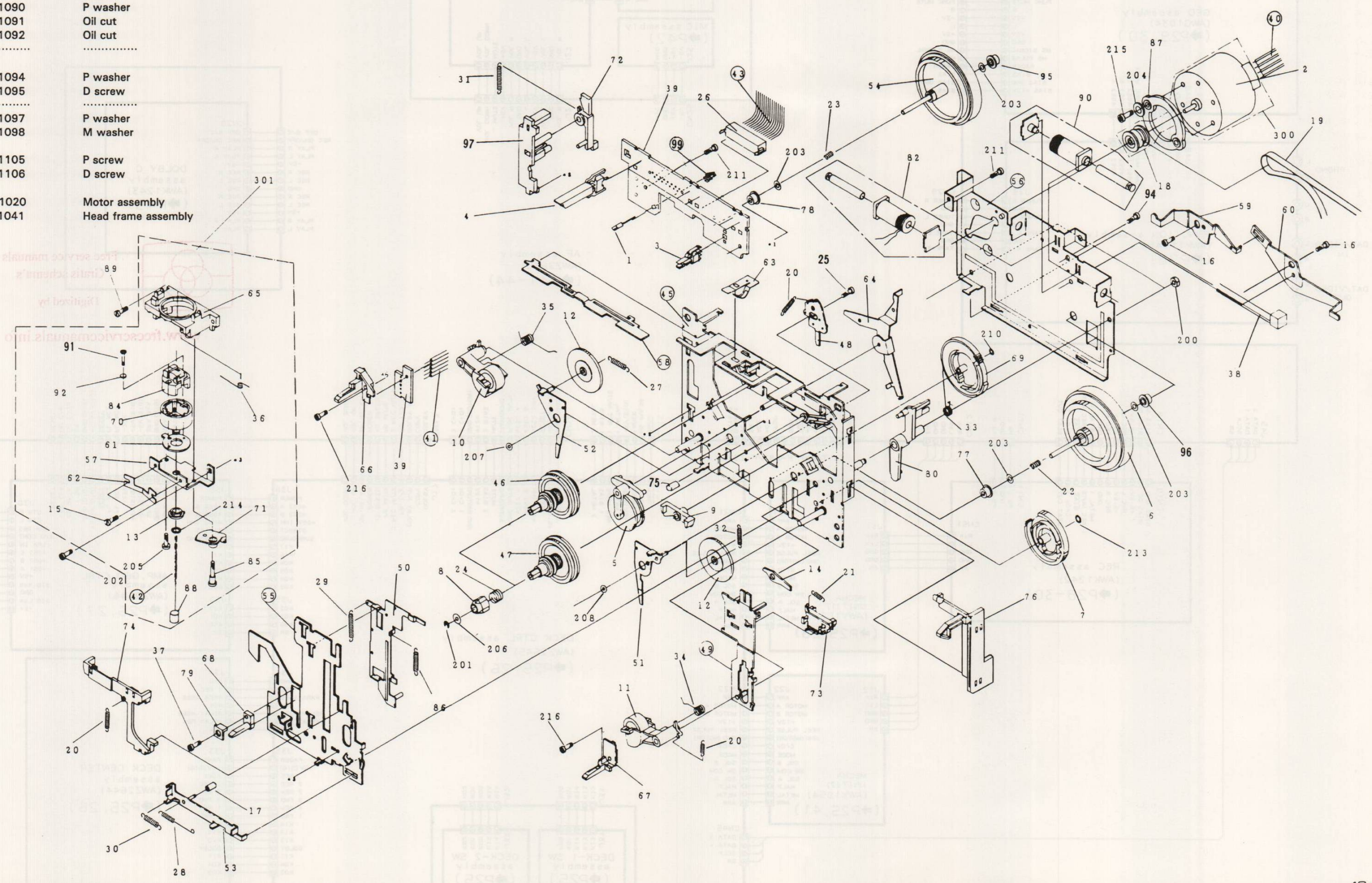

4. SCHEMATIC DIAGRAMS AND P.C.BOARD CONNECTION DIAGRAMS

4.1 OVER ALL SCHEMATIC DIAGRAM

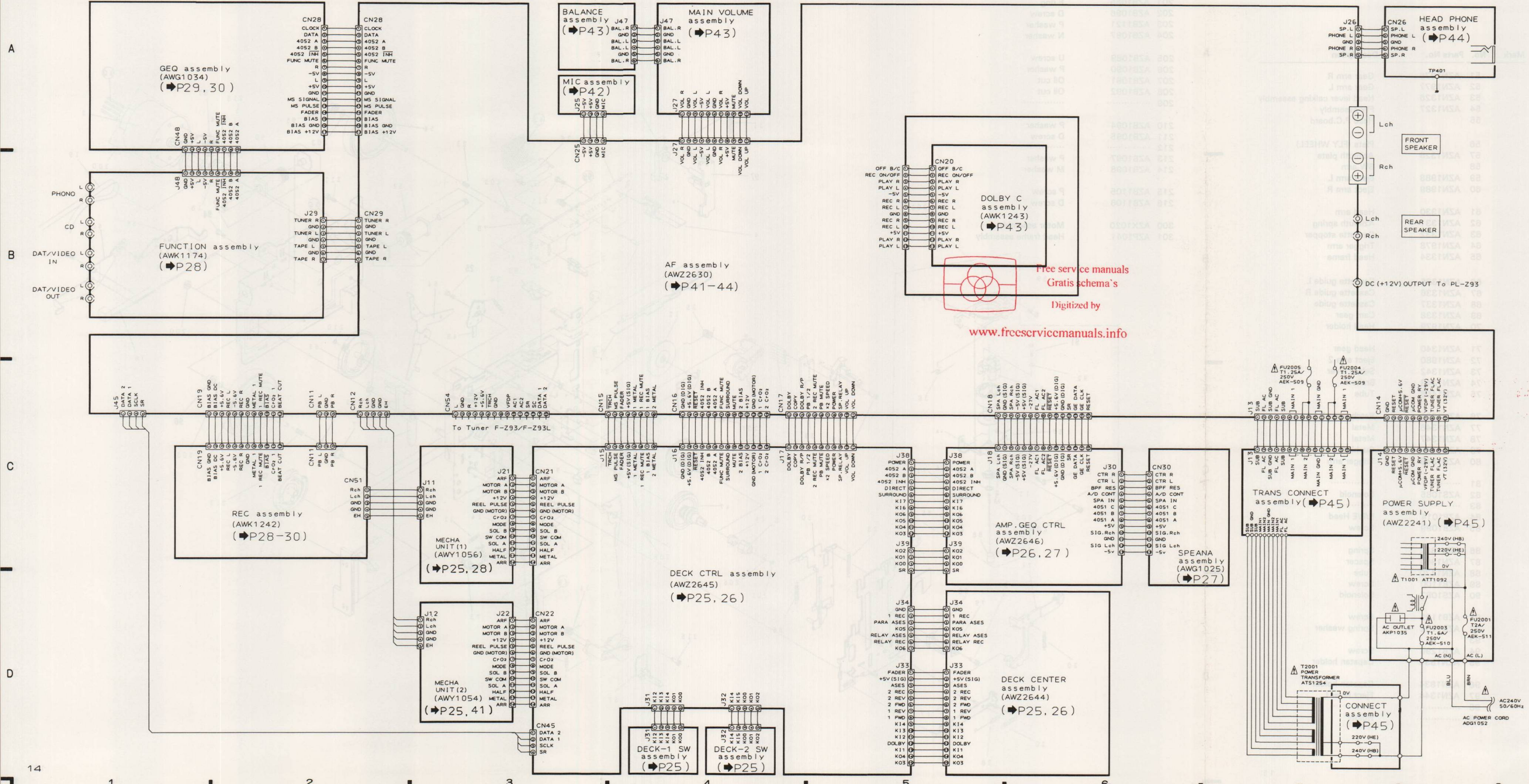

- RESISTORS:**
Indicated in Ω, ¼W, ½W, ±5% tolerance unless otherwise noted k : kΩ, M : MΩ, (F) : ±1%, (G) : ±2%, (K) : ±10% (M) : ±20% tolerance
 - CAPACITORS:**
Indicated in capacity (μF)/voltage (V) unless otherwise noted p : pF
Indication without voltage is 50V except electrolytic capacitor.
 - VOLTAGE, CURRENT:**
⊞ : Signal voltage at (60 W + 60 W 8Ω)output (1kHz)
⊞ : DC voltage (V) at no input signal
Value in () is DC voltage at rated power.
⊞ mA : DC current at no input signal
 - OTHERS:**
⊞ : Signal route.
⊞ : Adjusting point.
The ⊞ mark found on some component parts indicates the importance of the safety factor of the part. Therefore, when replacing, be sure to use parts of identical designation.
※ marked capacitors and resistors have parts numbers.
- This is the basic schematic diagram, but the actual circuit may vary due to improvements in design.
- | DECK-1 SW assembly | AMP,GEQ CTRL assembly |
|----------------------|-----------------------|
| S811 1FWD | S707 PHONO |
| S812 1REV | S711 TUNER |
| S813 1FF | S713 SURROUND |
| S814 1REV | S714 DAT DIRECT |
| S815 1STOP | S715 DAT |
| DECK-2 SW assembly | S716 CD DIRECT |
| S821 2FWD | S717 POWER |
| S822 2REV | S718 CD |
| S823 2FF | S722 TAPE |
| S824 2REV | S771 60Hz + |
| S825 2STOP | S772 150Hz + |
| DECK CENTER assembly | S773 400Hz + |
| S848 DOLBY OFF-B-C | S774 1kHz + |
| S849 REVERSE MODE | S775 2.4kHz + |
| S851 DECK-2 MUTE | S776 6kHz + |
| S852 DECK-1 MUTE | S777 15kHz + |
| S853 COPY | S778 60Hz - |
| S854 DECK-2 PAUSE | S779 150Hz - |
| S855 PARA A.S.E.S | S780 400Hz - |
| S856 PARA REC | S781 1kHz - |
| S857 FADER | S782 2.4kHz - |
| S858 DECK-2 REC | S783 6kHz - |
| S859 RELAY A.S.E.S | S784 15kHz - |
| S860 DECK-1 PAUSE | S785 A |
| S862 HI-SPEED COPY | S786 B |
| S863 RELAY REC | S787 C |
| S864 DECK-1 REC | S788 D |
| S873 A.S.E.S | S789 E |
| | S790 PRESET/MEMORY |
| | S791 EQUALIZER ON/OFF |
| | S792 FLAT/REVERSE |
| | S793 MEMORY |
- The underline indicates the switch position

NOTE:
This picture shows the foil side of the printed circuit.

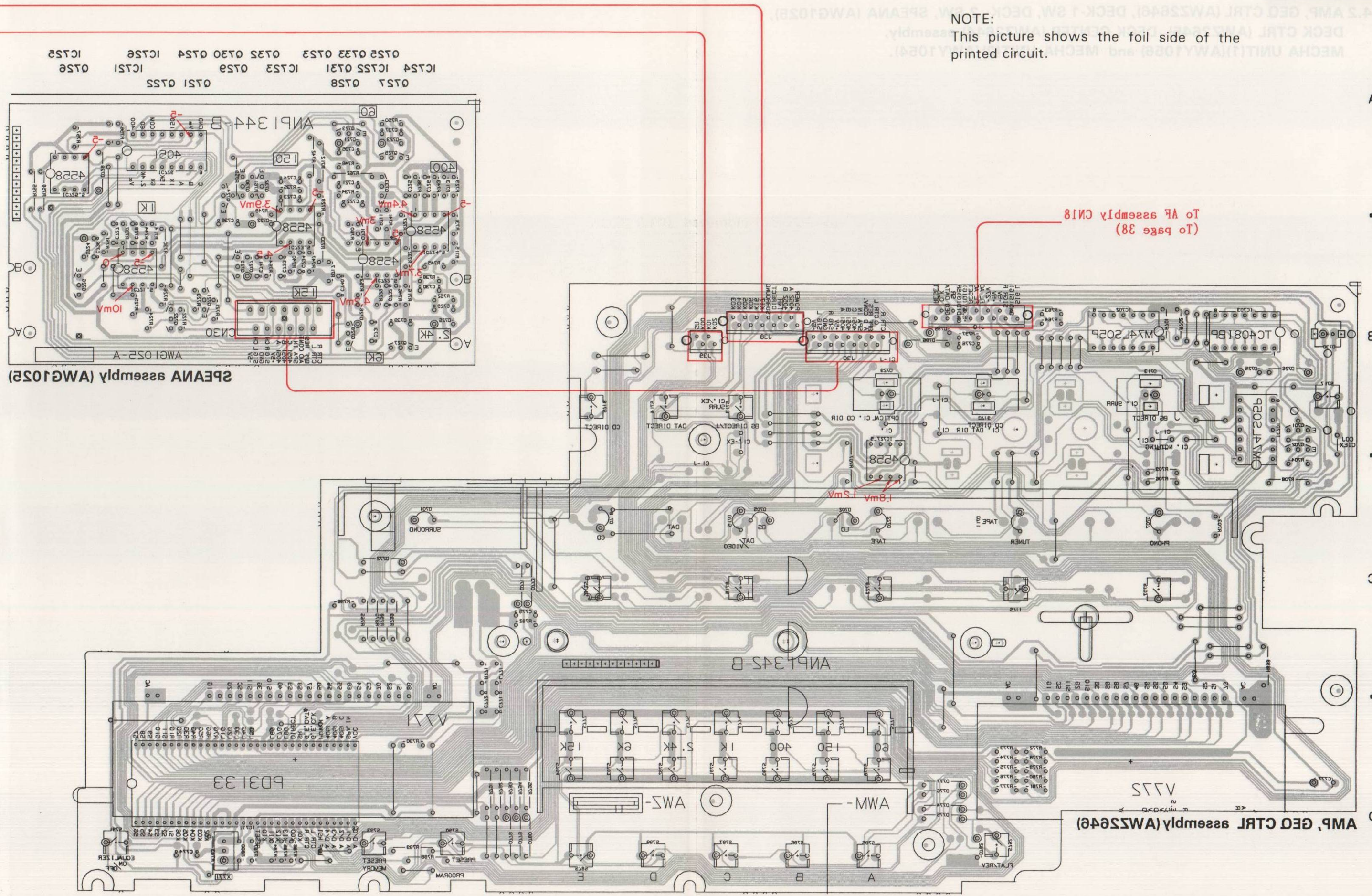

Part Name

VR	Variable resistor	VR
F	Flicker	F
C	Capacitor	C
R	Resistor	R
D	Diode	D
TR	Transistor	TR
IC	IC	IC

Part Name

VR	Variable resistor	VR
F	Flicker	F
C	Capacitor	C
R	Resistor	R
D	Diode	D
TR	Transistor	TR
IC	IC	IC

NOTE:
1. The P.C.B. connection diagram is viewed from the parts mounted side.
2. The parts which have been mounted on the board can be replaced with those from the corresponding wiring symbols listed in the following Table.
3. The capacitor terminal marked with @ (double circles) shows negative terminal.
4. The diode terminal marked with @ (double circles) shows cathode side.
5. The transistor terminal marked with @ (double circles) shows emitter.

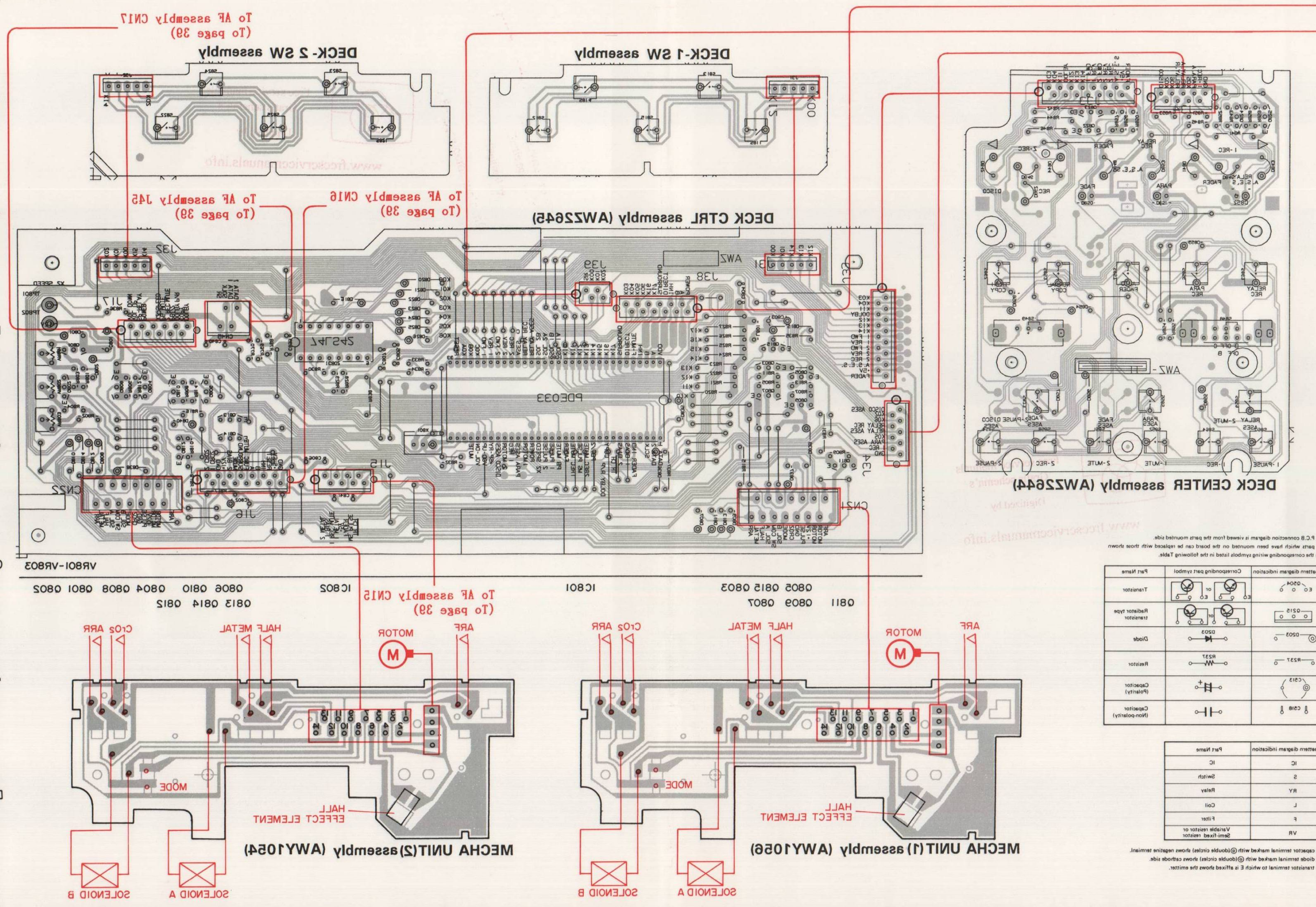

4.2 AMP, GEQ CTRL (AWZ2646), DECK-1 SW, DECK- 2 SW, SPEANA (AWG1025), DECK CTRL (AWZ2645), DECK CENTER (AWZ2644) assembly, MECHA UNIT(1)(AWY1056) and MECHA UNIT(2)(AWY1054).

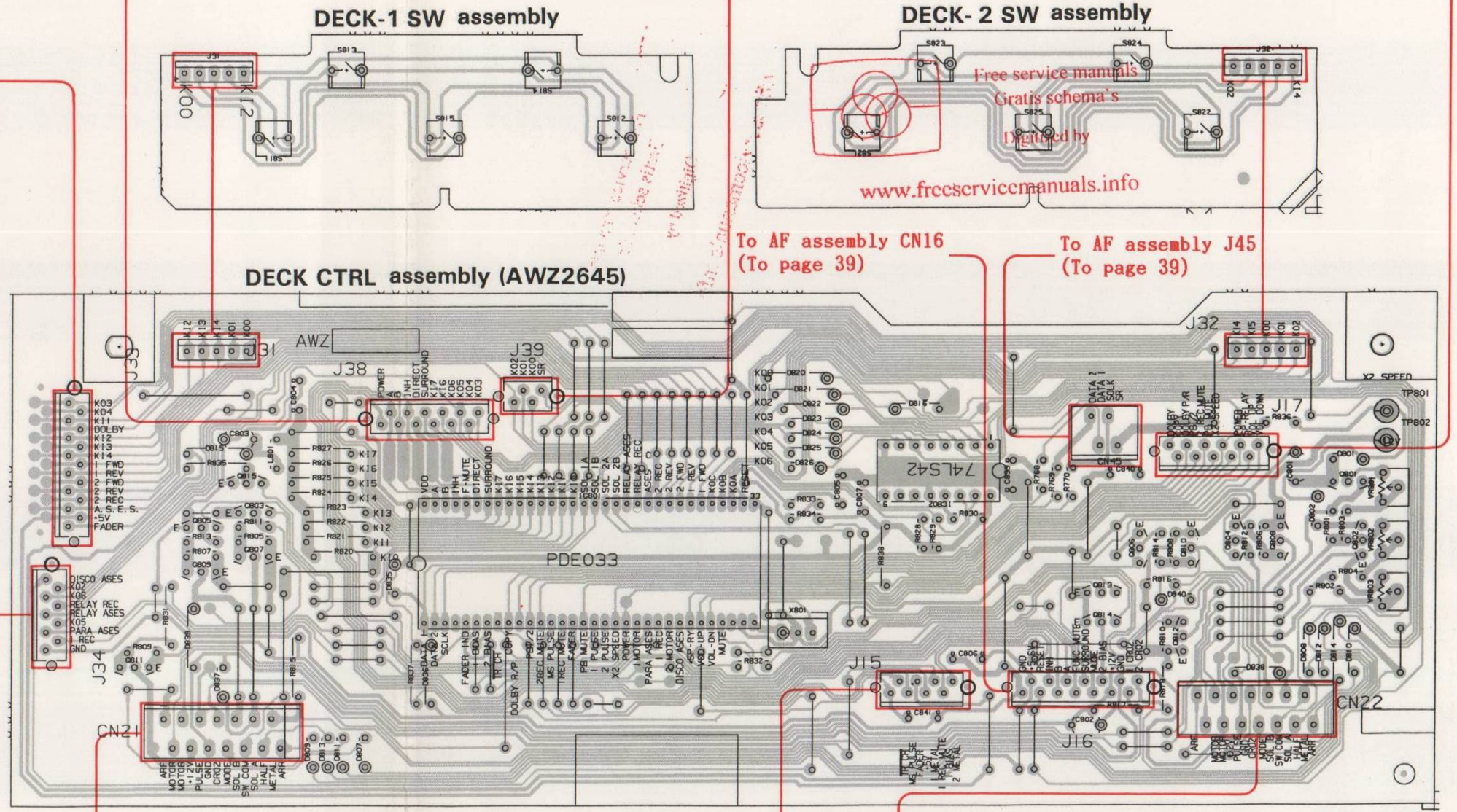
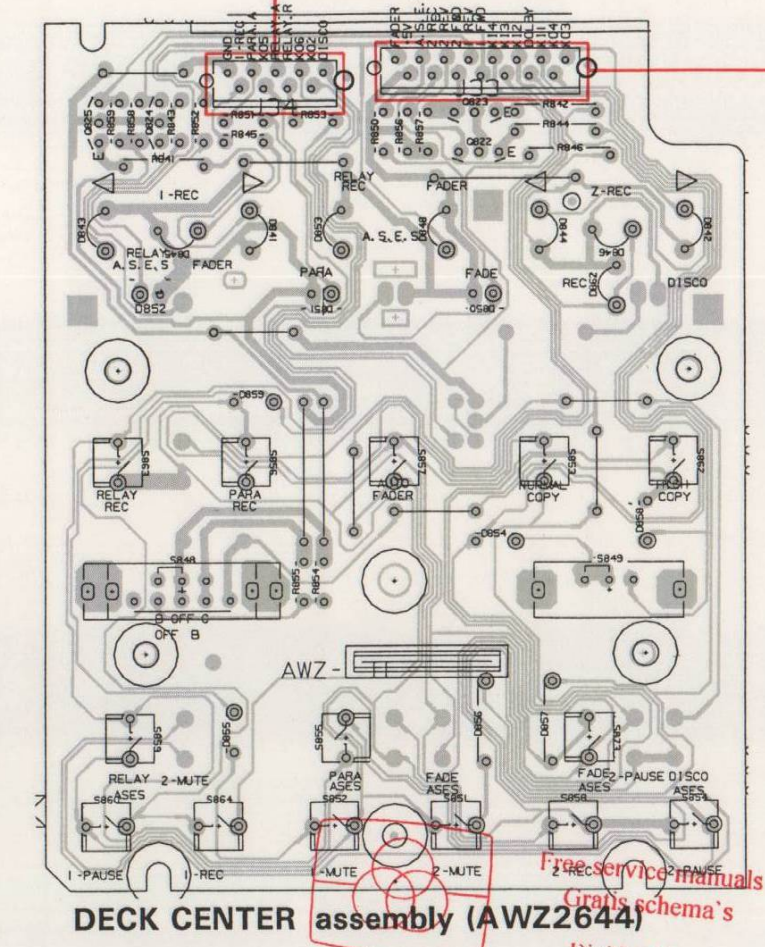
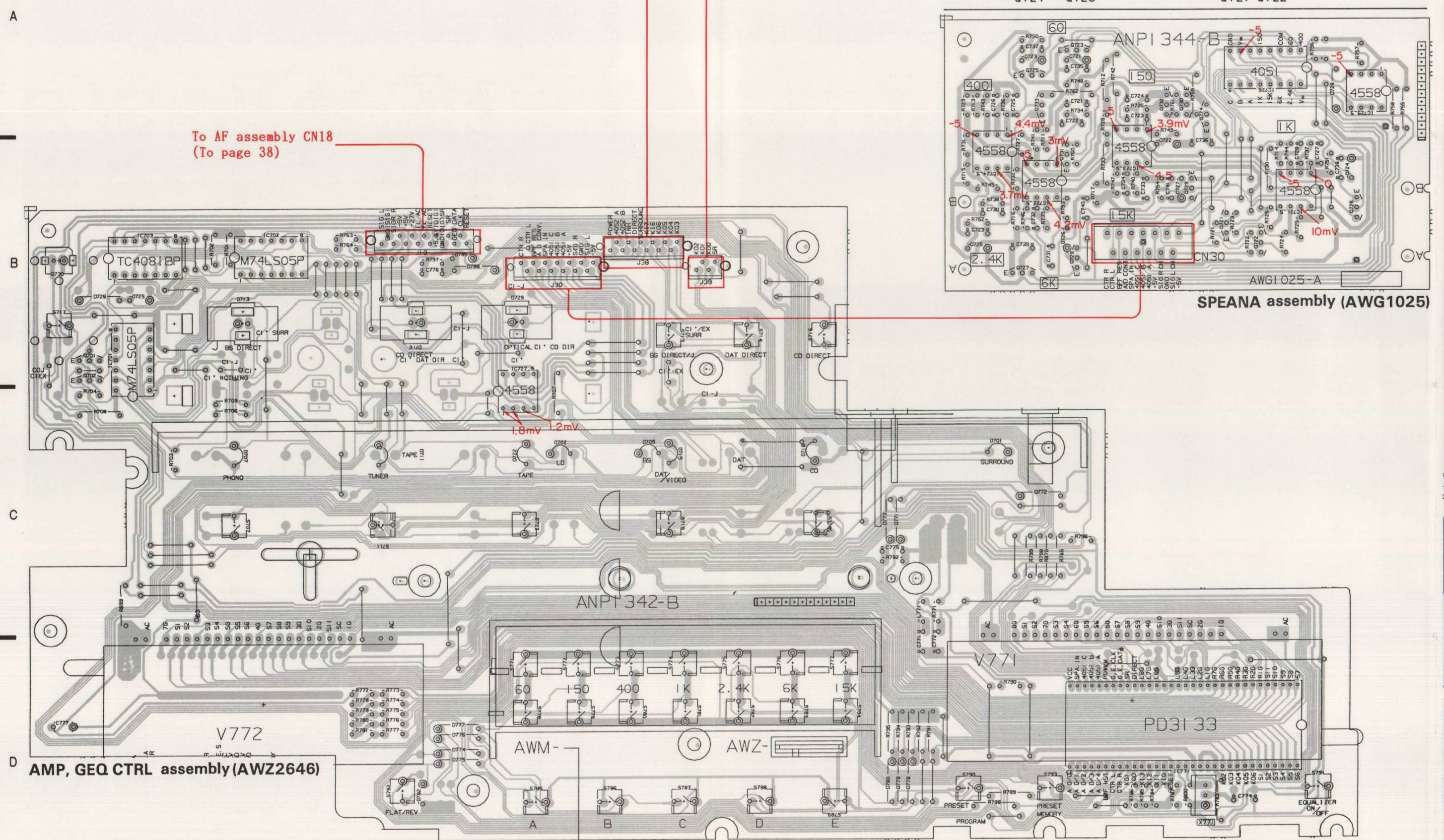

NOTE

1. This P.C.B connection diagram is viewed from the parts mounted side.
2. The parts which have been mounted on the board can be replaced with those shown with the corresponding wiring symbols listed in the following Table.

P.C.B. pattern diagram indication	Corresponding part symbol	Part Name
⊙-D504		Transistor
⊙-D215		Radiator type transistor
⊙-D203		Diode
⊙-R237		Resistor
⊙-C513		Capacitor (Polarity)
⊙-C518		Capacitor (Non-polarity)

Others

P.C.B. pattern diagram indication	Part Name
IC	IC
S	Switch
RY	Relay
L	Coil
F	Filter
VR	Variable resistor or Semi-fixed resistor

3. The capacitor terminal marked with ⊙(double circles) shows negative terminal.
4. The diode terminal marked with ⊙(double circles) shows cathode side.
5. The transistor terminal to which E is affixed shows the emitter.

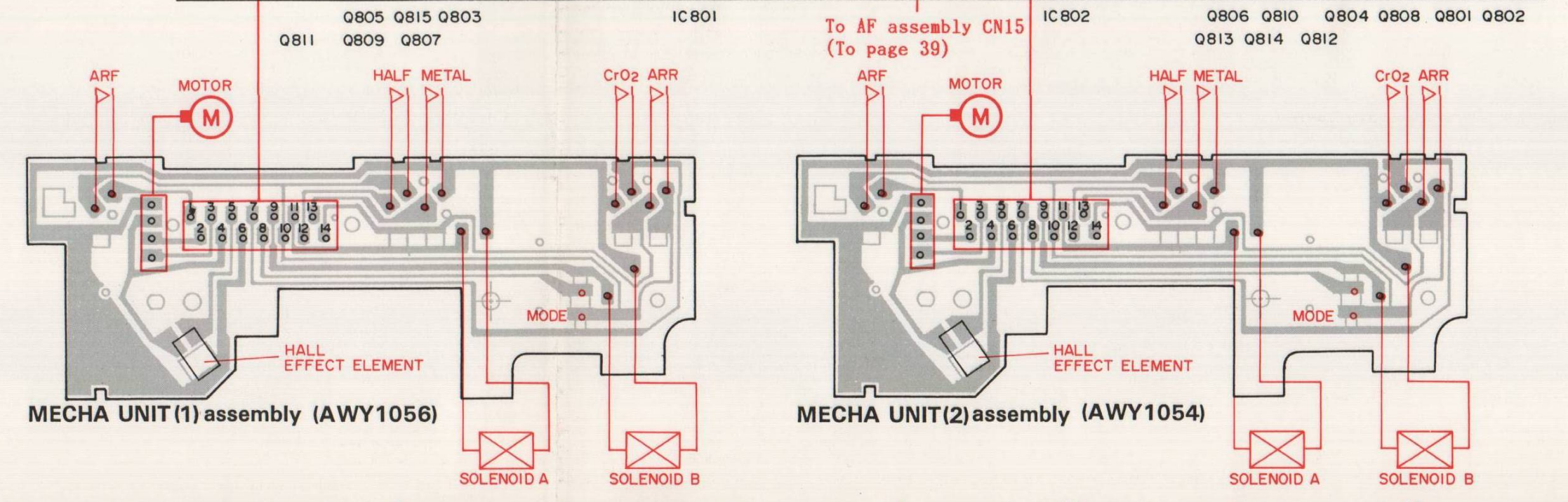

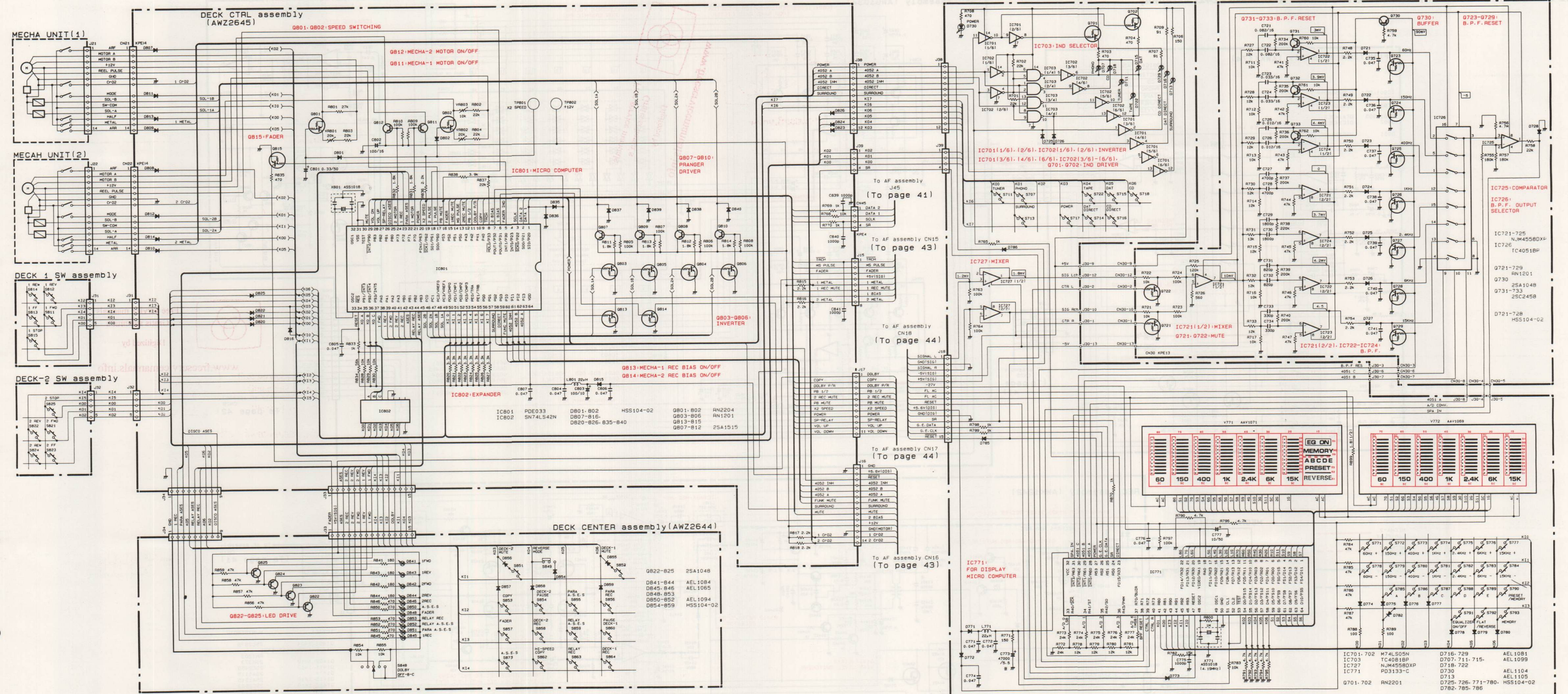

DECK CTRL assembly (AWZ2645)

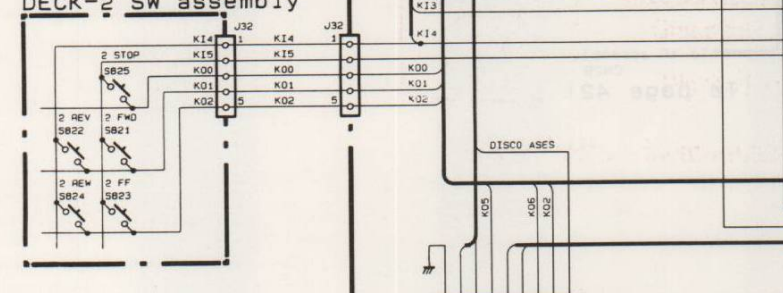
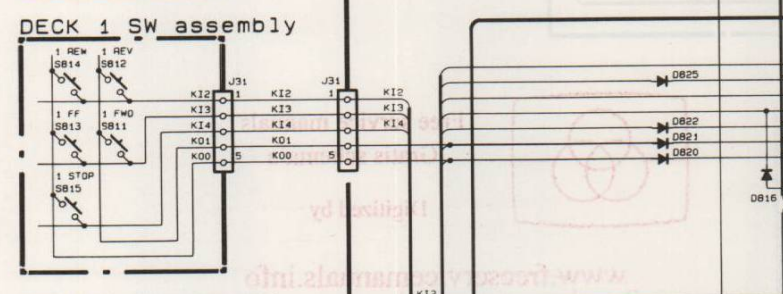
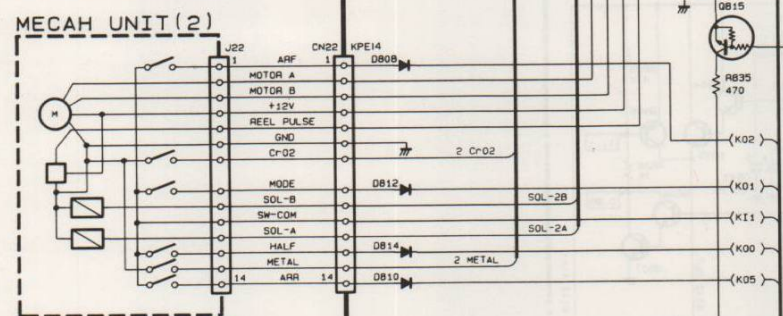
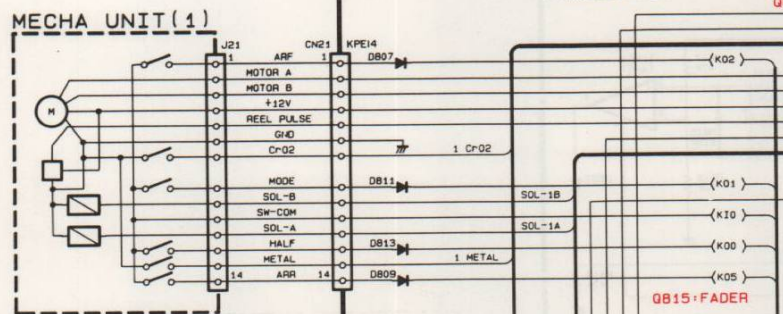

DECK CENTER assembly (AWZ2644)

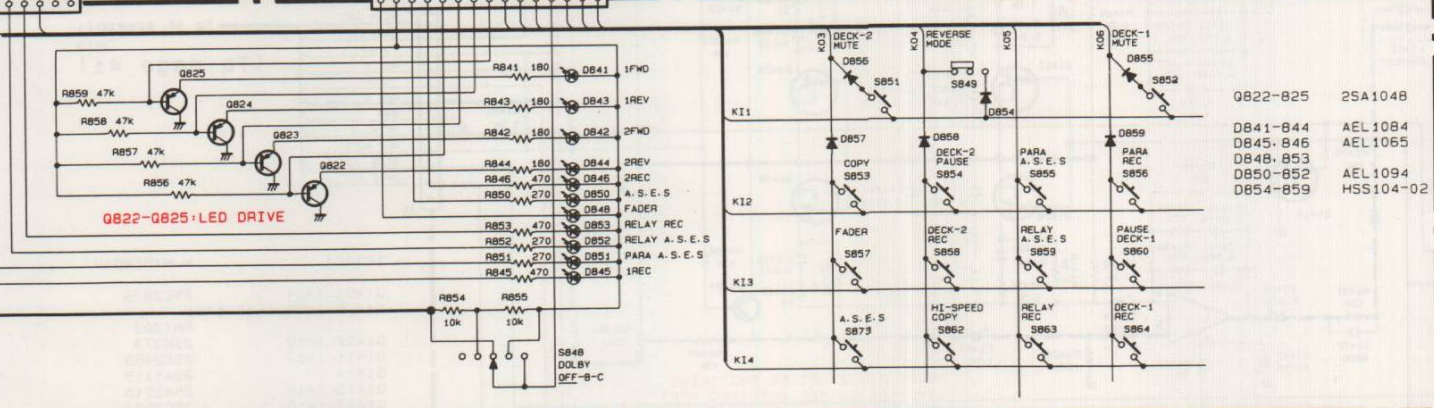

AMP. GEG CTRL assembly (AWZ2646)

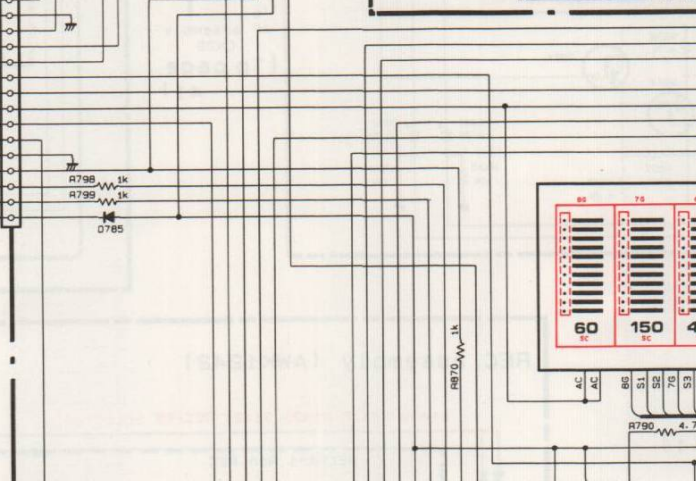
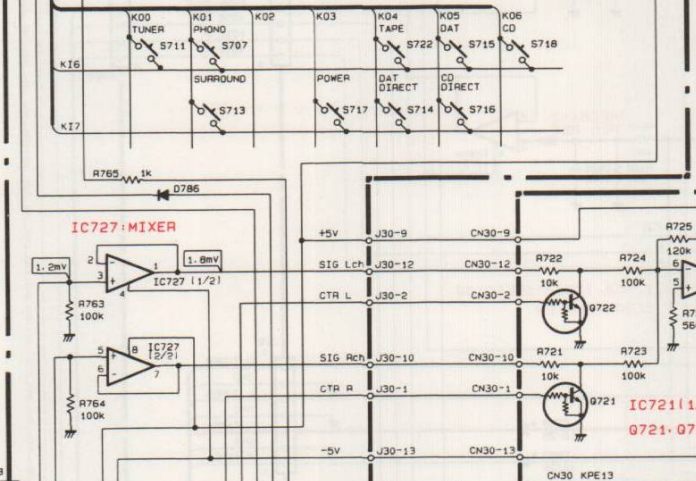
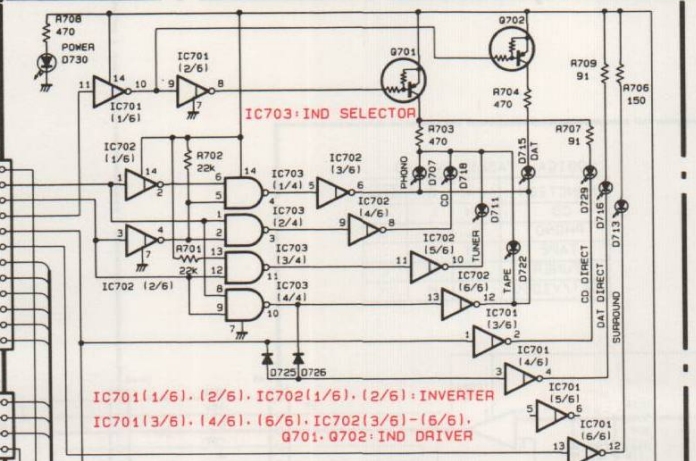

SPEANA assembly (AWG1025)

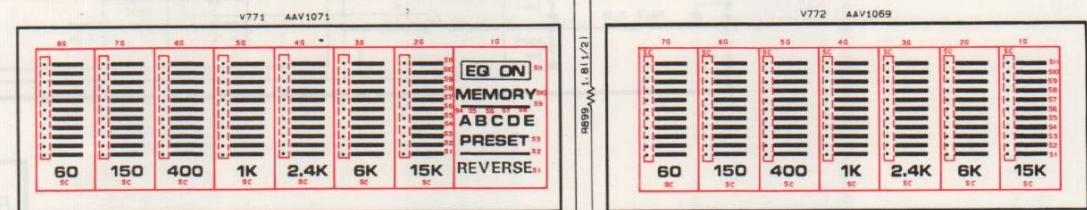
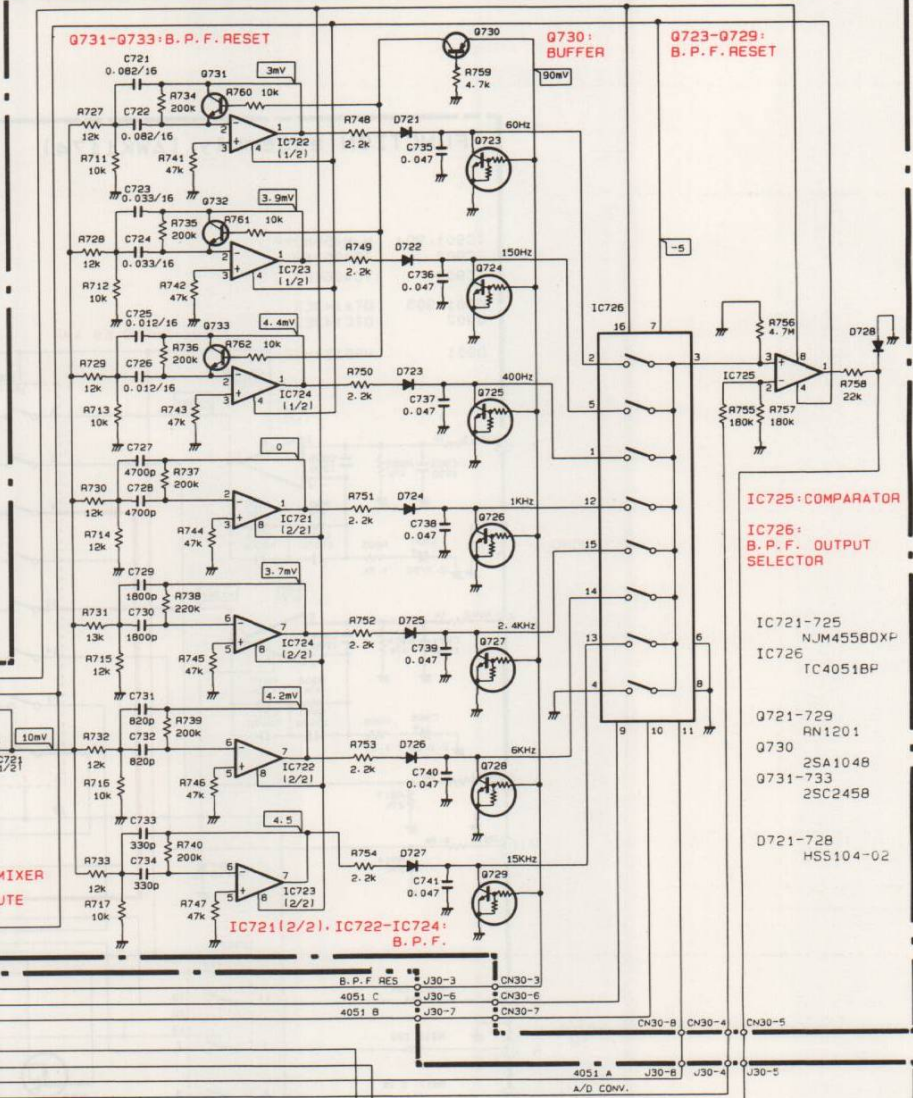

- Q822-Q825 2SA1048
- Q841-Q844 AEL1084
- Q845-Q846 AEL1085
- Q848-Q853 AEL1094
- Q850-Q852 AEL1094
- Q854-Q859 HSS104-02

- IC701-702 M74LS05N
- IC703 TC4081BP
- IC727 NUM4558XP
- IC771 PD3133-C
- Q701-702 RN2201
- D716-729 AEL1081
- Q707-711-715 AEL1099
- D718-722 AEL1104
- Q730 AEL1105
- D725-726-771-780 HSS104-02
- D782-785-786

4.3 FUNCTION (AWK1174), GEQ (AWG1034) and REC (AWK1242) assembly

A

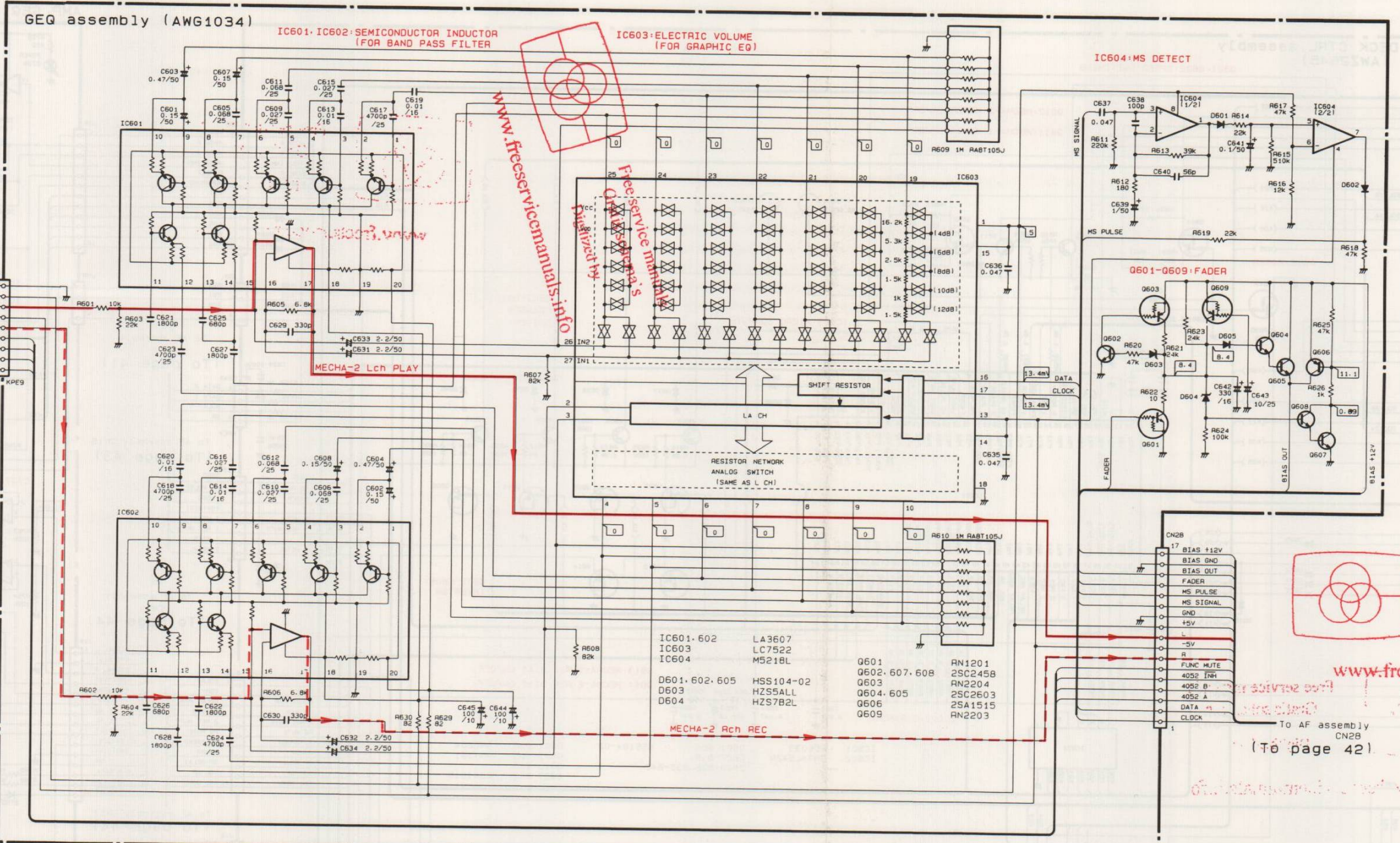
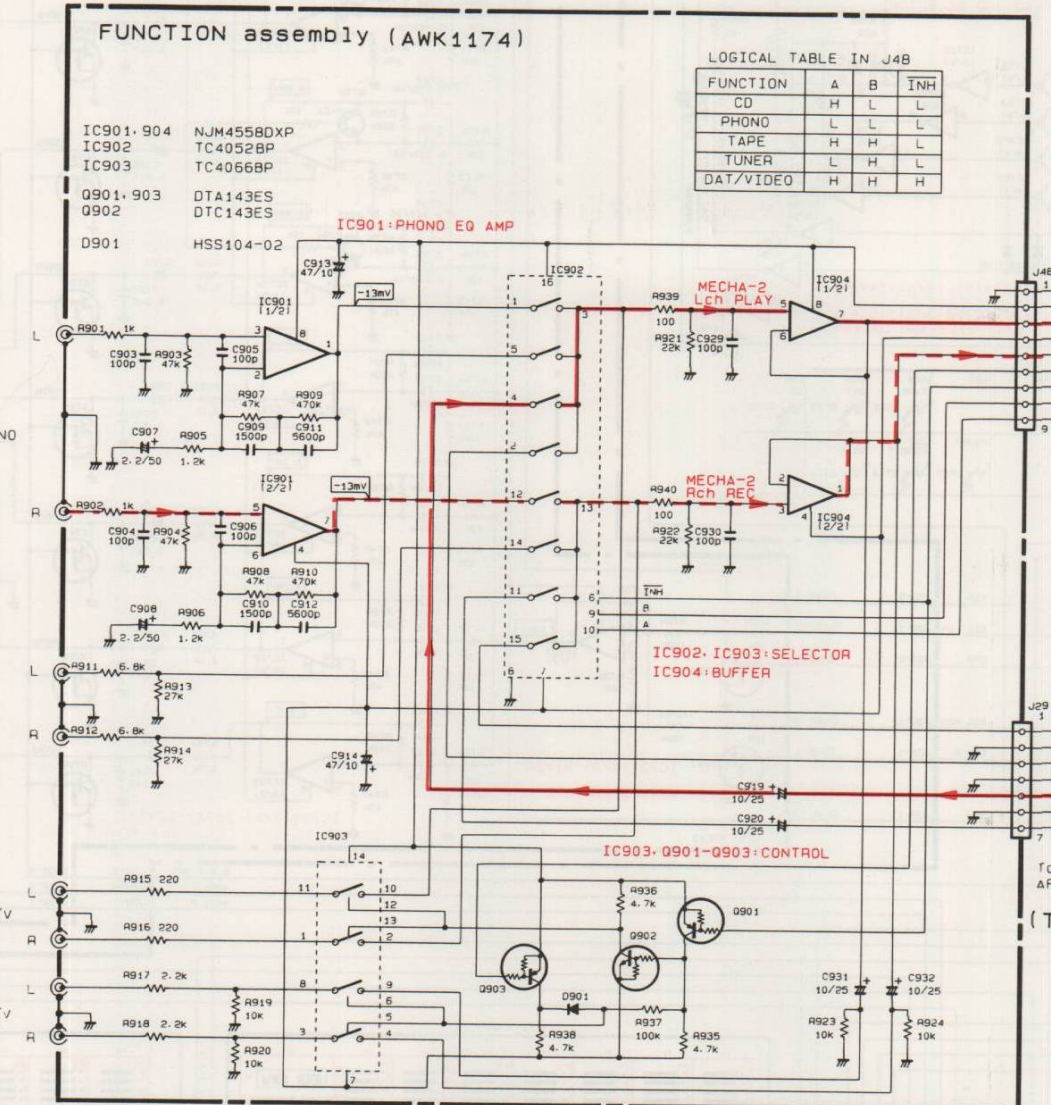

B

C

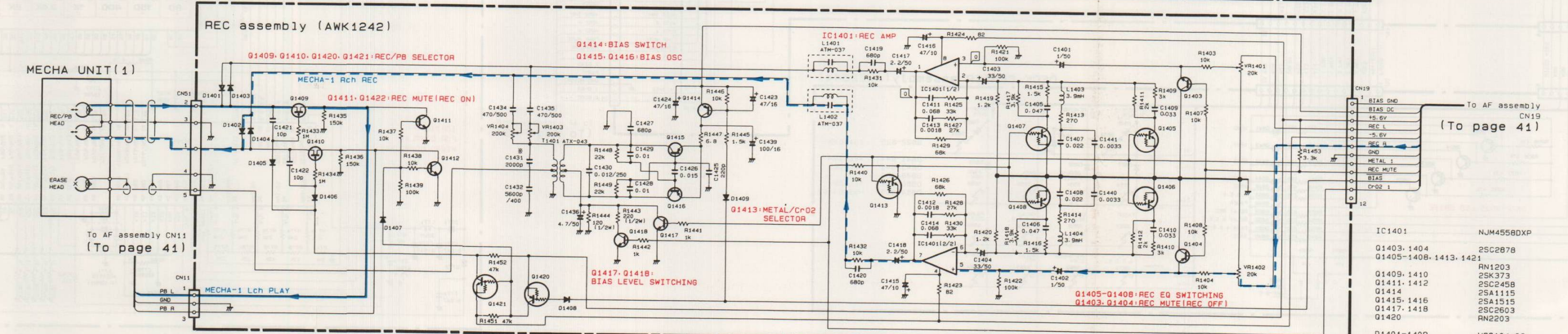
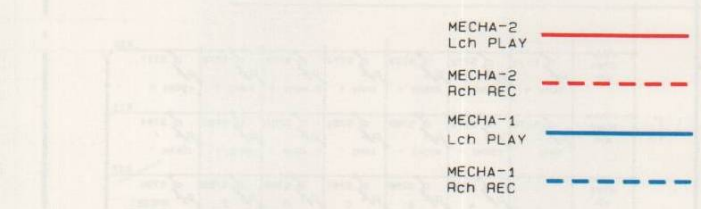

D

Free service manuals
 Gratis schema's
 Digitized by
 www.freemove.com

A

B

C

D

A

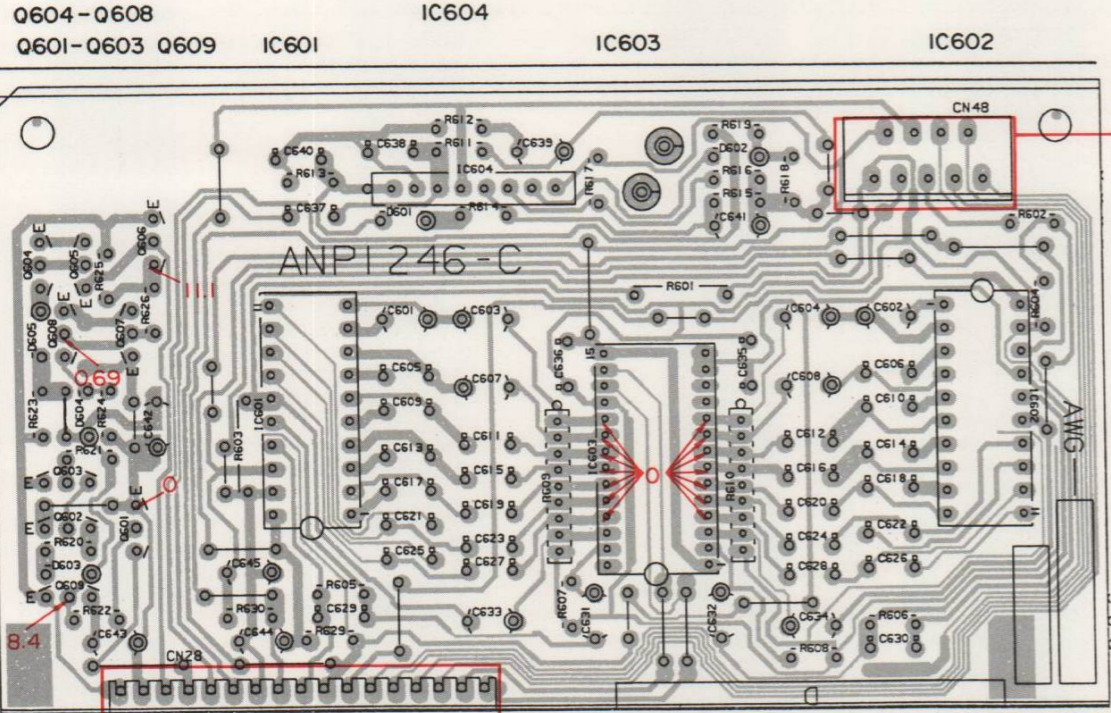

GEQ assembly (AWG1034)

To AF assembly CN28
(To page 39)

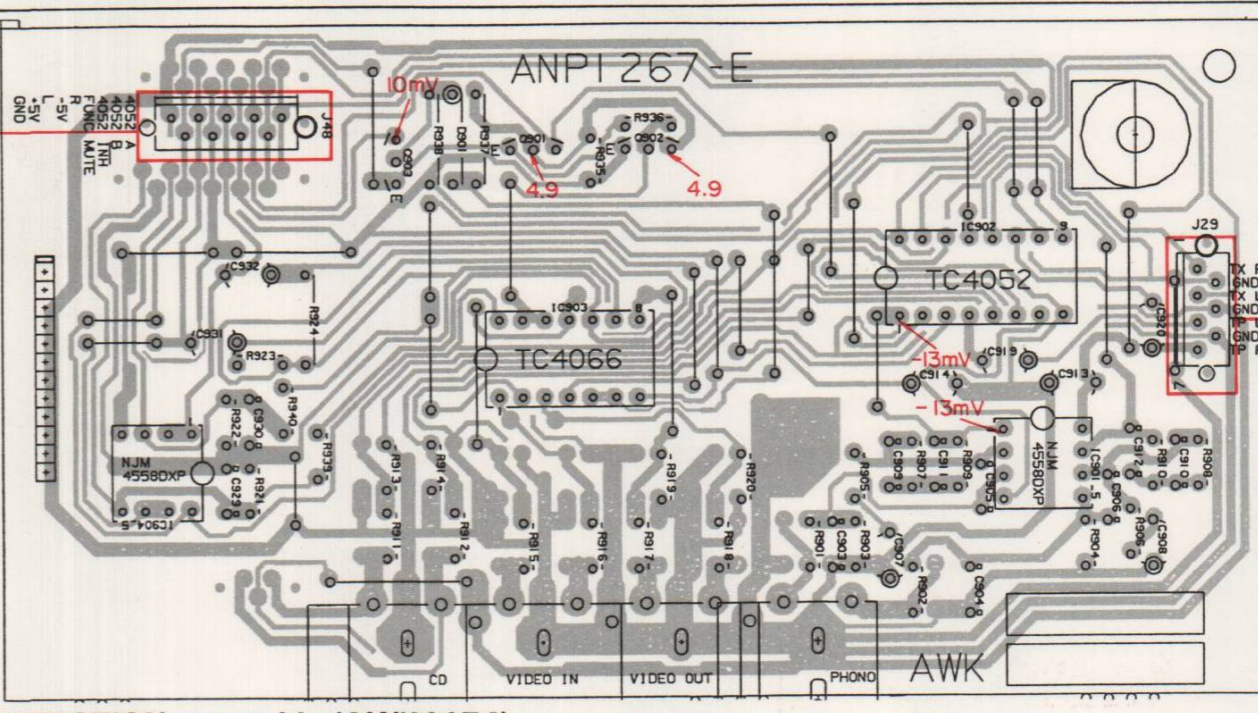

FUNCTION assembly (AWK1174)

To AF assembly CN29
(To page 39)

C

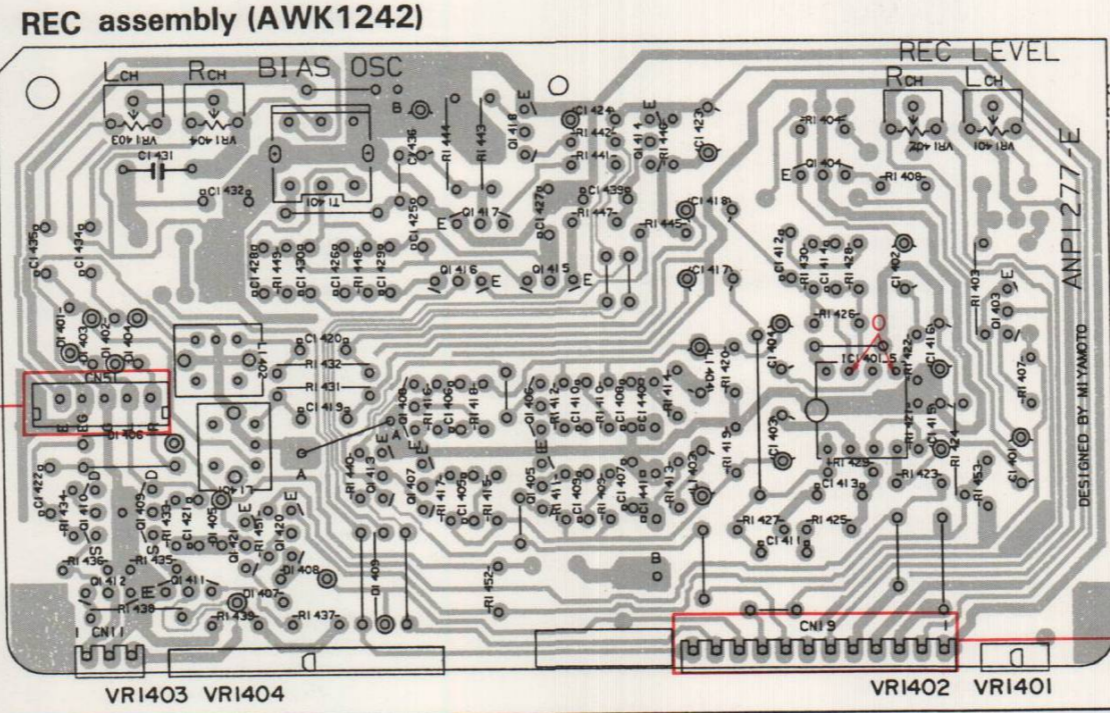

REC assembly (AWK1242)

To AF assembly CN19
(To page 39)

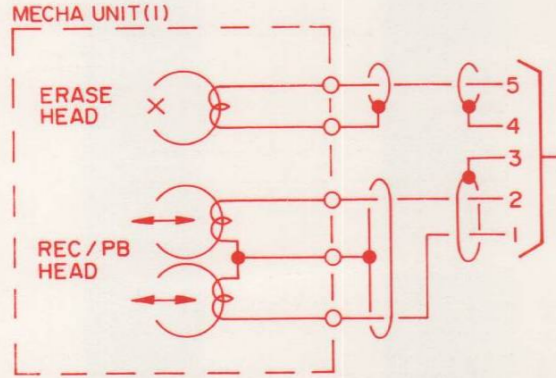

NOTE

- This P.C.B connection diagram is viewed from the parts mounted side.
- The parts which have been mounted on the board can be replaced with those shown with the corresponding wiring symbols listed in the following Table.

P.C.B. pattern diagram indication	Corresponding part symbol	Part Name
		Transistor
		Radiator type transistor
		Diode
		Resistor
		Capacitor (Polarity)
		Capacitor (Non-polarity)

Others

P.C.B. pattern diagram indication	Part Name
IC	IC
S	Switch
RY	Relay
L	Coil
F	Filter
VR	Variable resistor or Semi-fixed resistor

- The capacitor terminal marked with ⊙ (double circles) shows negative terminal.
- The diode terminal marked with ⊙ (double circles) shows cathode side.
- The transistor terminal to which E is affixed shows the emitter.

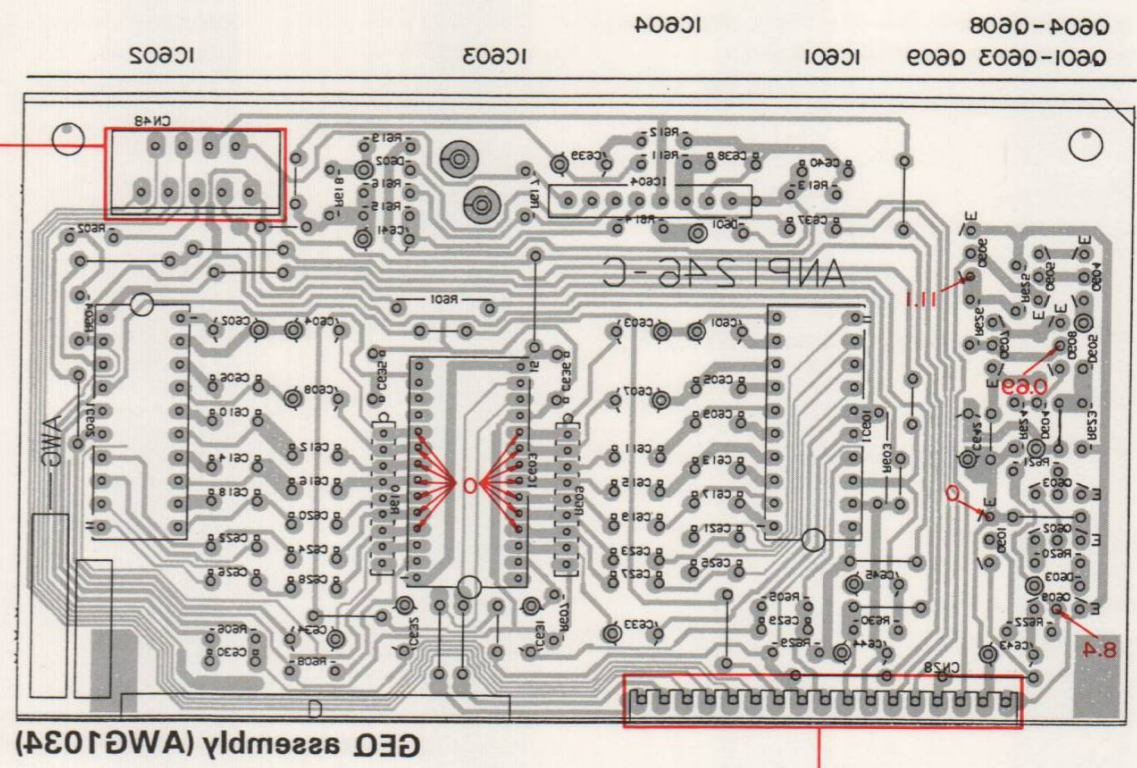

REC assembly (WK124S)

To AF assembly CN28
(To page 38)

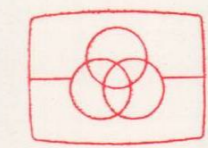

Free service manuals
Gratis schema's
Digitized by

www.freescrvice manuals.info

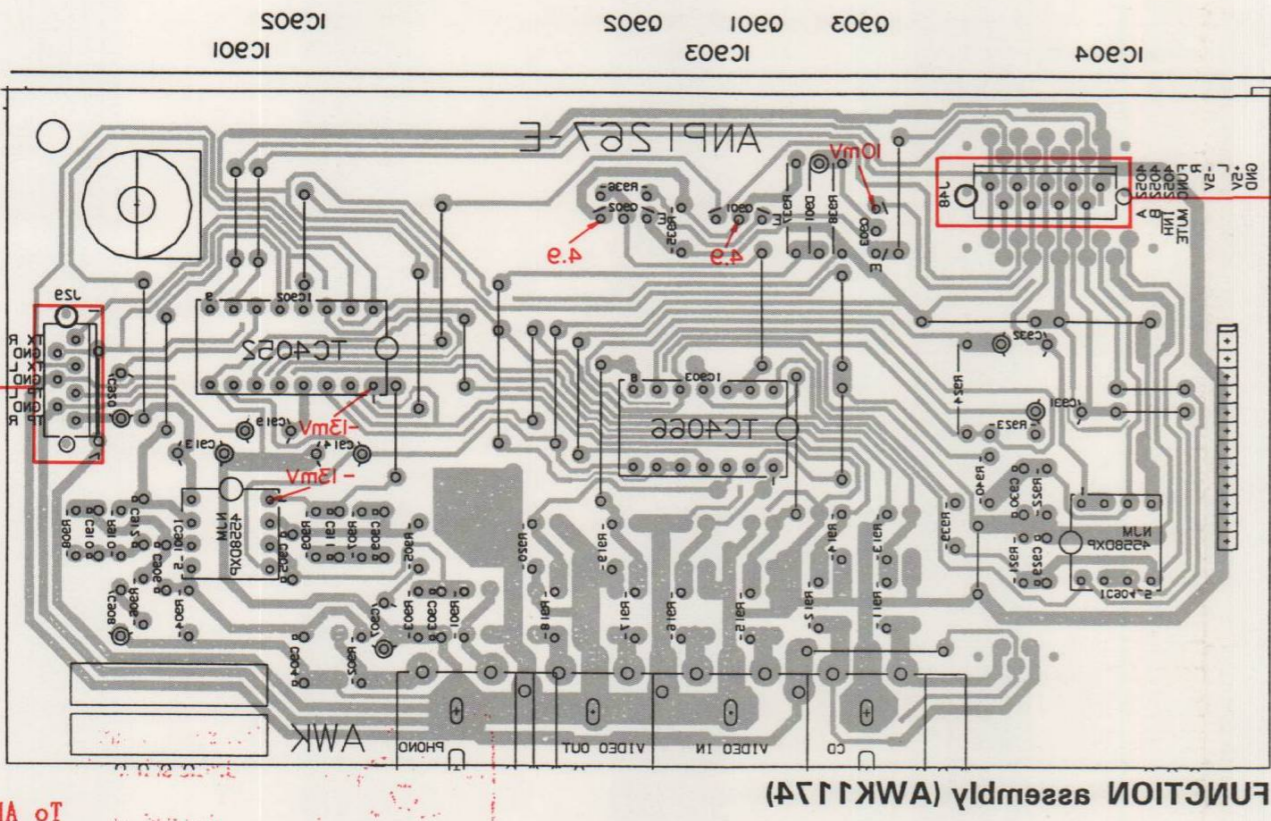
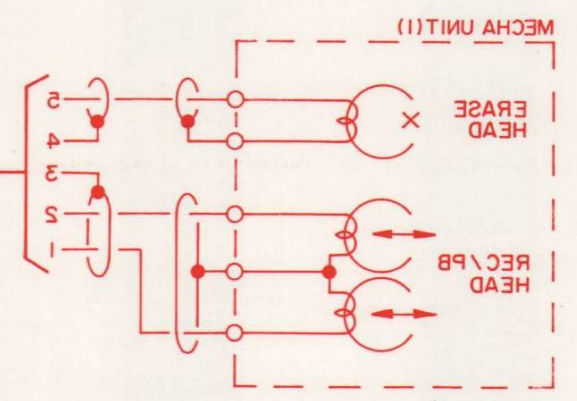

FUNCTION assembly (WK1174)

To AF assembly CN28
(To page 38)

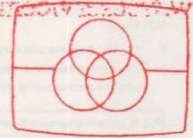

Free service manuals
Gratis schema's
Digitized by

www.freescrvice manuals.info

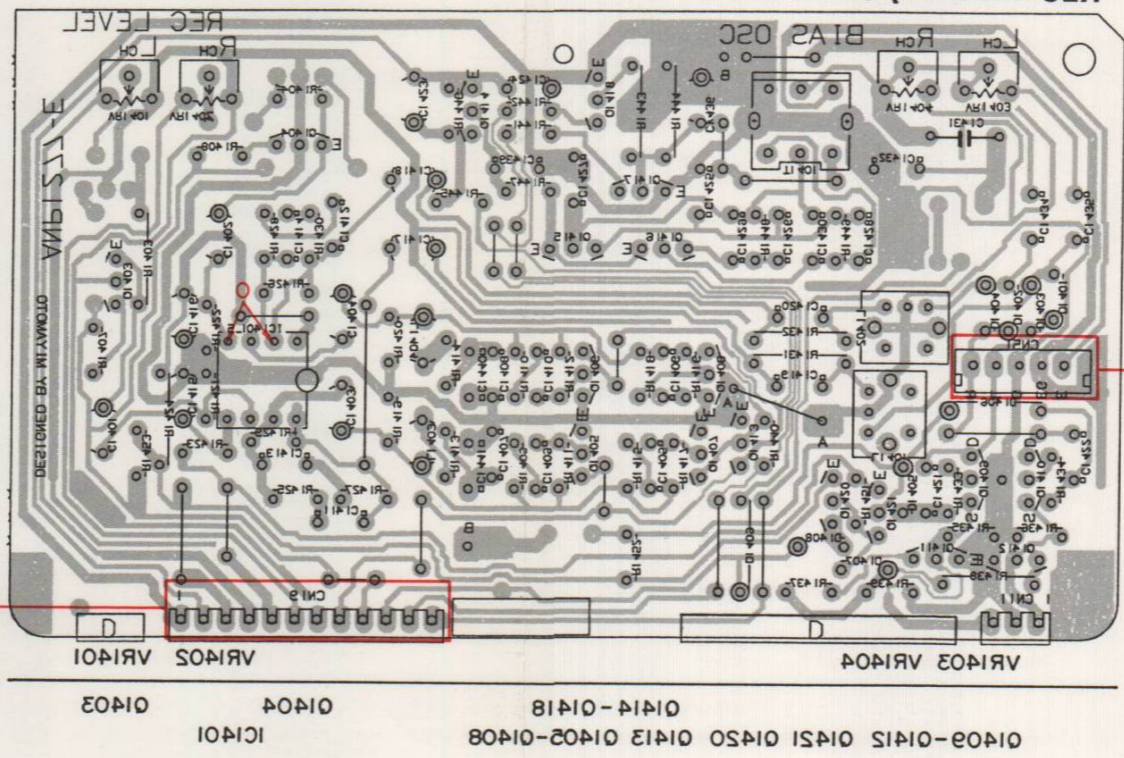

REC assembly (WK124S)

To AF assembly CN18
(To page 38)

NOTE:
This picture shows the foil side of the
printed circuit.

4.4 AF (AWZ2630), DOLBY C (AWK1243), MIC, BALANCE, MAIN VR and HEADPHONE assembly

Q351-Q356 IC331 IC306 Q491-Q494 IC501 Q481-Q483 IC471 Q527 IC522 IC523 Q528 Q570 Q521-Q524 IC521 IC412 IC431 Q431-Q438 Q580-Q584 Q414 Q413 Q575-Q579 Q571-Q573 Q411 Q412 IC311 Q321 Q322 IC321 IC309 IC332

DOLBY C assembly (AWK1243)

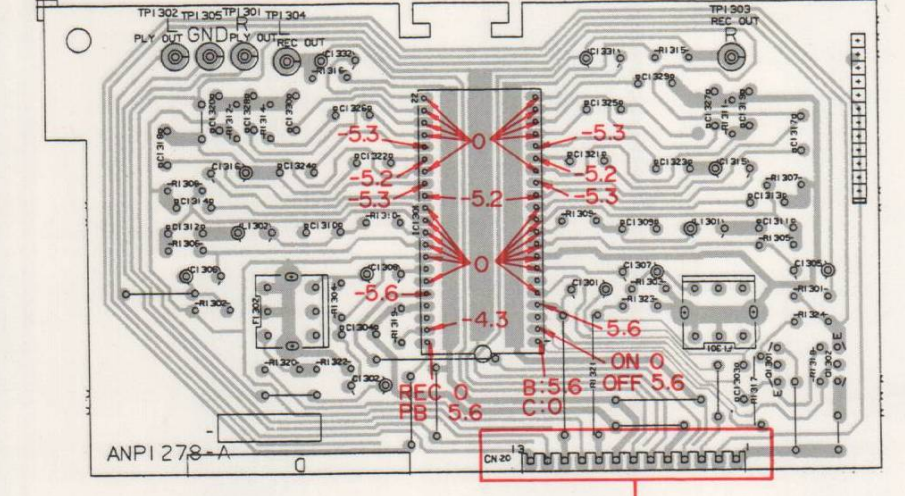

To TRANS CONNECT assembly J13 (To page 47)

To PL-Z93 To Tuner F-Z93/F-Z93L

To DECK CTRL assembly CN45 (To page 24)

To FUNCTION assembly J29 (To page 32)

To GEQ assembly CN28 (To page 31)

To REC assembly CN19 (To page 32)

To DECK CTRL assembly J16 (To page 24)

To DECK CTRL assembly J17 (To page 24)

To DECK CTRL assembly J15 (To page 24)

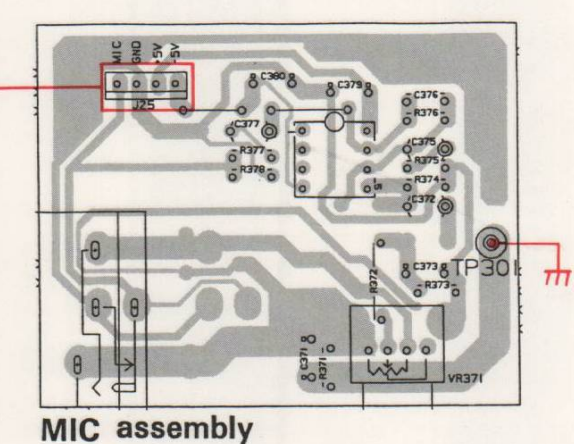
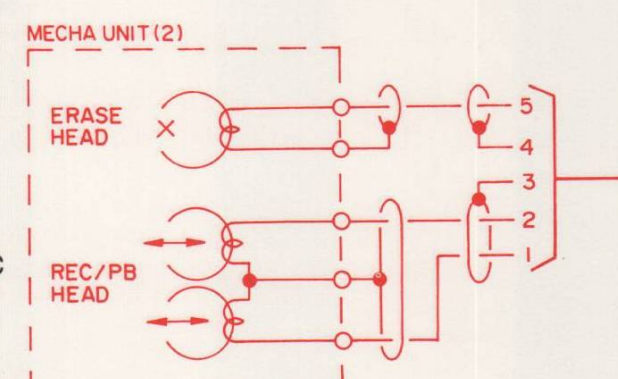

MIC assembly

To POWER SUPPLY assembly J14 (To page 46)

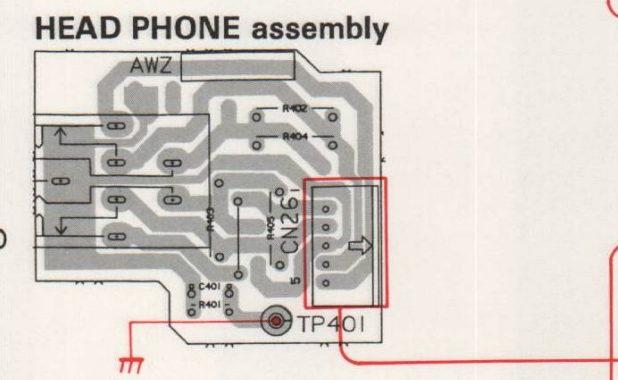

To AMP GEQ CTRL assembly J18 (To page 21)

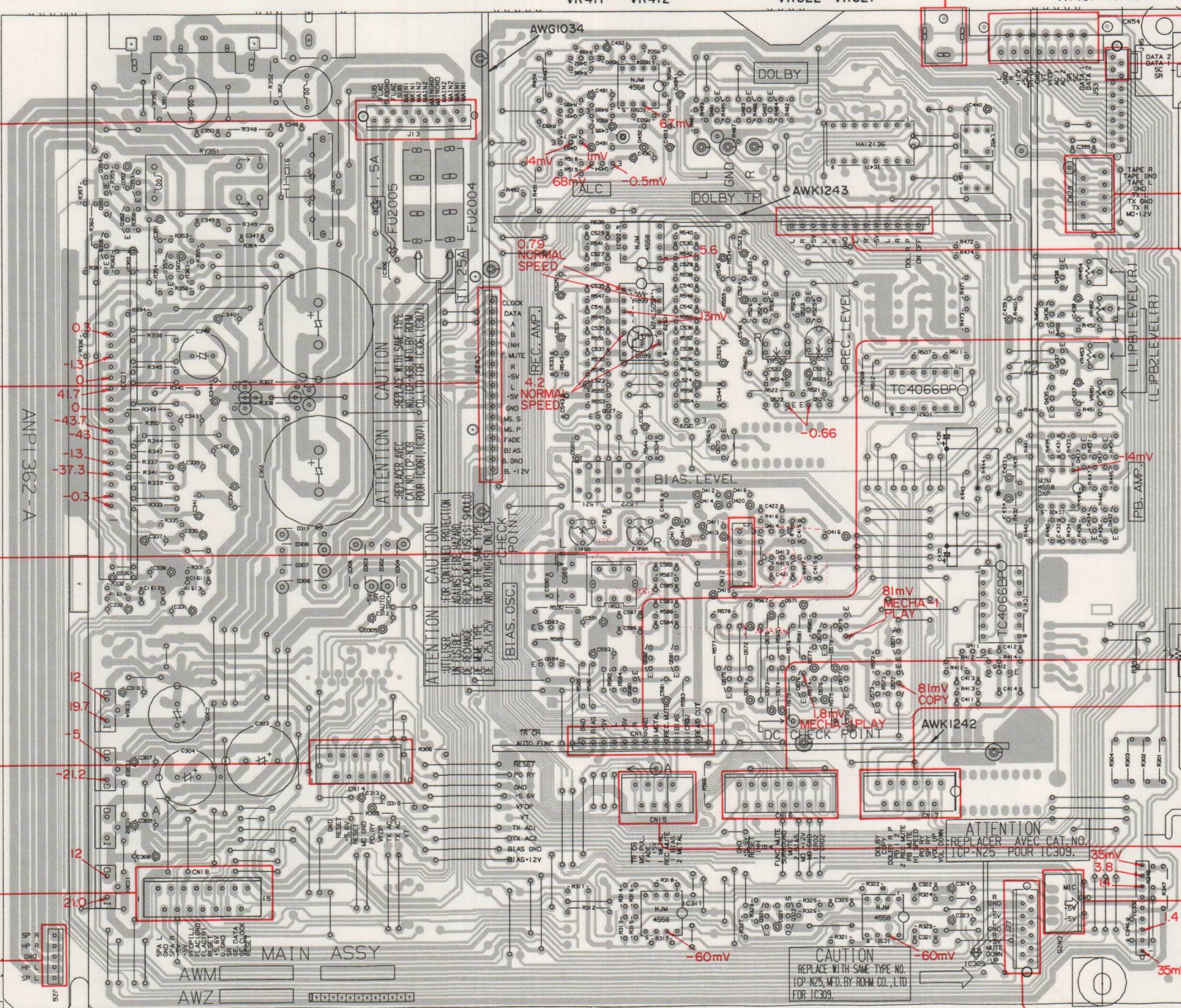

BALANCE assembly

MAIN VR assembly

NOTE

- 1. This P.C.B. connection diagram is viewed from the parts mounted side.
2. The parts which have been mounted on the board can be replaced with those shown with the corresponding wiring symbols listed in the following Table.

Table with 3 columns: P.C.B. pattern diagram indication, Corresponding part symbol, Part Name. It lists symbols for Transistor, Radiator type transistor, Diode, Resistor, Capacitor (Polarity), and Capacitor (Non-polarity).

Table with 2 columns: P.C.B. pattern diagram indication, Part Name. It lists symbols for IC, Switch, Relay, Coil, Filter, and Variable resistor or Semi-fixed resistor.

- 3. The capacitor terminal marked with ⊕ (double circles) shows negative terminal.
4. The diode terminal marked with ⊕ (double circles) shows cathode side.
5. The transistor terminal to which E is affixed shows the emitter.

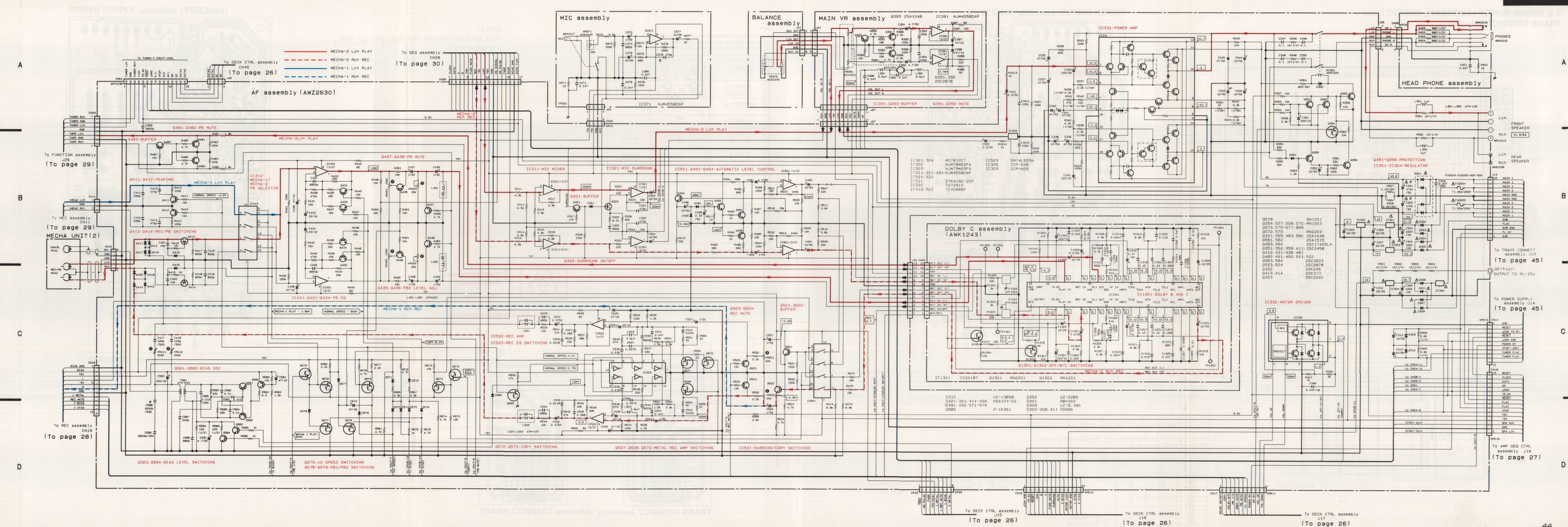

4.5 POWER SUPPLY (AWZ2241), CONNECT and TRANS CONNECT assembly

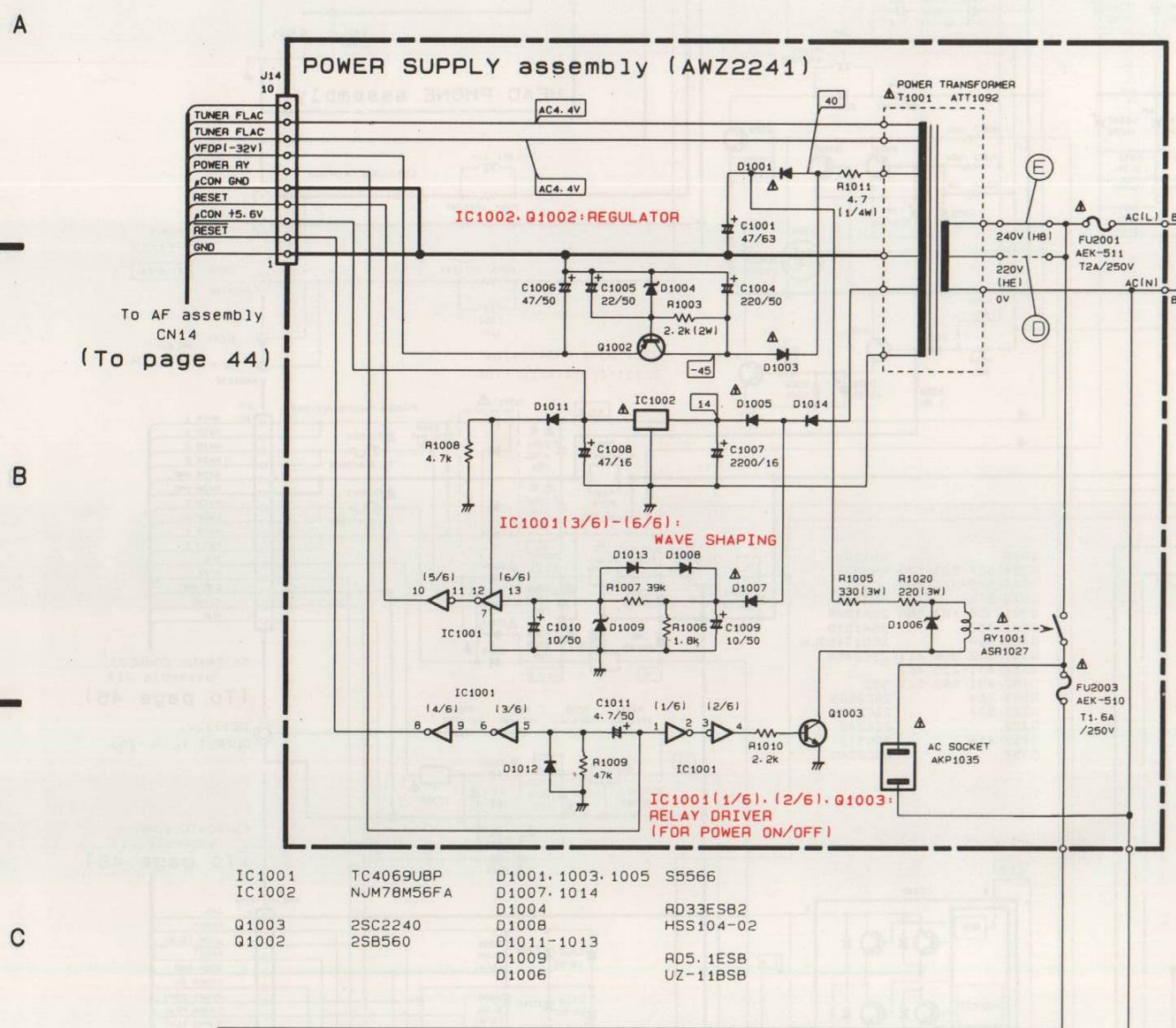

POWER SUPPLY assembly (AWZ2241)

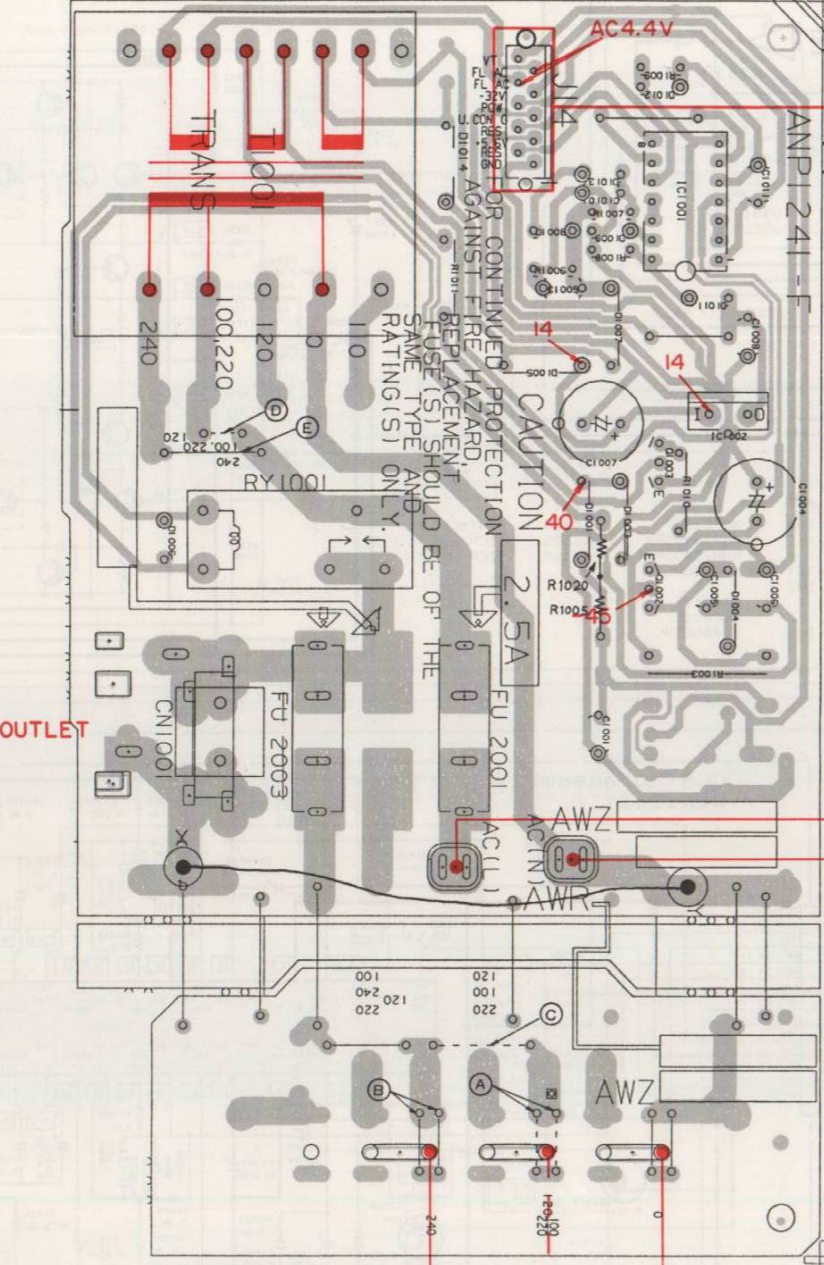

CONNECT assembly

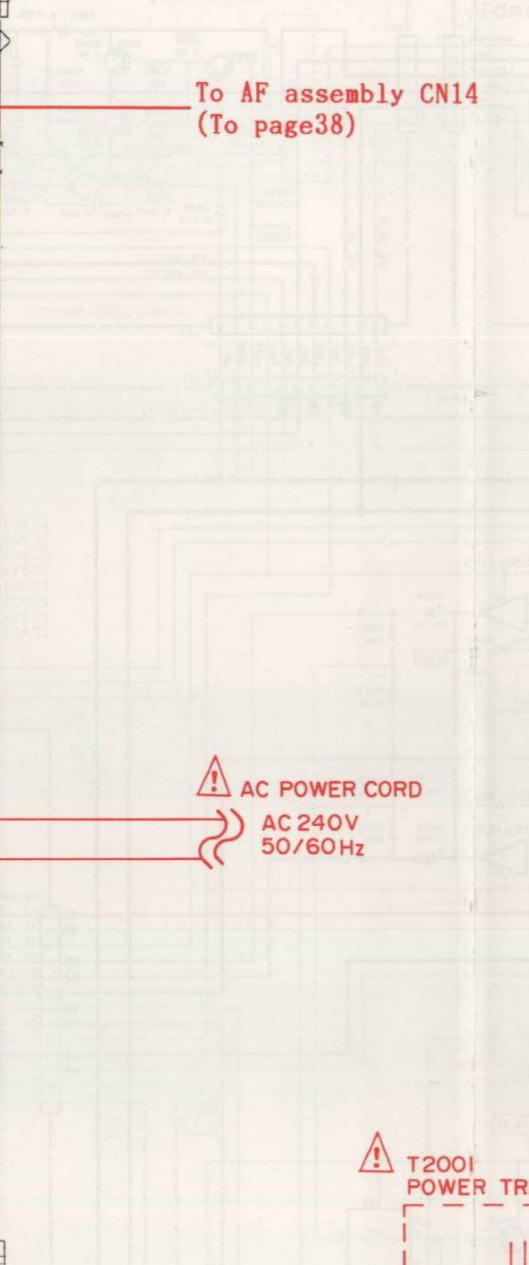

TRANS CONNECT assembly

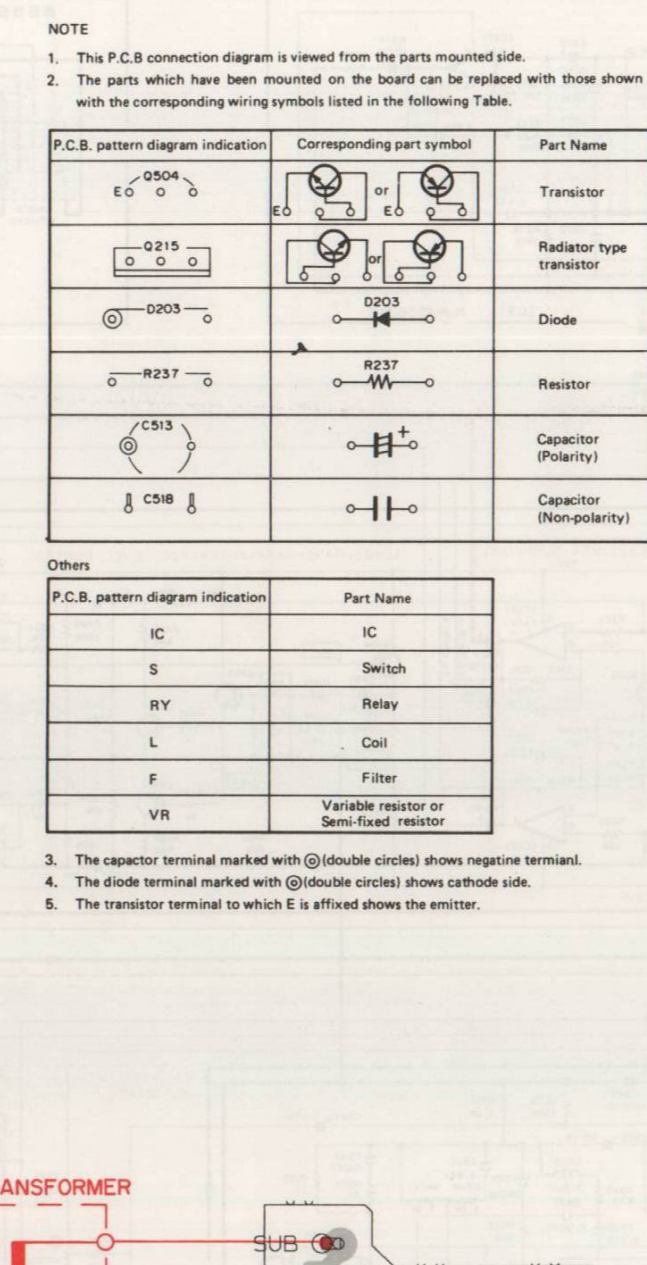

NOTE:
 1. This P.C.B connection diagram is viewed from the parts mounted side.
 2. The parts which have been mounted on the board can be replaced with those shown with the corresponding wiring symbols listed in the following Table.

P.C.B. pattern diagram indication	Corresponding part symbol	Part Name
Q504	Q504	Transistor
Q215	Q215	Radiator type transistor
D203	D203	Diode
R237	R237	Resistor
C513	C513	Capacitor (Polarity)
C518	C518	Capacitor (Non-polarity)

Others

P.C.B. pattern diagram indication	Part Name
IC	IC
S	Switch
RY	Relay
L	Coil
F	Filter
VR	Variable resistor or Semi-fixed resistor

3. The capacitor terminal marked with ⊖ (double circles) shows negative terminal.
 4. The diode terminal marked with ⊕ (double circles) shows cathode side.
 5. The transistor terminal to which E is affixed shows the emitter.

NOTE:
 This picture shows the foil side of the printed circuit.

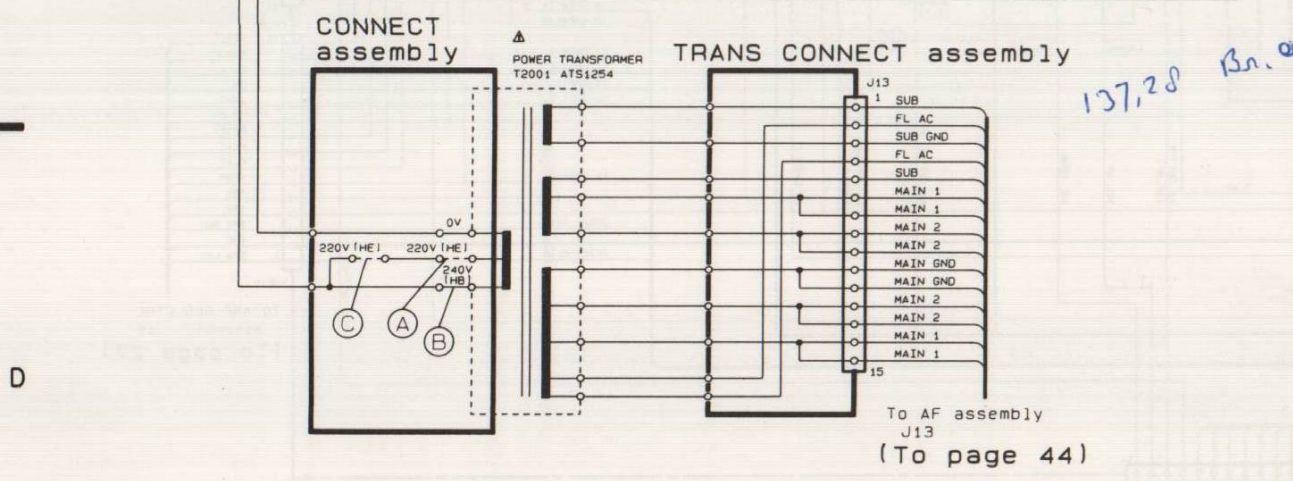
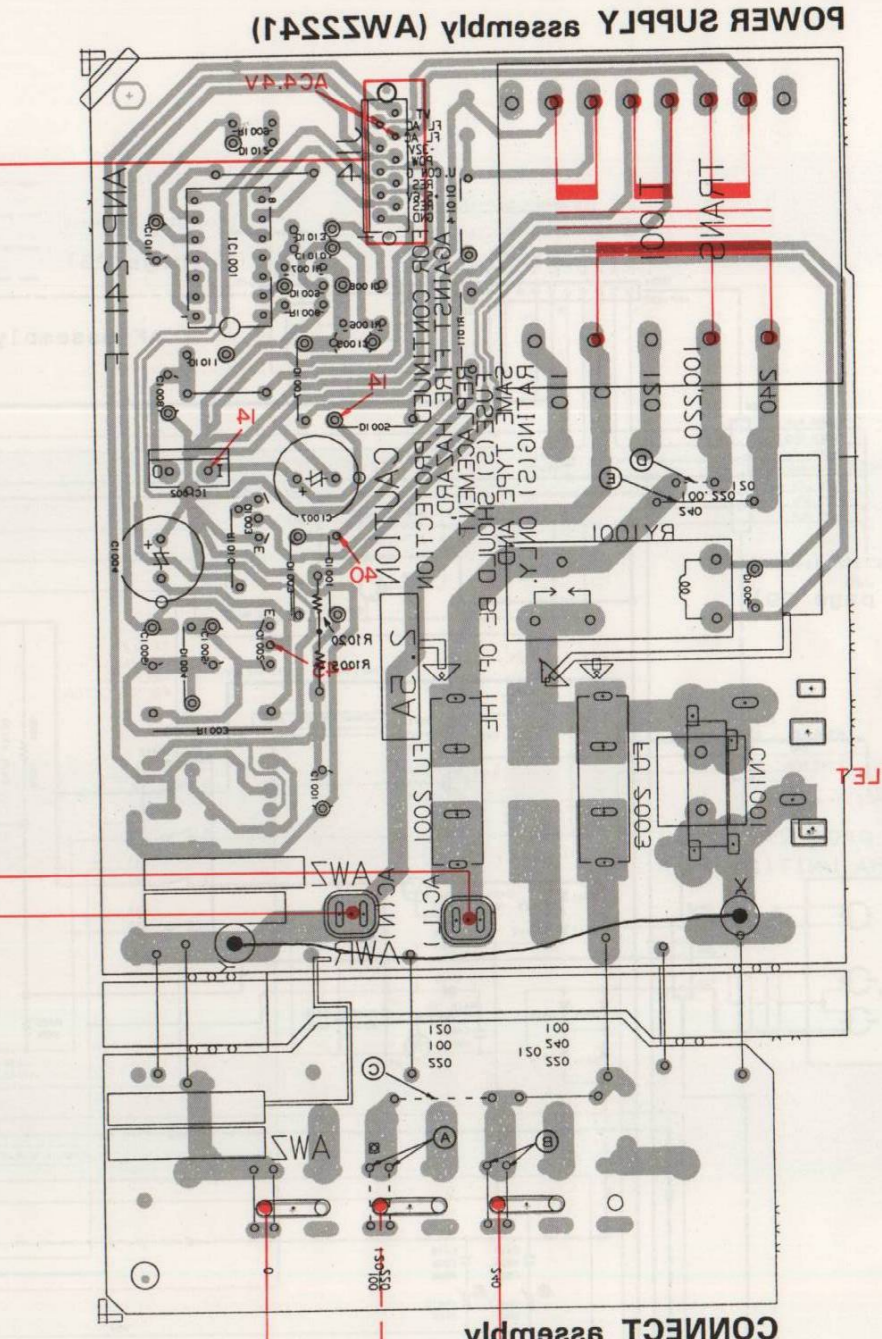

Line Voltage Selection (FOR HB AND HE TYPES)
 Line voltage can be changed with the following steps.
 1. Disconnect the AC power cord.
 2. Remove the top cover.
 3. Change the position of the jumper wires (A-E) as follows.

Jumper wire	220V(HE)	240V(HB)
(A)	○	○
(B)	×	×
(C)	○	×
(D)	○	×
(E)	×	○

○ : Be needed
 × : Be needless

Part No.	Description
AAX-193	220V label
AAX-192	240V label

To AF assembly CN13 (To page 38)

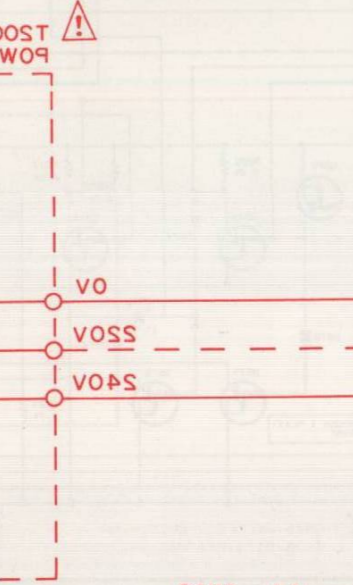
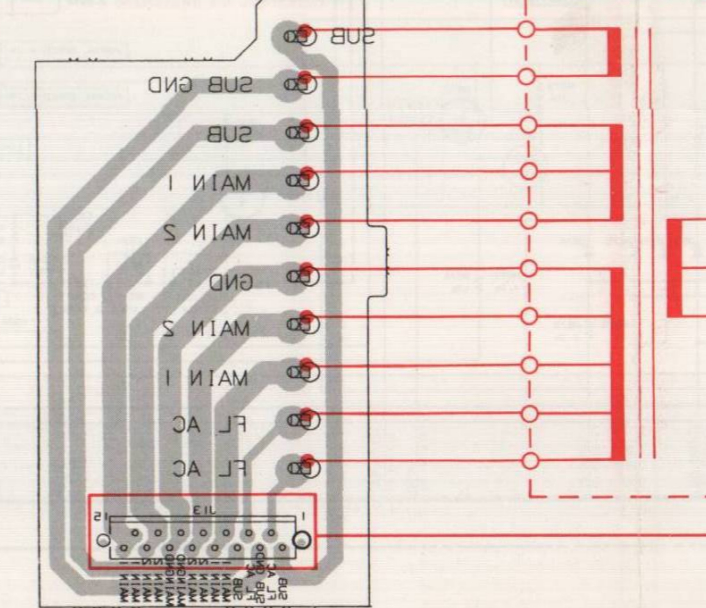
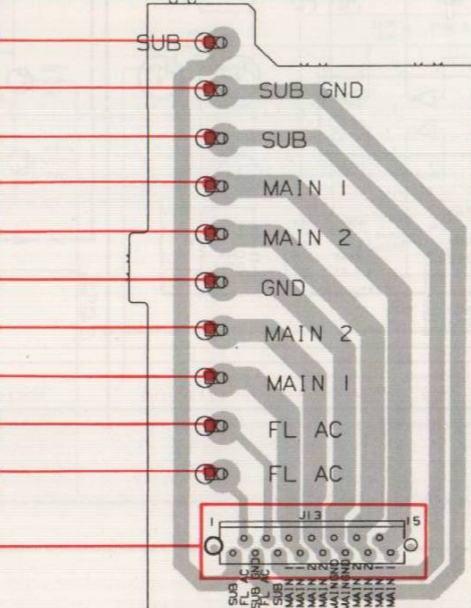
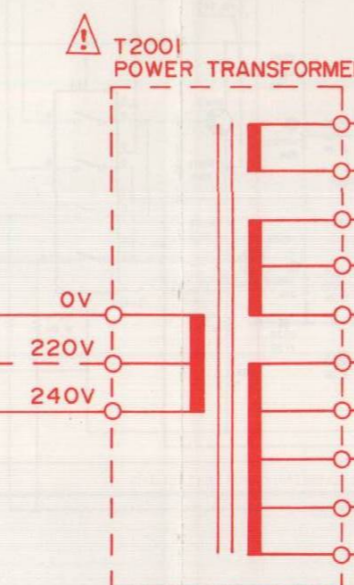

To AF assembly CN13 (To page 38)

Free service manuals
 Gratis schema's
 Digitized by
www.freeservicemanuals.info

5. P.C.B's PARTS LIST

NOTES:

- Parts without part number cannot be supplied.
- Parts marked by "●" are not always kept in stock. Their delivery time may be longer than usual or they may be unavailable.
- The Δ mark found on some component parts indicates the importance of the safety factor of the part. Therefore, when replacing, be sure to use parts of identical designation.
- When ordering resistors, first convert resistance values into code form as shown in the following examples.

Ex. 1 When there are 2 effective digits (any digit apart from 0), such as 560 ohm and 47k ohm (tolerance is shown by J = 5%, and K = 10%).

560 Ω	56 $\times 10^1$	561.....	RD1/4PS \square \square \square J
47k Ω	47 $\times 10^3$	473.....	RD1/4PS \square \square \square J
0.5 Ω	0R5.....		RN2H \square \square \square K
1 Ω	010.....		RS1P \square \square \square K

Ex. 2 When there are 3 effective digits (such as in high precision metal film resistors).

5.62k Ω	562 $\times 10^1$	5621.....	RN1/4SR \square \square \square F
----------------	-------------------	-----------	---

Mark No. Description Parts No.

SPEANA ASSEMBLY (AWG 1025)

SEMICONDUCTORS

IC721-725	OP-AMP IC	NJM4558DXP
IC726	OP-AMP IC	TC4051BP
Q721-729	TRANSISTOR	RN1201
Q730	TRANSISTOR	2SA1048
Q731-733	TRANSISTOR	2SC2458
D721-728	DIODE	HSS104-02

CAPACITORS

C721,722	CERAMIC CAPACITOR	CKDYX823M16
C723,724	CERAMIC CAPACITOR	CKCYX333M16
C725,726	CERAMIC CAPACITOR	CKCYX123M16
C727,728	CERAMIC CAPACITOR	CKCYB472K50
C729,730	CERAMIC CAPACITOR	CKCYB182K50
C731,732	CERAMIC CAPACITOR	CKCYB821K50
C733,734	CERAMIC CAPACITOR	CKCYB331K50
C735-741	CERAMIC CAPACITOR	CKDYF473Z50

RESISTORS

ALL RESISTORS RD1/8PM \square \square \square J

OTHER

CN30	KPE13
------	-------

FUNCTION ASSEMBLY (AWK 1174)

SEMICONDUCTORS

IC901	OP-AMP IC	NJM4558DXP
IC902	LOGIC IC	TC4052BP
IC903	LOGIC IC	TC4066BP
IC904	OP-AMP IC	NJM4558DXP
Q901	TRANSISTOR	DTA143ES
Q902	TRANSISTOR	DTC143ES
Q903	TRANSISTOR	DTA143ES
D901	DIODE	HSS104-02

Mark No. Description Parts No.

CAPACITORS

C903-906	CERAMIC CAPACITOR	CCCSL101J50
C907,908	ELECTR. CAPACITOR	CEAS2R2M50
C909,910	CERAMIC CAPACITOR	CKCYB152K50
C911,912	CERAMIC CAPACITOR	CKCYB562K50
C913,914	ELECTR. CAPACITOR	CEAS470M10
C919,920	ELECTR. CAPACITOR	CEAS100M25
C929,930	CERAMIC CAPACITOR	CCCSL101J50
C931,932	ELECTR. CAPACITOR	CEAS100M25

RESISTORS

ALL RESISTORS RD1/8PM \square \square \square J

OTHERS

JACK 4-P	AKB1009
JACK 4-P	AKB1085

AF ASSEMBLY (AWZ2630)

SEMICONDUCTORS

IC301		MC7812CT
IC302	REGULATOR IC	NJM78M05FA
IC303	REGULATOR IC	NJM79M05FA
IC304		MC7812CT
IC306	IC PROTECTOR	ICP-N38
IC309	IC PROTECTOR	ICP-N25
IC311,321	OP-AMP IC	NJM4558DXP
IC331	AUDIO IC	STK4192-2GP
IC332	NECHA UNICE IC	TA7291S
IC412	LOGIC IC	TC4066BP
IC431	OP-AMP IC	NJM4558DXP
IC501	OP-AMP IC	NJM4558DXP
IC521	LOGIC IC	TC4066BP
IC522	OP-AMP IC	NJM4558DXP
IC523	LOGIC IC	SN74LS05N
Q321	TRANSISTOR	2SA1048
Q322	N-FET	2SK246
Q351,352	TRANSISTOR	2SC2458

Mark	No.	Description	Parts No.	Mark	No.	Description	Parts No.
	C537,538	MYLOR FILM CAPACITOR	CQMA752J50			SPEAKER TERMINAL 4-P JACK	AKE1012 AKN-203
	C539,540	CERAMIC CAPACITOR	CKCYB562K50				
	C541,542	MYLOR FILM CAPACITOR	CQMA473J50		CN54	SOCKET 15-P GEQ ASSEMBLY REC ASSEMBLY DOLBY C ASSEMBLY	AKP1038 AWG1034 AWK1242 AWK1243
	C543,544	MYLOR FILM CAPACITOR	CQMA333J50				
	C545,564	ELECTR. CAPACITOR	CEAS470M16		CN14	JUMPER CONNECTOR 10-P	KPE10P
	C570	ELECTR. CAPACITOR	CEAS470M16		CN15	JUMPER CONNECTOR 8-P	KPE8
	C581	ELECTR. CAPACITOR	CEAS470M16		CN16	JUMPER CONNECTOR 14-P	KPE14
	C582	CERAMIC CAPACITOR	CKCYB103K50		CN17	JUMPER CONNECTOR 11-P	KPE11
	C583	MYLOR FILM CAPACITOR	CQMA153K50		CN18	JUMPER CONNECTOR 15-P	KPE15
	C584	CERAMIC CAPACITOR	CKCYB103K50		CN25	JUMPER CONNECTOR 4-P	KPC4
	C585	MYLOR FILM CAPACITOR	CQMA123K250		CN29	JUMPER CONNECTOR 7-P	KPE7
	C586	CERAMIC CAPACITOR	CKMYB681K50			GEQ ASSEMBLY (AWG1034)	
	C587	CERAMIC CAPACITOR	CKMYB221K50			Note : This GEQ assembly (AWG1034) is a part of AF assembly (AWZ2630)	
	C588	CQPA (2000P/630V)	ACE1020			SEMICONDUCTORS	
	C590	MYLOR FILM CAPACITOR	CQMA562K400		IC601,602	GEQ IC	LA3607
	C591	ELECTR. CAPACITOR	CEAS4R7M50		IC603	GEQ EVR IC	LC7522
	C593	ELECTR. CAPACITOR	CEAS101M16		IC604	OP-AMP IC	M5218L
					Q601	TRANSISTOR	RN1201
					Q602	TRANSISTOR	2SC2458
					Q603	TRANSISTOR	RN2204
					Q604,605	TRANSISTOR	2SC2603
					Q606	TRANSISTOR	2SA1515
					Q607,608	TRANSISTOR	2SC2458
					Q609	TRANSISTOR	RN2203
					D601,602	DIODE	HSS104-02
					D603	ZENER DIODE	HZS5ALL
					D604	ZENER DIODE	HZS7B2L
					D605	DIODE	HSS104-02
						CAPACITORS	
					C601,602	ELECTROLYTIC CAPACITOR	CEASR15M50
					C603,604	ELECTR. CAPACITOR	CEASR47M50
					C605,606	CERAMIC CAPACITOR	CKCYX683M25
					C607,608	ELECTROLYTIC CAPACIT	CEASR15M50
					C609,610	CERAMIC CAPACITOR	CKCYX273M25
					C611,612	CERAMIC CAPACITOR	CKCYX683M25
					C613,614	CERAMIC CAPACITOR	CGMYX103M16
					C615,616	CERAMIC CAPACITOR	CKCYX273M25
					C617,618	CERAMIC CAPACITOR	CGMYX472M25
					C619,620	CERAMIC CAPACITOR	CGMYX103M16
					C621,622	CERAMIC CAPACITOR	CGMYB182M50
					C623,624	CERAMIC CAPACITOR	CGMYX472M25
					C625,626	CERAMIC CAPACITOR	CKMYB681K50
					C627,628	CERAMIC CAPACITOR	CGMYB182M50
						OTHERS	
						PHONO JACK 2-P	AKB1039

RESISTORS

	VR411,412	VR	VRTM6V204
	VR451,425	VR	VRTM6H104
	VR453,454	VR	VRTM6H203
	VR521,522	VR (22K)	ACP1026
	R301-306	CARBONFILM RESISTOR	RD1/4 PM □□□ J
	R307,308	METAL OXIDE RESISTOR	RS2LMFR22J
	R337-340	CARBONFILM RESISTOR	RD1/4 PM222J
	R341	FUSIBLE RESISTOR	RFA1/4 PL471J
	R342	CARBONFILM RESISTOR	RD1/4 PMFL101J
	R343,344	CARBO NFILM RESISTOR	RD1/4 PM222J
	R345	CARBONFILM RESISTOR	RD1/4 PMFL101J
	R348,349	CARBON FILM RESISTOR	RD1/4 PMF100J
	R350-352	CARBON FILM RESISTOR	RD1/4 PMFL □□□ J
	R364	METAL OXIDE RESISTOR	RS2LMF821J
	R589,590	CARBON FILM RESISTOR	RD1/2 PM □□□ J
		OTHER RESISTOR	RD1/8 PM □□□ J

OTHERS

PHONO JACK 2-P AKB1039

Mark No.	Description	Parts No.
C629,630	CERAMIC CAPACITOR	CKCYB331K50
C631,632	ELECTR. CAPACITOR	CEAS2R2M50
C633,634	ELECTR. CAPACITOR	CEAS2R2M50
C635-637	CERAMIC CAPACITOR	CKCYF473Z50
C638	CERAMIC CAPACITOR	CCCSL101J50
C639	ELECTR. CAPACITOR	CEAS010M50
C640	CERAMIC CAPACITOR	CCCSL560J50
C641	ELECTR. CAPACITOR	CEAS0R1M50
C642	ELECTR. CAPACITOR	CEAS331M16
C643	ELECTR. CAPACITOR	CEAS100M25
C644,645	ELECTR. CAPACITOR	CEAS101M10

RESISTORS

R609,610	RESISTOR ARRAY (1M)	RA8T105J
	OTHER RESISTORS	RD1/8PM□□□J

OTHER

CN48	JAMPER CONNECTOR	KPE99 9P
------	------------------	-------------

REC ASSEMBLY (AWK1242)

Note : This REC assembly (AWK1242) is a part of AF assembly (AWZ2630)

SEMICONDUCTORS

IC1401		NJM4558DXP
Q1403,1404	TRANSISTOR	2SC2878
Q1405-1408	TRANSISTOR	RN1203
Q1409,1410	N-FET	2SK373
Q1411,1412	TRANSISTOR	2SC2458
Q1413	TRANSISTOR	RN1203
Q1414	TRANSISTOR	2SA1115
Q1415,1416	TRANSISTOR	2SA1515
Q1417,1418	TRANSISTOR	2SC2603
Q1420	TRANSISTOR	RN2203
Q1421	TRANSISTOR	RN1203
D1401-1409	DIODE	HSS104-02

COILS & TRANSFORMER

L1401,1402	COIL	ATM-037
L1403,1404	INDUCTOR	LTA392J
T1401	OSC TRANSFORMER	ATX-043

CAPACITORS

C1401,1402	ELECTR. CAPACITOR	CEAS010M50
C1403,1404	ELECTR. CAPACITOR	CEAS330M50
C1405,1406	MYLOR FILM CAPACITOR	CQMA473J50
C1407,1408	MYLOR FILM CAPACITOR	CQMA223J50

Mark No.	Description	Parts No.
C1409,1410	MYLOR FILM CAPACITOR	CQMA333J50
C1411	MYLOR FILM CAPACITOR	CQMA683J50
C1412,1413	CERAMIC CAPACITOR	CKCYB182K50
C1414	MYLOR FILM CAPACITOR	CQMA683J50
C1415,1416	ELECTR. CAPACITOR	CEAS470M10
C1417,1418	ELECTR. CAPACITOR	CEAS2R2M50
C1419,1420	CERAMIC CAPACITOR	CKMYB681K50
C1421,1422	CERAMIC CAPACITOR	CCMSL100D50
C1423,1424	ELECTR. CAPACITOR	CEAS470M16
C1425	CERAMIC CAPACITOR	CCCSL221J50
C1426	MYLOR FILM CAPACITOR	CQMA153J50
C1427	CERAMIC CAPACITOR	CKMYB681K50
C1428,1429	CERAMIC CAPACITOR	CKCYB103K50
C1430	MYLOR FILM CAPACITOR	CQMA123K250
C1431	CQPA (2000P/630V)	ACE1020
C1432	MYLOR FILM CAPACITOR	CQMA562K400
C1434,1435	CERAMIC CAPACITOR	CKCYB471K500
C1436	ELECTR. CAPACITOR	CEAS4R7M50
C1439	ELECTR. CAPACITOR	CEAS101M16
C1440,1441	MYLOR FILM CAPACITOR	CQMA332J50

RESISTORS

VR1401,1402	VR	VRTM6H203
VR1403,1404	VR	VRTM6H204
R1443,1444		RD1/2PM□□□J
	OTHER RESISTORS	RD1/8PM□□□J

DOLBY-C ASSEMBLY (AWK1243)

Note : This DOLBY-C assembly (AWK1243) is a part of AF assembly (AWZ2630)

SEMICONDUCTORS

IC1301		CX20187
Q1301	TRANSISTOR	RN2201
Q1302	TRANSISTOR	RN1201

COILS

F1301,1302		ATF1064
L1301,1302	INDUCTOR	LTA223J

CAPACITORS

C1301,1302	ELECTR. CAPACITOR	CEAS101M10
C1303,1304		CFTXA223J50
C1305,1306	ELECTR. CAPACITOR	CEAS100M25
C1307,1308	ELECTR. CAPACITOR	CEAS2R2M50

Mark No.	Description	Parts No.
C1309,1310	MYLOR FILM CAPACITOR	CQMA561J50
C1311,1312	MYLOR FILM CAPACITOR	CQMA332J50
C1313,1314	MYLOR FILM CAPACITOR	CQMA472J50
C1315,1316	ELECTR. CAPACITOR	CEASR47M50
C1317,1318	AUDIO FILM CAPACITOR	CFTXA154J50
C1319,1320	AUDIO FILM CAPACITOR	CFTXA153J50
C1321,1322	AUDIO FILM CAPACITOR	CFTXA224J50
C1323,1324	AUDIO FILM CAPACITOR	CFTXA683J50
C1325,1326	AUDIO FILM CAPACITOR	CFTXA473J50
C1327,1328	MYLOR FILM CAPACITOR	CQMA682J50
C1329,1330	AUDIO FILM CAPACITOR	CFTXA103J50
C1331,1332	ELECTR. CAPACITOR	CEAS100M25

RESISTORS

ALL RESISTORS RD1/8PM□□□J

MAIN VR ASSEMBLY**SEMICONDUCTORS**

IC391		NJM4558DXP
Q391,392	TRANSISTOR	2SC2878
Q393	TRANSISTOR	2SA1048

COILS

L391	AXIAL INDUCTOR	LAU5R6K
L392		

CAPACITORS

C391,392	ELECTR. CAPACITOR	CEAS4R7M50
C393,394	CERAMIC CAPACITOR	CCMSL101J50
C395,396	CERAMIC CAPACITOR	CKCYF473Z50
C397,398	ELECTR. CAPACITOR	CEAS470M10

RESISTORS

VR391	VR (100K×2)	ACX1021
	OTHER RESISTORS	RD1/8PM□□□J

HEAD PHONE ASSEMBLY**CAPACITOR**

C401	CERAMIC CAPACITOR	CKCYF473Z50
------	-------------------	-------------

Mark No.	Description	Parts No.
RESISTORS		

R401	CARBONFILM RESISTOR	RD1/8PM100J
	OTHER RESISTORS	RD1/2PME681J

OTHERS

CN26	JACK (HEAD PHONE) JUMPER CONNELTOR 5-P	AKN1010 KPC5
------	--	-----------------

TRANS CONNECT ASSEMBLY

No parts are supplied with the trans connect assembly.

BALANCE ASSEMBLY**RESISTOR**

VR372	(10K×2)	ACS1042
-------	---------	---------

MIC ASSEMBLY**SEMICONDUCTORS**

IC371	OP-AMP IC	NJM4558DXP
-------	-----------	------------

CAPACITORS

C371	CERAMIC CAPACITOR	CKCYF473Z50
C372	ELECTR. CAPACITOR	CEAS010M50
C373	CERAMIC CAPACITOR	CKMYB681K50
C375	ELECTR. CAPACITOR	CEAS100M25
C376	CERAMIC CAPACITOR	ACG1019A
C377	ELECTR. CAPACITOR	CEAS100M25
C379,380	CERAMIC CAPACITOR	CKCYF473Z50

RESISTORS

VR371	VARIABLE (10K-X1)	ACS1043
	OTHER REISTORS	RD1/8PM□□□J

OTHER

JACK MIC	AKN1017
----------	---------

DECK-1 SW ASSYEMBLY**SWITCHES**

S811-815	TACT SWITCH	ASG1029
----------	-------------	---------

DECK-2 SW ASSYEMBLY**SWITCHES**

S821-825	TACT SWITCH	ASG1029
----------	-------------	---------

6. ADJUSTMENTS

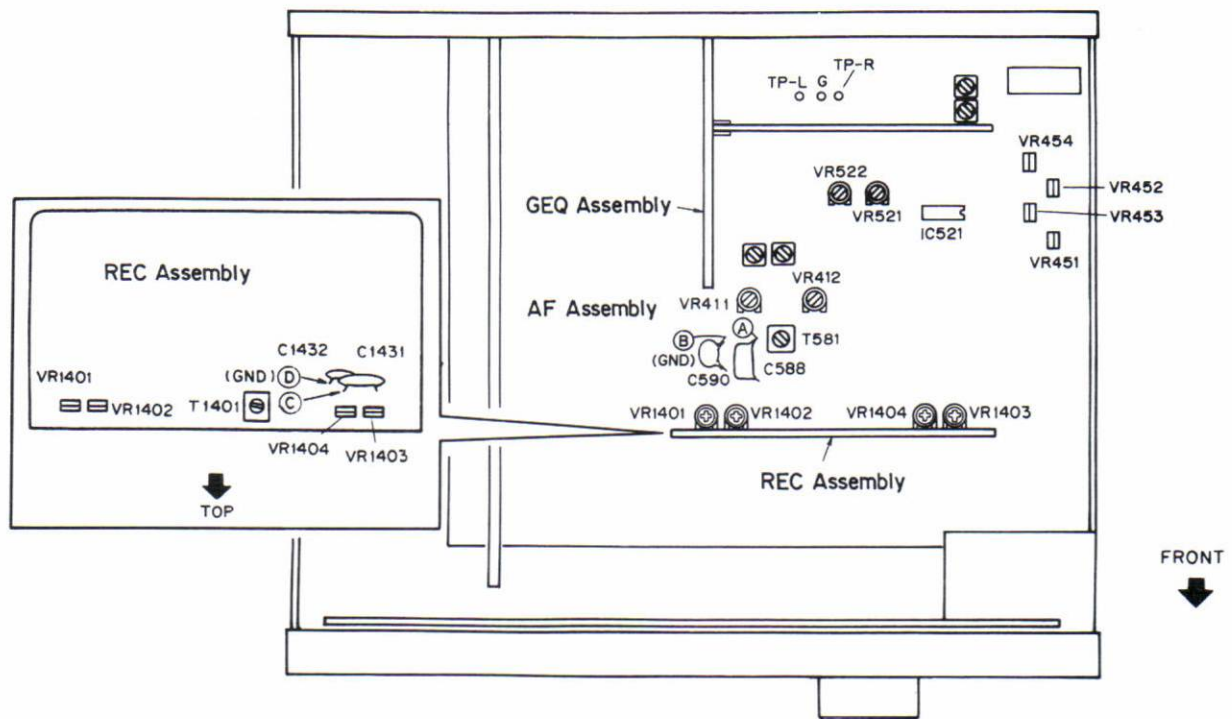

Fig 6.1. Adjustment location

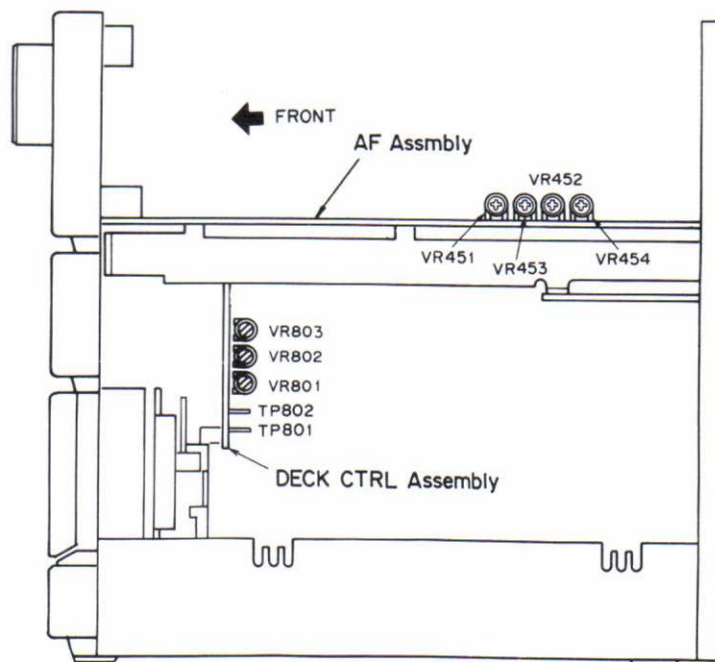

Fig 6.2. Adjustment location

Mark No.	Description	Parts No.
----------	-------------	-----------

DECK CENTER ASSEMBLY (AWZ2644)

SEMICONDUCTORS

Q822-825	TRANSISTOR	2SA1048
D841-844	LED	AEL1084
D845,846,848	LED (RED)	AEL1065
D850-852	LED	AEL1094
D853	LED (RED)	AEL1065
D854-859	DIODE	HSS104-2

SWITCHES

S848	SWITCH	ASH1011
S851-860	SWITCH	ASG1029
S862-864	SWITCH	ASG1029
S873	SWITCH	ASG1029
S849		ASH1014

RESISTORS

ALL REISTORS RD1/8PM□□□J

DECK CTRL ASSEMBLY (AWZ2645)

SEMICONDUCTORS

IC801		PDE033
IC802		SN74LS42N
Q801,802	TRANSISTOR	RN2204
Q803-806	TRANSISTOR	RN1201
Q807-812	TRANSISTOR	2SA1515
Q813-815	TRANSISTOR	RN1201
D801,802	DIODE	HSS104-02
D807-816	DIODE	HSS104-02
D820-826	DIODE	HSS104-02
D835-840	DIODE	HSS104-02

COIL

L801	AXIAL INDUCTOR	LAU220K
------	----------------	---------

CAPACITORS

C801	ELECTR. CAPACITOR	CEASR33M50
C802	ELECTR. CAPACITOR	CEAS101M16
C803	ELECTR. CAPACITOR	CEAS101M10
C804-807	CERAMIC CAPACITOR	CKDYF473Z50
C839-841	CERAMIC CAPACITOR	CKDYB102K50

RESISTORS

VR801,802	VR	VRTM6H203
VR803	VR	VRTM6H103
	OTHER RESISTORS	RD1/8PM□□□J

Mark No.	Description	Parts No.
----------	-------------	-----------

OTHERS

CN21,22		KPE14
CN45		KPE4
X801	CERAMIC RESONATOR (4.19MHz)	ASS1018

AMP,GEQ CTRL ASSEMBLY (AWZ2646)

SEMICONDUCTORS

IC701,702		SN74LS05N
IC703		TC4081BP
IC727		NJM4558DXP
IC771		PD3133-C
Q701,702	TRANSISTOR	RN2201
D707,711	LED (RED)	AEL1099
D713	LED	AEL1105
D715	LED (RED)	AEL1099
D716	LED	AEL1081
D718,722	LED (RED)	AEL1099
D725,726	DIODE	HSS104-02
D729	LED	AEL1081
D730	LED	AEL1104
D771-780	DIODE	HSS104-02
D782	DIODE	HSS104-02
D785,786	DIODE	HSS104-02

COIL

L771	AXIAL INDUCTOR	LAU220K
------	----------------	---------

SWITCHES

S707	SWITCH	ASG1029
S711	SWITCH	ASG1029
S713-718	SWITCH	ASG1029
S722	SWITCH	ASG1029
S771-793	SWITCH	ASG1029

CAPACITORS

C771,772	CERAMIC CAPACITOR	CKDYF473Z50-
C773	(47000 μ F/5.5V)	ACH1135
C774	CERAMIC CAPACITOR	CKDYF473Z50
C775	CERAMIC CAPACITOR	CKCYB102K50
C776	CERAMIC CAPACITOR	CKDYF473Z50
C777	ELECTR. CAPACITOR	CEAS100M50

RESISTORS

R899	CARBON FILM RESISTOR	RD1/2PM1R8J
	OTHER RESISTORS	RD1/8PM□□□J

Mark No.	Description	Parts No.
----------	-------------	-----------

OTHERS

V771	FL TUBE	AAV1071
V772	FL TUBE	AAV1069
X771		ASS1018

POWER SUPPLY ASSEMBLY (AWZ2241)

SEMICONDUCTORS

IC1001		TC4069UBP
IC1002		NJM78M56FA
Q1002	TRANSISTOR	2SB560
Q1003	TRANSISTOR	2SC2240
D1001,1003	DIODE	S5566
D1004	ZENER DIODE	RD33ESB2
D1005	DIODE	S5566
D1006	ZENER DIODE	UZ-11BSB
D1007	DIODE	S5566
D1008	DIODE	HSS104-02
D1009	ZENER DIODE	RD5.1ESB
D1011-1013	DIODE	HSS104-02
D1014	DIODE	S5566

RELAY

RY1001	RELAY	ASR1027
--------	-------	---------

TRANSFORMER

△ T1001	POWER TRANSFORMER	ATT1092
---------	-------------------	---------

CAPACITORS

C1001	ELECTROLYTIC CAPACITOR	CEAS470M63
C1004	ELECTR. CAPACITOR	CEAS221M50
C1005	ELECTROLYTIC CAPACITOR	CEHAQ220M50
C1006	ELECTR. CAPACITOR	CEAS470M50
C1007	ELECTR. CAPACITOR	CEAS222M16
C1008	ELECTR. CAPACITOR	CEAS470M16
C1009	ELECTR. CAPACITOR	CEAS100M50
C1010	ELECTR. CAPACITOR	CEAS100M50
C1011	ELECTR. CAPACITOR	CEAS4R7M50

RESISTORS

R1003	METAL OXIDE RESISTOR	RS2LMF222J
R1011	CARBON FILM RESISTOR	RD1/4PMFL4R7J
R1005		RS3PMFR331J
R1020		RS3PMFR221J
	OTHER RESISTORS	RD1/8PM□□□J

Mark No.	Description	Parts No.
----------	-------------	-----------

OTHER

△	AC SOCKET 1-P	AKP1035
---	---------------	---------

CONNECT ASSEMBLY

No parts are supplied with the CONNECT assembly.

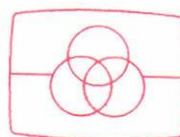

Free service manuals
Gratis schema's

Digitized by

www.freecservicemanuals.info

- Adjustment and measurement are usually made in the AF assembly, unless specified otherwise.
- Set the graphic equalizer to OFF, the BALANCE control knob to Center and the MIC LEVEL control knob to MIN.
- The function should always be set to "TAPE" unless otherwise specified.

Adjustment of Mechanical System

- Test tape: STD-301 (3 kHz 30 min)
- Setting of double speed mode: Short-circuit TP801 and TP802 of the DECK CTRL assembly To release the mode, break the short circuit.

1. Adjustment of tape speed							
No.	Mode	Input signal & Test tape	Adjustment location		Measuring location	Adjustment value	Remarks
1	PLAY	Playback the STD-301 tape to 3 kHz.	Deck I	DECK CTRL Assembly VR801	TP-L (Lch)	Press the PLAY SW and adjust the frequency to 3010 Hz \pm 10 Hz. Make sure that the wow and flutter is within 0.2 %.	
2	PLAY (Double speed mode)			—		Press the PLAY SW in double speed mode and confirm that the frequency is 6000 Hz \pm 1000 Hz. Note down the figure.	Release the double speed mode after adjustment.
3	PLAY (Double speed mode)		Deck II	DECK CTRL Assembly VR803	TP-R (Rch)	Press the PLAY SW in double speed mode and adjust the frequency to be within \pm 30 Hz of the figure recorded at step No. 2.	Release the double speed mode after adjustment.
4	PLAY			DECK CTRL Assembly VR802		Press the PLAY SW and adjust the frequency to 3010 Hz \pm 10 Hz. Make sure that the wow and flutter is within 0.2 %.	

Adjustment of Electric System

■ Check and conduct the following before adjusting the electric system.

1. Adjustment of tape speed has been completed.
2. Clean and demagnetize the head using a head eraser.
3. When measured, the level should be 0 dBV = 1 Vrms.
4. Use side A of the specified tape for adjustment.
STD-331B: For adjustment of playback system.
STD-630: NORMAL blank tape
5. Prepare the following measuring devices:
AC millivoltmeter, Low-frequency oscillator, Attenuator, Oscilloscope
6. Adjust both L and R channels, unless specified otherwise.
7. Set the DOLBY NR switches to OFF, unless specified otherwise.
8. Warm up the unit for several minutes before adjustment. Especially before adjusting the frequency characteristics of recording and playback, warm up for 3 to 5 minutes in REC/PLAY mode.
9. Make sure to follow the proper order of the adjustment procedure. Any change in the order may cause an imperfect result.

List of Adjustment

Deck I

1. Head azimuth adjustment
2. Playback level adjustment
3. Bias oscillation frequency adjustment
4. Recording level adjustment
5. Adjustment frequency characteristics of recording / playback

Deck II

1. Head azimuth adjustment
2. Playback level adjustment
3. Bias oscillation frequency adjustment
4. Recording level adjustment
5. Adjustment frequency characteristics of recording / playback

Checking of Decks I and II

1. Make sure the ALC is operating properly.

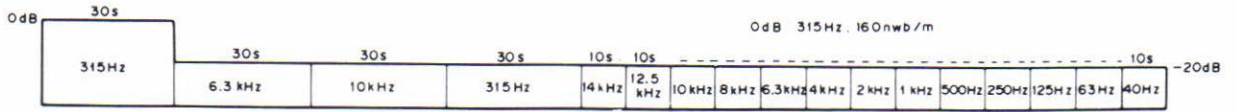

Fig. 6.3 Test tape STD-331B

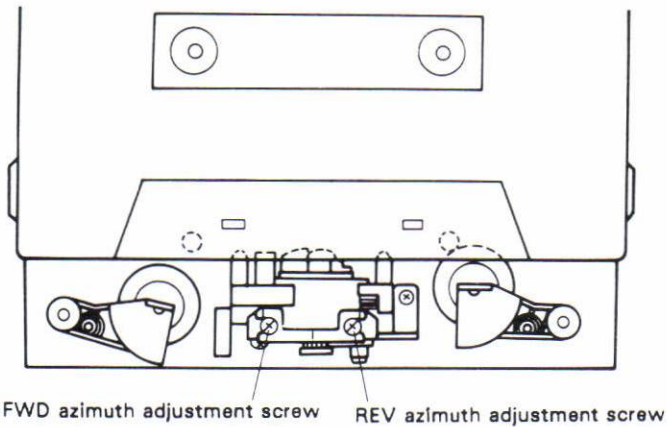

Fig. 6.4 Head azimuth adjustment

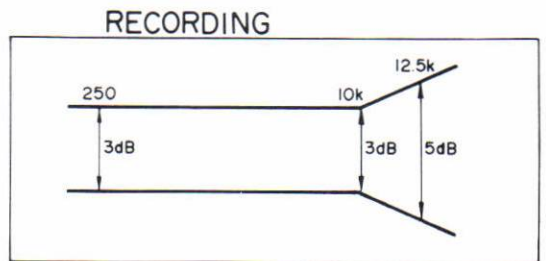
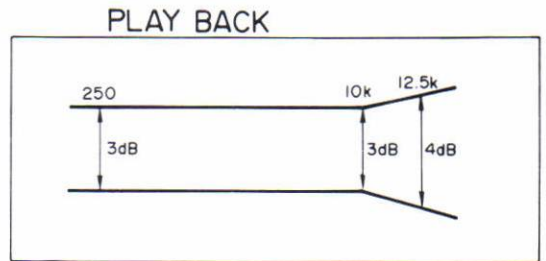

Fig. 6.5 Frequency characteristics

• **Head Adjustment of Deck I**

- Deck I is provided with an automatic tape selector mechanism.
- Note: Do not switch over FWD and REV while the driver is inserted.

1. Head Azimuth Adjustment

Pro-cedure	Tape selector	Mode	Input signal/test tape	Adjustment location	Measuring location	Adjustment value	Remarks
1	NORM	PLAY	Playback the test tape STD-331B (10 kHz, -20 dB).	Head azimuth adjustment screw (Fig. 6-4)	TP-L (Lch) TP-R (Rch)	Maximum playback signal level	Lock the screw with screw lock after completing adjustment.

2. Playback Level Adjustment

- Be sure to make a careful adjustment, as the adjustment determines the DOLBY NR level for playback.

Pro-cedure	Tape selector	Mode	Input signal/test tape	Adjustment location	Measuring location	Adjustment value	Remarks
1	NORM	PLAY	Playback the test tape STD-331B (315 Hz, 0 dB).	VR453 (Lch) VR454 (Rch)	TP-L (Lch) TP-R (Rch)	-10.3 dBV	

3. Bias oscillation frequency adjustment

Pro-cedure	Tape selector	Mode	Input signal/test tape	Adjustment location	Measuring location	Adjustment value	Remarks
1	NORM	REC	Load the test tape STD-630 and set to record mode.	T1401	Area between © and Ⓣ (REC Ass'y) shown in Fig. 6-1.	The oscillation frequency is 105 kHz \pm 1 kHz.	

4. Recording Level Adjustment

Pro-cedure	Tape selector	Mode	Input signal/test tape	Adjustment location	Measuring location	Adjustment value	Remarks
1	NORM	REC	Apply a signal of 315 Hz to the CD input terminal and set the function to "CD".	Input signal level	TP-L (Lch) TP-R (Rch)	-10.3 dBV	
2	NORM	REC/ PLAY	Record and playback the test tape STD-630 (315 Hz).	REC Assembly VR1401 (Lch) VR1402 (Rch)	TP-L (Lch) TP-R (Rch)	Repeat the recording and correction so that the playback level of 315 Hz is -10.3 dBV.	

5. Adjustment of frequency characteristics of recording/playback

- As this procedure is for adjustment of the recording bias, be careful not to increase the distortion by under-adjusting the bias.

Pro-cedure	Tape selector	Mode	Input signal/test tape	Adjustment location	Measuring location	Adjustment value	Remarks
1	NORM	REC	Apply a signal of 315 Hz to the CD input terminal and set the function to "CD".	Input signal level	TP-L (Lch) TP-R (Rch)	-30.3 dBV	
2	NORM	REC/ PLAY	Record and playback the test tape STD-630 (315 Hz and 10 kHz).	REC Assembly VR1403 (Lch) VR1404 (Rch)	TP-L (Lch) TP-R (Rch)	Repeat the correction so that the playback level of 10 kHz remains 0 \pm 0.5 dB in relation to 315 Hz.	

• Head Adjustment of Deck II

- Deck II is provided with an automatic tape selector mechanism.
- Note: Do not switch over FWD and REV while the driver is inserted.

1. Head Azimuth Adjustment

Pro-cedure	Tape selector	Mode	Input signal/test tape	Adjustment location	Measuring location	Adjustment value	Remarks
1	NORM	PLAY	Playback the test tape STD-331B (10 kHz, -20 dB).	Head azimuth adjustment screw (Fig. 6-4)	TP-L (Lch) TP-R (Rch)	Maximum playback signal level	Lock the screw with screw lock after completing adjustment.



2. Playback Level Adjustment

- Be sure to make a careful adjustment, as the adjustment determines the DOLBY NR level for playback.

Pro-cedure	Tape selector	Mode	Input signal/test tape	Adjustment location	Measuring location	Adjustment value	Remarks
1	NORM	PLAY	Playback the test tape STD-331B (315 Hz, 0 dB).	VR451 (Lch) VR452 (Rch)	TP-L (Lch) TP-R (Rch)	-10.3 dBV	

3. Bias oscillation frequency adjustment

Pro-cedure	Tape selector	Mode	Input signal/test tape	Adjustment location	Measuring location	Adjustment value	Remarks
1	NORM	REC	Load the test tape STD-630 and set to record mode.	T581	Area between ① and ② (AF Assembly) shown in Fig. 6-1.	The oscillation frequency is 105 kHz \pm 1 kHz.	

4. Recording Level Adjustment

Pro-cedure	Tape selector	Mode	Input signal/test tape	Adjustment location	Measuring location	Adjustment value	Remarks
1	NORM	REC	Apply a signal of 315 Hz to the CD input terminal and set the function to "CD".	Input signal level	TP-L (Lch) TP-R (Rch)	-10.3 dBV	
2	NORM	REC/ PLAY	Record and playback the test tape STD-630 (315 Hz).	VR521 (Lch) VR522 (Rch)	TP-L (Lch) TP-R (Rch)	Repeat the recording and correction so that the playback level of 315 Hz is -10.3 dBV.	

5. Adjustment of frequency characteristics of recording/playback

- As this procedure is for adjustment of the recording bias, be careful not to increase the distortion by under-adjusting the bias.

Pro-cedure	Tape selector	Mode	Input signal/test tape	Adjustment location	Measuring location	Adjustment value	Remarks
1	NORM	REC	Apply a signal of 315 Hz to the CD input terminal and set the function to "CD".	Input signal level	TP-L (Lch) TP-R (Rch)	-30.3 dBV	
2	NORM	REC/ PLAY	Record and playback the test tape STD-630 (315 Hz and 10 kHz).	VR411 (Lch) VR412 (Rch)	TP-L (Lch) TP-R (Rch)	Repeat the correction so that the playback level of 10 kHz remains 0 \pm 0.5 dB in relation to 315 Hz.	

• Checking Procedure for Decks I and II

1. Action of ALC

Pro-cedure	Tape selector	Mode	Input signal/test tape	Adjustment location	Measuring location	Checking value	Remarks
1	NORM	REC	Apply a signal of 315 Hz to the CD input terminal and set the function to "CD".	Input signal level	TP-L (Lch) TP-R (Rch)	-10.3 dBV	
2				+10 dB against the input level of step 1.		-5.5 dBV \pm 2.5 dB	

6. RÉGLAGE

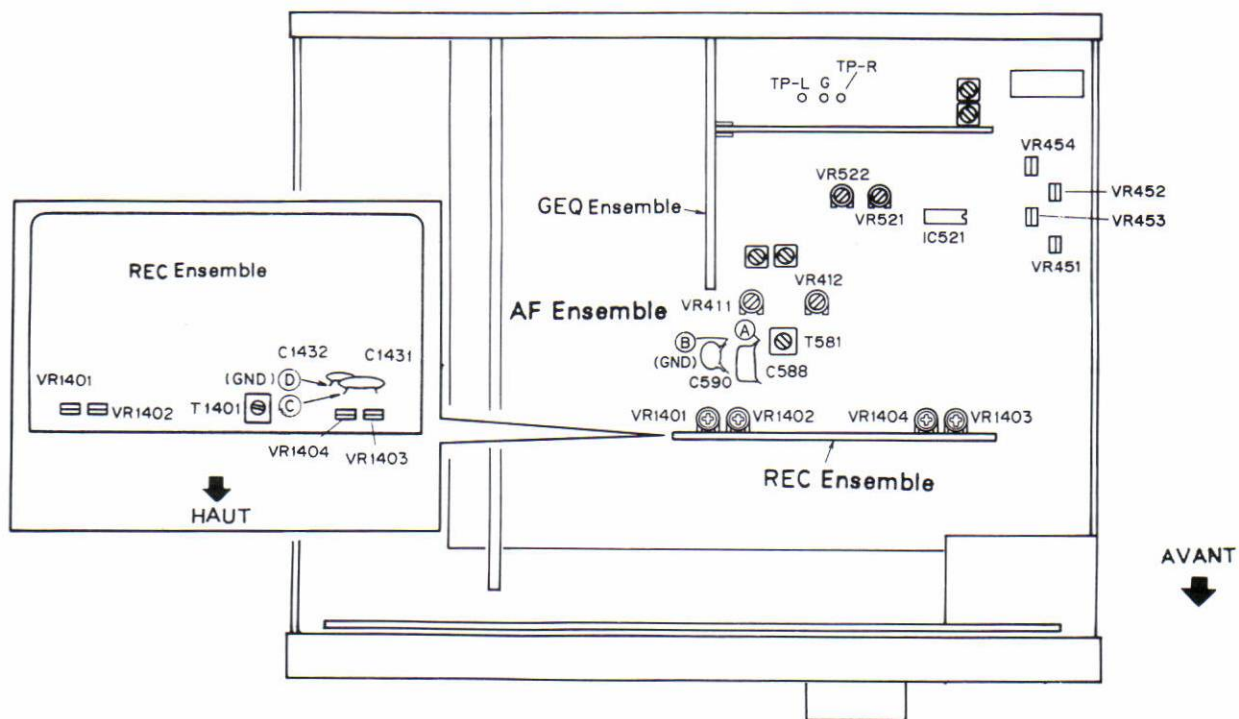

Fig 6.1 Points de réglage

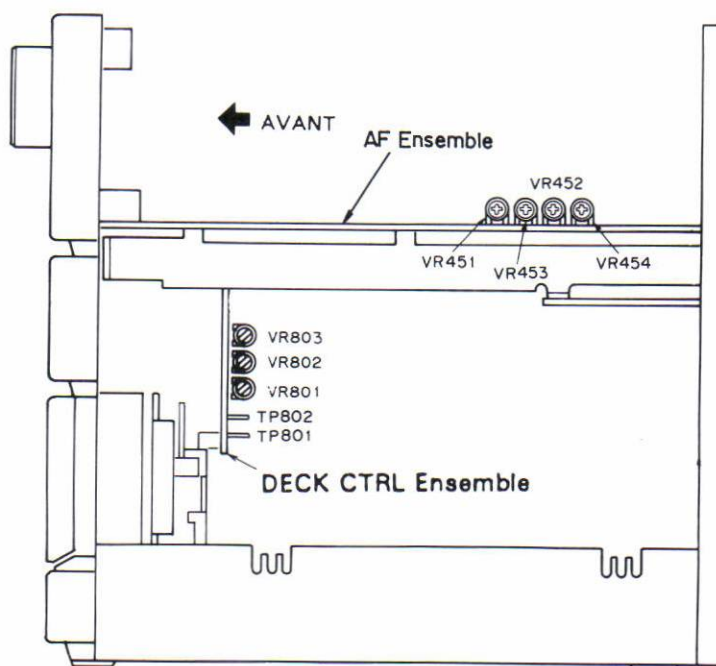

Fig 6.2 Points de réglage

- Les réglages et les mesures sont généralement faits dans l'ensemble AF, à moins de spécification contraire.
- Régler l'égaliseur graphique sur OFF, la commande d'équilibre (BALANCE) en position centrale et le volume de la commande de niveau microphone (MIC LEVEL) sur MIN.
- La fonction doit toujours être réglée sur "TAPE" à moins de spécification contraire.

Réglages mécaniques

- Bande d'étalonnage: STD-301 (3 kHz, 30 mn.)
- Réglage du mode de vitesse double: Court-circuiter TP801 et TP802 de l'ensemble de DECK CTRL. Pour libérer le mode, ouvrir le court-circuit.

1. Réglage de la vitesse de bande							
No.	Mode	Signal appliqué / bande d'étalonnage	Emplacement du réglage		Emplacement du point de mesure	Valeur relevée	Observations
1	PLAY	Reproduire la bande STD-301 par 3 kHz.	Platine I	ENSEMBLE COMM. PLATINE VR801	TP-L (can. G)	Appuyer sur le contacteur PLAY et régler la fréquence sur 3010 Hz \pm 10 Hz. Vérifier que le pleurage et scintillement est dans la limite de 0.2%.	
2	PLAY (Mode de vitesse double)			—		Appuyer sur le contacteur PLAY dans le mode de vitesse double et vérifier que la fréquence est 6000 Hz \pm 1000 Hz. Noter le chiffre.	Libérer le mode de vitesse double après le réglage.
3	PLAY (Mode de vitesse double)		Platine II	ENSEMBLE COMM. PLATINE VR803	TP-R (can. D)	Appuyer sur le contacteur PLAY dans le mode de vitesse double et régler la fréquence pour qu'elle soit dans la limite de \pm 30 Hz du chiffre noté dans l'étape No. 2.	Libérer le mode de vitesse double après le réglage.
4	PLAY			ENSEMBLE COMM. PLATINE VR802		Appuyer sur le contacteur PLAY et régler la fréquence sur 3010 Hz \pm 10 Hz. Vérifier que le pleurage et scintillement est dans la limite de 0.2%.	

Réglages électriques

■ Vérifier les points suivants et effectuer les opérations suivantes avant procéder aux réglages électriques.

1. Le réglage de la vitesse de bande a été complété.
2. Nettoyer et démagnétiser la tête avec un démagnétiseur de tête.
3. Lors de la mesure, le niveau doit être de 0 dBV = 1 V_{eff}.
4. Utiliser la face A de la bande spécifiée pour le réglage. STD-331B: Pour le réglage du système de lecture. STD-630: Bande vierge NORMAL
5. Préparer les instruments de mesure suivants: Millivoltmètre CA, oscillateur à basse fréquence, atténuateur et oscilloscope.
6. Régler les deux canaux L (gauche) et R (droit), sauf spécification contraire.
7. Régler les commutateurs DOLBY NR sur la position OFF, sauf spécification contraire.
8. Laisser chauffer l'appareil pendant plusieurs minutes avant le réglage. En particulier avant d'effectuer le réglage de la réponse en fréquence d'enregistrement et de lecture, laisser chauffer l'appareil pendant 3 à 5 minutes dans le mode d'enregistrement/lecture (REC/PLAY).

9. Toujours suivre l'ordre spécifié de la méthode réglage. Tout changement de l'ordre peut provoquer des résultats imparfaits.

Liste des réglages

Platine I

1. Azimut de la tête
2. Niveau de lecture
3. Réglage de fréquence d'oscillation de polarisation
4. Niveau d'enregistrement
5. Réponse en fréquence d'enregistrement / lecture

Platine II

1. Azimut de la tête
2. Niveau de lecture
3. Réglage de fréquence d'oscillation de polarisation
4. Niveau d'enregistrement
5. Réponse en fréquence d'enregistrement / lecture

Vérification des Platines I et II

1. Vérifier que le ALC fonctionne correctement.

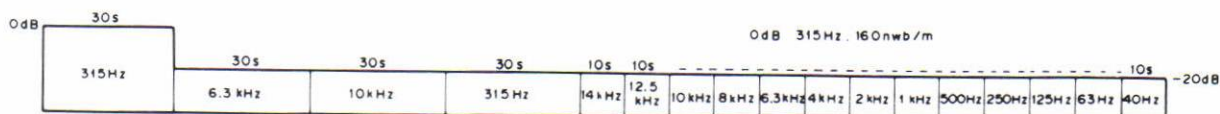

Fig. 6.3 Bande d'étalonnage STD-331B

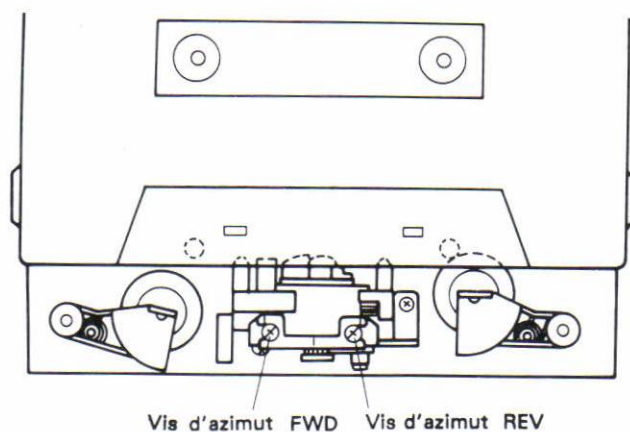
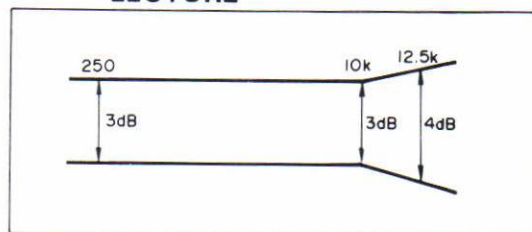

Fig. 6.4 Réglage d'azimut de la tête

LECTURE



ENREGISTREMENT

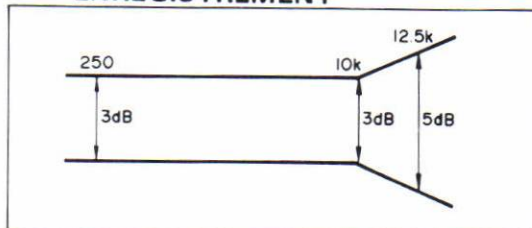

Fig. 6.5 Réponse en fréquence

• Réglage de la Platine I

- La Platine I est équipée d'un mécanisme de sélection automatique de bande.
- Remarque: Ne pas commuter entre le sens avant (FWD) et le sens arrière (REV) pendant que le tournevis est inséré.

1. Réglage d'azimut de la tête

Opération	Sélecteur de bande	Mode	Signal appliqué / bande d'étalonnage	Emplacement du réglage	Emplacement du point de mesure	Valeur mesurée	Observations
1	NORM	PLAY	Reproduire la bande d'étalonnage STD-331B (10 kHz, -20 dB).	Vis de réglage d'azimut de tête (Fig. 6-4)	TP-L (can. G) TP-R (can. D)	Niveau maximum du signal de lecture	Une fois le réglage terminé, bloquer la vis avec un frein de vis.

2. Réglage du niveau de lecture

- Toujours effectuer un réglage minutieux, car la valeur réglée sera le niveau Dolby pour la lecture.

Opération	Sélecteur de bande	Mode	Signal appliqué / bande d'étalonnage	Emplacement du réglage	Emplacement du point de mesure	Valeur mesurée	Observations
1	NORM	PLAY	Reproduire la bande d'étalonnage STD-331B (315 kHz, 0 dB)	VR453 (can. G) VR454 (can. D)	TP-L (can. G) TP-R (can. D)	-10.3 dBV	

3. Réglage de fréquence d'oscillation de polarisation

Opération	Sélecteur de bande	Mode	Signal appliqué / bande d'étalonnage	Emplacement du réglage	Emplacement du point de mesure	Valeur mesurée	Observations
1	NORM	REC	Charger la bande d'étalonnage STD-630 et régler dans le mode d'enregistrement.	T1401	Partie entre ③ et ④ (ensemble d'enregistrement (REC)) indiquée sur la Fig. 6-1.	La fréquence d'oscillation est de 105 kHz \pm 1 kHz.	

4. Réglage du niveau d'enregistrement

Opération	Sélecteur de bande	Mode	Signal appliqué / bande d'étalonnage	Emplacement du réglage	Emplacement du point de mesure	Valeur mesurée	Observations
1	NORM	REC	Appliquer un signal de 315 Hz à la borne d'entrée CD et régler la fonction sur "CD".	Niveau du signal d'entrée	TP-L (can. G) TP-R (can. D)	-10.3 dBV	
2	NORM	REC/ PLAY	Enregistrer et reproduire la bande d'étalonnage STD-630 (315 Hz).	Ensemble enr. (REC) VR1401 (can. G) VR1402 (can. D)	TP-L (can. G) TP-R (can. D)	Répéter l'enregistrement et la correction de sorte que le niveau de lecture de 315 Hz soit de -10.3 dBV.	

5. Réglage de la réponse fréquence d'enregistrement/lecture

- Cette opération réglant la polarisation d'enregistrement, faire attention de ne pas augmenter la distorsion par un réglage insuffisant de la polarisation.

Opération	Sélecteur de bande	Mode	Signal appliqué / bande d'étalonnage	Emplacement du réglage	Emplacement du point de mesure	Valeur mesurée	Observations
1	NORM	REC	Appliquer un signal de 315 Hz à la borne d'entrée CD et régler la fonction sur "CD".	Niveau du signal d'entrée	TP-L (can. G) TP-R (can. D)	-30.3 dBV	
2	NORM	REC/ PLAY	Enregistrer et reproduire la bande d'étalonnage STD-630 (315 Hz et 10 kHz).	Ensemble enr. (REC) VR1403 (can. G) VR1404 (can. D)	TP-L (can. G) TP-R (can. D)	Répéter la correction de sorte que le niveau de lecture de 10 kHz soit de 0 \pm 0.5 dB en relation avec 315 Hz.	

• Réglage de la Platine II

- La Platine II est équipée d'un mécanisme de sélection automatique de bande.
- Remarque: Ne pas commuter entre le sens avant (FWD) et le sens arrière (REV) pendant que le tournevis est inséré.

1. Réglage d'azimut de la tête

Opération	Sélecteur de bande	Mode	Signal appliqué / bande d'étalonnage	Emplacement du réglage	Emplacement du point de mesure	Valeur mesurée	Observations
1	NORM	PLAY	Reproduire la bande d'étalonnage STD-331B (10 kHz, -20 dB).	Vis de réglage d'azimut de tête (Fig. 6-4)	TP-L (can. G) TP-R (can. D)	Niveau maximum du signal de lecture	Une fois le réglage terminé, bloquer la vis avec un frein de vis.

2. Réglage du niveau de lecture

- Toujours effectuer un réglage minutieux, car la valeur réglée sera le niveau Dolby pour la lecture.

Opération	Sélecteur de bande	Mode	Signal appliqué / bande d'étalonnage	Emplacement du réglage	Emplacement du point de mesure	Valeur mesurée	Observations
1	NORM	PLAY	Reproduire la bande d'étalonnage STD-331B (315 kHz, 0 dB)	VR451 (can. G) VR452 (can. D)	TP-L (can. G) TP-R (can. D)	-10.3 dBV	

3. Réglage de fréquence d'oscillation de polarisation

Opération	Sélecteur de bande	Mode	Signal appliqué / bande d'étalonnage	Emplacement du réglage	Emplacement du point de mesure	Valeur mesurée	Observations
1	NORM	REC	Charger la bande d'étalonnage STD-630 et régler dans le mode d'enregistrement.	T581	Partie entre ① et ② (ensemble d'enregistrement (AF)) indiquée sur la Fig. 6-1.	La fréquence d'oscillation est de 105 kHz \pm 1 kHz.	

4. Réglage du niveau d'enregistrement

Opération	Sélecteur de bande	Mode	Signal appliqué / bande d'étalonnage	Emplacement du réglage	Emplacement du point de mesure	Valeur mesurée	Observations
1	NORM	REC	Appliquer un signal de 315 Hz à la borne d'entrée CD et régler la fonction sur "CD".	Niveau du signal d'entrée	TP-L (can. G) TP-R (can. D)	-10,3 dBV	
2	NORM	REC / PLAY	Enregistrer et reproduire la bande d'étalonnage STD-630 (315 Hz).	VR521 (can. G) VR522 (can. D)	TP-L (can. G) TP-R (can. D)	Répéter l'enregistrement et la correction de sorte que le niveau de lecture de 315 Hz soit de -10,3 dBV.	

5. Réglage de la réponse fréquence d'enregistrement/lecture

- Cette opération réglant la polarisation d'enregistrement, faire attention de ne pas augmenter la distorsion par un réglage insuffisant de la polarisation.

Opération	Sélecteur de bande	Mode	Signal appliqué / bande d'étalonnage	Emplacement du réglage	Emplacement du point de mesure	Valeur mesurée	Observations
1	NORM	REC	Appliquer un signal de 315 Hz à la borne d'entrée CD et régler la fonction sur "CD".	Niveau du signal d'entrée	TP-L (can. G) TP-R (can. D)	-30,3 dBV	
2	NORM	REC / PLAY	Enregistrer et reproduire la bande d'étalonnage STD-630 (315 Hz et 10 kHz).	VR411 (can. G) VR412 (can. D)	TP-L (can. G) TP-R (can. D)	Répéter la correction de sorte que le niveau de lecture de 10 kHz soit de 0 \pm 0,5 dB en relation avec 315 Hz.	

• Vérification de la Platines I et II

1. Action du ALC

Opération	Sélecteur de bande	Mode	Signal appliqué / bande d'étalonnage	Emplacement du réglage	Emplacement du point de mesure	Valeur mesurée	Observations
1	NORM	REC	Appliquer un signal de 315 Hz à la borne d'entrée CD et régler la fonction sur "CD".	Niveau du signal d'entrée	TP-L (can. G) TP-R (can. D)	-10,3 dBV	
2				+10 dB par rapport au niveau d'entrée de l'étape 1.		-5,5 dBV \pm 2,5 dB	

6. AJUSTE

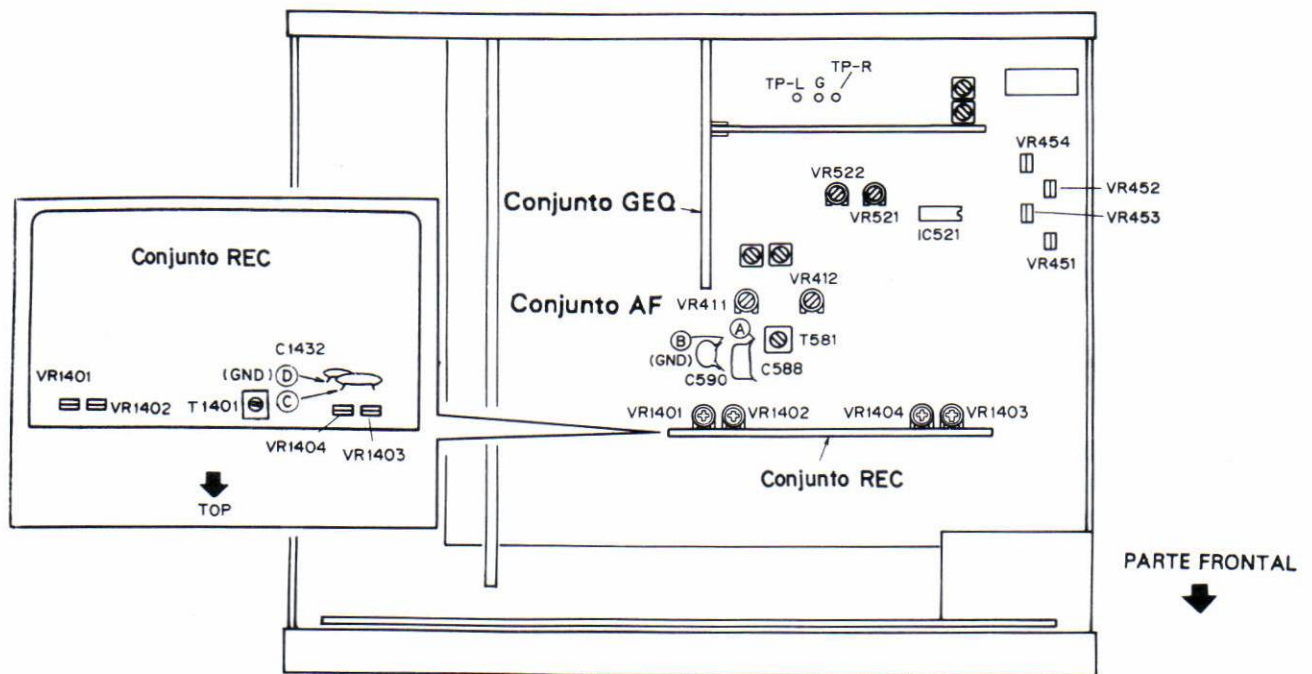

Fig 6.1 Punto de ajuste

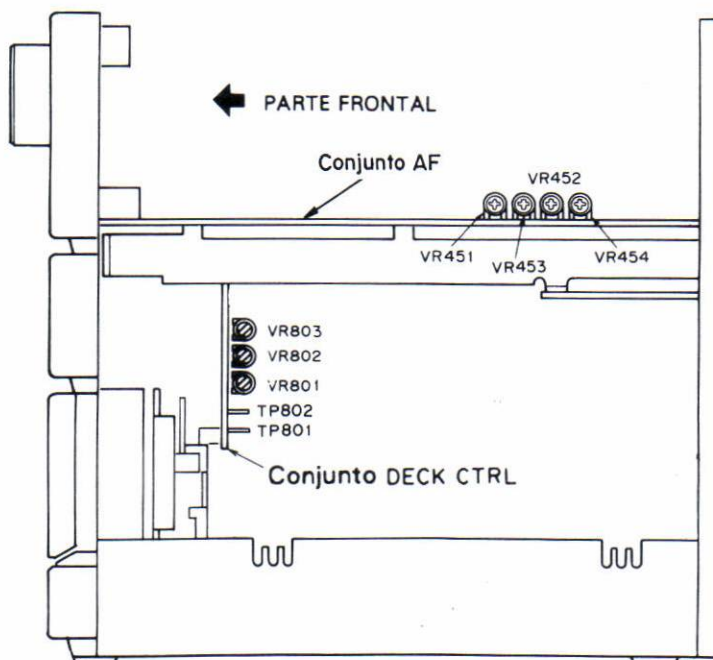

Fig 6.2 Punto de ajuste

- El ajuste y la medición se realizarán normalmente en el conjunto AF, a menos que se especifique otra cosa.
- Desactive (OFF) el ecualizador gráfico, ponga el control BALANCE en el centro, y ajuste el Control MIC LEVEL al mínimo (MIN).
- La función deberá estar ajustada siempre a "TAPE", a menos que se especifique otra cosa.

Ajuste del sistema mecánico

- Cinta de prueba: STD-301 (3 kHz, 30 min)
- Ajuste del modo de velocidad doble: Cortocircuite TP801 y TP802 del conjunto de DECK CTRL. Para desactivar el modo, abra el cortocircuito.

1. Ajuste de la velocidad de la cinta							
Nº	Modo	Señal de entrada/cinta de prueba	Punto de ajuste		Punto de medición	Valor de ajuste	Observaciones
1	PLAY	Reproducción de la cinta STDy301 a 3 kHz	Sección I	VR801 del conjunto DECK CTRL	TP-L (canal izquierdo)	Presione PLAY SW y ajuste la frecuencia a 3010 Hz \pm 10 Hz. Cerciórese de que la fluctuación y el efecto de trémolo estén dentro de los límites del 0.2%.	
2	PLAY (Modo de velocidad doble)			—		Presione PLAY SW en el modo de velocidad doble y compruebe si la frecuencia es 6000 Hz \pm 1000 Hz. Anote el valor.	Después del ajuste, desactive el modo de velocidad doble.
3	PLAY (Modo de velocidad doble)		Sección II	VR803 del conjunto DECK CTRL	TP-R (canal derecho)	Presione PLAY SW en el modo de velocidad doble y ajuste la frecuencia de forma que quede a \pm 30 Hz del valor anotado en el paso N°2.	Después del ajuste, desactive el modo de velocidad doble.
4	PLAY			VR802 del conjunto DECK CTRL		Presione PLAY SW y ajuste la frecuencia a 3010 Hz \pm 10 Hz. Cerciórese de que la fluctuación y el efecto de trémolo estén dentro de los límites del 0.2%.	

Ajuste del sistema eléctrico

■ Antes de ajustar el sistema eléctrico, compruebe y realice lo siguiente.

1. El ajuste de la velocidad de la cinta ha finalizado.
2. Limpie y desmagnetice la cabeza empleando un desmagnetizador de cabezas.
3. Cuando se mida, el nivel de nivel debe ser de 0 dBV = 1V rms.
4. Emplee el lado A de la cinta especificada para realizar el ajuste.
STD-331B: Para ajuste del sistema de reproducción.
STD-630: Cinta en blanco NORMAL
5. Prepare los dispositivos de medición siguientes: Milivoltímetro de CA, oscilador de baja frecuencia, atenuador, y osciloscopio
6. Ajuste ambos canales, izquierdo y derecho, a menos que se especifique otra cosa.
7. Ponga los interruptores DOLBY NR en OFF, a menos que se especifique otra cosa.
8. Antes del ajuste, deje que la unidad se caliente durante varios minutos.
Especialmente antes de ajustar las características de frecuencia de grabación y reproducción, deje que se caliente durante 3 a 5 minutos en el modo REC/PLAY.

9. Cerciórese de seguir el orden apropiado del procedimiento de ajuste. Cualquier cambio en el orden podría causar un resultado imperfecto.

Lista de ajuste

Sección I

1. Azimut de la cabeza
2. Nivel de reproducción
3. Ajuste de la frecuencia de oscilación de polarización
4. Nivel de grabación
5. Características de frecuencia de grabación/reproducción

Sección II

1. Azimut de la cabeza
2. Nivel de reproducción
3. Ajuste de la frecuencia de oscilación de polarización
4. Nivel de grabación
5. Características de frecuencia de grabación/reproducción

Comprobación de la secciones I y II

1. Cerciórese de que ALC esté funcionando adecuadamente.

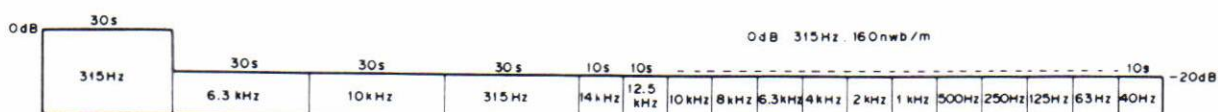

Fig. 6.3 Cinta de prueba STD-331B

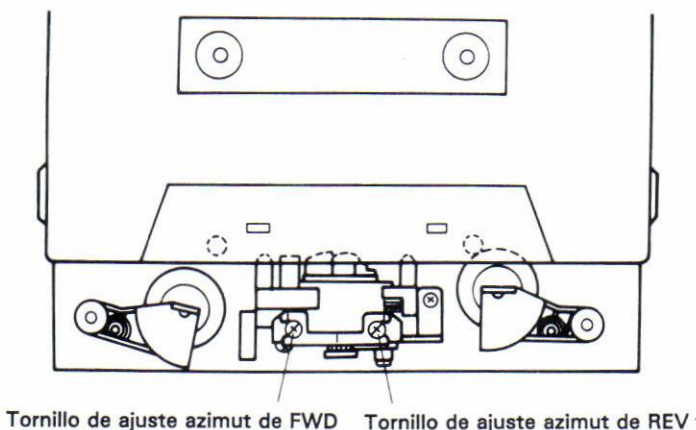

Fig. 6.4 Ajuste del azimut de la cabeza

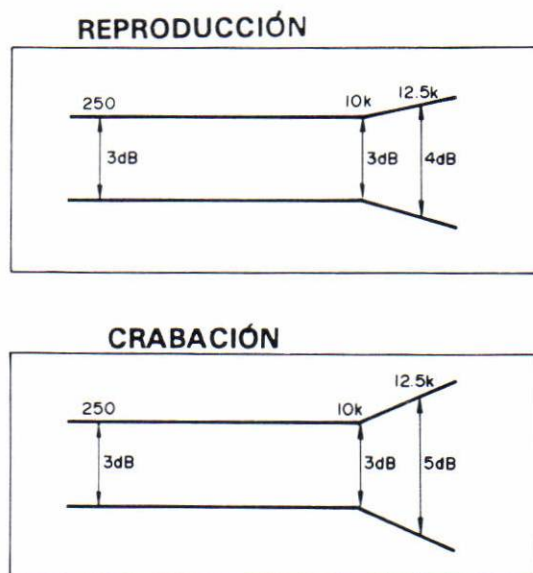

Fig. 6.5 Características de frecuencia

• **Ajuste de la sección I**

- La sección I dispone de un mecanismo selector automático de cinta.
- Nota: No cambie a FWD ni a REV mientras el destornillador esté insertado.

1. Ajuste azimutal de la cabeza

Procedimiento	Selector de cinta	Modo	Señal de entrada / cinta de prueba	Punto de ajuste	Punto de medición	Valor de ajuste	Observaciones
1	NORM	PLAY	Ponga la cinta de prueba STD-331B en reproducción (10 kHz, -20 dB).	Tornillo de ajuste azimutal de la cabeza (Fig. 6-4)	TP-L (canal izquierdo) TP-R (canal derecho)	Nivel máximo de la señal de reproducción	Bloquee el tornillo con bloqueador de tornillos después de haber terminado el ajuste.

2. Ajuste del nivel de reproducción

- Tenga mucho cuidado durante el ajuste, ya que el valor ajustado será el nivel Dolby fijado para reproducción.

Procedimiento	Selector de cinta	Modo	Señal de entrada / cinta de prueba	Punto de ajuste	Punto de medición	Valor de ajuste	Observaciones
1	NORM	PLAY	Ponga la cinta de prueba STD-331B en reproducción (315 Hz, 0 dB).	VR453 (canal izquierdo) VR454 (canal derecho)	TP-L (canal izquierdo) TP-R (canal derecho)	-10.3 dBV	

3. Ajuste de la frecuencia de oscilación de polarización

Procedimiento	Selector de cinta	Modo	Señal de entrada / cinta de prueba	Punto de ajuste	Punto de medición	Valor de ajuste	Observaciones
1	NORM	REC	Cargue la cinta de prueba STD-630 y establezca el modo de grabación.	T1401	Área entre © y Ⓣ (conjunto de REC) mostrada en la Fig. 6-1.	La frecuencia de oscilación es de 105 kHz ± 1 kHz.	

4. Ajuste del nivel de grabación

Procedimiento	Selector de cinta	Modo	Señal de entrada / cinta de prueba	Punto de ajuste	Punto de medición	Valor de ajuste	Observaciones
1	NORM	REC	Aplique una señal de 315 Hz al terminal de entrada CD y ajuste la función a "CD".	Nivel de la señal de entrada	TP-L (canal izquierdo) TP-R (canal derecho)	-10.3 dBV	
2	NORM	REC / PLAY	Grabe y reproduzca la cinta de prueba STD-630 (315 Hz).	Conjunto REC VR1401 (canal izquierdo) VR1402 (canal derecho)	TP-L (canal izquierdo) TP-R (canal derecho)	Grabe y reproduzca la cinta de prueba de forma que el nivel de reproducción de 315 Hz sea de -10.3 dBV.	

5. Ajuste de las características de frecuencia de grabación/reproducción

- Como este procedimiento es para el ajuste de la polarización de grabación, tenga cuidado de no aumentar el valor de distorsión mediante el subajuste de la polarización.

Procedimiento	Selector de cinta	Modo	Señal de entrada / cinta de prueba	Punto de ajuste	Punto de medición	Valor de ajuste	Observaciones
1	NORM	REC	Aplique una señal de 315 Hz al terminal de entrada CD y ajuste la función a "CD".	Nivel de la señal de entrada	TP-L (canal izquierdo) TP-R (canal derecho)	-30.3 dBV	
2	NORM	REC / PLAY	Grabe y reproduzca la cinta de prueba STD-630 (315 Hz y 10 kHz).	Conjunto REC VR1403 (canal izquierdo) VR1404 (canal derecho)	TP-L (canal izquierdo) TP-R (canal derecho)	Repita la corrección de forma que el nivel de reproducción de 10 kHz sea de 0 ± 0.5 dB en relación con 315 Hz.	

• Ajuste de la sección II

- La sección II dispone de un mecanismo selector automático de cinta.
- Nota: No cambie a FWD ni a REV mientras el destornillador esté insertado.

1. Ajuste azimutal de la cabeza

Procedimiento	Selector de cinta	Modo	Señal de entrada / cinta de prueba	Punto de ajuste	Punto de medición	Valor de ajuste	Observaciones
1	NORM	PLAY	Ponga la cinta de prueba STD-331B en reproducción (10 kHz, -20 dB).	Tornillo de ajuste azimutal de la cabeza (Fig. 6-4)	TP-L (canal izquierdo) TP-R (canal derecho)	Nivel máximo de la señal de reproducción	Bloquee el tornillo con bloqueador de tornillos después de haber terminado el ajuste.

2. Ajuste del nivel de reproducción

- Tenga mucho cuidado durante el ajuste, ya que el valor ajustado será el nivel Dolby fijado para reproducción.

Procedimiento	Selector de cinta	Modo	Señal de entrada / cinta de prueba	Punto de ajuste	Punto de medición	Valor de ajuste	Observaciones
1	NORM	PLAY	Ponga la cinta de prueba STD-331B en reproducción (315 Hz, 0 dB).	VR451 (canal izquierdo) VR452 (canal derecho)	TP-L (canal izquierdo) TP-R (canal derecho)	-10.3 dBV	

3. Ajuste de la frecuencia de oscilación de polarización

Procedimiento	Selector de cinta	Modo	Señal de entrada / cinta de prueba	Punto de ajuste	Punto de medición	Valor de ajuste	Observaciones
1	NORM	REC	Cargue la cinta de prueba STD-630 y establezca el modo de grabación.	T581	Área entre ④ y ⑤ (conjunto de AF) mostrada en la Fig. 6-1.	La frecuencia de oscilación es de 105 kHz \pm 1 kHz.	

4. Ajuste del nivel de grabación

Procedimiento	Selector de cinta	Modo	Señal de entrada / cinta de prueba	Punto de ajuste	Punto de medición	Valor de ajuste	Observaciones
1	NORM	REC	Aplique una señal de 315 Hz al terminal de entrada CD y ajuste la función a "CD".	Nivel de la señal de entrada	TP-L (canal izquierdo) TP-R (canal derecho)	-10.3 dBV	
2	NORM	REC / PLAY	Grabe y reproduzca la cinta de prueba STD-630 (315 Hz).	VR521 (canal izquierdo) VR522 (canal derecho)	TP-L (canal izquierdo) TP-R (canal derecho)	Grabe y reproduzca la cinta de prueba de forma que el nivel de reproducción de 315 Hz sea de -10.3 dBV.	

5. Ajuste de las características de frecuencia de grabación/reproducción

- Como este procedimiento es para el ajuste de la polarización de grabación, tenga cuidado de no aumentar el valor de distorsión mediante el subajuste de la polarización.

Procedimiento	Selector de cinta	Modo	Señal de entrada / cinta de prueba	Punto de ajuste	Punto de medición	Valor de ajuste	Observaciones
1	NORM	REC	Aplique una señal de 315 Hz al terminal de entrada CD y ajuste la función a "CD".	Nivel de la señal de entrada	TP-L (canal izquierdo) TP-R (canal derecho)	-30.3 dBV	
2	NORM	REC / PLAY	Grabe y reproduzca la cinta de prueba STD-630 (315 Hz y 10 kHz).	VR411 (canal izquierdo) VR412 (canal derecho)	TP-L (canal izquierdo) TP-R (canal derecho)	Repita la corrección de forma que el nivel de reproducción de 10 kHz sea de 0 ± 0.5 dB en relación con 315 Hz.	

• Procedimiento de comprobación para secciones I y II

1. Acción del ALC

Procedimiento	Selector de cinta	Modo	Señal de entrada / cinta de prueba	Punto de ajuste	Punto de medición	Valor de ajuste	Observaciones
1	NORM	REC	Aplique una señal de 315 Hz al terminal de entrada CD y ajuste la función a "CD".	Nivel de la señal de entrada	TP-L (canal izquierdo) TP-R (canal derecho)	-10.3 dBV	
2				+10 dB contra el nivel de entrada del paso 1.		-5.5 dBV \pm 2.5 dB	

7. IC INFORMATION

• Terminal function of PDE033 (DECK Control Micro Computer)

Note: I: CMOS input, N: Nch.open drain output,

O: CMOS output, UN: Nch.open drain output with pull-up MOS Transistor.

NO	Terminal Name	I/O	Function	Active																						
1	S1 (DATA1)	N	These pins are used to send data to or receive data from the TUNER micro computer.	H/L																						
2	S0 (DATA2)	O		H/L																						
3	SC	O		H/L																						
4	SREQ	O	Not used.	—																						
5	FADER (LED)	O	Thin pin activates the LED during FADER RECORDING.	H																						
6	1 BIAS	O	Thin pin oscillates the bias voltage only in the 1 mechanism RECORD mode.	H																						
7	2 BIAS	O	Thin pin oscillates the bias voltage only in the 2 mechanism RECORD mode.	H																						
8	TRCH	I	A "L" pulse having a 22 – 28.6msec width is input from the CD player when the CD player has detected an interval between tunes during track search.	L																						
9	COPY	UN	These pins select the status of the Dolby IC1301 and that of input switching of rec.amplifier IC521, according to the operational status of the REC and COPY, and the function.	H/L																						
10	Dolby P/R	UN	<table border="1"> <thead> <tr> <th>FUNCTION</th> <th>REC MODE</th> <th>COPY (PIN 9)</th> <th>DOLBY P/R (PIN 10)</th> </tr> </thead> <tbody> <tr> <td rowspan="2">TAPE</td> <td>NOT RECORDING</td> <td>L</td> <td>L</td> </tr> <tr> <td>RECORDING</td> <td>H</td> <td>L</td> </tr> <tr> <td rowspan="2">OTHERS</td> <td>NOT RECORDING</td> <td>L</td> <td>L</td> </tr> <tr> <td>RECORDING</td> <td>L</td> <td>H</td> </tr> <tr> <td></td> <td>DUBBING copy (AT STANDARD AND DOUBLE SPEED)</td> <td>L</td> <td>L</td> </tr> </tbody> </table>	FUNCTION	REC MODE	COPY (PIN 9)	DOLBY P/R (PIN 10)	TAPE	NOT RECORDING	L	L	RECORDING	H	L	OTHERS	NOT RECORDING	L	L	RECORDING	L	H		DUBBING copy (AT STANDARD AND DOUBLE SPEED)	L	L	H/L
FUNCTION	REC MODE	COPY (PIN 9)	DOLBY P/R (PIN 10)																							
TAPE	NOT RECORDING	L	L																							
	RECORDING	H	L																							
OTHERS	NOT RECORDING	L	L																							
	RECORDING	L	H																							
	DUBBING copy (AT STANDARD AND DOUBLE SPEED)	L	L																							
11	PB1/2	UN	This pin controls switching of the playback mechanism (L: 1 mechanism).	H/L																						
12	2 REC MUTE	UN	This pin is at "L" only in the 2 mechanism record mode.	H																						
13	MS. PULSE	N	This pin detects the MS pulse (H: during playback).	H/L																						
14	1 REC MUTE	UN	This pin is at "L" only in the 1 mechanism record mode.	H																						
15	FADER	UN	This pin turns the Q601 ON to discharge the capacitor C642, which controls the time constant of the build up time of the power supply to the BIAS oscillation circuit. Turning the FADER ON selects the REC PAUSE mode and this pin goes to "H". After that, depressing the PLAY button (either the FWD or the REV) returns this pin from "H" to "L". In the case of the FADER RECORD mode with the ASES activated, this pin remains at "H" for 100msec after starting.	H																						
16	PB. MUTE	UN	This pin is at "L" only during DECK replay.	H																						
17	1 PULSE	N	This pin detects the 1 mechanism hall device pulse.	H/L																						
18	2 PULSE	N	This pin detects the 2 mechanism hall device pulse.	H/L																						
19	HI/NORM	N	This pin controls the tape speed (H: double speed).	H/L																						
20	POW.RY	O	This pin becomes "H" when power is turned on.	H																						
21	1. MOTOR	N	This pin controls the 1 mechanism motor (L: motor running).	L																						

NO	Terminal Name	I/O	Function	Active								
22	P. ASES	N	This pin controls the PARALLEL ASES LED.	L								
23	1. ●	N	This pin controls the 1 mechanism REC LED.	L								
24	2. MOTOR	N	This pin controls the 2 mechanism motor (L: motor running).	L								
25	DISCO ASES	O	Not used.	H								
26	SP. RY	O	This pin controls the SP RELAY (RY351). This mutes for 5 seconds after the power is turned on, and turns the SP RELAY OFF immediately after the power is turned off.	L								
27	V-UP	O	This pin turns the Motor Volume up or down by controlling the TA7291.	H								
28	V-DOWN	O		H								
				<table border="1"> <thead> <tr> <th></th> <th>V-UP (PIN 27)</th> <th>V-DOWN (PIN 28)</th> </tr> </thead> <tbody> <tr> <td>UP</td> <td>H</td> <td>L</td> </tr> <tr> <td>DOWN</td> <td>L</td> <td>H</td> </tr> </tbody> </table>		V-UP (PIN 27)	V-DOWN (PIN 28)	UP	H	L	DOWN	L
	V-UP (PIN 27)	V-DOWN (PIN 28)										
UP	H	L										
DOWN	L	H										
29	L-MUTE	O	This pin activates muting for 0.5 seconds when the FUNCTION is switched or SURROUND or DIRECT is turned to ON/OFF. This mutes the output volume (VR391) for 0.3 seconds after the SP RELAY is turned ON with the power ON.	H								
30	TEST	—	Not used (GND)	—								
31	V _{SS}	—	GND	—								
32	OSC1	—	Connects 4.19 MHz ceramic resonator.	—								
33	OSC2	—		—								
34	RES	—	RESET pin	L								
35	A	O	These pins transfer 3bit data to the KEYSKAN OUT IC802 (M74LS42P) which are used as the KEYSKAN output KO0–KO6.	L/H								
36	B	O		L/H								
37	C	O		L/H								
38	1.▶ (LED)	N	This pin controls the 1 mechanism FWD PLAY LED.	L								
39	1.◀ (LED)	N	This pin controls the 1 mechanism REV PLAY LED.	L								
40	2.▶ (LED)	N	This pin controls the 2 mechanism FWD PLAY LED.	L								
41	2.◀ (LED)	N	This pin controls the 2 mechanism REV PLAY LED.	L								
42	2. ● (LED)	N	This pin controls the 2 mechanism REC LED.	L								
43	ASES (LED)	N	This pin controls the ASES (FADE LED).	L								
44	R. REC (LED)	N	This pin controls the RELAY REC LED.	L								
45	R. ASES (LED)	N	This pin controls the RELAY ASES LED.	L								
46	SOL2B	O	This pin controls the 2 mechanism FF/REW solenoid.	H								
47	SOL2A	O	This pin controls the 2 mechanism PLAY solenoid.	H								
48	SOL1B	O	This pin controls the 1 mechanism FF/REW solenoid.	H								
49	SOL1A	O	This pin controls the 1 mechanism PLAY solenoid.	H								

NO	Terminal Name	I/O	Function	Active
50 }	K10 }	I	This pin for the KEY matrix input.	H/L
55	K15			
56	K16	N		
57	K17			
58	SURROUND	UN	This pin controls the SURROUND ON/ $\overline{\text{OFF}}$.	H
59	DIRECT	UN	This pin controls the DIRECT ON/ $\overline{\text{OFF}}$.	H
60	F-MUTE	UN	This pin controls muting of the DATA OUT and VIDEO OUT pins. The muting duration is 0.5 seconds when FUNCTION is switched, or 0.3 seconds after the power is turned on, followed by energizing the SP RELAY (RY351).	H
61	INH	UN	These pins switch the FUNCTION.	H/L
62	B	UN		H/L
63	A	UN		H/L
64	VDD	—	+5V	—





8. FOR HE TYPE

CONTRAST OF MISCELLANEOUS PARTS

NOTES:

- Parts without part number cannot be supplied.
- The  mark found on some component parts indicates the importance of the safety factor of the part. Therefore, when replacing, be sure to use parts of identical designation.
- Parts marked by "⊙" are not always kept in stock. Their delivery time may be longer than usual or they may be unavailable.

The DC-Z93/HE type is the same as the DC-Z93/HB type with the exception of the following sections.

Mark	Symbol & Description	Part No.		Remarks
		HB type	HE type	
	POWER SUPPLY assembly	AWZ2241	AWZ2239	
	CONNECT assembly	Non supply	Non supply	
	FU2001 Fuse (T2A/250V)	AEK-511	AEK-017	
	FU2003 Fuse (T1.6A/250V)	AEK-510	AEK-405	
	FU2004,FU2005 Fuse (T1.25A/250V)	AEK-509	AEK-018	
	AC Power cord	ADG1052	ADG1049	
	Operating Instructions (English)	ARB1218	
	Operating Instructions	ARC1182	
	Operating instructions	ARE1146	

POWER SUPPLY assembly (AWZ2239)

The POWER SUPPLY assembly (AWZ2239) is the same as the POWER SUPPLY assembly (AWZ2241) with the exception of the following sections.

Mark	Symbol & Description	Part No.		Remarks
		AWZ2241	AWZ2239	
	AC socket (OUTLET)	AKP1035	AKP1034	

CONNECT assembly

The difference in parts between the CONNECT assemblies HB type and HE type is only the jumper wire.

9. PANEL FACILITIES

DC-Z93

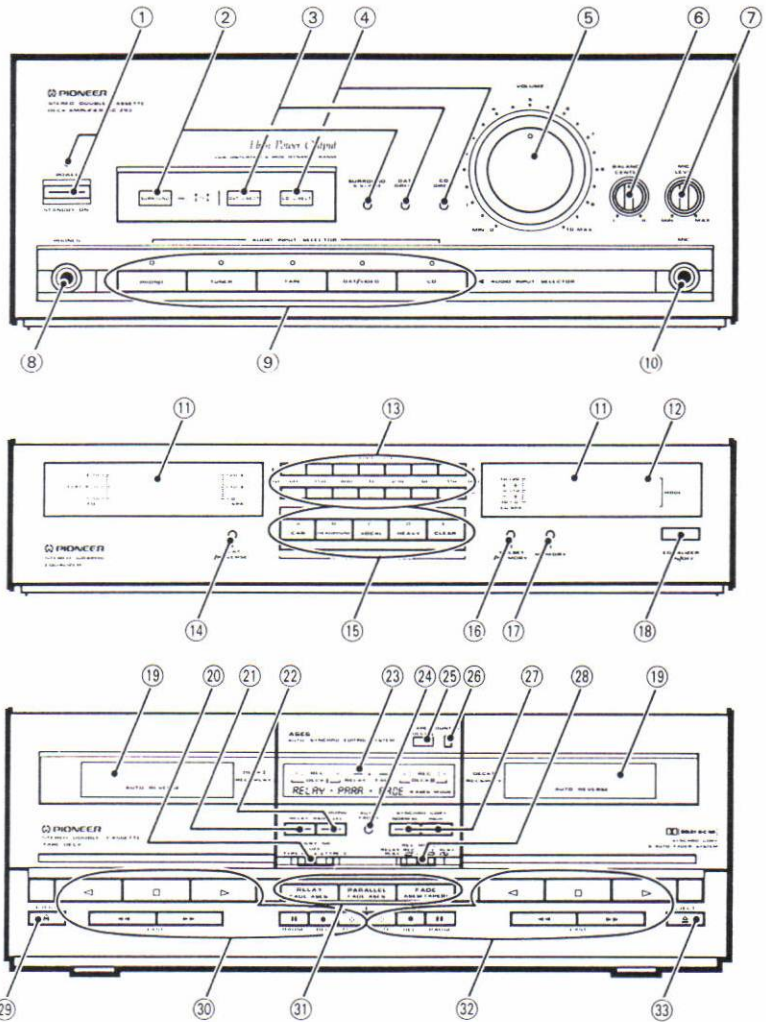
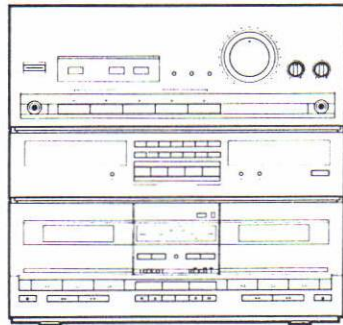

DC-Z93

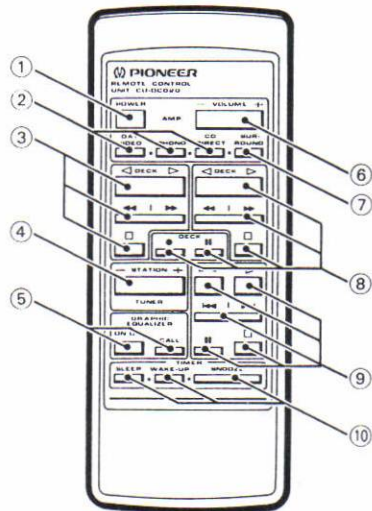
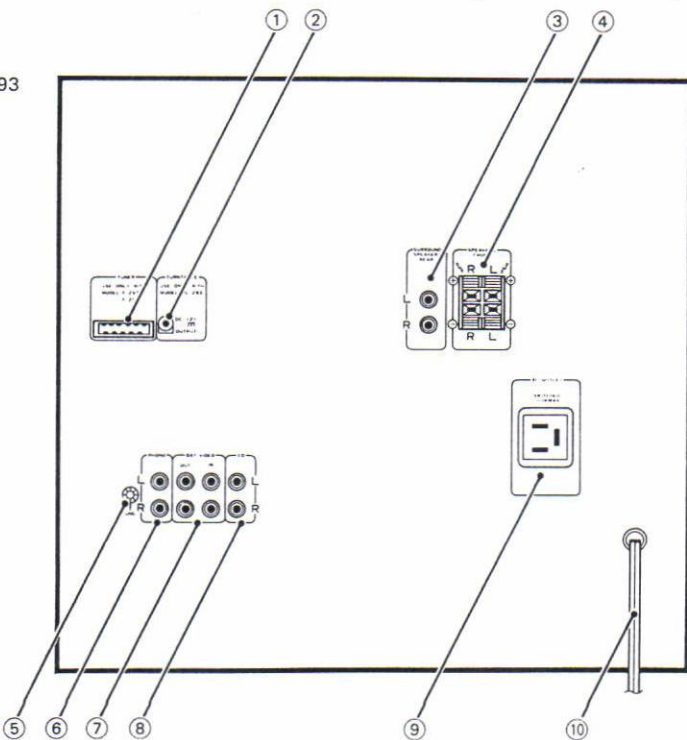

REAR PANEL FACILITIES

Cassette tape deck amplifier: DC-Z93

① TUNER jacks

Connect the tuner cord here.

② TURNTABLE (DC 12 V OUTPUT) jack

This jack supplies power to the turntable.

③ SURROUND SPEAKERS jacks

Connect the Surround speaker systems.

NOTE:

Connect a speaker system having a nominal impedance of 16 Ω or more.

④ SPEAKERS terminals

L: Connect the left speaker system as seen from the listening position.

R: Connect the right speaker system as seen from the listening position.

NOTE:

Connect a speaker system having a nominal impedance ranging from 6 Ω to 16 Ω .

⑤ Ground terminal (GND)

Connect this to the ground terminal on the turntable (except for PL-Z93).

⑥ PHONO input jacks

Connect the output cord of the turntable to these jacks.

⑦ DAT/VIDEO jacks

IN: Connect to audio output jacks of DAT, LD player or VCR, etc.

OUT: Connect to audio input jacks of DAT or VCR, etc.

⑧ CD input jacks

Connect to output jacks of a CD player.

⑨ AC OUTLET (SWITCHED 100 W MAX)

Power supplied through this outlet is turned on and off by the cassette tape deck amplifier's POWER switch. Total electrical power consumption of connected equipment should not exceed 100 W.

NOTE:

Do not connect appliances with high power consumption such as heaters, irons, or television sets to the AC OUTLET in order to avoid overheating or fire risk.

This can cause the cassette tape deck amplifier to malfunction.

⑩ Power cord

Connect this to the AC wall socket.

FRONT PANEL FACILITIES

Cassette tape deck amplifier: DC-Z93

- This unit has an automatic tape type selector.
- Recording and playback are possible on both deck I and II.
- Sound can be recorded as adjusted by the graphic equalizer.

Amplifier section

① POWER STANDBY/ON switch

This is the switch for electric power.

ON: When set to the ON position, power is supplied and the unit becomes operational.

The POWER indicator lights.

STANDBY: When set to the STANDBY position, the main power flow is cut and the unit is no longer fully operational. A minute flow of power feeds the unit to maintain operation readiness.

When the POWER indicator is off, the unit is in STANDBY. (The tuner display shows only the time.)

② SURROUND & STEREO WIDE switch/indicator

By turning this switch ON, you can enjoy surround reproduction when rear speakers are used.

By turning this switch ON, you can enjoy STEREO WIDE reproduction with greater left-right spread when rear speakers are not used.

The indicator lights when the switch is on.

NOTE:

- In the case of monaural source, SURROUND & STEREO WIDE effects cannot be obtained.
- SURROUND & STEREO WIDE functions do not operate if CD DIRECT or DAT DIRECT is on.

③ DAT DIRECT switch/indicator

Press this switch to listen to a DAT without passing the signal through sound quality adjustment circuits.

④ CD DIRECT switch/indicator

Press this switch to listen to a CD without passing the signal through sound quality adjustment circuits.

⑤ VOLUME control

⑥ BALANCE control

Used for changing the balance between left and right channels. Usually set this control to the centre position.

⑦ MIC LEVEL control

Used for adjusting the volume of microphone.

⑧ PHONES (Headphones) jack

For stereo headphones.

NOTE:

There is no output from the speakers when headphones are plugged into PHONES jack.

⑨ Input selector switches/indicators

[PHONO]

Press to play records on a turntable connected to the PHONO jacks.

[TUNER]

Press to listen to radio broadcast.

[TAPE]

Press to listen to cassette tape or VCR etc.

[DAT/VIDEO]

Press to listen to digital audio tape.

[CD]

Press to listen to a CD player connected to the CD jacks.

⑩ MIC (Microphone) jack

This is a standard jack for connecting a microphone.

Graphic Equalizer section

11 Graphic equalizer/Spectrum analyzer display

Usually this is the spectrum analyzer display. And becomes a graphic equalizer display during operation of the EQUALIZING CONTROL switches.

12 MODE display

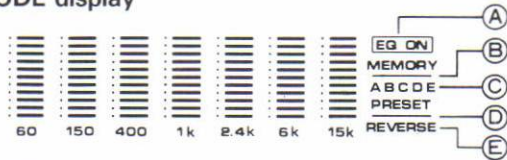

A EQ ON indicator

Lights when the EQUALIZER switch is set to ON. When this indicator is lit, the graphic equalizer can be used to adjust sound quality.

B MEMORY indicator

When the line under "MEMORY" is lit, it indicates that the equalization curves you input in the memory recall switches can be recalled.

C A – E indicators

Indicates which equalization curve is currently recalled.

A: Curve stored in A/CAR. (Preset CAR or Memory A)

B: Curve stored in B/PHONES. (Preset PHONES or Memory B)

C: Curve stored in C/VOCAL. (Preset VOCAL or Memory C)

D: Curve stored in D/HEAVY. (Preset HEAVY or Memory D)

E: Curve stored in E/CLEAR. (Preset CLEAR or Memory E)

D PRESET indicator

When the line under "PRESET" is lit, it indicates that the equalization curves factory preset in the memory recall switches can be recalled.

E REVERSE indicator

Lights when FLAT/REVERSE switch is used to invert the equalization curve.

13 EQUALIZING CONTROL switches

These strengthen or weaken the indicated frequency band. Press the upper switch to emphasize; press the lower switch to attenuate.

14 FLAT/REVERSE switch

Press once to reset the equalizer to flat response (no equalization). Press again to reverse a previous curve (boosted frequencies will be attenuated, and vice versa).

15 Memory recall switches

Used for recalling equalization curves.

16 PRESET/MEMORY switch

Determines whether the equalizer curves recalled by the Memory recall switches are your memorized curves or factory preset curves.

17 MEMORY switch

Used for storing equalization curves you input in the memory recall switches.

18 EQUALIZER ON/OFF switch

Turns the equalizer on and off. The EQ ON indicator lights when this switch is on.

The equalizer can not be used to adjust the sound when CD DIRECT or DAT DIRECT is on.

Cassette Tape Deck Section

19 Cassette door

20 DOLBY* NR switch

Set this switch to B or C for recording with the built-in Dolby NR systems and for playback of tapes which have been recorded using the Dolby NR systems.

- It is recommended that tapes recorded with Dolby NR (Type B or Type C) be so marked on the label. This will help prevent incorrect setting of the noise reduction switch during playback.

*

Dolby noise reduction manufactured under license from Dolby Laboratories Licensing Corporation.

"DOLBY" and the double-D symbol  are trademarks of Dolby Laboratories Licensing Corporation.

21 RELAY RECORDING switch

Use for relay recording from Deck I to Deck II.

Deck II starts recording when Deck I finishes.

To use put both decks in stop mode.

22 PARALLEL RECORDING switch

Deck I and Deck II record at the same time.

To use put both decks in stop mode.

23 Operation indicators

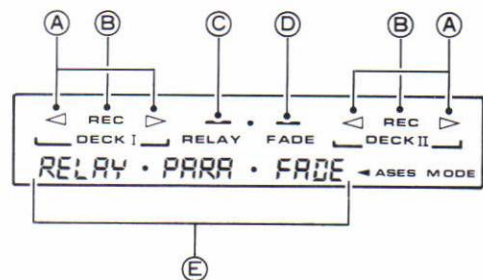

A Direction (<, >): Indicates direction of tape travel during recording or playback. Flashes slowly in pause mode. Flashes rapidly during Music Search (MS).

B REC: Lights when recording.

C RELAY: Indicates relay recording in progress using Deck I and Deck II.

D FADE: Lights when AUTO FADER switch is on.

E ASSES MODE

RELAY: relay edit in progress.

PARA: parallel edit in progress.

FADE: fade edit in progress.

24 AUTO FADER switch

Used for gradually fading out a recorded tape in Deck II. (The sound will be completely cut off after approximately 10 seconds and the tape will stop.)

25 DECK II COUNTER

26 Counter reset switch

Press this switch to reset the Deck II tape counter display to 000.

27 SYNCHRO COPY switches

Used for tape copying.

NORMAL: Copying from the Deck I tape to the Deck II tape at normal recording/playback speed.

HIGH: Copying at about twice normal tape speed. (Copies can be made in about half the NORMAL time.)

28 REVERSE MODE switch

Switch position	During playback	During recording
RELAY REC PLAY ⇌	Plays both tape sides. When one deck finishes playback, the other deck begins playback of both tape sides for 6 times. If there is a tape in only one deck, then that deck continuously plays both sides of the tape for 6 times.	Records on one side.
REC PLAY ⇌ ↻	Plays both tape sides for 6 times maximum.	Records on both sides.

29 Deck I EJECT switch

30 Deck I Operation switches

- ▷ (PLAY: FWD) .. For playing back a tape in the forward mode.
- ◁ (PLAY: REV) ... For playing back a tape in the reverse mode.
- (STOP) For stopping the tape.
- ▶▶ FAST Fast forward in forward mode, rewind in reverse mode. Music search (MS) starts if this is pressed during playback.
- ◀◀ FAST Rewind in forward mode, fast forward in reverse mode. Music search (MS) starts if this is pressed during playback.
- II PAUSE Temporarily stops tape travel. Cancels pause mode when pressed again or press the PLAY switch.
- REC To set to recording standby mode. The REC indicator lights and the direction indicators (◁ and ▷) flash. Recording begins when you press the PLAY switch (◁ or ▷).
- MUTE Used for creating a blank space between songs. The unrecorded space is created for as long as this switch is kept depressed.

31 A.S.E.S. switches

Used for automatically recording a CD on cassette tape.

RELAY: Recording continues on Deck II after tape ends on Deck I. If using this unit together with the PD-Z73T CD player, Deck II will record disc II after Deck I finishes recording disc I.

PARALLEL: Deck I and Deck II record at the same time.

FADE: The sound fades out at the end of the tape.

32 Deck II Operation switches: Same as Deck I operation switches 30

33 Deck II EJECT switch

Remote control unit

1 POWER key

2 Function keys

- DAT/VIDEO Sets function to DAT/VIDEO.
- PHONO Sets function to PHONO.
- CD DIRECT Sets function to CD DIRECT.

3 DECK I operation keys: Same as Deck I operation switches 30 (Except PAUSE, REC, MUTE).

4 TUNER STATION key

- Before operation, memorize broadcast stations in the STATION CALL switches.
- + Stations change in order in the upward direction
- Stations change in order in the downward direction.

5 GRAPHIC EQUALIZER operation keys

- ON/OFF: Turns the equalizer on and off.
- CALL: Recalls the preset equalization curves (PRESET) and memorized equalization curves (MEMORY) in sequence.

6 VOLUME + (UP)/- (DOWN) key

When pressed, VOLUME on the amplifier is actually moved by a motor.

7 SURROUND key

Turns SURROUND & STEREO WIDE on and off.

8 Deck II operation keys: Same as Deck I operation switches 30 (Except MUTE).

9 CD operation keys

- Perform the connections so that the CD player is operated by the remote control unit.
- ▷ Play
- DISC DISC selection
- Stop
- ⏸ Pause
- ◀▶ Track search

NOTE:
Note that the DISC selector key on the remote control unit may not operate, depending on the CD player used.

⑩ Timer operation keys

SLEEP: Sets the sleep timer. Each time you press this key, the setting changes as shown here. The current setting is shown on the tuner display. Power turns off when your set time has elapsed.

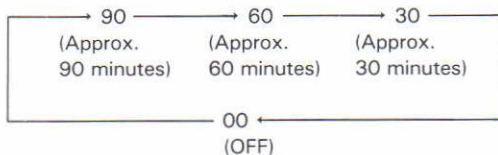

If you press the SLEEP key during SLEEP operation, the display will show the time remaining till power turns off.

WAKE-UP: Timer playback setting/cancellation can be performed when the timer playback time has been set. This is shown in the tuner display section.

SNOOZE: Turns off power if pressed after timer playback begins. Timer playback begins again approx. 5 minutes later.

The amplifier input selector automatically switches to the music source being operated when you press the CD playback (▷), cassette tape deck playback (◁, ▷), or tuner station controls.

NOTE:

It is not possible to operate the CD player with the remote control unless the remote control cord is connected.

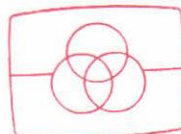

Free service manuals
Gratis schema's

Digitized by

www.freesevicemanuals.info

Range of remote control

When the remote control unit is pointed at the remote sensor window on the tuner and any of its keys is pressed, the tuner and other components can be operated by remote control.

Distance: Within a range of approx. 7 meters from the remote sensor window on the tuner.

Angle: Within approx. 30 degrees from the center of the remote sensor window on the tuner.

Remote control will not be possible if there is an obstacle between the remote control unit itself and the remote sensor window on the tuner.

Performance of the remote control unit is adversely affected in the presence of strong fluorescent light. Keep such lights away, specially from the sensor window.

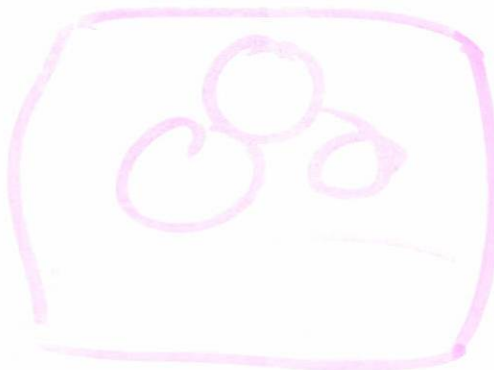

10. CONNECTIONS

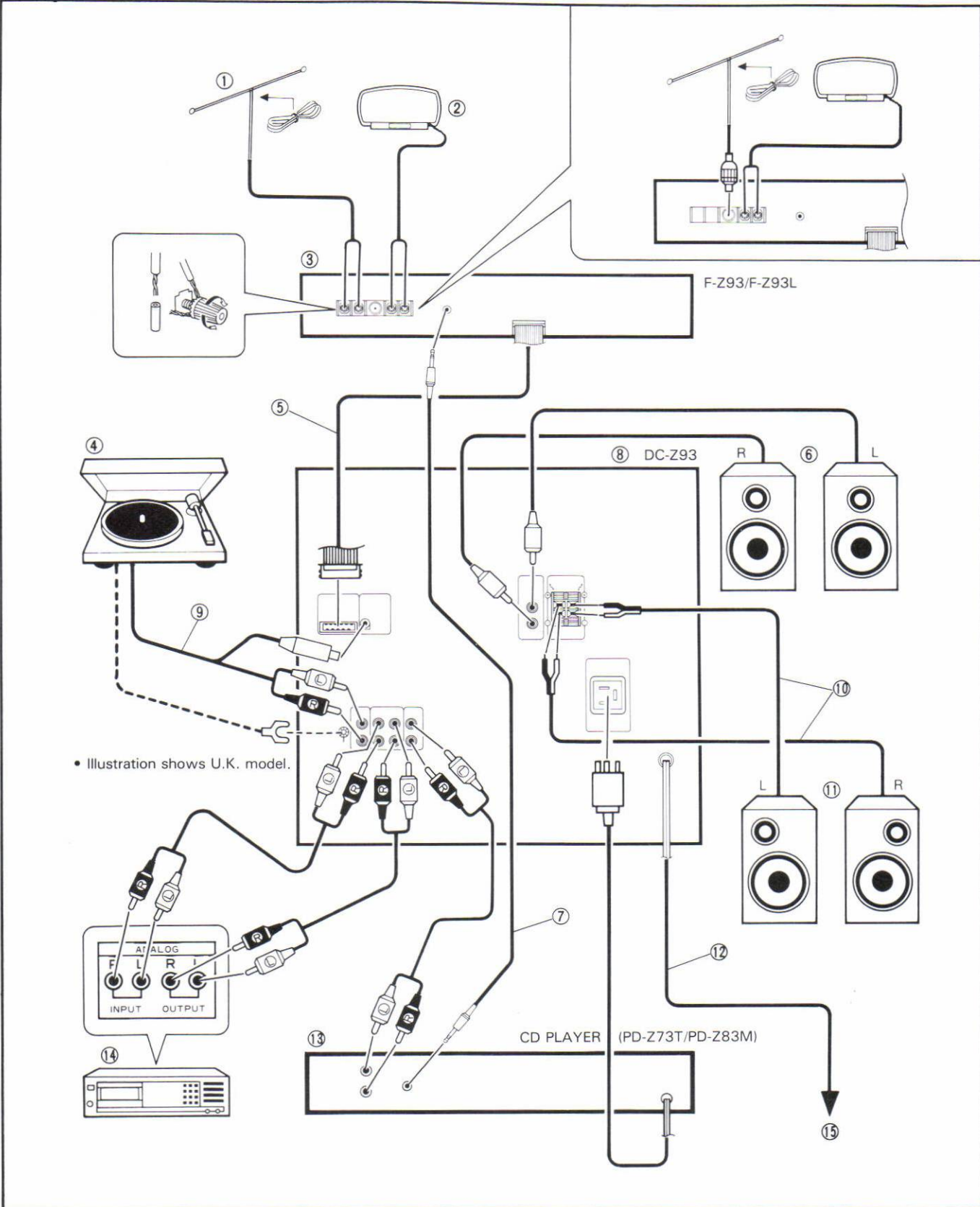

- ① Accessory FM antenna
- ② Accessory AM loop antenna
- ③ FM/AM tuner (F-Z93 or F-Z93L)
- ④ Turntable (PL-Z93)
- ⑤ Tuner input/output cord
- ⑥ Surround speaker system
- ⑦ CD player control cord
- ⑧ Cassette tape deck amplifier
- ⑨ Turntable output cord
- ⑩ Speakers cord
- ⑪ Speaker system
- ⑫ Power cord
- ⑬ CD player (Separately sold PD-Z73T or PD-Z83M)
- ⑭ Digital audio tape deck (DAT) or video cassette recorder (VCR)
- ⑮ To the AC wall socket

Plug the power cord into the AC wall socket only after all the connections have been completed.

If the FM antenna terminal of the FM/AM tuner is a PAL connector then refer to connection diagram

Proceed as follows with the set up and connections.

1. Place the cassette tape deck amplifier on top of the CD player.
2. Connect the CD player OUTPUT jacks to the cassette tape deck amplifier CD INPUT jacks with audio cords.
If using this unit together with the optional CD player PD-Z73T or PD-Z83M, connect the control cord ⑦.
3. Place the tuner on top of the cassette tape deck amplifier.
4. Connect the tuner input/output cord ⑤ to cassette tape deck amplifier.

TUNER CONNECTION

Insert the connector until it locks, thus ensuring that it is connected. When disconnecting the connector, pull it in the opposite direction while pressing the left and right claws.

5. Connect the FM antenna ① and the AM loop antenna ② to the tuner's antenna terminals.
6. Place the turntable on top of the tuner.
7. Connect the turntable's cords ⑨ to the cassette tape deck amplifier's jacks.
If using the turntable PL-Z93, connect the turntable's audio cords and power supply cord respectively to the cassette tape deck amplifier's PHONO jacks and DC 12V OUTPUT jack.
If using a different turntable, connect its audio cord and ground cord.
8. Use the "DAT/VIDEO" jacks for connection to the audio input/output jacks of a DAT or VCR.
If connecting an LD player, connect the LD player's audio output jacks to the "DAT/VIDEO" input jacks.

NOTE:

- Insert the plugs securely into the jacks. Improper connection can lead to sound distortion or malfunction.
- The white plug is for the left channel connection and the red plug for the right channel connection.

9. Connect the speaker cords ⑩ to SPEAKERS terminals.
Connect the "+" terminals on the cassette tape deck amplifier to the "+" terminals on the speakers, the "-" terminals on the cassette tape deck amplifier to the "-" terminals on the speakers.

Connecting the speaker cords.

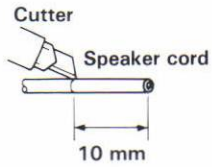
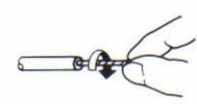
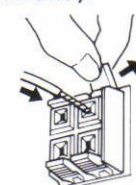
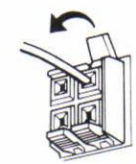
1.  Cutter
Speaker cord
10 mm
2.  Twist the strands.
3.  Push away.
4.  Pull back.

NOTE:

Do not allow the conductors of the cords to project out of the terminals or to come into contact with other conductors. A breakdown or failure may occur when conductors touch.

Speaker impedance

Connect speaker systems with a nominal impedance of ranging from 6 to 16 Ω .

Surround speaker connection

Connect the plugs properly.

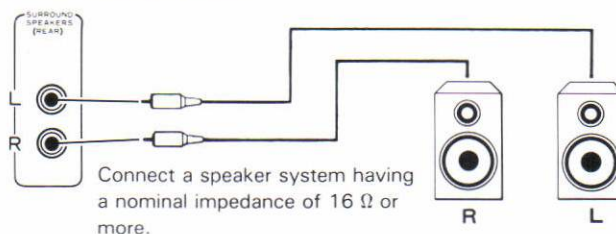

10. Finally, connect the power cord ⑫ to the AC wall socket ⑮.

CONDENSATION

When the unit is brought into a warm room from previously cold conditions or when the room temperature is suddenly increased, condensation may form inside and the unit may not be able to attain its full performance. In cases like this, allow the unit to stand for about an hour or raise the room temperature gradually.

