

Pioneer

Service Manual

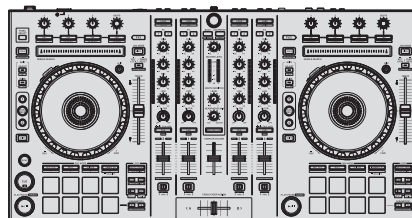

DDJ-SX

ORDER NO.
RRV4382

DJ Controller

DDJ-SX

THIS MANUAL IS APPLICABLE TO THE FOLLOWING MODEL(S) AND TYPE(S).

Model	Type	Power Requirement	Remarks
DDJ-SX	UXECB	AC 100 V to 240 V	
DDJ-SX	SVYXE8	AC 100 V to 240 V	
DDJ-SX	FLPXE	AC 100 V to 240 V	
DDJ-SX	AXE5	AC 100 V to 240 V	
DDJ-SX	KXE5	AC 100 V to 240 V	



PIONEER CORPORATION 1-1, Shin-ogura, Saiwai-ku, Kawasaki-shi, Kanagawa 212-0031, Japan

PIONEER ELECTRONICS (USA) INC. P.O. Box 1760, Long Beach, CA 90801-1760, U.S.A.

PIONEER EUROPE NV Haven 1087, Keetberglaan 1, 9120 Melsele, Belgium

PIONEER ELECTRONICS ASIACENTRE PTE. LTD. 253 Alexandra Road, #04-01, Singapore 159936

©PIONEER CORPORATION 2012

SAFETY INFORMATION



This service manual is intended for qualified service technicians; it is not meant for the casual do-it-yourselfer. Qualified technicians have the necessary test equipment and tools, and have been trained to properly and safely repair complex products such as those covered by this manual.

Improperly performed repairs can adversely affect the safety and reliability of the product and may void the warranty. If you are not qualified to perform the repair of this product properly and safely, you should not risk trying to do so and refer the repair to a qualified service technician.

WARNING

This product may contain a chemical known to the State of California to cause cancer, or birth defects or other reproductive harm.

Health & Safety Code Section 25249.6 - Proposition 65

(FOR USA MODEL ONLY)

1. SAFETY PRECAUTIONS

The following check should be performed for the continued protection of the customer and service technician.

LEAKAGE CURRENT CHECK

Measure leakage current to a known earth ground (water pipe, conduit, etc.) by connecting a leakage current tester such as Simpson Model 229-2 or equivalent between the earth ground and all exposed metal parts of the appliance (input/output terminals, screwheads, metal overlays, control shaft, etc.). Plug the AC line cord of the appliance directly into a 120 V AC 60 Hz outlet and turn the AC power switch on. Any current measured must not exceed 0.5 mA.

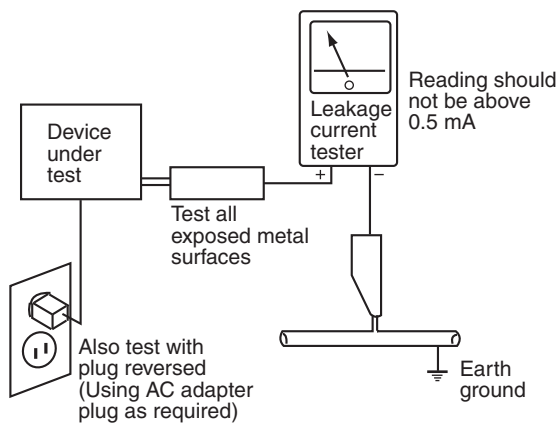

AC Leakage Test

ANY MEASUREMENTS NOT WITHIN THE LIMITS OUTLINED ABOVE ARE INDICATIVE OF A POTENTIAL SHOCK HAZARD AND MUST BE CORRECTED BEFORE RETURNING THE APPLIANCE TO THE CUSTOMER.

2. PRODUCT SAFETY NOTICE

Many electrical and mechanical parts in the appliance have special safety related characteristics. These are often not evident from visual inspection nor the protection afforded by them necessarily can be obtained by using replacement components rated for voltage, wattage, etc. Replacement parts which have these special safety characteristics are identified in this Service Manual.

Electrical components having such features are identified by marking with a ⚠ on the schematics and on the parts list in this Service Manual.

The use of a substitute replacement component which does not have the same safety characteristics as the PIONEER recommended replacement one, shown in the parts list in this Service Manual, may create shock, fire, or other hazards.

Product Safety is continuously under review and new instructions are issued from time to time. For the latest information, always consult the current PIONEER Service Manual. A subscription to, or additional copies of, PIONEER Service Manual may be obtained at a nominal charge from PIONEER.

CONTENTS

SAFETY INFORMATION.....	2
1. SERVICE PRECAUTIONS.....	3
1.1 NOTES ON SOLDERING.....	3
1.2 SERVICE NOTICE.....	4
2. SPECIFICATIONS.....	5
3. BASIC ITEMS FOR SERVICE.....	6
3.1 CHECK POINTS AFTER SERVICING.....	6
3.2 JIGS LIST.....	6
3.3 PCB LOCATIONS.....	7
4. BLOCK DIAGRAM.....	8
4.1 OVERALL WIRING DIAGRAM.....	8
4.2 OVERALL BLOCK DIAGRAM.....	10
5. DIAGNOSIS.....	12
5.1 TROUBLESHOOTING.....	12
6. SERVICE MODE.....	16
6.1 SERVICE MODE.....	16
7. DISASSEMBLY.....	23
8. EACH SETTING AND ADJUSTMENT.....	31
8.1 NECESSARY ITEMS TO BE NOTED.....	31
8.2 UPDATING OF THE FIRMWARE.....	31
8.3 ITEMS FOR WHICH USER SETTINGS ARE AVAILABLE.....	33
9. EXPLODED VIEWS AND PARTS LIST.....	34
9.1 PACKING SECTION.....	34
9.2 EXTERIOR SECTION.....	36
10. SCHEMATIC DIAGRAM.....	40
10.1 CONTROLPCB ASSY A, B, and TRANSFER PCB ASSY.....	40
10.2 DSP, OUTPUT and BAL. PCB ASSYS.....	42
10.3 MIX and CH FADER PCB ASSYS.....	44
10.4 FRONT PCB ASSY.....	46
10.5 TOUCH PCB ASSY.....	47
10.6 LED PCB ASSY.....	48
10.7 WAVEFORMS.....	49
11. PCB CONNECTION DIAGRAM.....	52
11.1 CONTROLPCB ASSY A, B, and TRANSFER PCB ASSY.....	52
11.2 DSP, OUTPUT and BAL. PCB ASSYS.....	56
11.3 MIX and CH FADER PCB ASSYS.....	60
11.4 FRONT and TOUCH PCB ASSYS.....	64
11.5 LED PCB ASSY.....	66
12. PCB PARTS LIST.....	67

1. SERVICE PRECAUTIONS

1.1 NOTES ON SOLDERING

- For environmental protection, lead-free solder is used on the printed circuit boards mounted in this unit.
Be sure to use lead-free solder and a soldering iron that can meet specifications for use with lead-free solders for repairs accompanied by reworking of soldering.
- Compared with conventional eutectic solders, lead-free solders have higher melting points, by approximately 40 °C.
Therefore, for lead-free soldering, the tip temperature of a soldering iron must be set to around 373 °C in general, although the temperature depends on the heat capacity of the PC board on which reworking is required and the weight of the tip of the soldering iron.

Do NOT use a soldering iron whose tip temperature cannot be controlled.

Compared with eutectic solders, lead-free solders have higher bond strengths but slower wetting times and higher melting temperatures (hard to melt/easy to harden).

The following lead-free solders are available as service parts:

- Parts numbers of lead-free solder:
GYP1006 1.0 in dia.
GYP1007 0.6 in dia.
GYP1008 0.3 in dia.

1.2 SERVICE NOTICE

A ■ About Demo Mode

This unit will automatically enter Demo mode if it is left unoperated for 10 minutes in Normal Operation mode, and a demonstration with LED illumination will start.

To cancel this mode, operate any control or button of this unit.

To disable Demo mode, change the setting in the Utility settings. (For details, refer to the operating instructions.)

■ Notes on Parts Replacement

(1) Detachment/Reattachment of the front panel

For replacement of the CONTROL PCB Assy A/B or MIX PCB Assy, the front panel must be detached.

B The front panel is secured to the Chassis Assy with double-back tape at 4 locations for prevention of lifting. Be fully careful not to deform the front panel when detaching it.

For details, see "■ About the double-back tape that is used for securing the front panel and the Chassis Assy" in "[3] Each PCB assembly," "7.DISASSEMBLY."

(2) When replacing the LED & COVER Assy or WHEEL Assy of the JOG dial section

■ When replacement of the LED & COVER Assy is required, the Windows Lens must be detached, because the Windows Lens is attached to the WHEEL Assy with double-back tape, which is attached around the outer periphery of the Windows Lens as a tube, and the LED & COVER Assy is placed in between them.

Once the Windows Lens is detached, the double-back tape cannot be reused. The Windows Lens may not be reused either, because it may be scratched, depending on the manner in which it was detached.

When replacement of the WHEEL Assy is required, the Windows Lens must also be detached and may not be reused.

C Note that when replacement of the following Assys are required, replace them together with the parts mentioned below.

Double-back tape is supplied with the WHEEL Assy.

- When the LED & COVER Assy is to be replaced: Double-back tape (TWIN ADHESIVE) (must), Windows Lens (if necessary)
- When the WHEEL Assy is to be replaced: Windows Lens (if necessary)

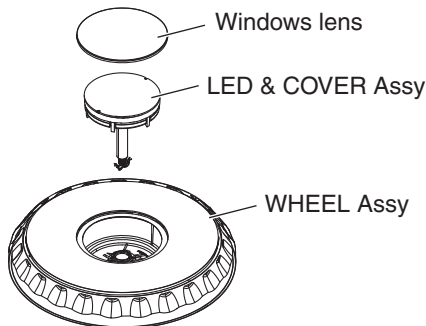

(3) When replacing the USB JACK

■ When the USB JACK in the DSP PCB Assy is to be replaced, the USB fixing bracket (USB fixed plate) must be detached together with it. To detach them, remove the solder from the JACK and USB fixed plate.

For improvement of durability, the JACK and USB fixed plate were glued with adhesive for the products of the initial production. (See the photo on the left below.)

In this case, replace the USB JACK together with the USB fixed plate.

The shape of the USB fixed plate has been modified so that it no longer requires adhesive for locking.

E (See the photo on the right below.)

The USB fixed plate for service is the one after this modification.

The numbers of the products that have the older version of the USB fixed plate (fixed with adhesive) is as shown below:

- DDJ-SX/UXECB: 2,000
- DDJ-SX/SVYXE8: 418
- DDJ-SX/FLPXE: 572

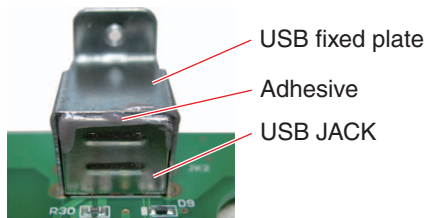

USB fixed plate for the initial products



USB fixed plate for service

2. SPECIFICATIONS

AC adapter

Power requirements..... AC 100 V to 240 V, 50 Hz/60 Hz
Rated current..... 800 mA
Rated output..... DC 5 V, 3 A

General – Main Unit

Main unit weight.....5.8 kg (13 lb)
Max. dimensions.....664 mm (W) × 70.4 mm (H) × 357 mm (D)
(26.1 in. (W) × 2.8 in. (H) × 14.1 in. (D))
Tolerable operating temperature..... +5 °C to +35 °C (+41 °F to +95 °F)
Tolerable operating humidity.....5 % to 85 % (no condensation)

Audio Section

Sampling rate44.1 kHz
A/D, D/A converter..... 24 bits
Frequency characteristic
USB, LINE, MIC..... 20 Hz to 20 kHz
S/N ratio (rated output, A-WEIGHTED)
USB 105 dB
LINE..... 95 dB
PHONO 92 dB
MIC..... 92 dB
Total harmonic distortion (20 Hz — 20 kHzBW)
USB0.003 %
LINE.....0.005 %
Standard input level / Input impedance
LINE.....-12 dBu/47 kΩ
PHONO-48 dBu/47 kΩ
MIC.....-52 dBu/10 kΩ
Standard output level / Load impedance / Output impedance
MASTER OUT 1+8 dBu/10 kΩ/330 Ω
MASTER OUT 2+2 dBu/10 kΩ/1 kΩ
BOOTH.....+8 dBu/10 kΩ/330 Ω
PHONE.....+4 dBu/32 Ω/32 Ω
Rated output level / Load impedance
MASTER OUT 126 dBu/10 kΩ
MASTER OUT 220 dBu/10 kΩ
BOOTH.....26 dBu/10 kΩ
Crosstalk
LINE..... 87 dB
Channel equalizer characteristic
HI.....-26 dB to +6 dB (13 kHz)
MID.....-26 dB to +6 dB (1 kHz)
LOW-26 dB to +6 dB (70 Hz)

Input / Output terminals

CD input terminal
RCA pin jack..... 2 sets
PHONO/LINE input terminals
RCA pin jack..... 2 sets
MIC1 terminal
XLR connector/phone jack (Ø 6.3 mm) 1 set
MIC2 terminal
Phone jack (Ø 6.3 mm)..... 1 set
MASTER OUT 1 output terminal
XLR connector..... 1 set
MASTER OUT 2 output terminal
RCA pin jacks 1 set
BOOTH output terminal
Phone jack (Ø 6.3 mm)..... 1 set
PHONES output terminal
Stereo phone jack (Ø 6.3 mm) 1 set
Stereo mini phone jack (Ø 3.5 mm) 1 set
USB terminal
B type 1 set

- For improvement purposes, specifications and design of this unit and the included software are subject to change without notice.

3. BASIC ITEMS FOR SERVICE

3.1 CHECK POINTS AFTER SERVICING

A Items to be checked after servicing

To keep the product quality after servicing, confirm recommended check points shown below.

No.	Procedures	Check points
1	Confirm that the customer complaint has been resolved. If the problem pointed out by the customer occurs with a specific source or operation, such as PC input, AUX/MIC input, Fader, or VOL, input that specific source then perform that specific operation for checking.	The symptoms in question must not be reproduced. There must be no abnormality in audio signals or operations.
2	Check operations of the operating elements. Enter Service mode.	There must be no errors in operations of each button, the jog dial, LEDs, NeedleSearch, VOL, fader control, and rotary encoder.
3	Check the analog audio output. Connect this unit with a PC with the DJ application (Serato DJ) installed, via USB, then play back audio.	There must be no errors, such as noise, in audio signals and operations of the MASTER/HEADPHONES outputs.
4	Check the analog audio input. Input an audio signal via AUX/MIC.	There must be no abnormality in audio signals or operations.
5	Check the appearance of the product.	No scratches or dirt on its appearance after receiving it for service.

See the table below for the items to be checked regarding audio.

Item to be checked regarding audio
Distortion
Noise
Volume too low
Volume too high
Volume fluctuating
Sound interrupted

3.2 JIGS LIST

Jigs List

Jig Name	Part No.	Purpose of use / Remarks
USB cable	GGP1193	for PC connection
AC adapter	411-S1-878-HA (UXECB), 411-S1-879-HA (SVYXE8), 411-S1-880-HA (FLPXE), 411-S1-881-HA (AXE5), 411-S1-882-HA (KXE5)	Accessory (Note: The power plug part is different.)

Lubricants and Glues List



Name	Part No.	Remarks
Adhesive	GYL1001	Refer to "7. DISASSEMBLY".
Adhesive	GYL1005	Refer to "7. DISASSEMBLY".
Grease	GEM1072	Refer to "7. DISASSEMBLY".

3.3 PCB LOCATIONS

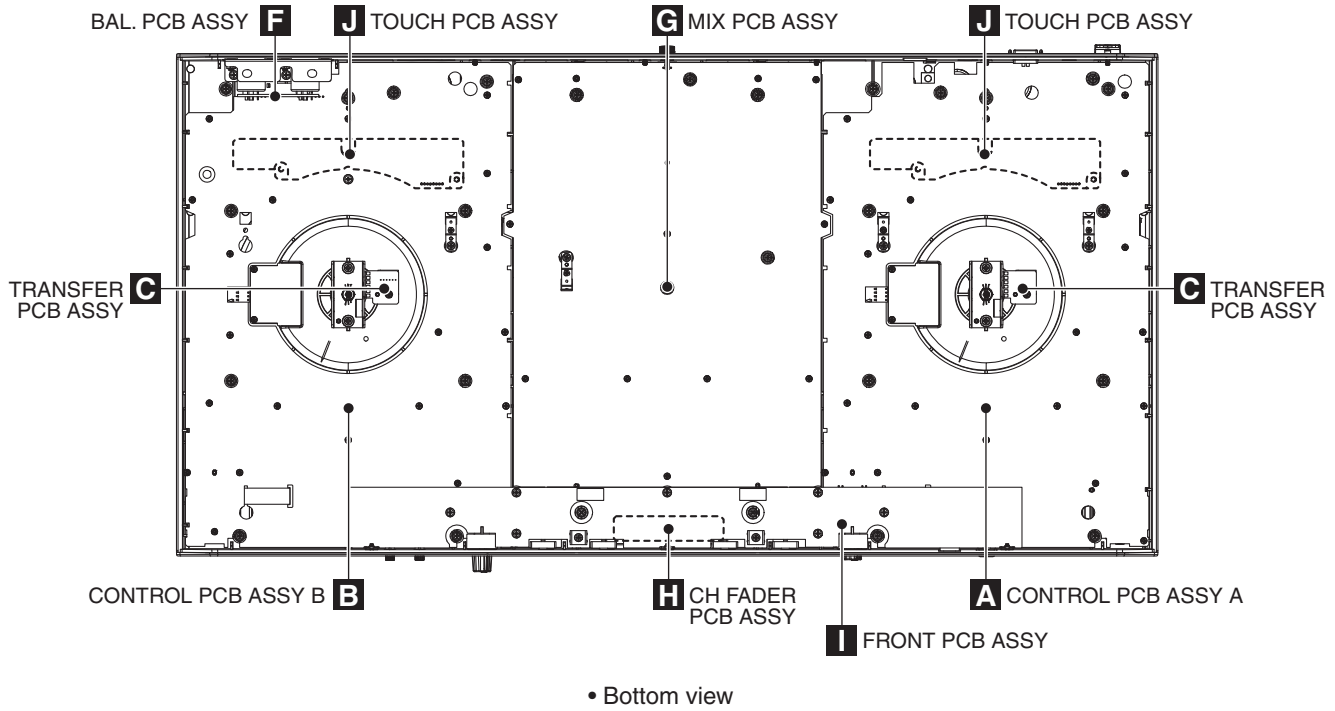
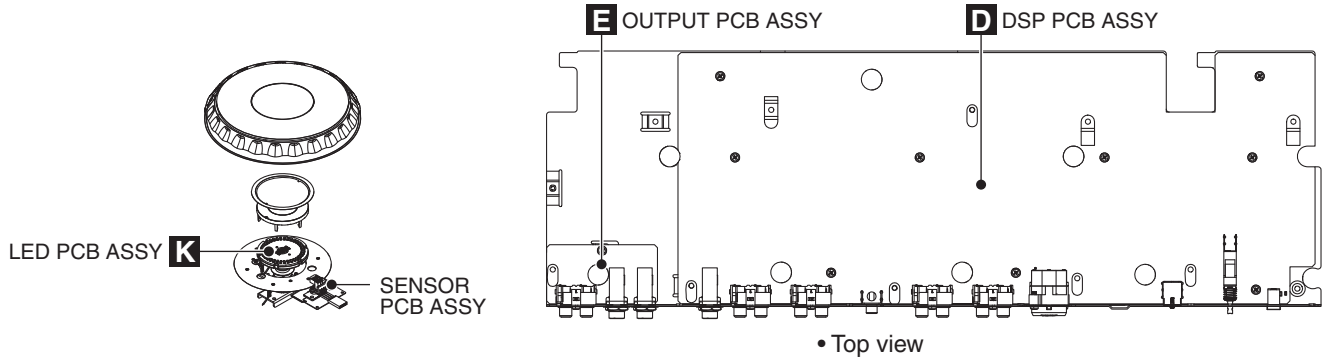

NOTES:

- Parts marked by “NSP” are generally unavailable because they are not in our Master Spare Parts List.
- The \triangle mark found on some component parts indicates the importance of the safety factor of the part. Therefore, when replacing, be sure to use parts of identical designation.

Mark No.	Description	Part No.	Mark No.	Description	Part No.
LIST OF ASSEMBLIES					
1..	CONTROL PCB ASSY A	704-DDJS1-A421-HA	1..	BAL. PCB ASSY	704-DDJS1-A423-HA
1..	CONTROL PCB ASSY B	704-DDJS1-A454-HA	1..	MIX PCB ASSY	704-DDJS1-A417-HA
1..	TRANSFER PCB ASSY	704-DDJS1-A429-HA	1..	CH FADER PCB ASSY	704-DJM250-A032-HA
1..	DSP PCB ASSY	704-DDJS1-A418-HA	1..	FRONT PCB ASSY	704-DDJS1-A424-HA
1..	OUTPUT PCB ASSY	704-DDJS1-A425-HA	1..	TOUCH PCB ASSY	704-DDJS1-A426-HA
			1..	LED PCB ASSY	704-DDJS1-A422-HA
			1..	SENSOR PCB ASSY	704-PDJ33-A007-HA

4. BLOCK DIAGRAM

4.1 OVERALL WIRING DIAGRAM

A

B

C

D

E

F

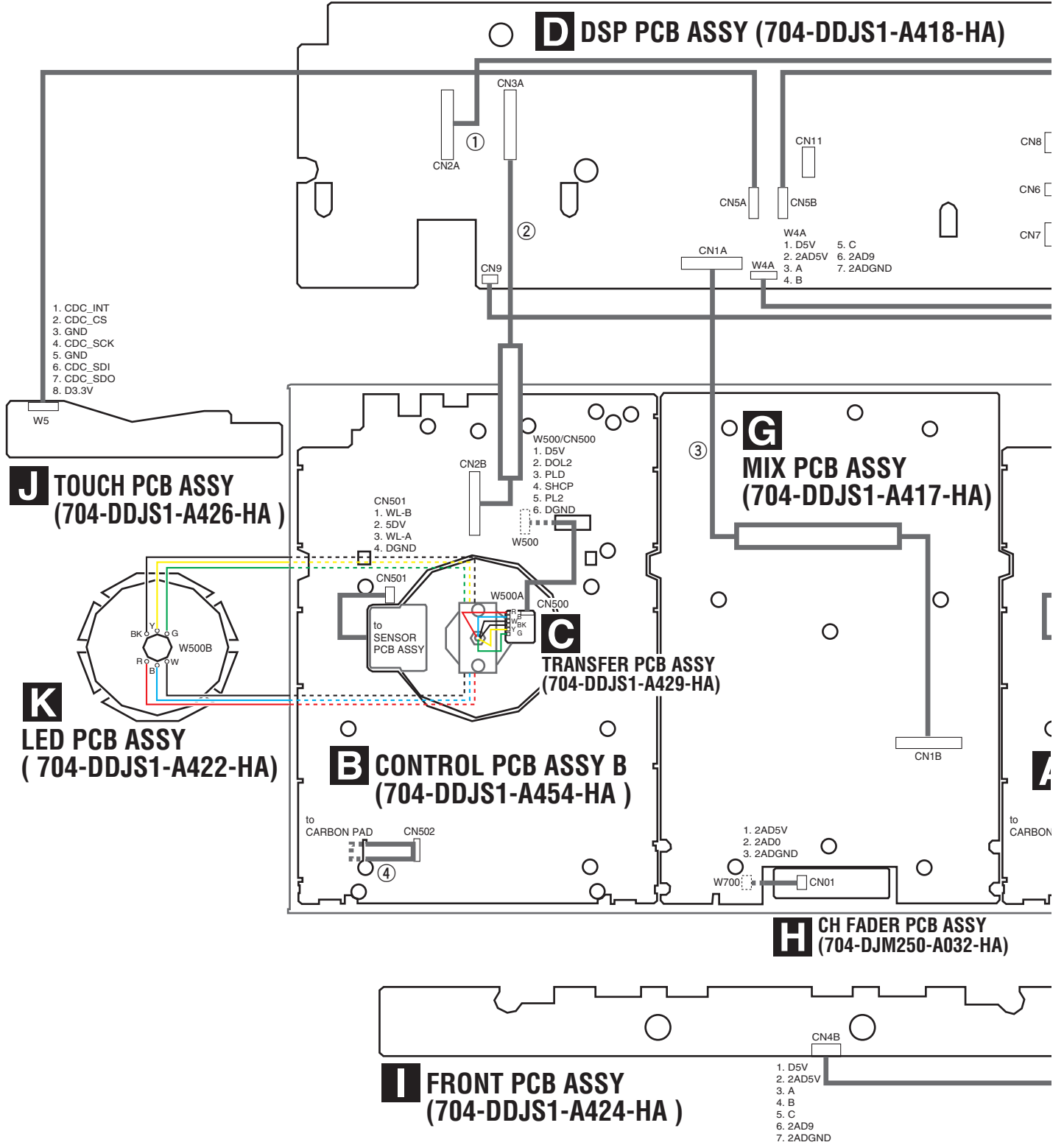

- 部品を発注する場合は、必ず「分解図と部品表」または「電気部品表」を参照してください。
- △印の部品は、安全上重要な部品です。
交換するときは、安全および性能維持のため必ず指定の部品をご使用ください。

- When ordering service parts, be sure to refer to "EXPLODED VIEWS and PARTS LIST" or "PCB PARTS LIST".
- The △ mark found on some component parts indicates the importance of the safety factor of the part.
Therefore, when replacing, be sure to use parts of identical designation.

(18-HA)

E OUTPUT PCB ASSY
(704-DDJS1-A425-HA)

F BAL. PCB ASSY
(704-DDJS1-A423-HA)

1. CDC_INT
2. CDC_CS
3. GND
4. CDC_SCK
5. GND
6. CDC_SDI
7. CDC_SDO
8. D3.3V

J TOUCH PCB ASSY
(704-DDJS1-A426-HA)

C TRANSFER PCB ASSY
(704-DDJS1-A429-HA)

K LED PCB ASSY
(704-DDJS1-A422-HA)

A CONTROL PCB ASSY A
(704-DDJS1-A421-HA)

(7-HA)

to B ASSY
(1-A032-HA)

No.	Ref No.	Description	Part No.
①		37P 1.0 FFC Cable	406-S1-1235HA
②		37P 1.0 FFC Cable	406-S1-1234HA
③		30P 1.0 FFC Cable	406-S1-1233HA
	W4A	7P CONNECTOR WIRE	404-S1-3760-HA
	W5	8P CONNECTOR WIRE	404-S1-3761-HA
	W6	3P CONNECTOR WIRE	404-S1-3754-HA
	W7	6P CONNECTOR WIRE	404-S1-3755-HA
	W8	5P CONNECTOR WIRE	404-S1-3758-HA
	W9	4P CONNECTOR WIRE	404-S1-3757-HA
	W500	6P CONNECTOR WIRE	404-S1-3759-HA
	W700	CONNECTOR WIRE	404-S1-3756-HA

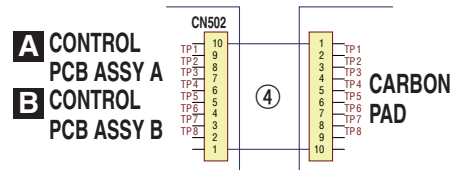
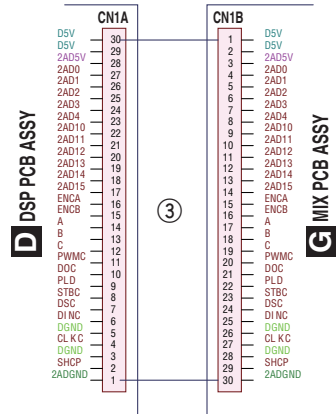
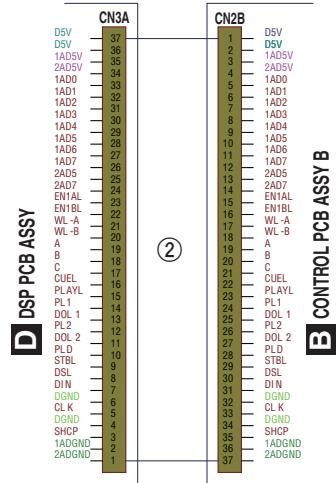
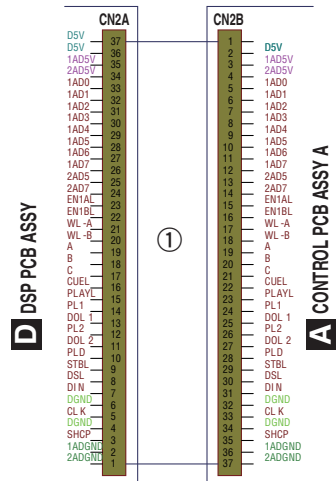

4.2 OVERALL BLOCK DIAGRAM

DSP PCB ASSY

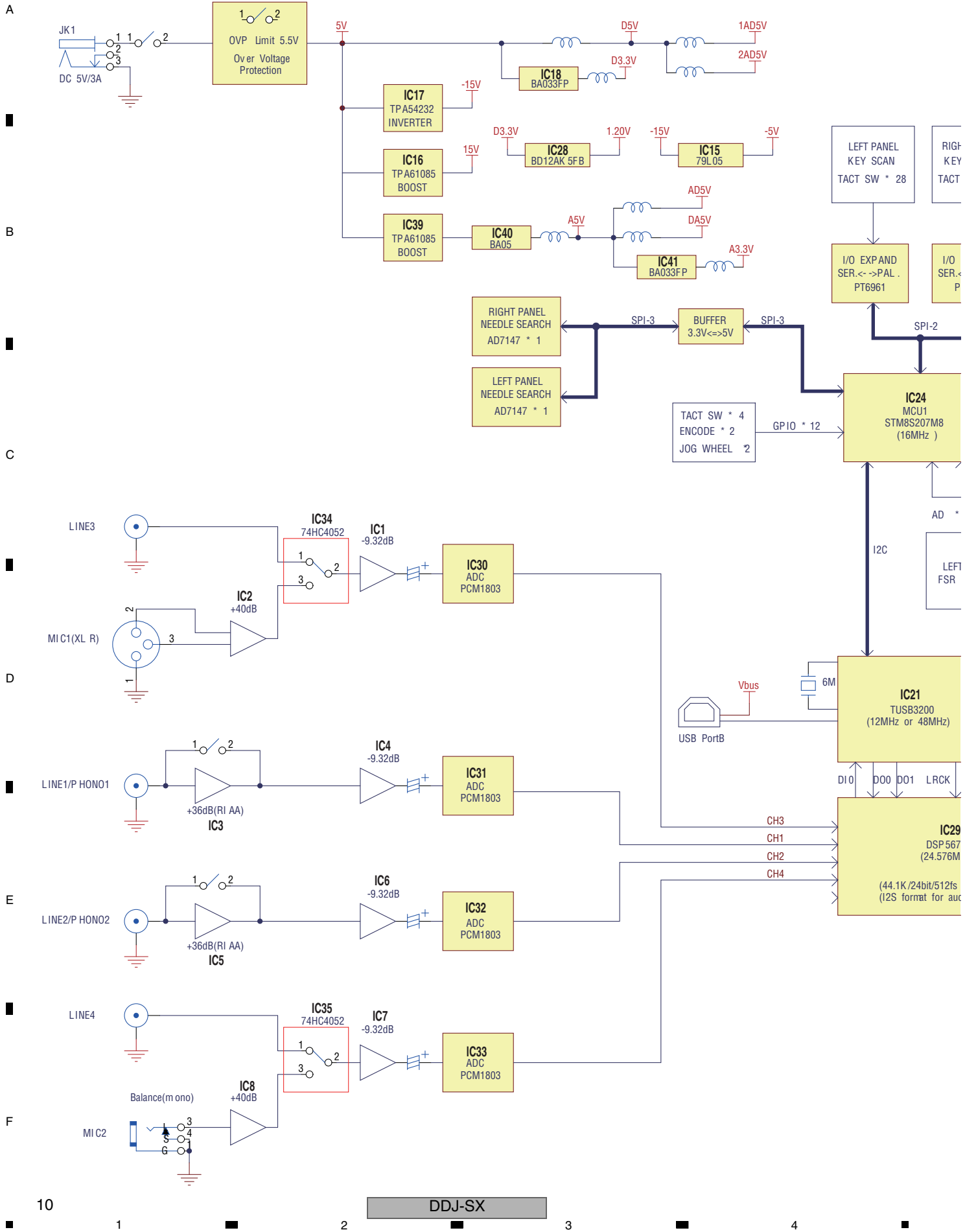

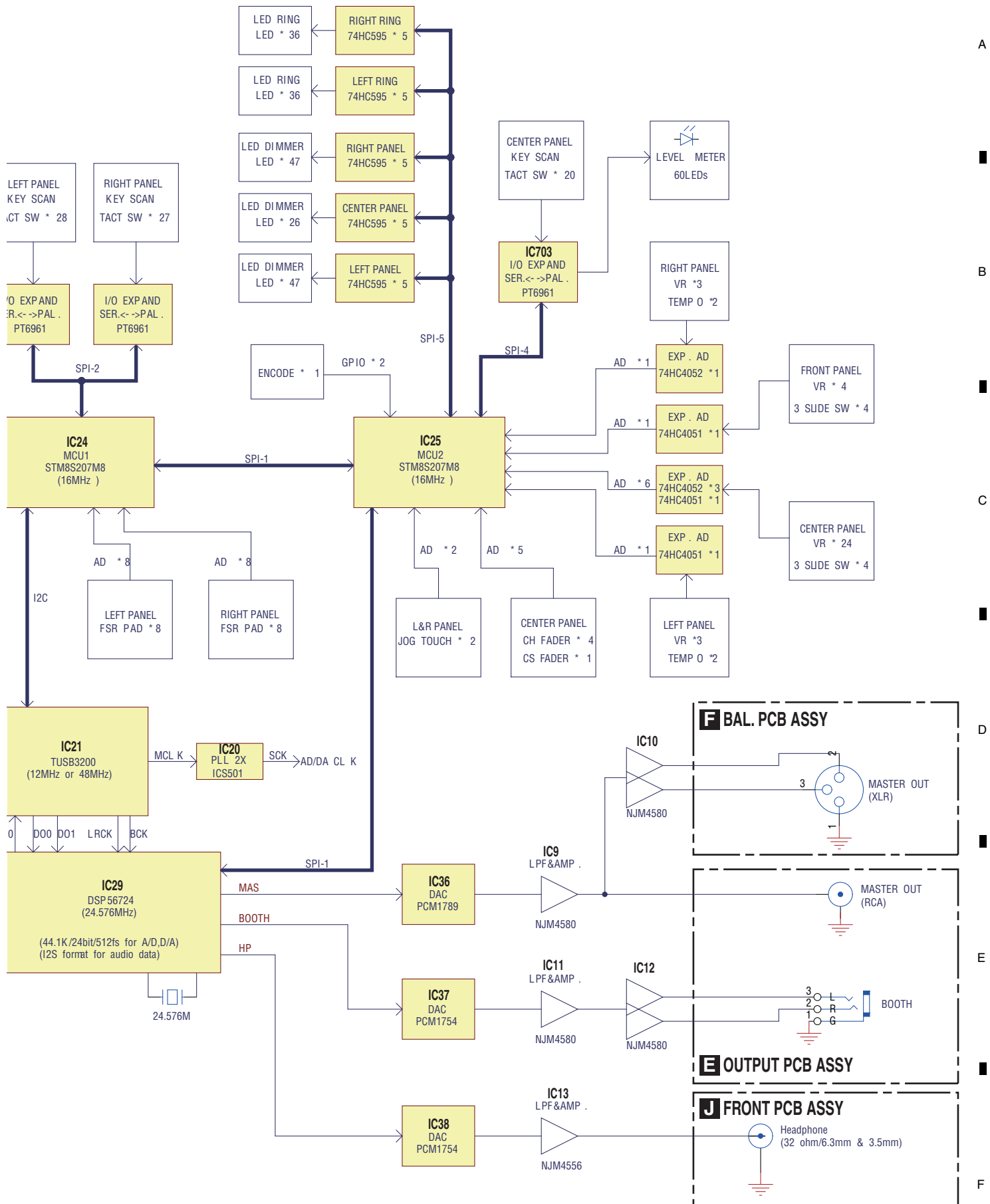

5. DIAGNOSIS

5.1 TROUBLESHOOTING

[1] Abnormality regarding startup and communications

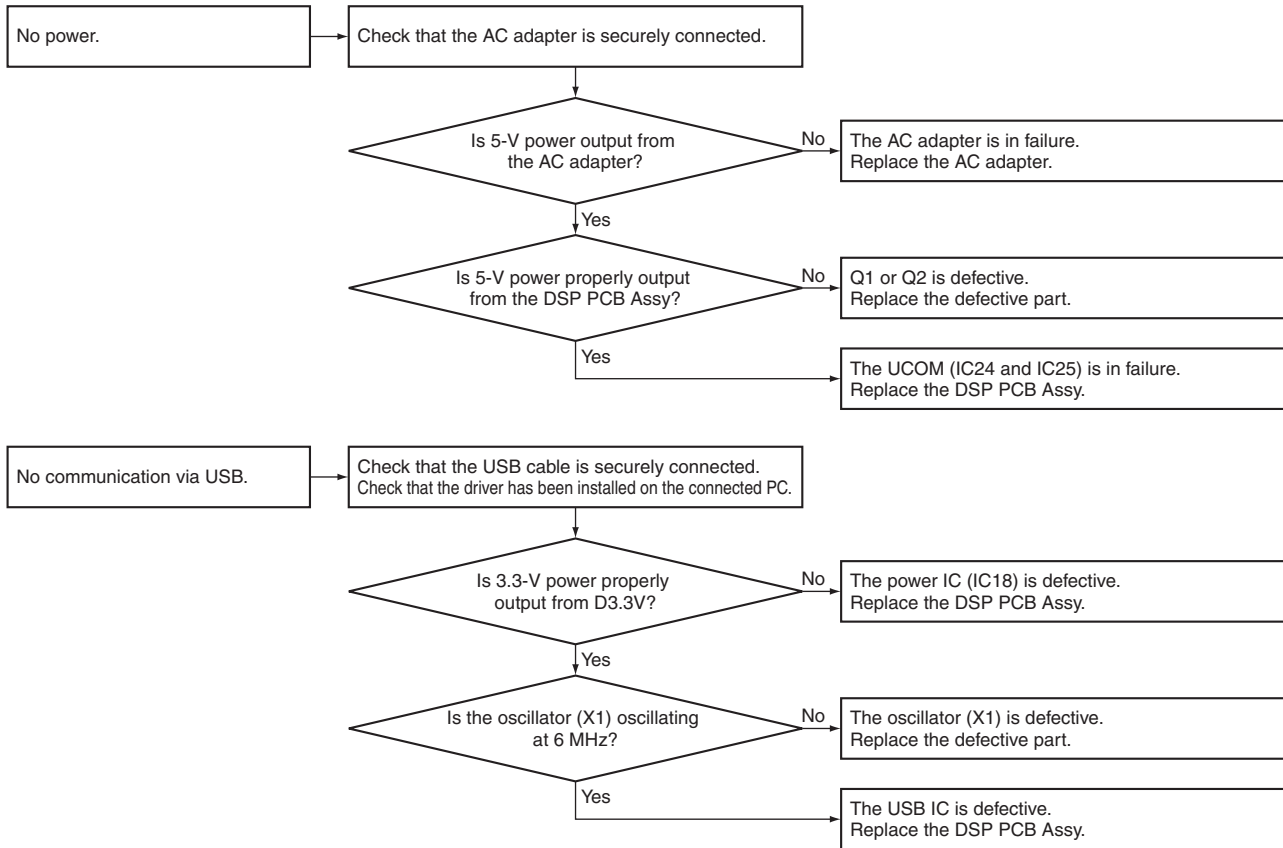

[2] Abnormality regarding the operating elements and LEDs

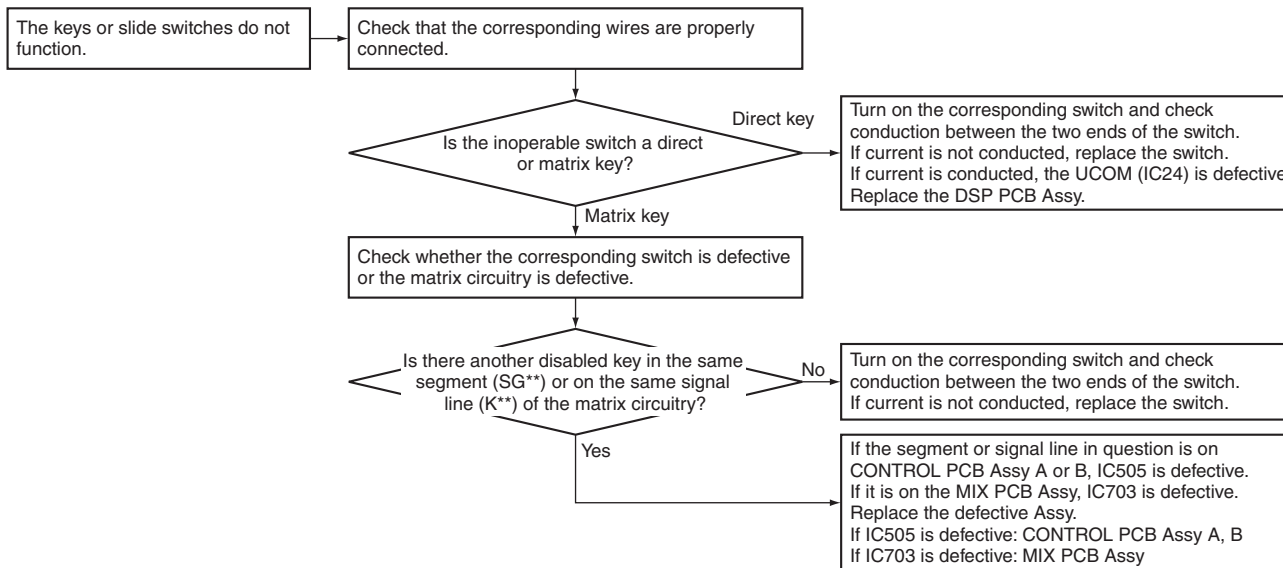

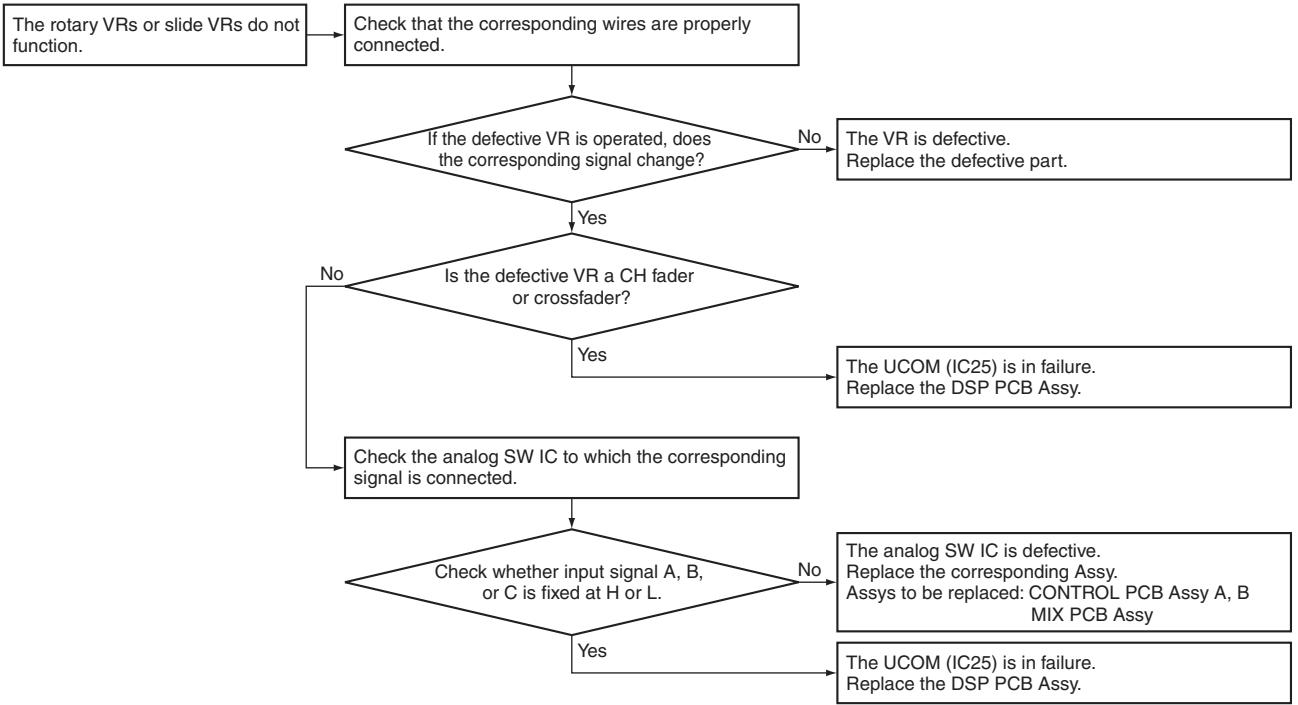

A
B
C

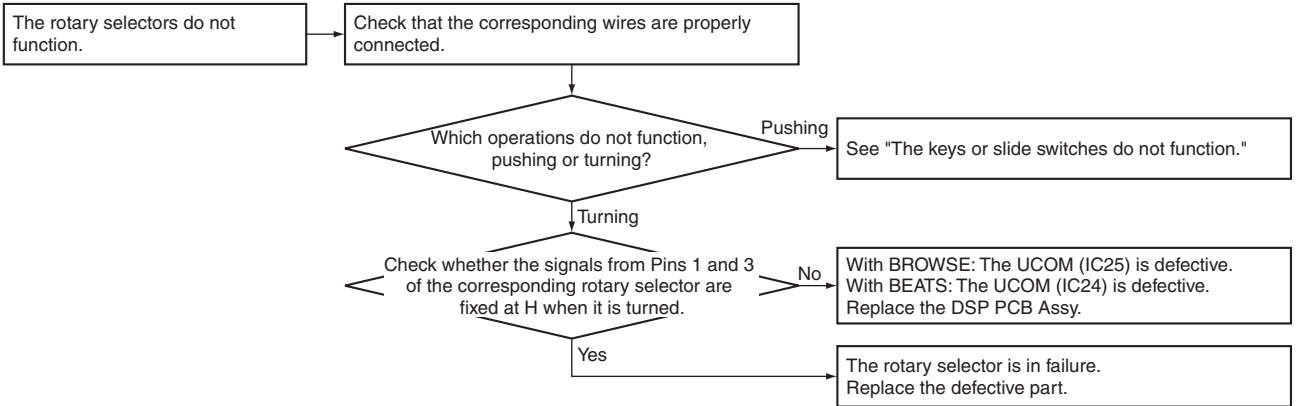

D

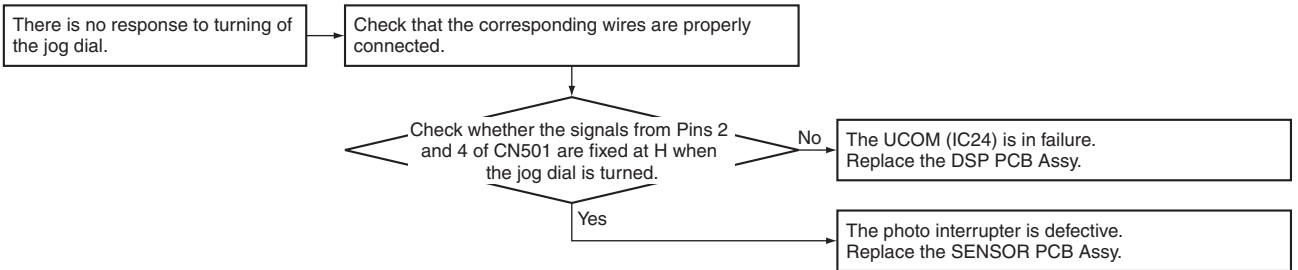

E

F

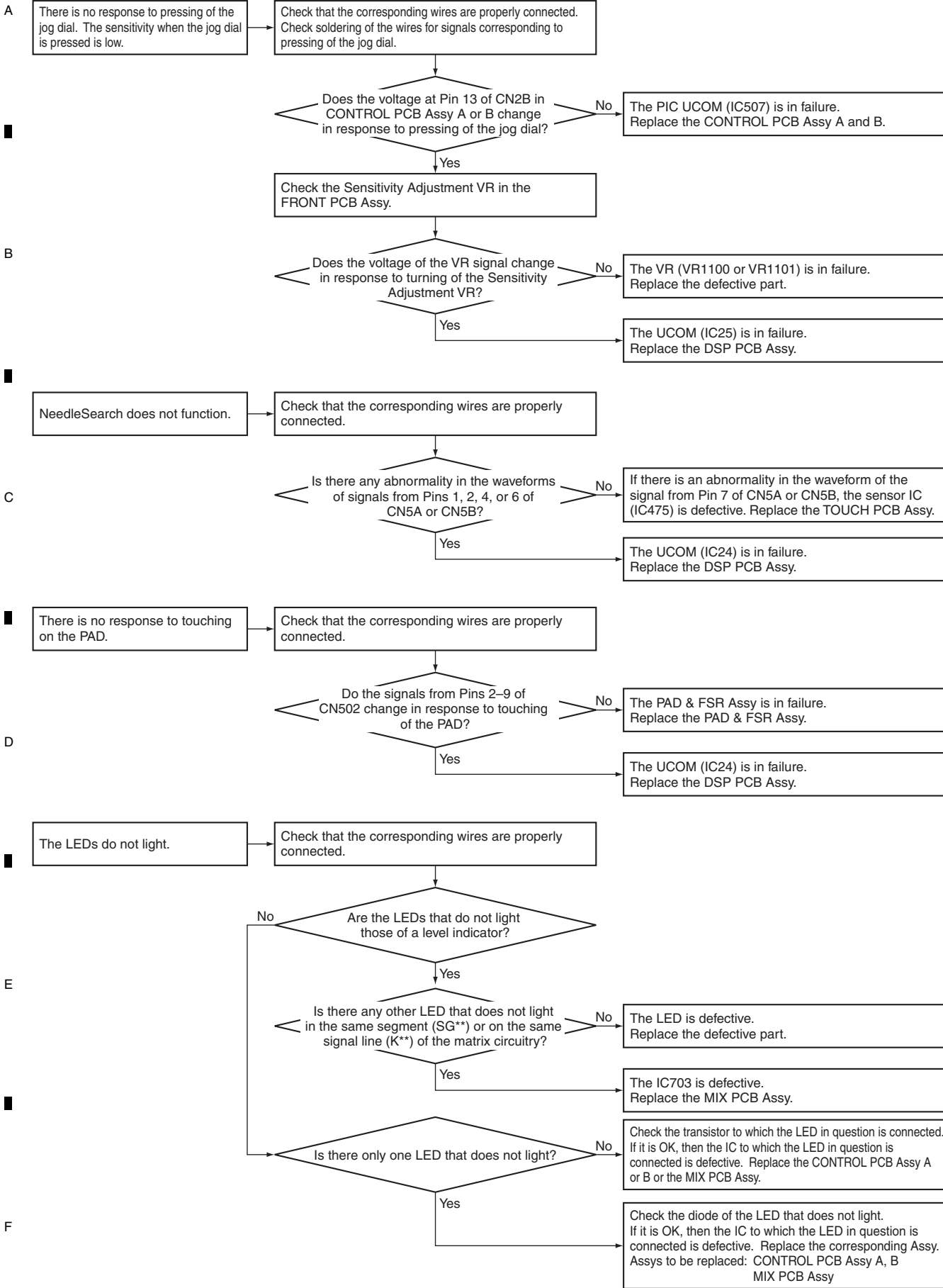

[3] Abnormality in audio input/output

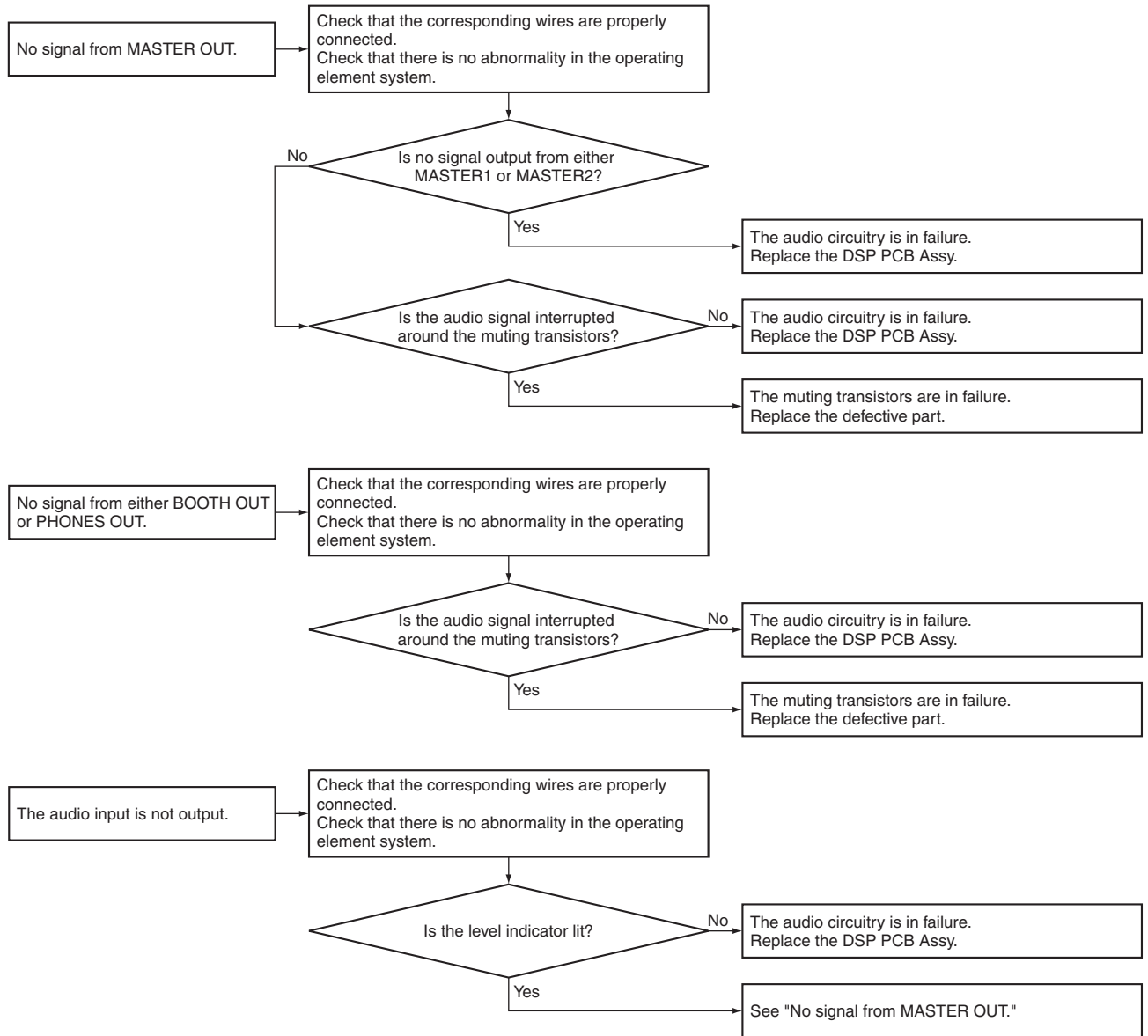

A
B
C
D
E
F

6. SERVICE MODE

6.1 SERVICE MODE

[1] Error Alarming

If unusual detection is occurred during Power on or working, Indicate notice by LED.

	Error	LED	Remarks
①	Abnormalities in FLASH-ROM of MAIN_UCOM	The "FX1 Assign" LED of Deck1 Blinks in a cycle of 1 second.	When update goes wrong and FLASH-ROM is not written correctly, it will be in this state. If the last update failed, the LED blinks when next Power-on. Perform updating again. If this error warning persists, replace the USB cable. If this error warning persists more, replace the DSP PCB Assy.
②	Abnormalities of USB controller	The "FX2 Assign" LED of Deck4 Blinks in a cycle of 1 second.	When the time when it cannot communicate with USB controller correctly although USB cable is connected at the time of starting, it will be in this state. Replace the USB cable. If this error warning persists, replace the DSP PCB Assy.

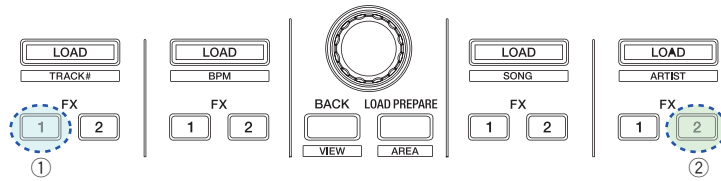

[2] Service mode

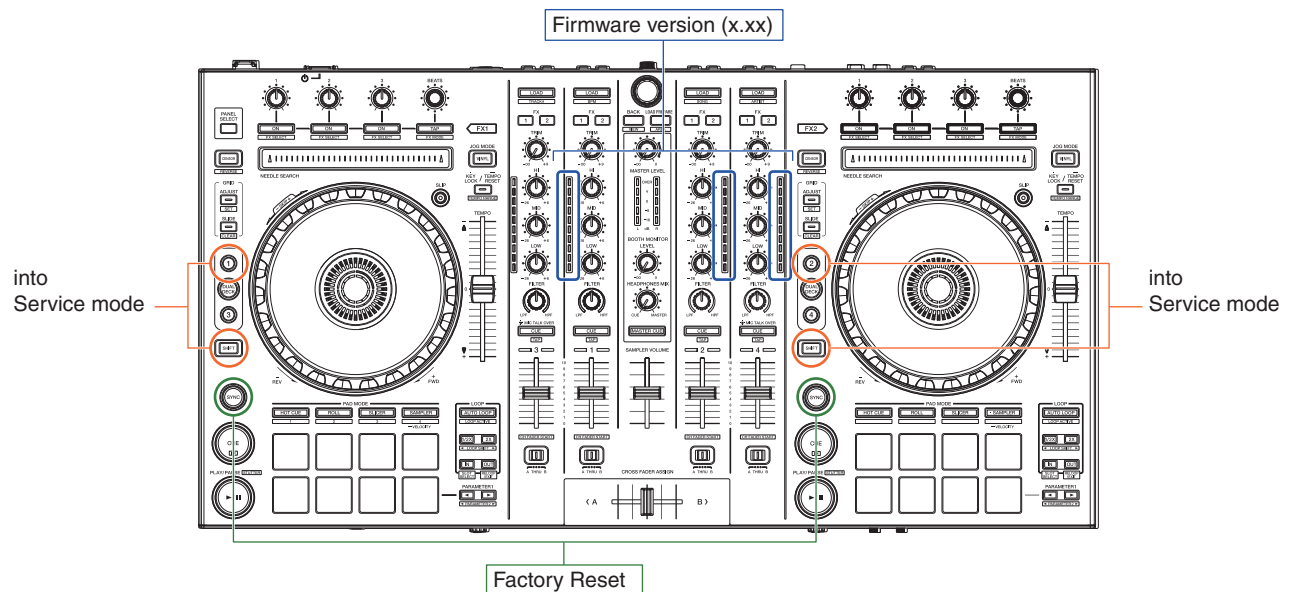

[Method to enter]

Press and hold the left DECK "SHIFT" button and the left "DECK 1" button, then Power-ON.
or

Press and hold the right DECK "SHIFT" button and the right "DECK2" button, then Power-ON.
The firmware version is displayed first. LED except it turn off.

[Method to exit]

Power-OFF

[Note]

When in this mode, the firmware version display appear first.
In this mode, it does not work to communicate with computer via USB.
In this mode, LED dimmer is not available.

1. Check of the Firmware Version

After this mode starts, the firmware version is displayed first.
The format of the firmware version is "x.xx". (x: decimal)
It is displayed by the Channel level indicators (Deck1/Deck2/Deck4).

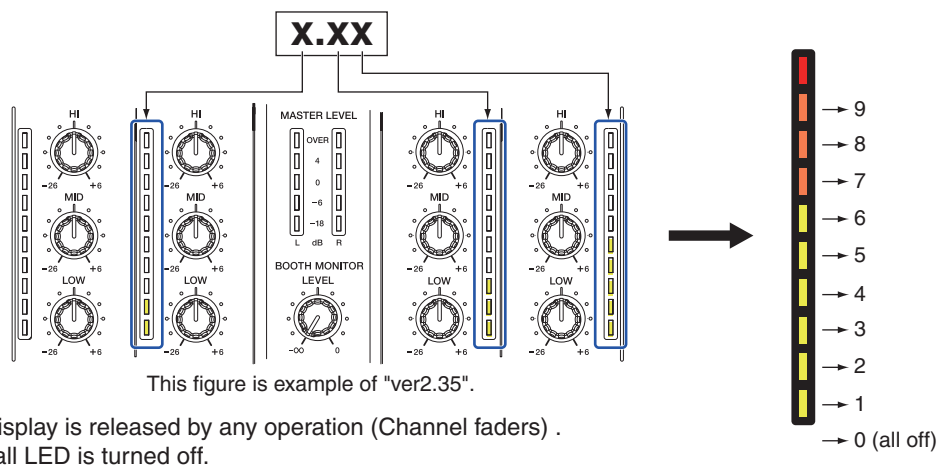

A 2. Check of UI parts & LED

After checking the firmware version, you can check if each UI parts (button/jog dial/knob/fader etc.) are not abnormal. All UI parts of top&front panel are objects to check.

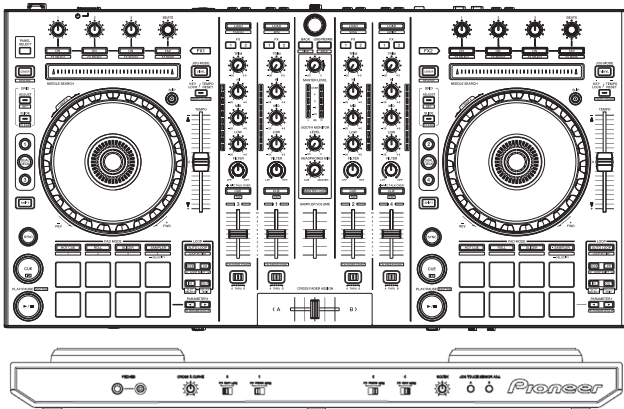

LED lighting specification for parts type

Parts type	UI Parts Name	Trigger	LED to check
Push switches (with LED)		Press	Own LED
Push switches (without LED)	"BROWSE"	Press	All LEDs and indicators
	"BACK"		CH FADER START (DECK1) LED
	"AREA"		SYNC (DECK2) LED
	"JOG (touch)"		"Jog dial center LED" all on
	"PANEL"		"REV"LED
	"SHIFT"		"HOT CUE" LED
Rotary knob, jog dial (rotate)		Turn	"Jog dial center LED" TYPE-A (*1)
NEEDLE SEARCH Pad, Cross fader, TEMPO slider		Slide	"Jog dial center LED" TYPE-B (*2)
Channel fader		Slide	Each channel level indicator (*3)
Slide switch	CRF ASSIGN SW	Slide	Jog dial center LED TYPE-A (*1)
	INPUT SELECT SW		

[Note]

In case of the left parts, the left parts LED are lit.
 In case of the right parts, the right parts LED are lit.
 In case of the center parts, the right&left parts LED are lit.
 The indication corresponding to a pressed button is lit only while the button is held pressed.
 (Press and hold the left LOOP"IN" button and the left "F2" button then power-on. Keep it until opening illumination is terminated.)

(*1) TYPE A (Rotary knob, Jog dial)

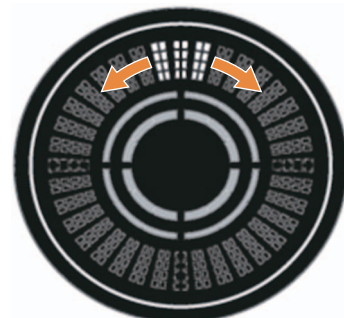
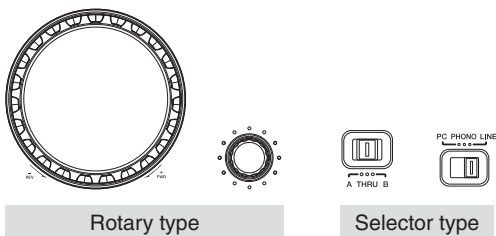

In case of the rotary type (knobs, jog dial), LED are assigned 360 degree in 36 steps.
 In case of the selector type, LED are assigned 1 click by 1 step.
 The starting position depends on the last position.
 One unit to light consists of three LED and they are always lit.

(*2) TYPE B (Volume knob, NEEDLE SEARCH Pad, Cross fader, TEMPO slider)

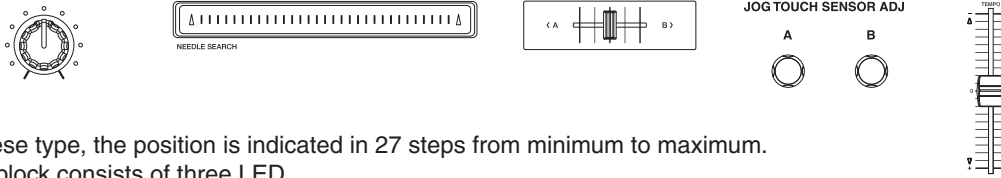

In these type, the position is indicated in 27 steps from minimum to maximum. One block consists of three LED.

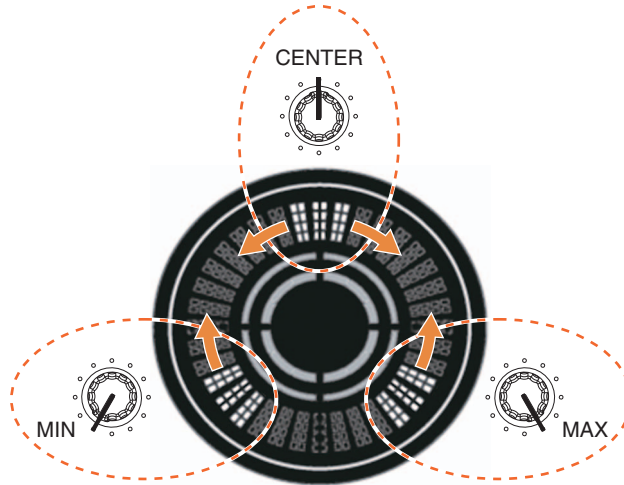

(*3) Check for Channel fader

In channel fader, the position is indicated in 11 steps from minimum to maximum. The each channel fader (Deck1 - Deck4) is indicated at own Channel level indicator. (CH1 → CH1 level indicator, CH2 → CH2 level indicator, etc.)

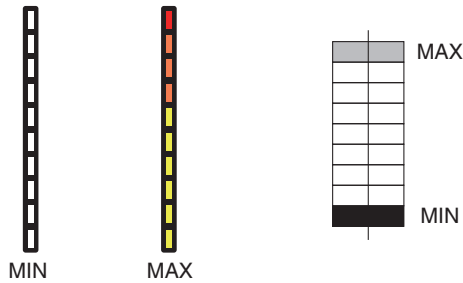

3. Factory Reset

The following data is reset to the factory default settings by "Factory reset" operation.

- Setting data in Utility mode
- Last memory of users

[Method to reset]

Press and hold the left DECK "SYNC" button and the right DECK "SYNC" button for 5 seconds. Then factory reset starts and "SYNC" LEDs are lit. After completing reset, "SYNC" LEDs are turned off.

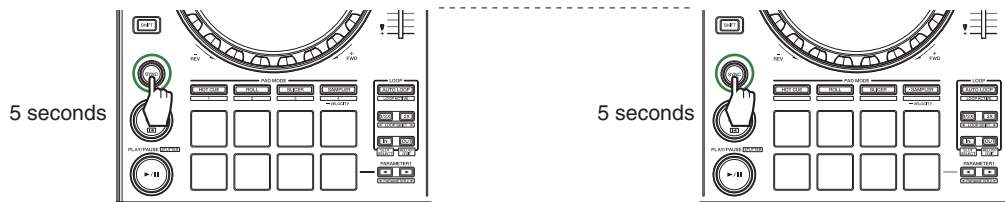

A [3] Measurement mode

This is the mode to measure jog dial rotation time and the fluctuation of knobs/faders.

- (1) Jog dial Rotation Time measurement mode
- (2) Volume value fluctuation check mode

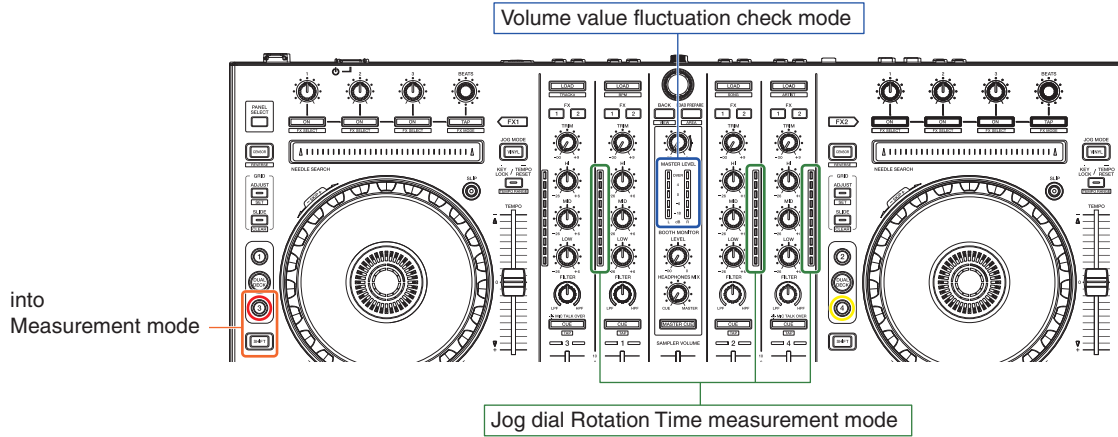

[Method to enter]

Press and hold the "SHIFT"+"DECK3" buttons then Power-ON.
 During this mode, "DECK 3" and "DECK 4" LEDs are lit.

[Method to exit]

Power-OFF

(1) Jog dial Rotation Time measurement mode

This is the mode to measure the JOG rotation time which is specified at "Jog dial Performance specification".

In case of the left jog dial, the result are displayed at the left LEDs.
 In case of the right jog dial, the result are displayed at the right LEDs.
 The specified range is 100 ± 40 msec.

[Method to measure]

- ① You spin Jog dial more than $33 \times 7 = 231$ rpm.
 *1 In case of less than 231 rpm, it is failure. Then "SLIP" LED is lit.
 *2 You must measure by either clockwise or counterclockwise.
- ② The controller measures "T1".
 *T1: The time that Jog dial rotation speed slow down from 100 rpm to 50 rpm.
- ③ The controller display result with three Channel level indicators. Refer to below.
 The format of the result is "XXX" msec. (X: 0-999 msec .decimal)
 It is displayed by the Channel level indicators (Deck1/Deck2/Deck4).

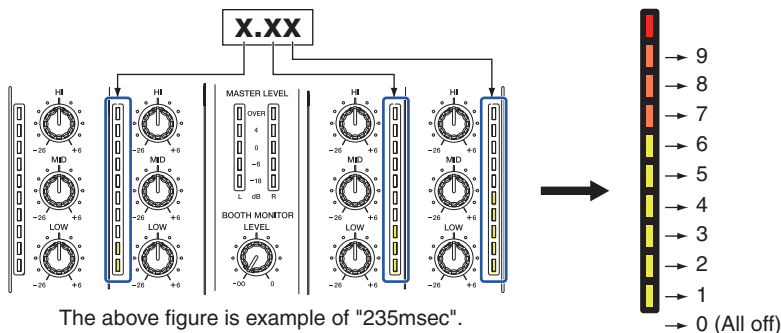

(2) Volume value fluctuation check mode

[Overview]

Will be tested fluctuation of voltage (A/D conversion value) which is made each Fader and Rotary volume by Master level indicator.

[Use of this mode during repair]

- For failure judgment of the rotary VRs
 - As a guide, amplitude values higher than +4 or lower than -4 may be judged as failure.
 - The VRs can be set to any position during measurement. Possible symptoms are shown below.
- The volume changes arbitrarily.
- Interrupted sound leakage occurs even if the volume is decreased to the minimum at the Master or Booth Monitor.
- The MIDI signal is output even if the corresponding VR is not operated.
- For operation check of a rotary VR after replacement

[Knobs under test operation]

Knobs under test operation are filled blue as below.

Test subjects to move by turning right / left-turn Rotary selector.
A/D conversion value observation start/reset by push the Rotary selector.

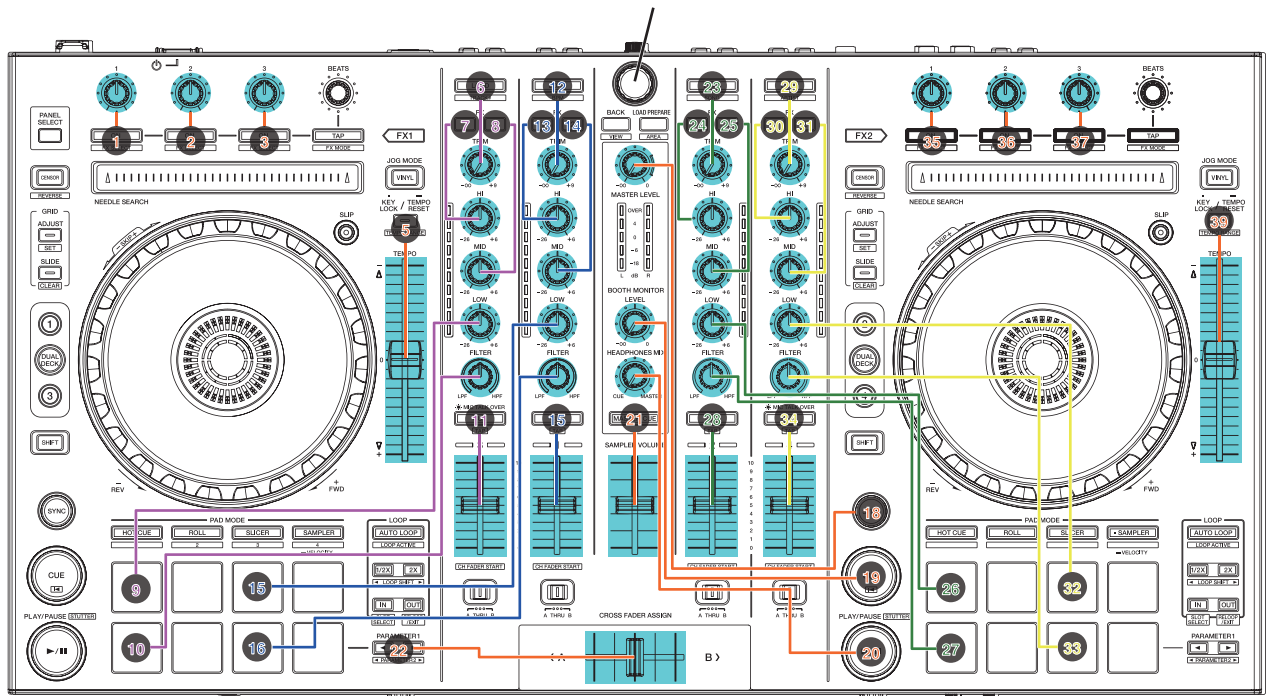

[Test detail]

- ① Choose the test subject by turn left and right Rotary selector.
The LED is lit with the following turns every 1 click.
Turn right: 1 → 2 → 3 → 5 → → 37 → 39 → 1 → . . .
Turn left: 39 → 37 → 36 → → 2 → 1 → 39 → . . . (No.4 and 38 were deleted)
Note: Regarding No.22, both LED are lit.
- ② You can see what knob/fader is selected by Lighting LED on each button as shown in the above figure.
For example ,LED to test "SAMPLER VOLUME" fader is "MASTER CUE" button's LED.
- ③ When targeted knob is decided, push the Rotary selector and start observation of A/D conversion value.
Get the A / D conversion value immediately after the start. It will be reference value.
*A/D conversion value to be monitored is Raw data.
- ④ Start monitoring and later to monitor the A/D conversion value, do the following actions depending on its value with Master level indicator.

Result	Fig No.
+1 from the reference value A/D conversion value	1
+2 from the reference value A/D conversion value	2
+3 from the reference value A/D conversion value	3
+4 from the reference value A/D conversion value	4
Over +5 From the reference value A/D conversion value	5
-1 from the reference value A/D conversion value	6
-2 from the reference value A/D conversion value	7
-3 from the reference value A/D conversion value	8
-4 from the reference value A/D conversion value	9
Less than -5 from the reference value A/D conversion value	10

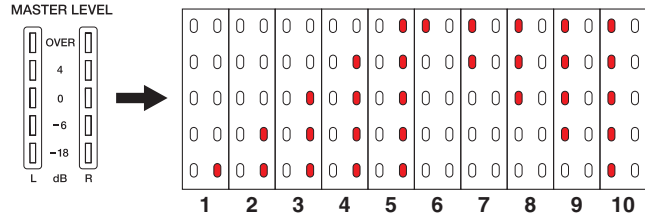

B * Display at the same time both fall / rise direction from the reference value of the conversion value A/D.

* Keep the lighting position at the time of maximum fluctuation of each of the positive & negative direction

⑤ By pushing the Rotary selector while monitoring the conversion value A/D, it is possible to reset the state of the fluctuations of the past.

Ex.)

1. Turn EQ HI knob (for DECK 1) to the position you want to measure.

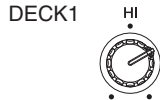

2. Turned right 11 clicks Rotary selector. → "FX1 assign" LED of the DECK 1 is lit.

3. Start A/D conversion value monitoring to push Rotary selector. If A/D value of push the Rotary selector is 760, to monitor the amount of change in the value of A/D as a reference value 760.

4. After a while, Master level indicator is lit as follows: become the value 763 of the A/D.



5. More time has elapsed, to maintain the above display 762 even though the value of the A/D.

6. More time has elapsed, Master level indicator is lit as follows: become the value 764 of the A/D.



7. More time has elapsed, Master level indicator is lit as follows: become the value 758 of the A/D.



8. More time has elapsed, To maintain the above display 759 even though the value of the A/D.

9. More time has elapsed, Master level indicator is lit as follows: become the value 757 of the A/D.



10. Off all the LED on Master level indicator When you push the Rotary selector, and this value will be new reference value.

7. DISASSEMBLY

Note: Even if the unit shown in the photos and illustrations in this manual may differ from your product, the procedures described here are common.

Disassembly

[1] DSP and OUTPUT PCB Assemblies

• Base

- (1) Remove the Base by removing the 21 screws.
(602-PTP3012-571-HA)

Screw tightening order

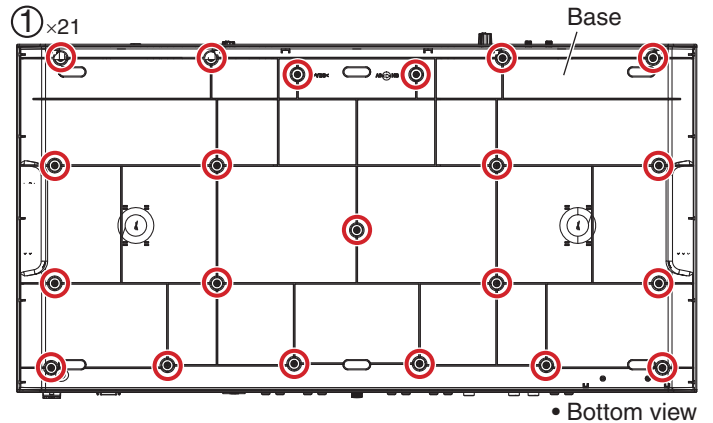
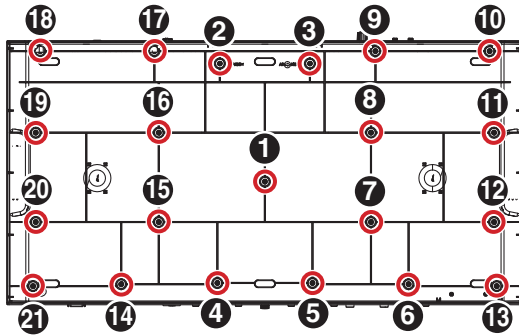

• Shield

- (1) Remove the two screws.
(602-MP3-324-HA)
- (2) Remove the Isolation plate by removing the two screws.
(602-B600-072-HA)
- (3) Remove the two screws.
(602-SL24F-099-HA)
- (4) Remove the one screw.
(602-QMX2BPM-322-HA)
- (5) Remove the Cover by removing the one screw.
(602-B600-072-HA)

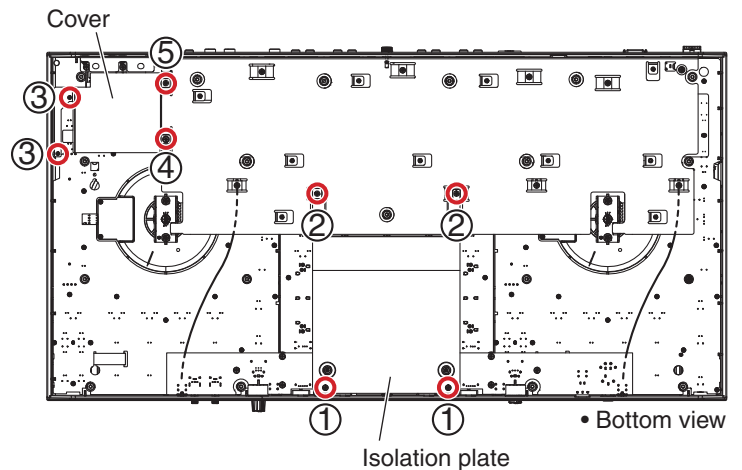

• DSP and OUTPUT PCB Assemblies

- (1) Remove the Strain relief bush by removing the one screw.
(602-BTB3012-446B-HA)
- (2) Remove the four screws.
(602-MP3-324-HA)
- (3) Remove the Ground terminal and washer.

Screw tightening order

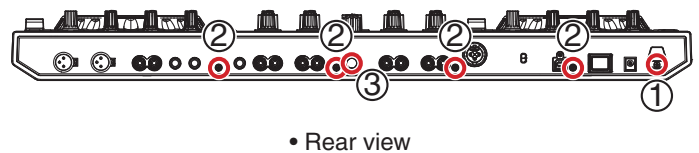
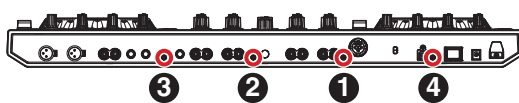

- A (4) Cut the binder
- (5) Disconnect the one flexible cable and two connectors. (CN1B, CN4B, W9)
- (6) Remove the Output board by removing the eight screws. (602-B600-072-HA)

Screw tightening order

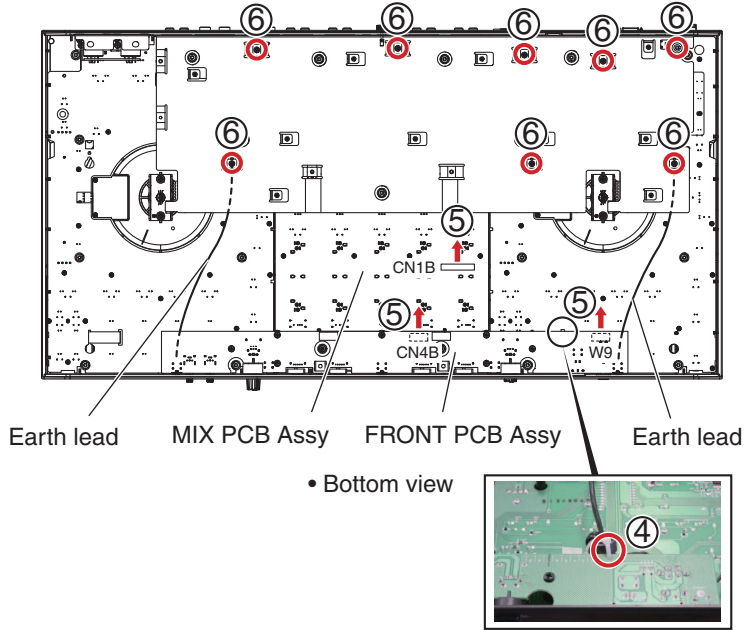
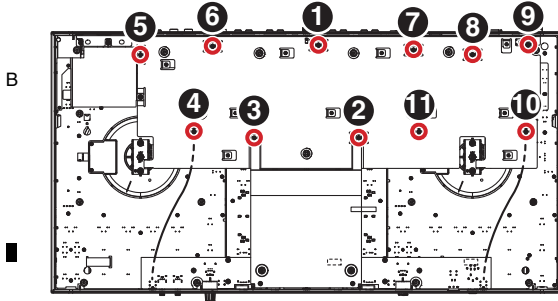

C



- D (7) Disconnect the two flexible cables and three connectors. (CN2Bx2, CN5A, CN5B, CN7)

Screw tightening order (reference information)

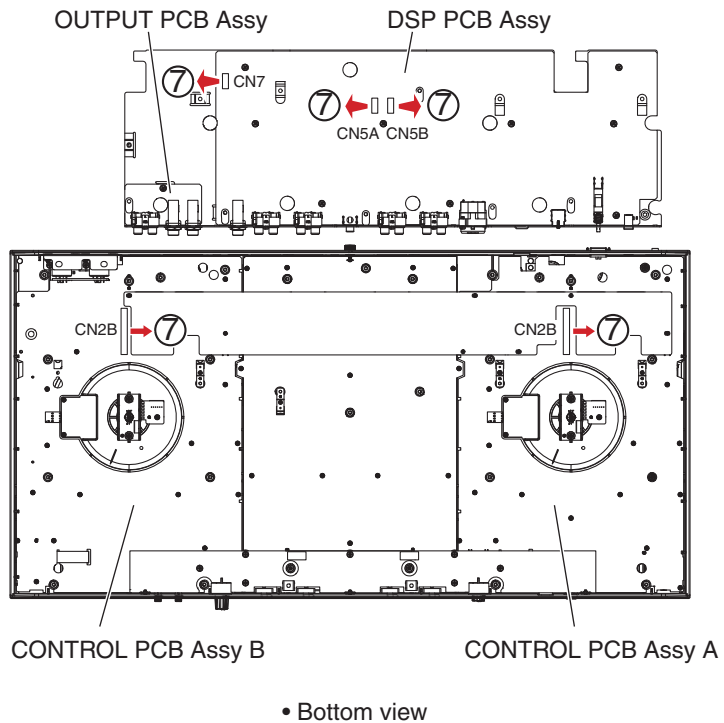
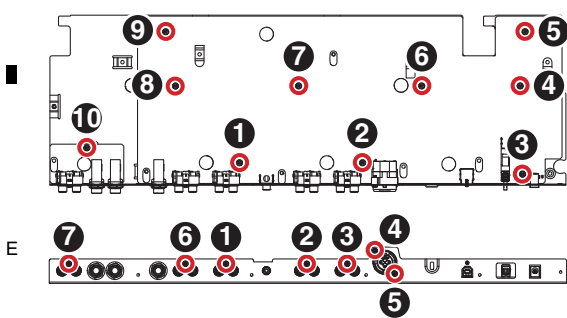

F



[2] Jog dial section

Note:

A figure is only left DECK side, but the right side is similar, too.

• SENSOR PCB Assy

- (1) Remove the Dust-proof slice by removing the two screws.
(602-PROS2-363-HA)

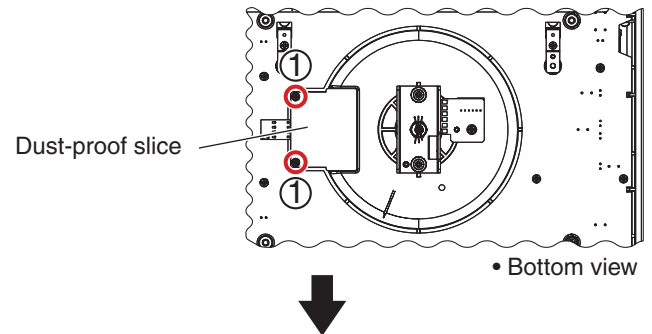

- (2) Disconnect the one connector.
(CN501)
- (3) Remove the Sensor fixed plate by removing the two screws.
(602-DJ5500-452-HA)
- (4) Remove the SENSOR PCB Assy.

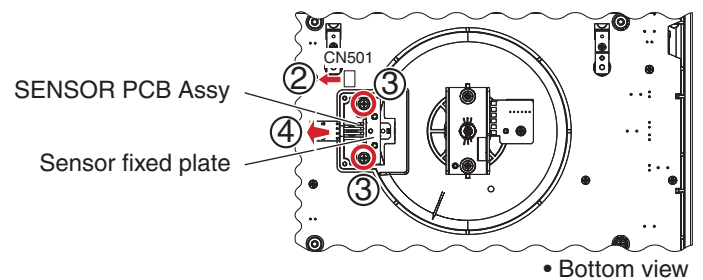

• Jog dial section

- (1) Remove the six solders.
- (2) Remove the one nut and one washer.
- (3) Remove the JW LED base by removing the two screws.
(602-3113-122-HA)

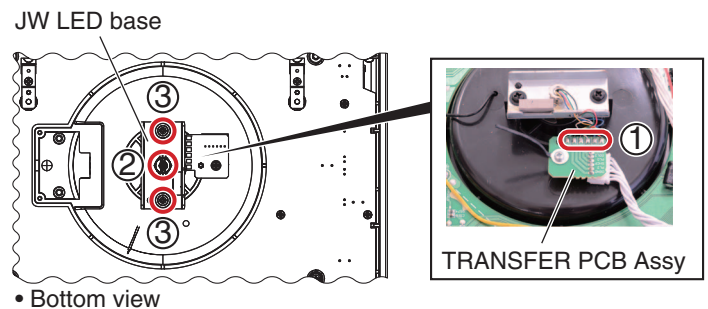

- (4) Remove the one E ring.

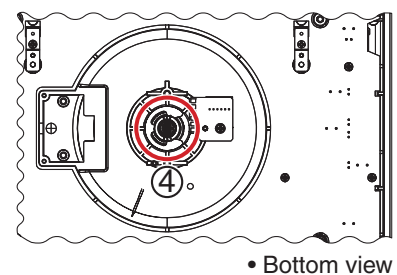

A (5) Remove the jog dial section.

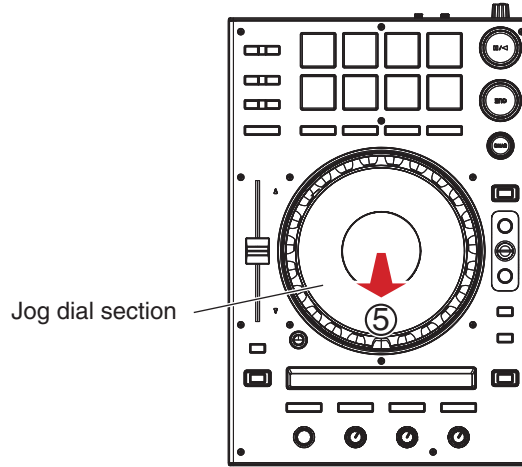

B

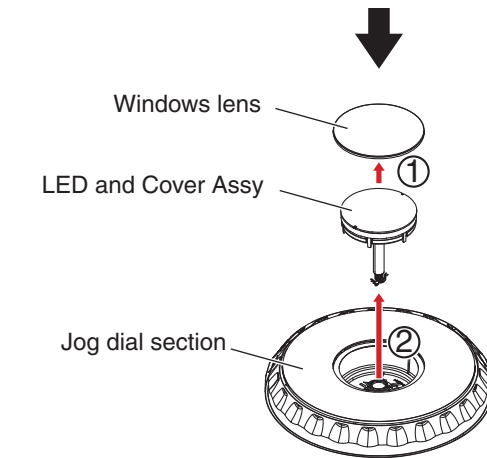

• LED PCB Assy

(1) Remove the Windows lens.
Insert a slim rod in the hole for disassembly in the jog dial section bottomsides, and remove it.

C

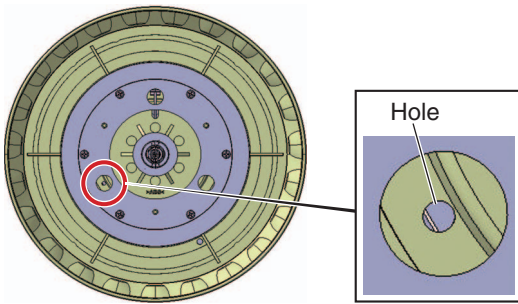

• Bottom view

D (2) Remove the LED and Cover Assy.

(3) Remove the JW cover by unhooking the six hooks.

(4) Remove the LED PCB Assy.

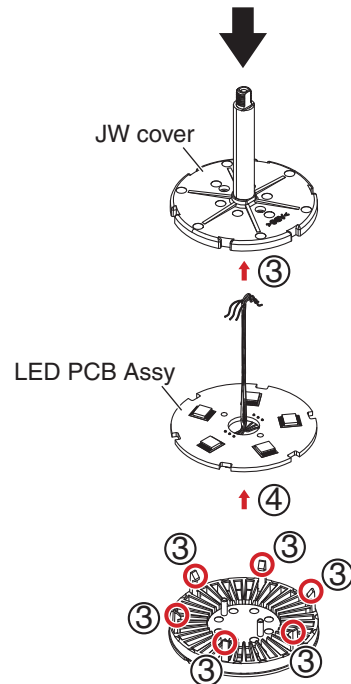

• Bottom view

F

[3] Each PCB Assemblies

Note:

When you remove each PCB Assemblies, it is not necessary to remove a jog dial section.

• CH FADER PCB Assy

- (1) Remove the Push button.
- (2) Remove the CF board by removing the two screws.
(602-CTF3010-698B-HA)
- (3) Remove the CH FADER PCB Assy.

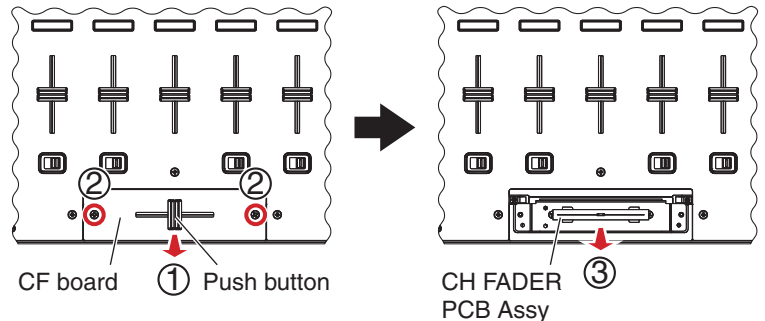

- (4) Disconnect the one connector.
(CN01)

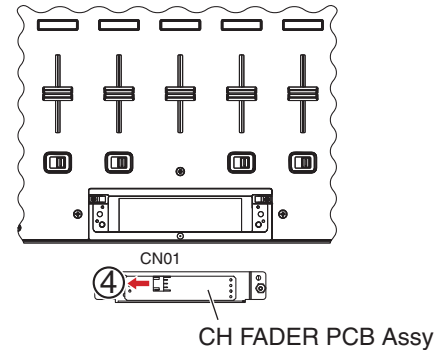

• BAL. PCB Assy

- (1) Remove the BAL. PCB Assy by removing the two screws.
(602-DJ5500-452-HA)

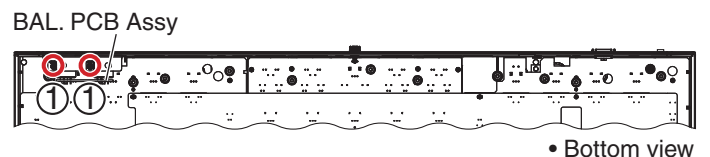

• FRONT PCB Assy

- (1) Remove the two Gain rotate knobs.
- (2) Remove the three screws.
(602-MP3-324-HA)
- (3) Remove the FRONT PCB Assy by removing the seven screws.
(602-DJ5500-452-HA)

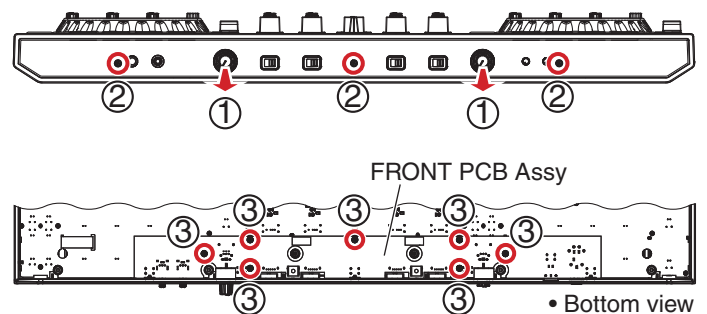

Screw tightening order

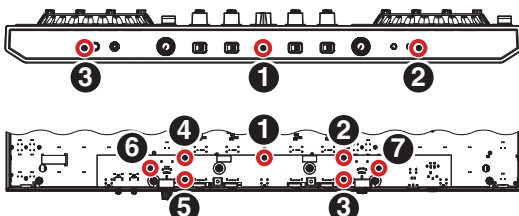

A • CONTROL and MIX PCB Assemblies

(1) Remove the all knobs.

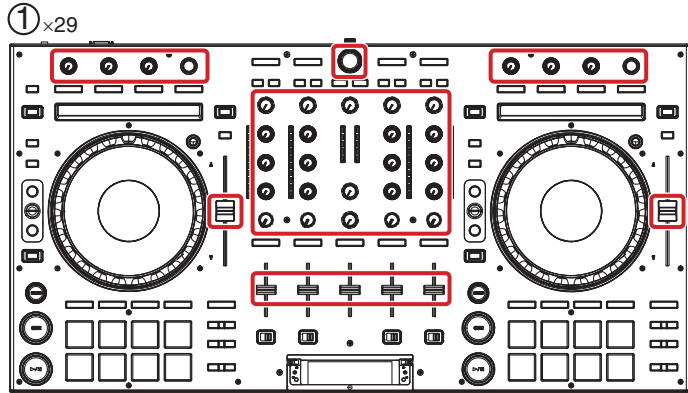

B

(2) Remove the Front panel by removing the 33 screws. (602-HP1010K-182-HA)

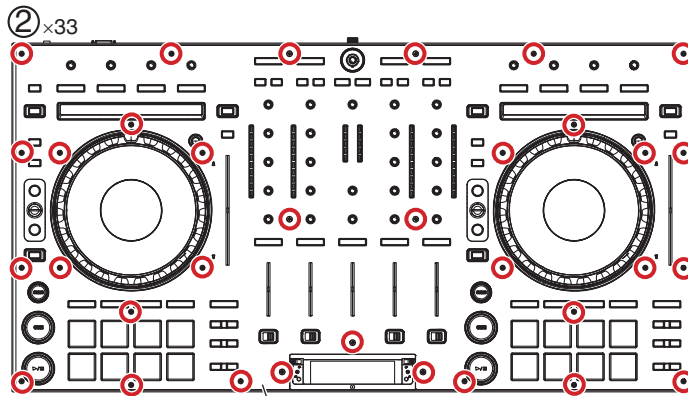

Front panel

D

■ About the double-back tape that is used for securing the front panel and the Chassis Assy

Applicable models by destination

For UXECB: SER1101 or later

For FLPXE: SER0151 or later

Other destinations: From first production

When detaching the front panel

The front panel and the Chassis Assy are secured with 4 pieces of double-back tape at the locations shown in the photo below. Slowly peel off the tape, taking care that you will not deform the front panel.

When reattaching the front panel

① Neatly remove any residue of double-back tape from the back of the front panel and the Chassis Assy.

② Stick 4 pieces (5 mm x 40 mm) of NITTO No. 500 double-back tape to the locations shown in the photo below then remove the paper liner.

Note: Even if double-back tape was not used in the initial state, be sure to attach double-back tape when reattaching the front panel.

E

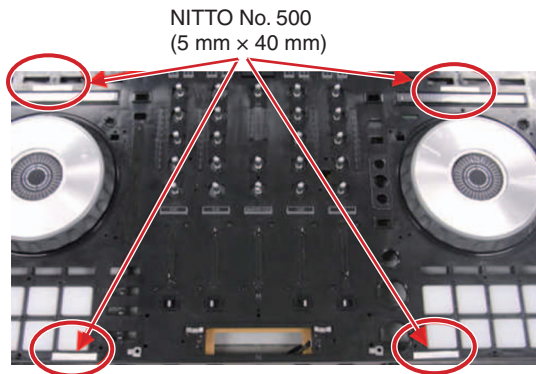

F

- (3) Remove the 22 nuts and 22 washers.
- (4) Remove the 10 screws.
(602-2002-077-HA)

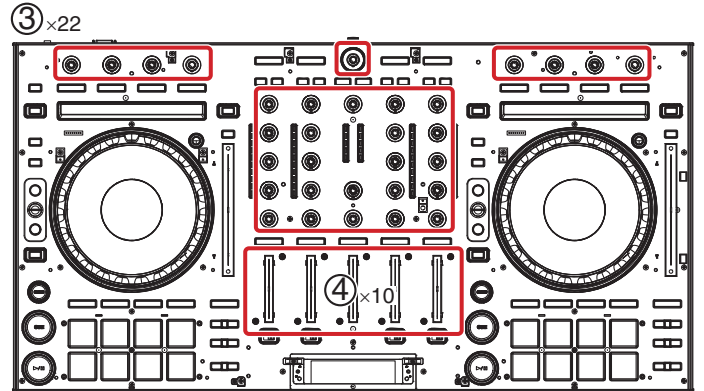

- (5) Remove the Isolation slice by removing the five screws.
(602-SL24F-099-HA)
- (6) Remove the Ground plate by removing the four screws.
(602-SL24F-099-HA)
- (7) Disconnect the two flexible cables and four connectors.
(CN500x2, CN501x2, CN502x2)
- (8) Remove the two solders.

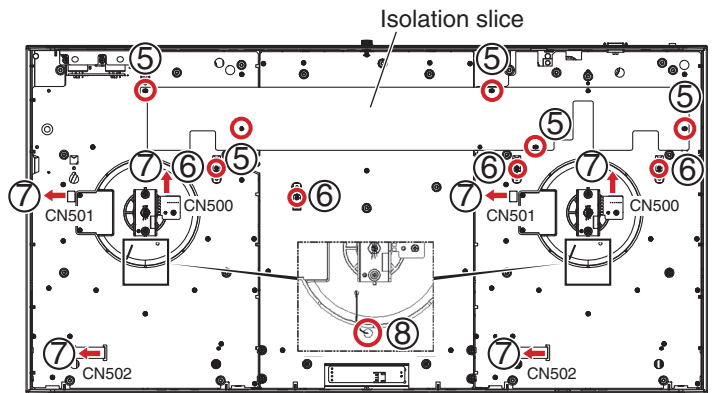

• Bottom view

- (9) Remove the MIX PCB Assy by removing the 14 screws.
(602-SL24F-099-HA)
- (10) Remove the CONTROL PCB Assy A by removing the 18 screws.
(602-SL24F-099-HA)
- (11) Remove the CONTROL PCB Assy B by removing the 17 screws.
(602-SL24F-099-HA)

Screw tightening order

The other screws are random order.

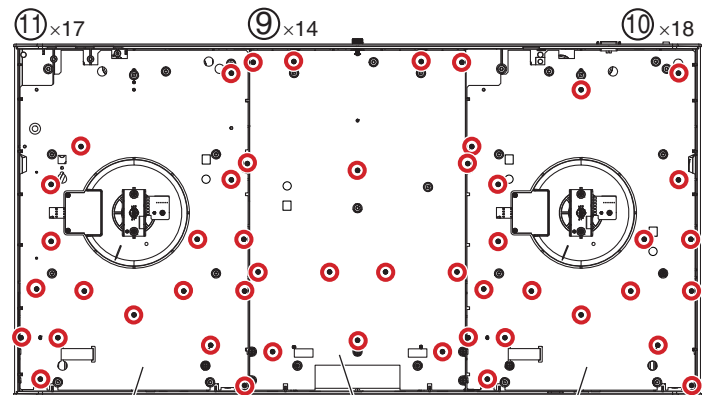
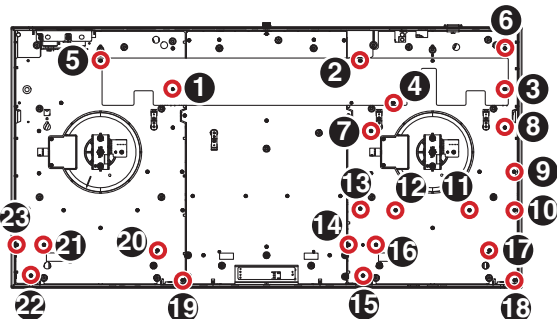
CONTROL
PCB Assy B

MIX PCB Assy

CONTROL
PCB Assy A

• Bottom view

A • TOUCH PCB Assy

(1) Remove the two TOUCH PCB Assemblies by removing the six screws. (602-B600-057-HA)

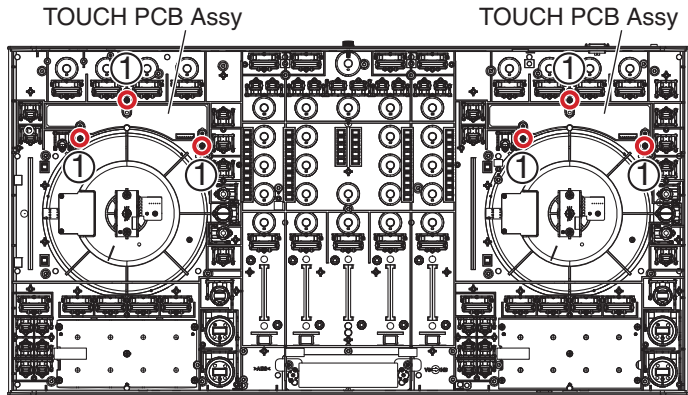

• Bottom view

The Application Position of Adhesive and Grease

C

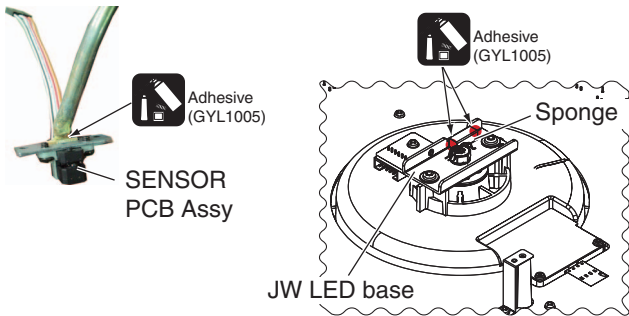

D

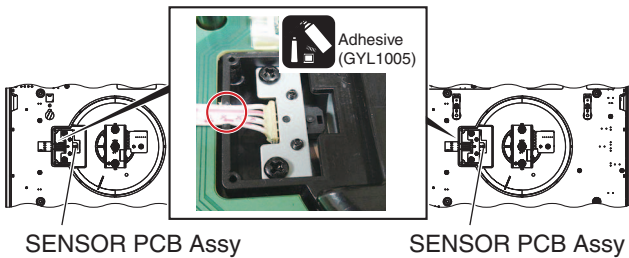

E

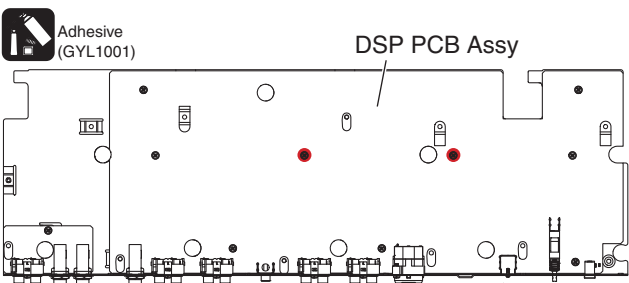

F

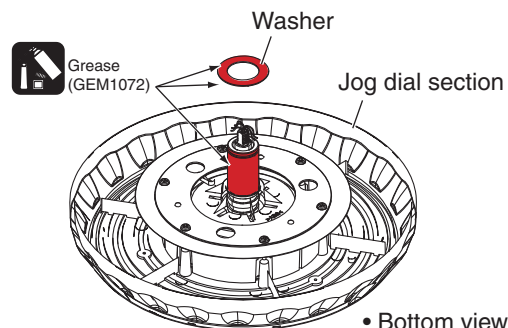
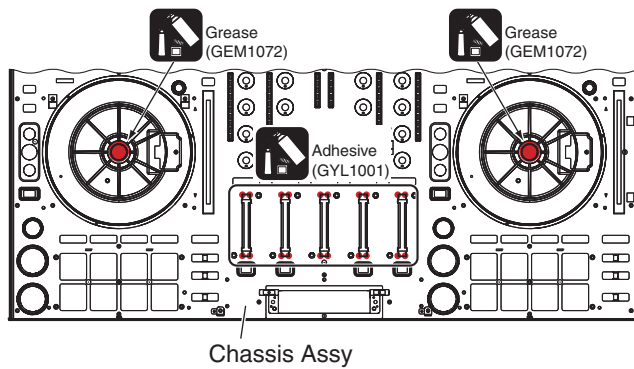
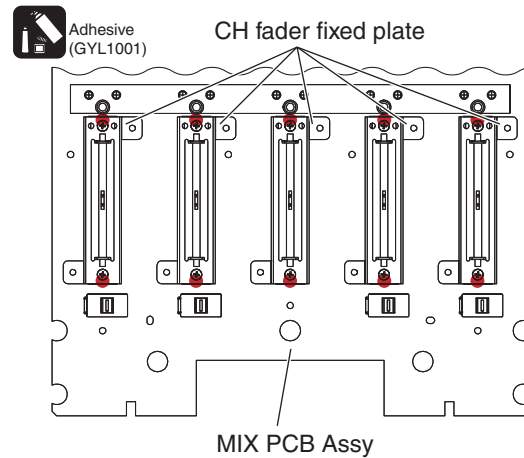

• Bottom view

8. EACH SETTING AND ADJUSTMENT

8.1 NECESSARY ITEMS TO BE NOTED

After repairing, be sure to check the version of the firmware, and if it is not the latest one, update to the latest version. Perform the each item when the following parts are replaced.

- IC storing firmware and PCB Assy
IC24, IC25 (DSP PCB Assy),
DSP PCB Assy → • Confirmation of the version of the firmware
• Updating to the latest version of the firmware
- When replaced WHEEL Assy → • Confirmation of the specified value by the mode which
measures rotary decline time of the jog dial

8.2 UPDATING OF THE FIRMWARE

What you need for updating

- Update file for DDJ-SX
* When the downloaded zip file is double-clicked, the update file is unzipped.
Example) DDJ-SX_V101.jar



- A computer where Java has been installed.
* If Java has not been installed, please download the Java Runtime Environment (JRE)
at: <http://java.com> and install it on your computer.

Updating procedures

- ① Connect the above prepared computer to DDJ-SX via the USB cable included with the product.



- ③ When the update file for DDJ-SX (DDJ-SX_Vxxx.jar) is activated, the following dialogue is displayed. Click the [Start] button.

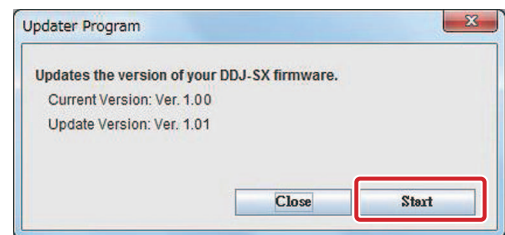

- ② Turn on the power of DDJ-SX while pressing the [SHIFT] button and the [SYNC] button on the LEFT deck ensure the Level meter LEDs flash before releasing your finger from the these buttons.

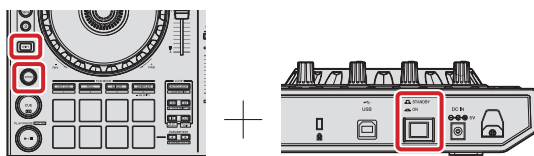

- ④ The update of the firmware starts.

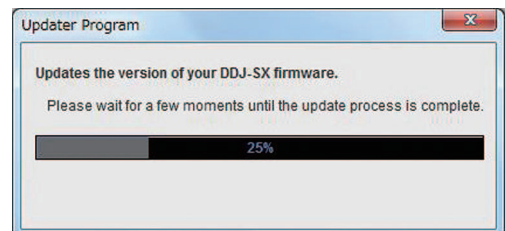

DDJ-SX

A ⑤ When the firmware update process is complete, click the [OK] button.

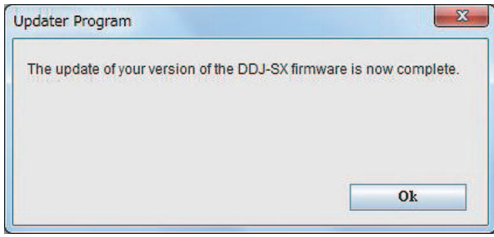

B Please note that if you fail to update, turn on the power of DDJ-SX again and start from Step ③ of the above Updating Procedures.

How to check the firmware version

[For Windows]

ASIO driver exclusively for DDJ-SX is required to be installed.

From the [Start menu],
Run [All the programs] → [Pioneer] → [DDJ-SX] → [DDJ_SX Version Display Utility]



Pioneer_DDJ_SX_Versio
n.exe

C

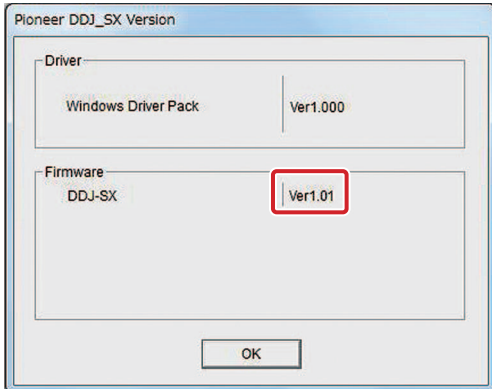

D

[For Mac]

Open the Apple menu while pressing the option key, then select "System Profiler."



E

Select the [USB] from the [Hardware] to display the name of the controller. Select the controller to display the firmware version.

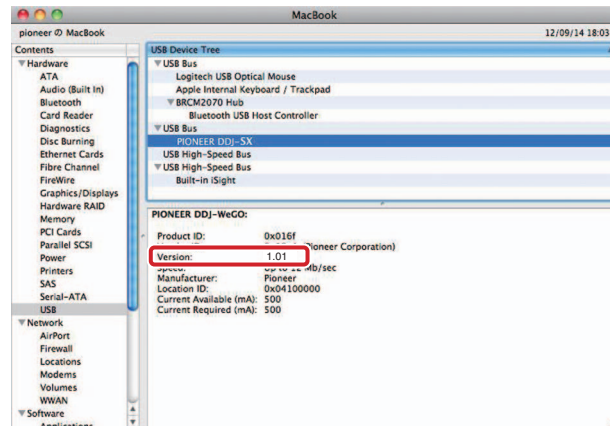

F

8.3 ITEMS FOR WHICH USER SETTINGS ARE AVAILABLE

This unit is provided with user settable items, as shown below.

Item for Which User's Setting is Available	Setting Value (The factory default settings are indicated in bold.) / Indication method	Part Name	Content to be Stored
Settings for DJ software other than Serato DJ	Serato DJ: / [KEY LOCK] unlit Software other than Serato DJ: / [KEY LOCK] lit	IC24 (DSP PCB Assy)	UTILITY setting Setting value
Channel fader start setting	Channel fader start with sync: /Left Effect Parameter button lit on the left deck Channel fader start without sync: /Center Effect Parameter button lit on the left deck Channel fader start function disabled: /Right Effect Parameter button lit on the left deck		
Change of the Master Attenuator setting	0 dB (without attenuation): / [HOT CUE] mode button lit -3 dB: / [ROLL] mode button lit -6 dB: / [SLICER] mode button lit		
Setting for flashing in Slip mode	Flashing in Slip mode enabled: / [SLIP] button lit Flashing in Slip mode disabled: / [SLIP] button unlit		
Demo mode setting	Demo mode enabled: / [TAP] button lit Demo mode disabled: / [TAP] button unlit		
Velocity curve setting for SAMPLER VELOCITY mode	Curve 1 (Linear): / [LOOP 1/2X] button lit Curve 2: / [LOOP 2X] button lit Curve 3: / [LOOP IN] button lit Curve 4 (3 steps): / [LOOP OUT] button lit		
MIDI setting for SAMPLER VELOCITY mode	3 ms: /Number of LEDs of the level indicator lit: 0 4 ms: /Number of LEDs of the level indicator lit: 1 } } 13 ms: /Number of LEDs of the level indicator lit: 10		
Illumination mode setting for the jog dial	Pattern 1 without dimmer: /Only the PAD1 LED lit Pattern 2 without dimmer: /Only the PAD2 LED lit Reverse pattern 1 without dimmer: /Only the PAD3 LED lit Reverse pattern 2 without dimmer: /Only the PAD4 LED lit Pattern with dimmer: /Only the PAD5 LED lit		

Each of the above items can be set in Utility mode.

To enter Utility mode, while holding the SHIFT and PLAY/PAUSE ►/|| buttons on the left deck pressed, turn the unit ON. During Utility mode, the PLAY/PAUSE LEDs on both decks are lit.

After Utility mode is entered, the current setting for each item is indicated with the corresponding LED.

(For details, refer to the operating instructions.)

9. EXPLODED VIEWS AND PARTS LIST

NOTES: ● Parts marked by "NSP" are generally unavailable because they are not in our Master Spare Parts List.

● The \triangle mark found on some component parts indicates the importance of the safety factor of the part. Therefore, when replacing, be sure to use parts of identical design.

● Screws adjacent to ∇ mark on product are used for disassembly.

● For the applying amount of lubricants or glue, follow the instructions in this manual.

(In the case of no amount instructions, apply as you think it appropriate.)

9.1 PACKING SECTION

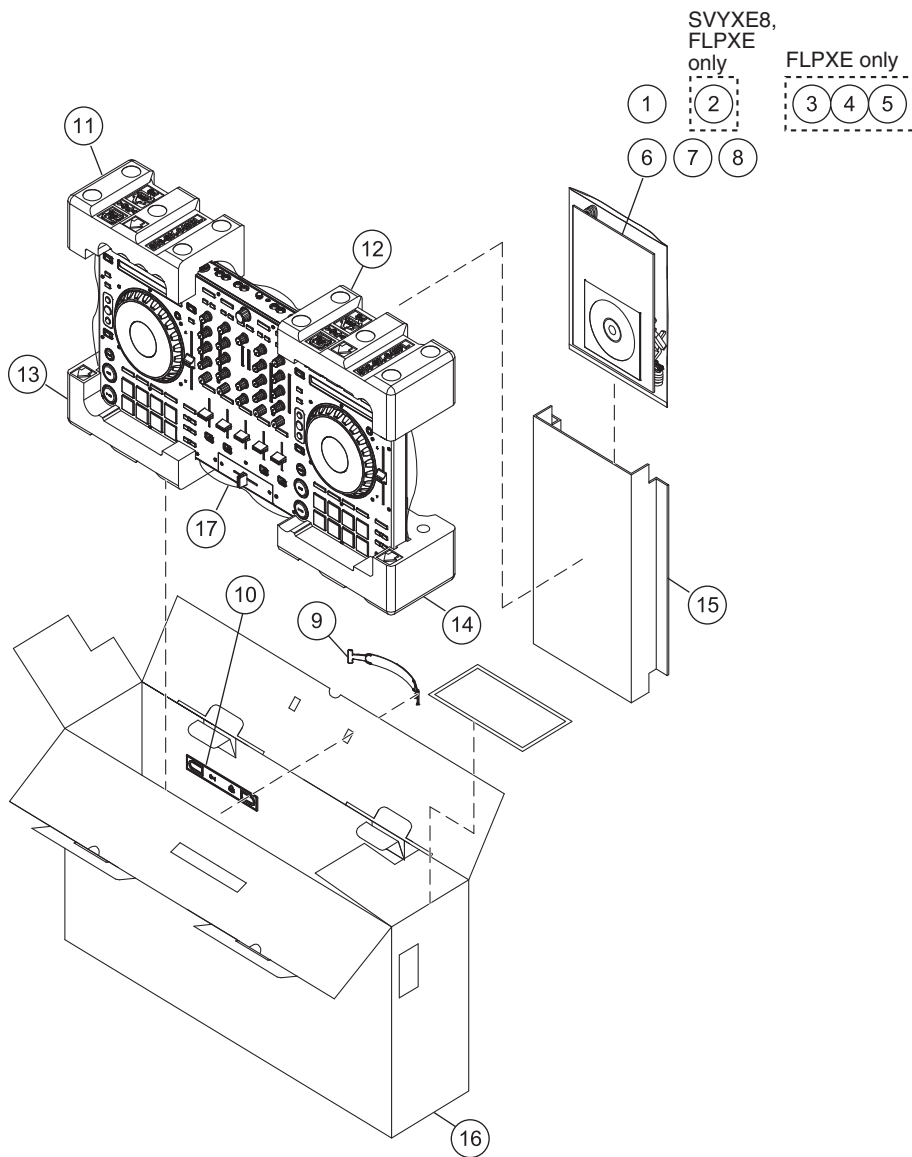

(1) PACKING SECTION PARTS LIST

Mark No.	Description	Part No.
⚠	1 AC Adapter	See Contrast table (2)
⚠	2 Power Plug	See Contrast table (2)
⚠	3 Power Plug	See Contrast table (2)
⚠	4 Power Plug	See Contrast table (2)
⚠	5 Power Plug	See Contrast table (2)
	6 USB Cable	408-100UG-087-HA
	7 CD-ROM (Installation Disc)	429-S1-142-HA
	8 Read Before Use (Important)/ Quick Start Guide	See Contrast table (2)
	9 Handle	100-DDJLE-3012-HA
	10 Handle Base	100-DDJLE-3013-HA
	11 Polyfoam BL	506-SX-648BL-HA
	12 Polyfoam BR	506-SX-648BR-HA
	13 Polyfoam FL	506-SX-648FL-HA
	14 Polyfoam FR	506-SX-648FR-HA
	15 Paster board	507-S1-3372-HA
	16 Gift Box	See Contrast table (2)
	17 Soft Bag	509-DDJSX-320-HA

(2) CONTRAST TABLE

DDJ-SX/UXECB, SVYXE8, FLPXE, AXE5 and KXE5 are constructed the same except for the following:

Mark	No.	Symbol and Description	DDJ-SX /UXECB	DDJ-SX /SVYXE8	DDJ-SX /FLPXE	DDJ-SX /AXE5	DDJ-SX /KXE5
⚠	1	AC Adapter	411-S1-878-HA	411-S1-879-HA	411-S1-880-HA	411-S1-881-HA	411-S1-882-HA
⚠	2	Power Plug	Not used	420-DJM250-362-HA	420-DJM250-364-HA	Not used	Not used
⚠	3	Power Plug	Not used	Not used	420-DJM250-363-HA	Not used	Not used
⚠	4	Power Plug	Not used	Not used	420-DJM250-362-HA	Not used	Not used
⚠	5	Power Plug	Not used	Not used	420-DJM250-361-HA	Not used	Not used
	8	Read Before Use (Important)/ Quick Start Guide (En)	502-DDSXA-3277-HA	Not used	Not used	Not used	Not used
	8	Read Before Use (Important)/ Quick Start Guide (En, Fr, De, It, Es, Po, Py)	Not used	502-DDSXB-3278-HA	Not used	Not used	Not used
	8	Read Before Use (Important)/ Quick Start Guide (En)	Not used	Not used	502-DDSXF-3282-HA	Not used	Not used
	8	Read Before Use (Important)/ Quick Start Guide (Zhcn)	Not used	Not used	Not used	502-DDSXD-3280-HA	Not used
	8	Read Before Use (Important)/ Quick Start Guide (Ko)	Not used	Not used	Not used	Not used	502-DDSXE-3281-HA
	16	Gift Box	507-S1-3370A-HA	507-SXB-3370A-HA	507-SXF-3370A-HA	507-SXD-3370-HA	507-SXE-3370-HA

9.2 EXTERIOR SECTION

1

2

3

4

A

B

C

D

E

F

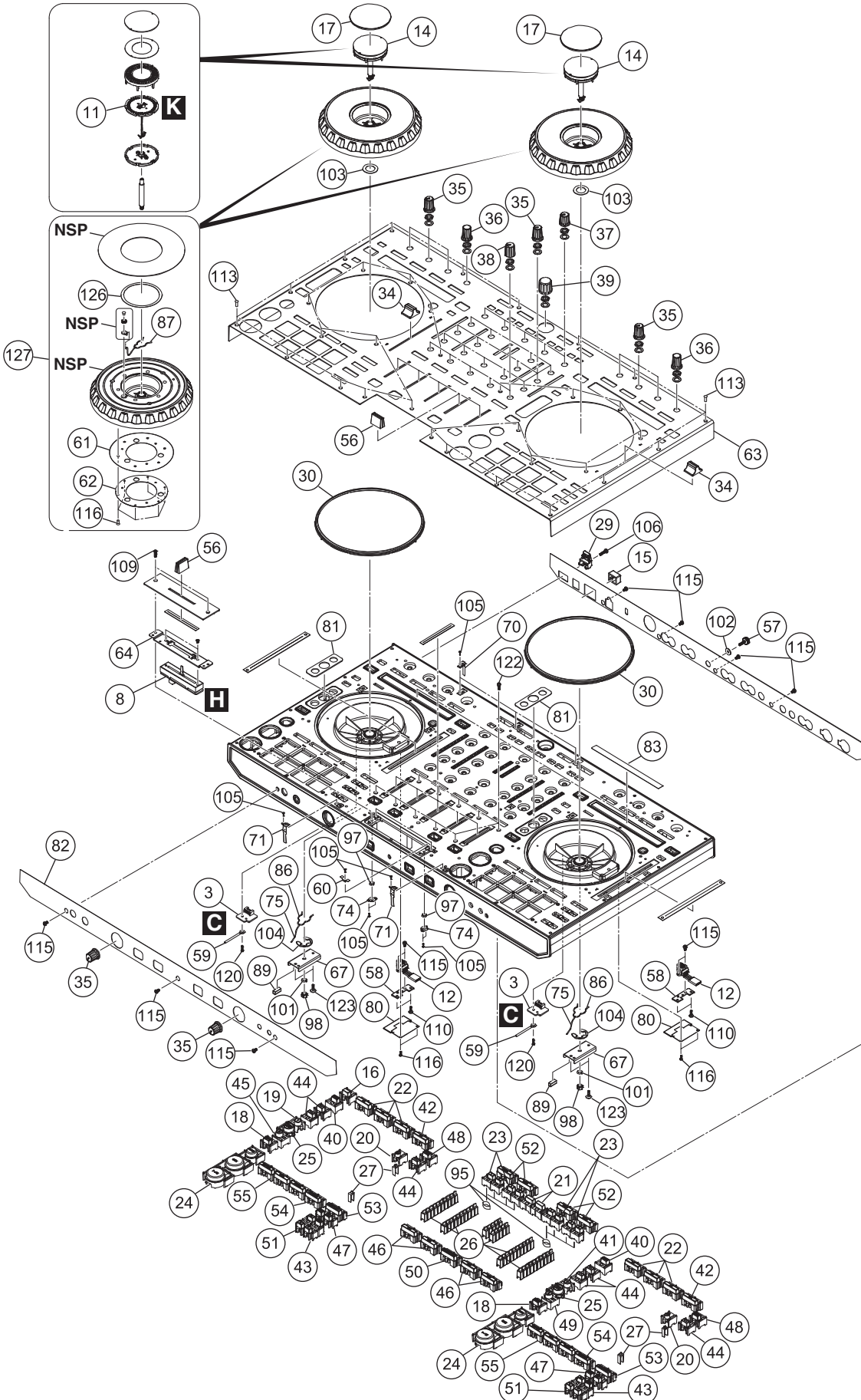

DDJ-SX

1

2

3

4

EXTERIOR SECTION PARTS LIST

	<u>Mark No.</u>	<u>Description</u>	<u>Part No.</u>	<u>Mark No.</u>	<u>Description</u>	<u>Part No.</u>
A	1	CONTROL PCB Assy A	704-DDJS1-A421-HA	46	CUE Button	100-S1B-2993-HA
	2	CONTROL PCB Assy B	704-DDJS1-A454-HA	47	2X Button	100-S1B-2994-HA
	3	TRANSFER PCB Assy	704-DDJS1-A429-HA	48	VINYL Button	100-S1C-2989-HA
	4	DSP PCB Assy	704-DDJS1-A418-HA	49	DECK 4 Button	100-S1C-2990-HA
	5	OUTPUT PCB Assy	704-DDJS1-A425-HA	50	MASTER CUE Button	100-S1C-2993-HA
	6	BAL. PCB Assy	704-DDJS1-A423-HA	51	Button	100-S1C-2994-HA
	7	MIX PCB Assy	704-DDJS1-A417-HA	52	LOAD Button	100-S1D-2993-HA
	8	CH FADER PCB Assy	704-DJM250-A032-HA	53	AUTO LOOP Button	100-S1E-2993-HA
	9	FRONT PCB Assy	704-DDJS1-A424-HA	54	S.S Button	100-S1F-2993-HA
	10	TOUCH PCB Assy	704-DDJS1-A426-HA	55	H.R Button	100-S1G-2993-HA
B	11	LED PCB Assy	704-DDJS1-A422-HA	56	Push Button	100-22-2824-HA
	12	SENSOR PCB Assy	704-PDJ33-A007-HA	57	Ground Terminal	200-S1-665-HA
	13	PAD & FSR Assy	704-S1-A458-HA	58	Sensor Fixed Plate	300-HDJ9800-981-HA
	14	LED & COVER Assy	704-DDJS1-A455-HA	59	Winding Fixture	300-HM510B-224-HA
	15	Power Knob	100-HDJ2000-1641-HA	60	Ground Plate	300-MX200-1743-HA
	16	Rectangular Button	100-SX-2989S-HA	61	Encoder Plate	300-PROS2-848-HA
	17	Windows Lens	100-S1-2985-HA	62	Encoder Fixed Plate	300-PROS2-851-HA
	18	SHIFT Button	100-S1-2989-HA	63	Front Panel	300-S1-2043-HA
	19	DECK 1 Button	100-S1-2990-HA	64	CF Fixed Plate	300-S1-2045-HA
	20	LITTLE ROUND Button	100-S1-2991-HA	65	CH Fader Fixed Plate	300-S1-2046-HA
C	21	2 Key Button	100-S1-2992S-HA	66	XLR Fixed Plate	300-S1-2048-HA
	22	ON Button	100-S1-2993-HA	67	JW LED Base	300-S1-2049-HA
	23	1,2 Button	100-S1-2994-HA	68	••••	
	24	PLAY SYNC Button	100-S1-2995-HA	69	Ground Plate	300-S1-2051-HA
	25	DUAL DECK Button	100-S1-2996-HA	70	Ground Plate	300-S1-2057-HA
	26	LM Lens	100-S1-2997-HA	71	Ground Plate	300-S1-2058-HA
	27	Tempo Lens	100-S1-2998-HA	72	Cover	300-S1-2059-HA
	28	Fixed Plate	100-S1-2999-HA	73	Isolation Plate	300-S1-2060-HA
	29	Strain Relief Bush	100-S1-3000-HA	74	Fixed Cover	300-33-1918-HA
	30	JW Ring	100-S1-3001-HA	75	1P Lead Wire	406-S1-1231-HA
	31	VR Cover	100-S1-3002-HA	76	••••	
	32	CF Button	100-S1-3003-HA	77	30P 1.0 FFC Cable	406-S1-1233-HA
	33	Button	100-S1-3004-HA	78	37P 1.0 FFC Cable	406-S1-1234-HA
	34	SPEED PUSH Button	100-S1-3005-HA	79	37P 1.0 FFC Cable	406-S1-1235-HA
	35	FX Rotate Knob	100-S1-3006-HA	80	Dust-Proof Slice	501-HDJ9800-1648-HA
	36	Beat Rotate Knob	100-S1-3007-HA	81	Deck Panel	501-S1-2521-HA
	37	Gain Rotate Knob	100-S1-3008-HA	82	Front Panel	501-S1-2522-HA
	38	Filter Rotate Knob	100-S1-3009-HA	83	Search Panel	501-S1-2524-HA
	39	Browser Rotate Knob	100-S1-3010-HA	84	Isolation Slice	501-S1-2542-HA
	40	CENSOR Button	100-S1A-2989-HA	85	••••	
	41	DECK 2 Button	100-S1A-2990-HA	86	Clip (1mm)	603-S1-394-HA
	42	TAP Button	100-S1A-2993-HA	87	Clip	603-S1-395-HA
	43	IN/OUT Button	100-S1A-2994-HA	88	Velocity Soft Knob	604-S1-608-HA
	44	CENSOR Button (-)	100-S1B-2989-HA	89	Sponge	612-DJFA-373-HA
	45	DECK 3 Button	100-S1B-2990-HA	90	Foot Mat	612-S1-445-HA

F

<u>Mark No.</u>	<u>Description</u>	<u>Part No.</u>	
91	Cushion	612-S1-449-HA	
92	Cushion	612-S1-450-HA	
93	Sponge (8*6*18mm)	612-S1-451-HA	A
94	Cushion	612-S1-459-HA	
95	Shade Cover	505-S1-243-HA	
96	Sponge	612-F300-358-HA	
97	Nut (M3*P0.5,CD,PB,HH)	601-A100-004-HA	
98	Nut (M5,7.9*3.8MM)	601-MM1000-029-HA	
99	Nut BLK+Gear Washer	601-R2150-033-HA	
100	Washer	606-KMD280-081-HA	
101	Washer	606-DDJLE-260-HA	
102	Washer (10*3.2*1T)	606-S1-007-HA	B
103	Washer	606-S1-261-HA	
104	E Type Washer	606-S1-262-HA	
105	Screw (TTB,2*5,MC)	602-A700-494-HA	
106	Screw	602-BTB3012-446B-HA	
107	Screw (SAE1018PTP3*8)	602-B600-057-HA	
108	Screw	602-B600-072-HA	
109	Screw (CTF,M3*10)	602-CTF3010-698B-HA	
110	Screw	602-DJ5500-452-HA	
111	Screw (M3*8)	602-HMD510B-198-HA	C
112	Screw (M2*P0.4*L6)	602-HP1010K-181-HA	
113	Screw	602-HP1010K-182-HA	
114	Screw	602-MK7-131-HA	
115	Screw	602-MP3-324-HA	
116	Screw	602-PROS2-363-HA	
117	Screw (TTP,3*L12)	602-PTP3012-571-HA	
118	Screw	602-QMX2BPM-322-HA	
119	Screw	602-SA12-414-HA	
120	Screw (2.6*8 TTP)	602-SL24F-099-HA	D
121	••••		
122	Screw (3*8MM TTB)	602-2002-077-HA	
123	Screw (3*10M/M)	602-3113-122-HA	
124	Sponge	612-S1-461-HA	
125	USB Fixed Plate	300-S1-2069-HA	
126	Twin Adhesive	501-S1-2526-HA	
127	Wheel Assy	704-S1-1383-HA	

E

F

10. SCHEMATIC DIAGRAM

10.1 CONTROL PCB ASSY A, B, and TRANSFER PCB ASSY

A CONTROL PCB ASSY A (704-DDJS1-A421-HA)

B CONTROL PCB ASSY B (704-DDJS1-A454-HA)

C TRANSFER PCB ASSY (704-DDJS1-A429-HA)

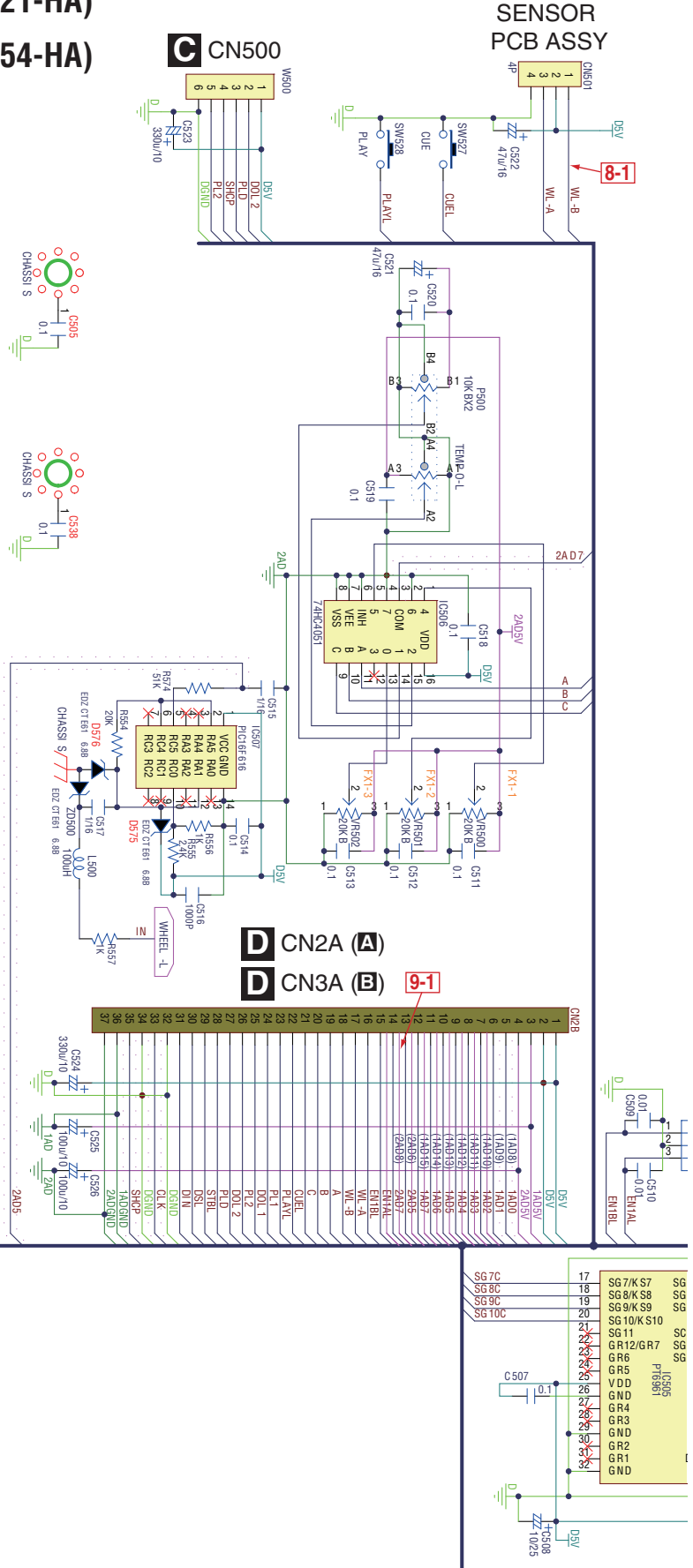
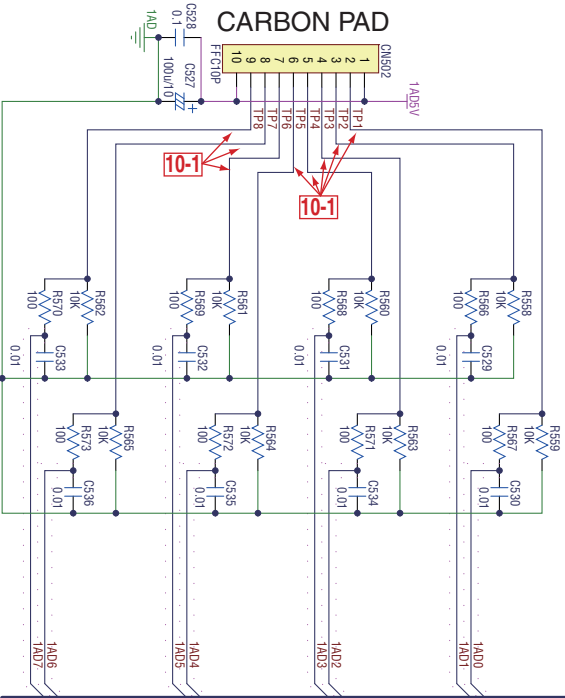
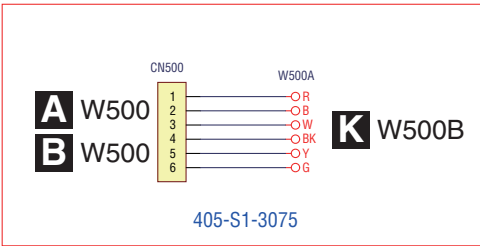

A B C

VSOR 3 ASSY

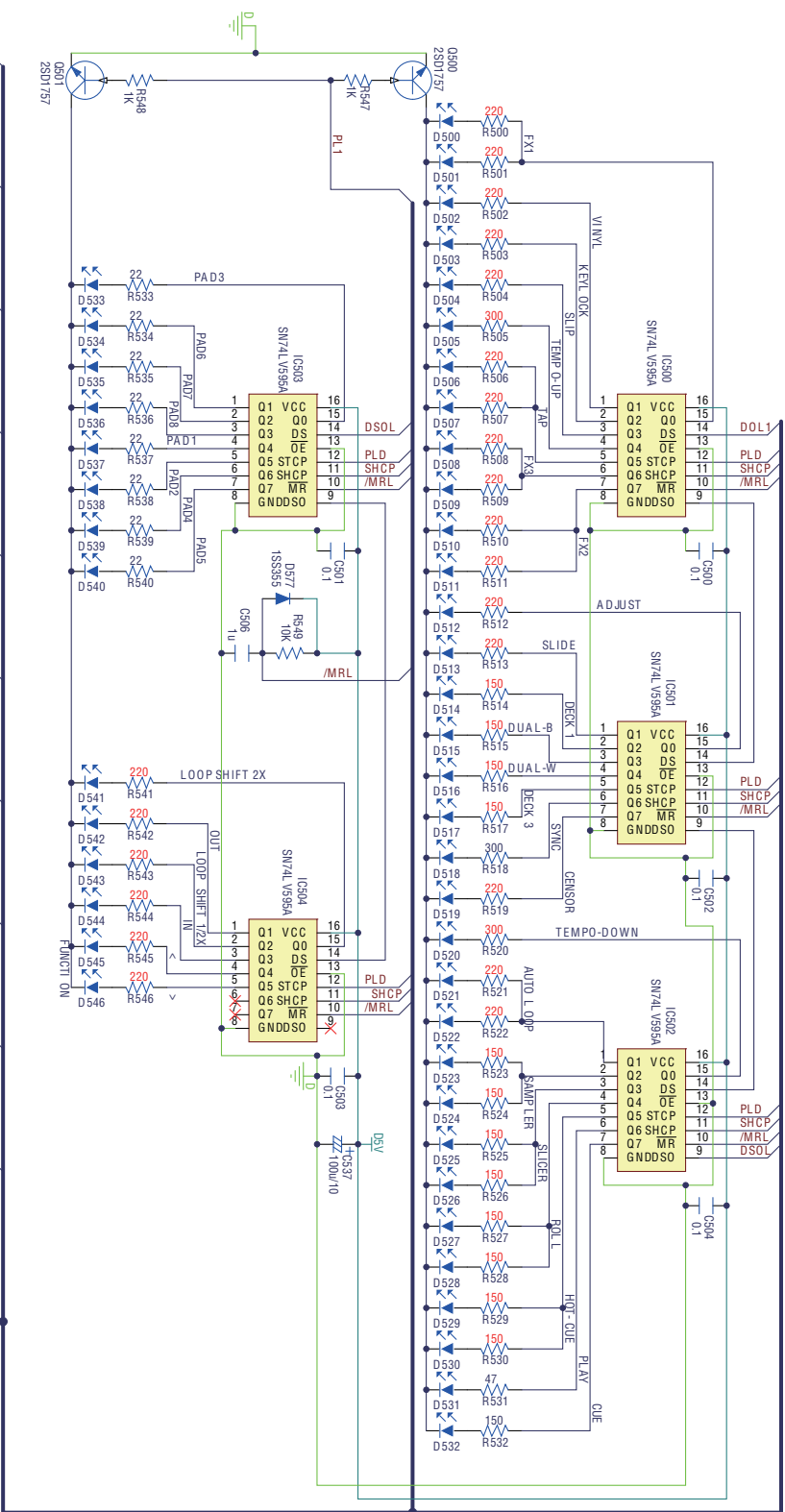
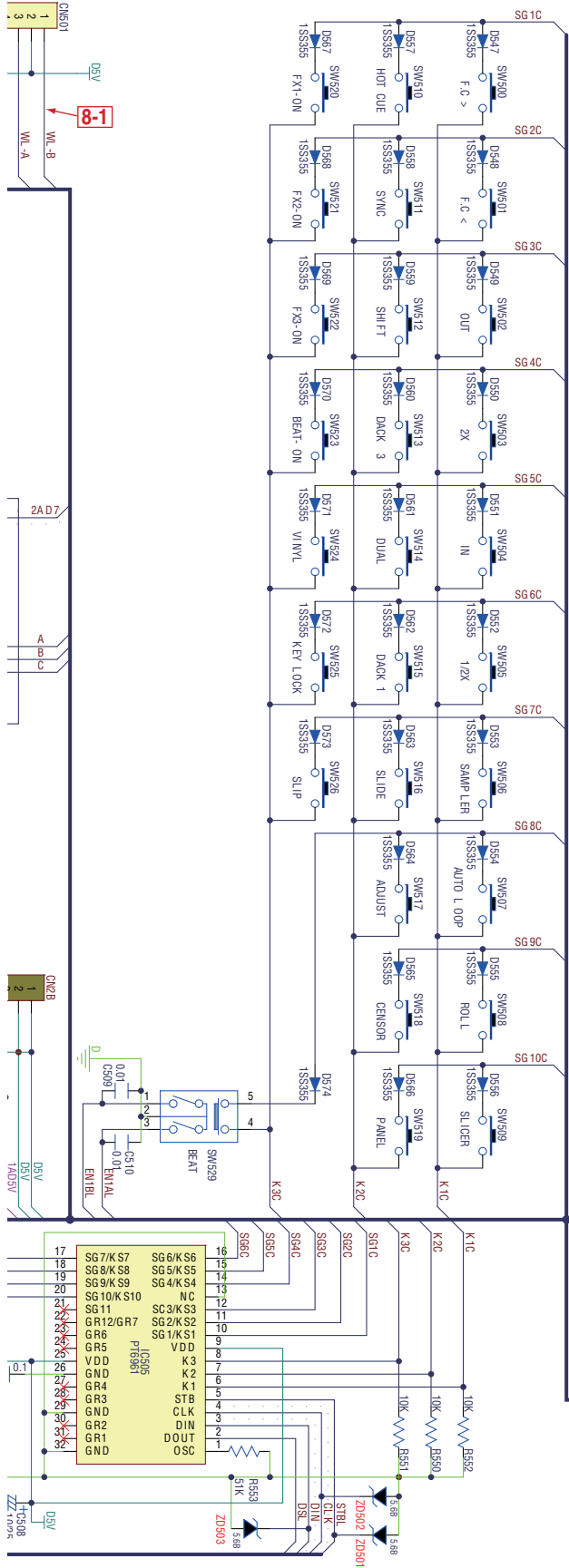

10.2 DSP, OUTPUT and BAL. PCB ASSYS

1

2

3

4

A

B

C

D

E

F

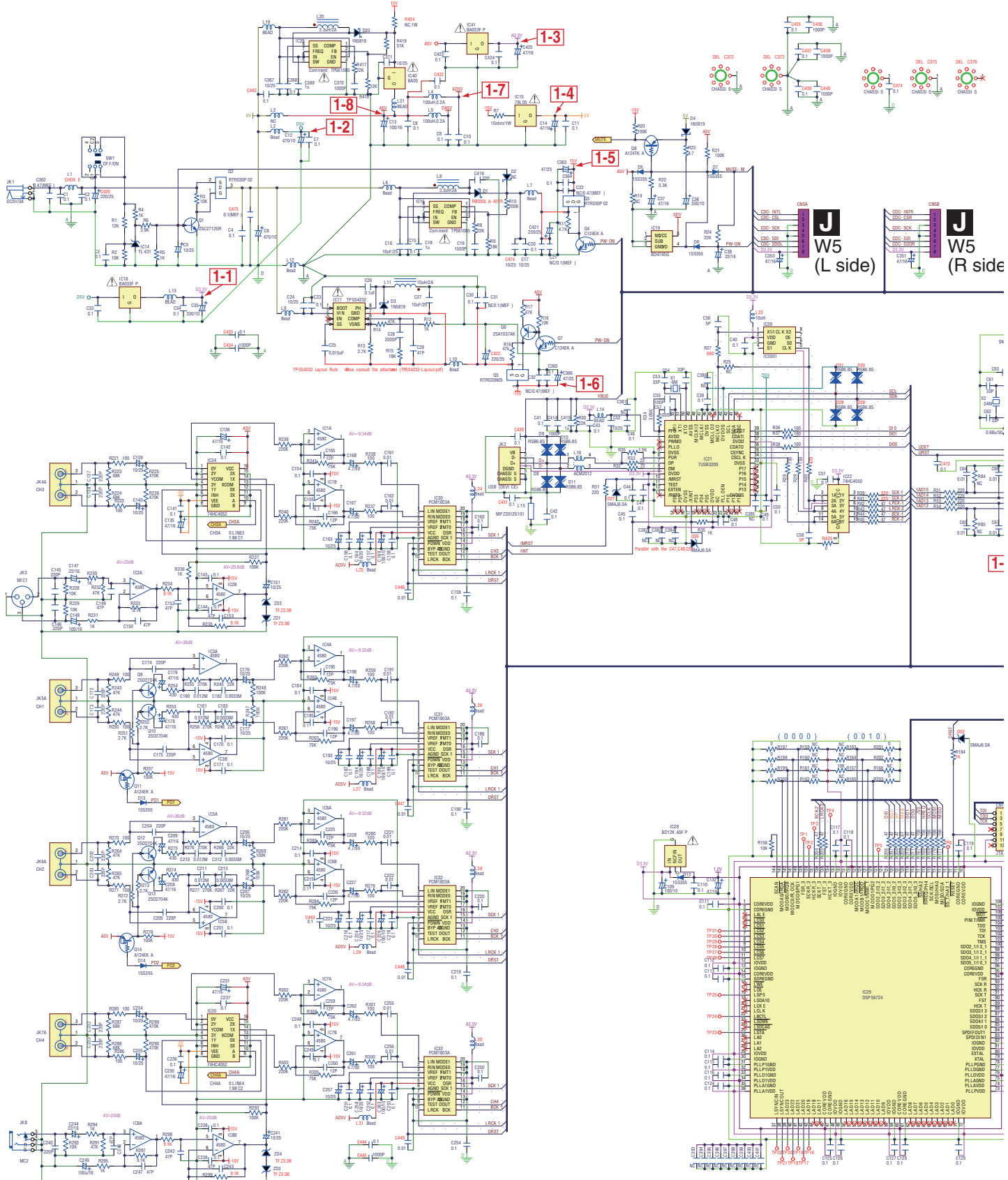

D

1

2

3

4

D DSP PCB ASSY (704-DDJS1-A418-HA)

A

B

C

D

E

F

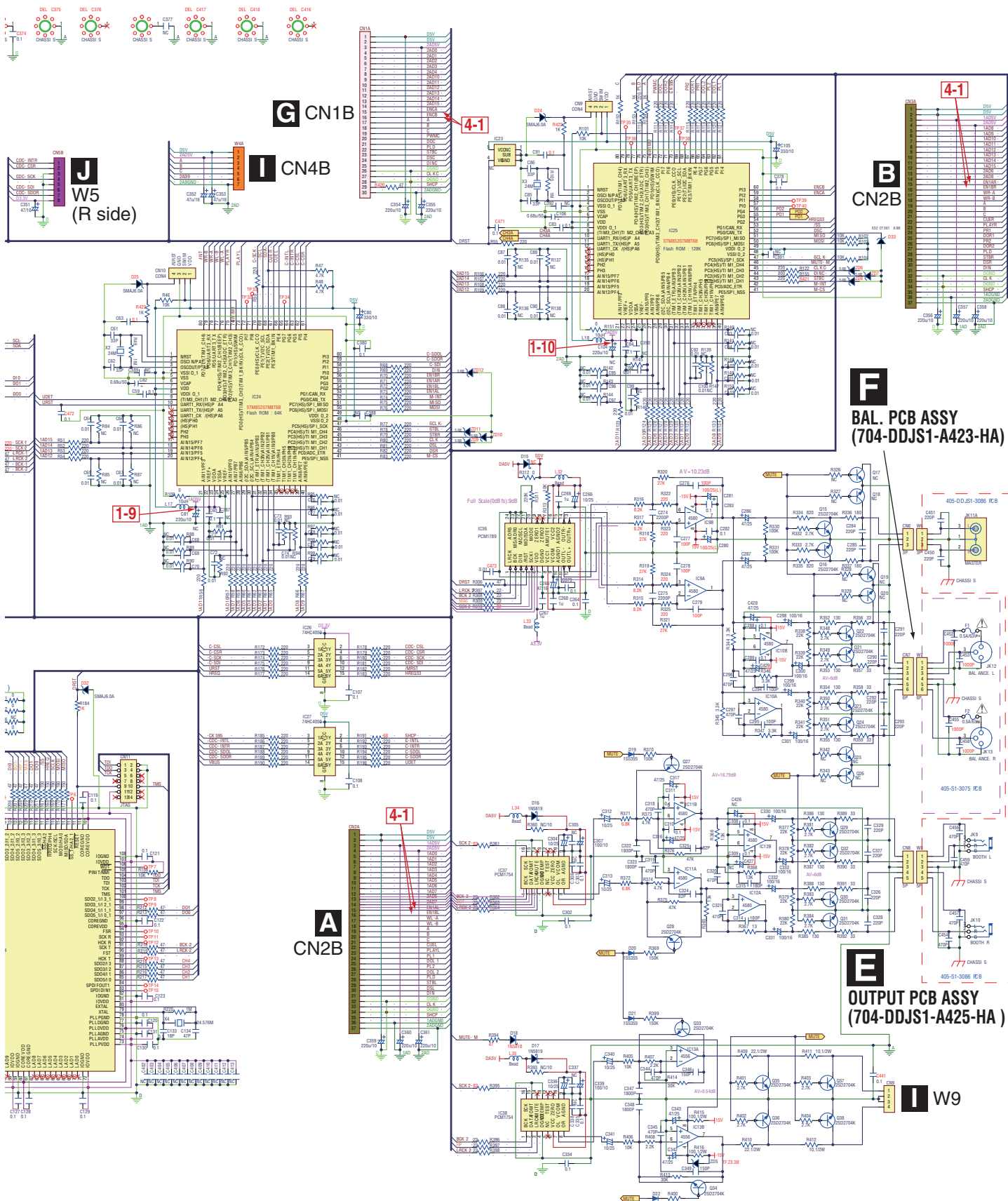

G CN1B

J W5 (R side)

I CN4B

B CN2B

F BAL. PCB ASSY (704-DDJS1-A423-HA)

A CN2A

E OUTPUT PCB ASSY (704-DDJS1-A425-HA)

W9



10.3 MIX and CH FADER PCB ASSYS

MIX PCB ASSY (704-DDJS1-A417-HA)

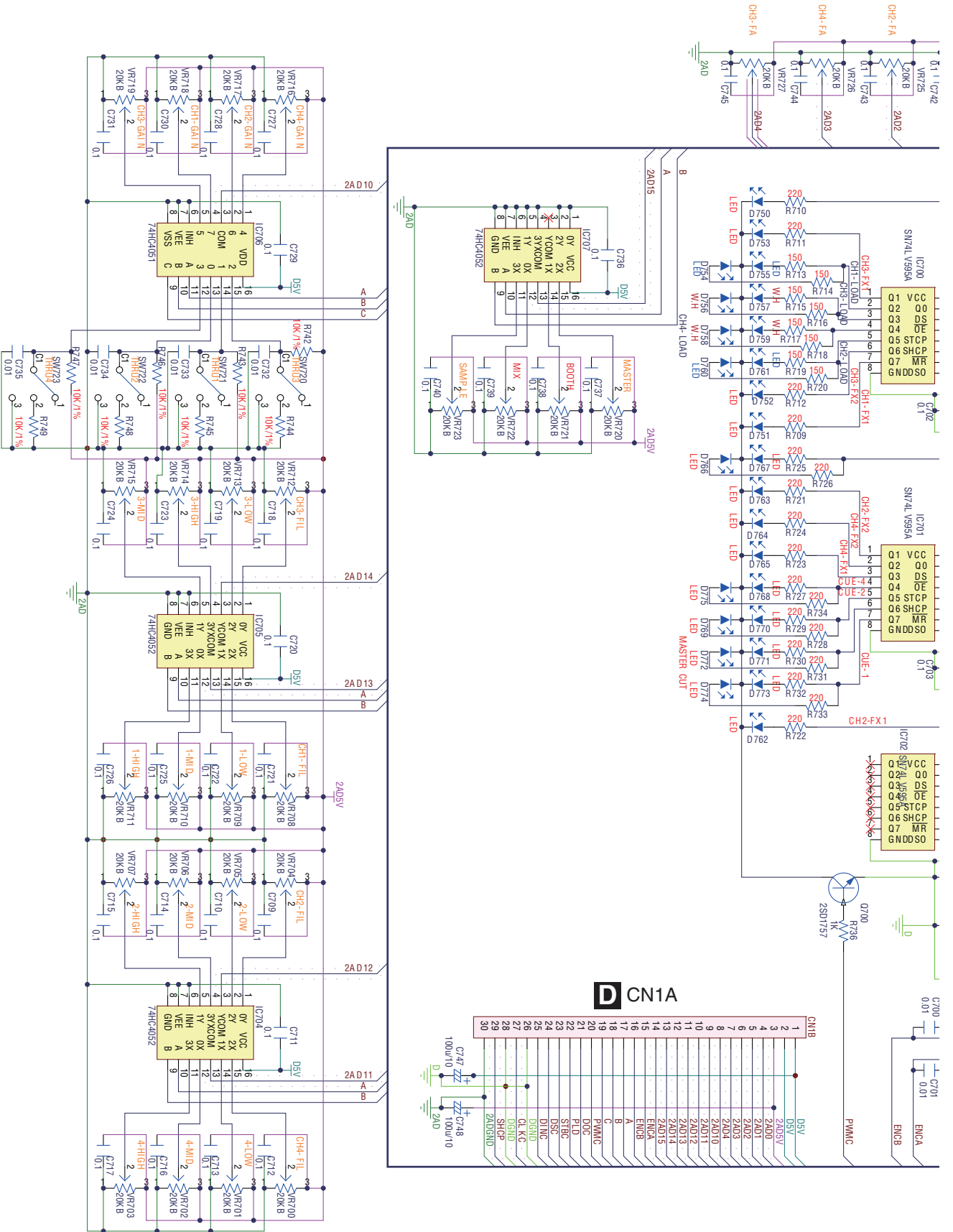

CH FADER PCB ASSY (704-DJM250-A032-HA)

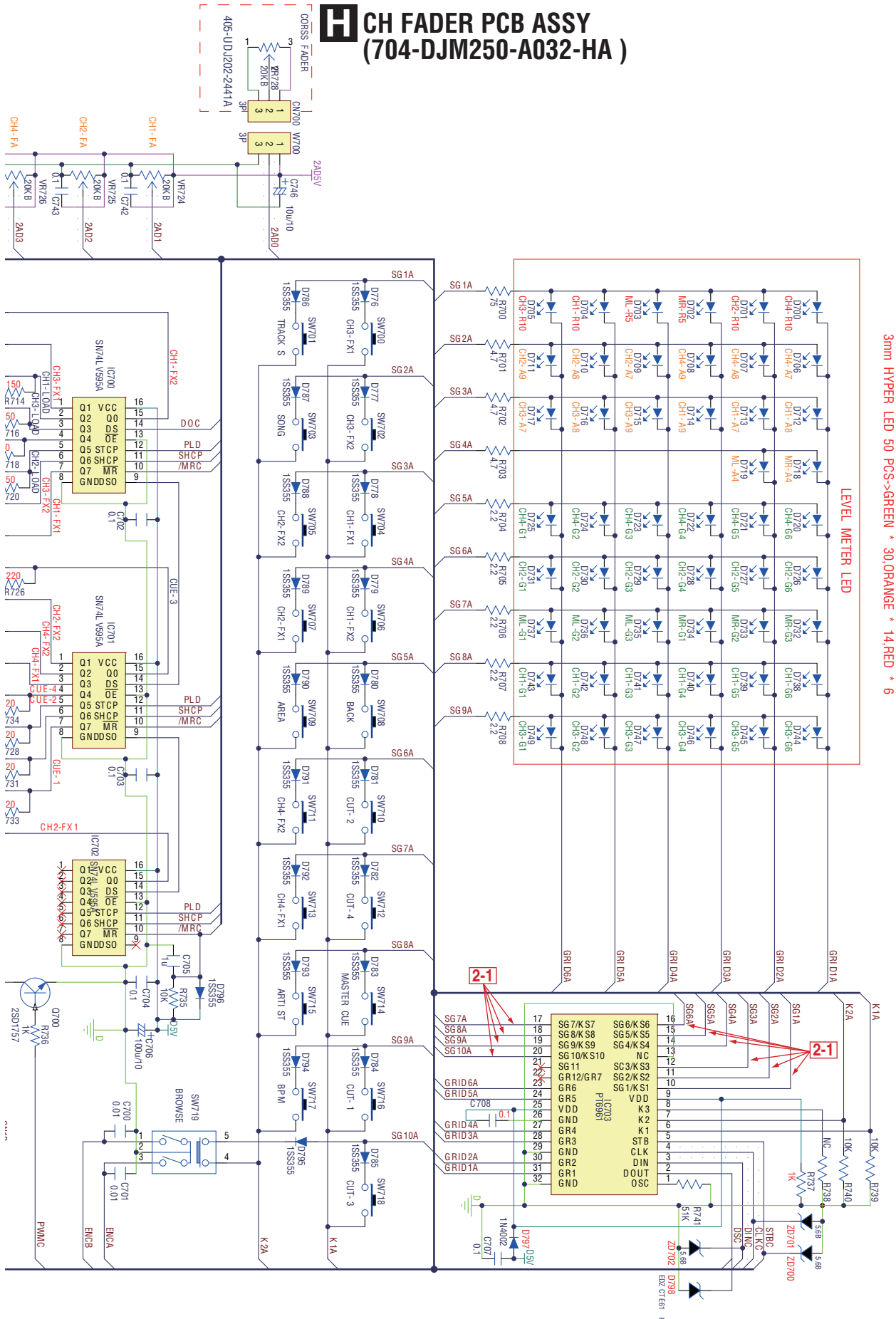

3mm HYPER LED 50 PCS->GREEN * 30,ORANGE * 14,RED * 6

LEVEL METER LED

10.4 FRONT PCB ASSY

FRONT PCB ASSY (704-DDJS1-A424-HA)

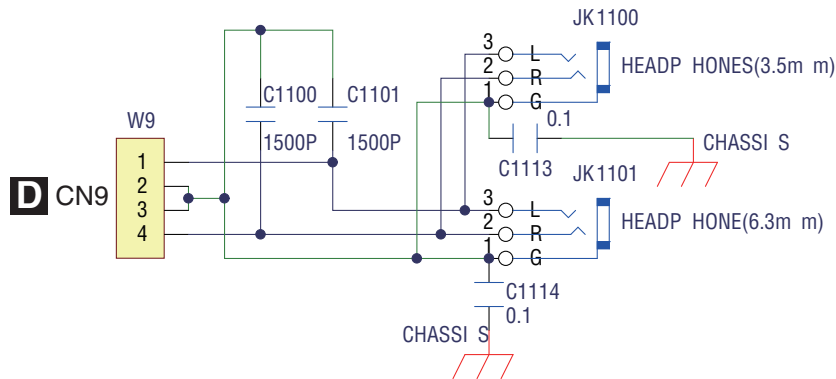
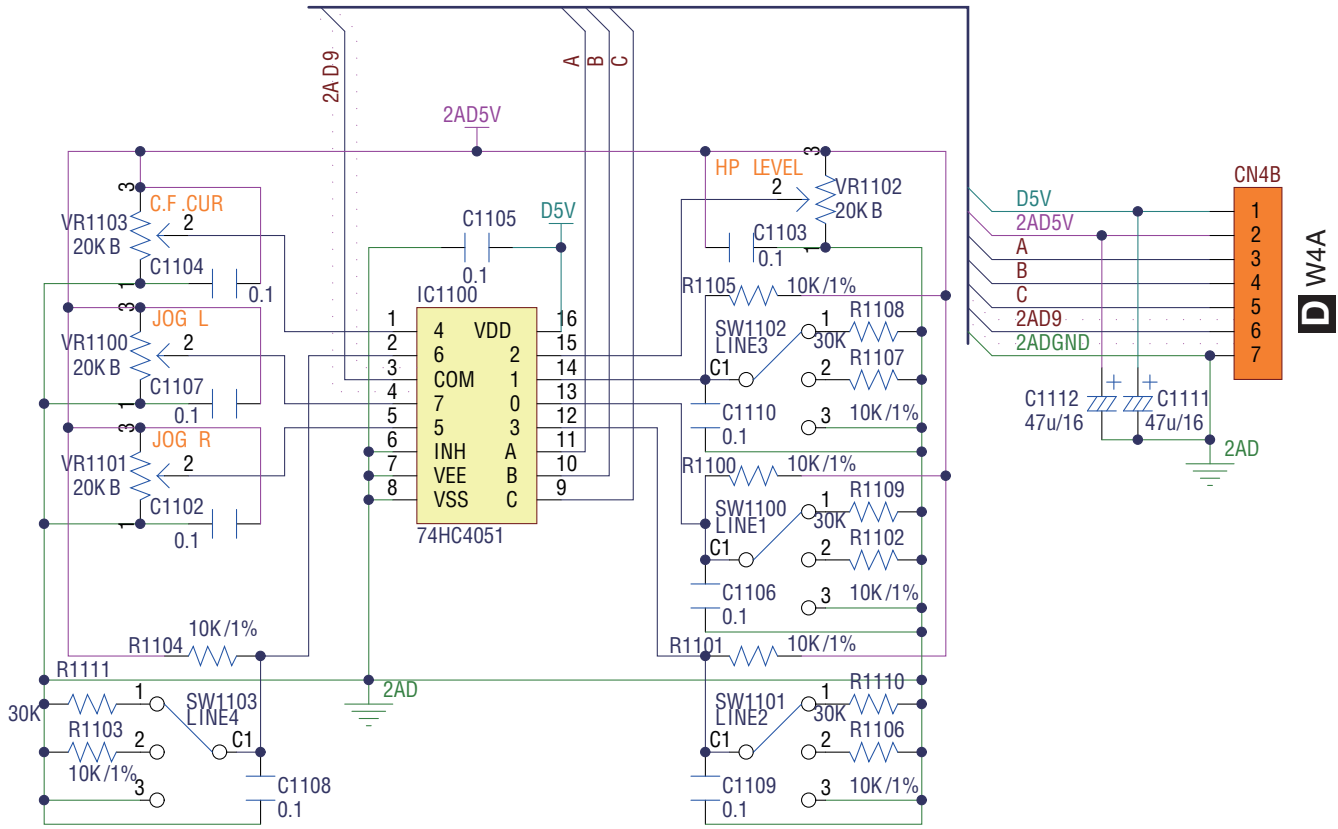

10.5 TOUCH PCB ASSY

J TOUCH PCB ASSY (704-DDJS1-A426-HA)

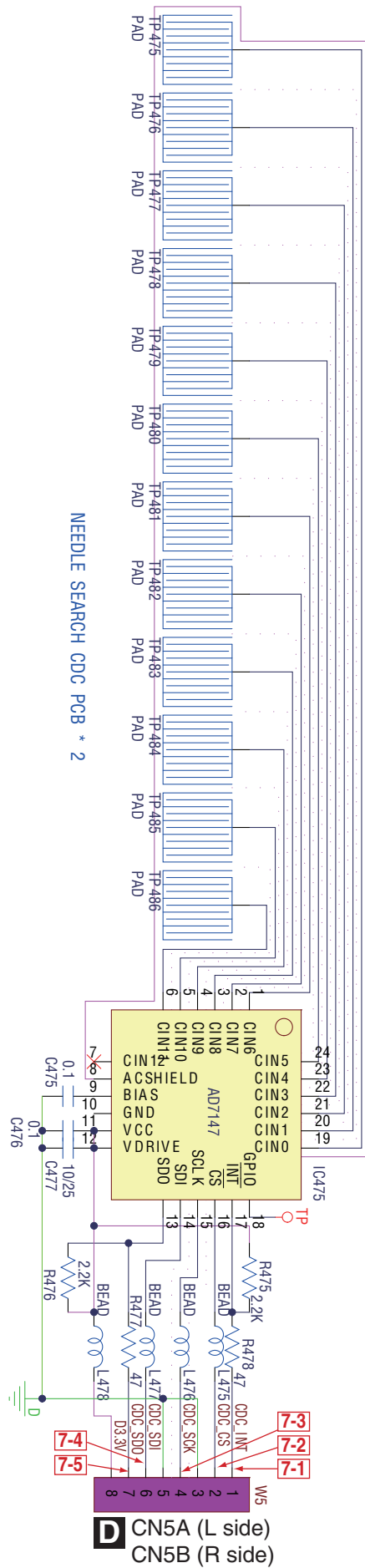

D CN5A (L side)
CN5B (R side)

DDJ-SX

A
B
C
D
E
F

J

10.6 LED PCB ASSY

K LED PCB ASSY (704-DDJS1-A422-HA)

C W500A

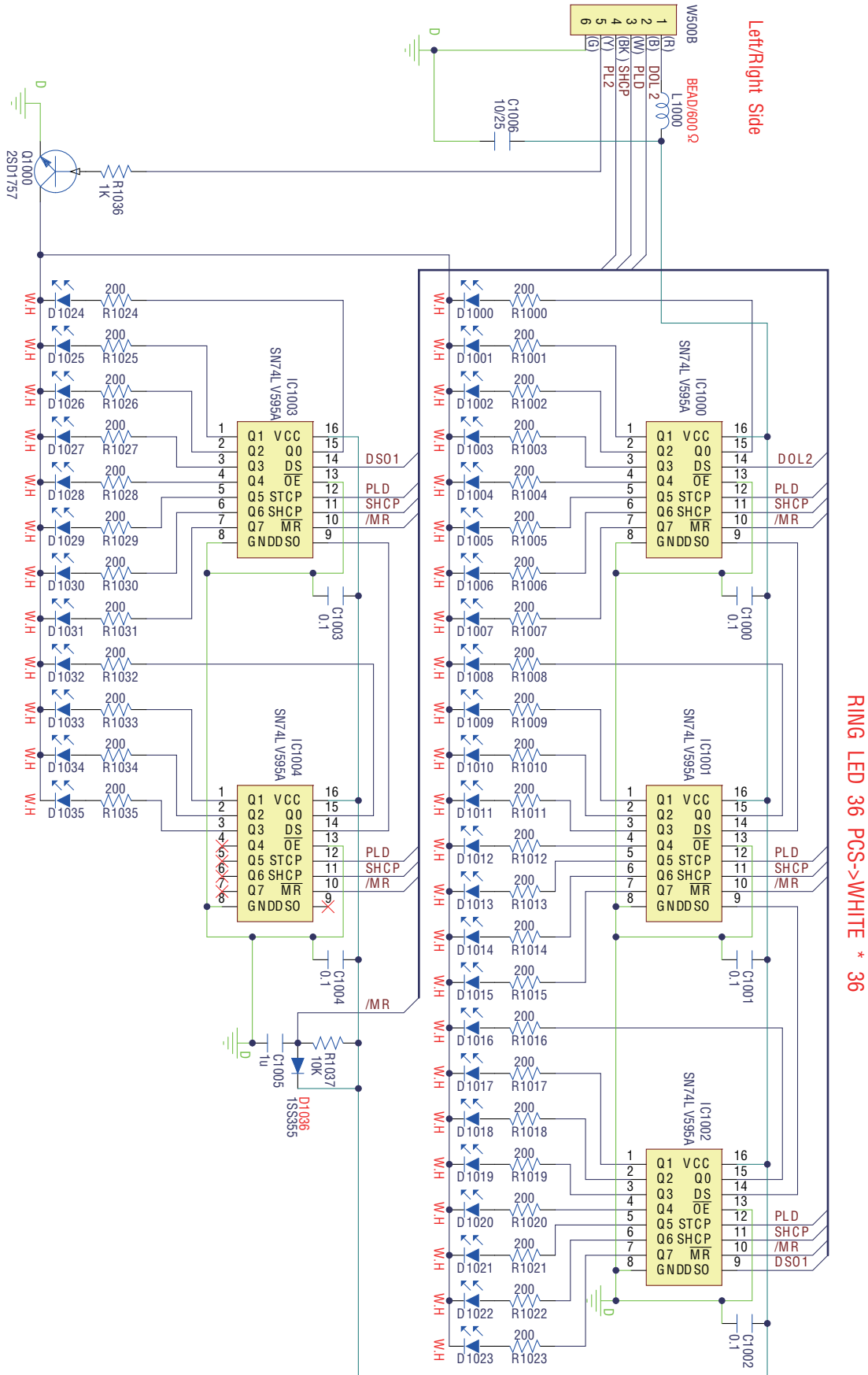

10.7 WAVEFORMS



A

8-1 WL-B (CN501 pin 1)

AD-DA SCK

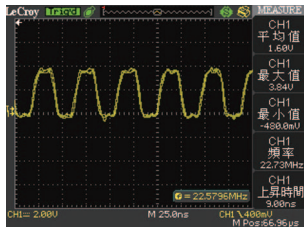
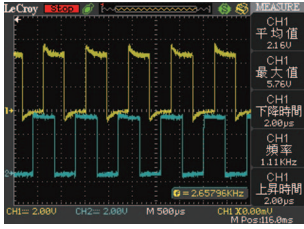

B

9-1 2AD7 (CN2B pin 13)

AD-DA BCK

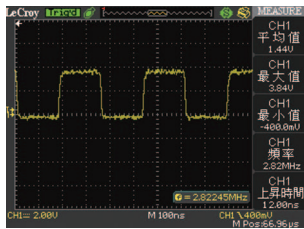
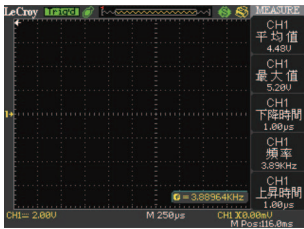

C

10-1 TP8 to TP2 (CN502 pins 2 to 9)

AD-DA LRCK

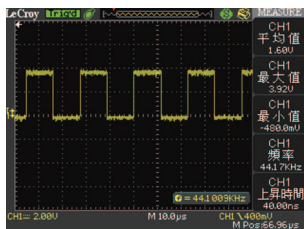
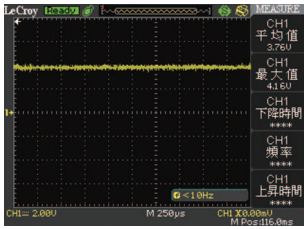

D

AD-DA DATA

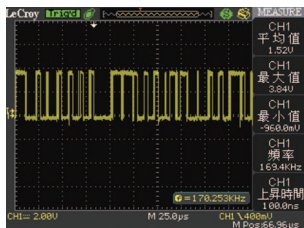

E

F

■

5

■

6

■

7

■

8

■

A

■

B

■

C

■

D

■

E

■

F

■

5

■

6

DDJ-SX

■

7

■

8

■

11. PCB CONNECTION DIAGRAM

11.1 CONTROLPCB ASSY A, B, and TRANSFER PCB ASSY

A SIDE A

A CONTROL PCB ASSY A

B CONTROL PCB ASSY B

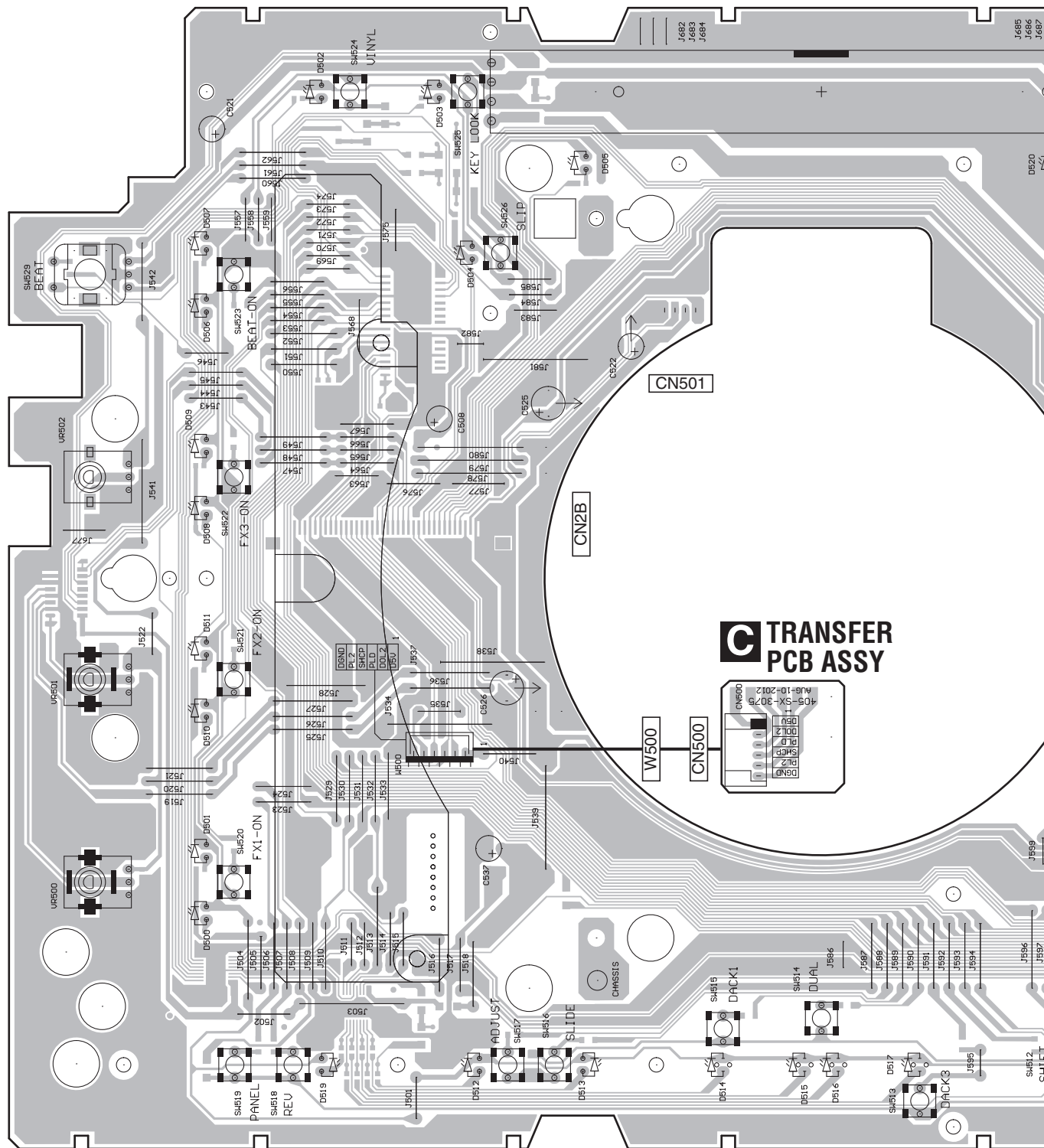

C TRANSFER PCB ASSY

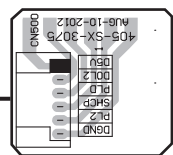

A B C

SIDE A

A

B

C

D

E

F

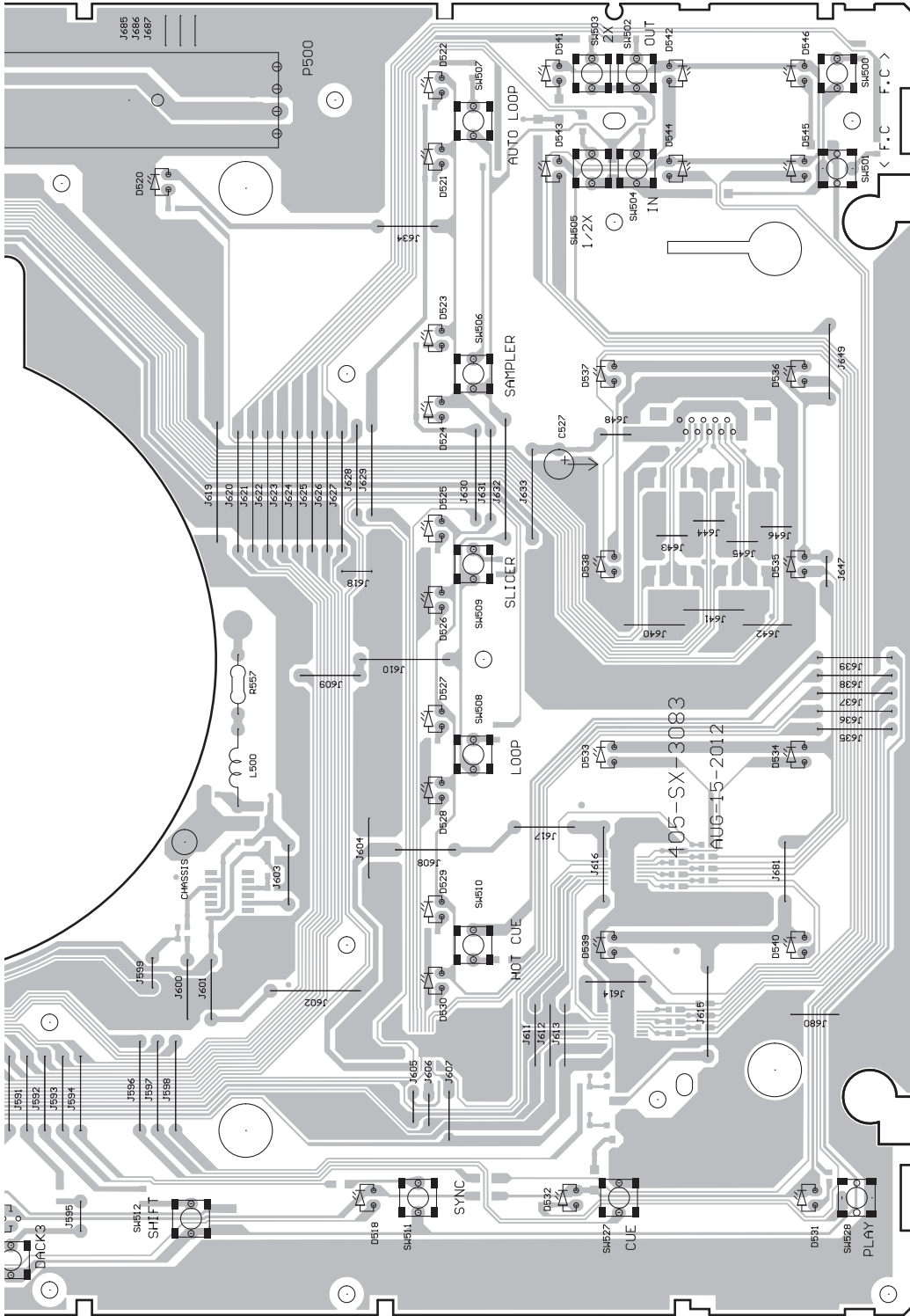

CN502

PCB 図に対する注意

1. この PCB 図にマウントしている部品は複数の仕向地の部品を含んでいます。各仕向地の情報は、回路図で確認するようにしてください。

2. PCB 図の見かた。

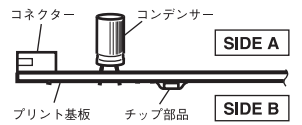

NOTE FOR PCB DIAGRAMS :

1. The parts mounted on this PCB include all necessary parts for several destinations. For further information for respective destinations, be sure to check with the schematic diagram.

2. View point of PCB diagrams.

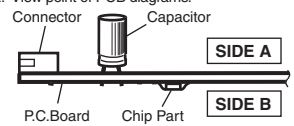

SIDE B

A

B

C

D

E

F

A CONTROL PCB ASSY A

B CONTROL PCB ASSY B

CARBON PAD ←

CN502

10-1

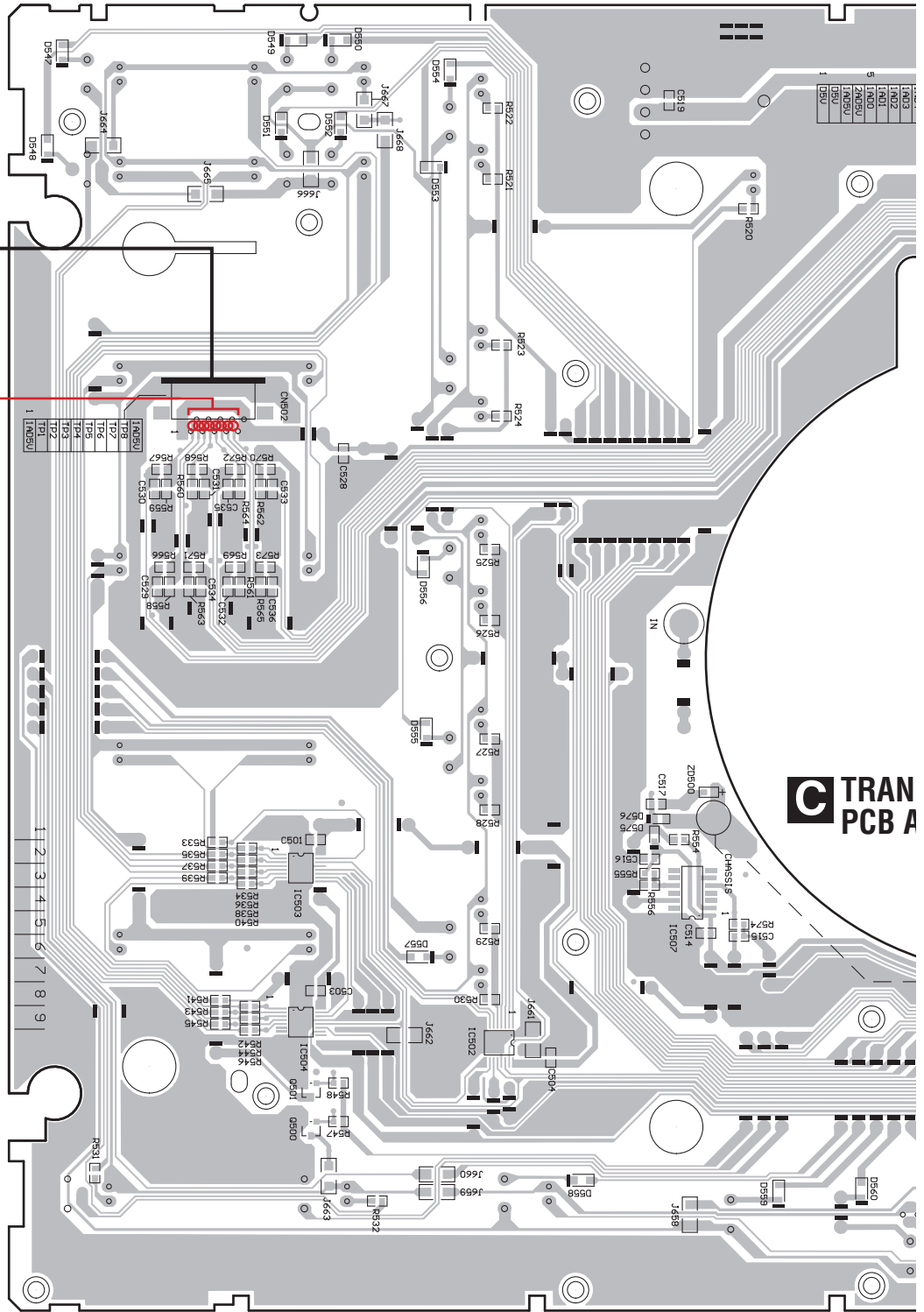

IC503
IC504
Q501
Q500

IC502

IC507

DDJ-SX

A
B
C
D
E
F

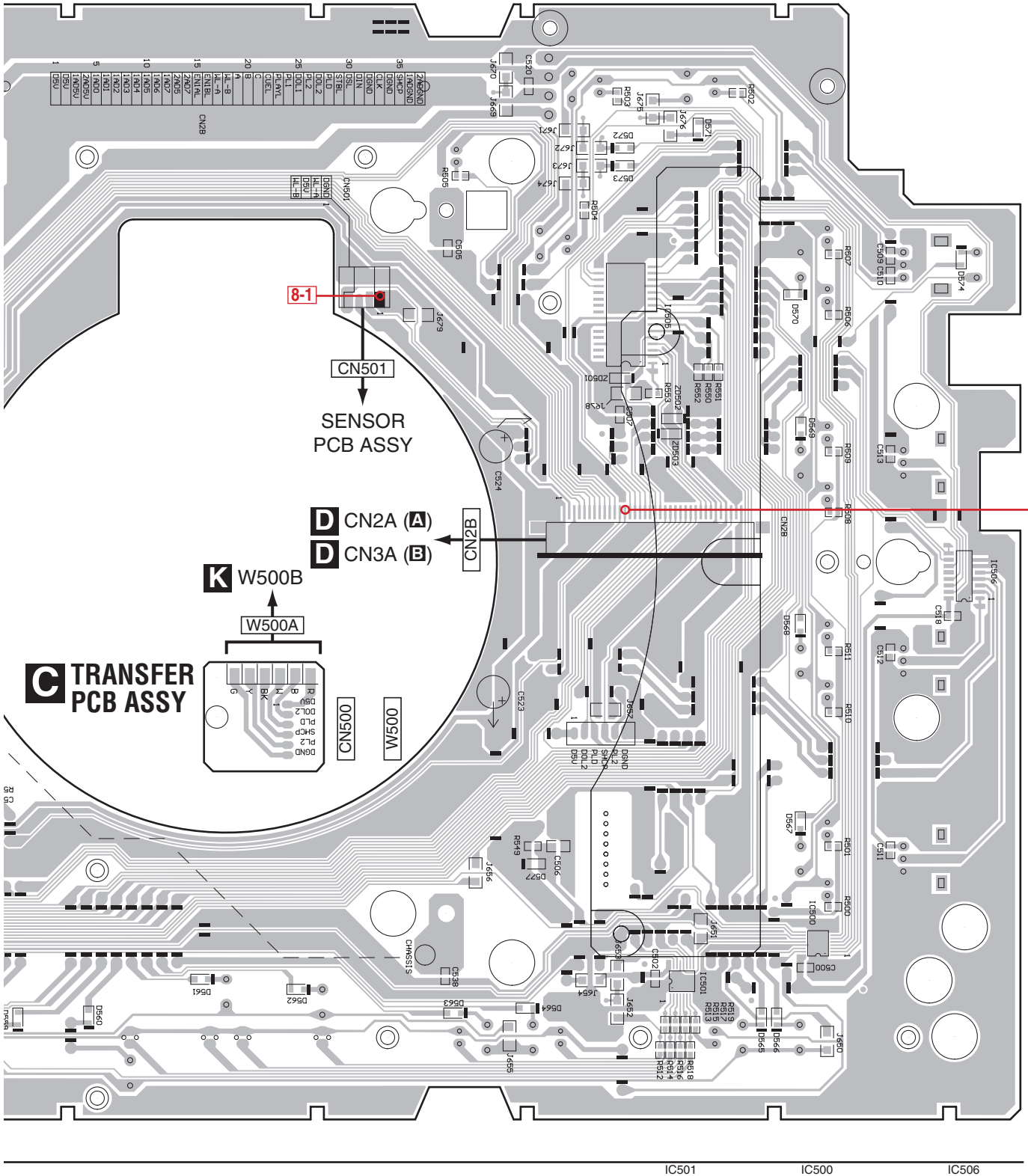

C TRANSFER PCB ASSY

8-1

CN501
SENSOR PCB ASSY

D CN2A (A)
D CN3A (B)

K W500B

W500A

CN500
W500

9-1

IC501 IC500 IC506

A B C

DDJ-SX

5 6 7 8

11.2 DSP, OUTPUT and BAL. PCB ASSYS

SIDE A

IC39
IC40

IC18
Q6 Q7

IC34

D DSP PCB ASSY

A CN2B

B CN2B

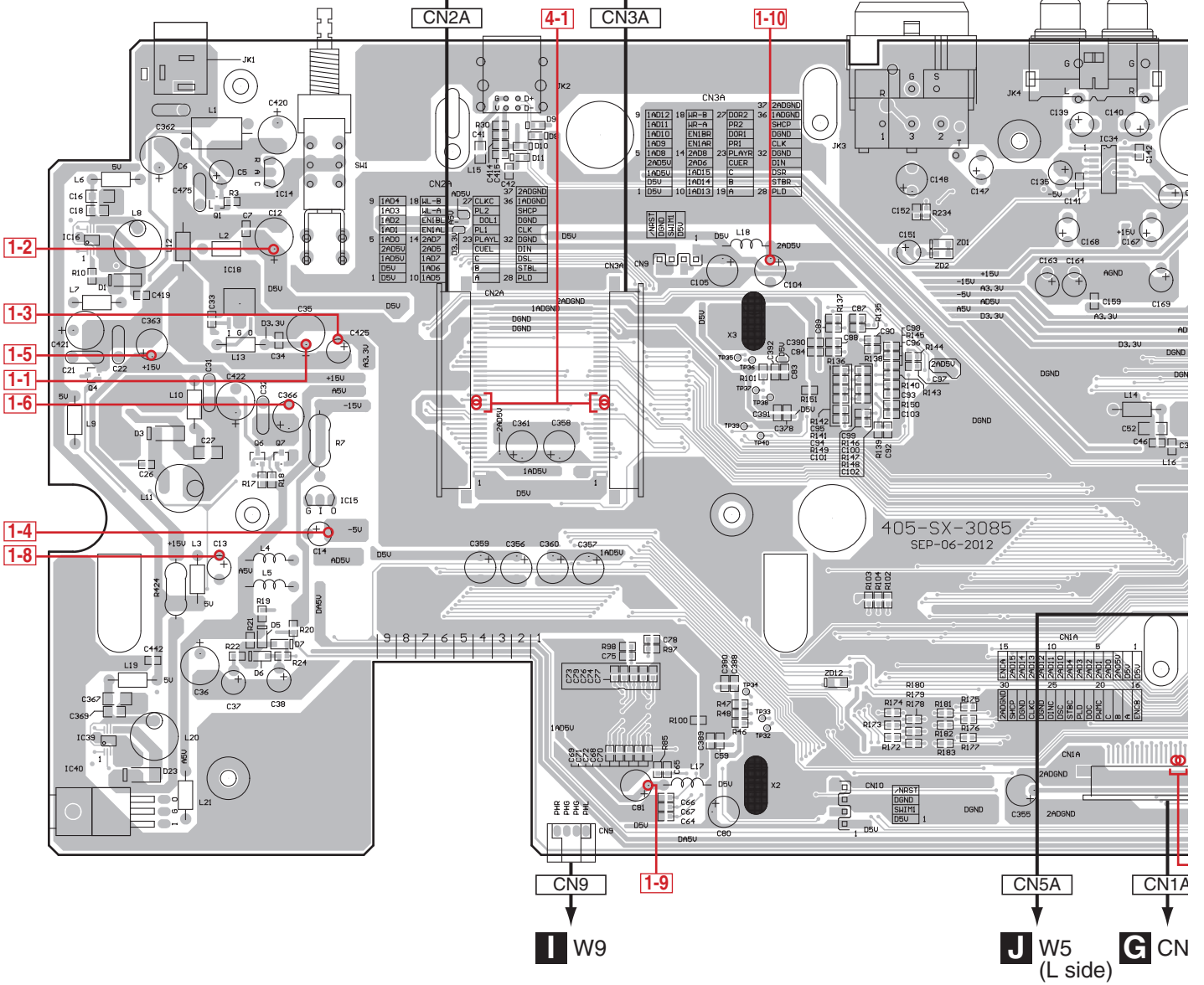

D

SIDE A

IC34

Q9 Q10
IC21

Q11

Q12 Q13
IC13

IC35

A

B

C

D

E

F

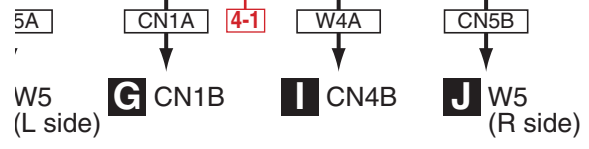
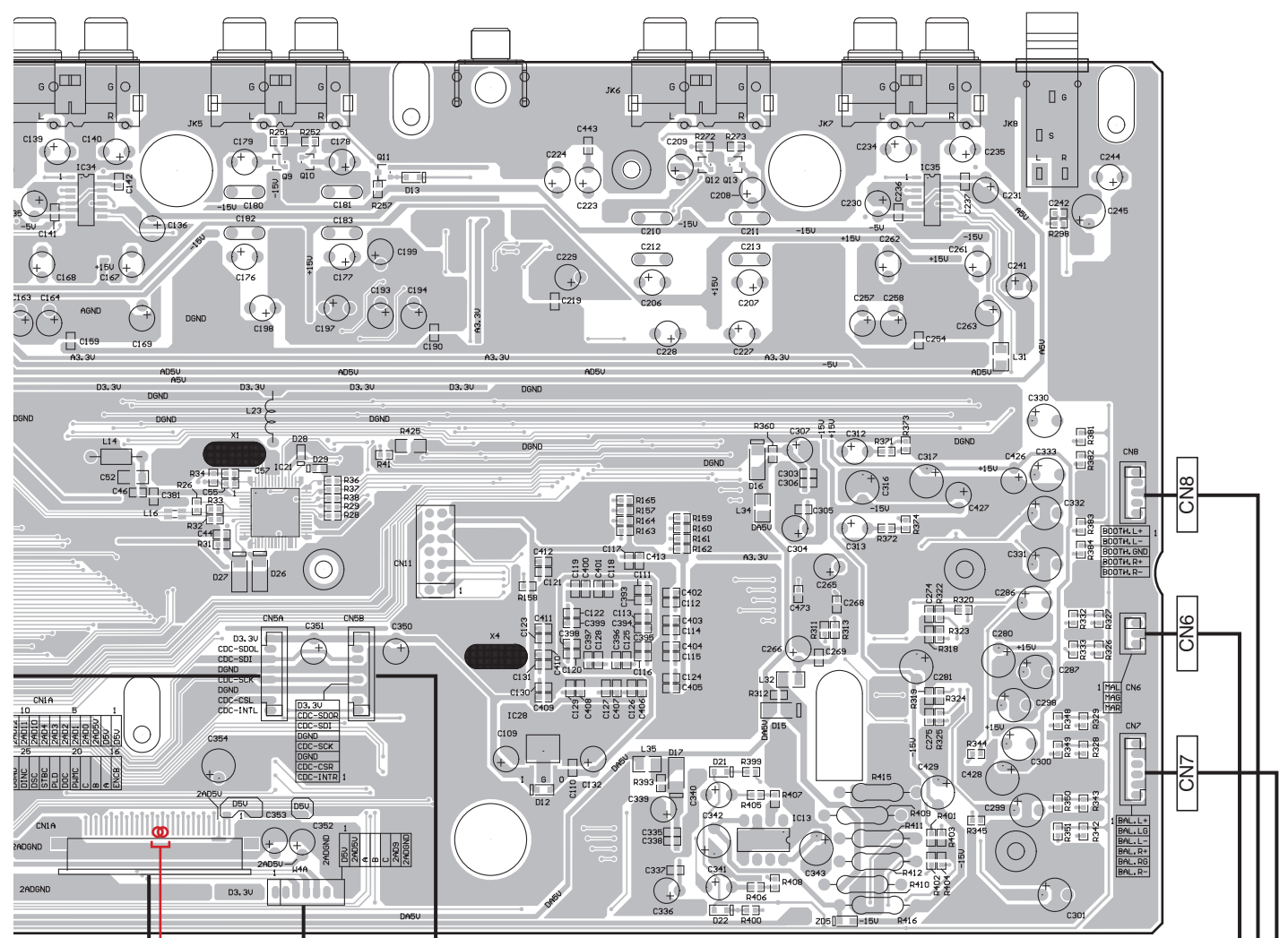

E OUTPUT PCB ASSY

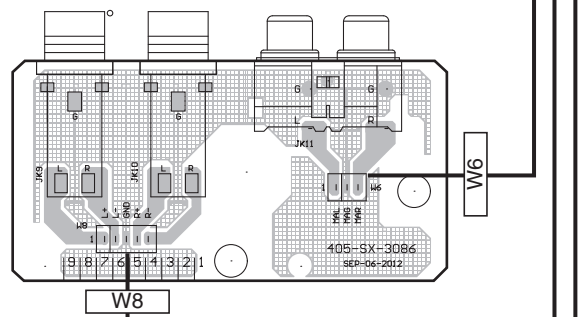

F BAL. PCB ASSY

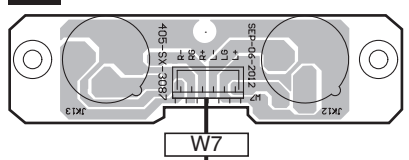

D E F

DDJ-SX

SIDE B

Q29-Q32 IC8	IC33 IC7 Q27	IC5	Q14	IC3	
Q15-Q18	IC12 IC11	IC37	IC16	IC32	IC31
Q19-Q22	IC9 Q28	IC36 Q33	IC29	IC22	IC20
Q23-Q26	IC10 Q35-Q38	Q34	IC38	IC27	IC1
					IC30

D DSP PCB ASSY

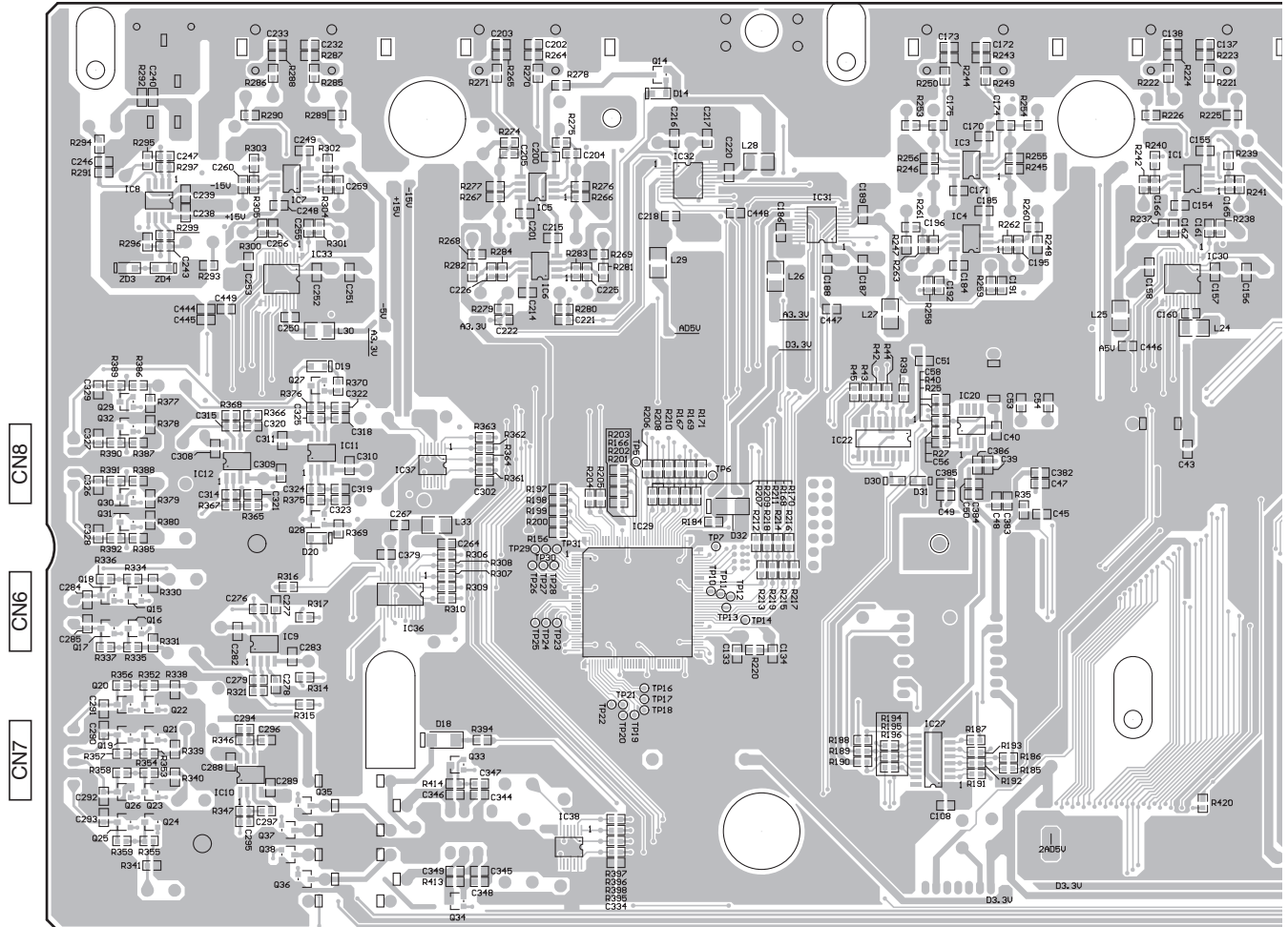

CN5B W4A CN1A CN6

E OUTPUT PCB ASSY

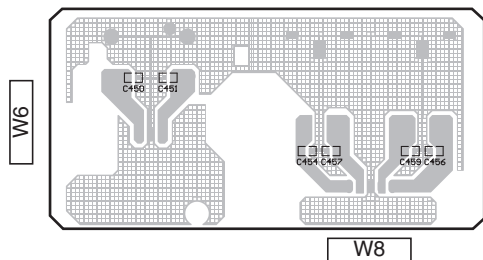

F BAL. PCB ASSY

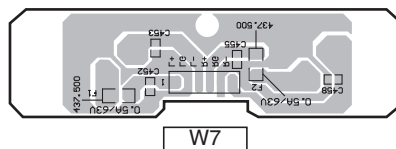

D E F

SIDE B

IC1
IC30

IC2
IC26

IC23
IC25

IC24

IC41

Q5 Q2
IC19

IC17 Q3

A

CN3A

CN2A

B

C

D

E

F

1-7

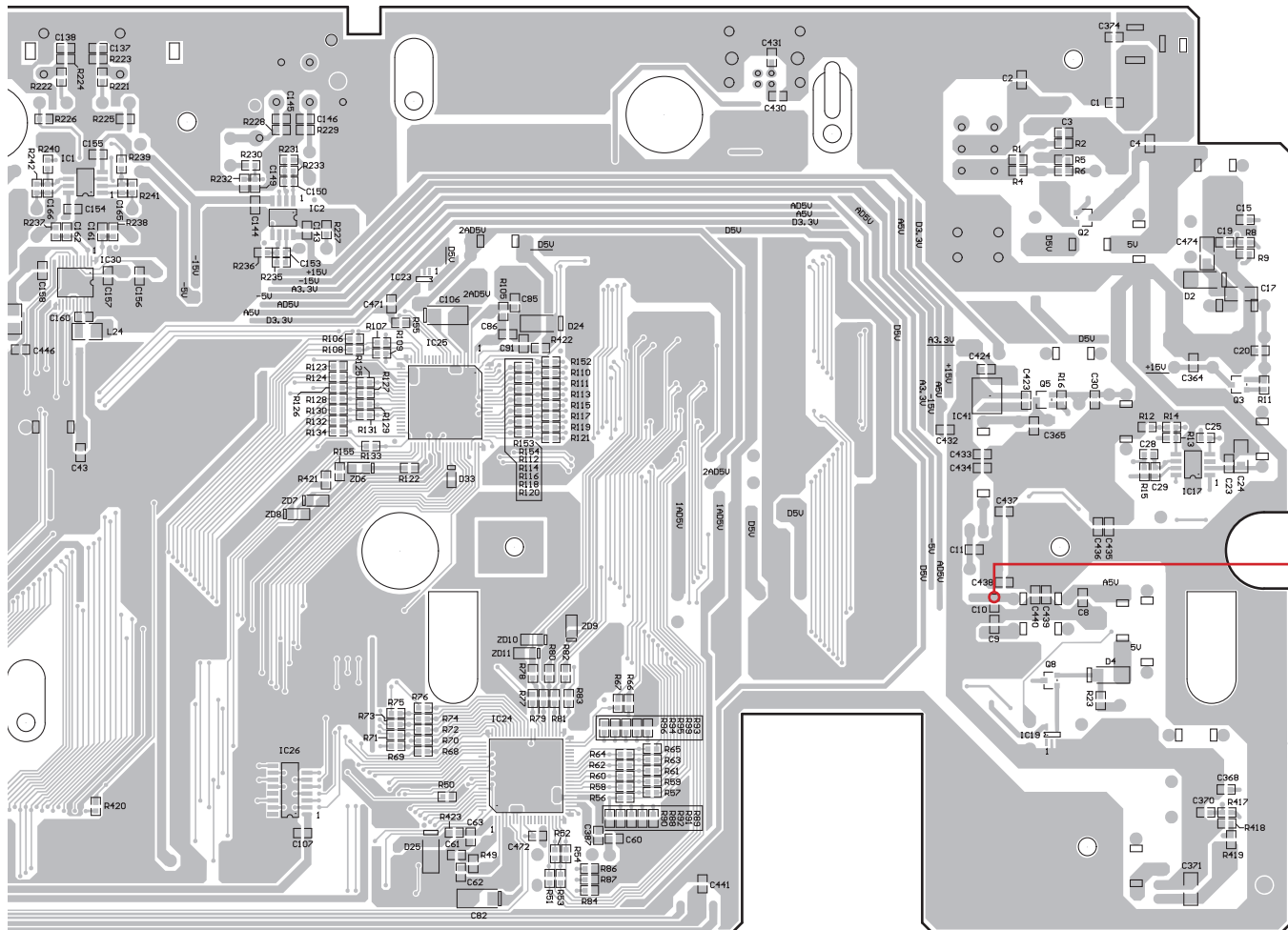

N1A

CN5A

CN9

11.3 MIX and CH FADER PCB ASSYS

SIDE A

G MIX PCB ASSY

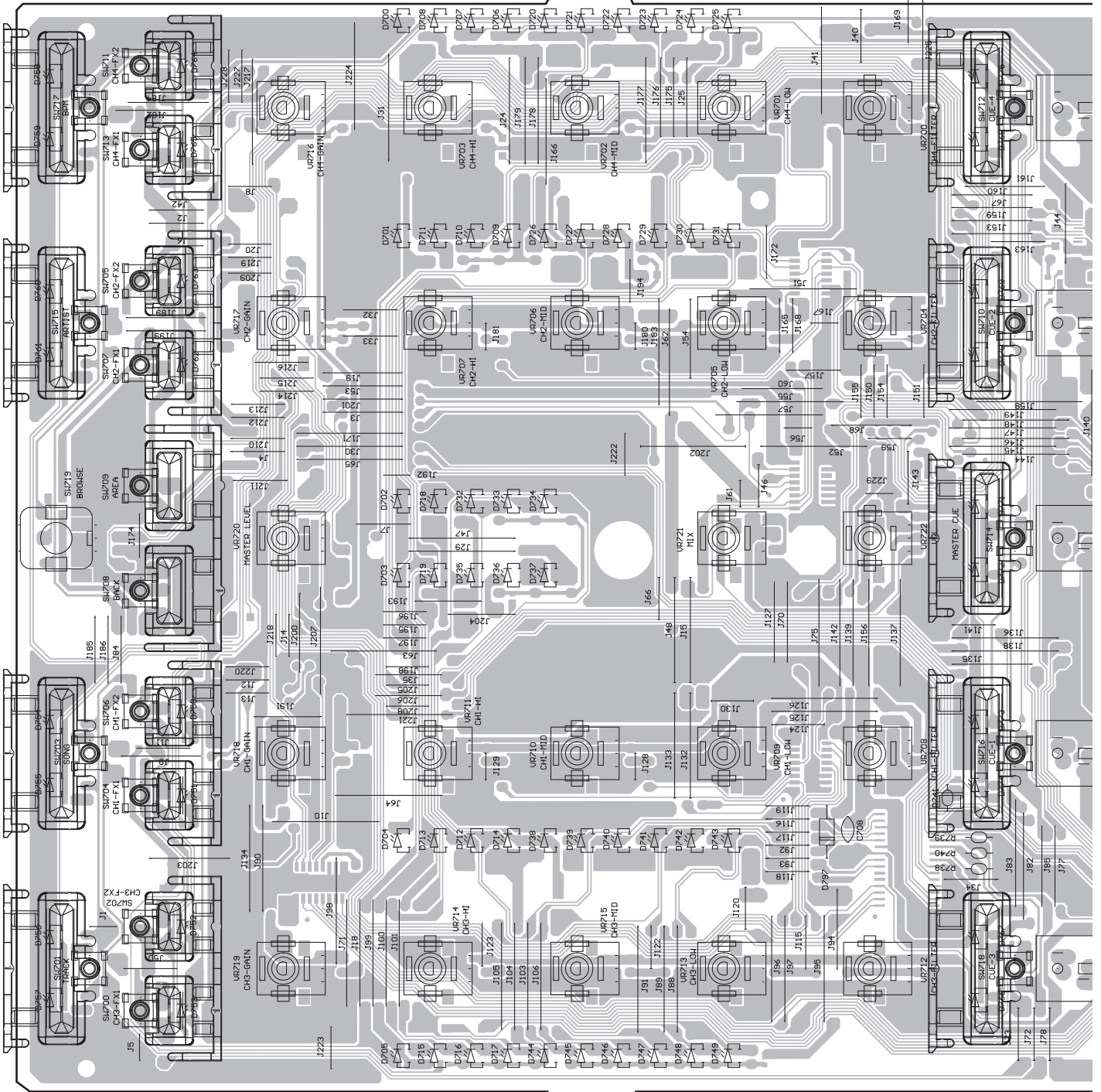

SIDE B

A
B
C
D
E
F

G MIX PCB ASSY

G CH FADER PCB ASSY

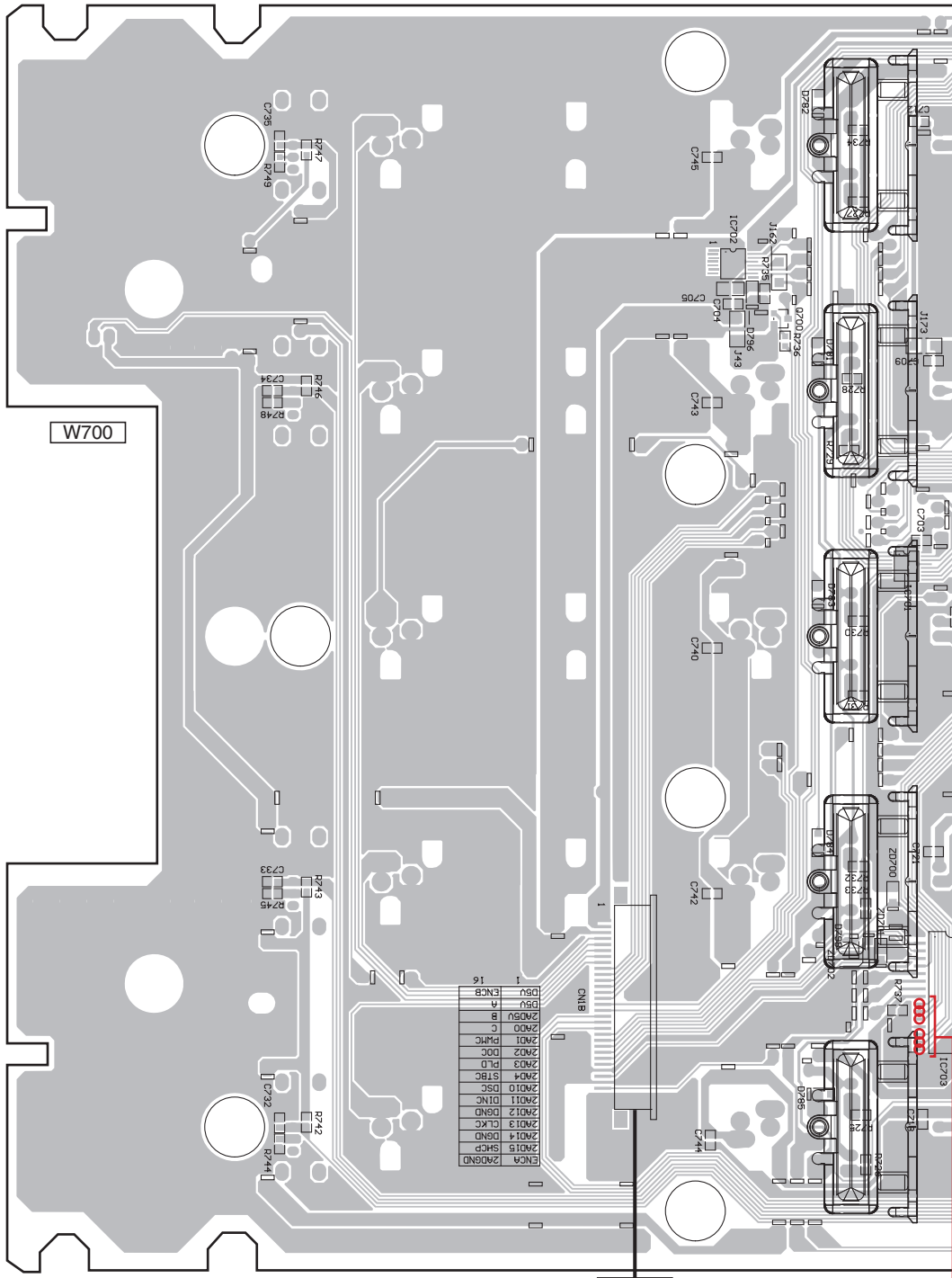
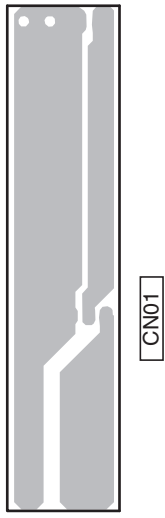

ENCA	ZN08ND
ZN015	SHP
ZN014	DND
ZN013	CLKC
ZN012	DND
ZN011	DINC
ZN010	DSC
ZN04	STRC
ZN03	PLD
ZN02	DOC
ZN01	PMFC
ZN00	C
ZN00	B
ZN00	A
ZN00	H
ZN00	U
ZN00	ENCB
ZN00	16

CN1B
D CN1A

IC702 Q700

IC7

G H

SIDE B

A
B
C
D
E
F

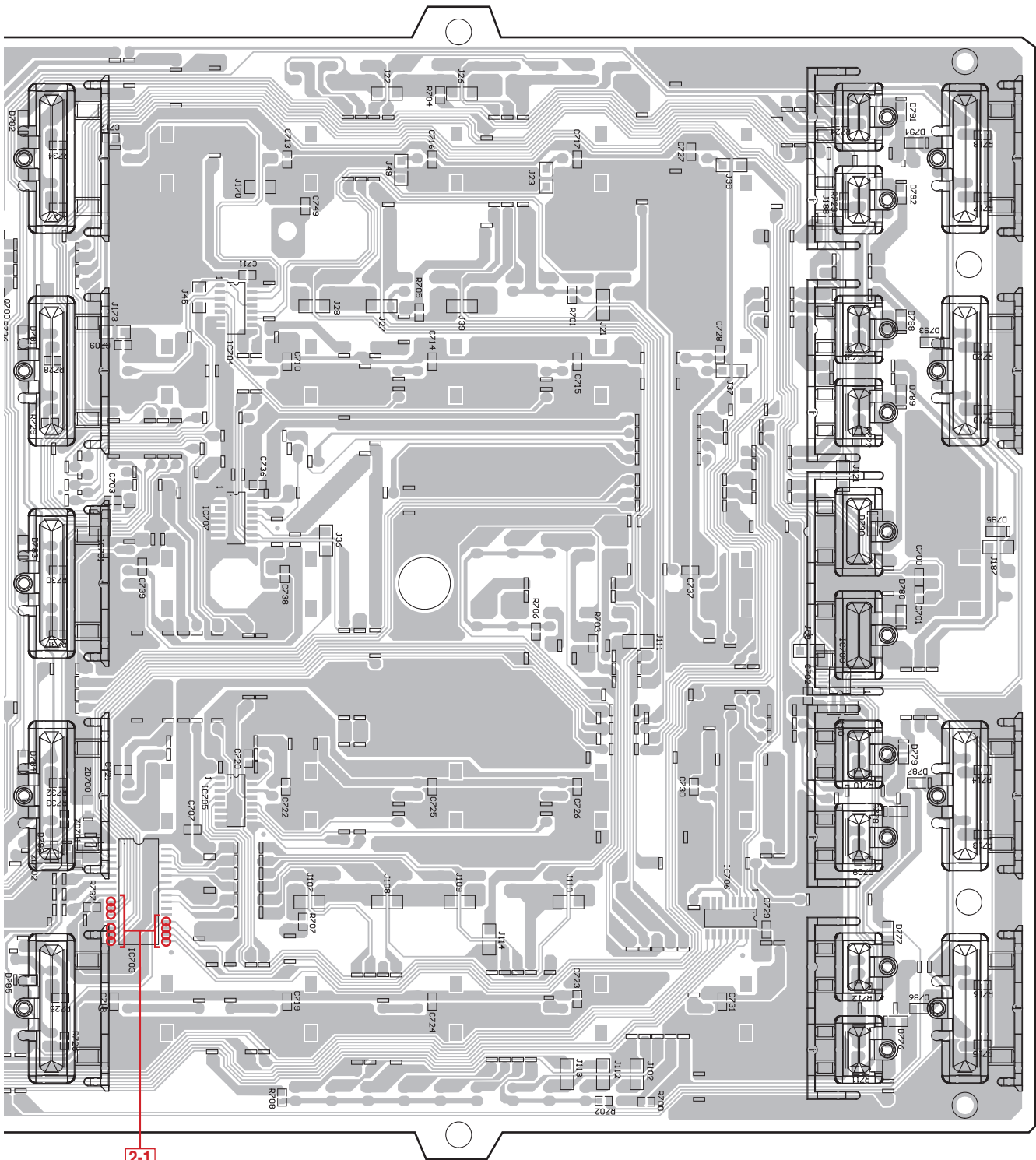

IC703 IC704
IC707 IC705

IC706

DDJ-SX



11.4 FRONT and TOUCH PCB ASSYS

SIDE A

I FRONT PCB ASSY

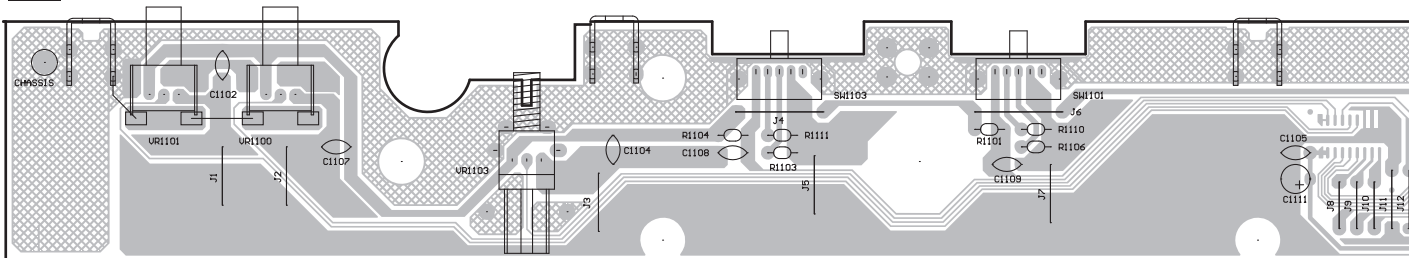

J TOUCH PCB ASSY

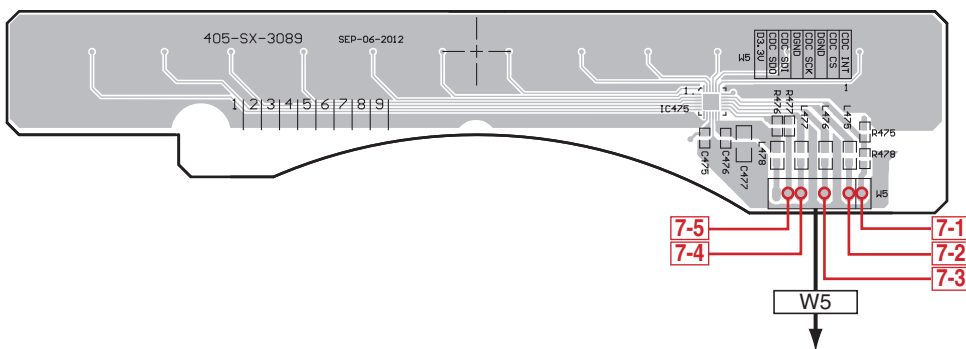

- D** CN5A (L side)
- D** CN5B (R side)

SIDE B

J TOUCH PCB ASSY

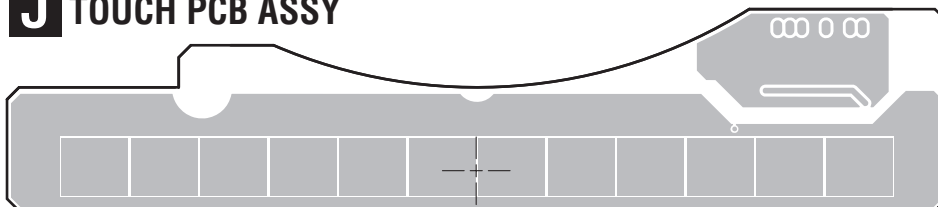

I FRONT PCB ASSY

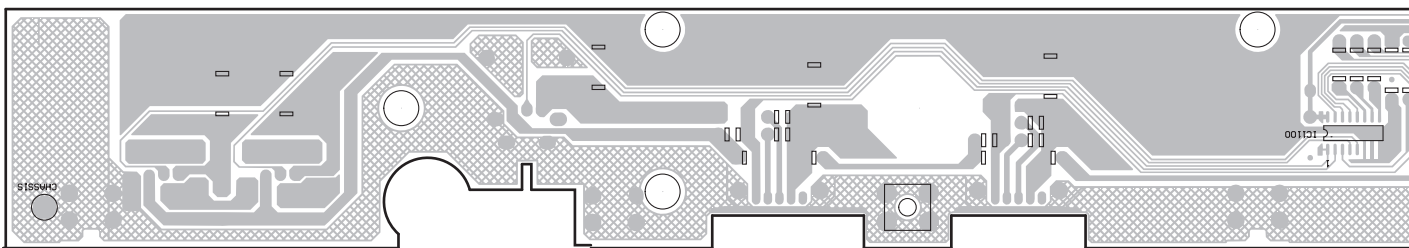

IC1100



SIDE A

A

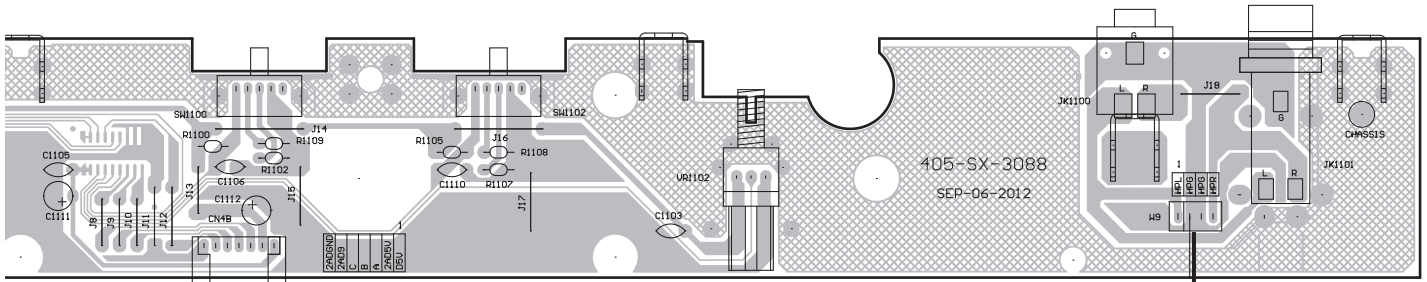

D W4A

D CN9

B

C

SIDE B

D

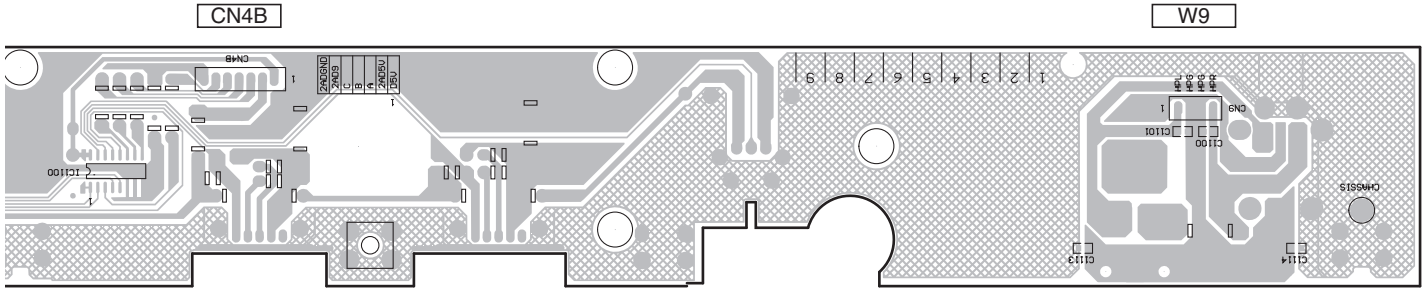

CN4B

W9

E

F

IC1100

DDJ-SX



11.5 LED PCB ASSY

SIDE A

SIDE A

K LED PCB ASSY

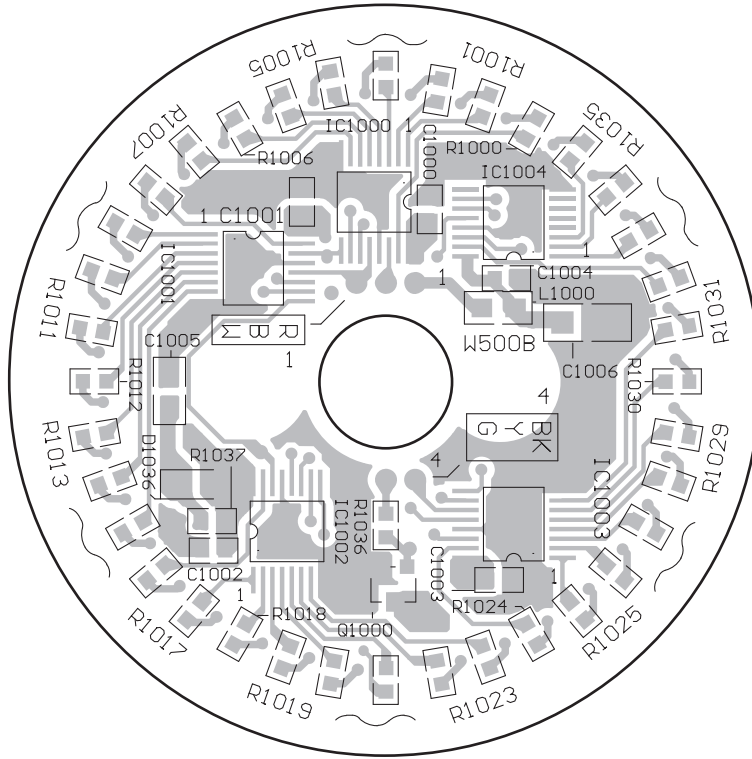

IC1000
IC1004
IC1001

IC1003
IC1002
Q1000

SIDE B

SIDE B

K LED PCB ASSY

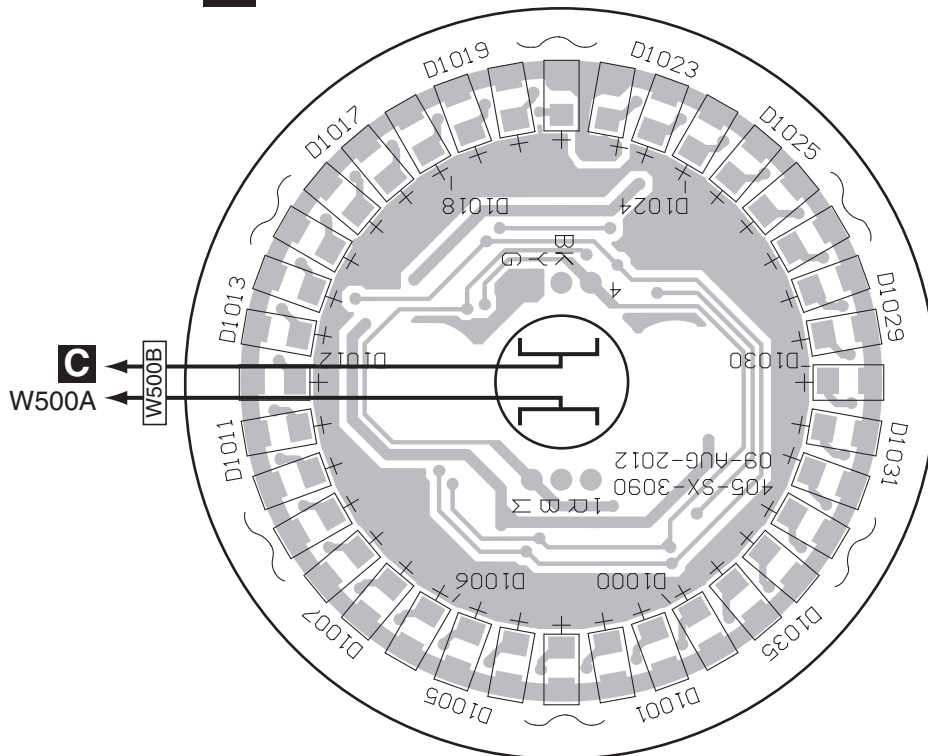

12. PCB PARTS LIST

NOTES: ● Parts marked by "NSP" are generally unavailable because they are not in our Master Spare Parts List.

● The Δ mark found on some component parts indicates the importance of the safety factor of the part. Therefore, when replacing, be sure to use parts of identical designation.

● Although the cables that are directly mounted on each PCB Assy are listed individually as electrical parts of the corresponding PCB Assy in the parts list, those cables are included with each PCB Assy for service when it is supplied.

Mark No. Description Part No.

LIST OF ASSEMBLIES

1..CONTROL PCB ASSY A	704-DDJS1-A421-HA
1..CONTROL PCB ASSY B	704-DDJS1-A454-HA
1..TRANSFER PCB ASSY	704-DDJS1-A429-HA
1..DSP PCB ASSY	704-DDJS1-A418-HA
1..OUTPUT PCB ASSY	704-DDJS1-A425-HA
1..BAL. PCB ASSY	704-DDJS1-A423-HA
1..MIX PCB ASSY	704-DDJS1-A417-HA
1..CH FADER PCB ASSY	704-DJM250-A032-HA
1..FRONT PCB ASSY	704-DDJS1-A424-HA
1..TOUCH PCB ASSY	704-DDJS1-A426-HA
1..LED PCB ASSY	704-DDJS1-A422-HA
1..SENSOR PCB ASSY	704-PDJ33-A007-HA

Mark No. Description Part No.

A CONTROL PCB ASSY A

B CONTROL PCB ASSY B

SEMICONDUCTORS

D514,515,523-530 LED(BLUE)	410-CDI600-357V-HA
D531 LED(YELLOW GREEN)	410-DJ5000-252V-HA
D500-513,518-522,541-546 LED(RED)	410-DJ5000-253V-HA
D532 LED (YELLOW)	410-HDJ2000-162V-HA
D533-540 LED(BLUE)	410-S1-421-HA
D516,517 LED(WHITE,3)	410-S1-422-HA
D574-574,577 SWITCHING DIODE	414-CD1000-075A-HA
ZD500,D575,576 ESD DIODE	414-RMP3-285-HA
D537-539,533-536,540 LED HOLDER	504-DD5250A-073-HA

MISCELLANEOUS

SW527,528 TACT SW	403-DDJLE-416-HA
SW529 ENCODER	403-DDJLE-418-HA
SW500-526 TACT SW	403-DDJLE-419-HA
CN501 4P SOCKET	404-DCM270E3-878A-HA
W500 6P CONNECTOR WIRE	404-S1-3759-HA
1P GROUND WIRE	406-S1-1239-HA
L500 INDUCTANCE	415-USOLOPA-342-HA

RESISTORS

R577 CARBON FILM RESISTOR	412-3113-078-HA
VR500-502 ROTARY VR(20KB)	418-S1-694-HA
P500 SLIDE VR(10*2)	418-S1-695-HA

CAPACITORS

C523,524 ELEC. CAPACITOR	413-CDN34-355-HA
C522 E/C	413-CDVD2001-265-HA
C525-527 ELEC.CAPACITOR	413-HMA2200-5017-HA
C508 ELEC. CAPACITOR	413-SPPW3-235-HA
C524 CUSHION	612-S1-448-HA

C TRANSFER PCB ASSY

There is no service parts.

Mark No. Description Part No.

D DSP PCB ASSY

SEMICONDUCTORS

Q4,7 TRANSISTOR	416-CDN88-044-HA
Q6 TRANSISTOR	416-CDN88-045-HA
Q1 TRANSISTOR	416-CTB200-166-HA
Q11,14 TRANSISTOR	416-CTB200-178-HA
Q2,3 TRANSISTOR	416-UDJ200-347-HA
Q9,10,12,13,15,16,21-24 TRANSISTOR	416-3000-378-HA
Q27-38 TRANSISTOR	416-3000-378-HA
D547-574,577 SWITCHING DIODE	414-CD1000-075A-HA
ZD1-5 ZENER DIODE	414-DDJLE-332-HA
D8-11,28-31 ESD DIODE	414-DJ1100G-207-HA
D33 ESD DIODE	414-RMP3-285-HA
D24-27,32 TVS DIODE	414-UDJ200-284-HA
D3,4,16-18,23 DIODE	414-007USB-148-HA

MISCELLANEOUS

JK8 JACK GROUND PLATE	300-300-1171-HA
FIXED PLATE(M3*P0.5)	300-4500-2010A-HA
SW1 POWER SWITCH	403-VP9812-162-HA
CN6 3P SOCKET	404-HP1010K-259A-HA
CN5A,5B 8P SOCKET	404-KT300-079A-HA
W9 4P CONNECTOR WIRE	404-S1-3757-HA
W4A 7P CONNECTOR WIRE	404-S1-3760-HA
CN8 5P SOCKET	404-1210S-094A-HA
CN7 6P SOCKET	404-3113-052A-HA
L16 TDK COMMON FILTERS	415-FU800-305-HA
L2,6,9,10,12-14,19,21 BEAD CORE	415-HV3500K-090-HA
L8,20 CORE	415-MC2-401-HA
L17,23 INDUCTOR(10UH T-26MM)	415-MPG100-047-HA
L11 CORE	415-PDJ33-381-HA
L4,5 INDUCTANCE	415-USOLOPA-342-HA
W9 EMI CORE(RI 14*8*10)	415-390-277-HA
JK1 DC POWER JACK	420-CDMIX1-078-HA
JK4-7 2P RCA JACK	420-HDJ7000-045-HA
JK3 MIC JACK	420-MH2-223-HA
JK8 MIC JACK	420-SMX211-137-HA
JK2 USB JACK	420-S1-377-HA
CN9,10 SERIES STRIP PINHEAD	424-HDJ9700-069-HA
X1 CRYSTAL (6MHz)	427-S1-143-HA
X2,3 CRYSTAL (24 MHz)	427-S1-144-HA
X4 CRYSTAL (24.576 MHz)	427-S1-145-HA
FIXED PLATE ASS'Y	703-200U-1170A-HA

RESISTORS

R409,410 CARBON FILM RESISTOR	412-CDG11-466-HA
R7 CARBON FILM RESISTOR	412-HMA2200-5019-HA
R415,416 CARBON FILM RESISTOR	412-HT801K-219-HA
R411,412 CARBON FILM RESISTOR	412-SA12-566-HA

Mark	No.	Description	Part No.
------	-----	-------------	----------

CAPACITORS

	C209,425 E/C	413-CDVD2001-265-HA
	C420-422 ELEC. CAPACITOR	413-DV300-292-HA
A	C109,169,199,299,263 ELEC.CAPACITOR	413-HMA2200-5017-HA
	C307,339 ELEC.CAPACITOR	413-HMA2200-5017-HA
	C167,168,197,198,227 ELEC.CAPACITOR	413-HT801K-191-HA
	C228,261,262 ELEC.CAPACITOR	413-HT801K-191-HA
	C81,104,354,355-359 ELEC.CAPACITOR	413-HT801K-192-HA
	C360,361 ELEC.CAPACITOR	413-HT801K-192-HA
	C13,148,245,298-301 ELEC.CAPACITOR	413-HT801K-193-HA
	C330-334 ELEC.CAPACITOR	413-HT801K-193-HA

	C6,12 ELEC.CAPACITOR	413-HT8015-169-HA
	C82,106 TANTALUM CAPACITOR	413-MAIE-1211-HA
B	C280,281 ELEC.CAPACITOR	413-MC6000-1191-HA
	C362 POLYESTER CAPACITOR	413-QSPAND-632-HA
	C5,139,140,163,164,176 ELEC. CAPACITOR	413-SPPW3-235-HA

	C177,193,194,206,207 ELEC. CAPACITOR	413-SPPW3-235-HA
	C223,224,234,235,241 ELEC. CAPACITOR	413-SPPW3-235-HA
	C257,258,266,304,312 ELEC. CAPACITOR	413-SPPW3-235-HA
	C313,336,340,341 ELEC. CAPACITOR	413-SPPW3-235-HA
	C38,147,244 ELEC. CAPACITOR	413-SPPW3-236-HA

	C286,287,316,342,343 ELEC. CAPACITOR	413-SPPW3-237-HA
	C363,366,428,429 ELEC. CAPACITOR	413-SPPW3-237-HA
	C475 POLYESTER ACPACITOR	413-X050-1058-HA
C	C35,36,105 ELEC. CAPACITOR	413-007USB-828-HA
	C180,181,210,211 POLYESTER CAPACITOR	413-205-958A-HA

	C182,183,212,213 POLYESTER CAPACITOR	413-900-934A-HA
--	--------------------------------------	-----------------

E OUTPUT PCB ASSY**MISCELLANEOUS**

	JACK GROUND PLATE	300-300-1171-HA
	W6 3P CONNECTOR WIRE	404-S1-3754-HA
	W8 5P CONNECTOR WIRE	404-S1-3758-HA
	W8 FERRITE CORE	415-VP9812-221-HA
D	W6 EMI CORE(RI 14*8*10)	415-390-277-HA
	JK11 2P RCA JACK	420-HDJ7000-045-HA
	JK9,10 3P PHONE JACK	420-HMJ1001-5034-HA

F BAL. PCB ASSY**MISCELLANEOUS**

	W7 6P CONNECTOR WIRE	404-S1-3755-HA
	JK12,13 XLR JACK	420-S1-375-HA
⚠	F1,F2 SMD FUSE	422-S1-111-HA

G MIX PCB ASSY**SEMICONDUCTORS**

	D754,755,760,761 LED(BLUE)	410-CDI600-357V-HA
	D720-749 LED(YELLOW GREEN)	410-DJ5000-252V-HA
	D700-705,750-753,762-775 LED(RED)	410-DJ5000-253V-HA
	D706-719 LED (YELLOW)	410-HDJ2000-162V-HA
	D516,517 LED(WHITE,3)	410-S1-422-HA

	D776-796 SWITCHING DIODE	414-CD1000-075A-HA
	D797 DIODE	414-DV300-5014-HA
	D798 ESD DIODE	414-RMP3-285-HA

MISCELLANEOUS

	SW719 ENCODER	403-DDJLE-418-HA
	SW700-718 TACT SW	403-DDJLE-419-HA

Mark	No.	Description	Part No.
------	-----	-------------	----------

	SW720-723 SLIDE SW	403-ID-333-HA
	3P SOCKET	404-HMD5000-784A-HA
	W700 CONNECTOR WIRE	404-S1-3756-HA

RESISTORS

	R741 CARBON FILM RESISTOR	412-KM300-116-HA
	R739,740 CARBON FILM RESISTOR	412-3113-068-HA
	VR700-715,722 ROTARY VR(20KB)	418-S1-693-HA
	VR716-721 ROTARY VR(20KB)	418-S1-694-HA
	VR723-727 SLIDE VR	418-S1-701-HA

CAPACITORS

	C746 ELEC. CAPACITOR	413-DV300-5155-HA
	C706,747,748 ELEC.CAPACITOR	413-HMA2200-5017-HA
	C708 CERAMIC CAPACITOR	413-3113-035-HA

H CH FADER PCB ASSY

There is no service parts.

I FRONT PCB ASSY**MISCELLANEOUS**

	FIXED PLATE	300-SC1M-1621-HA
	PH FIXED PLATE	300-S1-2061-HA
	ROTARY VR FIXED SHEET	300-TU3-1585-HA
	FIXED PLATE(M3*P0.5)	300-4500-2010A-HA
	VR FIXED PLATE	300-6000-1874-HA

	SW1100-1103 SLIDE SW	403-S1-420-HA
	CN9 4P SOCKET	404-DCM270E3-878A-HA
	CN4B 7P SOCKET	404-HMD5000-785A-HA
	CHASSIS*2 1P GROUND WIRE	406-S1-1240-HA
	JK1100 HEADPHONE JACK	420-HDJ7100-063-HA

	JK1101 3P PHONE JACK	420-HMJ1001-5034-HA
--	----------------------	---------------------

RESISTORS

	R1100-1107 METAL FILM RESISTOR	412-DFX1-653-HA
	R1108-1111 CARBON FILM RESISTOR	412-DV300-291-HA
	VR1100,1101 ROTARY VR	418-DJAI-516-HA
	VR1102,1103 HIDDEN VR(20KB)	418-S1-692-HA

CAPACITORS

	C1111,1112 E/C	413-CDVD2001-265-HA
	C1102-1110 CERAMIC CAPACITOR	413-3113-035-HA

J TOUCH PCB ASSY**MISCELLANEOUS**

	W5 8P CONNECTOR WIRE	404-S1-3761-HA
--	----------------------	----------------

K LED PCB ASSY**MISCELLANEOUS**

	WIRE(RED)	407-S1-307-HA
	WIRE(BLUE)	407-S1-308-HA
	WIRE(WHITE)	407-S1-309-HA
	WIRE(BLACK)	407-S1-310-HA
	WIRE(GREEN)	407-S1-311-HA

	WIRE(YELLOW)	407-S1-312-HA
--	--------------	---------------

SENSOR PCB ASSY

	M301 4P CONNECTOR WIRE	404-PDJ33-3591V-HA
--	------------------------	--------------------