

Service Manual

ORDER NO.
RRV4593

DJ CONTROLLER

DDJ-SZ-N

THIS MANUAL IS APPLICABLE TO THE FOLLOWING MODEL(S) AND TYPE(S).

Model	Type	Power Requirement	Remarks
DDJ-SZ-N	UXJCB	AC 100 V to 240 V	
DDJ-SZ-N	LSYXJ8	AC 100 V to 240 V	

This service manual should be used together with the following manual(s).

Model No.	Order No.	Remarks
DDJ-SZ/UXJCB	RRV4510	DDJ-SZ/LSYXJ8

For SPECIFICATIONS and PANEL FACILITIES, refer to the operating instructions.

This product is a limited-production model derived from the DDJ-SZ (base model) in a different color.

This product is the same as the DDJ-SZ, except for the colors.

The major changes are as shown below.

Exterior panels: Changed to gold

When replacing the above-mentioned parts, be sure to use the parts described in this manual.

1. CONTRAST OF MISCELLANEOUS PARTS

NOTES: ● Parts marked by "NSP" are generally unavailable because they are not in our Master Spare Parts List.

● The Δ mark found on some component parts indicates the importance of the safety factor of the part. Therefore, when replacing, be sure to use parts of identical designation.

● Screws adjacent to ∇ mark on product are used for disassembly.

● For the applying amount of lubricants or glue, follow the instructions in this manual.

(In the case of no amount instructions, apply as you think it appropriate.)

● Nos. indicate the pages and Nos. in the service manual for the base model.

● When ordering resistors, first convert resistance values into code form as shown in the following examples.

Ex.1 When there are 2 effective digits (any digit apart from 0), such as 560 ohm and 47k ohm (tolerance is shown by J=5%, and K=10%).

560 Ω \rightarrow 56 x 10¹ \rightarrow 561 RD1/4PU561J
 47k Ω \rightarrow 47 x 10³ \rightarrow 473 RD1/4PU473J
 0.5 Ω \rightarrow R50 RN2HR50K
 1 Ω \rightarrow 1R0 RS1P1R0K

Ex.2 When there are 3 effective digits (such as in high precision metal film resistors).

5.62k Ω \rightarrow 562 x 10¹ \rightarrow 5621 RN1/4PC5621F

CONTRAST TABLE

DDJ-SZ-N/UXJCB

DDJ-SZ/UXJCB and DDJ-SZ-N/UXJCB and DDJ-SZ-N/LSYXJ8 are constructed the same except for the following:

Mark	No.	Symbol and Description	DDJ-SZ/UXJCB	DDJ-SZ-N/UXJCB	DDJ-SZ-N/LSYXJ8	Remarks
PCB ASSEMBLIES						
NSP		1..JACK ASSY	DWM2520	DWM2560	DWM2560	
	P79-3	2..AIJK ASSY	DWX3536	DWX3659	DWX3659	
	P79-4	2..AOJK ASSY	DWX3537	DWX3660	DWX3660	
PACKING SECTION						
Δ	P75-2	Power Cord	DDG1108	DDG1108	ADG1244	
	P75-4	Operating Instructions (Basic Edition) (En)	DRH1247	DRH1301	Not used	
	P75-5	Operating Instructions (Basic Edition) (En, Fr, De, It, Nl, Es, Pt, Ru)	Not used	Not used	DRH1302	
	P75-10	Packing Case	DHG3305	DHG3404	DHG3403	
NSP	P75-13	Warranty Card	Not used	Not used	ARY7158	
TOP and CHASSIS SECTION						
	P77-10	Knob/FRE	DAA1309	DAA1343	DAA1343	
	P77-14	Plate/MIX	DAH2976	DAH3017	DAH3017	
	P77-15	Plate/DEL	DAH2982	Not used	Not used	
	P77-15	Plate	Not used	DEA1033	DEA1033	*1
	P77-16	Plate/DER	DAH2983	DAH3019	DAH3019	
	P77-42	Screw	CPZ26P080FTB	DBA1444	DBA1444	
NSP		DS Tape	Not used*2	DEH1064	DEH1064	No. 1
PANEL and BUTTON SECTION						
	P85-1	Control Panel	DNK6285	DNK6402	DNK6402	
	P85-2	Sheet/FR	DAH2991	DAH3021	DAH3021	
	P85-6	Button/PLY	DAC2982	DAC3078	DAC3078	
		Sheet/RE	DAH2997	DAH3022	DAH3022	
JOG DIAL SECTION						
	P87-18	Plate/JOG	DAH2915	DAH3020	DAH3020	
	P87-39	Jog Dial/B	DNK6272	DNK6403	DNK6403	

Notes : For PCB ASSEMBLIES, Refer to "CONTRAST OF PCB ASSEMBLIES".

The numbers in the remarks column correspond to the numbers on the "EXPLODED VIEWS".

*1 The serial No. is printed on the plate of the product model, but the service part DEA1033 is blank on the point.

*2 The DS Tape DEH1064 is applied to mass-production models of the base model by the design change.

Note:

*1 The serial No. is printed on the plate of the product model, but the service part DEA1033 is blank on the point.

Product Model(Printed Serial No.)

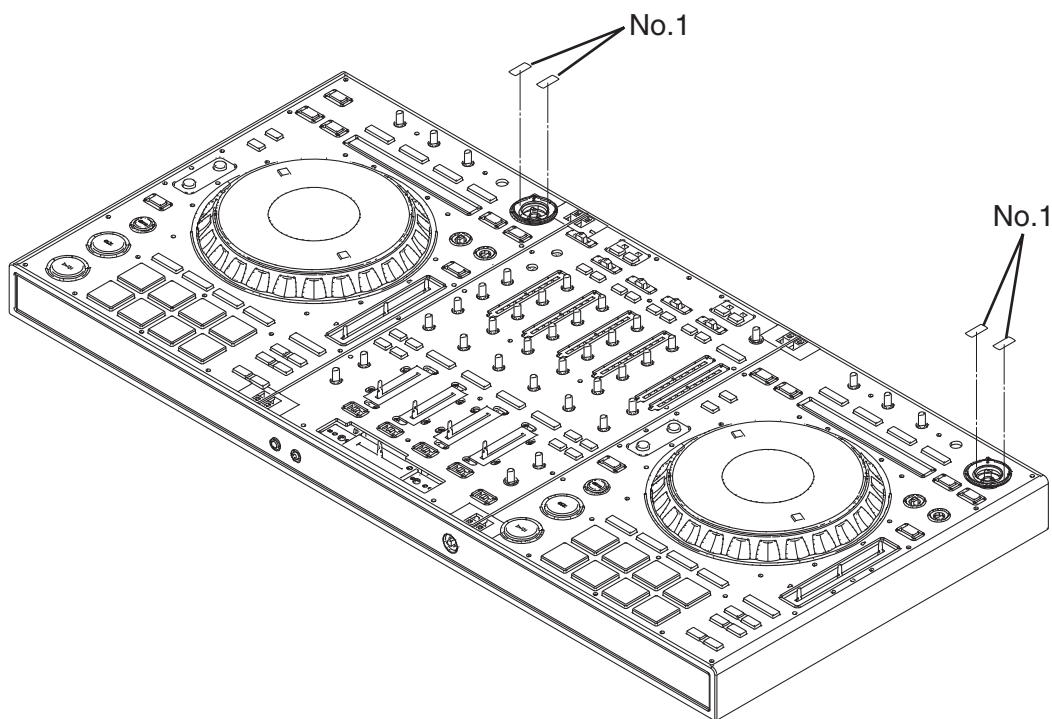

Service Parts(Without Serial No.)

**EXPLODED VIEWS****DS-Tape****CONTRAST OF PCB ASSEMBLIES****B F AIJK ASSY**

DWX3536 and DWX3659 are constructed the same except for the following:

Mark	Symbol and Description	DWX3536	DWX3659	Remarks
	JA101, JA302	DKB1083	DKB1112	Changed to gilding jack
	JA102, JA301	DKB1103	DKB1119	Changed to gilding jack
	JA502	DKN1653	DKN1622	Changed to gilding jack

The mounting positions of the additional parts are described in the circuit diagram and PCB diagram of the parent manual.

C F AOJK ASSY

DWX3537 and DWX3660 are constructed the same except for the following:

Mark	Symbol and Description	DWX3537	DWX3660	Remarks
	JA703	AKB7181	DKB1120	Changed to gilding jack
	JA901, JA902	DKN1653	DKN1622	Changed to gilding jack

Design Changes from the Base Model

A

B

C

D

E

F

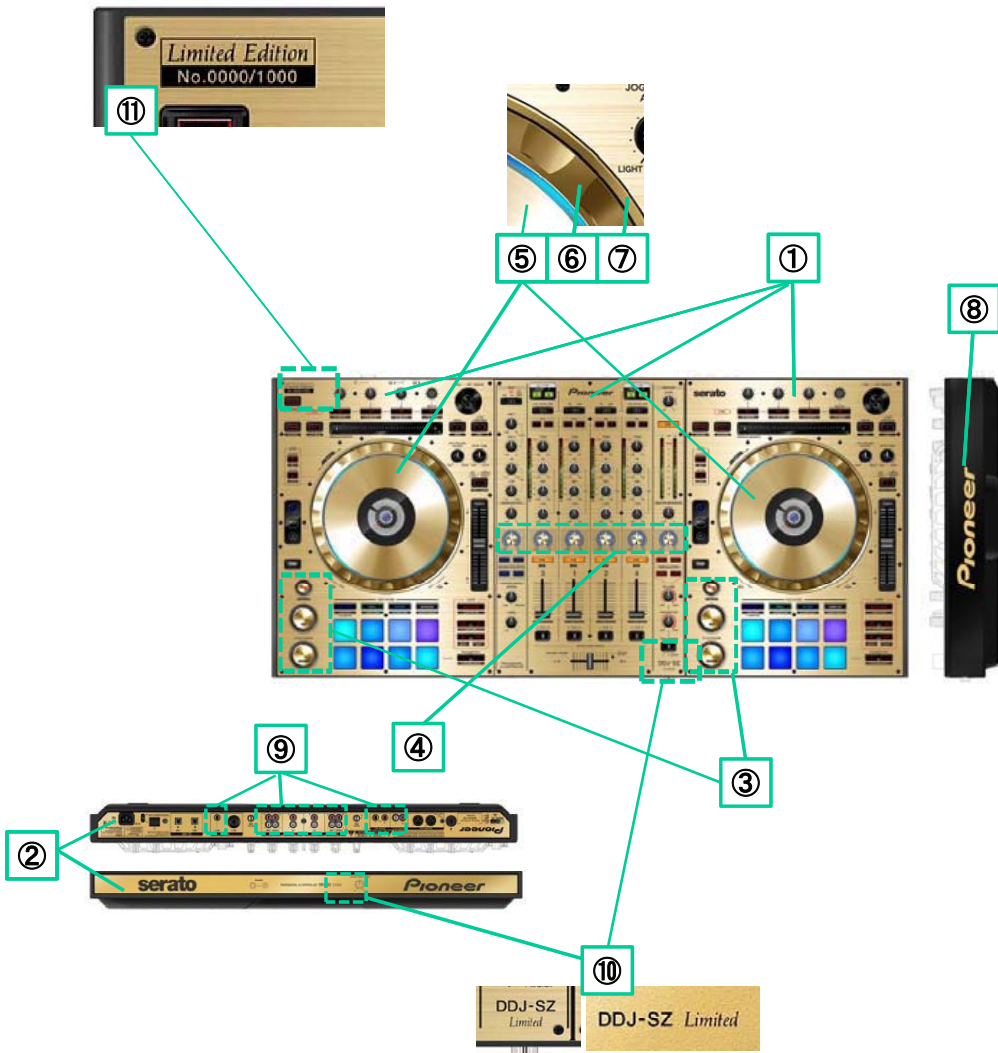

Changes from the Base Model

1. Change in colors of the three aluminum upper panels from black to gold
2. Change in colors of the front and rear panels from black to gold
3. Change in plating colors for the PLAY/CUE/SHIFT buttons from silver to gold
4. Change in plating colors for the Effect controls from silver to gold
5. Change in colors of the Jog aluminum plate from silver to gold
6. Change in colors of the Jog dial from silver to gold
7. Change in colors of the Jog ring from silver to gold
8. Change in colors of the Pioneer logo on the side panel from silver to gold
9. Change in plating colors for the connectors from silver to gold
10. The word "Limited" has been added adjacent to the model No. prints.
11. Addition of a serial-No. print. A serial-No. plate will be added or a serial No. will be directly engraved on the aluminum upper panel.