

Service Manual

Pioneer



• DV-444

ORDER NO.
RRV2490

DVD PLAYER

DV-444 DV-440

THIS MANUAL IS APPLICABLE TO THE FOLLOWING MODEL(S) AND TYPE(S).

Type	Model		Power Requirement	Region No.	Remarks
	DV-444	DV-440			
KUXQ	○	○	AC120V	1	
KCXQ	○	-	AC120V	1	
KUXJ	-	○	AC120V	1	
KCXJ	-	○	AC120V	1	

CONTENTS

1. SAFETY INFORMATION	2	7. GENERAL INFORMATION	54
2. EXPLODED VIEWS AND PARTS LIST	3	7.1 DIAGNOSIS	54
3. BLOCK DIAGRAM AND SCHEMATIC DIAGRAM ...	10	7.1.1 SELF-DIAGNOSTIC FUNCTION OF PICKUP DEFECTIVE	54
4. PCB CONNECTION DIAGRAM	33	7.1.2 TEST POINTS LOCATION	55
5. PCB PARTS LIST	43	7.1.3 TEST MODE SCREEN DISPLAY	56
6. ADJUSTMENT	48	7.1.4 TROUBLE SHOOTING	60
		7.1.5 ERROR CODE	61
		7.1.6 DISASSEMBLY	65
		7.2 PARTS	71
		7.2.1 IC	71
		7.2.2 FL DISPLAY	93
		8. PANEL FACILITIES AND SPECIFICATIONS	94

PIONEER CORPORATION 4-1, Meguro 1-chome, Meguro-ku, Tokyo 153-8654, Japan
PIONEER ELECTRONICS SERVICE, INC. P.O. Box 1760, Long Beach, CA 90801-1760, U.S.A.
PIONEER EUROPE NV Haven 1087, Keetberglaan 1, 9120 Melsele, Belgium
PIONEER ELECTRONICS ASIACENTRE PTE. LTD. 253 Alexandra Road, #04-01, Singapore 159936
 © PIONEER CORPORATION 2001

1. SAFETY INFORMATION

This service manual is intended for qualified service technicians ; it is not meant for the casual do-it-yourselfer. Qualified technicians have the necessary test equipment and tools, and have been trained to properly and safely repair complex products such as those covered by this manual. Improperly performed repairs can adversely affect the safety and reliability of the product and may void the warranty. If you are not qualified to perform the repair of this product properly and safely, you should not risk trying to do so and refer the repair to a qualified service technician.



WARNING

This product contains lead in solder and certain electrical parts contain chemicals which are known to the state of California to cause cancer, birth defects or other reproductive harm.

Health & Safety Code Section 25249.6 – Proposition 65



NOTICE

(FOR CANADIAN MODEL ONLY)

Fuse symbols  (fast operating fuse) and/or  (slow operating fuse) on PCB indicate that replacement parts must be of identical designation.

REMARQUE

(POUR MODÈLE CANADIEN SEULEMENT)

Les symboles de fusible  (fusible de type rapide) et/ou  (fusible de type lent) sur CCI indiquent que les pièces de remplacement doivent avoir la même désignation.

(FOR USA MODEL ONLY)

1. SAFETY PRECAUTIONS

The following check should be performed for the continued protection of the customer and service technician.

LEAKAGE CURRENT CHECK

Measure leakage current to a known earth ground (water pipe, conduit, etc.) by connecting a leakage current tester such as Simpson Model 229-2 or equivalent between the earth ground and all exposed metal parts of the appliance (input/output terminals, screwheads, metal overlays, control shaft, etc.). Plug the AC line cord of the appliance directly into a 120V AC 60Hz outlet and turn the AC power switch on. Any current measured must not exceed 0.5mA.

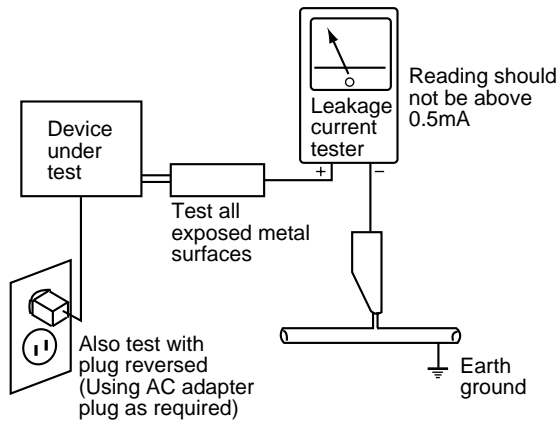

AC Leakage Test

ANY MEASUREMENTS NOT WITHIN THE LIMITS OUTLINED ABOVE ARE INDICATIVE OF A POTENTIAL SHOCK HAZARD AND MUST BE CORRECTED BEFORE RETURNING THE APPLIANCE TO THE CUSTOMER.

2. PRODUCT SAFETY NOTICE

Many electrical and mechanical parts in the appliance have special safety related characteristics. These are often not evident from visual inspection nor the protection afforded by them necessarily can be obtained by using replacement components rated for voltage, wattage, etc. Replacement parts which have these special safety characteristics are identified in this Service Manual.

Electrical components having such features are identified by marking with a Δ on the schematics and on the parts list in this Service Manual.

The use of a substitute replacement component which does not have the same safety characteristics as the PIONEER recommended replacement one, shown in the parts list in this Service Manual, may create shock, fire, or other hazards.

Product Safety is continuously under review and new instructions are issued from time to time. For the latest information, always consult the current PIONEER Service Manual. A subscription to, or additional copies of, PIONEER Service Manual may be obtained at a nominal charge from PIONEER.

2. EXPLODED VIEWS AND PARTS LIST

- NOTES: ● Parts marked by "NSP" are generally unavailable because they are not in our Master Spare Parts List.
 ● The Δ mark found on some component parts indicates the importance of the safety factor of the part. Therefore, when replacing, be sure to use parts of identical designation.
 ● Screws adjacent to \blacktriangledown mark on the product are used for disassembly.

2.1 PACKING

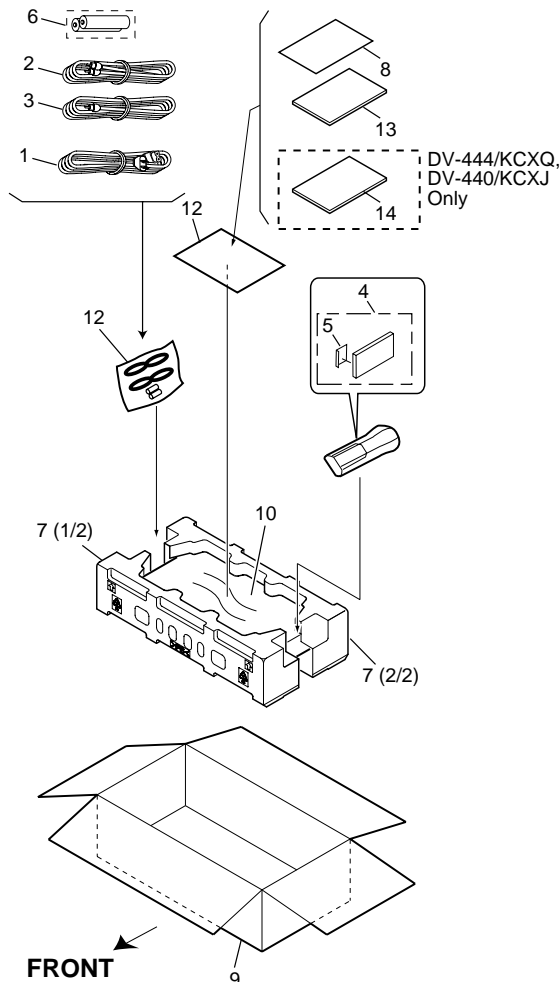

(1) PACKING PARTS LIST

Mark	No.	Description	Part No.
Δ	1	Power Cord	ADG7022
	2	Audio Cord (L = 1.5m)	See Contrast table (2)
	3	Video Cord (L = 1.5m)	See Contrast table (2)
	4	Remote Control Unit	See Contrast table (2)
	5	Battery Cover	See Contrast table (2)
NSP	6	Dry Cell Battery (R6P, AA)	See Contrast table (2)
	7	Pad	VHA1285
NSP	8	Warranty Card	ARY7045
	9	Packing Case	See Contrast table (2)
	10	Mirror Mat (0.5 × 750 × 600)	Z23-007
	11	
	12	Polyethylene Bag (0.03 × 200 × 300)	VHL1051
	13	Operating Instructions	See Contrast table (2)
	14	Operating Instructions	See Contrast table (2)

(2) CONTRAST TABLE

DV-444/KUXQ, KCXQ, DV-440/KUXQ, KUXJ and KCXJ are constructed the same except for the following:

Mark	No.	Symbol and Description	Part No.					Remarks
			DV-444		DV-440			
			KUXQ	KCXQ	KUXQ	KUXJ	KCXJ	
NSP	2	Audio Cord (L = 1.5m)	VDE1054	VDE1054	VDE1054	VDE1052	VDE1052	
	3	Video Cord (L = 1.5m)	VDE1055	VDE1055	VDE1055	VDE1053	VDE1053	
	4	Remote Control Unit	VXX2703	VXX2703	VXX2702	VXX2702	VXX2702	
	5	Battery Cover	AZA7204	AZA7204	VNK4631	VNK4631	VNK4631	
	6	Dry Cell Battery (R6P, AA)	VEM1010	VEM1010	VEM1010	VEM-013	VEM-013	
	9	Packing Case	VHG2079	VHG2120	VHG2128	VHG2127	VHG2129	
	13	Operating Instructions (English)	VRB1269	VRB1269	VRB1277	VRB1277	VRB1277	
14	Operating Instructions (French)	Not used	VRC1130	Not used	Not used	VRC1144		

2.2 EXTERIOR SECTION

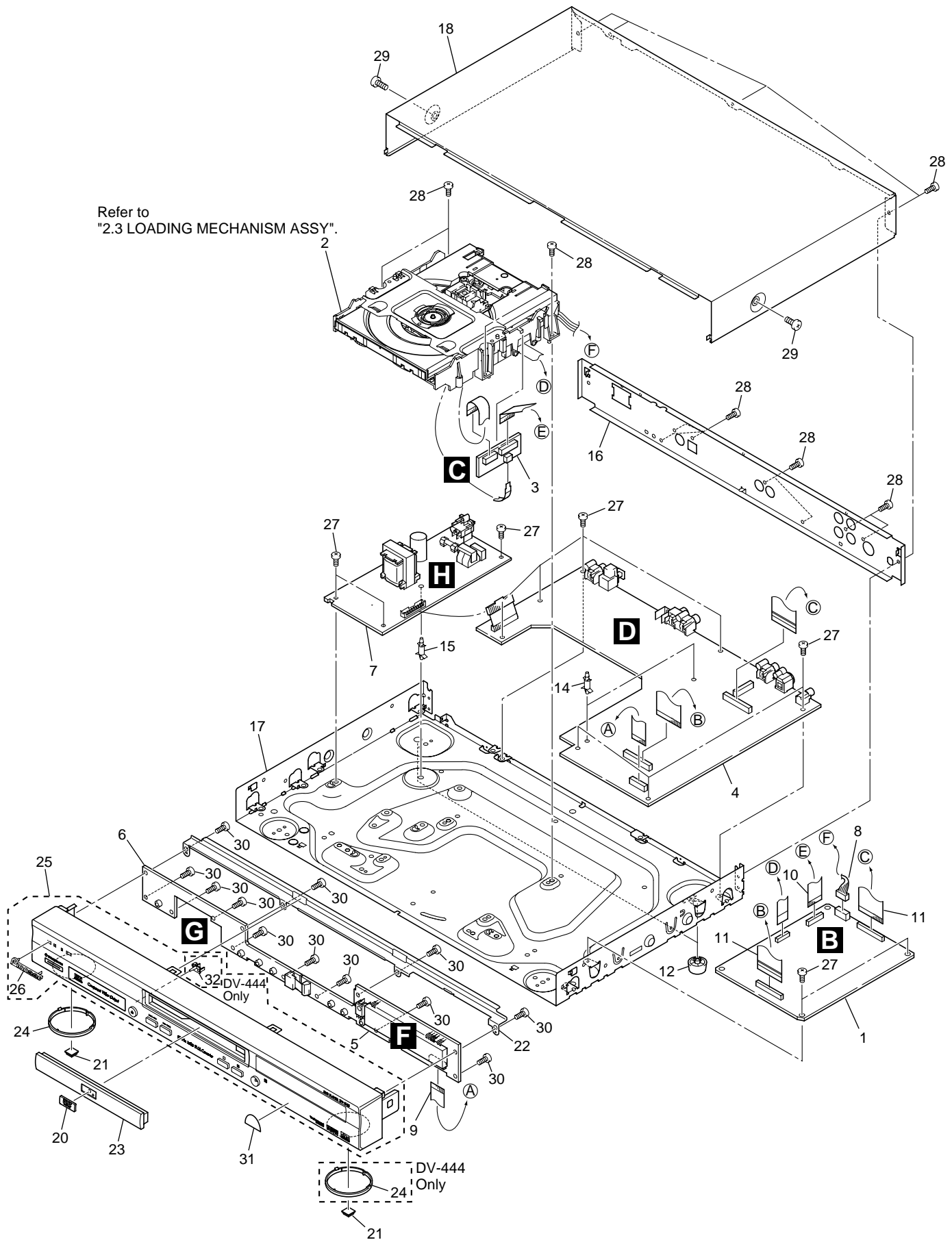

(1) EXTERIOR SECTION PARTS LIST

Mark	No.	Description	Part No.	Mark	No.	Description	Part No.
	1	DVDM Assy	See Contrast table (2)		16	Rear Panel	See Contrast table (2)
NSP	2	Loading Mechanism Assy	VWT1188	NSP	17	Base Chassis	VNA2300
NSP	3	SSIB Assy	VWG2292		18	Bonnet	See Contrast table (2)
	4	JACB Assy	See Contrast table (2)		19	•••••	
NSP	5	FLKB Assy	See Contrast table (2)		20	DVD-V Plate	VAM1121
NSP	6	KEYB Assy	See Contrast table (2)		21	Rubber Foot	VEB1325
△	7	POWER SUPPLY Unit	VWR1339		22	FP Angle	VNE2250
	8	Flexible Cable (16P)	See Contrast table (2)		23	Tray Panel	See Contrast table (2)
	9	Flexible Cable (17P)	See Contrast table (2)		24	Ring	See Contrast table (2)
	10	Flexible Cable (30P)	See Contrast table (2)		25	Front Panel Assy	See Contrast table (2)
	11	Leg Assy SX	AEC7113		26	Pioneer Name Plate	See Contrast table (2)
	12	Connector Assy	PG05KK-E30		27	Screw	BBZ30P060FMC
	13	•••••			28	Screw	BBZ30P080FZK
NSP	14	PCB Support	REC1285		29	Screw	See Contrast table (2)
	15	PCB Support	VEC2184		30	Screw	BBZ30P100FZK
				NSP	31	Energy Star Label	AAX7876
					32	LED Lens	See Contrast table (2)

(2) CONTRAST TABLE

DV-444/KUXQ, KCXQ, DV-440/KUXQ, KUXJ and KCXJ are constructed the same except for the following:

Mark	No.	Symbol and Description	Part No.					Remarks
			DV-444		DV-440			
			KUXQ	KCXQ	KUXQ	KUXJ	KCXJ	
	1	DVDM Assy	VWS1485		VWS1487	VWS1487		
	4	JACB Assy	VWV1840		VWV1899	VWV1844		
	5	FLKB Assy	VWG2280		VWG2332	VWG2332		
	6	KEYB Assy	VWG2289		VWG2290	VWG2290		
	8	Flexible Cable (16P)	VDA1861		VDA1861	VDA1860		
	9	Flexible Cable (17P)	VDA1863		VDA1863	VDA1862		
	10	Flexible Cable (30P)	VDA1872		VDA1872	VDA1871		
	16	Rear Panel	VNA2303		VNA2379	VNA2378		
	18	Bonnet S	Not used		Not used	VXX2775		
	18	Bonnet	VNA2333		VNA2331	Not used		
	23	Tray Panel	VNK4837		VNK4835	VNK4835		
	24	Ring	VNK4840		Not used	Not used		
	25	Front Panel Assy	VXA2465		VXA2478	VXA2478		
	26	Pioneer Name Plate	VAM1129		VAM1109	VAM1109		
	29	Screw	BCZ40P060FNI		BCZ40P060FZK	BCZ40P060FZK		
	32	LED Lens	VNK4841		Not used	Not used		

2.3 LOADING MECHANISM ASSY

Note :



Refer to "Application of Lubricant".

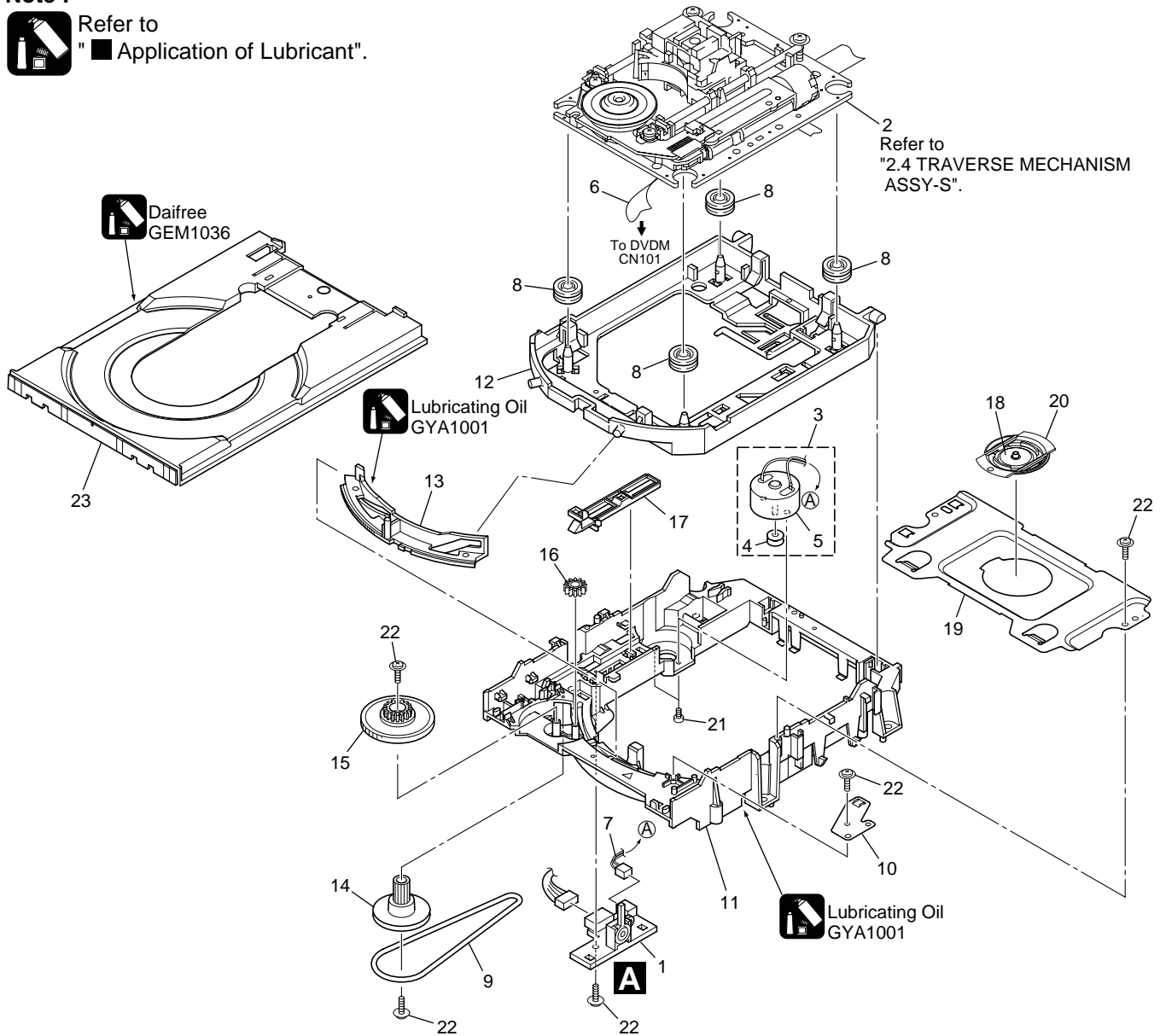

● LOADING MECHANISM ASSY PARTS LIST

Mark	No.	Description	Part No.	Mark	No.	Description	Part No.
NSP	1	LOAB Assy	VWG2279	11	11	Loading Base	VNL1917
	2	Traverse Mechanism Assy-S	VXX2782	12	12	Float Base DVD	VNL1918
	3	Loading Motor Assy	VXX2505	13	13	Drive Cam	VNL1919
	4	Motor Pulley	PNW1634	14	14	Gear Pulley	VNL1921
	5	Carriage DC Motor / 0.3W	PXM1027	15	15	Loading Gear	VNL1922
	6	Flexible Cable (26P)	VDA1864	16	16	Drive Gear	VNL1923
	7	Connector Assy 2P	VKP2253	17	17	SW Lever	VNL1925
	8	Float Rubber	VEB1327	18	18	Clamper Plate	VNE2251
	9	Belt	VEB1330	19	19	Bridge	VNE2252
	10	Stabilizer	VNE2253	20	20	Clamper	VNL1924
				21	21	Screw	JGZ17P028FMC
				22	22	Screw	Z39-019
				23	23	Tray	VNL1920

■ Application of Lubricant

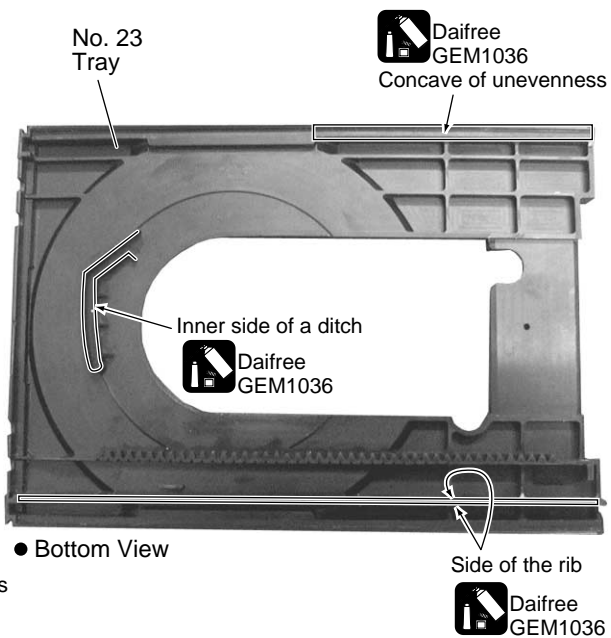
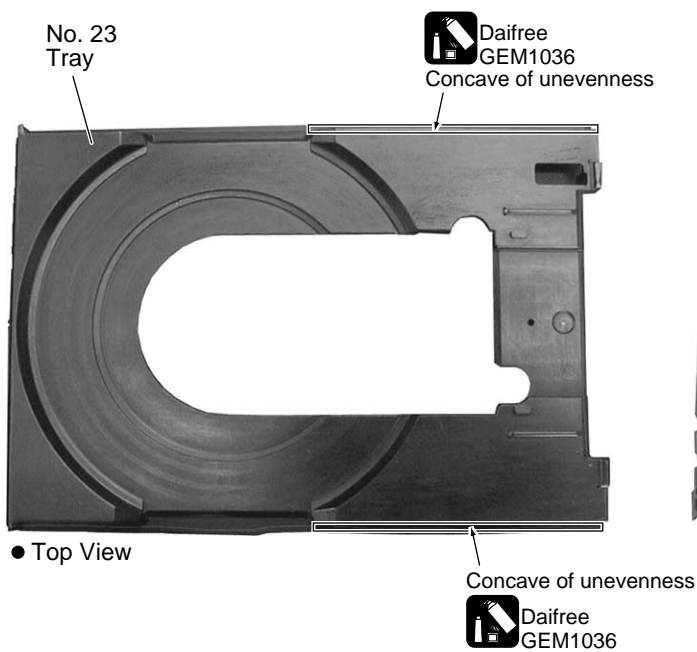
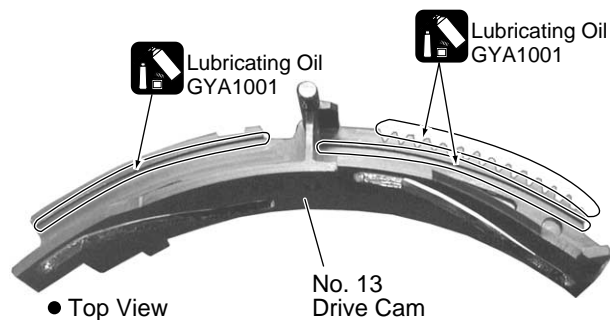
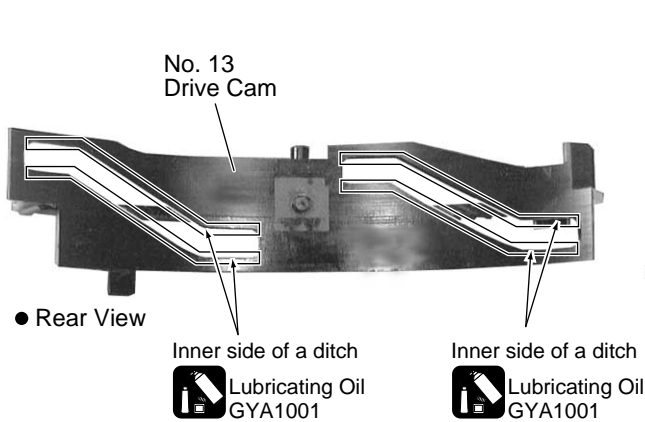
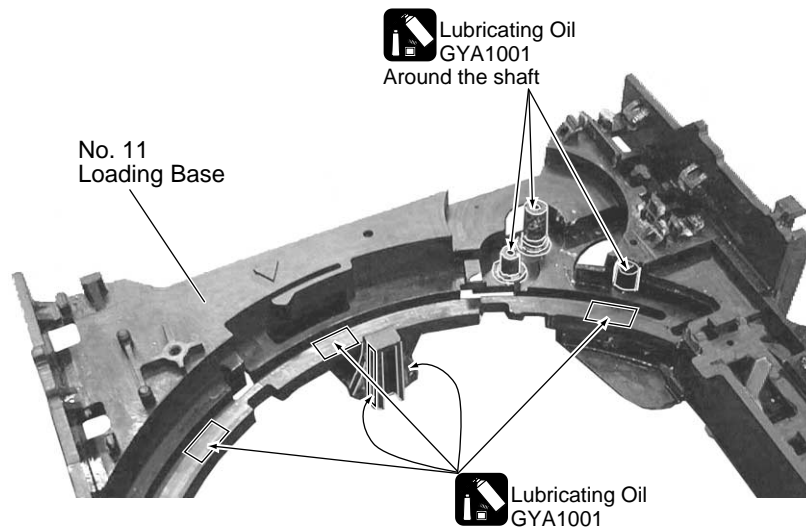

2.4 TRAVERSE MECHANISM ASSY-S

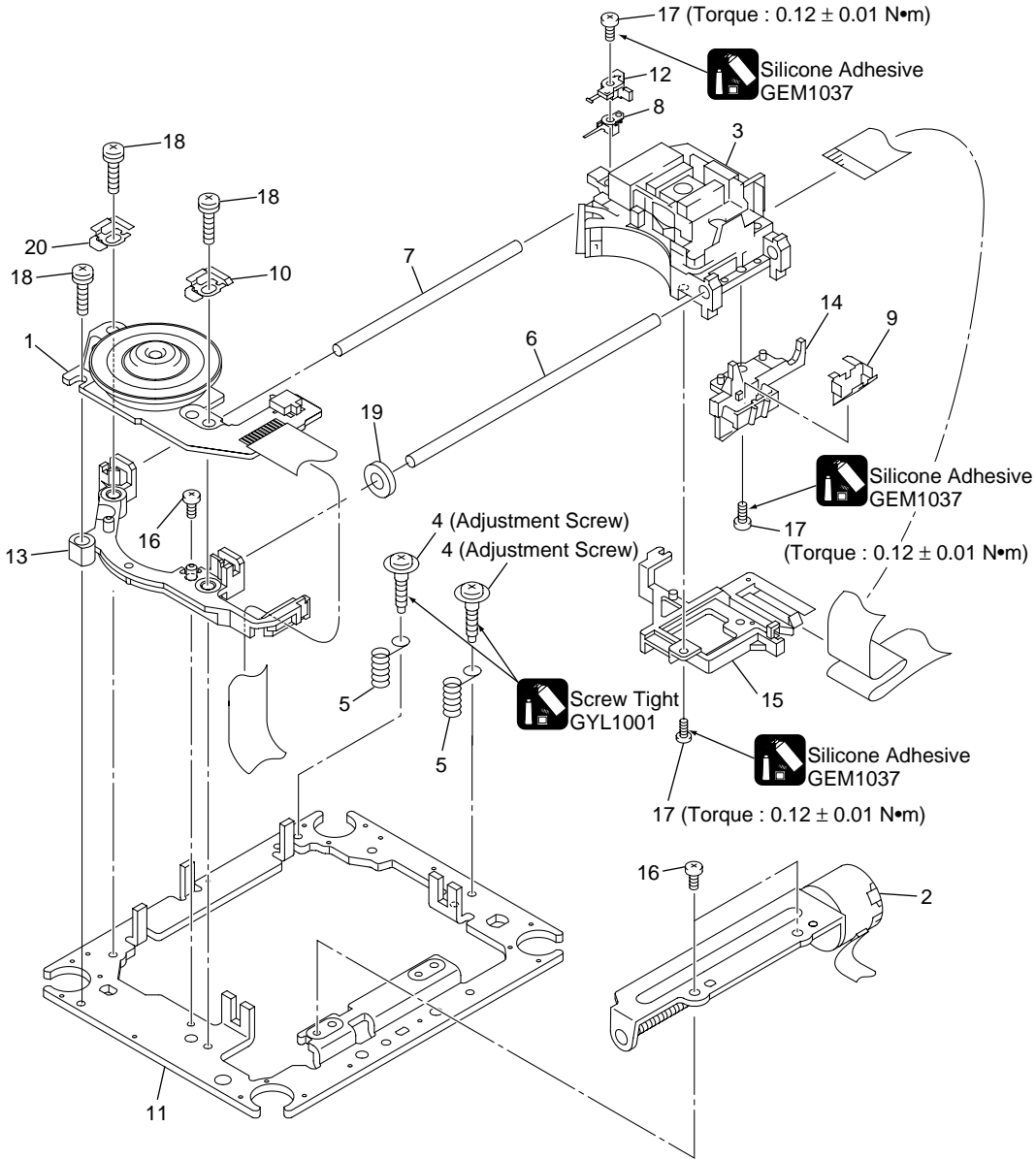

● TRAVERSE MECHANISM ASSY-S PARTS LIST

Mark	No.	Description	Part No.	Mark	No.	Description	Part No.
	1	Spindle Motor	VXM1088 (or VXM1089)	NSP	11	Mechanism Chassis	VNE2248
	2	Stepping Motor (CARRIAGE)	VXM1090 (or VXM1091)		12	Slider	VNL1811
	3	Pickup Assy-S	OXX8003		13	Spacer	VNL1913
	4	Skew Screw	VBA1080		14	Joint	VNL1914
	5	Skew Spring	VBH1335		15	FFC Holder	VNL1915
	6	Guide Bar	VLL1514		16	Screw	BBZ20P050FZK
	7	Sub Guide Bar	VLL1515		17	Screw	OBA8009
	8	Hold Spring	VNC1017		18	Screw	PMA26P100FMC
	9	Joint Spring	VNC1019		19	Damper Sheet	VEB1335
	10	Support Spring	VNC1020		20	Support Spring 2	VNC1021

3. BLOCK DIAGRAM AND SCHEMATIC DIAGRAM

3.1 BLOCK DIAGRAM

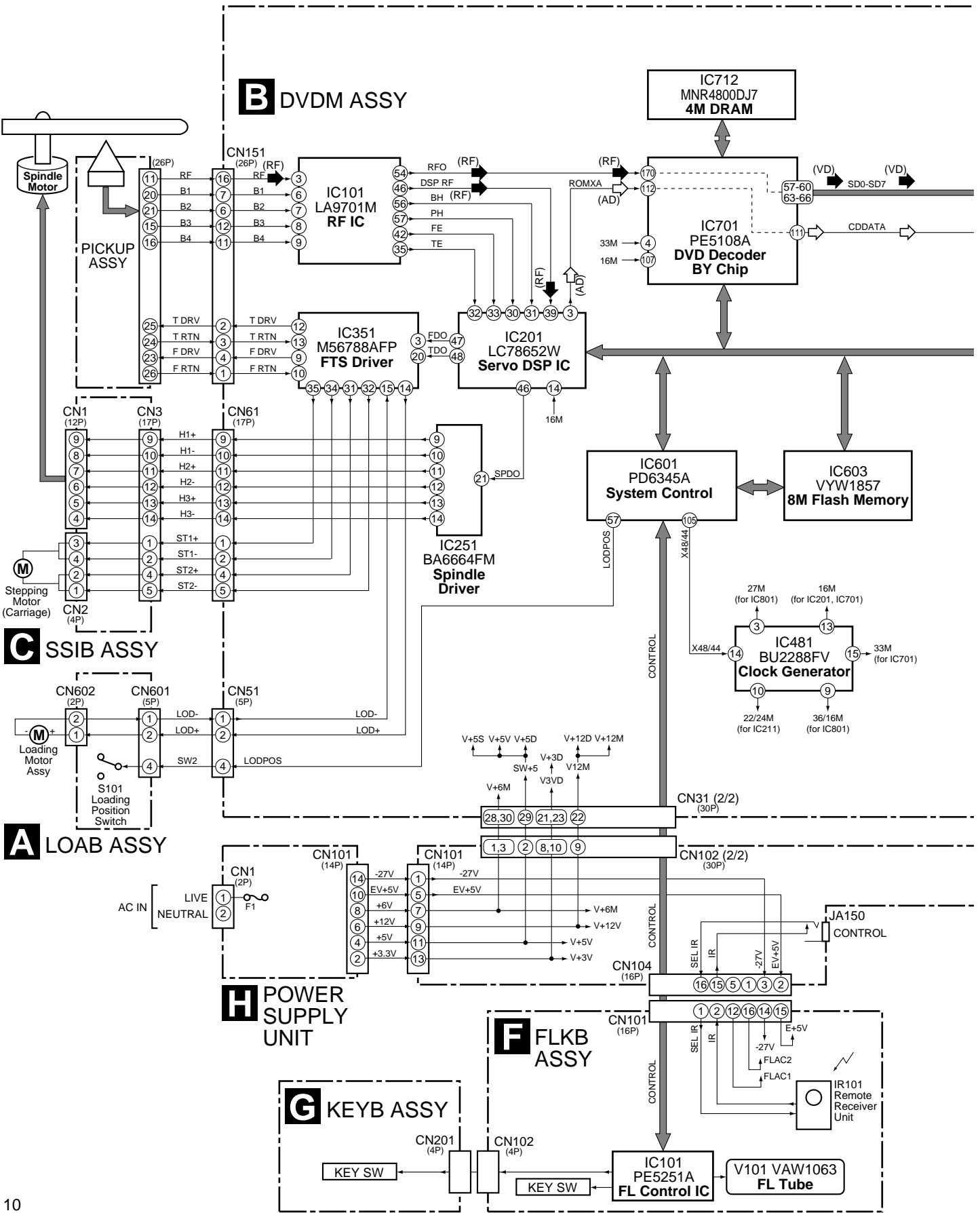

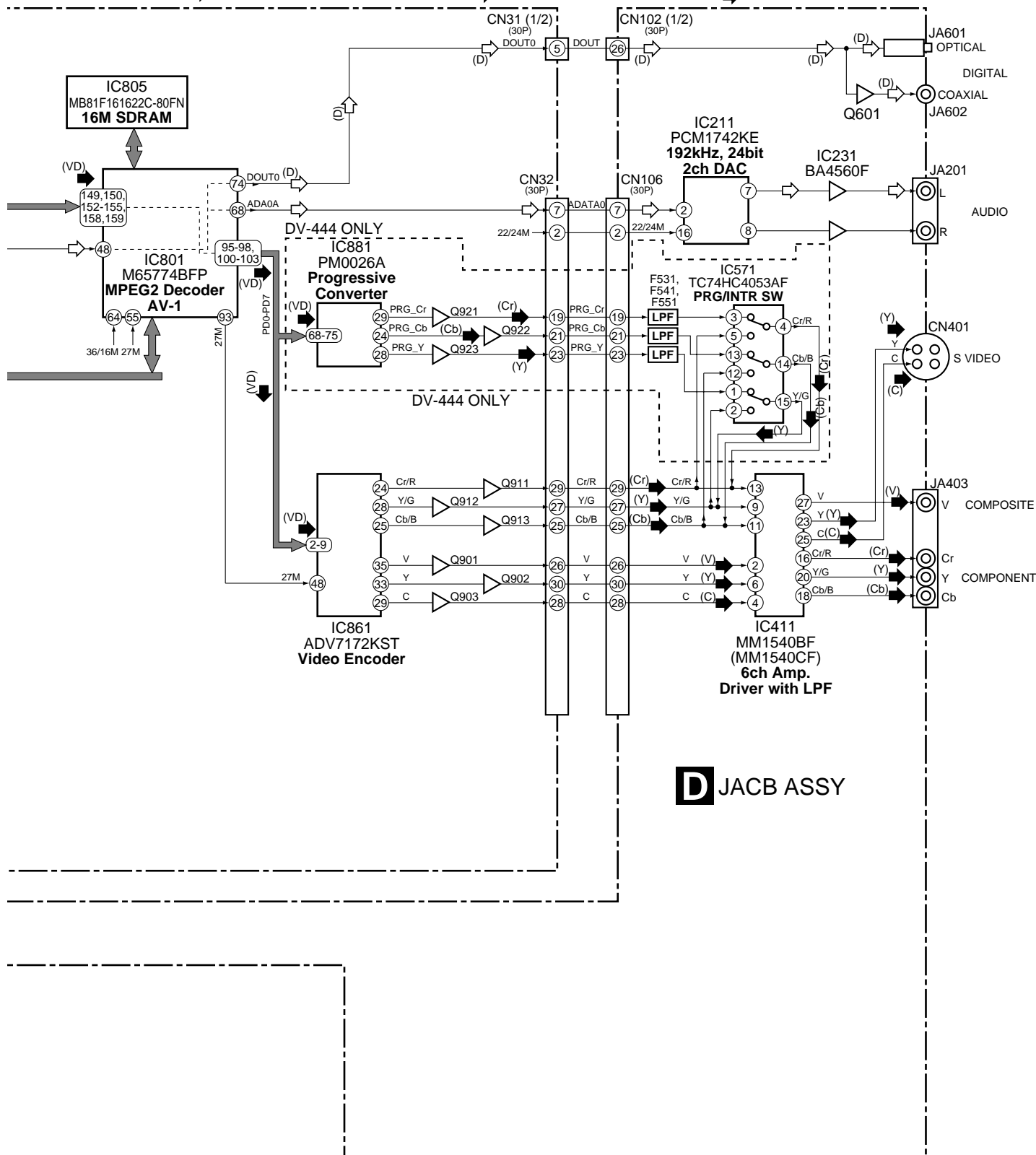
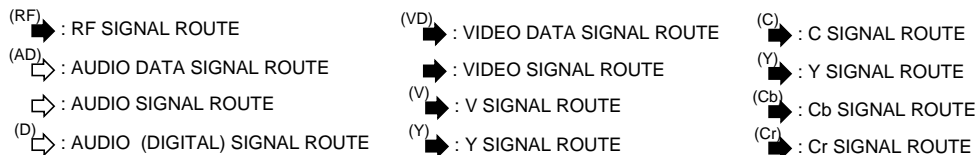

D JACB ASSY

3.2 LOAB, SSIB ASSYS and OVERALL WIRING DIAGRAM

A

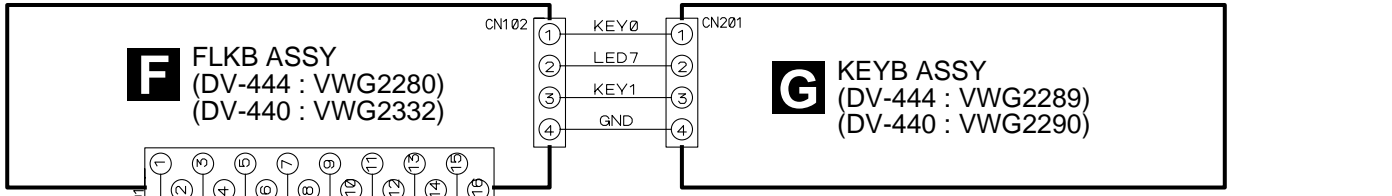

B

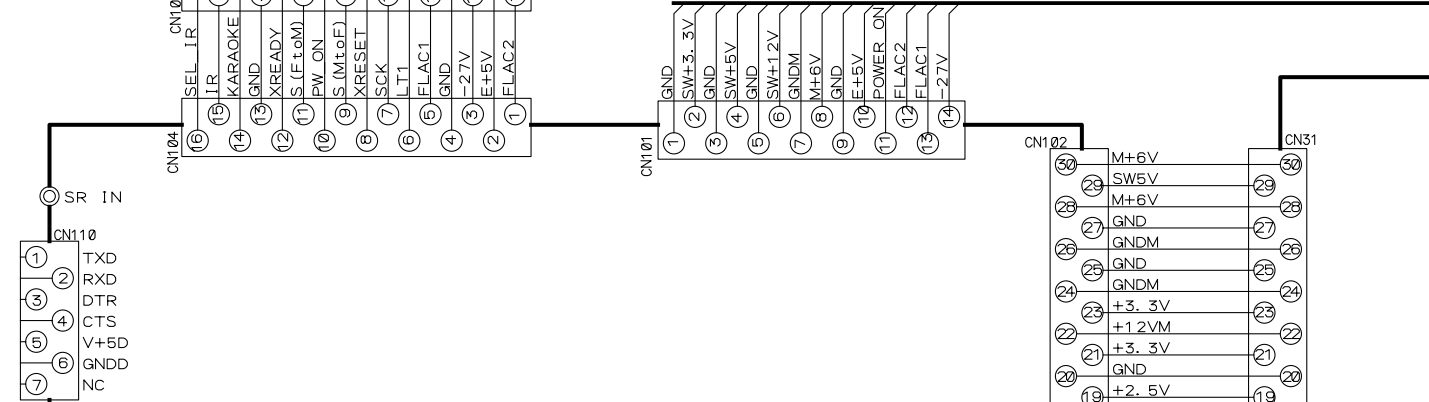

C

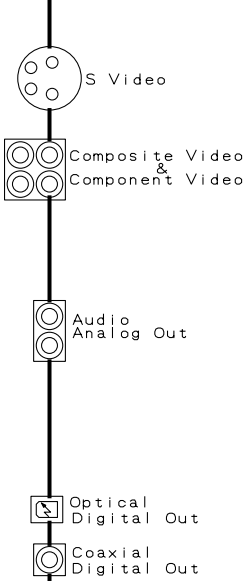

D (D 1/3-D 3/3)
JACB ASSY
 (DV-444 : VWV1840)
 (DV-440/KUXQ : VWV1899)
 (DV-440/KUXJ, KCXJ : VWV1844)

D

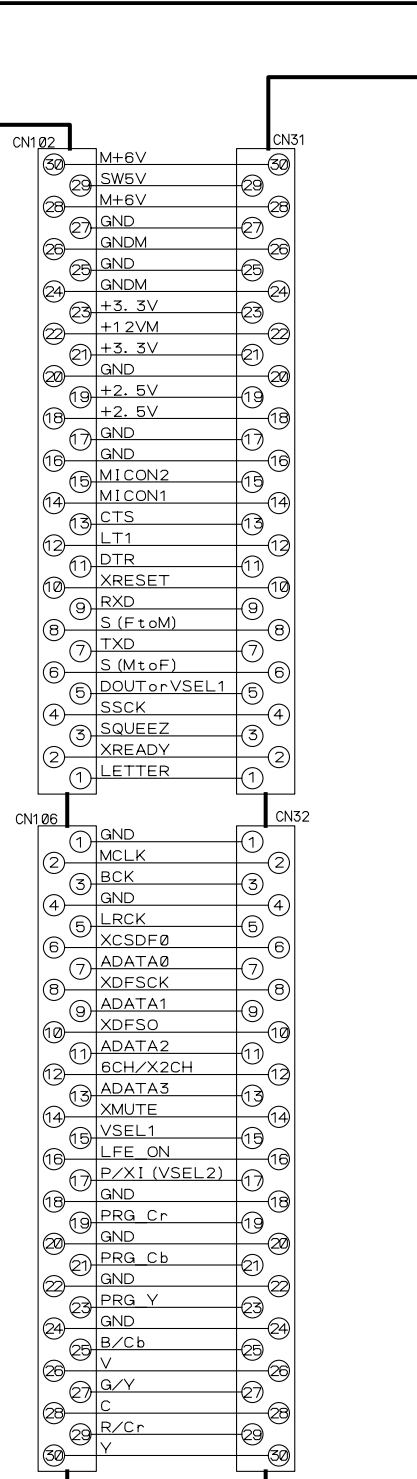

Note : When ordering service parts, be sure to refer to "EXPLODED VIEWS and PARTS LIST" or "PCB PARTS LIST".

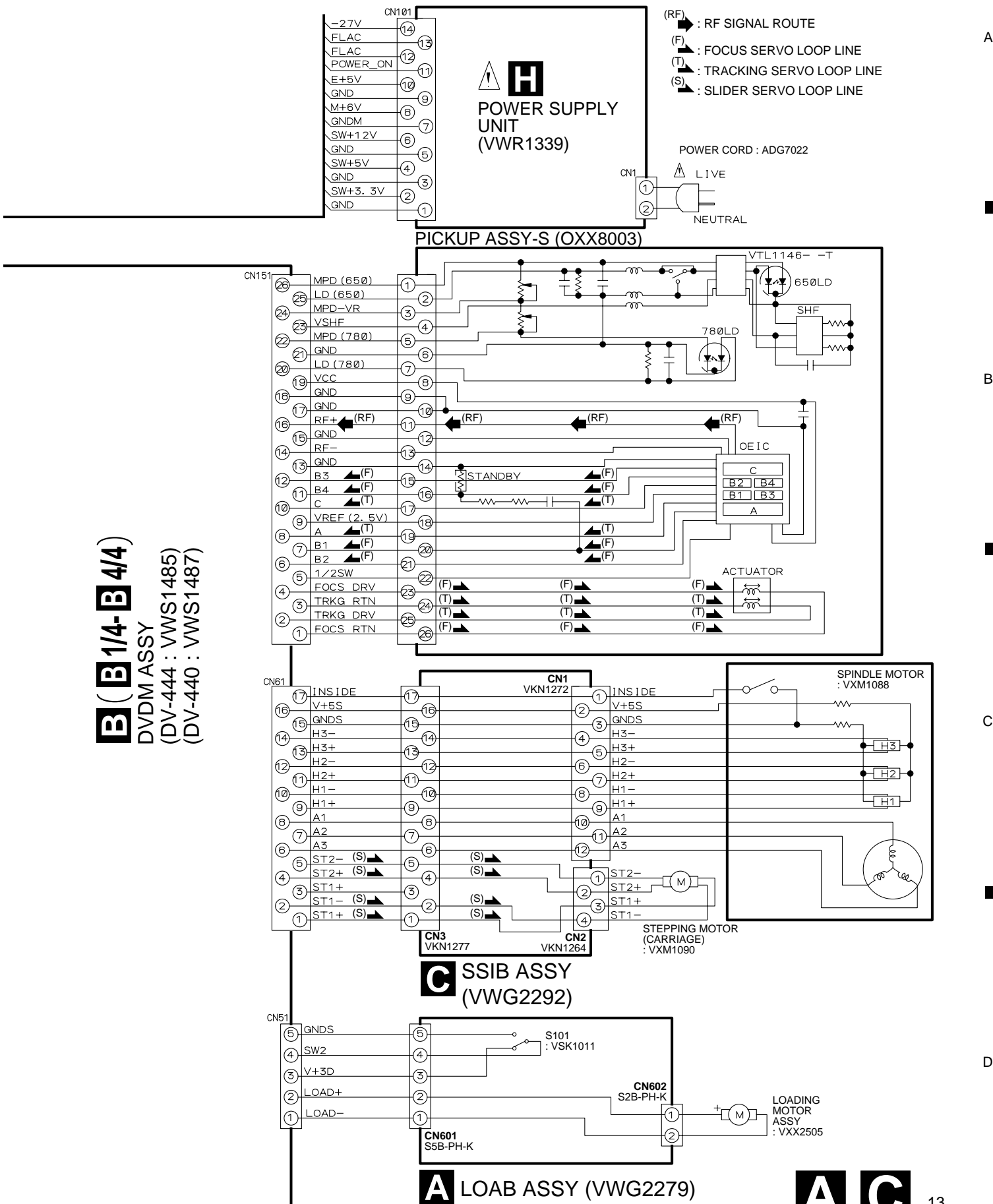

A

B

C

D

A C

3.3 DVDM ASSY (1/4)

B 1/4 DVDM ASSY (DV-444 : VWS1485)
(DV-440 : VWS1487)

A

B

C

D

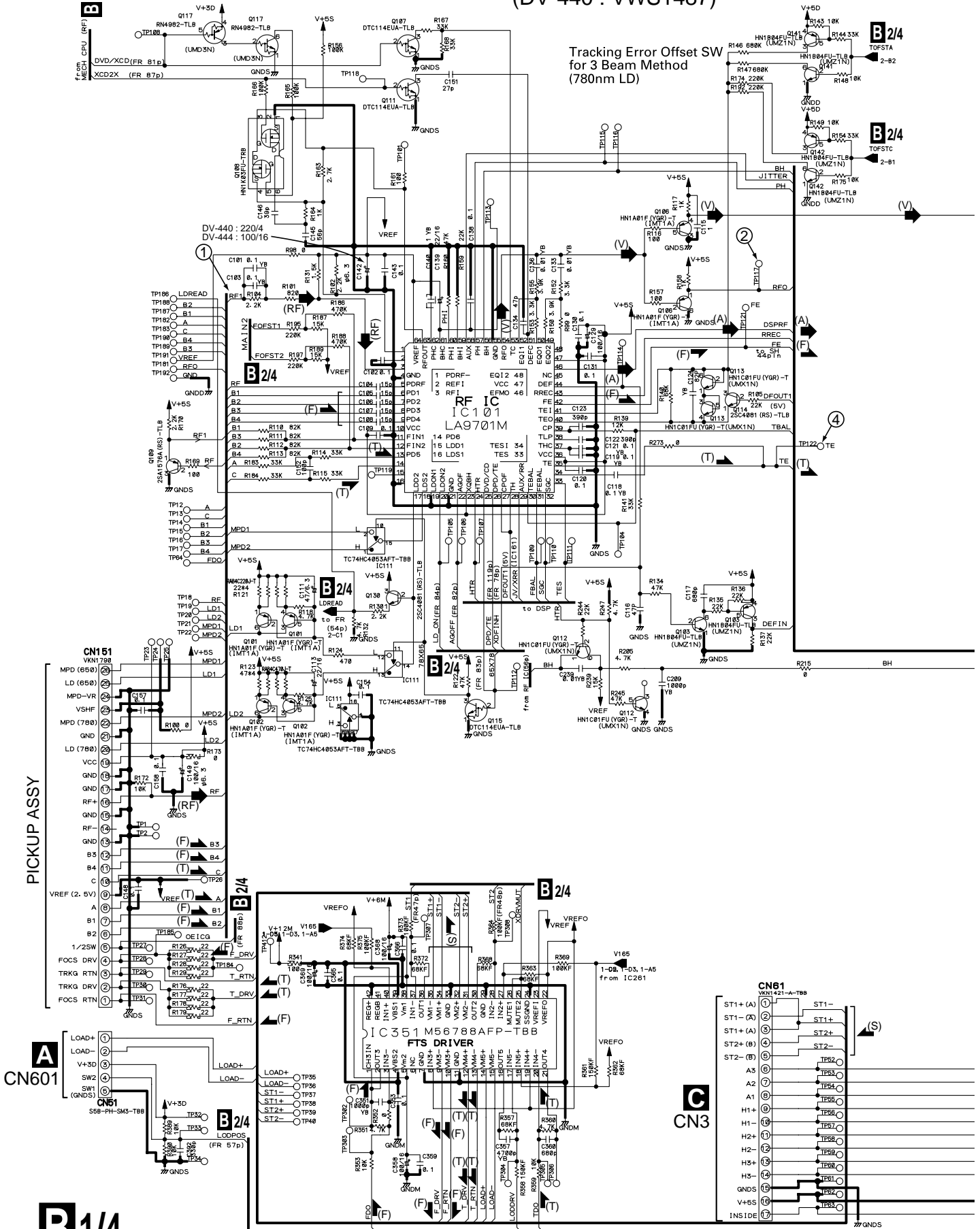

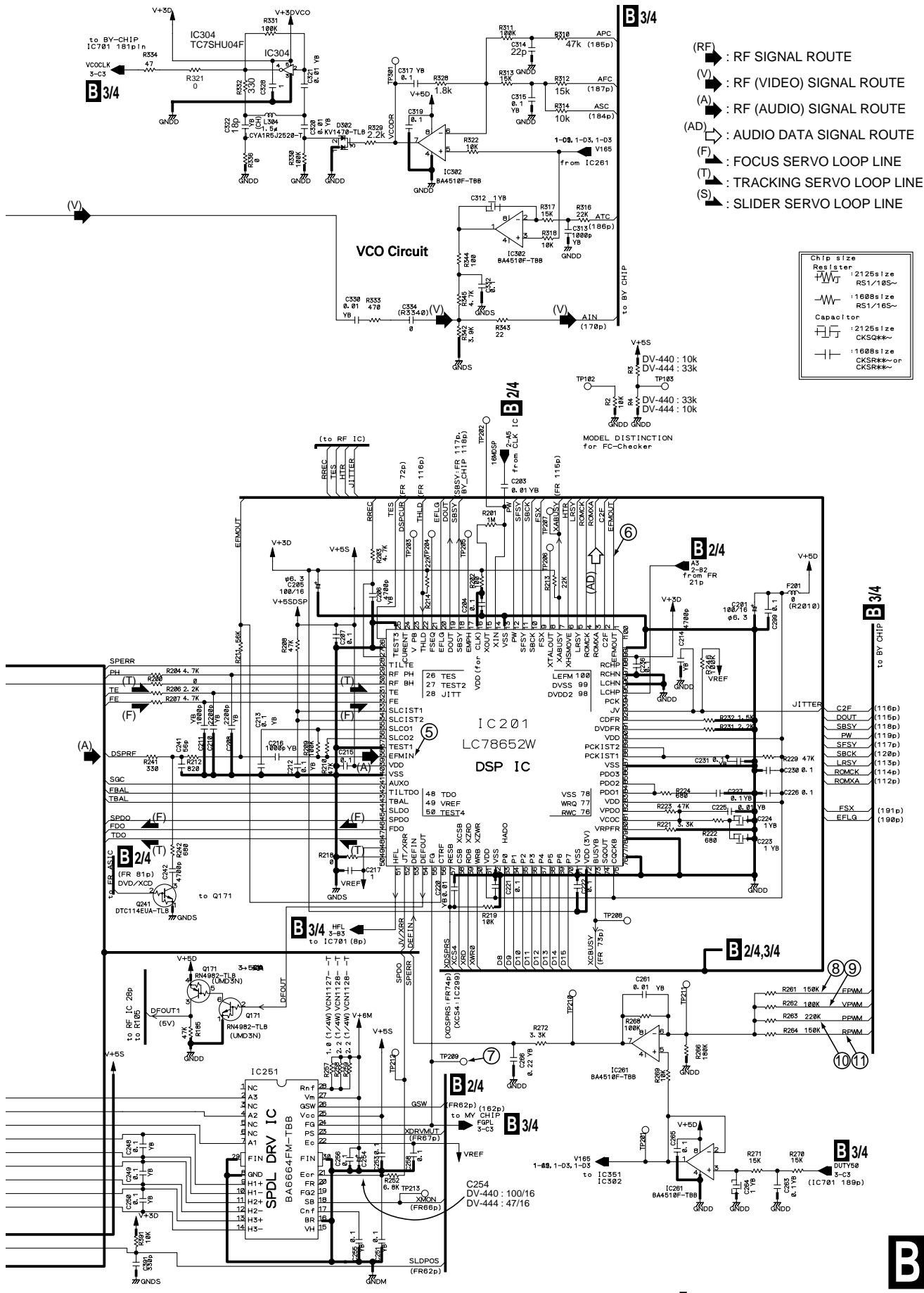

3.5 DVDM ASSY (3/4)

B 3/4 DVDM ASSY (DV-444 : VWS1485) (DV-440 : VWS1487)

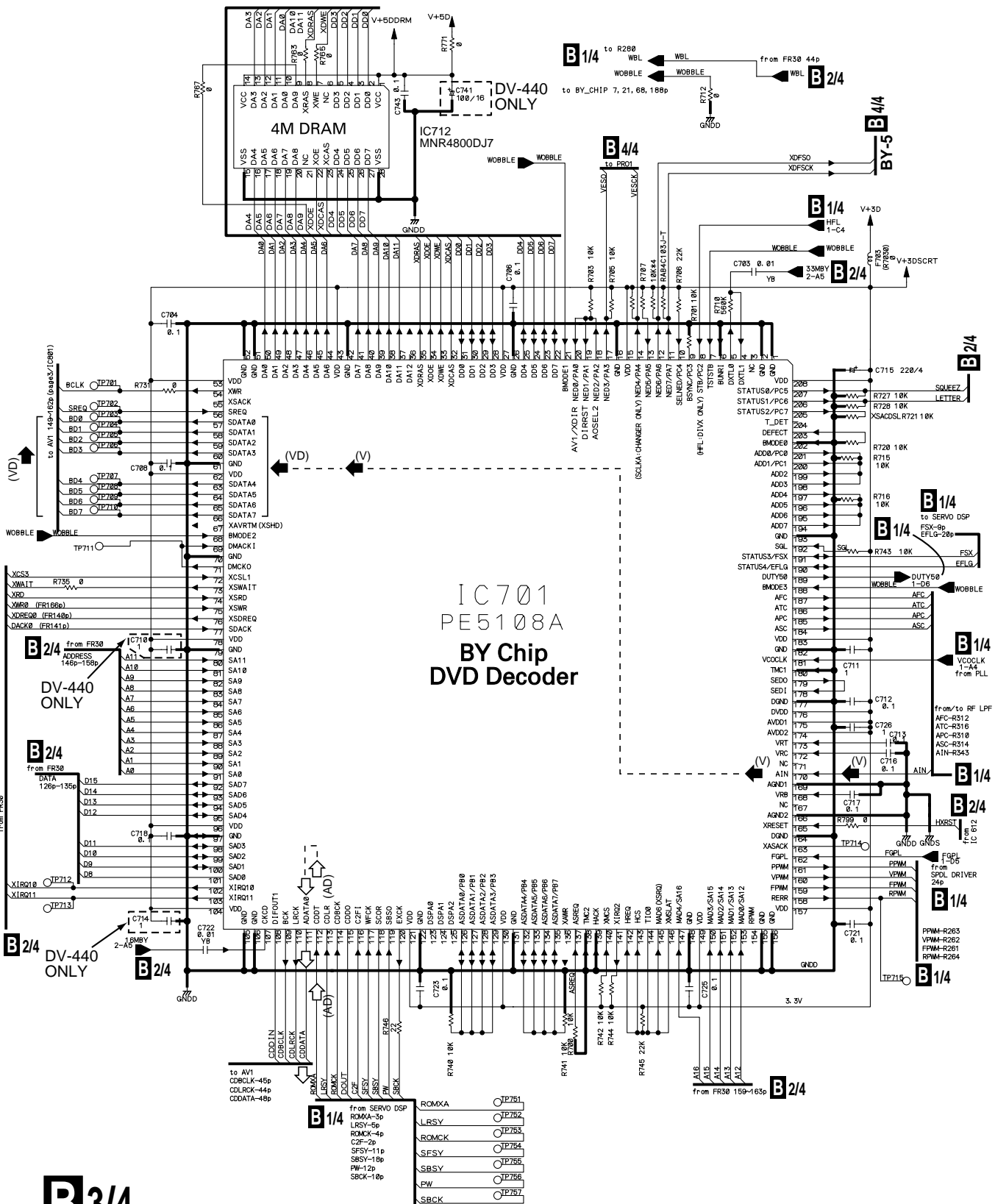

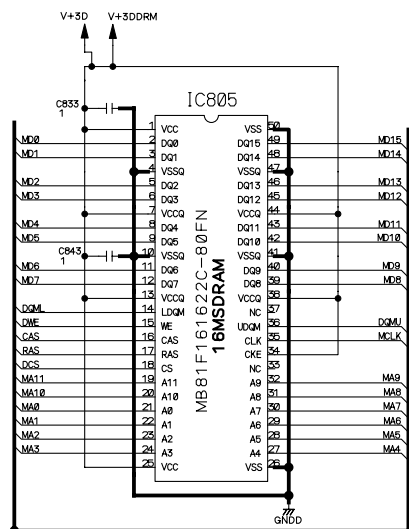

- (V) : RF (VIDEO) SIGNAL ROUTE
- (VD) : VIDEO DATA SIGNAL ROUTE
- (AD) : AUDIO DATASIGNAL ROUTE
- ▷ : AUDIO SIGNAL ROUTE
- (D) : AUDIO (DIGITAL) SIGNAL ROUTE

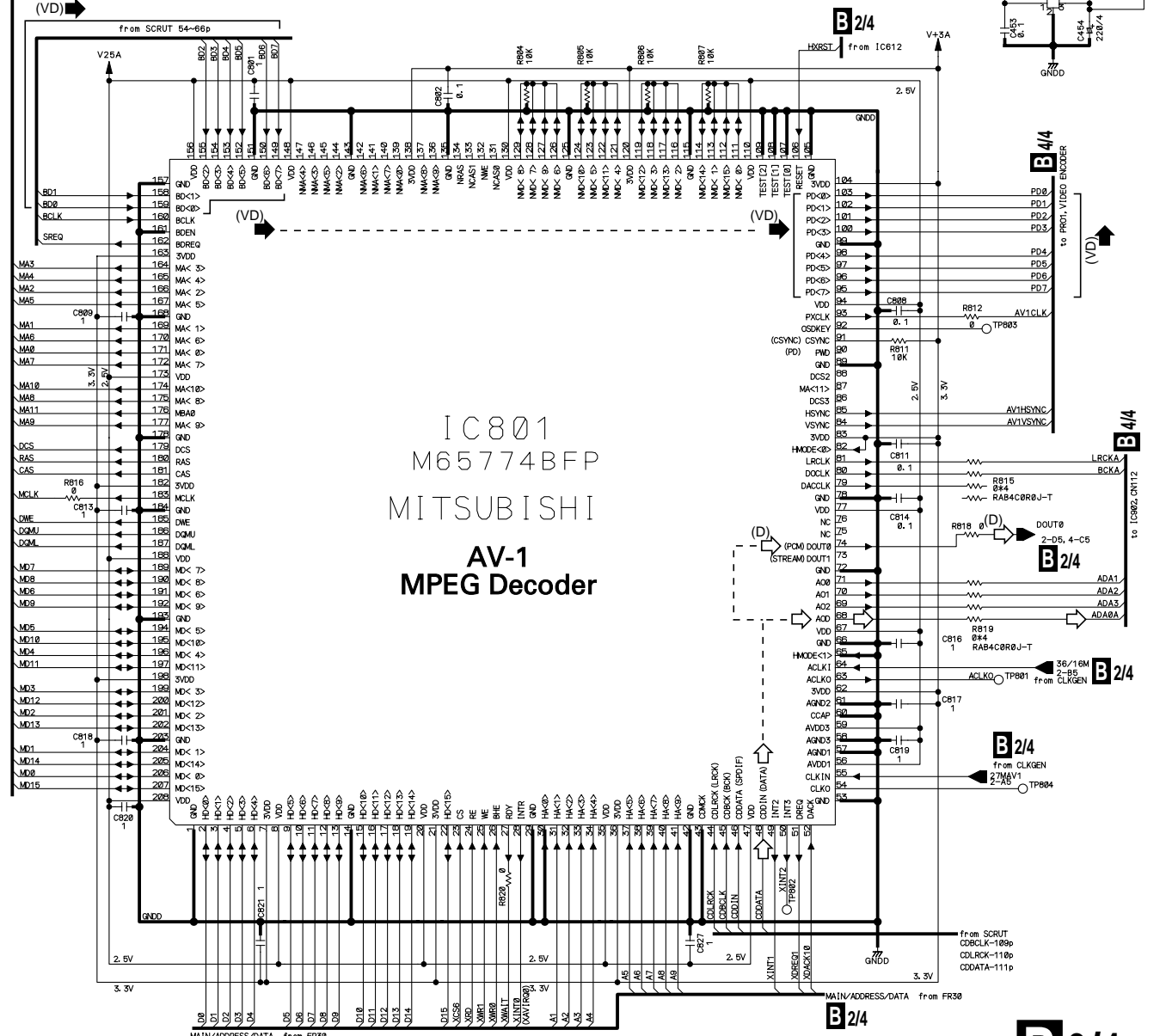
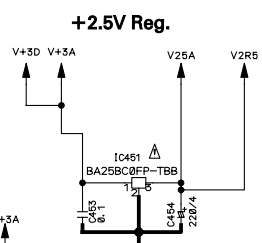
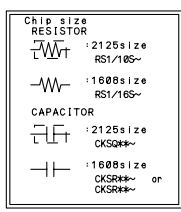

IC801
M65774BFP
MITSUBISHI
AV-1
MPEG Decoder

3.6 DVDM ASSY (4/4)

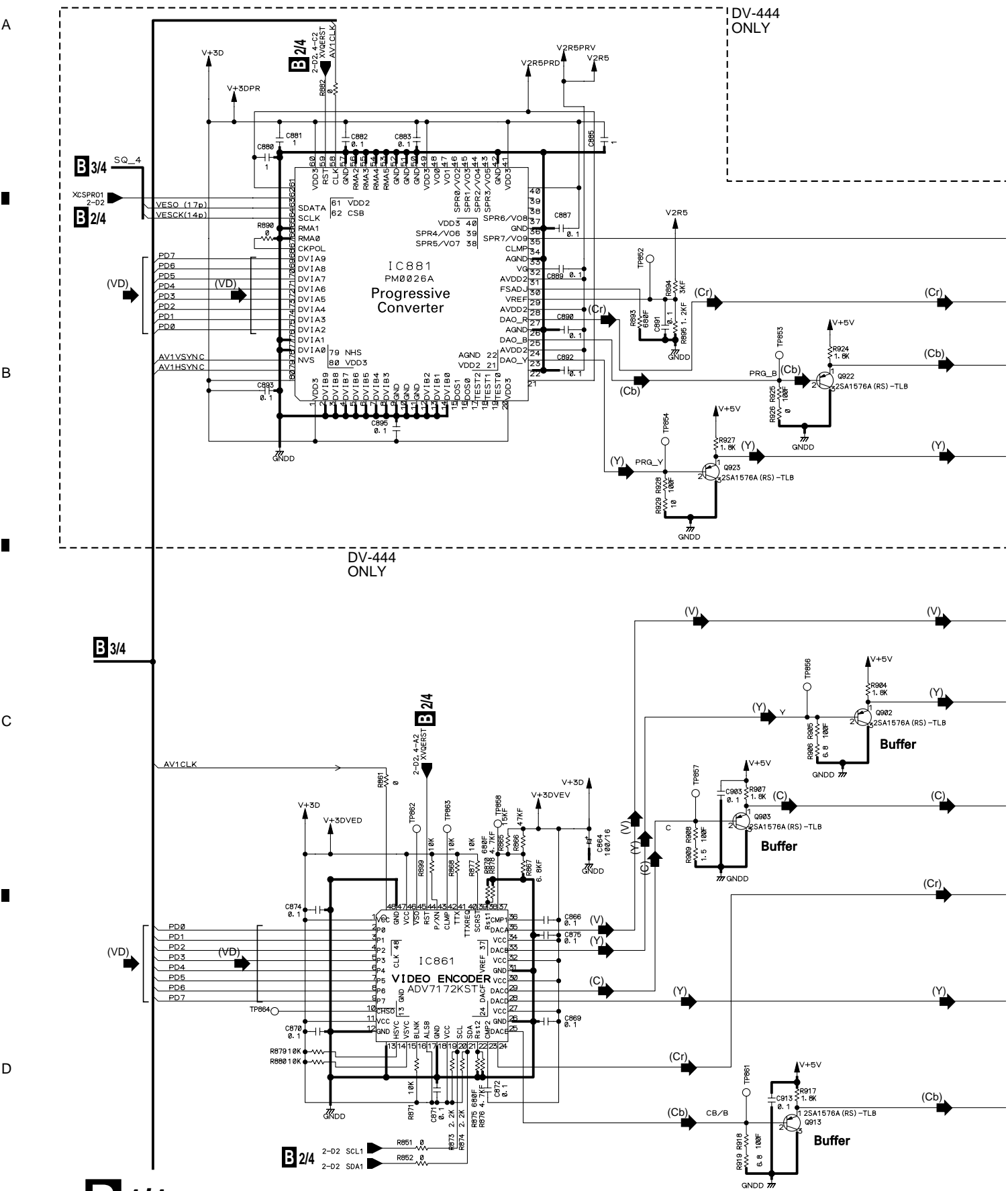

B 4/4 DVDM ASSY
 (DV-444 : VWS1485)
 (DV-440 : VWS1487)

- (VD) → VIDEO DATASIGNAL ROUTE
- (V) → V SIGNAL ROUTE
- (Y) → Y SIGNAL ROUTE
- (C) → C SIGNAL ROUTE
- (Y) → Y SIGNAL ROUTE
- (Cb) → Cb SIGNAL ROUTE
- (Cr) → Cr SIGNAL ROUTE
- ⇨ AUDIO SIGNAL ROUTE

CHIP SIZE	
RESISTOR	
	: 2125size RS1/10S~
	: 1608size RS1/16S~
CAPACITOR	
	: 2125size CKSQ**~
	: 1608size CCSR**~ or CKSR**~

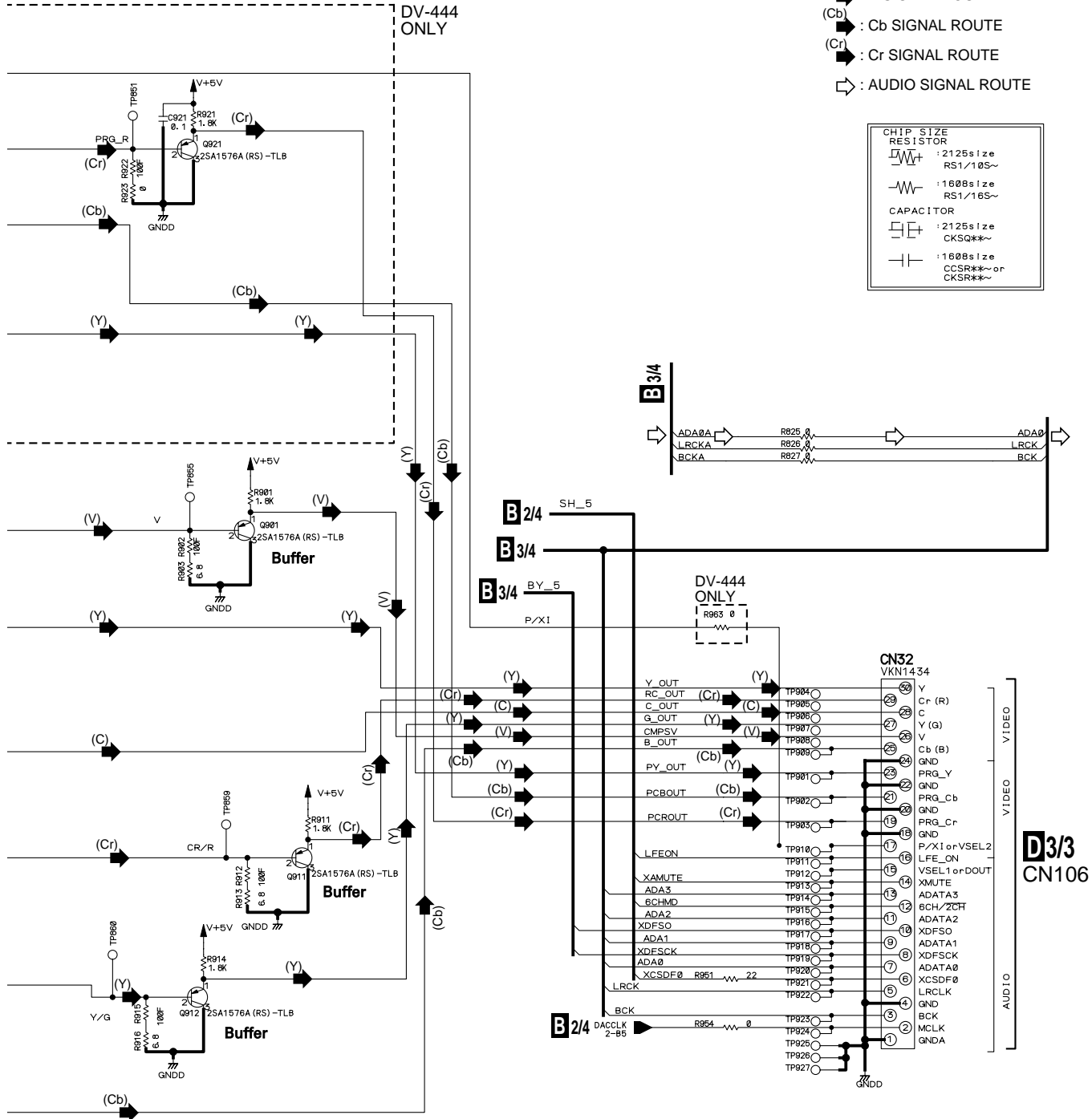

D 3/3
CN106

3.7 JACB ASSY (1/3)

D 1/3 JACB ASSY
 (DV-444 : VWV1840)
 (DV-440/KUXQ : VWV1899)
 (DV-440/KUXJ, KCXJ : VWV1844)

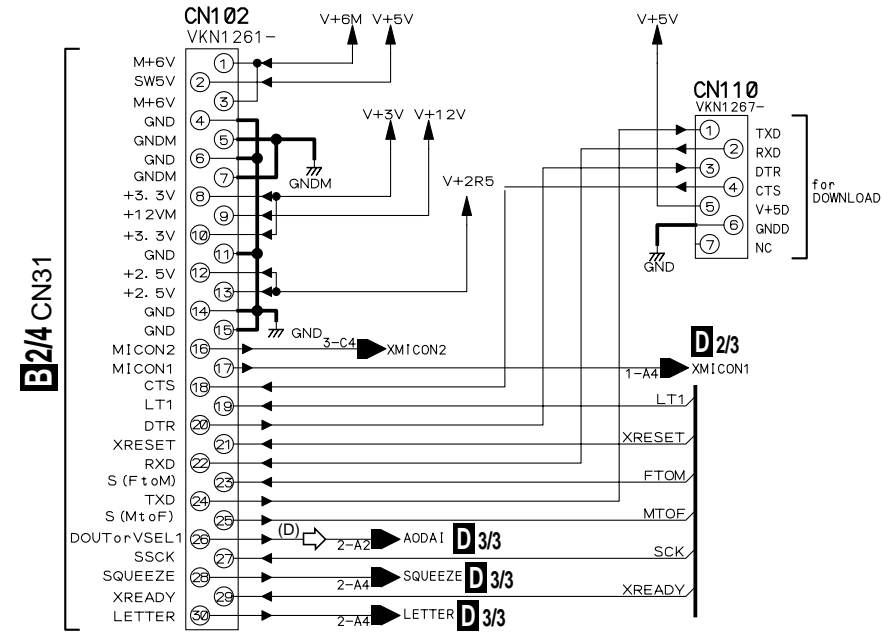
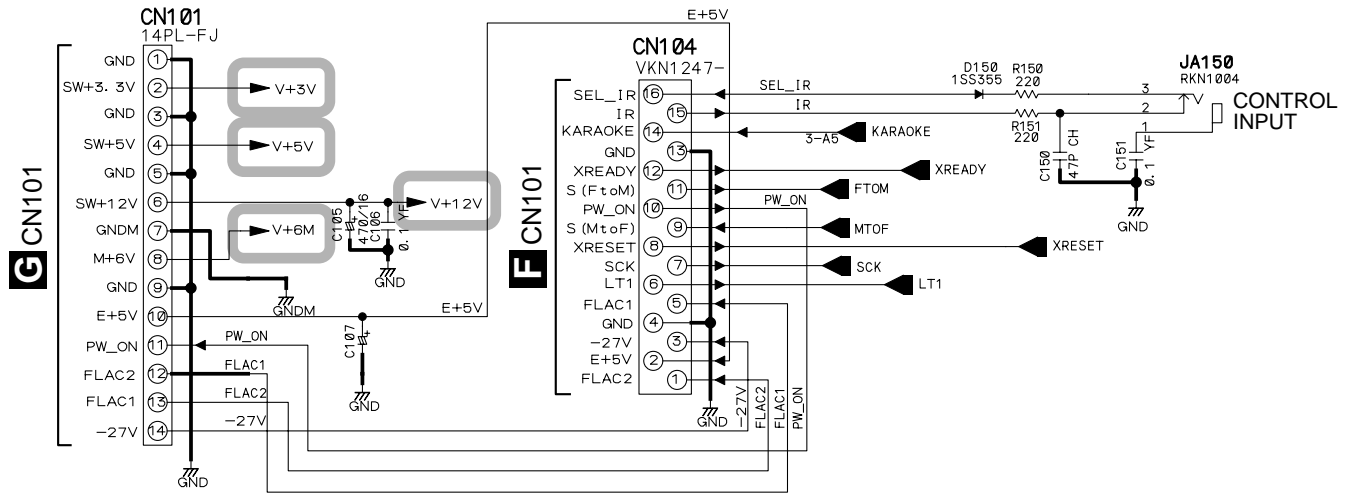

(D) : AUDIO (DIGITAL) SIGNAL ROUTE

: The power supply is shown with the marked box.

3.8 JACB ASSY (2/3)

D 2/3 JACB ASSY
 (DV-444 : VWV1840)
 (DV-440/KUXQ : VWV1899)
 (DV-440/KUXJ, KCXJ : VWV1844)

A

B

C

D

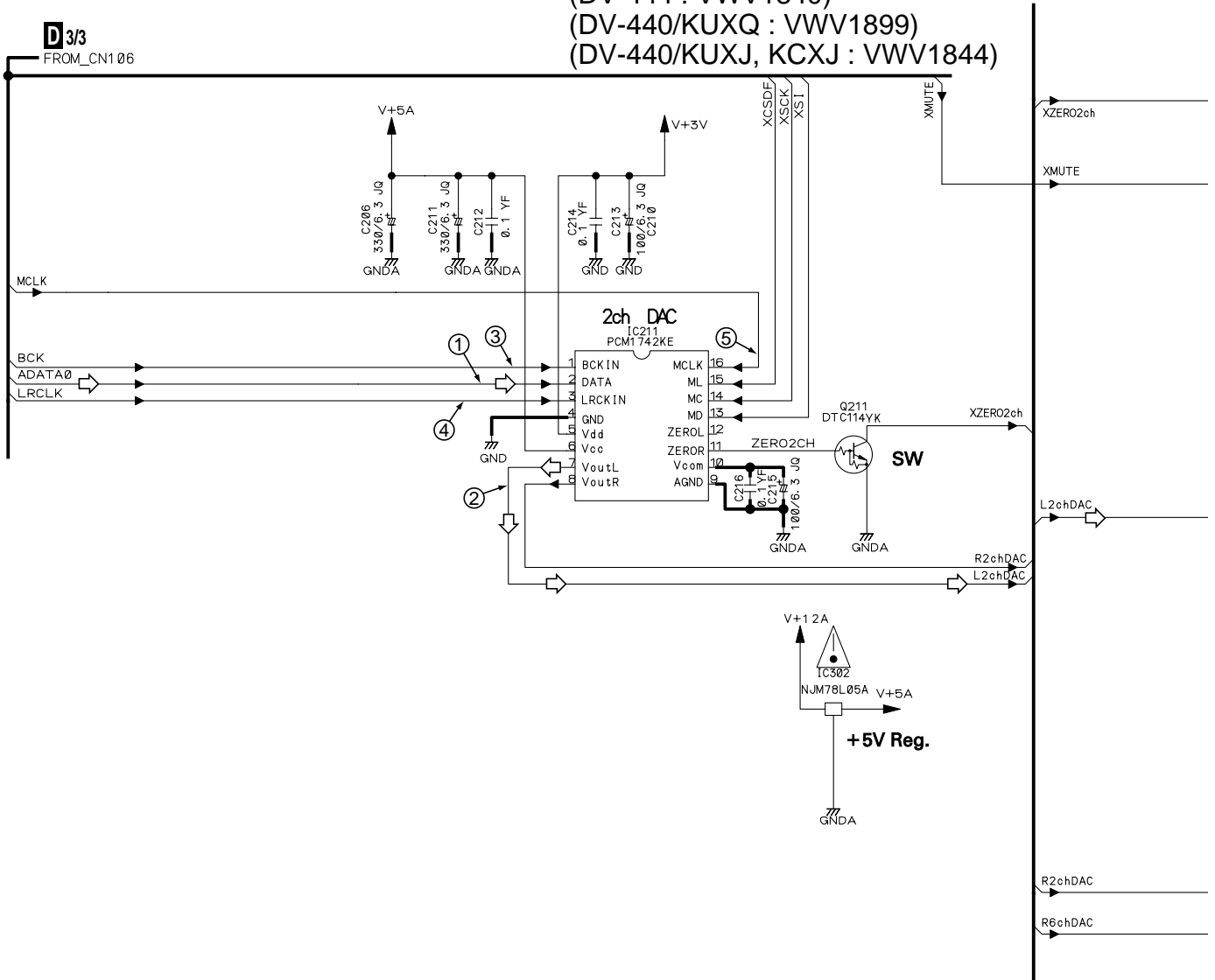

⇒ : AUDIO SIGNAL ROUTE

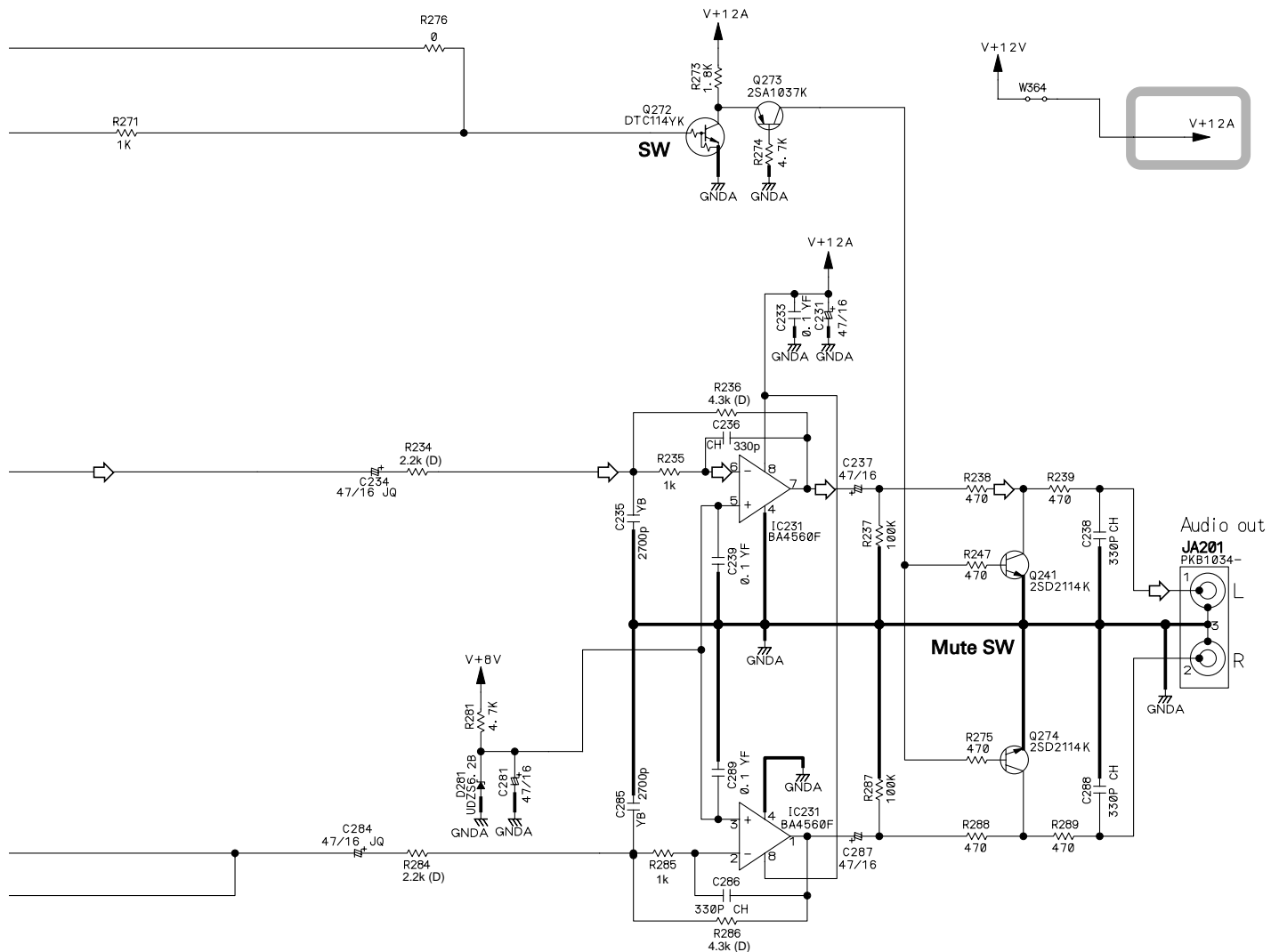

Audio Amp. (including LPF)

◻ : The power supply is shown with the marked box.

D 3/3 JACB ASSY

(DV-444 : VVW1840)
(DV-440/KUXQ : VVW1899)
(DV-440/KUXJ, KCXJ : VVW1844)

3.9 JACB ASSY (3/3)

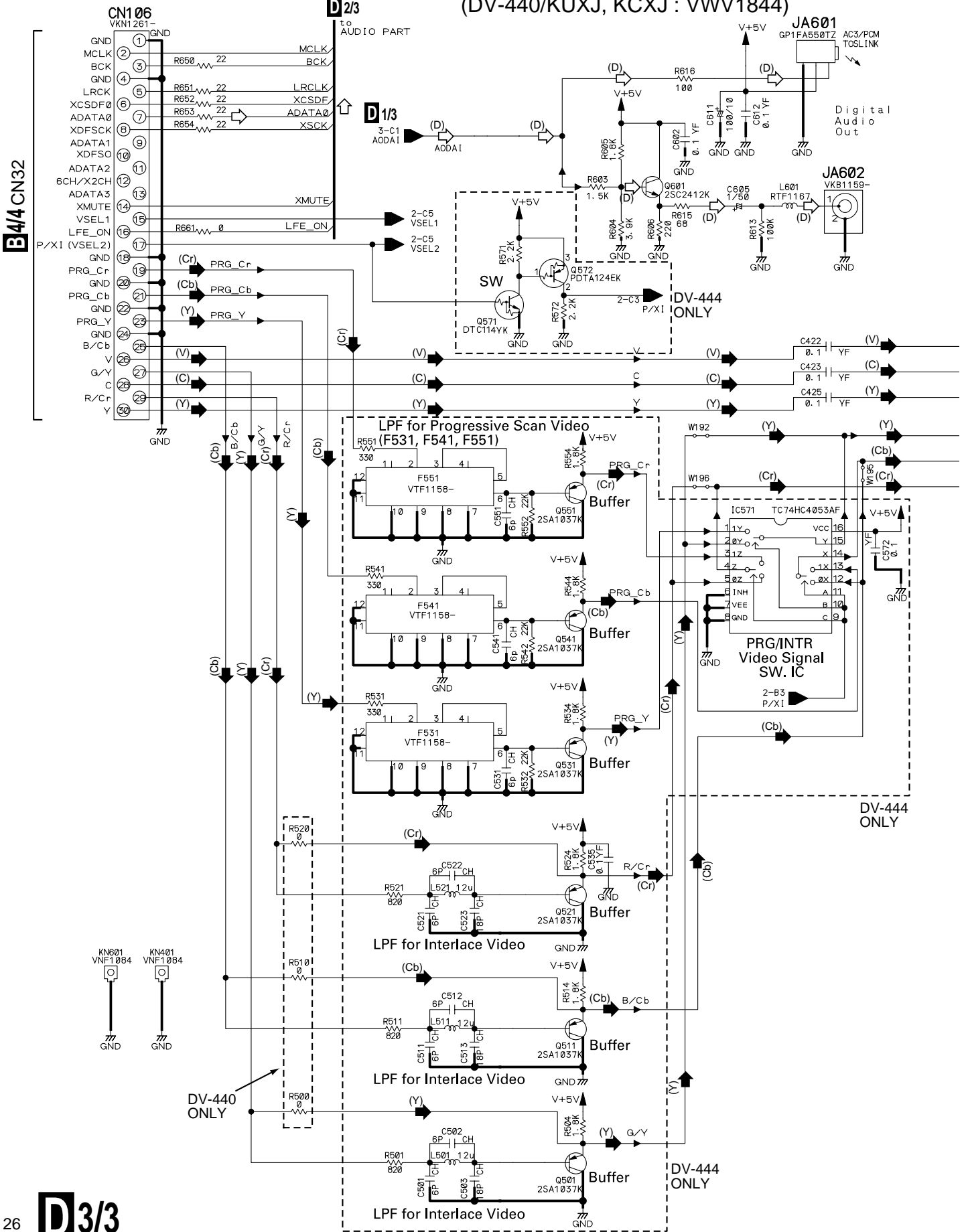

 : The power supply is shown with the marked box.

- (V) : V SIGNAL ROUTE
- (Y) : Y SIGNAL ROUTE
- (C) : C SIGNAL ROUTE
- (D) : AUDIO (DIGITAL) SIGNAL ROUTE
- (Y) : Y SIGNAL ROUTE
- (Cb) : Cb SIGNAL ROUTE
- (Cr) : Cr SIGNAL ROUTE
- ◻ : AUDIO SIGNAL ROUTE

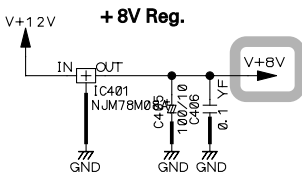
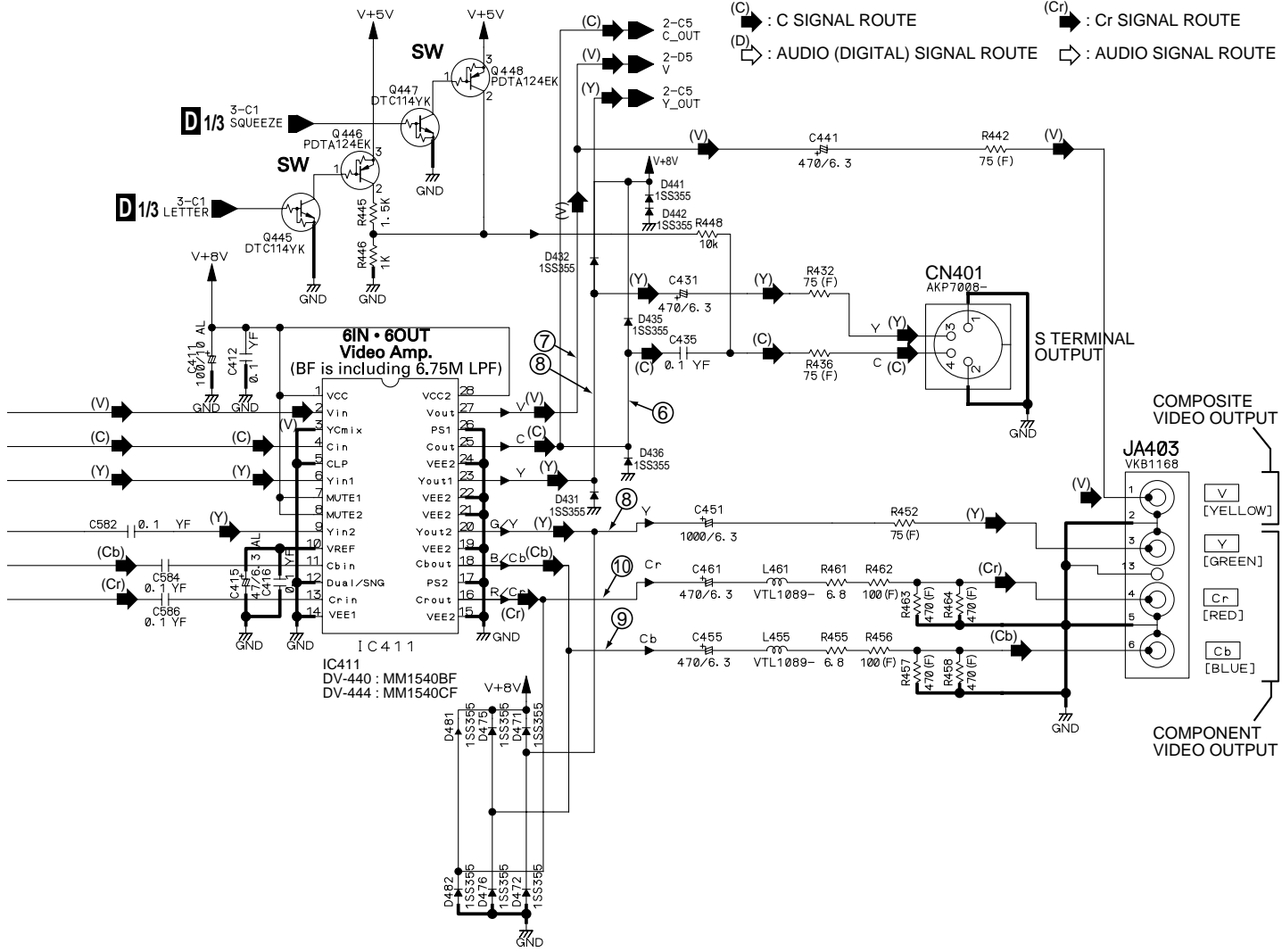

3.10 FLKB and KEYB ASSYS

F FLKB ASSY
 (DV-444 : VWG2280)
 (DV-440 : VWG2332)

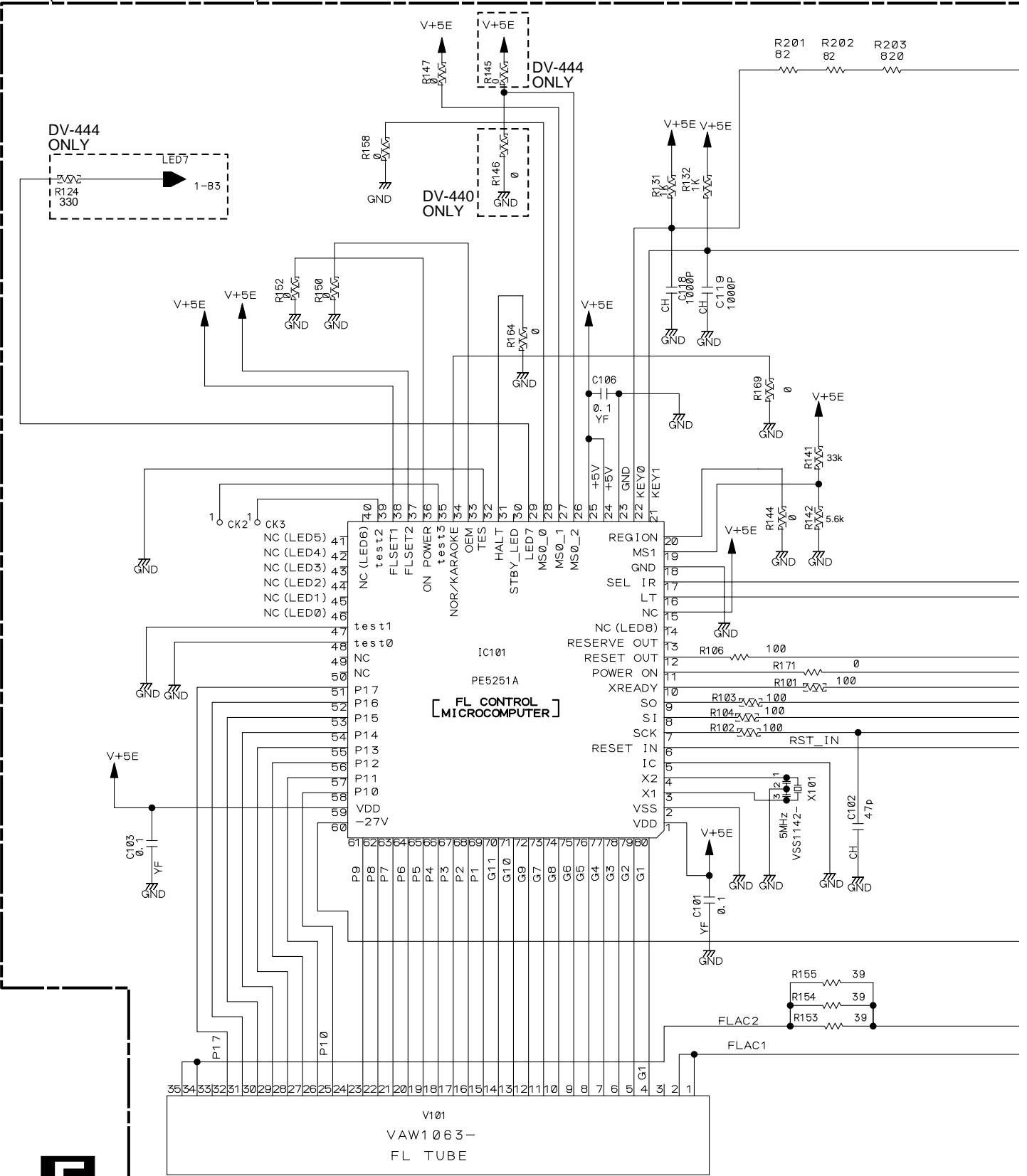

G KEYB ASSY (DV-444 : VWG2289)
(DV-440 : VWG2390)

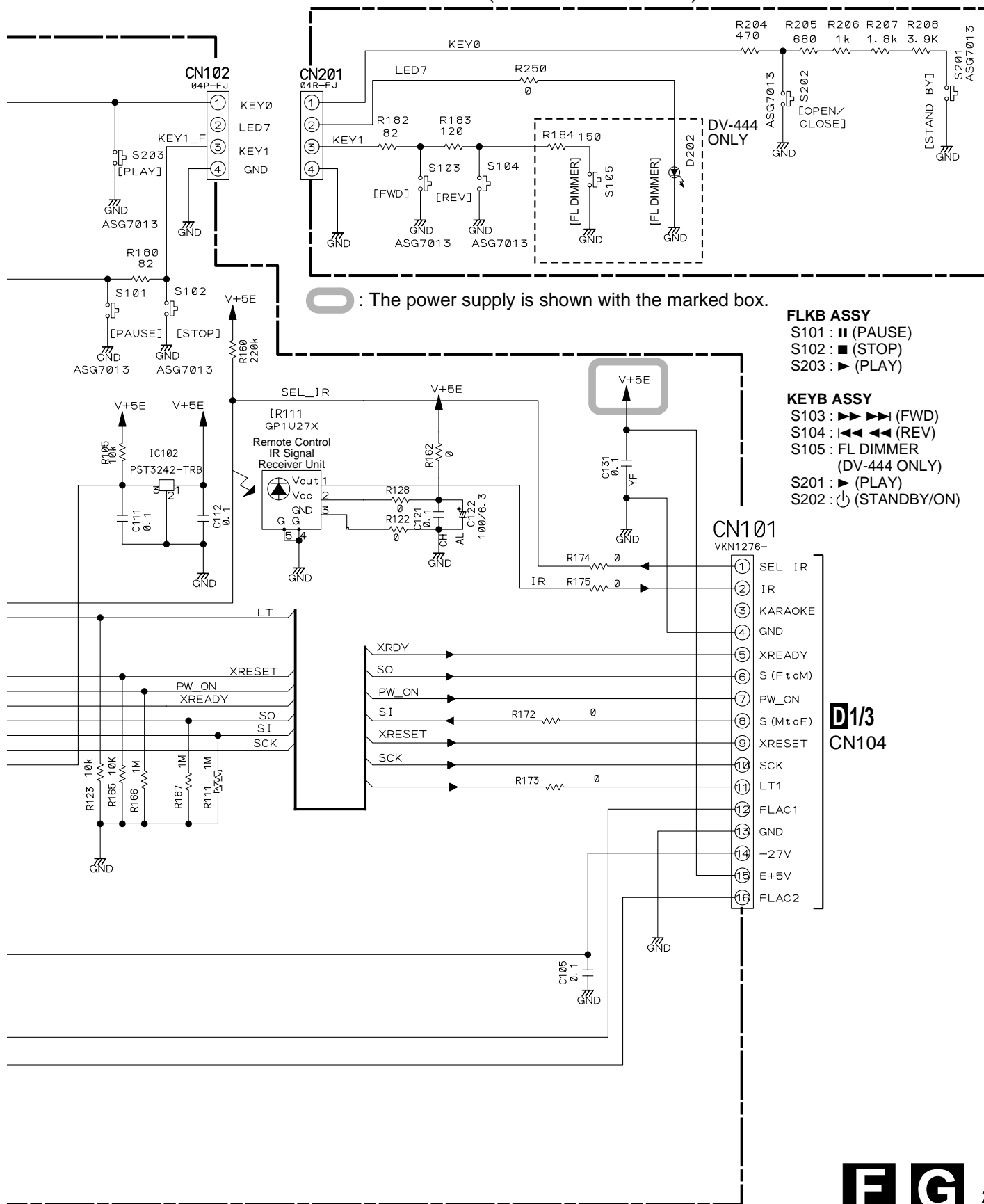

D1/3
CN104

30

POWER SUPPLY UNIT (VWR1339)

NOTE OF SPARE PARTS IN POWER SUPPLY (SYPS) UNIT

- In case of repairing, use the described parts only to prevent an accident.
- Please write the red ✓ mark on the board when the primary section of POWER SUPPLY (SYPS) Unit is repaired.
- Please take care to keep the space, not touching other parts when replacing the parts.

CAUTION : FOR CONTINUED PROTECTION AGAINST RISK OF FIRE, REPLACE ONLY WITH SAME TYPE NO. 491.800 MFD., BY LITTELFUSE INC. FOR P101 (AEK7063).

CAUTION : FOR CONTINUED PROTECTION AGAINST RISK OF FIRE, REPLACE ONLY WITH SAME TYPE NO. 49101.6 MFD., BY LITTELFUSE INC. FOR P102 (AEK7066).

D1/3
CN101

NOTE FOR FUSE REPLACEMENT

CAUTION - FOR CONTINUED PROTECTION AGAINST RISK OF FIRE, REPLACE WITH SAME TYPE AND RATINGS ONLY.

A

B

C

D

2

3

4

WAVEFORMS

Note : The encircled numbers denote measuring point in the schematic diagram.

B DVDM ASSY

Measurement condition : No. 1 to 4 and 6 to 11 : MJK1, Title 1-chp 1
 No. 5 : CD, ABEX-784 Track 1

D JACB ASSY

Measurement condition : No. 1 to 5 : DVD-REF-A1, T1-Chap.1
 No. 6 to 10 : DVD-REF-A1, T1-Chap.19

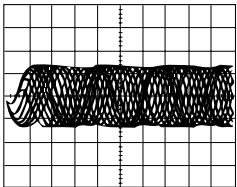
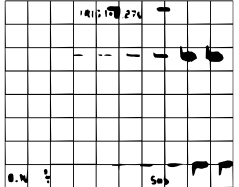
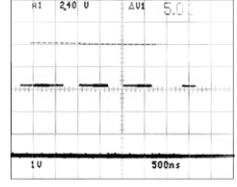
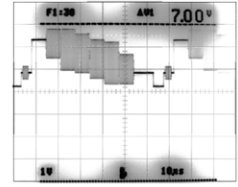
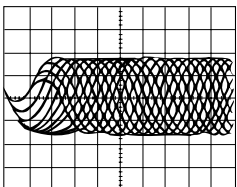
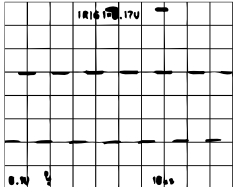
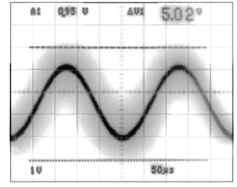
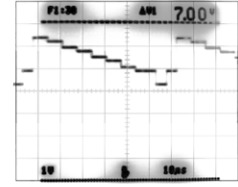
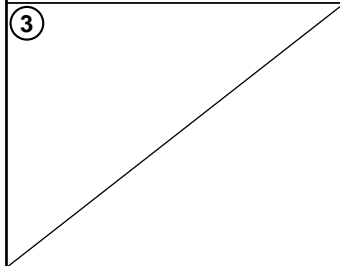
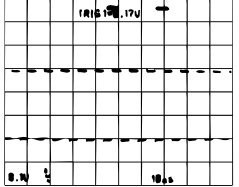
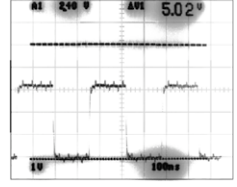
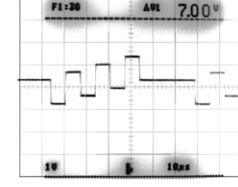
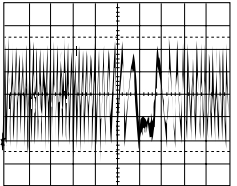
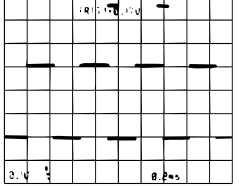
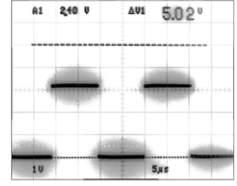
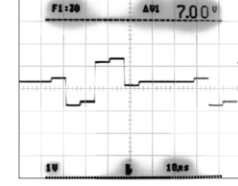
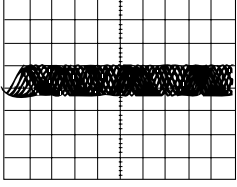
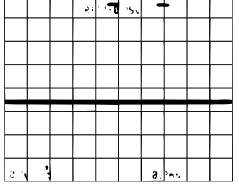
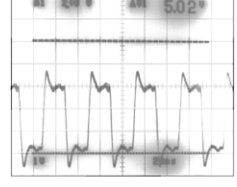
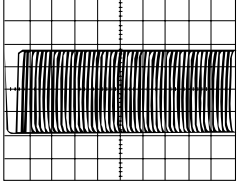
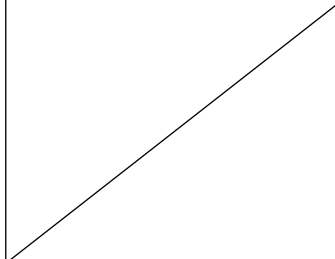
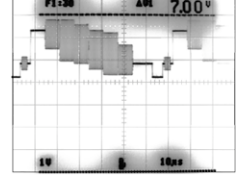
<p>① Foot of R104 (RF) V: 100mV/div. H: 0.2μsec/div.</p> 	<p>⑦ TP209 (FG) V: 1V/div. H: 5msec/div.</p> 	<p>① IC211 - pin 2 (ADATA) V: 1V/div. H: 500nsec/div.</p> 	<p>⑦ IC411 - pin 27 (V) V: 1V/div. H: 10μsec/div.</p> 
<p>② TP117 (RFO) V: 500mV/div. H: 0.1μsec/div.</p> 	<p>⑧ Foot of R261 (FPWM) V: 1V/div. H: 5msec/div.</p> 	<p>② IC211 - pin 7, 8 (AUDIO L, R) V: 1V/div. H: 50μsec/div.</p> 	<p>⑧ IC411 - pin 20, 23 (Y) V: 1V/div. H: 10μsec/div.</p> 
<p>③</p> 	<p>⑨ Foot of R262 (VPWM) V: 1V/div. H: 5msec/div.</p> 	<p>③ IC211 - pin 1 (BCK) V: 1V/div. H: 100nsec/div.</p> 	<p>⑨ IC411 - pin 18 (Cb) V: 1V/div. H: 10μsec/div.</p> 
<p>④ TP122 (Tracking Error) (AI-Inner Tracking Off) V: 500mV/div. H: 2msec/div.</p> 	<p>⑩ Foot of R263 (PPWM) V: 1V/div. H: 5msec/div.</p> 	<p>④ IC211 - pin 3 (LRCK) V: 1V/div. H: 5μsec/div.</p> 	<p>⑩ IC411 - pin 16 (Cr) V: 1V/div. H: 10μsec/div.</p> 
<p>⑤ IC201 - pin 39 (EFM before slice) V: 1V/div. H: 1μsec/div.</p> 	<p>⑪ Foot of R264 (RPWM) V: 1V/div. H: 5msec/div.</p> 	<p>⑤ IC211 - pin 16 (MCK) V: 1V/div. H: 20nsec/div.</p> 	
<p>⑥ IC201 - pin 1 (EFM) V: 1V/div. H: 0.2μsec/div.</p> 	<p>⑥</p> 	<p>⑥ IC411 - pin 25 (C) V: 1V/div. H: 10μsec/div.</p> 	

4. PCB CONNECTION DIAGRAM

NOTE FOR PCB DIAGRAMS :

1. Part numbers in PCB diagrams match those in the schematic diagrams.
2. A comparison between the main parts of PCB and schematic diagrams is shown below.

Symbol In PCB Diagrams	Symbol In Schematic Diagrams	Part Name
		Transistor
		Transistor with resistor
		Field effect transistor
		Resistor array
		3-terminal regulator

3. The parts mounted on this PCB include all necessary parts for several destinations.
For further information for respective destinations, be sure to check with the schematic diagram.
4. View point of PCB diagrams.

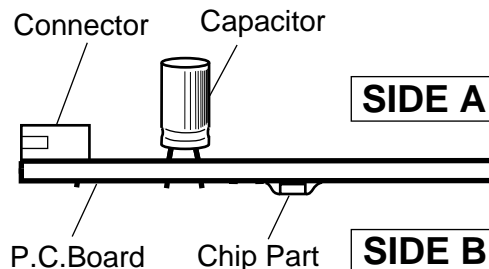

4.1 LOAB and SSIB ASSYS

A LOAB ASSY

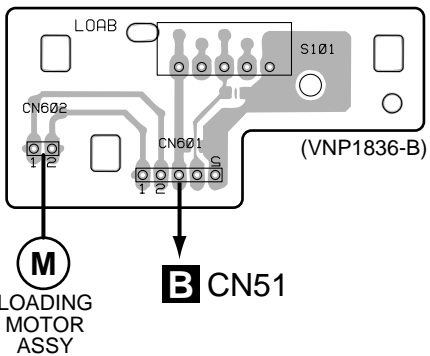

A LOAB ASSY

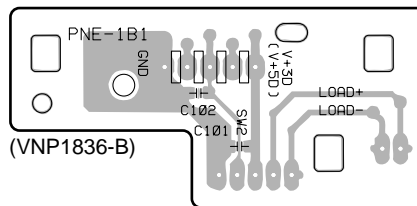

C SSIB ASSY

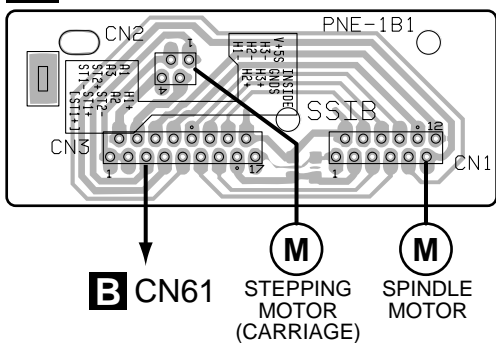

C SSIB ASSY

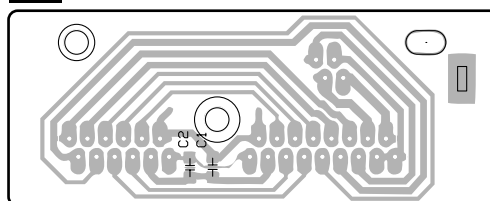

(DV-444/KUXQ, KCXQ, DV-440/KUXQ : VNP1821-C)
(DV-440/KUXJ, KCXJ : VNP1820-E)

SIDE A

SIDE B

4.2 DVDM ASSY

B DVDM ASSY

D CN102

PICKUP ASSY

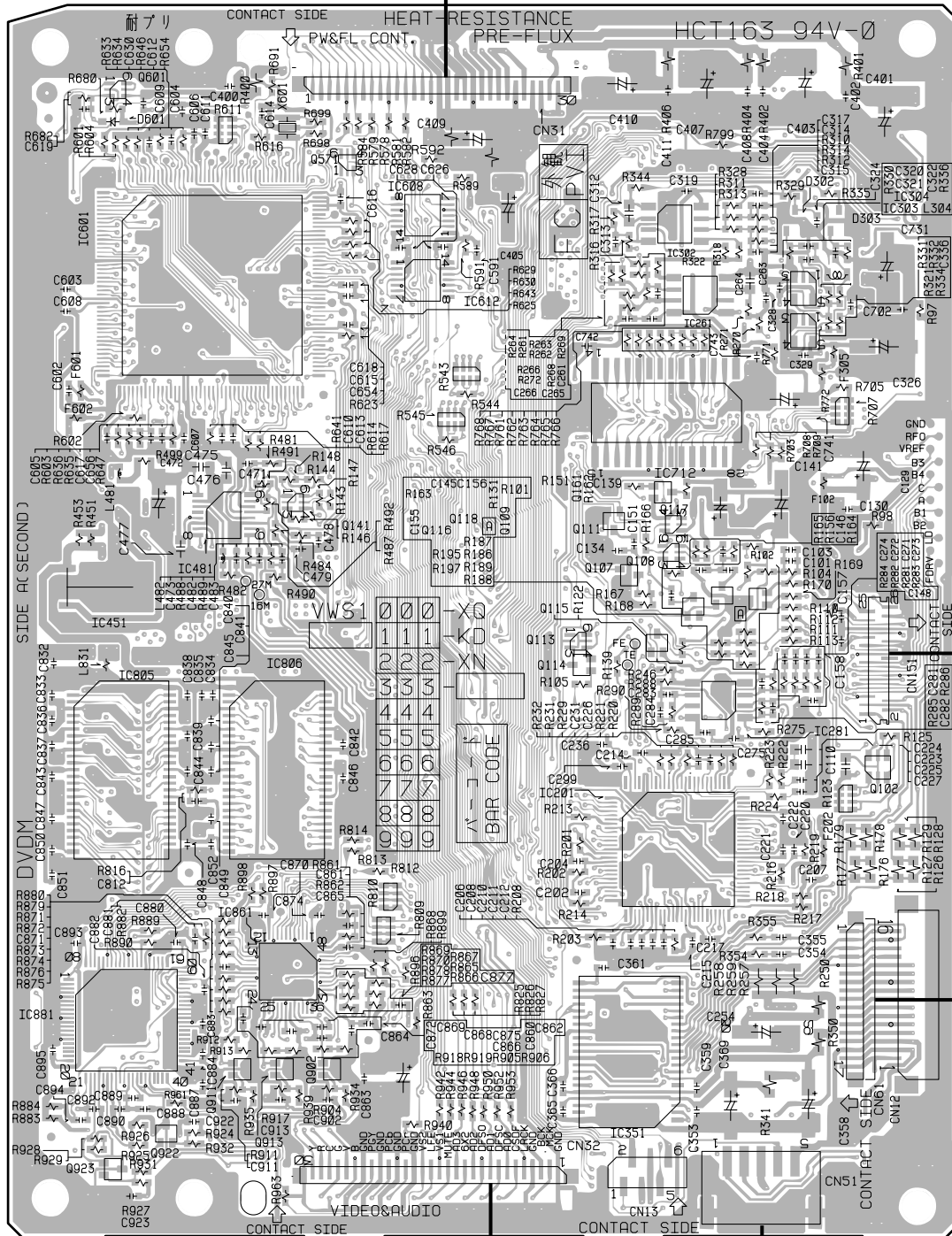

- Q601
- Q571
- IC608 IC302
- IC612 IC304
- IC601 IC261 IC303
- IC712
- Q141 Q117
- IC481 Q108
- Q107 Q118 Q109
- Q115 Q114
- IC281
- IC805 IC806 Q102
- IC201
- IC861
- IC881
- IC351 Q911 Q913 Q902
- Q922
- Q923

(DV-444/KUXQ, KCXQ, DV-440/KUXQ : VNP1823-A)
 (DV-440/KUXJ, KCXJ : VNP1822-A)

D CN106

A CN601

C CN3

SIDE A

B

B DVDM ASSY

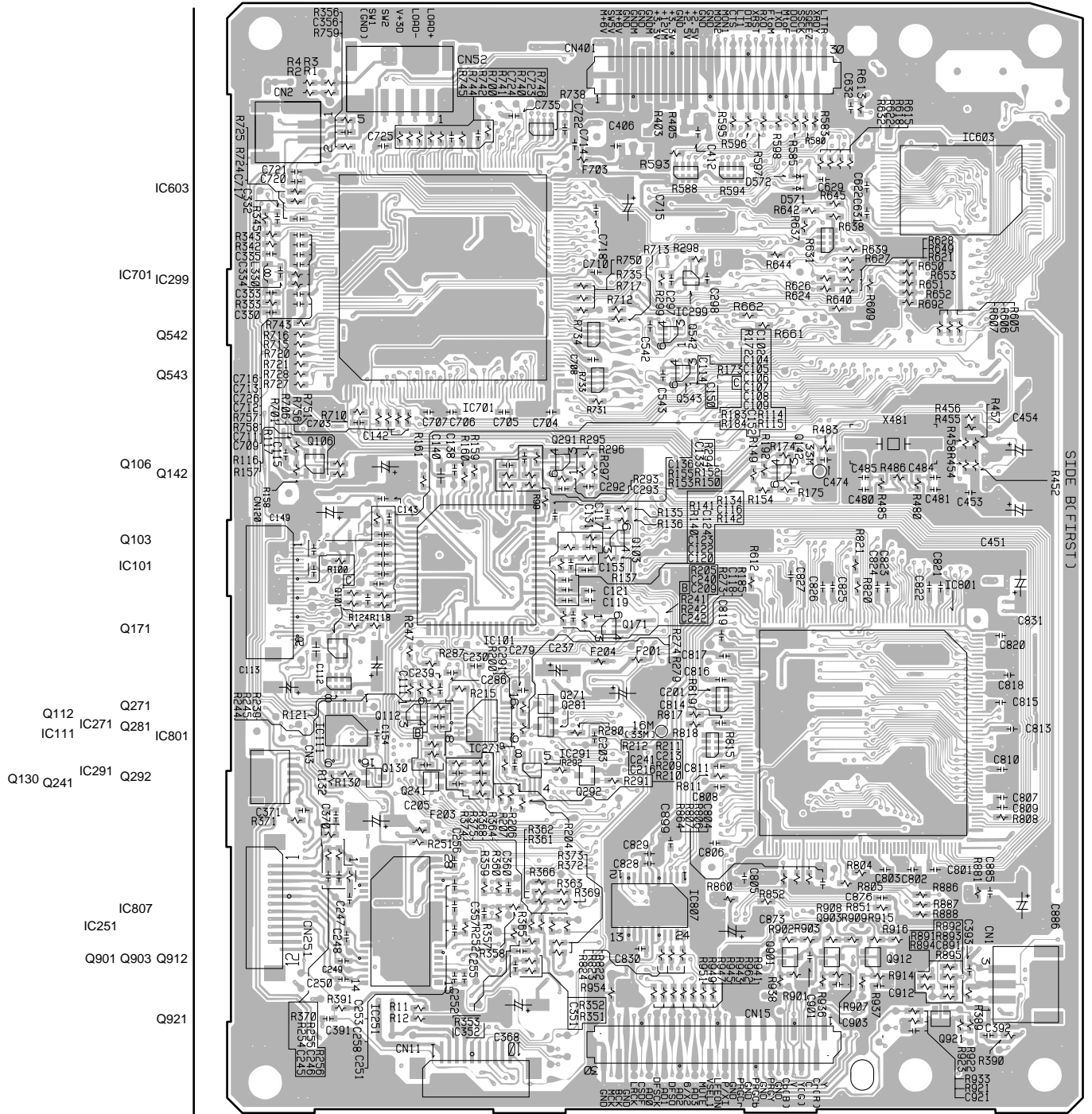

IC603
 IC701
 IC299
 Q542
 Q543
 Q106
 Q142
 Q103
 IC101
 Q171
 Q112
 IC271
 IC281
 IC801
 Q271
 Q281
 IC291
 Q292
 Q130
 Q241
 IC807
 IC251
 Q901
 Q903
 Q912
 Q921

SIDE B (FIRST)

(DV-444/KUXQ, KCXQ, DV-440/KUXQ : VNP1823-A)
 (DV-440/KUXJ, KCXJ : VNP1822-A)

SIDE B

B

4.3 JACB ASSY

A

B

C

D

D JACB ASSY

F
CN101

B
CN31

B
CN32

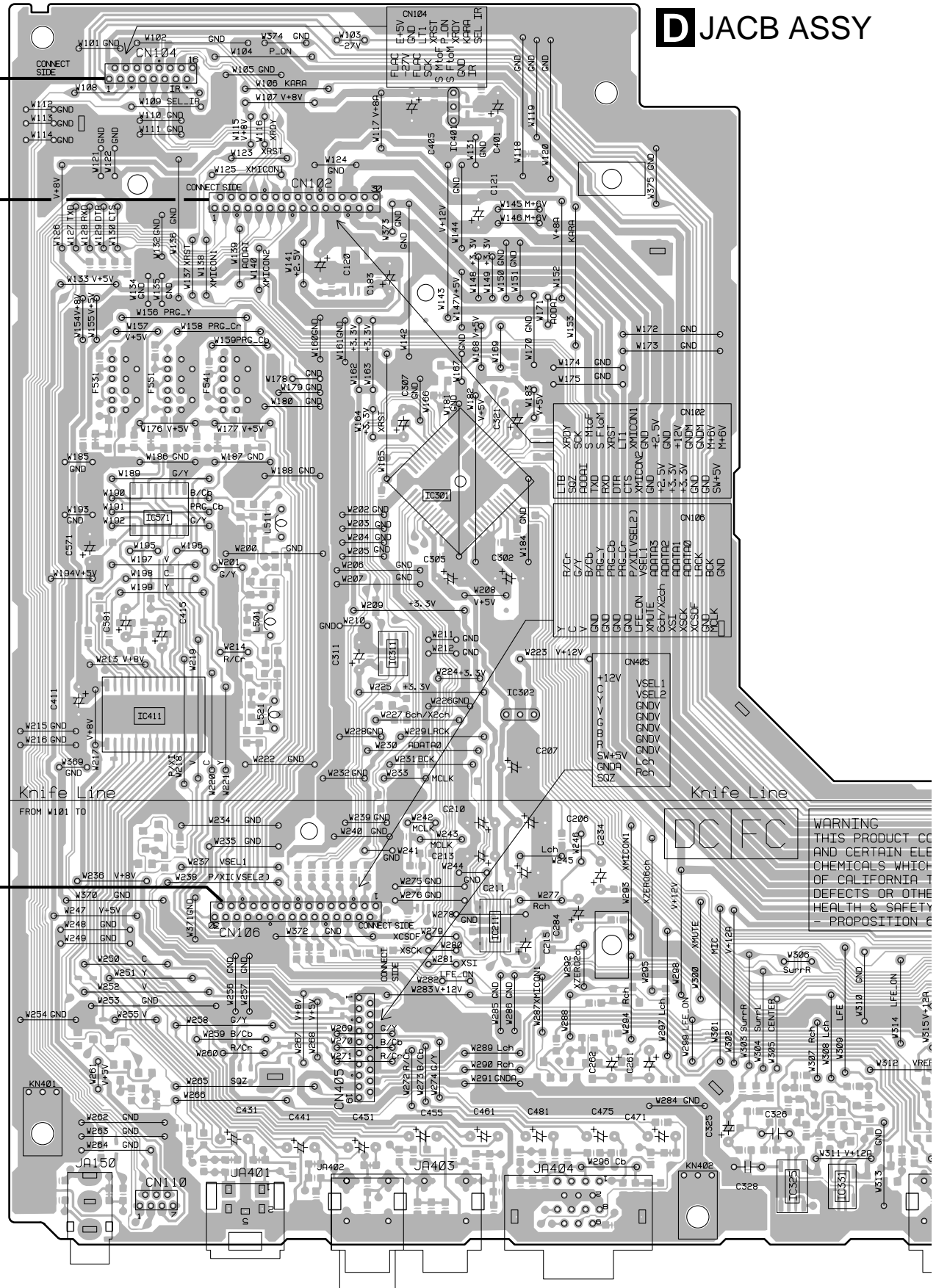

D

SSY

SIDE A

(DV-444/KUXQ, KCXQ, DV-440/KUXQ : VNP1821-C)
(DV-440/KUXJ, KCXJ : VNP1820-E)

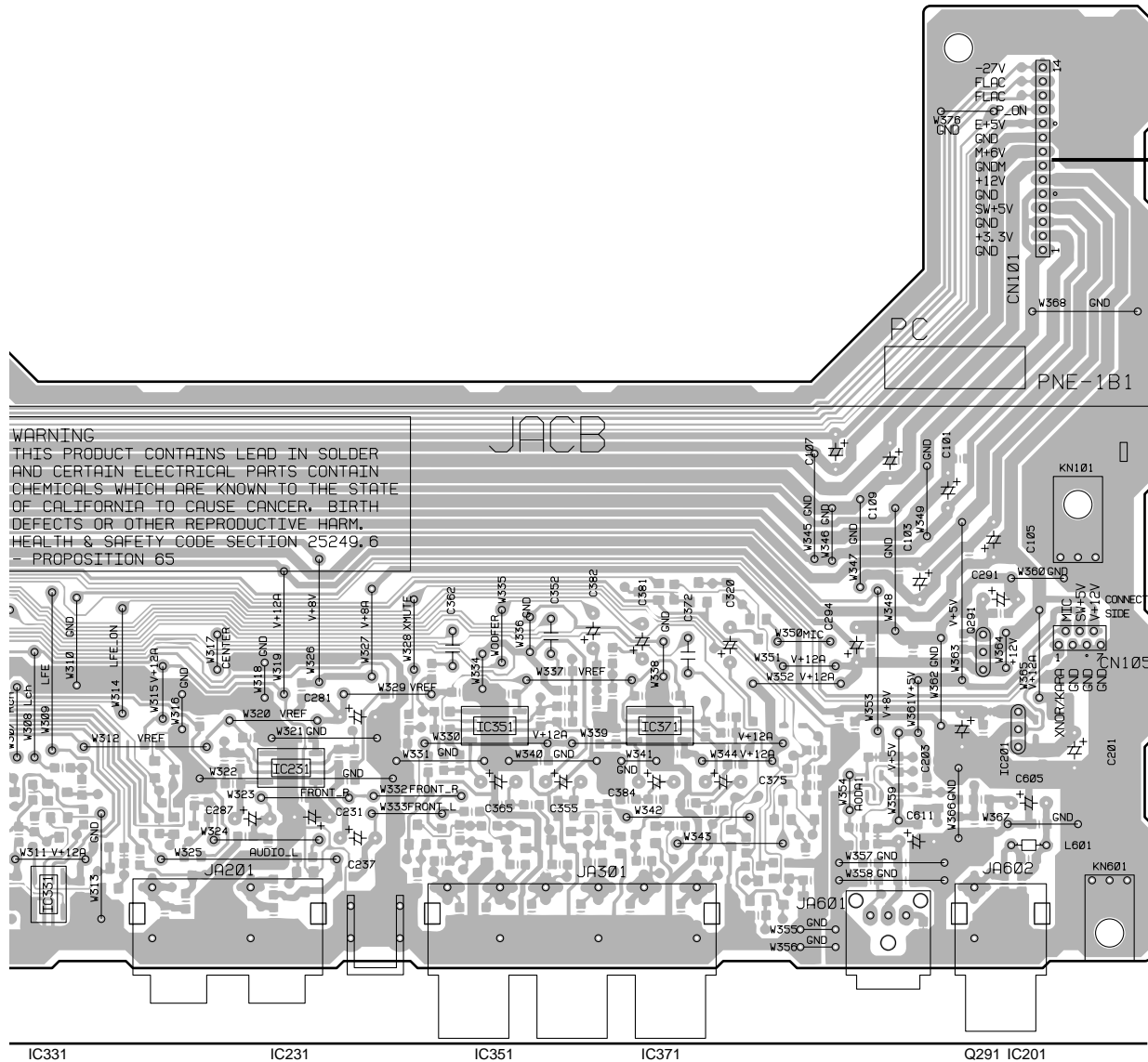

CN101

IC331

IC231

IC351

IC371

Q291 IC201





SIDE B

(DV-444/KUXQ, KCXQ, DV-440/KUXQ : VNP1821-C)
(DV-440/KUXJ, KCXJ : VNP1820-E)

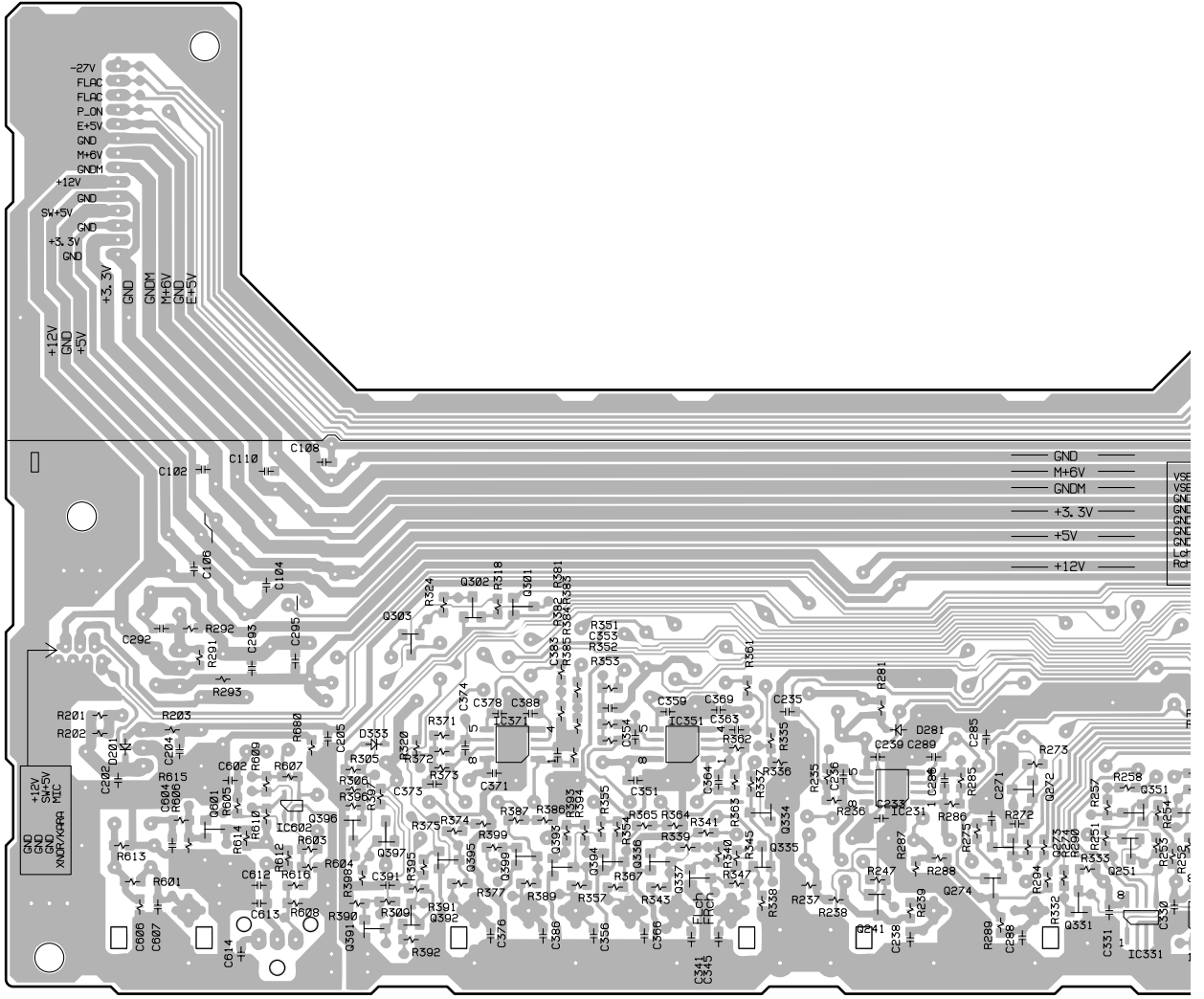

Q601 IC602 Q301-Q303 IC371 Q399 Q391-Q397 IC371 Q399 IC351 Q334-Q337 IC231 Q241 Q272-Q274 Q331 Q351 Q251 IC331



D JACB ASSY

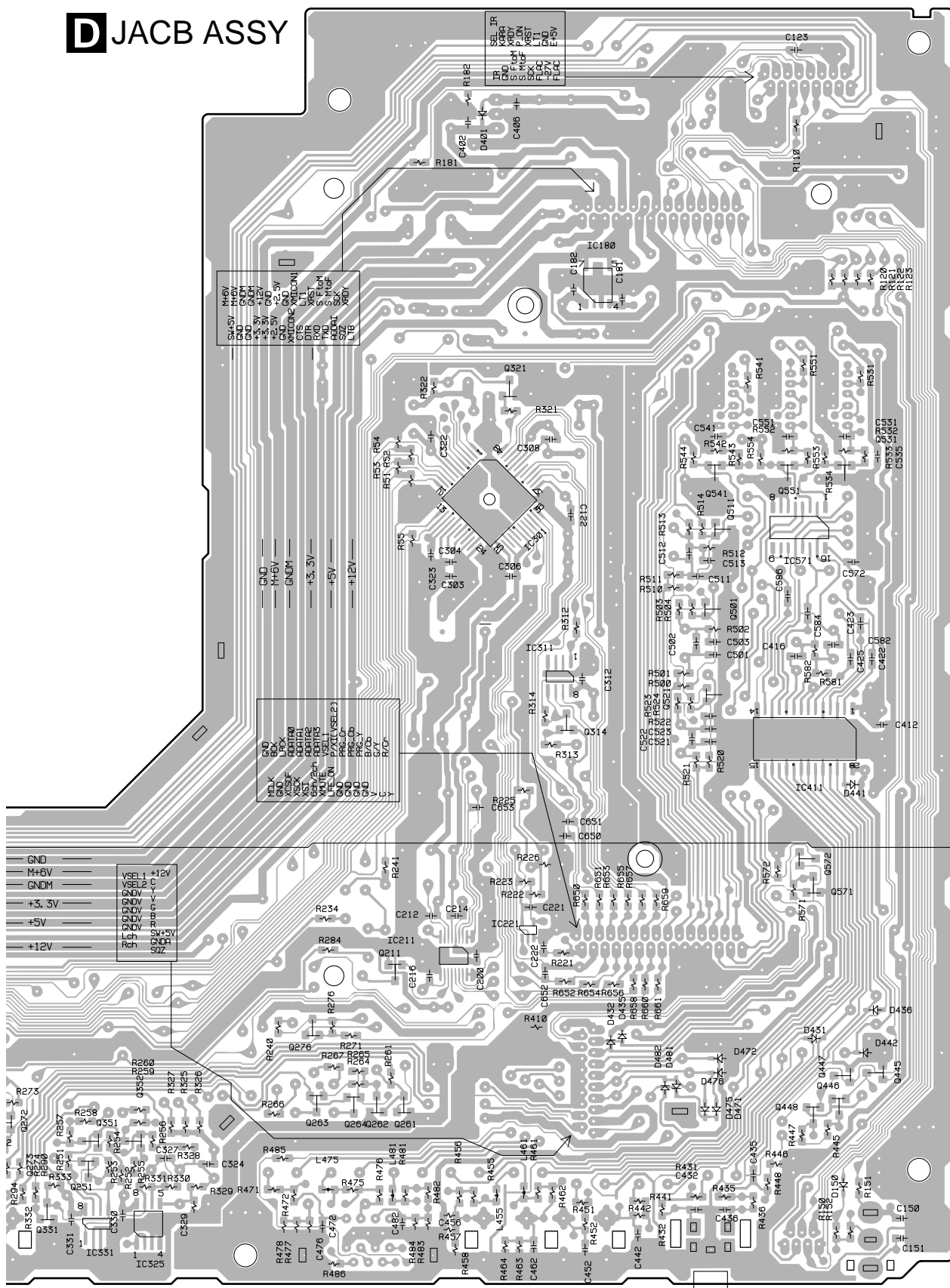

- Q331 Q351 Q352 Q276 Q211 IC211 Q321 IC311 IC180 Q541 Q551 Q531
- Q331 Q251 IC325 Q261-Q264 IC221 IC301 IC221 Q314 Q501 Q511 IC411 Q571 Q571
- IC331 Q445-Q448



4.4 FLKB ASSY

F FLKB ASSY

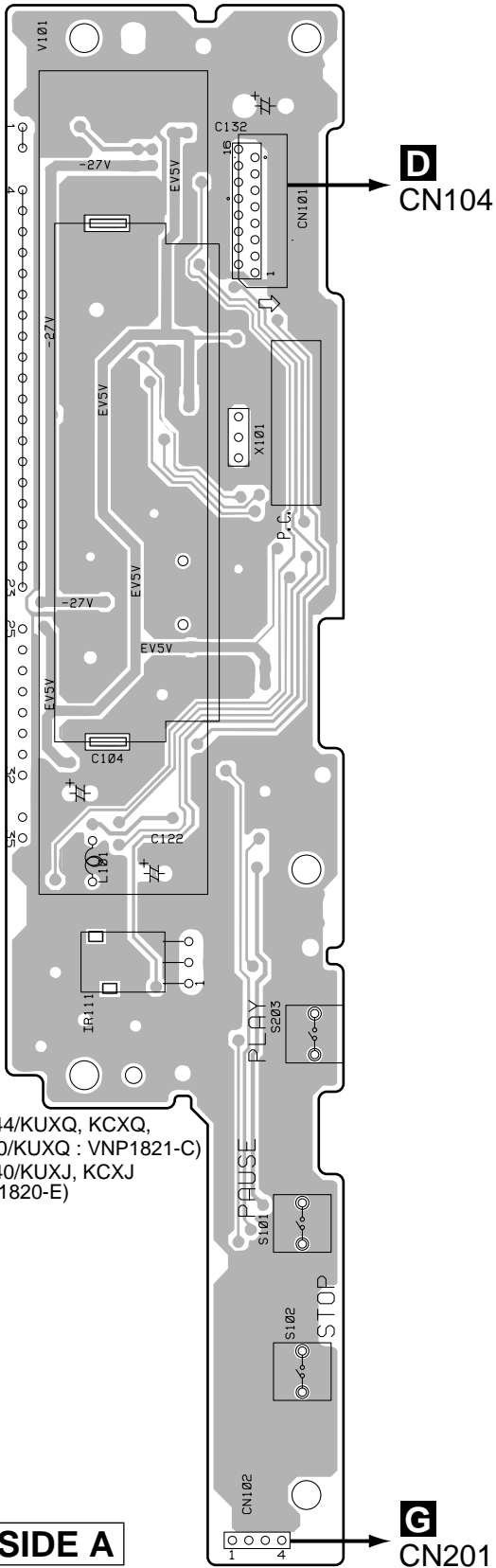

F FLKB ASSY

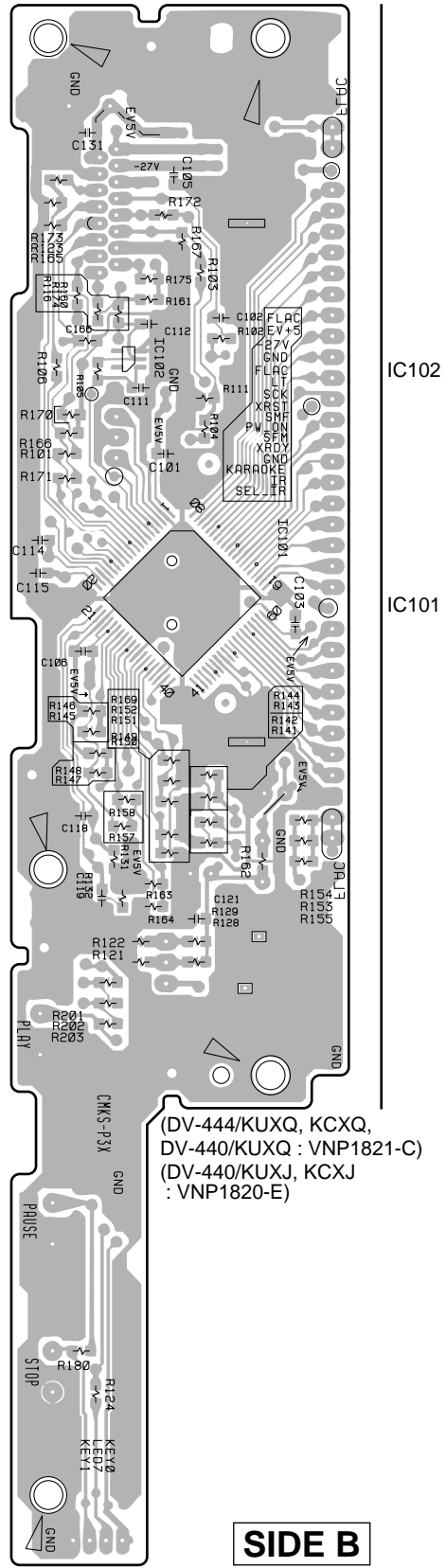

4.5 KEYB ASSY

G KEYB ASSY

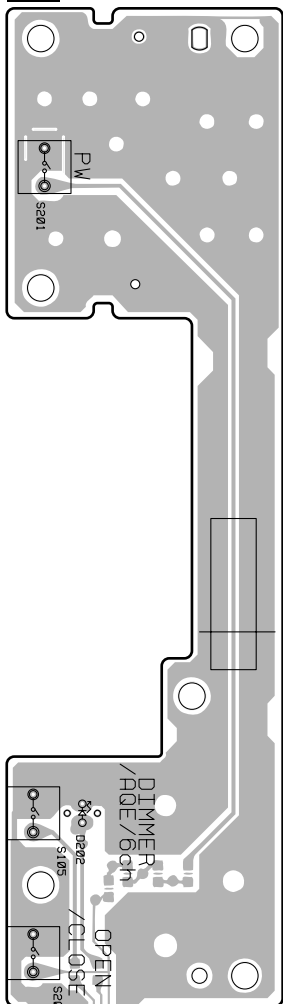

(DV-444/KUXQ, KCXQ, DV-440/KUXQ : VNP1835-B)
 (DV-440/KUXJ, KCXJ : VNP1834-B)

F CN102

SIDE A

G KEYB ASSY

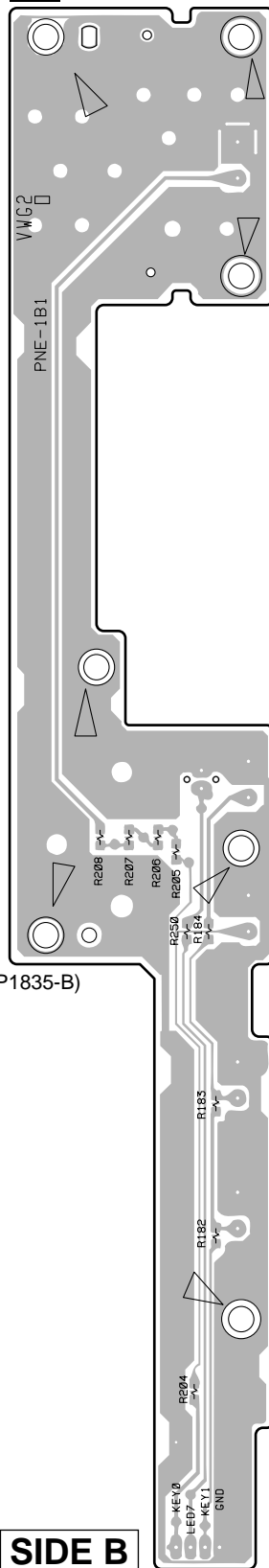

SIDE B

4.6 POWER SUPPLY UNIT (VWR1339)

A

B

C

D

AC IN ←

H POWER SUPPLY UNIT

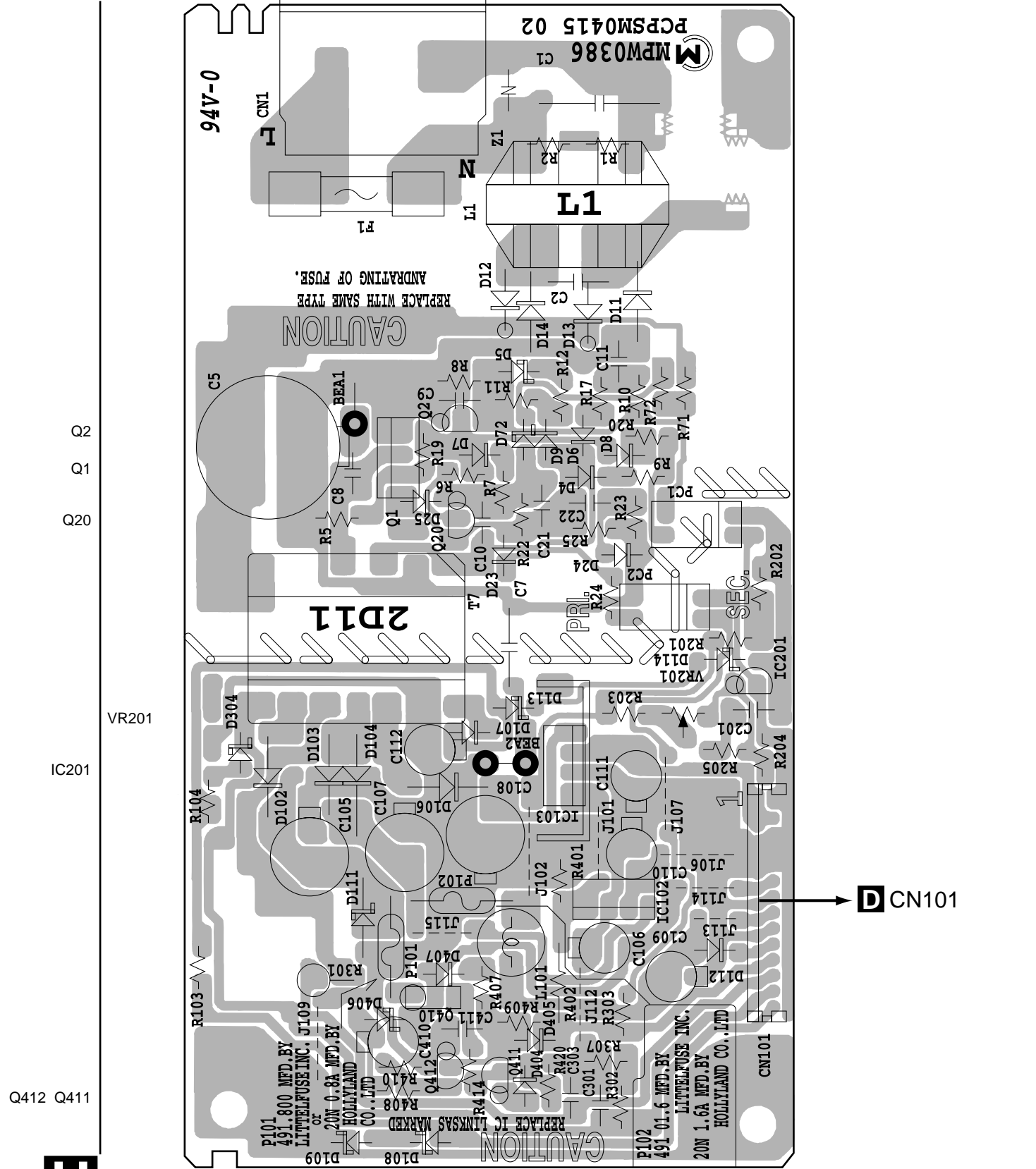

Q2
Q1
Q20

VR201

IC201

Q412 Q411

D CN101

SIDE A



5. PCB PARTS LIST

NOTES: ●Parts marked by "NSP" are generally unavailable because they are not in our Master Spare Parts List.

●The Δ mark found on some component parts indicates the importance of the safety factor of the part.

Therefore, when replacing, be sure to use parts of identical designation.

●When ordering resistors, first convert resistance values into code form as shown in the following examples.

Ex.1 When there are 2 effective digits (any digit apart from 0), such as 560 ohm and 47k ohm (tolerance is shown by J=5%, and K=10%).

560 Ω \rightarrow 56×10^1 \rightarrow 561 RD1/4PU $\begin{matrix} \boxed{5} & \boxed{6} & \boxed{1} \\ \boxed{J} \end{matrix}$

47k Ω \rightarrow 47×10^3 \rightarrow 473 RD1/4PU $\begin{matrix} \boxed{4} & \boxed{7} & \boxed{3} \\ \boxed{J} \end{matrix}$

0.5 Ω \rightarrow R50 RN2H $\begin{matrix} \boxed{R} & \boxed{5} & \boxed{0} \\ \boxed{K} \end{matrix}$

1 Ω \rightarrow 1R0 RSIP $\begin{matrix} \boxed{1} & \boxed{R} & \boxed{0} \\ \boxed{K} \end{matrix}$

Ex.2 When there are 3 effective digits (such as in high precision metal film resistors).

5.62k Ω \rightarrow 562×10^1 \rightarrow 5621 RN1/4PC $\begin{matrix} \boxed{5} & \boxed{6} & \boxed{2} & \boxed{1} \\ \boxed{F} \end{matrix}$

■ LIST OF HOLE PCB ASSEMBLIES

Mark	Symbol and Description	Part No.			Remarks
		DV-444	DV-440		
		KUXQ, KCXQ	KUXQ	KUXJ, KCXJ	
NSP NSP	Loading Mechanism Assy └ LOAB Assy	VWT1188 VWG2279	VWT1188 VWG2279	VWT1188 VWG2279	
	DVDM Assy	VWS1485	VWS1487	VWS1487	
NSP	JSMB Assy └ SSIB Assy └ JACB Assy	VWM2081 VWG2292 VWV1840	VWM2114 VWG2292 VWV1899	VWM2085 VWG2292 VWV1844	
NSP NSP	FLKB Assy KEYB Assy	VWG2280 VWG2289	VWG2332 VWG2290	VWG2332 VWG2290	
Δ	POWER SUPPLY Unit	VWR1339	VWR1339	VWR1339	

B DVDM ASSY

VWS1485 and VWS1487 are constructed the same except for the following :

Mark	Symbol and Description	Part No.		Remarks
		VWS1485	VWS1487	
	IC881 Q921-Q923 L489 C142 C254, C401	PM0026A 2SA1576A Not used CEV101M16 CEV470M16	Not used Not used VTL1078 CEV221M4 CEV101M16	
	C407, C741 C607, C710, C714 C880-C882, C885 C882, C883, C887, C889-C893, C895, C921 R3	Not used Not used CKSRYF105Z10 CKSRYF104Z25 RS1/16S333J	CEV101M16 CKSRYF105Z10 Not used Not used RS1/16S103J	
	R4 R489 R622 R882, R890, R923, R926, R963 R893	RS1/16S103J RS1/16S220J Not used RS1/16S0R0J RS1/16S6800F	RS1/16S333J Not used RS1/16S103J Not used Not used	
	R894 R895 R921, R924, R927 R922, R925, R928 R929	RS1/16S3001F RS1/161201F RS1/16S182J RS1/16S1000F RS1/16S100J	Not used Not used Not used Not used Not used	

D JACB ASSY

VWV1840, VWV1899 and VWV1844 are constructed the same except for the following :

Mark	Symbol and Description	Part No.		Remarks
		VWV1840	VWV1899, VWV1844	
	IC411 IC571 Q501, Q511, Q521, Q531, Q541, Q551 Q571 Q572	MM1540CF TC74HC4053AF 2SA1037K DTC114YK PDTA124EK	MM1540BF Not used Not used Not used Not used	
	F531, F541, F551 L501, L511, L521 C501, C502, C511, C512, C521 C522, C531, C541, C551 C503, C513, C523	VTF1158 LAU120J CCSRCH6R0D50 CCSRCH6R0D50 CCSRCH180J50	Not used Not used Not used Not used Not used	
	C535, C572 R500, R510, R520 R501, R511, R521 R504, R514, R524, R534, R544, R554 R531, R541, R551	CKSRYP104Z25 Not used RS1/16S821J RS1/16S182J RS1/16S331J	Not used RS1/16S0R0J Not used Not used Not used	
	R532, R542, R552 R571, R572	RS1/16S223J RS1/16S222J	Not used Not used	

F FLKB ASSY

VWG2280 and VWG2332 are constructed the same except for the following :

Mark	Symbol and Description	Part No.		Remarks
		VWG2280	VWG2332	
	R124 R145 R146	RS1/16S331J RS1/16S0R0J Not used	Not used Not used RS1/16S0R0J	

G KEYB ASSY

VWG2289 and VWG2290 are constructed the same except for the following :

Mark	Symbol and Description	Part No.		Remarks
		VWG2289	VWG2290	
	D202 S105 R184	SLR-343VC ASG7013 RS1/16S151J	Not used Not used Not used	

PCB PARTS LIST FOR DV-444/KUXQ UNLESS OTHERWISE NOTED

Mark	No.	Description	Part No.	Mark	No.	Description	Part No.
A LOAB ASSY							
SWITCHES AND RELAYS							
	S101		VSK1011		C151		CCSRCH270J50
					C391, C392		CCSRCH331J50
					C146		CCSRCH390J50
					C122, C123		CCSRCH391J50
					C116, C134, C297		CCSRCH470J50
OTHERS							
	CN602	CONNECTOR	S2B-PH-K		C145, C241		CCSRCH560J50
	CN601	CONNECTOR	S5B-PH-K		C117, C360		CCSRCH681J50
		PRINTED CIRCUIT BOARD	VNP1837		C124		CCSRCH820J50
					C129, C142, C149, C201, C205		CEV101M16
					C358, C368, C369, C403, C410		CEV101M16
					C472, C864		CEV101M16
					C113, C139		CEV220M16
					C405, C454, C715		CEV221M4
					C254, C401		CEV470M16
					C111		CEV470M6R3
B DVDM ASSY							
SEMICONDUCTORS							
	IC861		ADV7172KST		C140, C223, C224, C264, C312		CKSQYB105K10
△	IC451		BA25BC0FP		C475-C477		CKSQYB105K10
	IC261, IC302		BA4510F		C209, C211, C216, C313, C351		CKSRYB102K50
	IC251		BA6664FM		C133, C136, C203, C220, C225		CKSRYB103K50
	IC481		BU2288FV		C239, C261, C320, C321, C330		CKSRYB103K50
	IC101		LA9701M		C591, C619, C703, C722		CKSRYB103K50
	IC201		LC78652W		C101, C103, C118, C119, C121		CKSRYB104K16
	IC351		M56788AFP		C212, C213, C227, C231		CKSRYB104K16
	IC801		M65774BFP		C248-C251, C255, C263, C315		CKSRYB104K16
	IC805		MB81F161622C-80FN		C317		CKSRYB104K16
	IC712		MNR4800DJ7		C208, C210		CKSRYB222K50
	IC601		PD6345A		C266		CKSRYB224K10
	IC701		PE5108A		C206, C214, C242, C357		CKSRYB472K50
	IC881		PM0026A		C102, C109, C120, C130, C131		CKSRYF104Z25
	IC111		TC74HC4053AFT		C138, C143, C148, C154		CKSRYF104Z25
	IC612		TC74VHC125FT		C157, C158, C204, C207, C215		CKSRYF104Z25
	IC608		TC74VHCT125AFT		C221, C222, C226, C230, C236		CKSRYF104Z25
	IC304		TC7SHU04F		C253, C256, C258, C265, C299		CKSRYF104Z25
	IC603		VYW1857		C319, C332, C353, C359		CKSRYF104Z25
	Q109, Q901-Q903, Q911-Q913		2SA1576A		C365, C366, C453, C603, C606		CKSRYF104Z25
	Q921-Q923		2SA1576A		C608-C611, C613, C615, C618		CKSRYF104Z25
	Q114, Q130		2SC4081		C626, C628, C631, C704, C706		CKSRYF104Z25
	Q107, Q111, Q115, Q241		DTC114EUA		C708, C712, C713, C716-C718		CKSRYF104Z25
	Q101, Q102, Q106		HN1A01F		C721, C723, C725, C743, C802		CKSRYF104Z25
	Q103, Q141, Q142, Q542, Q543		HN1B04FU		C808, C811, C814, C866		CKSRYF104Z25
	Q112, Q113		HN1C01FU		C869-C872, C874, C875		CKSRYF104Z25
	Q108		HN1K03FU		C882, C883, C887, C889-C893		CKSRYF104Z25
	Q571		RN1911		C895, C903, C913, C921		CKSRYF104Z25
	Q117, Q171, Q601		RN4982		C115, C217, C328, C614, C711		CKSRYF105Z10
	D302		KV1470		C726, C801, C809, C813		CKSRYF105Z10
	D601		RB501V-40		C816-C821, C827, C833, C843		CKSRYF105Z10
					C880, C881, C885		CKSRYF105Z10
COILS AND FILTERS				RESISTORS			
	L304		LCYA1R5J2520		R815, R819		RAB4C0R0J
	L481	CHIP BEADS	VTL1084		R543, R545, R594, R631, R707		RAB4C103J
CAPACITORS					R121		RAB4C220J
	C480, C481, C612		CCSRCH100D50		R123		RAB4C470J
	C152		CCSRCH101J50		R400, R403		RS1/10S0R0J
	C104-C108		CCSRCH150J50		R341		RS1/10S101J
	C322		CCSRCH180J50		R126-R129, R176-R179		RS1/10S220J
	C314		CCSRCH220J50		R902, R905, R908, R912, R915		RS1/16S1000F
					R918, R922, R925, R928		RS1/16S1000F
					R364, R369, R373, R375		RS1/16S1003F

DV-444, DV-440

Mark	No.	Description	Part No.
	R895		RS1/16S1201F
	R865		RS1/16S1502F
	R358, R361		RS1/16S1503F
	R894		RS1/16S3001F
	R876, R878		RS1/16S4701F
	R866		RS1/16S4702F
	R870, R875, R893		RS1/16S6800F
	R867		RS1/16S6801F
	R357, R362, R363, R368, R372		RS1/16S6802F
	R374		RS1/16S6802F
	R257 (1Ω ,1/4W)		VCN1127
	R258, R259 (2.2Ω ,1/4W)		VCN1128
	Other Resistors		RS1/16S□□□□

OTHERS

CN51	CONNECTOR FLEXIBLE CABLE	S5B-PH-SM3
CN61	17P CONNECTOR	VDA1681
CN31, CN32	30P CONNECTOR	VKN1421
CN151	26P CONNECTOR	VKN1434
		VKN1790
X481	(27.000MHz)	VSS1159
X601	(16.5MHz)	VSS1160

C SSIB ASSY

OTHERS

CN2	4P CONNECTOR	VKN1264
CN1	12P CONNECTOR	VKN1272
CN3	17P CONNECTOR	VKN1277

D JACB ASSY

SEMICONDUCTORS

IC231		BA4560F
IC411		MM1540CF
△ IC302		NJM78L05A
IC401		NJM78L08A
IC211		PCM1742KE
IC571		TC74HC4053AF
Q273, Q501, Q511, Q521, Q531		2SA1037K
Q541, Q551		2SA1037K
Q601		2SC2412K
Q241, Q274		2SD2114K
Q211, Q272, Q445, Q447, Q571		DTC114YK
Q446, Q448, Q572		PDTA124EK
D150, D431, D432, D435, D436		1SS355
D441, D442, D471, D472		1SS355
D475, D476, D481, D482		1SS355
D281		UDZS6.2B

COILS AND FILTERS

L501, L511, L521		LAU120J
L601	COIL	RTF1167
F531, F541, F551	12MHZ LPF(VIDEO)	VTF1158
L455, L461	CHIP BEADS	VTL1089

Mark	No.	Description	Part No.
CAPACITORS			
	C503, C513, C523		CCSRCH180J50
	C236, C238, C286, C288		CCSRCH331J50
	C150		CCSRCH470J50
	C501, C502, C511, C512		CCSRCH6R0D50
	C521, C522, C531, C541, C551		CCSRCH6R0D50
	C581		CEAL100M16
	C411		CEAL101M10
	C415		CEAL470M10
	C405, C611		CEAT101M10
	C451		CEAT102M6R3
	C605		CEAT1R0M50
	C231, C237, C281, C287		CEAT470M16
	C105		CEAT471M16
	C431, C441, C455, C461		CEAT471M6R3
	C213, C215		CEJQ101M6R3
	C206, C211		CEJQ331M6R3
	C234, C284		CEJQ470M16
	C235, C285		CKSRYB272K50
	C106, C151, C212, C214, C216		CKSRYF104Z25
	C233, C239, C289, C406, C412		CKSRYF104Z25
	C416, C422, C423, C425, C435		CKSRYF104Z25
	C535, C572, C584, C586, C602		CKSRYF104Z25
	C612		CKSRYF104Z25

RESISTORS

R234, R284		RN1/16SE2201D
R236, R286		RN1/16SE4301D
R273		RS1/10S182J
R456, R462		RS1/16S1000F
R457, R458, R463, R464		RS1/16S4700F
R432, R436, R442, R452		RS1/16S75R0F
Other Resistors		RS1/16S□□□□

OTHERS

CN101	CONNECTOR 14P	14PL-FJ
CN401	SOCKET	AKP7008
JA601	OPTICAL LINK OUT	GP1FA550TZ
JA201	JACK	PKB1034
JA150	JACK	RKN1004
PCB BINDER		VEF1040
JA602	JACK	VKB1159
JA403	JACK	VKB1168
CN104	16P CONNECTOR	VKN1247
CN102, CN106	30P CONNECTOR	VKN1261
CN110	7P CONNECTOR	VKN1267
KN401, KN601	EARTH METAL FITTING	VNF1084

F FLKB ASSY

SEMICONDUCTORS

IC101		PE5251A
IC102		PST3242

SWITCHES AND RELAYS

S101, S102, S203		ASG7013
------------------	--	---------

Mark	No.	Description	Part No.
CAPACITORS			
	C111, C114, C118, C119		CCSRCH102J50
	C102		CCSRCH470J50
	C122		CEAL101M6R3
	C101, C103, C106, C112, C121		CKSRYP104Z25
	C131		CKSRYP104Z25
	C105		CKSRYP104Z50

RESISTORS			
	All Resistors		RS1/16S□□□J

OTHERS			
	CN102 CONNECTOR 4P		04P-FJ
	IR111 REMOTE RECEIVER UNIT		GP1U27X
	V101 FL TUBE		VAW1063
	SPACER		VEC2220
	CN101 16P CONNECTOR		VKN1276
	HOLDER		VNF1122
	PRINTED CIRCUIT BOARD		VNP1833
	X101 (5MHz)		VSS1142

KEYB ASSY

SEMICONDUCTORS			
	D202		SLR-343VC(NPQ)

SWITCHES AND RELAYS			
	S103-S105, S201, S202		ASG7013

RESISTORS			
	All Resistors		RS1/16S□□□J

OTHERS			
	CN201 CONNECTOR 4P		04R-FJ
	PRINTED CIRCUIT BOARD		VNP1835

POWER SUPPLY UNIT

OTHERS			
△	P101 PROTECTOR (800mA)		AEK7063
△	P102 PROTECTOR (1.6A)		AEK7066
△	FU1 FUSE (1.6A)		REK1077

6. ADJUSTMENT

6.1 ADJUSTMENT ITEMS AND LOCATION

■ Adjustment Items

[Mechanism Part]

- ① Tangential and Radial Height Coarse Adjustment
- ② DVD Jitter Adjustment
- ③ Initialize the Focus Sweep Setting

[Electrical Part]



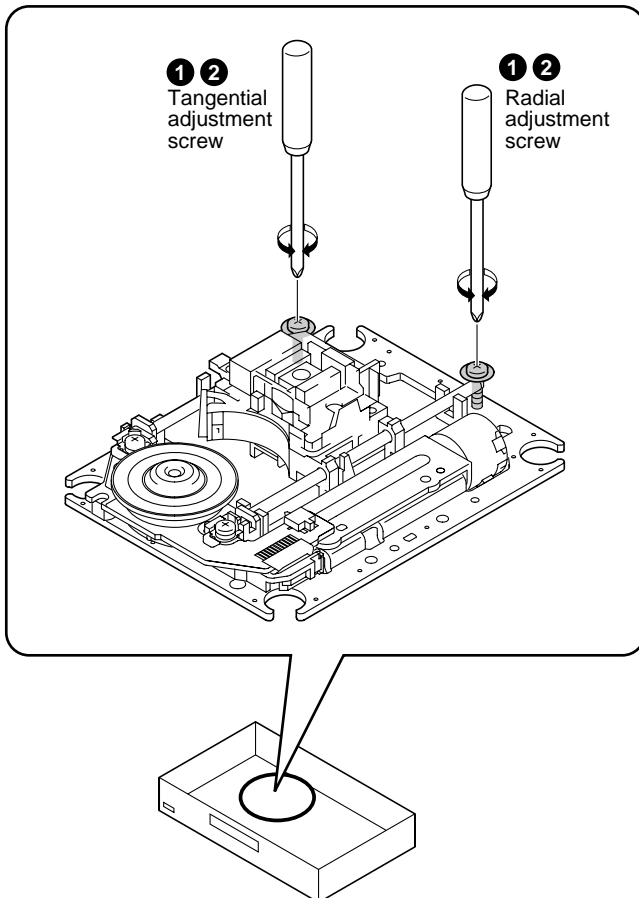

Electrical adjustments are not required.

■ Adjustment Points (Mechanism Part)

Cautions: After adjustment, adjustment screw locks with the Screw tight.

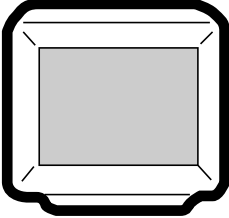
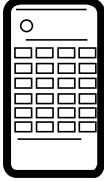

6.2 JIGS AND MEASURING INSTRUMENTS

 <p>⊕ Screwdriver (large)</p>	 <p>⊕ Screwdriver (medium)</p>
 <p>TV monitor</p>	 <p>Test mode remote control unit (GGF1067)</p>
 <p>⊕ Precise screwdriver</p>	 <p>DVD test disc (GGV1025)</p>
<p>Screw tight (GYL1001)</p>	

6.3 NECESSARY ADJUSTMENT POINTS

When	Adjustment Points						
■ Exchange Parts of Mechanism Assy							
Exchange the Pickup	<table border="1"> <tr> <td style="background-color: #cccccc;">Mechanical point</td> <td>①, ②, ③</td> <td>* After adjustment, screw locks with the Screw tight.</td> </tr> <tr> <td style="background-color: #cccccc;">Electric point</td> <td colspan="2">_____</td> </tr> </table>	Mechanical point	①, ②, ③	* After adjustment, screw locks with the Screw tight.	Electric point	_____	
Mechanical point	①, ②, ③	* After adjustment, screw locks with the Screw tight.					
Electric point	_____						
Exchange the Traverse Mechanism	<table border="1"> <tr> <td style="background-color: #cccccc;">Mechanical point</td> <td>③</td> <td></td> </tr> <tr> <td style="background-color: #cccccc;">Electric point</td> <td colspan="2">_____</td> </tr> </table>	Mechanical point	③		Electric point	_____	
Mechanical point	③						
Electric point	_____						
Exchange the Spindle Motor	<table border="1"> <tr> <td style="background-color: #cccccc;">Mechanical point</td> <td>②, ③</td> <td>* After adjustment, screw locks with the Screw tight.</td> </tr> <tr> <td style="background-color: #cccccc;">Electric point</td> <td colspan="2">_____</td> </tr> </table>	Mechanical point	②, ③	* After adjustment, screw locks with the Screw tight.	Electric point	_____	
Mechanical point	②, ③	* After adjustment, screw locks with the Screw tight.					
Electric point	_____						
■ Exchange PCB Assy							
Exchange PC Board SSIB, LOAB, DVDM ASSY	<table border="1"> <tr> <td style="background-color: #cccccc;">Mechanical point</td> <td colspan="2">_____</td> </tr> <tr> <td style="background-color: #cccccc;">Electric point</td> <td colspan="2">_____</td> </tr> </table>	Mechanical point	_____		Electric point	_____	
Mechanical point	_____						
Electric point	_____						

*

Purpose: To set the sweep which was correct with the individual Traverse mechanism.

Be sure to perform the following step finally when replaced Pickup, Traverse Mechanism and Spindle Motor.

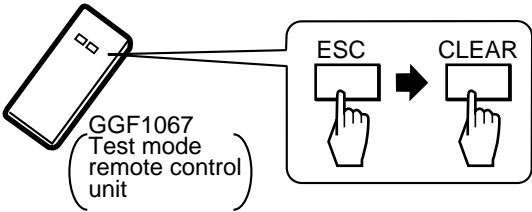

GGF1067
Test mode
remote control
unit

(It is necessary when performed adjustment procedure ②.)

6.4 TEST MODE

TEST MODE: ON

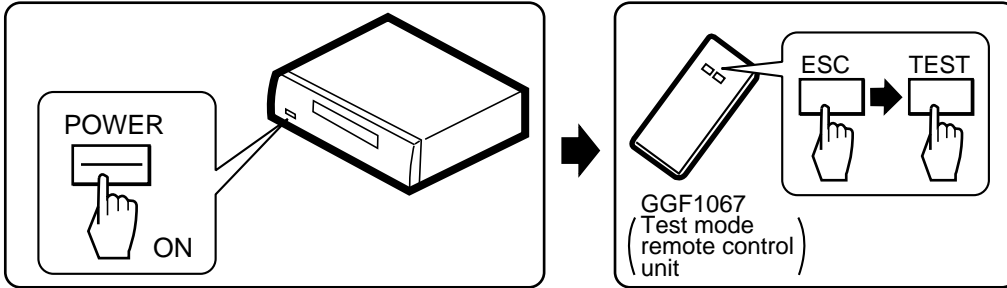

TEST MODE: DISC SET

<TRAY OPEN>

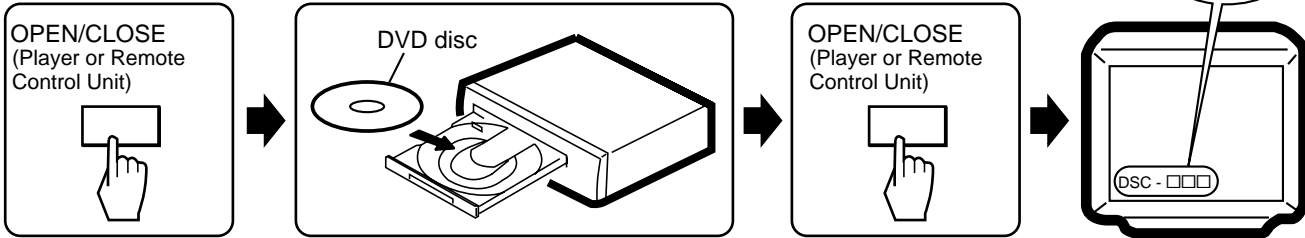

TEST MODE: PLAY

<PLAY>

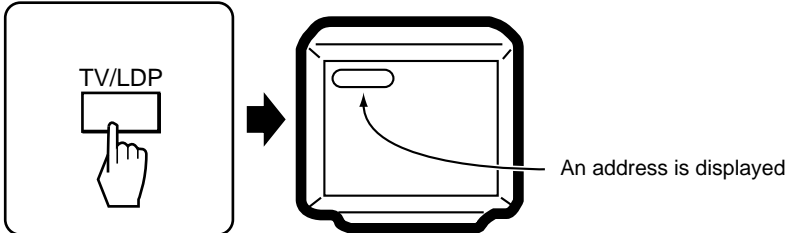

< When playback with the target address of disc (DVD)>

For example, when playback with # 30000

During PLAY **+10** → **3** → **0** → **0** → **0** → **0** → **CHP/TIM** Press keys in order

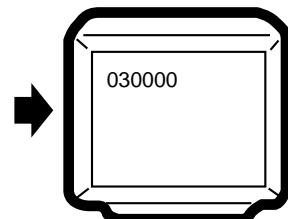

TEST MODE: OFF

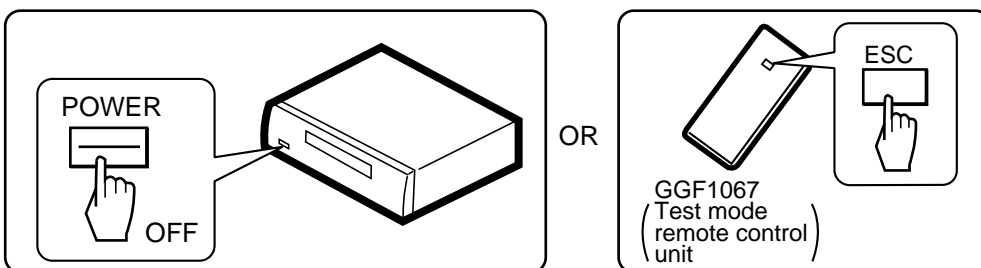

6.5 MECHANISM ADJUSTMENT

1 Tangential and Radial Height Coarse Adjustment

START

- Remove the servo mechanism.
- Remove a Spacer for height adjustment attached to the back side (shaded area) of the Servo Mechanism (Float Base) with nippers.

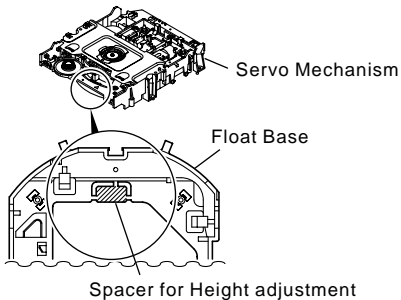

Note:
Turn the Short switch to Short side when removing the Pickup Flexible Cable. (Refer to "7.1.6 DISASSEMBLY".)



Cautions:

Because there is not a Spacer for height adjustment in adjustment after the second time, will keep it at need. (This parts is Traverse mechanism exclusive use of a model for 2001 years)



Put a spacer between a Tangential (or Radial) adjustment screw and Mechanism Base and turn each screw to adjust the height. (Refer to "6.1 ADJUSTMENT ITEMS AND LOCATION".)

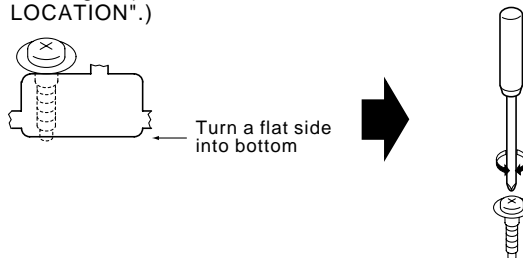

2 DVD Jitter Adjustment

- Playback method of inner and outer address for the purpose is referred to "6.4 TEST MODE".
- Jitter indication of the monitor is referred to "7.1.3 TEST MODE SCREEN DISPLAY".

Use disc: GGV1025

START

- Test mode
- Play the DVD test disc at outer track (around #200000)

Mechanism Assy

Adjust the Tangential Adjustment Screw so that jitter becomes minimum.



J4 : Min

- Play the DVD test disc at inner track (around #30000)

Mechanism Assy

Adjust the Radial Adjustment Screw so that jitter becomes minimum.



J4 : Min

- Play the DVD test disc at outer track (around #200000)

Mechanism Assy

Readjust the Tangential Adjustment Screw so that jitter becomes minimum.



J4 : Min

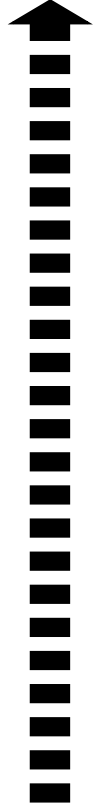
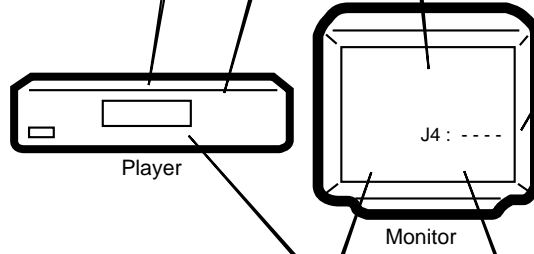

CHECK

Confirm the error rate that is displayed "OK"

(Example ER (av): $2.5e - 5 \approx \text{OK}$)

Turn the POWER OFF in case of NG once, and perform the adjustment once again.

If error rate is OK, locks a root of tangential and radial adjustment screws with the Screw tight, and go to step 3.

Screw tight : GYL1001

Disc playback normally.

- The measurement of block error rate

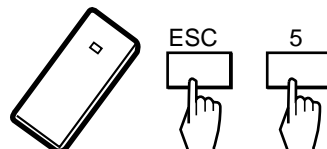

ESC 5

Test mode end

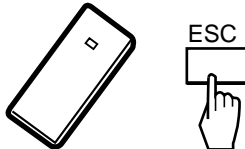

ESC

3 Initialize the Focus Sweep Setting

Purpose: To set the sweep which was correct with the individual Traverse mechanism.

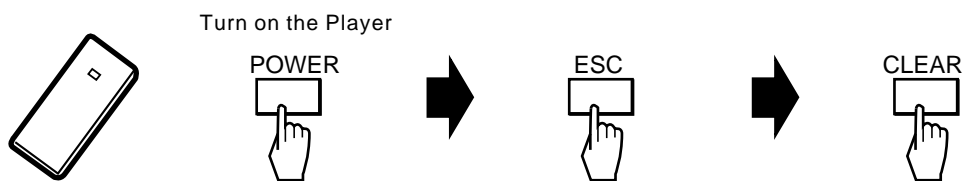

Note: Be sure to perform this step when replaced the Pickup or Traverse mechanism.

7. GENERAL INFORMATION

7.1 DIAGNOSIS

7.1.1 SELF-DIAGNOSTIC FUNCTION OF PICKUP DEFECTIVE

This unit can confirm the laser diode current value (DVD: 650nm, CD: 780nm) of pickup on the Test Mode screen.
(Press the **ESC** → **TEST** keys in order on the test mode remote control unit (GGF1067) to enter the test mode.)

It's effective in case of the following condition.

Symptom

- Indicates "No Disc" in FL display.
- Player does not playback, etc..

Procedure of Self-Diagnosis

- ① Enter the Test mode.
- ② When diagnosing the 650nm laser diode:
Press the **TEST** → **1** keys in order, and turn on the laser diode (It light-up for nine seconds.).
When diagnosing the 780nm laser diode:
Press the **TEST** → **4** keys in order, and turn on the laser diode (It light-up for nine seconds.).

When let it turn on once again after performed ② once,
After pressed **REP.B** key once
650nm: Press the **TEST** → **1** keys in order
780nm: Press the **TEST** → **4** keys in order

- ③ Confirm the indicated value of the laser diode current (LDI). (Refer to following figure.)

- ④ **When indicated value is more than 100, pickup is defective. → Replacement is necessary**
Replace the Traverse Mechanism Assy or Pickup.

Note : When a DVD disc or a CD disc is played in the test mode, this function is effective.

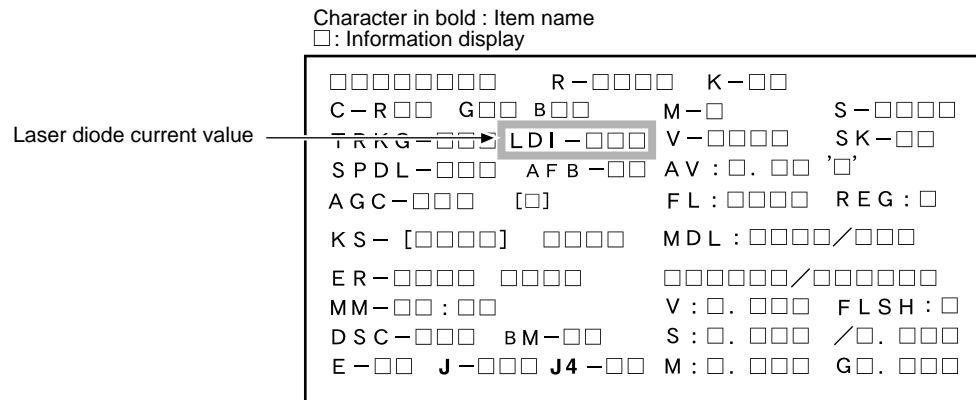

Test Mode Screen Display

7.1.2 TEST POINTS LOCATION

This model has not test terminal.
Please use following points on the DVDM Assy when checking RF, FE and TE, etc..

DVDM ASSY

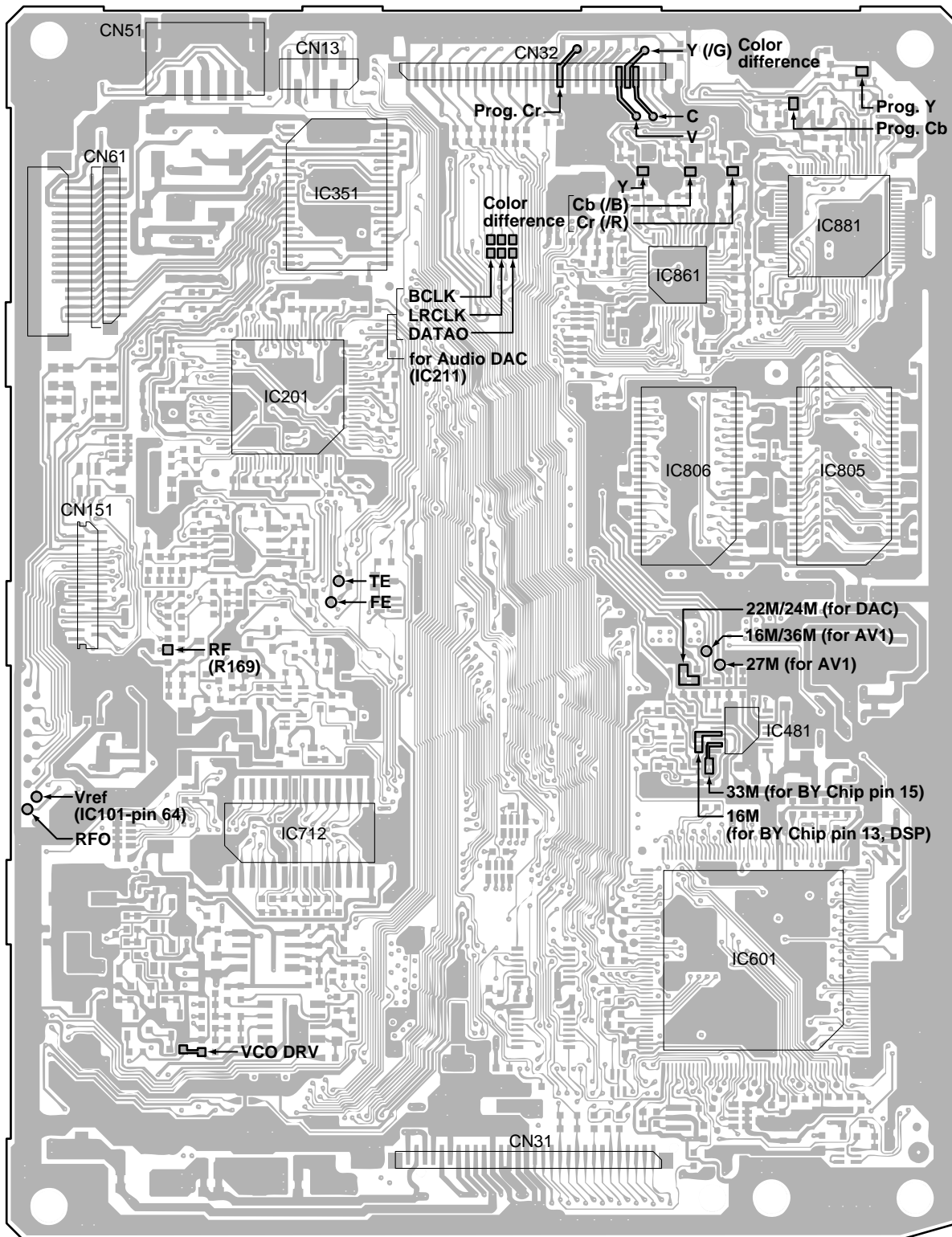

SIDE A

↓
Front Side

7.1.3 TEST MODE SCREEN DISPLAY

■ TEST MODE SCREEN DISPLAY

When the test mode is entered, press the **[ESC]** button and the **[TEST]** button in order of the test mode remote control unit (GGF1067).

Consecutive double-OSD display is supported during test mode. The screen is composed 10 lines with a maximum of 32 characters per line. It can't be used with the debugging display mode together.

• Screen Composition

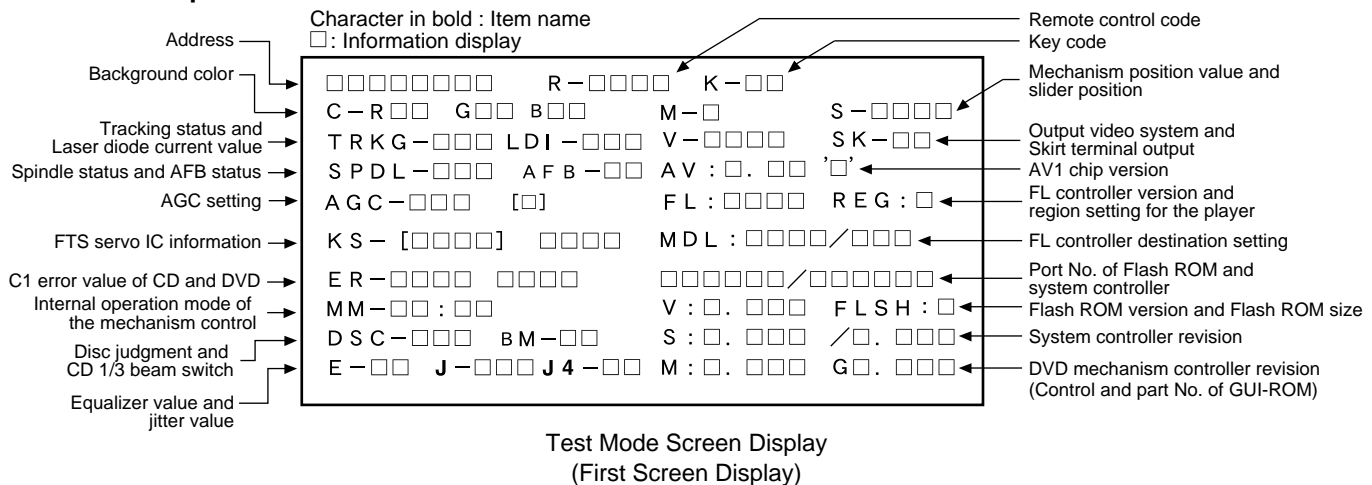

Caution :
The first screen and second screen switch by pressing [DISPLAY] key of the remote control unit.
It is only a version display part on the lower right of the screen those contents of display change.
ATB : ON/OFF information display and AGC manual setting display deleted with the second generation.
The displays of Tilt error value, Tilt servo status and pickup DVD/CLD display deleted with the third generation becomes LD part is deleted.

• Description of Each Item on the Display

(1) Address indication

The address being traced is displayed in number.
DVD : ID indication (hexadecimal number, 8 digits) [* * * * * * * *]
CD : A-TIME (min. sec.) [0 0 0 0 * * * *]
(Note : For DVDs, decimal-number indication is possible.)

(2) Code indication of the remote control unit [R - * * * *]

The code for the key pressed on the remote control unit, which is received by the FL controller, is displayed while the key is pressed. In the case of the double code, the second code will be displayed.

(3) Key code indication for the main unit [K - * * *]

The code for the key pressed on the main unit, which is received by the system controller, is displayed while the key is pressed.

(4) Background color indication [C - R * * G * * B * *]

(5) ① Tracking status [TRKG - * * *]

Tracking on [ON]
Tracking off [OFF]

② Laser diode current value [LDI - * * *]

(6) ① Spindle status [SPDL - * * *]

Spindle accelerator and brake, free-running [A/B]
FG servo [FG]
Rough, velocity phase servo [SRV]
Offset addition, rough, velocity phase servo [O_S]

② AFB status [AFB - * *]

ON [ON]
OFF [OFF]

(7) Mechanism position value [M - *]

Position code [1] to [3]

(8) Slider position [S - * * * *]

CD TOC area [IN]
CD active area [CD]

(9) AGC setting [AGC - * *]

AGC on [AGC-ON]
AGC off [AGC-OFF]

(10) Output video system [V - * * * *]

NTSC system [NTSC]
 PAL system [PAL]
 Auto-setting [AUTO]

Skirt terminal output [SK - * *]

VIDEO [00]
 S-VIDEO [01]
 RGB [02]

Note : Display only the model which can do the output setting of skirt terminal.

(11) FTS servo IC information

DSP coefficient indication [KS - [* * * *] * * * *]
 Displays the address (four digits) of the specified coefficient and the setting value (four digits) with [TEST] and [9] keys.

(12) Error rate indication

① C1 error value of CD [ER - C1 * * * *]
 ② C1 error value of DVD [ER - * * * * * * * *]

(13) Internal operation mode of mechanism controller

[MM - * * : * *]

Internal mechanism mode (2 digits) and internal mechanism step (2 digits) of the mechanism controller

(14) ① Disk sensing [DSC - * * *]

The type of discs loaded is displayed.
 [DVD], [CD], [VCD], []

② **CD 1/3 beam switch [BM - * *]**

(15) ① Equalizer value [E - * *]

② **Jitter value [J - * *]**

Make the jitter four times, and renew it in every 0.5 second. [J4 - * *]
 CD is effective only in the jitter value.

(16) Version of the AV-1 chip [AV : * . * *' *']**(17) ① Version of the FL controller [FL : * * * *]**

② **Region setting of the player [REG : *]**
 Setting value [1] to [6]

(18) Destination setting of the FL controller

[MDL : * * * * / * * * *]

Four characters in the front represent the type of model :
 three characters in the back represent the destination code.
 J : /J, K : /KU, /KC, /KU/KC, R : /RAM, /RL, /RD, /LB,
 WY : /WY

(19) The part number of the flash ROM and system controller [* * * * * * / * * * * * * * *]

① Part number of the flash ROM <Front>
 (Example) VYW1536-A = W1536A
 (Example) PD6256A9 = 6256A9
 ② Part number of the system controller <Back>
 (Example) PD3381T1 = 3381T1

(20) ① Version of the flash ROM [V : * . * * *]

② **Flash ROM size [FLSH = *]**

(21) Revision of the system controller [S : * . * * * / * . * * *]

① Revision number of the external ROM part (flash ROM) of the system controller <Front>
 ② Revision of the internal ROM part of the system controller <Back>

(22) Revision of the DVD mechanism controller

[M : * . * * *]

Revision number of the external ROM part (flash ROM) of the DVD mechanism controller

(23) Control and part numbers of the GUI-ROM

[GUI : * * * *]

No GUI model displays as "— / —".

OEM model displays the part number of GUI-ROM
 [GUI : * * * *]

■ DEBUGGING SCREEN SPECIFICATION FOR THE MECHANISM CONTROLLER

• This specifications is subject to change without notice.

① Indication Method of The Mechanism Controller Debugging Screen

A debugging screen of the mechanism controller is indicated when pressing the test mode remote control unit [GGF1067] in order of the **[ESC]** and **[CHP/TM]** buttons.

Release from debugging screen display of the mechanism controller with the **[ESC]** button.

② Screen Layout

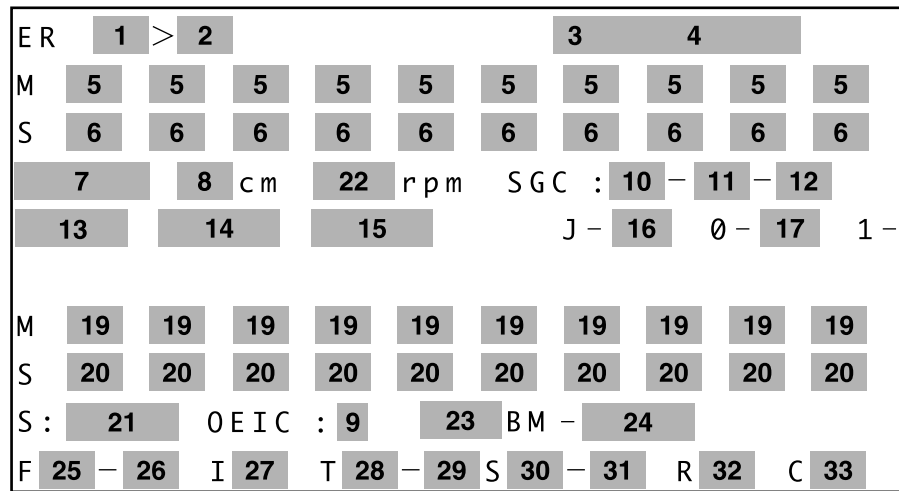

③ Indication Contents

- The error that became the trigger that an error of 2 occurred.
There are many cases same as 2.
- The error number that transferred to the system controller
Refer to the error list about contents of error number.
- Code read in state (it does not support in this unit)
When X is indicated, ID or subcode are not able to read in.
When X is not indicated, they are able to read in.
- ID or subcode (it does not support in this unit)
Subcode indicates the A time.
- Inside mode of the mechanism controller when an error of 1 occurred
It can indicate to a maximum 10 mode. Indicate it in order of an old mode from the left, and go right, and become a new mode. Indicate only a nest share of the mode.
- Processing step of inside mode of 5
It can grasp the mode reaching an error and transition of step by watching 5 and 6 and it can specify the occurrence place of most errors.
- Disk information in the mechanism controller
? : Indistinctness
NO : There is no disc
DVD 1 : DVD single layer
DVD 2 : DVD dual layer
CD : CD
CDR : CD-R or CD-RW
CDR P : PRD of CD-R or CD-RW
- As a result of 8cm /12cm distinction
? : Indistinctness (undistinction)
8 : 8 cm
12 : 12 cm
- OEIC gain (it does not support in this unit)
H : OEIC HIGH gain
L : OEIC LOW gain
- SGC gain for LD of 780nm
It indicates a step using in the mechanism controller inside with a hexadecimal number.
Set the gain so that S curve becomes 1.8V (p-p) in disc distinction.
- SGC gain for LD of 650nm For L0.
It indicates a step using in the mechanism controller inside with a hexadecimal number. Set a gain so that S curve becomes 1.8V (p-p) in disc distinction.
- SGC gain for LD of 650nm For L1.
It indicates a step using in the mechanism controller inside with a hexadecimal number. Set a gain so that a S curve becomes 1.8V (p-p) in disc distinction.
- RF count value for disc distinction
RF count value to use the disc distinction. It compares threshold value of 14 and 15 and distinguishes the disc.
- Disc distinction threshold value (DVD and CD)
Threshold value of the disc distinction. Distinguish it from DVD if bigger than this value, and distinguish it from CD if small.

15. Disc distinction threshold value (CD and unrecorded disc)
Threshold value of the disc distinction. Distinguish it from CD if bigger than this value, and distinguish it from an unrecorded disc if small.
16. Current jitter value
Indicate the value that was read in from the BY-CHIP (IC701) in DVD, and indicate the value that was read in from the servo DSP in CD.
17. Focus balance setting value of L0
18. Focus balance setting value of L1
19. Current mechanism controller inside mode
(it does not support in this unit)
It can indicate to a maximum 10 modes. Indicate only a nest share of the mode.
20. Processing step of 11 inside modes
(it does not support in this unit)
It can grasp the current mode, the mode reaching it and transition of step by watching 19 and 20.
21. Spindle control state of BY-CHIP (IC701)
(it does not support in this unit)
OFF : Motor off condition
A/B : Accelerator and brakes
FG : FG servo
RVP : Rough speed phase servo
ORVP : Rough speed phase servo of offset addition
22. Rotation number of spindle motor
Do not FG read in ? indication (during spindle stop).
23. Tracking error generation system
(it does not support in this unit)
1: 1 beam (DPD)
3: 3 beams
24. TZC count value (it does not support in this unit)
The value that counted the number of TZC for one rotation in the tracking open state.
When this value is more than 512 with CD, set it in 1 beam because the eccentric is large.
DVD does not measure it because it is 1 beam fixed (indication is 0000).
25. It indicates the frequency that entered the focus backup
Hexadecimal number indication. Counter does not reset till turns the power off after turning it on. Due to a 1 byte counter, next of FF becomes 00.
26. It indicates focus backup limit frequency with the hexadecimal number
Initial value is 14H, it does decrement whenever enter the focus backup and it gives up backup if it became 0. Then the error is generated. After reverted from the backup, When not enter the backup and pass fixed time (1500ms), return to initial value again.
27. It indicates the frequency that entered the internal circumference plunging into backup of the sled
Hexadecimal number indication. Counter does not reset till turns the power off after turning it on. Due to a 1 byte counter, next of FF becomes 00.
28. It indicates the frequency that entered the tracking overrun backup
Hexadecimal number indication. Counter does not reset till turns the power off after turning it on. Due to a 1 byte counter, next of FF becomes 00.
29. It indicates the limit frequency of tracking overrun backup with a hexadecimal number
Initial value is 03H, it does decrement whenever enter the tracking overrun backup and it gives up backup if it became 0.
30. It indicates the frequency that entered sled overrun backup
Hexadecimal number indication. Counter does not reset till turns the power off after turning it on. Due to a 1 byte counter, next of FF becomes 00.
31. It indicates the limit frequency of sled overrun backup with a hexadecimal number
Initial value is 03H, it does decrement whenever enter the sled overrun backup and it gives up backup if it became 0.
32. It indicates the frequency that entered the tracking close NG backup
Hexadecimal number indication. Counter does not reset till turns the power off after turning it on. Next of FF is be a 1 byte counter in 00.
The hexadecimal number indication which indicates the frequency that reads
33. ID/subQ, and entered NG backup
Hexadecimal number indication. A counter does not reset it till cuts it off after turning it on. Due to a 1 byte counter, next of FF becomes 00.
34. An address to indicate in 35
Set it by using RS232.1
(an address) Set it with DA.
35. Contents of an address indicated in 34.

7.1.4 TROUBLE SHOOTING

- No Power ON
- FL is not turned ON
- FL indication is unusual

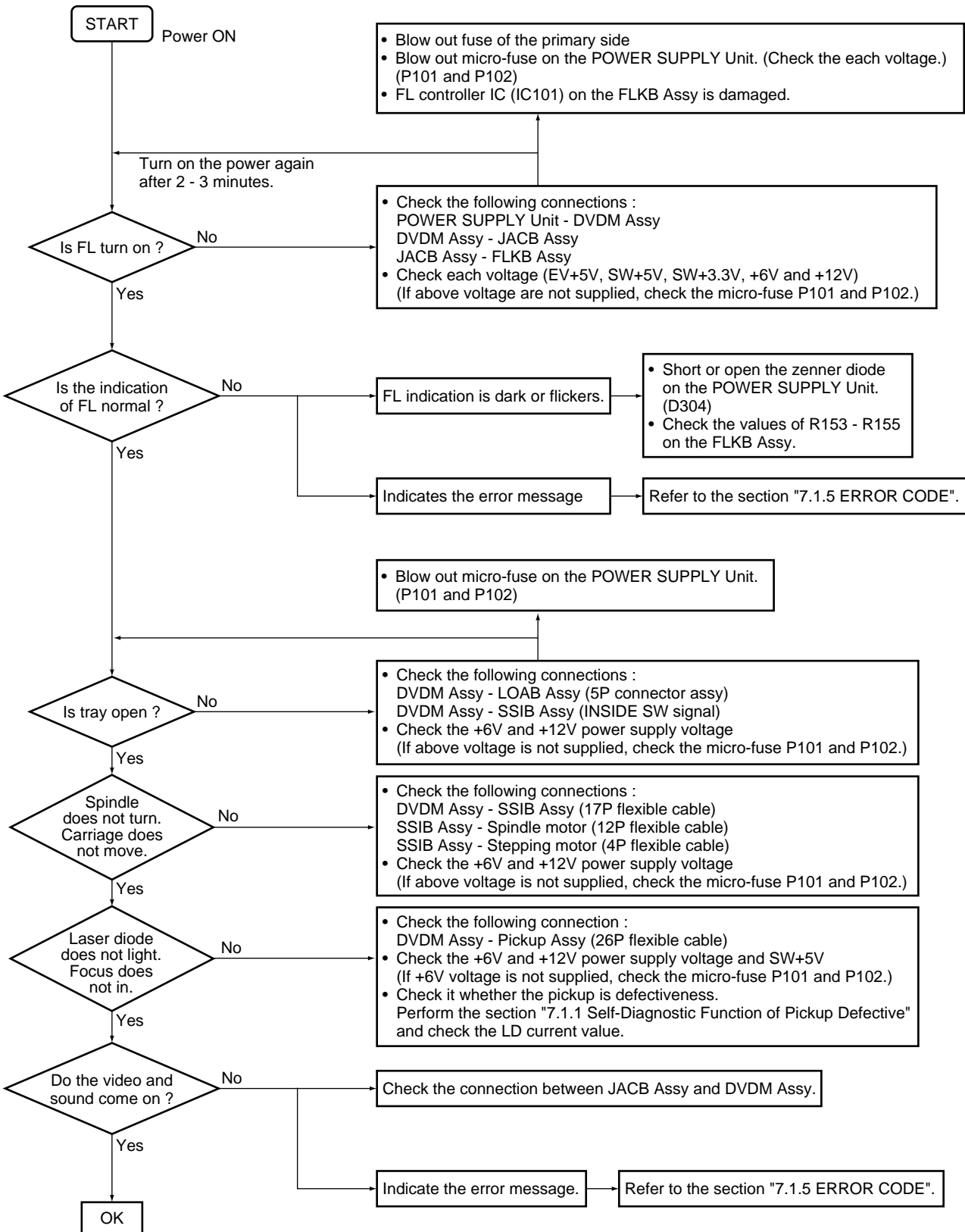

7.1.5 ERROR CODE

Error codes that are displayed on the FL display without using the remote control unit

FL Display	Possible causes	Operation of the unit
AV1 VER	AV-1 chip is not a match with the program of system controller	The sound may not out with the specific audio.
CPU AERR	CPU address error (Hardware is unusual.)	No operation
DMA AERR	DMA address error (Hardware is unusual.)	No operation
FLASH ID	Difference in versions of the internal ROM of the system controller and of the flash ROM, or bus line failure or reverse installation	No operation
FLASH WRP	Write protect error of the flash ROM	No operation
FLASH SIG	Difference in part number of the flash ROM (When the ROM which could't be used was used.)	No operation
FLASH SUM	Check sum error of the flash ROM (It exceeds the regular size.) or reverse installation (Hardware is unusual.)	No operation
FLASH SIZE	Size error of the flash ROM (Use 4 or 8 M-bit.)	No operation
ILLGAL	The system controller fetched a code other than an operation code (Hardware is unusual.)	No operation
RESERVE	Undefined interrupt (Hardware is unusual.)	No operation
SLOT	Inappropriate slot command issued (Hardware is unusual.)	No operation
SDSP PWER	Access error to the servo DSP or clock does not oscillation (Hardware is unusual.)	Accept only OFF operation of the POWER key of the main unit. Remote control unit is impossible.

Error codes that are displayed on the FL display by using the remote control unit (Mechanism controller error)

To display: ESC + DISPLAY + DISPLAY; Location of the display: At the two digits of center of the FL display

To display the error history: ESC + DISPLAY + One shot; Location of the display: TV screen

FL	Description of Error	Causes if with a DVD	Causes if with a CD	Operation of the Unit
11	Search timeout	Search could not be complete within 7 seconds.	Search could not be complete within 7 seconds, and it could not enter the target area within 7 seconds by VCD scan.	CD : Stops, DVD : Continues operation
12	Search retry error	A search could not be completed after 3 retries, search backup was executed 4 times, or in a case of timeout (6 seconds) while the unit was tracing 11 tracks or more beyond the target while the search operation was converging.	Backup against slider skip was executed 4 times during a search, or slider skip twice resulted in starting from the read-in point.	CD : Stops, DVD : Continues operation
19	Tracing timeout while converging	Timeout (10.5 seconds) while tracing at the stage of convergence of a search.		Stop
1B	Index 0 search error		During Track (Index) Search, the search for the beginning of a program could not be completed within 3 seconds (20 seconds in the case of Index Search) after positioning based on the TOC data was completed.	Stop
1C	Wobble distinction error	Distinguished RW disc without wobble.		Read the RW control data.
22	Timeout of slider inner circumference	Inside switch could not ON within 3 seconds.		Stop
23	Timeout of slider outer circumference	Inside switch could not OFF within 2 seconds.		Stop

FL	Description of Error	Causes if with a DVD	Causes if with a CD	Operation of the Unit
33	No FOK pulse during playback CLVA	When the focus was deviated continuously 20 times.		Adjusts focus at the innermost circumference and tries to return to its position where the error was generated (for 3 times), then opens. If the same error persists after one retry, the tray opens. (No FOK pulse)
38	Disc-type-sensing error	If normal starting was impossible in the following three cases, disc-type sensing will be retried if other errors occur excepting C5 error. However, when the focus error "33" was occurred continuously 3 times, it is finished as "38 error" at the moment: (1) startup with the first disc-type-sensing result, (2) forced startup with another disc by designating the disc type, (3) forced startup with the original disc by designating the disc type.		Open
39	SGC converge timeout	SGC could not converge during detects the peak		Open
41	Spindle timeout	The unit did not enter Stop mode within 10 seconds of issuance of a Stop command.		Stop
48	Spindle FG transition timeout	The spindle could not converge into within $\pm 12\%$ of the target FG rotation speed within 10 seconds after spindle kick. The first time after startup (the first time after disc distinction), it doesn't become the number of the target rotation within five seconds. The first time after startup, detects the abnormal rotation number of high-speed continuously 3 loops. DVD: 5 to 9 mS, CD: 40 to 60 mS		Stops. (FG timeout)
49	Spindle PLL transition timeout	After the second times after startup, it doesn't become the number of the target rotation within five seconds. Detects the abnormal high-speed or low-speed rotations. DVD: 5 to 9 mS, CD: 40 to 60 mS		Stops. ("73" is displayed during starting process.)
4A	Spindle lock timeout	Spindle could not lock more than 1.5 seconds before start the AFB.		Stops. ("73" is displayed during starting process.)
51	Auto sequence timeout of peak detection	ABUSY did not return within 1 second after the DDTCT (peak detection) command was sent.		Stop
52	Auto sequence timeout of focus jump down	ABUSY did not return within 30 mS after the FJMPD (Focus jump 1 to 0) command was sent.		Stop
53	Auto sequence timeout of focus jump up	ABUSY did not return within 30 mS after the FJMPU (Focus jump 0 to 1) command was sent.		Stop
54	Auto sequence timeout of play AGC	ABUSY did not return within 50 mS after the GSUMON (play-AGC-measuring) command was sent.		Stop
55	Auto sequence timeout of disc-type-sensing	ABUSY did not return within 2 seconds after the DJSRT (disc-sensing) command was sent.		Stop
56	Auto sequence timeout of ATB2	ABUSY did not return within 1 second after the TBLOFS (Internal ATB after the completion of external ATB) command was sent.		Stop
57	Auto sequence timeout of tracking servo ON	ABUSY did not return within 500 mS after the TSON (tracking servo ON) command was sent.		Stop
58	Auto sequence timeout of ATB1	ABUSY did not return within 200 mS after the TBL (external ATB) command was sent.		Stop
59	Auto sequence timeout of focus gain adjustment	ABUSY did not return within 2 seconds after the FGN (focus gain adjustment) command was sent.		Stop
5A	Auto sequence timeout of tracking gain adjustment	ABUSY did not return within 2 seconds after TGN (tracking gain adjustment) command was sent.		Stop
5B	Auto sequence timeout of offset adjustment	ABUSY did not return within 1 second after the CMDAVE (offset adjustment) command was sent.		Stop

FL	Description of Error	Causes if with a DVD	Causes if with a CD	Operation of the Unit
5C	Auto sequence timeout of modulation factor measurement	ABUSY did not return within 200 mS after the ADJMIR (modulation factor measurement) command was sent.		Stop
5D	Auto sequence timeout of auto focus bias	ABUSY did not return within 2 seconds after the AFB (auto focus bias) command was sent.		Stop
5F	Auto sequence already busy	A command could not be sent because ABUSY was low. ABUSY did not return within 200 mS after TLV command was sent.		Stop
62	Pause retry error	Pause mode could not be restored within three retries after it had been released.		Continues operation
71	ID can not read during tracing	An ID could not be read for 1 second or more.		Stop
72	Subcode check failure during playback		No frame could be read for 3 seconds or more.	Stop
73	ID can not read at the startup	An ID could not be read within 1 second after the AFB adjustment had been finished.		Opens (ID readout failure)
74	Subcode check failure during startup		No subcode could be read within 3 seconds after AFB adjustment had been finished.	Opens (Subcode readout failure).
81	Timeout for reading TOC of the mechanism controller		TOC readout took 30 seconds or more.	Stop
82	Timeout for reading TOC of the system controller		Reading TOC of the system controller took 30 seconds or more.	Stop
A1	Communication timeout of DSP command	A command could not be issued to DSP because Command Busy (XCBUSY) was in force (XCBUSY = L) for a specified time (about 200 mS).		Open
A2	Communication timeout for reading DSP coefficient	Command Busy (XCBUSY) was in force for a specified time (about 200 mS) before and after a coefficient read command was issued to DSP, or the address echo-back after command issuance did not match the setup address.		Open
A3	Communication timeout for writing DSP coefficient	Command Busy (XCBUSY) was in force for a specified time (about 1024 mS) before and after the coefficient write command was issued to DSP.		Open
A4	Communication timeout for continuously writing DSP coefficient	Command Busy (XCBUSY) was in force for 200 μ S during continuous coefficient writing, or before and after a continuous write command was issued to DSP.		Open
B1	Timeout error for backup	In the tracing state during the backup sequence, codes could not be read for 1 second or more. In the backup sequence, tracking ON sequence of the servo DSP could not be completed even if more than 500 mS after the tracking ON command was issued.		Stops
B2	Retry error for backup	Tracing impossible after retring the tracking ON for 3 times in the backup sequence.		Stops
B3	Retry error for trace	During tracing, runaway was detected after three iterations of backup operations for detecting runaway.		Stops
C3	Detection of tracking overcurrent	During playback, the overcurrent detection port was at L for 300 ms or more continuously.		Stops (the mechanical controller operates independently).
(C5)	Short-circuit test corresponding error	While the power was on, the overcurrent detection port was at L for 40 ms or more continuously.		Turns off the power instantly (No indication on the FL display and no writing to flash memory)
E3	Violation against digital copy guard			Stops

DV-444, DV-440

FL	Description of Error	Causes if with a DVD	Causes if with a CD	Operation of the Unit
F5	Tray being pushed	The tray switch that had been Open mode was forcibly changed to a mode other than Open by an external force.		Closes
F8	Loading timeout	Loading, unloading or clamping could not be completed within a specified time (about 5 seconds).		Reverses the loading direction. If timeout is repeated upon retry, the unit stops.
FC	Focus	<p>The following error occurred eight times.</p> <p>(1) Focus ON sequence could not be completed even if more than two seconds after the focus ON command (to the servo DSP) was sent.</p> <p>(2) Focus IN sequence was finished, actually focus IN was not completed.</p>		Stops wherever possible then opens (stops in the case of side B).

Error codes that are displayed on the FL display by using the remote control unit (Device error)
To display : ESC + DISPLAY + DISPLAY ; Location of the display : At the two digits of left of the FL display

FL	Description of Error	Causes if with a DVD	Causes if with a CD	Operation of the Unit
bit3=1 08 etc.	AV1 access error (read, write NG)			No operation or it becomes debugging indication if the power is able to ON.
bit2=1 04 etc.	MY CHIP access error			
bit1=1 01 etc.	SRAM access error			

7.1.6 DISASSEMBLY

DIAGNOSIS OF PCBs

Note

When diagnosing the unit, be sure to use two connection cables for service. (Part No. : GGD1222)

1 Bonnet and Tray Panel

- ① Remove the Bonnet (Screws × 6)
- ② Power ON
- ③ Tray open (▲)
- ④ Remove the Tray Panel

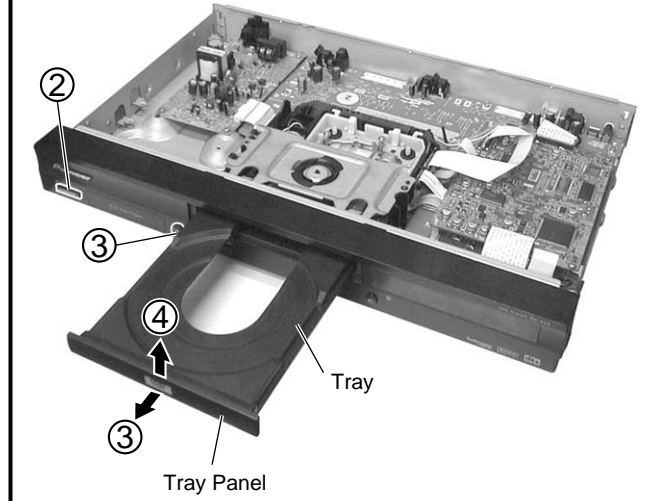

How to Open the Tray by Manual Operating

In the reverse state, pass a small screwdriver through a slit and slide a protruding portion of the Drive Gear of the Loading Mechanism Assy to the direction of arrow.
If the Tray moved toward the front about 2 or 3 cm, pull out the Tray by hands.

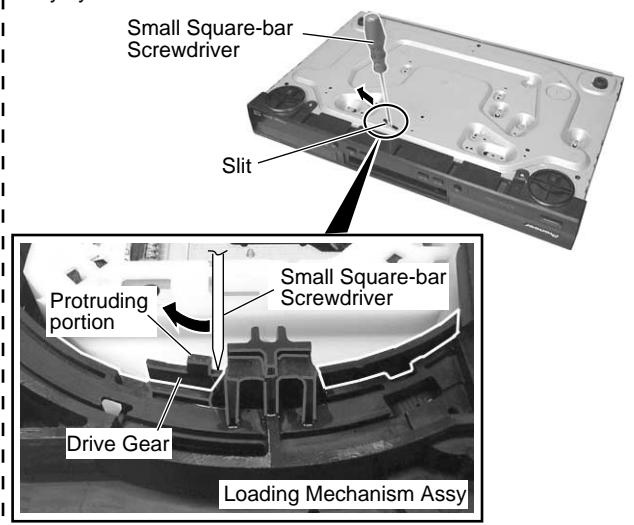

2 Test Disc Set

- ① Set the Test Disc
- ② Tray close (▲) → Clamp the Test Disc
- ③ Power OFF
- ④ Pull out the Power Cord from the outlet

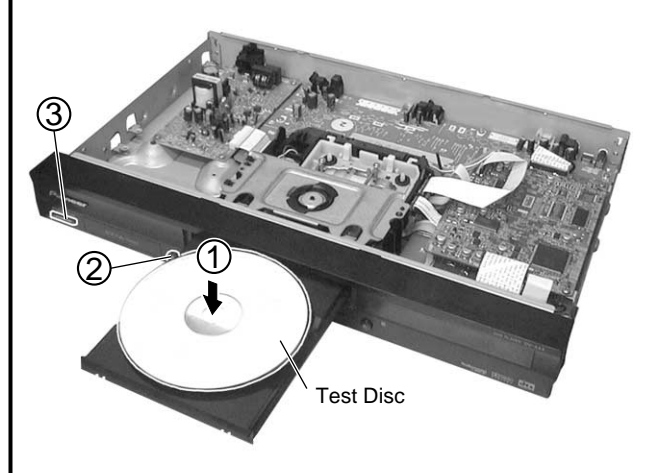

3 Front Panel Assy

- ① Unhook (×6)
- ② Remove the Front Panel

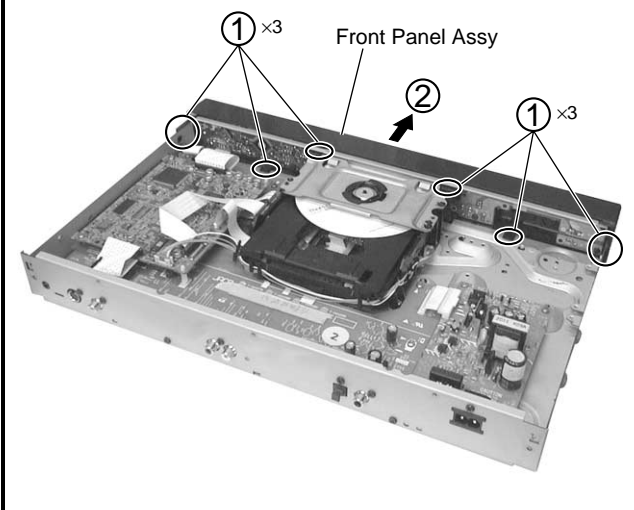

● PCB Location

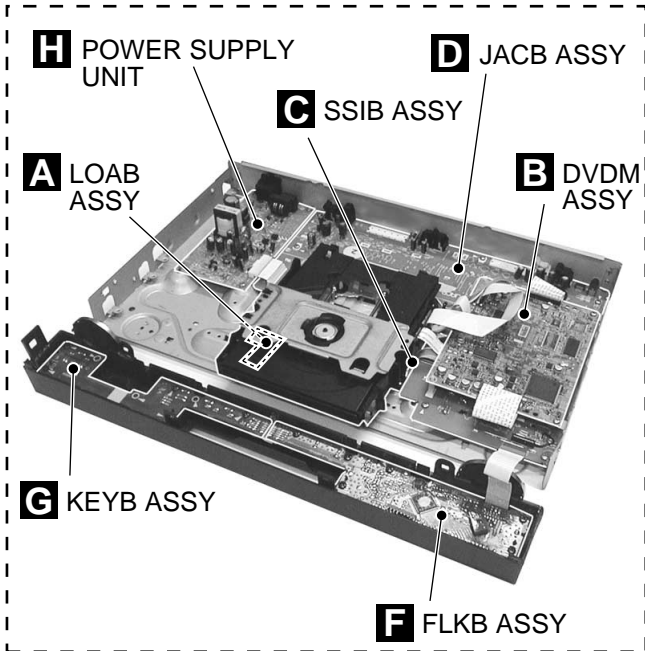

4 Loading Mechanism Assy

- ① Remove four screws.
- ② Remove the Loading Mechanism Assy.

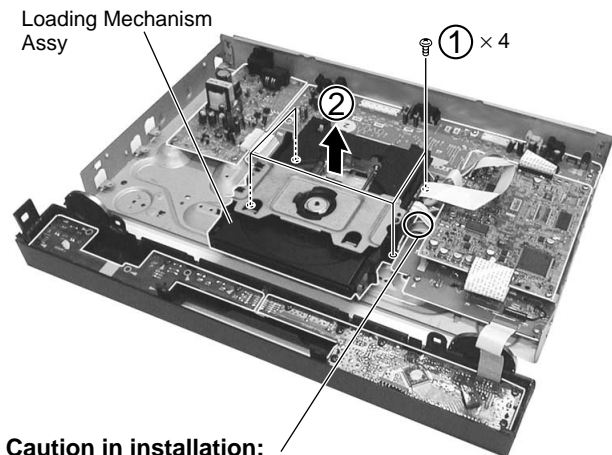

Caution in installation:

Excess length of 4P Flexible Cable of the stepping motor performs styling not to hold it under the JACB Assy.

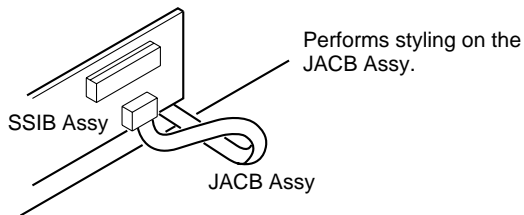

5 Diagnosis of DVDM Assy

- ① Remove two screws.
- ② Remove two PCB Support.
- ③ Remove two Flexible Cable.
- ④ Remove the DVDM Assy.

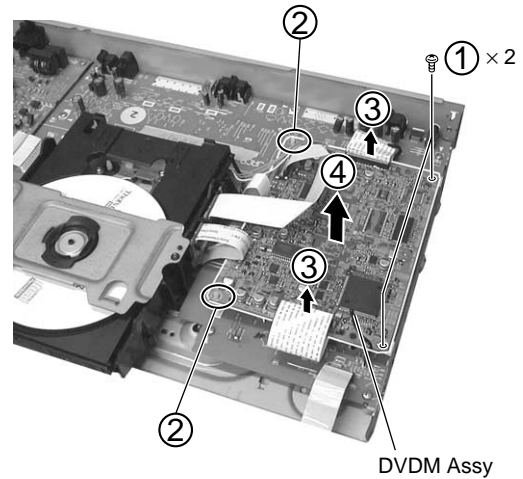

- ⑤ Connect two Connection Cables for Service (GGD1222) between DVDM Assy and JACB Assy.
- ⑥ Reverse the Loading Mechanism Assy and DVDM Assy, and arrange as figure below.
- ⑦ Put in spacers under the Loading Mechanism Assy not to rub the Clamper.

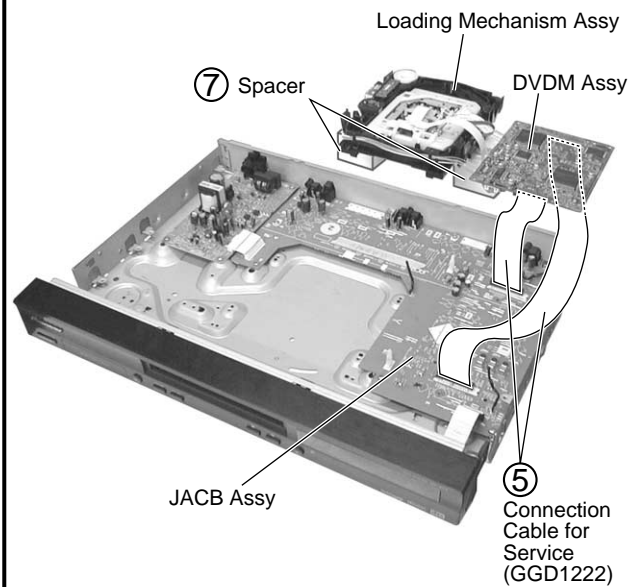

- ⑧ Playback with a test disc, and diagnose the DVDM Assy.

6 Diagnosis of JACB Assy

- ① Remove the Rear Panel (Screws ×7).
- ② Remove the JACB Assy, MJKB Assy and the POWER SUPPLY Unit (Screws ×10)(PCB Support ×1).
- ③ Connect two Connection Cables for Service (GGD1222) between DVDM Assy and JACB Assy.
- ④ Short-circuit W284 (GND of audio and video) on the JACB Assy as shown in the right figure. (Audio does not come out from output terminal that does not short-circuit.)
Note: If diagnosis was completed, be sure to remove a wire.
- ⑤ Reverse the JACB Assy and POWER SUPPLY Unit, and arrange as figure below.

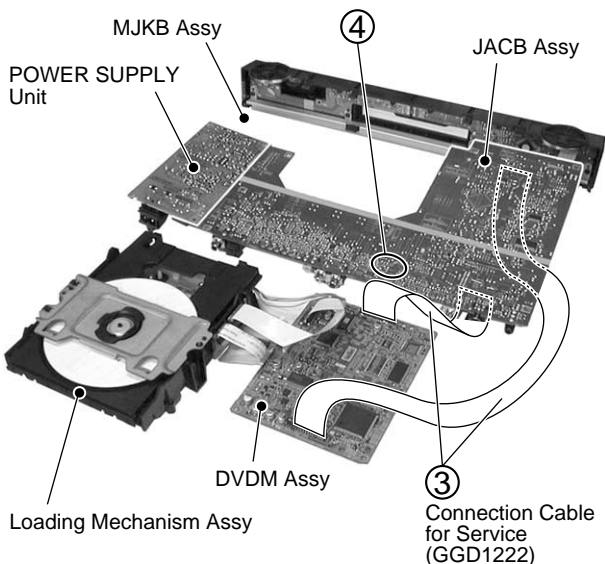

- ⑥ Playback with a test disc, and diagnose the JACB Assy.

● Short point of the JACB Assy

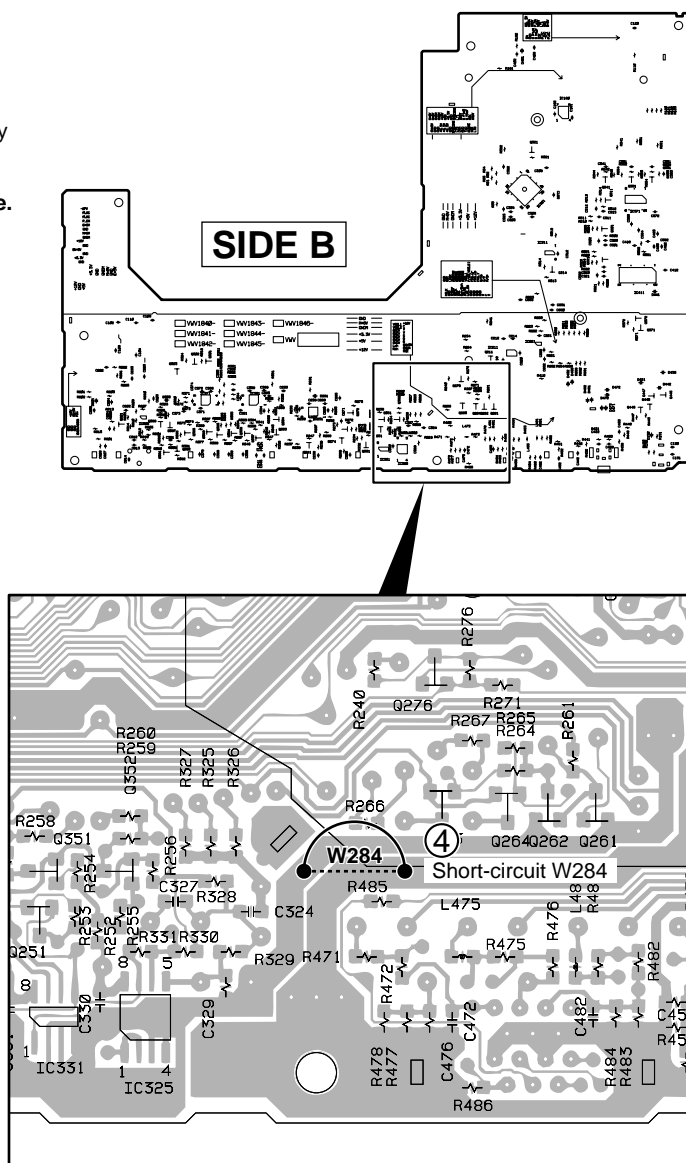

Disassembly of the Traverse Mechanism Assy and the Pickup Assy

- ① Remove the Bonnet and Tray Panel.
- ② Remove the Front Panel.
- ③ Remove the Bridge (Screw ×1).
- ④ Pull out the Tray and remove it while unhooking a Hook.
- ⑤ Turn the Short SW to Short side.
- ⑥ Remove three connectors.

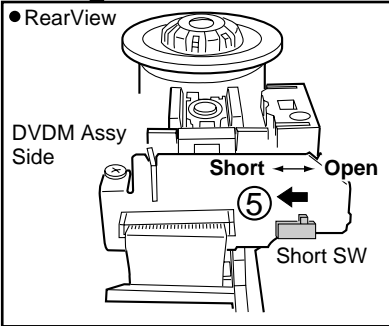
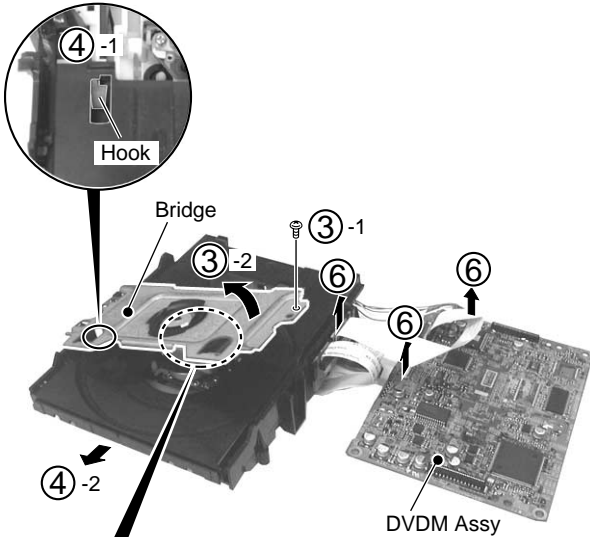

Caution in the tray insertion

In the Tray insertion, insert it after matching a triangle mark of the Loading Base and a position of pin of the Drive Cam.

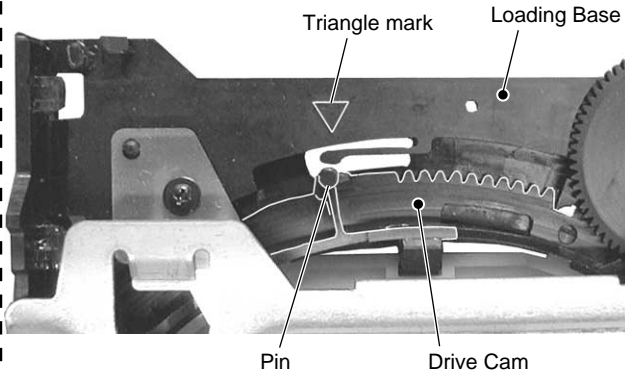

- ⑦ Remove the Loading Mechanism Assy (Screws ×4).
- ⑧ Remove a screw.

Cautions:
Screw is locked with Silicone Adhesive.
Please lock it with Silicone Adhesive when installs it.

- ⑨ Remove the FFC Holder with the state which Flexible Cable was attached.

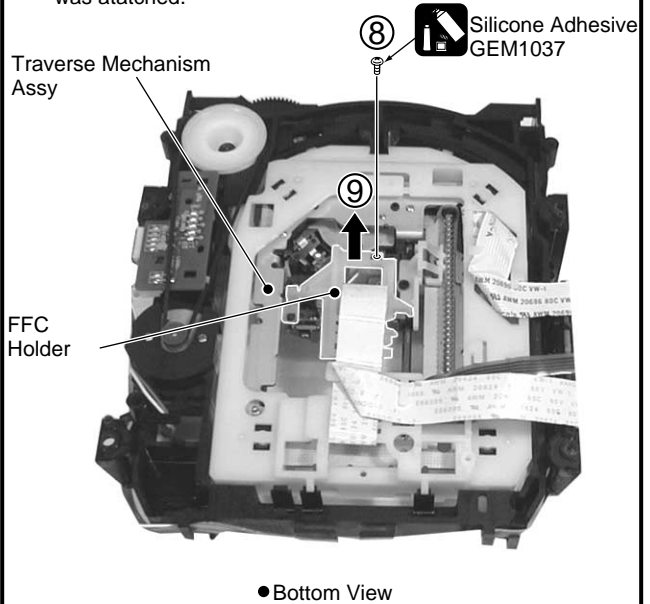

Pickup Assy

When Removing The Traverse Mechanism Assy

- ⑩ Remove the Pickup Flexible Cable
- ⑪ Unhook (×4)
- ⑫ Remove the Traverse Mechanism Assy

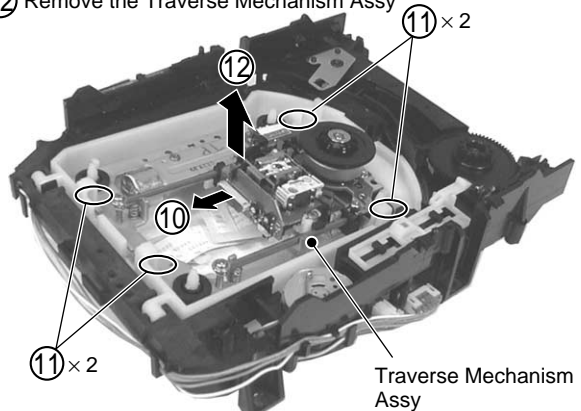

Exchange



● When Removing The Pickup Assy

⑩ Remove the Pickup Flexible Cable.

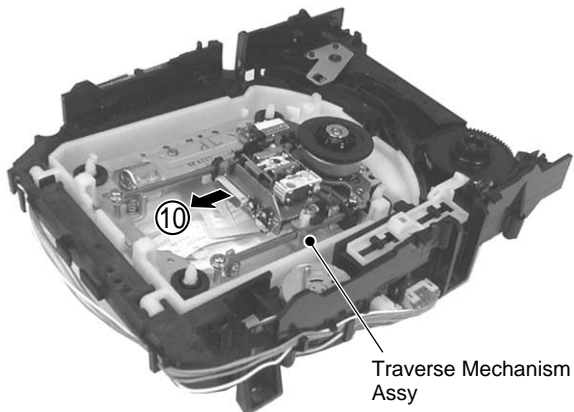

⑪ Remove two Skew Screws and two Skew Springs.

⑫ Remove the Pickup Assy.

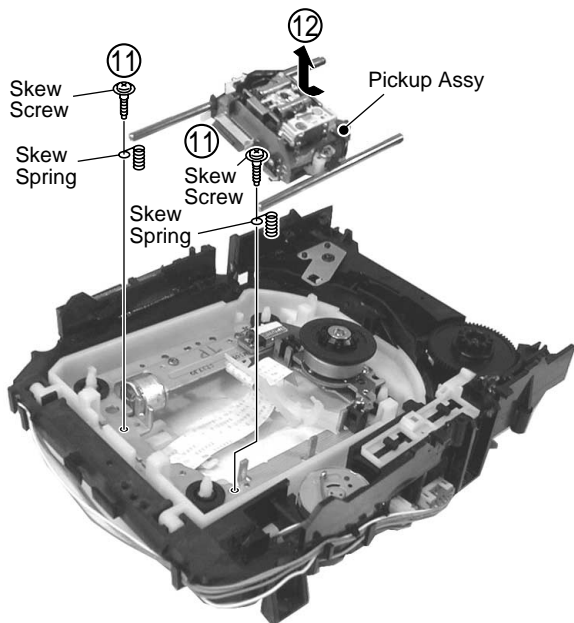

⑬ Remove two screws.

Cautions:

Screw is locked with Silicone Bond.
Please lock it with Silicone Bond when installs it.

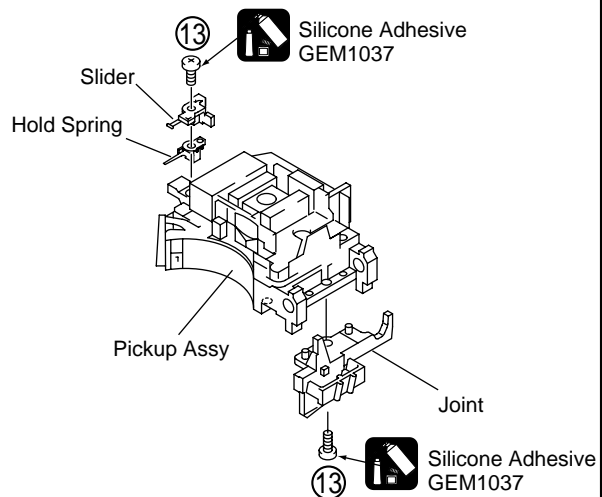

Exchange

Styling the Pickup Flexible Cable

- ① Fold a edge of lining part of the Pickup Flexible Cable.
- ② Insert the Pickup Flexible Cable in connector, and lock it surely.

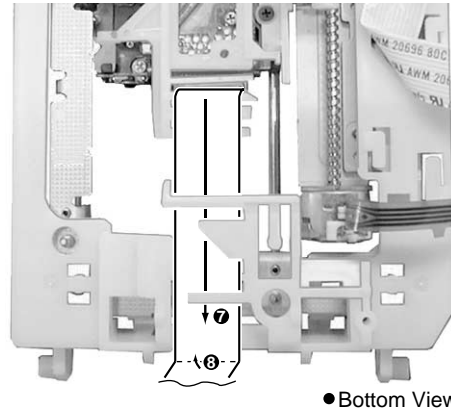
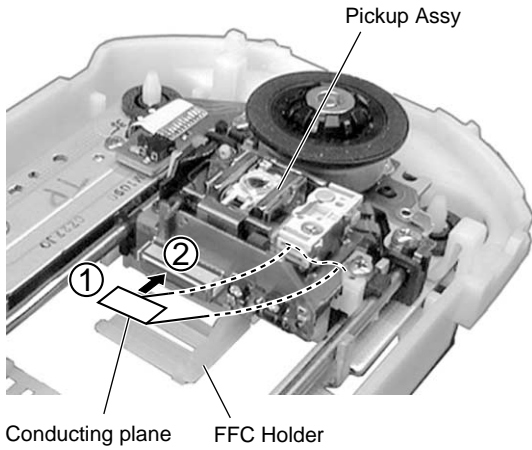

●Bottom View

Caution:
Move the Pickup to the innermost of the disc.



- ③ Perform the styling as shown in figure below.

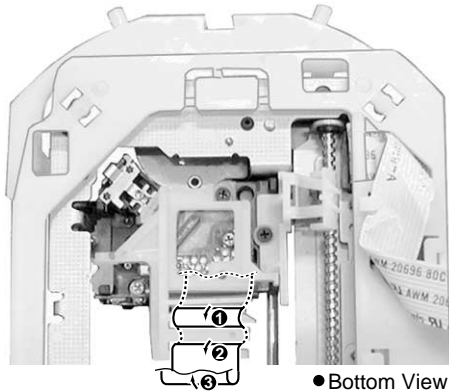

●Bottom View

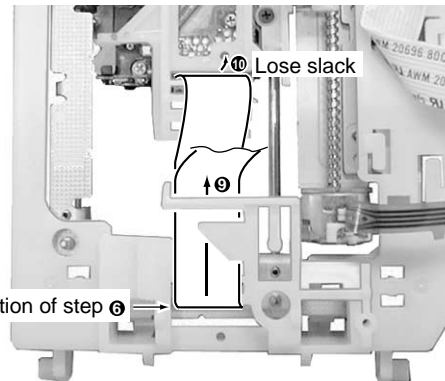

●Bottom View



Fold it at the position of reference line.

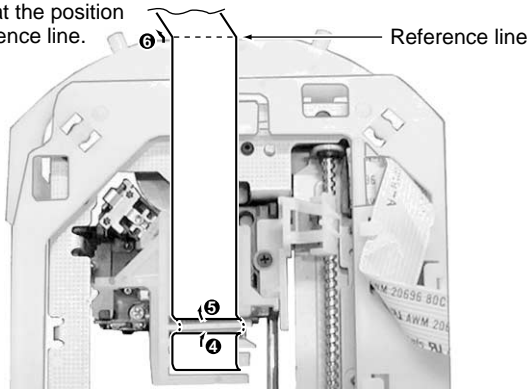

●Bottom View

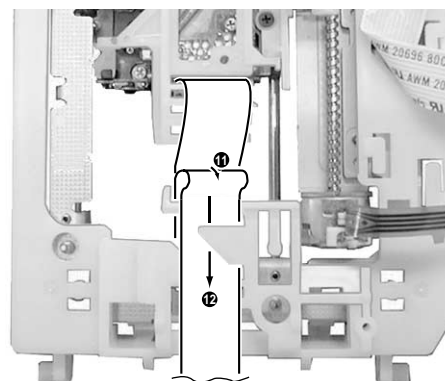

●Bottom View

7.2 PARTS

7.2.1 IC

• The information shown in the list is basic information and may not correspond exactly to that shown in the schematic diagrams.

• **List of IC**

LA9701M, LC78652W, BA6664FM, PD6345A, M65774BFP, ADV7172KST, PM0026A, PCM1742KE, MM1540BF, MM1540CF, PE5251A

■ **LA9701M (DVDM ASSY : IC101)**

• **RF IC**

• **Block Diagram**

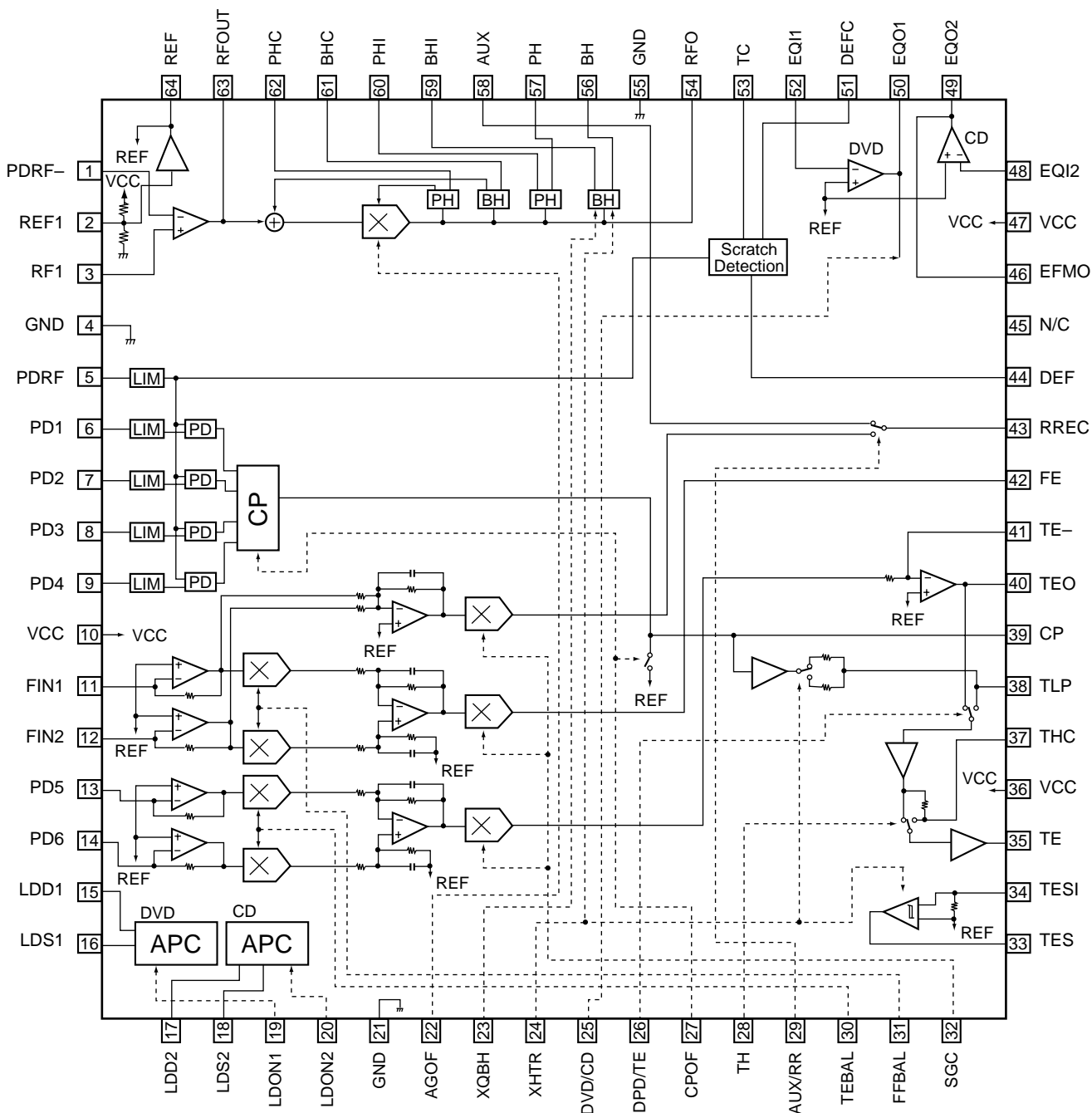

■ LC78652W (DVDM ASSY : IC201)

• Servo DSP IC

● Block Diagram

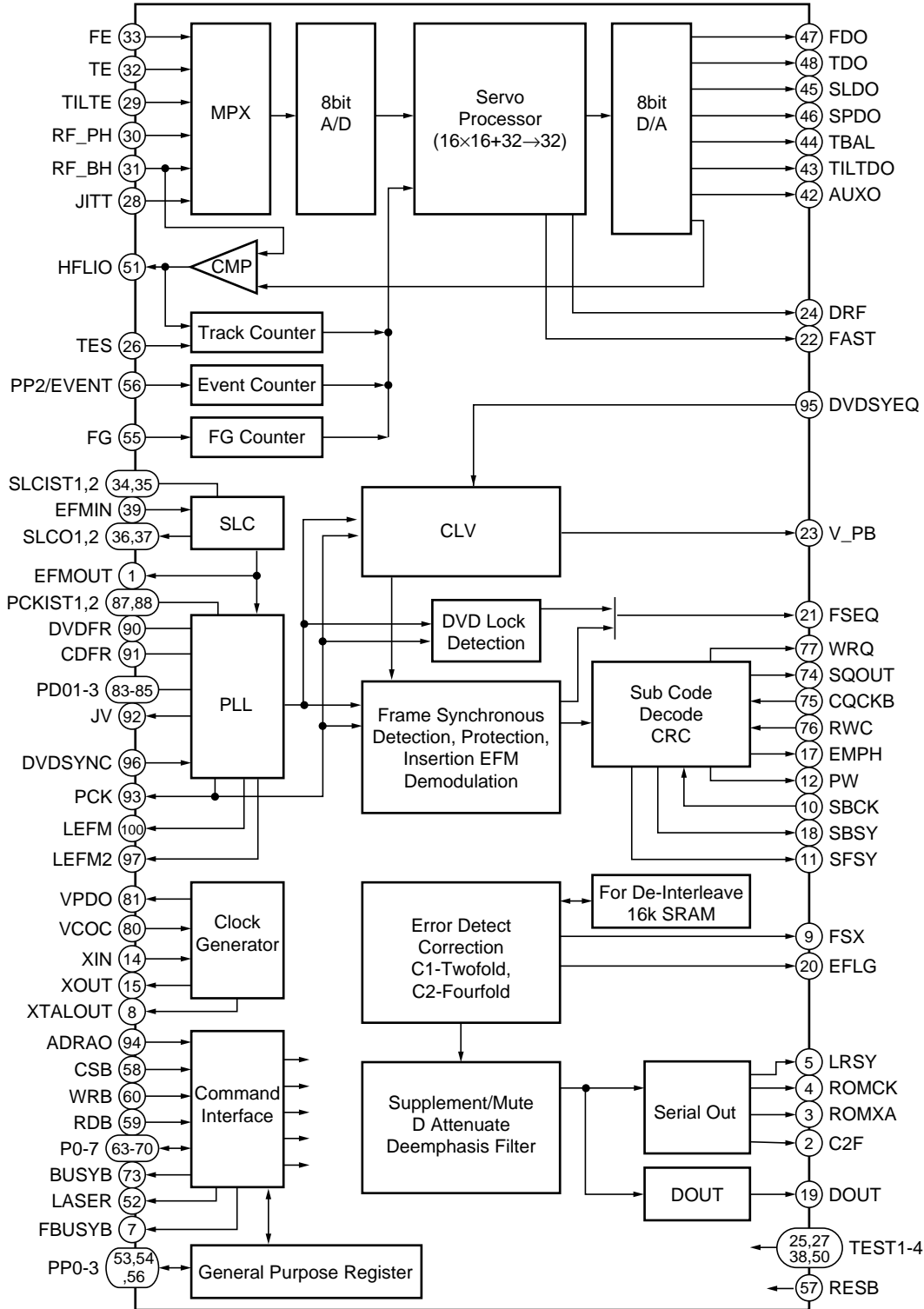

● Pin Function

No.	Pin Name	I/O	Pin Function
1	EFMOUT	O	Output the state that was binary-stated value EFM
2	C2F	O	C2 flag output
3	ROMXA	O	CD-ROM data output
4	ROMCK	O	Shift clock output for CD-ROM data output
5	LRSY	O	L/R clock output for CD-ROM data output
6	PP3	I/O	General-purpose port input/output / DVD sync. signal input N ch-OD output
7	FBUSYB	O	Busy signal output of DSP process operation N ch-OD output
8	XTALOUT	O	External system clock output
9	FSX	O	CD 1 frame sync. signal output
10	SBCK	I	Subcode reading out clock input
11	SFSY	O	Frame sync. signal output of subcode
12	PW	O	Subcode P, Q, R, S, T, U, V and W output
13	VSS	-	GND pin
14	XIN	I	Connect a crystal resonator (16.9344MHz)
15	XOUT	O	Connect a crystal resonator
16	DVDD1	-	3.3V power supply of the oscillation circuit
17	EMPH	O	Monitor pin of the deemphasis
18	SBSY	O	Sync. signal output of the subcode block
19	DOUT	O	Audio EIAJ data output
20	EFLG	O	Error correction state monitor of the error correction C1 and C2
21	FSEQ	O	Detection monitor of the CD/DVD frame sync. signal
22	FAST	O	Playback speed monitor N ch-OD output
23	V_PB	O	Monitor output of the rough servo/CLV control
24	DRF	O	In focus monitor
25	TEST3	I	Test input 3
26	TES	I	Tracking error signal input
27	TEST2	I	Test input 2
28	JITT	I	Jitter quantity detecting signal input of EFM PLL
29	TILTE	I	Tilt error signal input
30	RF_PH	I	RF peak hold signal input
31	RF_BH	I	RF bottom hold signal input
32	TE	I	Tracking error signal input
33	FE	I	Focus error signal input
34	SLCIST1	-	Current setting pin 1 of the constant current charge pump for SLC
35	SLCIST2	-	Current setting pin 2 of the constant current charge pump for SLC
36	SLCO1	O	Control output 1 for SLC
37	SLCO2	O	Control output 2 for SLC
38	TEST1	I	Test input 1
39	EFMIN	I	EFM/EFM + input
40	AVDD	-	5V power supply of A/D and D/A for servo
41	AVSS	-	GND of A/D and D/A for servo
42	AUXO	O	DA auxiliary output
43	TILTDO	O	Tilt control signal output
44	TBAL	O	Tracking balance control signal output
45	SLDO	O	Sled control signal output
46	SPDO	O	Spindle control signal output
47	FDO	O	Focus control signal output
48	TDO	O	Tracking control signal output
49	VREF	-	Reference level of D/A for servo
50	TEST4	I	Test input 4

DV-444, DV-440

No.	Pin Name	I/O	Pin Function
51	HFLIO	I/O	Mirror detection signal input/output
52	LASER	O	Output pin for laser ON/OFF control
53	PP0/DVD_CDB	I/O	General-purpose port input/output / Disc discrimination signal output
54	PP1/CRCERRB	I/O	General-purpose port input/output / Subcode CRC result signal output
55	FG	I	FG counter input
56	PP2/EVENT	I/O	General-purpose port input/output / Event counter input
57	RESB	I	Reset input
58	CSB	I	Chip select input
59	RDB	I	Internal state reading signal input
60	WRB	I	Command / data writing signal input
61	DVDD2	-	5V power supply
62	VSS	-	GND
63	P0	I/O	Command / data input/output
64	P1		
65	P2		
66	P3		
67	P4		
68	P5		
69	P6		
70	P7		
71	VSS	-	GND
72	DVDD1	-	3.3V power supply for internal
73	BUSYB	O	Busy signal output of command process
74	SQOUT	O	Serial output of subcode Q
75	CQCKB	I	Shift clock input for subcode Q data output
76	RWC	I	Update permission input of subcode Q
77	WRQ	O	Read out ready monitor of subcode Q
78	AVSS	-	PLL GND for internal system clock
79	VRPFR	-	VCO oscillation range setting of PLL for system clock
80	VCOC	I	Connect a PLL filter for system clock
81	VPDO	O	
82	AVDD	-	PLL 5V power supply for system clock
83	PDO1	I/O	PLL filter connection pin 1 for EFM playback
84	PDO2	I/O	PLL filter connection pin 2 for EFM playback
85	PDO3	I/O	PLL filter connection pin 3 for EFM playback
86	AVSS	-	PLL GND for EFM playback
87	PCKIST1	-	Current setting 1 of PLL constant current charge pump for EFM playback
88	PCKIST2	-	Current setting 2 of PLL constant current charge pump for EFM playback
89	AVDD	-	PLL 5V power supply for EFM playback
90	DVDFR	-	VCO oscillation range setting of PLL for EFM playback 1
91	CDFR	-	VCO oscillation range setting of PLL for EFM playback 2
92	JV	O	Jitter output of PLL clock for EFM playback
93	PCK	O	Bit clock output for EFM playback
94	ADRAO	I	Address input
95	DVDSYEQ	I	DVD synchronize pulse input
96	DVDSYNC	I	DVD synchronous signal input
97	LEFM2	O	Output the state that cut and out a signal which was binary-stated value EFM with PCK 2
98	DVDD1	-	3.3V power supply for I/O
99	VSS	-	GND
100	LEFM	O	Output the state that cut and out a signal which was binary-stated value EFM with PCK 1

■ BA6664FM (DVDM ASSY : IC251)

• Three-phase Motor Driver

● Block Diagram

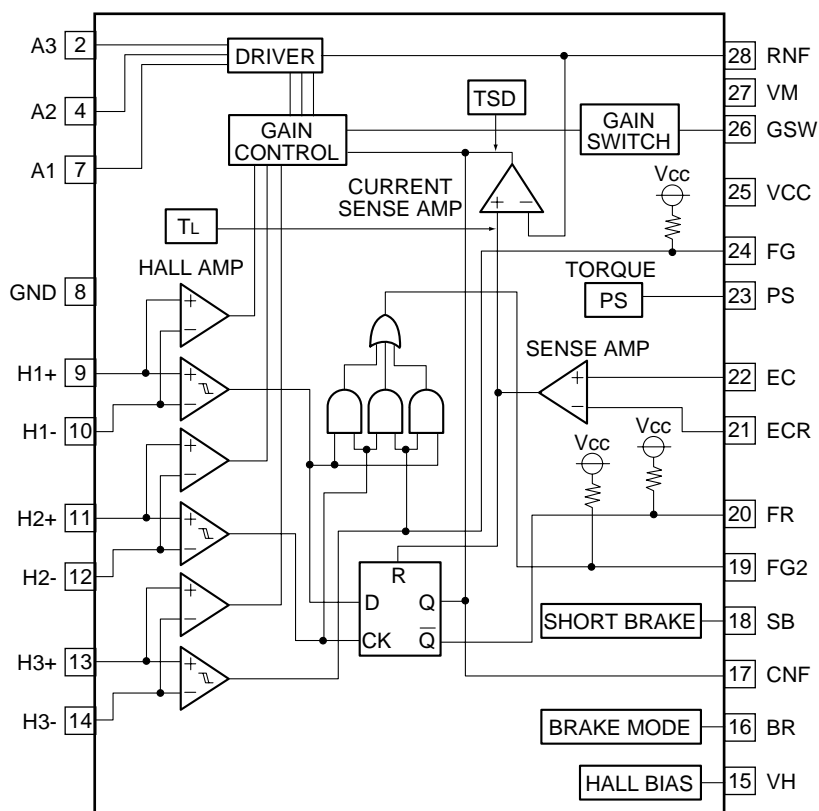

● Block Diagram

No.	Pin Name	Pin Function	No.	Pin Name	Pin Function
1	N.C.	N.C.	16	BR	Brake mode switching pin
2	A3	Output pin	17	CNF	Capacitor connection pin for phase compensation
3	N.C.	N.C.	18	SB	Short brake pin
4	A2	Output pin	19	FG2	FG 3-phase mix signal output pin
5	N.C.	N.C.	20	FR	Rotation detecting pin
6	N.C.	N.C.	21	ECR	Control reference pin of output voltage
7	A1	Output pin	22	EC	Output voltage control pin
8	GND	GND pin	23	PS	Power save pin
9	H1+	Hall signal input pins	24	FG	FG signal output pin
10	H1-		25	VCC	Power supply pin
11	H2+		26	GSW	Gain switching pin
12	H2-		27	VM	Motor power pin
13	H3+		28	RNF	Resistor connection pin for output current detection
14	H3-		FIN	FIN	GND
15	VH	Hall bias pin			

■ PD6345A (DVDM ASSY : IC601)

• FR CPU

● Pin Function

No.	Mark	Pin Name	I/O	Pin Function
1	P20/D16	D0	I/O	Data bus input/output
2	P21/D17	D1		
3	P22/D18	D2		
4	P23/D19	D3		
5	P24/D20	D4		
6	P25/D21	D5		
7	P26/D22	D6		
8	P27/D23	D7		
9	P30/D24	D8		
10	P31/D25	D9		
11	P32/D26	D10		
12	P33/D27	D11		
13	P34/D28	D12		
14	P35/D29	D13		
15	P36/D30	D14		
16	P37/D31	D15		
17	VSS	GND	-	Ground
18	P40/A00	A0	O	Address bus output
19	P41/A01	A1		
20	P42/A02	A2		
21	P43/A03	A3		
22	P44/A04	A4		
23	P45/A05	A5		
24	P46/A06	A6		
25	P47/A07	A7		
26	VCC3	V+3.3D	-	Power supply
27	VCC2	V+2.5D	-	Power supply
28	P50/A08	A8	O	Address bus output
29	P51/A09	A9		
30	P52/A10	A10		
31	P53/A11	A11		
32	P54/A12	A12		
33	P55/A13	A13		
34	P56/A14	A14		
35	P57/A15	A15		
36	VSS	GND	-	Ground
37	P60/A16	A16	O	Address bus output
38	P61/A17	A17		
39	P62/A18	A18		
40	P63/A19	A19		
41	P64/A20	A20		
42	P65/A21	TOFSTA	O	Tracking offset injection -A for servo
43	P66/A22	TOFSTC	O	Tracking offset injection -C for servo
44	P67/A23	WBL	O	For Wobble detection corresponding to DVD R/W (main)
45	DAVS	GND	-	Ground
46	DAVC	V+3.3D	-	Power supply
47	DA0	STEP1	I	For stepping motor control
48	DA1	STEP2	I	
49	DA2	LODRV	I	

No.	Mark	Pin Name	I/O	Pin Function
50	AN0	STEP2	I	For stepper control 2 For offset cancel of D/A output
51	AN1	STEP1	I	For stepper control 1 For offset cancel of D/A output
52	AN2	NAP SW	I	Rear panel H/M/L=M/A/P
53	AN3	XOEM	I	OEM model protection input
54	AN4	LD CUR	I	Input for LD current value indication
55	AN5	SELPOS	I	Tray selector input of microchanger
56	AN6	CLAMPSW	I	Clamp position SW input
57	AN7	LODPOS	I	Loading clamp position SW input
58	AVCC	V+3.3D	-	Power supply
59	AVRH	V+3.3D	-	Power supply
60	AVSS/AVRI	GND	-	Ground
61	VSS	GND	-	Ground
62	PP0/ATGX	SLDPOS	I	SW input of slider inside position
63	PP1/FRCK	GSW	O	Gain up at ACBR (at ACBR: H, others: L)
64	PP2/IN0	780ON	I	ON/OFF control signal of 780nm laser diode
65	PP3/IN1	SEDO	O	Tray rotation drive output
66	PP4/IN2	XMON	O	Mute of DRV (spindle motor ON: H)
67	PP5/IN3	XDRVMUT	O	FTS driver mute output
68	PP6	LT1	O	Communication response to the FL controller
69	PP7	XRDY	I	Communication request from the FL controller
70	VCC3	V+3.3D	-	Power supply
71	VCC2	V+2.5D	-	Power supply
72	PO0/OC0	XCURDET	I	Actuator current detection input Servo OFF for "L" 300ms
73	PO1/OC1	XCBUSY	I	Busy signal of command process Command acceptable : "L"
74	PO2/OC2	XDSPRST	O	Servo DSP reset
75	PO3/OC3	BCA	-	BCA read signal (at BCA read: H) (Not used)
76	PO4/OC4	DSCSNS/ XCD4X	I/O	Disc detection pulse "L": Disc exist Correspond to fourth speed CD playback ("L": Fourth speed)
77	PO5/OC5	PPCNT	O	Switch of TZC in WBL traversal (at PP: H)
78	PO6/OC6	XDFINH	O	Defect signal control (DEFECT ON: Hi-Z; OFF: "L")
79	PO7/OC7	DPD/TE	O	H=1 beam, L=3 beams
80	VSS	GND	-	Ground
81	PN0/AIN0	DVD/XCD	O	RF EQ switching signal at DVD/CD "H": DVD, "L": CD
82	PN1/BIN0	AGOFF	O	"H": Turn off AGC of RFIC
83	PN2/AIN1	650X780	O	780nm/650nm switching signal
84	PN3/BIN1	LD ON	O	ON/OFF control signal of laser diode
85	PN4/AIN2	FOFST2	O	Focus offset adjustment 1 (Tri-value control "H", "L", Hi-Z)
86	PN5/BIN2	FOFST1	O	Focus offset adjustment 2 (Tri-value control "H", "L", Hi-Z)
87	PN6/AIN3	XCD2X	O	For VCD double speed playback
88	PN7/BIN3	OEICG	O	"H": Gain of OEIC up to 6dB
89	PM0/ZIN0	TRYPOS	I	Count input of disc number
90	PM1/ZIN1	N/XP SW	O	Video encoder control port (NTSC/PAL)
91	PM2/ZIN2	V SEL	O	(Composite, S) / (YCbCr) or (RGB) switch
92	PM3/ZIN3	V SEL2	O	(Composite) of skirt terminal / (S) switch
93	PL0/SDA1	SDAI		12C control lines
94	PL1/SDA0	SDAO		
95	PL2/SCL1	SCLI		
96	PL3/SCL0	SCLO		
97	PL4	CTS	I	RS-232C clear to send input
98	PL5	DTR	O	RS-232C clear to send output
99	PL6/UC0	-	-	-
100	VSS	GND	-	Ground

DV-444, DV-440

No.	Mark	Pin Name	I/O	Pin Function
101	PK0/TIN0	XVQERST	O	VQE3 reset signal
102	PK1/TIN1	XCSPRO1	-	Serial communication enable of the progressive converter IC
103	PK2/TIN2	XCSVQE5	-	Serial communication enable of VQE5 IC
104	PK3/TIN3	N.C.	-	N.C.
105	PK4/TOT0	44X48	O	DAC and DASP supply clock fs 44/48 selection
106	PK5/TOT1	DI ERR	I	DIR reception error (unlock signal) input
107	PK6/TOT2	XMICON2 AOSEL1	O	Mic center MIX signal for multi CH AV-1/audio DSP switch (front L/R data)
108	PK7/TOT3	AOSEL0	-	AV1 output AOD and AO0 switch
109	VCC3	V+3.3D	-	Power supply
110	VCC2	V+2.5D	-	Power supply
111	PJ0/INT0	XINT0	I	
112	PJ1/INT1	XINT1	I	
113	PJ2/INT2	XIRQ10	I	MY chip interrupt #0
114	PJ3/INT3	XIRQ11	I	MY chip interrupt #1
115	PJ4/INT4	XABUSY	I	Busy signal of DSP process operation "L"
116	PJ5/INT5	THLD	I	Playback speed monitoring signal
117	PJ6/INT6	SBSY	I	Sync. signal of subcode block (period SO+SI "H")
118	PJ7/INT7	N.C.	I	N.C.
119	PI0/SI0	SSI	I	Serial bus data input
120	PI1/SO0	SSO	O	Serial bus data output
121	PI2/SCK0	SSCK	I	Serial bus clock input
122	PI3/SI1	RXD	I	RS-232C RXD
123	PI4/SO1	TXD	O	RS-232C TXD
124	PI5/SCK1	SELMOD	-	Audio DSP mode switch
125	PH0/SI2	RESET2	-	Reset for DSP 2
126	PH1/SO2	XCSADSP1	O	CS for DSP 2
127	PH2/SCK2	XCSSPD	-	Latch signal of serial/parallel IC for generating audio DSP control signal
128	MD0	GND	-	Ground
129	MD1	GND	-	
130	MD2	GND	-	
131	VSS	GND	-	Ground
132	VCC2	V+2.5D	-	Power supply
133	VSS	GND	-	Ground
134	X1	EXTAL	O	
135	X0	XTAL	I	
136	VCC3	V+3.3D	-	Power supply
137	PC0/DREQ2	LFEON RESET1	O	Select Mix to front L/R of LFE element DSP 1 reset
138	PC1/DACK2	XMICON1 AV1/XSDSP	O	Mic front L/R MIX signal for 2 ch AV-1/servo DSP switch
139	PC2/DEOP2	6CHMD	O	DAC output 2 ch/6 ch switch (←XDVRST2)
140	PB0/DREQ0	XDREQ0	I	DMA response output to BY Chip
141	PB1/DACK0	DACK0	O	DMA request input from BY Chip
142	PB2/DEOP0	N.C.	-	N.C.
143	PB3/DREQ1	XDREQ1	I	DMA response output to AV-1 Chip
144	PB4/DACK1	XDACK1	O	DMA request input from AV-1 Chip
145	PB5/DEOP1	XEXCKON	O	ON/OFF switch of DSP external clock
146	PB6/IOWRX	DOISEL1	O	Digital output switch 1 of audio DSP (AV-1. DSP and GND)
147	PB7/IORDX	DOISEL2	O	Digital output switch 2 of audio DSP (AV-1. DSP and GND)
148	VSS	GND	-	Ground
149	PA0/CSOX	XCS20	O	Chip select output to Flash ROM
150	PA1/CS1X	XCS6	O	AV-1 Chip select

No.	Mark	Pin Name	I/O	Pin Function
151	PA2/CS2X	XCS3	O	Chip select of PD4995A (MY Chip)
152	PA3/CS3X	XCS4	O	Chip select of servo DSP
153	PA4/CS4X	XCS23	O	Chip select output to SRAM (1M)
154	PA5/CS5X	N.C.	O	N.C.
155	PA6/CS6X	N.C.	O	N.C.
156	PA7/CS7X	N.C.	O	N.C.
157	VCC3	V+3.3D	-	Power supply
158	VCC2	V+2.5D	-	Power supply
159	NMIX	-	-	V+3.3D fixed
160	HSTX	-	-	V+2.5D fixed
161	INITX	XINIT	I	
162	P80/RDY	RDY	I	
163	P81/BGRNTX	XAMUTE	I	Final stage mute of 2 ch audio output
164	P82/BRQ	XMMUTE	O	Audio multi channel mute
165	P83/RDX	XRD	O	
166	P84/WR0X	XWR0	O	
167	P85/WR1X	XWR1	O	
168	VSS	GND	-	Ground
169	P90/SYSCLK	SYSCLK	O	
170	P91	DFRST	-	DAC reset (for front L/R)
171	P92/MCLK	DFRST1	-	DAC reset (for center, surround and LFE)
172	P93	XCSDf0	O	DAC chip select (\leftarrow XLAT3)
173	P94/LBAX	XCSDf1	O	DAC chip select for center, surround and LFE
174	P95/BAAX	XAQRST	O	AQE reset
175	P96	XCSAQE	O	AQE chip select
176	P97/WEX	TM ENT	I	Test mode entry

■ M65774BFP (DVDM ASSY : IC801)

- MPEG2 Decoder IC
- Block Diagram

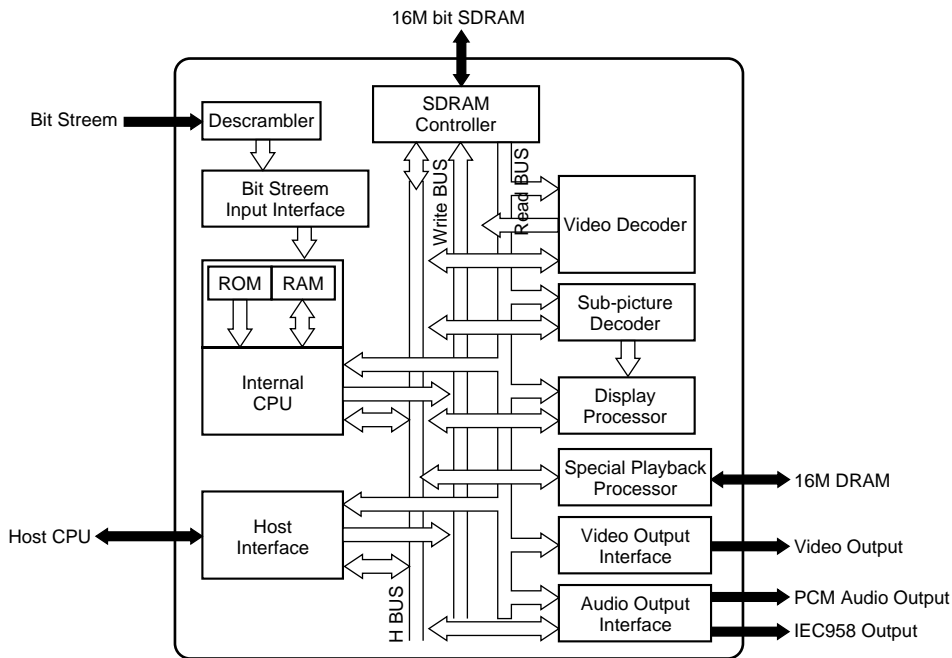

• Pin Function

No.	Pin Name	I/O	Pin Function	No.	Pin Name	I/O	Pin Function
1	GND	I	Ground	21	5VDD	I	5V power supply
2	HD0	I/O	Data input and output port	22	HD15	I/O	Data input and output port
3	HD1			23	CS	I	Chip select signal input
4	HD2			24	RE	I	Read Enable signal input
5	HD3			25	WE	I	Write Enable signal input
6	HD4			26	BHE	I	Byte High Enable signal input
7	5VDD	I	5V power supply	27	RDY	O	Acknowledge signal which is indicated the finish of data reading or writing via the host bus
8	VDD	I	Power supply	28	INTR	O	Interrupt request signal against to the external CPU from M65773FP
9	HD5	I/O	Data input and output port	29	GND	I	Ground
10	HD6			30	HA0	I	Address input port
11	HD7			31	HA1		
12	HD8			32	HA2		
13	HD9			33	HA3		
14	GND	I	Ground	34	HA4		
15	HD10	I/O	Data input and output port	35	VDD	I	Power supply
16	HD11			36	5VDD	I	5V power supply
17	HD12			37	HA5	I	Address input port
18	HD13			38	HA6		
19	HD14			39	HA7		
20	VDD	I	Power supply	40	HA8		

No.	Pin Name	I/O	Pin Function	No.	Pin Name	I/O	Pin Function	
41	HA9	I	Address input port	83	VDD	I	Power supply	
42	GND	I	Ground	84	VSYNC	O	Vertical sync. signal output	
43	CDMCK	I	Connect to ground	85	HSYNC	O	Horizontal sync. signal output	
44	CDLRCK	I	L/R clock input from CDDSP	86	PICSTRT			
45	CDBCK	I	PCM bit clock input from CDDSP	87	MBSTRT			
46	CDDATA	I	Digital audio interface input	88	MBDATA			
47	VDD	I	Power supply	89	GND	I	Ground	
48	CDDIN	I	PCM audio data input from CDDSP	90	PWD	O	Phase comparator output for external sync. operation	
49	INT2	O	Interrupt request signal against to the external CPU from M65773FP	91	CSYNC	I	Composite SYNC signal input	
50	INT3			92	OSDKEY	O	OSD key flag output	
51	DREQ	O	DMA request signal for OSD bitmap transfer	93	PXCLK	O	Pixel clock (27MHz free-running clock)	
52	DACK	I	DMA acknowledge signal for OSD bitmap transfer	94	VDD	I	Power supply	
53	GND	I	Ground	95	PD7	O	Digital pixel data	
54	CKO	O	27MHz clock output	96	PD6			
55	CLKIN	I	System clock input	97	PD5			
56	AVDD1	I	Analog power supply	98	PD4			
57	AGND1	I	Analog ground	99	GND	I	Ground	
58	AGND3			100	PD3	O	Digital pixel data	
59	AVDD3	I	Analog power supply	101	PD2			
60	CCAP	I	Connect to ground	102	PD1			
61	AGND2	I	Analog ground	103	PD0			
62	AVDD2	I	Analog power supply	104	VDD	I	Power supply	
63	ACLKO	-	Open	105	GND	I	Ground	
64	ACLKI	I	Audio clock input	106	RESET	I	Hardware reset input	
65	HMODE1	I	Setting pin of host interface operating mode	107	TEST0	I	Connect to ground normally	
66	GND	I	Ground	108	TEST1			
67	VDD	I	Power supply	109	TEST2			
68	AOD	O	PCM output of audio data	110	VDD	I	Power supply	
69	AO2			I/O	Data transfer line with DRAM	111	NMD0	
70	AO1					112	NMD15	
71	AO0					113	NMD1	
72	GND	I	Ground	114	NMD14			
73	DOUT1	O	Digital audio interface output	115	GND	I	Ground	
74	DOUT0			116	NMD2	I/O	Data transfer line with DRAM	
75	SDA	-	Open	117	NMD13			
76	SCL	-	Open	118	NMD3			
77	VDD	I	Power supply	119	NMD12			
78	GND	I	Ground	120	VDD	I	Power supply	
79	DACCLK	O	Over-sampling operating clock output	121	NMD4	I/O	Data transfer line with DRAM	
80	DOCLK	O	PCM bit clock output	122	NMD11			
81	LRCLK	O	Clock output for discriminating the channel (L/R) of PCM audio data	123	NMD5			
82	HMODE0	I	Setting pin of host interface operating mode	124	NMD10			

DV-444, DV-440

No.	Pin Name	I/O	Pin Function	No.	Pin Name	I/O	Pin Function
125	GND	I	Ground	167	MA5	O	Address line with SDRAM
126	NMD6	I/O	Data transfer line with DRAM	168	GND	I	Ground
127	NMD9			O	Address line with SDRAM		
128	NMD7						
129	NMD8						
130	VDD	I	Power supply	172	MA7		
131	NCAS0	O	CAS (Column Address Strobe) control line of DRAM	173	VDD	I	Power supply
132	NWE	O	WE control line of DRAM	174	MA10	O	Address line with SDRAM
133	NCAS1	O	CAS (Column Address Strobe) control line of DRAM	175	MA8		
134	NRAS	O	RAS (Row Address Strobe) control line of DRAM	176	MA11		
135	GND	I	Ground	177	MA9		
136	NMA9	O	Address line with DRAM	178	GND	I	Ground
137	NMA8			179	DCS	O	Chip select of SDRAM
138	VDD	I	Power supply	180	RAS	O	RAS (Row Address Strobe) control line of SDRAM
139	NMA0	O	Address line with DRAM	181	CAS	O	CAS (Column Address Strobe) control line of SDRAM
140	NMA7			182	VDD	I	Power supply
141	NMA1			183	MCLK	O	Operation clock of SDRAM
142	NMA6			184	GND	I	Ground
143	GND	I	Ground	185	DWE	O	WE control line of SDRAM
144	NMA2	O	Address line with DRAM	186	DQMU	O	DQM control line of SDRAM Use for mask of upper byte output.
145	NMA5			187	DQML	O	DQM control line of SDRAM Use for mask of lower byte output.
146	NMA3			188	VDD	I	Power supply
147	NMA4			189	MD7	I/O	Data transfer line with SDRAM
148	VDD	I	Power supply				
149	BD7	I	Bit stream input port	190	MD8		
150	BD6	I	Bit stream input port	191	MD6		
151	GND			I	Ground	192	MD9
152	BD5	I	Bit stream input port	193	GND	I	Ground
153	BD4			I/O	Data transfer line with SDRAM		
154	BD3						
155	BD2						
156	VDD	I	Power supply	198	VDD	I	Power supply
157	GND	I	Ground	199	MD3	I/O	Data transfer line with SDRAM
158	BD1	I	Bit stream input port	200	MD12		
159	BD0			201	MD2		
160	BCLK	I	Strobe signal (clock) of BD port	202	MD13		
161	BDEN	I	Indicates the effective or invalid data which is sampled from BD port	203	GND	I	Ground
162	BDREQ	O	Output permission signal against to the device (channel decoder) which connecting to BD port	204	MD1	I/O	Data transfer line with SDRAM
163	VDD	I	Power supply	205	MD14		
164	MA3	O	Address line with SDRAM	206	MD0		
165	MA4			207	MD15		
166	MA2			208	VDD	I	Power supply

■ ADV7172KST (DVDM ASSY : IC861)

- Digital PAL/NTSC Video Encoder with Six DACs (10-bits), Color Control and Enhanced Power Management
- Pin Arrangement

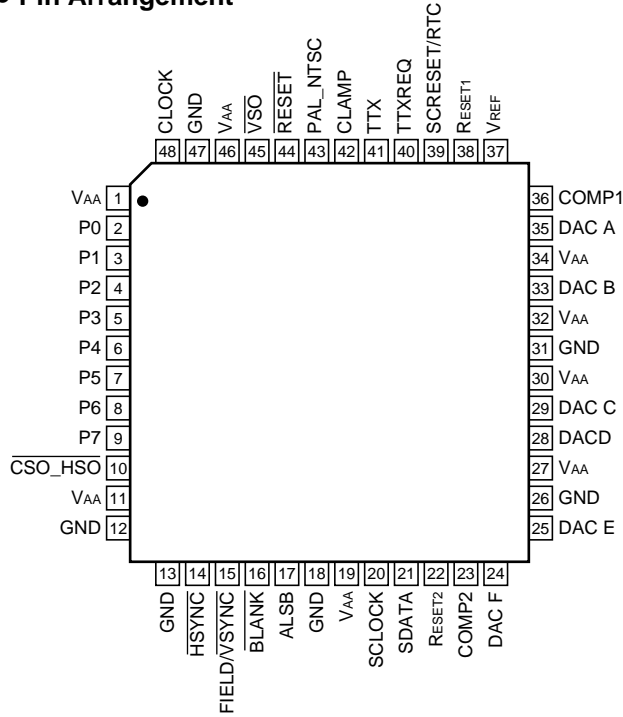

• Block Diagram

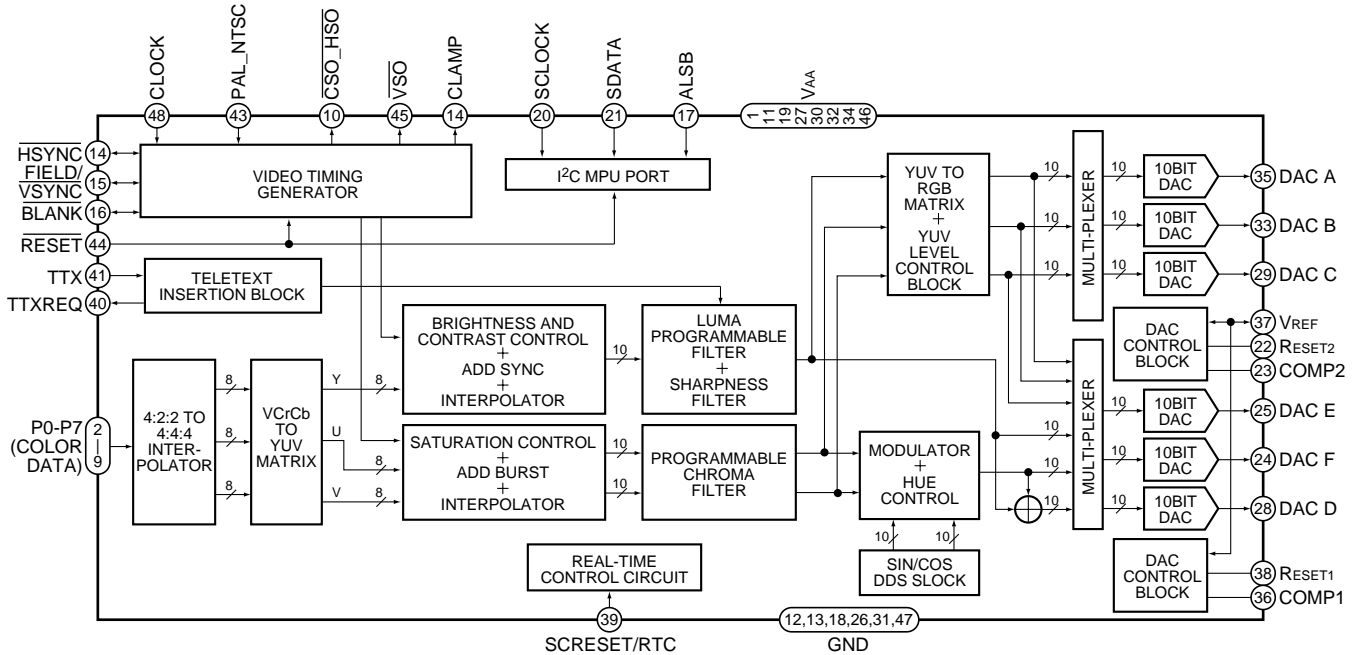

• Pin Function

No.	Name	I/O	Pin Function
1	VAA	P	Power Supply (+3V to +5V)
2	P0	I	8-bit 4 : 2 : 2 Multiplexed YCrCb Pixel Port (P7-P0) P0 represents the LSB
3	P1		
4	P2		
5	P3		

No.	Name	I/O	Pin Function
6	P4	I	8-bit 4 : 2 : 2 Multiplexed YCrCb Pixel Port (P7-P0) P0 represents the LSB
7	P5		
8	P6		
9	P7		
10	CSO_HSO	O	Dual function CSO or HSO TTL Output Sync Signal
11	V _{AA}	P	Power Supply (+3V to +5V)
12	GND	G	Ground Pin
13	GND	G	Ground Pin
14	HSYNC	I/O	HSYNC (Models 1 and 2) Control Signal. This pin may be configured to output (Master Mode) or as an input and accept (Slave Mode) Sync signals.
15	FIELD/VSYNC	I/O	Dual Function FIELD (Mode1) and VSYNC (Mode2) Control Signal. This pin may be configured to output (Master Mode) or as an input (Slave Mode) and accept these control signals.
16	BLANK	I/O	Video Blanking Control Signal. The pixel inputs are ignored when this is logic level "0". This signal is optional.
17	ALSB	I	TTL Address Input. This signal sets up the LSB of the MPU address.
18	GND	G	Ground Pin
19	V _{AA}	P	Power Supply (+3V to +5V)
20	SCLOCK	I	MPU Port Serial Interface Clock Input
21	SDATA	I/O	MPU Port Serial Data Input/Output
22	RSET2	I	A 600 ohm resistor connected from this pin to GND is used to control full-scale amplitudes of the Video Signals from DACs D, E and F (the "small" DACs).
23	COMP2	O	Compensation Pin for DACs d, E and F. Connect a 0.1µF Capacitor from COMP to V _{AA} .
24	DAC F	O	RED/S-Video C/V Analog Output. This DAC is capable of providing 8.66 mA output.
25	DAC E	O	BLUE/S-Video Y/U Analog Output. This DAC is capable of providing 8.66 mA output.
26	GND	G	Ground Pin
27	V _{AA}	P	Power Supply (+3V to +5V)
28	DAC D	O	GREEN/Composite/Y Analog Output. This DAC is capable of providing 8.66 mA output.
29	DAC C	O	RED/S-Video C/V Analog Output. This DAC is capable of providing 34.66 mA output.
30	V _{AA}	P	Power Supply (+3V to +5V)
31	GND	G	Ground Pin
32	V _{AA}	P	Power Supply (+3V to +5V)
33	DAC B	O	BLUE/S-Video Y/U Analog Output. This DAC is capable of providing 34.66 mA output.
34	V _{AA}	P	Power Supply (+3V to +5V)
35	DAC A	O	GREEN/Composite/Y Analog Output. This DAC is capable of providing 34.66 mA output.
36	COMP1	O	Compensation Pin for DACs A, B and C. Connect a 0.1µF Capacitor from COMP to V _{AA} . For Optimum Dynamic Performance in Low Power Mode, the value of the COMP1 capacitor can be lowered to as low as 2.2mF.
37	V _{REF}	I/O	Voltage Reference Input for DACs or Voltage Reference Output (1.235V)
38	RSET1	I	A 150 ohm resistor connected from this pin to GND is used to control full-scale amplitudes of the Video Signals from DACs A, B and C (the "large" DACs).
39	SCRESET/RTC	I	This pin can be configured as an input by setting MR42 and MR41 of Mode Resistor 4. It can be configured as a subcarrier reset pin, in which case a high to low transition on this pin will reset the subcarrier phase to Field 0. Alternatively it may be configured as a Real-Time Control (RTCF) Input.
40	TTXREQ	O	Teletext Data Request input signal used to control teletext data transfer.
41	TTX	O	Teletext Data Input Pin.
42	CLAMP	O	TTL Output Signal to external circuitry to enable clamping of all video signals.
43	PAL_NTSC	I	Input signal to select PAL or NTSC mode of operation, pin set to Logic "1" selects PAL.
44	RESET	I	The input resets the on-chip timing generator and sets the ADV7172KST into default mode. This is NTSC operation, Timing Slave Mode 0, DACs A, B and C powered OFF, DACs D, E and F powered ON, Composite and S-Video out.
45	VSO	O	VSO TTL Output Sync Signal
46	V _{AA}	P	Power Supply (+3V to +5V)
47	GND	G	Ground Pin
48	CLOCK	I	TTL Clock Input. Requires a stable 27 MHz reference clock for standard operation. Alternatively, a 24.52 MHz (NTSC) or 29.5 MHz (PAL) can be used for square pixel operation.

■ PM0026A (DVDM ASSY : IC881) (DV-444 Only)

- Progressive Scan Converter (PRO-1)

• Pin Arrangement

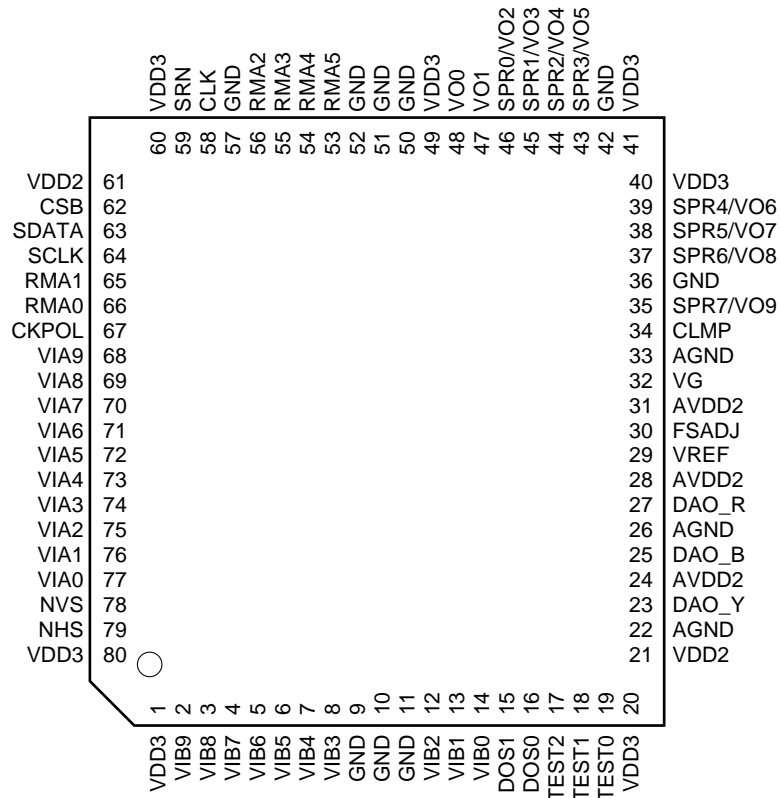

• PBlock Diagram

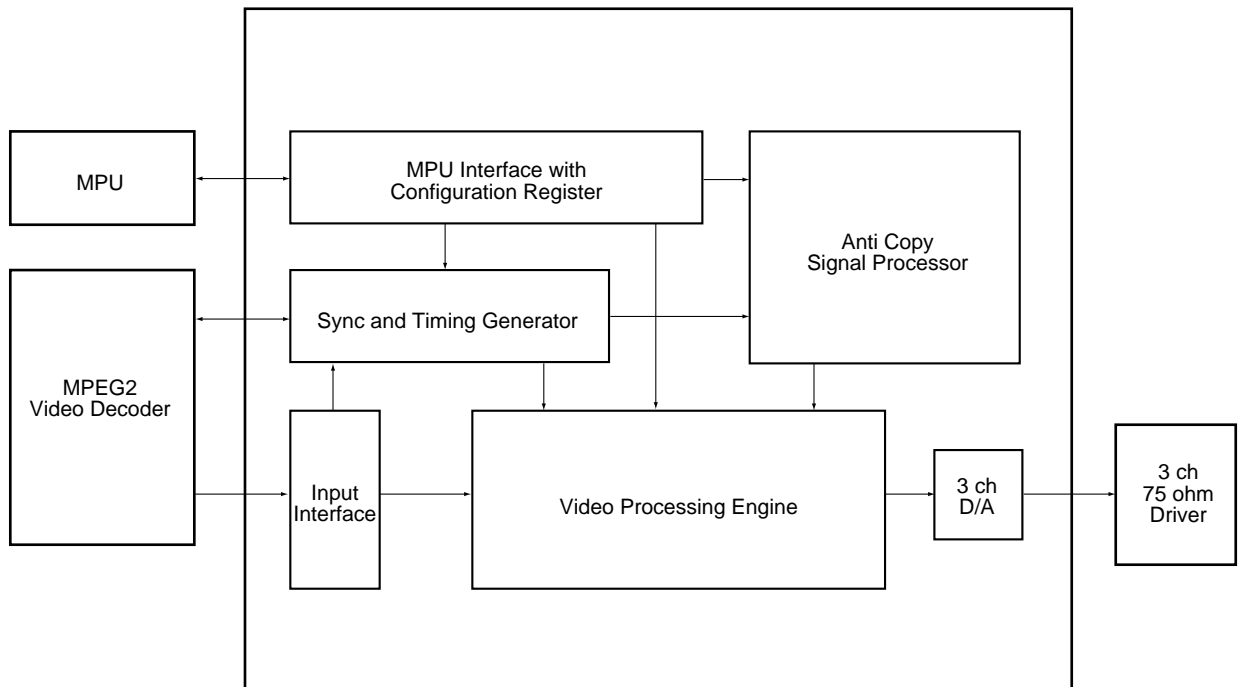

● Pin Function

No.	Pin Name	I/O	Pin Function
1	VDD3	–	VDD (3.3V) for IO
2	VIB9	I	Video data B input (MSB)
3	VIB8		
4	VIB7		
5	VIB6		
6	VIB5		
7	VIB4		
8	VIB3		
9	GND		
10	GND		
11	GND		
12	VIB2	I	Video data B input (LSB)
13	VIB1		
14	VIB0		
15	DOS1	I	Test input pins (ground)
16	DOS0		
17	TEST2		
18	TEST1		
19	TEST0		
20	VDD3	–	VDD (3.3V) for IO
21	VDD2	–	VDD (2.5V) for Core
22	AGND	–	Ground for DAC
23	DAO_Y	O	Analog video output (Y)
24	AVDD2	–	VDD (2.5V) for DAC
25	DAO_B	O	Analog video output (Cb)
26	AGND	–	Ground for DAC
27	DAO_R	O	Analog video output (Cr)
28	AVDD2	–	VDD (2.5V) for DAC
29	VREF	I	DAC reference voltage input
30	FSADJ	I/O	Resistor connection pin for maximum amplitude setting of DAC
31	AVDD2	–	VDD (2.5V) for DAC
32	VG	O	Reactance connection pin for gate voltage compensation of DAC current cell
33	AGND	–	Ground for DAC
34	CLMP	O	Clamp pulse output
35	SPR7/VO9	O	Serial and parallel conversion (MSB) / Video data output (MSB)
36	GND	–	Digital ground
37	SPR6/VO8	O	Serial and parallel conversion / Video data output
38	SPR5/VO7		
39	SPR4/VO6		
40	VDD3	–	VDD (3.3V) for IO

No.	Pin Name	I/O	Pin Function
41	VDD3	–	VDD (3.3V) for IO
42	GND	–	Digital ground
43	SPR3/VO5	O	Serial and parallel conversion / video data output (LSB)
44	SPR2/VO4		
45	SPR1/VO3		
46	SPR0/VO2		
47	VO1		
48	VO0		
49	VDD3		
50	GND	–	Digital ground
51	GND		
52	GND		
53	RMA5	I	Resgister monitor address input (MSB)
54	RMA4		
55	RMA3		
56	RMA2		
57	GND	–	Digital ground
58	CLK	I	27 MHz system clock input
59	SRN	I	System reset input
60	VDD3	–	VDD (3.3V) for IO
61	VDD2	–	VDD (2.5V) for Core
62	CSB	I	Chip select input of MPU serial interface
63	SDATA	I	Data input of MPU serial interface
64	SCLK	I	Clock input of MPU serial interface
65	RMA1	I	Register monitor address input (LSB)
66	RMA0		
67	CKPOL	–	Polarity setting input of internal system clock
68	VIA9	I	Video data A input (MSB)
69	VIA8		
70	VIA7		
71	VIA6		
72	VIA5		
73	VIA4		
74	VIA3		
75	VIA2		
76	VIA1		
77	VIA0		
78	NVS	I/O	Vertical sync. input/output
79	NHS		Horizontal sync. input/output
80	VDD3	–	VDD (3.3V) for IO

■ PCM1742KE (JACB ASSY : IC211)

• D/A Converter

• Pin Arrangement



• Pin Function

No.	Nmae	I/O	Pin Function
1	BCK	I	Audio data bit clock input
2	DATA	I	Audio data digital input
3	LRCK	I	L-channel and R-channel Audio data latch enable input
4	DGND	-	Digital ground
5	VDD	-	Digital power supply +3.3V
6	VCC	-	Analog power supply +5V
7	VOUTL	O	Analog output for L-channel
8	VOUTR	O	Analog output for R-channel
9	AGND	-	Analog ground
10	VCOM	-	Common voltage decoupling
11	ZEROR/ZEROA	O	Zero flag output for R-channel / Zero flag output for L/R-channel
12	ZEROL/NA	O	Zero flag output for L-channel / No assign
13	MD	I	Mode control data input
14	MC	I	Mode control clock input
15	ML	I	Mode control latch input
16	SCK	I	System clock input

• Block Diagram

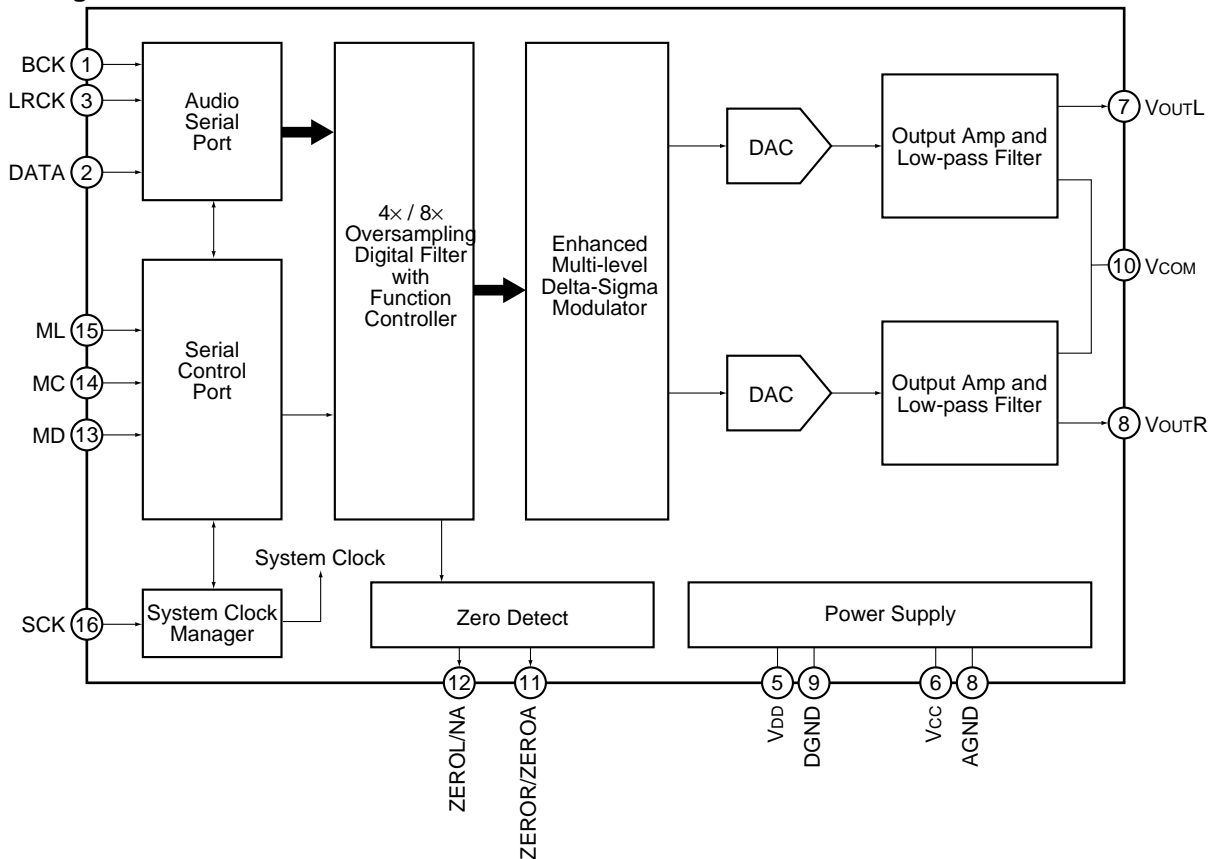

■ MM1540BF (JACB ASSY : IC411)(DV-440 Only)

• 75Ω × 2 Driver for DVD (6 ch / 9dB)

● Pin Arrangement

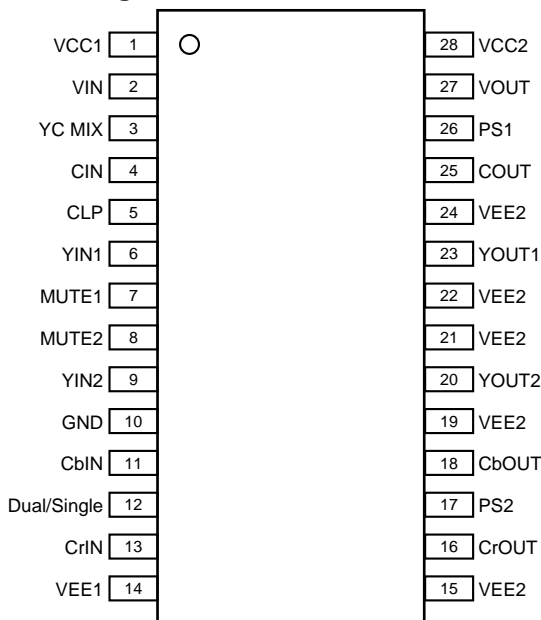

● Block Diagram

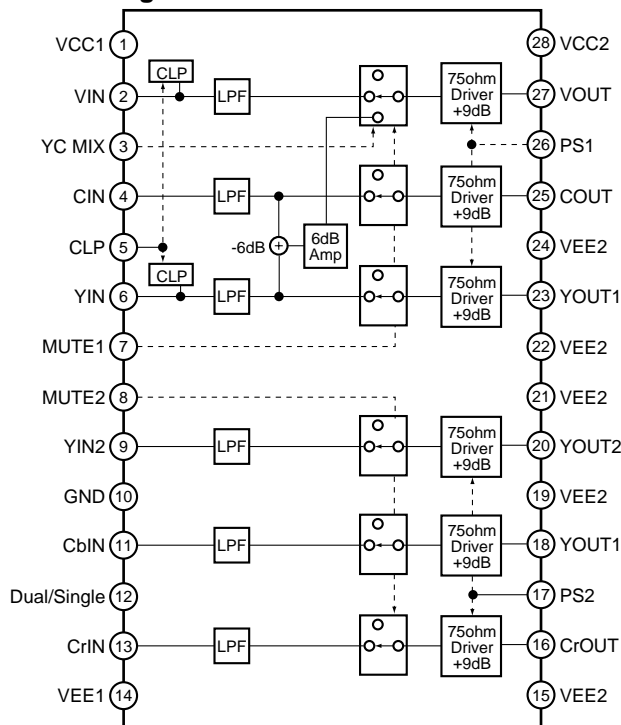

● Pin Function

No.	Name	Pin Function	No.	Name	Pin Function
1	VCC1	VCC	15	VEE2	VEE
2	VIN	Video input	16	CrOUT	Video input
3	YC MIX	YC MIX select	17	PS2	Power save select
4	CIN	Croma input	18	CbOUT	Vide output
5	CLP	Clamp select	19	VEE2	VEE
6	YIN1	Video input	20	YOUT2	Vide output
7	MUTE1	Mute select	21	VEE2	VEE
8	MUTE2	Mute select	22	VEE2	VEE
9	YIN2	Component input	23	YOUT1	Vide output
10	GND	Ground	24	VEE2	VEE
11	CbIN	Component input	25	COOUT	Vide output
12	Dual/Single	Power supply select	26	PS1	Power save select
13	CrIN	Component input	27	VOUT	Vide output
14	VEE1	VEE	28	VCC2	VCC

MM1540CF (JACB ASSY : IC411)(DV-444 Only)

• 75Ω × 2 Driver for DVD (6 ch / 9dB / for progressive)

Pin Arrangement

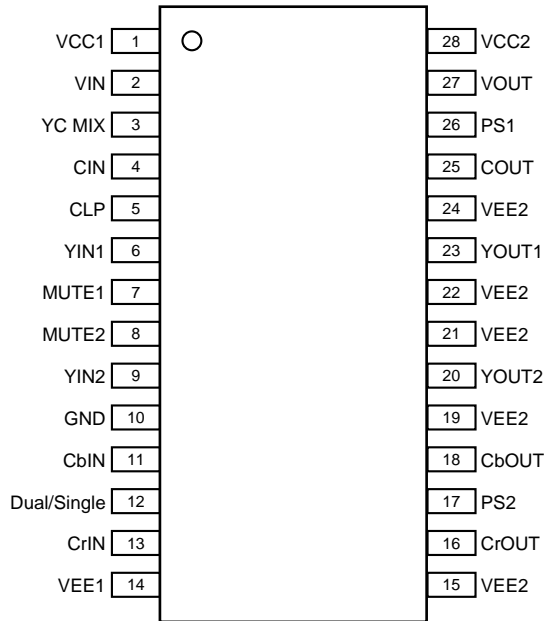

Block Diagram

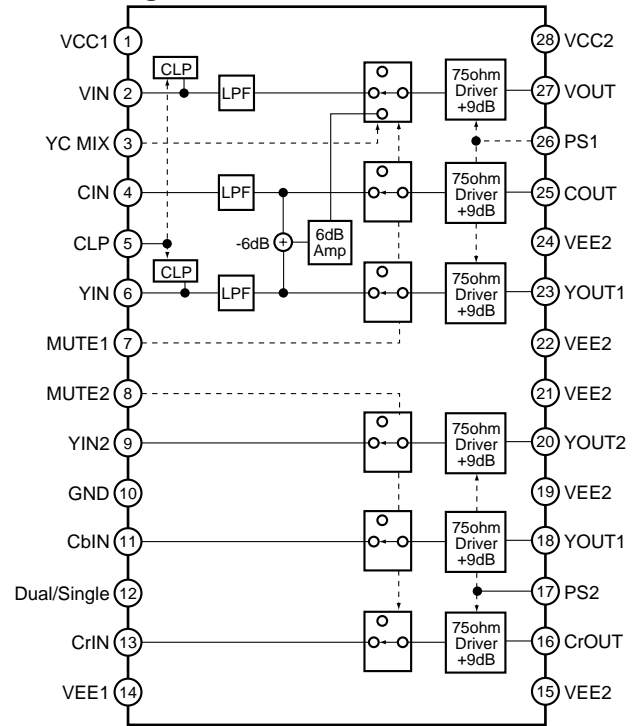

Pin Function

No.	Name	Pin Function	No.	Name	Pin Function
1	VCC1	VCC	15	VEE2	VEE
2	VIN	Video input	16	CrOUT	Video output
3	YC MIX	YC MIX select	17	PS2	Power save select
4	CIN	Croma input	18	CbOUT	Vide output
5	CLP	Clamp select	19	VEE2	VEE
6	YIN1	Video input	20	YOUT2	Vide output
7	MUTE1	Mute select	21	VEE2	VEE
8	MUTE2	Mute select	22	VEE2	VEE
9	YIN2	Component input	23	YOUT1	Vide output
10	GND	Ground	24	VEE2	VEE
11	CbIN	Component input	25	COUT	Vide output
12	Dual/Single	Power supply select	26	PS1	Power save select
13	CrIN	Component input	27	VOUT	Vide output
14	VEE1	VEE	28	VCC2	VCC

■ PE5251A (FLKB ASSY : IC101)

• Mode Control IC

• Pin Function

No.	Pin Name	I/O	Pin Function
1	VDD1	–	Positive power supply (excepting port, analog and FIP controller/driver section)
2	VSS1	–	Ground (excepting port and analog)
3	X1	I	Connect a crystal for main system clock oscillation
4	X2	–	
5	IC	–	Internal connection Connect to Vss1 directly.
6	$\overline{\text{RESET}}$	I	System reset input
7	P27/ $\overline{\text{SCK1}}$	I/O	Port 2 8 bit input/output port / serial clock input/output
8	P26/SI1	I/O I	Port 2 8 bit input/output port / Serial data input
9	P25/SO1	I/O O	Port 2 8 bit input/output port / Serial data output
10	P24/BUSY	I/O I	Port 2 8 bit input/output port / Busy signal input
11	P23	I/O	Port 2 8 bit input/output port
12	P22		
13	P21/SO3	I/O O	Port 2 8 bit input/output port / Serial data output
14	P20/ $\overline{\text{SCK3}}$	I/O	Port 2 8 bit input/output port / serial clock input/output
15	P00/INTP0	I/O I	Port 0 3 bit input/output port / External interrupt request input
16	P01/INTP1		
17	P02/TI	I/O I	Port 0 3 bit input/output port / Timer input of 8 bit remote control timer (TM9)
18	AVSS	–	Ground of A/D converter
19	ANI3	I	Analog input of A/D converter
20	ANI2		
21	ANI1		
22	ANI0		
23	VSS0	–	Ground of port section
24	AVDD	–	Analog power supply of A/D converter / reference voltage input
25	VDD0	–	Positive power supply of port section
26	P64	I/O	Port 6 5-bit high proof pressure input/output ports of P-ch open drain
27	P63		
28	P62		
29	P61		
30	P60		
31	P57	I/O	Port 5 8-bit high proof pressure input/output ports of P-ch open drain
32	P56		
33	P55		
34	P54		
35	P53		
36	P52		
37	P51		
38	P50		
39	P47	O	Port 4 8-bit high proof pressure input/output ports of P-ch open drain
40	P46		

DV-444, DV-440

No.	Pin Name	I/O	Pin Function
41	P45	○	Port 4 8-bit high proof pressure input/output ports of P-ch open drain
42	P44		
43	P43/FIP35	○	Port 4 8-bit high proof pressure input/output ports of P-ch open drain / High proof pressure large current output of FIP controller/driver
44	P42/FIP34		
45	P41/FIP33		
46	P40/FIP32		
47	P37/FIP31	○	Port 3 8-bit high proof pressure input/output ports of P-ch open drain / High proof pressure large current output of FIP controller/driver
48	P36/FIP30		
49	P35/FIP29		
50	P34/FIP28		
51	P33/FIP27		
52	P32/FIP26		
53	P31/FIP25		
54	P30/FIP24		
55	FIP23	○	High proof pressure large current output of FIP controller/driver
56	FIP22		
57	FIP21		
58	FIP20		
59	VDD2	–	Positive power supply of FIP controller/driver section
60	VLOAD	–	Connect a pull-down resistor of FIP controller/driver
61	FIP19	○	High proof pressure large current output of FIP controller/driver
62	FIP18		
63	FIP17		
64	FIP16		
65	FIP15		
66	FIP14		
67	FIP13		
68	FIP12		
69	FIP11		
70	FIP10		
71	FIP9		
72	FIP8		
73	FIP7		
74	FIP6		
75	FIP5		
76	FIP4		
77	FIP3		
78	FIP2		
79	FIP1		
80	FIP0		

7.2.2 FL DISPLAY

■ VAW1063 (FLKB ASSY : V101)

• FL Tube

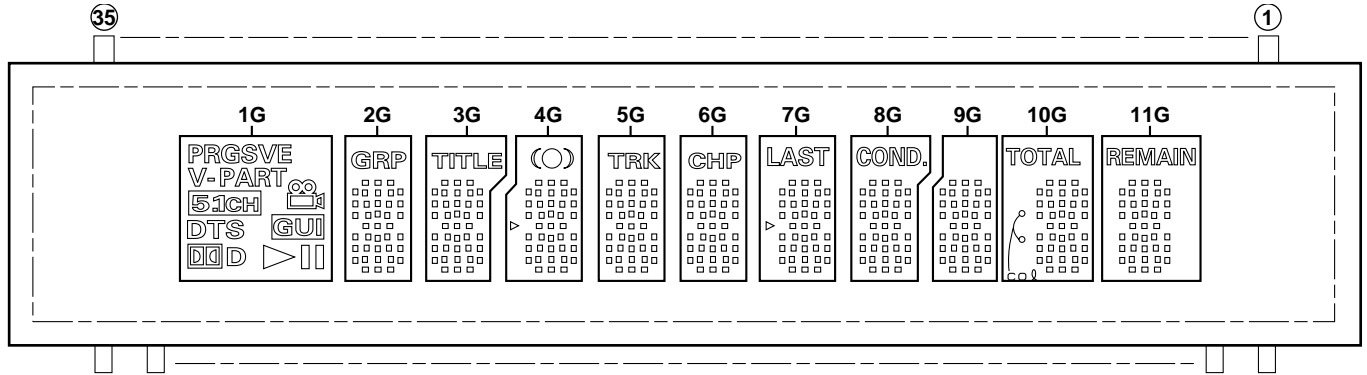

• Pin Connection

Pin No.	35	34	33	32	31	30	29	28	27	26	25	24	23	22	21	20	18	18
Connection	F2	F2	NP	P17	P16	P15	P14	P13	P12	P11	P10	NX	P9	P8	P7	P6	P5	P4
Pin No.	17	16	15	14	13	12	11	10	9	8	7	6	5	4	3	2	1	
Connection	P3	P2	P1	11G	10G	9G	8G	7G	6G	5G	4G	3G	2G	1G	NP	F1	F1	

- Note :
- 1) F1, F2 : Filament
 - 2) NP : No pin
 - 3) NX : No extend pin
 - 4) DL : Datum Line
 - 5) 1G - 11G : Grid

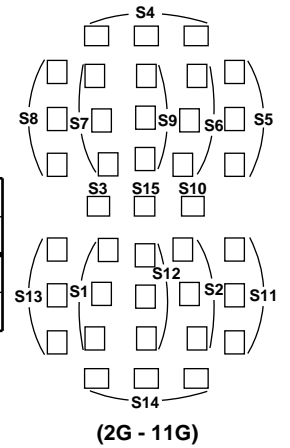

• Anode Connection

	1G	2G	3G	4G	5G	6G	7G	8G	9G	10G	11G
P1	PRGSVE	S1	S1	S1	S1	S1	S1	S1	S1	S1	S1
P2	V-PART	S2	S2	S2	S2	S2	S2	S2	S2	S2	S2
P3	51CH	S3	S3	S3	S3	S3	S3	S3	S3	S3	S3
P4	DTS	S4	S4	S4	S4	S4	S4	S4	S4	S4	S4
P5	GUI	S5	S5	S5	S5	S5	S5	S5	S5	S5	S5
P6	DDD	S6	S6	S6	S6	S6	S6	S6	S6	S6	S6
P7	▶	S7	S7	S7	S7	S7	S7	S7	S7	S7	S7
P8		S8	S8	S8	S8	S8	S8	S8	S8	S8	S8
P9	—	S9	S9	S9	S9	S9	S9	S9	S9	S9	S9
P10	—	S10	S10	S10	S10	S10	S10	S10	S10	S10	S10
P11	—	S11	S11	S11	S11	S11	S11	S11	S11	S11	S11
P12	—	S12	S12	S12	S12	S12	S12	S12	S12	S12	S12
P13	—	S13	S13	S13	S13	S13	S13	S13	S13	S13	S13
P14	—	S14	S14	S14	S14	S14	S14	S14	S14	S14	S14
P15	—	S15	S15	S15	S15	S15	S15	S15	S15	S15	S15
P16	—	—	—	▶	—	—	▶	—	—	col	—
P17	—	GRP	TITLE	(O)	TRK	CHP	LAST	COND.	—	TOTAL	REMAIN

8. PANEL FACILITIES AND SPECIFICATIONS

8.1 PANEL FACILITIES

■ Front Panel (DV-444)

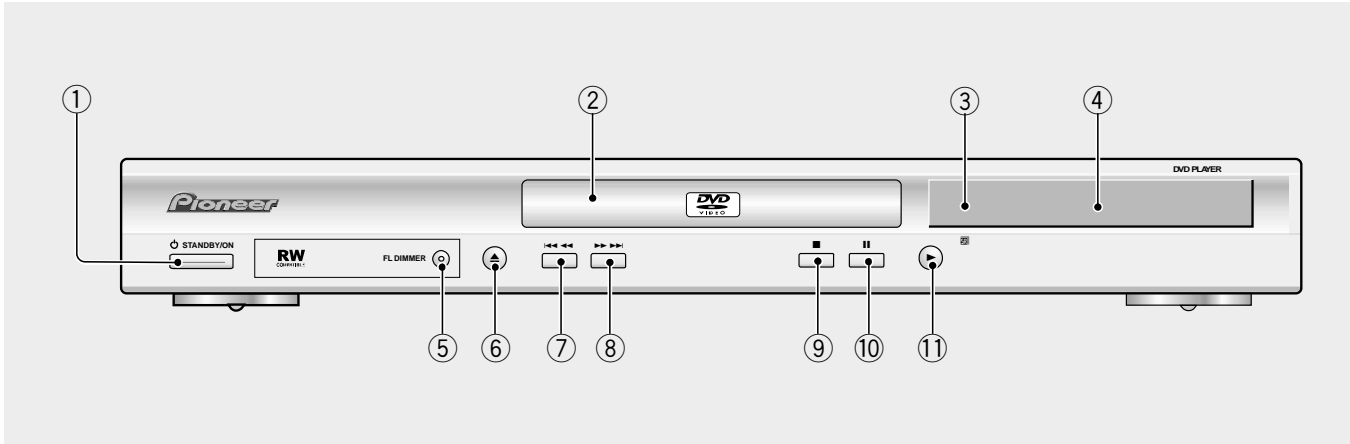

① **⏻ STANDBY/ON button**

Press to switch the player on or to put in standby.

② **Disc tray**

When loading a disc, place discs in the disc tray with the label side facing up.

③ **Remote sensor**

Point the remote control toward the remote sensor to operate the player.

④ **Display window**

Displays system information.

⑤ **FL DIMMER button and Indicator**

Press to change the brightness of the Display window and disc illumination in four steps: maximum brightness, medium brightness, minimum brightness, and off.

When the Display window is turned off, the indicator lights.

⑥ **▲ (open/close) button**

Press to open and close the disc tray.

⑦ **◀◀◀ (reverse) button**

Press to go back to previous chapters/tracks. Press and hold to perform reverse playback scanning.

⑧ **▶▶▶ (forward) button**

Press to advance to chapters/tracks. Press and hold to perform fast-forward scanning.

⑨ **■ (stop) button**

Press to stop playback. Pressing once enables playback to resume from a point shortly before the location where it stopped. Pressing twice causes the disc to return to the beginning of the disc if playback starts again.

⑩ **⏸ (pause) button**

Press during playback to pause. Press again to resume playback.

⑪ **▶ (play) button**

Press to start or resume playback.

■ Front Panel (DV-440)

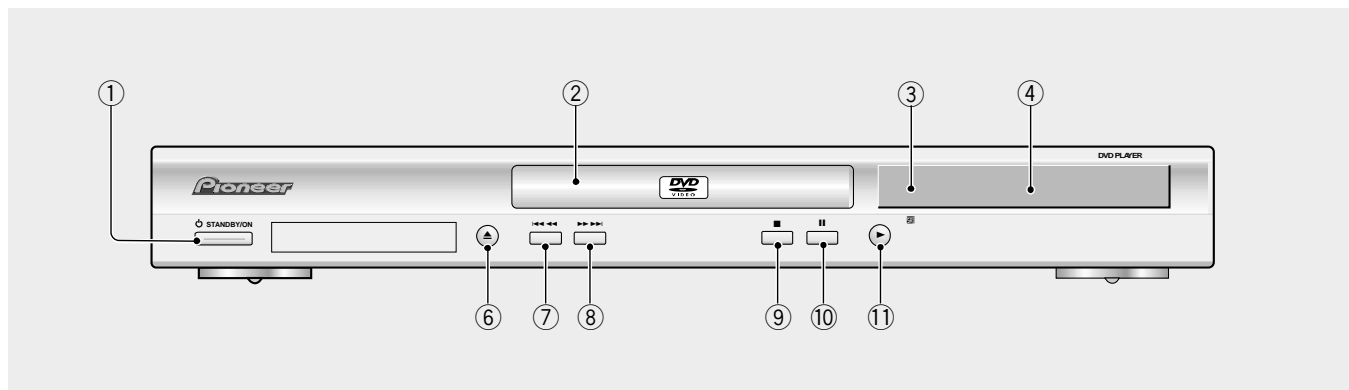

① **⏻ STANDBY/ON button**

Press to switch the player on or to put in standby.

② **Disc tray**

When loading a disc, place discs in the disc tray with the label side facing up.

③ **Remote sensor**

Point the remote control toward the remote sensor to operate the player.

④ **Display window**

Displays system information.

⑥ **⏏ (open/close) button**

Press to open and close the disc tray.

⑦ **⏮ ⏮ (reverse) button**

Press to go back to previous chapters/tracks. Press and hold to perform reverse playback scanning.

⑧ **⏭ ⏭ (forward) button**

Press to advance to chapters/tracks. Press and hold to perform fast-forward scanning.

⑨ **■ (stop) button**

Press to stop playback. Pressing once enables playback to resume from a point shortly before the location where it stopped. Pressing twice causes the disc to return to the beginning of the disc if playback starts again.

⑩ **⏸ (pause) button**

Press during playback to pause. Press again to resume playback.

⑪ **▶ (play) button**

Press to start or resume playback.

■ Display Window

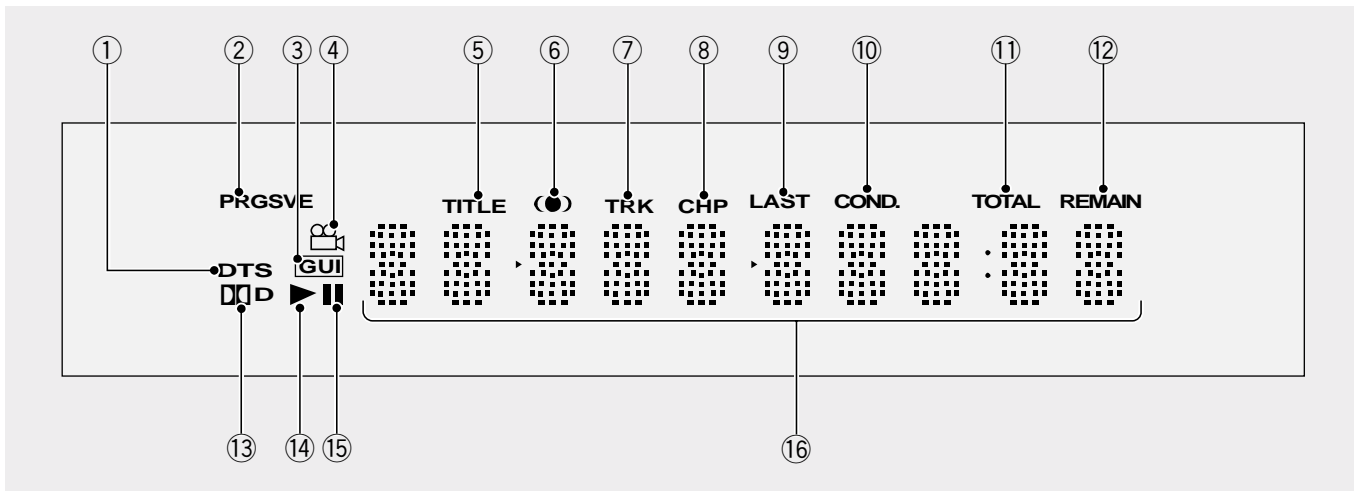

- ① **DTS indicator**
Indicates DTS audio playback.
- ② **PRGSVE indicator (DV-444 only)**
Lights when unit is set to output 525 line progressive scan (non-interlaced) video.
- ③ **GUI indicator**
Indicates an on-screen menu operation is being performed.
- ④ **Multi-Angle indicator**
Indicates Multi-Angle playback is in progress.
- ⑤ **TITLE indicator**
Indicates a title number is being displayed.
- ⑥ **(●) indicator**
Indicates that TruSurround is selected.
- ⑦ **TRK indicator**
Indicates a track number is being displayed.
- ⑧ **CHP indicator**
Indicates a chapter number is being displayed.
- ⑨ **LAST indicator**
Indicates the Last Memory location is recorded in memory for the currently loaded DVD or Video CD.
- ⑩ **COND. indicator**
Indicates that Condition Memory settings are memorized for the currently loaded DVD.
- ⑪ **TOTAL indicator**
Indicates that the disc in the player is stopped and **DISPLAY** has been pressed.
- ⑫ **REMAIN indicator**
Indicates that the remaining playback time of a title or chapter/track is being displayed.
- ⑬ **DDD indicator**
Indicates Dolby Digital audio playback.
- ⑭ **▶ indicators**
Indicates when a disc is playing.
- ⑮ **⏸ indicator**
Indicates when a disc is paused.
- ⑯ **Counter display**
Displays the playback mode, type of disc, title/folder and chapter/track numbers, playback time, etc.

Rear Panel

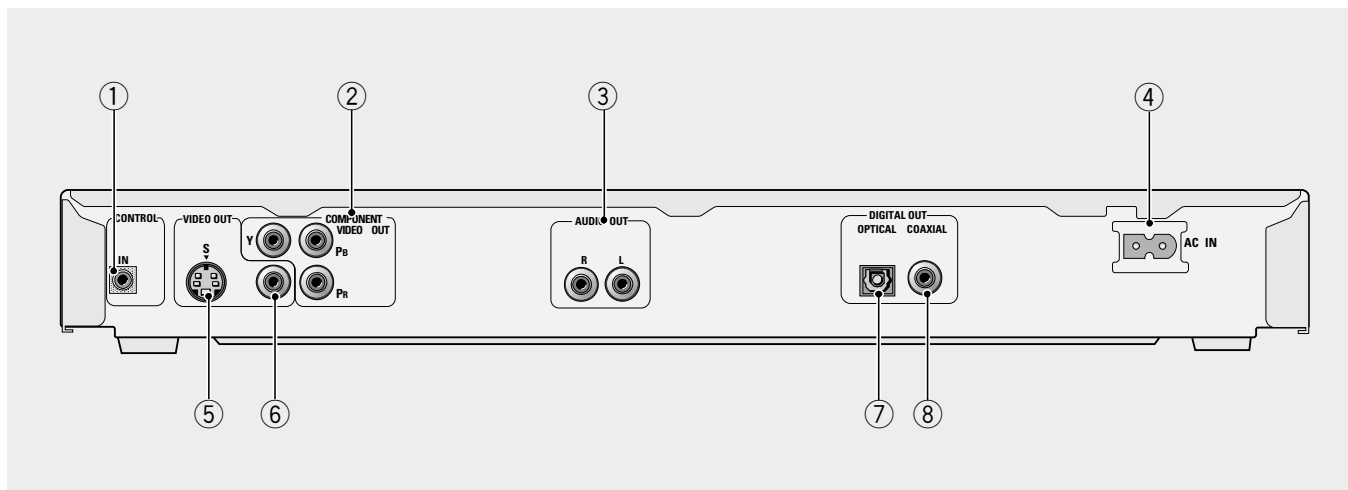

① CONTROL IN jack

Use to connect this player to another component bearing the Pioneer **SR** mark. This lets you control this unit as though it were a component in a system. Player operations are then performed by pointing the remote control at the component that the player is connect to.

② COMPONENT VIDEO OUT jacks

If your TV or monitor has component video inputs, you can produce a higher quality picture on your TV or monitor by connecting to the component video outputs on this unit.

③ AUDIO OUT jacks

Use to output two-channel audio (analog) to the audio stereo inputs on a TV or stereo amplifier. If you are connecting to a receiver that has both digital and analog input jacks for DVD player connection, it may be beneficial to make both connections.

④ AC IN power cord connection terminal

Use to connect the power cord to the wall outlet.

⑤ S-VIDEO OUT jack

If your TV or monitor has an S-video input, clear picture reproduction is possible by connecting the player to your TV or monitor via the S-Video jack.

You can switch between **[S1]** and **[S2]** S-video output from the Setup menu.

⑥ VIDEO OUT jack

Connect to the video input on a TV or monitor or AV amplifier or receiver with video input capability.

⑦ DIGITAL OUT OPTICAL jack

Use to output the digital audio signal recorded on discs. You can output the digital signal via the optical output jack to an AV amplifier or receiver.

⑧ DIGITAL OUT COAXIAL jack

Use to output the digital audio signal recorded on discs. You can output the digital signal via the coaxial output jack to an AV amplifier or receiver.

Remote Control Unit (DV-444)

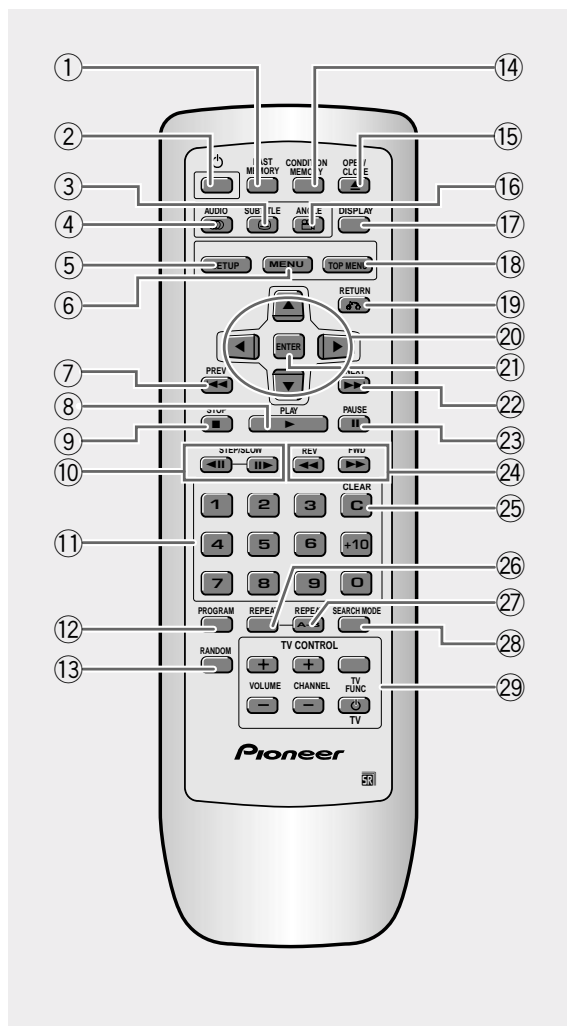

(Buttons indicated with * are used for menu operation.)

① **LAST MEMORY** button

You can resume DVD or Video CD playback from the point you last watched even if the disc is removed from the player. Press **LAST MEMORY** during playback to set a Last Memory point. When you want to resume playback of that disc, press **LAST MEMORY** in the stop mode and playback starts from the memorized point. Last Memory locations can be stored for up to 5 DVDs and 1 Video CD.

② **⏻ (standby/on)** button

Press to switch the player on or to put in standby.

③ **SUBTITLE** button

Press repeatedly to select one of the subtitle languages programmed on a DVD or to turn the subtitles off.

④ **AUDIO** button

Press repeatedly to select one of the audio languages programmed on a DVD.

For Video CD, CD and MP3, each press changes the audio output as follows.

→ Stereo → 1/L (Left) → 2/R (Right) →

⑤ **SETUP** button*

Press when the player is in either play or stop mode to open and close the Setup screen.

⑥ **MENU** button*

Use to display or close the DVD menu or MP3 Navigator screen.

⑦ **PREV** button

During playback, press **PREV** to go back to a previous chapter/track.

⑧ **PLAY** button

Press to start disc playback.

⑨ **STOP** button

Press to stop playback. Pressing once enables playback to resume from a point shortly before the location where it was stopped. Pressing twice causes the disc to return to the beginning of the disc when playback starts again.

⑩ **STEP/SLOW** buttons

Press **STEP/SLOW** during playback to view still frame. Press and hold **STEP/SLOW** during playback to view slow playback. In still frame, press **STEP/SLOW** to advance DVDs and Video CDs frame by frame and **STEP/SLOW** to back up a few frames at a time (DVD only).

⑪ **Number buttons (1-9, 0, +10)***

Use to perform direct title and chapter/track searches, and to input numerical values.

⑫ **PROGRAM** button

You can program titles, chapters, or tracks to play back in a desired order. Programs can be a maximum of 24 steps. Additionally, DVD programs for up to 24 discs can be stored in the player's memory for future use.

⑬ **RANDOM** button













Press to play titles, chapters/tracks in random order.

⑭ **CONDITION MEMORY** button

You can store in memory the settings for up to 15 DVDs. Press **CONDITION MEMORY** during DVD playback to memorize the settings.

⑮ **OPEN/CLOSE** button

Press to open or close the disc tray.

- ⑩⑥ **ANGLE  button**
Some DVDs are recorded with various camera angle playback options. Press **ANGLE ** repeatedly to display different camera angles.
- ⑩⑦ **DISPLAY button**
Press during playback to display statistical disc information. Press repeatedly to display different information.
- ⑩⑧ **TOP MENU button***
Press to call up the top menu programmed on the DVD. Depending on the DVD, the top menu may be identical to the DVD menu.
- ⑩⑨ **RETURN  button***
Use to go one menu back (current settings are maintained). Use **RETURN ** when you do not want to change the option setting in a menu.
- ⑩⑩ **Cursor buttons (/▶/▲/▼)***
Use to move through the options on menu screens and to change settings.
- ⑩⑪ **ENTER button***
Use to implement settings selected with the cursor buttons or to set items highlighted in a menu.
- ⑩⑫ **NEXT  button**
During playback, press **NEXT ** to advance to the next chapter/track.
- ⑩⑬ **PAUSE  button**
Press to pause playback of a disc. Press again to resume playback.
- ⑩⑭ **REV /FWD  (fast reverse/forward) buttons**
During playback of DVD and Video CD, press **FWD ** to perform fast forward scanning. Press **REV ** to perform fast reverse scanning of DVD and Video CD. When a CD or MP3 is loaded, audio scanning is performed.
- ⑩⑮ **CLEAR button**
Works in conjunction with a number of player functions. Use to cancel repeat and random playback, and to edit programs.
- ⑩⑯ **REPEAT button**
Use to set the repeat mode.
- ⑩⑰ **REPEAT A-B button**
Press at the beginning and end of the section you want to repeat or to mark a location you want to return to.
- ⑩⑱ **SEARCH MODE button**
Press to perform a title/folder, chapter/track or elapsed time search.

⑩⑲ **TV CONTROL buttons**

- TV FUNC:** Press TV FUNC to select the TV for remote control operation.
-  TV:** Press TV to turn the TV's power on or put in standby.
- CHANNEL:** Use to select TV channel.
- VOLUME:** Use to adjust the volume.

1. Input the maker code.

While holding down the **CLEAR** button, input the **twodigit** code from the table below that corresponds to the make of your TV.

For example, If you have a Pioneer TV, press and hold **CLEAR**, then press **0, 0** on the remote control.

2. Confirm that the TV is responding to the programmed code.

On the remote, press the ** TV** button. If the TV switches on (or into standby if it was on previously), then you have the correct code.

If nothing happens when you press the ** TV** button, start again from step 1 using a different code.

- Some makers have several codes. Try each one until you find the one that works.

Preset Code List

Code	Manufacturer	Code	Manufacturer
00	PIONEER 1	18	RCA 5
01	RCA 1	19	SHARP 1
02	SHARP 3	20	ZENITH 2
03	ZENITH 1	21	SANYO 1
04	SONY	22	PANASONIC 2
05	TOSHIBA 1	23	GOLDSTAR 2
06	HITACHI 1	24	HITACHI 2
07	PHILIPS	25	HITACHI 3
08	PANASONIC 1	26	TOSHIBA 2
09	MITSUBISHI	27	SHARP 2
10	GOLDSTAR 1	28	GE 2
11	GE 1	29	MAGNAVOX 2
12	MAGNAVOX 1	30	TOSHIBA 3
13	JVC 1	31	HITACHI 4
14	SANYO 2	32	JVC 2
15	RCA 2	33	FUJITSU
16	RCA 3	34	PIONEER 2
17	RCA 4	35	GRANDIENTE

Remote Control Unit (DV-440)

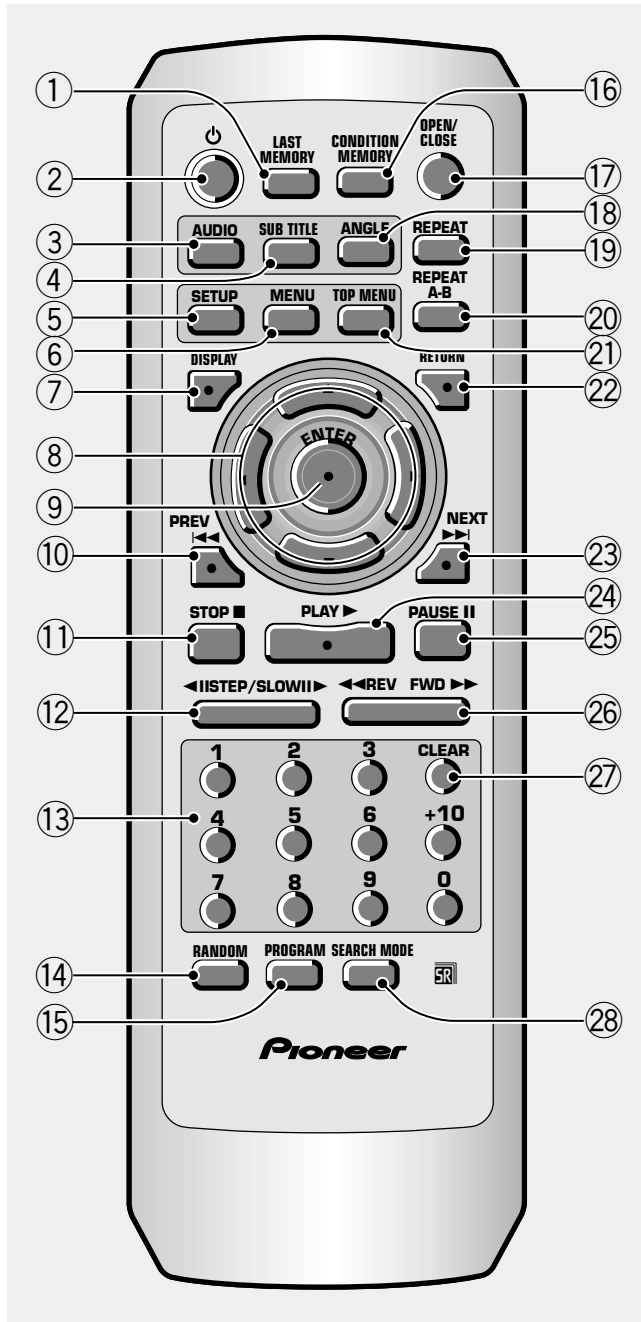

(Buttons indicated with * are used for menu operation.)

- ① **LAST MEMORY button**
You can resume DVD or Super VCD/Video CD playback from the point you last watched even if the disc is removed from the player. Press **LAST MEMORY** during playback to set a Last Memory point. When you want to resume playback of that disc, press **LAST MEMORY** in the stop mode and playback starts from the memorized point. Last Memory locations can be stored for up to 5 DVDs and 1 Super VCD/Video CD.
- ② **⏻ (standby/on) button**
Press to switch the player on or to put in standby.
- ③ **AUDIO button**
Press repeatedly to select one of the audio languages programmed on a DVD.
For Video CD, CD and MP3, each press changes the audio output as follows.

→ Stereo → 1/L (Left) → 2/R (Right)

For Super VCD, each press changes the audio output as follows.

→ 1 Stereo → 1L → 1R
2R ← 2L ← 2 Stereo ←
- ④ **SUBTITLE button**
Press repeatedly to select one of the subtitle languages programmed on a DVD or to turn the subtitles off.
- ⑤ **SETUP button***
Press when the player is in either play or stop mode to open and close the Setup screen.
- ⑥ **MENU button***
Use to display or close the DVD menu or MP3 Navigator screen.
- ⑦ **DISPLAY button**
Press during playback to display statistical disc information. Press repeatedly to display different information.
- ⑧ **Cursor buttons (◀/▶/▲/▼)***
Use to move through the options on menu screens and to change settings.
- ⑨ **ENTER button***
Use to implement settings selected with the cursor buttons or to set items highlighted in a menu.
- ⑩ **PREV ◀◀ (previous) button**
During playback, press **PREV ◀◀** to go back to a previous chapter/track.

- ⑪ **STOP ■ button**
Press to stop playback. Pressing once enables playback to resume from a point shortly before the location where it was stopped. Pressing twice causes the disc to return to the beginning of the disc when playback starts again.
- ⑫ **STEP/SLOW ◀II/II▶ buttons**
Press **STEP/SLOW ◀II or II▶** during playback to view still frame. Press and hold **STEP/SLOW ◀II or II▶** during playback to view slow playback. In still frame, press **STEP/SLOW II▶** to advance DVDs and Video CDs frame by frame and **STEP/SLOW ◀II** to back up a few frames at a time (DVD only).
- ⑬ **Number buttons (1-9, 0, +10)***
Use to perform direct title and chapter/track searches, and to input numerical values.
- ⑭ **RANDOM button**
Press to play title and chapters/tracks in random order.
- ⑮ **PROGRAM button**
You can program titles, chapters, or tracks to play back in a desired order. Programs can be a maximum of 24 steps. Additionally, DVD programs for up to 24 discs can be stored in the player's memory for future use.
- ⑯ **CONDITION MEMORY button**
You can store in memory the settings for up to 15 DVDs. Press **CONDITION MEMORY** during DVD playback to memorize the settings.
- ⑰ **OPEN/CLOSE button**
Press to open or close the disc tray.
- ⑱ **ANGLE button**
Some DVDs are recorded with various camera angle playback options. Press **ANGLE** repeatedly to display different camera angles.
- ⑲ **REPEAT button**
Use to set the repeat mode.
- ⑳ **REPEAT A-B button**
Press at the beginning and end of the section you want to repeat or to mark a location you want to return to.
- ㉑ **TOP MENU button***
Press to call up the top menu programmed on the DVD. Depending on the DVD, the top menu may be identical to the DVD menu.
- ㉒ **RETURN button***
Use to go one menu back (current settings are maintained). Use **RETURN** when you do not want to change the option setting in a menu.
- ㉓ **NEXT ▶▶I button**
During playback, press **NEXT ▶▶I** to advance to the next chapter/track.
- ㉔ **PLAY ▶ button**
Press to start or resume playback.
- ㉕ **PAUSE II button**
Press to pause playback of a disc. Press again to resume playback.
- ㉖ **REV ◀◀/FWD ▶▶ (fast reverse/forward) buttons**
During playback of DVD and Super VCD/Video CD, press **FWD ▶▶** to perform fast forward scanning. Press **REV ◀◀** to perform fast reverse scanning of DVD and Super VCD/Video CD. When a CD or MP3 is loaded, audio scanning is performed.
- ㉗ **CLEAR button**
Works in conjunction with a number of player functions. Use to cancel repeat and random playback, and to edit programs.
- ㉘ **SEARCH MODE button**
Press to perform a title/folder, chapter/track or elapsed time search.

8.2 SPECIFICATIONS

General

System	DVD, Video CD, CD, MP3 files
Power requirements	AC 120V, 60 Hz
Power consumption	12 W
Power consumption in standby mode	less than 1 W
Weight	2.6 kg (5 lb 12 oz)
Dimensions	420 (W) x 279 (D) x 55 (H) mm (16 ⁹ / ₁₆ (W) x 11(D) x 4 ³ / ₁₆ (H) in.) (Not including protruding cables, etc.)
Operating temperature	+5°C to +35°C (+36°F to +96°F)
Operating humidity	5% to 85% (no condensation)

S-Video output

Y (luminance) - Output level	1 Vp-p (75Ω)
C (color) - Output level	286 mVp-p (75Ω)
Jacks	S-VIDEO jack

Video output

Output level	1 Vp-p (75 Ω)
Jacks	RCA jack

Component video output

(Y, P _B , P _R)	
Output level	Y: 1.0 Vp-p (75 Ω) P _B , P _R : 0.7 Vp-p (75 Ω)
Jacks	RCA jacks

Audio output

Output level	
During audio output	200 mVrms (1 kHz, -20 dB)
Number of channels	2
Jacks	RCA jacks

Digital audio characteristics

Frequency response	4 Hz to 44 kHz (DVD fs: 96 kHz)
S/N ratio	118 dB
Dynamic range	103 dB
Total harmonic distortion	0.0016%
Wow and flutter	Limit of measurement (±0.001% W. PEAK) or lower

Digital output

Optical digital output	Optical digital jack
Coaxial digital output	RCA jack

Other terminals

CONTROL IN	Minijack (3.5 ø)
------------------	------------------

Accessories



Audio cord	1
Video cord	1
Power cord	1
Remote control unit	1
AA (R6P) dry cell batteries	2
Operating Instructions	1

Note

The specifications and design of this product are subject to change without notice, due to improvement.

- Manufactured under license from Dolby Laboratories. "Dolby" and the double-D symbol are trademarks of Dolby Laboratories. Confidential Unpublished Works, © 1992-1997 Dolby Laboratories. All rights reserved.
- "DTS" is a trademark of Digital Theater Systems, Inc.

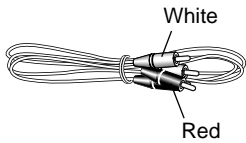
● Accessories

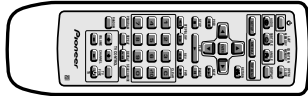
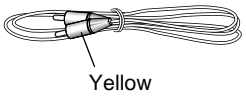
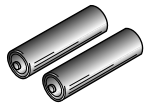
<ul style="list-style-type: none"> • Audio Cord (VDE1052 or VDE1054 or VDE1064) (L = 1.5m) 	<ul style="list-style-type: none"> • Power Cord (ADG7022) 	<ul style="list-style-type: none"> • Remote Control Unit (DV-444 : VXX2703) 
<ul style="list-style-type: none"> • Video Cord (VDE1053 or VDE1055 or VDE1065) (L = 1.5m) 	<ul style="list-style-type: none"> • Dry Cell Battery (R6P, AA) 	<ul style="list-style-type: none"> • Remote Control Unit (DV-440 : VXX2702) 