

Service Manual

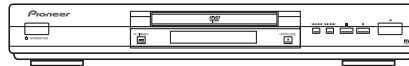

DV-565A-S

ORDER NO.
RRV2791

DVD PLAYER

DV-565A-S

DV-565A-K

THIS MANUAL IS APPLICABLE TO THE FOLLOWING MODEL(S) AND TYPE(S).

Model	Type	Power Requirement	Region No.	Serial No. Confirm 3rd & 4th alphabetical letters.
DV-565A-S	WYXU	AC220-240V	2	&&PG#####S
DV-565A-K	WYXU	AC220-240V	2	&&PG#####S



For details, refer to "Important symbols for good services".

SAFETY INFORMATION



This service manual is intended for qualified service technicians ; it is not meant for the casual do-it-yourselfer. Qualified technicians have the necessary test equipment and tools, and have been trained to properly and safely repair complex products such as those covered by this manual. Improperly performed repairs can adversely affect the safety and reliability of the product and may void the warranty. If you are not qualified to perform the repair of this product properly and safely, you should not risk trying to do so and refer the repair to a qualified service technician.

WARNING !

THE AEL (ACCESSIBLE EMISSION LEVEL) OF THE LASER POWER OUTPUT IS LESS THAN CLASS 1 BUT THE LASER COMPONENT IS CAPABLE OF EMITTING RADIATION EXCEEDING THE LIMIT FOR CLASS 1.

A SPECIALLY INSTRUCTED PERSON SHOULD DO SERVICING OPERATION OF THE APPARATUS.

LASER DIODE CHARACTERISTICS

FOR DVD : MAXIMUM OUTPUT POWER : 5 mW

WAVELENGTH : 650 nm

FOR CD : MAXIMUM OUTPUT POWER : 5 mW

WAVELENGTH : 780 nm

LABEL CHECK

CAUTION : VISIBLE AND INVISIBLE LASER RADIATION WHEN OPEN. AVOID EXPOSURE TO BEAM.

VORSICHT : SICHTBARE UND UNSICHTBARE LASERSTRAHLUNG. WENN ABDECKUNG GEÖFFNET NICHT DEM STRAHL AUSSETZEN!

ADVARSEL : SYNLIG OG USYNLIG LASERSTRÅLING VED ÅBNING UND GÅ UDSÆTTELSE FOR STRÅLING.

WARNING : SYNLIG OCH OSYNLIG LASERSTRÅLNING NÄR DENNA DEL ÄR ÖPPNAD BETRÄKTA EJ STRÅLEN.

VARO! : AVATTAESSA ALTISTUT NÄKYVÄ JA NÄKYMÄTTÖMÄLLE LASERSATEIL YLLE. ÄLÄ KATSO SÄTEESEN.

CAUIDADO : RADIACIÓN LASER VISIBLE E INVISIBLE AL ESTAR ABIERTO. EVITAR EXPOSICIÓN AL RAYO.

VRW1872

**CLASS 1
LASER PRODUCT**

(Printed on the Rear Panel)

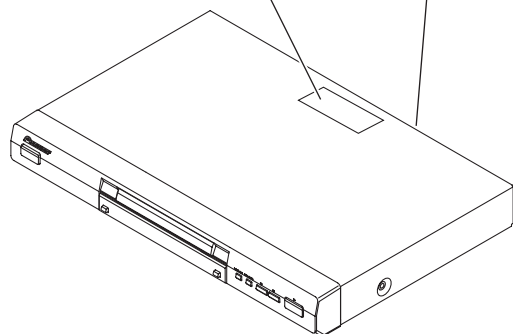

Additional Laser Caution

1. Laser Interlock Mechanism

- Loading switch (S101 on the LOAB Assy) is used for interlock mechanism of the laser.

When this switch turned ON in SW2 (CLOSE) side (OPEN signal is 0V and CLOSE signal is 3.5V), a laser becomes the status which can completely oscillation.

Furthermore, the laser completely oscillates in the disc judgment and disc playback.

When player is power ON state and laser diode is not completely oscillating, 780nm laser diode is always oscillating by half power.

- Laser diode is driving with Q201 (650nm LD) and Q211 (780nm LD) on the DVDM Assy.

Therefore, when short-circuit between the emitter and collector of these transistors or the base voltage is supplied for transistors turn on, the laser oscillates. (failure mode)

- In the test mode *, there is the mode that the laser oscillates except for the disc judgment and playback. LD ON mode in the test mode oscillates with the laser forcibly.

The interlock mechanism mentioned above becomes invalid in this mode.

2. When the cover is open, close viewing through the objective lens with the naked eye will cause exposure to the laser beam.

* : See page 51.

[Important symbols for good services]

In this manual, the symbols shown-below indicate that adjustments, settings or cleaning should be made securely. When you find the procedures bearing any of the symbols, be sure to fulfill them:

1. Product safety



You should conform to the regulations governing the product (safety, radio and noise, and other regulations), and should keep the safety during servicing by following the safety instructions described in this manual.

2. Adjustments



To keep the original performances of the product, optimum adjustments or specification confirmation is indispensable. In accordance with the procedures or instructions described in this manual, adjustments should be performed.

3. Cleaning



For optical pickups, tape-deck heads, lenses and mirrors used in projection monitors, and other parts requiring cleaning, proper cleaning should be performed to restore their performances.

4. Shipping mode and shipping screws



To protect the product from damages or failures that may be caused during transit, the shipping mode should be set or the shipping screws should be installed before shipping out in accordance with this manual, if necessary.

5. Lubricants, glues, and replacement parts



Appropriately applying grease or glue can maintain the product performances. But improper lubrication or applying glue may lead to failures or troubles in the product. By following the instructions in this manual, be sure to apply the prescribed grease or glue to proper portions by the appropriate amount. For replacement parts or tools, the prescribed ones should be used.

- *Manufactured under license from Dolby Laboratories. "Dolby" and the double-D symbol are trademarks of Dolby Laboratories.*
- *"DTS" and "DTS Digital Out" are registered trademarks of Digital Theater Systems, Inc.*
- *TruSurround and the (●) symbol are trademarks of SRS Labs, Inc. TruSurround technology is incorporated under license from SRS Labs, Inc.*

CONTENTS

	SAFETY INFORMATION	2
A	1. SPECIFICATIONS	5
	2. EXPLODED VIEWS AND PARTS LIST	6
	2.1 PACKING	6
	2.2 EXTERIOR SECTION.....	8
	2.3 FRONT PANEL SECTION	10
	2.4 LOADING MECHA ASSY	12
	2.5 TRAVERSE MECHA ASSY-S	14
	3. BLOCK DIAGRAM AND SCHEMATIC DIAGRAM	16
	3.1 BLOCK DIAGRAM	16
	3.2 LOAB ASSY and OVERALL WIRING DIAGRAM.....	18
	3.3 DVDM ASSY 1/3 [FRONT END BLOCK].....	20
	3.4 DVDM ASSY 2/3 [BACK END BLOCK].....	22
B	3.5 DVDM ASSY 3/3 [SACD and POWER SUPPLY BLOCK].....	24
	3.6 JCKB ASSY 1/2 [AUDIO BLOCK].....	26
	3.7 JCKB ASSY 2/2 [VIDEO BLOCK].....	28
	3.8 FLKY and PWSB ASSYS	30
	3.9 SCRIB ASSY	32
	3.10 POWER SUPPLY UNIT.....	34
	3.11 WAVEFORMS	35
	4. PCB CONNECTION DIAGRAM	37
	4.1 LOAB ASSY	37
	4.2 DVDM ASSY	38
	4.3 JCKB ASSY	40
	4.4 FLKY and PWSB ASSYS	42
C	4.5 POWER SUPPLY UNIT.....	44
	4.6 SCRIB ASSY	45
	5. PCB PARTS LIST	46
	6. ADJUSTMENT	49
	6.1 ADJUSTMENT ITEMS AND LOCATION	49
	6.2 JIGS AND MEASURING INSTRUMENTS.....	49
	6.3 NECESSARY ADJUSTMENT POINTS	50
	6.4 TEST MODE	51
	6.5 MECHANISM ADJUSTMENT	52
	7. GENERAL INFORMATION	54
	7.1 DIAGNOSIS	54
	7.1.1 TEST MODE	54
D	7.1.2 DISPLAY SPECIFICATION OF THE TEST MODE	56
	7.1.3 FUNCTIONAL SPECIFICATION OF THE SHORTCUT KEY.....	57
	7.1.4 SPECIFICATION OF MODEL INFORMATION DISPLAY.....	58
	7.1.5 FUNCTIONAL SPECIFICATION OF THE SERVICE MODE.....	59
	7.1.6 MECHANICAL ERROR HISTORY	60
	7.1.7 ID NUMBER AND ID DATA SETTING.....	63
	7.1.8 TROUBLE SHOOTING	66
	7.1.9 SEQUENCE AFTER POWER ON	68
	7.1.10 DISASSEMBLY	69
	7.2 IC	77
	7.3 DISC / CONTENT FORMAT PLAYBACK COMPATIBILITY	93
	7.4 CLEANING.....	95
E	8. PANEL FACILITIES	96

1. SPECIFICATIONS

General

System	DVD player
Power requirements	AC 220–240 V, 50/60 Hz
Power consumption	15 W
Power consumption (standby)	0.18 W
Weight	2.5 kg
Dimensions	420 (W) x 55 (H) x 283 (D) mm
Operating temperature	+5°C to +35°C (+41°F to +95°F)
Operating humidity	5% to 85% (no condensation)

AV connector output

AV Connector (21-pin connector assignment)
 AV connector output 21-pin connector
 This connector provides the video and audio signals for connection to a compatible colour TV or monitor.

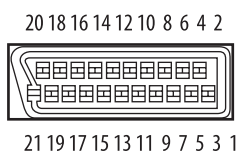

PIN no.

1	Audio 2/R out
3	Audio 1/L out
4	GND
7	B out
8	Status
11	G out
15	R or C out
17	GND
19	Video out or Y out
21	GND

Component video output

Y (luminance) - Output level	1 Vp-p (75 Ω)
P _B (color) - Output level	0.7 Vp-p (75 Ω)
P _R (color) - Output level	0.7 Vp-p (75 Ω)
Jack	RCA jacks

S-video output

Y (luminance) - Output level	1 Vp-p (75 Ω)
C (color) - Output level	286 mVp-p (75 Ω)
Jack	S-video jack

Video output

Output level	1 Vp-p (75 Ω)
Jack	RCA jack

Audio output (1 stereo pair)

Output level	During audio output 200 mVrms (1 kHz, -20 dB)
Number of channels	2
Jacks	RCA jack

Audio output (multi-channel / L, R, C, SW, LS, RS)

Output level	During audio output 200 mVrms (1 kHz, -20 dB)
Number of channels	6
Jacks	RCA jack

Digital audio characteristics

Frequency response	4 Hz to 44 kHz (DVD fs: 96 kHz) 4 Hz to 88 kHz (DVD-Audio fs: 192 kHz)
S/N ratio	118 dB
Dynamic range	108 dB
Total harmonic distortion	0.0014 %
Wow and flutter	Limit of measurement (±0.001% W. PEAK) or lower

Digital output

Optical digital output	Optical digital jack
Coaxial digital output	RCA jack

Other terminals

Control in	Minijack (3.5 ø)
Control out	Minijack (3.5 ø)

Accessories



Audio/video cable	1
Power cable	1
Remote control	1
AA/R6P dry cell batteries	2
Operating Instructions	3
Warranty card	1



Note

- The specifications and design of this product are subject to change without notice, due to improvement.

2. EXPLODED VIEWS AND PARTS LIST

- NOTES:
- Parts marked by "NSP" are generally unavailable because they are not in our Master Spare Parts List.
 - The  mark found on some component parts indicates the importance of the safety factor of the part. Therefore, when replacing, be sure to use parts of identical designation.
 - Screws adjacent to  mark on product are used for disassembly.
 - For the applying amount of lubricants or glue, follow the instructions in this manual.
(In the case of no amount instructions, apply as you think it appropriate.)

2.1 PACKING

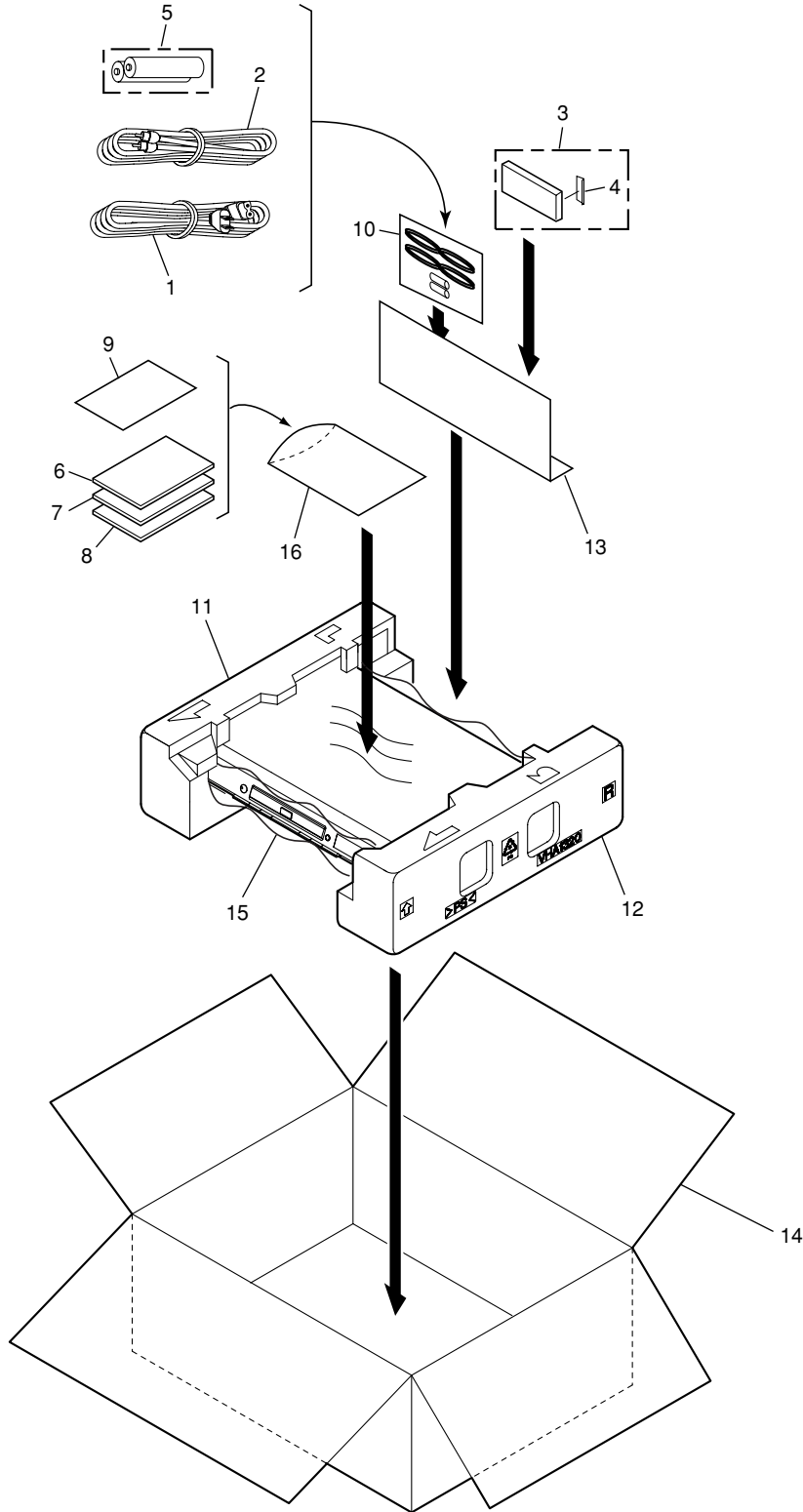

PACKING parts List

<u>Mark No.</u>	<u>Description</u>	<u>Part No.</u>	<u>Mark No.</u>	<u>Description</u>	<u>Part No.</u>
△ 1	Power Cable	ADG1127	11	Pad L	VHA1319
2	Audio / Video Cable	VDE1077	12	Pad R	VHA1320
3	Remote Control Unit	VXX2865	13	Paper Board	VHC1100
4	Battery Cover	VNK4997	14	Packing Case	See Contrast table (2)
NSP 5	Dry Cell Battery (R6P, AA)	VEM1030	15	Sheet (750 x 600 x 0.5)	Z23-007
6	Operating Instructions (English / Italian)	VRD1182	NSP 16	Polyethylene Bag	VHL1070
7	Operating Instructions (French / German)	VRD1183			
8	Operating Instructions (Spanish / Dutch)	VRD1184			
NSP 9	Warranty Card	ARY7065			
10	Polyethylene Bag	VHL1051			

(2) CONTRAST TABLE

DV-565A-S/WYXU and DV-565A-K/WYXU are constructed the same except for the following :

Mark	No.	Symbol and Description	DV-565A-S/ WYXU	DV-565A-K/ WYXU
	14	Packing Case	VHG2361	VHG2362

2.2 EXTERIOR SECTION

A

B

C

D

E

F

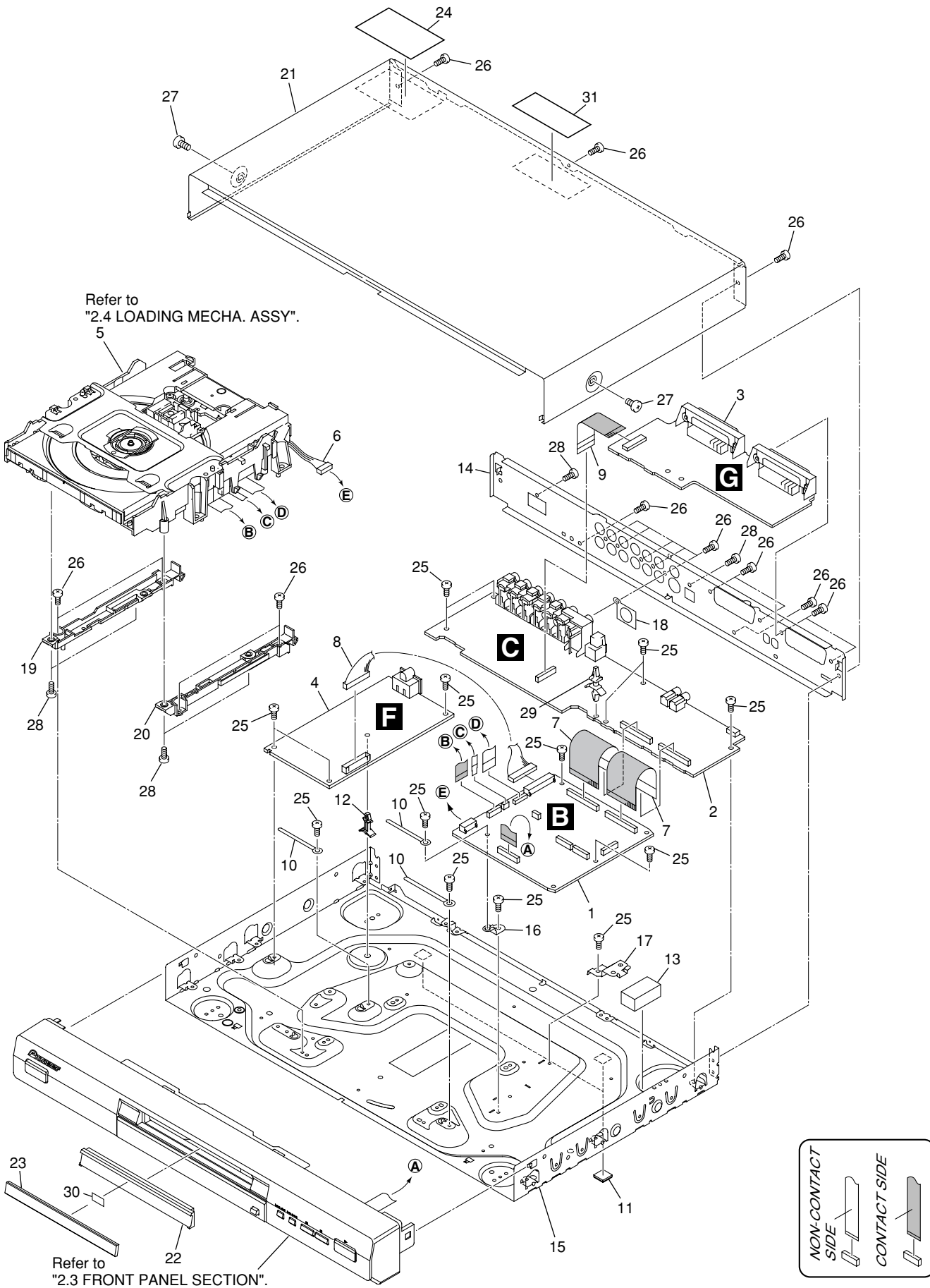

EXTERIOR SECTION parts List

<u>Mark No.</u>	<u>Description</u>	<u>Part No.</u>	<u>Mark No.</u>	<u>Description</u>	<u>Part No.</u>
1	DVDM Assy	VWS1563	16	PCB Base	VNE2278
2	JCKB Assy	VWV1944	17	PCB Base	VNE2310
3	SCRB Assy	VWV1939	NSP 18	S Earth Plate	VNF1128
 4	POWER SUPPLY Unit	VWR1366	19	Adapter 3L	VNL1960
NSP 5	Loading Mecha. Assy	VWT1207	20	Adapter 3R	VNL1961
6	Connector Assy	PG05KK-E37	21	Bonnet Case S	See Contrast table (2)
7	Flexible Cable (33P)	VDA1956	22	Tray Panel	See Contrast table (2)
8	Connector Assy (13P)	PF13PP-D27	23	Acryl Door	See Contrast table (2)
9	Flexible Cable (19P)	VDA1867	24	EURO Label	See Contrast table (2)
10	Cord Clamper	RNH-184	25	Screw	BBZ30P060FMC
11	Rubber Foot	VEB1349	26	Screw	BBZ30P080FZK
12	PCB Support	VEC2184	27	Screw	See Contrast table (2)
13	Cushion	VEC2342	28	Screw	PPZ30P080FMC
14	Rear Panel	See Contrast table (2)	NSP 29	PCB Holder	PNW2100
NSP 15	Base Chassis	VNA2614	30	Horogram Sheet	VEC2359
			31	Caution Label	VRW1872

(2) CONTRAST TABLE

DV-565A-S/WYXU and DV-565A-K/WYXU are constructed the same except for the following :

Mark	No.	Symbol and Description	DV-565A-S/ WYXU	DV-565A-K/ WYXU
	14	Rear Panel	VNA2580	VNA2577
	21	Bonnet Case S	VXX2874	VXX2873
	22	Tray Panel	VNK5280	VNK5281
	23	Acryl Door	VEC2333	VEC2334
	24	EURO Label	VRW1967	VRW1984
	27	Screw (for Bonnet Case S)	BCZ40P060FNI	BCZ40P060FZK

2.3 FRONT PANEL SECTION

A

B

C

D

E

F

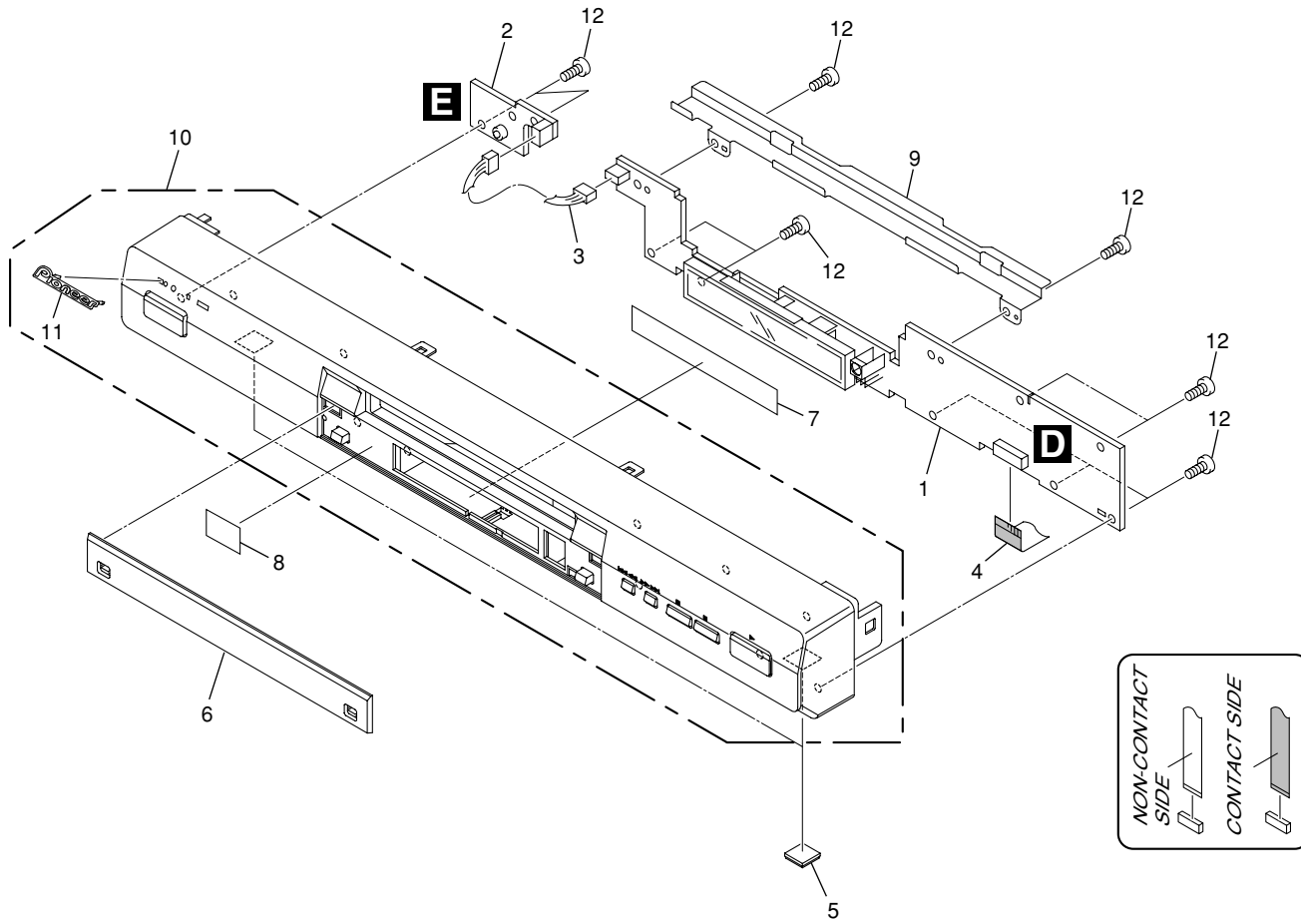

FRONT PANEL SECTION parts List

<u>Mark No.</u>	<u>Description</u>	<u>Part No.</u>	<u>Mark No.</u>	<u>Description</u>	<u>Part No.</u>
1	FLKY Assy	VWG2428	11	Pioneer Name Plate	See Contrast table (2)
NSP 2	PWSB Assy	VWG2429	12	Screw	PPZ30P080FMC
3	Connector Assy	PF03PP-B07			
4	Flexible Cable (21P)	VDA1957			
5	Rubber Foot	VEB1349			
6	FL Lens	VEC2337			
7	FL Filter	VEC2339			
8	Hologram Label	ARW7239			
9	FP Angle	VNE2300			
10	Front Panel Assy	See Contrast table (2)			

(2) CONTRAST TABLE

DV-565A-S/WYXU and DV-565A-K/WYXU are constructed the same except for the following :

Mark	No.	Symbol and Description	DV-565A-S/ WYXU	DV-565A-K/ WYXU
	10	Front Panel Assy	VXA2581	VXA2582
	11	Pioneer Name Plate	VAM1129	VAM1130

2.4 LOADING MECHA ASSY

Note :



Refer to
"Application of Lubricant".

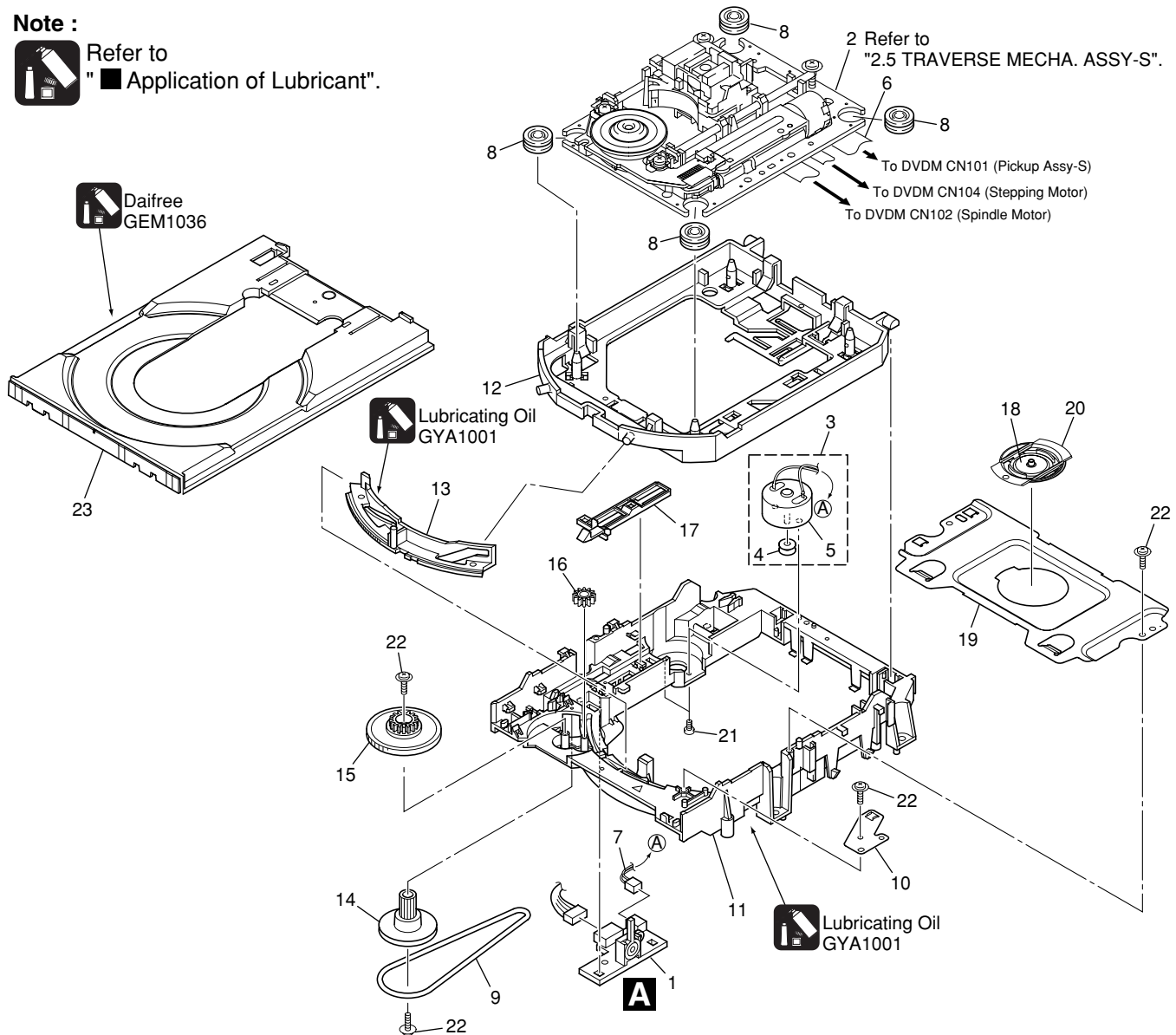

LOADING MECHA ASSY parts List

Mark No.	Description	Part No.	Mark No.	Description	Part No.
NSP 1	LOAB Assy	VWG2426	17	SW Lever	VNL1925
2	Traverse Mecha. Assy-S	VXX2871	18	Clamper Plate	VNE2251
3	Loading Motor Assy	VXX2872	19	Bridge	VNE2252
4	Motor Pulley	PNW1634	20	Clamper	VNL1924
5	Motor	VXM1105	21	Screw	JGZ17P028FMC
6	Flexible Cable (24P)	VDA1945	22	Screw	Z39-019
7	Connector Assy 2P	VKP2253	23	Tray	VNL1920
8	Floating Rubber	VEB1351			
9	Belt	VEB1330			
10	Stabilizer	VNE2253			
11	Loading Base	VNL1917			
12	Float Base DVD	VNL1918			
13	Drive Cam	VNL1919			
14	Gear Pulley	VNL1921			
15	Loading Gear	VNL1922			
16	Drive Gear	VNL1923			

Application of Lubricant

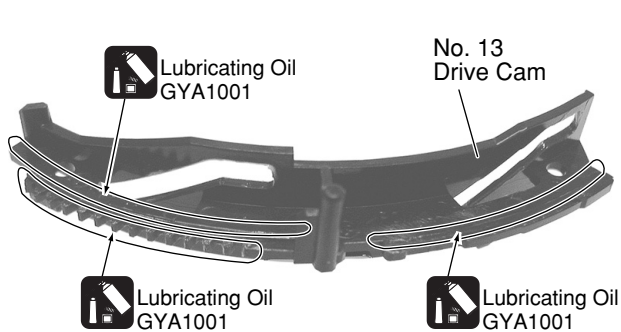
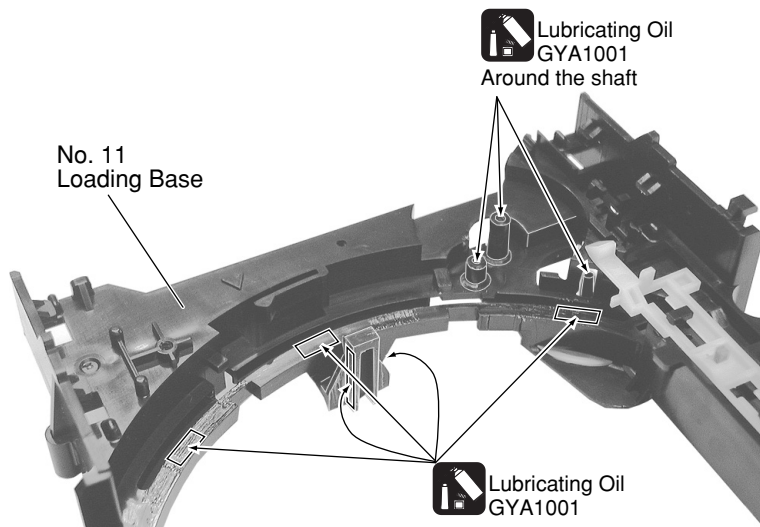

● Front View

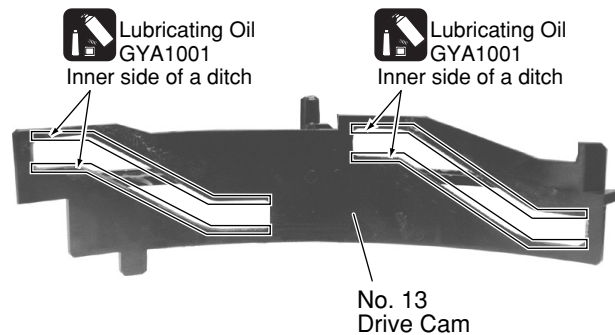

● Rear View

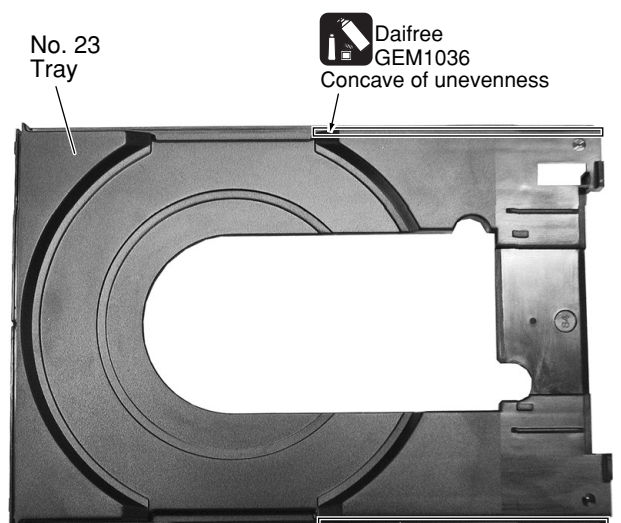

● Top View

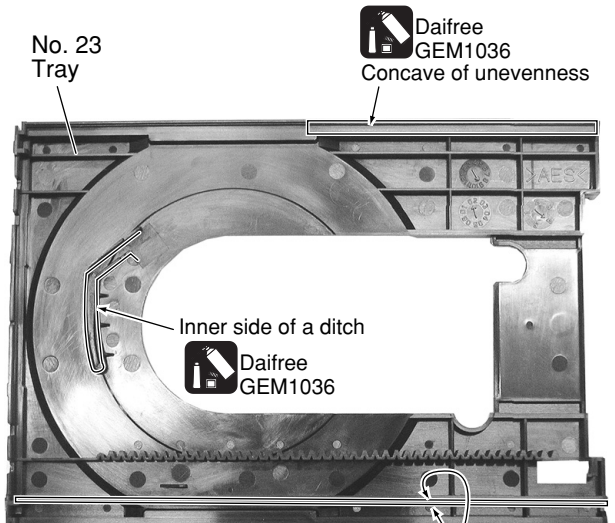

● Bottom View

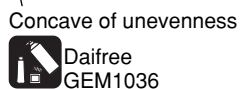

2.5 TRAVERSE MECHA ASSY-S

A
B
C
D
E
F

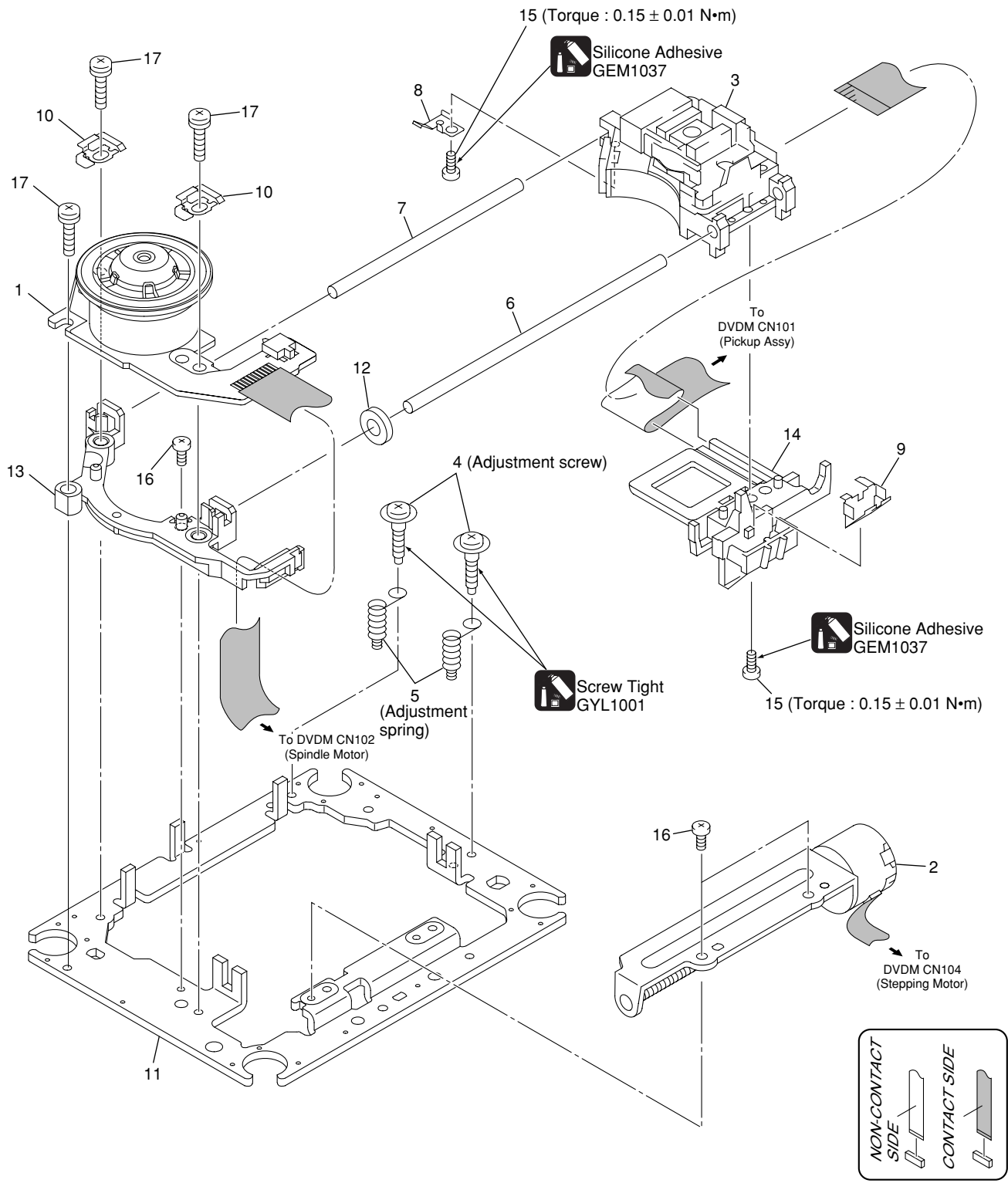

TRAVERSE MECHA ASSY-S parts List

<u>Mark No.</u>	<u>Description</u>	<u>Part No.</u>
1	Spindle Motor	VXM1099
2	Stepping Motor	VXM1101
3	Pickup Assy-S	OXX8005
4	Skew Screw	VBA1080
5	Skew Spring	VBH1335
6	Guide Bar	VLL1514
7	Sub Guide Bar	VLL1515
8	Leaf Spring	VNC1023
9	Joint Spring	VNC1019
10	Support Spring	VNC1020
NSP 11	Mecha.Chassis	VNE2248
12	Damper Sheet	VEB1335
13	Spacer	VNL1913
14	Joint 03	VNL1949
15	Tapping Screw	OBA8021
16	Screw	BBZ20P050FZK
17	Screw	PMA26P100FMC

A

B

C

D

E

F

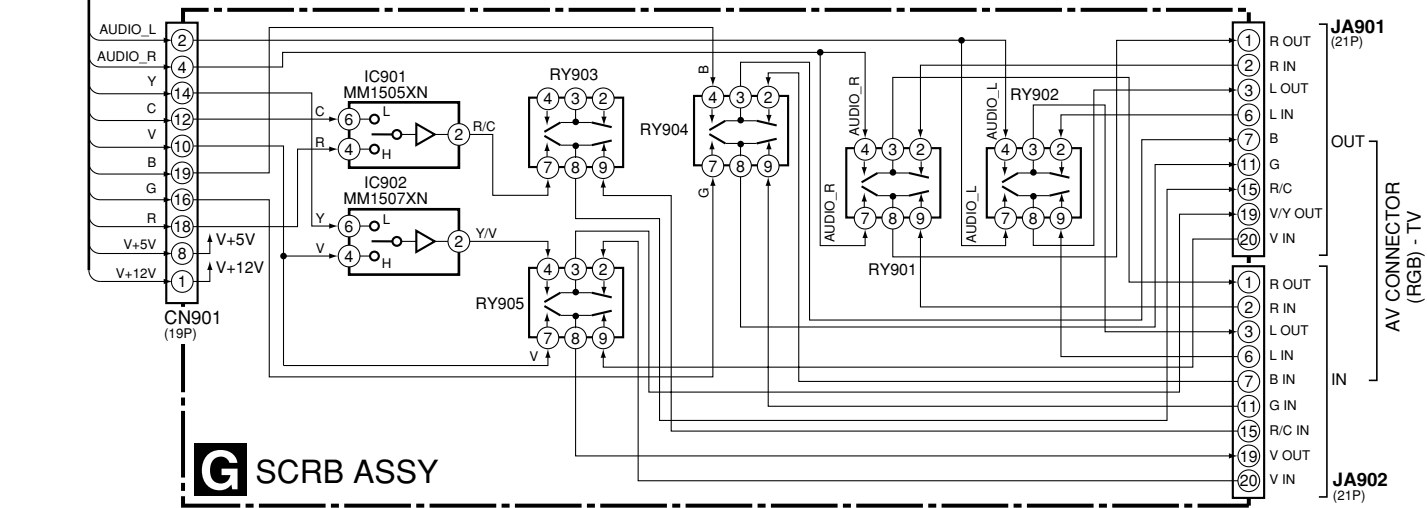
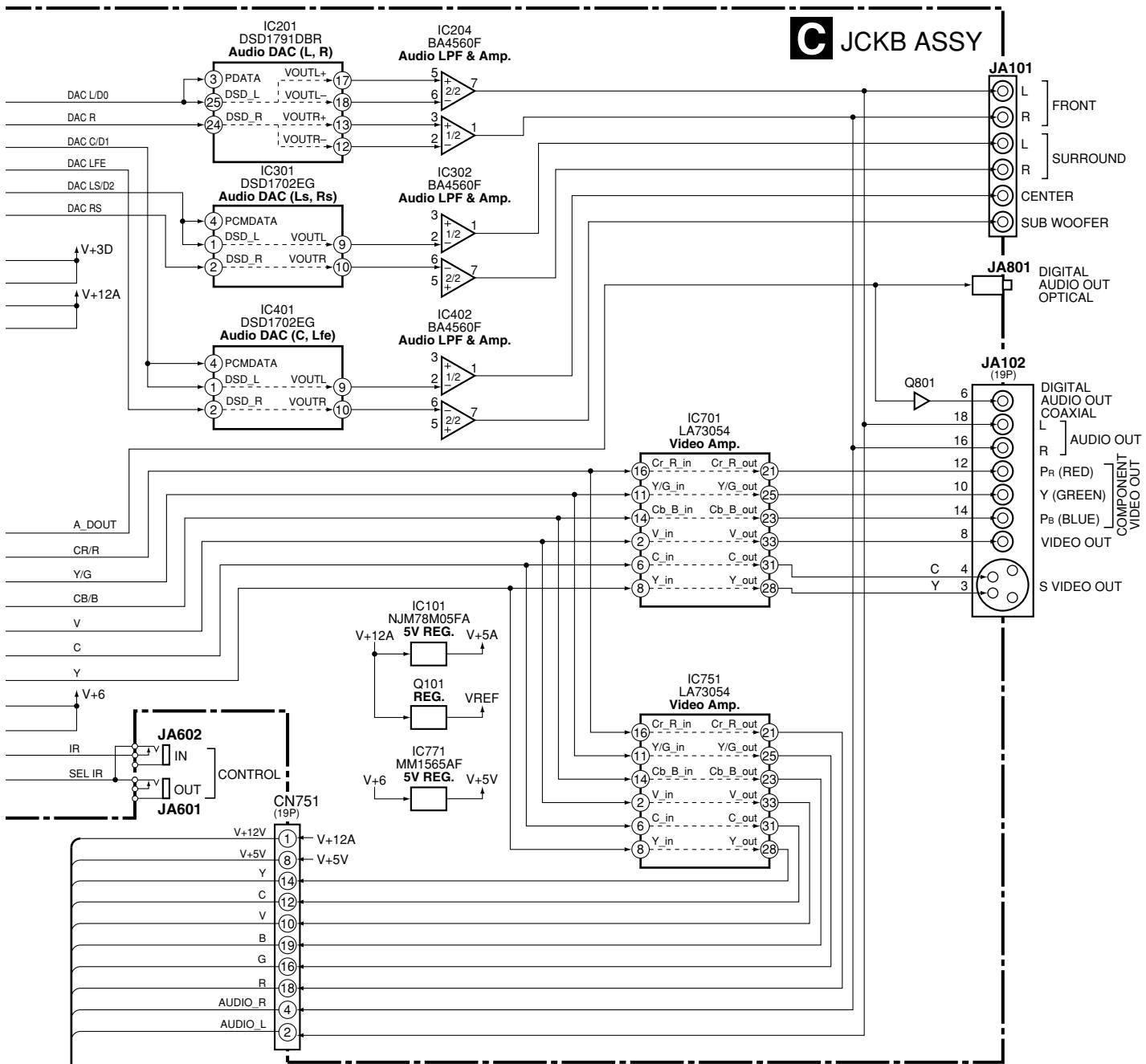

G SCRBS ASSY

C JCKB ASSY

3.2 LOAB ASSY and OVERALL WIRING DIAGRAM

A

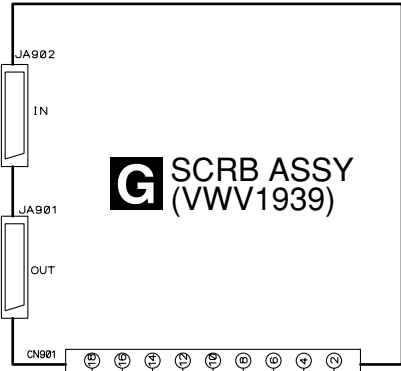

Note : When ordering service parts, be sure to refer to "EXPLODED VIEWS and PARTS LIST" or "PCB PARTS LIST".

B

C

D

E

F

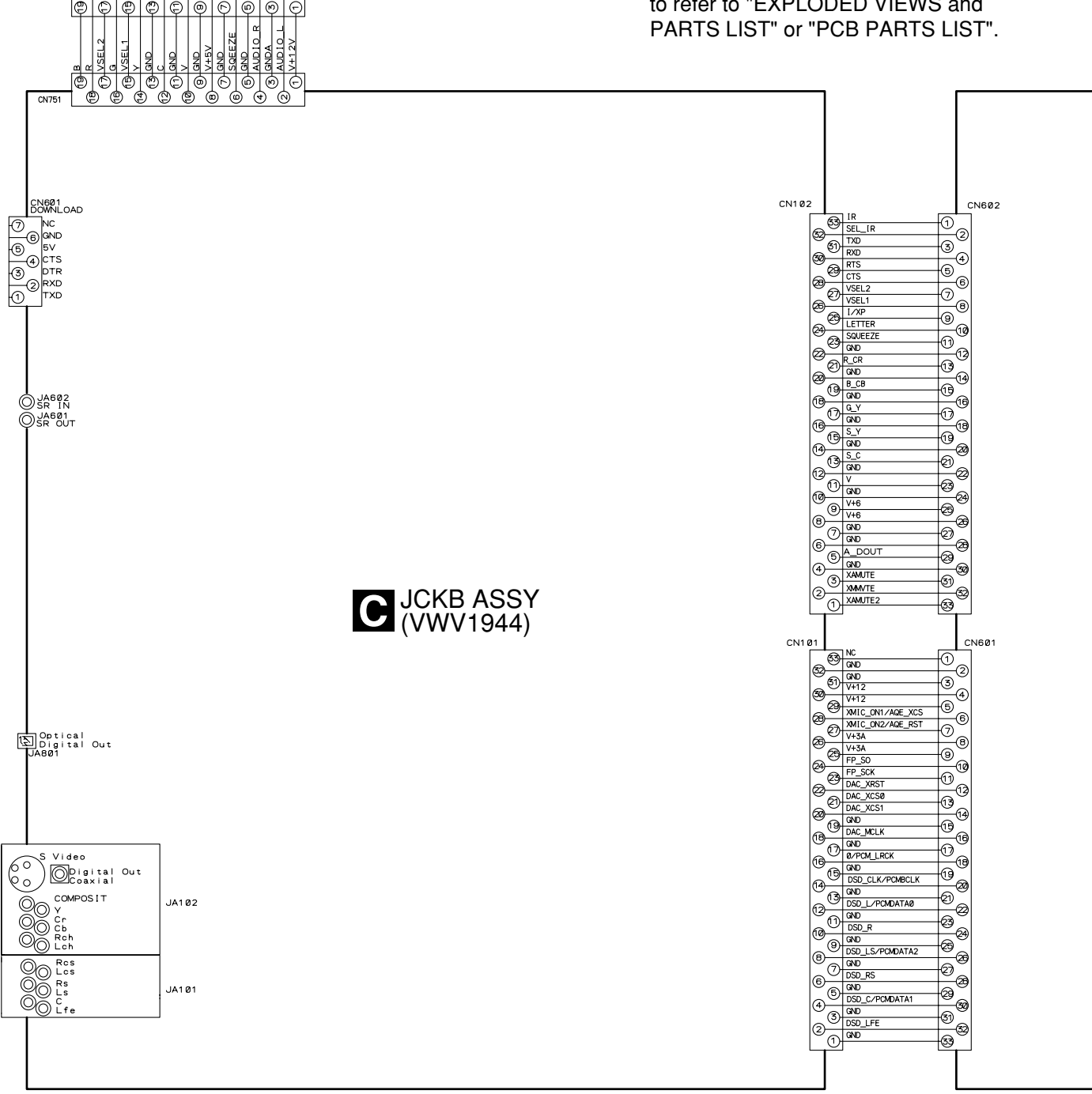

RF → : RF SIGNAL ROUTE

- (F) : FOCUS SERVO LOOP LINE
- (T) : TRACKING SERVO LOOP LINE
- (S) : STEPPING SERVO LOOP LINE

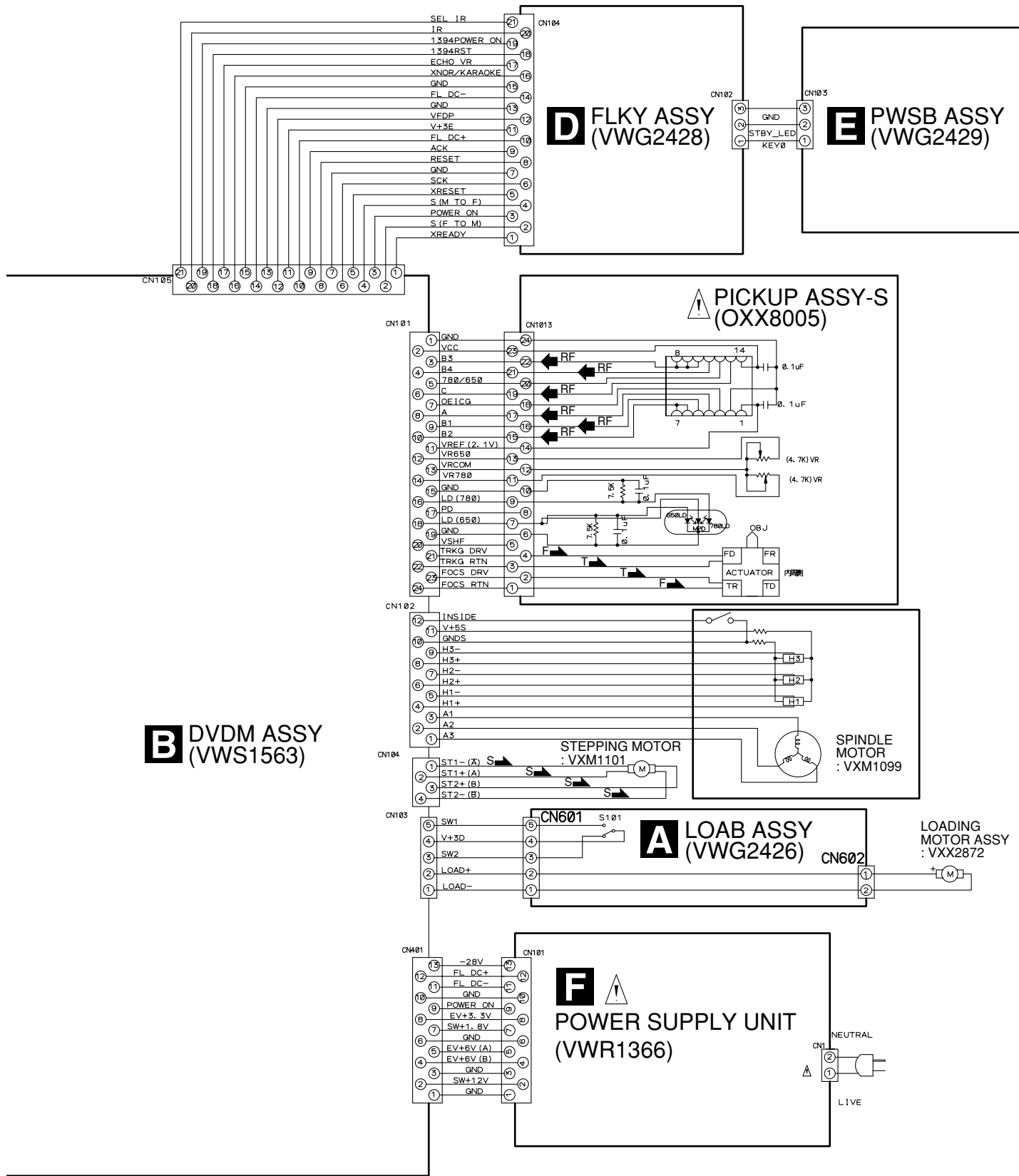

△の部品は、指定部品（安全規格適合部品）を必ず使用すること。
 Part marked Triangle Sign shall be replaced with the same part.
 (safety regulation authorized)



3.3 DVDM ASSY 1/3 [FRONT END BLOCK]

B 1/3 DVDM ASSY (VWS1563)

STEPPING MOTOR

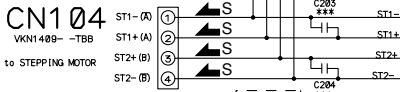

A
CN601

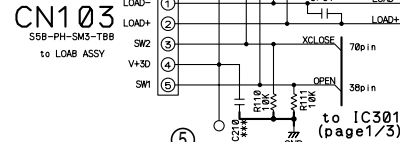

SPINDLE MOTOR

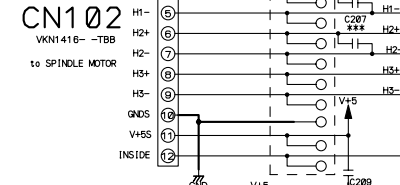

PICKUP ASSY-S

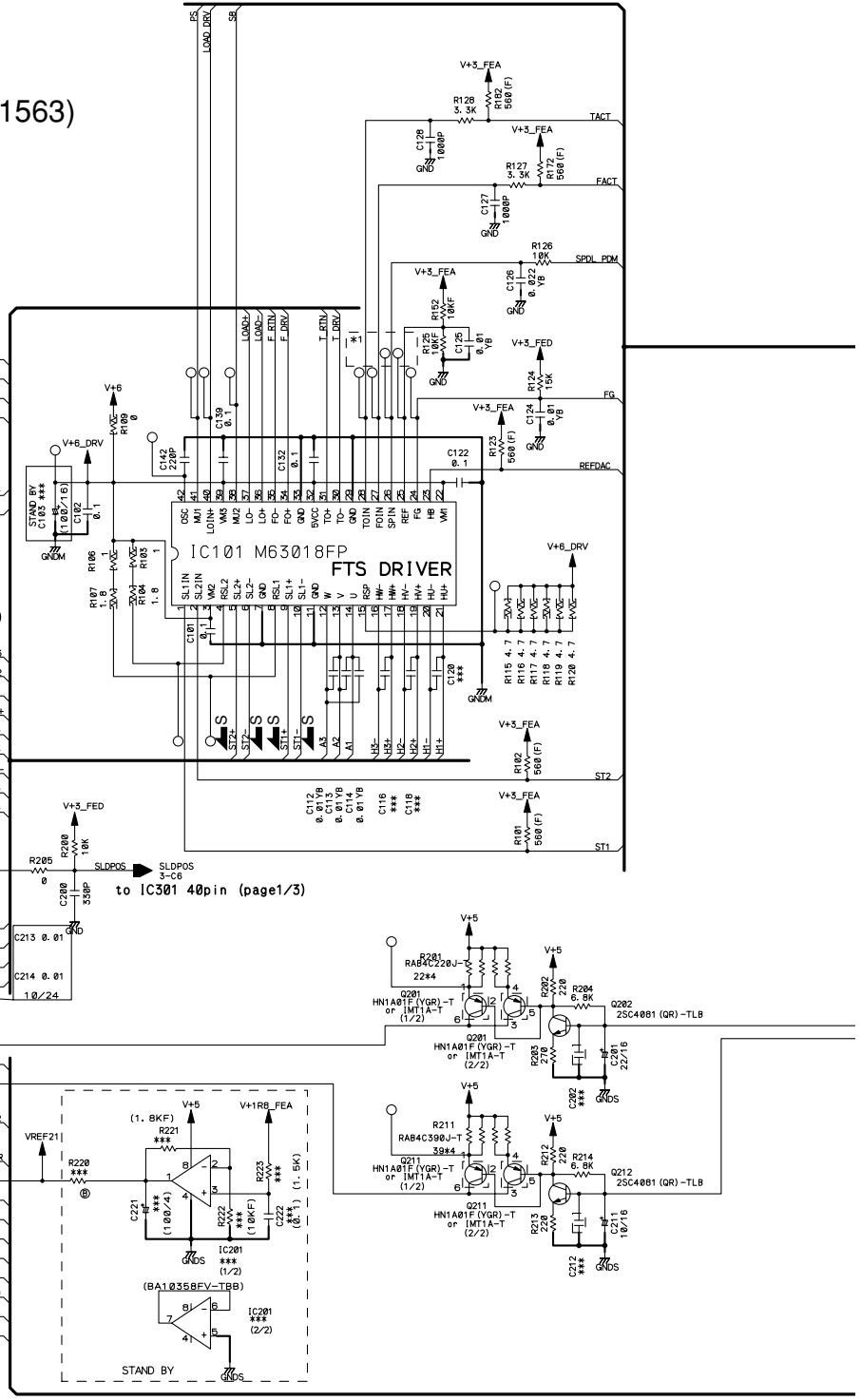
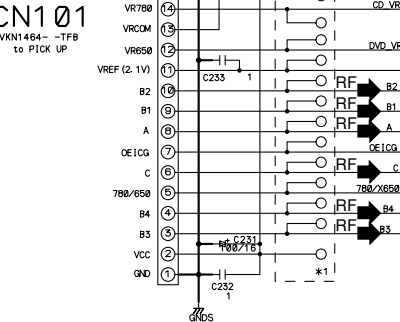

- RF : RF SIGNAL ROUTE
- : FE_DATA SIGNAL ROUTE
- F : FOCUS SERVO LOOP LINE
- T : TRACKING SERVO LOOP LINE
- S : STEPPING SERVO LOOP LINE

①-⑤: Refer to "3.11 WAVEFORMS".

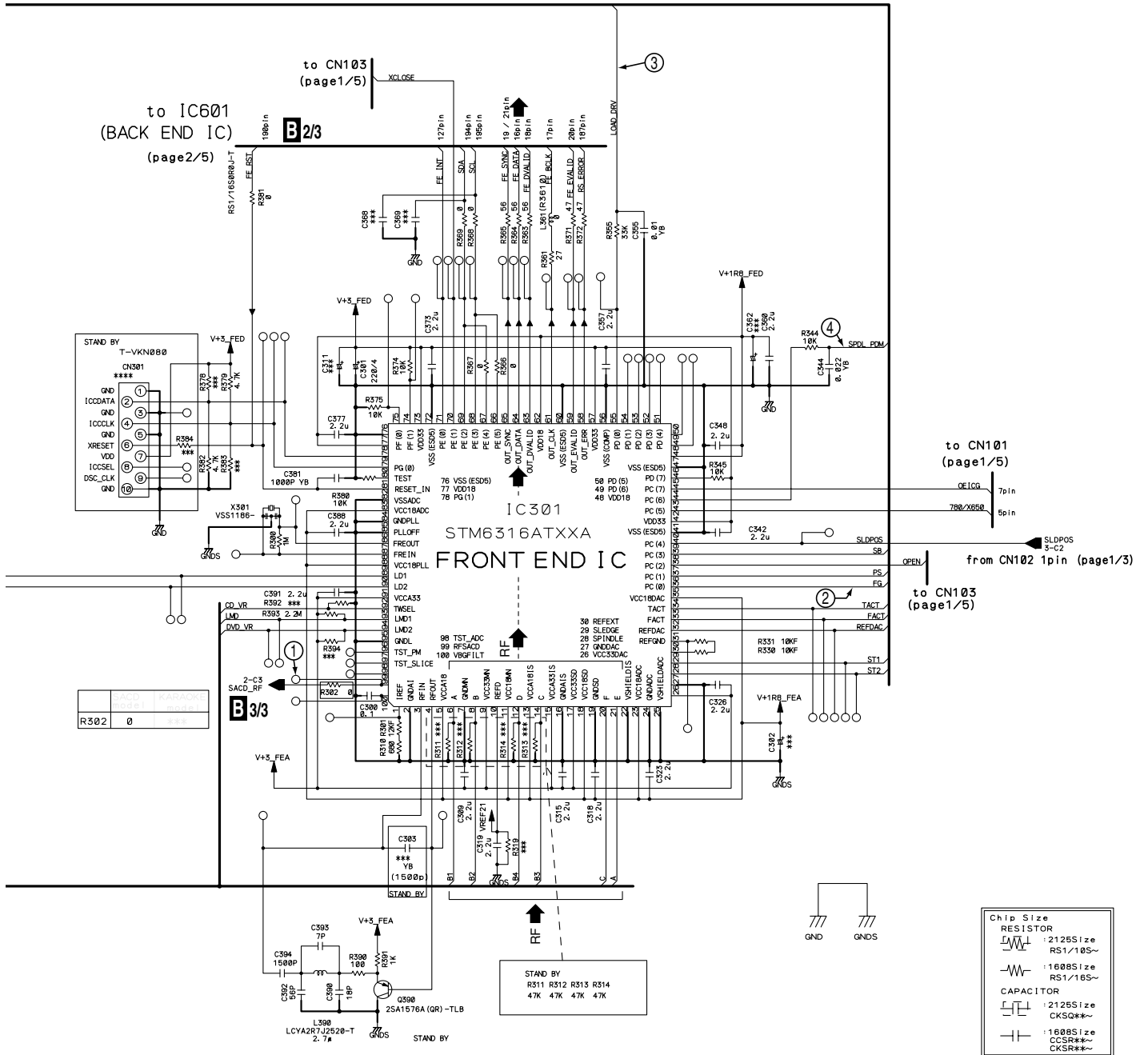

***: parts not mounted

B 1/3

3.4 DVDM ASSY 2/3 [BACK END BLOCK]

B 2/3 DVDM ASSY (VWS1563)

A

B

C

D

E

F

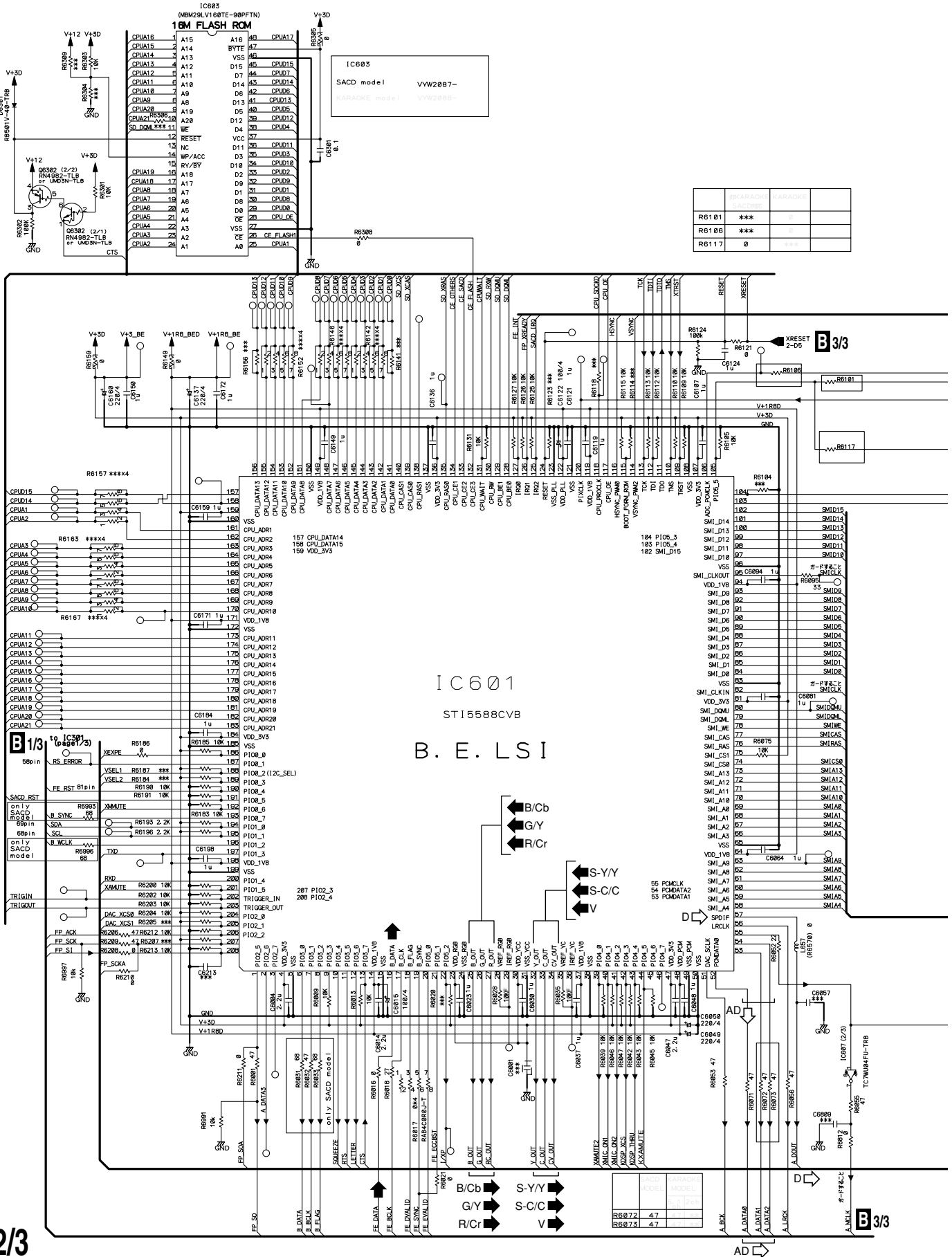

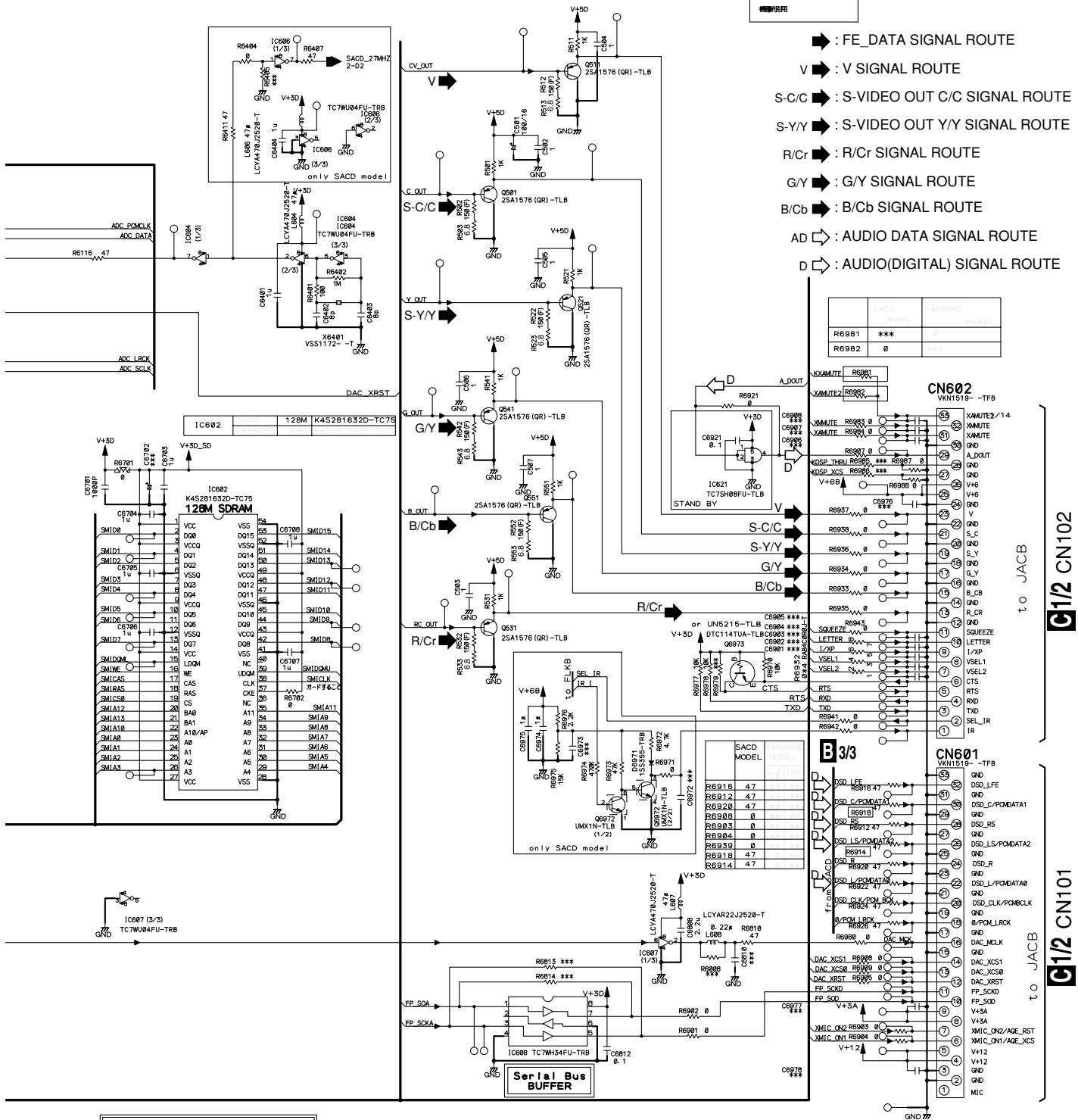

Chip Size	CAPACITOR
RESISTOR : 2125Size RS1/18S~	: 2125Size CKSQ~
: 1608Size CSR~	: 1608Size CKS~
: 1608Size RS1/18S~	

CN602
VKN1519-TFB
to JACB

CN601
VKN1519-TFB
to JACB

3.5 DVDM ASSY 3/3 [SACD and POWER SUPPLY BLOCK]

B 3/3 DVDM ASSY (VWS1563)

AD ⇨ : AUDIO DATA SIGNAL ROUTE
 D ⇨ : AUDIO(DIGITAL) SIGNAL ROUTE

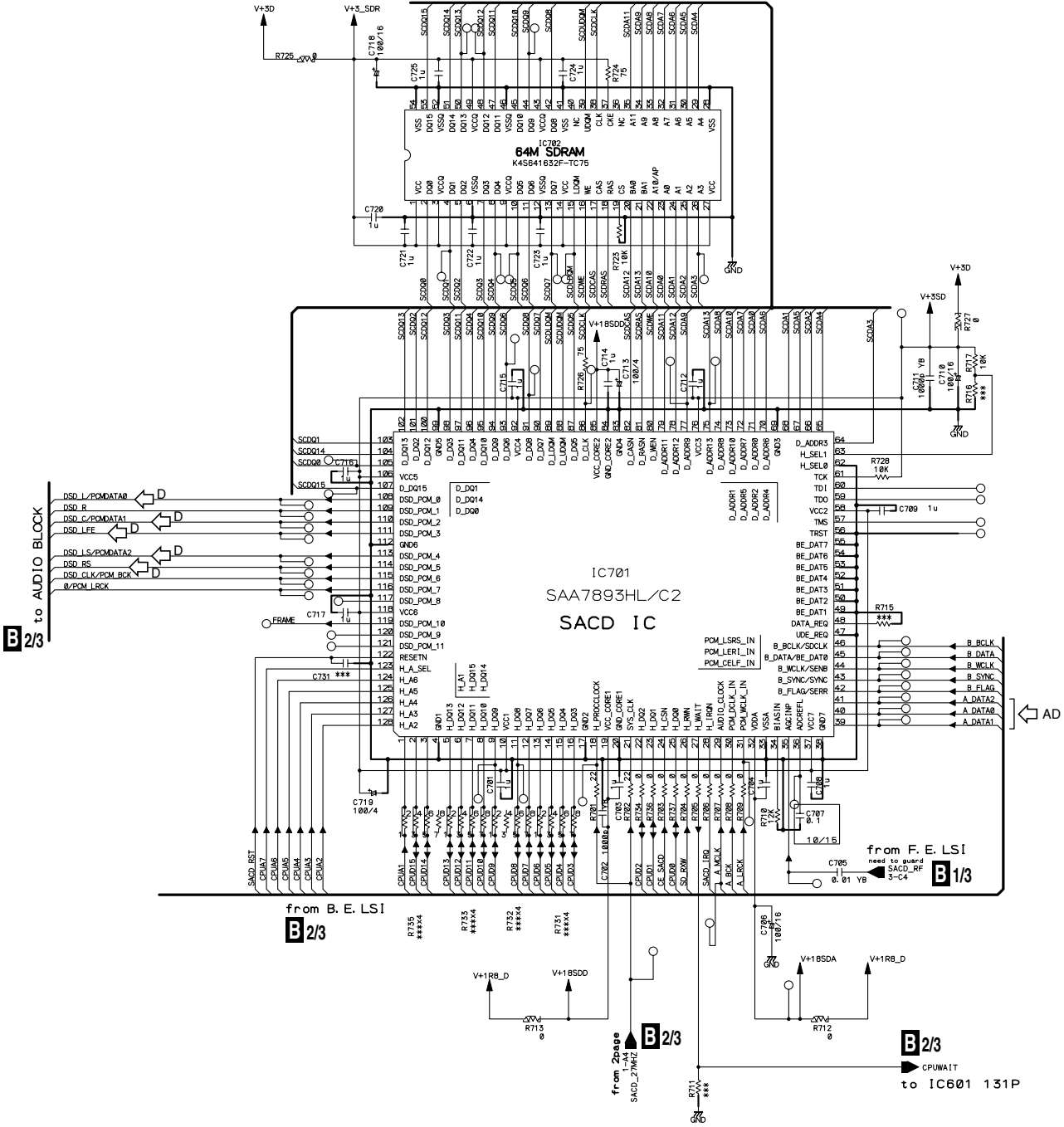

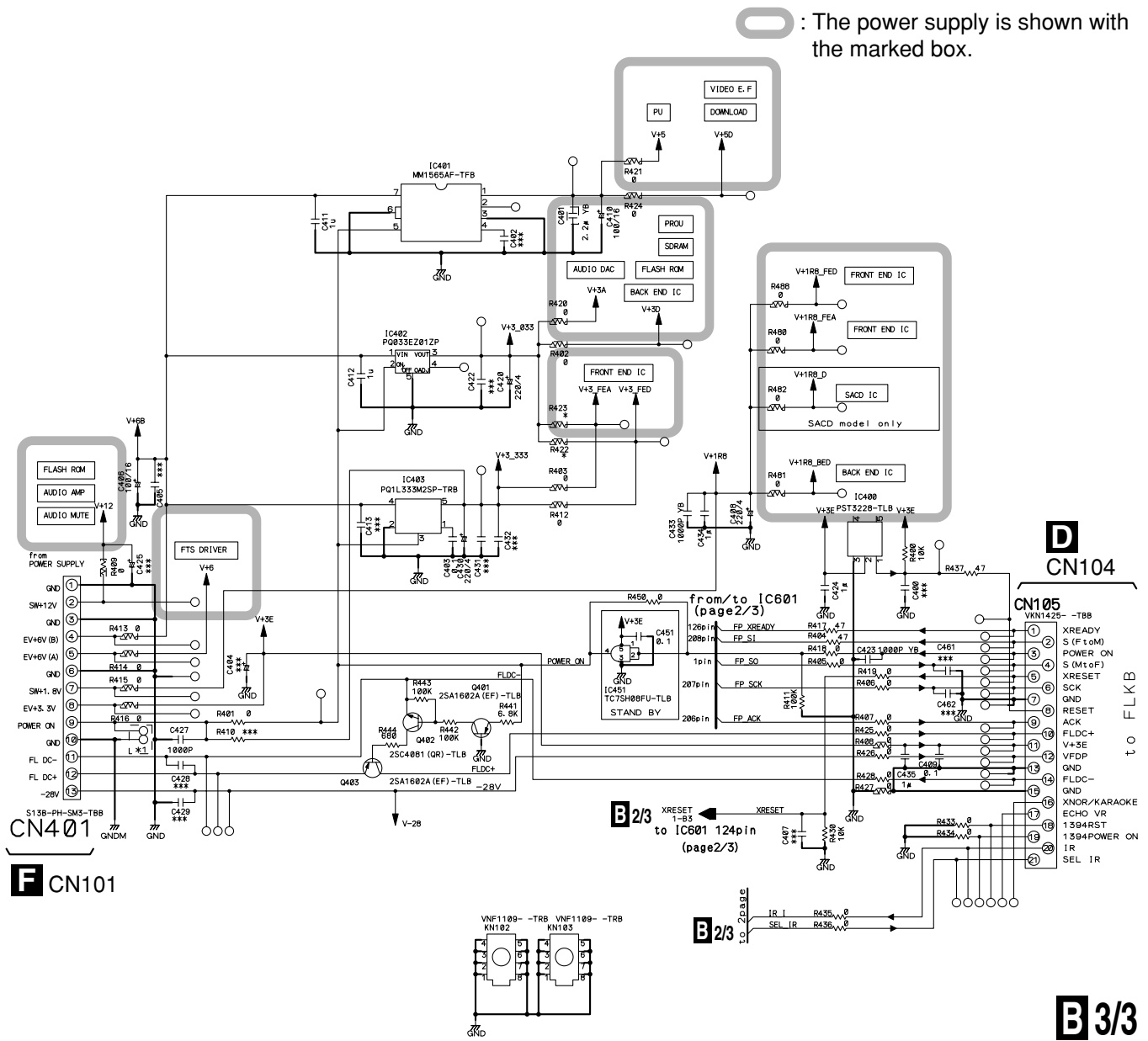

 : The power supply is shown with the marked box.

A
B
C
D
E
F

CN401
F CN101

B 2/3 XRESET 1-BX to IC601 124pin (page 2/3)

B 2/3 IR I SEL IR

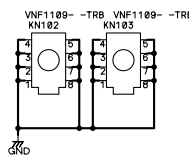

DV-565A-S

B 3/3





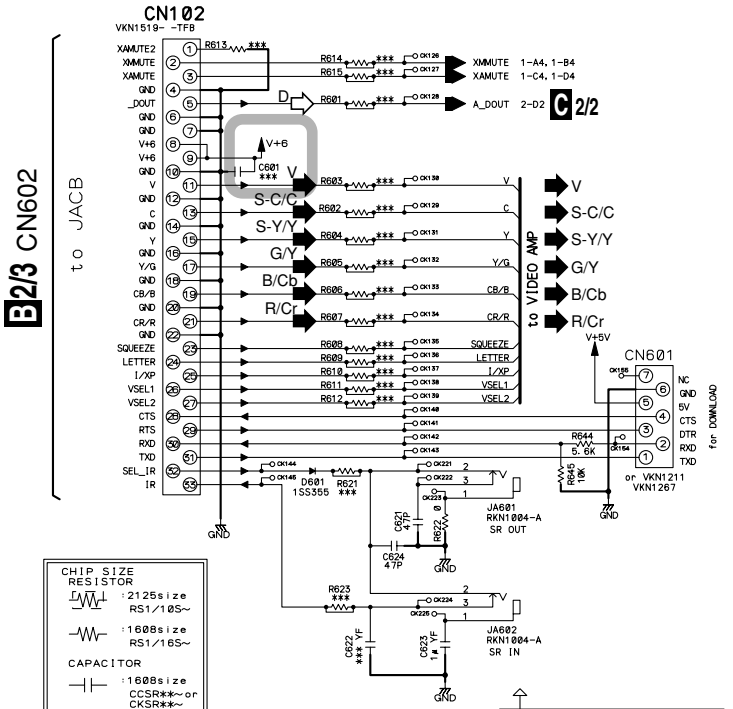
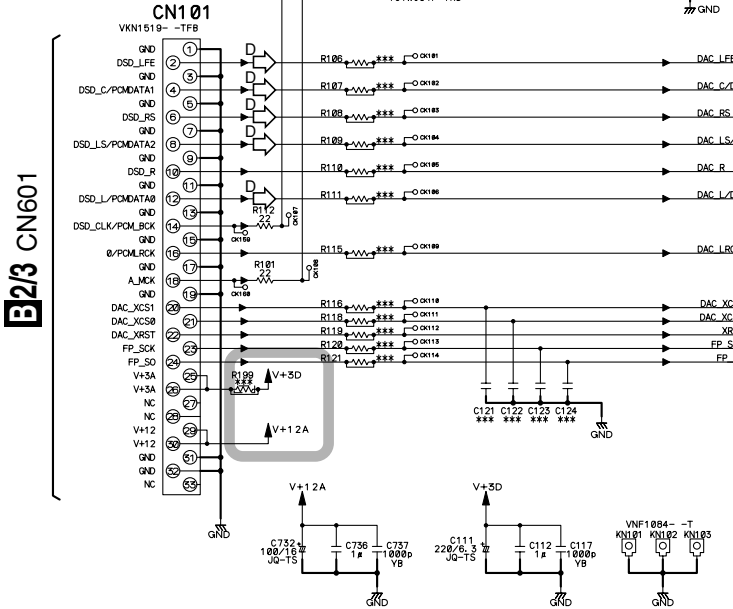

3.6 JCKB ASSY 1/2 [AUDIO BLOCK]

C 1/2 JCKB ASSY (VWV1944)

- V \blacktriangleright : V SIGNAL ROUTE
- S-C/C \blacktriangleright : S-VIDEO OUT C/C SIGNAL ROUTE
- S-Y/Y \blacktriangleright : S-VIDEO OUT Y/Y SIGNAL ROUTE
- R/Cr \blacktriangleright : R/Cr SIGNAL ROUTE
- G/Y \blacktriangleright : G/Y SIGNAL ROUTE
- B/Cb \blacktriangleright : B/Cb SIGNAL ROUTE
- D \blacktriangleright : AUDIO(DIGITAL) SIGNAL ROUTE
- \blacktriangleright : AUDIO SIGNAL ROUTE

 : The power supply is shown with the marked box.



CHIP SIZE RESISTOR	
	: 2125 size
	: RS1/105~
	: 1608 size
	: RS1/165~
CAPACITOR	
	: 1608 size
	: CCSR~ or
	: CKSR~

出力レベル調整を行う場合の出力端子のGNDは接地
 VoH min=4.0 max=5.3 (V)
 VoL min=0 max=0.3 (V)
 GER=E001 (マイコン規格準拠)

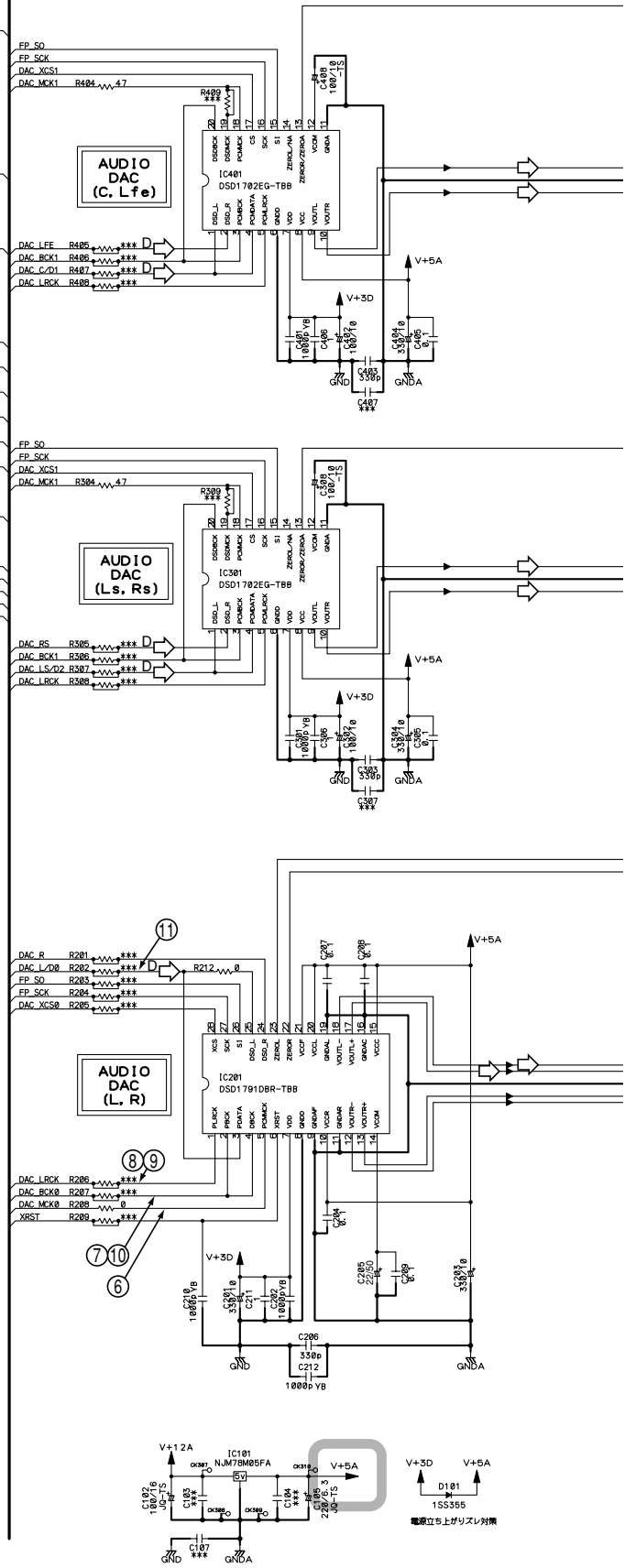

C 1/2

⑥-⑪: Refer to "3.11 WAVEFORMS".

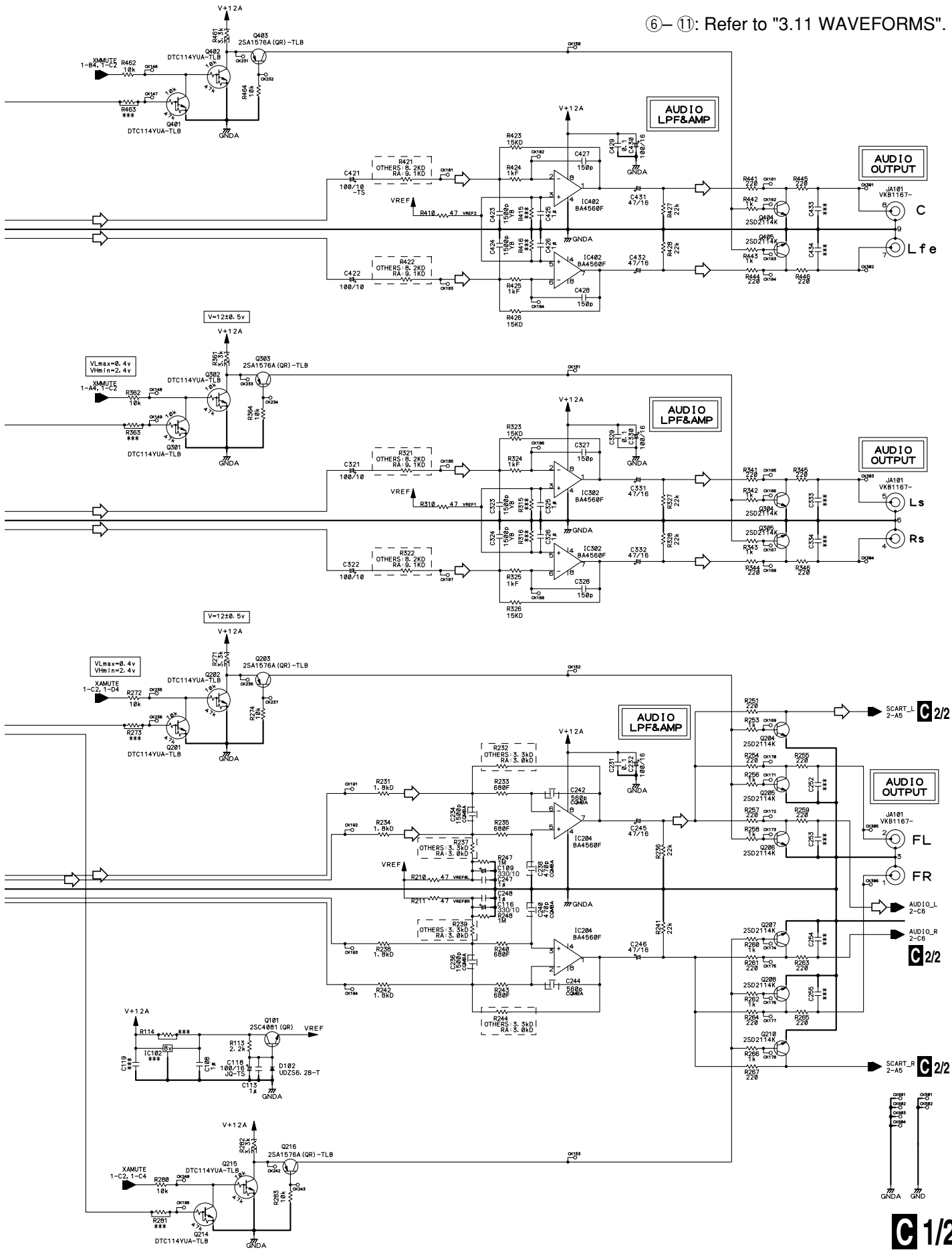

3.7 JCKB ASSY 2/2 [VIDEO BLOCK]

C 2/2 JCKB ASSY (VWV1944)

V → : V SIGNAL ROUTE

S-C/C → : S-VIDEO OUT C/C SIGNAL ROUTE

S-Y/Y → : S-VIDEO OUT Y/Y SIGNAL ROUTE

R/Cr → : R/Cr SIGNAL ROUTE

G/Y → : G/Y SIGNAL ROUTE

B/Cb → : B/Cb SIGNAL ROUTE

D ⇨ : AUDIO(DIGITAL) SIGNAL ROUTE

⇨ : AUDIO SIGNAL ROUTE

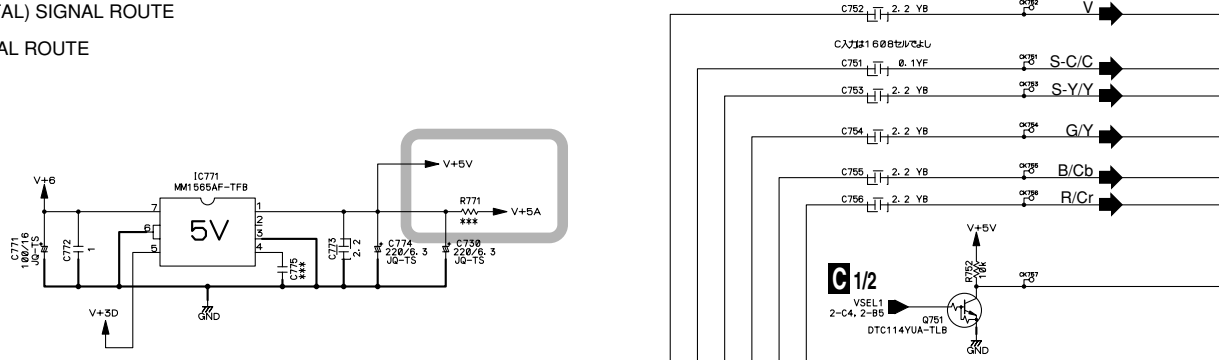

○ : The power supply is shown with the marked box.

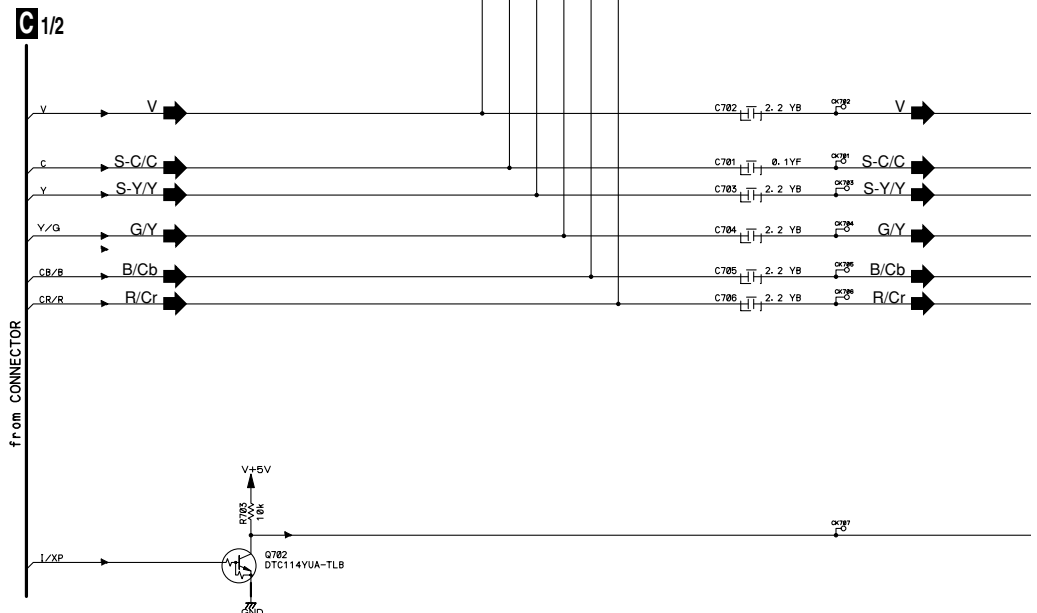

CHIP SIZE RESISTOR	
	: 2125size RS1/10S~
	: 1608size RS1/16S~
CAPACITOR	
	: 2125size CKSQ**~
	: 1608size CCSR**~ or CKSR**~

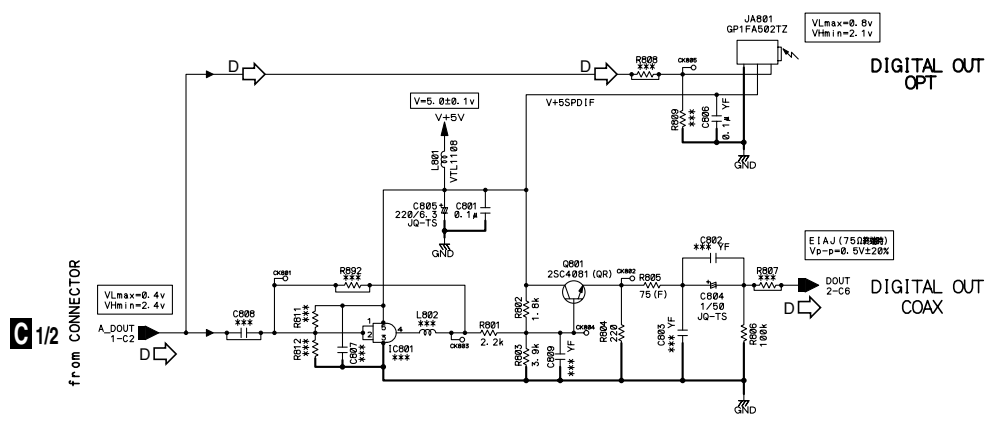

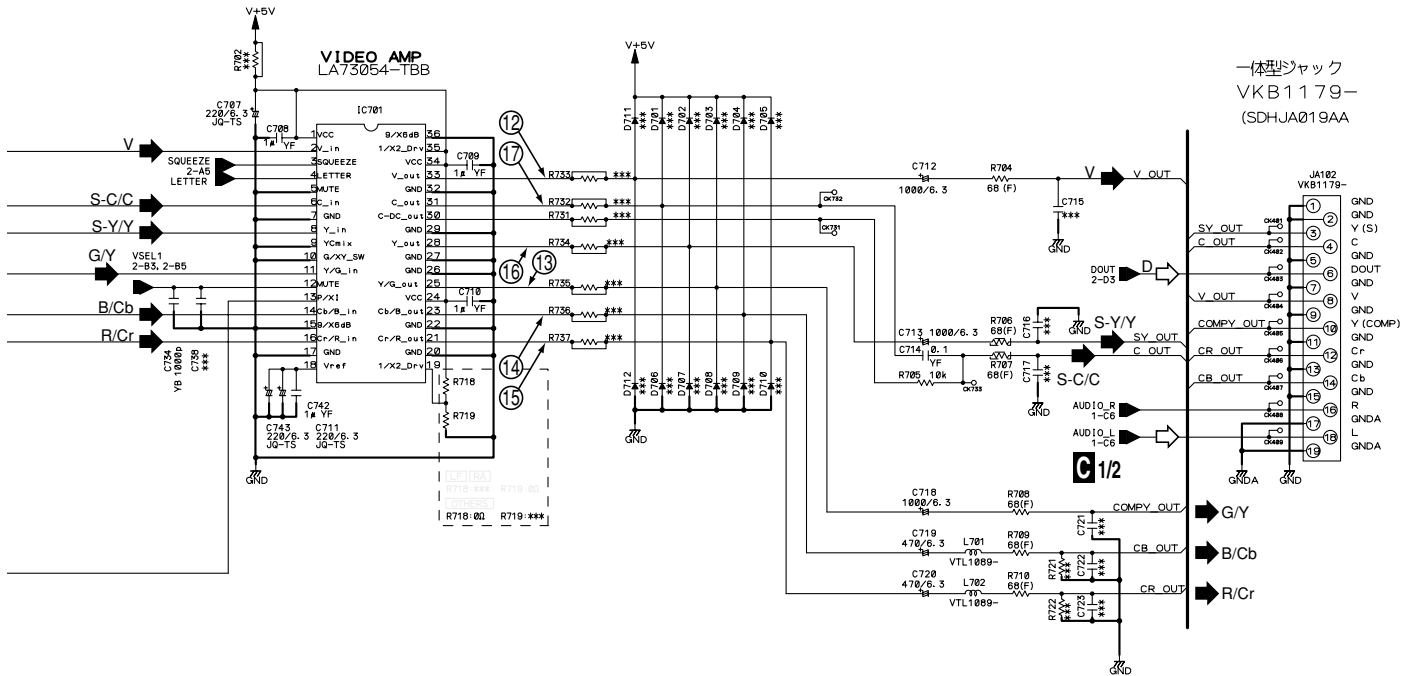
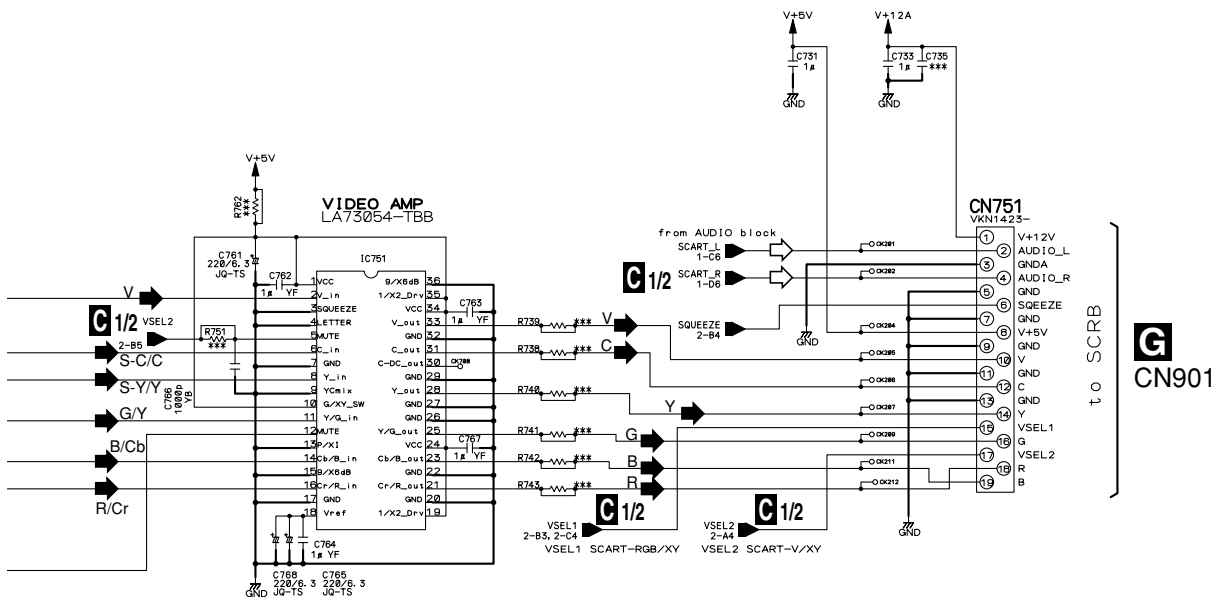

一体型トランス
VKB1179-
(SDHJA019AA)

⑫-⑰: Refer to "3.11 WAVEFORMS".

MODE	V	Y/C	RGB
VSEL1 (BLANK)	L	L	H
VSEL2	H	L	H



3.8 FLKY and PWSB ASSYS

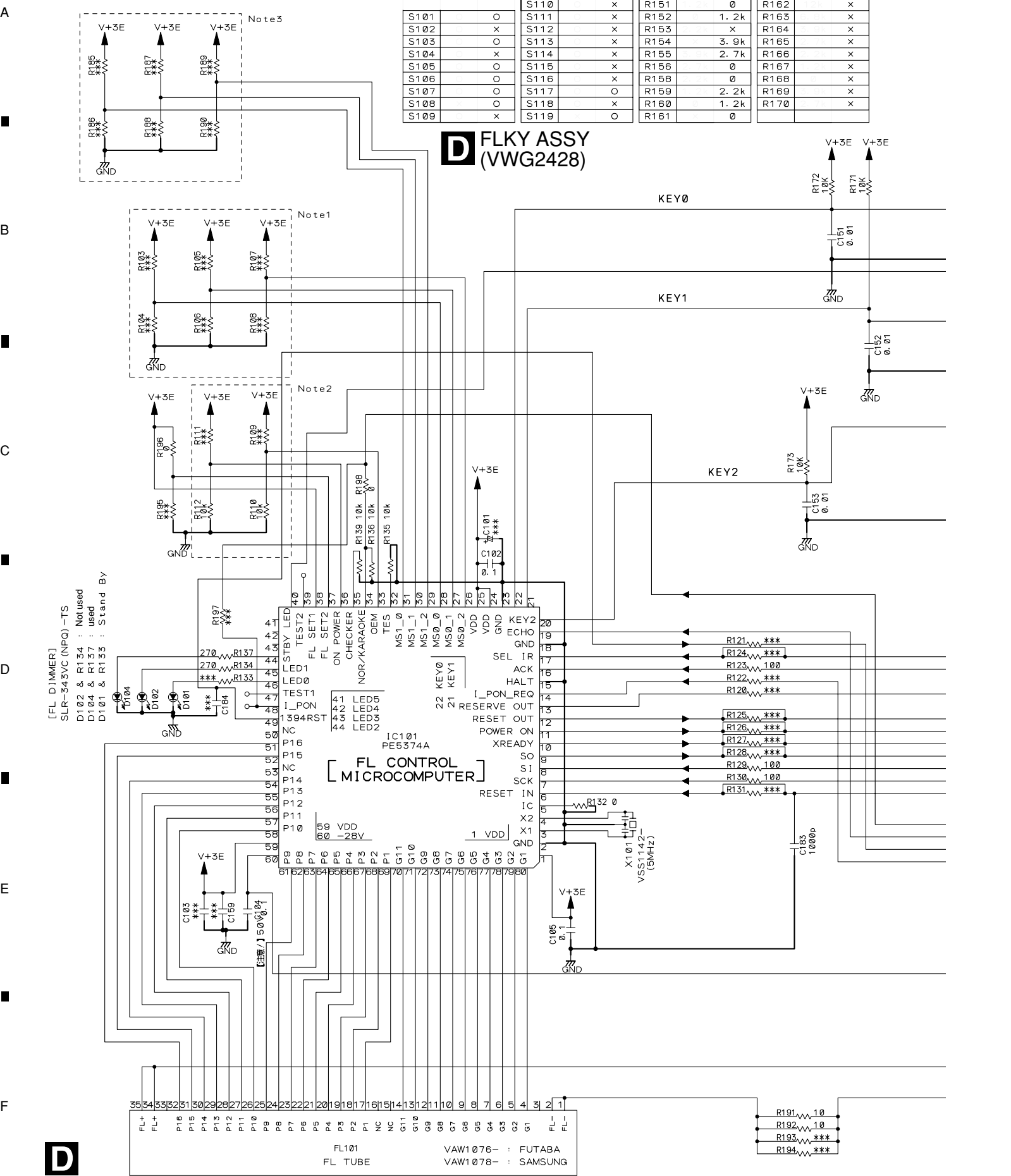

S101	O	S110	X	R151	0	R162	X
S102	X	S111	X	R152	1.2k	R163	X
S103	O	S112	X	R153	X	R164	X
S104	X	S113	X	R154	3.9k	R165	X
S105	O	S114	X	R155	2.7k	R166	X
S106	O	S115	X	R156	0	R167	X
S107	O	S116	X	R158	0	R168	X
S108	O	S117	O	R159	2.2k	R169	X
S109	X	S118	X	R160	1.2k	R170	X
		S119	O	R161	0		

D FLKY ASSY (VWG2428)

[FL DIMMER]
 SLR-343VC (NFQ) -TS
 D102 & R134 : Not used
 D104 & R137 : used
 D101 & R133 : Stand By

[FL CONTROL MICROCOMPUTER]

IC101 PE5374A

D

Note1, Note2, Note3

10k

R185	x
R187	x
R189	o
R186	o
R188	o
R190	x

R103	x
R105	x
R107	x
R104	o
R106	o
R108	o
R109	x
R110	o
R111	x
R112	o

: The power supply is shown with the marked box.

Normal / Karaoke	
R184	x
R199	o

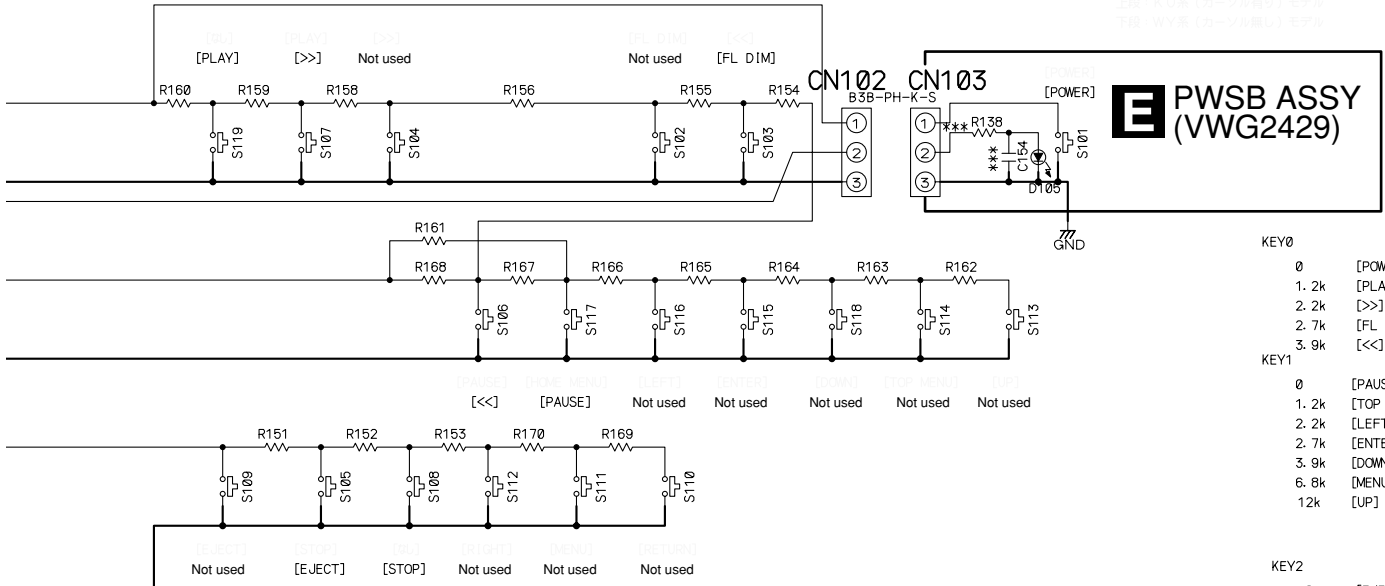

PWSB ASSY (VWG2429)

- KEY0
- 0 [POWER]
 - 1. 2k [PLAY]
 - 2. 2k [>>]
 - 2. 7k [FL DIM]
 - 3. 9k [<<]
- KEY1
- 0 [PAUSE]
 - 1. 2k [TOP MENU]
 - 2. 2k [LEFT]
 - 2. 7k [ENTER]
 - 3. 9k [DOWN]
 - 6. 8k [MENU]
 - 12k [UP]

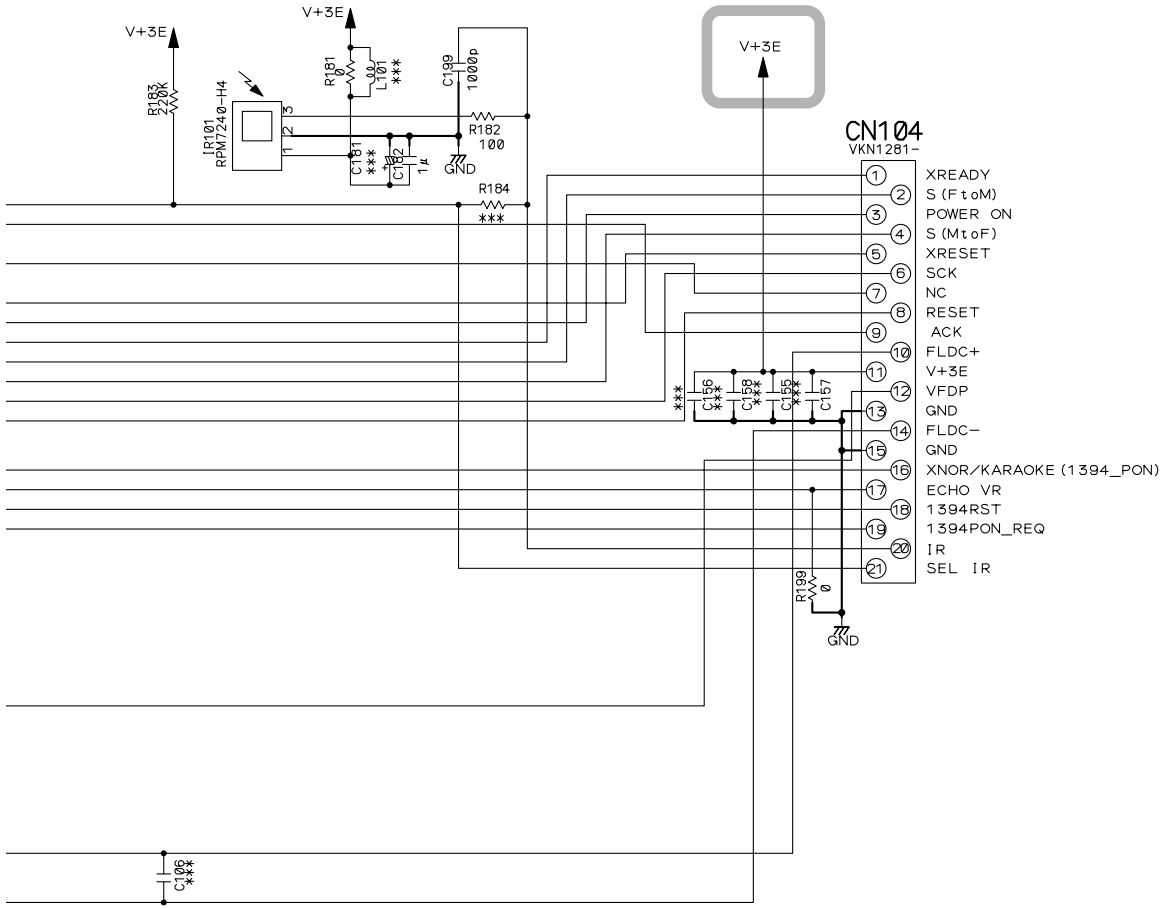

B3/3
CN105

- FLKY ASSY**
- S105 : OPEN/CLOSE ▲
 - S106 : ◀▶
 - S107 : ▶▶▶▶
 - S108 : ■
 - S117 : ▯
 - S119 : ▼
- PWSB ASSY**
- S101 : ◯ STANDBY ON

3.9 SCRIB ASSY

SCRIB ASSY (VWV1939)

- V → : V SIGNAL ROUTE
- C → : C SIGNAL ROUTE
- Y → : Y SIGNAL ROUTE
- R → : R SIGNAL ROUTE
- G → : G SIGNAL ROUTE
- B → : B SIGNAL ROUTE
- ↪ : AUDIO SIGNAL ROUTE

MODE	V	Y/C	RGB
VSEL1 (BLANK)	L	L	H
VSEL2	H	L	H

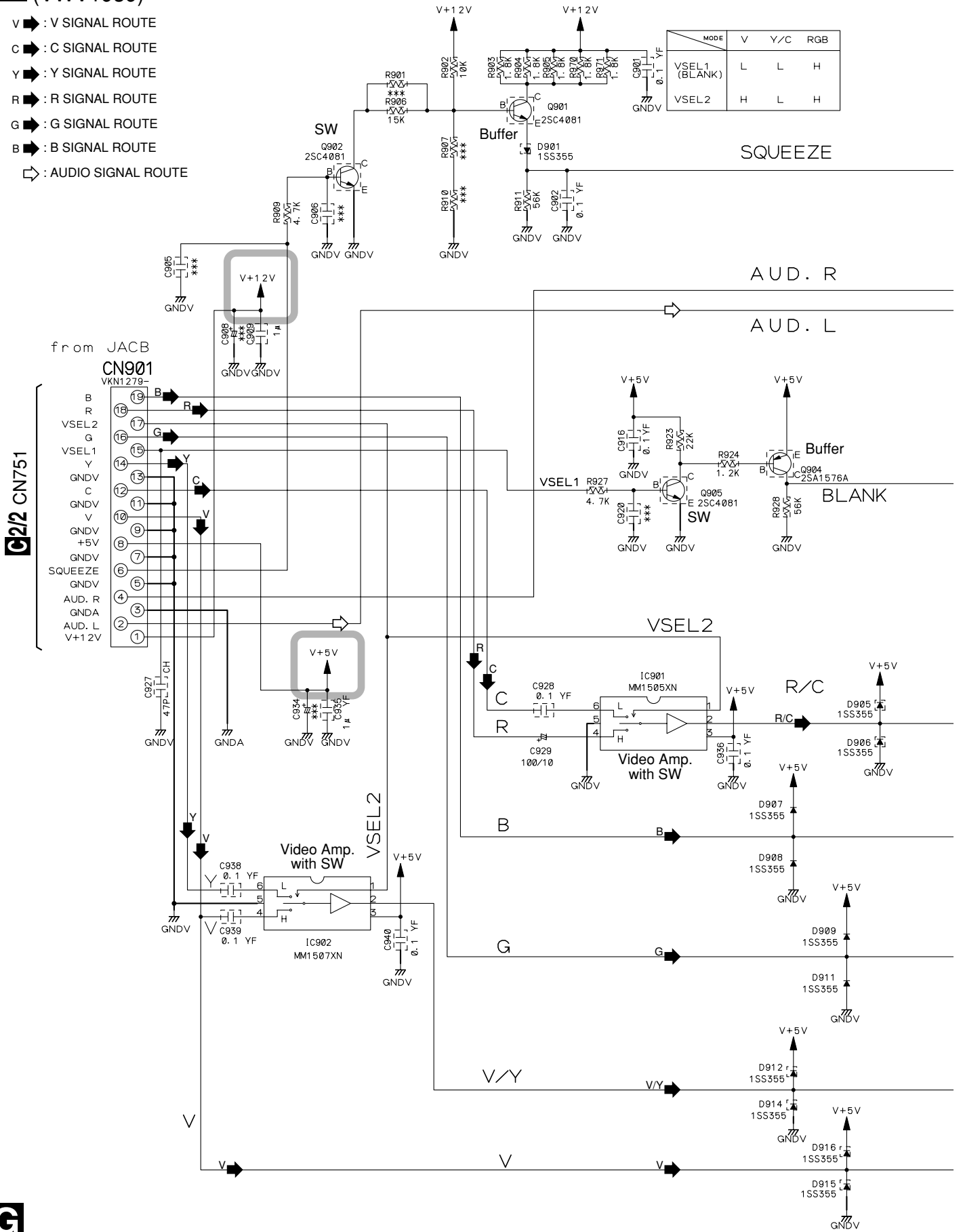

 : The power supply is shown with the marked box.

RY901-RY905: Relay SW

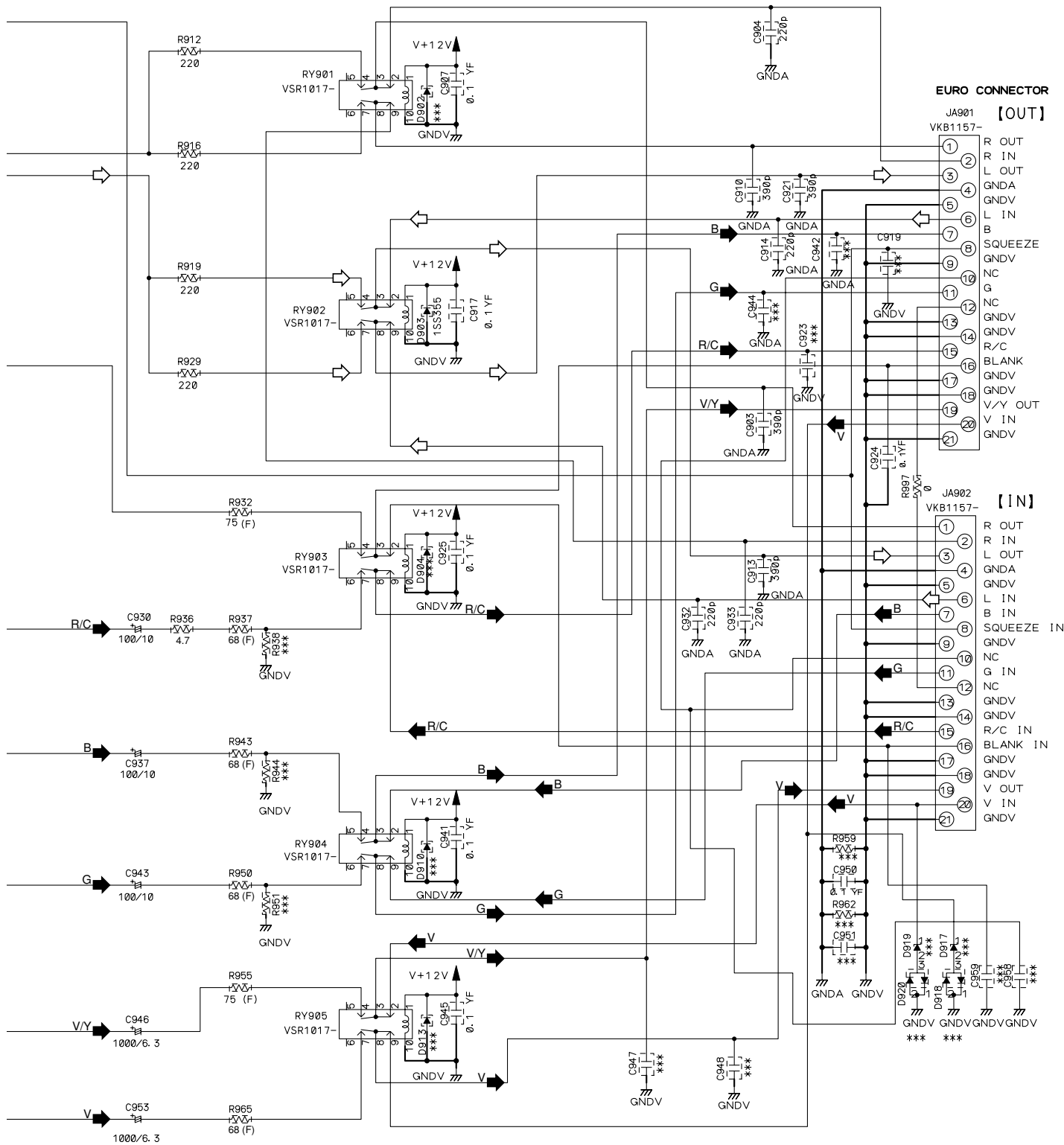

***:parts not mounted





F POWER SUPPLY UNIT (VWR1366)

« NOTE OF SPARE PARTS IN POWER SUPPLY (SYPS) UNIT »

- In case of repairing, use the described parts only to prevent an accident.
- Please write the red ✓ mark on the board when the primary section of POWER SUPPLY (SYPS) Unit is repaired.
- Please take care to keep the space, not touching other parts when replacing the parts.

CAUTION : FOR CONTINUED PROTECTION AGAINST RISK OF FIRE, REPLACE ONLY WITH SAME TYPE NO. 491.800 MFD, BY LITTELFUSE INC. FOR P301 (AEK7063).

CAUTION : FOR CONTINUED PROTECTION AGAINST RISK OF FIRE, REPLACE ONLY WITH SAME TYPE NO. 49101.6 MFD, BY LITTELFUSE INC. FOR P101 (AEK7066).

3.10 POWER SUPPLY UNIT

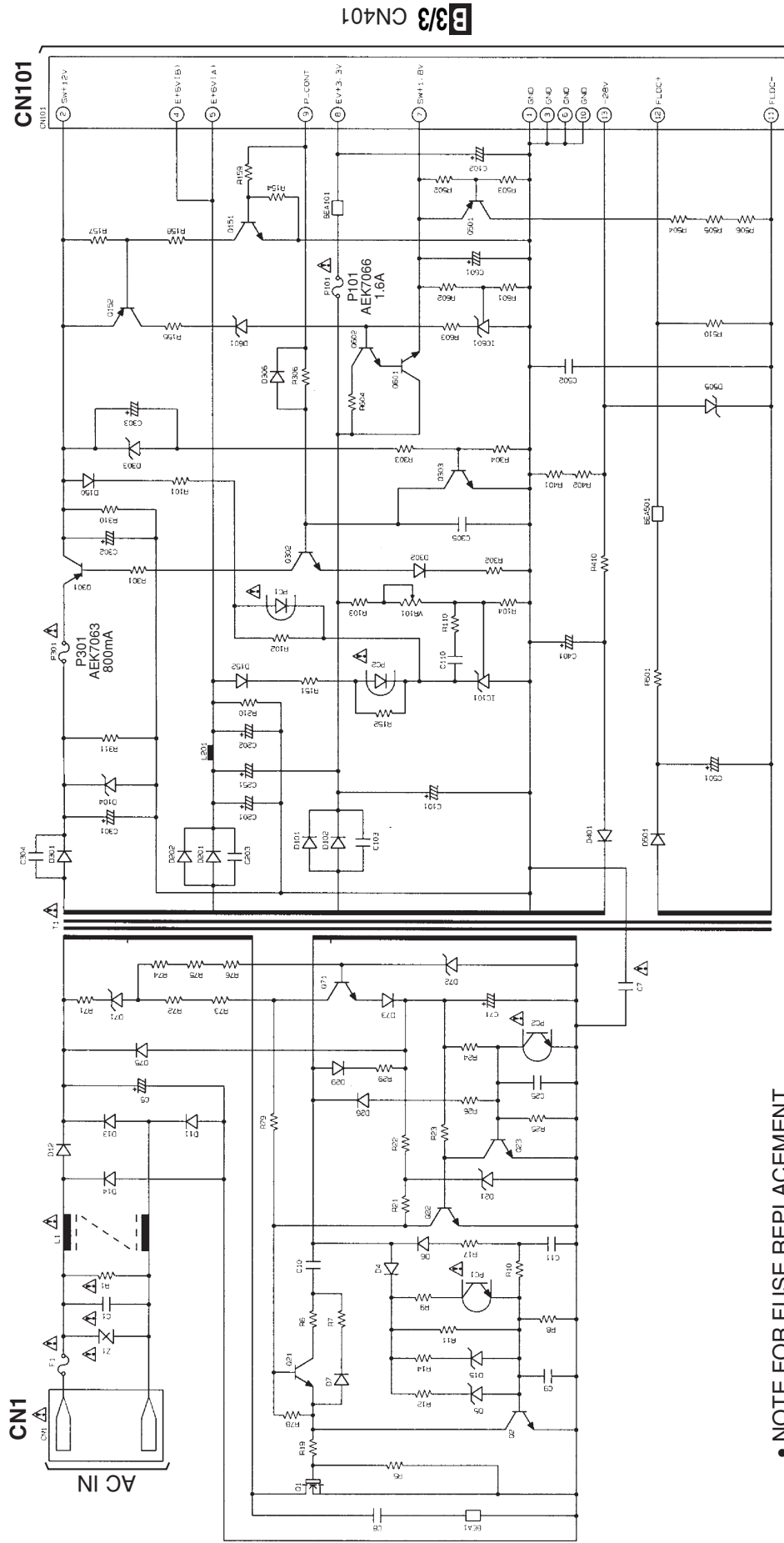

• NOTE FOR FUSE REPLACEMENT
CAUTION -FOR CONTINUED PROTECTION AGAINST RISK OF FIRE, REPLACE WITH SAME TYPE AND RATINGS ONLY.



3.11 WAVEFORMS

Note : The encircled numbers denote measuring point in the schematic diagram.

Measurement condition : No. 1 to 2 and 12 to 17 : reference A1 (DVD), T2-chp 19, Color-bar
No. 6 to 11 : reference A1 (DVD), T2-chp 1

B DVDM ASSY

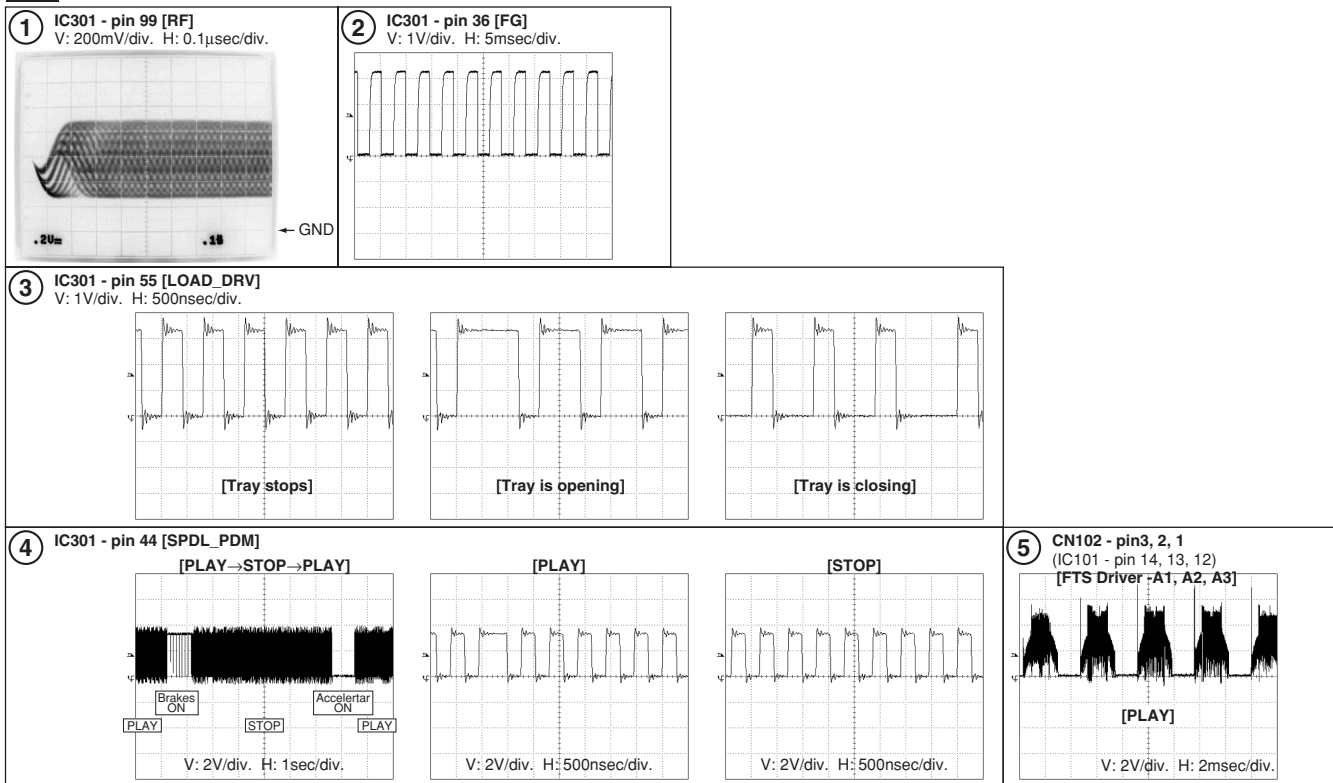

C JCKB ASSY

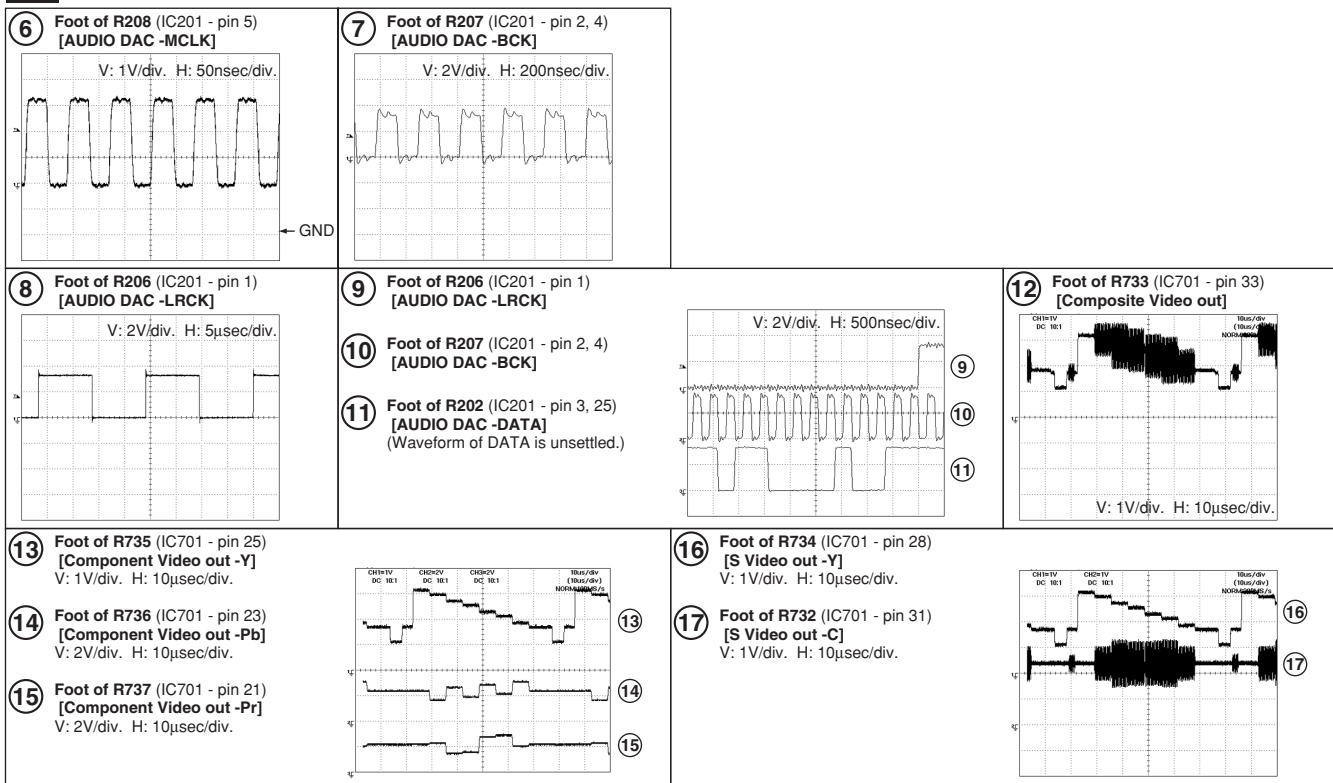

1

2

3

4

A

B

C

D

E

F

1

2

3

4

4. PCB CONNECTION DIAGRAM

4.1 LOAB ASSY

NOTE FOR PCB DIAGRAMS :

1. Part numbers in PCB diagrams match those in the schematic diagrams.
2. A comparison between the main parts of PCB and schematic diagrams is shown below.

Symbol In PCB Diagrams	Symbol In Schematic Diagrams	Part Name
		Transistor
		Transistor with resistor
		Field effect transistor
		Resistor array
		3-terminal regulator

3. The parts mounted on this PCB include all necessary parts for several destinations.
For further information for respective destinations, be sure to check with the schematic diagram.
4. View point of PCB diagrams.

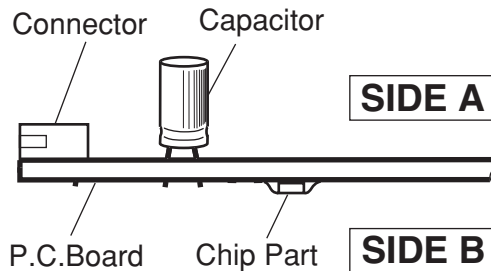

SIDE A

SIDE B

A LOAB ASSY (VNP1910-A)

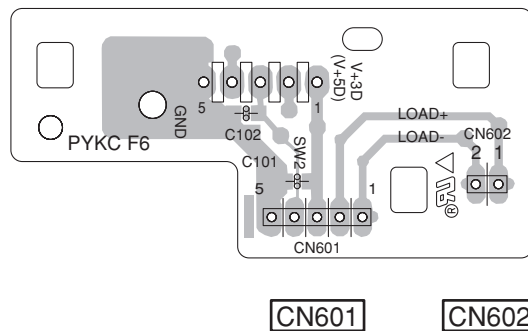
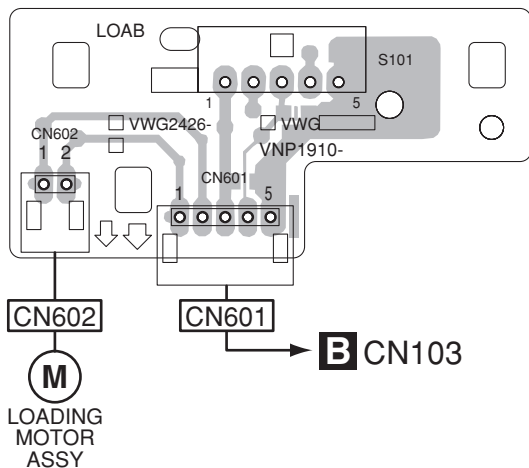

4.2 DVDM ASSY

SIDE A

SIDE A

B DVDM ASSY (VNP1921-A)

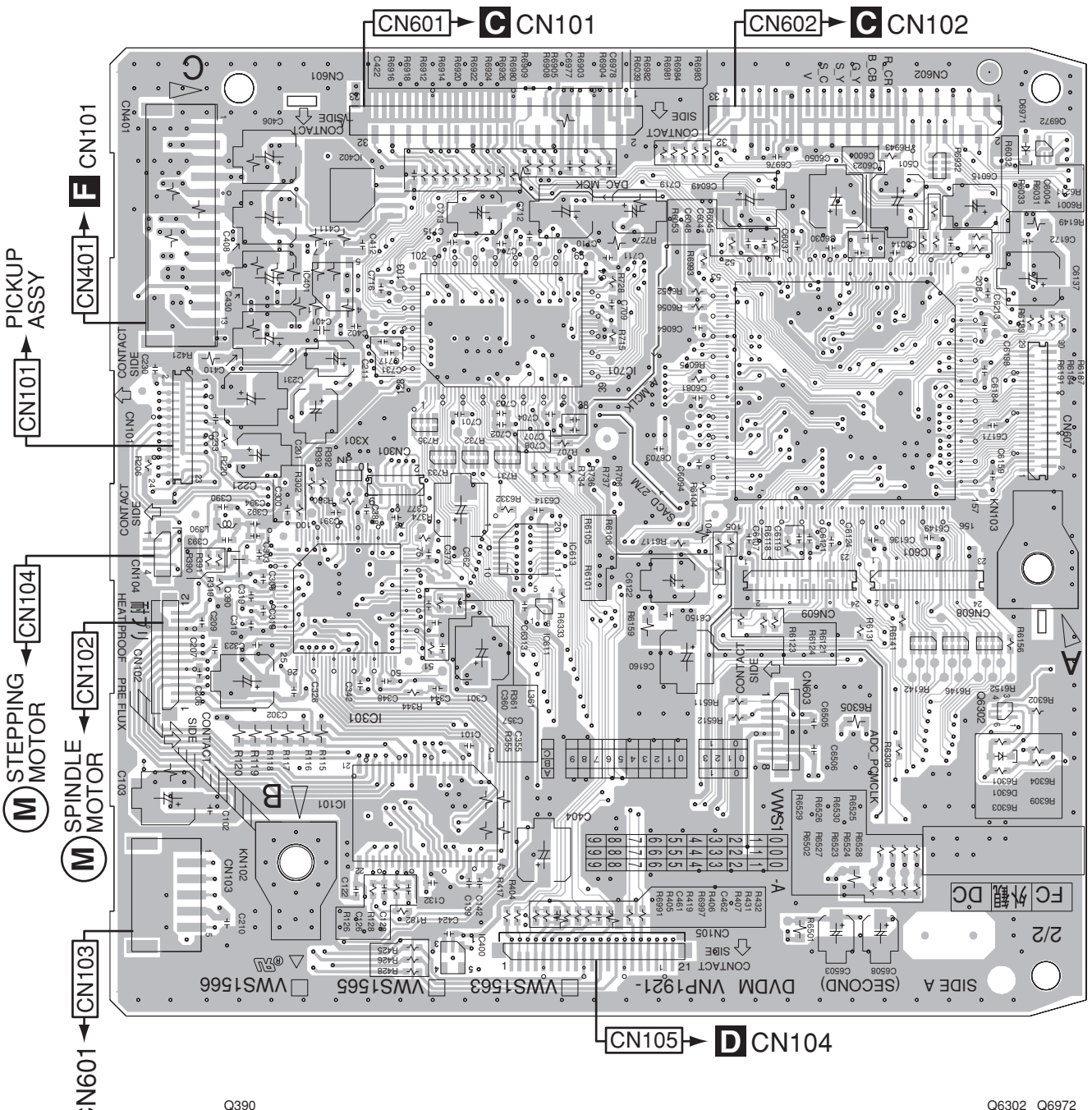

Q390 Q6302 Q6972

IC402	IC701	IC601
IC401	IC613	
IC301	IC101	IC611
	IC400	

B

B

SIDE B

SIDE B

B DVDM ASSY (VNP1921-A)

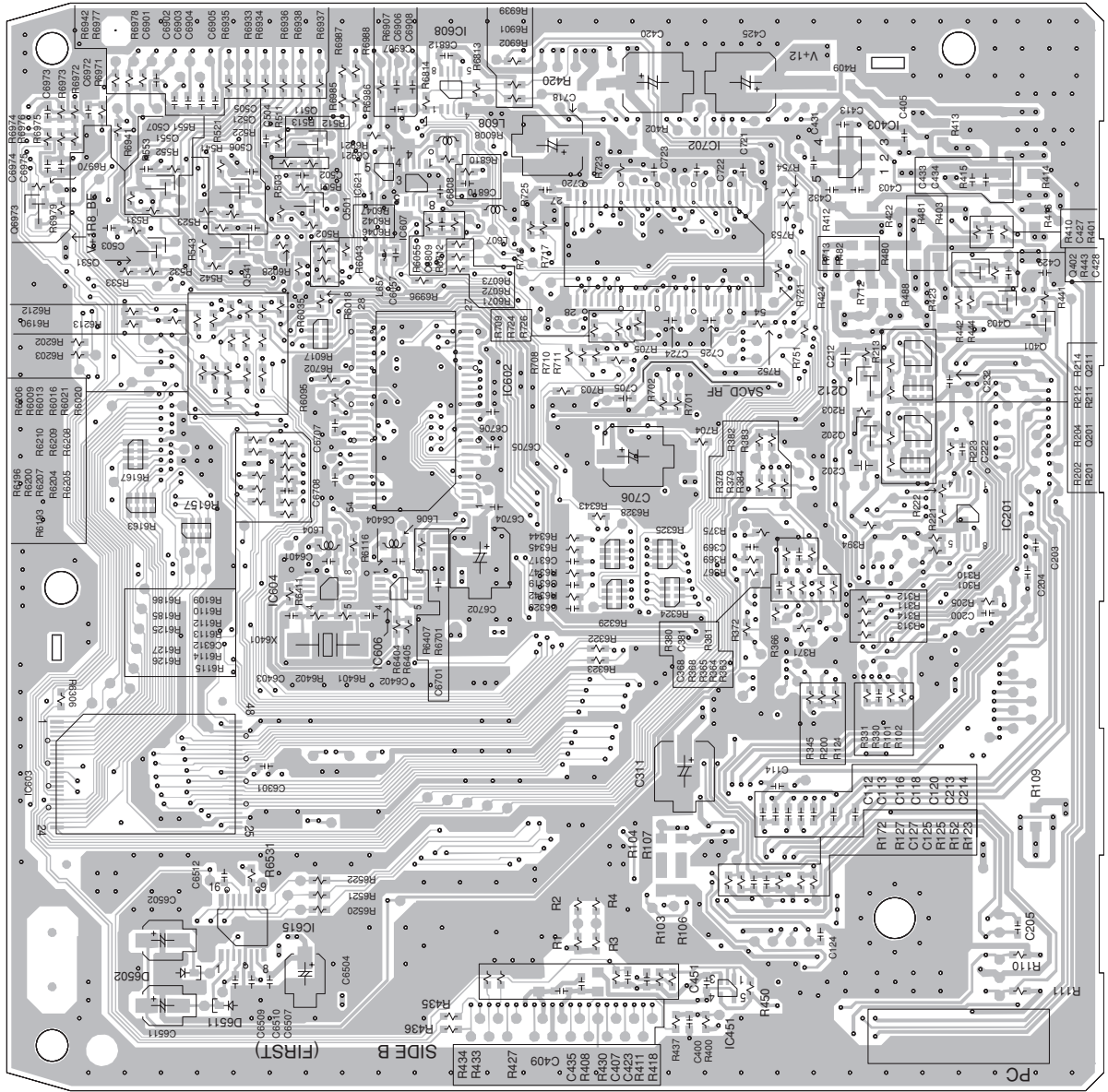

Q6973	Q551	Q521	Q511	Q212	Q211	Q402
	Q531	Q541	Q501	Q202	Q201	Q403
						Q401
IC603	IC615	IC621	IC608	IC702	IC403	IC201
			IC607			
			IC602			
		IC604	IC606	IC451		

B

B

4.3 JCKB ASSY

SIDE B

A

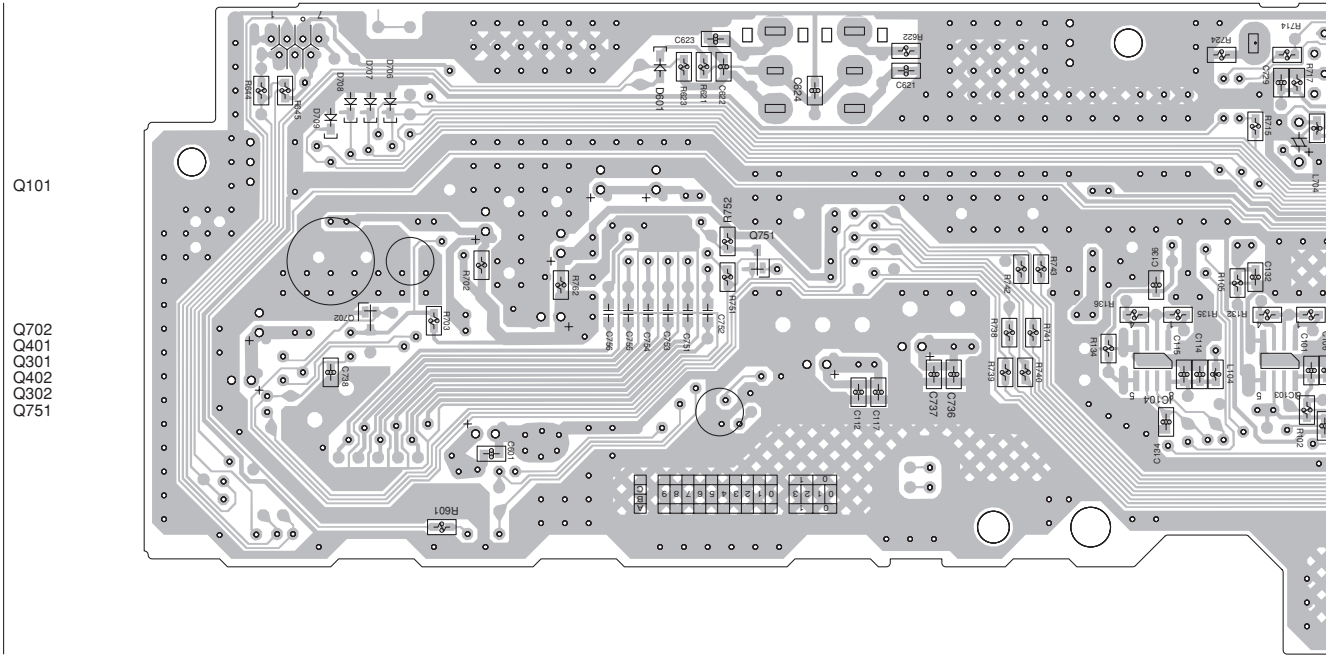

B

C

C JCKB ASSY (VNP1919-B)

SIDE A

D

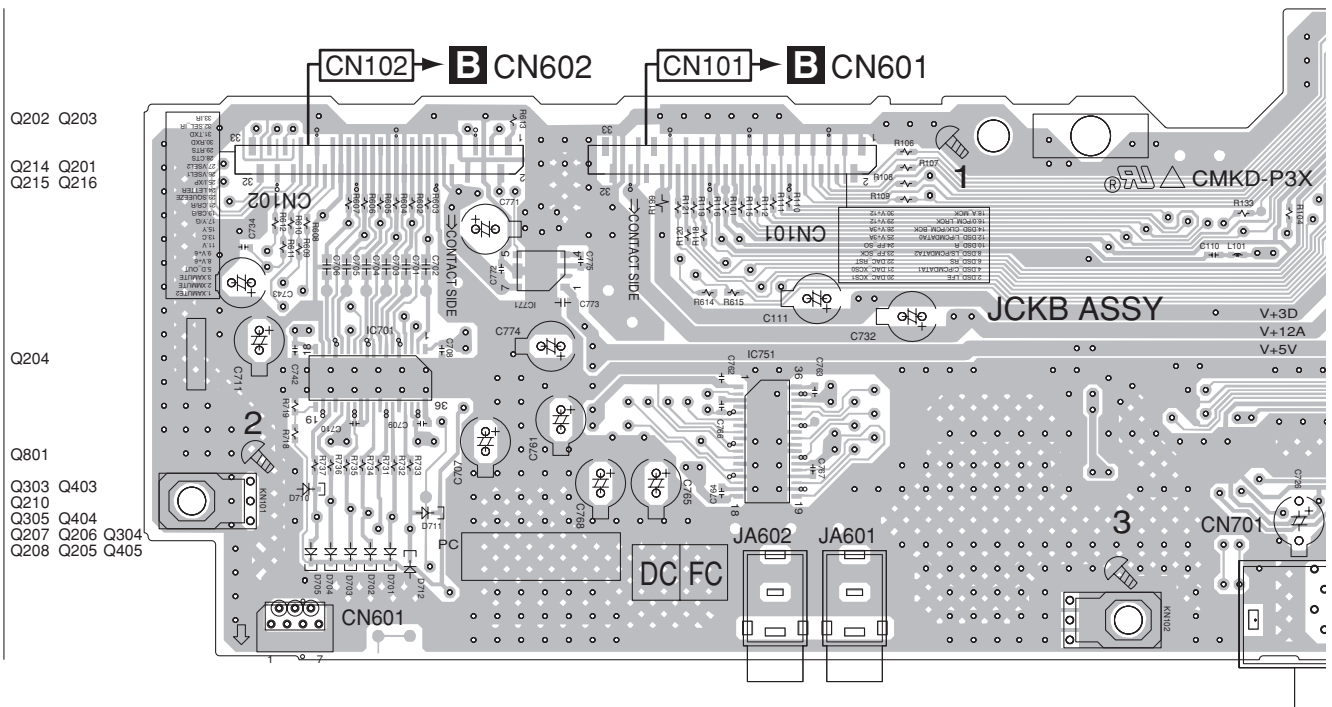

E

F



SIDE B

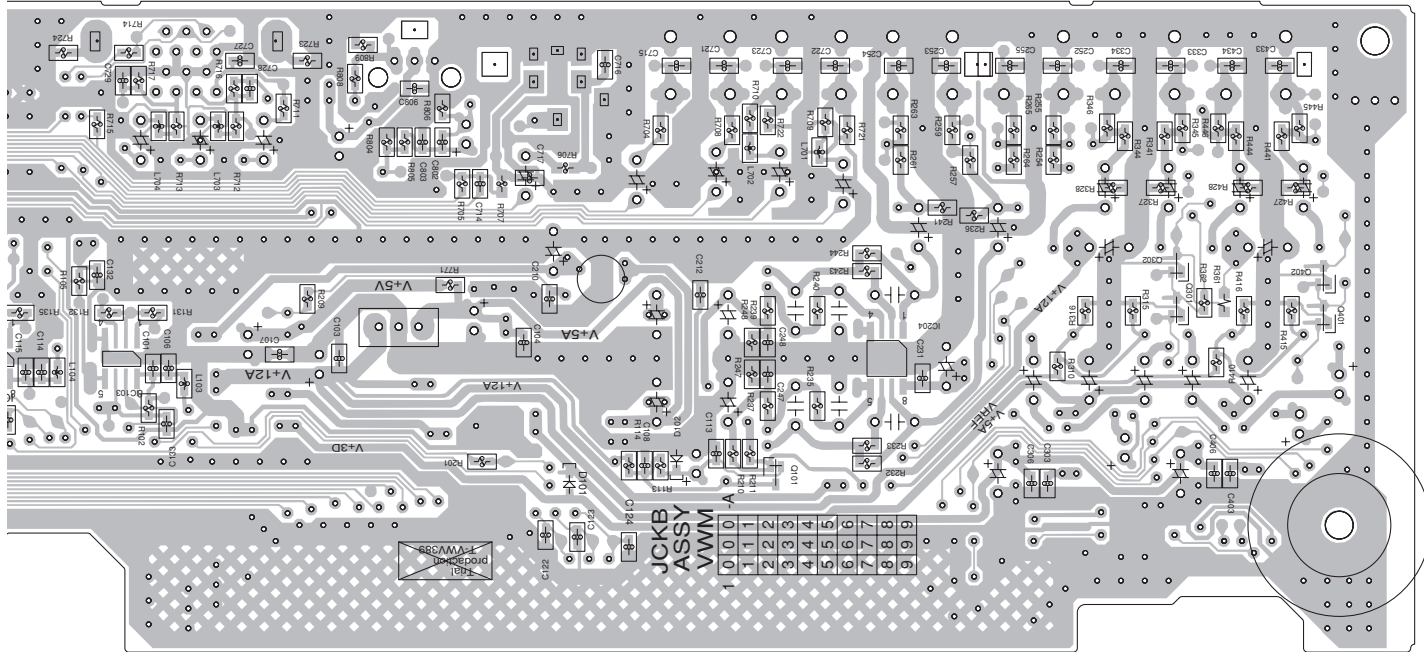

A

B

C

SIDE A

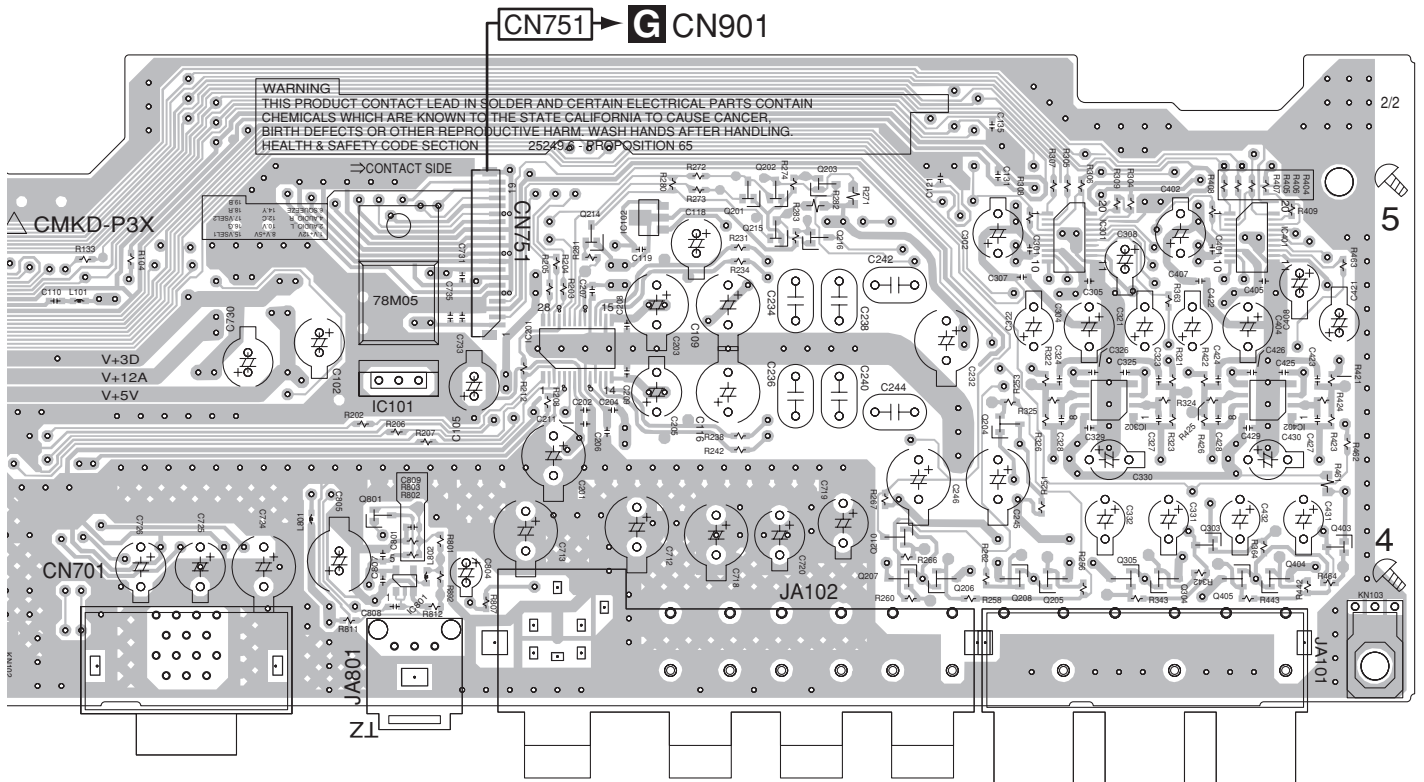

D

E

F

C

4.4 FLKY and PWSB ASSYS

SIDE A

A

D FLKY ASSY
(VNP1901-B)

B

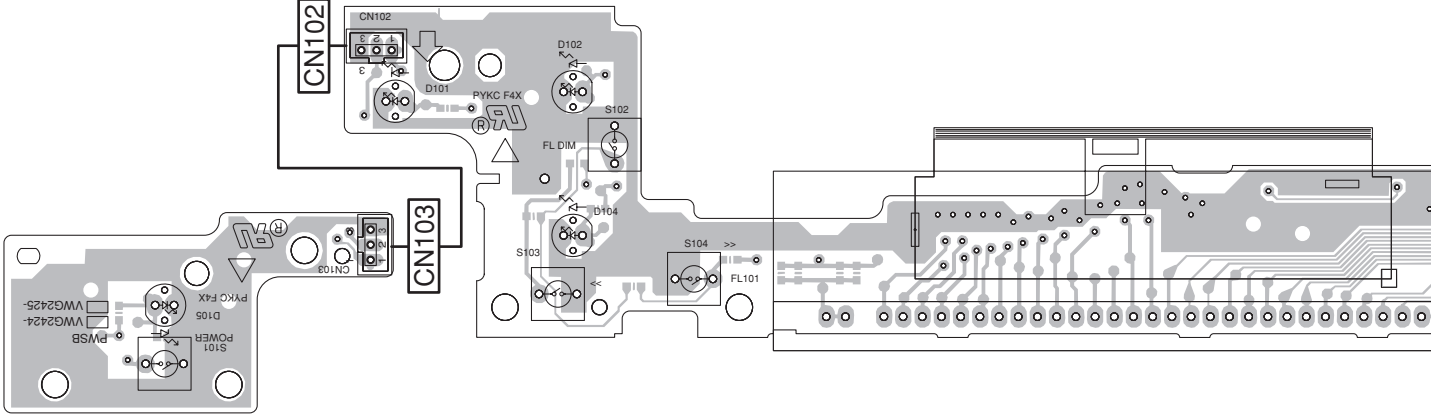

E PWSB ASSY
(VNP1901-B)

C

SIDE B

D

E PWSB ASSY
(VNP1901-B)

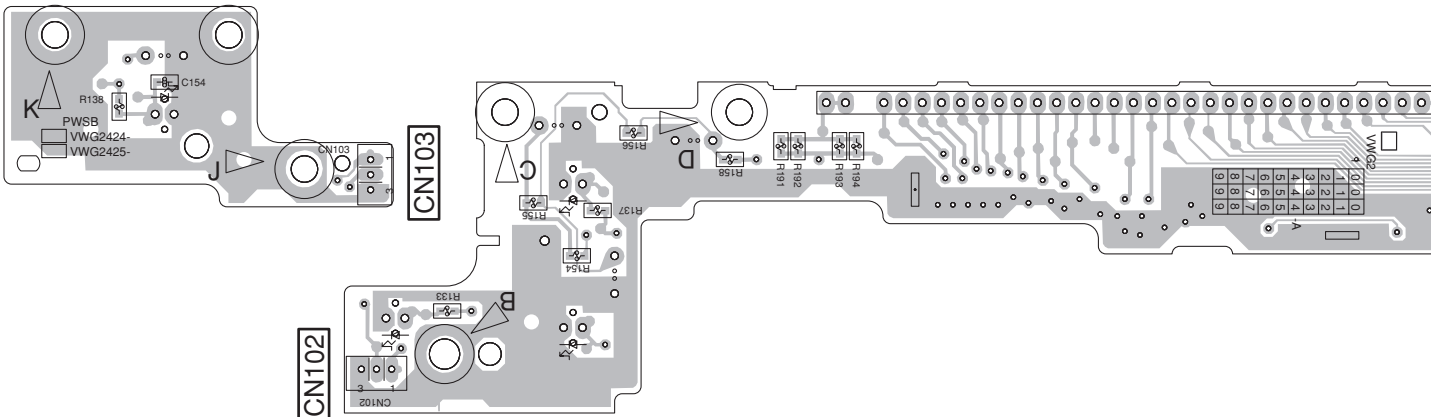

D FLKY ASSY
(VNP1901-B)

E

F

D E

SIDE A

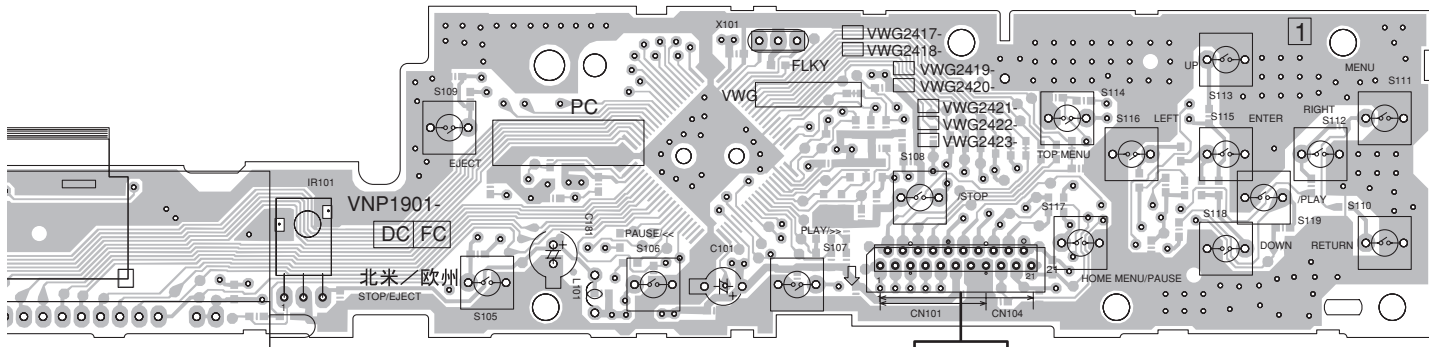

CN104 → **B** CN105

SIDE B

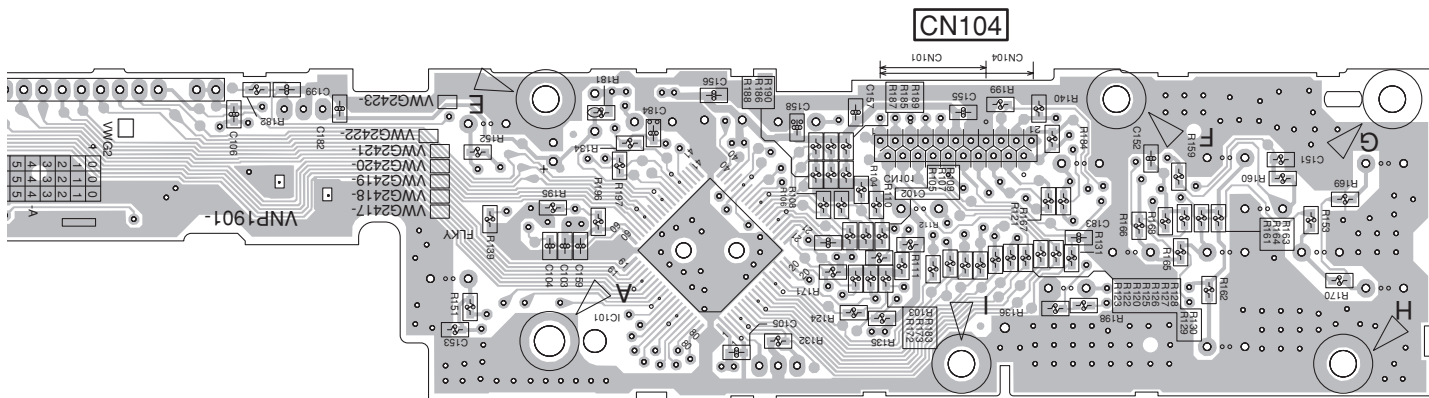

CN104

4.5 POWER SUPPLY UNIT

SIDE A

SIDE B

F POWER SUPPLY UNIT [VWR1366]

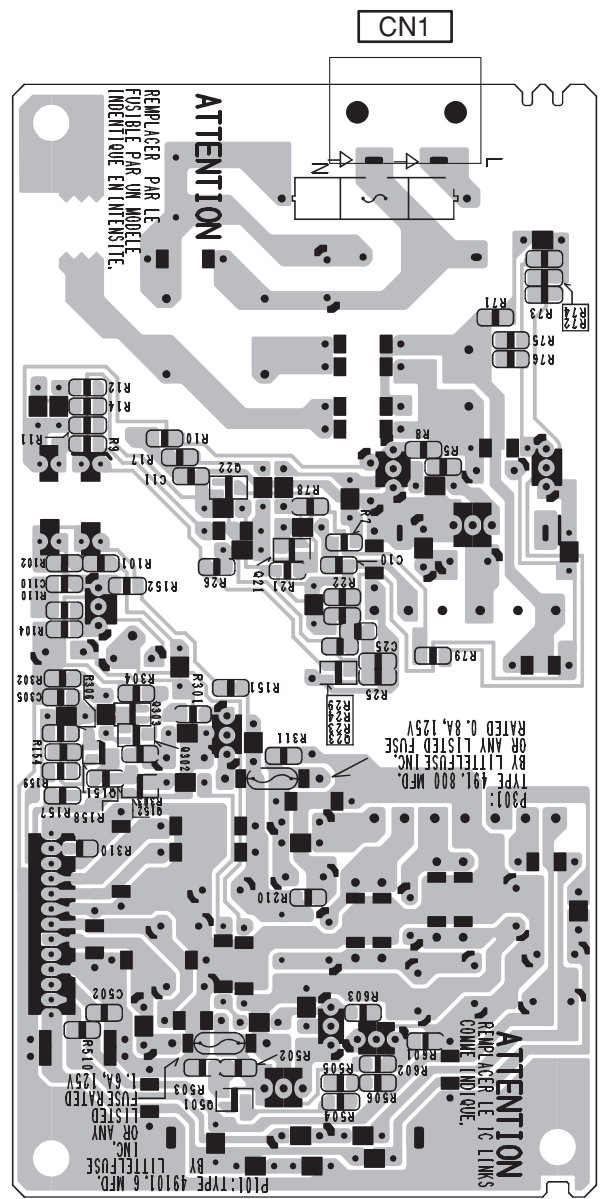
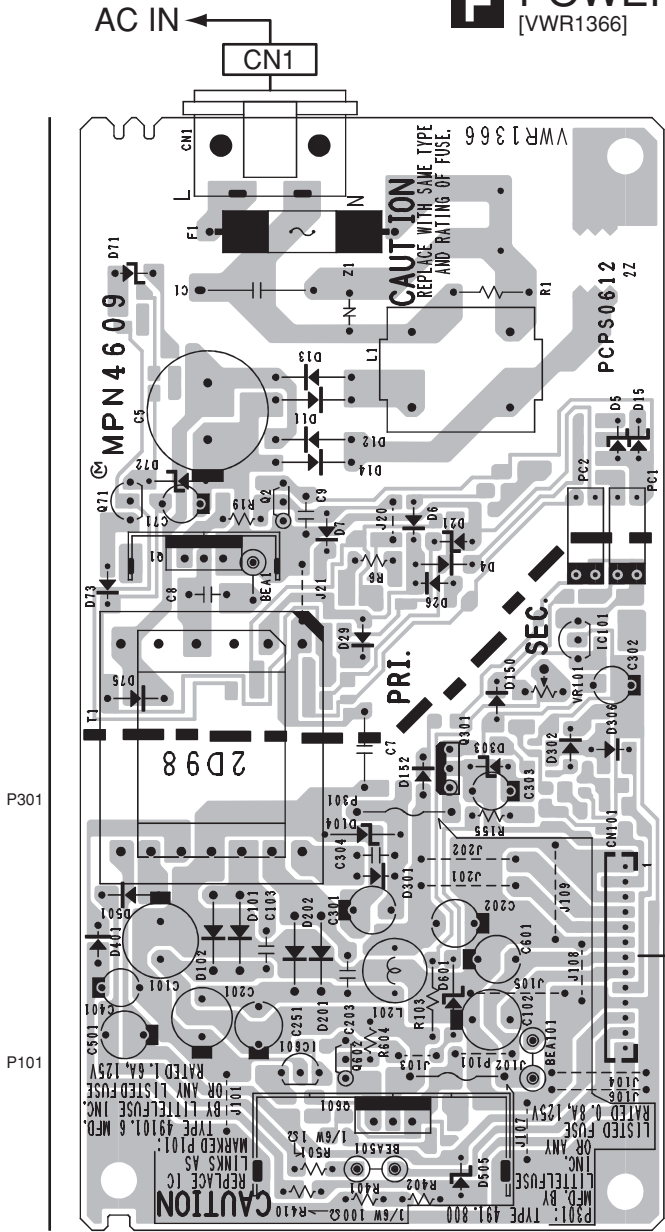

P301

P101



4.6 SCRIB ASSY

SIDE B

SIDE B

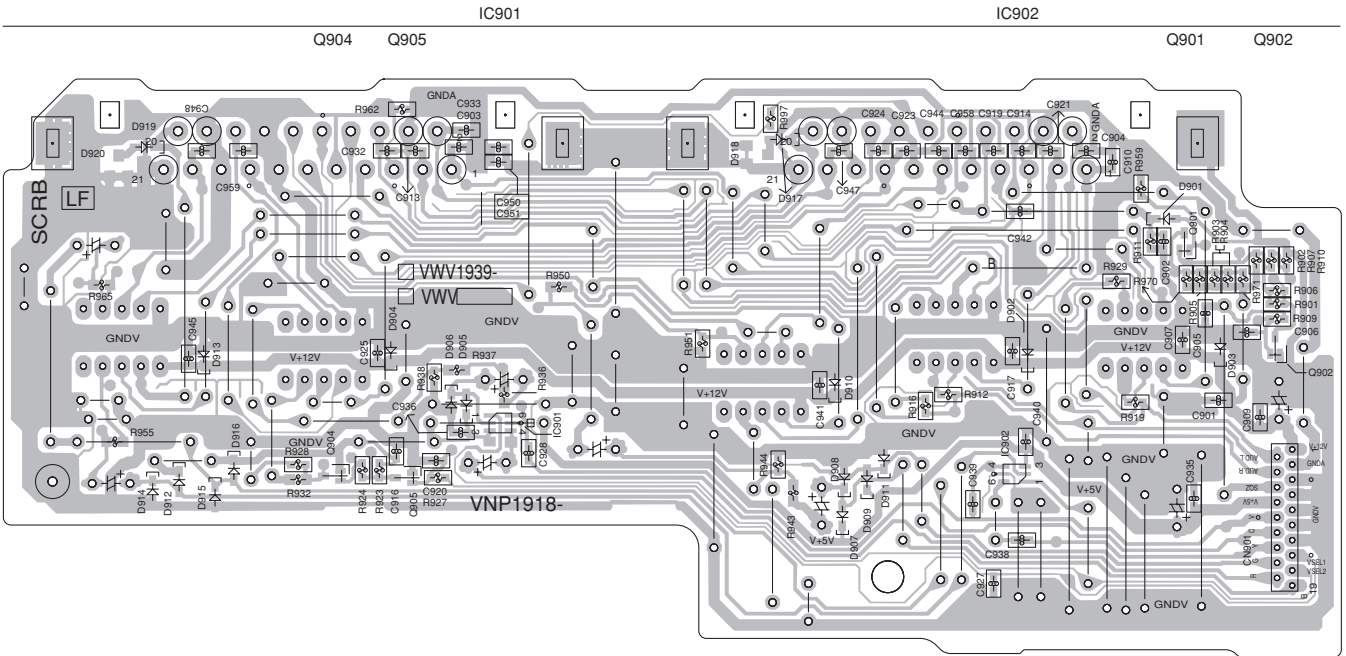

CN901

G SCRIB ASSY (VNP1918-A)

SIDE A

SIDE A

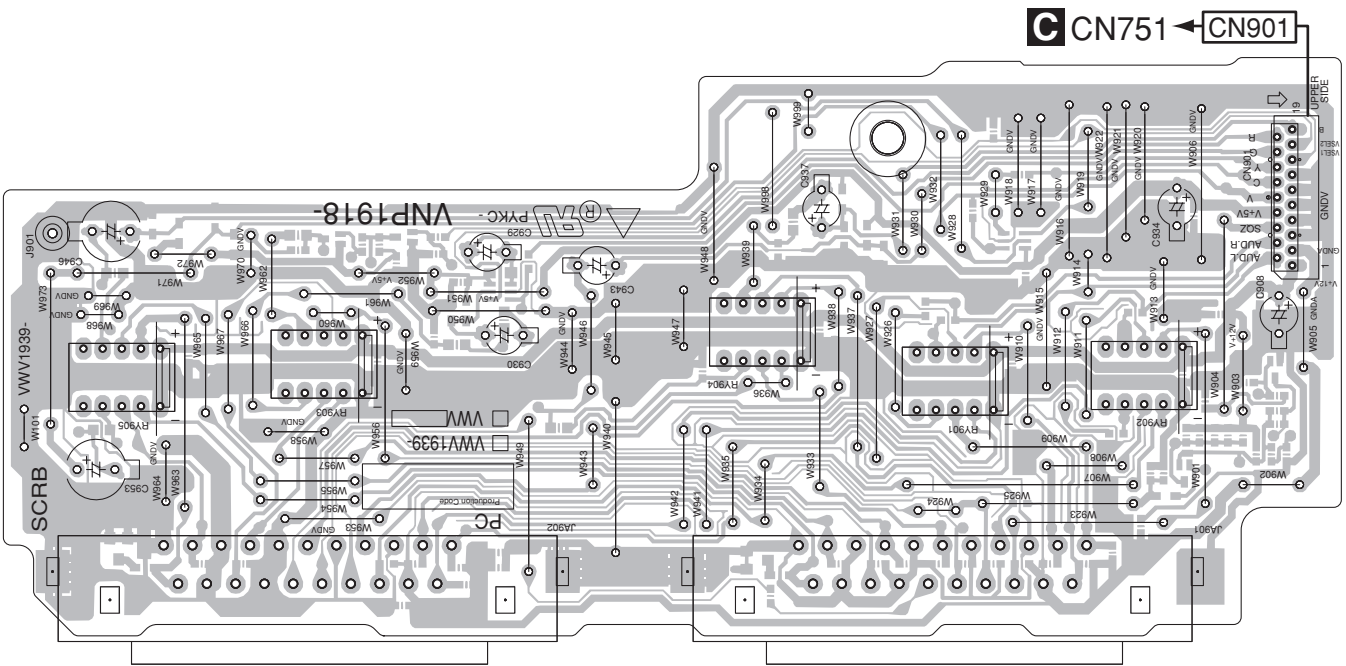

5. PCB PARTS LIST

NOTES: ● Parts marked by "NSP" are generally unavailable because they are not in our Master Spare Parts List.

● The Δ mark found on some component parts indicates the importance of the safety factor of the part. Therefore, when replacing, be sure to use parts of identical designation.

● When ordering resistors, first convert resistance values into code form as shown in the following examples.

Ex.1 When there are 2 effective digits (any digit apart from 0), such as 560 ohm and 47k ohm (tolerance is shown by J=5%, and K=10%).

560 Ω \rightarrow 56 x 10¹ \rightarrow 561 RD1/4PU $\overline{561} J$

47k Ω \rightarrow 47 x 10³ \rightarrow 473 RD1/4PU $\overline{473} J$

0.5 Ω \rightarrow R50 RN2H $\overline{R50} K$

1 Ω \rightarrow 1R0 RS1P $\overline{1R0} K$

Ex.2 When there are 3 effective digits (such as in high precision metal film resistors).

5.62k Ω \rightarrow 562 x 10¹ \rightarrow 5621 RN1/4PC $\overline{5621} F$

Mark No. Description Part No.

LIST OF ASSEMBLIES

NSP	1..LOADING MECHA. ASSY	VWT1207
NSP	2..LOAB ASSY	VWG2426
	1..DVDM ASSY	VWS1563
	1..JCKB ASSY	VWV1944
NSP	1..FLKB ASSY	VWM2186
	2..FLKY ASSY	VWG2428
NSP	2..PWSB ASSY	VWG2429
Δ	1..POWER SUPPLY UNIT	VWR1366
	1..SCRB ASSY	VWV1939

Mark No. Description Part No.

Δ LOAB ASSY [VWG2426]

SWITCHES AND RELAYS

S101	REAF SWITCH	VSK1011
------	-------------	---------

OTHERS

CN602	CONNCTOR	S2B-PH-K
CN601	CONNCTOR	S5B-PH-K
	PRINTED CIRCUIT BOARD	VNP1910

Δ DVDM ASSY [VWS1563]

SEMICONDUCTORS

IC602	K4S281632D-TC75
IC702	K4S641632F-TC75
IC101	M63018FP
Δ IC401	MM1565AF
Δ IC402	PQ033EZ01ZP
Δ IC403	PQ1L333M2SP
IC400	PST3228
IC701	SAA7893HL/C2
IC601	STI5588CVB
IC301	STM6316ATXXA
IC608	TC7WH34FU
IC604, IC606, IC607	TC7WU04FU
IC603	VYW2087
Q390, Q501, Q511, Q521, Q531	2SA1576A
Q541, Q551	2SA1576A
Q401, Q403	2SA1602A

Mark No. Description Part No.

Q202, Q212, Q402	2SC4081
Q6973	DTC114TUA
Q201, Q211	IMT1A
Q6302	UMD3N
Q6972	UMX1N
D6971	1SS355
D6301	RB501V-40

COILS AND FILTERS

L390	LCYA2R7J2520
L604, L606, L607	LCYA470J2520
L608	LCYAR22J2520

CAPACITORS

C309, C315, C318, C319, C323	CCG1179
C326, C342, C348, C357, C360	CCG1179
C373, C377, C388, C391, C6004	CCG1179
C6014, C6047, C6808 (2.2uF/6.3V)	CCG1179
C390	CCSRCH180J50
C142	CCSRCH221J50
C200	CCSRCH331J50
C392	CCSRCH560J50
C393	CCSRCH7R0D50
C6402, C6403	CCSRCH8R0D50
C211	CEVW100M16
C231, C406, C410, C501, C706	CEVW101M16
C710, C718	CEVW101M16
C6015, C6122, C713, C719	CEVW101M4
C201	CEVW220M16
C301, C408, C420, C430	CEVW221M4
C6049, C6050, C6137, C6160	CEVW221M4
C401	CKSQYB225K10
C127, C128, C381, C423, C427	CKSRYB102K50
C433, C6701, C702, C711	CKSRYB102K50
C112-C114, C124, C125, C205	CKSRYB103K50
C213, C214, C355, C705	CKSRYB103K50
C101, C102, C122, C132, C139	CKSRYB104K16
C300	CKSRYB104K16
C394	CKSRYB152K50
C126, C344	CKSRYB223K50
C403, C409, C6301, C6812, C707	CKSRYF104Z25
C230, C232, C233, C411, C412	CKSRYF105Z10
C424, C434, C435, C502-C507	CKSRYF105Z10
C6023, C6030, C6037, C6048, C6064	CKSRYF105Z10
C6081, C6094, C6107, C6119, C6121	CKSRYF105Z10
C6124, C6136, C6149, C6150, C6159	CKSRYF105Z10
C6171, C6172, C6184, C6198, C6401	CKSRYF105Z10
C6404, C6703-C6708, C6974, C6975	CKSRYF105Z10

Mark No.	Description	Part No.
C701, C703, C704, C708, C709		CKSRYF105Z10
C712, C714–C717, C720–C725		CKSRYF105Z10

RESISTORS

R6017, R6932	RAB4C0R0J
R201	RAB4C220J
R211	RAB4C390J
R109, R402, R403, R408, R409	RS1/10S0R0J
R412–R416, R420, R421, R424	RS1/10S0R0J
R427, R480–R482, R488, R6149	RS1/10S0R0J
R6159, R6305, R6701, R712, R713	RS1/10S0R0J
R725, R727	RS1/10S1R0J
R103, R106	RS1/10S1R8J
R104, R107	
R115–R120	RS1/10S4R7J
R125, R152, R330, R331, R6028	RS1/16S1002F
R6035	RS1/16S1002F
R301	RS1/16S1202F
R502, R512, R522, R532, R542	RS1/16S1500F
R552	RS1/16S1500F
R101, R102, R123, R172, R182	RS1/16S5600F
Other Resistors	RS1/16S###J

OTHERS

CN401 PH CONNECTER(SMT)	S13B-PH-SM3
CN103 PH CONNECTER(SMT)	S5B-PH-SM3
FLEXIBLE CABLE	VDA1681
CN104 4P CONNECTOR	VKN1409
CN102 12P CONNECTOR	VKN1416
CN105 21P CONNECTOR	VKN1425
CN101 24P CONNECTOR	VKN1464
CN601, CN602 33P CONNECTOR	VKN1519
KN102 EARTH METAL FITTING	VNF1109
KN103 EARTH METAL FITTING	VNF1109
X6401 (27MHz)	VSS1172
X301 (20MHz)	VSS1186

C JCKB ASSY [VWV1944]

SEMICONDUCTORS

IC204, IC302, IC402	BA4560F
IC301, IC401	DSD1702EG
IC201	DSD1791DBR
IC701, IC751	LA73054
⚠ IC771	MM1565AF
⚠ IC101	NJM78M05FA
IC103, IC104	TC7WU04F
Q203, Q216, Q303, Q403	2SA1576A
Q101, Q801	2SC4081
Q204–Q208, Q210, Q304, Q305	2SD2114K
Q404, Q405	2SD2114K
Q201, Q202, Q214, Q215	DTC114YUA
Q301, Q302, Q401, Q402, Q702	DTC114YUA
Q751	DTC114YUA
D101, D601	1SS355
D102	UDZS6.2B

COILS AND FILTERS

L701, L702 CHIP BEADS	VTL1089
L801 CHIP BEADS	VTL1108

CAPACITORS

Mark No.	Description	Part No.
C327, C328, C427, C428		CCSRCH151J50
C206, C303, C403		CCSRCH331J50
C621, C624		CCSRCH470J50
C302, C308, C321, C322, C402		CEAT101M10
C408, C421, C422		CEAT101M10
C232, C330, C430		CEAT101M16
C712, C713, C718		CEAT102M6R3
C205		CEAT220M50
C109, C116, C201, C203, C304		CEAT331M10
C404		CEAT331M10
C245, C246, C331, C332		CEAT470M16
C431, C432		CEAT470M16
C719, C720		CEAT471M6R3
C102, C118, C732, C771		CEJQ101M16
C804		CEJQ1R0M50
C105, C111, C707, C711, C730		CEJQ221M6R3
C743, C761, C765, C768, C774		CEJQ221M6R3
C805		CEJQ221M6R3
C702–C706, C752–C756, C773		CKSQYB225K10
C701, C751		CKSQYF104Z25
C117, C202, C210, C212, C301		CKSRYB102K50
C401, C734, C737, C766		CKSRYB102K50
C323, C324, C423, C424		CKSRYB152K50
C204, C207–C209, C231, C305		CKSRYF104Z25
C329, C405, C429, C714, C801		CKSRYF104Z25
C806		CKSRYF104Z25
C101, C106, C108, C112–C115		CKSRYF105Z10
C211, C247, C248, C306		CKSRYF105Z10
C325, C326, C406, C425, C426		CKSRYF105Z10
C623, C708–C710, C731, C733		CKSRYF105Z10
C736, C742, C762–C764, C767		CKSRYF105Z10
C772		CKSRYF105Z10
C234, C236		CQMBA152J50
C238, C240, C242, C244		CQMBA561J50

RESISTORS

R323, R326, R423, R426	RN1/16SE1502D
R231, R234, R238, R242	RN1/16SE1801D
R232, R237, R239, R244	RN1/16SE3301D
R321, R322, R421, R422	RN1/16SE8201D
R271, R282, R361, R461	RS1/10S332J
R706, R707	RS1/10S68R0F
R324, R325, R424, R425	RS1/16S1001F
R233, R235, R240, R243	RS1/16S6800F
R704, R708–R710	RS1/16S68R0F
R805	RS1/16S75R0F
Other Resistors	RS1/16S###J

OTHERS

JA801 OPT. LINK OUT 12MB/S	GP1FA502TZ
JA601, JA602 JACK	RKN1004
JA101 JACK	VKB1167
JA102 JACK	VKB1179
CN601 7P CONNECTOR	VKN1211
CN751 19P CONNECTOR	VKN1423
CN101, CN102 33P CONNECTOR	VKN1519
KN101–KN103 EARTH METAL FITTING	VNF1084

D FLKY ASSY [VWG2428]

SEMICONDUCTORS

IC101	PE5374A
-------	---------

<u>Mark No.</u>	<u>Description</u>	<u>Part No.</u>	<u>Mark No.</u>	<u>Description</u>	<u>Part No.</u>
D104		SLR-343VC	CN901	19P CONNECTOR	VKN1279

A SWITCHES AND RELAYS

S103, S105–S108, S117, S119	ASG7013
-----------------------------	---------

CAPACITORS

C183, C199	CKSRYB102K50
C151–C153	CKSRYB103K50
C102, C105	CKSRYF104Z25
C104	CKSRYF104Z50
C182	CKSRYF105Z10

RESISTORS

All Resistors	RS1/16S###J
---------------	-------------

B OTHERS

CN102 CONNECTOR POST	B3B-PH-K
IC104 REMOTE RECEIVER	RPM7240-H4
V101 FLUORESCENT TUBE	VAW1078
CN104 21P CONNECTOR	VKN1225
X101 (5MHz)	VSS1142

E PWSB ASSY [VWG2429]**SWITCHES AND RELAYS**

S101	ASG7013
------	---------

OTHERS

CN103 CONNECTOR POST	B3B-PH-K
----------------------	----------

F POWER SUPPLY UNIT [VWR1366]**OTHERS**

⚠ P301 PROTECTOR(800mA)	AEK7063
⚠ P101 PROTECTOR(1.6A)	AEK7066

G SCRB ASSY [VWV1939]**SEMICONDUCTORS**

IC901	MM1505XN
IC902	MM1507XN
Q904	2SA1576A
Q901, Q902, Q905	2SC4081
D901, D903, D905–D909	1SS355
D911, D912, D914–D916	1SS355

SWITCHES AND RELAYS

RY901–RY905	VSR1017
-------------	---------

CAPACITORS

C904, C914, C932, C933	CCSRCH221J50
C903, C910, C913, C921	CCSRCH391J50
C927	CCSRCH470J50
C929, C930, C937, C943	CEAT101M10
C946, C953	CEAT102M6R3
C901, C902, C907, C909	CKSRYF104Z25
C916, C917, C924, C925, C928	CKSRYF104Z25
C936, C938–C941, C945, C950	CKSRYF104Z25
C935	CKSRYF105Z10

RESISTORS

R936	RS1/10S0R0J
R932, R937, R943, R950, R955	RS1/10S75R0F
R965	RS1/10S75R0F
Other Resistors	RS1/16S###J

OTHERS

JA901, JA902 CONNECTOR	VKB1157
------------------------	---------

6. ADJUSTMENT

6.1 ADJUSTMENT ITEMS AND LOCATION

■ Adjustment Items

[Mechanism Part]

- ① Tangential and Radial Height Coarse Adjustment
- ② DVD Jitter Adjustment

[Electrical Part]



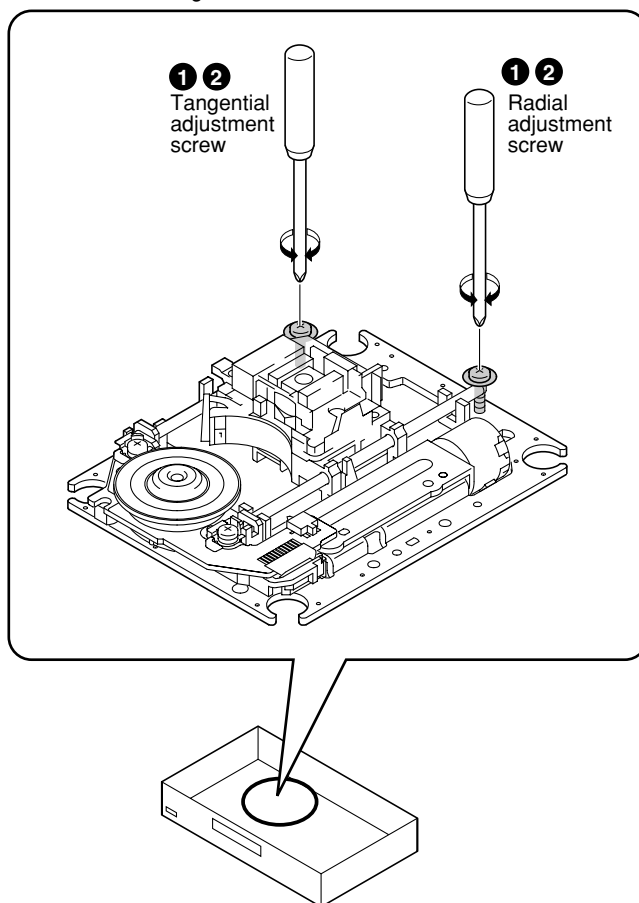

Electrical adjustments are not required.

■ Adjustment Points (Mechanism Part)

Cautions: After adjustment, adjustment screw locks with the Screw tight.

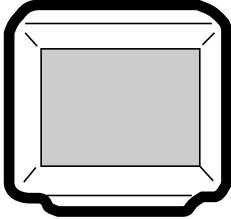
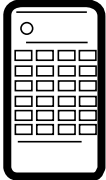

6.2 JIGS AND MEASURING INSTRUMENTS

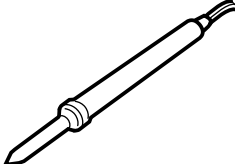
 <p>⊕ Screwdriver (large)</p>	 <p>⊕ Screwdriver (medium)</p>	 <p>TV monitor</p>	 <p>Test mode remote control unit (GGF1381)</p>
 <p>⊕ Precise screwdriver</p>	 <p>DVD test disc (GGV1025)</p>	 <p>Soldering iron</p>	<p>Screw tight (GYL1001)</p>

6.3 NECESSARY ADJUSTMENT POINTS

When

Adjustment Points

■ Exchange Parts of Mechanism Assy

Exchange the Pickup

Mechanical point

①, ②

* After adjustment, screw locks with the Screw tight.

Electric point

Exchange the Traverse Mechanism

Mechanical point

Electric point

Exchange the Spindle Motor

Mechanical point

②

* After adjustment, screw locks with the Screw tight.

Electric point

■ Exchange PCB Assy

Exchange PC Board
LOAB and DVDM ASSYS

Mechanical point

Electric point

6.4 TEST MODE

• The TEST MODE functions that are used only during adjustment are described here. For details, see "7.1.1 TEST MODE".

TEST MODE: ON

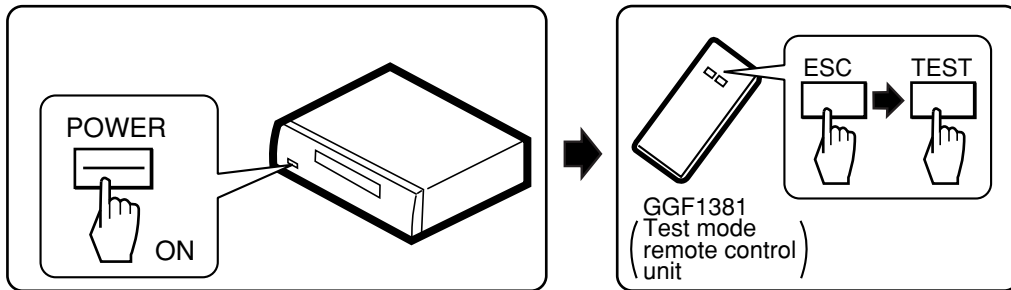

TEST MODE: DISC SET

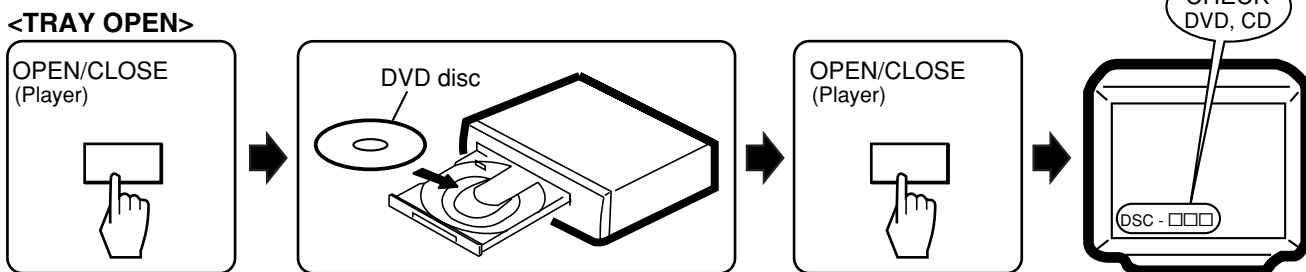

TEST MODE: PLAY

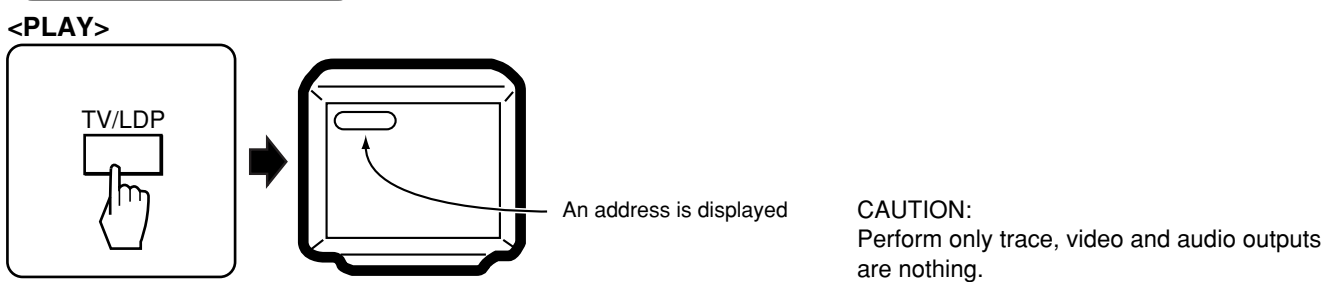

< When playback with the target address of disc (DVD)>

For example, when playback with # 30000

During PLAY +10 → 3 → 0 → 0 → 0 → 0 → CHP/TIM Press keys in order

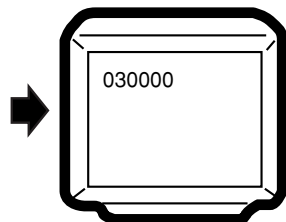

TEST MODE: OFF

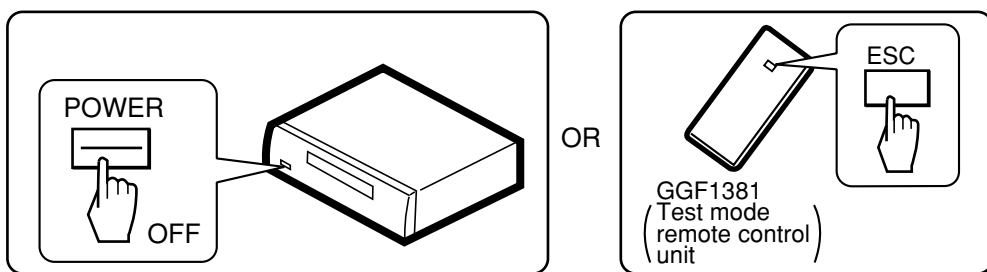

6.5 MECHANISM ADJUSTMENT



1 Tangential and Radial Height Coarse Adjustment

START

- Remove the Loading Mecha. Assy.
- Remove a Spacer for height adjustment attached to the back side (shaded area) of the Loading Mecha. Assy (Float Base) with nippers.

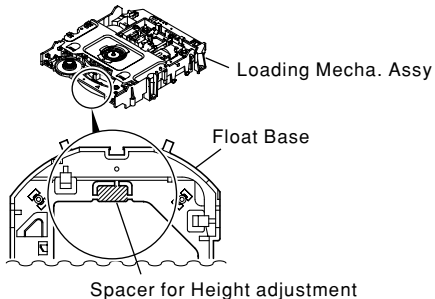

Note:

Before removing the flexible cable for the pickup, soldering of the pickup circuit is necessary.
For details, see "7.1.10 DISASSEMBLY".

Cautions:

Because there is not a Spacer for height adjustment in adjustment after the second time, will keep it at need.
(This parts is Traverse mechanism exclusive use of a model for 2003 years)



Put a spacer between a Tangential (or Radial) adjustment screw and Mechanism Base and turn each screw to adjust the height. (Refer to "6.1 ADJUSTMENT ITEMS AND LOCATION".)

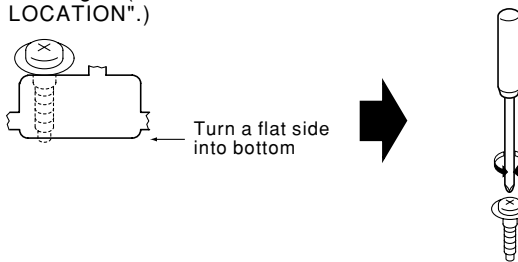

2 DVD Jitter Adjustment

- Playback method of inner and outer address for the purpose is referred to "6.4 TEST MODE".
- Jitter indication of the monitor is referred to "7.1.2 DISPLAY SPECIFICATION OF THE TEST MODE".

Use disc: GGV1025

START

- Test mode
- Play the DVD test disc at outer track (around #200000)

Mechanism Assy

Adjust the Tangential Adjustment Screw so that jitter becomes minimum.



J : Min

- Play the DVD test disc at inner track (around #30000)

Mechanism Assy

Adjust the Radial Adjustment Screw so that jitter becomes minimum.



J : Min

- Play the DVD test disc at outer track (around #200000)

Mechanism Assy

Readjust the Tangential Adjustment Screw so that jitter becomes minimum.



J : Min

Test mode end

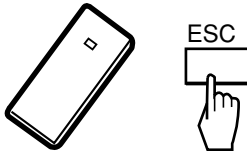
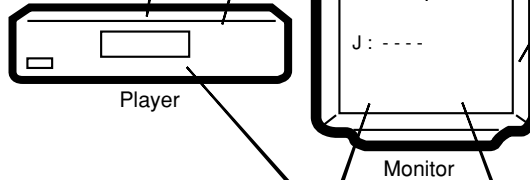



CHECK

Confirm the error rate that is displayed "OK"
(Example ERROR RATE: 6.60e - 6 OK)

Turn the POWER OFF in case of NG once, and perform the adjustment once again.

If error rate is OK, locks a root of tangential and radial adjustment screws with the Screw tight.



Screw tight: GYL1001

Disc playback normally.

- The measurement of block error rate

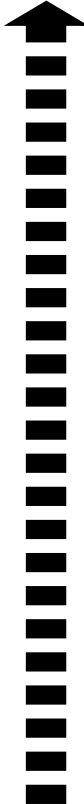
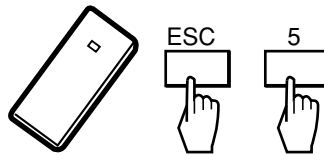

A
B
C
D
E
F

7. GENERAL INFORMATION

7.1 DIAGNOSIS

7.1.1 TEST MODE

■ Test Mode Functional Specification

① Test mode entry

In the power ON state, press the [ESC] (A8-5F) key and [TEST / RANDOM] (A8-5E) key in order of the Test mode remote control unit.

- Light the all FL and LEDs, and goes out the FL and LEDs when pressing the keys of something.
- OSD displays test mode. Refer to the "7.1.2 DISPLAY SPECIFICATION OF THE TEST MODE".

② Release the Test mode

- Turn off the power.
- Press the [ESC] (A8-5F) key of the remote control unit and reset it.

③ Tray open / close

- Press the [REPEAT A-B] (A8 - 48) key of the remote control unit.
- Press the [OPEN / CLOSE] key of the main unit from the stop state.

④ Playback stop

1. Press the [REPEAT] (A8 - 44) key of the remote control unit from the playback state.
2. Press the [STOP] key of the remote control unit or main unit from the playback state.
(Playback stops, but the loaded disc keeps rotating.)

⑤ LD ON

DVD : Press the [TEST] (A8-5E) and [1] (A8-01) keys in order, and turn on the laser diode (650n).
CD : Press the [TEST] (A8-5E) and [4] (A8-04) keys in order, and turn on the laser diode (780n).

⑥ Focus on / sweep

1. Lock the focus by pressing the [TEST] (A8-5E) and [2] (A8-02) keys in order.
2. Repeat focus sweep by pressing the [TEST] (A8-5E) and [3] (A8-03) keys in order.

⑦ Spindle FG servo

CAV : Press the [TEST] (A8-5E) and [5] (A8-05) keys in order, then rise up the spindle and FG servo becomes on.
CLV : Press the [TEST] (A8-5E) and [9] (A8-09) keys in order, then rise up the spindle and FG servo becomes on.

⑧ Tracking open / close

1. Open tracking by pressing the [STEP FWD] (A8-54) key of the remote control unit in the play state.
2. Close tracking by pressing the [STEP REV] (A8-50) key of the remote control unit in the play state.

⑨ Slider servo on/off

1. Turn on the slider servo by pressing the [TEST] (A8-5E) and [CX] (A8-0E) keys in order.
2. Turn off the slider servo by pressing the [TEST] (A8-5E) and [TV/LDP] (A8-0F) keys in order.

⑩ Slider in / out

Slider in : In the tracking off state, press the [SCAN REV] (A8-11) key of the remote control unit.
Slider out : In the tracking off state, press the [SCAN FWD] (A8-10) key of the remote control unit.

⑪ Play (perform only the ID search and trace to the specified location)

Press the [TV/LDP] (A8-0F) key of the remote control unit from the stop state.
Perform only trace, video and audio outputs are nothing.

⑫ Screen display ON/OFF

1. Turn off the display by pressing the [AUDIO] (A8-1E) key of the remote control unit.
2. Turn on the display by pressing the [DISPLAY] (A8-43) key of the remote control unit.

⑬ Search

1. Search address input entry

- It becomes the address input mode when pressing the [+10] (A8-1F) key. (Most significant digit of an address displays "<".)
- In this time, display the last address as the initial state.

2. Search address input

- Press the [0] to [9] (A8-00 to 09) keys of the remote control unit. In the DVD, set an address with hexadecimal.
- In the address input mode, turn to the hexadecimal input by pressing the [PROGRAM] (A8-4C) key (display a "*" mark), and [1] to [6] keys are each input as A to F.
- Hexadecimal input and decimal input can switch with toggle.
- In case of CD, perform only the absolute time search.

3. Search execution

- Press the [CHP/TM] (A8-13) key of the remote control unit.
- After the search, perform only trace and video and audio outputs are nothing.

4. Release the Search address input

- Clear the address by pressing the [CLEAR] (A8-45) key. Release the address input mode when pressing the [CLEAR] key once again.

7.1.2 DISPLAY SPECIFICATION OF THE TEST MODE

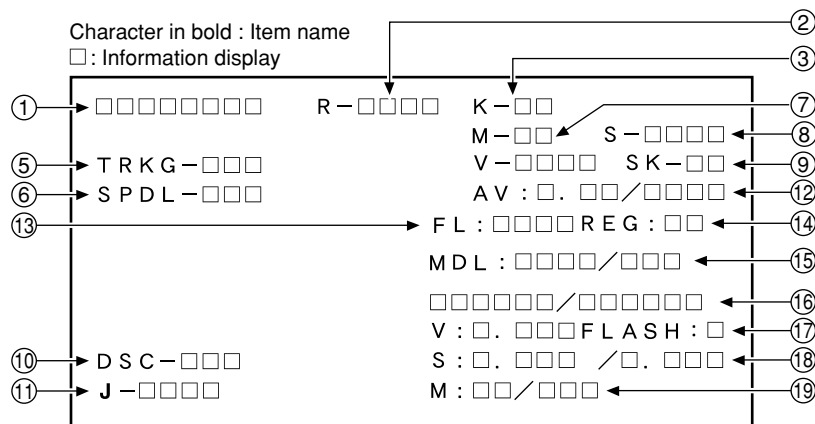

① Address indication

The address being traced is displayed in number.
(as for the DVD, indication of decimal number is possible.)
DVD : ID indication (hexadecimal number, 8 digits)

[*****]

CD : A-TIME (min. sec.) [0000*****]

② Code indication of remote control unit [R-*****]

In case of double code, display a 2nd code.

③ Main unit keycode indication [K-***]

⑤ Tracking status [TRKG-***]

Tracking on : [ON]
Tracking off : [OFF]

⑥ Spindle status [SPDL-***]

[OFF], [ACC/BRK], [CAV], [CLV]

⑦ Mechanism (loading) position value [M-***]

Unknown : [01] or [41]
Open state : [04]
Close state : [08]
During opening : [12]
During closing : [22]

⑧ Slider position [S-****]

In Side Switch ON : [01]
In Side Switch OFF : [00]

⑨ Output video system [V-****]

NTSC system : [NTSC]
PAL system : [PAL]
Automatic setting : [AUTO]

Scart terminal output [SK-***]

(Display only the WY model which can do the output setting of scart terminal.)

VIDEO : [00]
S-VIDEO : [01]
RGB : [02]

⑩ Disc sensing [DSC-***]

The type of discs loaded is displayed.
[DVD], [CD], [VCD], []

⑪ Jitter value [J-****]

⑫ Version of the AV-1 chip / version of firmware

[AV: ** / *****]

⑬ Version of the FL controller [FL: ****]

⑭ Region setting of the player [REG: *]

Setting value : [1] to [6]

⑮ Destination setting of the FL controller

[MDL: **** / ****]

Four characters in the front represent the type of model.
Three characters in the back represent the destination code.
J: /J, K: /KU, /KC, /KU/KC, R: /RL/RD, RAM: /RAM,
LB: /LB, WY: /WY

⑯ Part number of the flash ROM and system controller

[***** / *****]

⑰ Version of the flash ROM [V: *.* **]

Flash ROM size [FLASH = **]

⑱ Revision of the system controller [S: *.* ** / *.* **]

version . revision / build number of the ST core

⑲ Revision of the DVD mechanism controller

[M: ** / ****]

Kinds of version / firmware of the FE.
RAM or ROM

7.1.3 FUNCTIONAL SPECIFICATION OF THE SHORTCUT KEY

Only during normal playback, the following shortcut keys can be assigned by pressing a required key after pressing the ESC key of the remote control unit. To quit, press the ESC key

Command Contents	Conditions	Remote Control Key Name	Remote Control Code
Memory clear and resion / revision indication		CLEAR (*1)	A8-45
Average value measurement of DVD error rate		5 (*1)	A8-05
CD error rate measurement		5 (*1)	A8-05
Aspect : Pan scan		2	AF-A2
Aspect : Letter box		3	AF-A3
Aspect : Wide		4	AF-A4
Digital : AC3		5	AF-A5
Digital : AC-3 > PCM		6	AF-A6
Virtual surround : OFF	Only for models having the corresponding functions	7	AF-A7
Virtual surround : TruSurround		8	AF-A8
Digital output ON		REPEAT A	AF-E8
Digital output OFF		REPEAT B	AF-E4
DTS Digital output ON	Step-up mode : DTS Out	STEP FWD	AF-B7
DTS Digital output OFF	Step-up mode : DTS >Out	STEP REV	AF-B8
Scart terminal output : VIDEO	WY, models equipped with Scart terminal	AUDIO	AF-BE
Scart terminal output : S-VIDEO		SUBTITLE	AF-36
Scart terminal output : RGB		ANGLE	AF-B5
Progressive OFF	Only for progressive models (This command is valid in the stop state after the playback.)	R_SKIP	A3-9D
Progressive ON		F_SKIP	A3-9C
SACD multi audio select play ON	Only for SACD models (This command is valid in the stop state after the tray closed.)	K_ADSEL (DIG/ANA)	A8-0C
SACD multi audio select play OFF		LAS_MEMO	AF-F6
SACD hibrid SACD CD layer ON		KD_PLUS10	AF-BF
SACD hibrid SACD CD layer OFF		CONDITION	AF-B1
Audio 5.1 CH ON	Only for models having the corresponding functions (This command is valid in stop state.)	KD_ENTER	AF-EF
Audio 5.1 CH OFF		SURROUND	AF-61
FL indication of EDC / ID error		CX (*1)	A8-0E
FL indication of ID number		STEREO (*1)	A8-4A
ZOOM ON (X4)		ZOOM	AF-37
ZOOM OFF		<X3 (*1)	A8-59
Service mode indication (error rate indication, etc.)		CHP/TIM (*1)	A8-13
Model information indication		CHAP (*1)	A8-40
Background color change		+10 (*1)	A8-1F
Audio last stage mute ON		9	A8-A9
Audio last stage mute OFF		0	AF-A0
Title search Input mode IN Title No. input Search execution		SIDE A (*1) Numbers (*1) PLAY (*1)	A8-4D A8-00 to A8-09 A8-17
Region confirmation mode		AUDIO (*1) Numbers (*1)	A8-1E A8-01 to A8-08

*1 : Test mode remote control unit

• Service mode indication (ESC + CHP/TIM keys)

ID Address

The error rate is always displayed in exponential notation, e.g., *** e - *, for both DVDs and CDs.

EDC/ID/AV 1 error history (ID Address, EDC/ID/AV 1 Error, last eight errors)

Self-diagnosis functions (If a mechanical error has occurred, the mechanical-error history is also displayed.)

• Calculation of the average error rate (ESC + "5" [Test mode remote control unit] keys)

The average of the last eight error rates is calculated and indicated in exponential notation. After the calculation is completed, "OK" or "NG" is displayed. If "NG" is displayed, the disc tray will open (for both DVDs and CDs)

For DVDs: OK with 5.0e-4 or less, for CDs: OK with 7.6e-3 or less

• Indication of model information (ESC + CHAP keys)

The items from 12 to 19 of the TEST MODE Indications are displayed. However, in the indications, S in the standard test mode is changed to B.E VERSION, and M is changed to F.E VERSION. For details, see 7.1.4.

• Change of the background colors (ESC + "+10" [Test mode remote control unit] keys)

Every time the keys are pressed, the background color is changed between blue and green alternately.

(The green background is used in SETUP NAVIGATOR.)

• Region confirmation mode (ESC + AUDIO [Test mode remote control unit] + "1"- "8" [Test mode remote control unit] keys)

After you press the AUDIO key while holding the ESC key pressed and then input the region number, if the number is different from that set in the unit, an error message is displayed, and the tray opens.

7.1.4 SPECIFICATION OF MODEL INFORMATION DISPLAY

To display model information : Press the ESC key then the CHAP key.

To close the model information display : Press the ESC key.

• Display contents

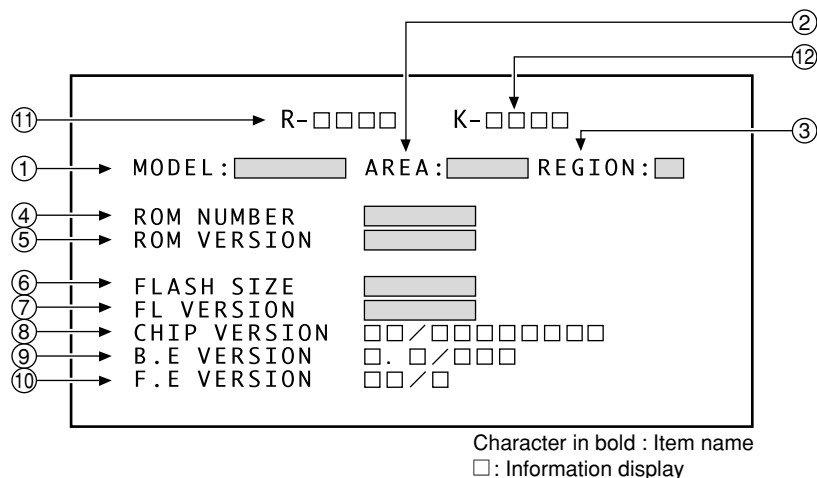

① Model name

Display it according to model information set from the FL controller.

② Destination indication

Display it according to model information set from the FL controller.

③ Region No.

④ Part number

⑤ ROM version

⑥ Flash size

⑦ FL controller version

⑧ CHIP VERSION

Version of ST CHIP

CUT ID / JTAG ID

(two columns) (eight columns)

⑨ B.E VERSION

Version of BACK END (version of ST core software)

□.□ / □□□

softwareVersion . softwareRevision / buildNumber

⑩ F.E VERSION

Version of FRONT END (version of mechanism controller CHIP software)

□□ / □

MainVersion / Kinds of firmware RAM or ROM

⑪ Remote control code

⑫ Key code of Main unit

7.1.5 FUNCTIONAL SPECIFICATION OF THE SERVICE MODE

• EDC / ID error FL display (shortcut function)

EDC/ID error is displayed on the FL display if you press the CX key while holding the ESC key on the TEST MODE remote control unit pressed. To quit while an EDC/ID error is displayed, press the ESC key.

FL display
00 / 00 / 01 *

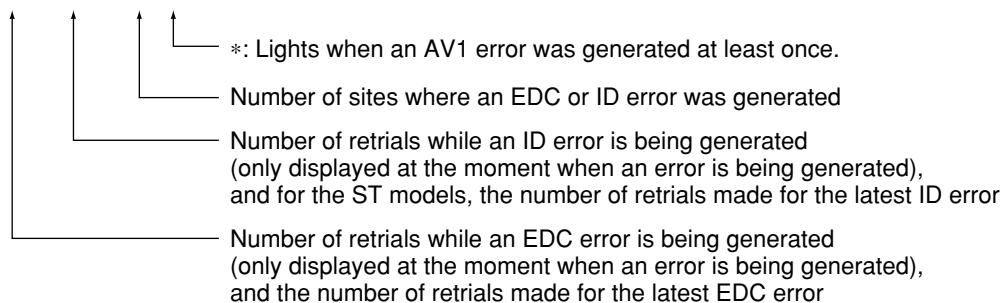

• Display during Service Mode

To enter Service Mode, press the CHP/TIM key while holding the ESC key pressed.
To quit, press the ESC key.

Service mode display

① ID Address

② Error rate (always displayed), in exponential notation

** (****)

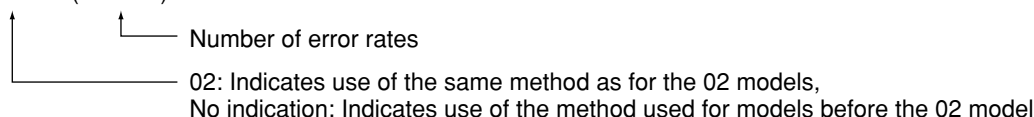

③ EDC/ID/AV1 error history (ID Address, EDC/ID/AV1 errors, last eight errors)

Description of AV1 errors

BIT0: In BE code, an EDC error, FEC I/F buffer overflow, or "not valid" is generated (B.E error)

BIT1: In BE code, the ID is different from that of the target (B.E error)

BIT2: An error was generated in FE-added 2-byte EDC data. (F.E error)

④ Self-diagnosis functions

Whether F.E is normal or not is checked.

FE OK: No abnormality in F.E

FE Error: Abnormality is recognized in F.E.

Pressing the CHP/TIM key again displays the mechanical error history. Each press of the CHP/TIM key changes the displays between the mechanical error history and the Service Mode display.

For details on the mechanical error history, refer to the addendum.

Indication plan contents

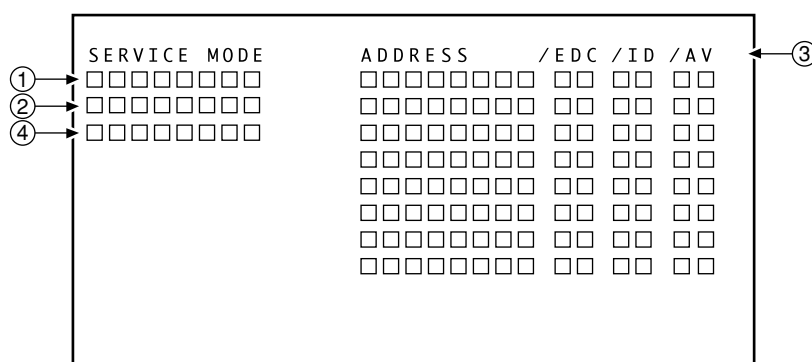

AV1 ERR	BIT		
	2	1	0
00	0	0	0
01	0	0	1
02	0	1	0
03	0	1	1
04	1	0	0
05	1	0	1
06	1	1	0
07	1	1	1

Character in bold : Item name

□ : Information display

7.1.6 MECHANICAL ERROR HISTORY

Only if a mechanical error (FE error) has been generated, a mechanical error history containing up to the last eight errors is displayed if you press the CHP/TIM key in Service Mode.

Errors are displayed in descending order, with the latest one at the top.

Description of the mechanical error history

① Error number

The first two digits are for the error code, and the second two digits are for the servo state.

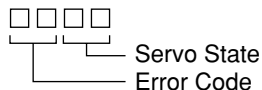

Note: When an error has been generated, if the servo state is "Disc judge," the disc tray opens, and if the servo state is other than "Disc judge," the unit stops (excluding a case of a device error with the error code 0xd*).

② Error number

The elapsed time[μsec] from the time when the system was turned on until an error was generated is displayed. Note: If a later error time is shorter than the previous error time, it means that the unit was turned off then on again.

③ Description of errors

Error messages are displayed. Example: If the error code is 0x13 (Focus lost timeout) and the servo state is 0x05 (Disc judge), the message becomes "Focus lost timeout in Disc judge."

Indication contents

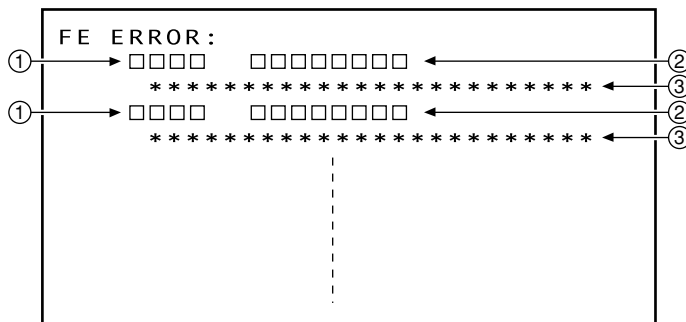

List of the error codes

FOCUS ERROR	0x0*	FOCUS TIMEOUT	0x1*
Focus on error	0x01	Focus on timeout	0x11
Focus off error	0x02	Focus off timeout	0x12
Focus lost error	0x03	Focus lost timeout	0x13
Focus balance adjust error	0x04	Focus balance adjust timeout	0x14
Focus gain adjust error	0x05	Focus gain adjust timeout	0x15
Focus sweep error	0x06	Focus sweep timeout	0x16
TRACKING ERROR	0x2*	TRACKING TIMEOUT	0x3*
Tracking on error	0x21	Tracking on timeout	0x31
Tracking off error	0x22	Tracking off timeout	0x32
Tracking lost error	0x23	Tracking lost timeout	0x33
Tracking balance adjust error	0x24	Tracking balance adjust timeout	0x34
Tracking gain adjust error	0x25	Tracking gain adjust timeout	0x35
STEPPING ERROR	0x4*	STEPPING TIMEOUT	0x5*
Stepping on error	0x41	Stepping on timeout	0x51
Stepping off error	0x42	Stepping off timeout	0x52
Stepping lost error	0x43	Stepping lost timeout	0x53
Stepping move error	0x44	Stepping move timeout	0x54
SPINDLE ERROR	0x6*	SPINDLE TIMEOUT	0x7*
Spindle on error	0x61	Spindle on timeout	0x71
Spindle off error	0x62	Spindle off timeout	0x72
Spindle lost error	0x63	Spindle lost timeout	0x73
Spindle CAV error	0x64	Spindle CAV timeout	0x74
Spindle CLV error	0x65	Spindle CLV timeout	0x75
ACQUISITION ERROR	0x8*	ACQUISITION TIMEOUT	0x9*
PLL lost error	0x83	PLL lost timeout	0x93
DECODER ERROR	0xa*	DECODER TIMEOUT	0xb*
ID lost error	0xa3	ID lost timeout	0xb3
		FAIL SAFE	0xe*
		Unexpected error	0xe1

List of the servo states

0x00	Reset
0x01	Stop (inside position)
0x02	Stop (any position)
0x03	Braking for stop
0x04	New disc
0x05	Disc judge
0x06	Reserved 1
0x07	Playing
0x08	Start up
0x09	Seeking
0x0A	Pausing
0x0B	Reading BCA
0x0C	Reserved 2
0x0D	
0x0E	Tray open
0x0F	Tray moving

Note : 0 x □ □
code
(Only this part is displayed to a display)

ERROR CODE TABLE

Error Name	No.	Causes	Check Item	Possibility of Trouble	Remarks
FOCUS ERROR (0 x 0*)					
Focus on error	0 x 01	Focus on could not be completed	Are not there a dirt or a scratch in the Disc? Does LD become weak? Does the lens move up and down?	1. Pickup 2. Driver 3. Front End IC	
Focus off error	0 x 02	Focus off could not be completed	Unknown		
Focus lost error	0 x 03	Focus servo is lost	Are not there a dirt or a scratch in the Disc? Does LD become weak?	1. Pickup	
Focus balance adjust error	0 x 04	AFB on could not be completed			
Focus gain adjust error	0 x 05	Focus AGC could not be completed			
Focus sweep error	0 x 06				
FOCUS TIMEOUT (0 x 1*)					
Focus on timeout	0 x 11	Did timeout at focus on	Are not there a dirt or a scratch in the Disc? Does LD become weak? Does the lens move up and down?	1. Pickup 2. Driver 3. Front End IC	
Focus off timeout	0 x 12	Did timeout at focus off			
Focus lost timeout	0 x 13	Did timeout at focus backup			
Focus balance adjust timeout	0 x 14	Did timeout at AFB			
Focus gain adjust timeout	0 x 15	Did timeout at AGC			
Focus sweep timeout	0 x 16				
TRACKING ERROR (0 x 2*)					
Tracking on error	0 x 21	Tracking on could not be completed		1. Pickup 2. Driver 3. Front End IC	
Tracking off error	0 x 22	Tracking off could not be completed			
Tracking lost error	0 x 23	Tracking servo is lost		1. Pickup	
Tracking balance adjust error	0 x 24	ATB could not be completed		1. Pickup	
Tracking gain adjust error	0 x 25	AGC could not be completed		1. Pickup	
Tracking jump error	0 x 26	Tracking jump could not be completed			
TRACKING TIMEOUT (0 x 3*)					
Tracking on timeout	0 x 31	Did timeout at tracking on	Are not there a dirt or a scratch in the Disc?	1. Pickup 2. Driver 3. Front End IC	
Tracking off timeout	0 x 32	Did timeout at tracking off			
Tracking lost timeout	0 x 33	Did timeout at tracking backup	Are not there a dirt or a scratch in the Disc?	1. Pickup	
Tracking balance adjust timeout	0 x 34	Did timeout at ATB		1. Pickup	
Tracking gain adjust timeout	0 x 35	Did timeout at AGC		1. Pickup	
Tracking jump timeout	0 x 36	Did timeout at tracking jump			
STEPPING ERROR (0 x 4*)					
Stepping on error	0 x 41	Stepping on could not be completed		1. Pickup 2. Driver 3. Front End IC	
Stepping off error	0 x 42	Stepping off could not be completed			
Stepping lost error	0 x 43	Stepping servo is lost			
Stepping move error	0 x 44	Stepping could not move	Do move to inner and outer periphery of the stepping in the test mode? Do indicate "S-04" at the most inner periphery of the stepping?	1. Stepping motor 2. Inside switch 3. Driver	
STEPPING TIMEOUT (0 x 5*)					
Stepping on timeout	0 x 51	Did timeout at stepping on		1. Pickup 2. Driver 3. Front End IC	
Stepping off timeout	0 x 52	Did timeout at stepping off			
Stepping lost timeout	0 x 53	Did timeout at stepping backup			
Stepping move timeout	0 x 54	Did timeout at stepping movement	Do move to inner and outer periphery of the stepping in the test mode? Do indicate "S-04" at the most inner periphery of the stepping?	1. Stepping motor 2. Inside switch 3. Driver	

Error Name	No.	Causes	Check Item	Possibility of Trouble	Remarks
SPINDLE ERROR (0 x 6*)					
Spindle on error	0 x 61	Spindle on could not be completed			
Spindle off error	0 x 62	Spindle off could not be completed			
Spindle lost error	0 x 63	Spindle lost control			
Spindle CAV error	0 x 64	CAV on could not be completed			
Spindle CLV error	0 x 65	CLV on could not be completed			
SPINDLE TIMEOUT (0 x 7*)					
Spindle on timeout	0 x 71	Did timeout at spindle on			
Spindle off timeout	0 x 72	Did timeout at spindle stop			
Spindle lost timeout	0 x 73	Did timeout at spindle backup	Are not there a dirt or a scratch in the Disc? Is FG output from the driver?	1. Spindle motor 2. Spindle driver	
Spindle CAV timeout	0 x 74	Did timeout at CAV on	Is spindle rotating? Is FG output from the driver? Is the PDM output from Front End?	1. Spindle motor 2. Spindle driver 3. Front End IC	
Spindle CLV timeout	0 x 75	Did timeout at CLV on			
ACQUISITION ERROR (0 x 8*)					
PLL lost error	0 x 83	PLL is lost	Are not there a dirt or a scratch in the Disc?	1. Pickup 2. Front End IC	
ACQUISITION TIMEOUT (0 x 9*)					
PLL lost timeout	0 x 93	Did timeout at PLL backup	Are not there a dirt or a scratch in the Disc?	1. Pickup 2. Front End IC	
DECODER ERROR (0 x a*)					
ID lost error	0 x a3	ID is not readable	Are not there a dirt or a scratch in the Disc?	1. Pickup 2. Front End IC	
DECODER TIMEOUT (0 x b*)					
ID lost timeout	0xb3	Did timeout at ID backup	Are not there a dirt or a scratch in the Disc?	1. Pickup 2. Front End IC	
FAILSAFE (0 x e*)					
Unexpected error	0 x e1	Unexpected error		1. Hardware broken 2. Software bug	

7.1.7 ID NUMBER AND ID DATA SETTING

Caution:

For the DVD players compatible with DVD-RW, for playback of a DVD-RW disc (CPRM), it is necessary that an individual ID number and ID data are set for each player. If the ID number and ID data be not properly set in the manner described below, future operations cannot be guaranteed. The ID number is written on the yellow label at the rear panel of the player.

If there is no yellow label, before downloading FLASH ROM, take note of the ID number set following the procedures outlined in "ID Number Confirmation Mode" on the next page.

Note: Enter ID numbers while the unit is in Stop mode so that the values set will be immediately written to the flash ROM. The following operations are all made with the TEST MODE remote control unit (GGF1381).

■ ID Number Input Mode

① To enter ID Number Input Mode, with no ID number set, such as in a case of immediately after upgrading the firmware, press the ESC key then the STEREO key.

Note: If a previous ID number and ID data, such as a factory-preset ID number and ID data, are maintained, the unit enters ID Number Confirmation Mode when the above keys are pressed. However, if only an ID number is maintained, the unit enters ID Data Input Mode.

- ② Enter a 9-digit ID number. The ID number is also displayed on the FL display.
- ③ By pressing the CLEAR key without having input a number, you can exit this mode. Each press of this key after a number has been input deletes one digit.

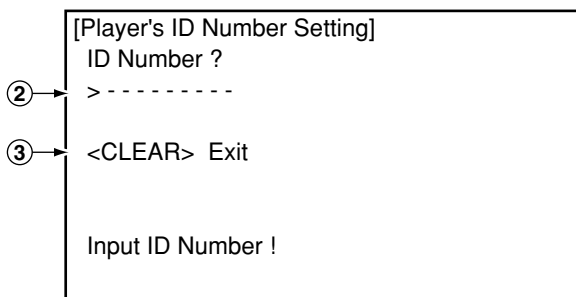

④ After entering all 9 digits, if you press the PLAY key, the unit enters Compare mode. Enter the same ID number again. Only if your two input numbers match, the ID number is set. Compare mode helps eliminate mistyping of the ID number.

Note: If you press the PLAY button before inputting a 9-digit ID number, the unit returns to Step ② without doing anything else.

⑤ After entering all 9 digits, if you press the SEARCH key, the unit unconditionally sets the input number as the ID number. Then the unit automatically enters Player's Data Input Mode. (The SEARCH key is not accepted after all 9 digits have been entered.)

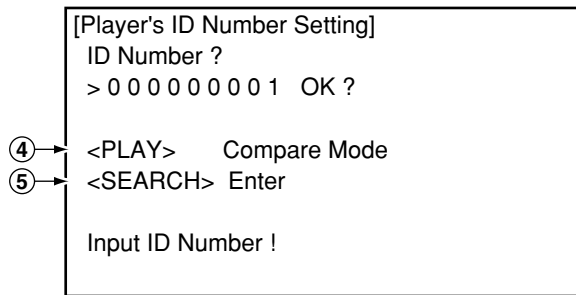

⑥ This display appears when the PLAY key is pressed in Step 4. Enter a 9-digit number to compare. The number is also displayed on the FL display.

⑦ By pressing the CLEAR key without having input a number, the unit returns to Step ② without doing anything else. Each press of this key after a number has been input deletes one digit.

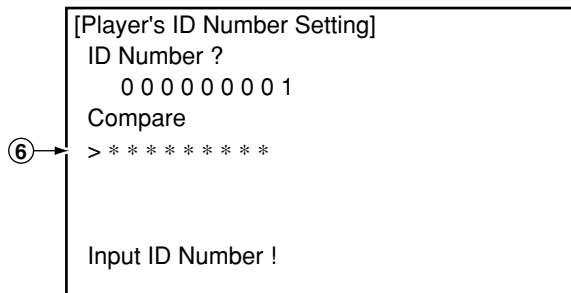

⑧ After entering all 9 digits, if you press the PLAY key, the unit compares the numbers input in Steps ② and ⑥, and only if the numbers match, that number is set as the ID. Then the unit automatically enters ID DATA Input Mode. If the numbers do not match, the disc tray is opened, and the unit exits ID Number Input Mode.

Note: If you press the PLAY button before inputting a 9-digit ID number, the unit returns to Step ⑥ without doing anything else.

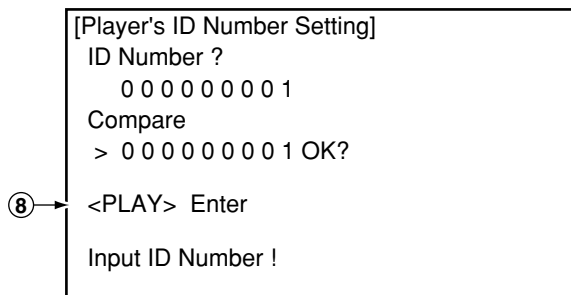

■ ID Number Confirmation Mode

- ① To enter ID Number Confirmation Mode after the ID number and the ID data are set, press the ESC key then the STEREO key.
- ② The ID number already set is displayed.
(It is also displayed on the FL display.)
- ③ Enter a 9-digit number for comparison. This is not required when you only wish to check the ID number visually.
(The number is also displayed on the FL display.)
- ④ By pressing the CLEAR key without having input a number, you can exit this mode. Each press of this key after a number has been input deletes one digit.

• Indication of an ID number already set

An ID number already set is displayed in the following cases:

- 1) When the ESC key then the CLEAR key are pressed, user settings are cleared, then the ID number set is displayed on the screen. In this case, the ID number is not displayed on the FL display.
- 2) When the unit enters ID Number Confirmation Mode by your pressing the ESC key then the CLEAR key, the ID number set is displayed. In this case, the ID number is also displayed on the FL display.
If you only need to confirm the ID number, you can exit this mode by pressing the CLEAR key or turning off the power.

• Indication when no ID number is set

If no ID number is set, the message "No ID Number!" flashes on the screen and FL display for a few seconds after the power is turned on or during Stop mode.

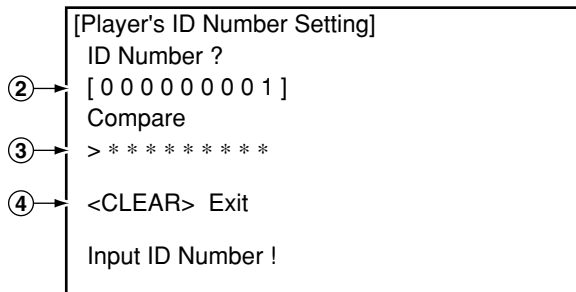

- ⑤ After entering all 9 digits, if you press the PLAY key, the unit compares the number entered in Step ② with the ID number set, and only if the numbers match, the unit automatically exits ID Number Confirmation Mode. If an ID data has not been entered, the unit enters ID DATA Input Mode. If the numbers do not match, the disc tray is opened, and the unit exits ID Number Confirmation Mode.

Note: If you press the PLAY button before inputting a 9-digit ID number, the unit returns to Step ④ without doing anything else.

- ⑥ After entering all 9 digits, if you press the STOP key, the unit compares the number entered in Step ③ with the ID number set, and only if the numbers match, the unit automatically deletes the ID number and exits this mode. If the numbers do not match, the disc tray is opened, and the unit exits this mode. (The STOP key is not accepted after all 9 digits have been entered.)

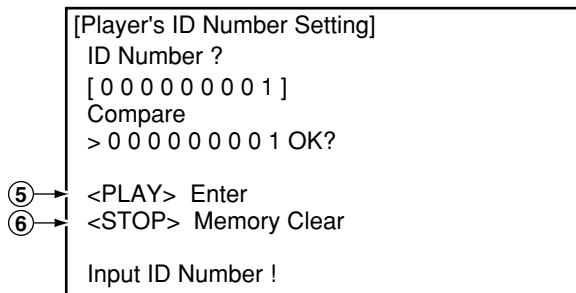

■ ID DATA Input Mode

- ① To enter ID DATA Input Mode, with the ID number set, press the ESC key then the STEREO key.
- ② When the STEREO key is pressed, the unit enters ID DATA Input Mode.

```

[Player's ID Number Setting]
ID Number ?
[ 0 0 0 0 0 0 0 1 ]
Compare
> * * * * *
<CLEAR> Exit
<STEREO> ID Data Setting Mode

Input ID Number !
  
```



- ③ If the DVD DATA DISC (GGV1133) is loaded in this mode, the unit automatically starts reading the data. (If the DVD DATA DISC has already been loaded, the unit does not start reading the data. In this case, open then close the tray.)

- ④ To exit this mode, press the CLEAR key. While data are being read from the DVD DATA DISC (GGV1133), you cannot exit this mode.

```

[Player's Data Input Mode]

<CLEAR> Exit

Insert The ID Data Disc !
  
```



- ⑤ When writing of the data read from the disc to flash ROM is completed, "Rom Write OK!" is displayed. After seeing this message, you can exit this mode by pressing the CLEAR key.

Note: Whether or not the data have been written to flash ROM can be confirmed by watching for the message "Rom Write OK!" being displayed after the disc is read.

```

[Player's Data Input Mode]

Rom Write OK!

<CLEAR> Exit
  
```



- ⑥ If the data cannot be read from the disc, "Disc Error!" is displayed on the screen, and the disc is ejected.

```

[Player's Data Input Mode]

Disc Error!

<CLEAR> Exit
  
```

• Indication when the data have not been set
If no ID data are set after the ID number is changed, the message "NO ID DATA" flashes on the screen and FL display for a few seconds after the power is turned on or during Stop mode.

7.1.8 TROUBLE SHOOTING

Check the error history first. (See "7.1.6 MECHANICAL ERROR HISTORY")

When the error history is not displayed, see the below table.

No.	Symptoms	Diagnosis Contents	Possible Defective Points
1	The power is not turned on.	Check the voltage of EV+3.3V, -28V and FLDC on the POWER SUPPLY Unit.	POWER SUPPLY Unit
		Are wires of output connector (POWER SUPPLY Unit) and CN401 (DVDM Assy) disconnected or damaged ?	Connector / cable
		Check that the voltage at IC101-pin 22 (KEY0) on the FLKY Assy becomes 0 V when the POWER key is pressed and 3.3 V when it is released.	FLKY Assy Tact SW (when operation of only the POWER key on the main unit is not accepted)
		Check that the voltage at IC101-pin 17 (SEL IR) on the FLKY Assy is in the range between 0 and 3.3 V while receiving signals from the remote control unit when any key on it is pressed.	FLKY Assy Remote receiver section (when operation of only the POWER key on the remote control unit is not accepted)
2	An opening screen is not displayed on the monitor (The FL display lights. The mechanism does not work.)	Is the level at both IC101-pin 12 (XRESET) and pin 11 (POWER ON) on the FLKY Assy "H" ?	FLKY Assy FL Control IC (IC101)
		<ul style="list-style-type: none"> Check the voltage of E+6V and SW+1.8V on the POWER SUPPLY Unit. Check the voltage of P-CONT is about 3V on the POWER SUPPLY Unit. 	POWER SUPPLY Unit
		Check that the following voltage are output : IC401-pin 1 : 5V, IC402-pin 3 : 3.3V, IC403-pin 5 : 3.3V on the DVDM Assy.	DVDM Assy 5V Regulator IC (IC401) 3.3V Regulator IC (IC402) 3.3V Regulator IC (IC403)
		Are resonators (X601 : 27MHz, X301 : 20MHz) on the DVDM Assy oscillating ?	DVDM Assy Crystal resonator (X601 and X301)
		Refer to contents of an FE error displayed on the FL display. (I2C communication line defectiveness, etc.)	DVDM Assy Front End IC (IC301)
		<ul style="list-style-type: none"> Is a signal input into IC603-pin26 (CE_FLASH) on the DVDM Assy ? (Is a signal fluctuating for several seconds after the power is turned on ?) → Communication with flash ROM. Are the signals input into IC602-pin 16 (SMIWE), pin 19 (SMICS0) and pin 38 (SMICLK) on the DVDM Assy ? (Is a signal fluctuating ?) → Communication with SDRAM 	DVDM Assy Back End IC (IC601) Flash ROM (IC603) SDRAM (IC602)
		Is a signal output from IC603-pin 28 (CPU_OE) on the DVDM Assy? (Is a signal fluctuating for several seconds after the power is turned on ?)	DVDM Assy Flash ROM (IC603)
		Is a signal input into IC101-pin 16 (FP_ACK) on the FLKY Assy ? (Is a signal fluctuating ?) → Communication with FL Control IC	DVDM Assy Back End IC (IC601) FLKY Assy FL Control IC (IC101)
		Is a signal output from IC101-pin 10 (XRDY) on the FLKY Assy ? (Is a signal fluctuating in the range of 0-3V ?)	FLKY Assy FL Control IC (IC101)
		Are the signals output from IC101-pin 9, pin 8 and pin 7 on the FLKY Assy ? (in the range of 0-3V)	DVDM Assy Back End IC (IC601) – FLKY Assy FL Control IC (IC101) communication line
3	An opening screen is not displayed on the monitor (The FL display lights. The mechanism does not work.)	Check the video signal path between Back End IC (DVDM Assy IC601) and video-out terminal (see the block diagram)	DVDM Assy, JCKB Assy Video circuit after Back End IC (IC601)

No.	Symptoms	Diagnosis Contents	Possible Defective Points
4	A tray cannot be opened. (An opening screen is displayed on the monitor)	Does the voltage of CN103-pin 3 and pin 5 on the DVDM Assy change normally ? Pin 3 (XCLOSE): Tray is fully closed: "H" Pin 5 (OPEN): Tray is fully opened: "H"	DVDM Assy Front End IC (IC301) Tray SW
		Is a LOAD-DRV signal reaching ?	DVDM Assy Back End IC (IC601)
		Are the signals output from IC101 pin 36 and pin 37 (CN103 pin 1 and pin 2) on the DVDM Assy ? Pin 36: Approx. 6V during opening tray approx. 0V during closing tray. Pin 37: Approx. 0V during opening tray approx. 6V during closing tray.	DVDM Assy FTS Driver IC (IC101)
		Are wires of CN104 and CN103 on the DVDM Assy disconnected or damaged ?	Connector / cable
		Does the voltage of CN102-pin 12 change by pressing the Inside switch.	Inside switch
5	Playback impossible (no focusing)	Are the signals output from IC101-pin 34 (F_DRV) and pin 35 (F_RTN) on the DVDM Assy ?	DVDM Assy FTS Driver IC (IC101)
		Does 650-nm LD emit light ? Does a pickup lens move up / down ? Does an actuator spring bend ?	Pickup
		Are plastic parts damaged ? Or is a shaft detached ? Is the turntable detached or tilted ?	Mechanism section (motor)
		Is flexible cable of CN101 on the DVDM Assy disconnected or damaged ?	Flexible cable / connector
		Is signal output from IC301-pin 33 (FACT) on the DVDM Assy ? (Device control of about 500 mV is output usually. It is fluctuated by about ± 100 mV with focus up / down.)	DVDM Assy Front End IC (IC301)
6	Playback impossible (Spindle does not turn)	Are the signals output from IC101-pin 12 (A3), pin 13 (A2) and pin 14 (A1) on the DVDM Assy ? Is pin 41 (PS) fixed LOW and is pin 38 (SB) fixed HIGH ?	DVDM Assy FTS Driver IC (IC101)
		Is there any part detached from the spindle motor ? Or Is there any foreign object lodged in it ?	Mechanism section (Spindle motor)
		Are wires of CN102 on the DVDM Assy disconnected or damaged ?	Flexible cable / connector
		Is signal output from IC301-pin 44 (SPDL_PDM) on the DVDM Assy ?	DVDM Assy Front End IC (IC301)
7	Playback impossible (Playback stops)	Does 650-nm LD deteriorate ? If the voltage at both ends of R201 on the DVDM Assy is 0.7 V or more, the 650-nm LD is definitely deteriorated.	650-nm LD deteriorated. (When playback of a DVD is impossible)
		Does 780-nm LD deteriorate ? If the voltage at both ends of R211 on the DVDM Assy is 1.2 V or more, the 780-nm LD is definitely deteriorated.	780-nm LD deteriorated. (When playback of a CD is impossible)
		Is there abnormality in FG waveform ?	DVDM Assy FG output : FTS Driver IC (IC101)
		Are there scratches or dirt on the disc ?	Disc
8	Picture disturbance during playback (block noise, freeze, other)	Are there scratches or dirt on the disc ? Is there a problem with the format of the disc ?	Disc
9	No sound (Picture is normal)	Check the waveform (BCK, LRCK, MCLK, DATA).	DVDM Assy Back End IC (IC601)
		Is signal output from signal (IC201-pin 17, pin 18, pin 13, pin 12) on the JCKB Assy ?	JCKB Assy Audio Dac IC (IC201)

7.1.9 SEQUENCE AFTER POWER ON

Flow chart from power on to the picture output

A
B
C
D
E
F

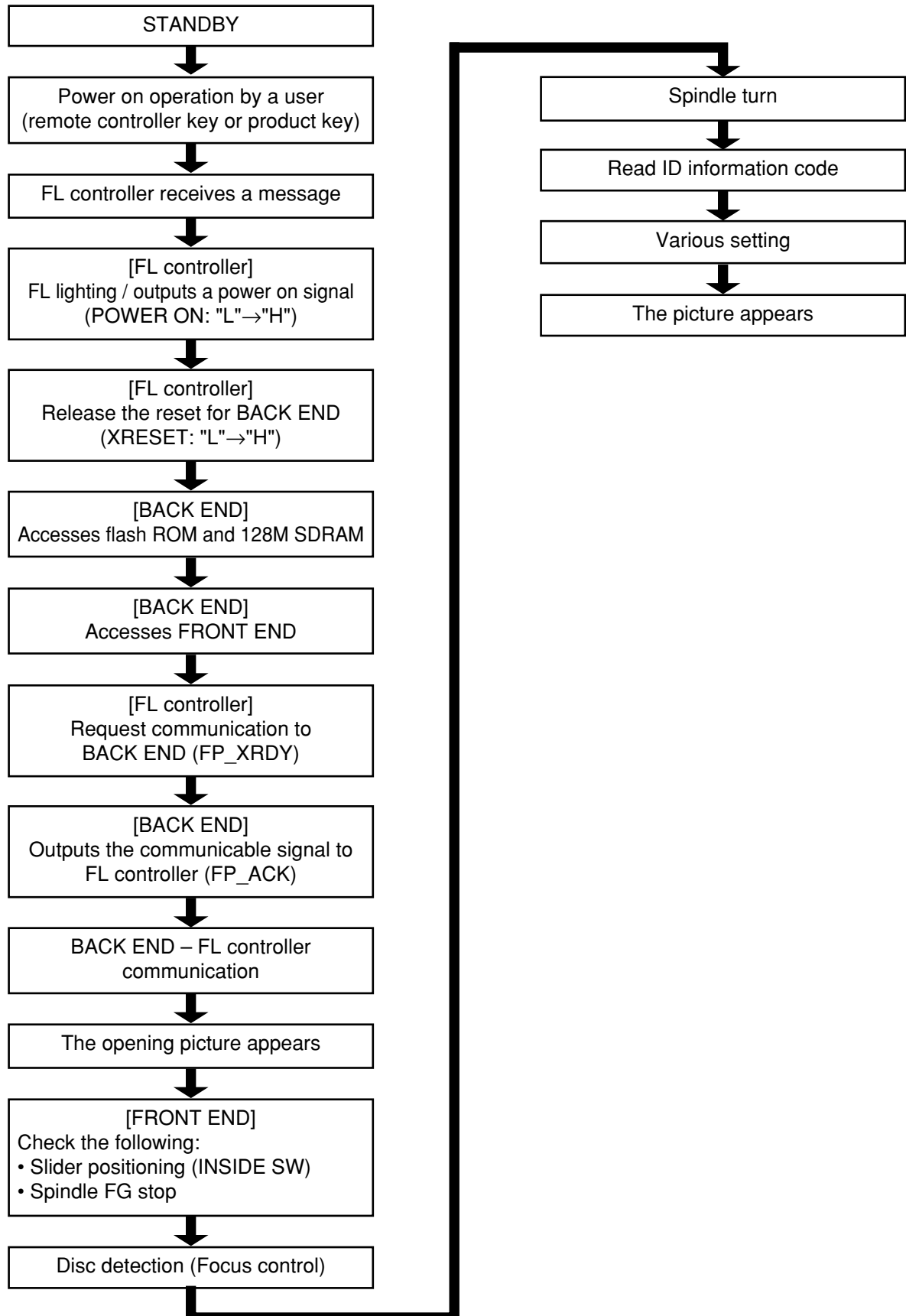





7.1.10 DISASSEMBLY

Note: For performing the diagnosis shown below, the following jig cables for service are required:
 • GGD1330 x2

Diagnosis of the PCBs

Procedures ; SCRB Assy : 1 → 2 → 3
 JCKB Assy : 1 → 2 → 3 → 4
 DVDM Assy : 1 → 2 → 5

1 Bonnet and Tray Panel

- ① Remove the Bonnet by removing the five screws.
- ② Press the  STANDBY/ON button to turn on the power.
- ③ Press the  button to open the tray.
- ④ Remove the tray panel.
- ⑤ Press the  button to close the tray.
- ⑥ Press the  STANDBY/ON button to turn off the power.

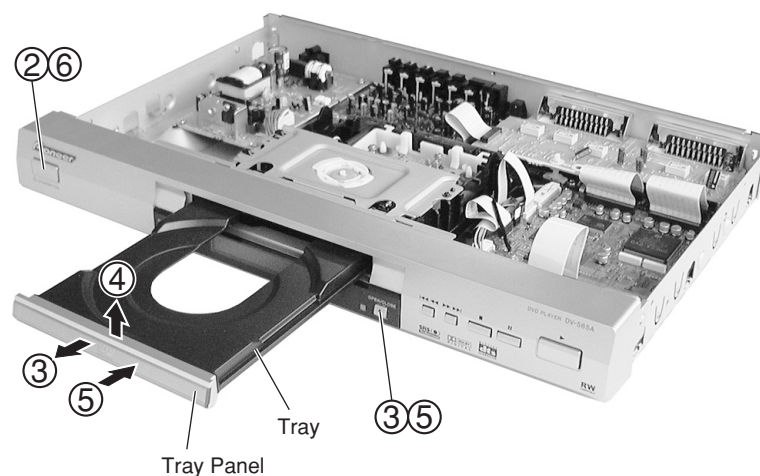

How to open the Tray when the power cannot be on

Insert a screwdriver (small) into the slit located at the bottom of the unit, and slide the projection of the drive gear in the loading mecha. assy in the direction of the arrow, as indicated in the photo. If the tray pops out a little, fully pull it out by a hand.

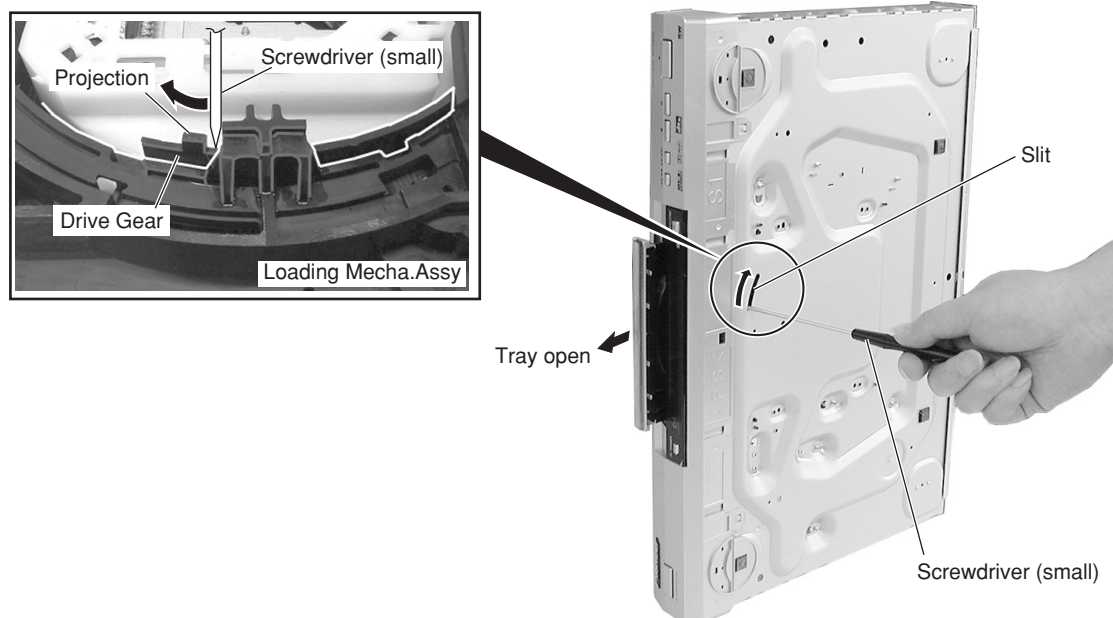

2 Front Panel Section

- ① Remove the six hooks.
- ② Remove the front panel section.

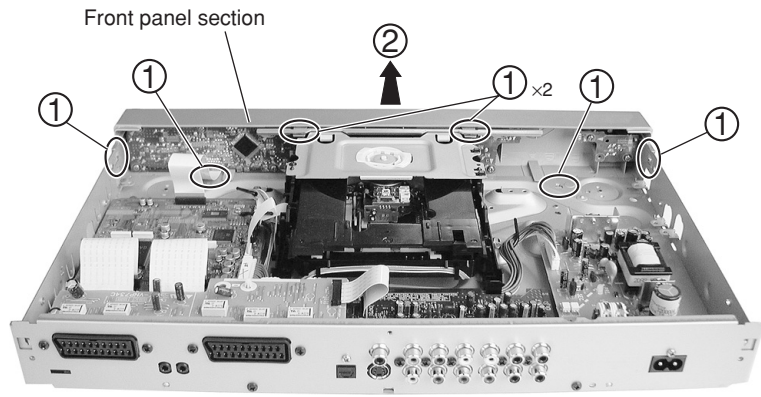

3 SCRB Assy

- ① Remove the four screws.
- ② Disconnect the flexible cable.
- ③ Remove the PCB holder.
- ④ Remove the SCRB Assy.

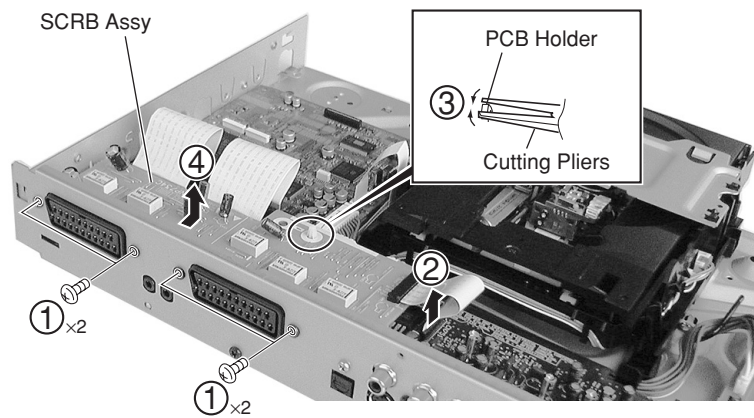

4 JCKB Assy

- ① Remove the rear panel by removing the nine screws.

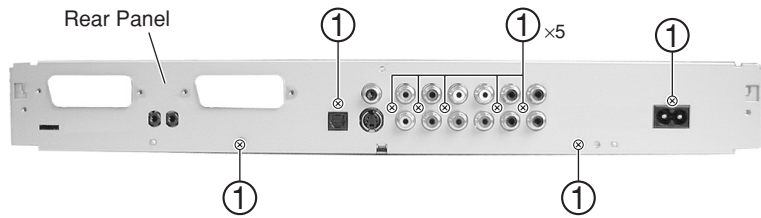

- ② Remove the five screws.

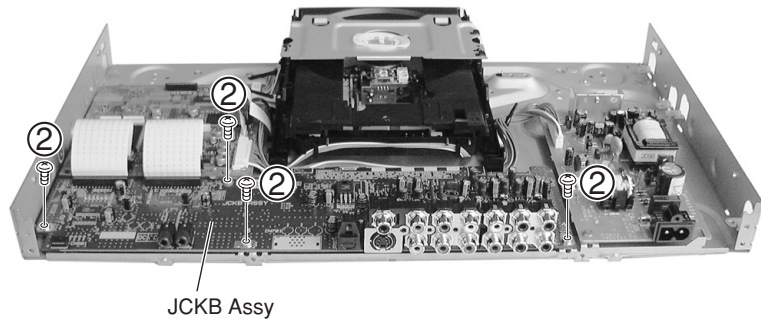

- ③ Remove the JCKB Assy and stand it against the other parts.

↓
Diagnosis

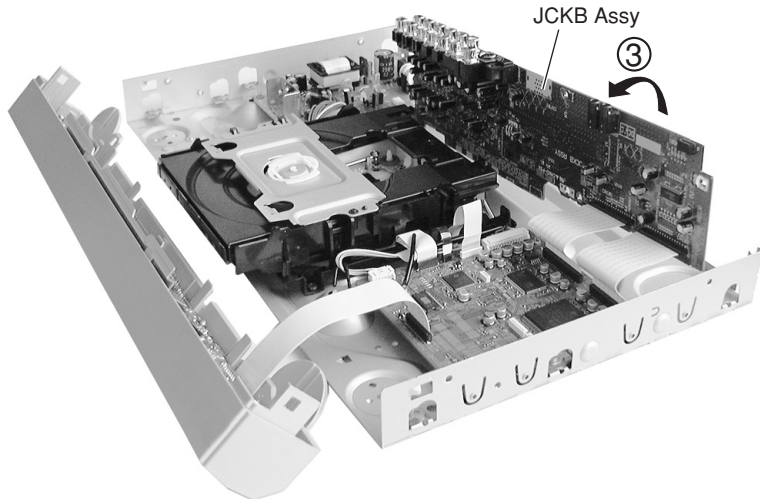

5 DVDM Assy

- ① Exchange the two flexible cables for the two jig cables.
- ② Remove the three screws.

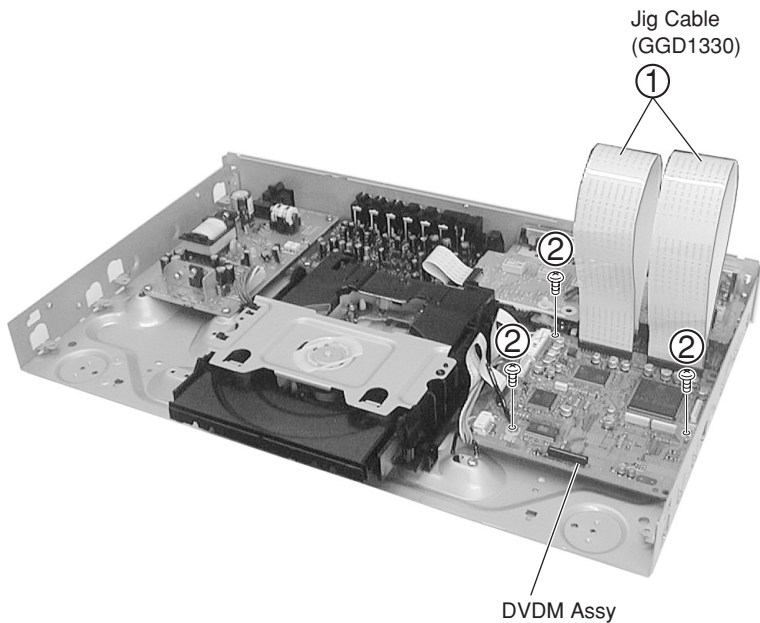

- ③ Remove the DVDM Assy and stand it against the other parts.

↓
Diagnosis

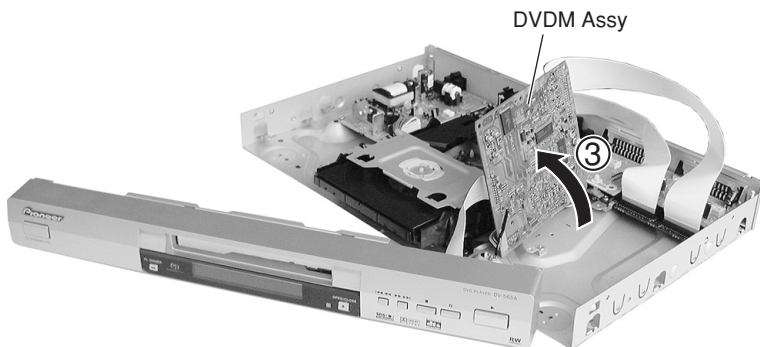

Removing the Traverse Mecha. Assy-S and Pickup Assy-S

1 Loading Mecha. Assy

- ① Remove the bridge by removing the one screw.
- ② Pull out the tray, then remove it by pressing the hook.
- ③ Short-circuit two points of C and D by soldering.

Note: After replacement, connect the flexible cable, then remove the soldered joint (open).

- ④ Remove the four connectors from the Loading Mecha. Assy.
- ⑤ Remove the four screws that secure the Loading Mecha. Assy to the unit.

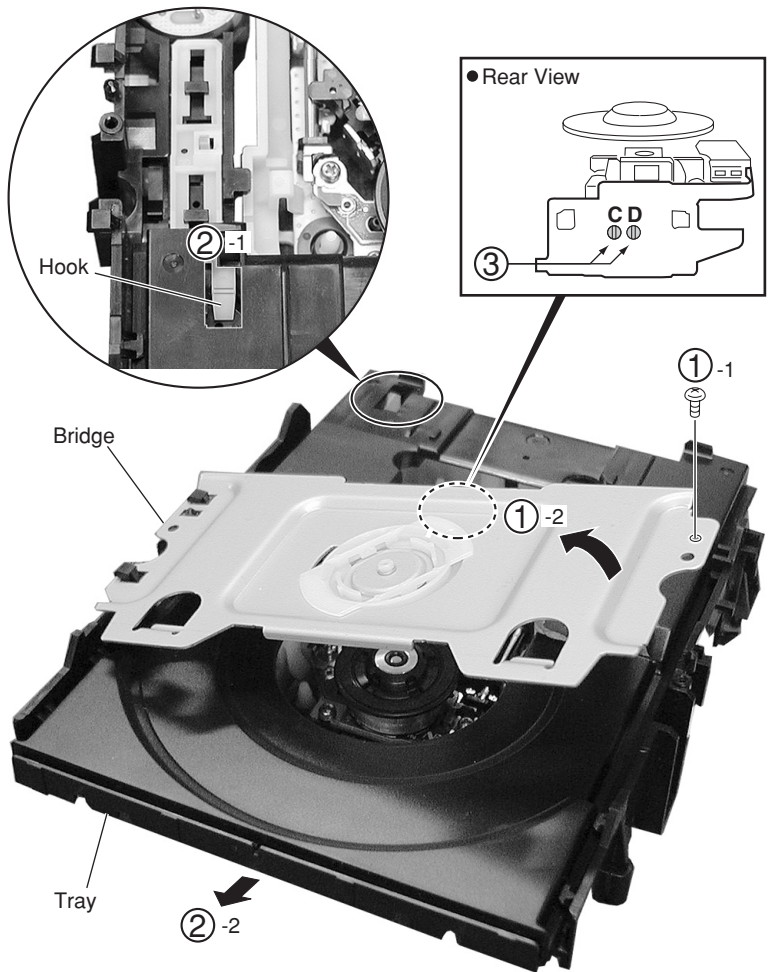

Note when reinserting the Tray

When reinserting the Tray, first align the triangle printed on the Loading Base and the pin of the Drive Cam, then insert the Tray.

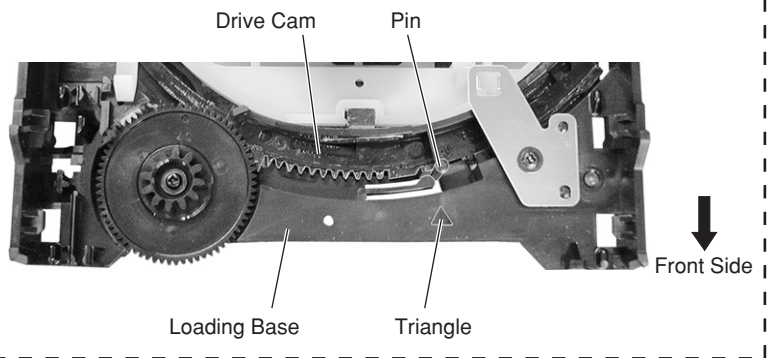

2 Traverse Mecha. Assy-S

- ① Dislodge the flexible cables from their factory placement.

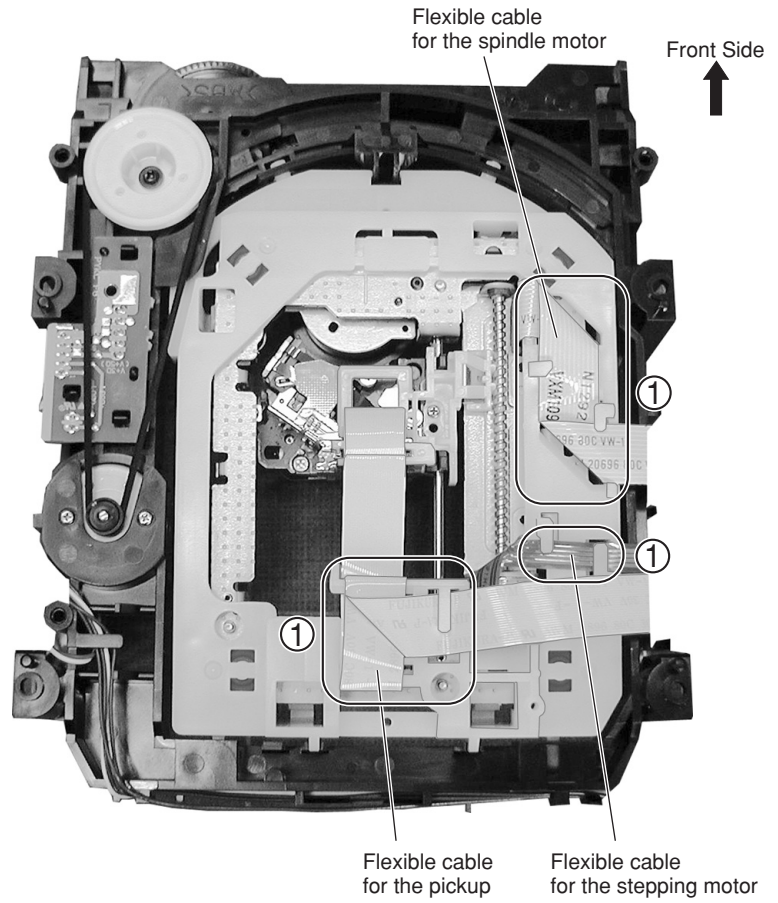

● Bottom View

- ② Remove the four hooks.
- ③ Remove the Traverse Mecha. Assy-S.

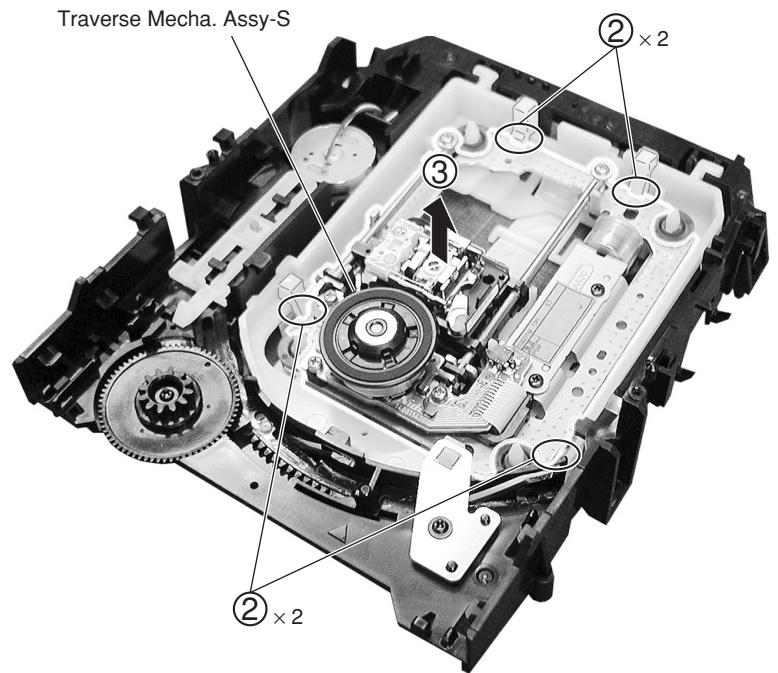

3 Pickup Assy-S

Note: The Pickup Assy-S can be removed without removing the Traverse Mecha. Assy-S. (shown as Step 2.)

- ① Dislodge the flexible cable for the pickup from its packaged placement.
- ② Remove the flexible cable for the pickup.

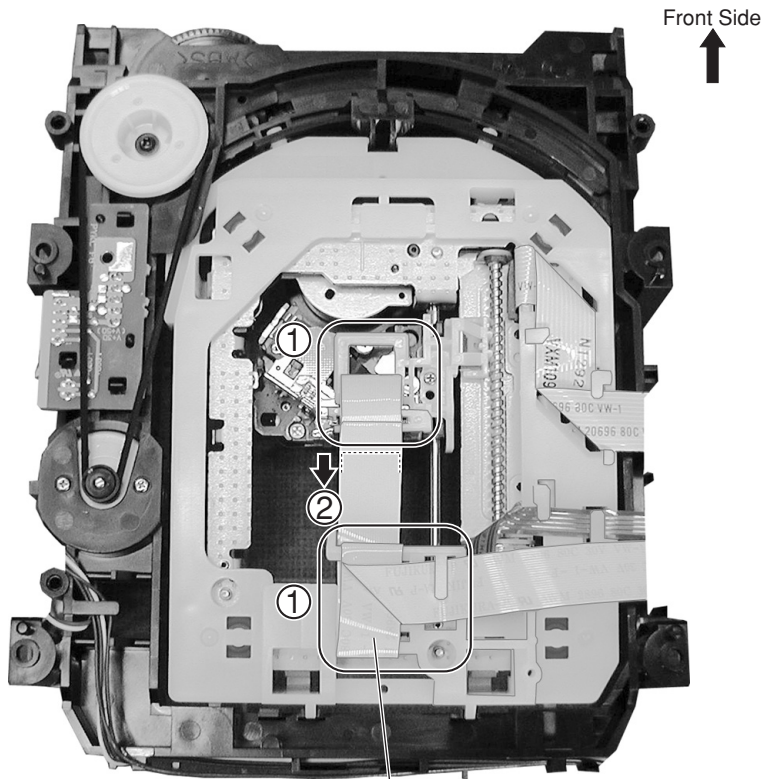

Flexible cable for the pickup

● Bottom View

- ③ Remove the two adjustment screws and two adjustment springs.
- ④ Remove the Pickup Assy-S.

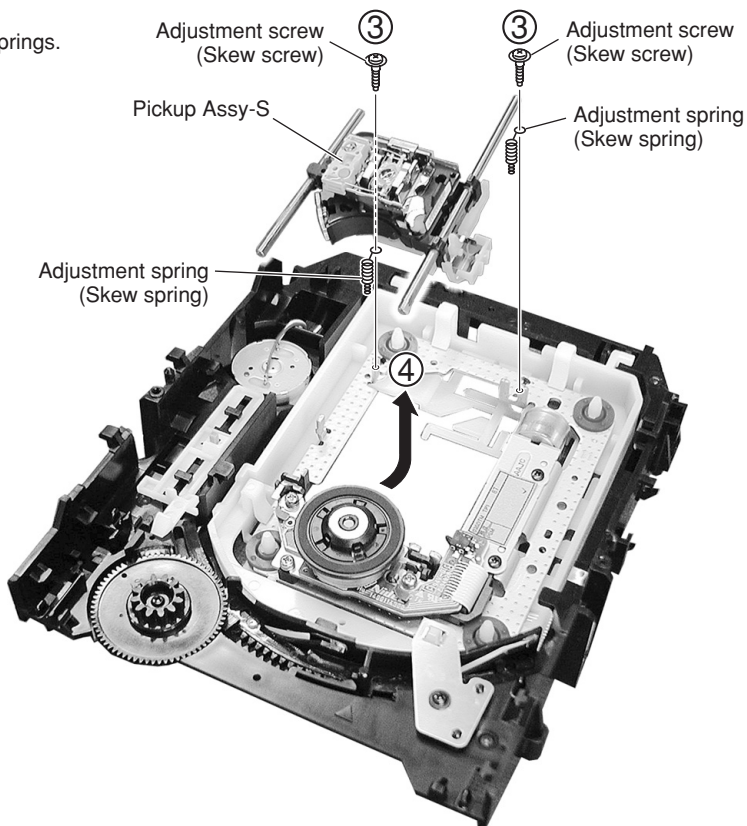

⑤ Remove the two screws.

Note: The screws are secured with epoxy. Make sure to apply epoxy after reattaching the screws.

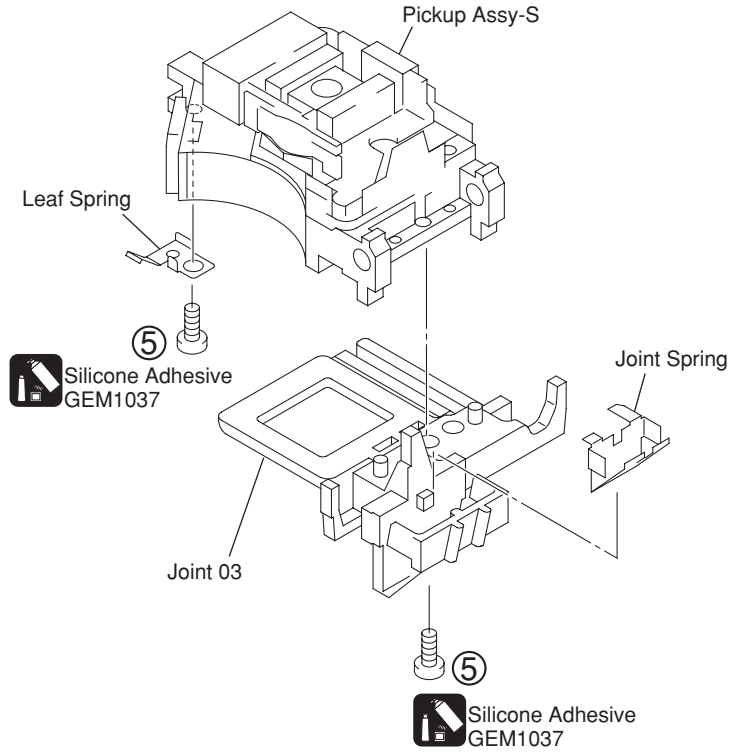

Arrangement of the flexible cable for the spindle motor

■ : Conductive surface

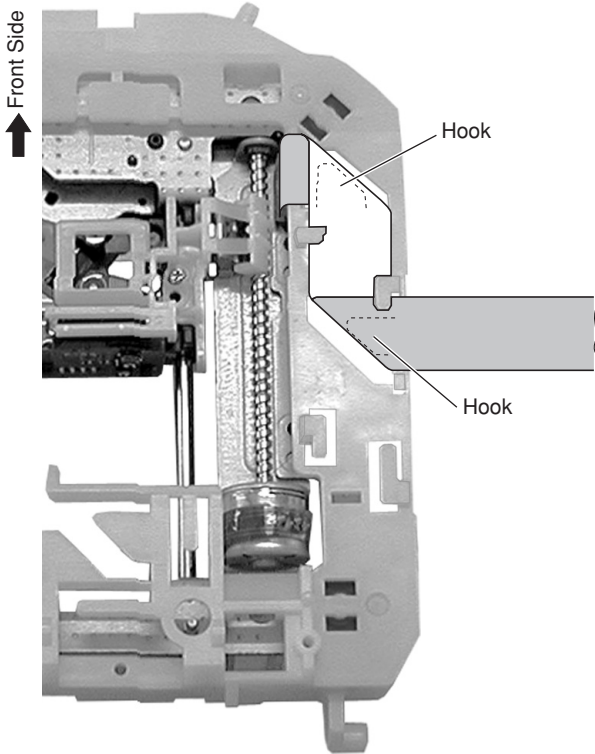

● Bottom View

Arrangement of the flexible cable for the stepping motor

■ : Conductive surface

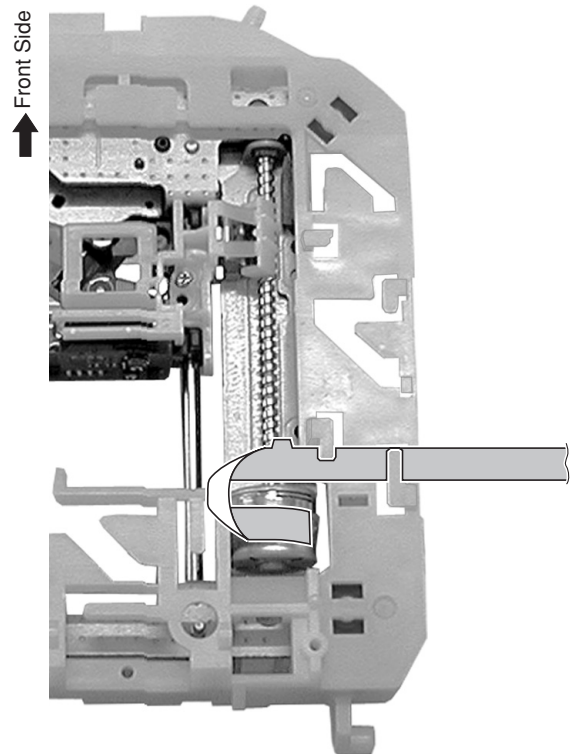

● Bottom View

Arrangement of the flexible cable for the pickup

█ : Conductive surface

Note:
Be sure to move the Pickup Assy-S to the innermost perimeter.

- ① Fold the flexible cable inward at the position of the reference line.
- ② Attach the flexible cable of the pickup to the connector.
- ③ Fold the flexible cable of the pickup with the backing inward.

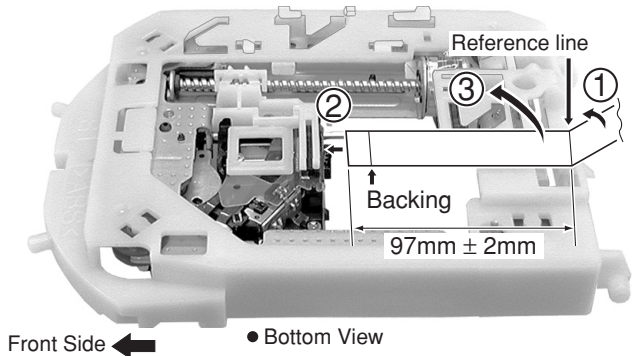

- ⑦ Pass the flexible cable below the hook, and fold it back.
- Make sure that the cable does not have any slack

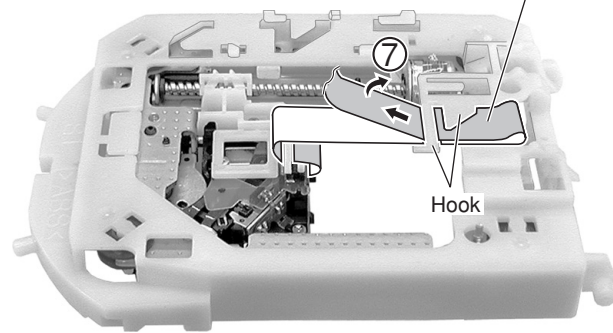

- ⑧ Fold the flexible cable back at the hook.

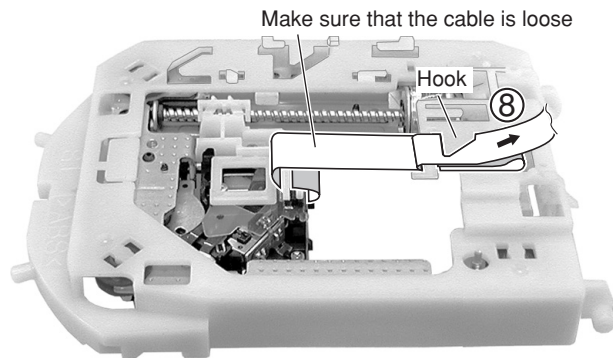

- ④ Pass the flexible cable through the hook not allowing any slack.

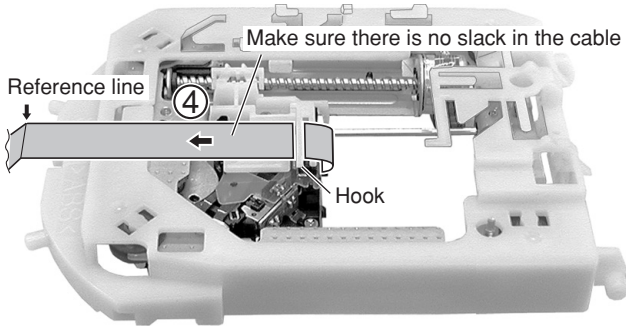

- ⑨ Fold the flexible cable along the hook.

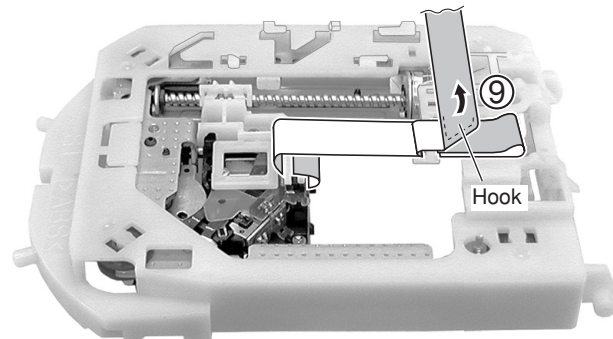

- ⑤ Fold the flexible cable as indicated in the photo.
- ⑥ Hook the part folded in Step ① to the hook.

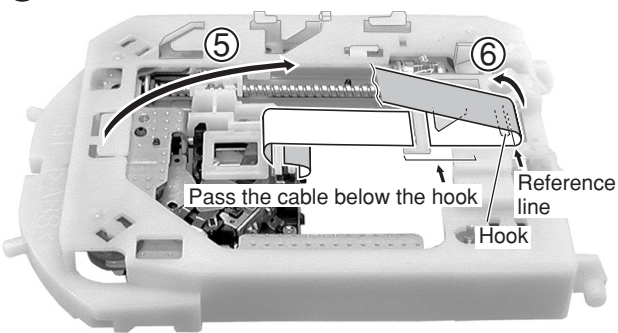

7.2 IC

• The information shown in the list is basic information and may not correspond exactly to that shown in the schematic diagrams.

• List of IC

STM6316ATXXA, STI5588CVB, SAA7893HL/C2, M63108FP, PE5374A

■ STM6316ATXXA (DVDM ASSY : IC301)

• FRONT END IC

● Block Diagram

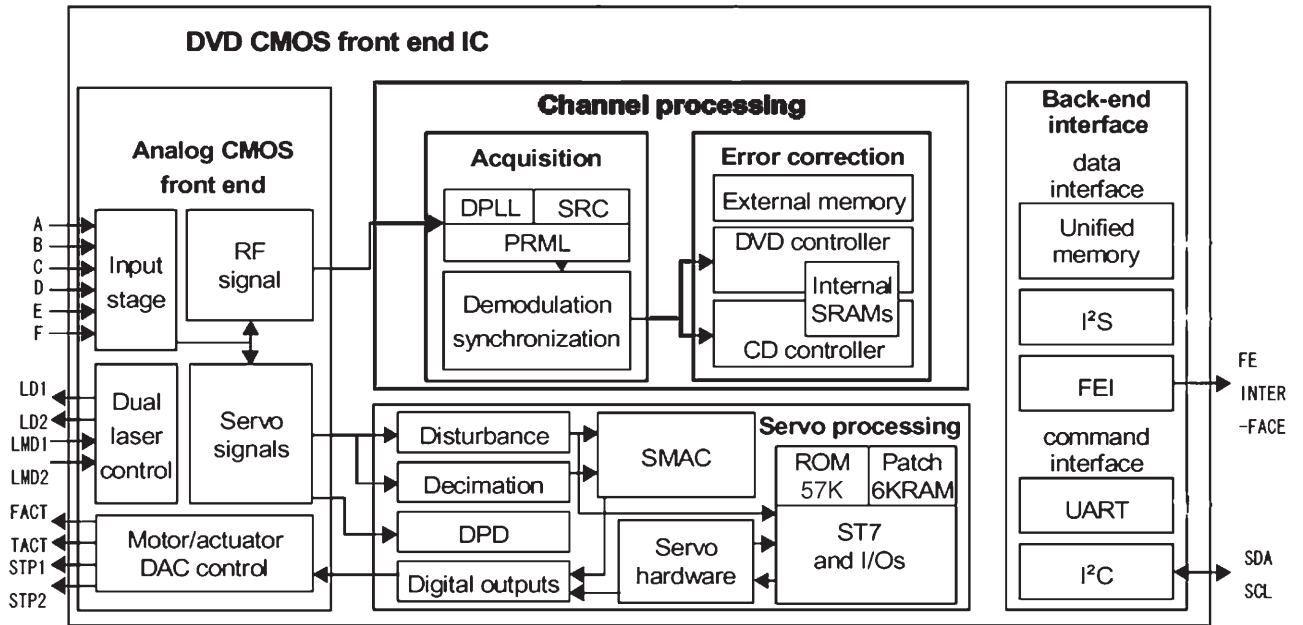

● Pin Function

No.	PIN name	description	detail
1	IREF	12.7kF	Analog block reference part
2	GNDAI	GND A	analog gnd
3	RFIN	capacitor	RF signal C association input to a demodulation block
4	RFOUT	capacitor	B1+B2+B3+B4 mixture listing from an analog block
5	VCCA18	1V8A	analog 1V8
6	A	B1	PU - B1 input
7	GNDMN	GND A	analog gnd
8	B	B2	PU - B2 input
9	VCC33MN	3V3A	analog 3V3
10	REFD	to pick up	2V1 output for PU
11	VCC18MN	1V8A	analog 1V8
12	D	B4	PU - B4 input
13	VCCA18IS	1V8A	analog 1V8
14	C	B3	PU - B3 input
15	VCCA33IS	3V3A	analog 3V3
16	GND AIS	GND A	analog gnd
17	VCC33SD	3V3A	analog 3V3
18	VCC18SD	1V8A	analog 1V8
19	GNDSD	GND A	analog gnd
20	F	C	PU-3 beam C input
21	E	A	PU-3 beam A input
22	VSHIELDIS	GND A	analog gnd
23	VCC18ADC	1V8A	analog 1V8
24	GNDADC	GND A	analog gnd
25	VSHIELDADC	GND A	analog gnd
26	VCC33DAC	3V3A	analog 3V3
27	GND DAC	GND A	analog gnd
28	SPINDLE	560ohm(st2)	DAC current listing for stepper drive
29	SLEDGE	560ohm(st1)	DAC current listing for stepper drive
30	REFEXT	20K1%	Reference for DAC
31	REFGND	refext	analog gnd
32	REFDAC	560ohm1%	DAC reference
33	FACT	560ohm1%	DAC current listing for focus
34	TACT	560ohm1%	DAC current listing for tracking
35	VCC18DAC	1V8A	analog 1V8
36	PC0	FG	FG pulse input
37	PC1	PS	Driver control signal
38	PC2	tray SW1(open)	SW input for tray OPEN position
39	PC3	SB	Driver control signal
40	PC4	SLD position	Inside SW input

No.	PIN name	description	detail
41	VSS	GNDD	digital gnd
42	VDD33	3V3D	digital 3V3
43	PC5	780/X650	780nm/650nmLD change control signal
44	PC6	spinde PDM	Control PDM listing for spindle drive
45	PC7	opicgain	OEIC gain control signal
46	PD7	03PU/X02PU	Pull-up settlement
47	VSS	GNDD	digital gnd
48	VDD18	1V8D	digital 1V8
49	PD6	(debug)	test
50	PD5	(debug)	test
51	PD4	(DSPclk)	test
52	PD3	(DSPdata)	test
53	PD2	(DSPstrb1)	test
54	PD1	error monitor	Terminal for TRKG error monitor (30KHzLPF add need)
55	PD0	tray PDM drive	Control PDM signal for tray drive
56	VSS	GNDD	digital gnd
57	VDD33	3V3D	digital 3V3
58	OUT_ERR	RS_ERROR	BE DATA I/F
59	OUT_EVALID	RS_ERR_EN	BE DATA I/F
60	VSS	GNDD	digital gnd
61	OUT_CLK	RS_BCLK	BE DATA I/F
62	VDD18	1V8D	digital 1V8
63	OUT_DVALID	RS_DVALID	BE DATA I/F
64	OUT_DATA	RS_DATA	BE DATA I/F
65	OUT_SYNC	RS_ECCBST	BE DATA I/F
66	PE5	SCL(DMA)	FE routine download input
67	PE4	SDA(DMA)	FE routine download input
68	PE3	SCL	BE command I/F
69	PE2	SDA	BE command I/F
70	PE1	tray SW2(close)	SW input for tray CLOSE position
71	PE0	DXXINT	FE status propagation signal
72	VSS	GNDD	digital gnd
73	VDD33	3V3D	digital 3V3
74	PF1	10K-pullup	Built-in facility setting terminal
75	PF0	10K-pulldown	Built-in facility setting terminal
76	VSS	GNDD	digital gnd
77	VDD18	1V8D	digital 1V8
78	PG1	to EMULATOR	Built-in facility setting terminal
79	PG0	to EMULATOR	Built-in facility setting terminal
80	TEST	10K-pulldown	test

A

No.	PIN name	description	detail
81	RESET_N	RESET	RESET input
82	VSSADC	GNDA	analog gnd
83	VDD18ADC	1V8A	analog 1V8
84	GNDPLL	GNDA	analog gnd
85	PLLOFF	GNDA	analog gnd
86	FREOUT	20MXtal	SYSTEMCLK oscillating circuit
87	FREIN	20MXtal	SYSTEMCLK oscillating circuit
88	VCC18PLL	1V8A	analog 1V8
89	LD1	650nmLD	650nmLD driving signal
90	LD2	780nmLD	780nmLD driving signal
91	VCCA33	3V3A	digital 3V3
92	TWSEL	CD_VR/GND	Monitor diodes VR junction terminal for CD
93	LMD1	LMD/LMD1	Monitor voltage junction terminal
94	LMD2	DVD_VR/LMD2	Monitor diodes VR junction terminal for DVD
95	GNDL	GNDA	analog gnd
96	TST_PM	nc	test
97	TST_SLICE	nc	test
98	TST_ADC	nc	test
99	RFSACD	SACD_IC	RF signal output
100	VBGFILT	capacitor	Condenser junction terminal for inside reference stability

D

E

F

STI5588CVB (DVDM ASSY : IC601)

• BACK END IC

● Pin Configuration

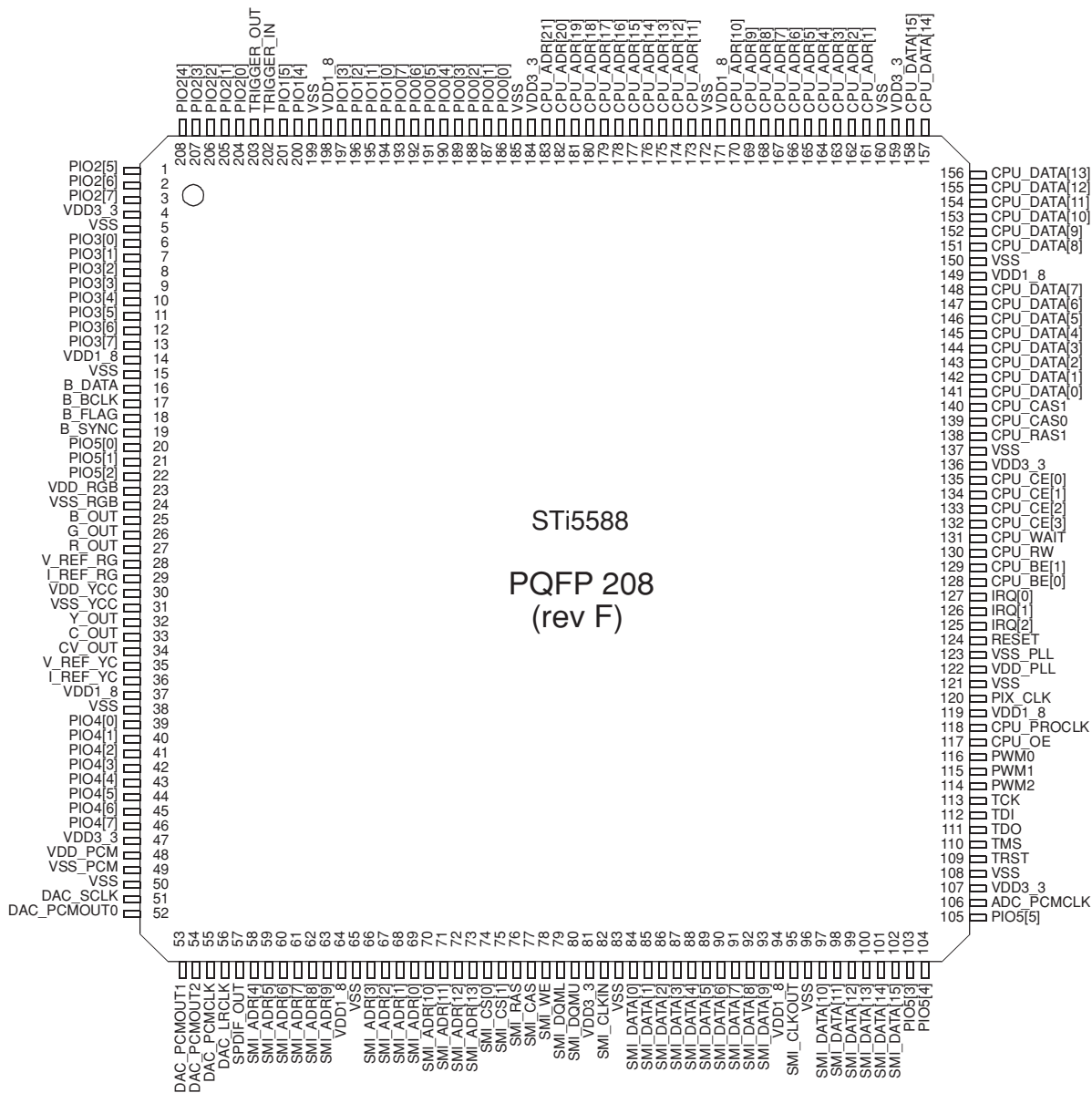

● Block Diagram

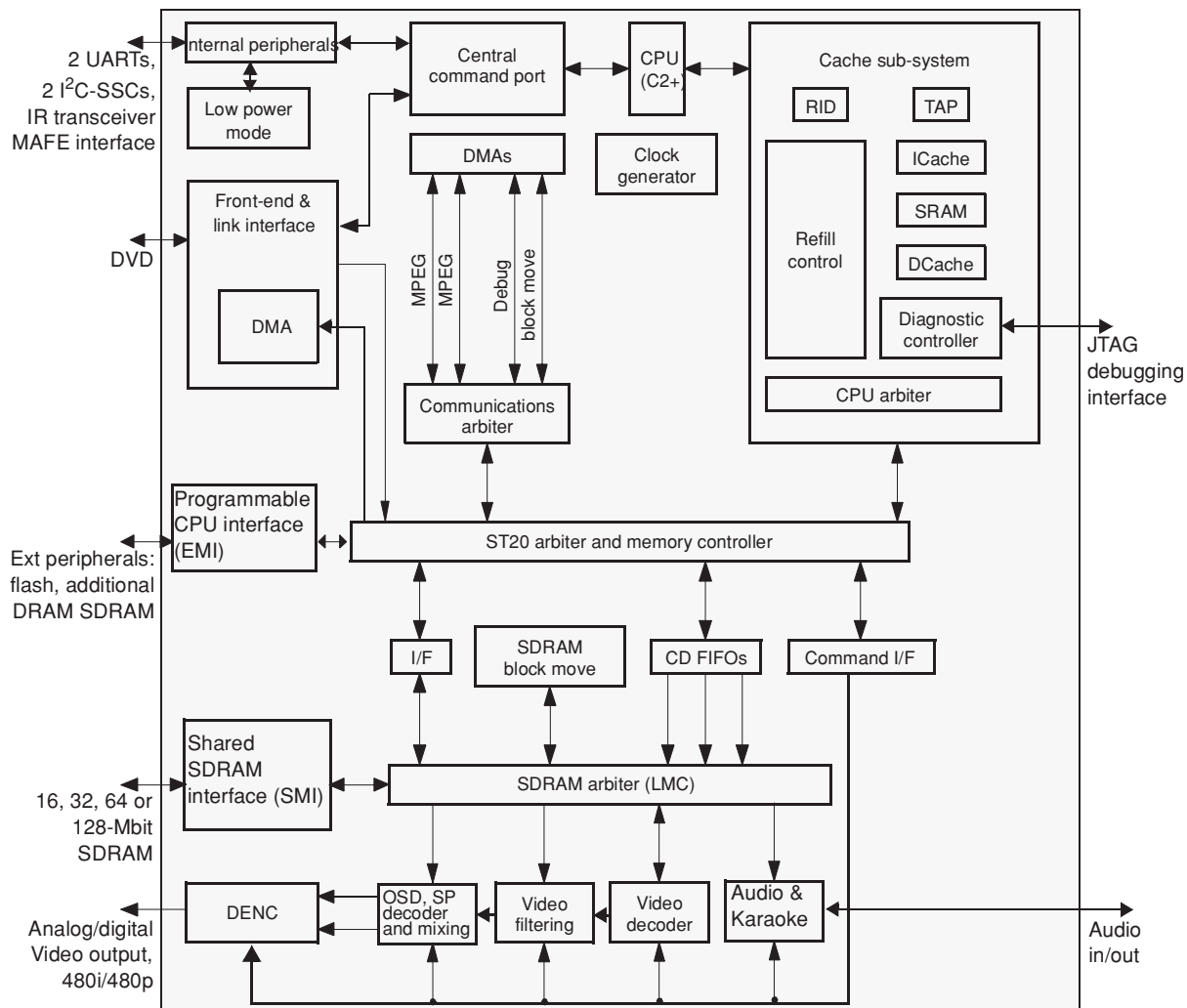

● Pin Function

No.	Pin Name	Dir.	Pin Function
1	FP_SO	OUT	Front Panel / DAC interface. Serial transfer data output.
2	A_DATA3	OUT	Data output to SACD decoder
3	VCLK	OUT	reserved
4	VDD_3V3	-	3.3 V Power supply
5	VSS	-	Ground
6	B_DATA	OUT	SACD data output to SACD decoder
7	B_BCLK	OUT	SACD bit clock output to SACD decoder
8	B_FLAG	OUT	SACD flag output to SACD decoder
9	TRYPOS	OUT	It is not connected except 5 Disc Changer.
		IN	Only 5 Disc Changer. Tray rotation pulse input. CAPTURE_IN0 can be used.
10	SQUEEZE	OUT	Output signal for S-Video output S1/S2 control. 'H' : squeeze output mode.
11	RTS	OUT	UART(RS-232C) Request To Send signal output.
12	LETTER	OUT	Output signal for S-Video output S1/S2 control & EURO(SCART) connector (FUNCTION SWITCHING) signal. 'H' : letter-box output mode.
13	CTS	IN	UART(RS-232C) Clear To Send signal input.
14	VDD_1V8	-	1.8 V Power supply
15	VSS	-	Ground
16	FE_DATA	IN	Front-End L6316 stream interface. Serial data input.
17	FE_BCLK	IN	Front-End L6316 stream interface. Serial clock input.
18	FE_DVALID	IN	Front-End L6316 stream interface. Data valid flag input.
19	FE_SYNC	IN	Front-End L6316 stream interface. Serial synchronize flag input.
20	FE_EVALID	IN	Front-End L6316 stream interface. Error valid flag for RS_split.
21	FE_ECCBST	IN	Front-End L6316 stream interface. ECC block start flag for RS_split.
22	I/XP	OUT	Output signal for a change of interlace/Progressive output for video driver. 'L' : progressive 'H' : interlace
23	VDD_RGB	-	RGB circuit 3.3 V Power supply
24	VSS_RGB	-	RGB circuit Ground
25	B_OUT	OUT	B / Cb
26	G_OUT	OUT	G / Y
27	R_OUT	OUT	R / Cr
28	VREF_RGB	IN	RGB DAC reference
29	IREF_RGB	IN	RGB DAC current reference
30	VDD_YCC	-	YC circuit 3.3 V Power supply
31	VSS_YCC	-	YC circuit Ground
32	Y_OUT	OUT	Y
33	C_OUT	OUT	C
34	CV_OUT	OUT	CV
35	VREF_YCC	IN	YCC DAC reference
36	IREF_YCC	IN	YCC DAC current reference
37	VDD_1V8	-	1.8 V Power supply
38	VSS	-	Ground

No.	Pin Name	Dir.	Pin Function
39	FE_XDRV_MUTE	OUT	It is not connected except 5 Disc Changer. Only 5 Disc Changer. Output signal for motor driver muting. 'L' : muting
		OUT	It is not connected except 5 Disc Changer.
40	FE_OPEN	IN	Only 5 Disc Changer. Input signal for tray position. 'H' : complete OPEN position.
		OUT	It is not connected except 5 Disc Changer.
41	FE_CLOSE	IN	Only 5 Disc Changer. Input signal for tray position. 'H' : complete CLOSE position.
		OUT	It is not connected except 5 Disc Changer.
42	CLAMP	IN	Only 5 Disc Changer. Input signal for showing disc clamp position. 'H' : complete disc clamp position.
		OUT	It is not connected except 5 Disc Changer.
43	XUNCLAMP	IN	Only 5 Disc Changer. Input signal for showing disc un-clamp position. 'H' : complete disc clamp position.
		OUT	It is not connected except 5 Disc Changer.
44	DISC_SNS	IN	Only 5 Disc Changer. Input signal for disc existing. 'L' : existing
		OUT	It is not connected except 5 Disc Changer.
45	XDRVMUTE2	OUT	reserved
46	TP-x	OUT	reserved
47	VDD_3V3	-	3.3 V Power supply
48	VDD_PCM	-	1.8 V Power supply
49	VSS_PCM	-	Ground
50	VSS	-	Ground
51	A_BCK	OUT	Audio DAC clock
52	A_DATA0	OUT	Audio DAC Front L,R data
53	A_DATA1	OUT	Audio DAC Center, LFE data
54	A_DATA2	OUT	Audio DAC Surround L, R data
55	A_MCLK	OUT	Audio DAC Master clock
56	A_LRCK	OUT	Audio DAC L/R clock
57	A_DOUT	OUT	S/PDIF(IEC60958) digital audio output.
58	SMI_A4	OUT	SMI SDRAM Address
59	SMI_A5		
60	SMI_A6		
61	SMI_A7		
62	SMI_A8		
63	SMI_A9		
64	VDD_1V8	-	1.8 V Power supply
65	VSS	-	Ground
66	SMI_A3	OUT	SMI SDRAM Address
67	SMI_A2		
68	SMI_A1		
69	SMI_A0		
70	SMI_A10		
71	SMI_A11		
72	SMI_A12		
73	SMI_A13		

No.	Pin Name	Dir.	Pin Function
74	SMI_CS0	OUT	SMI SDRAM chip select 'L'.
75	SMI_CS1	OUT	reserved
76	SMI_RAS	OUT	SMI SDRAM RAS 'L'
77	SMI_CAS	OUT	SMI SDRAM CAS 'L'
78	SMI_WE	OUT	SMI SDRAM Write Enable 'L'
79	SMI_DQML	OUT	SMI SDRAM Lower DQM 'L': Lower select
80	SMI_DQMU	OUT	SMI SDRAM Upper DQM 'L': Upper select
81	VDD_3V3	-	3.3 V Power supply
82	SMI_CLKIN	IN	External SDRAM clock input.
83	VSS	-	Ground
84	SMI_D0	I/O	SMI SDRAM Data
85	SMI_D1		
86	SMI_D2		
87	SMI_D3		
88	SMI_D4		
89	SMI_D5		
90	SMI_D6		
91	SMI_D7		
92	SMI_D8		
93	SMI_D9		
94	VDD_1V8	-	1.8 V Power supply
95	SMI_CLKOUT	OUT	SDRAM clock output.
96	VSS	-	Ground
97	SMI_D10	I/O	SMI SDRAM Data
98	SMI_D11		
99	SMI_D12		
100	SMI_D13		
101	SMI_D14		
102	SMI_D15		
103	TRACK_CROSS	OUT	reserved
104	DSD_XPCM	OUT	reserved
105	DAC_XRST	OUT	Reset signal of audio DAC. 'L': Reset
106	ADC_PCMCLK	OUT	reserved
107	VDD_3V3	-	3.3 V Power supply
108	VSS	-	Ground
109	XTRST	IN	Diagnostic Control Unit interface
110	TMS	IN	Diagnostic Control Unit interface
111	TDO	OUT	Diagnostic Control Unit interface
112	TDI	IN	Diagnostic Control Unit interface
113	TCK	IN	Diagnostic Control Unit interface
114	ROTDRV	OUT	Only 5 disc changer. PWM output for tray rotation.
115	BOOT_FROM_ROM	IN	Boot select 'L' : Boot from DCU. 'H' : Boot form ROM.
116	LOAD_DRV	OUT	Only 5 disc changer. PWM output for tray Open/Close drive.
117	CPU_OE	OUT	OE signal for 16M bits FLASH memory for firmware. 'L': enable

A

No.	Pin Name	Dir.	Pin Function
118	CPU_SDCK	OUT	CLOCK for 64M bits SDRAM for debugging firmware.
119	VDD_1V8	-	1.8 V Power supply
120	PIXCLK	IN	Master 27MHz system clock input.
121	VSS	-	Ground
122	VDD_PLL	-	Clock PLL circuit 1.8 V Power supply
123	VSS_PLL	-	Clock PLL circuit Ground
124	XRESET	IN	Power ON system RESET signal. 'L': reset
125	SACD_IRQ	IN	Interrupt signal from SACD decoder
126	FP_XRDY	IN	Front Panel interface. Hand-shake input.
127	FE_INT	IN	Interrupt input signal from Front-End L6316.
128	F_XWE, SD_DQML	OUT	Flash memory write enable. Debug SDRAM/SRAM Lower DQM. 'L': enable, Lower select.
129	SD_DQMU	OUT	Debug SDRAM/SRAM Upper DQM 'L':upper select
130	SD_RXW	OUT	Debug SDRAM Read/Write 'L':write, 'H':read
131	CPU_WAIT	IN	CPU wait 'H' input
132	CE_FLASH	OUT	Flash memory Chip Enable 'L'.
133	CE_SACD	OUT	Licence signal from SACD decoder
134	CPU_CE1	OUT	reserved
135	SD_XRAS	OUT	Debug SDRAM RAS 'L' Debug SRAM chip enable 'L'
136	VDD_3V3	-	3.3 V Power supply
137	VSS	-	Ground
138	CPU_RAS1	OUT	reserved
139	SD_XCAS	OUT	Debug SDRAM CAS 'L'
140	SD_XCS	OUT	Debug SDRAM Chip Select 'L'
141	CPU_D0	I/O	FLASH, Debug SDRAM/SRAM data
142	CPU_D1		
143	CPU_D2		
144	CPU_D3		
145	CPU_D4		
146	CPU_D5		
147	CPU_D6		
148	CPU_D7		
149	VDD_1V8	-	1.8 V Power supply
150	VSS	-	Ground
151	CPU_D8	I/O	FLASH, Debug SDRAM/SRAM data
152	CPU_D9		
153	CPU_D10		
154	CPU_D11		
155	CPU_D12		
156	CPU_D13		
157	CPU_D14		
158	CPU_D15		
159	VDD_3V3	-	3.3 V Power supply
160	VSS	-	Ground

F

No.	Pin Name	Dir.	Pin Function
161	CPU_A1	OUT	FLASH, Debug SDRAM/SRAM Address
162	CPU_A2		
163	CPU_A3		
164	CPU_A4		
165	CPU_A5		
166	CPU_A6		
167	CPU_A7		
168	CPU_A8		
169	CPU_A9		
170	CPU_A10		
171	VDD_1V8	-	1.8 V Power supply
172	VSS	-	Ground
173	CPU_A11	OUT	FLASH, Debug SDRAM/SRAM Address
174	CPU_A12		
175	CPU_A13		
176	CPU_A14		
177	CPU_A15		
178	CPU_A16		
179	CPU_A17		
180	CPU_A18		
181	CPU_A19		
182	CPU_A20		
183	CPU_A21		
184	VDD_3V3	-	3.3 V Power supply
185	VSS	-	Ground
186	XEXPE	OUT	reserved
187	FE_ERROR	IN	Front-End L6316 stream interface. ECC Error flag
188	VSEL1	OUT	EURO(SCART) connector (BLINKING) output signal 'L' : RGB output disable 'H' : RGB output enable
189	VSEL2	OUT	EURO(SCART) connector V/Y, R/C signal. 'L' : VRGB output = YCGB 'H' : VRGB output = VRGB
190	FE_RST	OUT	Front-End L6316. Hardware reset output. 'L' : reset
191	SACD_XRST	OUT	Reset signal of SACD decoder. 'L' : reset
192	XMMUTE	OUT	Output for tone quality enhancement
193	B_SYNC	OUT	Sector synchronization output to SACD decoder
194	SDA	I/O	Front-End L6316 command interface I2C bus serial data line.
195	SCL	OUT	Front-End L6316 command interface I2C bus serial clock line.
196	B_WCLK	OUT	Word clock output to SACD decoder
197	TXD	OUT	UART(RS-232C) data output
198	VDD_1V8		1.8 V Power supply
199	VSS	-	Ground
200	RXD	IN	UART(RS-232C) data input

A

No.	Pin Name	Dir.	Pin Function
201	XAMUTE	OUT	Output signal for analog audio output line muting. 'L' : muting
202	TRIGIN	IN	Diagnostic Control Unit interface
203	TRIGOUT	OUT	Diagnostic Control Unit interface
204	DAC_XCS0	OUT	Chip enable for audio DAC serial control. 'L' : enable
205	DAC_XCS1	OUT	Use of serial control of 5.1ch audio DAC is possible. 'L' : enable
206	FP_ACK	OUT	Front Panel / DAC interface. Hand-shake (acknowledge) output 'H'.
207	FP_SCK	OUT	Front Panel / DAC interface. Serial transfer clock output.
208	FP_SI	IN	Front Panel interface. Serial transfer data input.

B

C

D

E

F

M63018FP (DVDM ASSY : IC101)

• BTL Driver IC

● Pin Arrangement

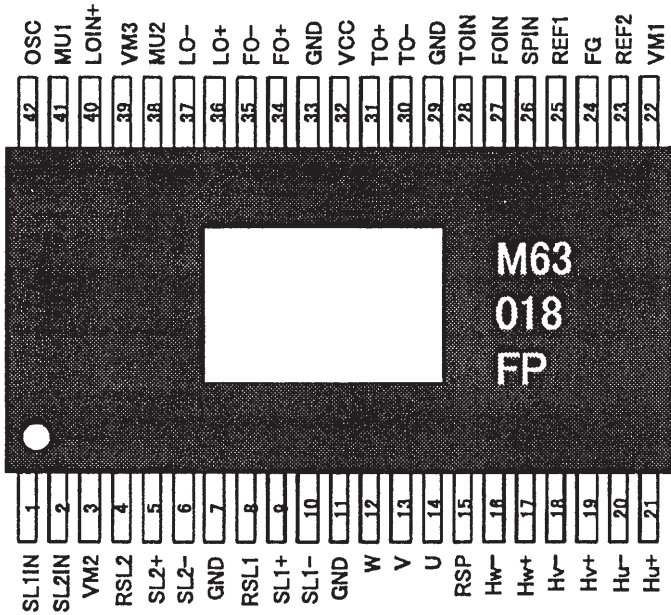

● Block Diagram

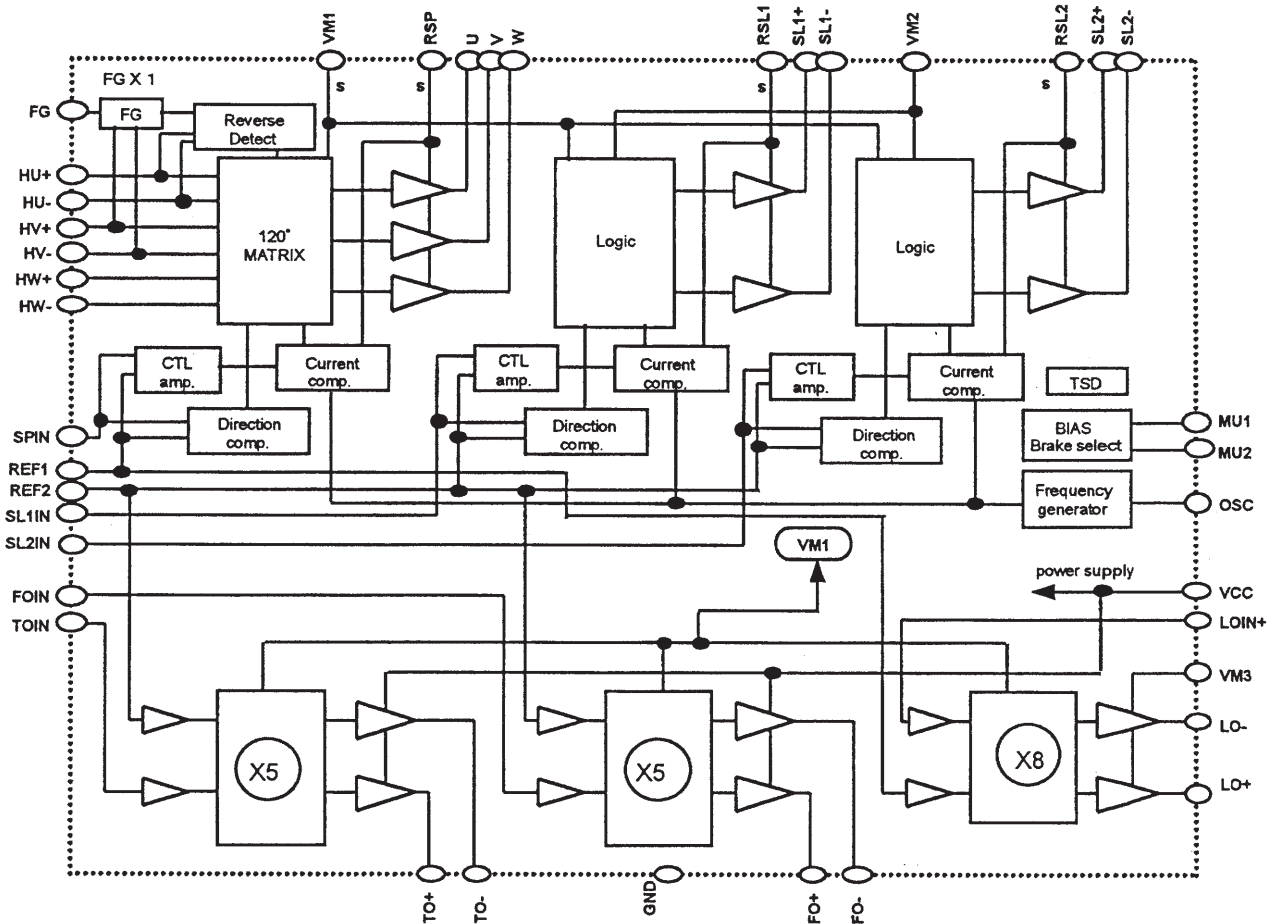

A

● Pin Function

TERMINAL	SYMBOL	TERMINAL FUNCTION	TERMINAL	SYMBOL	TERMINAL FUNCTION
1	SL1IN	Slide control voltage input 1	4 2	OSC	PWM carrier oscillation set
2	SL2IN	Slide control voltage input 2	4 1	MU1	mute / brake select terminal 1
3	VM2	Motor Power Supply 2 (for Slide)	4 0	LOIN+	Loading control input(+)
4	RSL2	Slide current sense 2	3 9	VM3	Power Supply3 (for Loading)
5	SL2+	Slide non-inverted output 2	3 8	MU2	mute / brake select terminal 2
6	SL2-	Slide inverted output 2	3 7	LO-	Loading inverted output
7	GND	GND	3 6	LO+	Loading non-inverted output
8	RSL1	Slide current sense 1	3 5	FO-	Focus inverted output
9	SL1+	Slide non-inverted output 1	3 4	FO+	Focus non-inverted output
1 0	SL1-	Slide inverted output 1	3 3	GND	GND
1 1	GND	GND	3 2	VCC	Power Supply (for FS ,TS)
1 2	W	Motor drive output W	3 1	TO+	Tracking non-inverted output
1 3	V	Motor drive output V	3 0	TO-	Tracking inverted output
1 4	U	Motor drive output U	2 9	GND	GND
1 5	RSP	Spindle current sense	2 8	TOIN	Tracking control voltage input
1 6	HW-	HW- sensor amp. input	2 7	FOIN	Focus control voltage input
1 7	HW+	HW+ sensor amp. input	2 6	SPIN	Spindle control voltage input
1 8	HV-	HV- sensor amp. input	2 5	REF1	Reference voltage input1 (for Spindle,Loading)
1 9	HV+	HV+ sensor amp. input	2 4	FG	Frequency generator output
2 0	HU-	HU- sensor amp. input	2 3	REF2	Reference voltage input2 (for Slide,Focus,Tracking)
2 1	HU+	HU+ sensor amp. input	2 2	VM1	Motor Power Supply 1 (for Spindle)

■ PE5374A (FLKY ASSY : IC101)

• FL Control IC

● Pin Function

No.	Pin Name	I/O	Function
1	VDD1	–	Positive Power Supply (3.3 V)
2	VSS1	–	Ground Potential
3	X1	IN	Crystal Connection for Main System Clock Oscillation
4	X2	–	
5	IC	–	Internally Connected (Directly connect to VSS1)
6	RESET	IN	Reset Input
7	SCK1	IN	Serial Clock Input of Serial Interface
8	SI1	IN	Serial Data Input of Serial Interface
9	SO1	OUT	Serial Data Output of Serial Interface
10	XRDY	OUT	Hand-shake (Ready) Output of Serial Interface
11	POWER ON	OUT	Power Control Output
12	RESET OUT	OUT	System Reset Output
13	RESERVE OUT	OUT	Reserved (NC on this model)
14	NC	OUT	NC
15	HALT	IN	Halt Port "NC" : Use Halt Mode
16	ACK	IN	Hand-shake (Acknowledge) Input of Serial Interface
17	SEL IR	IN	Remote Control Input (Timer input of 8-bit remote control timer)
18	AVSS	–	Ground Potential for A/D Converter
19	NC	IN	8 digit model(DV-260,263) : Key3 Input (Analog input for A/D converter)
20	KEY2	IN	Key Input 2 (Analog input for A/D converter)
21	KEY1	IN	Key Input 1 (Analog input for A/D converter)
22	KEY0	IN	Key Input 0 (Analog input for A/D converter)
23	VSS0	–	Ground Potential to Ports
24	AVDD	–	Analog Power/Reference Voltage Input to A/D Converter (3.3 V)
25	VDD0	–	Positive Power Supply to Ports (3.3 V)
26	MS0_2	IN	Model (of player) Select (Set with a combination of this 3 ports)
27	MS0_1	IN	
28	MS0_0	IN	
29	MS1_2	IN	Destination (of player) Select (Set with a combination of this 3 ports)
30	MS1_1	IN	
31	MS1_0	IN	
32	TES	IN	H" : No System Reset mode , "L" : General mode
33	OEM	IN	H" : OEM Model , "L" : Pioneer Model
34	MIC IN	IN	Detection of Microphone "H" : Microphone connected
35	CHECKER	IN	H" : Checker Mode "L" : General Mode
36	ON POWER	IN	H" : Primary Power Switch Model , "L" : Secondary Power Switch Model
37	FL SET2	IN	FL-Controller Mode Select FL SET1 / 2 = "L" / "L" : 8 digit model
38	FL SET1	IN	
39	TEST2	OUT	(Test Port)
40	STAND BY LED	OUT	Stand By LED Port

No.	Pin Name	I/O	Function
41	LED5	OUT	LED Port 5
42	LED4	OUT	LED Port 4
43	LED3	OUT	LED Port 3
44	LED2	OUT	LED Port 2
45	LED1	OUT	LED Port 1
46	LED0	OUT	LED Port 0
47	TEST1	OUT	(Test Port)
48	TEST0	OUT	(Test Port)
49	NC	OUT	NC
50	NC	OUT	NC
51	P16	OUT	FIP Segment 17 Output
52	P15	OUT	FIP Segment 16 Output
53	NC	OUT	FIP Segment 15 Output
54	P14	OUT	FIP Segment 14 Output
55	P13	OUT	FIP Segment 13 Output
56	P12	OUT	FIP Segment 12 Output
57	P11	OUT	FIP Segment 11 Output
58	P10	OUT	FIP Segment 10 Output
59	VDD2	-	Positive Power Supply to FIP Controller/Driver (3.3 V)
60	VLOAD	-	Pull-down Resistor Connection of FIP Controller/Driver (-28V)
61	P9	OUT	FIP Segment 9 Output
62	P8	OUT	FIP Segment 8 Output
63	P7	OUT	FIP Segment 7 Output
64	P6	OUT	FIP Segment 6 Output
65	P5	OUT	FIP Segment 5 Output
66	P4	OUT	FIP Segment 4 Output
67	P3	OUT	FIP Segment 3 Output
68	P2	OUT	FIP Segment 2 Output
69	P1	OUT	FIP Segment 1 Output
70	NC	OUT	FIP Grid 11 Output
71	NC	OUT	FIP Grid 10 Output
72	NC	OUT	FIP Grid 9 Output
73	G8	OUT	FIP Grid 8 Output
74	G7	OUT	FIP Grid 7 Output
75	G6	OUT	FIP Grid 6 Output
76	G5	OUT	FIP Grid 5 Output
77	G4	OUT	FIP Grid 4 Output
78	G3	OUT	FIP Grid 3 Output
79	G2	OUT	FIP Grid 2 Output
80	G1	OUT	FIP Grid 1 Output

7.3 DISC / CONTENT FORMAT PLAYBACK COMPATIBILITY

Disc / content format playback compatibility

General disc compatibility

This player was designed and engineered to be compatible with software bearing one or more of the following logos:



- KODAK Picture CD
-  is a trademark of Fuji Photo Film Co. Ltd.

Other formats, including but not limited to the following, are not playable in this player:

DVD-RAM / DVD-ROM / CD-ROM*

- * Except those that contain MP3 or JPEG. See also "Compressed audio compatibility" and "JPEG file compatibility" below.

DVD-R/RW and CD-R/RW discs (Audio CDs and Video CD/Super VCDs) recorded using a DVD recorder, CD recorder or personal computer may not be playable on this unit. This may be caused by a number of possibili-

ties, including but not limited to: the type of disc used; the type of recording; damage, dirt or condensation on either the disc or the player's pick-up lens. See below for notes about particular software and formats.

CD-R/RW compatibility

- This unit will play CD-R and CD-RW discs recorded in CD Audio or Video CD/Super VCD format, or as a CD-ROM containing MP3 or JPEG files. However, any other content may cause the disc not to play, or create noise/distortion in the output.
- This unit cannot record CD-R or CD-RW discs.
- Unfinalized CD-R/RW discs recorded as CD Audio can be played, but the full Table of Contents (playing time, etc.) will not be displayed.

DVD-R/RW compatibility

- This unit will play DVD-R/RW discs recorded using the DVD-Video format that have been finalized using a DVD-recorder.
- This unit will play DVD-RW discs recorded using the Video Recording (VR) format.
- **DVD-RW** shows in the display when a VR format DVD-RW disc is loading.
- When playing a VR format DVD-RW discs that was edited on a DVD recorder, the screen may go momentarily black at edited points and/or you may see scenes from immediately before the edited point.
- This unit cannot record DVD-R/RW discs.
- Unfinalized DVD-R/RW discs cannot be played in this player.

PC-created disc compatibility

- If you record a disc using a personal computer, even if it is recorded in a “compatible format” as listed above, there will be cases in which the disc may not be playable in this machine due to the setting of the application software used to create the disc. In these particular instances, check with the software publisher for more detailed information.
- Check the DVD-R/RW or CD-R/RW software disc boxes for additional compatibility information.

Compressed audio compatibility

- This unit will play CD-ROM, CD-R, and CD-RW discs containing files saved in the MPEG-1 Audio Layer 3 (MP3) format with a sampling rate of 32, 44.1 or 48kHz. Incompatible files will not play and the message **Can't play this format** will be displayed (**NO PLAY** in the front panel display).
- Fixed bit-rate MP3 files are recommended. Variable bit-rate (VBR) MP3 files are playable, but playing time may not be shown correctly..
- The CD-ROM used to compile your MP3 files must be ISO 9660 Level 1 or 2 compliant. CD physical format: Mode1, Mode2 XA Form1. Romeo and Joliet file systems are both compatible with this player.
- Use CD-R or CD-RW media for recording your files. The disc must be finalized (i.e. the session must be closed) in order to play in this unit. This player is not compatible with multi-session discs. Only the first session of a multi-session disc will be recognized.
- This player only plays tracks that are named with the file extension .mp3 or .MP3.

- When naming MP3 files, add the corresponding file name extension (.mp3). Files are played according to the file extension. To prevent noise and malfunctions, do not use these extensions for other kinds of files.
- This player can recognize up to 999 files (MP3/JPEG) and up to 499 folders. If a disc exceeds these limits, only files and folders up to these limits will be playable. Files and folders are read/displayed in alphabetical order. Note that if the file structure is very complex, you may not be able to read/play all files on the disc.
- Folder and track names (excluding the file extension) are displayed.
- There are many different recording bit-rates available to encode MP3 files. This unit was designed to be compatible with all of them. Audio encoded at 128Kbps should sound close to regular CD Audio quality. This player will play lower bit-rate files, but please note that the sound quality becomes noticeably worse at lower bit-rates.

JPEG file compatibility

- Baseline JPEG and EXIF 2.1* still image files up to 8 mega-pixels are supported (maximum vertical and horizontal resolution is 5120 pixels). (**File format used by digital still cameras*)
- The CD-ROM used to compile your JPEG files must be ISO 9660 Level 1 or 2 compliant. CD physical format: Mode1, Mode2 XA Form1. Romeo and Joliet file systems are both compatible with this player.
- This player only displays files that are named with the file extension .jpg or .JPG.

7.4 CLEANING



Before shipping out the product, be sure to clean the following positions by using the prescribed cleaning tools:

Position to be cleaned	Cleaning tools
Pickup lenses	Cleaning liquid : GEM1004 Cleaning paper : GED-008

A

B

C

D

E

F

8. PANEL FACILITIES

Front panel

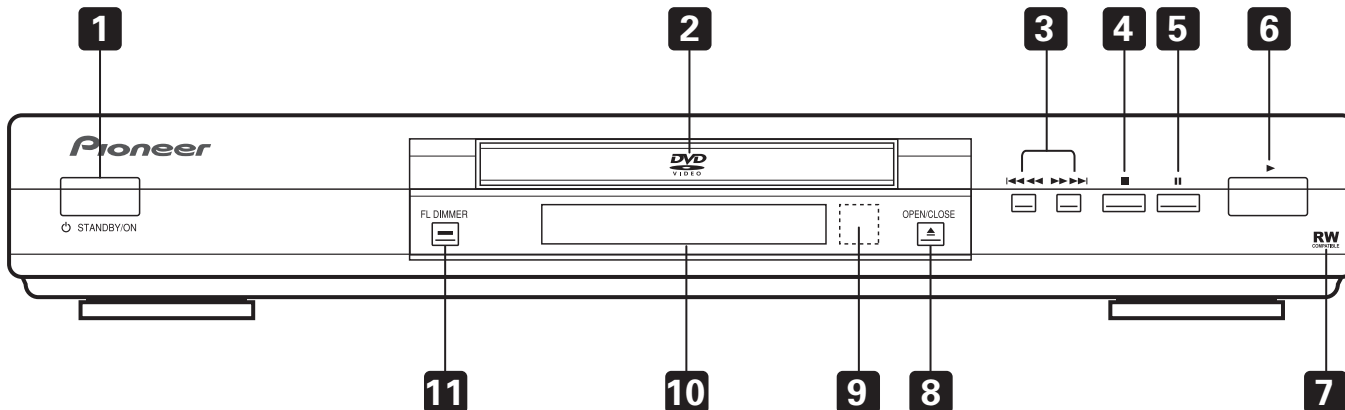

1 STANDBY/ON

Press to switch the player on or into standby.

2 **Disc tray**

3 and

- Press and hold for fast reverse/forward scanning.
- Press to jump to the previous/next chapter or track.

4

Press to stop the disc (you can resume playback by pressing (play)).

5

Press to pause playback. Press again to restart.

6

Press to start or resume playback.

7 **RW** COMPATIBLE

This mark indicates compatibility with DVD-RW discs recorded on a DVD recorder in Video Recording mode.

8 **OPEN/CLOSE**

Press to open or close the disc tray.

9 **Remote control sensor**

The remote control has a range of up to about 7m.

10 **Display**

11 **FL DIMMER**

Press to dim or brighten the display.

Rear panel connections

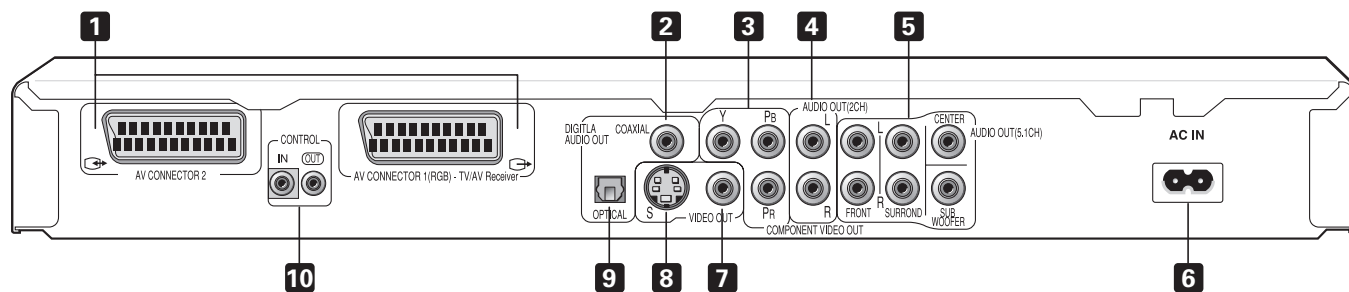

1 AV CONNECTOR

AV CONNECTOR 1 (RGB)-TV/AV Receiver

This is a combined audio and video output for connection to a TV that has a SCART input. Connect using a SCART cable. The type of video output can be switched to suit your TV.

AV CONNECTOR 2

Use a 21-pin SCART cable to connect to a VCR.

2 DIGITAL AUDIO OUT – COAXIAL

This is a digital audio output for connection to a PCM, Dolby Digital, DTS and/or MPEG-compatible AV receiver that has a coaxial digital input.

Connect using a commercially available coaxial digital audio cable.

3 COMPONENT VIDEO OUT

High quality video output for connection to a TV, monitor or AV receiver that has component video inputs.

Connect using a commercially available three-way component video cable. Be careful to match the colors of the jacks and cables for correct connection.

4 AUDIO OUT (2CH)

Two channel analog audio outputs for connection to your TV, AV receiver or stereo system.

Use the supplied audio/video cable when connecting these jacks. Match the colors of the jacks and cables for correct stereo sound.

5 AUDIO OUT (5.1CH)

Multichannel analog audio outputs for connection to an AV receiver with multichannel inputs.

6 AC IN

Connect the supplied power cord here, then plug into a power outlet.

7 VIDEO OUT

Standard video output that you can connect to your TV or AV receiver using the supplied audio/video cable.

8 S (S-Video output)

S-Video output that you can use instead of the video output described in **7** above.

9 DIGITAL AUDIO OUT – OPTICAL

This is a digital audio output for connection to a PCM, Dolby Digital, DTS and/or MPEG compatible AV receiver that has an optical digital input. Connect using a commercially available optical digital audio cable.

10 CONTROL IN / OUT

For passing remote control signals to other Pioneer components.

Display

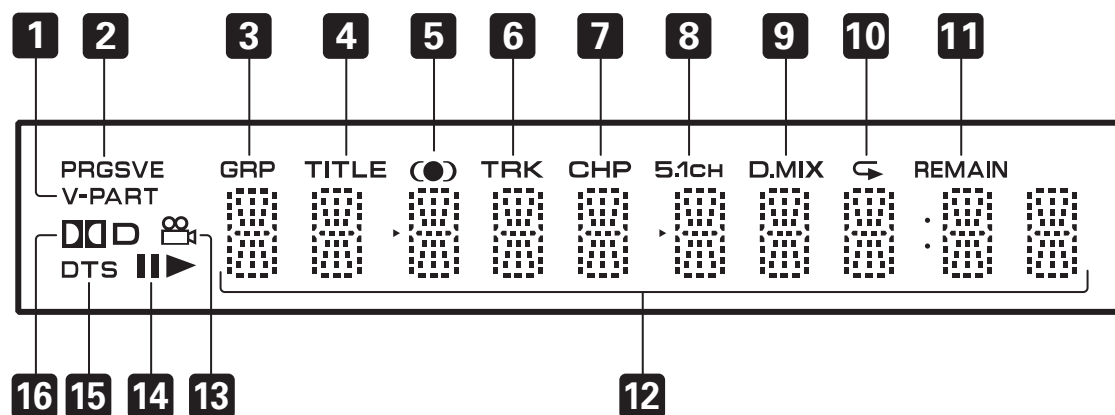

1 V-PART

Lights when playing a video part of a DVD disc.

2 PRGSVE

Lights when the player is set to output progressive scan video.

3 GRP

Indicates that the character display is showing a DVD-Audio group number.

4 TITLE

Indicates that the character display is showing a DVD title number.

5 (●)

Lights when DTS/SRS TruSurround is selected.

6 TRK

Indicates that the character display is showing a CD or Video CD/Super VCD track number.

7 CHP

Indicates that the character display is showing a DVD chapter number.

8 5.1CH

Lights when analog 5.1 channel output is selected.

9 D.MIX

During multichannel audio playback, indicates that the output signal has been "down-mixed" from the original audio source. This is an automatic function performed by the player in order to present the most appropriate audio mix to the speakers present in your system.

10 ↶

Lights in any of the repeat play modes.

11 REMAIN

Indicates that the character display is showing the disc or title/chapter/track remain time.

12 Character display

13 🎥

Lights during multi-angle scenes on a DVD disc.

14 || and ▶

Indicates whether a disc is playing or paused.

15 DTS

Lights when a DTS soundtrack is playing.

16 DD

Lights when a Dolby Digital soundtrack is playing.

Remote control

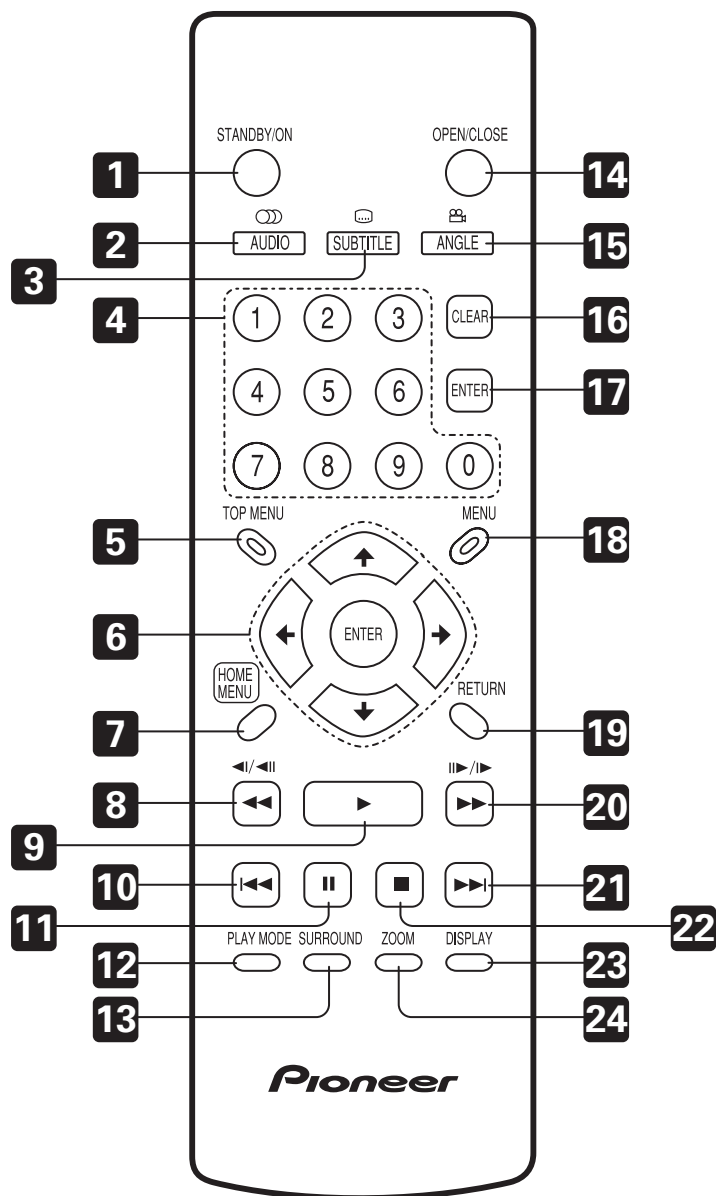

1 **STANDBY/ON**

Press to switch the player on or into standby.

2 **AUDIO**

Press to select the audio channel or language.

3 **SUBTITLE**

Press to select a subtitle display.

4 **Number buttons**

5 **TOP MENU**

Press to display the top menu of a DVD disc.

6 **ENTER & cursor buttons**

Use to navigate on-screen displays and menus. Press **ENTER** to select an option or execute a command.

7 **HOME MENU**

Press to display (or exit) the on-screen display.

8 **◀◀ and ◀/▶**

Use for reverse slow motion playback, frame reverse and reverse scanning.

9 **▶**

Press to start or resume playback.

10 **◀◀**

Press to jump to the beginning of the current chapter or track, then to previous chapters/tracks.

11 **||**

Press to pause playback; press again to restart.

12 PLAY MODE

Press to display the Play Mode menu. (You can also get to the Play Mode menu by pressing **HOME MENU** and selecting Play Mode).

13 SURROUND

Press to activate/switch off **DOLBY/SRS TruSurround**.

14 ▲ OPEN/CLOSE

Press to open or close the disc tray.

15 ANGLE

Press to change the camera angle during DVD multi-angle scene playback.

16 CLEAR

Press to clear a numeric entry.

17 ENTER

Use to select menu options, etc. (works exactly the same as the **ENTER** button in **6** above).

18 MENU

Press to display a DVD disc menu, or the Disc Navigator if a VR format DVD-RW, CD, Video CD/Super VCD, MP3 or JPEG disc is loaded.

19 RETURN

Press to return to a previous menu screen.

20 ►► and ►/||►

Use for forward slow motion playback, frame advance and forward scanning.

21 ►►|

Press to jump to the next chapter or track.

22 ■

Press to stop the disc (you can resume playback by pressing ► (play)).

23 DISPLAY

Press to display information about the disc playing.

24 ZOOM

Press to change the zoom level.