

PIONEER



Solid State AM/FM STEREO RECEIVER

Model **LX-880**

CAUTION Before connecting the line cord to the wall socket, carefully read and follow the instructions shown below, to assure the safety of your unit.

- Model LX-880 is set 240V operation when shipped. If this unit is used in a different line-voltage area, read and follow "LINE VOLTAGE SELECTION AND FUSE" on page 1.

Be sure that the line voltage setting on your unit agrees with the line voltage in your area and that the fuse installed in your unit is a proper one.

INSTALLATION, OPERATING AND SERVICE MANUAL

Including PARTS LIST, CIRCUIT DIAGRAMS AND TROUBLE SHOOTING

FVW



PIONEER ELECTRONIC CORPORATION

SOME UNIQUE FEATURES

- FM front-end employing a field effect transistor to hear more stations more clearly
- Integrated circuit (IC) employed in FM tuner assures outstanding capture ratio with high reliability
- Multiplex circuitry (MPX) for maximum channel separation
- Unique muting circuit permits the easiest tuning control
- High performance single ended push-pull (SEPP) output stage eliminates audio transformers and provides large output with true frequency fidelity
- Full complement input and output jacks and terminals

By the use of FET (field effect transistor) in the FM radio frequency amplifier stage, design of nearly perfect FM front-end was achieved—free from cross modulation, free from drift, with better sensitivity, lower inherent noise, and high spurious rejection ratio.

In the FM intermediate frequency amplifier stage, integrated circuits are employed, resulting in an entirely different outstanding performance from that of IF stages hitherto designed, especially in the limiter characteristic and the capture ratio.

The accurate electronic switching circuitry is employed in the FM multiplex demodulator, insuring maximum separation with excellent tonal quality.

The muting circuit provided in the FM tuner completely eliminates the FM inter-station noise which has hitherto been annoying the user in tuning.

The power-amplifier employs the high-performance single ended push-pull circuitry in the output stage and the push-pull complementary circuitry in the driver stage, completely eliminating the distortion inherent transformers from the audio stage. Transistors are adopted as the power transistors in the output stage for full-fidelity frequency response with large audio output power and least harmonic distortion.

For reproduction of various program sources, this receiver is provided with input jacks to be connected to a turntable equipped with a magnetic cartridge, a semiconductor cartridge or a ceramic cartridge as well as to microphones or a tape player (for monitoring). It is also provided with 2 pairs of speaker output terminals, headphone jacks and a tape recording jacks.

LOCATION FOR INSTALLATION OF MODEL LX-880

Your Model LX-880 is a solid-state unit. Determine location for installation of the unit with the following precautions in mind:

- The place where influence of dust and humidity is not significant and where good ventilation can be obtained.
- The place where the unit will not be exposed to the sun rays.

Note: Transistors get easily damaged by excessive heat. Take special care to ventilation of the unit. Placing things on the unit or installing the unit in recessed place will tend to excessively raise the internal temperature of the unit.

LINE VOLTAGE SELECTION AND FUSE

SWITCHING LINE VOLTAGE SETTING AND FUSE

In order to remove the fuse, turn the fuse cap located on the line voltage selector switch in the direction indicated by an arrow. Then remove the fuse plug from the unit. Put the fuse plug back so that the proper line voltage marking can be seen thru the cut in the edge of the plug. Whenever the set position of the selector switch is changed, check the rating of the fuse. A 0.5-ampere fuse is to be used for either 220V or 240V operation and a 1-ampere fuse for any of 110V, 117V, or 130V operation. If the rating of the fuse is proper, install the fuse on the fuse cap.

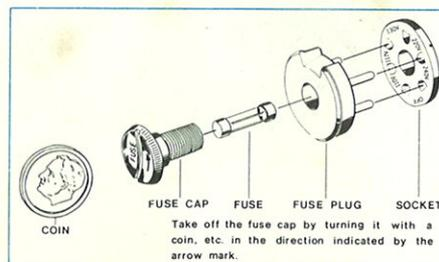
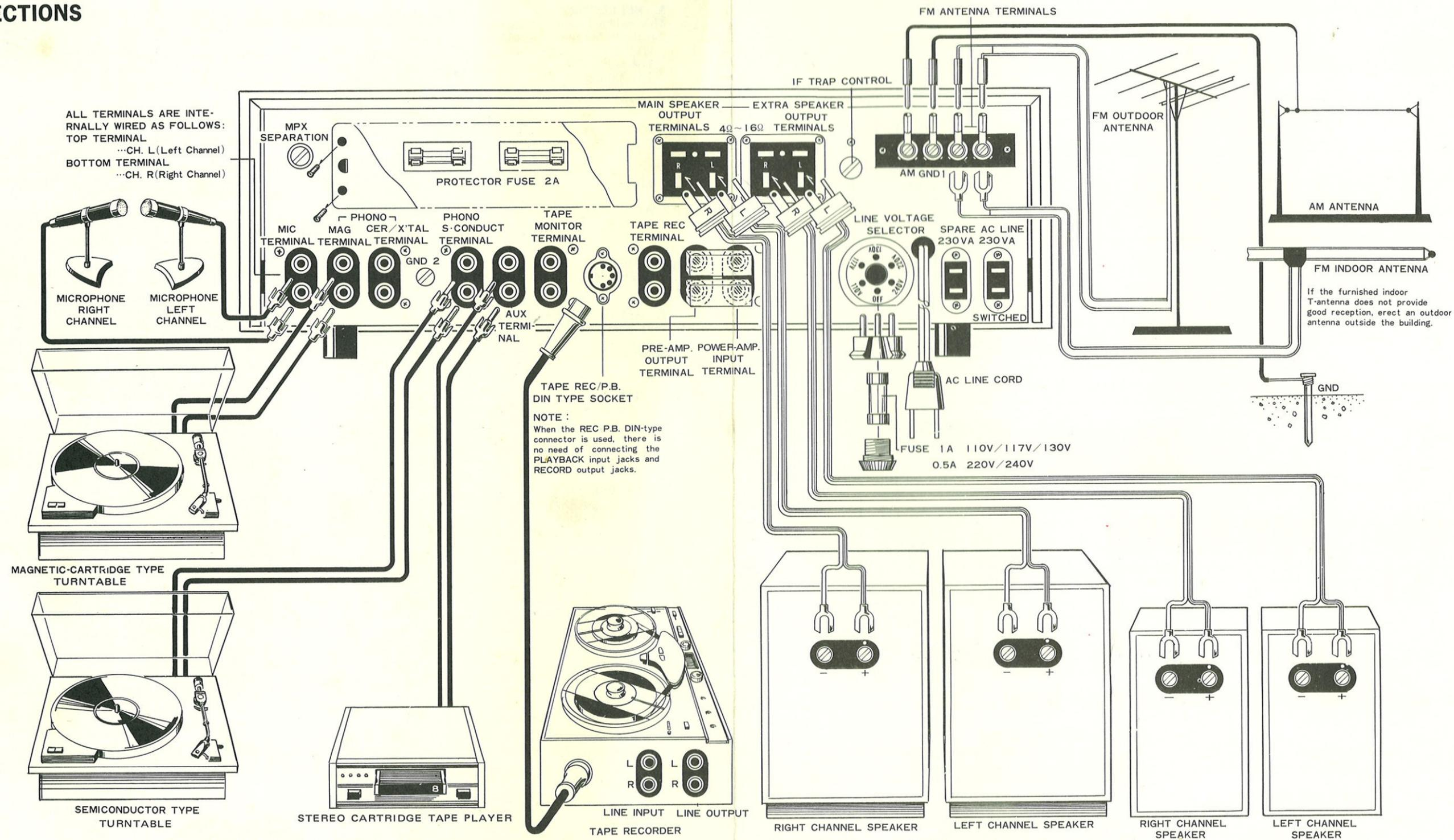

Fig. 1.

REPLACING OF FUSE

When the fuse is blown off, remove the fuse cap and replace the fuse with a new one.

CONNECTIONS



CAUTION:

1. If only one loudspeaker system is connected to either of the two sets of LOUDSPEAKER output terminals, the loudspeaker impedance each channel may be 4 to 16 ohms. If, however, both output terminals MAIN LOUDSPEAKER and EXTRA LOUDSPEAKER are used for connection with two loudspeaker system, the loudspeaker impedance each channel should be 8 to 16 ohms.
2. Never short the loudspeaker terminals.

Fig. 2

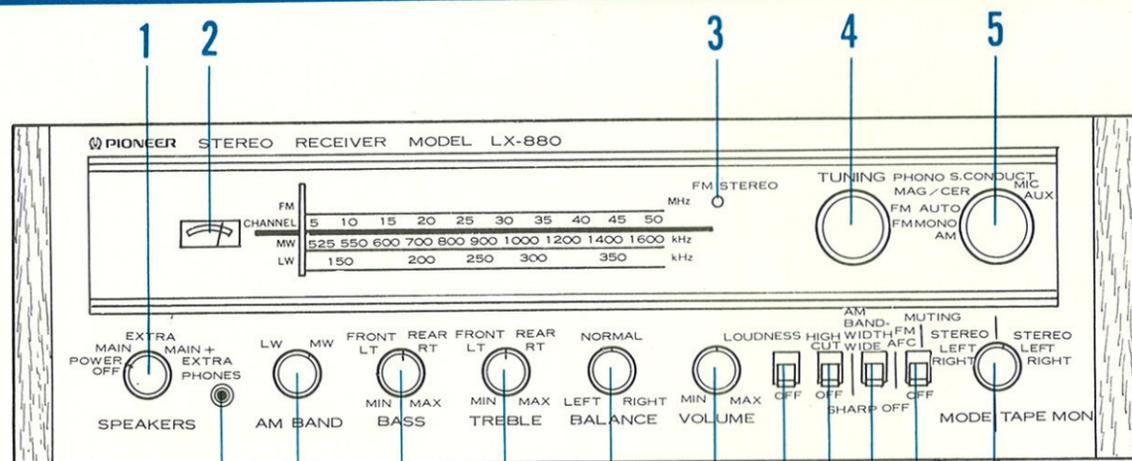

Fig. 3.

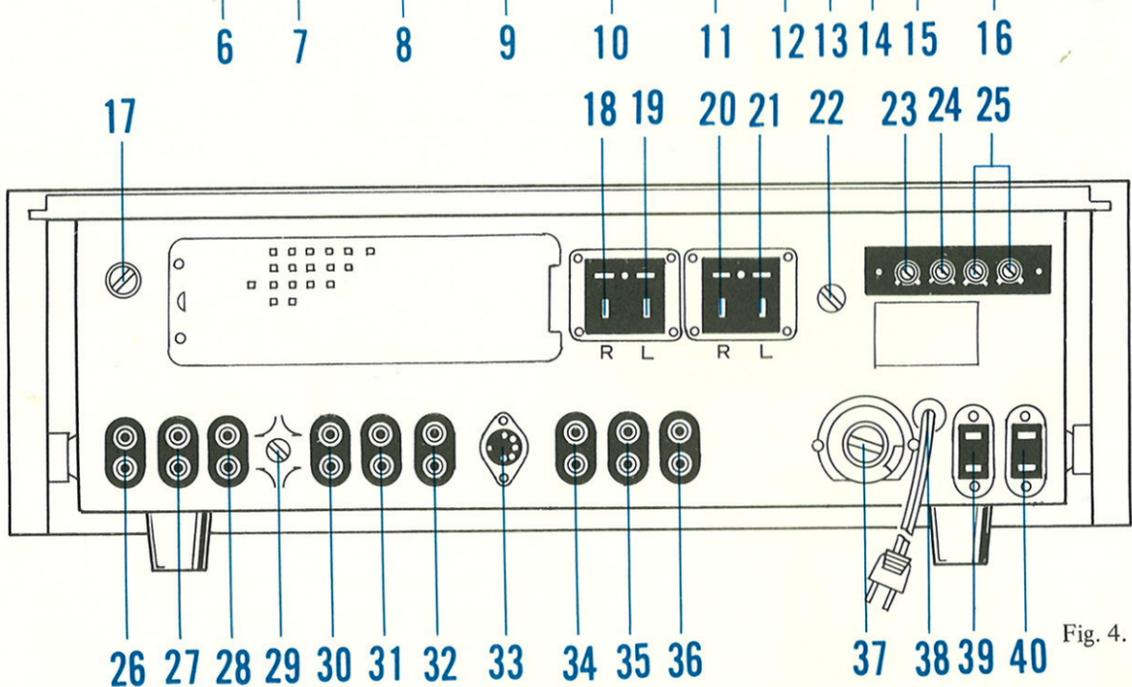

Fig. 4.

Functions of Controls and Switches on Front Panel

1. LOUDSPEAKERS

This switch selects the loudspeaker system to be used and also serves as the main power switch. Its positions are as follows:

- POWER OFF ...For turning the unit power off.
- MAINFor listening through MAIN loudspeakers.
- EXTRAFor listening through EXTRA loudspeakers.
- MAIN-EXTRA...For listening through both MAIN and EXTRA loudspeakers.
- PHONESFor muting all loudspeakers. (This function is convenient when the headphones are used.)

2. TUNING INDICATOR

This meter indicates the optimum tuning points for AM or FM stations. For tuning in a station, the TUNING control (4) is adjusted to produce maximum swing of this meter.

3. FM STEREO INDICATOR

This indicator light automatically switches on when the FM station is broadcasting stereo.

4. TUNING

This control tunes the receiver to the desired AM or FM station.

5. SELECTOR

This switch conditions the receiver to a variety of input signals: radio turntable and tape equipment.

- AMFor LW or MW reception
- FM-MONOFor FM-mono reception
- FM-AUTOFor FM Stereo/Mono automatic switching operation
- PHONO MAG/CERFor record playing with a turntable equipped with a magnetic or ceramic cartridge.
- PHONO S. CONDUCTFor record playing with a turntable equipped with a semi-conductor cartridge.
- MICFor reproducing direct inputs from a microphone
- AUXFor reproducing auxiliary inputs such as the audio signal from a TV set.

6. PHONES

This jack is for stereo headphones.

7. AM BAND SELECTOR

With the operation of this switch, LW (long wave) broadcast reception can be switched over to MW (medium wave) broadcast reception, or vice versa.

8. BASS

This control adjusts bass response. Turning it clockwise will boost, and turning it counterclockwise will reduce, bass response. The center top indicates the intermediate point.

9. TREBLE

This control adjusts treble response. Turning it clockwise will boost, and turning it counterclockwise will reduce, treble response. The center top indicates the intermediate point.

Note: These controls (BASS and TREBLE) are of two-section type; the front section adjusts the left channel and the rear section adjusts the right channel. Usually, the tone response is adjusted for both channels simultaneously. To adjust the response for only one channel, the section corresponding to the channel may be adjusted while the other is held by hand.

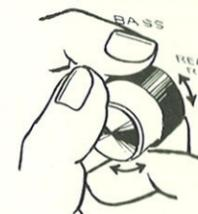

10. BALANCE

This control serves to balance the volume level of the left and right channels.

11. VOLUME

This control adjusts the volume level. Turning it clockwise will increase the volume, and turning it counterclockwise will decrease the volume.

12. LOUDNESS CONTOUR

For listening at low volume settings, this switch is set to the LOUDNESS position to increase the sounds in the extreme bass and treble range for adding reality to the reproduction. For listening at high volume level, this switch is normally set to OFF.

13. HIGH CUT FILTER

Setting this switch to the HIGH CUT FILTER position will eliminate high frequency noise, such as record scratch, hiss, static noise from fluorescent lamps, or other interference. When no such noise is present, this switch is normally set to OFF.

14. AM BAND WIDTH/FM AFC SWITCH

This switch serves as a band width switch for AM broadcast reception

SHARPSetting the switch to this position will eliminate interference noises, thus permitting a clear, noise-free reception of a broadcast.

WIDESetting the switch to this position permits a high fidelity reception of a broadcast. Be sure to set this switch for a reception of a long wave tele-diffusion.

This switch serves as a FM AFC switch for FM broadcast reception

This FM AFC switch is provided for listening to stabilized FM broadcast for long. Set the switch to OFF when tuning in a desired station, and then turn the switch to ON as soon as the desired station has been selected.

15. MUTING SWITCH

When an FM station is tuned in, setting this switch to MUTING will eliminate interference noises between FM stations. For reception of a weak-signal station, the switch should be set to OFF.

16. MODE/TAPE MON. SWITCH

This switch is the selector for stereo/mono and tape monitor settings. Its positions are as follows:

- MODE positions (for reproduction of records or reception of broadcasts)
 - STEREOFor reproduction of stereo program.
 - LEFTFor reproduction through both left and right channel loudspeakers of program material being fed to any of left channel inputs.
 - RIGHTFor reproduction through both left and right channel loudspeakers of program material being fed to any of right channel inputs.
- TAPE MON positions (for playback of tapes or for monitoring of tape being recorded)
 - STEREOFor stereo reproduction or stereo monitoring of recorded tapes.
 - LEFTFor mono reproduction of only left channel of recorded tape.
 - RIGHTFor mono reproduction of only right channel of recorded tape.



Functions of the rear panel controls, terminals and inputs

- 17. SEPARATION CONTROL**
This control adjusts the channel separation of FM multiplex stereo broadcasts. It has already been adjusted at the factory, and normally there should be no need for any further adjustment.
- 18. MAIN LOUDSPEAKER TERMINALS (RIGHT CHANNEL)**
The right channel main loudspeaker leads are connected to these terminals.
- 19. MAIN LOUDSPEAKER TERMINALS (LEFT CHANNEL)**
The left channel main loudspeaker leads are connected to these terminals.
- 20. EXTRA LOUDSPEAKER TERMINALS (RIGHT CHANNEL)**
The right channel extra loudspeaker leads are connected to these terminals.
- 21. EXTRA LOUDSPEAKER TERMINALS (LEFT CHANNEL)**
The left channel extra loudspeaker leads are connected to these terminals.
- 22. IF TRAP CONTROL**
This control is provided for eliminating beat interference (noise) in AM broadcast reception. It has been completely adjusted at the factory and there should be no need for any further adjustment.
- 23. AM ANTENNA TERMINAL**
This is the terminal for connection with the AM antenna (LW and MW broadcasts).
- 24. GND 1**
When using a ground lead for the receiver, it should be connected to this terminal.
- 25. FM ANTENNA TERMINALS**
These are the terminals for connection with the FM antenna.
- 26. MIC**
These jacks are for connecting a high impedance dynamic microphone.
- 27. PHONO MAG**
When using a turntable equipped with a magnetic cartridge, the output cables should be connected to these input jacks.
- 28. PHONO CER**
When using a turntable equipped with a ceramic or crystal cartridge, the output cables should be connected to these input jacks.
- 29. GND 2**
If a turntable equipped with a ground lead is used, the ground lead should also be connected to this terminal.
- 30. PHONO S. CONDUCT**
These jacks are for connecting a turntable equipped with a semiconductor cartridge. A turntable equipped with a MINI CONIC cartridge of Euphonic Co. can be directly connected to these input jacks.
Note: Don't connect a turntable equipped with a magnetic cartridge, a ceramic cartridge or a crystal cartridge.
- 31. AUX**
These are input jacks for auxiliary inputs such as the audio signal from a TV set.
- 32. TAPE MONITOR**
The outputs of the LINE OUTPUTS (the monitor output or playback output) of the tape recorder should be connected to these input jacks.
- 33. TAPE REC/P.B. CONNECTOR (DIN type)**
If your tape recorder is provided with the DIN-type record/playback connector and also you have a connecting cord with DIN-type connectors, the tape recorder can be connected with this unit for both recording and playback by simply connecting the cord between the recorder and this unit.
- 34. TAPE REC**
The LINE INPUTS (the inputs or AUX inputs for recording) of the tape recorder should be connected to these recording output jacks.
- 35. PRE-AMP OUTPUT 36. POWER-AMP INPUT**
These are output jacks of the pre-amplifier and input jacks of power amplifier respectively. These jacks are connected by a plug in a normal operation of this receiver. Each of these jacks can be used independently by removing the plug when PIONEER'S IS series (IS-70 or IS-80), or any other control amplifier or basic amplifier is connected to this receiver.
- 37. LINE VOLTAGE SELECTOR AND FUSE**
The line voltage selector and fuse are assembled into one unit. For instruction on change of line-voltage setting or on fuse replacement, see "LINE VOLTAGE SELECTION AND FUSE" on page 1.
- 38. LINE CORD**
This is the AC power cord. The AC plug provided at one end of this cord is inserted into the adjacent wall socket.
- 39. AC OUTLET**
This is an AC outlet that provides a convenient source of power for any associated equipment. It has a maximum capacity of 230 VA. This outlet is not controlled through the LOUDSPEAKERS switch (1) and remains live at all times.
- 40. AC OUTLET**
This is another AC outlet and has a maximum capacity of 230 VA.

Location for Installation of Loudspeakers

The best stereo-listening place is at the vertex (top) of an equilateral triangle having two stereo speakers at both ends of the base that is approximately 5 to 8 feet in length. If the flooring is made of hardwood or concrete,

lay soft carpet on it to prevent harmful echoes. Ideal location for installation of loudspeakers is such that hard wall stands behind the speakers, while soft curtain is hanging in the front.

Loudspeakers Connection

1. Connect the right channel speaker to the MAIN speaker terminal (18) and the left channel speaker to terminal (19).
2. The top terminal screw is for connection to the positive (+) side of the speaker voice coil, and the bottom

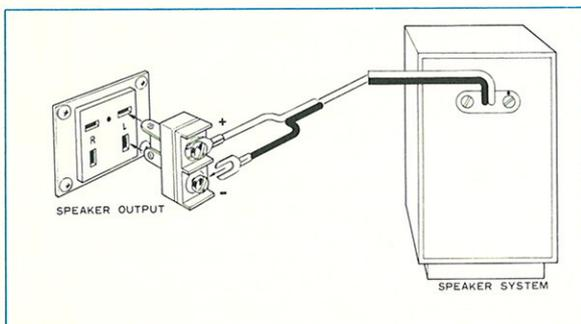

Fig. 5

terminal screw to the negative (-) side. Be sure that polarities are properly arranged in wiring without short-circuits.

For wiring two sets of stereo speakers (four speakers in total), follow the procedure shown below:

For wiring two sets of stereo speakers, the EXTRA speaker terminal will be used in addition to the MAIN terminal. After having connected one set of stereo speakers to terminals (18) and (19) as described above, connect the right channel speaker of the other set to terminal (20) and the left channel speaker to terminal (21).

Note: When two sets of stereo speakers are used, the impedance of each speaker voice coil must be somewhere between 8 to 16 ohms.

Antenna and Ground Connection

ANTENNA FOR RECEPTION OF AM (LW, MW) PROGRAMS

When your house is built with wooden materials and is located comparatively close to the transmitting station, lay the antenna wire furnished with the unit on the wall, connecting one end of the wire to the AM Antenna terminal (23).

When your house is made of ferro-concrete or is located far from the transmitting station, you may need to set up a separate AM antenna outdoors, connecting one end of the antenna lead to the AM Antenna terminal (23).

ANTENNA FOR RECEPTION OF FM AND FM STEREO PROGRAMS

If your house is built with wooden materials and is located close to the transmitting station, set up the indoor T-antenna in your room and connect the lead wire coming from the T-antenna to the FM antenna terminal (25). Appropriately adjust the direction and height of the T-antenna and fix it to a structure like wall. If your house is made of ferro-concrete or is located far from the transmitting station, you may need to set

up a separate FM antenna outdoors, because the arriving signals would be very weak. In this case, connect the FM antenna terminal (25) to the lead wire coming from the outdoor antenna.

GROUNDING

Connect the ground terminal (24) to the lead wire coming from a wall-grounded electrode.

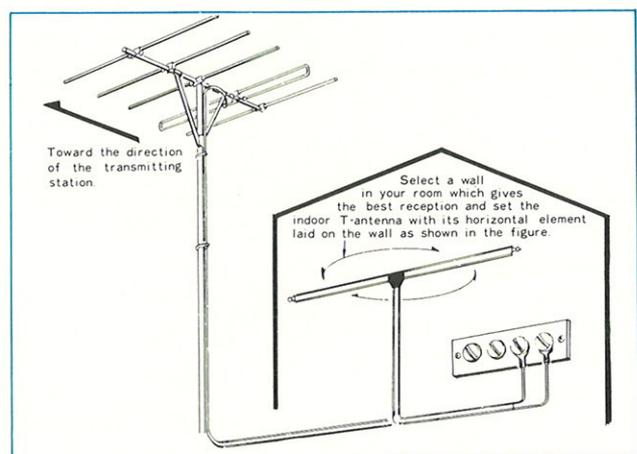

Fig. 6



Turtable Connection

MAGNETIC CARTRIDGE TYPE TURNTABLE

Connect a turntable equipped with a magnetic cartridge to PHONO MAG jack (27).

CERAMIC/CRYSTAL CARTRIDGE TYPE TURNTABLE

Connect a turntable equipped with a ceramic cartridge or a crystal cartridge to PHONO CER jack (28).

SEMICONDUCTOR CARTRIDGE TYPE TURNTABLE

Connect a turntable equipped with a semiconductor cartridge (MINI CONIC type) of Euphonic Co. to PHONO S. CONDUCT jack (30).

- NOTE: 1. The top jack is for the left channel use and the bottom jack is for the right channel use.
2. Connection to these jacks must be fast. Loose connection can be a cause of noises.

Tape Recorder Connection

CONNECTION FOR RECORDING

Connect the TAPE REC jack (34) to the LINE INPUT jack of the tape recorder. Note that the LX-800-T-W receiver's output signals are always appearing in this TAPE REC jack whenever the receiver is in operation.

The top jack is for the left channel use, and the bottom jack is for the right channel use. If the tape recorder is for monaural operation only, connect the tape recorder's LINE INPUT jack to either the top jack or the bottom jack.

VOLUME control (11), BASS & TREBLE controls (8) (9), and LOUDNESS CONTOUR (12) of Model LX-880 have no control over the signal coming out of this jack (34). The recording level must be adjusted on the tape recorder if required.

CONNECTION FOR TAPE PLAYBACK OR TAPE MONITORING

Connect the TAPE MONITOR jack (32) to the LINE OUTPUT jack of the tape recorder being used.

The top jack is for the left channel use, and the bottom jack is for the right channel use. If the tape recorder is for monaural operation only, connect the tape recorder's LINE OUTPUT jack to either the top jack or the bottom jack.

USE OF RECORD/PLAYBACK CONNECTOR SOCKET (DIN TYPE)

If your tape recorder is provided with a cord having DIN-type connector plug for recording & playback operation, connecting the plug to the record playback connector socket (33) will complete connection between the receiver and the tape recorder for both recording and playback operations.

Microphone Connection

When using a high-impedance dynamic microphone, connect it to MIC jack (26). The top jack is for the left channel use and the bottom jack is for the right channel use.

Tips on Operation

1. Short-circuits between speaker terminals will be fatal to transistors in the receiver. Prior to turning the unit power on, be sure that the speaker cords are properly connected.
2. Operating the SELECTOR switch (5) or the MODE/

TAPE MON switch (16) with the VOLUME control (11) turned all the way to the right (which means large volume) may cause a trouble in the unit. Avoid such a practice as applying large input abruptly to the unit.

Operations

TO LISTEN TO FM PROGRAMS

1. To listen to either FM monophonic program or FM stereophonic program, set the SELECTOR switch (5) to FM-AUTO and the MODE/TAPE MON switch (16) to MODE-STEREO.

Model LX-880 is provided with FM stereo/mono automatic switching circuit. Whenever the FM station changes its broadcast from monophonic program to stereophonic program, the Model LX-880 will automatically switch its reception accordingly and provides stereo audio output. Note that the stereo indicator will flash on when a stereophonic program is received.

2. Set the AFC switch (14) to OFF, and select the station you desire with the TUNING control (4), watching the TUNING meter (2).
3. When the station is properly tuned in, set the AFC switch to ON.

- Note:
1. When tuning in an FM station, set the MUTING Switch (15) to MUTING to reject inter-station noises. For receiving a very weak signal, set the switch to OFF.
 2. If the arriving stereo signal is weak and extraneous noise is significant while the SELECTOR switch (5) is set to FM-AUTO, the unit will automatically switch its reception to monophonic mode.
 3. If you desire to listen to a stereo program in monophonic mode for some reasons, or if the SELECTOR switch position in FM-AUTO causes the receiver to pick up noise excessively, set the SELECTOR switch to FM-MONO position. In this case, the MODE/MONITOR switch (16) may be in any position of MODE-STEREO, MODE-LEFT or MODE-RIGHT.

TO LISTEN TO AM (LW, MW) PROGRAMS

1. Set the SELECTOR Switch (5) to AM.
MODE/TAPE MON Switch (16) may be set to any of MODE-STEREO, MODE-LEFT or MODE-RIGHT.
2. Set AM BAND Switch (7) to LW for LW broadcast reception, and to MW for MW broadcast reception.
3. Select a desired station with TUNING Control (4).

TO PLAY A DISC RECORD

1. Set the SELECTOR Switch (5) to PHONO MAG/CER.
Be sure to set the SELECTOR (5) to PHONO S. CONDUCT when a turntable equipped with a semiconductor cartridge (MINI CONIC Type) of Euphonic Co.
2. Set the MODE/TAPE MON Switch (16) to MODE-STEREO.
When using a turntable for monophonic disc record, set the MODE/TAPE MON Switch (16) to either MODE-LEFT or MODE-RIGHT according to the channel (L or R) to which the player is connected.

WHEN MICROPHONE IS USED

1. Set the SELECTOR Switch (5) to MIC.
2. When using two microphones, set the MODE/TAPE MON Switch (16) to MODE-STEREO; when using only one microphone, set the MODE/TAPE MON switch to either MODE-LEFT or MODE-RIGHT according to the channel (L or R) to which the microphone is connected.



Record and Playback Operation with Tape Recorder, Using Model LX-880

TAPE RECORD

Set the SELECTOR switch (5) to any position of AM, FM-AUTO, or PHONO, depending on the source of signals to record.

- Note: 1. If you desire to make monophonic recording with either mono tape recorder or stereo tape recorder, connect the tape recorder to either the top (Left Channel) jack or the bottom (Right Channel) jack.
2. MODE/TAPE MON switch (16), VOLUME control (11), TREBLE control (9), BASS control (8), and HIGH CUT FILTER (13) have no control over the signals being recorded. The recording level must be appropriately adjusted on the tape recorder.

TAPE PLAYBACK

For stereo playback operation, set the MODE/TAPE MON switch (16) to MONITOR-STEREO position. If you desire to make monophonic playback with either stereo tape recorder or mono tape recorder, set the MODE/TAPE MON switch to either MONITOR-LEFT or MONITOR-RIGHT position, depending on the track on tape that you like to play back.

TAPE MONITORING

If your tape recorder (either two-head type or three-head type) is provided with monitor circuit and is connected to Model LX-880 for record and playback operations, you can make tape monitoring while the tape recorder is recording or playing back. Change the MODE/TAPE MON switch (16) position from MODE-STEREO to MONITOR STEREO. If your tape recorder is of two head type, you will monitor the signal before it enters the recording head. In case of three-head tape recorder, you will monitor the signal after it is recorded.

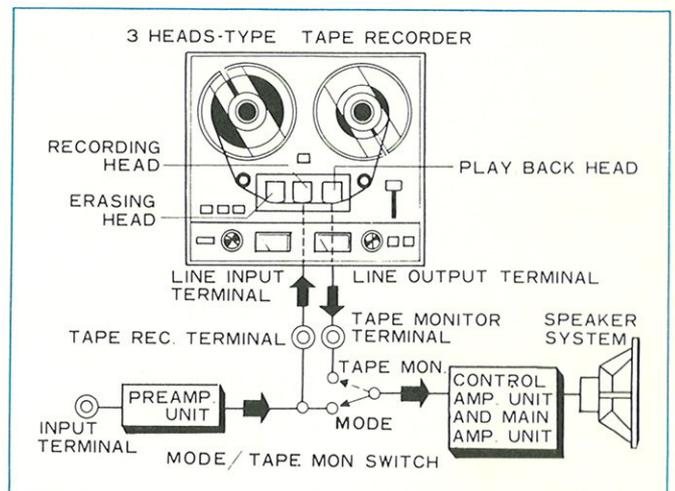

Fig. 7

CONDITIONS FREQUENTLY MISTAKEN FOR MALFUNCTION

Noise: There are a variety of noises relating to the operation of a hi-fi unit. These are generally divided into two types; (1) the unit is faulty (a transistor or part has deteriorated) and (2) an external source of noise is adding noise to the unit.

When a hi-fi unit produces an unpleasant noise, it is often assumed that the unit is faulty, but statistical records indicate that the majority of noises produced in hi-fi acoustic units result

from external sources of noise. Due to the inherent high sensitivity and the high fidelity in reproduction, the unit amplifies and reproduces extraneous noises, however small, into definite output noise. If your receiver produces a noise, check according to the following table and trace out the source of noise for the appropriate corrective action.

	Symptom	Suspected Source of Noise	Diagnosis and Remedy
When Listening to Broadcast	Continuous or intermittent noise like jjjjjj or zzzzzz.	<ul style="list-style-type: none"> • Static (lightning) • Fluorescent lamp, motor, or thermostat may be used in house or in the vicinity of the house. 	In many cases, it is very difficult to remove the source of noise. In order to make the radio input larger than the noise level, set up a good outdoor antenna and make a complete grounding.
	When a station is tuned in, hum is mixed in the program.	<ul style="list-style-type: none"> • Poor fluorescent lamp, motor, or electric heater may be used in house or near the house. 	Reversing the line plug may occasionally alleviate this noise problem. Usually it is very difficult to eliminate the noise.
	Hissing sound noise in AM (medium wave) reception.	<ul style="list-style-type: none"> • The frequency of an adjacent station is interfering with that of the station being tuned in (10kHz beat interference). • TV set is on in the same house with the receiver. 	Impossible to remove such interference. If the cause of such noise is in the TV set, increase the distance between the TV set and receiver.
	Static noise in FM reception (in particular, when automobiles run close to the house).	<ul style="list-style-type: none"> • White noises generated from automobile engines. • Radio frequency sewing machine or welding machine being used near your house. 	In an area surrounded by hills or high buildings, the FM input signals are very weak. Thus the noise limiter in the circuit loses its function. Set up an outdoor FM antenna having many reflector elements.
	Reception of FM stereo program contains more noise than FM mono program.	<ul style="list-style-type: none"> • Note that the service area covered by an FM stereo broadcast is about 50% of that of a regular mono broadcast. 	Increasing FM input signal may alleviate this problem. Use an exclusive FM outdoor antenna instead of the indoor T-antenna.
When Playing Records	Hum or buzz. When switched to radio reception, the noise will disappear.	<ul style="list-style-type: none"> • Poor connection of shielded wire. (a) • Jack connection is loose. (b) • Line cord or fluorescent lamp is near the shielded wire. (c) • Poor grounding. (d) • HAM transmitting station or TV transmitting station is near your house. (e) 	Correct the conditions stated in (a), (b), (c) or (d). In case of (e), report it to an official activity.
	Output tone quality is poor and mixed with noise. Treble is not clear.	<ul style="list-style-type: none"> • Stylus is worn out. (a) • Record is worn out. (b) • Dust adheres to stylus. (c) • Stylus is improperly mounted. (d) • Stylus pressure is not proper. (e) • The TREBLE sound level is too high. 	Check (a) through (e) and correct the condition. Lower the TREBLE level.

Further, watch the following conditions: these are also apt to be mistaken for malfunctions.

	Symptom	Suspected Source of Noise	Diagnosis and Remedy
	Power is not turned on although the power switch is set to ON.	<ul style="list-style-type: none"> • Fuse is blown. (a) • Line plug is loose. (b) 	Check (a) and (b) and correct the condition.
	In playing a record, increasing the volume causes howling.	<ul style="list-style-type: none"> • Distance between the turntable and the speakers is too short. • The place on which the turntable or speakers are set is unstable. 	Change the distance or rearrange the installation positions of the unit and speakers. (Installing the turntable on a firm, solid stand may alleviate this problem.) Do not enhance the BASS sound level excessively.



SPECIFICATIONS

TRANSISTORS AND DIODES

Tuner Section	
F.E.T.	1
I.C.s	4
Transistors	15
Diodes	17
Audio Section	
Transistors	23
Diodes and etc.	7

AUDIO SECTION

Circuitry	Single ended pushpull
Music Power	74 watts total/8Ω (IHF rating)
Output	90 watts total/4Ω
RMS Rated	28 watts per channel/8Ω
Power Output	35 watts per channel/4Ω
Harmonic Distortion	Less than 0.5% (at 1kHz rated output)
Frequency Response	±3dB, from 30Hz to 80kHz (Over-all)
Power Bandwidth	20Hz to 40 kHz (AUX)
Damping Factor	75 (at 1kHz)
Hum & Noise (at rated output)	MAG: better than 80dB AUX: better than 90dB
Inputs Impedance and Audio	MAGnetic PHONO: 2.4 mv. 50kΩ (1kHz)
Sensitivity (for rated output)	CERamic PHONO: 53 mv. 100kΩ (1kHz) SemiConductor PHONO: 5.3 mv. 1.2kΩ (1kHz)
	TAPE MONITOR: 210 mv. 100kΩ (1kHz)
	AUXiliary: 210 mv. 100kΩ (1kHz)
Output Terminals and Jacks	Speakers: 4~16 ohms Stereo headphones jack. Tape Recording jacks, equipped with TAPE MONITOR switch Tape recording/playback jack (DIN standards)
Equalization Curves	PHONO: RIAA TAPE: NAB
Tone Controls (each channel)	BASS: boost 11dB, cut 16dB (at 50Hz) TREBLE: boost 9.5dB, cut 9dB (at 10kHz)

Filter	HIGH: cut 6.5dB (at 10kHz)
Loudness Contour	Switchable to ON-OFF boost 13dB at 50Hz, boost 6.5dB at 10kHz, with VOLUME control set at -40 dB

FM SECTION

Circuitry	Front end using "F.E.T." and 4 gang variable capacitor, IF amplifier using 4 I.Cs
Frequency Range	87~108MHz
IHF Usable	2 μ v
Sensitivity	
Image Rejection	70dB (at 96MHz)
Capture Ratio	1dB (at 96MHz)
Signal to Noise Ratio	62dB (IHF rating)
Antenna Input	300 ohms (balanced)

MULTIPLEX SECTION

Circuitry	Time-switching type de-modulator FM Mono Stereo Automatic selection
Channel Separation	35dB (at 1kHz)

AM SECTION

Circuitry	Superheterodyne
Frequency Range	525~1605kHz (MW) 150~350 kHz (LW)
IHF Usable	28 μ v (MW)
Sensitivity	100 μ v (LW)
Image Rejection	50dB (at 1000kHz) 55dB (at 250kHz)

POWER SUPPLY

Line Requirements	110/117/130/220/240 volts, (switchable), 50-60Hz. 95 watts, 110VA (Max)
Dimensions	Overall 16 3/8" / 430mm (width) 5 11/16" / 144mm (height) 13 1/16" / 332mm (depth)
Weight	Net Net 20 lbs. 9.1kg Net 26 lbs. 11.8kg

These specification are subject to modification for improvement without notice.

ALIGNMENT INSTRUCTIONS

ALIGNMENT OF FM SECTION

Disconnect IF lead of Frontend unit from the IN terminal of IF unit

Position of Switch: SELECTOR FM MONO

AFC OFF

Volume Control Setting: Fully Counterclockwise

STEPS	Input			Dial Setting	Output Equipment Connections	Alignment	
	Equipment Connections	Frequency	Level			Adjust	Remarks
1	Sweep Generator IN	10.7MHz	40dB		Oscilloscope MET	T ₁ T ₂ T ₃	Adjust for maximum sensitivity and symmetrical characteristics
2			80dB				Check symmetry of characteristic curve
3	Remove electrolytic capacitor C ₁₉ (5μF) from detector circuit						
4	Sweep Generator IN	10.7MHz	40dB		Oscilloscope OUT	T ₄	Adjust the primary core of T ₄ so that slope of straight portion of "S" curve will become the steepest and adjust the secondary core so that the center of "S" curve will coincide with the center of the marker
5	Connect IF terminal of Frontend unit to IN terminal of IF unit						
6	Sweep Generator TP of Frontend	10.7MHz		Point of no interference as near as 88MHz	Oscilloscope MET	T ₂ of F.E. T ₁ T ₂ T ₃	Adjust for maximum sensitivity and symmetrical characteristics
7			80dB				Check symmetry of characteristic curve
8			40dB				T ₄
9	Connect electrolytic capacitor C ₁₉ (5μF) back to where it was						
10	Signal Generator FM Antenna terminal	90MHz	20dB (400Hz, 30%)	90MHz	VTVM Oscilloscope OUT	L ₅ (Front end)	Adjust for maximum deflection
11		106MHz		106MHz		CT ₄ (Front end)	
12	Repeat STEPS 10 and 11 several times						
13	Signal Generator FM Antenna terminal	90MHz	20dB (400Hz, 30%)	90MHz	VTVM Oscilloscope OUT	T ₁ L ₁ L ₂ (Front end)	Adjust for maximum deflection
14		106MHz		106MHz		CT ₁ , CT ₂ CT ₃ (Front end)	
15	Repeat STEPS 13 and 14 several times						



ALIGNMENT OF FM MPX SECTION

Position of Switch: SELECTOR FM AUTO
 AFC OFF, MUTING OFF
 Volume Control Setting: Fully Counterclockwise
 Input Signal: Main (L—R) 40.5kHz Deviation (60%)
 19kHz Pilot 7.5kHz Deviation (10%)

STEPS	Circuit to be adjusted	Input		Connect VTVM	Alignment	
		Connections	Signal		Adjust	Remarks
1	19kHz Trap	Oscillator to IN	19kHz 38mV	AC VTVM ②	T ₅	Adjust for minimum deflection
2	19kHz and 38kHz stage	MPX Generator to FM Antenna terminal	L—R	OUT L or R	T ₂	Adjust for maximum deflection
3	Separation Control		L or R	OUT R or L	VR ₅	Adjust for minimum deflection of the other channel
4			L+R	OUT L and R	VR ₁	Adjust for less than 2dB in the difference of out put
5	Repeat STEPS 3 and 4 several times					
6	Stereo Indicator light		Pilot		T ₁ T ₃	Adjust for maximum deflection
7			Main 15dB		VR ₂	Adjust to light stereo indicator lamp when MPX signal is applied

ALIGNMENT OF AM SECTION

Position of Switch: SELECTOR AM
 AM Band Width Sharp
 Volume Control Setting: Fully Counterclockwise

STEPS	Input			Dial Setting	AM BAND Selector Position	Output Equipment Connection	Alignment	
	Equipment Coupling	Frequency	Level				Adjust	Remarks
1	Sweep Generator IN	472kHz	40dB	Point of no interference as near as 1,605kHz	MW	VTVM Oscilloscope OUT	T ₃ T ₄ T ₅	Adjust for maximum sensitivity and symmetrical characteristics
2	Signal Generator Antenna Terminal through dummy	160kHz	(400Hz, 30%)	160kHz	LW		T ₁ ANT. Coil	Adjust for maximum deflection
3		340kHz		340kHz			C ₂₆ CT ₁	
4	Repeat STEPS 2 and 3 several times							
5		600kHz	74dB (400Hz, 30%)	600kHz	MW		T ₂	
6		1,400kHz		1,400kHz			C ₂₆	
7	Repeat STEPS 5 and 6 several times							
8		600kHz	40dB	600kHz			T ₂	
9		1,400kHz		1,400kHz			CT ₂	
10	Repeat STEPS 8 and 9 several times							
11		472kHz	80dB	1,400kHz			IF Trap Coil	Adjust for minimum deflection

DIAL CORD STRINGING

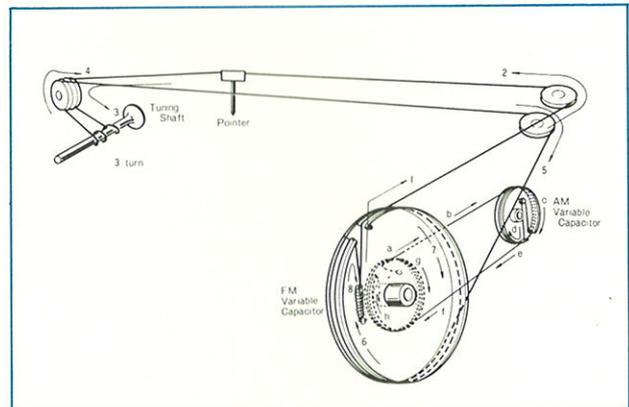

PART LAYOUT

Top View

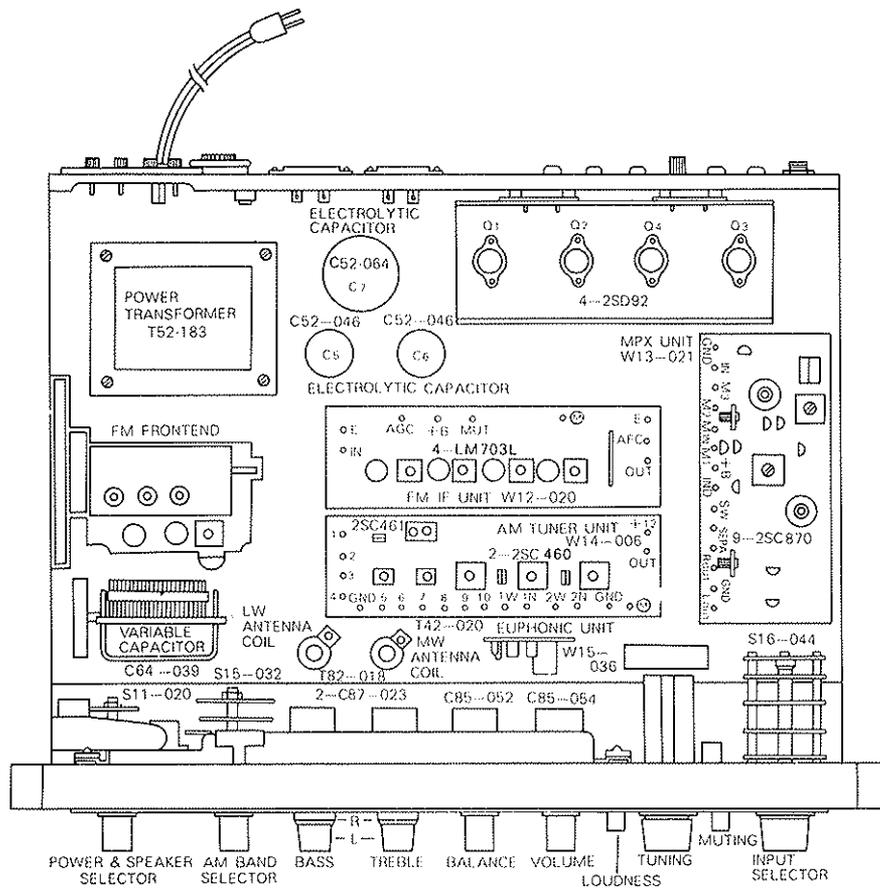

Bottom View

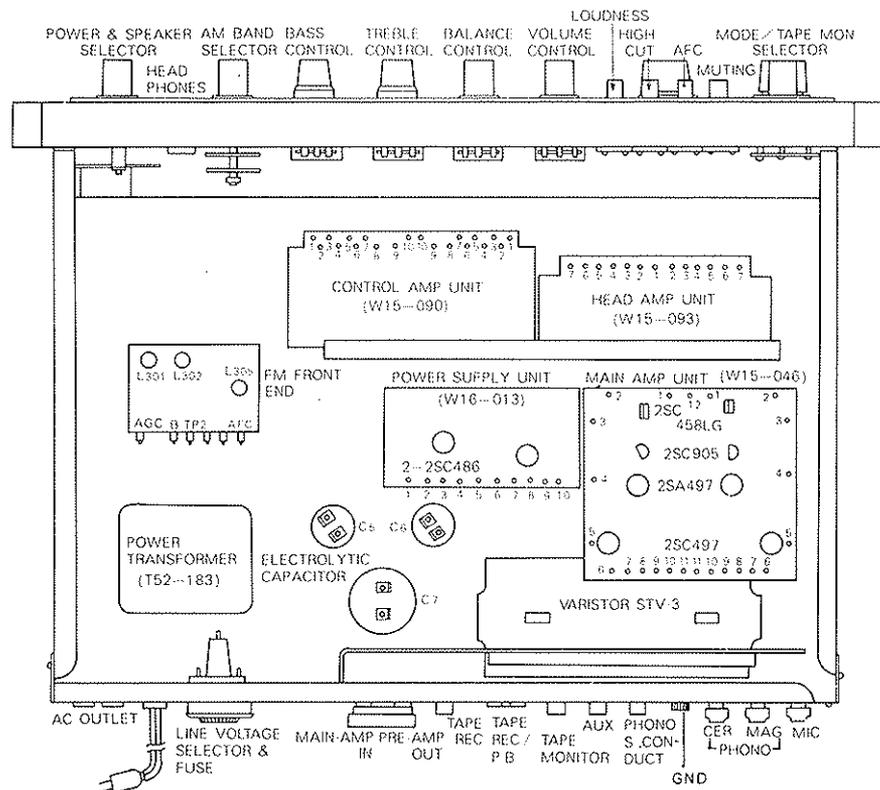

HEAD AMP UNIT (W15-093)

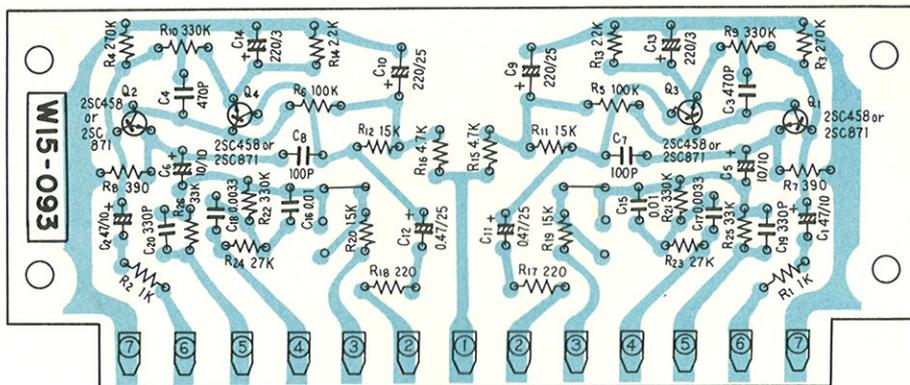

CONTROL AMP UNIT (W15-090)

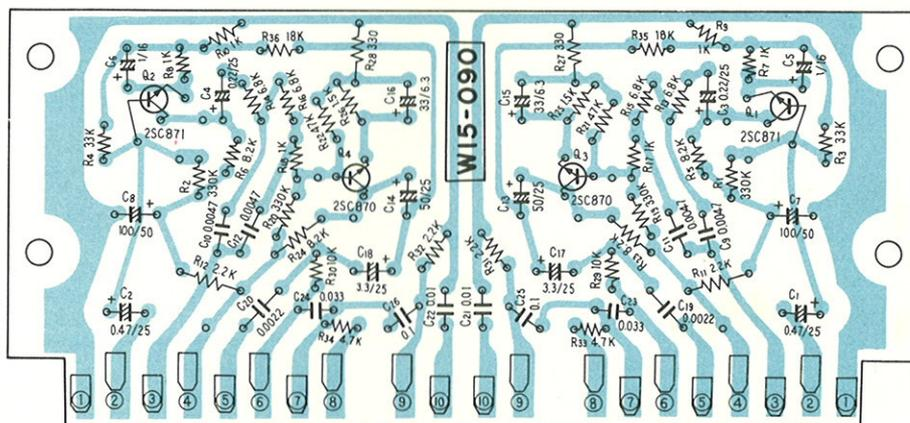

MAIN AMP UNIT (W15-046)

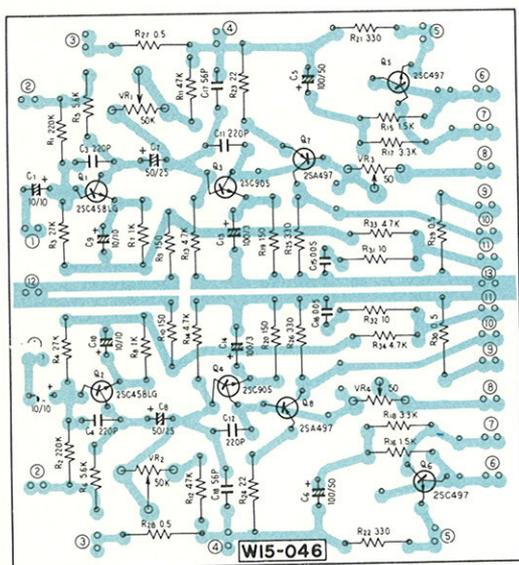

EUPHONIC UNIT (W15-036)

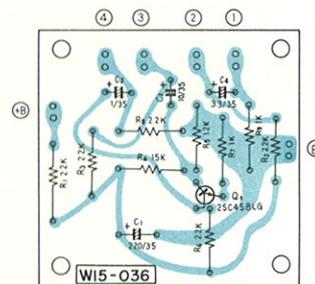

POWER SUPPLY UNIT (W16-013)

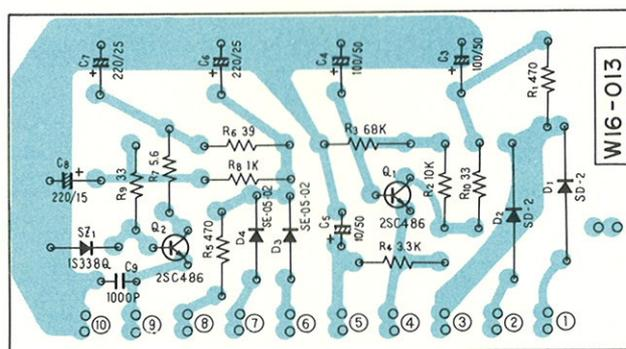

AM TUNER UNIT (W14-010)

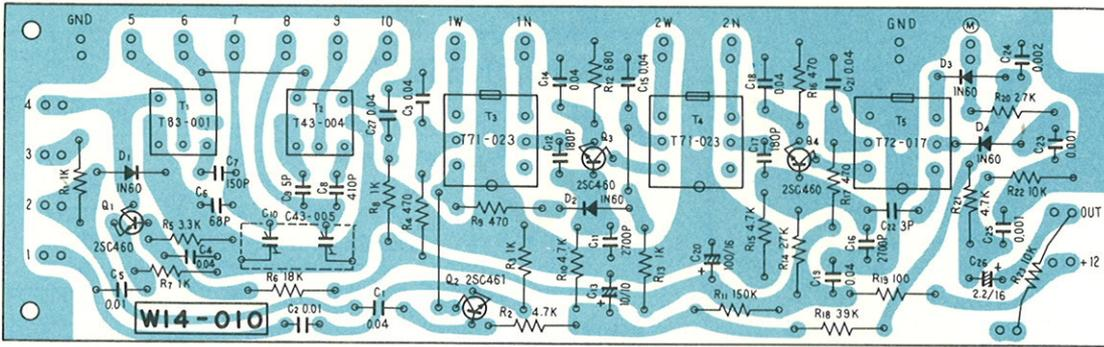

FM IF UNIT (W12-020)

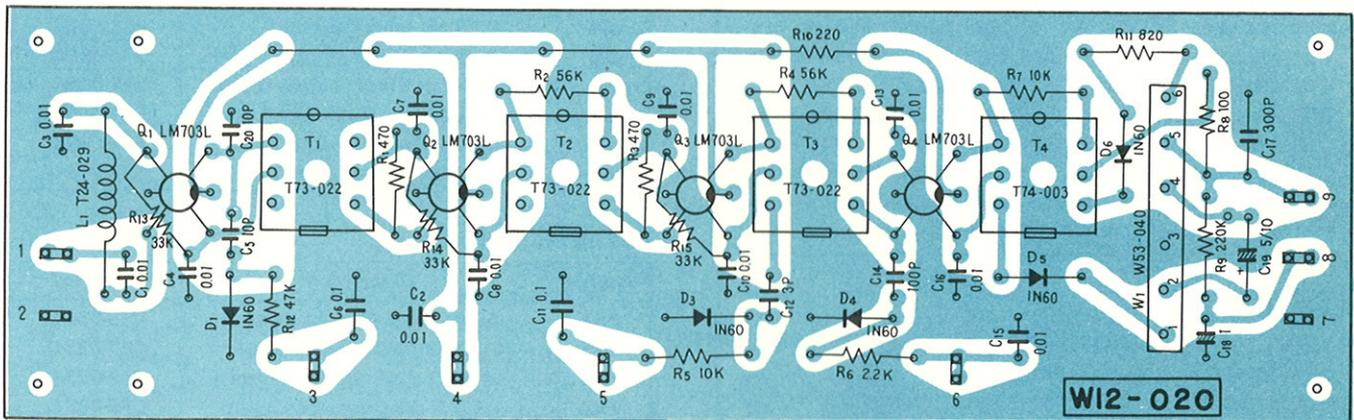

MPX UNIT (AWD-001)

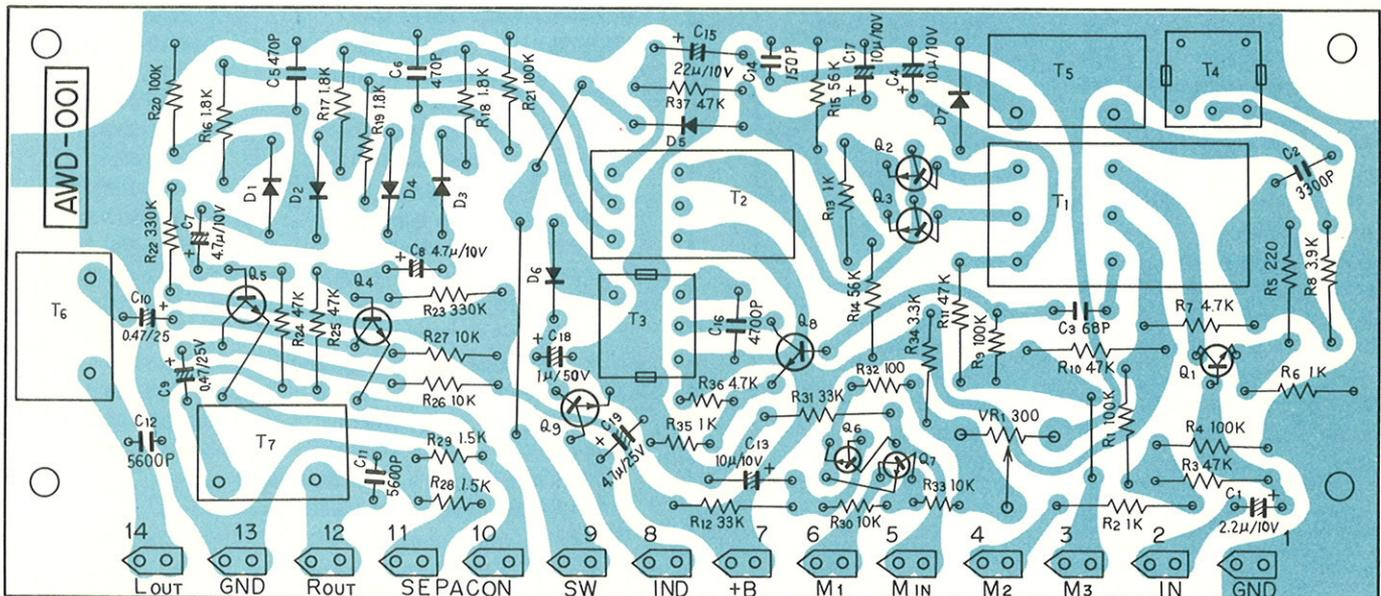

PARTS LIST

CAPACITORS

IN μF , 10% TOLERANCE UNLESS OTHERWISE NOTED

p: $\mu\text{M}\text{F}$

Symbol	Description			Part No.
C1	Ceramic	82p	50V	CCDSL 820K 50
C2	Ceramic	82p	50V	CCDSL 820K 50
C3	Mylar	0.01	50V	CQMA 103K 50
C4	Mylar	0.01	50V	CQMA 103K 50
C5	Electrolytic	1000	35V	C15-046-0
C6	Electrolytic	1000	35V	C15-046-0
C7	Electrolytic	2200	63V	C52-064-0
C8	Ceramic	0.01 $\begin{smallmatrix} +100\% \\ -0 \end{smallmatrix}$	50V	CKDYZ 103P 50
C9	Ceramic	0.01 $\begin{smallmatrix} +100\% \\ -0 \end{smallmatrix}$	500V	CKDYZ 103P 500
C10	Ceramic	0.01 $\begin{smallmatrix} +80\% \\ -20 \end{smallmatrix}$		C43-003-0
C11	Ceramic	0.01 $\begin{smallmatrix} +80\% \\ -20 \end{smallmatrix}$		C43-003-0
C12	Ceramic	0.01 $\begin{smallmatrix} +80\% \\ -20 \end{smallmatrix}$		C43-003-0
C13	Ceramic	5p	50V	CDSL 050K 50
C14	Ceramic	39p	50V	CCDSL 390K 50
C15	Electrolytic	470	16V	CETG 470MF 16V
C16	Styrol	0.001	50V	CQSA 102K 50
C17	Ceramic	0.001	50V	CKD Z5P 102K 50
C18	Ceramic	0.001	50V	CKD Z5P 102K 50
C21	Electrolytic	220	3V	CEMX 470MF 3V
C22	Ceramic	3p $\pm 0.5\text{p}$	50V	CCDSL 030D 50
VC1	AM Tuning Capacitor			C64-039-0

RESISTORS

IN OHM, 10% TOLERANCE $\frac{1}{4}\text{W}$ UNLESS OTHERWISE NOTED

k: K Ω , M: M Ω , LN: Low Noise

Symbol	Description			Part No.
R1	Carbon film (LN)	1M		RF $\frac{1}{4}$ PS 1M-K, NL
R2	Carbon film (LN)	1M		RF $\frac{1}{4}$ PS 1M-K, NL
R3	Carbon film (LN)	100k		RF $\frac{1}{4}$ PS 100K-K, NL
R4	Carbon film (LN)	100k		RF $\frac{1}{4}$ PS 100K-K, NL
R5	Carbon film (LN)	68k		RF $\frac{1}{4}$ PS 68K-K, NL
R6	Carbon film (LN)	68k		RF $\frac{1}{4}$ PS 68K-K, NL
R7	Carbon film (LN)	82k		RF $\frac{1}{4}$ PS 82K-K, NL
R8	Carbon film (LN)	82k		RF $\frac{1}{4}$ PS 82K-K, NL
R9	Carbon film (LN)	150k		RF $\frac{1}{4}$ PS 150K-K, NL
R10	Carbon film (LN)	150k		RF $\frac{1}{4}$ PS 150K-K, NL
R11	Carbon film (LN)	27k		RF $\frac{1}{4}$ PS 27K-K, NL
R12	Carbon film (LN)	27k		RF $\frac{1}{4}$ PS 27K-K, NL
R13	Carbon film (LN)	150k		RF $\frac{1}{4}$ PS 150K-K, NL
R14	Carbon film (LN)	150k		RF $\frac{1}{4}$ PS 150K-K, NL
R15	Wire wound	150	2W	RM 2P 150-K
R16	Wire wound	150	2W	RM 2P 150-K
R17	Carbon film	10		RF $\frac{1}{4}$ PS 10-K
R21	Carbon film	33k		RF $\frac{1}{4}$ PS 33K-K
R22	Carbon film	33k		RF $\frac{1}{4}$ PS 33K-K
R23	Carbon film	470k		RF $\frac{1}{4}$ PS 470K-K
R25	Carbon film	470		RF $\frac{1}{4}$ PS 470-K
R26	Carbon film	470		RF $\frac{1}{4}$ PS 470-K

DIODES AND TRANSISTORS

Symbol	Description	Part No.
D1	STV-3 Varistor	
D2	STV-3 Varistor	

Q1	2SD92 Transistor	
Q2	2SD92 Transistor	
Q3	2SD92 Transistor	
Q4	2SD92 Transistor	

COILS AND TRANSFORMER

Symbol	Description	Part No.
L1	MW Antenna Coil	T42-020-A
	LW Antenna Coil	T82-018-A
	IF Trap Coil	T71-022-0
	Heater Choke Coil	T42-025-A
	Power Transformer	T52-183-0

SWITCHES

Symbol	Description	Part No.
S1	Input Selector	S16-044-A
S2	Mode Selector	S16-038-C
S3	AM Band Selector	S15-032-0
S4	Speaker Selector	S11-020-0
S5	Loudness Switch (Toggle Type)	S42-002-B
S6	High Cut Filter (Toggle Type)	S42-002-B
S7	AM Band Width (Toggle Type)	S42-009-0
S8	Muting Switch (Toggle Type)	S42-002-B
S9	Line Voltage Selector	S11-018-0

POTENTIOMETERS

Symbol	Description	Part No.
VR1	500k Ω dual, Volume Control	C85-054-0
VR2	100k Ω dual, Bass Control	C87-023-0
VR3	100k Ω dual, Treble Control	C87-023-0
VR4	50k Ω dual, Balance Control	C85-052-0
VR5	10k Ω , MPX Separation Control	C92-028-0

MISCELLANEOUS

Symbol	Description	Part No.
	FM Front-end	W11-028-D
	FM IF Unit	W12-020-D
	MPX Unit	W13-021-F
	AM Tuner Unit	W14-010-0
	Euphonic Unit	W15-036-0
	Head Amp Unit	W15-093-0
	Control Amp Unit	W15-090-0
	Main Amp Unit	W15-046-0
	Power Supply Unit	W16-013-0
	Front Panel	M21-360-0
	Wooden Case	M52-128-0
	Dial Glass	A33-111-0
	Dial Pointer	A31-093-0
	Dial Pulley (for Tuning Capacitor)	M42-027-C
	Dial Pulley	M42-009-A
	Knob, Selector	A12-198-0
	Knob, Tuning	A12-014-A
	Knob, Volume, Balance, Mode, Speaker Selector, AM Band Selector	A12-144-D
	Knob, Bass, Treble (L)	A12-168-B
	Knob, Bass, Treble (R)	A13-016-B
	Tuning Meter	A91-009-B
	Pilot Lamp for Dial Glass	E22-017-0

Pilot Lamp for Tuning Meter	E22-002-0
Pilot Lamp for FM Stereo Indicator	E22-015-B
Pilot Lamp Socket	K42-003-A
Pilot Lamp Socket	K91-005-A
Less for FM Stereo Indicator	A59-036-0
Fuse 2A	E21-005-0
Fuse 1A	E21-004-0
Fuse 0.5A	E21-007-0
Headphone Jack	K72-026-0
Connector 5P	K93-003-B
Spare AC Outlet	K82-012-0
Speaker Plug	K72-007-B
Terminal 6P	K22-013-C
Terminal 4P	K11-018-0
Foot	M61-017-0

FM IF UNIT (W12-020)

CAPACITORS

Symbol	Description				Part No.
C1	Ceramic	0.01	+100% -0	25V	CKDYZ 103P 25
C2	Ceramic	0.01	+100% -0	25V	CKDYZ 103P 25
C3	Ceramic	0.01	+100% -0	25V	CKDYZ 103P 25
C4	Ceramic	0.01	+100% -0	25V	CKDYZ 103P 25
C5	Ceramic	10p		50V	CCDSL 100K 50
C6	Mylar	0.1	± 20%	50V	CQMA 104M 50
C7	Ceramic	0.01	+100% -0	25V	CKDYZ 103P 25
C8	Ceramic	0.01	+100% -0	25V	CKDYZ 103P 25
C9	Ceramic	0.01	+100% -0	25V	CKDYZ 103P 25
C10	Ceramic	0.01	+100% -0	25V	CKDYZ 103P 25
C11	Mylar	0.1	± 20%	50V	CQMA 104M 50
C12	Ceramic	3p	± 0.25p	50V	CCDSL 030C 50
C13	Ceramic	0.01	+100% -0	25V	CKDYZ 103P 25
C14	Ceramic	100p		50V	CKDYZ 101K 50
C15	Ceramic	0.01	+100% -0	25V	CKDYZ 103P 25
C16	Ceramic	0.01	+100% -0	25V	CKDYZ 103P 25
C17	Ceramic	300p		50V	CCDSL 301K 50
C18	Electrolytic	1	± 20%	25V	CSYA 010M 25
C19	Electrolytic	5		10V	CEMX 5MF 10V
C20	Ceramic	10p		50V	CCDSL 100K 50

RESISTORS

Symbol	Description		Part No.
R1	Carbon film	470	RF¼PS 470-K
R2	Carbon film	56k	RF¼PS 56K-K
R3	Carbon film	470	RF¼PS 470-K
R4	Carbon film	56k	RF¼PS 56K-K
R5	Carbon film	10k	RF¼PS 10K-K
R6	Carbon film	2.2k	RF¼PS 2R2K-K
R7	Carbon film	6.8k	RF¼PS 6R8K-K
R8	Carbon film	100	RF¼PS 100-K
R9	Carbon film	220k	RF¼PS 220K-K
R10	Carbon film	220	RF¼PS 220-K
R11	Carbon film	820	RF¼PS 820-K
R12	Carbon film	47k	RF¼PS 47K-K
R13	Carbon film	33k	RF¼PS 33K-K
R14	Carbon film	33k	RF¼PS 33K-K
R15	Carbon film	33k	RF¼PS 33K-K

DIODES AND IC'S

Symbol	Description	Part No.
D1	1N60 Diode	
D2	1N60 Diode	
D3	1N60 Diode	
D4	1N60 Diode	
D5	1N60 Diode	
D6	1N60 Diode	
Q1	LM703L IC	
Q2	LM703L IC	
Q3	LM703L IC	
Q4	LM703L IC	

COIL AND TRANSFORMERS

Symbol	Description	Part No.
L1	RF Choke Coil	T24-029-0
T1	FM IFT	T73-022-0
T2	FM IFT	T73-022-0
T3	FM IFT	T73-022-0
T4	FM IFT (Det)	T74-003-0

MPX UNIT (AWD-001)

CAPACITORS

Symbol	Description				Part No.
C1	Electrolytic	2.2		10V	CEMX 2R2MF 10V
C2	Styrol	3300p		50V	C15-011-A
C3	Ceramic	68p		50V	CCDSL 680K 50
C4	Electrolytic	10		10V	CEMX 10MF 10V
C5	Ceramic	470p		50V	CKDZ 5P471K 50
C6	Ceramic	470p		50V	CKDZ 5P471K 50
C7	Electrolytic	4.7		10V	CSSA 4R7MF 10V
C8	Electrolytic	4.7		10V	CSSA 4R7MF 10V
C9	Electrolytic	0.47		25V	CSSA R47MF 25V
C10	Electrolytic	0.47		25V	CSSA R47MF 25V
C11	Mylar	5600p		50V	CQMA 562K 50V
C12	Mylar	5600p		50V	CQMA 562K 50V
C13	Electrolytic	10		10V	CEMX 10MF 10V
C14	Mylar	1500p		50V	CQMA 152K 50
C15	Electrolytic	22		10V	CEMX 22MF 10V
C16	Styrol	4700p		50V	CQSA 472K 50
C17	Electrolytic	10		10V	CEMX 10MF 10V
C18	Electrolytic	1		50V	CEMX 1MF 50V
C19	Electrolytic	4.7		25V	CEMX 4R7MF 25V

RESISTORS

Symbol	Description		Part No.
R1	Carbon film	100k	RF½PS 100K-K
R2	Carbon film	1k	RF½PS 1K-K
R3	Carbon film	47k	RF½PS 47K-K
R4	Carbon film	100k	RF½PS 100K-K
R5	Carbon film	220	RF½PS 220-K
R6	Carbon film	1k	RF½PS 1K-K
R7	Carbon film	4.7k	RF½PS 4R7K-K
R8	Carbon film	3.9k	RF½PS 3R9K-K
R9	Carbon film	100k	RF½VS 100K-K
R10	Carbon film	47k	RF½PS 47K-K
R11	Carbon film	47k	RF½PS 47K-K
R12	Carbon film	33k	RF½PS 33K-K
R13	Carbon film	1k	RF½PS 1K-K
R14	Carbon film	56k	RF½PS 56K-K
R15	Carbon film	56k	RF½PS 56K-K
R16	Carbon film	1.8k	RF½PS 1R8-K
R17	Carbon film	1.8k	RF½PS 1R8-K
R18	Carbon film	1.8k	RF½PS 1R8-K
R19	Carbon film	1.8k	RF½PS 1R8-K
R20	Carbon film	100k	RF½PS 100K-K
R21	Carbon film	100k	RF½PS 100K-K
R22	Carbon film	330k	RF½PS 330K-K
R23	Carbon film	330k	RF½PS 330K-K
R24	Carbon film	47k	RF½PS 47K-K
R25	Carbon film	47k	RF½PS 47K-K
R26	Carbon film	10k	RF½PS 10K-K
R27	Carbon film	10k	RF½PS 10K-K
R28	Carbon film	1.5k	RF½VS 1R5-K
R29	Carbon film	1.5k	RF½VS 1R5-K
R30	Carbon film	10k	RF½VS 10K-K
R31	Carbon film	33k	RF½PS 33K-K
R32	Carbon film	100	RF½VS 100-K
R33	Carbon film	10k	RF½VS 10K-K
R34	Carbon film	3.3k	RF½PS 3R3K-K
R35	Carbon film	1k	RF½VS 1K-K
R36	Carbon film	4.7k	RF½VS 4R7K-K
R37	Carbon film	47k	RF½PS 47K-K

DIODES AND TRANSISTORS

Symbol	Description	Part No.
D1	1S1555 Diode	
D2	1S1555 Diode	
D3	1S1555 Diode	
D4	1S1555 Diode	
D5	1S188 Diode	
D6	1S188 Diode	
D7	1S188 Diode	
Q1	2SC870-F	
Q2	2SC711-F	
Q3	2SC711-F	
Q4	2SC870-F	
Q5	2SC870-F	
Q6	2SC711-F	
Q7	2SC711-F	
Q8	2SC711-F	
Q9	2SC711-F	

TRANSFORMERS

Symbol	Description	Part No.
T1	19KHz MPX Transformer	ATM-001-A
T2	38KHz MPX Transformer	ATM-002-A
T3	19KHz (IND) Transformer	ATM-003-A
T4	19KHz MPX Coil	T75-023-B
T5	SCA Filter Coil	T75-007-0
T6	38KHz Filter	T75-015-A
T7	38KHz Filter	T75-015-A

POTENTIOMETERS

Symbol	Description	Part No.
VR1	Semi-fixed resistor	C92-026-0

AM TUNER UNIT (W14-010)

CAPACITORS

Symbol	Description			Part No.
C1	Ceramic	0.04	+100% -0	25V CKDYZ 403P 25
C2	Mylar	0.01	± 20%	50V CQMA 103M 50
C3	Ceramic	0.04	+100% -0	25V CKDYZ 403P 25
C4	Ceramic	0.04	+100% -0	25V CKDYZ 403P 25
C5	Mylar	0.01	± 20%	50V CQMA 103M 50
C6	Mica	68p	± 5%	50V CMA 680J 50
C7	Styrol	150p		50V CQSA 151K 50
C8	Styrol	410p		50V CQSA 411K 50
C9	Ceramic	10p		50V CCDSL 100K 50
C10	2 gang trimmer			C43-005-0
C11	Styrol	2700p		50V CQSA 272K 50
C12	Mica	180p	± 5%	50V CMA 181J 50
C13	Electrolytic	10		10V CEMX 10MF 10V
C14	Ceramic	0.04	+100% -0	25V CKDYZ 403P 25
C15	Ceramic	0.04	+100% -0	25V CKDYZ 403P 25
C16	Styrol	2700p		50V CQSA 272K 50
C17	Mica	180p	± 5%	50V CMA 181J 50
C18	Ceramic	0.04	+100% -0	25V CKDYZ 403P 25
C19	Ceramic	0.04	+100% -0	25V CKDYZ 403P 25
C20	Electrolytic	100		16V CEMX 100MF 16V
C21	Ceramic	0.04	+100% -0	25V CKDYZ 403P 25
C22	Ceramic	3p	± 0.25p	50V CCDSL 030C 50
C23	Mylar	1000p	± 20%	50V CQMA 102M 50
C24	Mylar	2000p	± 20%	50V CQMA 202M 50
C25	Mylar	1000p	± 20%	50V CQMA 102M 50
C26	Electrolytic	2.2		16V CEMX 2R2MF 16V
C27	Ceramic	0.04	+100% -0	25V CKDYZ 403P 25

RESISTORS

Symbol	Description		Part No.
R1	Carbon film	1k	RF½PS 1K-K
R2	Carbon film	4.7k	RF½PS 4R7K-K
R3	Carbon film	1k	RF½PS 1K-K
R4	Carbon film	470	RF½PS 470-K
R5	Carbon film	3.3k	RF½PS 3R3K-K
R6	Carbon film	18k	RF½PS 18K-K
R7	Carbon film	1k	RF½PS 1K-K
R8	Carbon film	1k	RF½PS 1K-K
R9	Carbon film	470	RF½PS 470-K
R10	Carbon film	4.7k	RF½PS 4R7K-K

R11	Carbon film	150k		RF½PS 150K-K
R12	Carbon film	680		RF½PS 680-K
R13	Carbon film	1k		RF½PS 1K-K
R14	Carbon film	27k		RF½PS 27K-K
R15	Carbon film	4.7k		RF½PS 4R7K-K
R16	Carbon film	470		RF½PS 470-K
R17	Carbon film	470		RF½PS 470-K
R18	Carbon film	39k		RF½PS 39K-K
R19	Carbon film	100		RF½PS 100-K
R20	Carbon film	2.7k		RF½PS 2R7K-K
R21	Carbon film	4.7k		RF½PS 4R7K-K
R22	Carbon film	10k		RF½PS 10K-K
R23	Carbon film	10k		RF½PS 10K-K
R24	Carbon film	470		RF½PS 470-K

DIODES AND TRANSISTORS

Symbol	Description	Part No.
D1	1N60 Diode	
D2	1N60 Diode	
D3	1N60 Diode	
D4	1N60 Diode	
Q1	2SC460-A Transistor	
Q2	2SC461-A Transistor	
Q3	2SC460-A Transistor	
Q4	2SC460-A Transistor	

COILS AND TRANSFORMERS

Symbol	Description	Part No.
T1	LW OSC Coil	T83-001-A
T2	MW OSC Coil	T43-004-A
T3	IF Transformer	T71-023-A
T4	IF Transformer	T71-023-A
T5	IF Transformer	T72-017-0

EUPHONIC UNIT (W15-036)

CAPACITORS

Symbol	Description			Part No.
C1	Electrolytic	220	35V	CEMX 220MF 35V
C2	Electrolytic	10	35V	CEMX 10MF 35V
C3	Electrolytic	1	35V	CEMX 1MF 35V
C4	Electrolytic	3.3	35V	CEMX 3R3MF 35V

RESISTORS

Symbol	Description			Part No.
R1	Carbon film	2.2k	½W	RF½PS 2R2K-K
R2	Carbon film (LN)	2.2k		RF½PS 2R2K-K, NL
R3	Carbon film (LN)	2.2k		RF½PS 2R2K-K, NL
R4	Carbon film (LN)	15k		RF½PS 15K-K, NL
R5	Carbon film (LN)	1.2k		RF½PS 1R2K-K, NL
R6	Carbon film (LN)	2.2k		RF½PS 2R2K-K, NL
R7	Carbon film (LN)	1k		RF½PS 1K-K, NL
R8	Carbon film (LN)	2.2k		RF½PS 2R2K-K, NL
R9	Carbon film (LN)	1k		RF½PS 1K-K, NL

TRANSISTOR

Symbol	Description	Part No.
Q1	2SC458LG	

HEAD AMP UNIT (W15-093)

CAPACITORS

Symbol	Description			Part No.
C1	Electrolytic	47	10V	CEMX 47MF 10V
C2	Electrolytic	47	10V	CEMX 47MF 10V
C3	Ceramic	470p	50V	CCDSL 471K 50
C4	Ceramic	470p	50V	CCDSL 471K 50
C5	Electrolytic	10	10V	CEMX 10MF 10V
C6	Electrolytic	10	10V	CEMX 10MF 10V
C7	Ceramic	100p	50V	CCDSL 101K 50
C8	Ceramic	100p	50V	CCDSL 101K 50
C9	Electrolytic	220	25V	CEMX 220MF 25V
C10	Electrolytic	220	25V	CEMX 220MF 25V
C11	Electrolytic	0.47	25V	CEMX R47MF 25V
C12	Electrolytic	0.47	25V	CEMX R47MF 25V
C13	Electrolytic	220	3V	CEMX 220MF 3V
C14	Electrolytic	220	3V	CEMX 220MF 3V
C15	Mylar	0.01	50V	CQMA 103K 50
C16	Mylar	0.01	50V	CQMA 103K 50
C17	Mylar	0.0033	50V	CQMA 332K 50
C18	Mylar	0.0033	50V	CQMA 332K 50
C19	Ceramic	330p	50V	CCDSL 331K 50
C20	Ceramic	330p	50V	CCDSL 331K 50

RESISTORS

Symbol	Description			Part No.
R1	Carbon film (LN)	1k		RF½PS 1K-K, NL
R2	Carbon film (LN)	1k		RF½PS 1K-K, NL
R3	Carbon film (LN)	270k		RF½PS 270K-K, NL
R4	Carbon film (LN)	270k		RF½PS 270K-K, NL
R5	Carbon film (LN)	100k		RF½PS 100K-K, NL
R6	Carbon film (LN)	100k		RF½PS 100K-K, NL
R7	Carbon film (LN)	390		RF½PS 390-K, NL
R8	Carbon film (LN)	390		RF½PS 390-K, NL
R9	Carbon film (LN)	330k		RF½PS 330K-K, NL
R10	Carbon film (LN)	330k		RF½PS 330K-K, NL
R11	Carbon film (LN)	15k		RF½PS 15K-K, NL
R12	Carbon film (LN)	15k		RF½PS 15K-K, NL
R13	Carbon film (LN)	2.2k		RF½PS 2R2K-K, NL
R14	Carbon film (LN)	2.2k		RF½PS 2R2K-K, NL
R15	Carbon film (LN)	4.7k		RF½PS 4R7K-K, NL
R16	Carbon film (LN)	4.7k		RF½PS 4R7K-K, NL
R17	Carbon film (LN)	220		RF½PS 220-K, NL
R18	Carbon film (LN)	220		RF½PS 220-K, NL
R19	Carbon film (LN)	15k		RF½PS 15K-K, NL
R20	Carbon film (LN)	15k		RF½PS 15K-K, NL
R21	Carbon film (LN)	330k		RF½PS 330K-K, NL
R22	Carbon film (LN)	330k		RF½PS 330K-K, NL
R23	Carbon film (LN)	27k		RF½PS 27K-K, NL
R24	Carbon film (LN)	27k		RF½PS 27K-K, NL
R25	Carbon film (LN)	33k		RF½PS 33K-K, NL
R26	Carbon film (LN)	33k		RF½PS 33K-K, NL

TRANSISTORS

Symbol	Description	Part No.
Q1	2SC458LG-C, B or 2SC871	
Q2	2SC458LG-C, B or 2SC871	
Q3	2SC458LG-C, B or 2SC871	
Q4	2SC458LG-C, B or 2SC871	

CONTROL AMP UNIT (W15-090)

CAPACITORS

Symbol	Description			Part No.
C1	Electrolytic	0.47	25V	CSYA R47 25
C2	Electrolytic	0.47	25V	CSYA R47 25
C3	Electrolytic	0.22 ± 20%	25V	CSYA R22M 25
C4	Electrolytic	0.22 ± 20%	25V	CSYA R22M 25
C5	Electrolytic	1 ± 20%	16V	CSYA 010M 16
C6	Electrolytic	1 ± 20%	16V	CSYA 010M 16
C7	Electrolytic	100	50V	CEMX 100MF 50V
C8	Electrolytic	100	50V	CEMX 100MF 50V
C9	Mylar	0.0047	50V	CQMA 472K 50
C10	Mylar	0.0047	50V	CQMA 472K 50
C11	Mylar	0.0047	50V	CQMA 472K 50
C12	Mylar	0.0047	50V	CQMA 472K 50
C13	Electrolytic	50	25V	CEMX 50MF 25V
C14	Electrolytic	50	25V	CEMX 50MF 25V
C15	Electrolytic	33	6.3V	CEMX 33MF 6R3V
C16	Electrolytic	33	6.3V	CEMX 33MF 6R3V
C17	Electrolytic	3.3	25V	CEMX 3R3MF 25V
C18	Electrolytic	3.3	25V	CEMX 3R3MF 25V
C19	Mylar	0.0022	50V	CQMA 222K 50
C20	Mylar	0.0022	50V	CQMA 222K 50
C21	Mylar	0.01	50V	CQMA 103K 50
C22	Mylar	0.01	50V	CQMA 103K 50
C23	Mylar	0.033	50V	CQMA 333K 50
C24	Mylar	0.033	50V	CQMA 333K 50
C25	Mylar	0.1	50V	CQMA 104K 50
C26	Mylar	0.1	50V	CQMA 104K 50

RESISTORS

Symbol	Description		Part No.
R1	Carbon film (LN)	330k	RF½PS 330K-K, NL
R2	Carbon film (LN)	330k	RF½PS 330K-K, NL
R3	Carbon film (LN)	33k	RF½PS 33K-K, NL
R4	Carbon film (LN)	33k	RF½PS 33K-K, N
R5	Carbon film (LN)	8.2k	RF½PS 8R2K-K, NL
R6	Carbon film (LN)	8.2k	RF½PS 8R2K-K, NL
R7	Carbon film (LN)	1k	RF½PS 1K-K, NL
R8	Carbon film (LN)	1k	RF½PS 1K-K, NL
R9	Carbon film (LN)	1k	RF½PS 1K-K, NL
R10	Carbon film (LN)	1k	RF½PS 1K-K, NL
R11	Carbon film	2.2k	RF½PS 2R2K-K
R12	Carbon film	2.2k	RF½PS 2R2K-K
R13	Carbon film	6.8k	RF½PS 6R8K-K
R14	Carbon film	6.8k	RF½PS 6R8K-K
R15	Carbon film	6.8k	RF½PS 6R8K-K
R16	Carbon film	6.8k	RF½PS 6R8K-K
R17	Carbon film (LN)	1k	RF½PS 1K-K, NL
R18	Carbon film (LN)	1k	RF½PS 1K-K, NL
R19	Carbon film (LN)	330k	RF½PS 330K-K, NL
R20	Carbon film (LN)	330k	RF½PS 330K-K, NL
R21	Carbon film	47k	RF½PS 47K-K
R22	Carbon film	47k	RF½PS 47K-K
R23	Carbon film (LN)	8.2k	RF½PS 8R2K-K, NL
R24	Carbon film (LN)	8.2k	RF½PS 8R2K-K, NL
R25	Carbon film	1.5k	RF½PS 1R5K-K
R26	Carbon film	1.5k	RF½PS 1R5K-K
R27	Carbon film	330	RF½PS 330-K
R28	Carbon film	330	RF½PS 330-K
R29	Carbon film	10k	RF½PS 10K-K

R30	Carbon film	10k	RF½PS 10K-K
R31	Carbon film	2.2k	RF½PS 2R2K-K
R32	Carbon film	2.2k	RF½PS 2R2K-K
R33	Carbon film	4.7k	RF½PS 4R7K-K
R34	Carbon film	4.7k	RF½PS 4R7K-K
R35	Carbon film	18k	RF½PS 18K-K
R36	Carbon film	18k	RF½PS 18K-K

TRANSISTORS

Symbol	Description	Part No.
Q1	2SC871-BL or GR	
Q2	2SC871-BL or GR	
Q3	2SC870	
Q4	2SC870	

MAIN AMP UNIT (W15-046)

CAPACITORS

Symbol	Description			Part No.
C1	Electrolytic	10	10V	CEMX 10MF 10V
C2	Electrolytic	10	10V	CEMX 10MF 10V
C3	Ceramic	220p	50V	CCDSL 221K 50
C4	Ceramic	220p	50V	CCDSL 221K 50
C5	Electrolytic	100	50V	CEMX 100MF 50V
C6	Electrolytic	100	50V	CEMX 100MF 50V
C7	Electrolytic	50	25V	CEMX 50MF 25V
C8	Electrolytic	50	25V	CEMX 50MF 25V
C9	Electrolytic	10	10V	CEMX 10MF 10V
C10	Electrolytic	10	10V	CEMX 10MF 10V
C11	Ceramic	220p	50V	CCDSL 221K 50
C12	Ceramic	220p	50V	CCDSL 221K 50
C13	Electrolytic	100	3V	CEMX 100MF 3V
C14	Electrolytic	100	3V	CEMX 100MF 3V
C15	Mylar	0.05	50V	CQMA 503K 50
C16	Mylar	0.05	50V	CQMA 503K 50
C17	Ceramic	56p	50V	CCDSL 560K 50
C18	Ceramic	56p	50V	CCDSL 560K 50

RESISTORS

Symbol	Description			Part No.
R1	Carbon film	220k		RF½PS 220K-K
R2	Carbon film	220k		RF½PS 220K-K
R3	Carbon film	27k		RF½PS 27K-K
R4	Carbon film	27k		RF½PS 27K-K
R5	Carbon film	5.6k		RF½PS 5R6K-K
R6	Carbon film	5.6k		RF½PS 5R6K-K
R7	Carbon film	1k		RF½PS 1K-K
R8	Carbon film	1k		RF½PS 1K-K
R9	Carbon film	150		RF½PS 150-K
R10	Carbon film	150		RF½PS 150-K
R11	Carbon film	47k		RF½PS 47K-K
R12	Carbon film	47k		RF½PS 47K-K
R13	Carbon film	4.7k		RF½PS 4R7K-K
R14	Carbon film	4.7k		RF½PS 4R7K-K
R15	Carbon film	1.5k		RF½PS 1R5K-K
R16	Carbon film	1.5k		RF½PS 1R5K-K
R17	Carbon film	3.3k		RF½PS 3R3K-K
R18	Carbon film	3.3k		RF½PS 3R3K-K
R19	Carbon film	150		RF½PS 150-K
R20	Carbon film	150		RF½PS 150-K
R21	Carbon film	330		RF½PS 330-K
R22	Carbon film	330		RF½PS 330-K
R23	Carbon film	22	½W	RF½PS 22-K
R24	Carbon film	22	½W	RF½PS 22-K

R25	Carbon film	330		RF½PS 330-K
R26	Carbon film	330		RF½PS 330-K
R27	Wire wound	0.5	2W	RS2P 0R5-K
R28	Wire wound	0.5	2W	RS2P 0R5-K
R29	Wire wound	0.5	2W	RS2P 0R5-K
R30	Wire wound	0.5	2W	RS2P 0R5-K
R31	Carbon film	10	½W	RF½PS 10-K
R32	Carbon film	10	½W	RF½PS 10-K
R33	Carbon film	4.7k		RF½PS 4R7K-K
R34	Carbon film	4.7k		RF½PS 4R7K-K

TRANSISTORS

Symbol	Description	Part No.
Q1	2SC458LG-C or B	
Q2	2SC458LG-C or B	
Q3	2SC905	
Q4	2SC905	
Q5	2SC497	
Q6	2SC497	
Q7	2SA497	
Q8	2SA497	

POTENTIOMETERS

Symbol	Description	Part No.
VR1	50kΩ Semi-fixed, Bias Adjust	C92-044-0
VR2	50kΩ Semi-fixed, Bias Adjust	C92-044-0
VR3	50Ω Semi-fixed, Bias Adjust	C92-043-0
VR4	50Ω Semi-fixed, Bias Adjust	C92-043-0

POWER SUPPLY UNIT (W16-013)

CAPACITORS

Symbol	Description				Part No.
C3	Electrolytic	100		50V	CEMX 100MF 50V
C4	Electrolytic	100		50V	CEMX 100MF 50V
C5	Electrolytic	10		50V	CEMX 10MF 50V
C6	Electrolytic	220		25V	CEMX 220MF 25V
C7	Electrolytic	220		25V	CEMX 220MF 25V
C8	Electrolytic	220		15V	CEMX 220MF 15V
C9	Ceramic	0.001		50V	CKDYZ 102K 50

RESISTORS

Symbol	Description				Part No.
R1	Carbon film	470			RF½PS 470-K
R2	Carbon film	10k			RF½PS 10K-K
R3	Carbon film	68k			RF½PS 68K-K
R4	Carbon film	3.3k			RF½PS 3R3K-K
R5	Carbon film	470			RF½PS 470-K
R6	Carbon film	39			RF½PS 39-K
R7	Carbon film	5.6			RF½PS 5R6-K
R8	Carbon film	1k			RF½PS 1K-K
R9	Carbon film	33			RF½PS 33-K
R10	Carbon film	33			RF½PS 33-K

DIODES AND TRANSISTORS

Symbol	Description	Part No.
D1	SD-2Z Diode	
D2	SD-2Z Diode	
D3	SE-05-02, FR-1P, SH-1S or SD-1Z Diode	
D4	SE-05-02, FR-1P, SH-1S or SD-1Z Diode	
SZ1	1S338Q Zener Diode	
Q1	2SC486-BL Transistor	
Q2	2SC486-BL Transistor	

COIL UNIT CAPACITORS

Symbol	Description				Part No.
C14	Ceramic	3p		50V	CCDSL030D50
C15	Ceramic	33p		50V	CCDSL330K50

COILS

Symbol	Description	Part No.
T1	MW Antenna Coil	T42-026-0
T2	LW Antenna Coil	T82-020-0

LX-880

- S₁ : INPUT SELECTOR**
 (1) AM
 (2) FM MONO
 (3) FM AUTO
 (4) PHONO MAG/CER
 (5) PHONO S-CONDUCT
 (6) MIC
 (7) AUX

- S₂ : MODE SELECTOR**
 NORMAL TAPE-MON
 (1) RIGHT (4) STEREO
 (2) LEFT (5) LEFT
 (3) STEREO (6) RIGHT

- S₃ : AM BAND SELECTOR**
 (1) LW
 (2) MW

- S₄ : OUTPUT SELECTOR**
 (1) POWER OFF
 (2) MAIN
 (3) EXTRA
 (4) MAIN+EXTRA
 (5) PHONES (SPEAKERS OFF)

- POTENTIOMETERS**
 VR₁ MAIN VOLUME
 VR₂ BASS CONTROL
 VR₃ TREBLE CONTROL
 VR₄ BALANCE CONTROL
 VR₅ MPX SEPARATION CONTROL

TOGGLE SWITCHES

- S₅ LOUDNESS CONTOUR ON ↔ OFF
 S₆ HIGH CUT FILTER ON ↔ OFF
 S₈ MUTING (FM) ON ↔ OFF

TOGGLE SWITCH

- S₇ AM BAND-WIDTH & AFC WIDE ↔ SHARP
 ON ↔ OFF

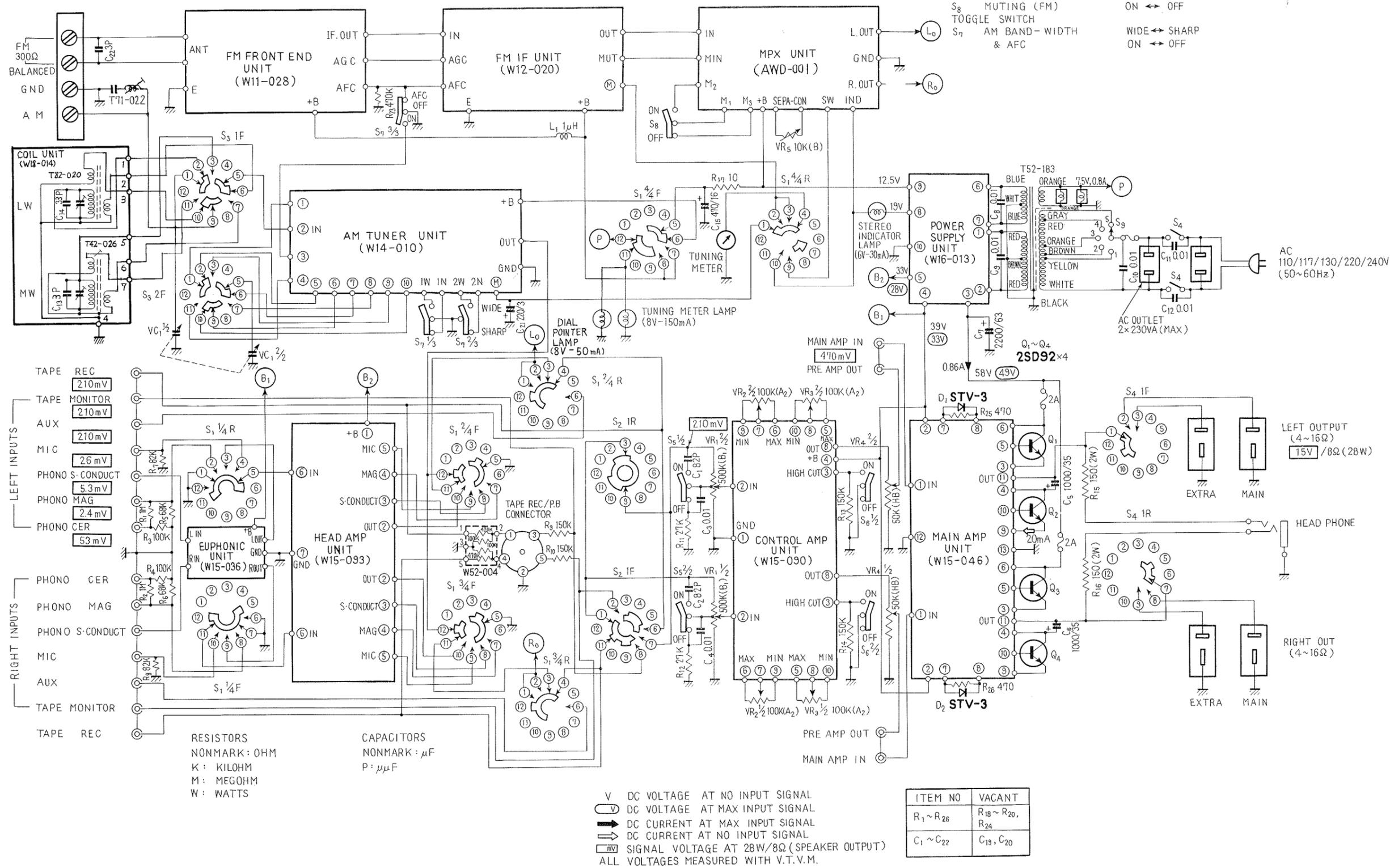

MODEL LX-880

CIRCUIT DIAGRAMS

<FW>

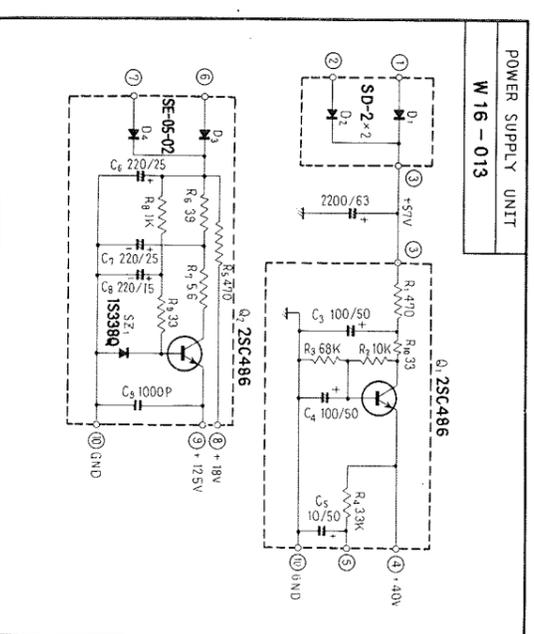
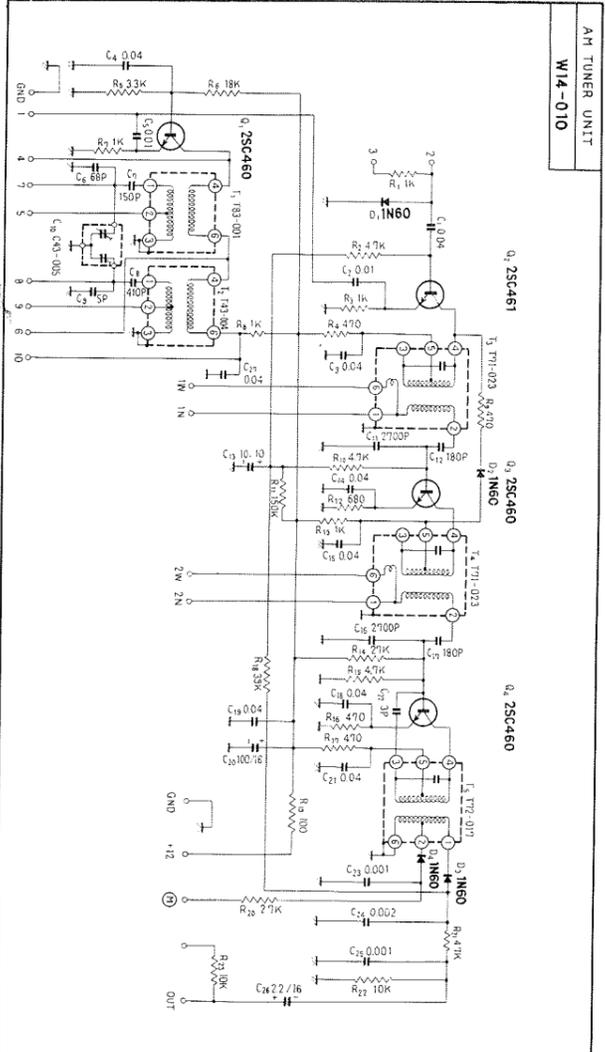
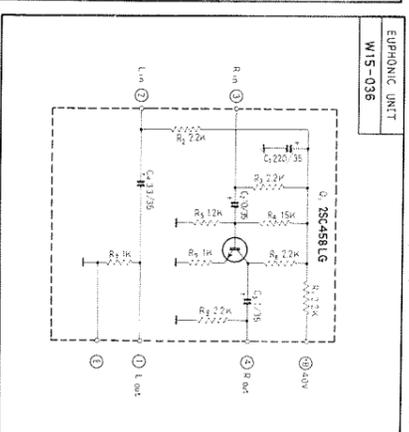
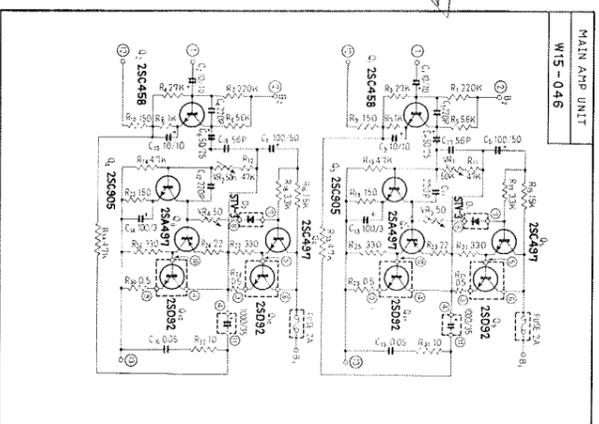
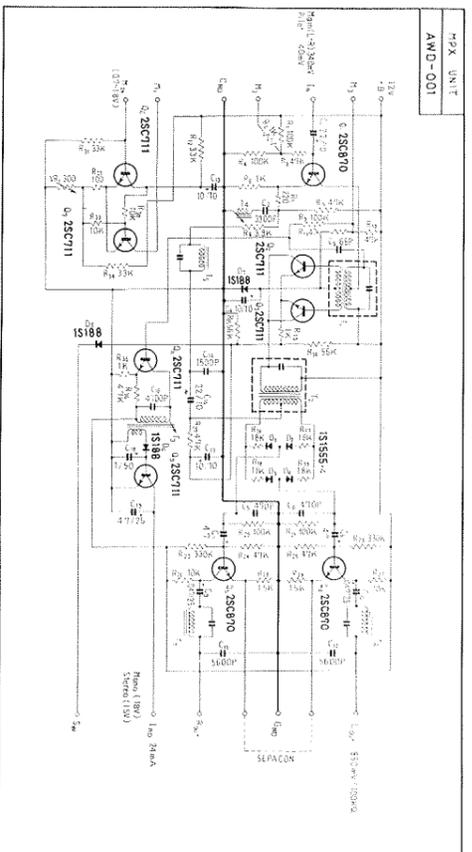
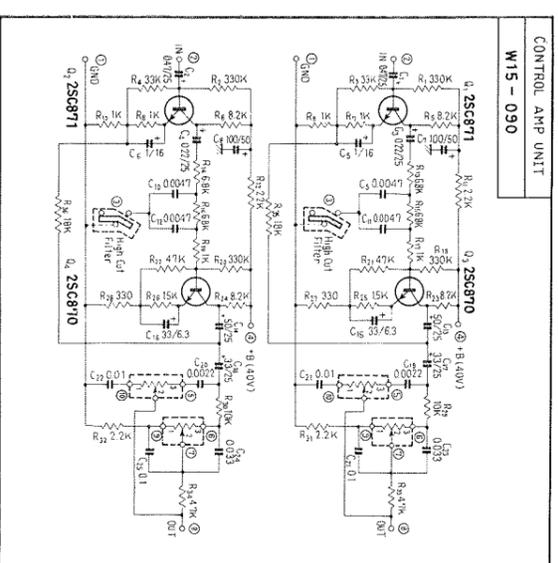
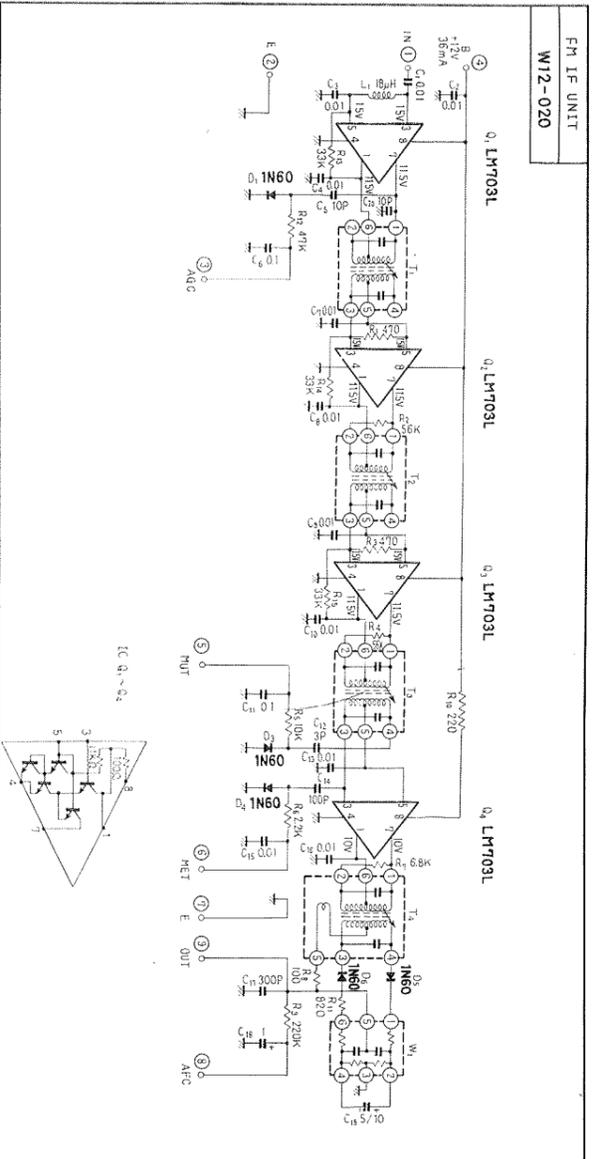
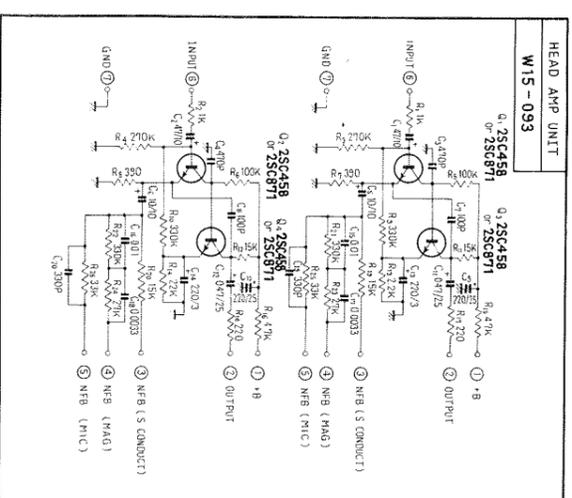
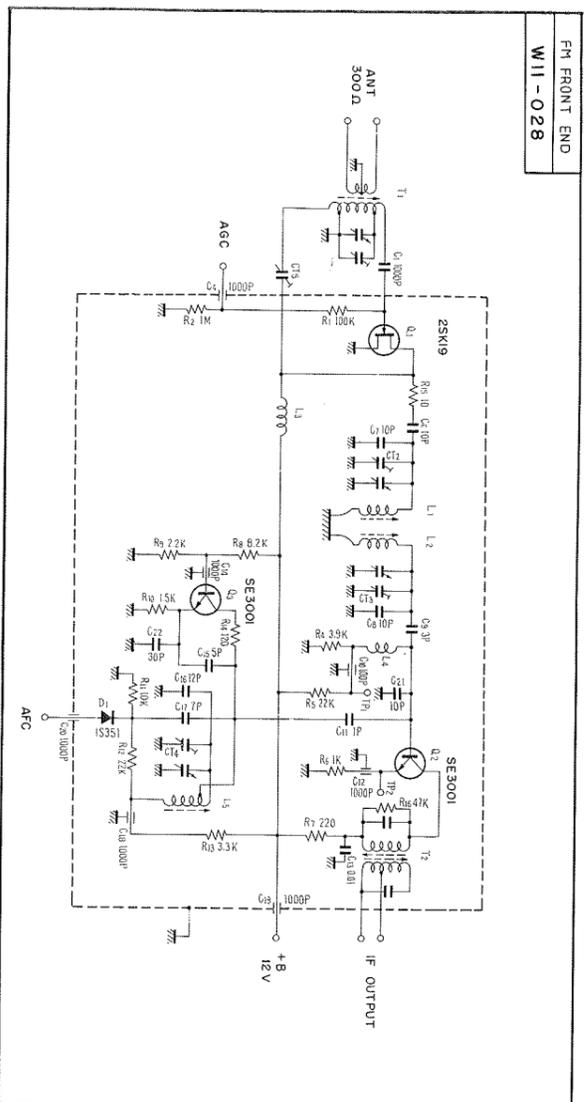

PIONEER

PIONEER ELECTRONIC CORPORATION

15-5, 4-Chome, Ohmori-nishi, Ohta-ku, Tokyo, Japan

U.S. PIONEER ELECTRONICS CORPORATION

178 Commerce Road, Carlstadt, New Jersey 07072 U. S. A.

PIONEER ELECTRONIC (EUROPE) N.V.

Noorderlaan 83, 2030 Antwerp, Belgium