

Service Manual

Pioneer

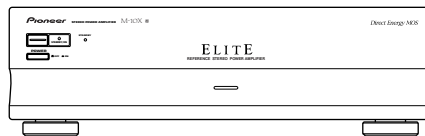

The illustration shows the KU/CA type

ORDER NO.
RRV2382

STEREO POWER AMPLIFIER

M-10X

THIS MANUAL IS APPLICABLE TO THE FOLLOWING MODEL(S) AND TYPE(S).

Type	Model	Power Requirement	Remarks
	M-10X		
KU/CA	○	AC120V	
MY	○	AC220-230V	

CONTENTS

1. SAFETY INFORMATION	2	7. GENERAL INFORMATION	20
2. EXPLODED VIEWS AND PARTS LIST	3	7.1 IC	20
3. BLOCK DIAGRAM AND SCHEMATIC DIAGRAM	6	7.2 CIRCUIT DESCRIPTION	21
4. PCB CONNECTION DIAGRAM	12	8. PANEL FACILITIES AND SPECIFICATIONS	21
5. PCB PARTS LIST	16		
6. ADJUSTMENT	19		

1. SAFETY INFORMATION

This service manual is intended for qualified service technicians; it is not meant for the casual do-it-yourselfer. Qualified technicians have the necessary test equipment and tools, and have been trained to properly and safely repair complex products such as those covered by this manual. Improperly performed repairs can adversely affect the safety and reliability of the product and may void the warranty. If you are not qualified to perform the repair of this product properly and safely, you should not risk trying to do so and refer the repair to a qualified service technician.



WARNING

This product contains lead in solder and certain electrical parts contain chemicals which are known to the state of California to cause cancer, birth defects or other reproductive harm.

Health & Safety Code Section 25249.6 – Proposition 65



NOTICE

(FOR CANADIAN MODEL ONLY)

Fuse symbols  (fast operating fuse) and/or  (slow operating fuse) on PCB indicate that replacement parts must be of identical designation.

REMARQUE

(POUR MODÈLE CANADIEN SEULEMENT)

Les symboles de fusible  (fusible de type rapide) et/ou  (fusible de type lent) sur CCI indiquent que les pièces de remplacement doivent avoir la même désignation.

(FOR USA MODEL ONLY)

1. SAFETY PRECAUTIONS

The following check should be performed for the continued protection of the customer and service technician.

LEAKAGE CURRENT CHECK

Measure leakage current to a known earth ground (water pipe, conduit, etc.) by connecting a leakage current tester such as Simpson Model 229-2 or equivalent between the earth ground and all exposed metal parts of the appliance (input/output terminals, screwheads, metal overlays, control shaft, etc.). Plug the AC line cord of the appliance directly into a 120V AC 60 Hz outlet and turn the AC power switch on. Any current measured must not exceed 0.5 mA.

ANY MEASUREMENTS NOT WITHIN THE LIMITS OUTLINED ABOVE ARE INDICATIVE OF A POTENTIAL SHOCK HAZARD AND MUST BE CORRECTED BEFORE RETURNING THE APPLIANCE TO THE CUSTOMER.

2. PRODUCT SAFETY NOTICE

Many electrical and mechanical parts in the appliance have special safety related characteristics. These are often not evident from visual inspection nor the protection afforded by them necessarily can be obtained by using replacement components rated for voltage, wattage, etc. Replacement parts which have these special safety characteristics are identified in this Service Manual.

Electrical components having such features are identified by marking with a  on the schematics and on the parts list in this Service Manual.

The use of a substitute replacement component which does not have the same safety characteristics as the PIONEER recommended replacement one, shown in the parts list in this Service Manual, may create shock, fire, or other hazards.

Product Safety is continuously under review and new instructions are issued from time to time. For the latest information, always consult the current PIONEER Service Manual. A subscription to, or additional copies of, PIONEER Service Manual may be obtained at a nominal charge from PIONEER.

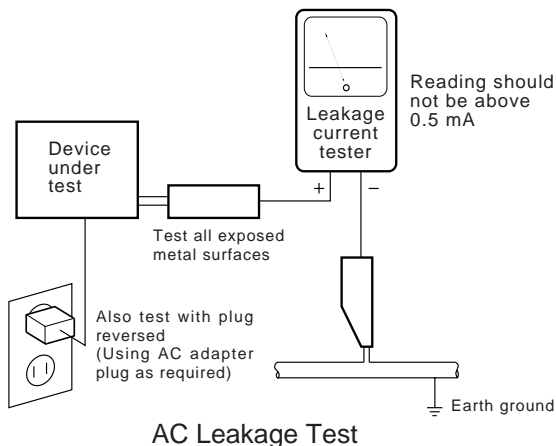

2. EXPLODED VIEWS AND PARTS LIST

- NOTES :
- Parts marked by “NSP” are generally unavailable because they are not in our Master Spare Parts List.
 - The \triangle mark found on some component parts indicates the importance of the safety factor of the part. Therefore, when replacing, be sure to use parts of identical designation.
 - Screws adjacent to \blacktriangledown mark on the product are used for disassembly.

2.1 PACKING

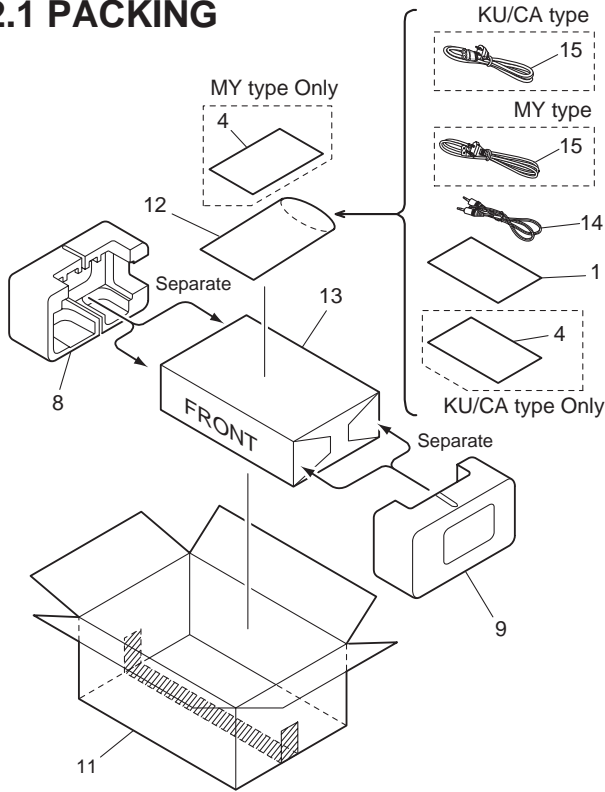

(1) PACKING PARTS LIST

Mark	No.	Description	Part No.
	1	Operating Instructions	See Contrast table (2)
	2	
	3	
NSP	4	Warranty Card	See Contrast table (2)
	5	
	6	
	7	
	8	Side Protector L	AHA7127
	9	Side Protector R	AHA7128
	10	
NSP	11	Packing Case	See Contrast table (2)
	12	Literature Bag	AHG-117
	13	Packing Sheet	AHG1016
	14	Remote Control Cord	PDE1247
\triangle	15	Power Cord	See Contrast table (2)

(2) CONTRAST TABLE

M-10X/KU/CA and MY are constructed the same except for the following:

Mark	No.	Symbol and Description	Part No.		Remarks
			KU/CA type	MY type	
	1	Operating Instructions (English)	ARC7331	Not used	
	1	Operating Instructions (English/French/German/Italian/Dutch/Swedish/Spanish/Portuguese)	Not used	ARC7332	
NSP	4	Warranty Card	ARY1026	ARY7022	
	11	Packing Case	AHD7946	AHD7947	
\triangle	15	Power Cord	ADG7021	ADG1154	

ACCESSORIES

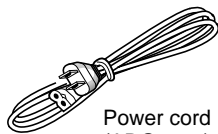

Power cord (ADG7021)
(For KU/CA type)

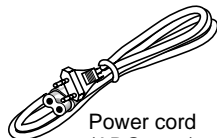

Power cord (ADG1154)
(For MY type)

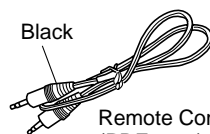

Remote Control Cord (PDE1247)
(L= 1 m)

- Operating Instructions (ARC7331: KU/CA type) (ARC7332: MY type)
- Warranty Card

2.2 EXTERIOR

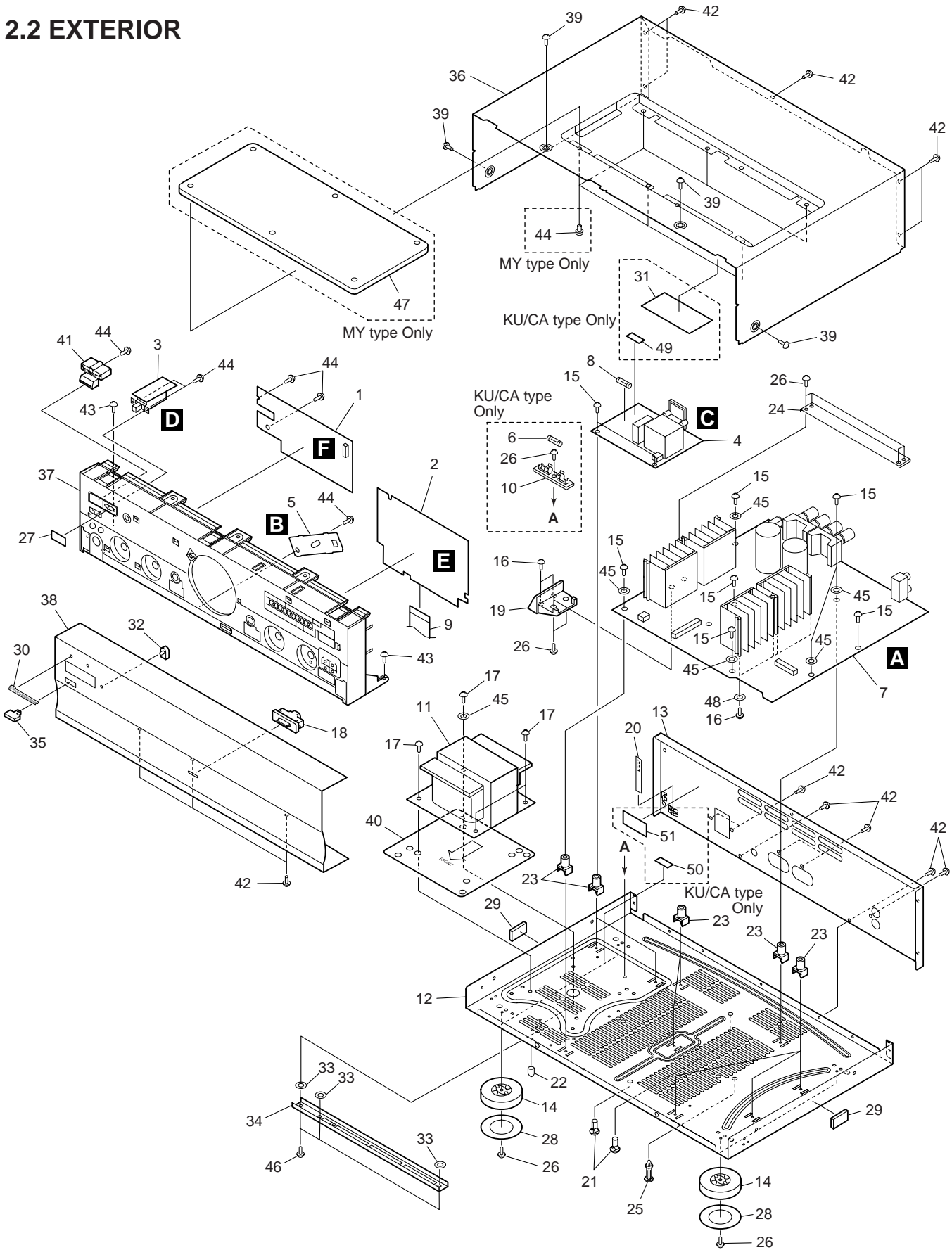

(1) EXTERIOR SECTION PARTS LIST

Mark	No.	Description	Part No.	Mark	No.	Description	Part No.
	1	FRONT L Assy	AWX7766		26	Screw	BBZ30P080FCC
	2	FRONT R Assy	AWX7768		27	PVC Cover	See Contrast table (2)
	3	POWER SW Assy	AWX7057		28	Cushion 55	PNM1316
	4	AC PRIMARY Assy	See Contrast table (2)		29	Rubber Cushion	AEB7004
	5	LED Assy	AWX7770		30	Name Plate	See Contrast table (2)
⚠	6	Fuse (15A)	See Contrast table (2)		31	65 Label	See Contrast table (2)
	7	AF Assy	See Contrast table (2)		32	LED Lens	PNW2019
⚠	8	Fuse	See Contrast table (2)		33	Spacer	ABF7004
	9	Flexible Cable (J1, 21P) (AF CN202 – FRONT R CN601)	ADD1114	NSP	34	Sub Flame	ANG7137
⚠	10	Fuse Holder	See Contrast table (2)		35	Main Power Button	See Contrast table (2)
⚠	11	Power Transformer (T1)	See Contrast table (2)		36	Bonnet Case	See Contrast table (2)
NSP	12	Chassis	ANA7048		37	Panel Base	See Contrast table (2)
	13	Rear Panel	See Contrast table (2)		38	Front Panel	See Contrast table (2)
	14	Insulator	PNW2766		39	Screw	See Contrast table (2)
	15	Screw	ABA1018		40	Trans Plate	ANG7228
	16	Screw	ABA1050		41	Power Button	See Contrast table (2)
	17	Screw (4x12)	ABA1014		42	Screw	BBT30P080FCC
	18	Lens Assy	AEC7321		43	Screw	BBZ30P060FCC
NSP	19	PCB Mold	AMR7222		44	Screw	BPZ30P080FMC
	20	Barrier	AEC7072		45	Washer	WG40FCC
NSP	21	PCB Holder	AEC7057		46	Screw	ABA1193
	22	Stud Cover	AEC7096		47	Top Cover	See Contrast table (2)
NSP	23	PCB Mold	AMR1525	NSP	48	Washer	AEE7027
NSP	24	Radiator Plate L	AMR7341	NSP	49	Fuse Card	See Contrast table (2)
	25	Locking Card Spacer	DEC1908	NSP	50	Fuse Card	See Contrast table (2)
				NSP	51	Fuse Caution Label	See Contrast table (2)

(2) CONTRAST TABLE

M-10X/KU/CA and MY are constructed the same except for the following:

Mark	No.	Symbol and Description	Part No.		Remarks
			KU/CA type	MY type	
⚠	4	AC PRIMARY Assy	AWX7771	AWX7056	
	6	Fuse (15A)	AEK7070	Not used	
⚠	7	AF Assy	AWX7776	AWX7767	
	8	Fuse	REK1085 (6.3A/125V)	REK1025 (T2AL250V)	
⚠	10	Fuse Holder	AKR1005	Not used	
⚠	11	Power Transformer (T1)	ATS7298	ATS7297	
	13	Rear Panel	ANC7982	ANC7983	
	27	PVC Cover	AAK7845	AAK7844	
	30	Name Plate	PAN1376	PAN1377	
	31	65 Label	ARW7050	Not used	
	35	Main Power Button	AAD7437	AAD7596	
	36	Bonnet Case	ANE7185	ANE7264	
	37	Panel Base	AMB7736	AMB7735	
	38	Front Panel	ANB7255	ANB7252	
	39	Screw	BBT30P080FZK	BBT30P080FNI	
	41	Power Button	AAD7436	AAD7446	
	47	Top Cover	Not used	AME7371	
NSP	49	Fuse Card	AAX1180	Not used	
NSP	50	Fuse Card	AAX7832	Not used	
NSP	51	Fuse Caution Label	AAX7831	Not used	

3. BLOCK DIAGRAM AND SCHEMATIC DIAGRAM

3.1 BLOCK DIAGRAM AND OVERALL SCHEMATIC DIAGRAM

A

B

C

D

E FRONT R ASSY (AWX7768)

B LED ASSY (AWX7770)

A AF ASSY (AWX7776: KU/CA type)
(AWX7767: MY type)

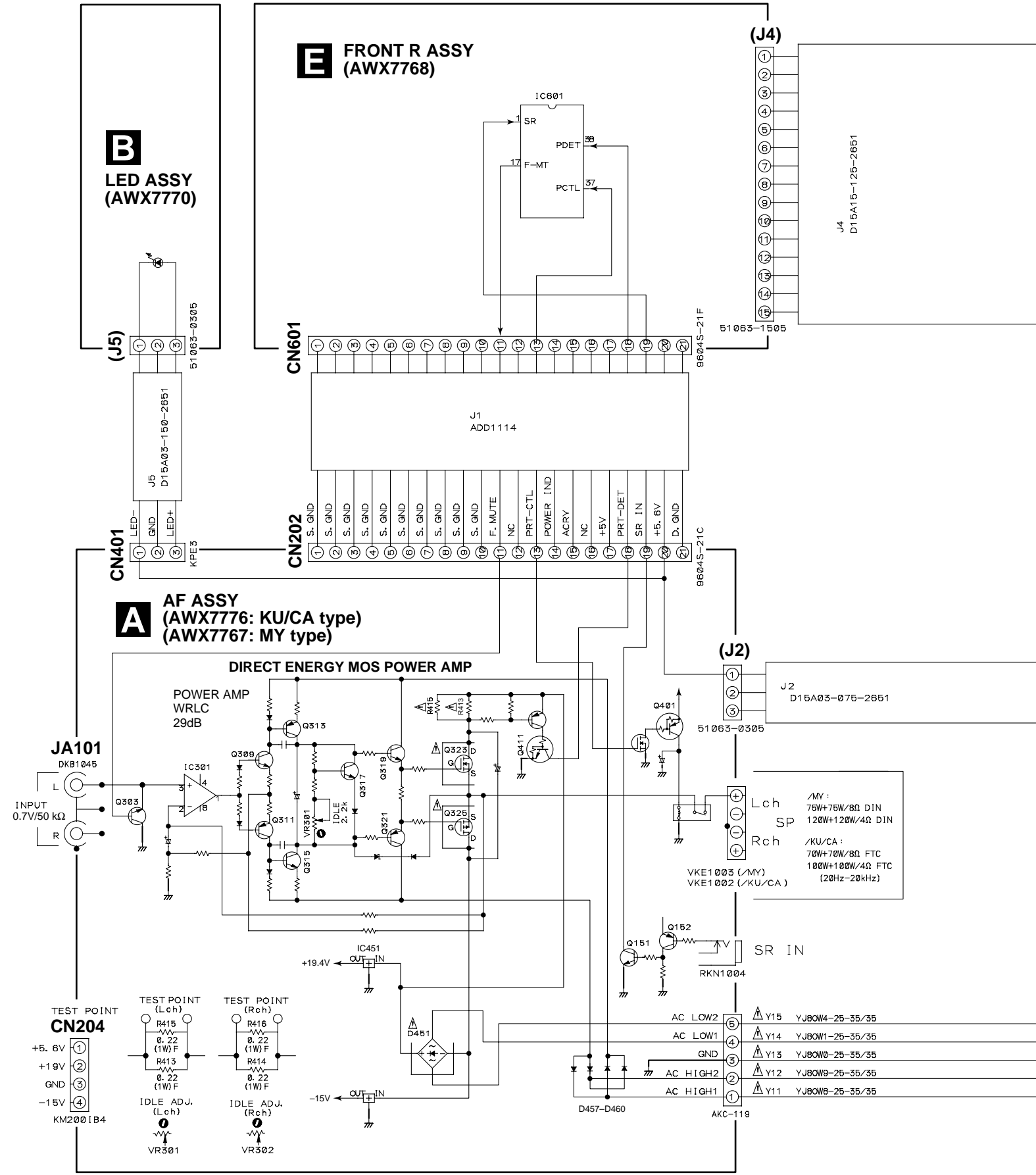

3.2 AF and LED ASSYS



A

AF ASSY
(AWX7776: KU/CA type)
(AWX7767: MY type)

A

B

C

D

- NOTES
- RESISTORS
INDICATED IN Ω 1/4W \pm 5% TOLERANCE UNLESS OTHERWISE NOTED k:k Ω M:M Ω
F:FL:NON-FRAMABLE TYPE
Fu:NON-FRAMABLE TYPE (QUICK OPEN TYPE)
R : RDR TYPE
 - CAPACITORS
INDICATED IN CAPACITY (μ F) /VOLTAGE (V) UNLESS OTHERWISE NOTED p:pF
INDICATED WITHOUT VOLTAGE IS 50V EXCEPT ELECTROLYTIC CAPACITOR.
BA:CEBA TYPE NA:CENA TYPE TY:CFTYA TYPE
 - INDUCTORS
INDICATED IN μ H, \pm 10%
 - DIODES
NO MARK DIODES ARE HSS104-02
 - VOLTAGE
INDICATED IN DC VOLTAGE (NO SIGNAL/DIN POWER OUT)

A

INPUT
JA101
DRB1045

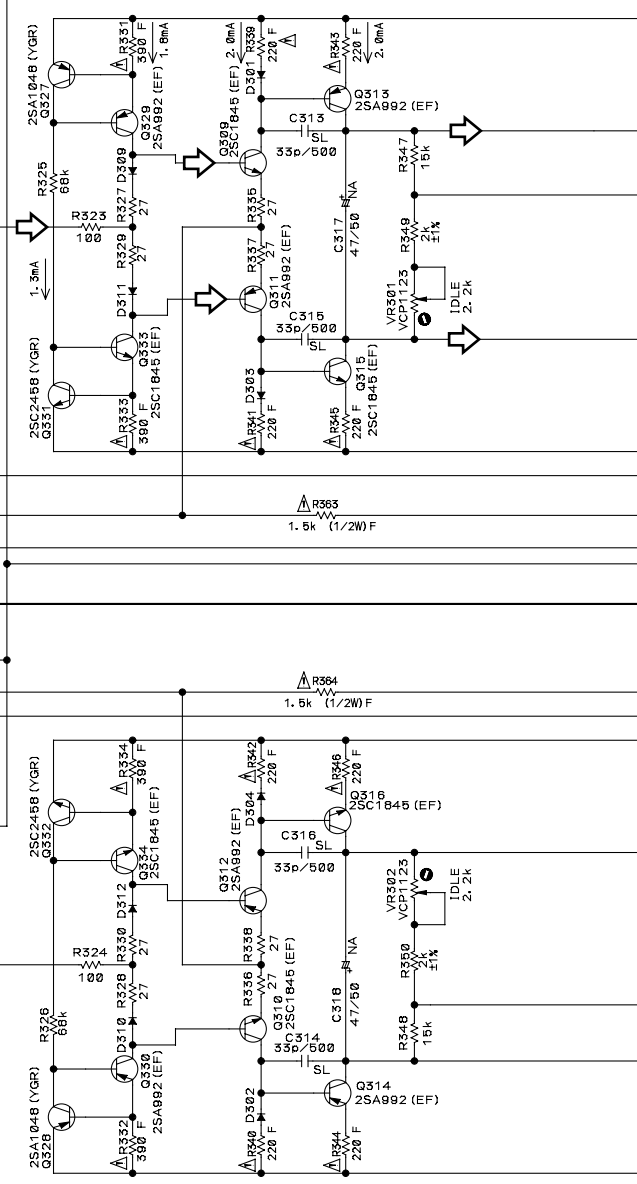
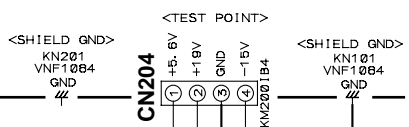

CN803

⇒ : Audio Signal Route (L ch)

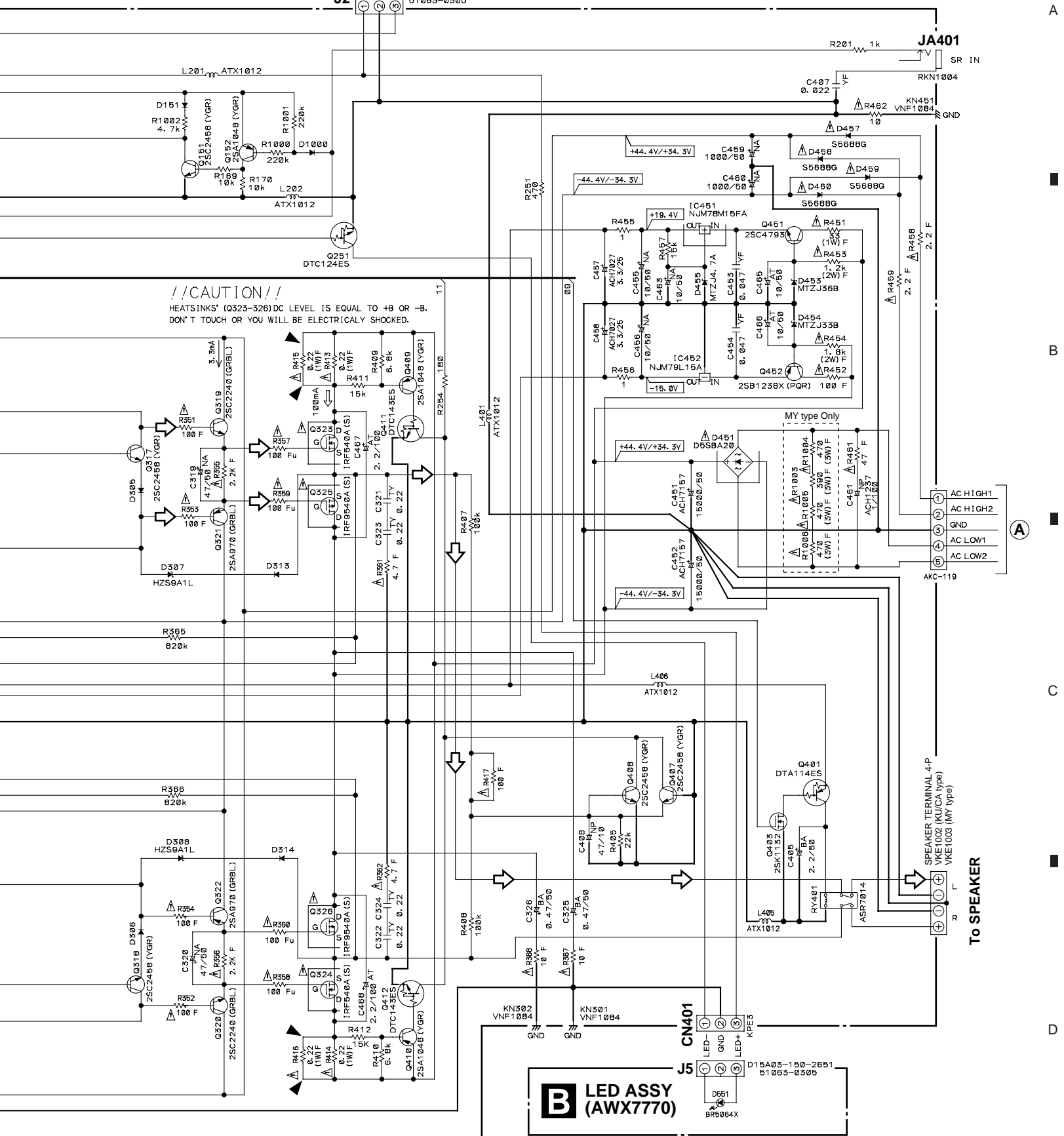

3.3 AC PRIMARY, POWER SW, FRONT R and FRONT L ASSYS

• NOTE FOR FUSE REPLACEMENT

CAUTION - FOR CONTINUED PROTECTION AGAINST RISK OF FIRE. REPLACE WITH SAME TYPE AND RATINGS OF FUSE.

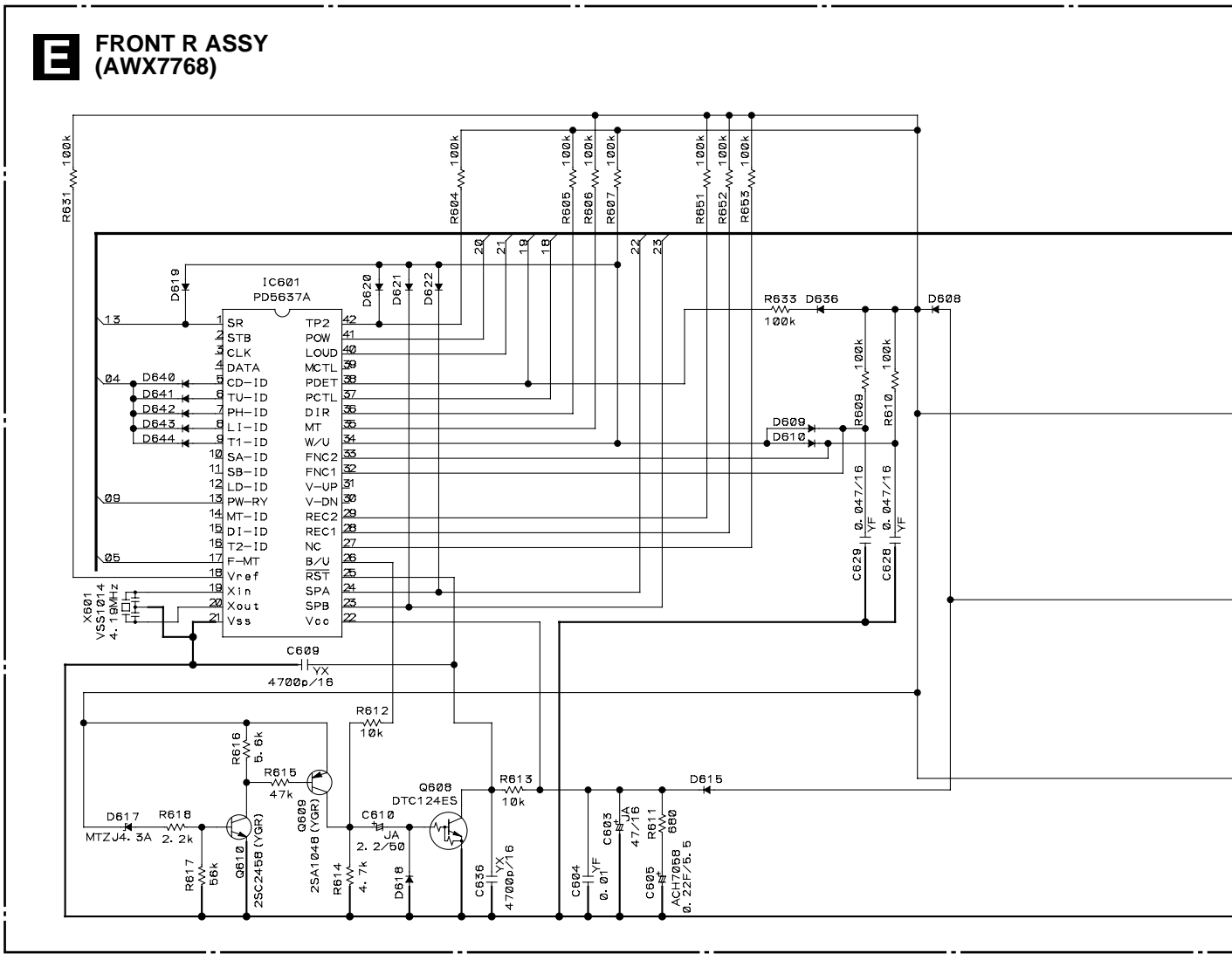
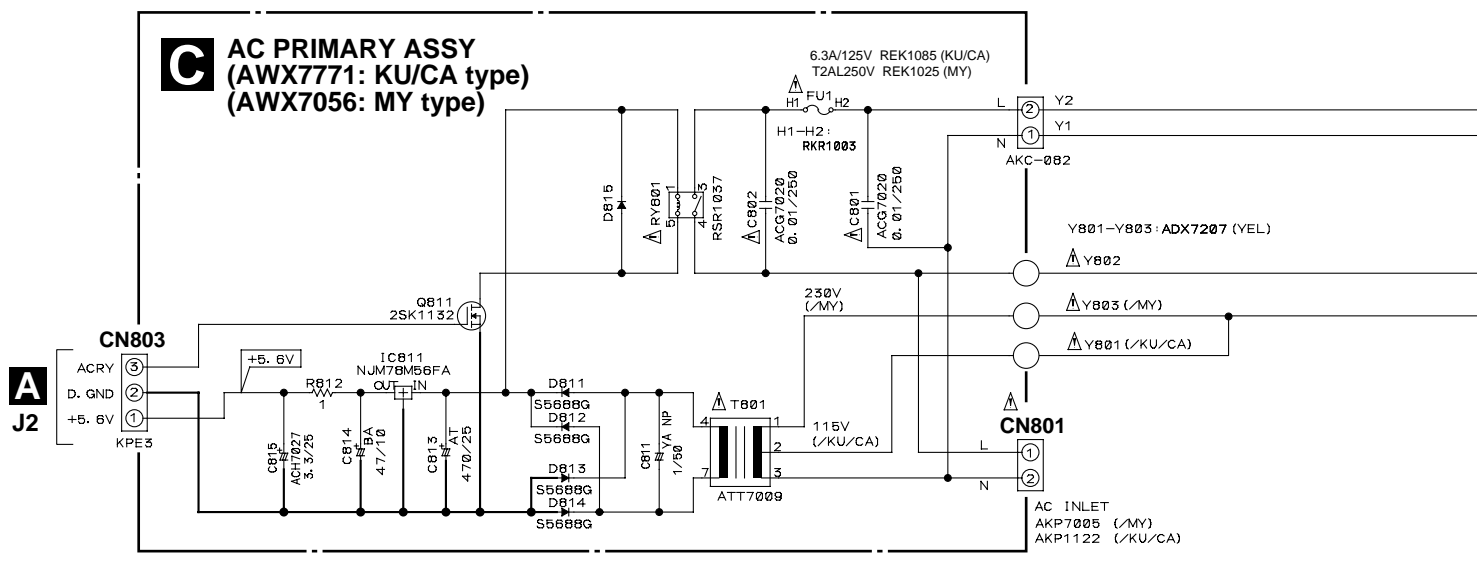

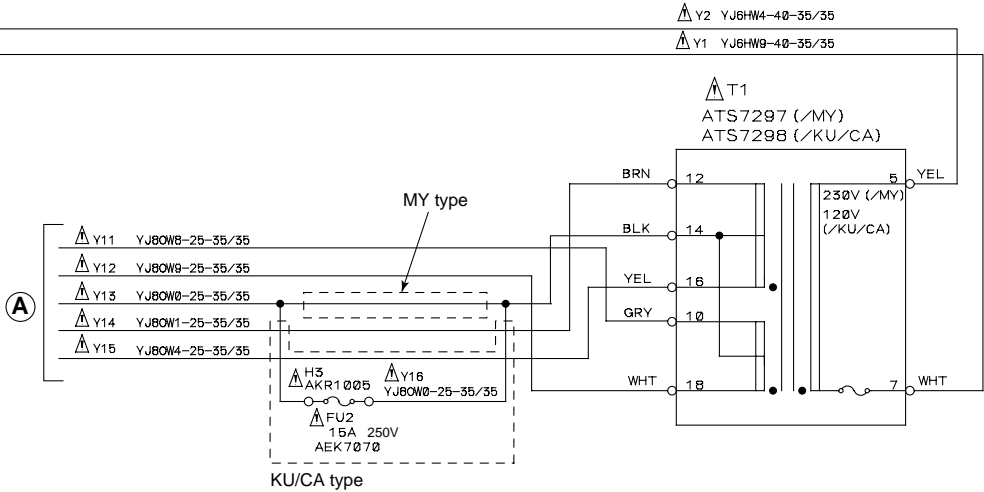
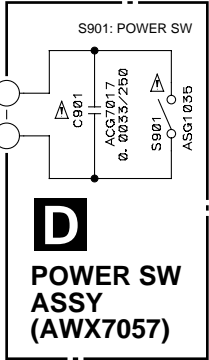

NOTE FOR FUSE REPLACEMENT

CAUTION - FOR CONTINUED PROTECTION AGAINST RISK OF FIRE. REPLACE WITH SAME TYPE AND RATINGS OF FUSE.

NOTES

- RESISTORS
INDICATED IN Ω 1/4W \pm 5% TOLERANCE UNLESS NOTED k; k Ω M; M Ω
- CAPACITORS
INDICATED IN CAPACITY (μ F) / VOLTAGE (V) UNLESS OTHERWISE NOTED p; pF
INDICATED WITHOUT VOLTAGE IS 50V EXCEPT ELECTROLYTIC CAPACITOR
JA:CEJA BA:CEBA YA:CEYA
- INDUCTORS
INDICATED IN μ H, \pm 10%
- DIODES
NO MARK DIODES ARE HSS104-02
- VOLTAGE
INDICATED IN DC VOLTAGE

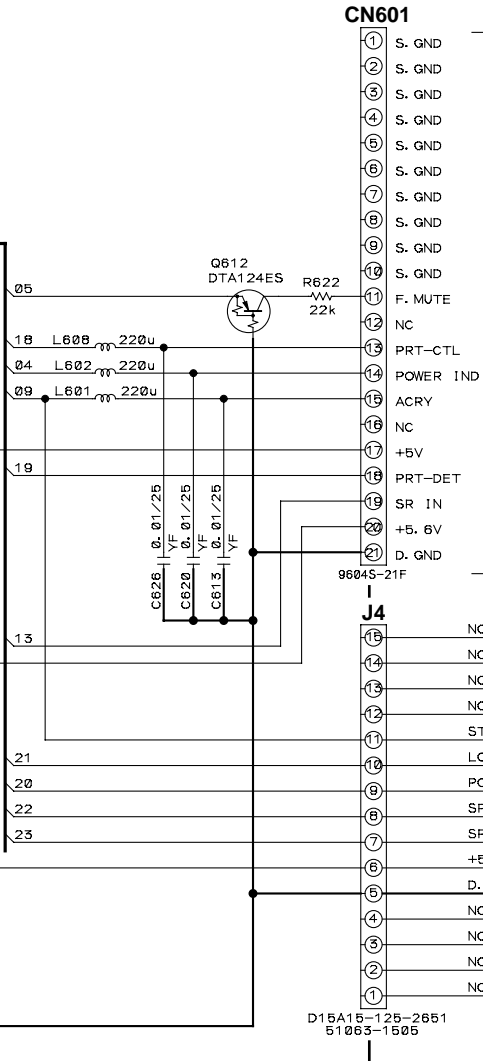

A
CN202

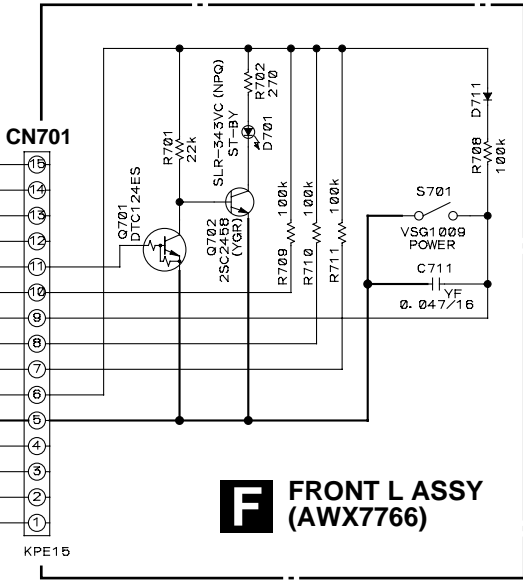

F
FRONT L ASSY (AWX7766)



4. PCB CONNECTION DIAGRAM

4.1 AF and LED ASSYS

SIDE A

To POWER TRANSFORMER T1

C CN803

NOTE FOR PCB DIAGRAMS:

1. Part numbers in PCB diagrams match those in the schematic diagrams.
2. A comparison between the main parts of PCB and schematic diagrams is shown below.

Symbol in PCB Diagrams	Symbol in Schematic Diagrams	Part Name
		Transistor
		Transistor with resistor
		Field effect transistor
		Resistor array
		3-terminal regulator

3. The parts mounted on this PCB include all necessary parts for several destination. For further information for respective destinations, be sure to check with the schematic diagram.

4. Viewpoint of PCB diagrams

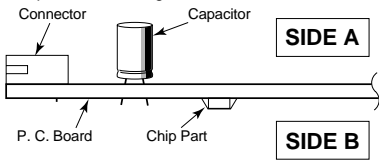

B LED ASSY

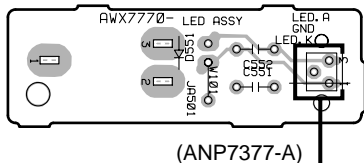

A AF ASSY

Rear

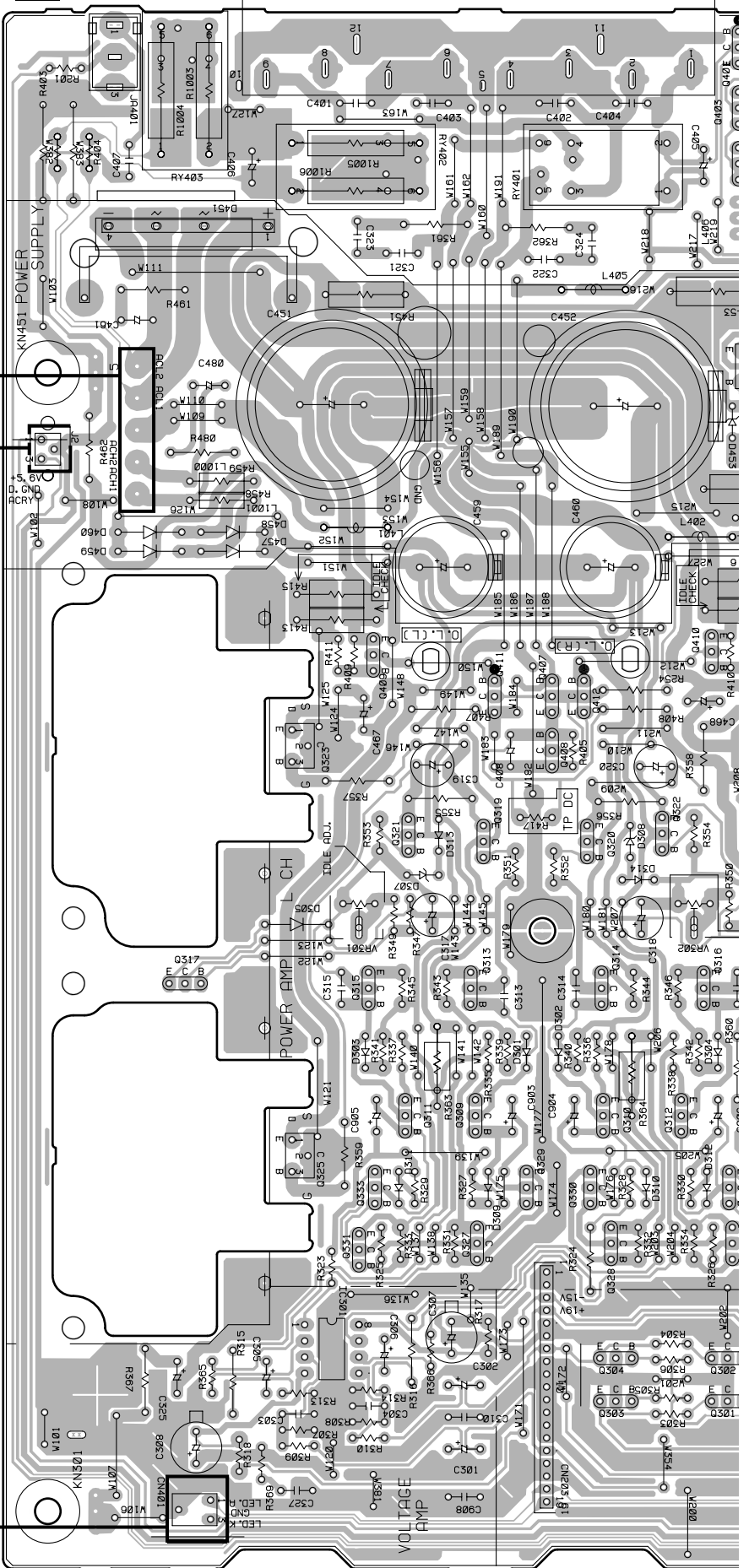

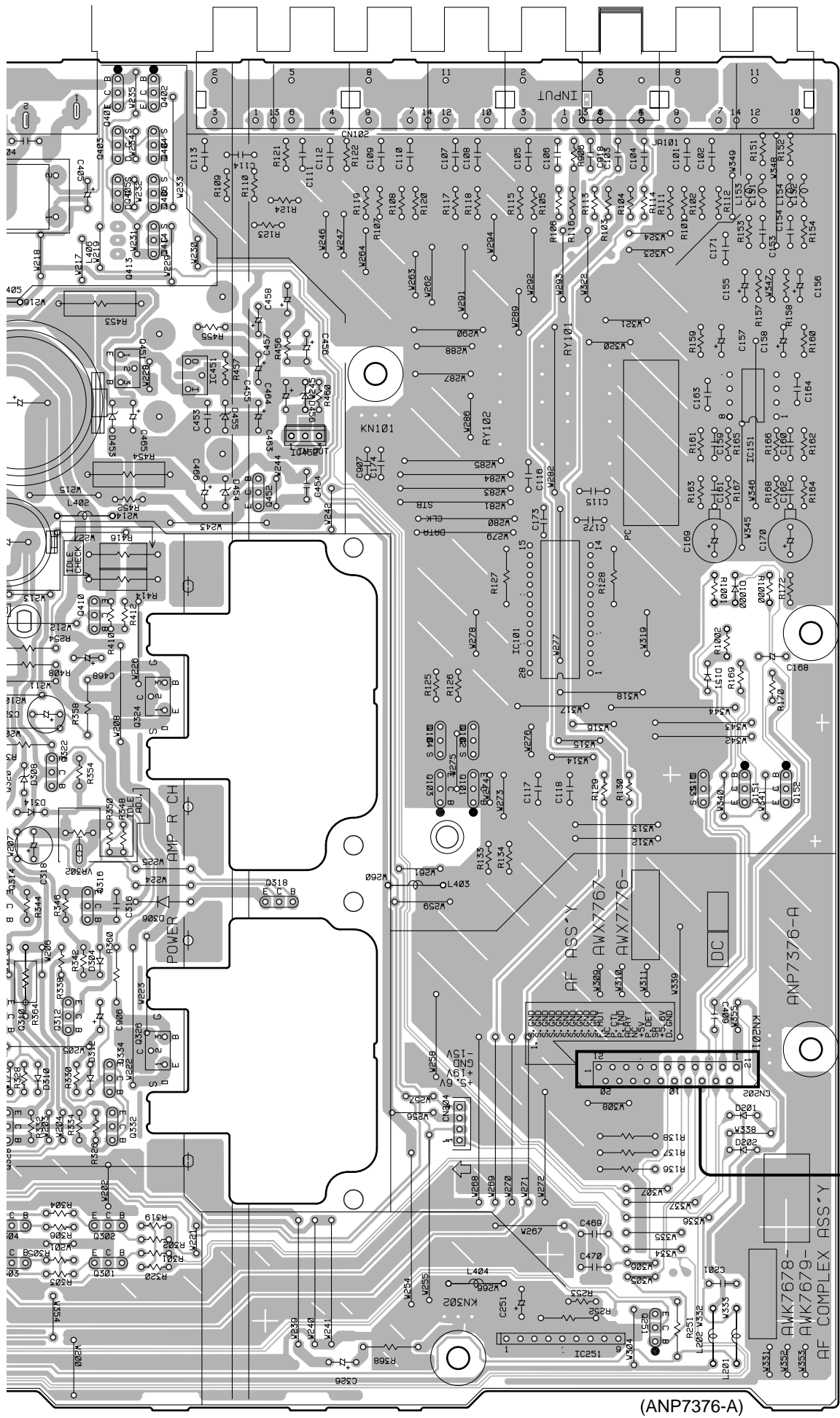

- Q401
- Q406
- Q413 Q414
- Q451 IC451 IC151 IC452
- Q452
- IC101
- Q409 Q410
- Q411 Q407 Q412
- Q323 Q408 Q324
- Q319 Q101 Q151
- Q322 Q104 Q153
- VR301 VR302
- Q313 Q318
- Q309 Q312
- Q325
- Q334
- E** CN601
- Q301 Q304
- IC251 Q251

A

B

C

D

(ANP7376-A)

4.2 AC PRIMARY, POWER SW, FRONT R and FRONT L ASSYS

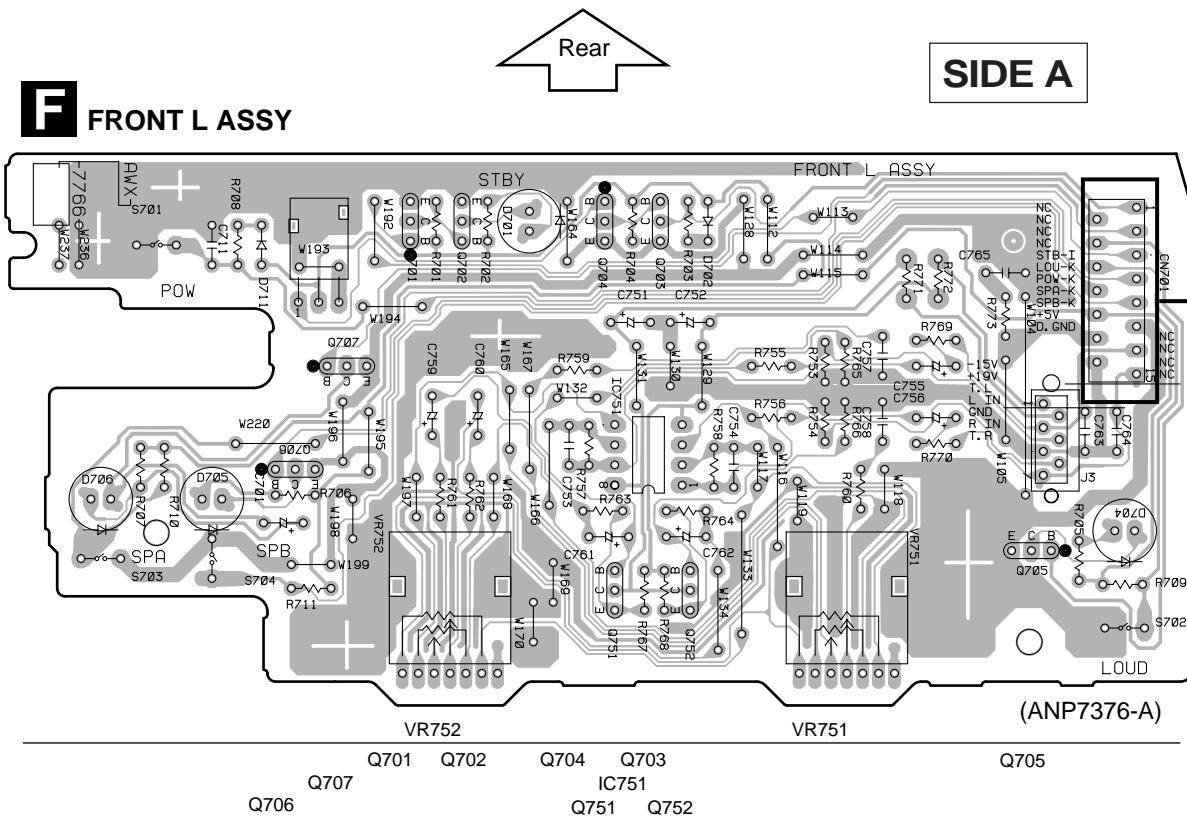
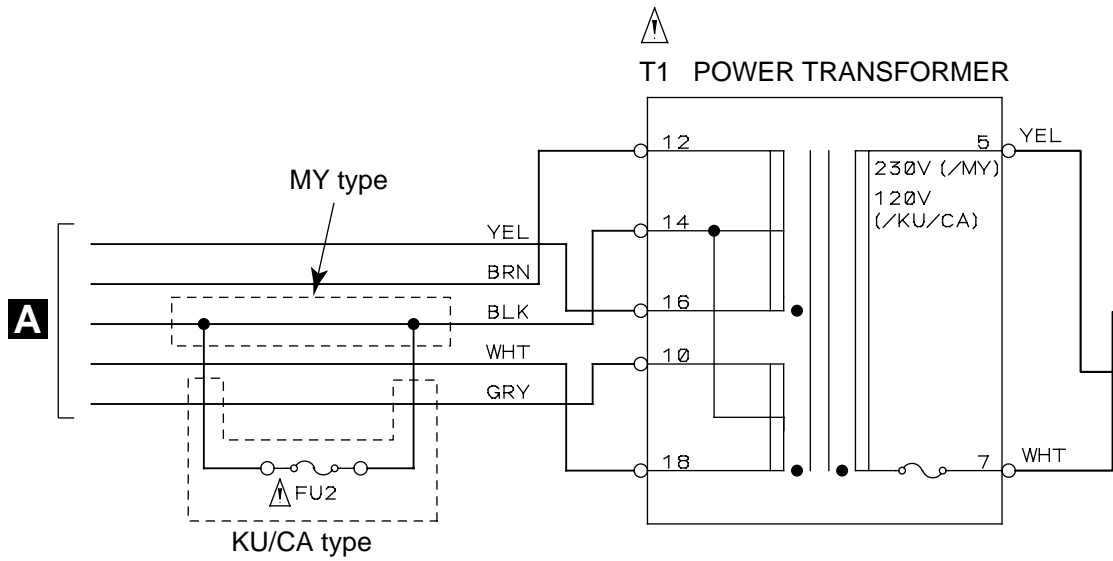

SIDE A

C AC PRIMARY ASSY

D POWER SW ASSY

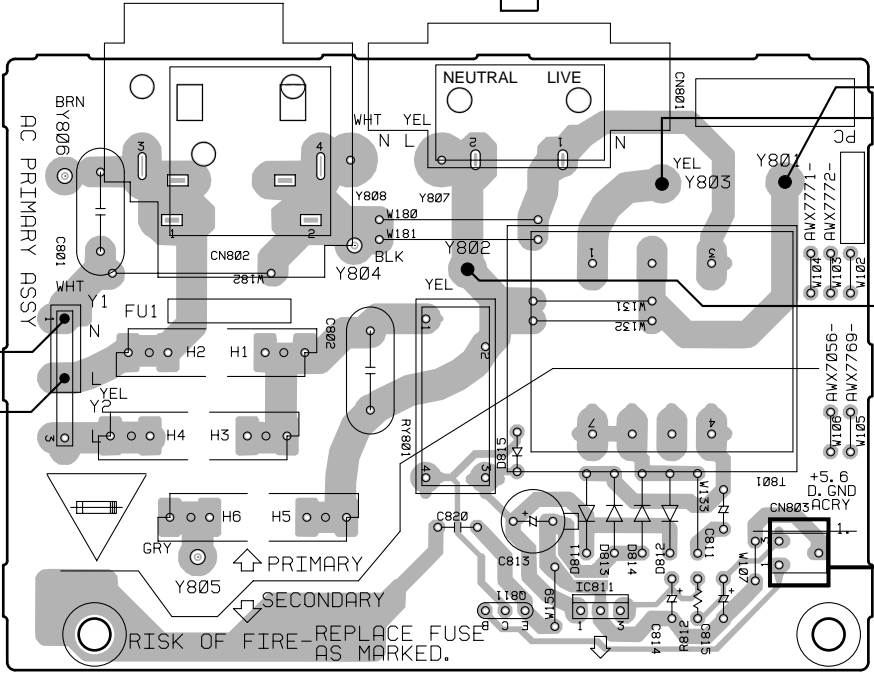

KU/CA type
MY type

A J2

E FRONT R ASSY

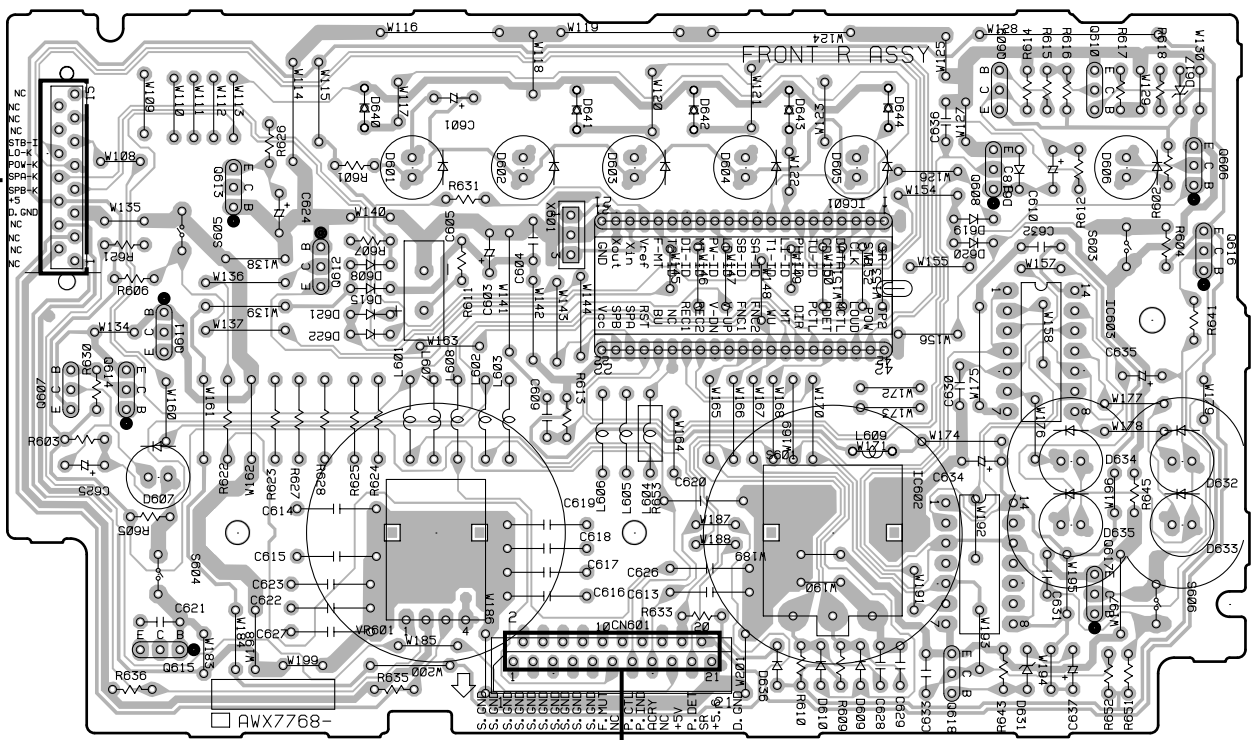

- Q601
- Q602
- Q603
- Q604
- Q605
- Q608
- Q609
- Q610
- Q611
- Q612
- Q613
- Q614
- Q615
- Q616
- Q617
- Q618
- Q619
- Q620
- Q621
- Q622
- Q623
- Q624
- Q625
- Q626
- Q627
- Q628
- Q629
- Q630
- Q631
- Q632
- Q633
- Q634
- Q635
- Q636
- Q637
- Q638
- Q639
- Q640
- Q641
- Q642
- Q643
- Q644
- Q645
- Q646
- Q647
- Q648
- Q649
- Q650
- Q651
- Q652
- Q653
- Q654
- Q655
- Q656
- Q657
- Q658
- Q659
- Q660
- Q661
- Q662
- Q663
- Q664
- Q665
- Q666
- Q667
- Q668
- Q669
- Q670
- Q671
- Q672
- Q673
- Q674
- Q675
- Q676
- Q677
- Q678
- Q679
- Q680
- Q681
- Q682
- Q683
- Q684
- Q685
- Q686
- Q687
- Q688
- Q689
- Q690
- Q691
- Q692
- Q693
- Q694
- Q695
- Q696
- Q697
- Q698
- Q699
- Q700
- Q701
- Q702
- Q703
- Q704
- Q705
- Q706
- Q707
- Q708
- Q709
- Q710
- Q711
- Q712
- Q713
- Q714
- Q715
- Q716
- Q717
- Q718
- Q719
- Q720
- Q721
- Q722
- Q723
- Q724
- Q725
- Q726
- Q727
- Q728
- Q729
- Q730
- Q731
- Q732
- Q733
- Q734
- Q735
- Q736
- Q737
- Q738
- Q739
- Q740
- Q741
- Q742
- Q743
- Q744
- Q745
- Q746
- Q747
- Q748
- Q749
- Q750

A CN202

C D E

5. PCB PARTS LIST

- NOTES :
- Parts marked by “NSP” are generally unavailable because they are not in our Master Spare Parts List.
 - The \triangle mark found on some component parts indicates the importance of the safety factor of the part. Therefore, when replacing, be sure to use parts of identical designation.
 - When ordering resistors, first convert resistance values into code form as shown in the following examples.
- Ex. 1 When there are 2 effective digits (any digit apart from 0), such as 560 ohm and 47k ohm (tolerance is shown by $J = 5\%$, and $K = 10\%$).
- 560 $\Omega \rightarrow 56 \times 10^1 \rightarrow 561$ RD1/4PU $\begin{matrix} \boxed{5} & \boxed{6} & \boxed{1} \end{matrix} J$
 47k $\Omega \rightarrow 47 \times 10^3 \rightarrow 473$ RD1/4PU $\begin{matrix} \boxed{4} & \boxed{7} & \boxed{3} \end{matrix} J$
 0.5 $\Omega \rightarrow R50$ RN2H $\begin{matrix} \boxed{R} & \boxed{5} & \boxed{0} \end{matrix} K$
 1 $\Omega \rightarrow 1R0$ RS1P $\begin{matrix} \boxed{1} & \boxed{R} & \boxed{0} \end{matrix} K$
- Ex. 2 When there are 3 effective digits (such as in high precision metal film resistors).
- 5.62k $\Omega \rightarrow 562 \times 10^1 \rightarrow 5621$ RN1/4PC $\begin{matrix} \boxed{5} & \boxed{6} & \boxed{2} & \boxed{1} \end{matrix} F$

■ LIST OF WHOLE PCB ASSEMBLIES

Mark	Symbol and Description	Part No.		Remarks
		KU/CA type	MY type	
NSP	CONTROL ASSY	AWG7025	AWG7024	
	└ POWER SW ASSY	AWX7057	AWX7057	
	└ FRONT R ASSY	AWX7768	AWX7768	
	└ LED ASSY	AWX7770	AWX7770	
	└ AC PRIMARY ASSY	AWX7771	AWX7056	
NSP	AF COMPLEX ASSY	AWK7679	AWK7678	
	└ FRONT L ASSY	AWX7766	AWX7766	
	└ AF ASSY	AWX7776	AWX7767	

■ CONTRAST OF PCB ASSEMBLIES

C AC PRIMARY Assy

AWX7771 and AWX7056 are constructed the same except for the following:

Mark	Symbol and Description	Part No.		Remarks
		AWX7771	AWX7056	
\triangle	CN801	AKP1122	AKP7005	
\triangle	Y801	ADX7207	Not used	
\triangle	Y803	Not used	ADX7207	

A AF Assy

AWX7776 and AWX7767 are constructed the same except for the following:

Mark	Symbol and Description	Part No.		Remarks
		AWX7776	AWX7767	
\triangle	R1003	Not used	RS3LMF391J	
\triangle	R1004-R1006	Not used	RS3LMF471J	
	Speaker Terminal 4-P	VKE1002	VKE1003	

■ PCB PARTS LIST FOR KU/CA TYPE

Mark	No.	Description	Part No.	Mark	No.	Description	Part No.
D POWER SW ASSY				C AC PRIMARY ASSY			
SWITCHES AND RELAYS				SEMICONDUCTORS			
	△	S901	ASG1035			IC811	NJM78M56FA
						Q811	2SK1132
						D815	HSS104-02
						D811-D814	S5688G
CAPACITORS				TRANSFORMERS			
	△	C901 (3300pF/250V)	ACG7017		△	T801	ATT7009
E FRONT R ASSY				SWITCHES AND RELAYS			
SEMICONDUCTORS					△	RY801	RSR1037
		IC601	PD5637A	CAPACITORS			
		Q609	2SA1048		△	C801, C802 (10000pF/250V)	ACG7020
		Q610	2SC2458			C815 (3.3μF/25V)	ACH7027
		Q612	DTA124ES			C813	CEAT471M25
		Q608	DTC124ES			C814	CEBA470M10
		D608-D610, D615, D618-D622	HSS104-02			C811	CEYANP1R0M50
		D636, D640-D644	HSS104-02	RESISTORS			
		D617	MTZJ4.3A			All Resistors	RD1/4PU□□□J
COILS AND FILTERS				OTHERS			
		L601, L602, L608	LAU221J		△	Y801, Y802 BOARD-IN READ WIRE	ADX7207
CAPACITORS					△	CN801 AC INLET (1P)	AKP1122
		C605	ACH7058			CN803 CONNECTOR (3P)	KPE3
		C610	CEJA2R2M50			H1, H2 FUSE HOLDER	RKR1003
		C603	CEJA470M16	F FRONT L ASSY			
		C604	CKCYF103Z50	SEMICONDUCTORS			
		C613, C620, C626	CKPUYF103Z25			Q702	2SC2458
		C628, C629	CKPUYF473Z16			Q701	DTC124ES
		C609, C636	CKPUYX472M16			D711	HSS104-02
RESISTORS						D701	SLR-343VC (NPQ)
		All Resistors	RD1/4PU□□□J	SWITCHES AND RELAYS			
OTHERS						S701	VSG1009
		CN601 CABLE HOLDER (15P)	51063-1505	CAPACITORS			
		J4 21P FFC CONNECTOR	9604S-21F			C711	CKPUYF473Z16
		X601 JUMPER WIRE	D15A15-125-2651	RESISTORS			
		X601 (4.19MHz)	VSS1014			All Resistors	RD1/4PU□□□J
B LED ASSY				OTHERS			
SEMICONDUCTORS						CN701 CONNECTOR (15P)	KPE15
		D551	BR5064X	RESISTORS			
OTHERS						All Resistors	RD1/4PU□□□J
		J5 CABLE HOLDER (3P)	51063-0305	OTHERS			
		J5 JUMPER WIRE	D15A03-150-2651			All Resistors	RD1/4PU□□□J

M-10X

Mark	No.	Description	Part No.
------	-----	-------------	----------

A AF ASSY SEMICONDUCTORS

	IC451		NJM78M15FA
	IC452		NJM79L15A
	IC301		UPC4570C
	Q152, Q327, Q328, Q409, Q410		2SA1048
	Q321, Q322		2SA970
	Q311–Q314, Q329, Q330		2SA992
	Q452		2SB1238X
	Q309, Q310, Q315, Q316		2SC1845
	Q333, Q334		2SC1845
	Q319, Q320		2SC2240
	Q151, Q317, Q318, Q331, Q332		2SC2458
	Q407, Q408		2SC2458
	Q303, Q304		2SC2878
	Q451		2SC4793
	Q403		2SK1132
	Q401		DTA114ES
	Q251		DTC124ES
	Q411, Q412		DTC143ES
⚠	Q323, Q324		IRF540A
⚠	Q325, Q326		IRF9540A
⚠	D451		D5SBA20
	D1000, D151, D201, D202		HSS104–02
	D301–D306, D309–D314		HSS104–02
	D307, D308		HZS9A1L
	D454		MTZJ33B
	D453		MTZJ36B
	D455		MTZJ4.7A
⚠	D457–D460		S5688G

COILS AND FILTERS

L201, L202, L401, L405, L406	ATX1012
------------------------------	---------

SWITCHES AND RELAYS

RY401	ASR7014
-------	---------

CAPACITORS

C461 (1μF/100V)	ACH1237
C301, C302, C457, C458 (3.3μF/25V)	ACH7027
C451, C452 (15000μ/50V)	ACH7157
C303, C304	CCCSL221K2H
C313–C316	CCCSL330K2H
C408	CEANP470M10
C465, C466	CEAT100M50
C467, C468	CEAT2R2M2A
C405	CEBA2R2M50
C325, C326	CEBAR47M50
C305, C306, C455, C456, C463	CENA100M50
C459, C460	CENA102M50
C317–C320	CENA470M50
C201, C321–C324	CFTYA224J50
C470	CFTYA823J50

Mark	No.	Description	Part No.
------	-----	-------------	----------

C407	CKCYF223Z50
C310, C327, C409, C453, C454	CKCYF473Z50
C307, C308 (220μF/25V)	PCH1128

RESISTORS

⚠ R363, R364	RD1/2PMF152J
⚠ R458, R459	RD1/4LMF2R2J
⚠ R317, R318, R351–R354, R417	RD1/4MUF101J
⚠ R452	RD1/4MUF101J
⚠ R339–R346	RD1/4MUF221J
⚠ R331–R334	RD1/4MUF391J
⚠ R367, R368	RD1/4PMF100J
⚠ R355, R356	RD1/4PMF222J
⚠ R461	RD1/4PMF470J
⚠ R361, R362	RD1/4PMF4R7J
⚠ R462	RD1/4PU100J
R315, R316	RDR1/4PM561J
⚠ R357–R360	RFA1/4PS101J
R349, R350	RN1/4PC2001F
⚠ R451	RS1LMF330J
⚠ R413–R416	RS1LMFR22J
⚠ R453	RS2LMF122J
⚠ R454	RS2LMF182J
VR301, VR302 (2.2 kΩ)	VCP1123
Other Resistors	RD1/4PU□□□J

OTHERS

CABLE HOLDER (3P)	51063–0305
CN202 21P FFC CONNECTOR	9604S–21C
SCREW	ABA–298
SCREW (STEEL)	ABA1007
SCREW	ABA1052
HEAT SINK B	ANH1021
HEAT SINK	ANH1150
J2 JUMPER WIRE	D15A03–075–2651
JA101 PIN JACK (2P)	DKB1045
CN204 4P PLUG	KM200IB4
CN401 CONNECTOR (3P)	KPE3
JA401 JACK	RKN1004
PCB BINDER	VEF1040
SPEAKER TERMINAL 4–P	VKE1002
KN101, KN201, KN301, KN302, KN451	VNF1084
EARTH METAL FITTING	

6. ADJUSTMENT

6.1 IDLE CURRENT ADJUSTMENT

- CAUTION : Heatsinks' (Q323–Q326) DC level is equal to +B or –B.
Don't touch them or you will be electrically shocked.

1. Connect the measuring instrument as Fig.6-1. (R415 or R416)
2. Set VR301 and VR302 to minimum.
3. Set the POWER switch to ON.
4. Adjust VR301 (VR302) so that the voltage between both sides of R415 (R416) becomes $16\text{mV} \pm 1\text{mV}$.
(Within 10 seconds from when the relay is turned ON)
5. Ages for 7 minutes.
6. Adjust VR301 (VR302) so that the voltage between both sides of R415 (R416) becomes $11\text{mV} \pm 1\text{mV}$.

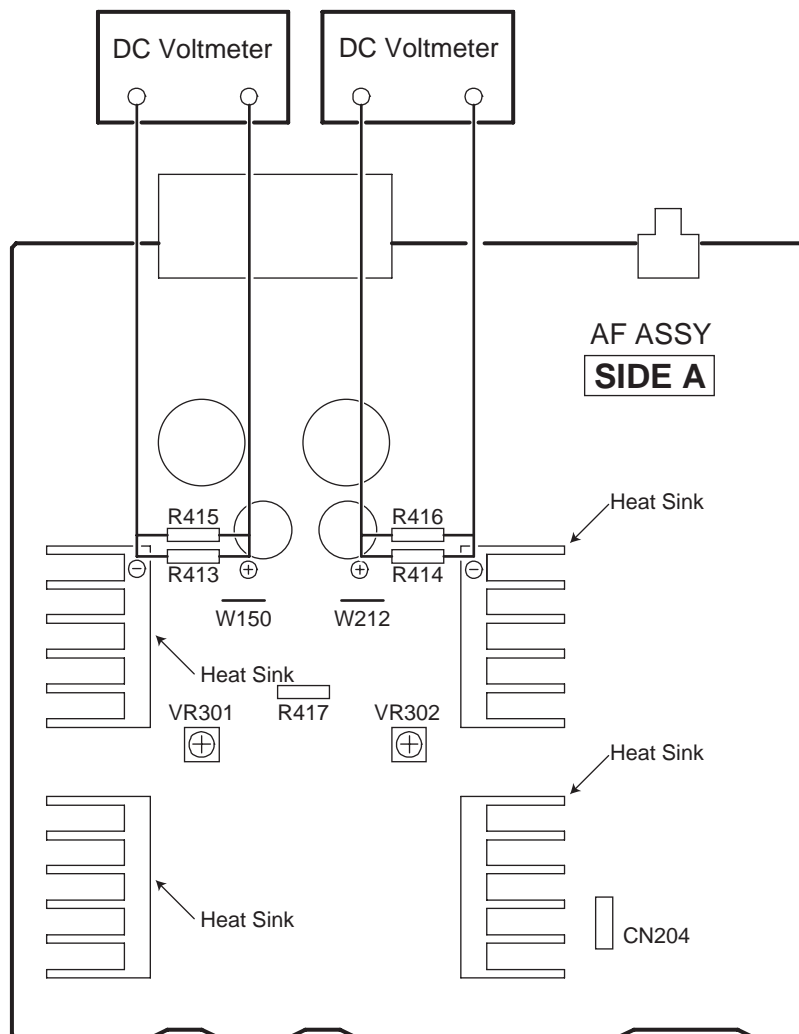

Fig. 6-1 Adjustment Method

7. GENERAL INFORMATION

7.1 IC

■ PD5604A (IC601: FRONT R ASSY)

● Remote Control Amp Microcomputer

● Pin Assignment (Top view)

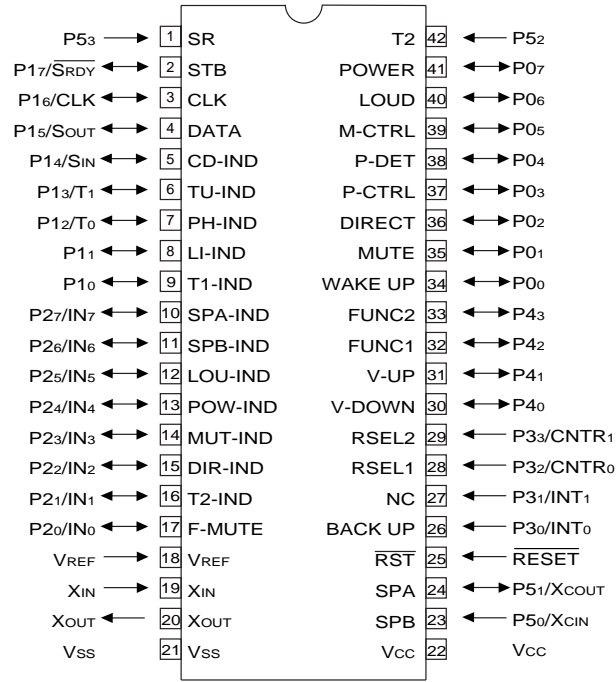

• The information shown in the list is basic information and may not correspond exactly to that shown in the schematic diagrams.

● Pin Function

No.	Pin Name	I/O	Description
1	P53	I	Remote control signal input pin.
2	P17/SRDY	O	TC9163N STB
3	P16/CLK	O	TC9163N CLOCK
4	P15/SOUT	O	TC9163N DATA
5	P14/SIN	O	CD INDICATOR
6	P13/T1	O	TUNER INDICATOR
7	P12/T0	O	PHONO INDICATOR
8	P11	O	LINE INDICATOR
9	P10	O	TAPE1 INDICATOR
10	P27/IN7	O	SPEAKER-A INDICATOR
11	P26/IN6	O	SPEAKER-B INDICATOR
12	P25/IN5	O	LOUDNESS INDICATOR
13	P24/IN4	O	POWER (STAND-BY) INDICATOR
14	P23/IN3	O	MUTE INDICATOR MUTE ON : Repeats H and L every 1 second.
15	P22/IN2	O	DIRECT INDICATOR
16	P21/IN1	O	TAPE2 INDICATOR
17	P20/IN0	O	FUNCTION switch MUTE.
18	VREF	I	Pulls up to 5V.
19	XIN	I	4.19MHz
20	XOUT	O	Ceramic vibrating and connecting terminal.
21	Vss	—	Digital GND.
22	Vcc	—	Power supply +5V.
23	P50/XCIN	I	SPEAKER-B KEY input.

No.	Pin Name	I/O	Description
24	P51/XCOUT	I	SPEAKER-A KEY input.
25	RESET	I	Reset pin.
26	P30/INT0	I	BACK UP detection pin. interrupt specification.
27	P31/INT1	O	Not used.
28	P32/CNTR0	I	REC selector input 1.
29	P33/CNTR1	I	REC selector input 2. interrupt specification.
30	P40	O	Volume DOWN data output.
31	P41	O	Volume UP data output.
32	P42	I	FUNCTION selector input 1.
33	P43	I	FUNCTION selector input 2.
34	P00	I	WAKE UP input. Key on wake up specification.
35	P01	I	MUTE KEY input. Key on wake up specification.
36	P02	I	DIRECT KEY input. Key on wake up specification.
37	P03	O	Protection control pin.
38	P04	I	Output error detection pin
39	P05	O	MUTING control pin.
40	P06	I	LOUDNESS KEY input. Key on wake up specification.
41	P07	I	POWER KEY input. Key on wake up specification.
42	P52	I	TAPE2 KEY input.

7.2 CIRCUIT DESCRIPTION

Use a wide range linear circuit of A-607R series for voltage stage, and use HEX POWER MOS-FET for output stage.

- This circuitry eliminates source resistance, and reduce power loss in large amount with super low capacity resistor of output stage device and realize the low generation of heat, low source voltage.
- This circuitry eliminates source resistance and listing electric coil, and achieve the damping factor that is flat with band (20Hz - 20kHz).

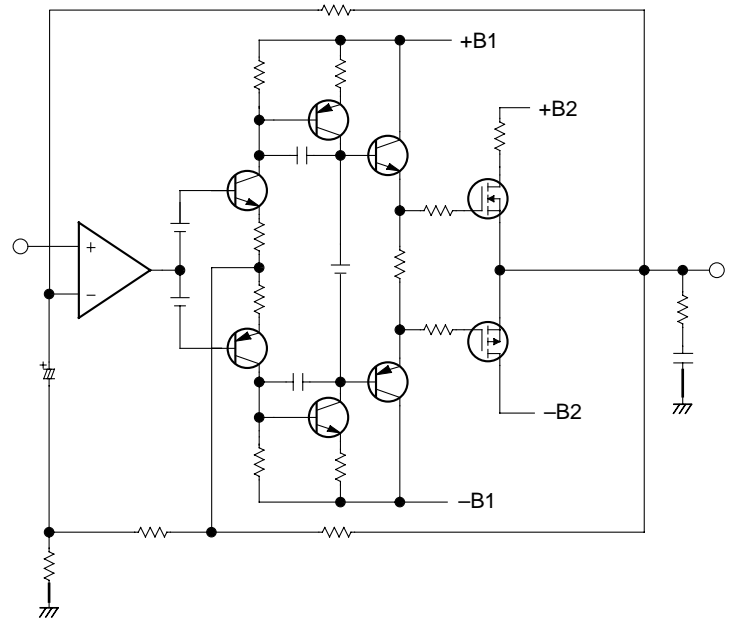

8. PANEL FACILITIES AND SPECIFICATIONS

■ PANEL FACILITIES (The illustration shows the KU/CA type.)

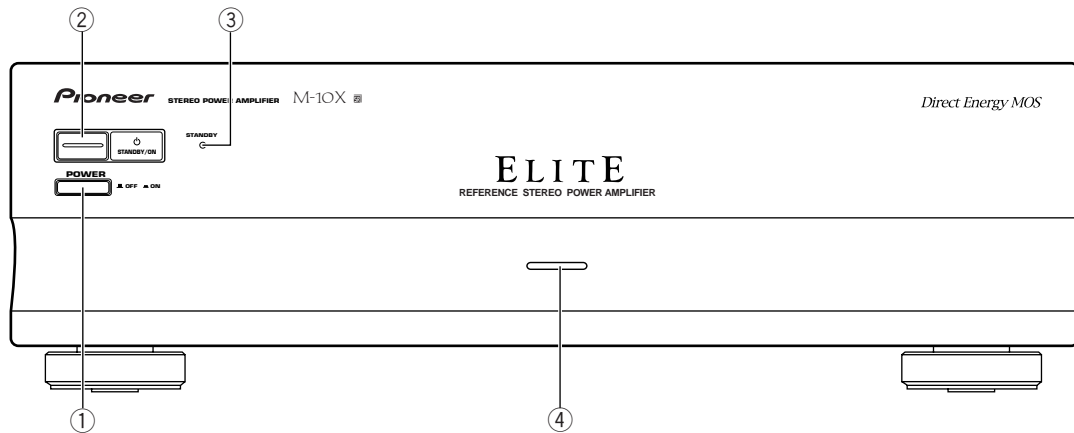

- ① **Main power (■ OFF/ ■ ON) button**
If the button is OFF (■), the power of the amplifier is shut off and the STANDBY/ON button on the amplifier does not function.
Pressing the main power button will turn the amplifier ON (■).
- ② **STANDBY/ON button**
Press to switch the amplifier ON or into STANDBY mode.
- ③ **STANDBY indicator**
Lights when the amplifier is in STANDBY mode. (Please note that this amplifier consumes a small amount of power (1 W) during the standby mode.)
- ④ **POWER indicator**
Lights when the power is switched on.

NOTE:

The protection function will operate in case of internal amplifier malfunction or in case of external causes such as static electricity or speaker terminal short circuits. When the protection function operates, the POWER indicator flashes, and the unit goes out into standby mode.
If this occurs, check the speaker terminals and speaker cords to make sure they are not shorted, then press the STANDBY/ON button to turn on the unit.
If the protection function then operates again, unplug the power cord and contact a service center.

■ SPECIFICATIONS

● For KU/CA Type

Amplifier Section

Continuous average power output of 100 watts* per channel, min., at 4 ohms, from 20 Hz to 20,000 Hz with no more than 0.2 % total harmonic distortion.**

Puissance de sortie moyenne continue de 100 watts* par canal, minimum, sous 4 ohms, de 20 Hz à 20.000 Hz avec distorsion harmonique totale inférieure à 0,2 %.**

Continuous power output
(both channels driven at 20 Hz to 20 kHz)**

T.H.D. 0.2 %, 4 Ω	100 W + 100 W
T.H.D. 0.2 %, 8 Ω	70 W + 70 W

Total harmonic distortion**

20 Hz to 20 kHz, 8 Ω	0.05 %
----------------------------	--------

Input sensitivity/ impedance 700 mV/ 47 kΩ
 Frequency response 5 Hz to 100 kHz $^{+0}_{-3}$ dB
 Signal-to-Noise ratio (IHF A network, short circuit)
 118 dB

Power Supply/ Miscellaneous

Power requirements AC 120 Volts, 60 Hz
 Power consumption 198 W
 Power consumption in standby mode 1 W
 Consommation (en veille) 1 W
 Dimensions 420 (W) × 319 (D) × 128 (H) mm
 (including knobs and other protruding parts)
 Weight (without package) 7.6 kg

Accessories

Operating instructions 1
 Power cord (Rated current 7 A) 1
 Remote control cord 1
 Warranty card 1

NOTE:

Specifications and design subject to possible modification without notice, due to improvements.

* Measured pursuant to the Federal Trade Commission's Trade Regulation rule on Power Output Claims for Amplifiers.

** Measured by Audio Spectrum Analyzer.

● For MY Type

Amplifier Section

Continuous power output
(both channels driven at 20 Hz to 20 kHz)*

T.H.D. 0.09 %, 4 Ω	90 W + 90 W
T.H.D. 0.05 %, 8 Ω	60 W + 60 W

DIN Continuous power output (both channels driven at 1 kHz)

T.H.D. 1.0 %, 4 Ω	120 W + 120 W
T.H.D. 1.0 %, 8 Ω	75 W + 75 W

Total harmonic distortion*

20 Hz to 20 kHz, 8 Ω	0.05 %
----------------------------	--------

•Power output specification is for when power supply is 230V.

Input sensitivity/ impedance 700 mV/ 47 kΩ
 Frequency response 5 Hz to 100 kHz $^{+0}_{-3}$ dB
 Signal-to-Noise ratio (IHF A network, short circuit)
 118 dB

Power Supply/ Miscellaneous

Power requirements AC 220 – 230 Volts, 50/ 60 Hz
 Power consumption 220 W
 Power Consumption in standby mode 1 W
 Dimensions 420 (W) × 319 (D) × 128 (H) mm
 (including knobs and other protruding parts)
 Weight (without package) 7.6 kg

Accessories

Operating instructions 1
 Power cord (Rated current 2.5 A) 1
 Remote control cord 1
 Warranty card 1

NOTE:

Specifications and design subject to possible modification without notice, due to improvements.

* Measured by Audio Spectrum Analyzer.