

 **PIONEER®**

Service Manual

CIRCUIT DESCRIPTIONS



The photo shows the model PD-9010X[BK].

**ORDER NO.
ARP-883-0**

COMPACT DISC PLAYER

PD-9010X(BK)

PD-7010(BK)

PD-5010(BK)

CONTENTS

1. IC INFORMATION	2
2. BLOCK DIAGRAM	13
3. CIRCUIT OUTLINE	
3.1 SERVO SECTION	15
3.2 CIRCUIT DESCRIPTION	23
3.3 OPERATION	
• PD-5010	39
• PD-7010, PD-9010X	44

PIONEER ELECTRONIC CORPORATION 4-1, Meguro 1-Chome, Meguro-ku, Tokyo 153, Japan
PIONEER ELECTRONICS SERVICE INC. P.O. Box 1760, Long Beach, California 90801 U.S.A. TEL: (213) 420-5700
PIONEER ELECTRONIC (EUROPE) N.V. Keetberglaan 1, 2740 Beveren, Belgium TEL: 03/775-28-08
PIONEER ELECTRONICS AUSTRALIA PTY. LTD. 178-184 Boundary Road, Braeside, Victoria 3195, Australia
TEL: (03) 580-9911

FZ © APR. 1986 Printed in Japan

1. IC INFORMATION

- CX20109

- Pin Name

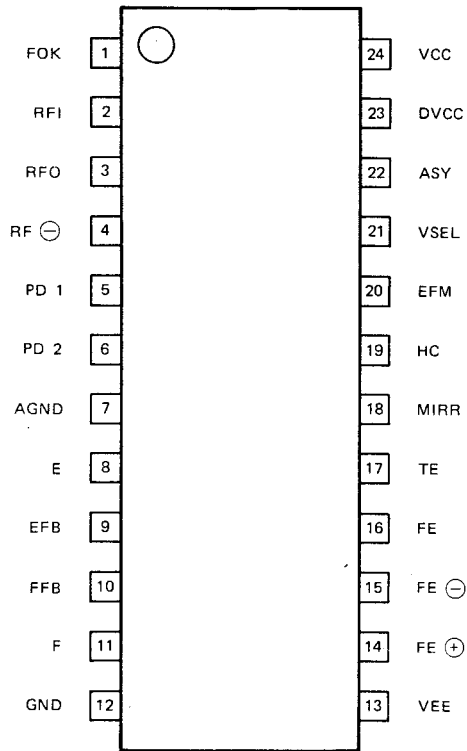

- Block Diagram

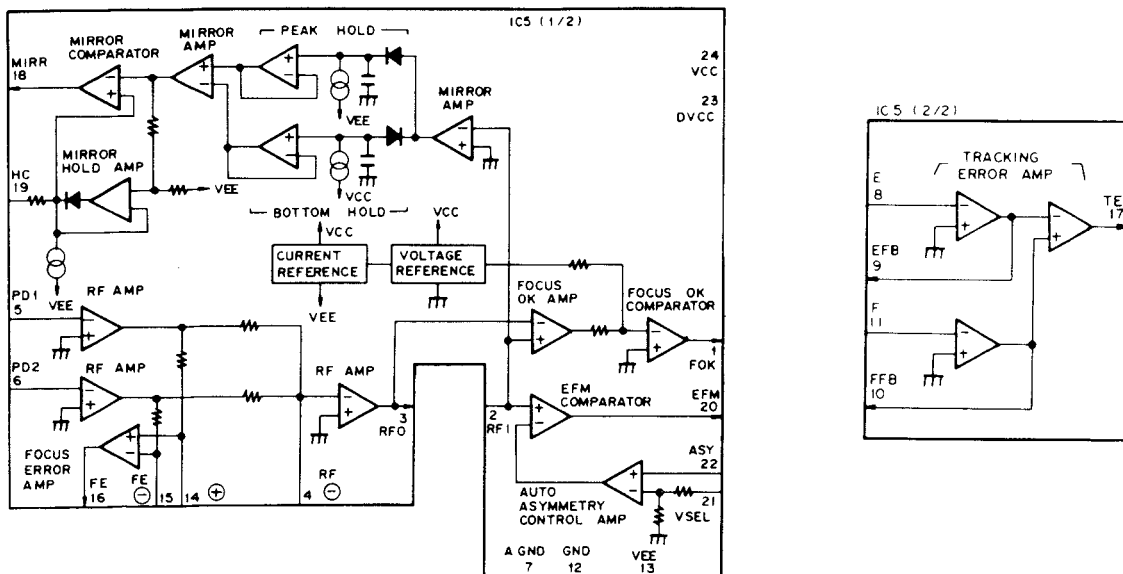

• Pin Functions

Pin No.	Pin name	I/O	Function
1	FOK	O	Output of Focusing Servo Allowed, Active at Comparator Output "H". Connects Load Resistor (PNP Open Collector).
2	RFI	I	Inputs RF Summing Amp Output by a C coupling.
3	RFO	O	RF Summing Amp Output, Eve Pattern Test Point.
4	RF -	I	RF Summing Amp Inverted Input, Connects Feedback CR to ③ - ④.
5	PD 1	I	RF I-V Amp (1) Inverted Input, Current Input by connection to PIN Diodes B + D.
6	PD 2	I	RF I-V Amp (2) Inverted Input, Current Input by connection to PIN Diodes A + C.
7	AGND	-	Small Signal Analog Channel Ground
8	E	I	E I-V Amp Inverted Input, Current Input by connection to PIN Diode E.
9	EFB	O	E I-V Amp Output Connects Feedback CR to ⑧ - ⑨.
10	FFB	O	F I-V Amp Output Connects Feedback CR to ⑩ - ⑪.
11	F	I	F I-V Amp Inverted Input, Current Input by connection to PIN Diode F.
12	GND	-	GND
13	V _{EE}	-	Negative Power Supply
14	FE ⊕	I	Focus Error Amp Non-Inverted Input, Connects CR for Low Pass Filter.
15	FE ⊖	I	Focus Error Amp Inverted Input
16	FE	O	Focus Error Amp Output, Connects Feedback CR to ⑮ - ⑯
17	TE	O	Tracking Error Amp Output
18	MIRR	O	Mirror Comparator Output (active at "H"), Connects Load Resistor (PNP Open Collector).
19	HC	I	Mirror Hold Capacitor connecting pin
20	EFM	O	EFM Comparator Output
21	VSEL	I	Auto-Asymmetry Control Amp Reference Input Level setting pin; V _{cc} when under ±5V Power Supply, GND when under +10V Power Supply
22	ASY	I	Auto-Asymmetry Control Input
23	DV _{cc}	-	Positive Power Supply for EFM Comparator
24	V _{cc}	-	Positive Power Supply

- CX20108

- Pin Name

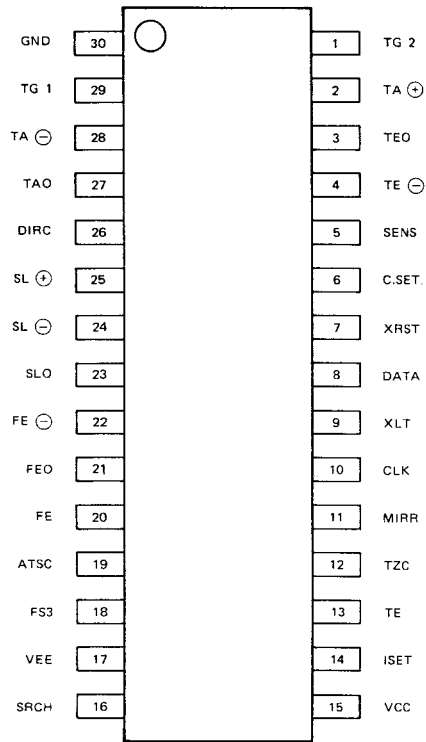

- Block Diagram

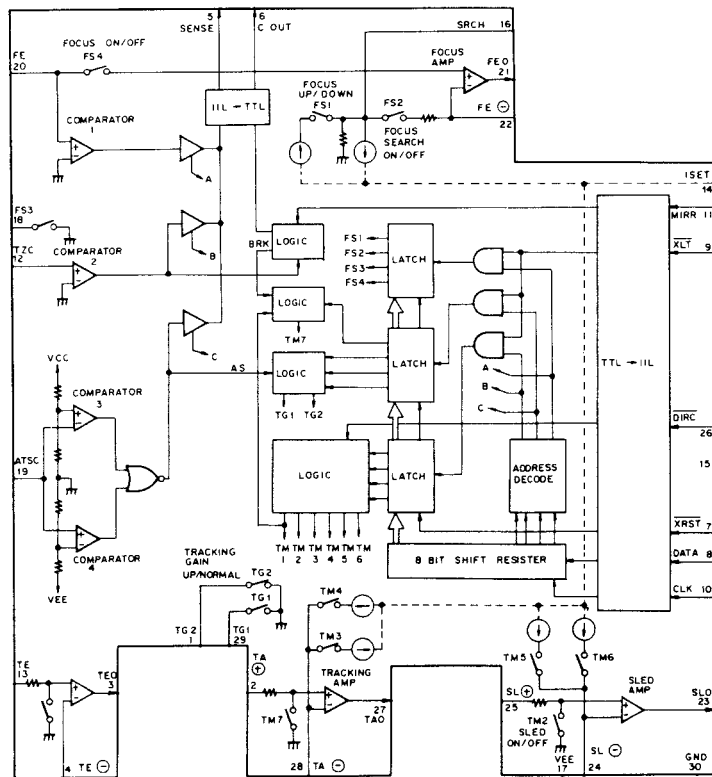

• Pin Functions

Pin No.	Pin name	I/O	Function																
1	TG2		Tracking amplifier gain-switching pin; either open or at the GND level.																
2	TA ⊕		Non-inverted input of operational amplifier 2.																
3	TEO		Output of operational amplifier 4.																
4	TE ⊖		Inverted input of operational amplifier 4.																
5	SENSE	O	Output indicating the internal status of SSP determined by ADDRESS sent from the CPU to SSP (varies with the value of ADDRESS in the internal serial register (Note 1)).																
<table border="1"> <thead> <tr> <th>COMMAND</th> <th>ADDRESS D7, D6, D5, D4</th> <th>SENS</th> <th>EXPLANATION</th> </tr> </thead> <tbody> <tr> <td>FOCUS CONTROL</td> <td>φφφφ</td> <td>FZC</td> <td>When focus zero cross or focus error voltage is over 0 V, use high level focus pull operations.</td> </tr> <tr> <td>TRACKING CONTROL</td> <td>φφφI</td> <td>AS</td> <td>When ⑱ ATSC input level exceeds the window comparator level, then 1.</td> </tr> <tr> <td>TRACKING MODE</td> <td>φφIφ</td> <td>TZC</td> <td>Tracking zero cross Plus or minus tracking error decision output Use for one track jump. Adjust DIRC to LOW at the time of FWD JUMP TZC search or REV JUMP TZC search.</td> </tr> </tbody> </table>				COMMAND	ADDRESS D7, D6, D5, D4	SENS	EXPLANATION	FOCUS CONTROL	φφφφ	FZC	When focus zero cross or focus error voltage is over 0 V, use high level focus pull operations.	TRACKING CONTROL	φφφI	AS	When ⑱ ATSC input level exceeds the window comparator level, then 1.	TRACKING MODE	φφIφ	TZC	Tracking zero cross Plus or minus tracking error decision output Use for one track jump. Adjust DIRC to LOW at the time of FWD JUMP TZC search or REV JUMP TZC search.
COMMAND	ADDRESS D7, D6, D5, D4	SENS	EXPLANATION																
FOCUS CONTROL	φφφφ	FZC	When focus zero cross or focus error voltage is over 0 V, use high level focus pull operations.																
TRACKING CONTROL	φφφI	AS	When ⑱ ATSC input level exceeds the window comparator level, then 1.																
TRACKING MODE	φφIφ	TZC	Tracking zero cross Plus or minus tracking error decision output Use for one track jump. Adjust DIRC to LOW at the time of FWD JUMP TZC search or REV JUMP TZC search.																
6	C.SET	O	Track-counting signal output at the time of high-speed access.																
7	XRST	I	Clears all internal registers when the CPU-to-SSP level is Low; connected to CPU RESET (Note2).																
8	DATA	I	CPU-to-SSP serial data transfer; input from LSB; D0 to D7.																
9	XLT	I	Latching of CPU-to-SSP serial data (transfers data in the internal serial shift register to each address-decoded latch); transfers data at the Low level; the level must be changed to High immediately at the completion of transfer as no edge trigger method is applied.																
10	CLK	I	CPU-to-SSP serial data transfer clock pulses; data is fetched at the negative-going edge; the level must be H before and after transfer.																
11	MIRR	I	Mirror signal input from the RF amplifier.																
12	TZC		Tracking-error signal input by capacitor coupling; The time constant is determined according to the condition of one-track jump, but is normally 2 kHz.																
13	TE		Tracking error signal input																
14	ISET		For setting current to determine the focus search voltage, tracking jump voltage, and sled-feeding voltage.																
15	Vcc		Power supply pin; normally at +5V.																

• Pin Functions

Pin No.	Pin name	I/O	Function
1	FSW	O	Spindle motor output filter time constant select output.
2	MON	O	Spindle motor ON/OFF control output.
3	MDP	O	Spindle motor drive output. Rough control during CLV-S mode and phase control during CLV-P mode.
4	MDS	O	Spindle motor drive output. Speed control during CLV-P mode.
5	EFM	I	EFM signal input from RF amp.
6	ASY	O	EFM signal slice level control output.
7	MIRR	I	MIRROR input from RF amp.
8	VCOO	O	VCO output. When locked to EFM signal, $f = 8.6432$ MHz.
9	VCOI	I	VCO input.
10	TEST	I	(0 V)
11	PDO	O	EFM signal and VCO/2 phase comparison output.
12	VSS	—	GND (0 V)
13	CLK	I	Serial data transfer clock input from CPU. Data latching clock rise edge.
14	XLT	I	Latch input from CPU. Latching 8-bit shift register data (serial data from CPU) to respective registers.
15	DATA	I	Serial data input from CPU.
16	XP.ST	I	System reset input. Reset at L.
17	C _{NIN}	I	Tracking pulse input.
18	SENS	O	Outputting internal state according to address.
19	MUTG	I	Muting input with internal register A ATT _M at L, normal state when MUTG is low and no sound when it is high.
20	CRCF	O	Output the CRC result of subcode Q
21	EXCK	I	Clock input for subcode serial output.
22	SBSO	O	Subcode serial output.
23	SUBQ	O	Subcode Q output.
24	SCOR	O	Subcode sync S0 + S1 output.
25	WFCX	O	Write frame clock output. When frame synch is locked, $f = 7.35$ KHz.
26	RFCX	O	Read frame clock output. Crystal system 7.35 KHz.
27	GTOP	O	Frame sync protection state display output.
28	GFS	O	Frame sync lock state display output.
29	DB08	I/O	External RAM data terminal. DATA8 (MSB)
30	DB07	I/O	External RAM data terminal. DATA7
31	DB06	I/O	External RAM data terminal. DATA6
32	DB05	I/O	External RAM data terminal. DATA5
33	VDD	—	Power supply (+5 V)
34	DB04	I/O	External RAM data terminal. DATA4
35	DB03	I/O	External RAM data terminal. DATA3
36	DB02	I/O	External RAM data terminal. DATA2
37	DB01	I/O	External RAM data terminal. DATA1 (LSB)
38	RA01	O	External RAM address output. ADDR01 (LSB)
39	RA02	O	External RAM address output. ADDR02
40	RA03	O	External RAM address output. ADDR03
41	RA04	O	External RAM address output. ADDR04

Pin No.	Pin name	I/O	Function
16	SRCH		Connected to the capacitor which determines the time constant of charging and discharging curves for focus search.
17	Vee		Power supply pin; normally at $-5V$.
18	FS3		Focus amplifier gain-switching pin; either open or at the GND level.
19	ATSC		Input of data indicating that mechanical impact has been applied to the player; inputs tracking errors via BPF in simplified operation; should be connected to GND when not in use.
20	FE		Focus error signal input.
21	FEO		Output of operational amplifier 1.
22	FE \ominus		Inverted input of operational amplifier 1.
23	SLO		Output of operational amplifier 3.
24	SL \ominus		Inverted input of operational amplifier 3.
25	SL \oplus		Non-inverted input of operational amplifier 3.
26	DIRC	I	Used at the time of one-track jump; normally High; inverts the direction of track-Jump pulses at the Low level; establishes the normal tracking mode when set to go High immediately after the inversion; goes Low for a specified period at the detection of positive- and negative-going edges of TZC.
27	TAO		Output of operational amplifier 2.
28	TA \ominus		Inverted output of operational amplifier 2.
29	TG1		Tracking amplifier gain-switching pin; either open or at the GND level.
30	GND		GND pin of the IC.

Note: Functions above describe the applications in typical examples only.

- CX23035

- Pin Name

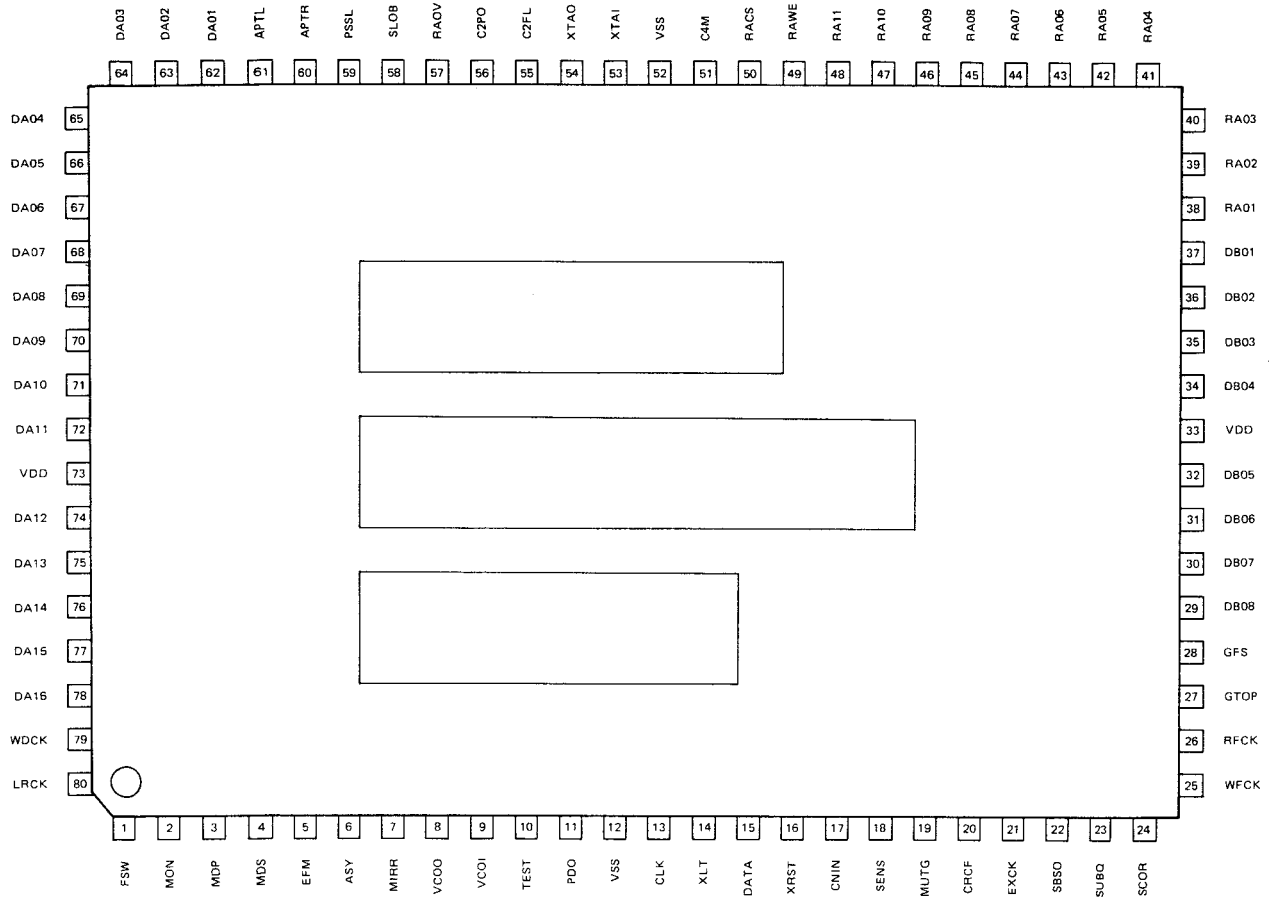

- Block Diagram

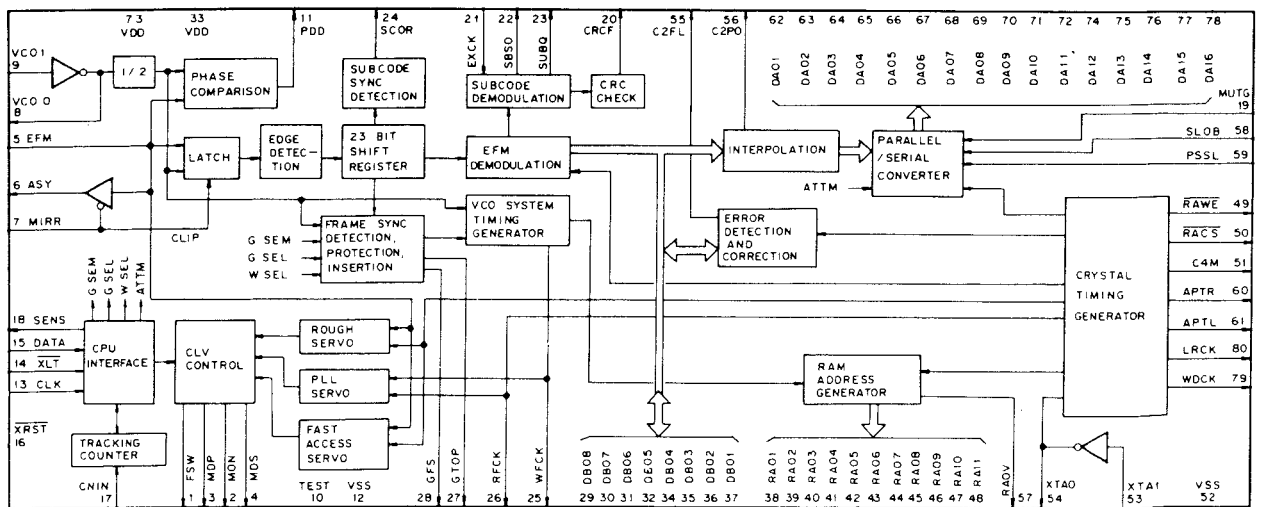

Pin No.	Pin name	I/O	Function
42	RA05	O	External RAM address output. ADDR05
43	RA06	O	External RAM address output. ADDR06
44	RA07	O	External RAM address output. ADDR07
45	RA08	O	External RAM address output. ADDR08
46	RA09	O	External RAM address output. ADDR09
47	RA10	O	External RAM address output. ADDR10
48	RA11	O	External RAM address output. ADDR11 (MSB)
49	RAME	O	Write enable signal output to external RAM (active when low).
50	RACS	O	Chip select signal output to external RAM (active when low).
51	C _{AM}	O	Crystal 1/2 frequency division output. f = 4.2336 MHz.
52	V _{SS}	—	GND (0 V)
53	XTAL	I	Crystal oscillation circuit input. f = 8.4672 MHz.
54	XTAO	O	Crystal oscillation circuit output. f = 8.4672 MHz.
55	C2FL	O	Corrects state output. When currently corrected C2 series is incorrectable, it becomes high.
56	C2PO	O	C2 pointer display output. Synchronized to audio data output.
57	RAOV	O	±4 frame jitter absorption RAM overflow and underflow display output.
58	SLOB	I	Audio data output code select input. Two's complement output when low, offset binary output when high.
59	PSSL	I	Audio data output mode select input. Serial output when low, parallel output when high.
60	APTR	O	Aperture compensation control output. High with R-ch.
61	APTL	O	Aperture compensation control output. High with L-ch.
62	DA01	O	DA01 (parallel audio data LSB) output when PSSL is H. C1F1 output when PSSL is L.
63	DA02	O	DA02 output when PSSL is high, C1F2 output when PSSL is low.
64	DA03	O	DA03 output when PSSL is high, C2F1 output when PSSL is low.
65	DA04	O	DA04 output when PSSL is high, C2F2 output when PSSL is low.
66	DA05	O	DA05 output when PSSL is high, UGFS output when PSSL is low.
67	DA06	O	DA06 output when PSSL is high, WFCK output when PSSL is low.
68	DA07	O	DA07 output when PSSL is high, FCKV output when PSSL is low.
69	DA08	O	DA08 output when PSSL is high, FCKX output when PSSL is low.
70	DA09	O	DA09 output when PSSL is high, PLCK output when PSSL is low.
71	DA10	O	DA10 output when PSSL is high, LRCK output when PSSL is low.
72	DA11	O	DA11 output when PSSL is high, C4LR output when PSSL is low.
73	V _{DD}	—	Power supply (+5 V).
74	DA12	O	DA12 output when PSSL is high, DENL when PSSL is low.
75	DA13	O	DA13 output when PSSL is high, DENR when PSSL is low.
76	DA14	O	DA14 output when PSSL is high, C210 when PSSL is low.
77	DA15	O	DA15 output when PSSL is high, C210 when PSSL is low.
78	DA16	O	DA16 (parallel audio data MSB) output when PSSL is high, DATA output when PSSL is low.
79	WDCX	O	88.2 KHz strobe signal output.
80	LRCX	O	44.1 KHz strobe signal output.

●CX23034

● Pin Name

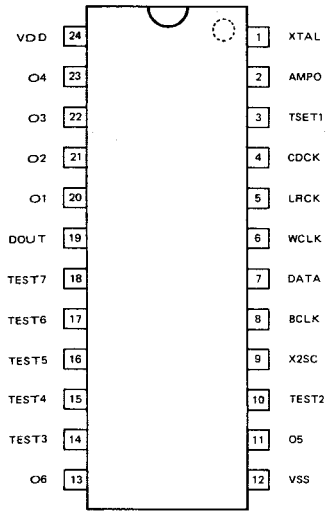

● Block Diagram

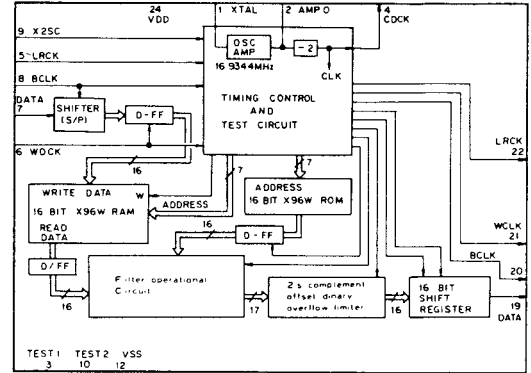

● Pin Functions

Pin No.	Pin name	I/O	Function
1	XTAL	I	Input for crystal oscillator (16.9344 MHz)
2	AMPO	O	Output for crystal oscillator (16.9344 MHz)
3	TSET1	I	Input for testing (Normally connected to Vss)
4	CDCK	O	Clock output (8.4672 MHz)
5	LRCK	I	44.1 kHz strobe input
6	WCLK	I	88.2 kHz strobe input
7	DATA	I	Serial data input (Two's complement, MSB first)
8	BCLK	I	Bit clock input (input for serial data)
9	X2SC	I	Input for output format selection (High offset binary, low two's complement)
10	TEST2	I	Input for test (normally connected to Vss)
11	O5	O	Timing signal
12	Vss	—	GND pin (0V)
13	O6	O	Timing signal
14	TEST3	O	Test data output (normally open)
15	TEST4	O	Test data output (normally open)
16	TEST5	O	Test data output (normally open)
17	TEST6	O	Test data output (normally open)
18	TEST7	O	Test data output (normally open)
19	DOUT	O	Serial data output (MSB first)
20	O1	O	Timing signal
21	O2	O	Timing signal
22	O3	O	Timing signal
23	O4	O	Timing signal
24	VDD	—	Power supply pin (+5V)

2. BLOCK DIAGRAM

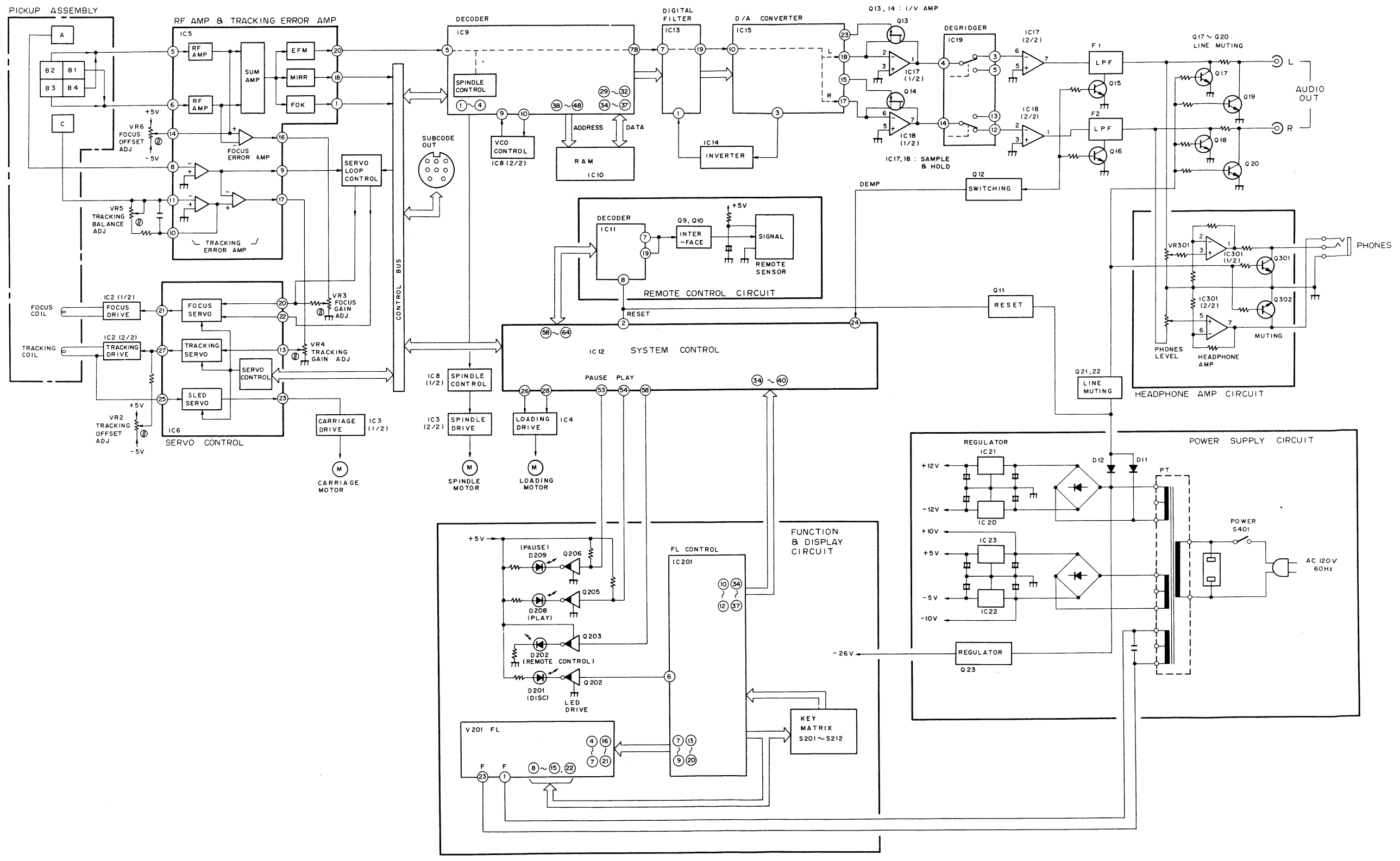

● CX20152

● Pin Name

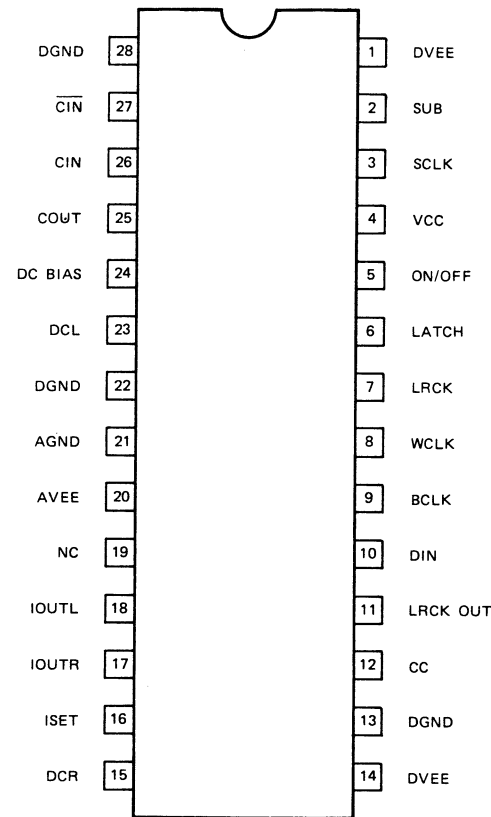

● Block Diagram

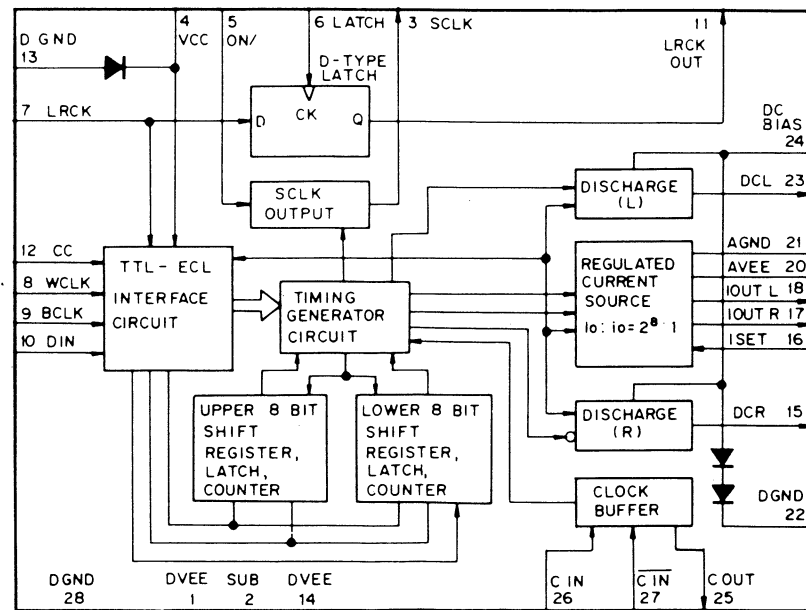

● Pin Functions

Pin No.	Pin name	Function
1	DVEE	Digital system power supply terminal: -5V
2	SUB	IC substrate: Be sure to connect to Pin 1.
3	SCLK	System clock output terminal
4	VCC	Digital system power supply terminal: +5V
5	ON/OFF	Terminal to determine the system clock on/of
6	LATCH	Clock terminal of D type latch
7	LRCK	LRCK input terminal
8	WCLK	WCLK input terminal
9	BCLK	BCLK input terminal
10	DIN	DIN (data input terminal)
11	LRCKOUT	LRCK output terminal
12	CC	CC input terminal: MSB first
13	DGND	Digital system ground terminal
14	DVEE	Digital system power supply terminal: -5V
15	DCR	Right channel discharge drive signal output terminal
16	ISET	Integration current setting terminal
17	IOUTR	Right channel current output terminal
18	IOUTL	Left channel current output terminal
19	NC	No connection
20	AVEE	Analog system power supply terminal
21	AGND	Analog system ground terminal
22	DGND	Digital system ground terminal
23	DCL	Left channel discharge drive signal output terminal
24	DCBIAS	Discharge circuit bias terminal
25	COUT	Clock generator output terminal
26	CIN	Clock generator positive input terminal
27	CIN	Clock generator negative input terminal
28	DGND	Digital system ground terminal

3. CIRCUIT DIAGRAM

3.1 SERVO SECTION

Servo control in this CD player is performed using two LSIs (CX20109, CX20108) configured around a system control CPU. Each LSI is connected to the CPU by a data bus. All control is conducted using the serial data from the CPU. The data pattern will be described later.

The primary servo control systems of the CD player are listed below.

1. Focus servo
2. Tracking servo
3. Spindle servo

An explanation of these three systems follows.

3.1.1 The Focus Servo Loop

Purpose:

To control the distance between lens and disk so as to keep the laser beam focused on the pits on the disc surface.

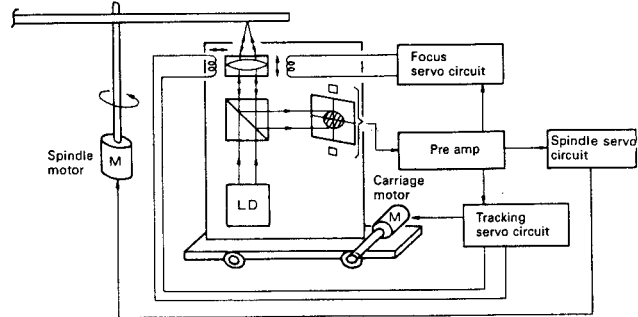

Fig. 3-1 Focus servo loop circuit

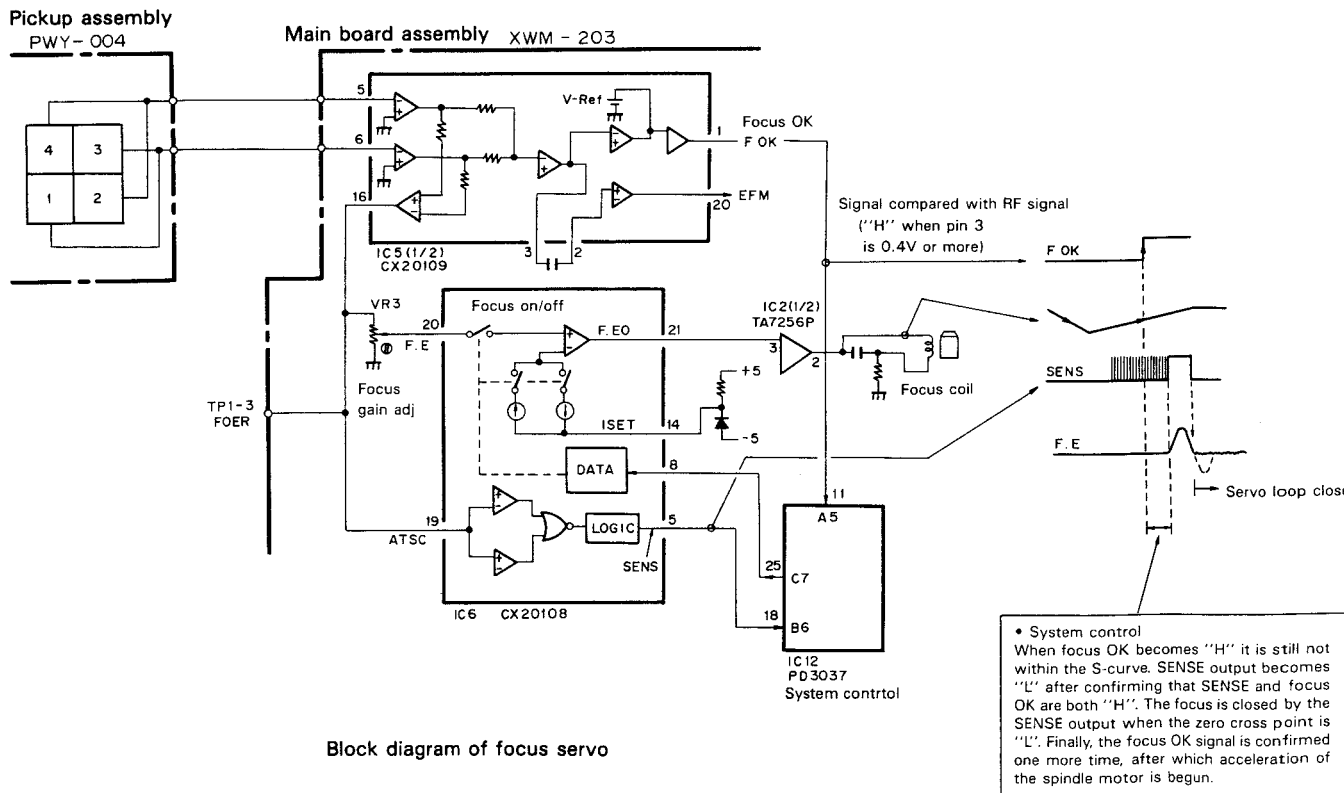

Fig. 3-2

FOCUS SERVO

When the focus servo does not lock, focus-in is performed one more time. If the result is still unsatisfactory, focus-in operation is stopped.

START-UP CONDITIONS

1. Disc is loaded.
2. Laser diode is emitting a beam.
3. Focus start-up data is being output from the system control PD3037 (IC?).

SUMMARY OF OPERATION

1. Lens is forcibly moved down and then up (internally processed by CX20108 (IC6)).
 2. The related signals are as follows when the zero cross is located during this lens movement:
 - a) SENS output: Goes to focus lock after generation.*1
 - b) Focus OK output (H level): If system control does not confirm the existence of this output, focus lock is not performed. Furthermore, this output is checked again before proceeding to the next step.
 - c) Focus error signal: Generates zero cross (s-curve).
- *1: When zerko cross is detected using the SENS output, the disc set LED lights and the focus servo loop is closed.
3. The next step is acceleration of the spindle motor and tracking.
Refer to the focus servo block diagram.

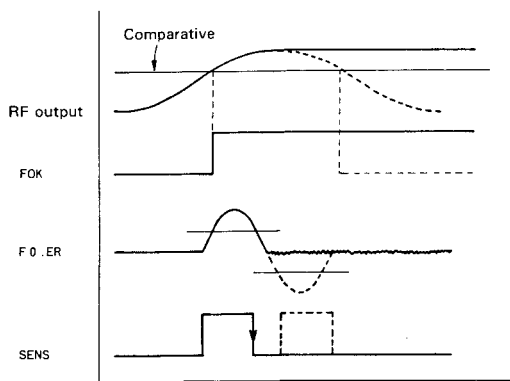
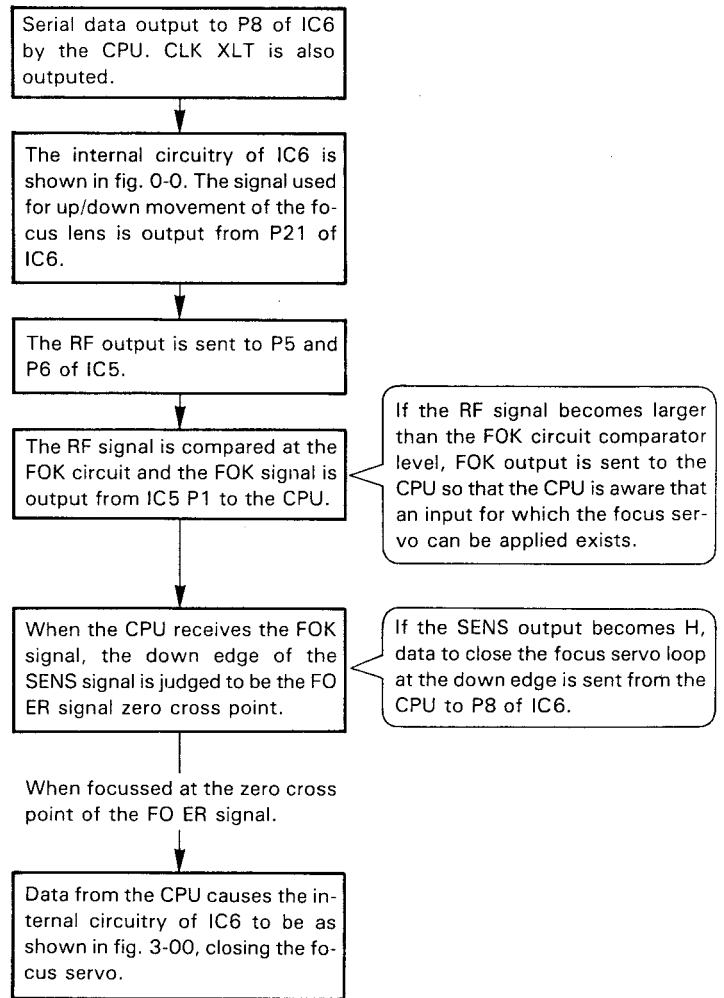

Fig. 3-3

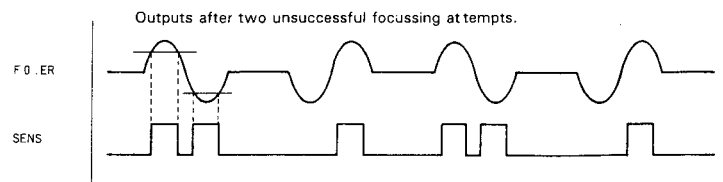

Fig. 3-4

Summary of Operation

1. When the FOK signal is confirmed by the system control, acceleration of the spindle motor begins and the "start tracking" data are output.
2. The RF and TE signals are obtained from the pickup. The RF signal is then used to produce the MIRR signal. When RF exists, this signal is "L"; when RF does not exist, the MIRR signal is "H". This provides the indispensable data needed to close tracking. (The MIRR signal is also used for judgment of the outer edge mirror and track count during search and jump.)
3. The system control indirectly knows that tracking has begun because of (1) when the RF signal exists, the MIRR signal is "L" and (2) the GFS signal (see the spindle servo explanation).
4. The next step is spindle lock. Refer to the tracking servo block diagram for details.

3.1.3 Spindle Servo Loop

Purpose:

To control disc rotation speed so that constant linear velocity (CLV) is maintained. (Disc speed is gradually lowered as the pickup moves from the inside of a disc to the outside as the disc is played.)

Standard:

The servo controls the spindle rotation speed to maintain the frame synch encoded in the disc pits at 7.35 kHz.

Start-up conditions

1. Proper focusing (FOK signal)

Summary of Spindle Lock Operations

1. When the focus OK signal is confirmed by the system control, spindle acceleration is triggered for an interval of .300m sec.
2. When tracking (with ON TRACK) has begun and the PLL is locked, CX23035 generates an "H" GFS signal.
3. This GFS signal is how the system control knows the tracking and spindle servo loops are locked. Refer to the spindle servo block diagram for details.

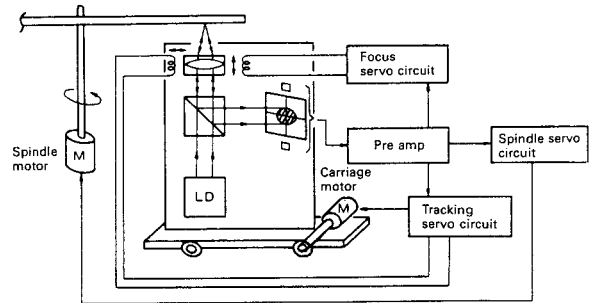
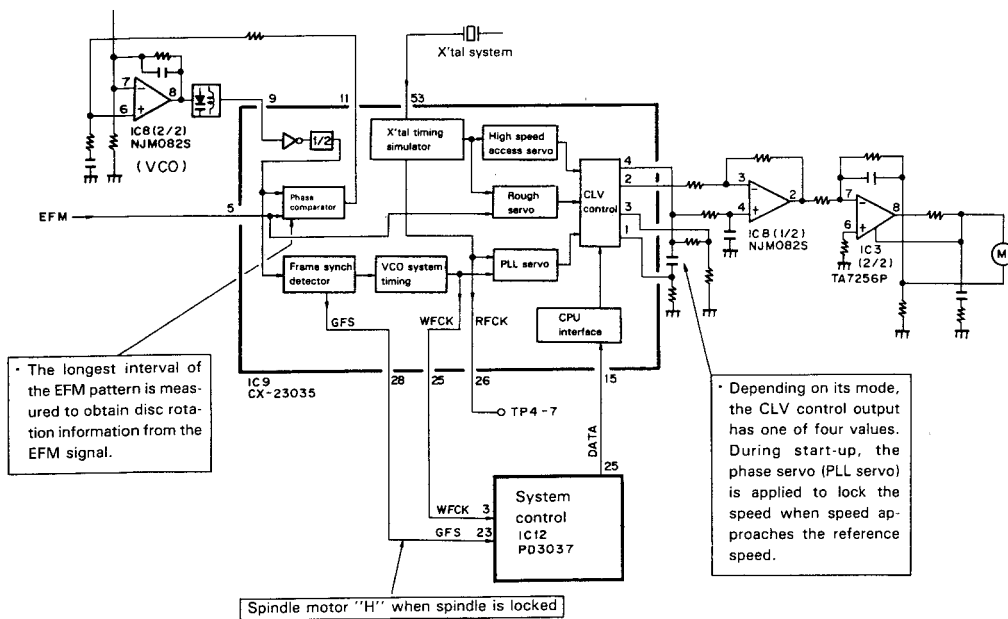

Fig. 3-7



Block diagram of spindle servo

Fig. 3-8

3.1.2 Tracking Servo Loop

PURPOSE:

To control horizontal alignment of the CD pickup so that the laser beam is accurately aimed at the pits on the disc surface. On/off switching of the tracking servo is used during track jump and search to locate the desired point on the disc.

Start-up Conditions

1. Proper focusing (FOK signal)
2. Spindle motor rotating.

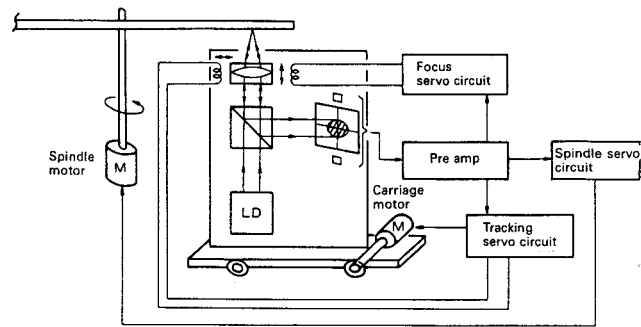
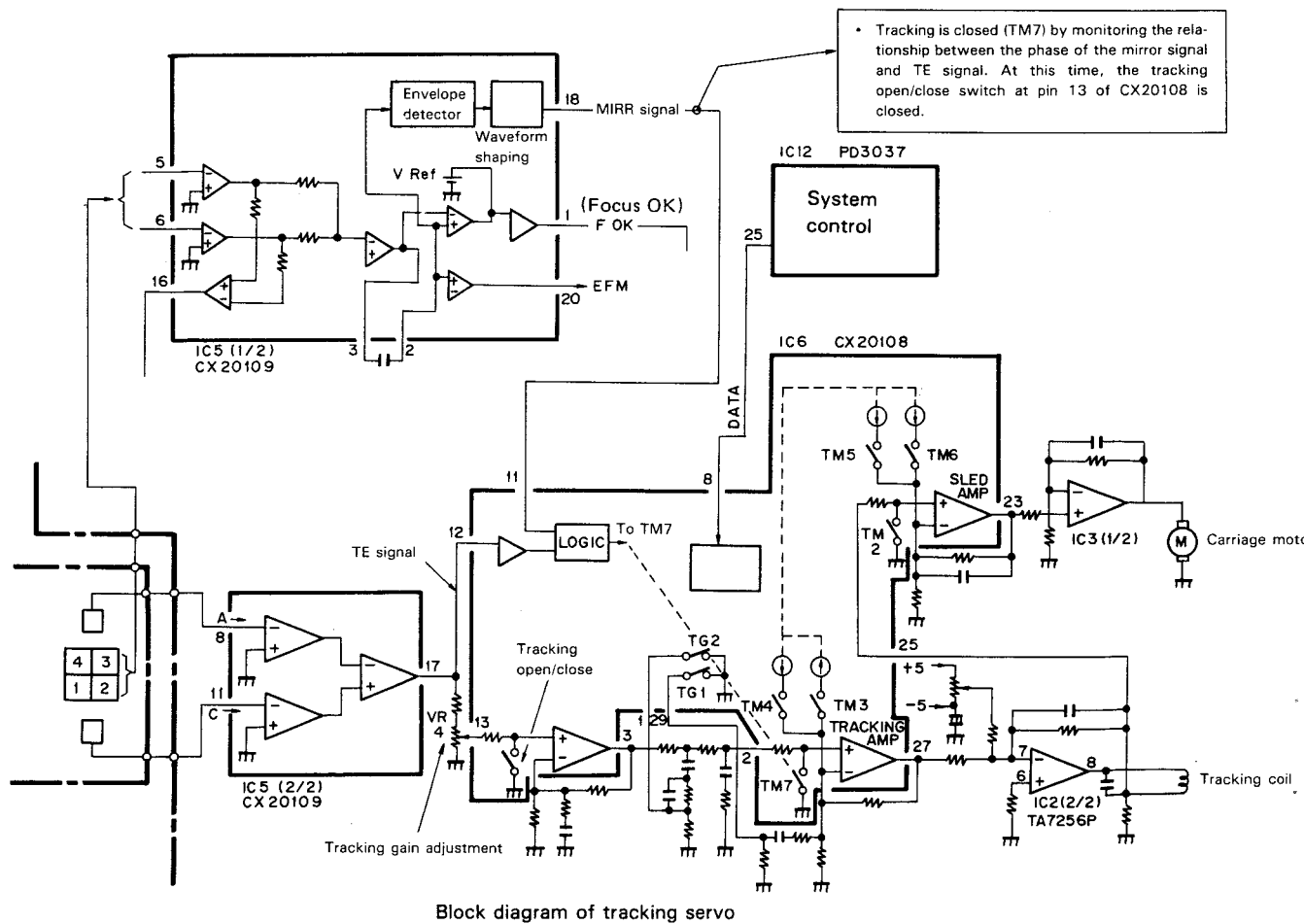

Fig.3-5 Tracking servo loop circuit



Block diagram of tracking servo

Fig. 3-6

Initial Settings for Reading of Table of Contents

Conditions:

- ★ Carriage is inside and the inside switch S102 is on.
- ★ Loading is completed and loading switch S101 is on.

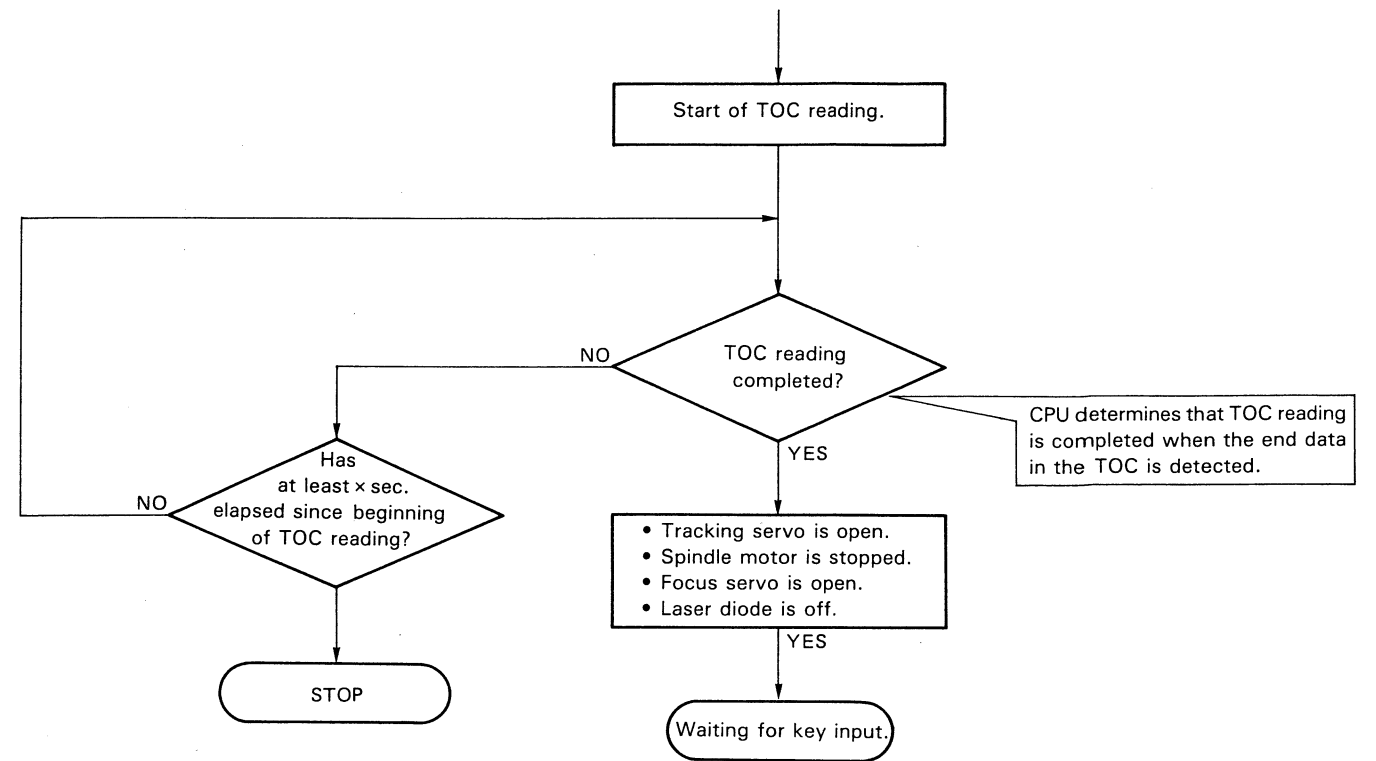
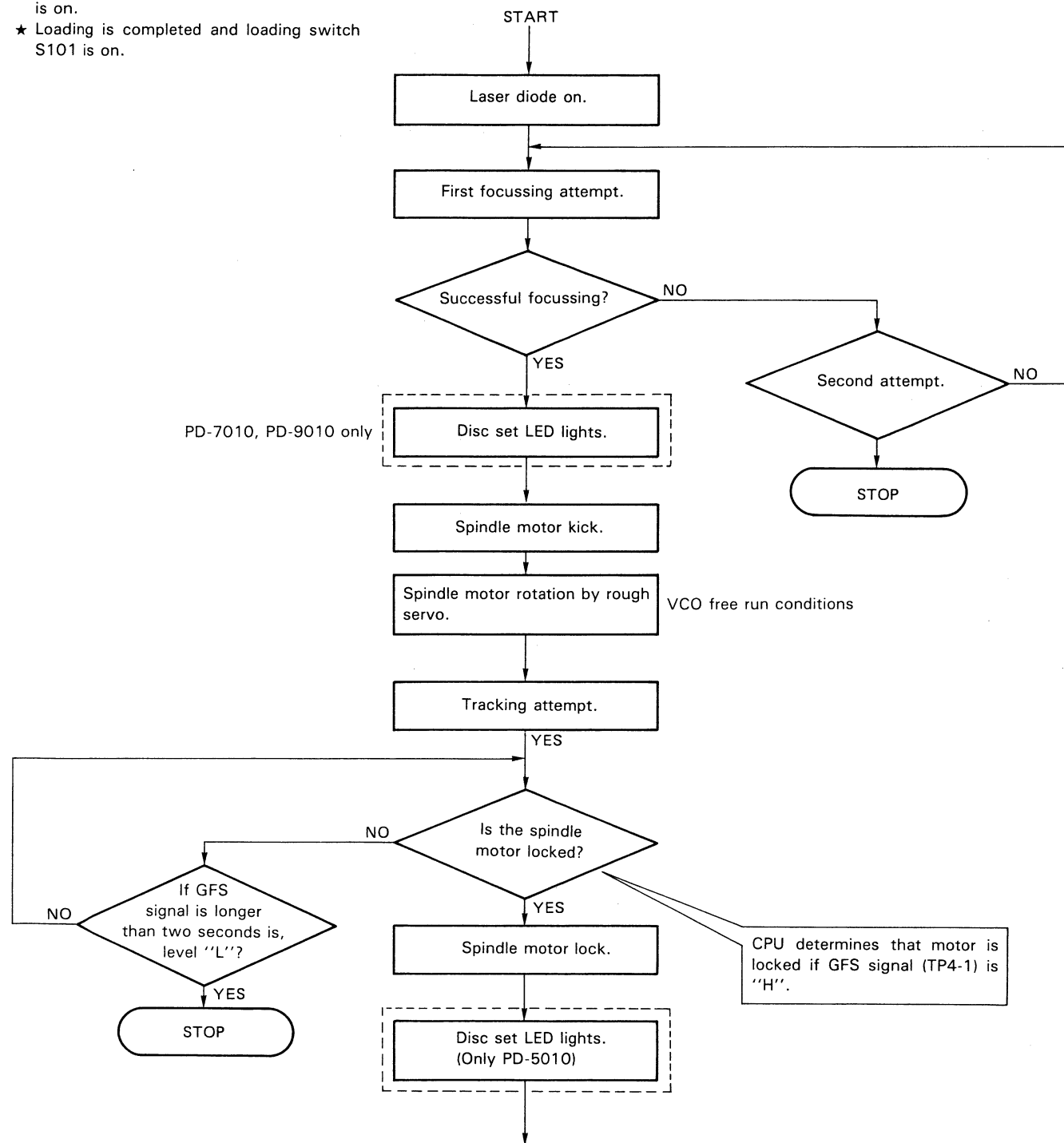

The operations described in this flow chart are carried out in TEST MODE.

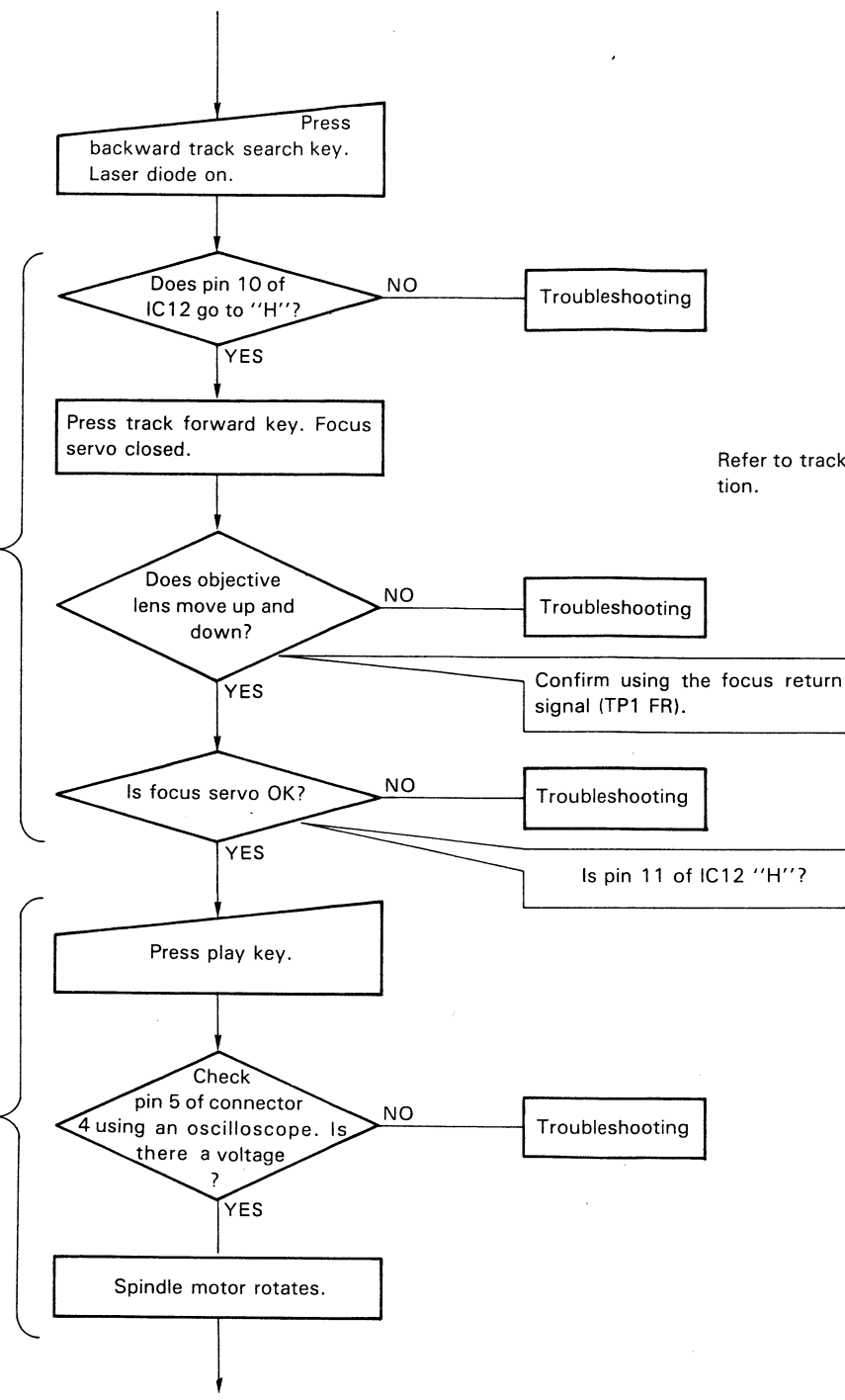
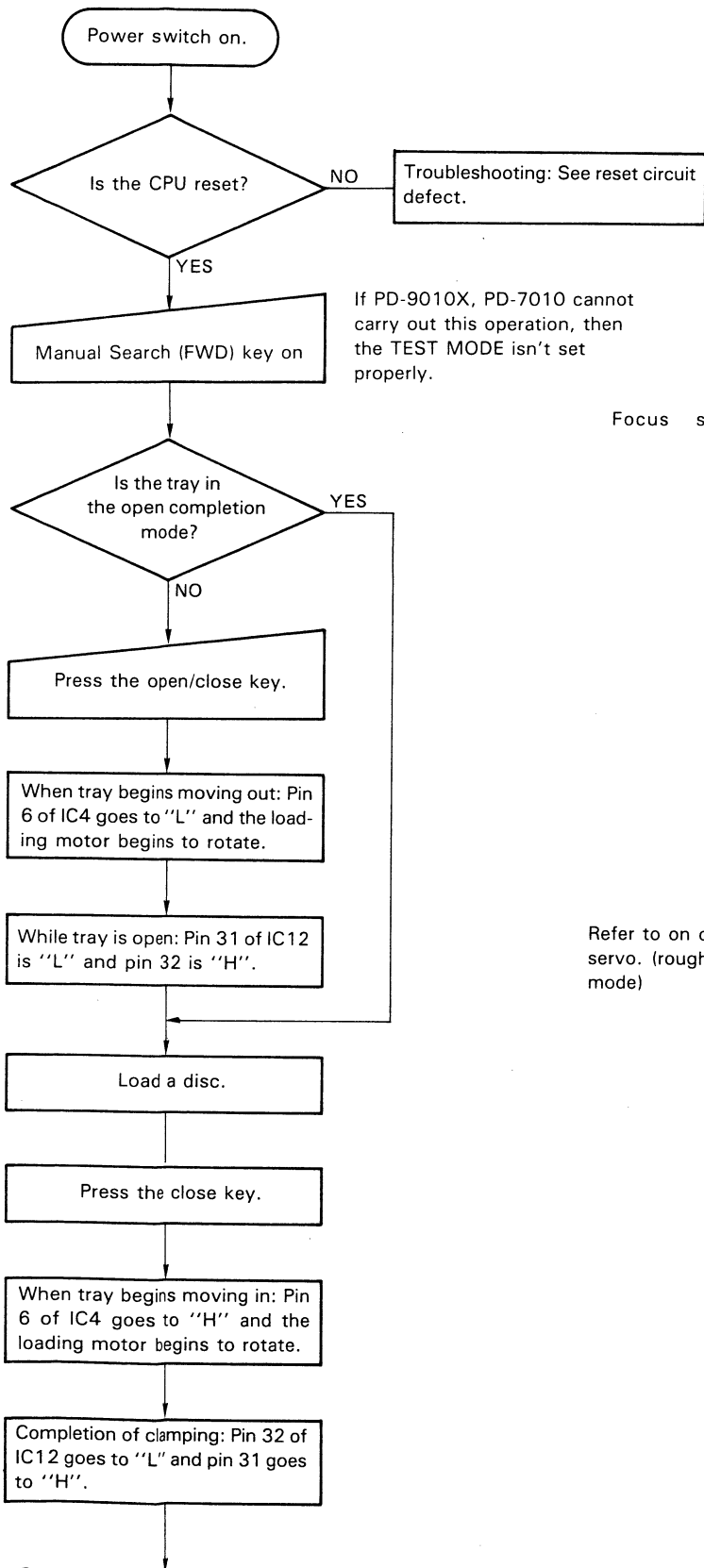

Focus servo operation.

Refer to on operation of spindle servo. (rough servo for the test mode)

Refer to tracking servo on operation.

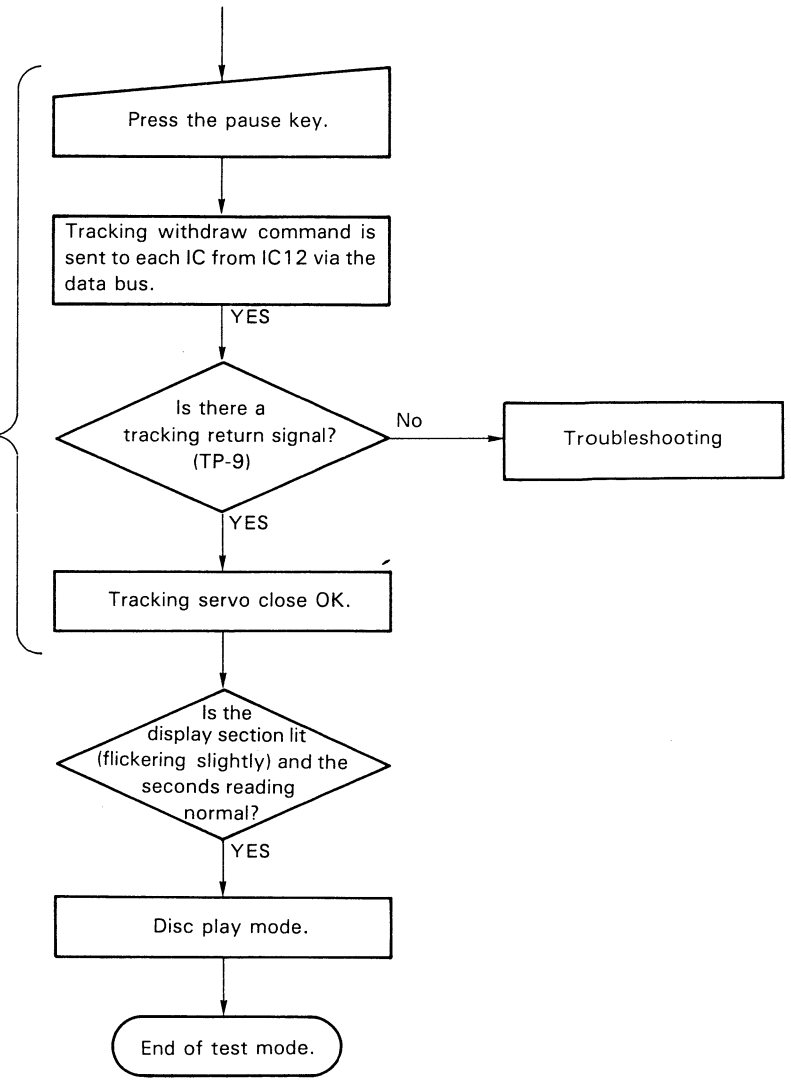

Timing Chart

● Timing Chart

(POWER ON→PLAY)

: Designed on the basis of PD-9010/7010.
(Refer to PD-9010/7010 for IC Pin Nos., etc.)

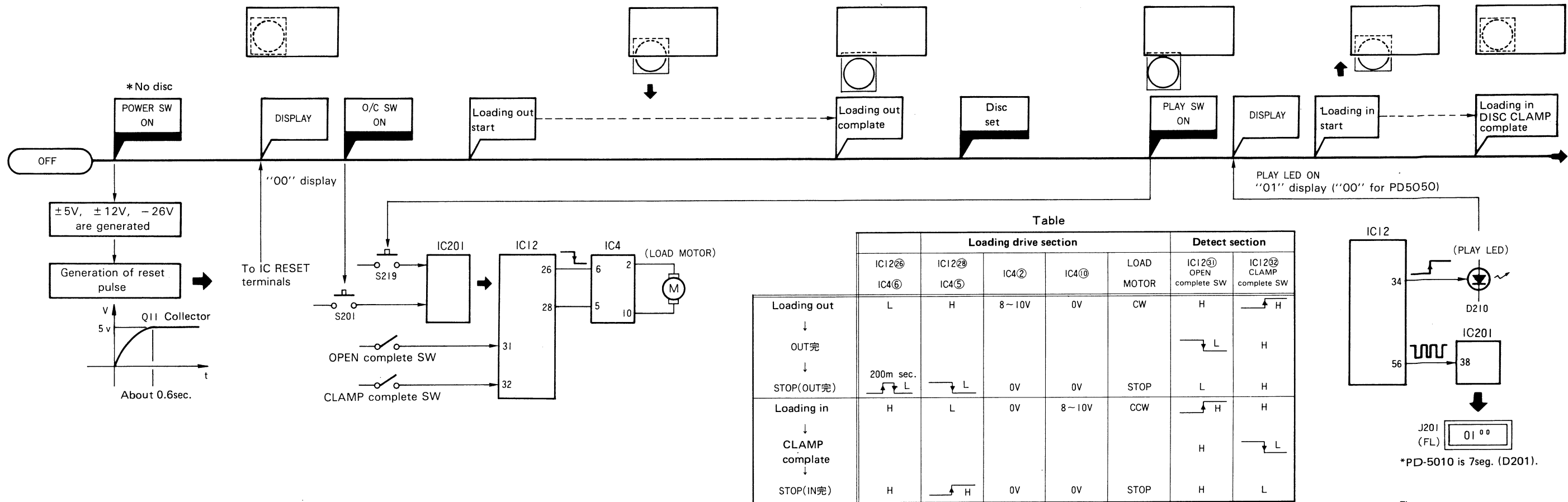

Fig

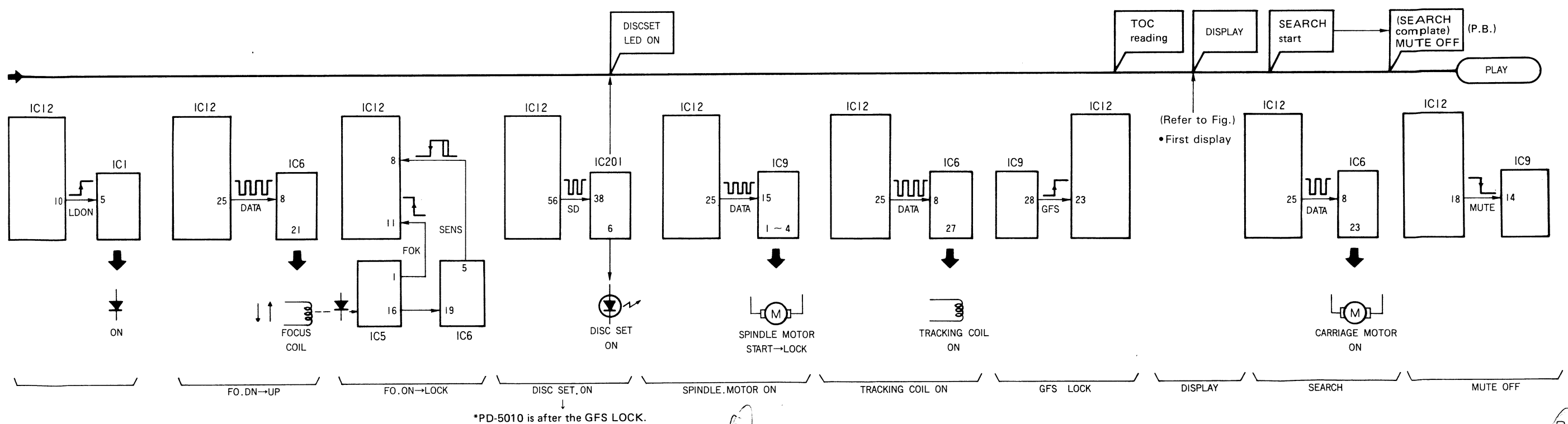

3.2 CIRCUIT DESCRIPTIONS

(1) Preamp

This section processes the output signal received from the pickup and then sends signals to the servo section of the next stage, the demodulator and the controller. CX20109 and other parts of the preamp are described below.

The IC is a 24-pin flat package; its internal configuration is shown in fig. 3-9.

A description of the internal parts of the IC follows.

1. RF amp

The pin diode currents input at PD1 and PD2 each undergo I-V conversion at the 60kohm equivalent input resistors of RF I-V amps (1) and (2). Then $(B1 + B2 + B3 + B4)$, added at the RF summing amp, is output to RFO.

(An eye pattern check can be performed at this terminal.)

The low frequency component of the RFO output voltage VRFO is:

$$VRFO = -[(R30 + R32)/10\text{kohms}] \times (VA + VB) \\ = [(R30 + R32)/10\text{kohms}] \times (iPD1 + iPD2) \times 60\text{kohms}$$

Furthermore, C1 and R3, have been provided because they are necessary for equalizing the EFM eye pattern.

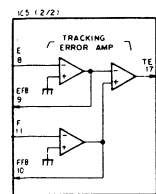
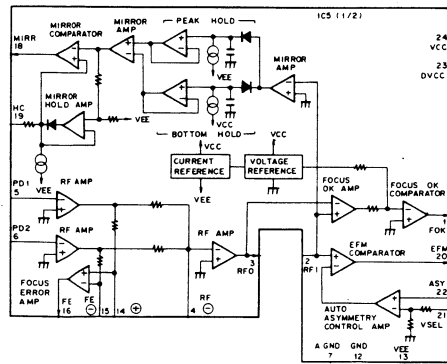

Fig. 3-9

This equalizer raises high range gain at an external circuit. The equalizer has a response peak in the high range to compensate for the drop in high range gain in the IC itself. The RFO output (pin 3) is an RF (DC) signal having a peak of 2.3V (DC) and a bottom of 0.5V (DC).

The high range pole setting is 2.5.MHz, however this is attenuated above around 1MHz because of the high range characteristics of the op amp inside the IC. As a result, the amplitude of high range signals such as 3T is raised.

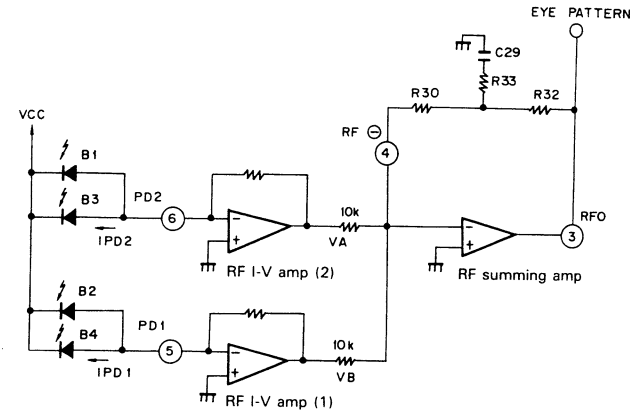

Fig. 3-10

2. Focus error amp

The difference between the output of the RF I-V amp (1) $(B2 + B4)$ and RF I-V amp (2) $(B1 + B3)$, $B1 + B3 - B2 - B4$, is computed and output.

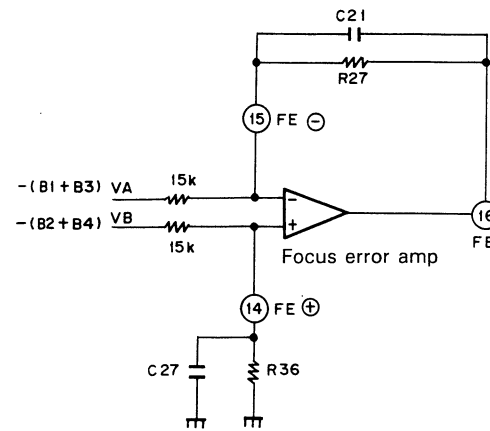

Fig. 3-11 Focus error amp circuit

When $R27 = R36$, the FE output voltage (low frequency) is:

$$VFE = R27/15\text{kohms} \times VA - VB = R27/15\text{kohms} \\ \times (iPD2 - iPD1) \times 60\text{k}$$

C21, C27 is needed to prevent leakage of the EFM component into the focus error output. Due to the gain setting, $R27 = R36 = 100$ and $C21 = C27 = 56$ (PF). That means $fc = 28.4\text{kHz}$. For the pin 16 output, a 5V p-p output in the form of an S curve is output.

3. Tracking error amp

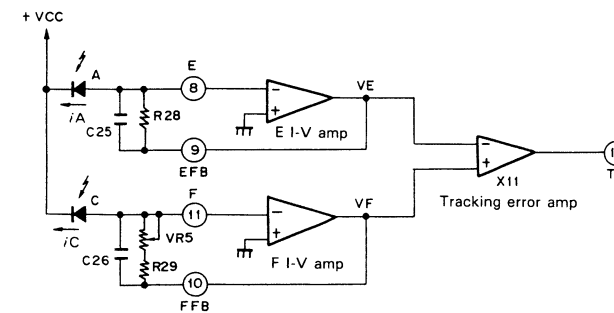

Fig. 3-12 Tracking error amp circuit

The current of the sidespot pin diode that is input at E and F undergoes I-V conversion at the E and F I-V amps $(R28$ and $R29 + VR5)$ in the following manner:

$$3VE = iA R28 \\ VF = iC (R29 + VR5)$$

Then, the difference between the two I-V amps is calculated at the tracking error amp to produce the output $(E - F)$. The gain of the tracking error amp for 11 (21dB) is:

$VTE = (VE - VF) \times 11 = (iA - iC) \times R28 \times 11$
C25, C26 is required to prevent leakage of the EFM component into the tracking error output.

The gain setting makes $R28 = R29 + VR5 = 150\text{kohms}$ and $C25 = C26 = 47\text{PF}$. Here, $fc = 22.6\text{kHz}$.

$R29 + VR5$ includes adjustment VR. This is tracking error balance for the purpose of obtaining a DC balanced tracking error signal such as the one shown in figure 3-17. It is needed primarily to perform tracking jump properly. The output of pin 17 is a 4V p-p tracking error signal.

4. Focus OK circuit

The focus OK circuit makes the timing window for switching on the focus servo from the focus search mode.

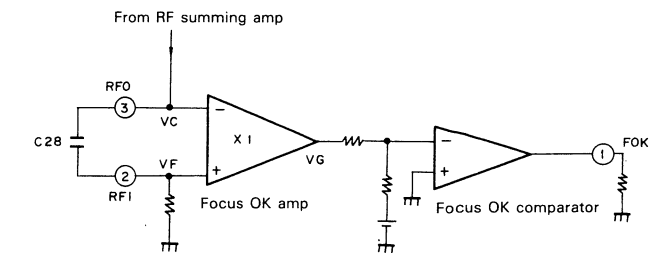

Fig.3-13 Focus OK circuit

The threshold value VTH of the focus OK comparator is set so that it is reversed when $VG = -0.4\text{V}$. Therefore the focus OK comparator is reversed when $VRFO = VC = 0.4\text{V}$. The threshold value of this comparator is stable due to the accuracy of the reference voltage within the IC.

C28 determines the time constants for the EFM comparator, mirror circuit high-pass filter and focus OK amp low-pass filter. This makes it possible to prevent the worsening of the black error rate caused by the RF envelope loss when scratches and other disc damage is encountered.

In this system, $0.0047\mu\text{F}$ is used as the optimum value for C28. For this value, $fc = 3.4\text{kHz}$ and the RF offset current is unnecessary.

5. Mirror circuit

After amplifying the RFI signal, peak and bottom hold are performed. For peak hold, the time constant is such that the 30kHz traverse can also be followed. For bottom hold, the time constant is such that the rotation cycle envelope fluctuations can be followed.

The DC restored envelope signal is obtained by performing differential amplification of these peak/bottom hold signals. By comparing this signal with the signal held

by peak hold at 2/3 of the peak level using the large time constant, the mirror output is obtained. In other words, mirror output is "L" when over a track (row of pits) and "H" when between tracks (rows of pits). Furthermore, "H" is also output when a defect is detected. The time constant for mirror hold must be sufficiently larger than the traverse signal.

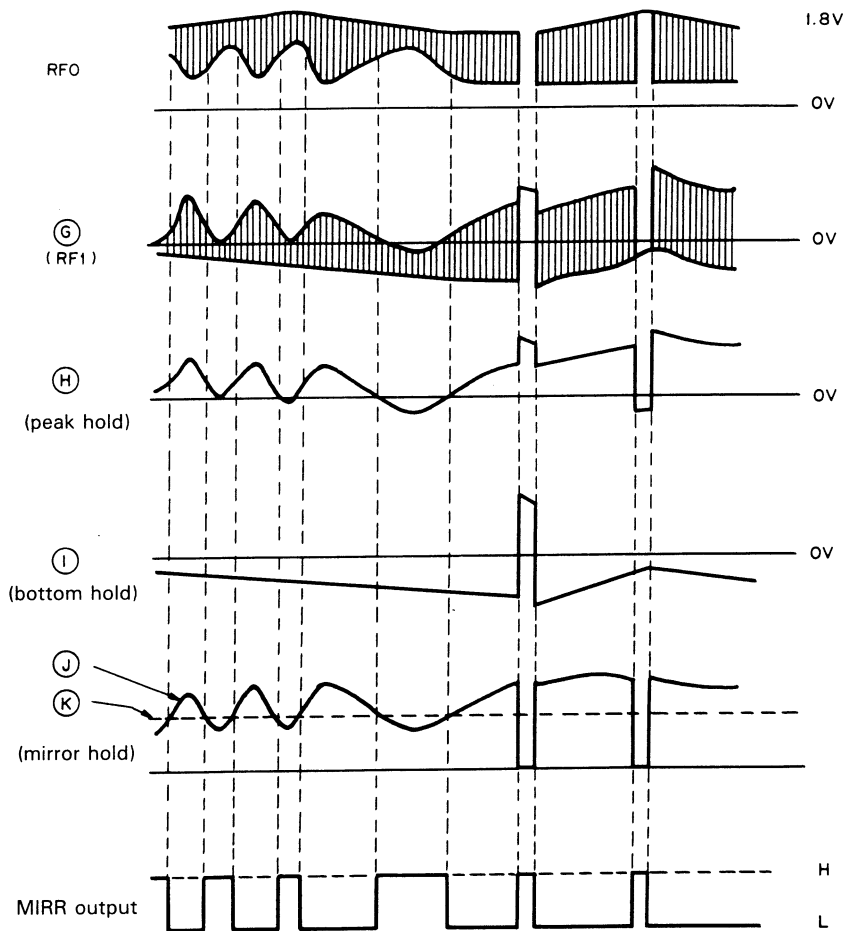
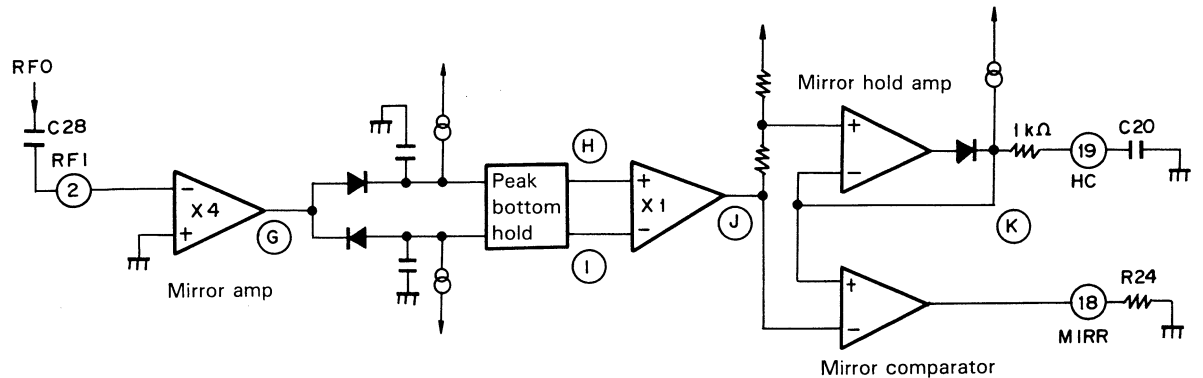

Fig.3-14 Mirror circuit

6. EFM comparator

The EFM comparator serves to convert the RF signal into a signal having two values. Problems caused by disc asymmetry can not be dealt with by AC linkage alone. Therefore, the EFM comparator reference voltage is controlled by using the fact that a 1.0 occurrence probability becomes 50% for each of the two EFM signals.

Because this EFM comparator is a current switch type unit, the H and L levels do not become the same as that of the power supply voltage. It is, therefore, necessary to

apply feedback through a CMOS buffer. R25, R90, C22 and C60 are the low-pass filter needed to obtain DC +2.5V. If f_c is 500Hz or more, leakage of the reduced component of EFM becomes serious, resulting in a worsening of the block error rate. This system has two stages, one in which $R_{25} = 100\text{kohms}$ and $C_{22} = 0.47\mu\text{F}$ so that $f_c = 3.4\text{Hz}$ and a second in which $R_{90} = 10\text{kohms}$ and $C_{60} = 0.01\mu\text{F}$ so that $f_c = 1.6\text{kHz}$.

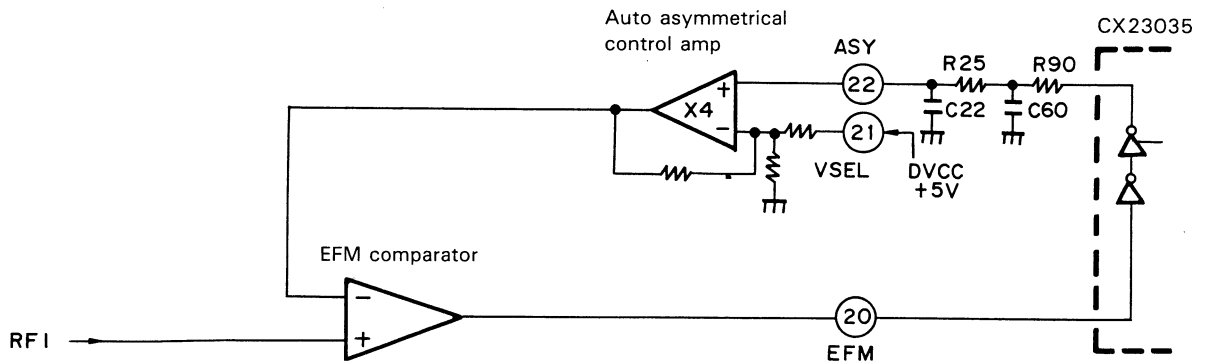

Fig. 3-15 EFM comparator circuit

Servo Section

This section uses an external control signal for focus servo, tracking servo and carriage servo operation (normal servo operation) and special servo control operation such as focusing and track jump. Its primary component is a IC CX20108 chip. To improve servo performance with regard to disc scratches and other disc defects, a discrete defect correction circuit is included.

The IC is a 30-pin flat package having a construction as shown in figure 3-16. A description of each section follows. The operation modes and data of this IC are shown in Table 3-1.

COMMAND	ADDRESS				DATA				SENSE
	D7	D6	D5	D4	D3	D2	D1	D0	
FOCUS CONTROL	0	0	0	0	FS4 FOCUS ON	FS3 GAIN DOWN	FS2 SEARCH ON	FS1 SEARCH UP	FZC
TRACKING CONTROL	0	0	0	1	ANTI SHOCK	BREAK ON	TG2 GAIN	TG1 SET *	AS
TRACKING MODE	0	0	1	0	TRACKING MODE *		SLED MODE *		TZC

TRACKING MODE		SLED MODE	
	D3	D2	D1 D0
OFF	0	0	OFF 0 0
ON	0	1	ON 0 1
FWD JUMP	1	0	FWD MOVE 1 0
REV JUMP	1	1	REV MOVE 1 1

Table 3-1

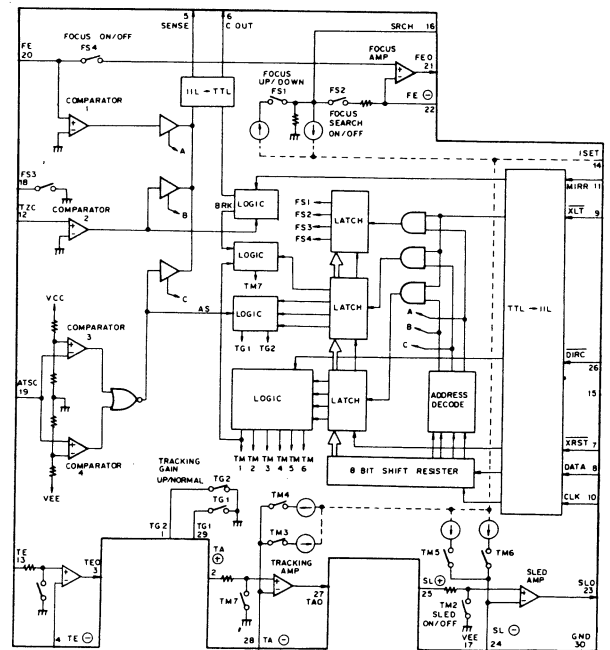

Fig. 3-16

1. Command codes

The modes of both IC CX20108 and the demodulator IC CX23035, which will be discussed later, are controlled by the serial data (from the control microcomputer). All types of detection outputs are output from the "SENS" terminal. These control data and detection outputs link the control microcomputer, CX20108 and CX32035 in the form of a control bus line. The DATA, C, LK (serial) for mode control and XLT timing for starting execution are shown in figure 3-17.

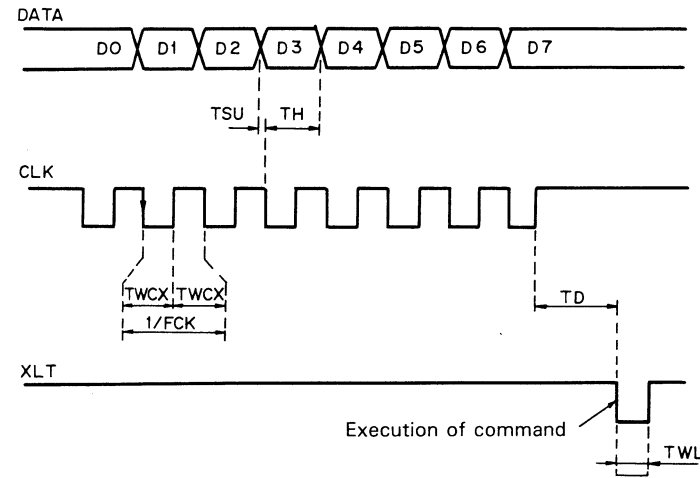

Fig. 3-17

Item	Code	Standard			Unit
		Min.	Std.	Max.	
Clock frequency	FCK			250	kHz
Clock pulse width	TWCK	2			μS
Set-up time	TSU	-0.1			μS
Hold time	TH	4			μS
Delay time	TD	4			μS
Latch pulse width	TWL	1			μS

Table 3-2

2. Focus-in sequence

(a) Focus servo

The focusing sequence moves the lens to within the focus S-curve and closes the servo loop at the center of the S. For moving the lens up and down, the following section of the IC is used.

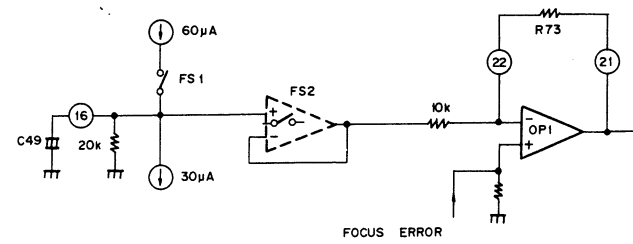

Fig. 3-18

Operation of FS1 and FS2 is as follows. The numbers shown in fig. 3-18 (and in this section) are pin numbers of CX20108. op1 is the op amp used for the focus servo. The FS2 output is sustained at the reverse terminal. For 1, FS2 is on and operates as a normal voltage follower. For 0, FS2 becomes a switch to give this output a high impedance. FS1 is simply a current switch that is off for 1 and produces a current of 60μA for 0. The 60μA figure is the value when 240μA is sent to ISET (pin 14). The focus search voltage can, therefore, be produced by using FS1 and FS2.

In this system, 89μA is fed to ISET. That means the positive current supply is 22μA and the negative current supply is 11μA. Here, the voltage of pin 16 is:

$$\text{When FS1 is off: } -11\mu\text{A} \times 20\text{kohms} = -0.22\text{V}$$

$$\text{When FS1 is on: } (22 - 11)\mu\text{A} \times 20\text{kohms} = +0.22\text{V}$$

This is returned to original form and used to perform up/down lens movement. Furthermore, all current supplies for the tracking servo drive described below are 22μA.

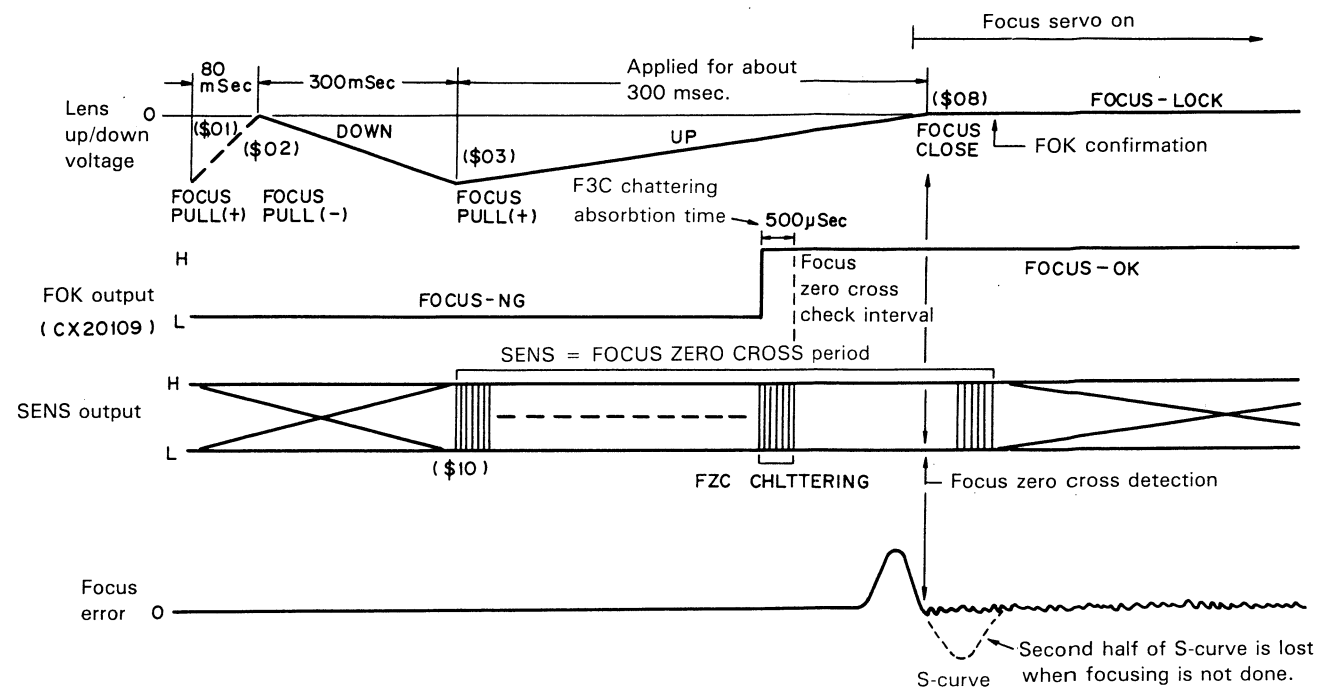

Fig. 3-19

In the sequence shown in fig. 3-19, focusing is being performed. First, for lens up/down movement, FS1 of fig. 3-18 causes the control microcomputer to reset CX20108 when power on is reset. As a result, the internal register becomes \$00, the focus mode. At this time, FS1 is on so the voltage at pin 16 is +0.22V.

Although the focusing sequence is as shown in fig. 3-19, positive charging of pin 16 when power is switched on corresponds to lens drive in the downward direction. Consequently, switching FS2 on immediately would cause the lens to move downward rapidly. To prevent this from occurring, FS1 is switched off and negative charging is performed. FS2 is then switched on to begin the drive sequence only after pin 16 has reached ground potential (approximately).

The usual sequence is as follows. The lens is lowered (max. of 1mm) and then raised. When the lens approaches the S-curve, "FOK" (the focus output based on the RF output) goes to "H", the center of the S-curve is detected using the SENS output and the servo loop is closed.

The maximum amount of lens movement in the upward direction is also 1mm (see fig. 3-19). If focusing can not be done the first time, the lens is lowered and raised again in a second attempt to attain proper focusing. Focusing is attempted no more than two times. If proper focusing is still not possible, the unit proceeds to a processing routine.

For focus error zero cross detection in this system, a window comparator in CX20108 is used. The input for this comparator is pin 19 "ATSC". As is shown in the table, comparator output is obtained from "SENS" when in the tracking control mode. By doing this, instability occurring immediately before and after a focus error and mistaken zero cross point detection due to focus error offset are eliminated. Here, the threshold is about ±0.65V.

(b) Main loop

This loop consists of a one stage low range gain compensator, one stage high range phase compensator and two stage high-cut filter for high range noise attenuation. The main loop is designed to provide a residual error of under $-1 \mu m$ as well as excellent playability, taking into consideration the above characteristics and disc standards (including pickup actuator performance).

3. Tracking servo

(a) Brake mode circuit

The brake mode circuit is constructed to make possible the smooth closing of tracking when the pickup and disc are moving in relation to each other. The directions of pickup and disc movement are detected using the phase relationship between the envelope and tracking error (at RF). Switching is conducted in such a way that the accelerating side of the tracking error is cut. Consequently, only the decelerating side is used. This operation, called the brake mode, is shown in fig. 3-20 and 3-21. External control of the activity and inactivity of this mode is possible.

The brake mode is used when closing tracking after focusing. By doing this, smooth focus closing is possible even for tracks (lines of pits) whose distance to the pickup is varying greatly due to disc eccentricity, warping and other factors.

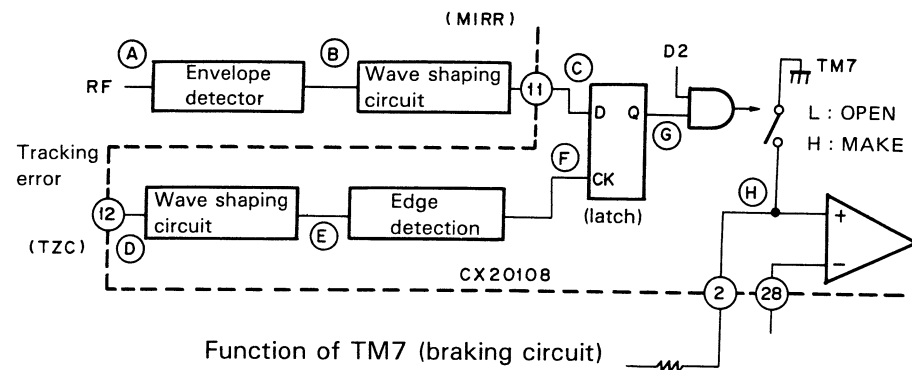

Fig. 3-20

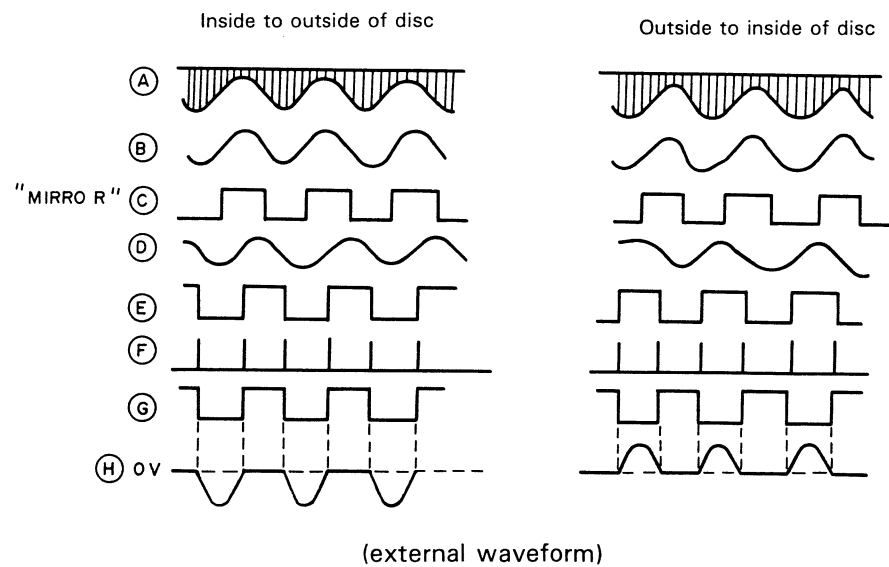

Fig. 3-21

(b) Main loop

There are two gain settings for normal disc play, the normal gain setting and the higher gain setting for track jump. The main loop consists of a one stage fixed low range gain compensator, one stage switching reduced gain compensator, one stage switching high range phase compensator and two stage high range noise cut filter.

As shown in the diagram, there are two low range and two high range stages at the normal gain setting and two low range and one high range stage at the high gain setting. Fig. 3-22 shows the circuit configuration of this section. For normal gain, both TG1 and TG2 are on; for the high gain, both TG1 and TG2 are off.

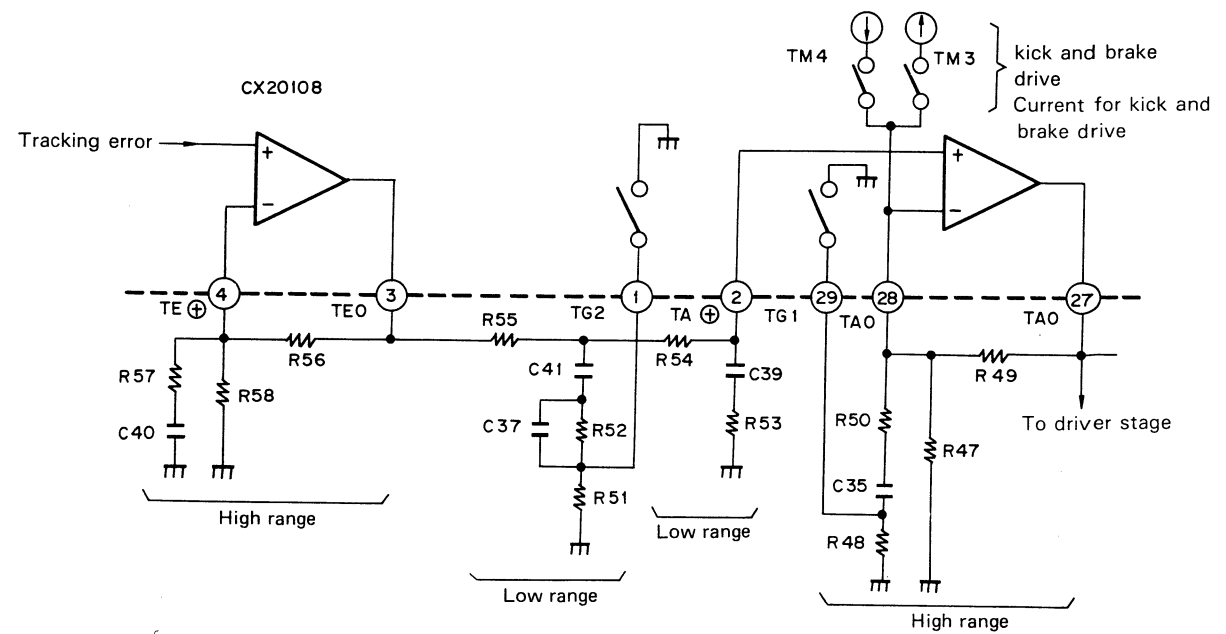

Fig.3-22

The drive current supply is, as was shown earlier, $22 \mu A$. Therefore, in this system the output voltage of pin 27 is the voltage obtained when this current is applied to the resistance between pins 28 and 27 (9.1kohms). In this case, the output voltage is 200mV. This becomes the kick and brake drive voltage (the output voltage of pin 27). This output voltage is then used for current drive of the tracking actuator in the final driver.

4. Carriage servo

The return resistance voltage of the tracking actuator current driver final stage is used as the input (see fig. 3-23). The required carriage movement components are obtained by using the filter characteristics.

The carriage movement drive is performed by controlling the current supply in CX20108 with the serial data so that the output is a DC voltage. Because this type of

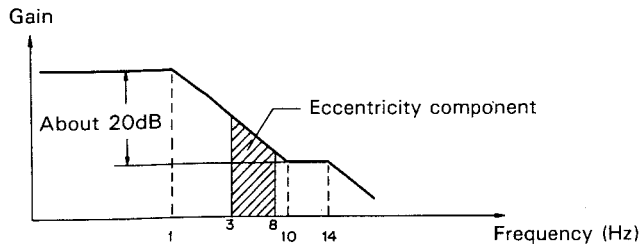

Fig. 3-23

carriage drive system is used, the final stage employs voltage drive. The power supply is unregulated, so the drive voltage is also unregulated when carriage movement is started. Due to the gain setting, the movement drive is limited at about $\pm 11V$. Consequently, motor drive becomes a DC voltage when the unregulated voltage becomes high.

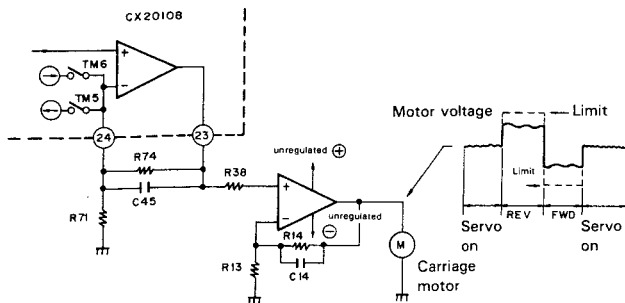

Fig. 3-24

5. Defect processing circuit

This circuit detects disc defects (scratches, dirt, etc.) and switches the focus servo loop equalizer to improve playability when defects are encountered. (A) is the output of the leading beam of the 3-beam tracking pickup. It is obtained from the preamp. This output changes in the manner shown on the right when a defect is encountered.

The output is amplified at IC7 2/2 and ends up as shown in diagram (B) due to a capacitor that extends the droppoff in the output. By routing this output through a comparator, output (C) becomes correct from the beginning of the defect period to the point where the 2.4msec. time constant component is extended (after the defect period has ended). The focus servo equalizer is switched by using this procedure. Equalizer switching is executed by switching the Transistors of Q2 and Q3 on using (C) output.

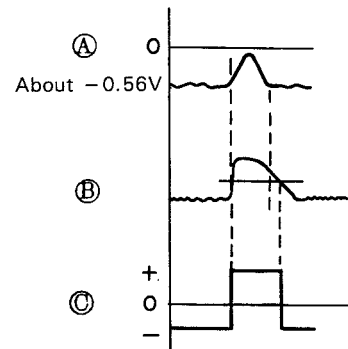

Fig. 3-25

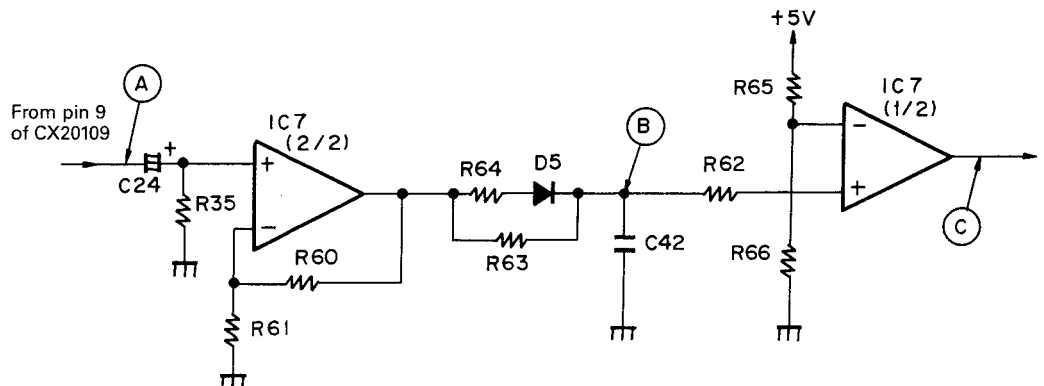

Fig. 3-26

(3) Demodulator

The demodulator is composed primarily of LSI CX23035; it also includes a small amount of added-on circuits. Its functions are:

1. Bit clock regeneration using the EFM-PLL circuit.
2. Demodulation of the EFM data.
3. Detection, protection and internal extension of the frame synch signal.
4. Powerful error detection and correction.
5. Interpolation using averaging or previous value hold.
6. Demodulation of the sub-code and error detection for sub-code Q.
7. CLV servo for the spindle motor.
8. 8-bit tracking counter.
9. CPU interface using the serial bus.

Of these nine functions, an external circuit is required for the PLL section and CLV servo. All other functions are performed by the LSI alone. Here, the external discrete circuitry will be discussed.

The external circuitry consists of a loop filter and its amplifier and VCO.

Pin 11 "PDO" of CX23035 emits an output when an error is encountered. The loop filter is a low-pass filter for this output having a 70Hz pole and 1.6kHz zero point. The output is amplified by the error amp and sent to VCO. The main amplifier of VCO is within CX23035.

An output signal is produced from MDP and MDS according to the CLV servo mode of CX23035. The mixed filter section is a low-pass filter having a cut-off at about 500Hz and the loop filter is a low-pass filter having a cutoff at about 300kHz. FSW switches the mixed filter cutoff to about 20Hz with regard to the CLV servo motor. MON causes the loop filter output to become 0V; it is operated by the stop motor.

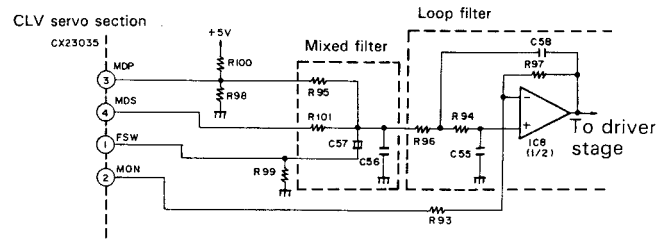

Fig. 3-28

2. AUDIO SECTION

In the high end models of this CD player series, a digital filter is employed. This digital filter is IC CX23034. It doubles the sampling frequency to 88.2kHz; it is a 16-bit 96 tap FIR filter. By using this filter:

1. Group delay near the cut-off frequency is greatly reduced.
2. The cut-off characteristics are almost perfect. In addition, high end distortion is lower and signal transmission performance is improved.

Other audio circuits are basically the same as those of conventional components, however, except for the top of the line model, deemphasis switching and muting are performed by transistors. Also, deemphasis is switched on during manual search to reduce high range noise. Muting is provided to suppress noise produced when power is switched on. It is controlled by a timing signal from a discrete circuit.

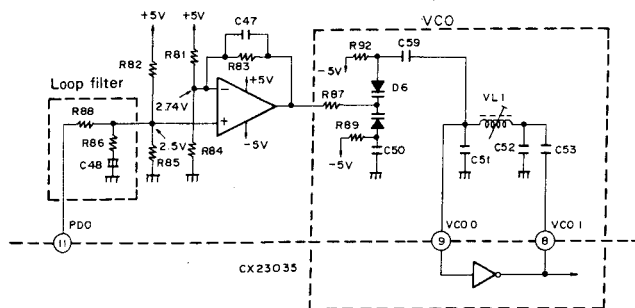

Fig. 3-27

3. OPTICAL SECTION

(1) Optical path and elements

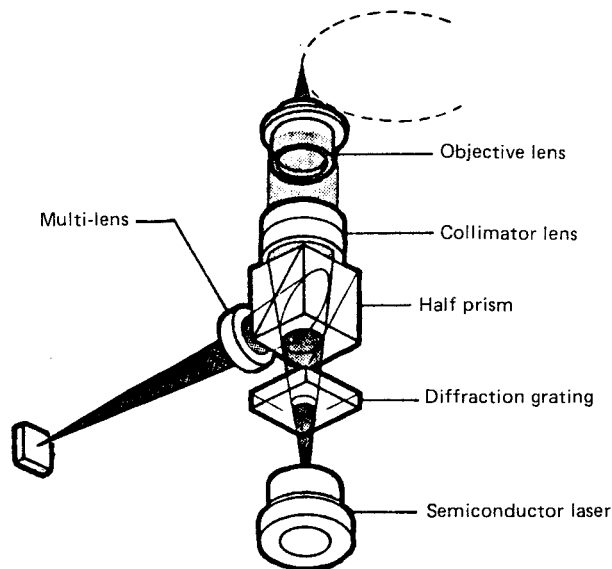

Fig.3-29 Optical path and elements

The path of the laser beam and arrangement of the optical elements are shown in fig. 3-29. The semi-conductor laser emits a beam of light having a wavelength of $780 \mu\text{m}$. It is barely within the range of visibility. The beam is produced from an extremely small point and has an elliptical distribution. It is dispersed in a conical shape.

To produce the beam used to detect tracking error, the beam is passed through a diffraction grating that splits the beam into three beams, the primary beam (zero order) and two side beams (± 1 order). A small amount of higher order elements are also produced, but these are lost without being used. Next, the beams are passed through a half prism where 50% of the energy is lost. Details of the half prism are described later in this publication.

The collimator lens produces a completely collimated beam. The diameter of the collimated beam is large enough to cover the movement of the objective lens. The beam is then condensed a spot having an extremely small diameter by the objective lens before going on to the disc. Part of the beam is then reflected back from the disc, diffracted and routed back through the objective lens where the returning beam is collimated and then the collimator lens where the beam is condensed.

When this beam reaches the half prism, 50% passes through the grating and returns to the laser diode. The other 50% is reflected by the prism to the multiple lens that has the functions of both a concave and cylindrical lens. This beam then goes to the photo diode alley where an electrical signal having a strength proportional to the intensity of the beam is produced. This completes the discussion of the optical path. Next, its features compared with those of a video disc player will be discussed.

The first feature is that the outgoing path is a straight line. That means no auxiliary parts to alter the light path are needed, so overall tolerances can be minimized. As a result, adjustments of optical part installation locations are also minimized. The development of the double shaft actuator for use in the parallel drive method allowed the objective lens unit to be reduced in size. This makes it possible to maintain very satisfactory performance while using compact optical parts.

The second feature is the half prism. In the video disc player optical system, the outgoing and incoming light paths are separated by a $1/4$ wavelength plate and polarizing beam splitter. The reasons why the half prism can be used in a CD player but not a video disc player are primarily:

(1) Although a semi-conductor laser diode is much smaller than an He-Ne laser, it nevertheless has a fairly high optical output power. Therefore, the energy loss caused by the half mirror is not a problem.

(2) (A) shows an He-Ne laser beam reflected from
(3) Both video and compact discs tend to polarize light because they are made of a resin based material that is not perfectly flat. In video discs, the amount of polarization is carefully checked against an established standard. In compact discs, the limitation is not very strict. Because of the lack of a strict standard, CD players normally use an extremely accurate $1/4$ th wavelength plate. In actual use, however, this plate can not function properly due to polarization of the laser beam caused by the disc. A half prism, on the other hand, is not at all affected by polarization of the laser beam. Consequently, a very stable optical path can be made.

Another feature of this optical system is the use of a parallel drive unit to allow optimum utilization of the objective lens at all times. As is shown in fig. 3-30, the beam from the laser diode is converted into a completely collimated beam by the collimator lens. The parallel drive unit causes the objective lens to move parallel and perpendicular to the beam. Therefore, the optical path is not often affected by movement of the objective lens within the collimated light cluster.

Another feature of the optical section is the use of a multiple lens. This lens prevents the focusing point depth on the photo diode from becoming too shallow, a problem that has appeared as optical sections have become more compact. It is an effective way to permit lowering of the installation accuracy required by the photo diode. This multiple lens is a cylindrical lens having the functions of a concave lens. Previously, there were two beams and both a concave and cylindrical lens. In this pickup, however, one lens performs both functions, thereby allowing a further reduction in size.

When designing the optical section of a CD player, the most important point is the degree by which differences between various compact discs can be dealt with. To do this, it is desirable to have a very short wavelength. The wavelength actually being used is $780 \mu\text{m}$ because this is the shortest wavelength possible today with mass produced pickups.

The NA of the objective lens should also be made as small as possible to deal with disc variations. However, reducing NA adversely affects the performance of the optical system as a whole. Aberrations caused by differences between discs are generated geometrically in a form proportional to $1/NA^2$, $1/NA^3$, $1/NA^4$... Furthermore, the E.F.M. signal level decreases almost in proportion to NA under these conditions. Taking these factors into consideration and after many test calculations and experiments, it was determined that NA should be 0.45.

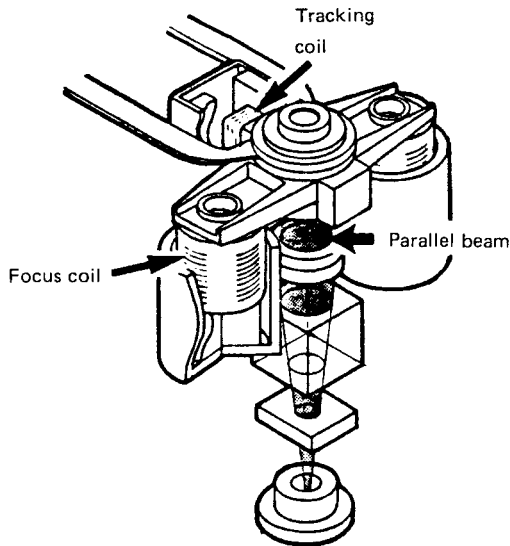

Fig. 3-30

(2) RF and servo signals

The beam, which has been reduced to an extremely small spot by the objective lens, now strikes the disc side on which the signal is located. Part of the beam is then reflected back to the objective lens and photo diode. A diagram showing how this beam is reflected off the disc is shown in figure 3-35. (A) shows what happens when the concentrated beam is directed at a pit. Normally, this reflected light would disrupt the output light beam. In the laser diodes used in CD players, however, noise is reduced instead, resulting in stable performance. This property is very advantageous for the half prism which allows only half of the light energy to pass.

A pit and (B) shows the same beam when reflected from a space between pits. In case (A), the beam is diffracted, so the dark part of the beam does not return to the objective lens. Instead, only the center of the beam passes through the objective lens and reaches the photo diode. In case (B), there is no diffraction because the beam does not strike a pit. Therefore, the entire beam is reflected back to the photo diode, producing brighter beam than when a pit is reached. In this system, the data on the disc, which is represented by pits, is covered into an electrical signal at the photo diode according to the intensity (brightness) of the reflected beam. The RF signal is then produced from this electrical signal by the computation circuit.

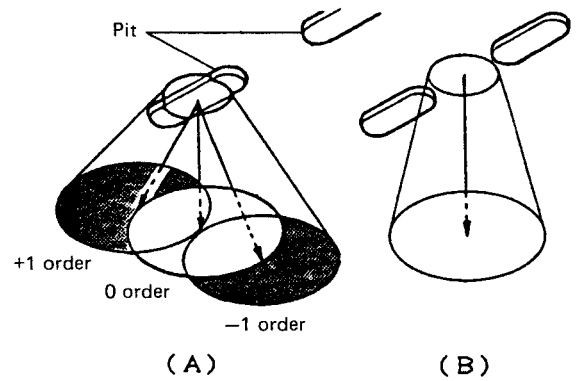

Fig. 3-31

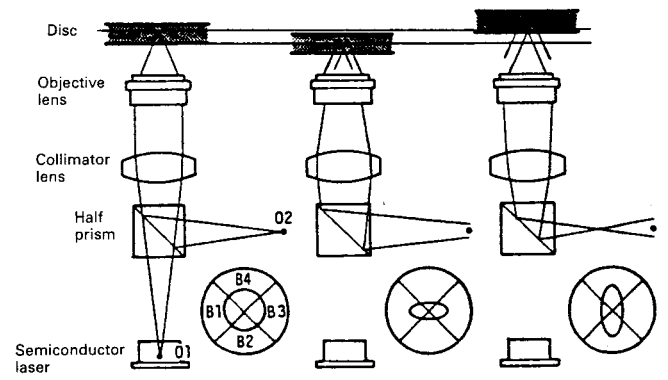

Fig. 3-32

Fig. 3-36 shows how the focus signal is detected. (1) is when the beam from the laser diode is accurately focused on the disc by the objective lens. (2) shows what happens when the disc comes closer to the pickup and (3) shows what happens when the disc moves farther away. The grating and concave lens, which have no direct effect on the focusing are not shown in the diagram.

In case (1), the beam emanating from point O1 is reflected and diffracted on the disc surface to produce the condensed beam (O2). In case (2), the beam is directed at a point farther than that of beam O2. Fig. 3-37 shows the properties of the cylindrical lens. Since the cylindrical lens is shaped as shown in the diagram, the lens is operated in the vertical direction of the diagram, not the horizontal direction. 1 through 7 shows the shape of the beam at each point. between points 2 and 6, which are in a straight line, the beam is circular at point 4. Point 6 corresponds to beam O2 of fig. 3-36. If we assume that fig. 3-37 shows mode (1) of fig. 3-36, that means the beam is circular because the photo diode is located at point 4. In mode (2) of fig. 3-36, the location of the photo diode is closer to the cylindrical lens than it was in fig. 3-37. That means the shape of the beam is the same as that of point 3 (an ellipse that has a longer width than height). In mode (3) of fig. 3-36, the shape of the beam is that of point 5, an ellipse that has a longer height than width.

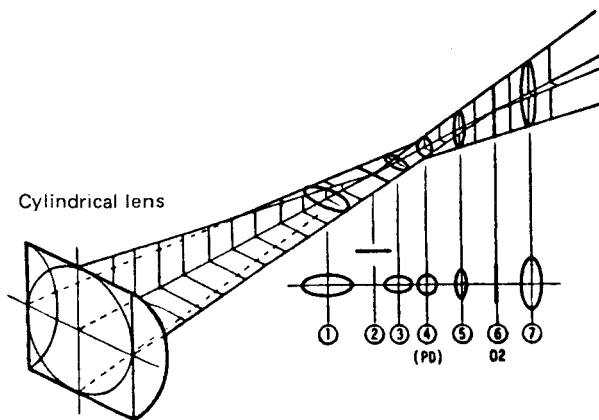

Fig.3-33 Cylindrical lens

These beam shapes are shown in fig. 3-36. By performing a $(B1 + B3) - (B2 + B4)$ computation using the B1-B4 photo diode quartering elements, the focus signal is produced.

Let's consider what happens as the objective lens is gradually moved closer to the disc. If the objective is fairly far from the disc, only a small amount of light will be returned to the photo diode. Furthermore, since the returning light is quartered, the focus signal would be 0.

If the objective lens is moved closer to the disc until point 7 of fig. 3-37 is reached, the shape of the beam at the photo diode becomes an ellipse that is higher than it is wide. The focus signal would then be positive because $(B1 + B3)$ is greater than $(B2 + B4)$. However, after the peak (vertical line) is reached at point 6, it begins to return to zero. If it becomes zero at point 4, the beam becomes an ellipse that is wider than it is high because $(B1 + B3)$ is less than $(B2 + B4)$ and the focus signal becomes negative. After peaking at point 2, the focus signal returns to zero just as when the objective lens is too far from the disc. Focusing signals produced in the above manner are shown in fig. 3-38. Due to its shape, this is called an S-curve, an important graph that expresses the properties of the focus signal.

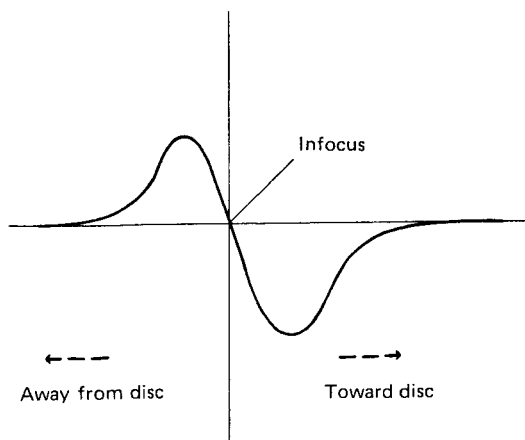

Fig.3-34 S-curve

Since the real purpose of the focus servo is to maintain the focus signal at zero, only a tiny section at the center of the S-curve appears as residual error.

Fig. 3-39 shows how the tracking signal is detected. The beam from the laser diode is divided into three beams. The ± 1 order beams on either side of the 0 order beam are used to produce the tracking signal. These two beams are, like the 0 order beam, are directed at the disc in a tiny spot. In principle, the spots of the two side beams are an equal distance from the center spot as shown in fig. 3-39. (The actual distance is much greater than that shown in the figure.) These two side beams are reflected and diffracted and returned to their respective detection elements in the photo diode. If these two elements detect the same intensity from both beams, it can be assumed that the primary (0 order) beam is correctly following the line of pits on the disc. Fig. 3-40 shows the relationship between the track and the output of each photo diode element (A, B and C).

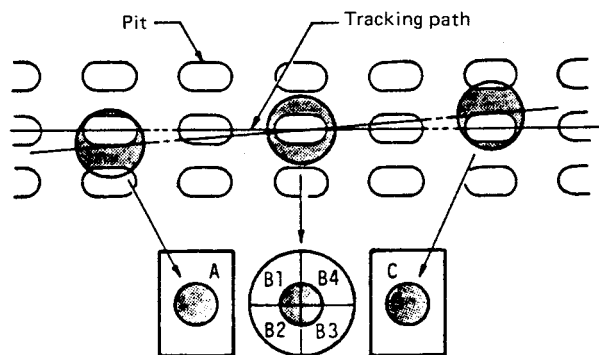

Fig.3-35 Detection of tracking error

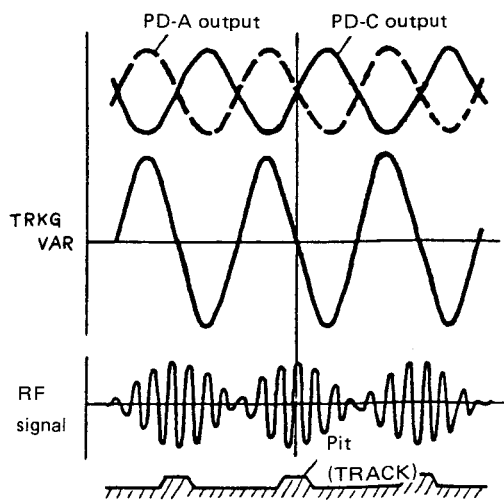

Fig.3-36 Tracking error and the RF signal

PD5010 OPERATIONS

Power on mode

1. Pickup is returned to the home position (inside SW on).
2. Load disc except when the disc tray is not completely open (open SW on). If the tray is all the way out, nothing needs to be done.
3. If the disc is properly loaded, the DISC SET LED lights, the table of contents is read, the number tracks on the disc is displayed in the 7-segment display for 4 seconds and then the first track number is displayed.
4. If no disc is in the player, the 7-segment display reads "00".
5. The spindle motor and carriage motor stop.
6. The laser diode is switched off.
7. Digital mute is switched on. Analog mute is switched on for about 2 seconds after power is switched on and then switched off.

Examples of PD-5010 Displays (for a disc having 10 tracks)

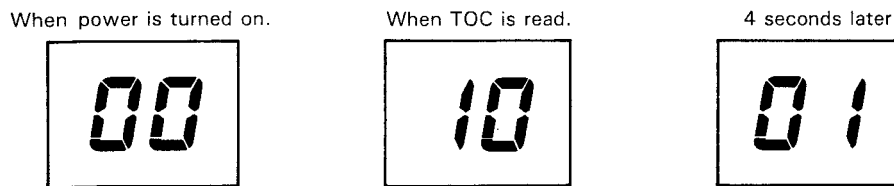

Fig. 3-37

Open/Close

1. If the open key is pressed during loading-in or the clamp mode, the program and table of contents data are cleared and the disc tray opens. If the open key is pressed during disc play, all operations are stopped and the disc tray opens. The 7-segment display reads "OP" from the time the open key is pressed until open operation is completed after which the display switches to "00".
2. If the close key is pressed during loading-out or the open mode or if the disc tray is pushed inward, loading-in is performed. The disc LED lights when the disc is properly loaded, the table of contents are read, the tracks contained in the disc are displayed by the 7-segment display and the disc stops rotating. The track display is shown for only 4 seconds after which the first track number or first programmed track number is shown.
3. If loading in/out operation is not completed after 3 seconds has passed, the unit judges that a loading problem exists and performs all steps up to that point in the reverse order. If loading-out can not be completed after 3 seconds a second time, the disc tray is stopped in its present position. This operation is always completed in the disc tray open direction.
4. Open operation is judged to be completed when the open switch is on (OPEN terminal on) and close operation when the clamp switch is on (CLMP terminal on).

Mode	Pin	OPEN	CLMP
Loading out completed		L	H
During the loading		H	H
Loading in completed		H	L

H:+5V

L:0V

Table 3-3

5. If the spindle is stopped due to a GFS abnormality or focusing problem, loading-out operation is not performed until the 7-second period needed for the disc to come to a complete stop has elapsed.
6. Pick-up home position, SPDL, STOP, LD OFF.

Play

1. If the play key is pressed during the loading or stop mode, the play LED lights, the pickup moves to the home position.
 - a) LD (laser diode) on.
 - b) Focus down for 0.3 sec., up
 - c) Detection of proper focusing and focus zero cross (SENS terminal).
 - d) Focus servo on (disc set LED ON: only PD7010 and PD-9010X)
 - e) Spindle acceleration for 0.3 sec.
 - f) Tracking servo and spindle servo closed.
 - g) Carriage servo closed.
 - h) Completion of GFS (PLL lock mode H; lock), FOK (focus lock H; lock) and monitor table of contents reading. (disc set LED ON: PD-5010 only)

After the above set-up operations have been performed, the beginning of the first track is located, digital muting is released and disc play is started.

2. Deemphasis on/off switching is automatically performed by constantly reading sub-code Q.
3. To prevent the generation of abnormal noises, digital muting is switched on if the GFS lock is released for 16 or more continuous frames, and switched off if the GFS remains locked for 16 or more continuous frames. Furthermore, if the lock is off for more than two seconds at a time the player judges that an abnormal condition exists and switches to replay operation.
4. If the FOK signal is NG (low) for 100msec. or more, the player judges that focus is not correct and switches to replay operation.
5. If the present address is equal to the previous address or the address read one second later, the player judges that skipping has occurred. The previous address is then located and disc play is resumed from that point. If the skipping is detected again at the same address, restoration processing is not conducted.
6. Replay operation
If search, play, pause or scan can not be continued due to a GFS or focus problem, all servo circuits are switched off for a moment without moving the carriage. The carriage is then driven again to locate the original address after which the player returns to the play or pause mode. This procedure is called replay operation. If a problem occurs again during replay operation, however, the player is stopped.
7. During disc play, all keys except the program keys can be used.

Pause

1. If the pause key is pressed during disc play, the pause LED lights and the player switches to the pause mode at that point. If track search is then performed, the player returns to the pause mode at the address (sec.) where search was completed. Pause is released by pressing the pause or play key.
2. If the pause key is pressed during the stop or search mode, the pause LED lights and the player returns to the pause mode at the address (sec.) where search was completed. During the stop mode, the pause LED goes out if the pause, stop or clear key is pressed.
3. Digital muting is on during the pause mode.
4. The tracking and carriage servo loops are switched off for a moment when jumping. All servo loops are closed at all other times.
5. Indicates beam movement during the pause mode.
If the pause key is pressed at point A, data is read, jump reverse (point A) is performed and data is read (point B). If the data at point B are at least one second smaller than those at point A, the disc is played. If the difference is less than one second, jump reverse is performed. Play is started at the point where the difference becomes smaller by one second or more. Jump reverse is performed at the point (point D) where the difference becomes one second or more compared with point A.
Pause key on: A... repeated
Address larger than at point A (in seconds)
When pause is released, play is resumed after performing 2 or 3 reverse track jumps. The display remains at point A until point A is passed.

Stop

1. When disc play has ended or when the stop/clear key is pressed, all operations are stopped, the pickup returns to the home position and the display shows the first track on the disc or, if the player was in the program mode, the first programmed track.
Repeat and pause are also cancelled.
2. If the stop/clear key is pressed during the stop mode, the program is cleared.

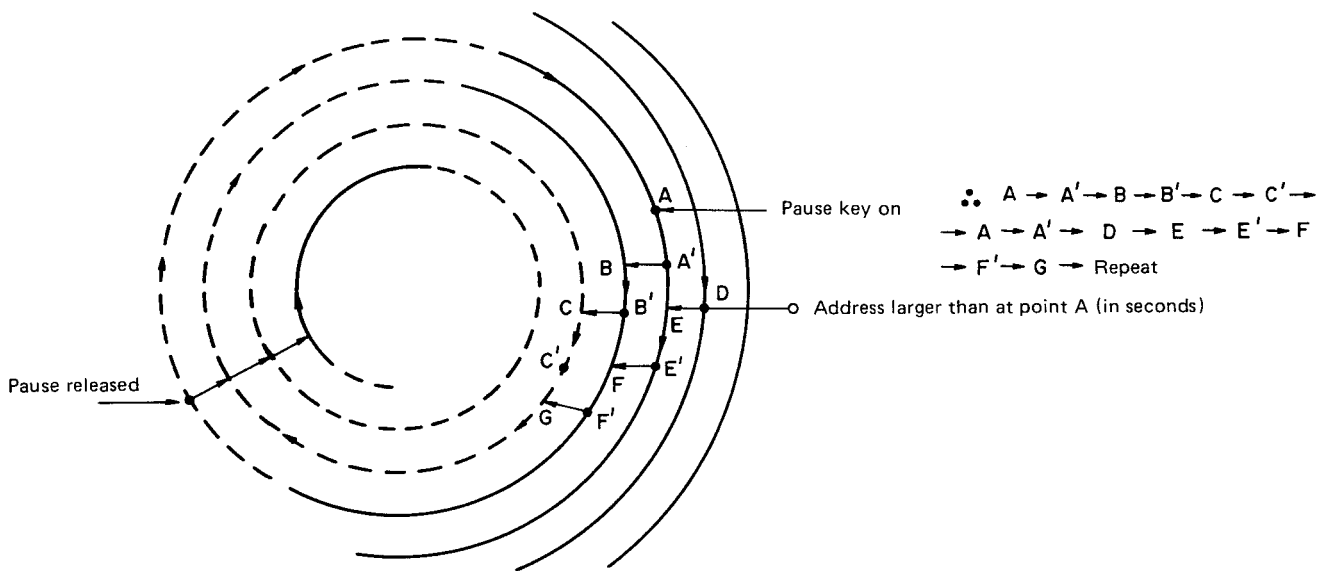

Fig. 3-38

Manual search fwd/rev

1. Operates only during the play and pause modes.
2. If the manual search-FWD or REV key is pressed during the play or pause mode, the elapsed time of the track currently being searched is shown in the 7-segment display for as long as the key is held down and forward or reverse search is conducted. The player returns to the play or pause mode when the key is released.
3. Manual search during disc play causes sound to be heard at fixed intervals (-12dB, deemphasis on). After the key is pressed, the first 4 seconds are passed over at five times normal disc play speed as the play LED slowly flashes on and off. The speed then changes to 20 times normal speed and the play LED rapidly flashes on and off.
4. Manual search during the pause mode is silent. Search speed is 60 times normal disc play speed and the play LED flashes on and off even more rapidly.
5. If manual search is used to return the pickup to the beginning of the first song, the player switches to the pause mode. If the pickup is advanced to the leadout track, the 7-segment display shows the letter "E" and the player switches to the pause mode.
6. Manual search during program play causes the pickup to move rapidly forward or backward only over the current song. If the pickup reaches the previous song, the player switches to the pause mode at the beginning of the current song. If the pickup reaches the next song, the player switches to the pause mode at the end of the current song.

How N times normal speed movement is done.

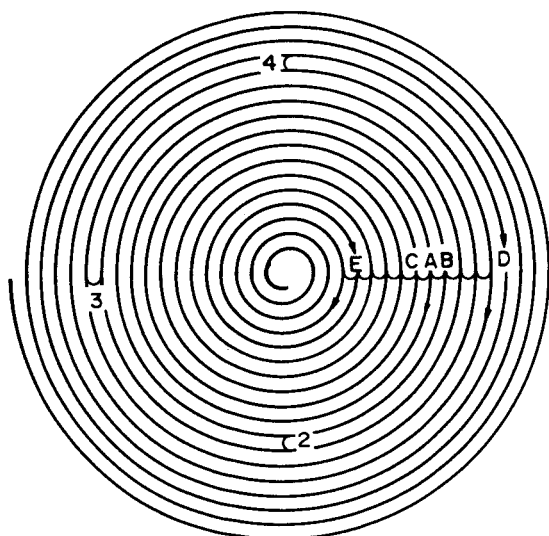
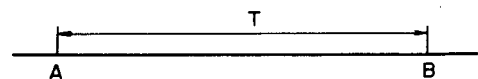

Fig. 3-39

During normal disc play, T is the amount of time required to go from point A to B (the time is about the same for movement from point C to A).



Therefore, moving to point D over the same time period required to perform forward jump four times at point A means that movement is being done at five times normal play speed. In the same manner, moving to point E over the amount of time required to perform reverse jump six times also means that movement is being done at five times normal play speed. High speed movement is performed, therefore, by altering the number of jumps and the intervals. For example, it is possible to move in the same manner to point D by using one forward jump at an interval of $t/4$.

Track Search

1. If the track search key is pressed during the play or pause mode to raise or lower the track number shown by the 7-segment display, track search is performed.
2. The pickup moves forward one track if the track search forward key is pressed once and moves ahead continuously one track at a time if the key is held down. If the track search reverse key is pressed once, the pickup returns to the beginning of the current track. If the key is held down, the pickup moves continuously back one track at a time.
3. If the table of contents has been read, forward and reverse track search is possible over the entire disc. If the table has not been read, search is possible only from track 1 through track 99.
4. During program play, track search (skip) is possible over the programmed tracks.
5. If the play key is pressed after having selected a particular track number using the track search keys during the stop mode, disc play is started from the track number shown by the 7-segment display.
6. Reverse track search is not possible while using search for the first track on the disc (or the first programmed track). Forward track search is not possible while using search for the last track on the disc (or the last programmed track).

Program Inputs

1. If a track search key is used to set the displayed track number to a particular number and then the program set key is pressed (during the stop mode), the track number shown by the 7-segment display will be programmed. At this time, the program LED lights to show that the track is now stored in the memory. For all following tracks, the program LED indicator lights for a moment to show that they have been stored. If a track number not on the disc is input, that input is automatically cleared.
2. The range over which track numbers can be specified using the track search keys is the entire disc if the table of contents has been read and from track 1 to 99 if the table has not been read. If the table has not been read, program contents will be checked after the table is read and track numbers not on the disc automatically cleared.
3. The program can contain up to 27 steps.
4. After a program has been entered, additions can be made but program checking and corrections are not possible.
5. The program can be cleared by pressing the stop/clear key when the player is in the stop mode.

Program Play

After entering a program (program LED is on), pressing the play key causes the programmed tracks to be played in order. During program play, the 7-segment display shows the number of the track currently being played. If a track search key is pressed during program play, search is possible over all programmed tracks. If a manual search key is pressed during program play, the pickup can be moved rapidly forward and backward only over the current track.

Program Clear

To clear program contents, press the open key or, during the stop mode, the stop key. Program contents will not be cleared if the stop key is pressed during program play. Program LED on

Repeat

If the repeat key is pressed during normal disc play, the repeat LED lights and the entire disc is played repeatedly. The repeat mode is cancelled by pressing the repeat, stop/clear, open/close or power key.

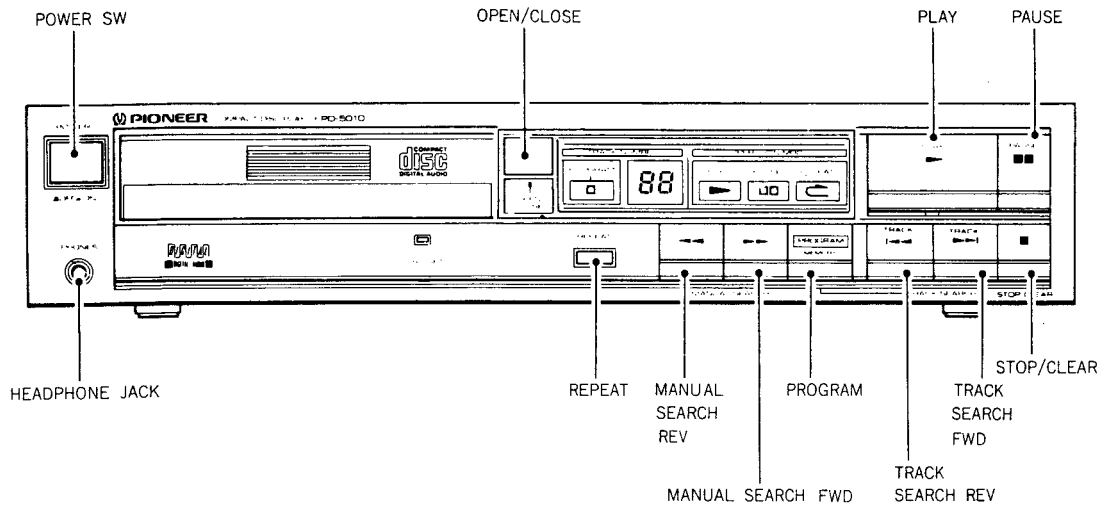

Fig. 3-40

○..... Key operation
 X..... Not key operation

KEY	OPEN / CLOSE	▶ PLAY	⏸ PAUSE	◀◀ TRACK	▶▶ TRACK	■ STOP / CLEAR	PROGRAM	◀◀ MSEARCH R	▶▶ MSEARCH F	REPEAT
Play	○	X	○	○	○	○	X	○	○	○
Pause	○	○	○	○	○	○	X	○	○	○
Stop	○	○	○	○	○	○	○	X	X	○
During the track serch	○	○	○	○	○	○	X	X	X	○
During the manual search	X	X	X	X	X	X	X	X	X	X
Loading is completed	○	○	○	○	○	○	○	X	X	○
During the loading in	○	○	○	○	○	X	X	X	X	○
During the loading out	○	○	○	X	X	X	X	X	X	○

Table 3-4

PD07010, 9010X OPERATIONS

1. Power on mode

- a) The pickup is returned to the home position (inside SW on).
- b) Loading-in except when the disc tray is completely opened (open SW on). If the tray is all the way out, nothing happens.
- c) If a disc is loaded, the disc LED lights and the table of contents is read. The number of tracks on the disc and total playing time are then displayed for four seconds after which the first track/index number is displayed.
- d) If a disc is not loaded, the player mode immediately after power is switched on is maintained.
- e) The spindle motor and carriage motor are stopped.
- f) The laser diode is switched off.
- g) Digital muting is switched on. Analog muting is switched on for about 2 seconds after power is switched on and then switched back off.

Example of PD-7010, 9010X display (for disc having 10 tracks)

When power is turned on.

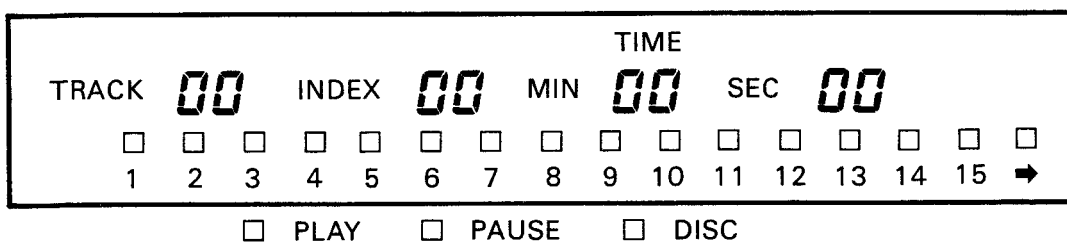

When TOC is read.

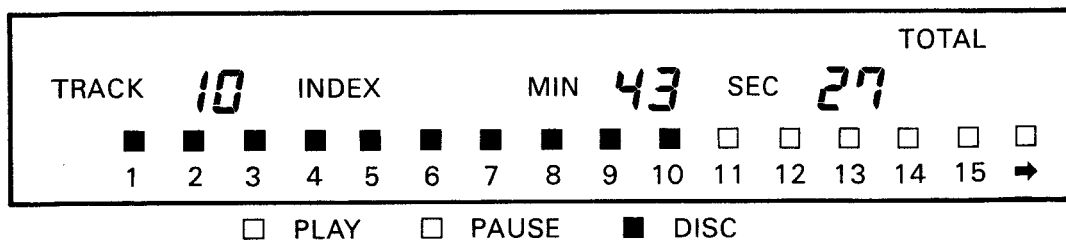

4 seconds later

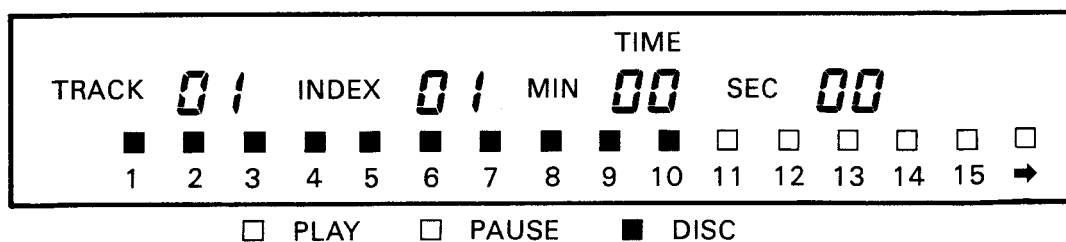

Fig. 3-41

2. Open/Close

- a) If the open key is pressed during loading-in or the clamp mode, program and table of contents data are cleared and the disc tray opens. If this key is pressed during disc play, all operations are stopped and the disc tray opens. The fluorescent display reads "OPEN" from the time the key is pressed until open operation is completed.
- b) If the close key is pressed during loading-out or the tray open mode or if the disc tray is pushed inward during the open mode, loading-in is performed. If a disc is loaded, the disc LED lights, the table of contents is read, the tracks and total playing time of the disc are displayed and the player goes to the stop mode. The track display is held for only four seconds.
- c) If loading in/out operation is not completed after 3 seconds has passed, the unit judges that a loading problem exists and performs all steps up to that point in the reverse order. If loading-out can not be completed after 3 seconds a second time, the disc tray is stopped in its present position. This operation is always completed in the disc tray open direction.
- d) Open operation is judged to be completed when the open switch is on (OPEN terminal GND) and close operation when the clamp switch is on (CLMP terminal GND).
- e) If the spindle is stopped due to a GFS abnormality or focusing problem, loading-out operation is not performed until the 7-second period needed for the disc to come to a complete stop has elapsed.
- f) Pick-up home position, SPDL, STOP, LD OFF.

Mode	Pin	OPEN	CLMP
Loading out completed		L	H
During the loading		H	H
Loading in completed		H	L

H: +5V

L: 0V

Table 3-5

Play

1. If the play key is pressed during the loading or stop mode, the play LED lights, the pickup moves to the home position.
 - a) LD (laser diode) on.
 - b) Focus down for 0.3 sec., up
 - c) Focus servo switched on, disc set LED switched on.
 - d) Spindle acceleration for 0.3 sec.
 - e) Tracking servo and spindle servo closed.
 - f) Carriage servo closed.
 - g) Completion of GFS (PLL lock mode H; lock), FOK (focus lock H; lock) and reading of monitor table of contents.

After the above set-up operations have been performed, the beginning of the first track is located, digital muting is released and disc play is started.

2. Deemphasis on/off switching is automatically performed by constantly reading sub-code Q.
3. To prevent the generation of abnormal noises, digital muting is switched on if the GFS lock is released for 16 or more continuous frames (about 2.2 msec.). Muting is switched back off after GFS has remained locked for at least 16 continuous frames. If the lock is off for more than 2 seconds at one time, the player judges that an abnormal situation exists and switches to replay operation.
4. If the FOK signal is NG (low) for 100msec. or more, the player judges that focus is not correct and switches to replay operation.
5. If the present address is equal to the previous address or the address read one second later, the player judges that skipping has occurred. The previous address is then located and disc play is resumed from that point. If the skipping is detected again at the same address, restoration processing is not conducted.
6. Replay operation
If search, play, pause or scan can not be continued due to a GFS or focus problem, all servo circuits are switched off for a moment without moving the carriage. The carriage is then driven again to locate the original address after which the player returns to the play or pause mode. This procedure is called replay operation. If a problem occurs again during replay operation, however, the player is stopped.
7. During disc play, all keys except the program keys can be used.

Pause

1. If the pause key is pressed during disc play, the pause LED lights and the player switches to the pause mode at that point. If track search is then performed, the player returns to the pause mode at the address (sec.) where search was completed. Pause is released by pressing the pause or play key.
2. If the pause key is pressed during the stop or search mode, the pause LED lights and the player returns to the pause mode at the address (sec.) where search was completed. During the stop mode, the pause LED goes out if the pause, stop or clear key is pressed.
3. Digital muting is on during the pause mode.
4. The tracking and carriage servo loops are switched off for a moment when jumping. All servo loops are closed at all other times.

5. Indicates beam movement during the pause mode.

If the pause key is pressed at point A, data is read, jump reverse (point A) is performed and data is read (point B). If the data at point B are at least one second smaller than those at point A, the disc is played. If the difference is less than one second, jump reverse is performed. Jump reverse is performed at the point (point D) where the difference becomes one second or more compared with point A.

Pause key on: A... repeated

Address larger than at point A (in seconds)

When pause is released, play is resumed after performing 2 or 3 reverse track jumps. The display remains at point A until point A is passed.

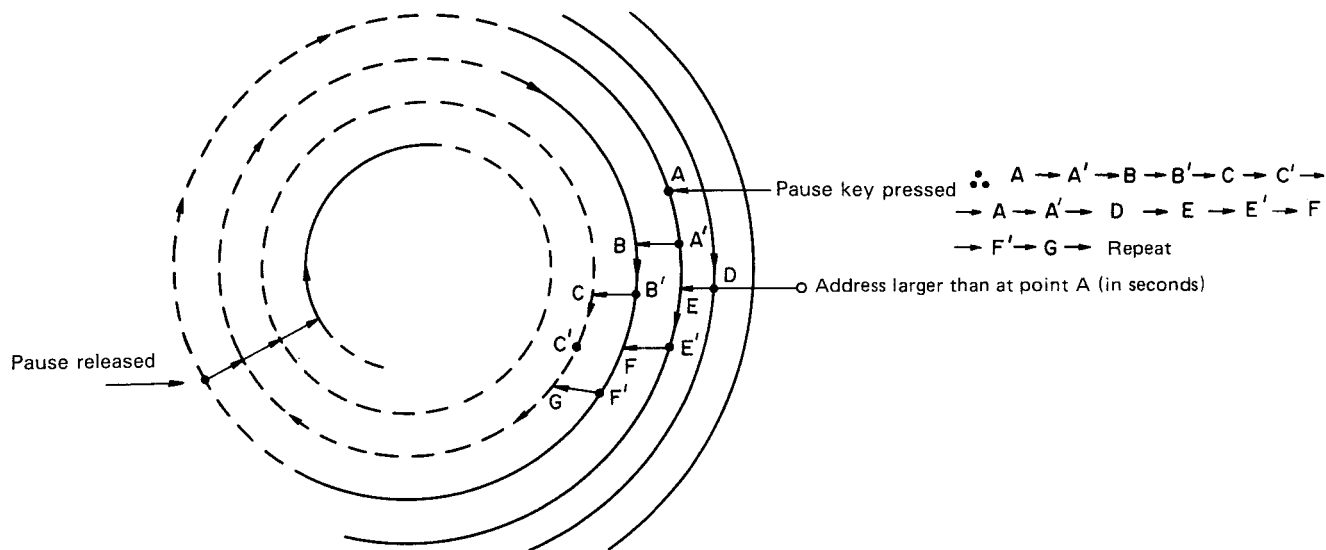

Fig. 3-42

Stop

1. When disc play has ended or when the stop/clear key is pressed, all operations are stopped, the pickup returns to the home position and the display shows the first track on the disc or, if the player was in the program mode, the first programmed track. Repeat and pause are also cancelled.
2. If the stop/clear key is pressed during the stop mode, the program is cleared.

Manual search fwd/rev

1. Operates only during the play and pause modes.
2. If the manual search-FWD or REV key is pressed during the play or pause mode, the elapsed time of the track currently being searched is displayed for as long as the key is held down and forward or reverse search is conducted. The player returns to the play or pause mode when the key is released.
3. Manual search during disc play causes sound to be heard at fixed intervals (-12dB, deemphasis on). After the key is pressed, the first 4 seconds are passed over at five times normal disc play speed as the play LED slowly flashes on and off. The speed then changes to 20 times normal speed and the play LED rapidly flashes on and off.
4. Manual search during the pause mode is silent. Search speed is 60 times normal disc play speed and the play LED flashes on and off even more rapidly.
5. If manual search is used to return the pickup to the beginning of the first song, the player switches to the pause mode. If the pickup is advanced to the leadout track, the display shows the word "END" and the player switches to the pause mode.
6. Manual search during program play causes the pickup to move rapidly forward or backward only over the current song. If the pickup reaches the previous song, the player switches to the pause mode at the beginning of the current song.

How N times normal speed movement is done.

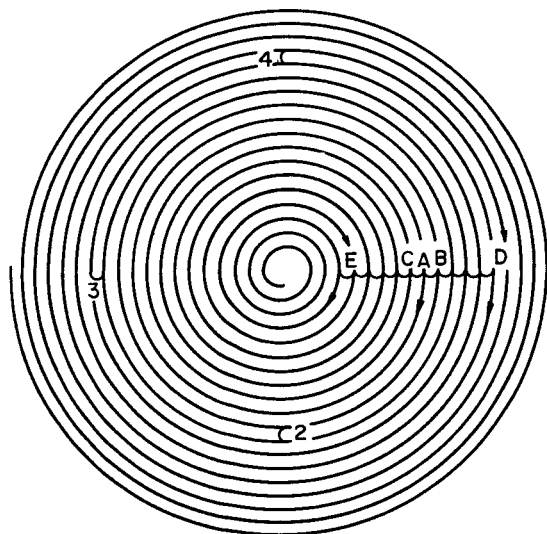
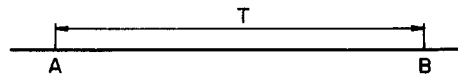

Fig. 3-43

During normal disc play, T is the amount of time required to go from point A to B (the time is about the same for movement from point C to A).



Therefore, moving to point D over the same time period required to perform forward jump four times at point A means that movement is being done at five times normal play speed. In the same manner, moving to point E over the amount of time required to perform reverse jump six times also means that movement is being done at five times normal play speed. High speed movement is performed, therefore, by altering the number of jumps and the intervals. For example, it is possible to move in the same manner to point D by using one forward jump at an interval of $t/4$.

Track Search

1. If the track search key is pressed during the play or pause mode to raise or lower the track number shown by the fluorescent display, track search is performed. The play LED slowly flashes on and off during search operation to show that search is being performed. The play LED returns to normal when search is finished.
2. The pickup moves forward one track if the track search forward key is pressed once and moves ahead continuously one track at a time if the key is held down. If the track search reverse key is pressed once, the pickup returns to the beginning of the current track. If the key is held down, the pickup moves continuously back one track at a time.
3. If the table of contents has been read, forward and reverse track search is possible over the entire disc. If the table has not been read, search is possible only from track 1 through track 99.
4. During program play, track search (skip) is possible over the programmed tracks.
5. If the play key is pressed after having selected a particular track number using the track search keys during the stop mode, disc play is started from the track number shown by the fluorescent display.
6. Reverse track search is not possible while using search for the first track on the disc (or the first programmed track). Forward track search is not possible while using search for the last track on the disc (or the last programmed track).

Program Play

1. If the play key is pressed after loading a program (program RAM-LED on), the programmed sequence of tracks will be played in order.

During program play, the number of the track currently being played is displayed. If a track search key is pressed during program play, search is possible over all programmed tracks. If a manual search key is pressed during program play, the pickup can be moved rapidly forward and backward only over the current track.

Program Clear

To clear program contents, press the open key or, during the stop mode, the stop key. Program contents will not be cleared if the stop key is pressed during program play. Program LED on

Repeat

If the repeat key is pressed during normal disc play, the repeat LED flashes on and off and the entire disc is played repeatedly. If this key is pressed during program play, all programmed tracks are played repeatedly. The repeat mode is cancelled by pressing the repeat, stop/clear, open/close or power key.

Time

The time key is pressed to switch between the elapsed time and remaining time display modes.

Keys

The 0-9 numeric keys are used for direct track selection and program entries.

PROGRAMMING

Program Input

1. Program Entries

Program input is possible only during the stop mode. A desired track number is specified by the numeric keys and then the program key is pressed to store that number in the memory. If the table of contents has been read, track numbers not on the disc will not be accepted. If the table has not been read (for example, when the tray is still open), all track numbers will be accepted. Any numbers not on the disc will then be cleared automatically after the table of contents has been read.

As tracks are programmed, the total playing time of the program up to that point is displayed. Up to 32 steps can be stored in the memory.

2. Program Checking

After a program has been entered, the programmed track numbers can be displayed one by one in order by pressing the track key when the player is in the stop mode.

3. Program Play

When a program has been entered, pressing the play key causes the programmed tracks to be played in order. During program play, it is possible to add more tracks by performing the programming entry procedure but it is not possible to change or delete program entries.

4. Program Clear

Program contents are cleared if the open/close key is pressed. During program play, pressing the stop key stops disc play but it does not clear program contents. The stop key must be pressed once more to clear program contents as well.

Repeat

When the repeat key is pressed during normal disc play, the repeat indicator lights and the entire disc is played repeatedly. During program disc play, the programmed tracks are played repeatedly. Repeat is cancelled if the repeat key is pressed once again.

EXAMPLE During the stop mode

TRACK		01		INDEX	01		MIN	00		SEC	00		TIME	
■	■	■	■	■	■	■	■	■	■	■	■	■	■	■
1	2	3	4	5	6	7	8	9	10	11	12	13	14	15 →
□ PLAY		□ PAUSE		■ DISC										

Pause for step 3

<PAUSE>

TRACK		08		INDEX	02		MIN	08		SEC	28		TOTAL	
□	□	□	■	□	□	■	□	□	□	□	□	□	□	□
1	2	3	4	5	6	7	8	9	10	11	12	13	14	15 →
□ PLAY		■ PAUSE		■ DISC										

Track 5 for step 1

TRACK		05		INDEX			MIN			SEC			TOTAL	
■	■	■	■	■	■	■	■	■	■	■	■	■	■	■
1	2	3	4	5	6	7	8	9	10	11	12	13	14	15 →
□ PLAY		□ PAUSE		■ DISC										

<PROGRAM>

TRACK		PA		INDEX	03		MIN	08		SEC	28		TOTAL	
□	□	□	□	■	□	■	□	□	□	□	□	□	□	□
1	2	3	4	5	6	7	8	9	10	11	12	13	14	15 →
□ PLAY		□ PAUSE		■ DISC										

<PROGRAM>

TRACK		05		INDEX	01		MIN	04		SEC	15		TOTAL	
□	□	□	□	■	□	□	□	□	□	□	□	□	□	□
1	2	3	4	5	6	7	8	9	10	11	12	13	14	15 →
□ PLAY		□ PAUSE		■ DISC										

Track 2 for step 4

TRACK		02		INDEX			MIN			SEC			TOTAL	
□	□	□	□	■	□	■	□	□	□	□	□	□	□	□
1	2	3	4	5	6	7	8	9	10	11	12	13	14	15 →
□ PLAY		□ PAUSE		■ DISC										

Track 8 for step 2

TRACK		08		INDEX			MIN			SEC			TOTAL	
□	□	□	□	■	□	□	□	□	□	□	□	□	□	□
1	2	3	4	5	6	7	8	9	10	11	12	13	14	15 →
□ PLAY		□ PAUSE		■ DISC										

<PROGRAM>

TRACK		02		INDEX	04		MIN	11		SEC	43		TOTAL	
□	■	□	□	■	□	■	□	□	□	□	□	□	□	□
1	2	3	4	5	6	7	8	9	10	11	12	13	14	15 →
□ PLAY		□ PAUSE		■ DISC										

<PROGRAM>

TRACK		08		INDEX	02		MIN	08		SEC	28		TOTAL	
□	□	□	□	■	□	■	□	□	□	□	□	□	□	□
1	2	3	4	5	6	7	8	9	10	11	12	13	14	15 →
□ PLAY		□ PAUSE		■ DISC										

Programming is completed and the total playing time of the three tracks is 11 min. 43 sec.

Fig. 3-44

Index Search

During the play or pause mode, pressing the INDEX FWD key moves the pickup ahead to the beginning of the next index. The INDEX REV key moves the pickup back to the beginning of the present index. Using the INDEX FWD/REV keys during search causes the pickup to move to the index following (or preceding) the index currently being searched.

EXAMPLE

To search track 3 of a disc containing 10 tracks.

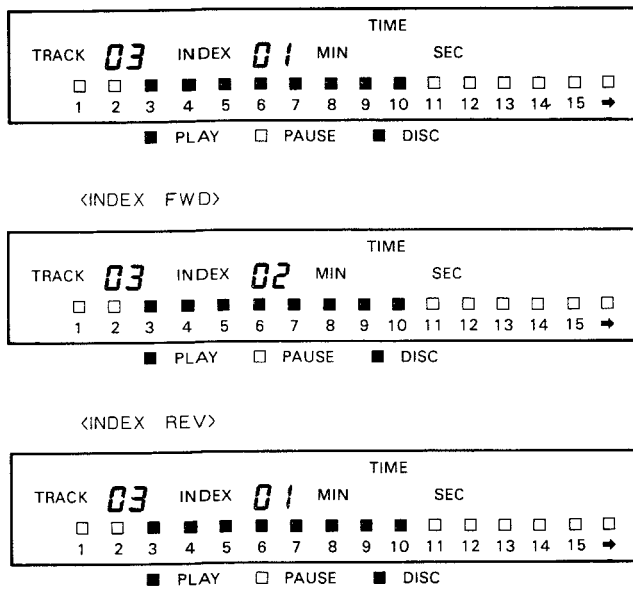

Index search is not possible during program disc play.

Fig. 3-45

Display Functions

Pressing the time key switches the display progressively through three modes: time, remain and total. If a program has been entered, the remain and total modes show the remaining and total playing time of all programmed tracks. If the time key is pressed after entering a track number using the numeric keys, the total playing time of that track is displayed for four seconds.

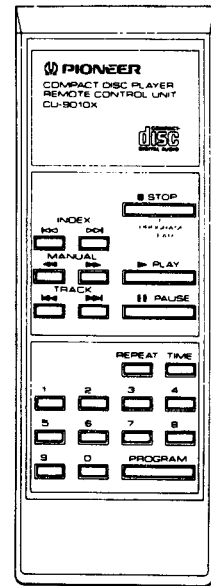

Fig. 3-46

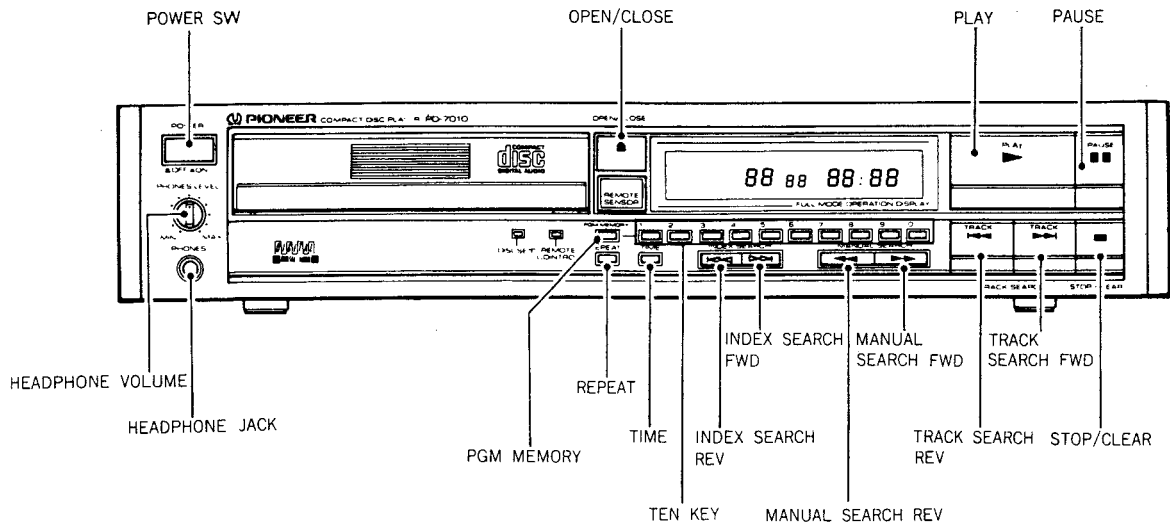

Fig. 3-47

○.....Key operation
 X.....Not key operation

KEY	OPEN / CLOSE	▶ PLAY	⏸ PAUSE	⏮ TRACK	⏭ TRACK	■ STOP / CLEAR	PROGRAM	⏮ MSEARCHR	⏭ MSEARCHF	⏮ INSEARCHR	⏭ IN.S.F	TIME	10 KEY	REPEAT
Play	○	X	○	○	○	○	X	○	○	○	○	○	○	○
Pause	○	○	○	○	○	○	X	○	○	○	○	○	○	○
Stop	○	○	○	○	○	○	○	X	X	○	○	○	○	○
During the track serch	○	X	○	○	○	○	X	X	X	○	○	○	○	○
During the manual search	X	X	X	X	X	X	X	X	X	X	X	X	X	X
Loading is completed	○	○	○	○	○	○	○	X	X	○	○	○	○	○
During the loading in	○	○	○	○	○	X	X	X	X	○	○	○	○	○
During the loading out	○	○	○	X	X	X	X	X	X	X	X	○	X	○
During the index serch	○	X	○	○	○	○	X	X	X	○	○	○	○	○

Table 3-6

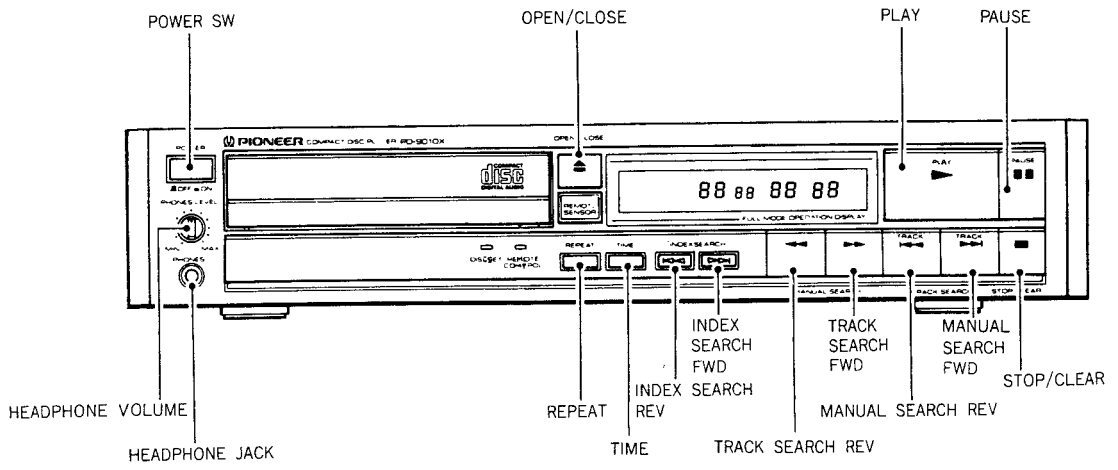

Fig. 3-48

○.....Key operation
 X.....Not key operation

KEY Condition	OPEN CLOSE	▶ PLAY	⏸ PAUSE	⏮ TRACK	⏭ TRACK	■ STOP/ CLEAR	PROGRAM	⏮ MSEARCH-R	⏭ MSEARCH-F	⏮ INSEARCH-R	⏭ IN.S.F	TIME	10 KEY	REPEAT
Play	○	X	○	○	○	○	X	○	○	○	○	○	○	○
Pause	○	○	○	○	○	○	X	○	○	○	○	○	○	○
Stop	○	○	○	○	○	○	○	X	X	○	○	○	○	○
During the track serch	○	X	○	○	○	○	X	X	X	○	○	○	○	○
During the manual search	X	X	X	X	X	X	X	X	X	X	X	X	X	X
Loading is complated	○	○	○	○	○	○	○	X	X	○	○	○	○	○
During the loading in	○	○	○	○	○	X	X	X	X	○	○	○	○	○
During the loading out	○	○	○	X	X	X	X	X	X	X	X	○	X	○
During the index serch	○	X	○	○	○	○	X	X	X	○	○	○	○	○

Table 3-7