

Service Manual

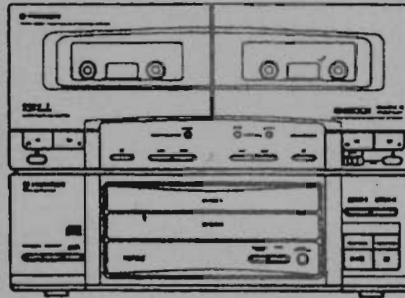

ORDER NO.
ARP2647

CASSETTE DECK TWIN CD

PDC-P630T

PDC-P530T

PDC-P630T AND PDC-P530T HAVE THE FOLLOWING :

Type	Model		Power Requirement	Remarks
	PDC-P630T	PDC-P530T		
AEBM	○	-	AC power supplied from power transformer's secondary of other system component.	
AD	○	-		
ADL	-	○		

● This manual is applicable to the following: PDC-P630T/AEBM and AD; PDC-P530T/ADL.

● For the following: PDC-P630T/AD and PDC-P530T/ADL, refer to page 49.

● These products are systems components.

Each of these products does not function properly when independent; to avoid malfunctions, be sure to connect it to the prescribed system component (s), otherwise damage may result.

These products' instructions are contained within the instruction manual of the related system component (s).

The manual is packed with those component (s).

These products' accessories etc. are packed with their related component (s).

CONTENTS

1. SAFETY INFORMATION	2	6. ADJUSTMENTS	35
2. DISASSEMBLY	3	7. IC INFORMATION	48
3. EXPLODED VIEWS, PACKING AND PARTS LIST	4	8. FOR PDC-P630T/AD AND PDC-P530T/ADL	49
4. SCHEMATIC AND PCB CONNECTION DIAGRAMS	17	9. PANEL FACILITIES	51
5. PCB PARTS LIST	33	10. SPECIFICATIONS	52

2. DISASSEMBLY

● Checking the CD player operations

1. Remove the Bonnet.
2. Remove screws (A) which hold the front panel and the binder which holds lead wires. (See Fig. 2 - 1.)
3. Pull the front panel towards you. (See Fig. 2 - 1.)

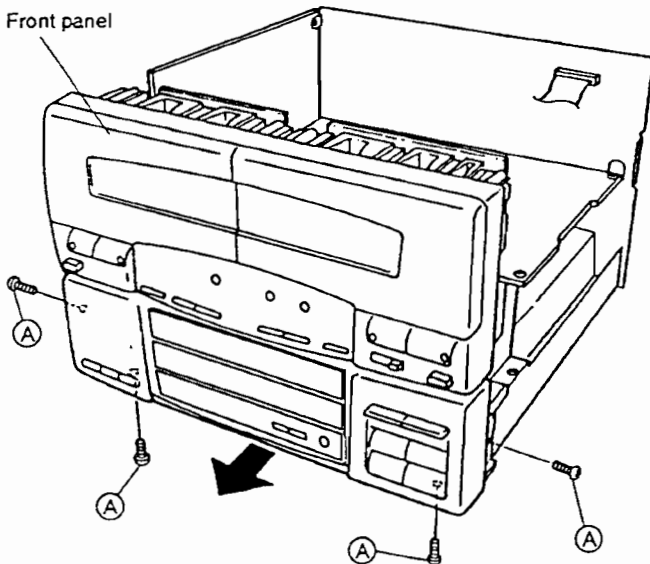

Fig. 2-1

4. Turn the front panel to the left. (See Fig. 2 - 2.)
5. Remove screws (B) which hold the MAIN unit. (See Fig. 2 - 2.)

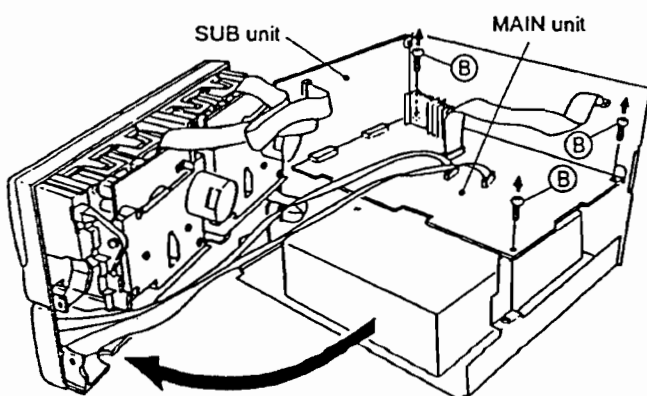

Fig. 2-2

6. Remove the MAIN unit from the SUB unit and set it on its edge. (See Fig. 2 - 3.)
7. In this status check the operations of the CD player.

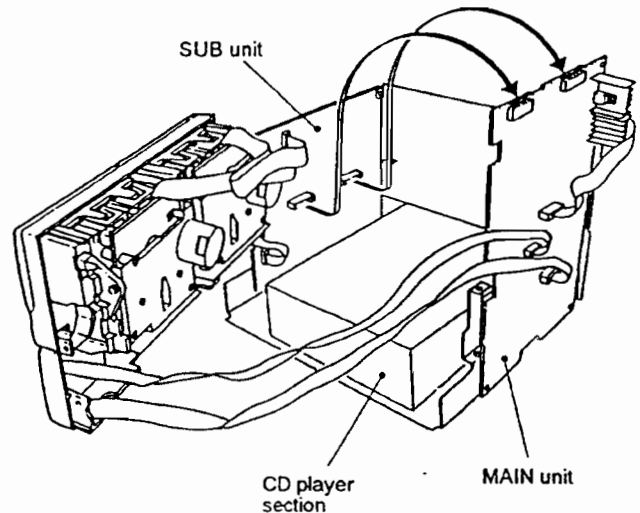

Fig. 2-3

3. EXPLODED VIEWS, PACKING AND PARTS LIST

NOTES:

- Parts marked by "NSP" are generally unavailable because they are not in our Master Spare Parts List.
- The Δ mark found on some component parts indicates the importance of the safety factor of the part. Therefore, when replacing, be sure to use parts of identical designation.
- Parts marked by "⊙" are not always kept in stock. Their delivery time may be longer than usual or they may be unavailable.

3.1 PACKING

Parts List

Mark No.	Description	Part No.
1	Pad R	RHA1122
2	Pad F	RHA1121
3	Packing sheet	RHC1021
4	Packing case	RHG1412
5	Caution card	RRN1001

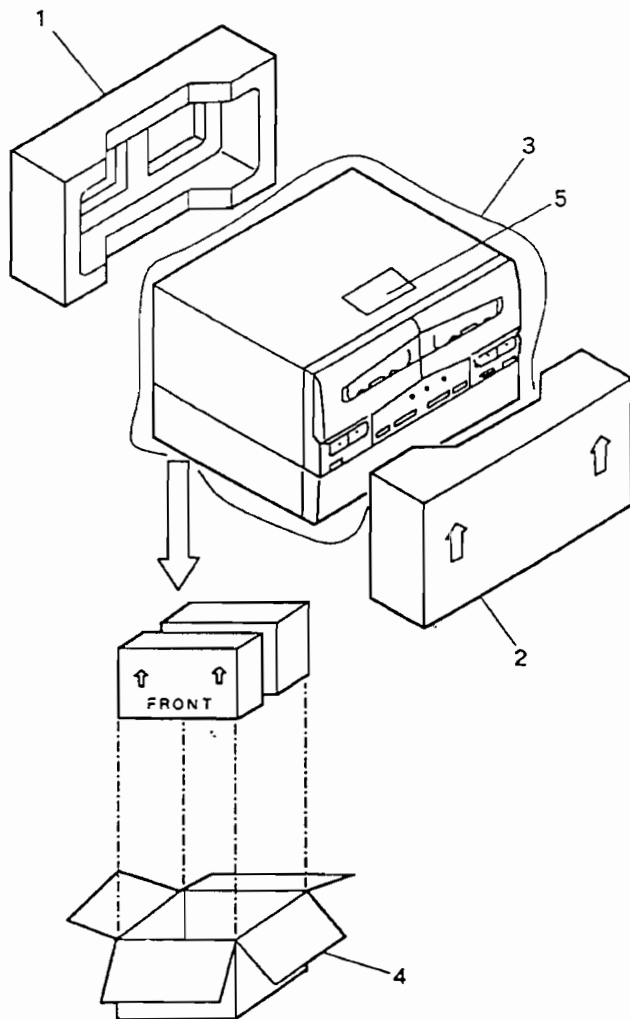

3.2 EXTERIOR

Parts List

Mark No.	Description	Part No.
1	MAIN UNIT	RWZ2858
2	Connector assembly (17P)	RKP1504
3	Cushion	REB1004
4	Door lens L	RAH2145
5	Door lens R	RAH2146
6	Bonnet	REA1046
7	Door panel R	REA1044
8	Door panel L	REA1043
9	Screw	BBZ30P060FMC
10	SUB UNIT	RWZ2859
11	Screw	BBZ30P080FZK
12	Screw	BBZ30P080FMC
13	Tray name plate 1	RAH2157
14	Tray name plate 2	RAH2158
101	
102	
103	
104	
NSP 105	Chassis	RNB1071
NSP 106	Angle	RNE1497
NSP 107	Bracket	RNE1498
108	
109	
110	
NSP 111	PC support B	VEC1179
NSP 112	Twin tray mechanism assembly	PXA1481
NSP 113	Rear panel	RNA1638
NSP 114	Binder	PEC-107
NSP 115	Wire (5P)	D20PY0520E

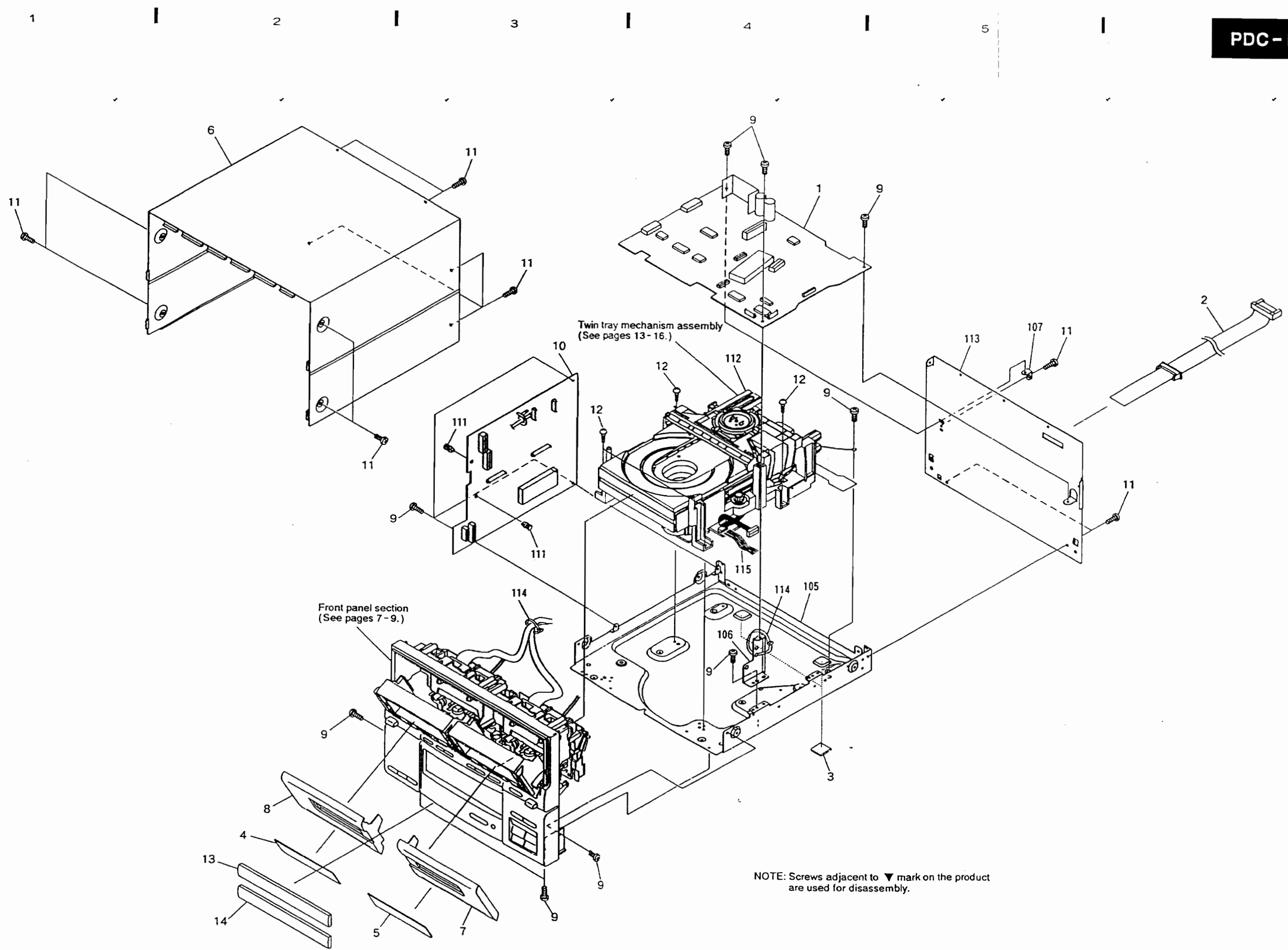

3.3 FRONT PANEL SECTION

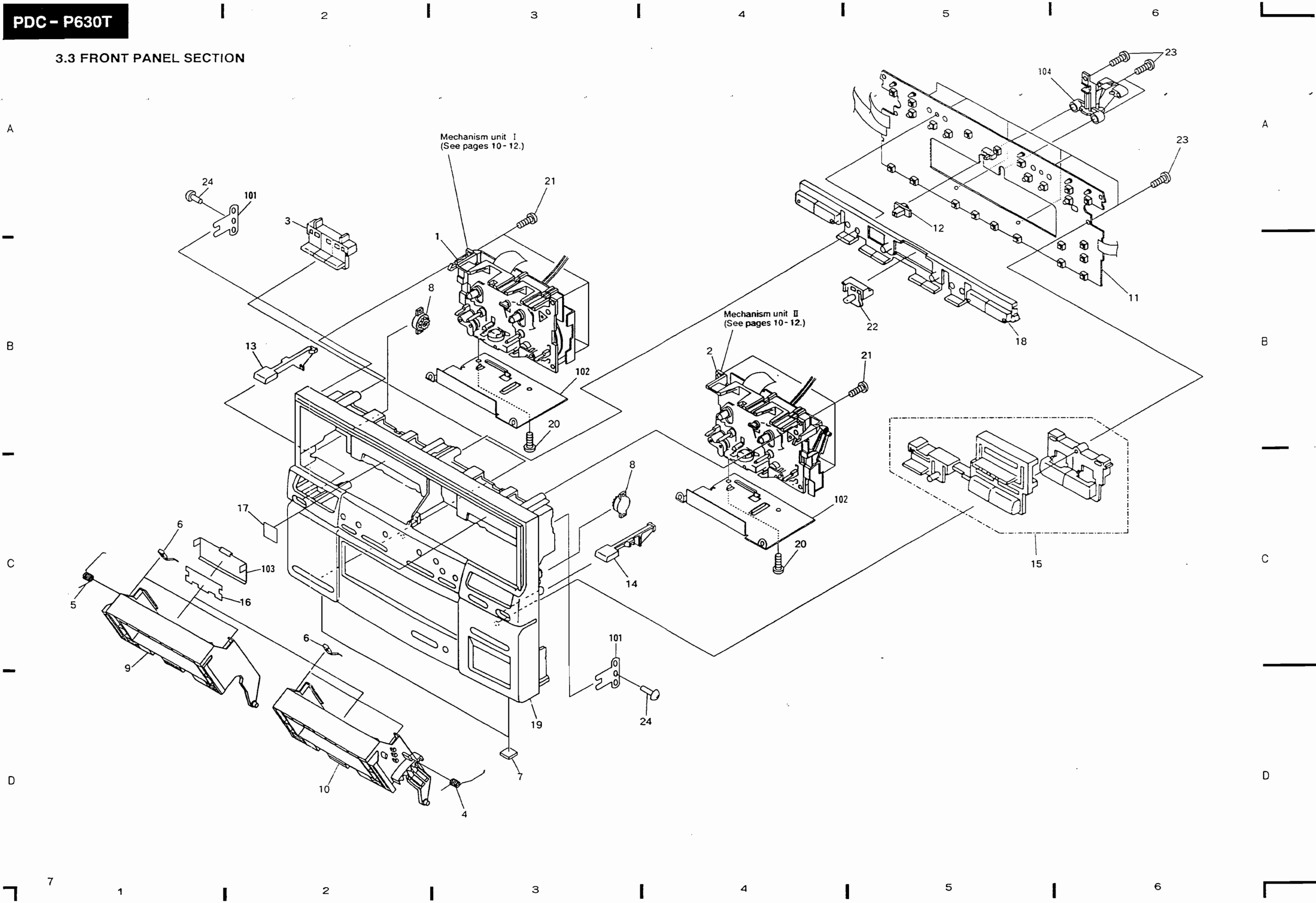

Parts List

Mark	No.	Description	Part No.	Mark	No.	Description	Part No.
⊙	1	Mechanism unit I	RYM1189	NSP	101	Bonnet stay	RNE1587
⊙	2	Mechanism unit II	RYM1190	NSP	102	Mechanism shield plate	RNE1586
	3	CD knob T	RAC1759	NSP	103	Spot lens	RNK1880
	4	Eject spring R	RBH1332	NSP	104	Center bracket	RNK1881
	5	Eject spring L	RBH1331				
	6	Half pressure spring	RBK1004				
	7	Cushion	REB1004				
	8	Damper assembly	VXA1153				
	9	Door pocket L	RNK1878				
	10	Door pocket R	RNK1879				
	11	CONT UNIT	RWZ2868				
	12	Slide knob	RAC1641				
	13	Eject knob L(▲)	RAC1754				
	14	Eject knob R(▲)	RAC1755				
	15	Play knob	RAC1761				
	16	DIND UNIT	RWZ2865				
	17	Indicator	REE-113				
	18	Deck knob assembly	RXA1529				
	19	Front panel	RNT1162				
	20	Screw	BBZ26P050FMC				
	21	Screw	BBZ30P080FMC				
	22	REC knob	RAC1760				
	23	Screw	BPZ30P100FMC				
	24	Screw	BBZ30P080FZK				

3.4 DECK SECTION

MECHANISM UNIT I (RYM1189), II (RYM1190)

Parts List

Mark	No.	Description	Part No.	Mark	No.	Description	Part No.
	1	Head holder assembly (I Mecha. only)	RXA1500		42	Spacer	RNK1822
	1	Head holder assembly (II Mecha. only)	RXA1477		43	Motor assembly	RXM1062
	2	Head frame	RNK1715		44	
	3	Head lever	RNK1716		45	Main belt	REB1159
	4	Azimuth spring	RBK1006		46	PC board	RNP1348
	5	Assist arm assembly	RXA1401		47	Housing (I Mecha. only)	RKP1396
	6	Head arm gear	RNK1717		47	Housing (II Mecha. only)	RKP1397
	7	Cassette spring	RBK1039		48	Eject lever L (I Mecha. only)	RNK1831
	8	Eject lock	RNK1718		48	Eject lever R (II Mecha. only)	RNK1811
	9	Reel cap	RNK1719		49	Collar	RNK1704
	10	Arm pinch assembly L	RXA1403		50	Head wire (I Mecha. only)	RKP1499
	11	Head base	RNE1437		50	Head wire (II Mecha. only)	RKP1500
	12	Arm pinch assembly R	RXA1404		51	Spring	RBH1282
	13	Play arm assembly L	RXA1866		52	Spring	RBH1283
	14	Play gear	RNK1867		53	Spring	RBH1284
	15	Play arm assembly R	RXA1868		54	Spring	RBH1286
	16	OS chassis	RXA1411		55	Spring	RBH1288
	17	Sub reel assembly L	RXA1407		56	Spring	RBH1291
	18	Solenoid	RXP1020		57	Spring	RBH1285
	19	Wire	RDC1006		58	Spring	RBH1287
	20	RVS arm	RNK1721		59	Spring	RBH1289
	21	FF gear	RNK1723		60	Spring	RBH1290
	22	FR arm assembly	RXA1412		61	Spring	RBH1292
	23	FR pulley assembly	RXA1413		62	FWR spring	RBH1061
	24	FR belt	REB1158		63	FWF spring	RBH1325
	25	Shaft holder	RNG1048		64	Spring(L) (I Mecha. only)	RBH1319
	26	Flywheel assembly L	RXA1423		64	Spring(R) (II Mecha. only)	RBH1320
	27	Shaft holder	RNG1005		65	Azimuth screw	RBA1023
	28	Brake arm	RNK1724		66	U bind screw	RBA1027
	29	Sub reel assembly R	RXA1408		67	Screw	RBA1030
	30	Trigger arm	RNK1722		68	Screw	PCZ20P040FMC
	31	Cam gear	RNK1725		69	Screw	RBA1093
	32	Shaft holder	RNG1049		70	Screw	RBA1094
	33	Flywheel assembly R	RXA1424		71	Screw	RBA1100
	34	Shaft holder	RNG1004		72	Screw	RBA1095
	35	Wire(14P) (I Mecha. only)	RDD1247		73	Spacer	RNK1905
	35	Wire(14P) (II Mecha. only)	RDD1217		74	Washer	RBFI046
	36			75	Washer	WA26D047D013
	37	PC board	RNP1430				
	38	Mode switch	RSN1022				
	39	Leaf switch	RSN1019				
	40	Hoic IC	DN6851A				
	41	FW bracket	RNE1438				
				NSP	101	Wire holder	RNK1683
				NSP	102	Jumper	RDD1012

A

B

C

D

A

B

C

D

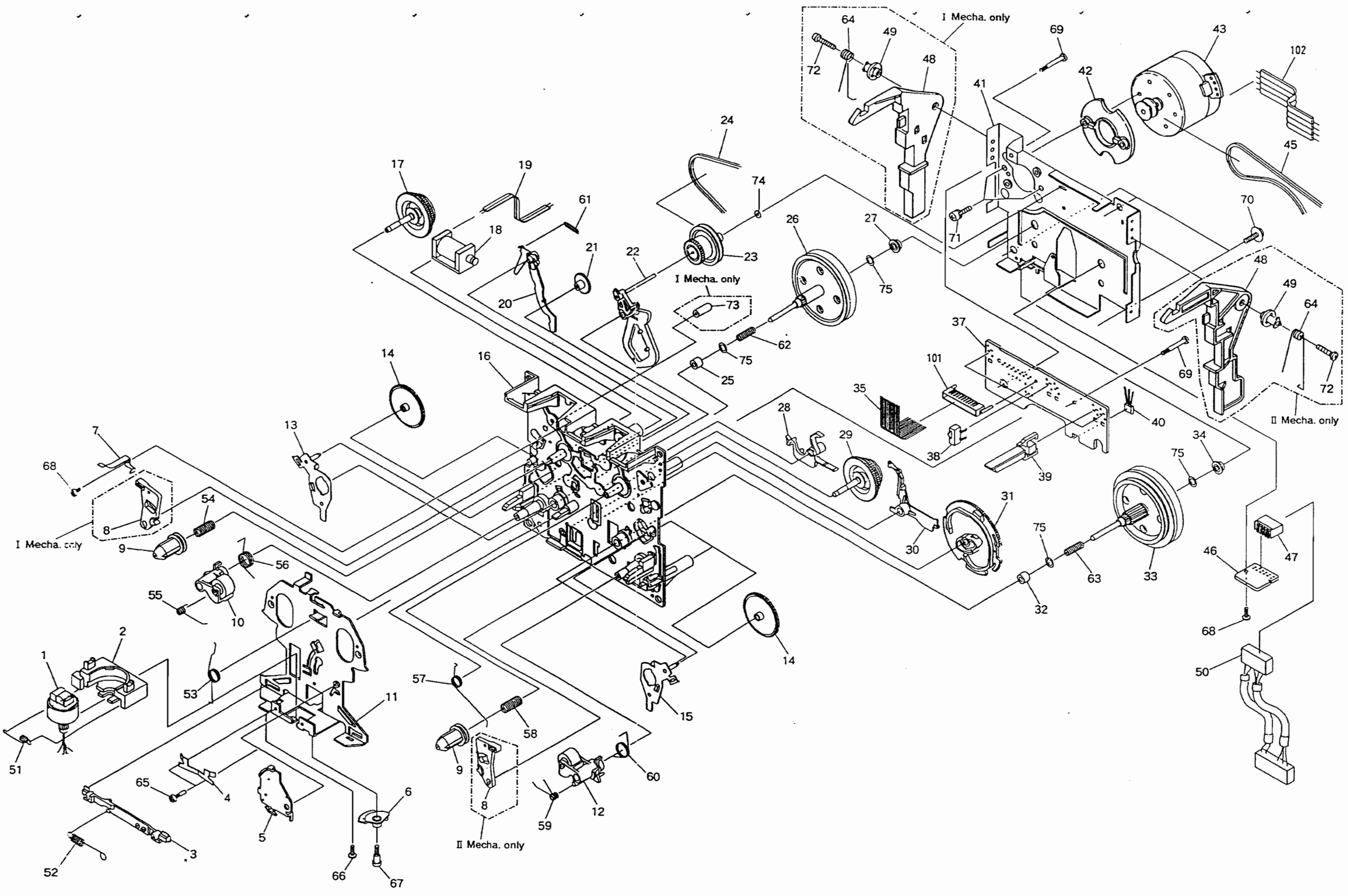

1

2

3

4

5

6

3.5 TWIN TRAY MECHANISM SECTION

A

B

C

D

A

B

C

D

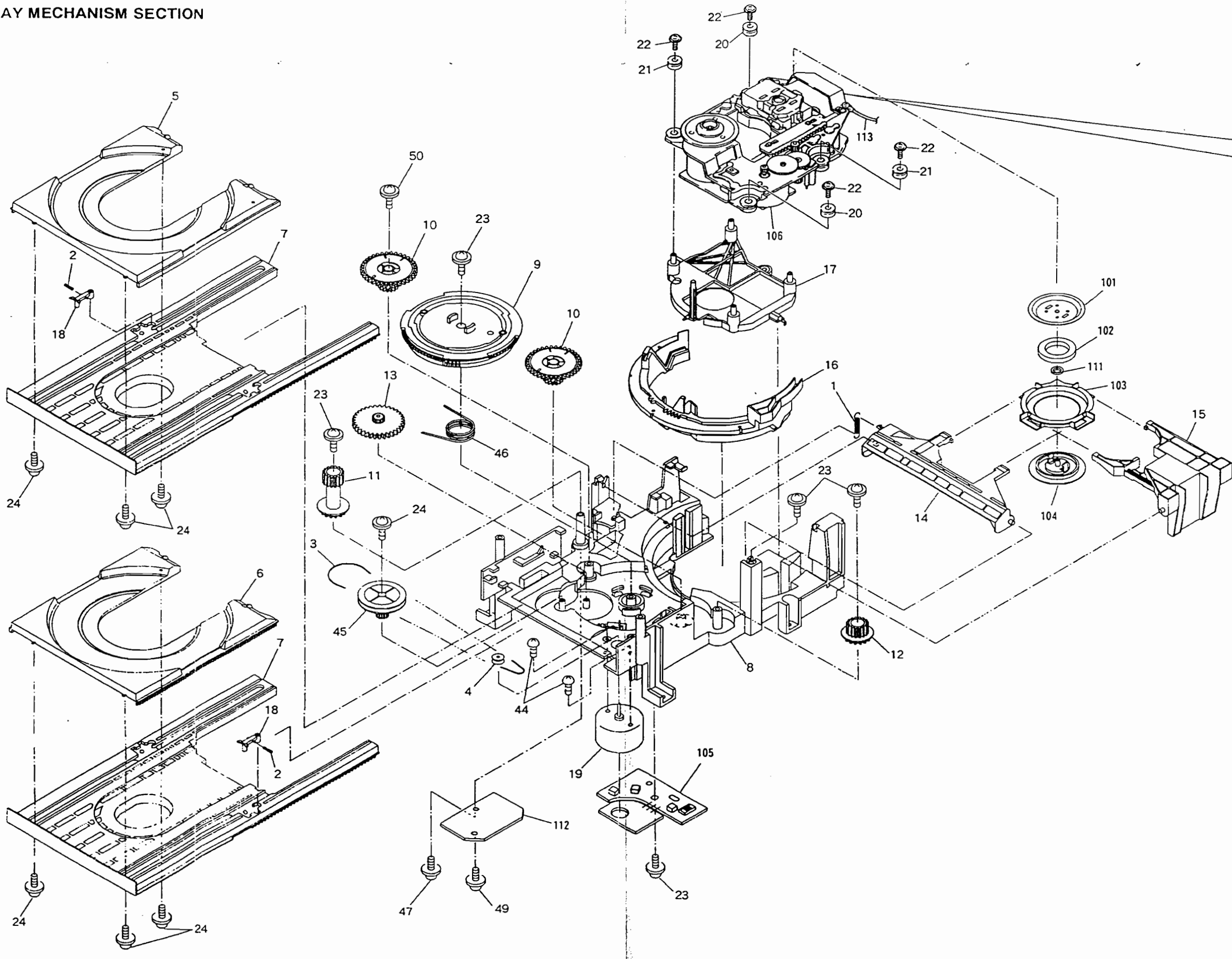

I
C

D

E

F

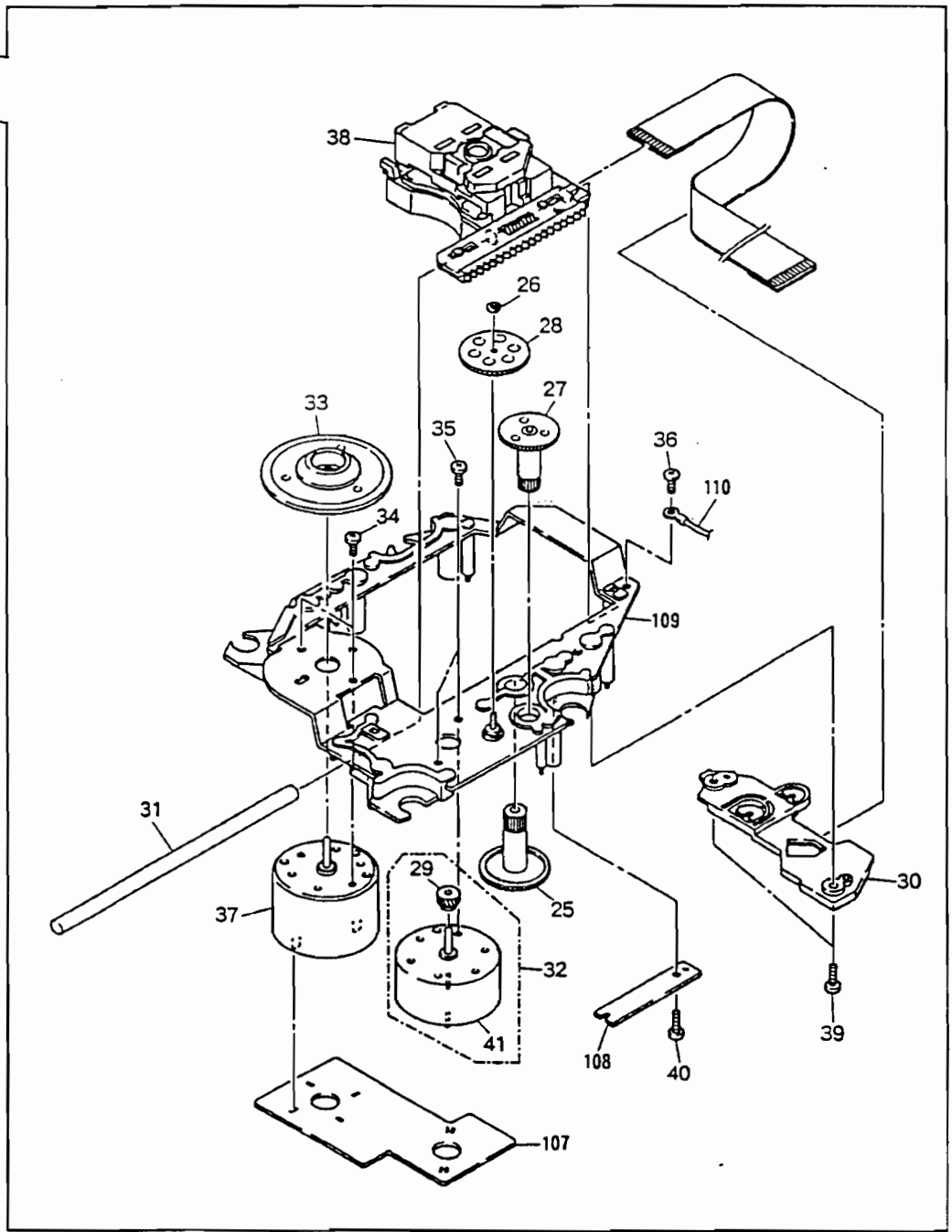

Parts List

Mark	No.	Description	Part No.	Mark	No.	Description	Part No.
	1	Clamp spring	PBH1103	49	Screw	IBZ30P100FMC	
	2	Lever spring	PBH1104	50	Screw	IBZ30P050FZK	
	3	Belt	PEB1106				
	4	Motor pulley	PNW1634				
	5	Tray 1	PNW1839				
	6	Tray 2	PNW1840				
	7	Sub tray	PNW1841	NSP 101	Yoke	PNB1216	
	8	Loading base	PNW1842	NSP 102	Clamp magnet	PMF1014	
	9	Main cam	PNW1843	NSP 103	Clamper holder	PNW1849	
	10	Follow gear	PNW1844	NSP 104	Clamper S	PNW1609	
	11	Gear 1	PNW1845	NSP 105	Mechanism PCB assembly	PWX1162	
	12	Gear 2	PNW1846	NSP 106	Servo mechanism assembly	PXA1478	
	13	Idler gear	PNW1847	NSP 107	Mechanism board assembly	PWX1192	
	14	Clamper arm U	PNW1850	NSP 108	Gear stopper	PNB1303	
	15	Clamper arm B	PNW1851	NSP 109	Carriage base	PNW2058	
	16	Clamp cam	PNW1852	NSP 110	Earth lead unit	XDF-502	
	17	Float base	PNW2041	NSP 111	H spacer	PEB1249	
	18	Lock lever	PNW1854	NSP 112	Sub plate	PNB1287	
	19	D.C. motor(LOADING)	PXM1010	NSP 113	Earth lead unit	PDF1104	
	20	Floating rubber	PEB1014				
	21	Floating rubber	PEB1132				
	22	Screw	PBA1048				
	23	Screw	IPZ30P080FMC				
	24	Screw	IPZ20P080FMC				
	25	Gear 1	PNW2052				
	26	Washer	WT12D032D025				
	27	Gear 2	PNW2053				
	28	Gear 3	PNW2054				
	29	Pinion gear	PNW2055				
	30	PWB holder	PNW2057				
	31	Guide bar	PLA1094				
	32	D.C. motor assembly (CARRIAGE)	PEA1246				
	33	Disc holder	PNW1608				
	34	Screw	JFZ20P030FNI				
	35	Screw	JFZ17P025FZK				
	36	Screw	BBZ26P060FMC				
	37	D.C. motor assembly (with oil)(SPINDLE)	PEA1235				
	38	Pickup assembly	PEA1179				
	39	Screw	BPZ26P100FMC				
	40	Screw	BBZ20P060FMC				
	41	D.C. motor(CARRIAGE)	PXM1027				
	42					
	43					
	44	Screw	PMZ26P040FMC				
	45	Gear pulley	PNW1848				
	46	Push spring	PBH1105				
	47	Screw	IPZ30P200FMC				
	48					

• How to install the disc table

① Use nipper or other tool to cut the three sections marked (A) figure ①. Then remove the spacer.

② While supporting the spindle motor shaft with the stopper, put spacer on top of the motor base (angled so it doesn't touch section (B)), and stick the disc table on top (takes about 9Kg pressure). Take off the spacer.

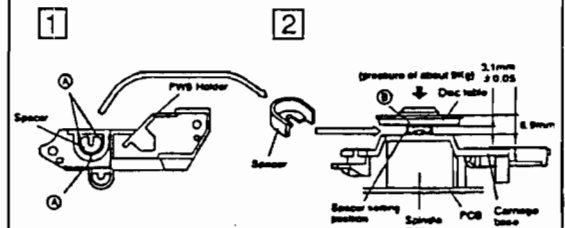

4. SCHEMATIC AND PCB CONNECTION DIAGRAMS

● SCHEMATIC DIAGRAM

Note: (Type 4)

1. When ordering service parts, be sure to refer to "PARTS LIST of EXPLODED VIEWS" or "PCB PARTS LIST".

2. Since these are basic circuits, some parts of them or the values of some components may be changed for improvement.

3. RESISTORS:

Unit: k Ω , M Ω , or Ω unless otherwise noted.

Rated power: 1/4W, 1/8W, 1/8W, 1/10W unless otherwise noted.

Tolerance: (F): $\pm 1\%$, (G): $\pm 2\%$, (K): $\pm 10\%$, (M): $\pm 20\%$ or $\pm 5\%$ unless otherwise noted.

4. CAPACITORS:

Unit: pF or μF unless otherwise noted.

Ratings: capacitor (μF) / voltage (V) unless otherwise noted.

Rated voltage: 50V except for electrolytic capacitors.

5. COILS:

Unit: mH or μH unless otherwise noted.

6. VOLTAGE AND CURRENT:

\square : DC voltage (V) in PLAY mode unless otherwise noted.

\rightarrow mA or \leftarrow mA: DC current in PLAY mode unless otherwise noted.

Value in () is DC current in STOP mode.

7. OTHERS:

● \rightarrow : Signal route.

● \odot : Adjusting point.

● ∇ (Red): Measurement point.

● The Δ mark found on some component parts indicates the importance of the safety factor of the parts. Therefore, when replacing, be sure to use parts of identical designation.

8. SWITCHES (Underline indicates switch position):

MECHANISM BOARD ASSEMBLY

S610 :INSIDE

MECHANISM PCB ASSEMBLY

S601 :U

S602 :S

S603 :L

CONT UNIT

S1001 :DOLBY NR

S1002 :▶

S1003 :◀

S1004 :■

S1005 :▶▶

S1006 :◀◀

S1007 :ASES

S1008 :▶

S1009 :◀

S1010 :■

S1011 :▶▶

S1012 :◀◀

S1013 :● II

S1014 :COPY

S1101 :▶/II

S1102 :▶▶-▶▶

S1103 :PGM

S1104 :AUTO EJECT

S1105 :■

S1106 :◀◀-◀◀

S1108 :RANDOM

S1110 :OPEN/CLOSE II

S1120 :DISC CHANGE

S1121 :REPEAT

S1122 :COMPU PGM

S1124 :OPEN/CLOSE I

4.1 SCHEMATIC DIAGRAM

A
B
C
D
E
F
G

- : PB
- : REC
- (L) : LOADING SERVO LOOP
- (T) : TRACKING SERVO LOOP
- (F) : FOCUS SERVO LOOP
- (S) : SPINDLE SERVO LOOP
- (C) : CARRIAGE SERVO LOOP
- ▶ : MEASUREMENT POINT

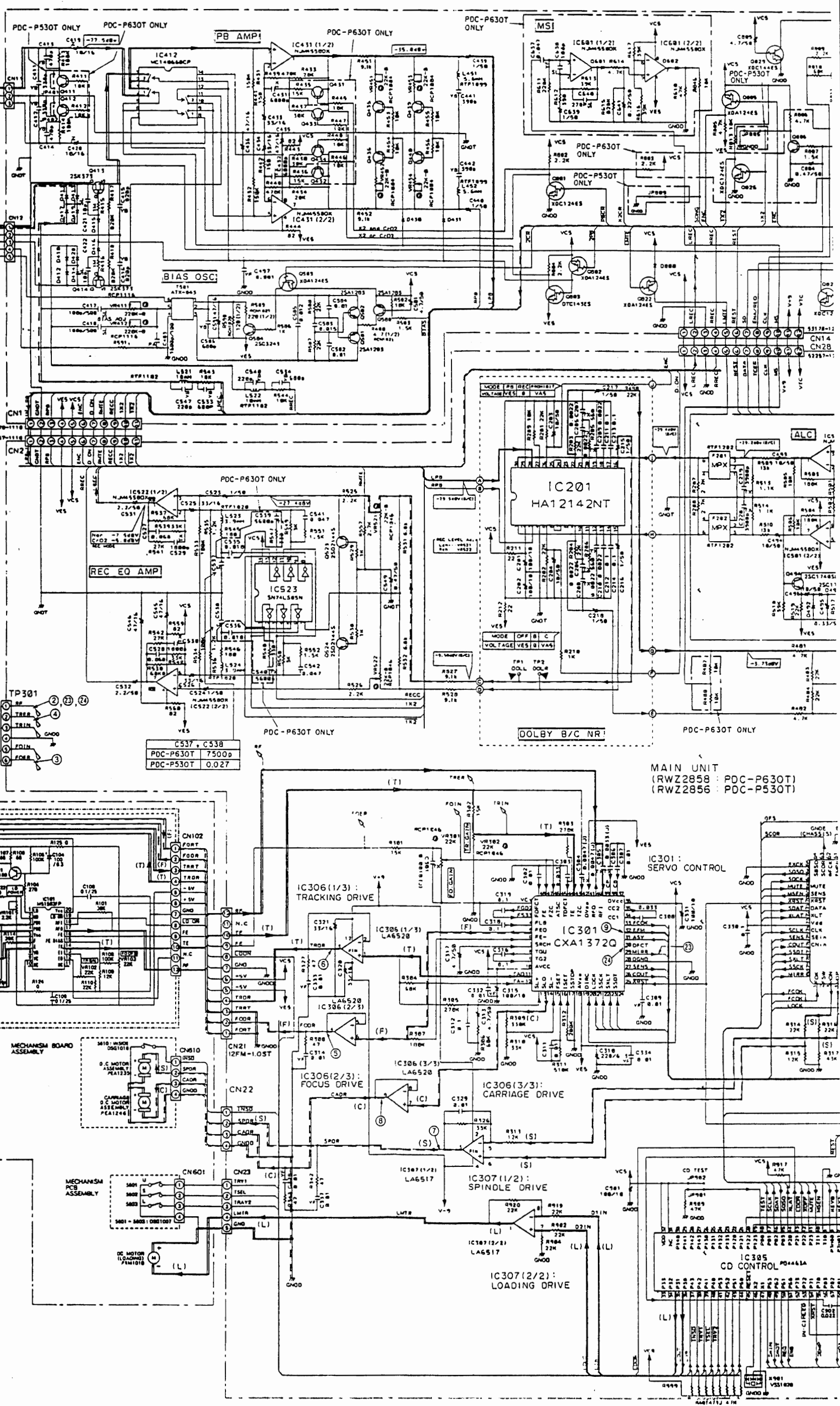

C537, C538	PDC-P630T	7500p
	PDC-P530T	0.027

MAIN UNIT
(RWZ2858 : PDC-P630T)
(RWZ2856 : PDC-P530T)

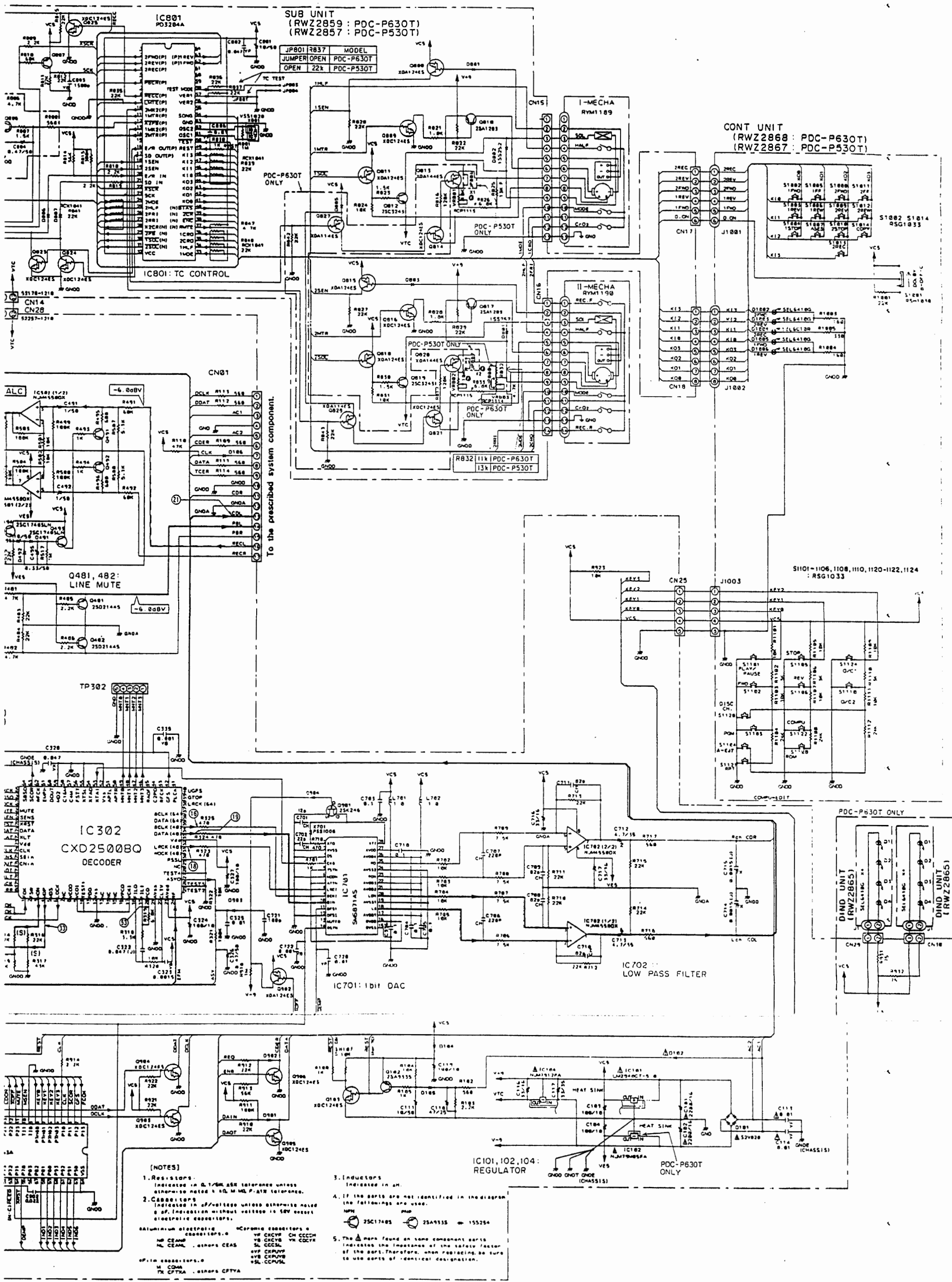

SUB UNIT
(RWZ2859 : PDC-P630T)
(RWZ2857 : PDC-P530T)

JP801	R837	MODEL
JUMPER	OPEN	PDC-P630T
OPEN	22k	PDC-P530T

CONT UNIT
(RWZ2868 : PDC-P630T)
(RWZ2867 : PDC-P530T)

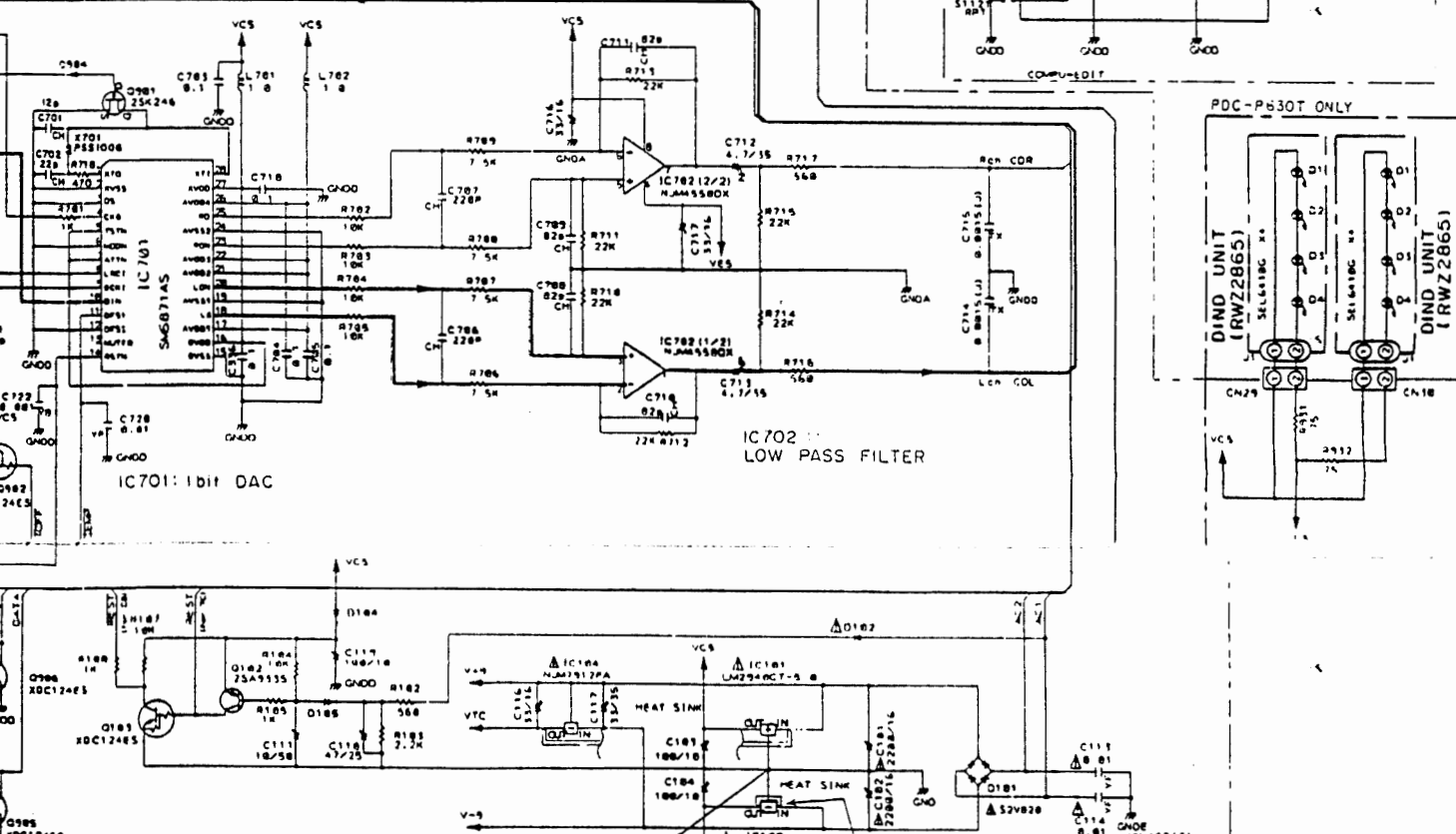
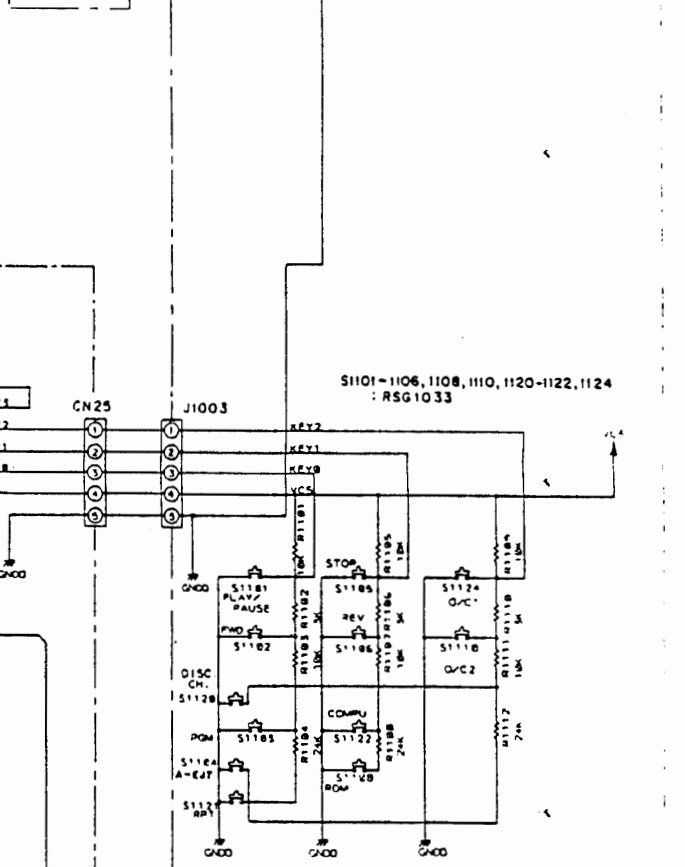
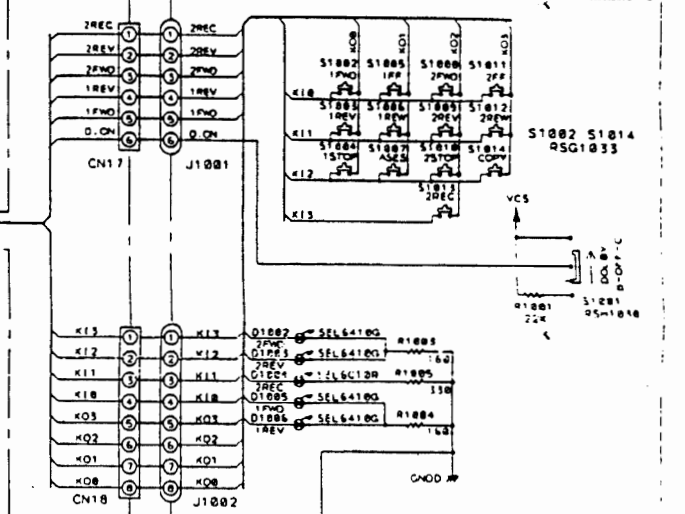
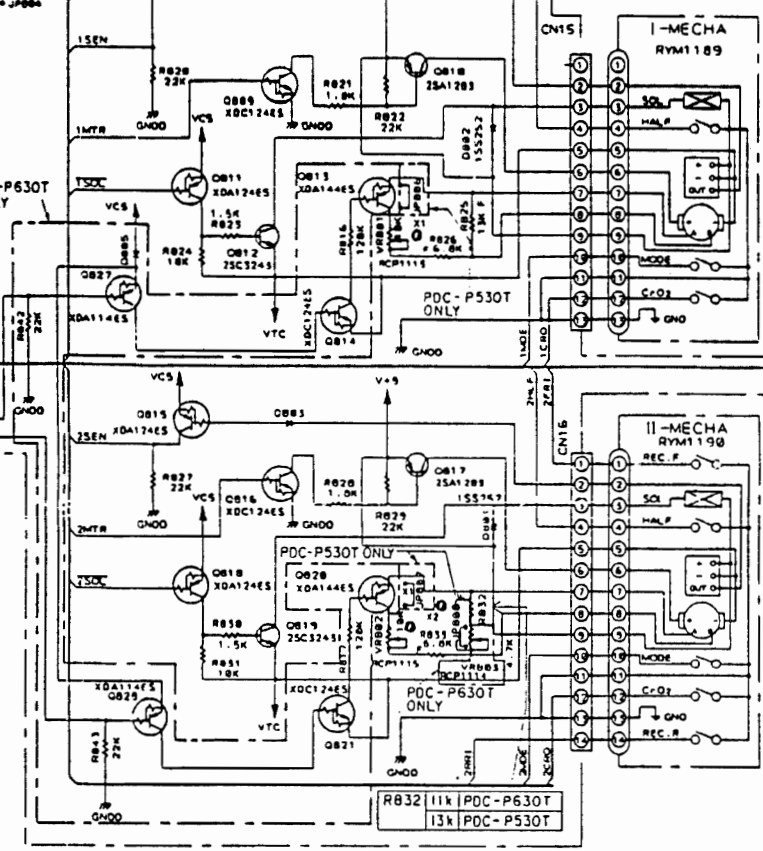
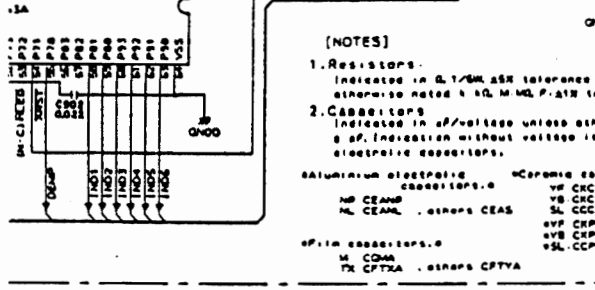
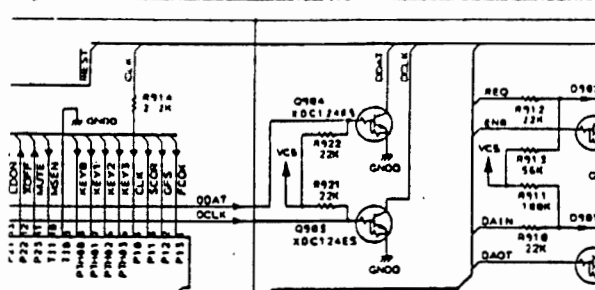
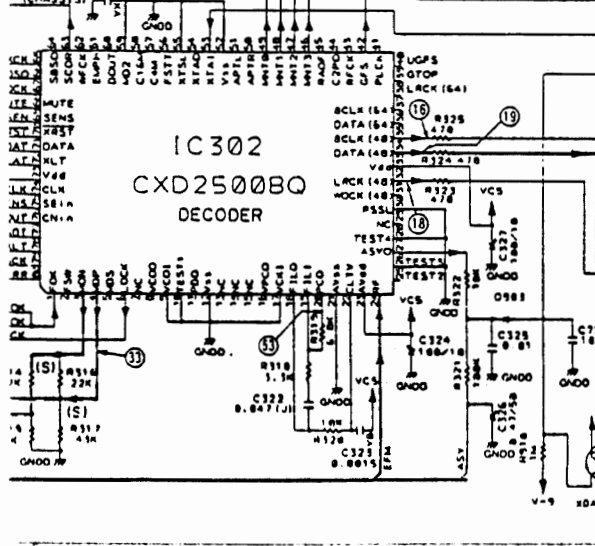
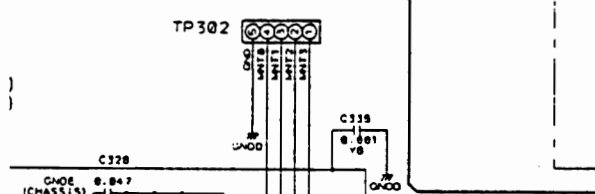
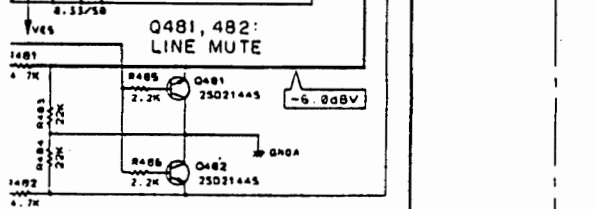
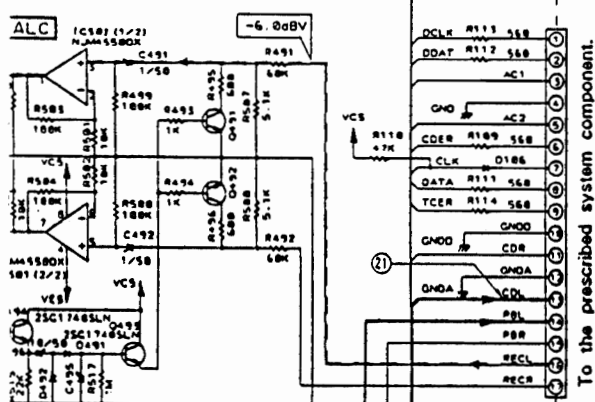

[NOTES]

- Resistors: Indicated in Ω, 1/4W, 5% tolerance unless otherwise noted. 1/2W, 5% tolerance.
- Capacitors: Indicated in μF/voltage unless otherwise noted. 50V. Indication without voltage is 50V except electrolytic capacitors.
- Inductors: Indicated in μH.
- If the parts are not identified in the diagram the following are used: NPN PNP 25C17485 25A9155 155254
- The Δ mark found on some component parts indicates the importance of the tolerance factor of the part. Therefore, when replacing, be sure to use parts of identical designation.

A
B
C
D
E
F

4.2 WAVEFORMS

Note: The encircled numbers denote measuring points in the schematic diagram.

*1 50T-JUMP: After switching to the pause mode, press the manual search key.

*2 FOCUS-IN: Press the key without loading a disc.

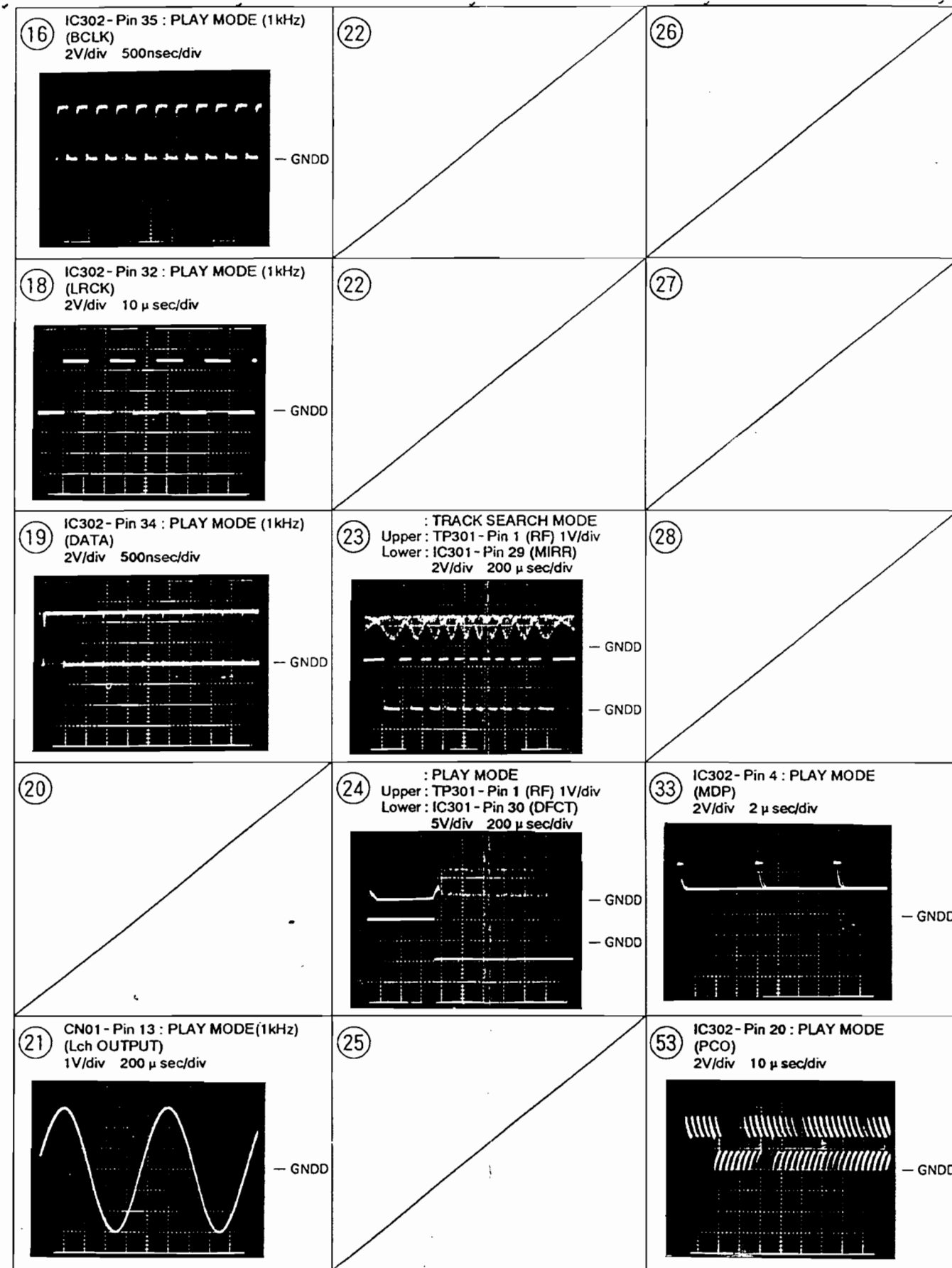
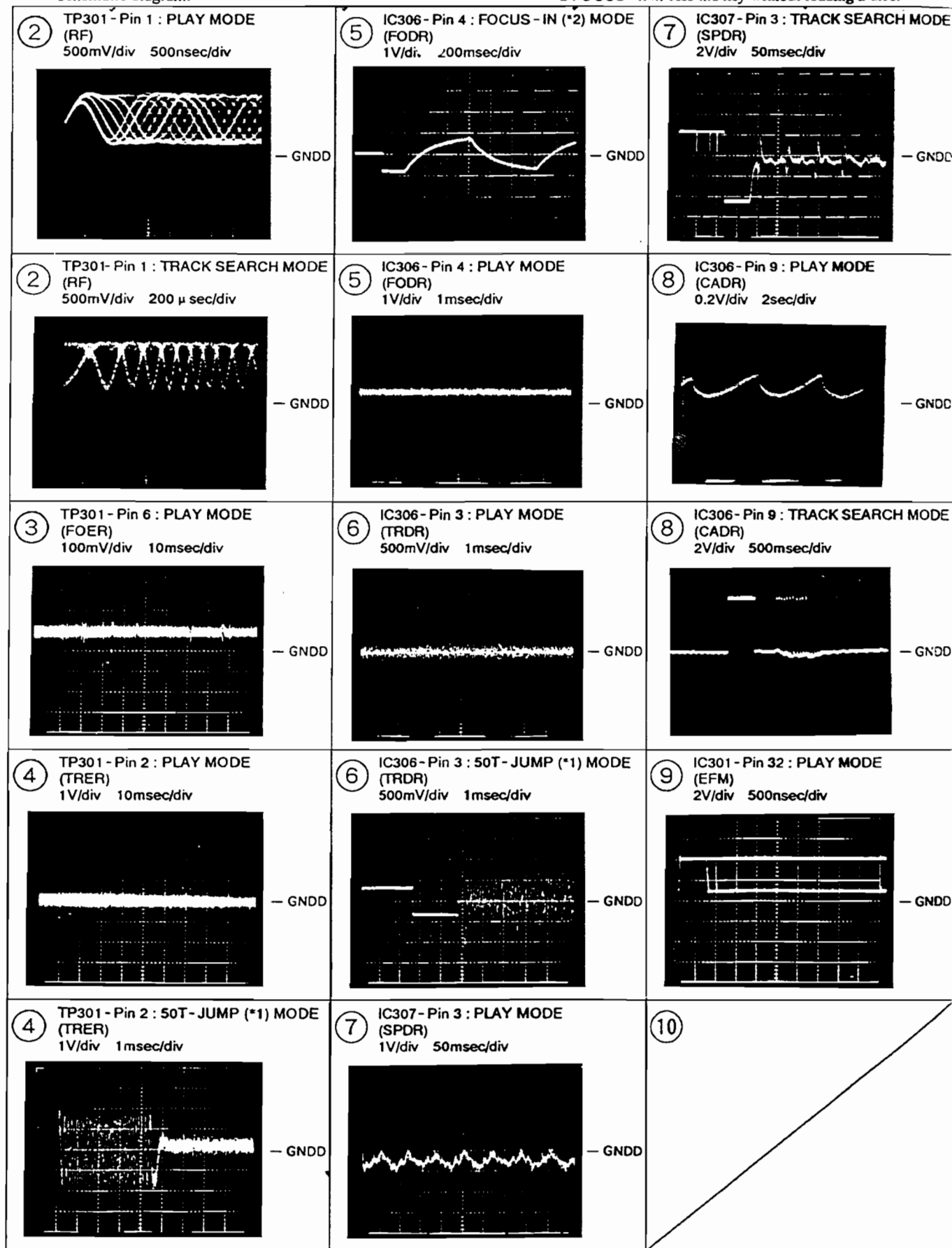

4.3 VOLTAGE TABLE

SUB UNIT

MAIN UNIT

Pin No.	Voltage(V)	Pin No.	Voltage(V)
1	N.C.	33	5
2	4.3	34	5
3	0	35	5
4	0	36	5
5	N.C.	37	2.4
6	4.9	38	0
7	N.C.	39	0
8	0	40	5
9	1.9	41	0
10	2.5	42	0
11	0	43	0
12	4.3	44	0
13	2.5	45	5
14	0	46	5
15	N.C.	47	5
16	0	48	5
17	0	49	0
18	5	50	5
19	5	51	2.2 (CLOCK)
20	5	52	2.1 (CLOCK)
21	4.8	53	0
22	5	54	0
23	0	55	N.C.
24	5	56	0
25	5	57	0
26	5	58	5
27	5	59	N.C.
28	0.1	60	N.C.
29	5	61	N.C.
30	5	62	4.3
31	5	63	0
32	5	64	N.C.

Pin No.	Voltage (V)	Pin No.	Voltage (V)
1	0	25	4.9
2	0	26	0.05
3	0	27	0.05
4	0	28	0
5	0	29	0
6	0	30	N.C.
7	0.3	31	2.5
8	0	32	2.5
9	0	33	0.1
10	5	34	1.3
11	0	35	-1
12	0	36	5
13	0	37	0
14	0	38	-3.5
15	0	39	0
16	-4	40	0
17	1.3	41	-4.9
18	0	42	0
19	-4.9	43	0
20	5	44	0
21	0	45	0
22	5	46	0
23	5	47	0
24	0	48	0

Pin No.	Voltage(V)	Pin No.	Voltage(V)
1	0.1	33	N.C.
2	0	34	N.C.
3	0	35	N.C.
4	5	36	N.C.
5	5	37	0
6	5	38	5
7	5	39	0
8	5	40	0
9	0	41	N.C.
10	0	42	N.C.
11	5	43	N.C.
12	5	44	N.C.
13	5	45	5
14	5	46	2.7 (CLOCK)
15	0	47	2.5 (CLOCK)
16	0 (PULSE)	48	5
17	5	49	0
18	0	50	5
19	0 (PULSE)	51	0
20	2.7 (PULSE)	52	N.C.
21	N.C.	53	N.C.
22	N.C.	54	0
23	N.C.	55	5
24	N.C.	56	N.C.
25	N.C.	57	N.C.
26	N.C.	58	N.C.
27	N.C.	59	N.C.
28	N.C.	60	N.C.
29	N.C.	61	N.C.
30	N.C.	62	N.C.
31	5	63	N.C.
32	5	64	0

Pin No.	Voltage(V)
1	0
2	0
3	0
4	0
5	0
6	0
7	0
8	0
9	0
10	0
11	0
12	11.2
13	-11.9

Pin No.	Voltage(V)
1	0
2	11.2
3	0
4	-11.9
5	0
6	0
7	0
8	0

Pin No.	Voltage(V)	Pin No.	Voltage(V)
1	0.1	41	N.C.
2	N.C.	42	0
3	0	43	N.C.
4	0	44	N.C.
5	N.C.	45	N.C.
6	0	46	4.4
7	N.C.	47	3.3
8	N.C.	48	3.3
9	0	49	0
10	0	50	N.C.
11	N.C.	51	N.C.
12	0	52	0
13	N.C.	53	2.5
14	N.C.	54	N.C.
15	N.C.	55	0
16	N.C.	56	N.C.
17	0	57	N.C.
18	3.2	58	N.C.
19	2.4	59	0
20	2.4	60	N.C.
21	0	61	N.C.
22	3.2	62	N.C.
23	5	63	0
24	2.5	64	N.C.
25	N.C.	65	0
26	0	66	0
27	2.5	67	5
28	0	68	5
29	N.C.	69	0
30	0	70	4.9
31	N.C.	71	0
32	2.5	72	5
33	5	73	5
34	0	74	5
35	2.2	75	0.05
36	N.C.	76	0.05
37	N.C.	77	0
38	N.C.	78	5
39	N.C.	79	5
40	N.C.	80	0

Pin No.	Voltage(V)	Pin No.	Voltage(V)
1	2.9 (CLOCK)	15	0
2	0	16	5
3	0	17	5
4	2.6 (PULSE)	18	2.5 (PULSE)
5	5	19	0
6	0	20	2.5 (PULSE)
7	5	21	5
8	2.4 (PULSE)	22	5
9	2.4 (PULSE)	23	2.5 (PULSE)
10	0	24	0
11	5	25	2.5 (PULSE)
12	0	26	5
13	N.C.	27	5
14	4.9	28	2.5 (CLOCK)

Pin No.	Voltage(V)	Pin No.	Voltage(V)	
1	0	16	0	
2	4.8	17	-2	
3	0	18	OFF -0.5	
4	0	B	-1.8	
5	OFF -3.5	C	-2	
	B	0	19	0
	C	4.6	20	0
6	0	21	0	
7	0	22	0	
8	0	23	0	
9	0	24	0	
10	0	25	0	
11	0	26	-0.3	
12	0	27	-4.4	
13	OFF -0.4	28	0	
	B	-1.8	29	-4.6
	C	-2	30	0
14	-2			
15	0			

Point	Signal name	Mode	Voltage (V)
Ⓐ	×2 and CrO ₂ *	STOP	0
		×2, 1CrO ₂	4
Ⓑ	×2 or CrO ₂	STOP	0
		1-CrO ₂	4
		2-CrO ₂	4
		1-Nor	0
		2-Nor	0
		×1COPY	0
Ⓒ	2PB	×2COPY *	3.5
		1PB	2.5
		2PB	-5
		×1COPY	2
Ⓓ	×2PB *	1PB	3
		×1COPY	3
		×2COPY *	0
Ⓔ	2PB	1PB	-5
		2PB	5
		×2COPY *	-5
		×1COPY	-5
ⓐ	RMUTE	STOP etc.	2.4
		R/P	0
ⓑ	2CR	CR	5
		Nor	0
Ⓒ	1×2 *	Double speed	4.2
		Normal speed	0
Ⓓ	1×2 *	Double speed	0
		Normal speed	5
Ⓕ	Dolby	OFF	-4
		B	0
		C	4.5
Ⓖ	ENCODE	STOP	-0.5
		REC	-0.5
		PB	-4.5

Note : * mark only for the PDC - P630T.

4.4 PCB CONNECTION DIAGRAM

CONT UNIT (RWZ2868 : PDC-P630T)
(RWZ2867 : PDC-P530T)

SUB UNIT (RWZ2859 : PDC-P53C
(RWZ2857 : PDC-P53C)

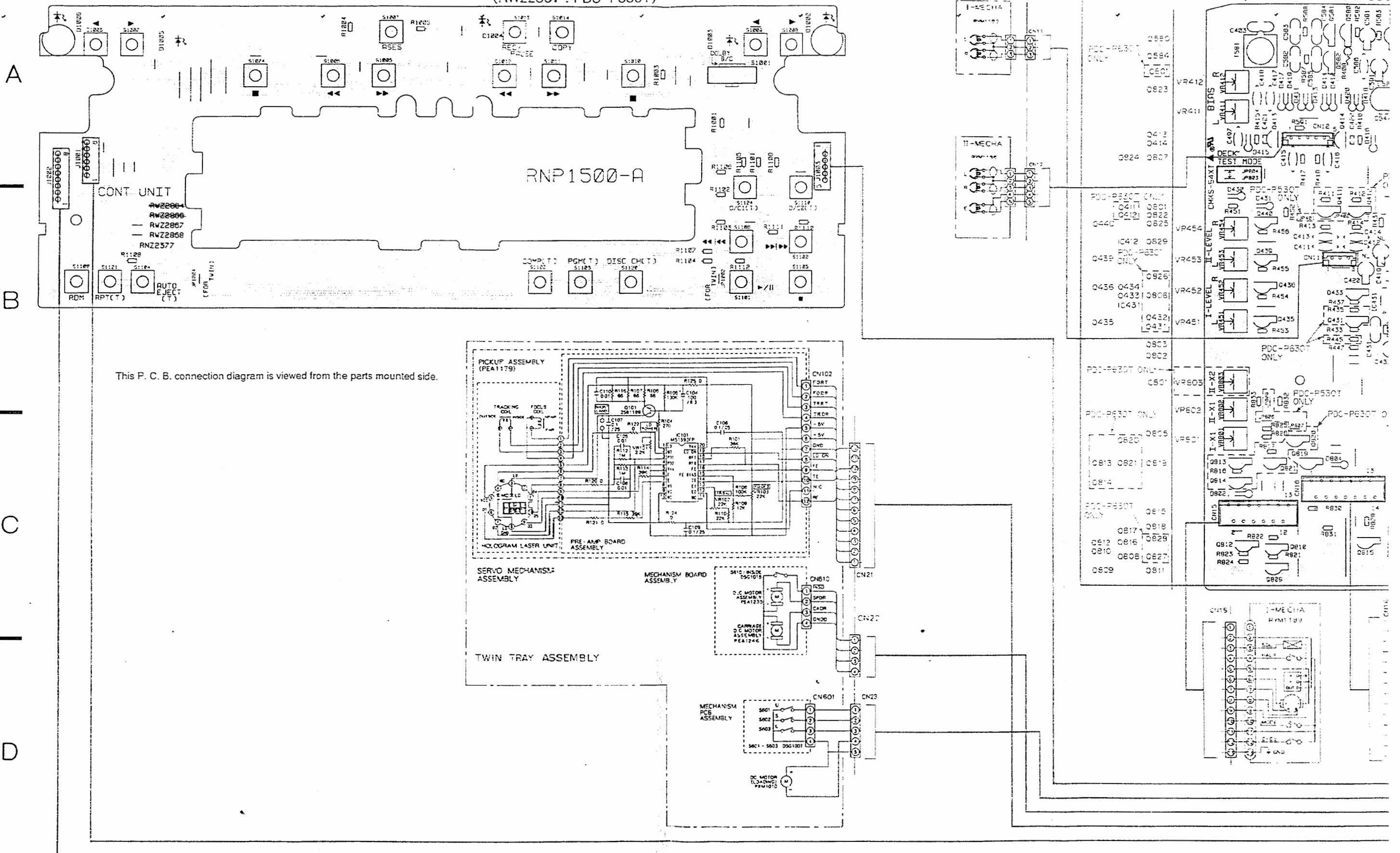

This P. C. B. connection diagram is viewed from the parts mounted side.

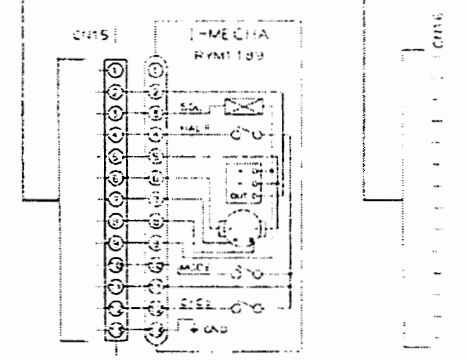
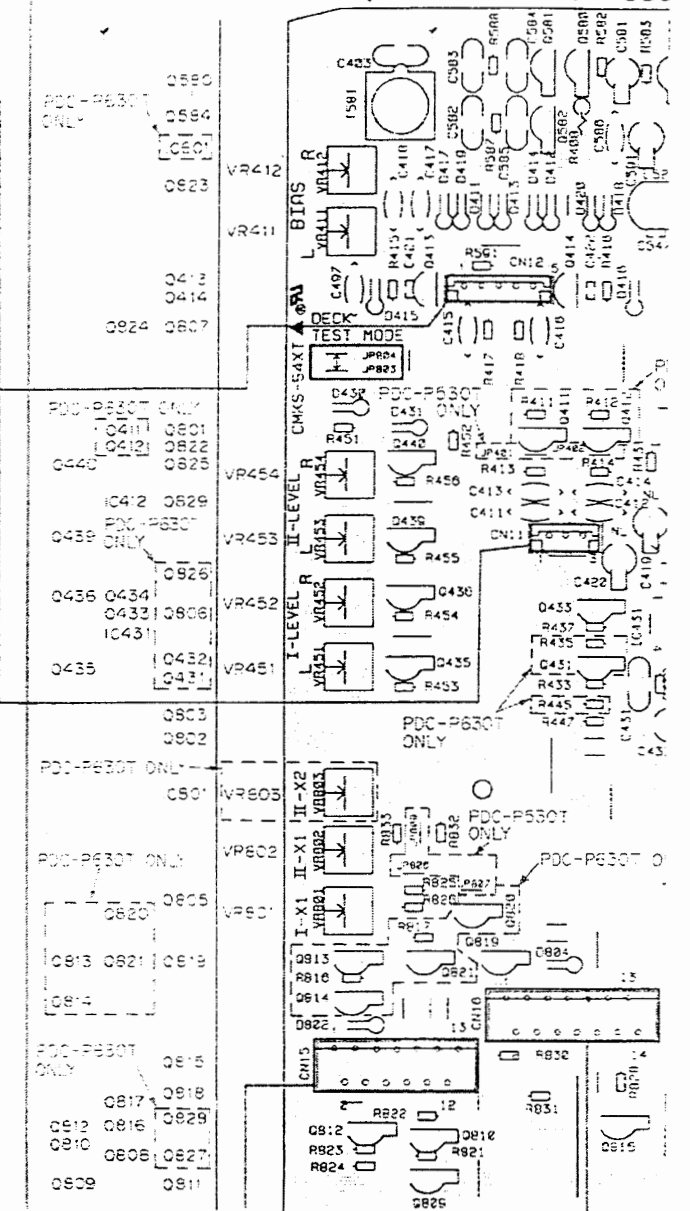
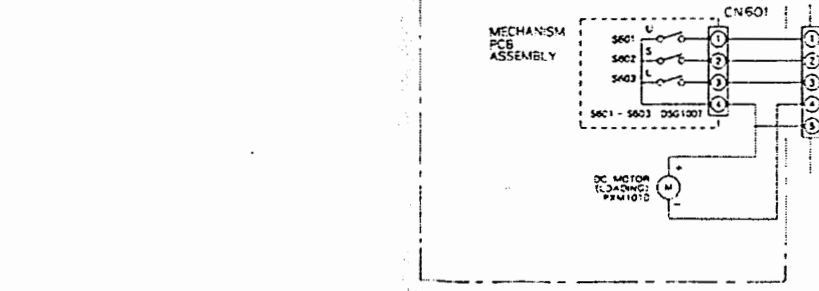
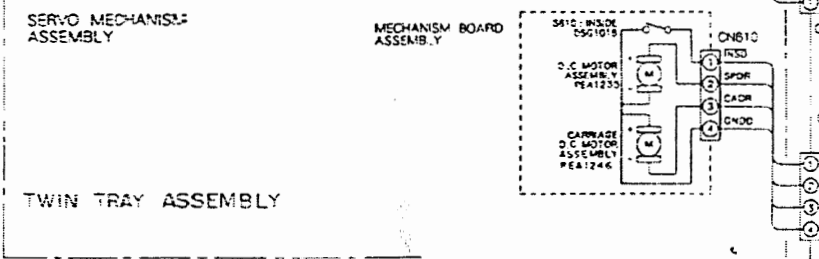
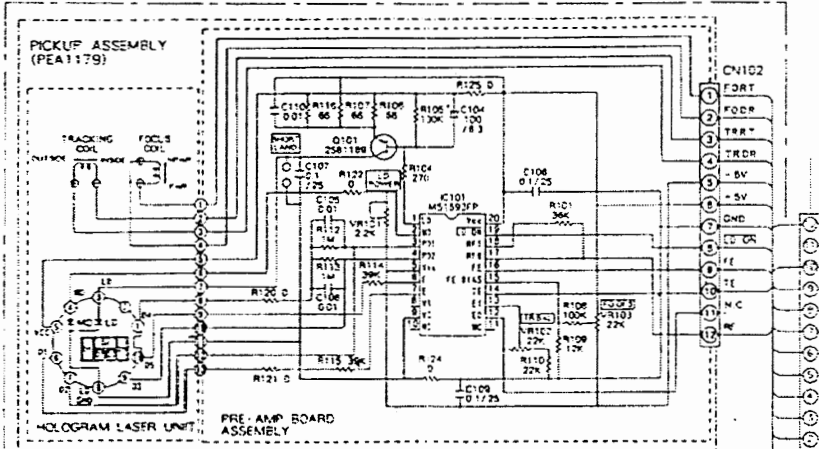

P630T)
P530T)

MAIN UNIT (RWZ2858 : PDC-P630T)
(RWZ2856 : PDC-P530T)

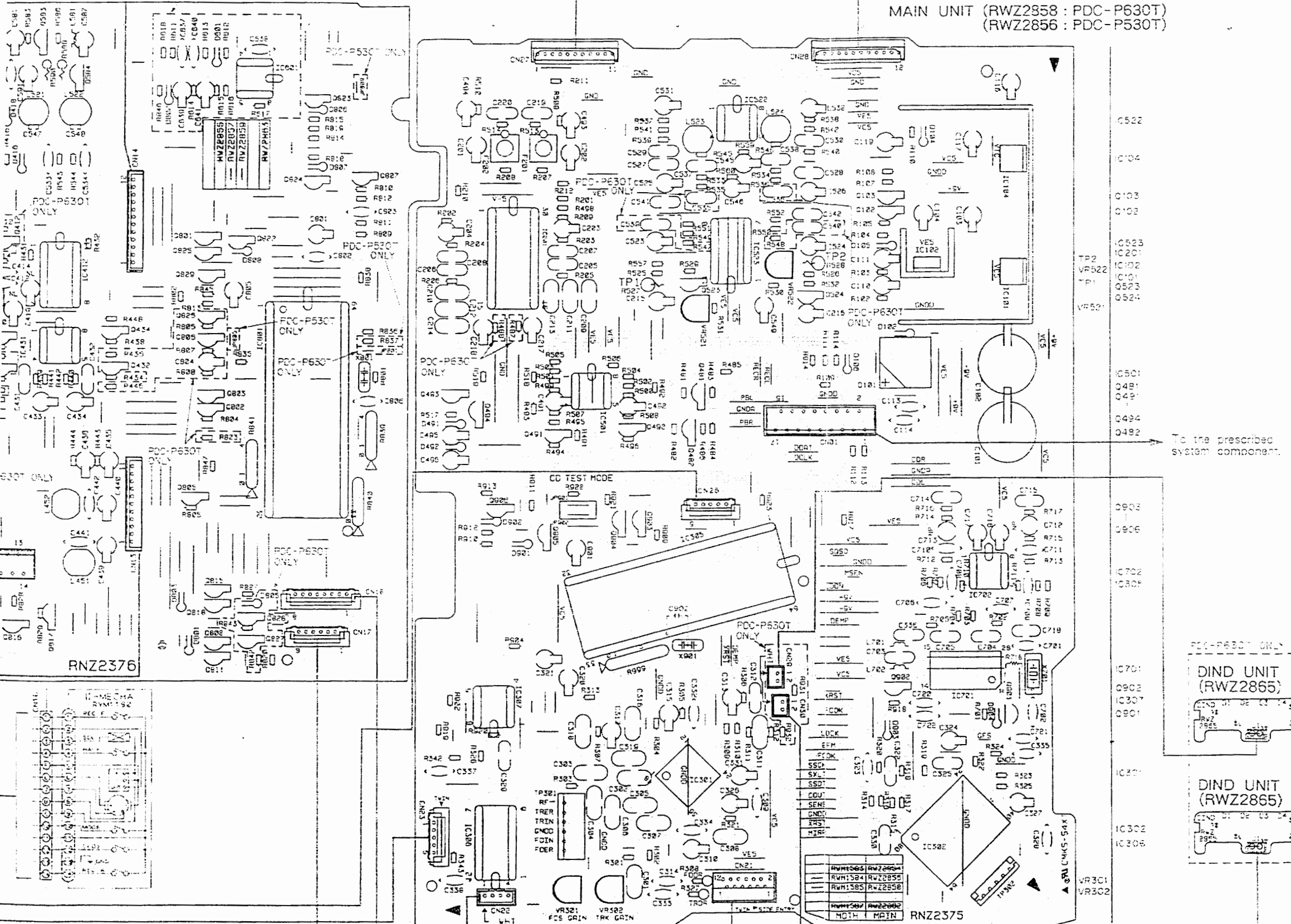

- 0522
- 0104
- 0108
- 0109
- 0523
- 0524
- 0525
- 0526
- 0527
- 0528
- 0529
- 0530
- 0531
- 0532
- 0533
- 0534
- 0535
- 0536
- 0537
- 0538
- 0539
- 0540
- 0541
- 0542
- 0543
- 0544
- 0545
- 0546
- 0547
- 0548
- 0549
- 0550
- 0551
- 0552
- 0553
- 0554
- 0555
- 0556
- 0557
- 0558
- 0559
- 0560
- 0561
- 0562
- 0563
- 0564
- 0565
- 0566
- 0567
- 0568
- 0569
- 0570
- 0571
- 0572
- 0573
- 0574
- 0575
- 0576
- 0577
- 0578
- 0579
- 0580
- 0581
- 0582
- 0583
- 0584
- 0585
- 0586
- 0587
- 0588
- 0589
- 0590
- 0591
- 0592
- 0593
- 0594
- 0595
- 0596
- 0597
- 0598
- 0599
- 0600
- 0601
- 0602
- 0603
- 0604
- 0605
- 0606
- 0607
- 0608
- 0609
- 0610
- 0611
- 0612
- 0613
- 0614
- 0615
- 0616
- 0617
- 0618
- 0619
- 0620
- 0621
- 0622
- 0623
- 0624
- 0625
- 0626
- 0627
- 0628
- 0629
- 0630
- 0631
- 0632
- 0633
- 0634
- 0635
- 0636
- 0637
- 0638
- 0639
- 0640
- 0641
- 0642
- 0643
- 0644
- 0645
- 0646
- 0647
- 0648
- 0649
- 0650
- 0651
- 0652
- 0653
- 0654
- 0655
- 0656
- 0657
- 0658
- 0659
- 0660
- 0661
- 0662
- 0663
- 0664
- 0665
- 0666
- 0667
- 0668
- 0669
- 0670
- 0671
- 0672
- 0673
- 0674
- 0675
- 0676
- 0677
- 0678
- 0679
- 0680
- 0681
- 0682
- 0683
- 0684
- 0685
- 0686
- 0687
- 0688
- 0689
- 0690
- 0691
- 0692
- 0693
- 0694
- 0695
- 0696
- 0697
- 0698
- 0699
- 0700

To the prescribed system component.

P.C.B. connection diagram position	Corresponding part symbol	Part name
		Transistor
		FET
		Diode
		Zener diode
		LED
		Varactor
		Tact switch
		Inductor
		Coil
		Transformer
		Filter
		Ceramic capacitor
		Mylar capacitor
		Styrol capacitor
		Electrolytic capacitor (Non polarized)
		Electrolytic capacitor (Noiseless)
		Electrolytic capacitor (Polarized)
		Electrolytic capacitor (Polarized)
		Power capacitor
		Semi-fixed resistor
		Resistor array
		Resistor
		Resonator
		Thermistor

1. This P.C.B. connection diagram is viewed from the parts mounted side.
2. The parts which have been mounted on the board can be replaced with those shown with the corresponding wiring symbols listed in the above Table.
3. The capacitor terminal marked with shows negative terminal.
4. The diode marked with shows cathode side.
5. The transistor terminal marked with shows emitter.

A
B
C
D

RNP1499-A

5. PCB PARTS LIST

NOTES:

- Parts marked by "NSP" are generally unavailable because they are not in our Master Spare Parts List.
 - The Δ mark found on some component parts indicates the importance of the safety factor of the part. Therefore, when replacing, be sure to use parts of identical designation.
 - Parts marked by "⊙" are not always kept in stock. Their delivery time may be longer than usual or they may be unavailable.
 - When ordering resistors, first convert resistance values into code form as shown in the following examples.
- Ex.1 When there are 2 effective digits (any digit apart from 0), such as 560 ohm and 47k ohm (tolerance is shown by J=5%, Δ K=10%).
- 560 Ω \rightarrow 56 \times 10¹ \rightarrow 561 RD1/8PM $\boxed{5}\boxed{6}\boxed{1}\boxed{J}$
 47k Ω \rightarrow 47 \times 10³ \rightarrow 473 RD1/4PS $\boxed{4}\boxed{7}\boxed{3}\boxed{J}$
 0.5 Ω \rightarrow 0R5 RN2H $\boxed{0}\boxed{R}\boxed{5}\boxed{K}$
 1 Ω \rightarrow 010 RS1P $\boxed{0}\boxed{1}\boxed{0}\boxed{K}$
- Ex.2 When there are 3 effective digits (such as in high precision metal film resistors).
- 5.62k Ω \rightarrow 562 \times 10¹ \rightarrow 5621 RN1/4PC $\boxed{5}\boxed{6}\boxed{2}\boxed{1}\boxed{F}$

Mark	No.	Description	Part No.	Mark	No.	Description	Part No.
------	-----	-------------	----------	------	-----	-------------	----------

LIST OF ASSEMBLIES

		MAIN UNIT	RWZ2858
		SUB UNIT	RWZ2859
		DIND UNIT	RWZ2865
		CONT UNIT	RWZ2868
NSP		MECHANISM PCB ASSEMBLY	PWX1162
NSP		MECHANISM BOARD ASSEMBLY	PWX1192

		C702	CCC3220J50
		C708-C711	CCC3820J50
		C721	CCCS101J50
		C712, C713	CEANP4R7M35
		C215-C218, C491, C492, C523, C524	CEAS010M50
		C111, C203, C204, C493, C494, C496	CEAS100M50
		C103, C104, C119, C201, C202, C315, C324, C327, C331, C901	CEAS101M10
		C310	CEAS221M6R3
Δ		C101, C102	CEAS222M16

MAIN UNIT

SEMICONDUCTORS

		IC301	CXA1372Q
		IC302	CXD2500BQ
		IC201	HA12142NT
		IC307	LA6517
		IC306	LA6520
Δ		IC101	LM2940CT-5.0
		IC501, IC522, IC702	NJM4558DX
Δ		IC104	NJM7912FA
Δ		IC102	NJM79N05FA
		IC305	PD4463A
		IC701	SMS871AS
		IC523	SN74LS05N
		Q102	2SA933S
		Q491, Q492	2SC1740S
		Q493, Q494	2SC1740SLN
		Q481, Q482, Q523, Q524	2SD2144S
		Q901	2SK246
		Q902	XDA124ES
		Q103, Q903-Q906	XDC124ES
Δ		D102	1SS254
		D104-D106, D491, D492, D901-D904	1SS254
Δ		D101	S2VB20

		C531, C532	CEASR2M50
		C116, C320, C321, C525, C526, C716, C717	CEAS330M16
		C117	CEAS330M35
		C545, C546	CEAS470M16
		C110	CEAS470M25
		C313, C317	CEAS4R7M50
		C495	CEASR33M50
		C326, C549	CEASR47M50
		C714, C715	CFTA152J50
		C301, C529, C530	CFTA182J50
		C205-C210	CFTA222J50
		C306	CFTA332J50
		C219, C220	CFTA392J50
		C304, C305	CFTA472J50
		C539, C540	CFTA562J50
		C302, C307, C311, C325, C329	CFTA103J50
		C211-C214, C312, C316, C318, C319, C330, C336, C703-C705, C718	CFTA104J50
		C535, C536	CFTA183J50
		C303, C308	CFTA333J50
		C322, C541, C542	CFTA473J50
		C527, C528	CFTA683J50
		C328	CGCT473K25
		C335, C722	CKCT3102K50
		C323	CKCT3152K50
		C309, C314, C332-C334, C337, C338, C720	CKCTF103Z50
Δ		C113, C114	CKCTF103Z50
		C537, C538	CKCT752J50
		C902	CKCT722Z50

COILS AND FILTERS

		L701, L702	LAU010K
		L523, L524 (3.9mH)	RTF1202
		F201, F202	RTF1202

CAPACITORS

		C706, C707	CCCCH221J50
		C701	CCCCH120J50

Mark No.	Description	Part No.
RESISTORS		
VR301, VR302, VR521, VR522	(22kΩ)	RCP1046
R999	(47kΩ)	RA8T473
R527, R528	(9.1kΩ)	RCN1060
OTHER RESISTORS		RD1/6PM□□□J

Mark No.	Description	Part No.
OTHERS		
CN21	CONNECTOR (12P)	12FM-1.0ST
CN27	CONNECTOR	52257-1110
CN28	CONNECTOR	52257-1210
X701	X'TAL RESONATOR (16.9344MHz)	PSS1006
X901	CERAMIC RESONATOR (4.19MHz)	VSS1028

SUB UNIT

Mark No.	Description	Part No.
SEMICONDUCTORS		
IC412		MC14066BCP
IC431, IC601		NJM4558DX
IC801		PD3204A
Q580-Q582, Q810, Q817		2SA1283
Q807		2SA933S
Q411, Q412, Q431-Q436, Q439, Q440, Q806		2SC1740S
Q584, Q812, Q819		2SC3243
Q413, Q414		2SK373
Q803		DTC143ES
Q827, Q828		XDA114ES
Q583, Q802, Q805, Q808, Q811, Q815, Q818, Q822		XDA124ES
Q813, Q820		XDA144ES
Q801, Q809, Q814, Q816, Q821, Q823-Q826		XDC124ES
Q829		XDC144ES
D802, D804		1SS252
D411-D420, D430, D431, D601, D602, D801, D803, D805-D808		1SS254

COILS AND TRANSFORMER

L451, L452	RTF1099
L521, L522	RTF1102
T581	ATX-043

CAPACITORS

C638	CCCSL101J50
C417, C418	CCCSL101K500
C640	CCCSL271J50
C421, C422	CCPUSL100J50
C419, C420	CEANL100M16
C439, C440, C639	CEAS010M50
C801	CEAS100M50
C433, C434	CEAS330M16
C435, C436, C591	CEAS470M16
C581, C805	CEAS4R7M50
C641	CEASR22M50
C804	CEASR47M50
C431, C432	CFTXA682J50
C582, C584	CFTYA103J50
C585	CFTYA123J50
C583	CFTYA153J50
C803	CKCYB152K50

Mark No.	Description	Part No.
C411, C412		CKCYB331K50
C441, C442		CKCYB391K50
C413, C414		CKCYB471K50
C533, C534, C586		CKCYB681K50
C415, C416		CKCYB821K50
C497		CKCYF102Z50
C806		CKCYF103Z50
C637, C802		CKCYF473Z50
C547, C548		CKPUYB221K50
C403		CQPA162J100

RESISTORS

VR451-VR454	(22kΩ)	RCP1084
VR803	(4.7kΩ)	RCP1114
VR801, VR802	(10kΩ)	RCP1115
VR411, VR412	(220Ω)	RCP1116
R590	(120Ω)	RCN1020
R589	(220Ω)	RCN1021
R408	(4.7Ω)	RCN1022
R839-R841	(22Ω)	RCX1041
R832		RN1/6PQ1102F
R825		RN1/6PQ1302F
R826, R833		RN1/6PQ6801F
OTHER RESISTORS		RD1/6PM□□□J

OTHERS

CN13	CONNECTOR	53178-1110
CN14	CONNECTOR	53178-1210
X801	CERAMIC RESONATOR (4.19MHz)	VSS1028

DIND UNIT

SEMICONDUCTORS		
DI -D4		SEL6410G

CONT UNIT

SEMICONDUCTORS		
D1002, D1003, D1005, D1007		SEL6410G
D1004		SEL6C10R

SWITCHES

S1002-S1014, S1101-S1105, S1108, S1110	RSG1033
S1120-S1122, S1124	
S1001	RSH1030

RESISTORS

OTHER RESISTORS	RD1/6PM□□□J
-----------------	-------------

MECHANISM PCB ASSEMBLY

SWITCHES		
S601-S603		DSG1017

MECHANISM BOARD ASSEMBLY

SWITCH		
S610		DSG1016

6. ADJUSTMENTS

6.1 DECK SECTION

Perform these adjustments in test mode.

- To activate the test mode : Turn on power while short-circuiting JP803 and JP804 in the SUB unit. Use the GGF1148 power control jig and the GGF1171 connection adapter for servicing.

6.1.1 Mechanism Section

1. Adjustment and verification of the tape speed						
No.	Deck	Mode	Test tape	Adjustment point	Standard value (playback frequency)	Remarks
1	I	Normal-speed playback	STD-301E (3kHz)	Press the FF (REV) key after playing the tape for 1 minute. *1		
2		Double-speed playback		Verification	6000Hz ± 600Hz (Pins 14 or 15 of CN01)	
3	II	Normal-speed playback		Press the FF (REV) key after verification.		
4		Double-speed playback		Press the FF (REV) key after playing the tape for 1 minute. *1		
5	II	Double-speed playback		VR803	± 10Hz with respect to the value verified in Step 2 (DECK I).	
6		Normal-speed playback		Press the FF (REV) key after verification.		
7	I	Normal-speed playback		VR802	3000Hz ± 5Hz (Pins 14 or 15 of CN01)	
8		Normal-speed playback		VR801	± 5Hz with respect to the value verified in Step 7 (DECK II).	

*1 : The tape runs at the double speed while the FF (REV) key is pressed during playback.
 Note : Perform steps 7 and 8 only for the PDC - P530T.

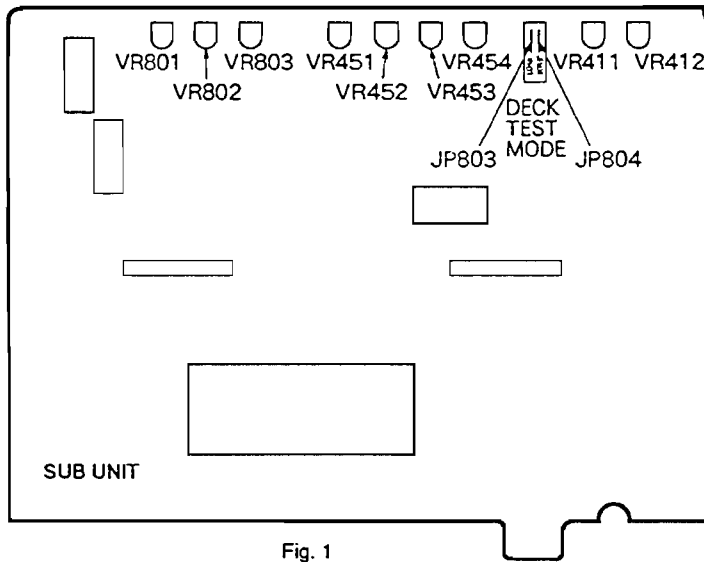

Fig. 1

• Verification and adjustment of the door damper

- Attach the door spring to the position (a) shown in Fig. 2 and stand the front panel assembly vertically as shown in Fig. 3.
- Open the doors of DECK I and DECK II simultaneously. When one of the doors fully opens, check that the difference in position from the other door is within 15 mm.
- If the requirement mentioned in Step 2 is not satisfied, change and adjust the attaching position of the door spring as follows.
 - If the door of DECK I opens more slowly than that of DECK II :
Change the position of the door spring for DECK I to (b).
 - If the door of DECK I opens faster than that of DECK II :
Change the position of the door spring for DECK II to (b).

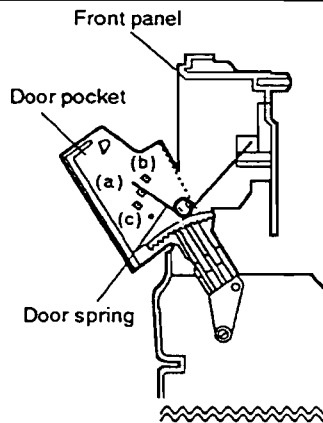

Fig. 2

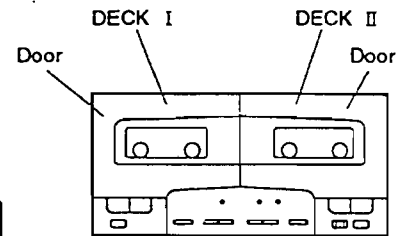

Fig. 3

6.1.2 Electrical Adjustment

Requirements for adjustments

1. Mechanical adjustments have been completed.
2. The heads have been cleaned and demagnetized.
3. Wait for a few minutes before making the adjustments.
4. The signal level must be 0 dBV = 1 Vrms.
5. Connect a load resistance of 50k ohms (47 to 52k ohms accepted) to the line output connectors. (*1)
6. Set the DOLBY NR switch to OFF unless otherwise specified

Test tapes

For adjustments of the playback system:

STD-331E (Fig. 4)

NORMAL blank tape: STD-631

CrO₂ blank tape: STD-621

Note: The reference recording level of the STD-331E is 250 nwb/m, which is 4 dB higher than that of STD-331B (160 nwb/m) in recording. Be sure to check the tape type before adjustment.

• Playback system

1. Head angle adjustment
2. Playback level adjustment

• Recording system

1. Recording bias adjustment
2. Recording level adjustment

The automatic tape selector mechanism is incorporated.

Dolby noise reduction manufactured under license from Dolby Laboratories Licensing Corporation.
"DOLBY" and the double-D system  are trademarks of Dolby Laboratories Licensing Corporation.

- Note *1:
- Connect about 60k ohms when the GGF1148 jig is used.
 - The load resistance is not necessary when the prescribed system component is connected.

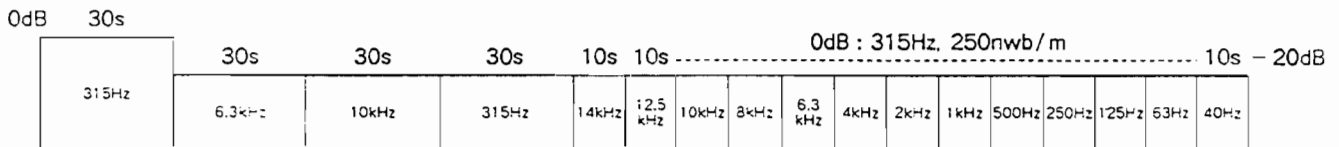

Fig. 4 Test tape STD-331E

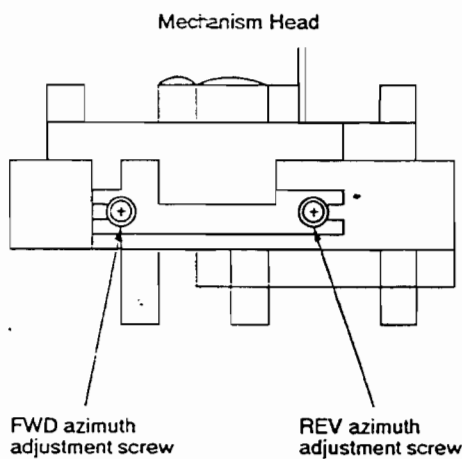

Fig. 5 Head angle adjustment

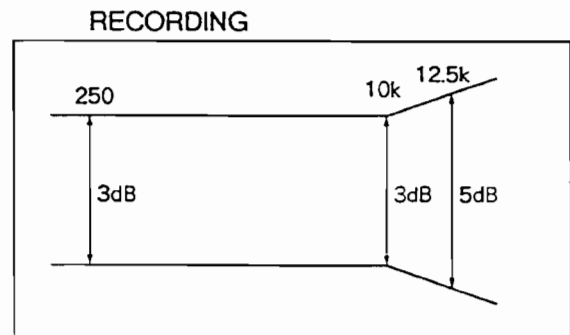
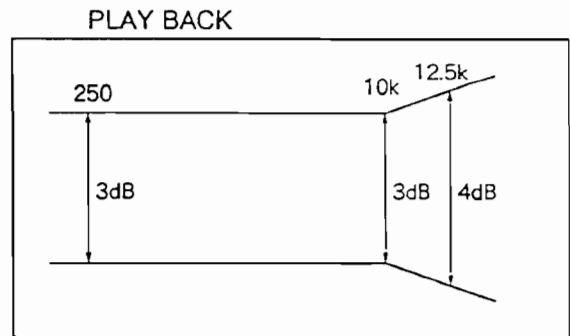

Fig. 6 Frequency response

Playback system

1. Head angle adjustment

No.	Mode	Input signal/test tape	Adjusting point	Measuring point	Adjustment value	Remarks
1	PLAY	Play 10 kHz/- 20 dB of the STD-331E test tape.	Head-azimuth adjustment screw (Fig. 5)	Pins 14 or 15 of CN01	Maximum playback signal level	
2	STOP	When the adjustment is completed, apply adhesive to secure the screws.				

2. Playback level adjustment

No.	Mode	Input signal/test tape	Adjusting point	Measuring point	Adjustment value	Remarks	
1	PLAY	Play 315 Hz/0 dB of the STD-331E test tape.	DECK I	VR451 (L ch)	TP1 (L ch)	- 9.5dBV	This adjustment must be accurate, as it determines the DOLBY level.
				VR452 (R ch)			
			DECK II	VR453 (L ch)	TP2 (R ch)		
				VR454 (R ch)			

Note: TP1 and TP2 are located in the MAIN unit. See Fig. 1 - Adjusting points in "6.2 CD section."

Recording system

1. Recording bias adjustment

No.	Mode	Input signal/test tape	Adjusting point	Measuring point	Adjustment value	Remarks
1	REC/ PAUSE	Apply a signal to the line input from an external oscillator and adjust the oscillator so that the line output is 315 Hz/- 30 dBV. Then load the STD-631 (NORM) tape.	The output level control of the oscillator	Pins 14 or 15 of CN01	—	Line input: CN01 - 16 or 17 pin Line output: CN01 - 15 or 16 pin
2	REC → PLAY	Record the 315 Hz and 6.3 kHz signals at the above-mentioned level and reproduce the recorded signals.	DECK II		VR411 (L ch)	Repeat the recording and playback operations for compensation until the playback level of the 6.3 kHz signal is +0.5 dB ± 0.5 dB with respect to that of the 315 Hz signal.
					VR412 (R ch)	
3	When the adjustment is completed, check the distortion to eliminate underbiasing.					

2. Recording level adjustment

- Set the DOLBY NR switch to ON.

No.	Mode	Input signal/test tape	Adjusting point	Measuring point	Adjustment value	Remarks
1	REC/ PAUSE	Load the STD-631 (NORM) tape and apply a signal to the line input from an external oscillator. Gradually increase the input level so that the line output is 315 Hz/- 13.5 dBV.	The output level control of the oscillator	TP1 (L ch) TP2 (R ch)	—	Line input: CN01 - 16 or 17 pin Line output: CN01 - 15 or 16 pin
2	REC → PLAY	Record the above-mentioned input signal and reproduce the recorded signal.	DECK II		VR521 (L ch)	Repeat the recording and playback operations for compensation until the playback level is - 13.5 dBV.
					VR522 (R ch)	
3	REC → PLAY	Record the above-mentioned input signal on the STD-621 (CrO ₂) tape and reproduce the recorded signal.	Verification		- 13.5dBV ± 1.5dB	

Note: VR521 and VR522 are located in the MAIN unit. See Fig. 1 - Adjusting points in "6.2 CD section."

6.2 CD SECTION

Adjustment Methods

If a disc player is adjusted incorrectly or inadequately, it may malfunction or not work at all even though there is nothing at all wrong with the pickup or the circuitry. Adjust correctly following the adjustment procedure.

● Adjustment Items/Verification Items and Order

If the specified values cannot be obtained or no adjustment is possible by performing the verifications or adjustments described in steps 1 – 4, the pickup block may be defective.

Step	Item	Test Point	Adjustment Location
1	Focus offset verification	TP301, Pin 6(FCS. ERR)	None
2	Tracking error balance verification	TP301, Pin 2(TRK. ERR)	None
3	Pickup radial/tangential direction tilt adjustment	TP301, Pin 1(RF)	Radial tilt adjustment screw, Tangential tilt adjustment screw
4	RF level verification.	TP301, Pin 1(RF)	None
5	Focus servo loop gain adjustment	TP301, Pin 5(FCS. IN) TP301, Pin 6(FCS. ERR)	VR152(FCS. GAN)
6	Tracking servo loop gain adjustment	TP301, Pin 3(TRK. IN) TP301, Pin 2(TRK. ERR)	VR151 (TRK. GAN)

● Abbreviation table

- FCS. ERR :Focus Error
- TRK. ERR :Tracking Error
- FCS GAN :Focus Gain
- TRK GAN :Tracking Gain
- FCS. IN :Focus In
- TRK. IN :Tracking In

● Measuring Instruments and Tools

1. Dual trace oscilloscope (10:1 probe)
2. Low-frequency oscillator
3. Test disc (YEDS-7)
4. 8- cm disc (with about 20 minutes of recording)
5. Low pass filter ($39k\Omega +0.001\mu F$)
6. Resistor (100 k Ω)
7. Ball point hexagon wrench (size:1.5mm) GGK1002
8. Standard tools

● Test Point and Adjustment Variable Resistor Positions

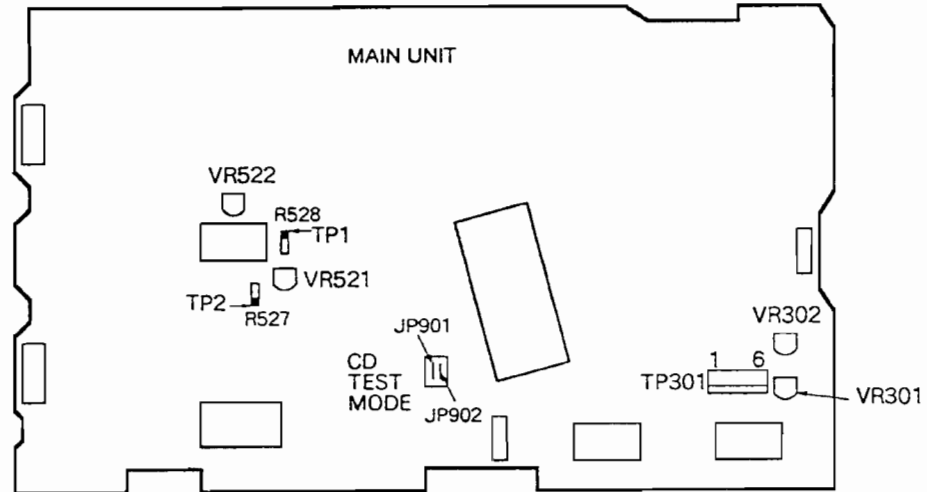

Figure 1. Adjustment Locations

● Notes

1. Use a 10:1 probe for the oscilloscope.
2. All the knob positions (settings) for the oscilloscope in the adjustment procedures are for when a 10:1 probe is used.

● Test Mode

These models have a test mode so that the adjustments and checks required for service can be carried out easily. When these models are in test mode, the keys on the front panel work differently from normal. Adjustments and checks can be carried out by operating these keys with the correct procedure. For these models, all adjustments are carried out in test mode.

[Setting these models to test mode]

How to set this model into test mode.

1. Turn off the power switch.
2. Press the TEST mode switch (JP901 and JP902). (See Figure 1.)
3. Turn on the power switch.

When the test mode is set correctly, the display is different from what it usually is when the power is turned on. If the display is still the same as usual, test mode has not been set correctly, so repeat Steps 1 – 3.





[Release from test mode]

Here is the procedure for releasing the test mode:

1. Press the STOP key and stop all operations.
2. Turn off the power switch on the front panel.

[Operations of the keys in test mode]

Code	Key Name	Function in Test Mode	Explanation
PROGRAM	PROGRAM	Focus servo close	<p>The laser diode is lit up and the focus actuator is lifted up, then lowered slowly and the focus servo is closed at the point where the objective lens is focused on the disc. With the player in this state, if you lightly rotate the stopped disc by hand, you can hear the sound the focus servo.</p> <p>If you can hear this sound, the focus servo is operating correctly. If you press this key with no disc mounted, the laser diode lights up, the focus actuator is pulled up, then the actuator is lowered and raised three times and returned to its original position.</p>
▶/□□	PLAY /BACK	Spindle servo ON	<p>Starts the spindle motor in the clockwise direction and when the disc rotation reaches the prescribed speed (about 500 rpm at the inner periphery), sets the spindle servo in a closed loop.</p> <p>Be careful. Pressing this key when there is no disc mounted makes the spindle motor run at the maximum speed.</p> <p>If the focus servo does not go correctly into a closed loop or the laser light shines on the mirror section at the outermost periphery of the disc, the same symptom is occurred.</p>
		Tracking servo close/open	<p>Pressing this key when the focus servo and spindle servo are operating correctly in closed loops puts the tracking servo into a closed loop, displays the track number being played back and the elapsed time on the front panel, and outputs the playback signal.</p> <p>If the elapsed time is not displayed or not counted correctly or the audio is not played back correctly, it may be that the laser is shining on the section with no sound recorded at the outer edge of the disc, that something is out of adjustment, or that there is some other problem.</p> <p>This key is a toggle key and open/close the tracking servo alternately. This key has no effect if no disc is mounted.</p>

Code	Key Name	Function in Test Mode	Explanation
 (◀◀)	MANUAL SEARCH REV	Carriage reverse (inwards)	Moves the pickup position toward the inner diameter of the disc. When this key is pressed with the tracking servo in a closed loop, the tracking servo automatically goes into an open loop. Since the motor does not automatically stop at the mechanical end point in test mode, be careful with this operation.
 (▶▶)	MANUAL SEARCH FWD	Carriage forward (outwards)	Moves the pickup position toward the outer diameter of the disc. When this key is pressed with the tracking servo in a closed loop, the tracking servo automatically goes into an open loop. Since the motor does not automatically stop at the mechanical end point in test mode, be careful with this operation.
	STOP	Stop	Initializes and the disc rotation stops. The pickup and disc remain where they are when this key is pressed.
	OPEN /CLOSE DISC 1	Disc tray open/close	Open/close the disc tray. This key is a toggle key and open/close tray alternately.
REPEAT	REPEAT	Carriage movement (to the middle of the disc)	The carriage moves to the middle (R=35 mm) of a 12-cm disc. When this key is pressed in focus-in and spindle-servo ON status, the carriage returns to the inner periphery and subsequently moves to the middle of a 12-cm disc.

[How to play back a disc in test mode]

In test mode, since the servos operate independently, playing back a disc requires that you operate the keys in the correct order to close the servos.

Here is the key operation sequence for playing back a disc in test mode.

- PGM(PROGRAM) Lights up the laser diode and closes the focus servo.
↓
- PLAY/PAUSE ▷/▢ Starts the spindle motor and closes the spindle servo.
↓
- PLAY/PAUSE ▷/▢ Closes the tracking servo.

Wait at least 2-3 seconds between each of these operations.

Note : After the tracking servo is once closed, it opens and closes repeatedly each time the ▷/▢ keys are pressed.

1. Focus Offset Verification

● Objective	Verify the DC offset for the focus error amp.		
● Symptom when out of adjustment	The model does not focus in and the RF signal is dirty.		
● Measurement instrument connections	Connect the oscilloscope to TP301, Pin 6 (FCS. ERR)	● Player state	Test mode, stopped (just the Power switch on)
	[Settings] 5 mV/division 10 ms/division DC mode	● Adjustment location	None
		● Disc	None needed
[Procedure]			
Verify the DC voltage at TP301, Pin 6 (FCS. ERR) is 0 ± 50 mV.			

Note : If the specified values cannot be obtained or no adjustment is possible by performing the verifications or adjustments described in adjustment items 1 – 4, the pickup block may be defective.

2. Tracking Error Balance Verification

● Objective	To verify that there is no variation in the sensitivity of the tracking photo diode.		
● Symptom when out of adjustment	Play does not start or track search is impossible.		
● Measurement instrument connections	Connect the oscilloscope to TP301, Pin 2 (TRK. ERR). This connection may be via a low pass filter.	● Player state	Test mode, focus and spindle servos closed and tracking servo open
	[Settings] 50 mV/division 5 ms/division DC mode	● Adjustment location	None
		● Disc	YEDS-7
[Procedure]			
<ol style="list-style-type: none"> 1. Move the pickup to midway across the disc (R=35 mm) with the FWD >> or REV << key. 2. Press the PGM (PROGRAM) key, then the PLAY/PAUSE > / key in that order to close the focus servo then the spindle servo. 3. Line up the bright line (ground) at the center of the oscilloscope screen and put the oscilloscope into DC mode. 4. Supposing that the positive amplitude of the tracking error signal at TP301, pin 2 (TRK ERR) is (A) and the negative amplitude is (B), the following expression is satisfied. 			
<p>When $A \geq B$, $\frac{A-B}{C} \times \frac{1}{2} \leq 0.1$</p> <p>When $A < B$, $\frac{B-A}{C} \times \frac{1}{2} \leq 0.1$</p>		<p>When there is a DC component</p> <p>When there is no DC component</p>	

3. Pickup Radial/Tangential Tilt Adjustment

<ul style="list-style-type: none"> ● Objective 	To adjust the angle of the pickup relative to the disc so that the laser beams are shone straight down into the disc for the best read out of the RF signals.		
<ul style="list-style-type: none"> ● Symptom when out of adjustment 	Sound broken; some discs can be played but not others.		
<ul style="list-style-type: none"> ● Measurement instrument connections 	Connect the oscilloscope to TP301, Pin 1 (RF). [Settings] 20 mV/division 200 ns/division AC mode	<ul style="list-style-type: none"> ● Player state 	Test mode, play
		<ul style="list-style-type: none"> ● Adjustment location 	Pickup radial tilt adjustment screw and tangential tilt adjustment screw
		<ul style="list-style-type: none"> ● Disc 	8-cm disc (with about 20 minutes of recording)

[Procedure]

1. Press the FWD $\triangleright\triangleright$ or REV $\triangleleft\triangleleft$ key to move the pickup position toward the outer periphery of the disc.
Press the PGM (PROGRAM) key, the PLAY/PAUSE \triangleright / \square key twice in that order to close the respective servos and put the player into play mode.
2. First, adjust the radial tilt adjustment screw with the hexagon wrench G GK1002 so that the eye pattern (the diamond shape at the center of the RF signal) can be seen the most clearly.
3. Next, adjust the tangential tilt adjustment screw with the hexagon wrench G GK1002 so that the eye pattern (the diamond shape at the center of the RF signal) can be seen the most clearly (Figure 3).
Note: A standard hexagon wrench can not be used as the disc hinders adjustment.
4. Adjust the radial tilt adjustment screw and the tangential tilt adjustment screw again so that the eye pattern can be seen the most clearly. As necessary, adjust the two screws alternately so that the eye pattern can be seen the most clearly.
5. When the adjustment is completed, lock the radial and tangential adjustment screw.
Note: Radial and tangential mean the directions relative to the disc shown in Figure 2.

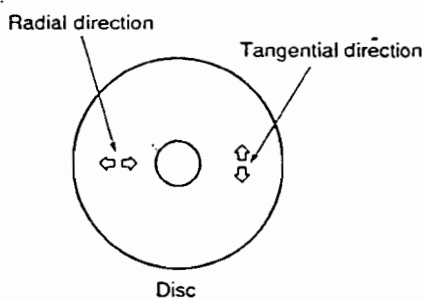
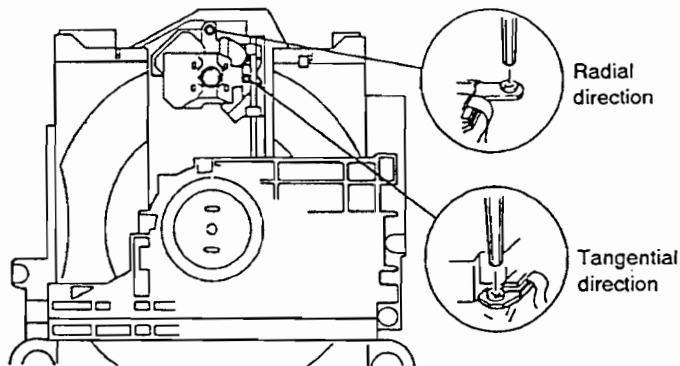
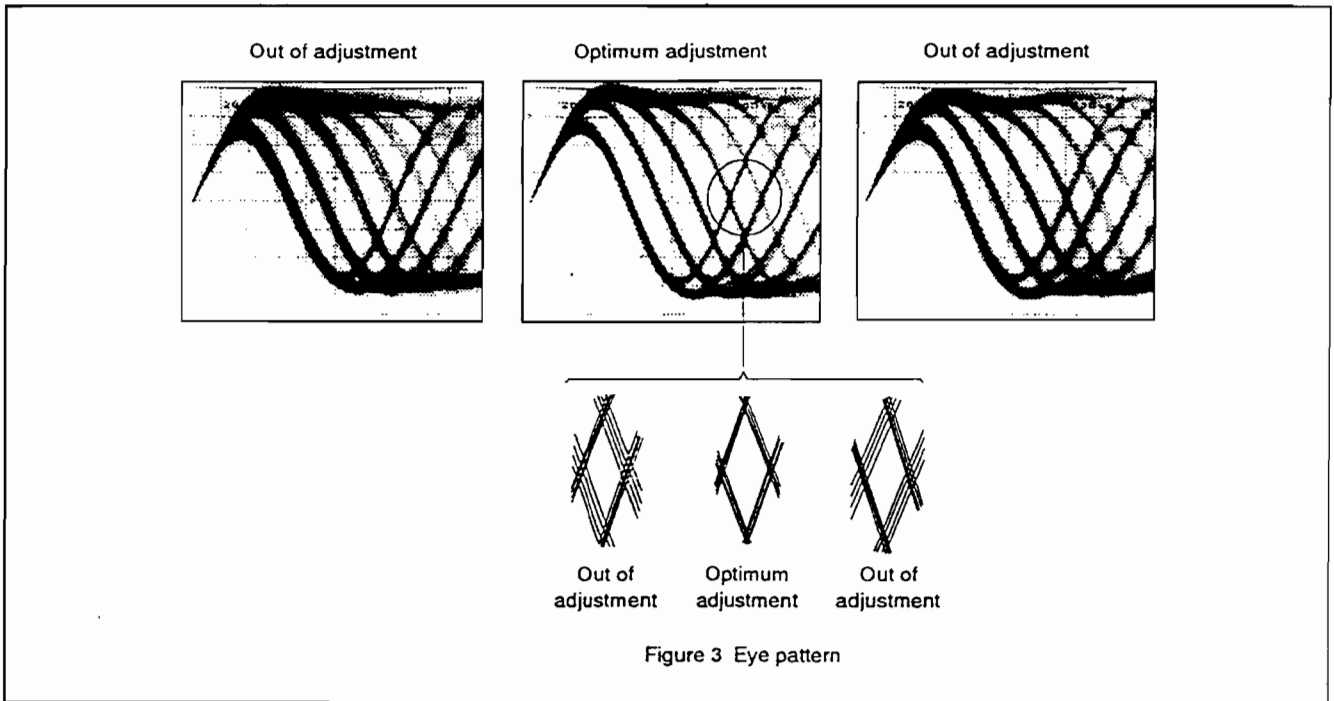

Figure 2



Adjustment locations



4. RF Level Verification

<ul style="list-style-type: none"> ● Objective 	To verify the playback RF signal amplitude		
<ul style="list-style-type: none"> ● Symptom when out of adjustment 	No play or no search		
<ul style="list-style-type: none"> ● Measurement instrument connections 	Connect the oscilloscope to TP301, Pin 1 (RF). [Settings] 50 mV/division 10 ms/division AC mode	<ul style="list-style-type: none"> ● Player state ● Adjustment location ● Disc 	Test mode, play None YEDS-7
<p>[Procedure]</p> <ol style="list-style-type: none"> 1. Move the pickup to midway across the disc (R=35 mm) with the FWD $\triangleright\triangleright$ or REV $\triangleleft\triangleleft$ key, then press the PGM (PROGRAM) key, the PLAY/PAUSE \triangleright/\square key twice in that order to close the respective servos and put the player into play mode. 2. Verify the RF signal amplitude is $1.2V_{p-p} \pm 0.2V$. 			

5. Focus Servo Loop Gain Adjustment

● Objective	To optimize the focus servo loop gain.		
● Symptom when out of adjustment	Playback does not start or focus actuator noisy.		
● Measurement instrument connections	See figure 4. [Settings] CH1 CH2 20 mV/division 5 mV/division X-Y mode	● Player state ● Adjustment location ● Disc	Test mode, play VR301 (FCS. GAN) YEDS-7

[Procedure]

1. Set the AF generator output to 1.2 kHz and 1 Vp-p.
2. Press the FWD >> or REV << key to move the pickup to halfway across the disc (R=35 mm), then press the PGM (PROGRAM) key, the PLAY/PAUSE >| key twice in that order to close the corresponding servos and put the player into play mode.
3. Adjust VR301 (FCS. GAN) so that the Lissajous waveform is symmetrical about the X axis and the Y axis.

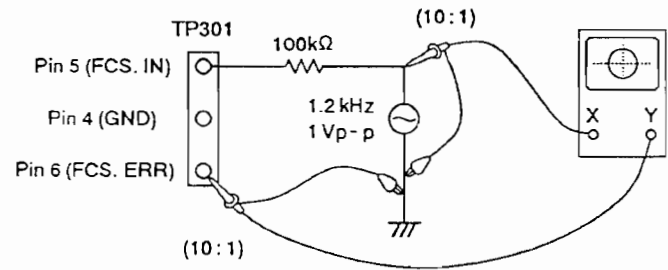
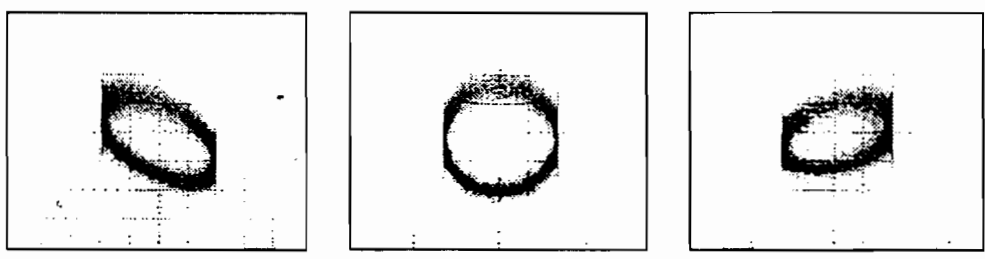

Figure 4

Focus Gain Adjustment



Higher gain

Optimum gain

Lower gain

6. Tracking Servo Loop Gain Adjustment

● Objective	To optimize the tracking servo loop gain.		
● Symptom when out of adjustment	Playback does not start, during searches the actuator is noisy, or tracks are skipped.		
● Measurement instrument connections	See Figure 5.	● Player state	Test mode, play
	[Settings] CH1 CH2 50 mV/division 20 mV/division X-Y mode	● Adjustment location	VR302 (TRK. GAN)
		● Disc	YEDS-7

[Procedure]

1. Set the AF generator output to 1.2 kHz and 2 Vp-p.
2. Press the FWD >> or REV << key to move the pickup to halfway across the disc (R=35 mm), then press the PGM (PROGRAM) key, the PLAY/PAUSE >/ || key twice in that order to close the corresponding servos and put the player into play mode.
3. Adjust VR302 (TRK. GAN) so that the Lissajous waveform is symmetrical about the X axis and the Y axis.

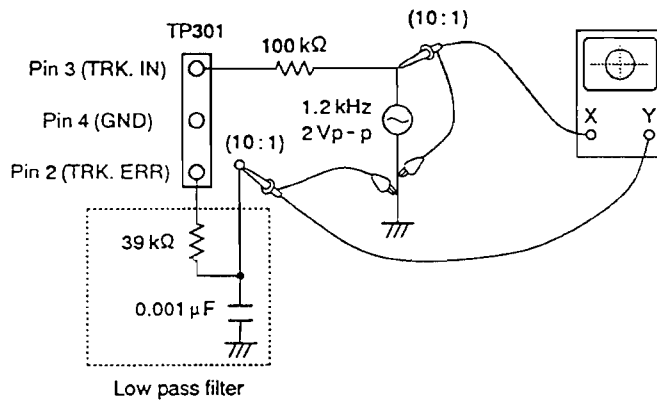
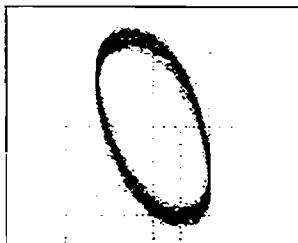
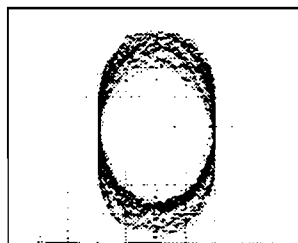

Figure 5

Tracking Gain Adjustment



Higher gain



Optimum gain

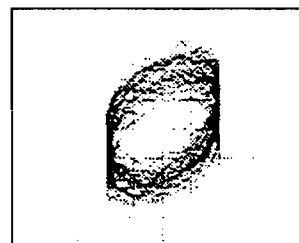

Lower gain

7. IC INFORMATION

- The information shown in the list is basic information and may not correspond exactly to that shown in the schematic diagrams.

■ SM5871AS (IC701)

- 1bit DAC

● Pin Function

No.	Pin Name	I/O	Function			
1	XTO	O	Output terminal of oscillation section.			
2	XVss	-	GND (0V) for X'tal section.			
3	DS	I	Normal/Double speed playback mode section . (DS=L : Normal playback mode) (DS=H : Double speed playback mode)			
4	CKO	O	Output clock of oscillation section . (DS=L : 384fs as same as XTI input frequency) (DS=H : 192fs as same as XTI input frequency)			
5	TSTN	I	Test terminal : Normally fix to H level.			
6	MODN	I	Mode control terminal.			
7	ATTN	I	Soft mute control terminal.	MODN		
				Selection	H	L
				H	Release the soft mute operation	Hold (fix) the soft mute operation
L	Soft mute operation					
8	LRCI	I	Sample rate (fs) clock of input data : H=L ch L=R ch			
9	BCKI	I	Bit clock of input data.			
10	DIN	I	Input data.			
11	DFS1	I	Deemphasis control terminal 1.	DFS1		
12	DFS2	I	Deemphasis control terminal 2.	Selection	L	H
				L	Deemphasis ON 44.1kHz	Deemphasis OFF
				H	Deemphasis ON 48.0kHz	Deemphasis ON 32.0kHz
13	MUTEO	O	Infinity · zero detection output.			
14	RSTN	I	System reset : H=Normal operation L=System reset			
15	DVss	-	Digital GND terminal (0V).			
16	DVDD	-	Digital VDD terminal (5V).			
17	AVDD1	-	Analog VDD terminal 1 (5V).			
18	LO	O	L ch PWM output (+).			
19	AVss1	-	Analog GND terminal 1 (0V).			
20	LON	O	L ch PWM output (-).			
21	AVDD2	-	Analog VDD terminal 2 (5V).			
22	AVDD3	-	Analog VDD terminal 3 (5V).			
23	RON	O	R ch PWM output (-).			
24	AVss2	-	Analog GND terminal 2 (0V).			
25	RO	O	R ch PWM output (+).			
26	AVDD4	-	Analog VDD terminal 4 (5V).			
27	XVDD	-	VDD terminal (5V) for X'tal section.			
28	XTI	I	Input terminal of oscillation section. (384fs : DS=L) (192fs : DS=H)			

8. FOR PDC - P630T/AD AND PDC - P530T/ADL

NOTES:

- Parts marked by "NSP" are generally unavailable because they are not in our Master Spare Parts List.
- The Δ mark found on some component parts indicates the importance of the safety factor of the part. Therefore, when replacing, be sure to use parts of identical designation.
- Parts marked by "☉" are not always kept in stock. Their delivery time may be longer than usual or they may be unavailable.

CONTRAST OF MISCELLANEOUS PARTS

PDC - P630T/AD, PDC - P530T/ADL and PDC - P630T/AEBM have the same construction except for the following :

Mark	Symbol & Description	Part No.			Remarks
		PDC - P630T/AEBM	PDC - P630T/AD	PDC - P530T/ADL	
NSP	MAIN UNIT	RWZ2858	RWZ2858	RWZ2856	
	SUB UNIT	RWZ2859	RWZ2859	RWZ2857	
	DIND UNIT	RWZ2865	RWZ2865	
	CONT UNIT	RWZ2868	RWZ2868	RWZ2867	
	Door panel L	REA1043	REA1043	REA1041	
	Door panel R	REA1044	REA1044	REA1042	
	Packing case	RHG1412	RHG1485	RHG1411	
	Spot lens	RNK1880	RNK1880	
	Front panel	RNT1162	RNT1162	RNT1161	
	Rear panel	RNA1638	RNA1712	RNA1711	

MAIN UNIT

RWZ2856 and RWZ2858 have the same construction except for the following :

Mark	Symbol & Description	Part No.		Remarks
		RWZ2858	RWZ2856	
NSP NSP	C535, C536	CFTYA183J50	
	C537, C538	CQMA752J50	CFTYA273J50	
	C539, C540	CFTXA562J50	
	R487, R488	RD1/6PM103J	
	R547, R548	RD1/6PM331J	
	R931, R932	RD1/6PM750J	
	CN29, CN30	B2B - PH - K - S	
	Connector	PNC - 205	
	Heat sink			

SUB UNIT

RWZ2857 and RWZ2859 have the same construction except for the following :

Mark	Symbol & Description	Part No.		Remarks
		RWZ2859	RWZ2857	
	IC601	NJM4558DX	
	Q411, Q412, Q431, Q432, Q806	2SC1740S	
	Q813, Q820	XDA144ES	
	Q814, Q821, Q826	XDC124ES	
	Q827, Q828	XDA114ES	
	D601, D602, D805	1SS254	
	C637	CKCYF473Z50	
	C638	CCCSL101J50	
	C639	CEAS010M50	
	C640	CCCSL271J50	
	C641	CEASR22M50	
	C804	CEASR47M50	
	R411, R412, R445, R446, R846	RD1/6PM103J	
	R435, R436	RD1/6PM153J	
	R611	RD1/6PM224J	
	R612	RD1/6PM391J	
	R613, R616, R617	RD1/6PM393J	
	R614	RD1/6PM472J	
	R615	RD1/6PM824J	
	R618	RD1/6PM473J	
	R803	RD1/6PM222J	
	R806	RD1/6PM472J	
	R807	RD1/6PM152J	
	R808	RD1/6PM561J	
	R816, R817	RD1/6PM124J	
	R832	RN1/6PQ1102F	RN1/6PQ1302F	
	R837	RD1/6PM223J	
	R842, R843	RD1/6PM223J	
	VR803	RCP1114	

CONT UNIT

Although RWZ2867 and RWZ2868 are different in part number, they have the same service parts.

9. PANEL FACILITIES

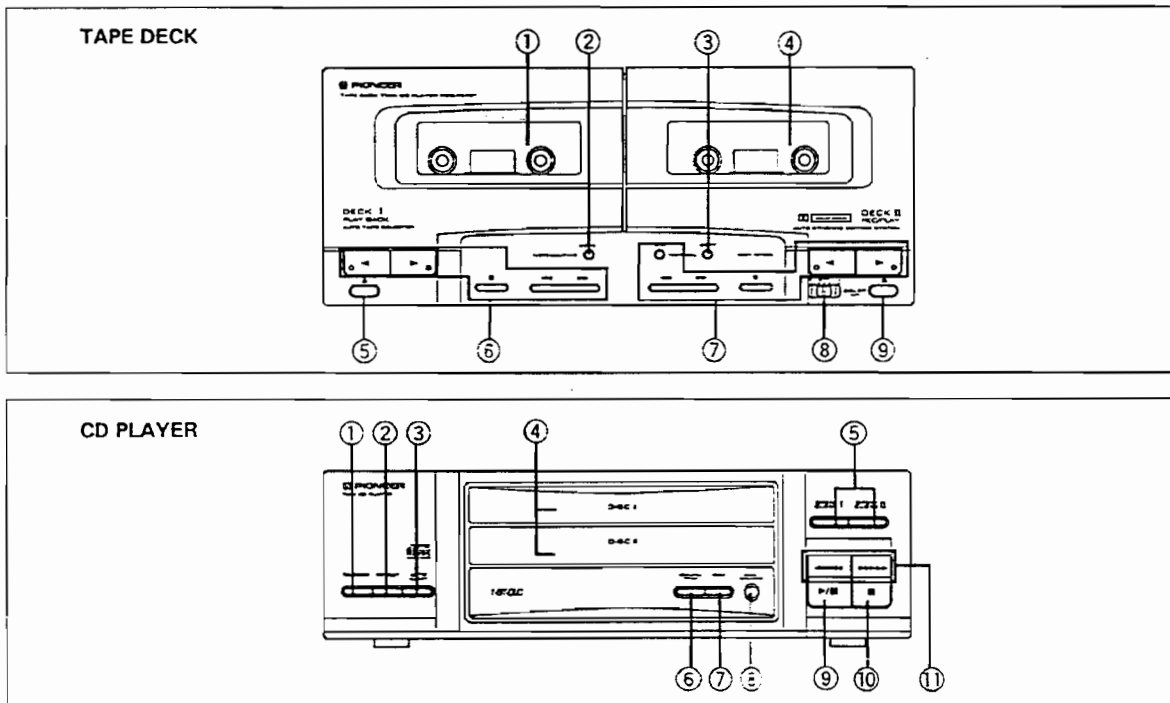

TAPE DECK

- ① Deck I cassette door
- ② ASES (Auto Synchro Editing System) NORMAL/FINE button (p. 16, 17)
- ③ COPY NORMAL/HIGH SPEED button (p. 15)
- ④ Deck II cassette door
- ⑤ Deck I eject button (▲) (p. 12)
- ⑥ Deck I operation buttons (Play ◀▶, Stop ■, Fast ◀◀▶▶) (p. 12, 13)
- ⑦ Deck II operation buttons (Play ◀▶, Stop ■, Fast ◀◀▶▶, Rec Pause ● II) (p. 12, 13, 14)
- ⑧ DOLBY* NR switch (p. 12)
- ⑨ Deck II eject button (▲) (p. 12, 14)

CD PLAYER

- ① RANDOM button (p. 9)
- ② REPEAT button (p. 9)
- ③ AUTO EJECT button (p. 9)
- ④ Disc trays (DISC I, DISC II)
- ⑤ OPEN/CLOSE I, II buttons (p. 6)
- ⑥ COMPU PGM button (p. 17)
- ⑦ PGM (Program) button (p. 10)
- ⑧ DISC CHANGE button (p. 6, 7)
- ⑨ Play/Pause button (▶/II) (p. 6)
- ⑩ Stop button (■) (p. 6)
- ⑪ Manual/Track search buttons (◀◀◦◦▶▶, ▶▶◦◦▶▶) (p. 7, 8)

• Dolby noise reduction manufactured under license from Dolby Laboratories Licensing Corporation. "DOLBY" and the double-D symbol  are trademarks of Dolby Laboratories Licensing Corporation.

10. SPECIFICATIONS

Cassette Deck Section

Systems	4 track, 2-channel stereo
Heads	Recording/playback head x 1 Playback head x 1 Erasing head x 1
Motor	DC servc motor x 2
Wow and Flutter	No more than 0.09 % (WRMS)
Frequency Response (-20 dB recording):	
TYPE II (HIGH/CrO ₂) tape	35 Hz to 15,000 Hz ±6 dB
TYPE I (Normal) tape	35 Hz to 14,000 Hz ±6 dB
Signal-to-Noise Ratio	56 dB (peak recording level, audible compensation)
Noise Reduction Effect	
With Dolby B-type NR ON	More than 10 dB (at 5 kHz)
With Dolby C-type NR ON	More than 19 dB (at 5 kHz)

CD Section

Type	Compact disc digital audio system
Frequency Response	4 Hz to 20 kHz
Signal to Noise Ratio	96 dB or more (EIAJ)

Miscellaneous

Dimensions	260 (W) x 180 (H) x 271 (D) mm
Weight (without package)	3.9 kg

Accessories

Operating Instructions	1
------------------------------	---

NOTE:

Specifications and design subject to possible modification without notice due to improvement.