

Service Manual

PIONEER
The Art of Entertainment

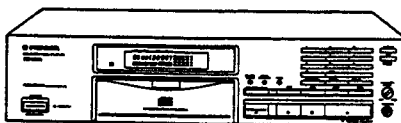

ORDER NO.
ARP2471

COMPACT DISC PLAYER

PD-S501

PD-S501 HAS THE FOLLOWING:

Type	Power Requirement	Remarks
KU	AC120V only	
KC	AC120V only	
KUXJS	AC120V only	
KCXJS	AC120V only	

- This manual is applicable to PD-S501/KU, KC, KUXJS and KCXJS types.
- For KC, KUXJS and KCXJS types, refer to page 42.

CONTENTS

1. SAFETY INFORMATION	2
2. DISASSEMBLY	3
3. EXPLODED VIEWS, PACKING AND PARTS LIST	4
4. SCHEMATIC DIAGRAM.....	11
5. PCB CONNECTIONS DIAGRAM.....	17
6. PCB PARTS LIST	25
7. ADJUSTMENTS	27
8. FOR PD-S501/KC, KUXJS AND KCXJS TYPES	42
9. PANEL FACILITIES.....	43
10. SPECIFICATIONS	43

This service manual is intended for qualified service technicians; it is not meant for the casual do-it-yourselfer. Qualified technicians have the necessary test equipment and tools, and have been trained to properly and safely repair complex products such as those covered by this manual.

Improperly performed repairs can adversely affect the safety and reliability of the product and may void the warranty. If you are not qualified to perform the repair of this product properly and safely, you should not risk trying to do so and refer the repair to a qualified service technician.

WARNING

Lead in solder used in this product is listed by the California Health and Welfare agency as a known reproductive toxicant which may cause birth defects or other reproductive harm (California Health & Safety Code, Section 25249.5).

When servicing or handling circuit boards and other components which contain lead in solder, avoid unprotected skin contact with the solder. Also, when soldering do not inhale any smoke or fumes produced.

1. SAFETY INFORMATION

(FOR USA MODEL ONLY)

1. SAFETY PRECAUTIONS

The following check should be performed for the continued protection of the customer and service technician.

LEAKAGE CURRENT CHECK

Measure leakage current to a known earth ground (water pipe, conduit, etc.) by connecting a leakage current tester such as Simpson Model 229-2 or equivalent between the earth ground and all exposed metal parts of the appliance (input/output terminals, screwheads, metal overlays, control shaft, etc.). Plug the AC line cord of the appliance directly into a 120V AC 60Hz outlet and turn the AC power switch on. Any current measured must not exceed 0.5mA.

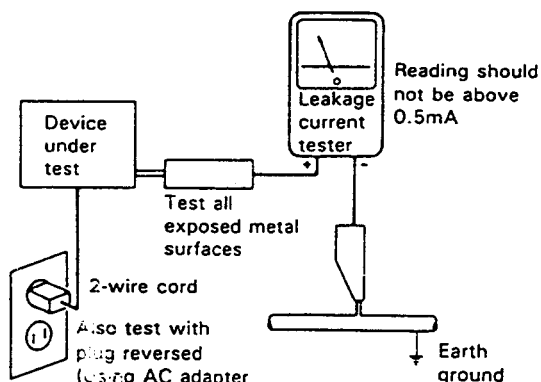

AC Leakage Test

ANY MEASUREMENTS NOT WITHIN THE LIMITS OUTLINED ABOVE ARE INDICATIVE OF A POTENTIAL SHOCK HAZARD AND MUST BE CORRECTED BEFORE RETURNING THE APPLIANCE TO THE CUSTOMER.

2. PRODUCT SAFETY NOTICE

Many electrical and mechanical parts in the appliance have special safety related characteristics. These are often not evident from visual inspection nor the protection afforded by them necessarily can be obtained by using replacement components rated for voltage, wattage, etc. Replacement parts which have these special safety characteristics are identified in this Service Manual.

Electrical components having such features are identified by marking with a Δ on the schematics and on the parts list in this Service Manual. The use of a substitute replacement component which does not have the same safety characteristics as the PIONEER recommended replacement one, shown in the parts list in this Service Manual, may create shock, fire, or other hazards.

Product Safety is continuously under review and new instructions are issued from time to time. For the latest information, always consult the current PIONEER Service Manual. A subscription to, or additional copies of, PIONEER Service Manual may be obtained at a nominal charge from PIONEER.

2. DISASSEMBLY

REMOVE THE TRAY PANEL AND THE TRAY LENS

Hold the tray panel with your hands as the figure shown right, and grasp the tray with your thumbs and then lift the tray panel up while pulling it toward you with the other fingers. (Figs . 1 and 2)

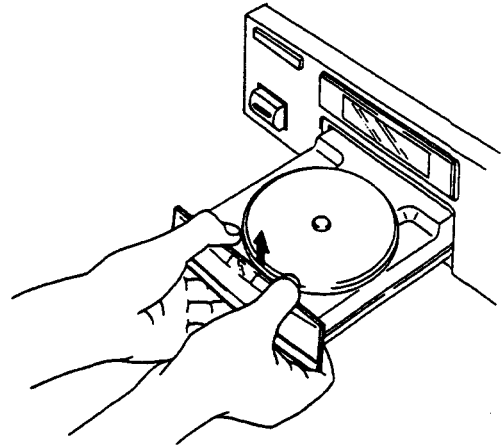

Fig. 1

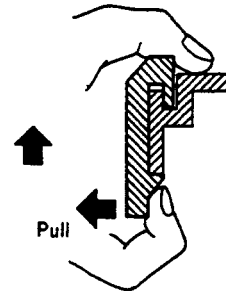

Fig. 2

INSTALL THE TRAY PANEL AND THE TRAY LENS

Align the tray panel with the grooves located at both edges of the tray while holding the tray lens with you fingers, and then press it down till it stops. (Fig. 3)

Hold the tray panel and the tray as shown in Fig. 4 and slide them down till you hear a click sound while pressing strongly with your thumbs. (Figs. 4 and 5)

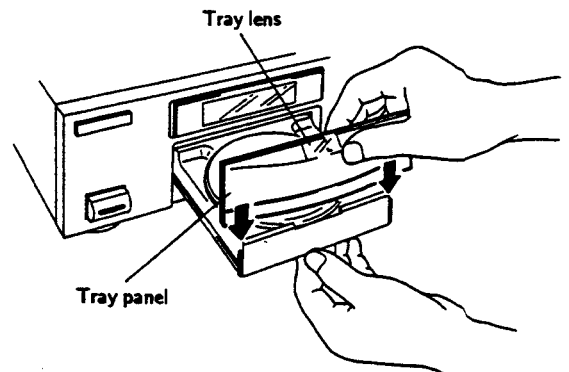

Fig. 3

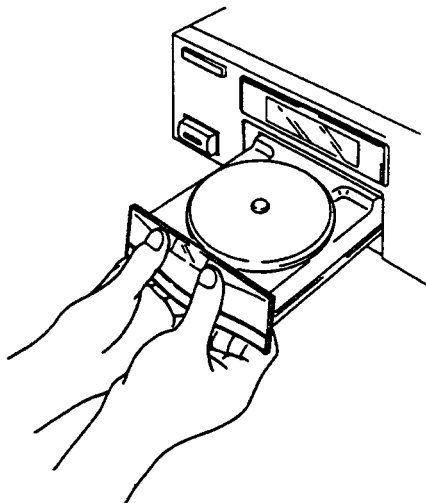

Fig. 4

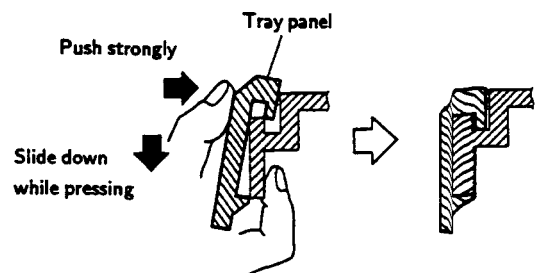

Fig. 5

3. EXPLODED VIEWS, PACKING AND PARTS LIST

NOTES:

- The parts with an encircled number are generally unavailable because they are not in our Master Spare Parts List.
- The Δ mark found on some component parts indicates the importance of the safety factor of the part. Therefore, when replacing, be sure to use parts of identical designation.
- Parts marked by "⊙" are not always kept in stock. Their delivery time may be longer than usual or they may be unavailable.

3.1 EXTERIOR

Parts List

Mark	No.	Description	Part No.
	1	Screw	IBZ30P080FCC
	2	Screw	BBZ30P060FCC
	3	Screw	IBZ30P150FCC
	4	Screw	BSZ30P070FMC
	5	Screw	BBZ30P080FCC
	6	Screw	IBZ30P060FCC
	7	Screw	FBT40P080FZK
	8	Bonnet	PYY1162
Δ	9	AC power cord	PDG1015
Δ	10	Strain relief	CM-22C
Δ	11	Power transformer	PTT1237
	12	Insulator	PNW1912
	13	Headphone knob	PAC1600
	14	Tray name plate	PNW2135
	15	Function panel assembly	PEA1194
⊙	16	Mother board assembly	PWM1660
	17	Display window A	PAM1544
	18	Cord holder	RNH-184
	19	LED lens	PNW2019
	20	Power button	PAC1540
	21	10 key assembly	PAC1653
	22	
	23	Play button A	PAC1634
	24	Screw	PPZ30P100FMC
	25	32P F.F.C./30V	PDD1109
	26	Tray lens	PNW1950
	27	Screw	PDZ30P050FMC
	51	Headphone PCB assembly	PWZ2279
	52	Under base	PNA1733
	53	
	54	PCB spacer	PNY-404
	55	Rear base	PNA1727
	56	SW PCB assembly	PWZ2278
	57	PIONNER badge	PAM1407
	58	Function board assembly	PWZ2277
	59	Function panel A	PNW2130

Exterior

PD-S501

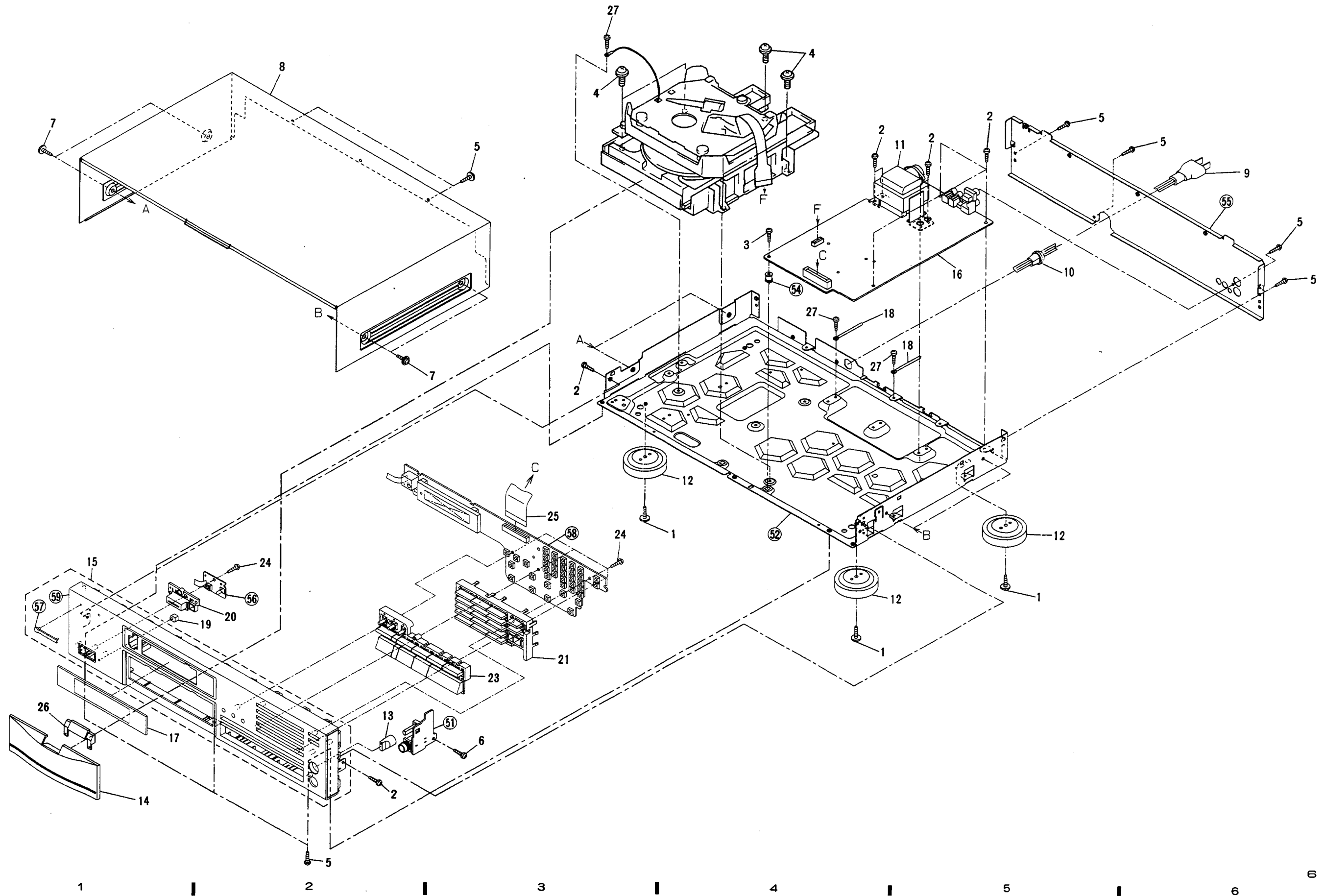

Parts List of Mechanism section

Mark No.	Description	Parts No.	Mark No.	Description	Parts No.
1	Lever switch (S601)	DSK1003	101	
2	Screw(steel)	PBA1027	102	Loading base	PNW1995
3	Rubber belt	PEB1186	103	Table bearing assembly	PXA1383
4	Motor pulley	PNW1634	104	Servo mechanism assembly	PXA1384
5	Drive gear	PNW1996	105	Earth lead unit (300V)	PDF1104
6	Synchro lever	PNW2168	106	Motor base	PNB1211
7	Gear pulley	PNW1998	107	Mechanism base assembly	PXA1385
8	SW head	PNW1999	108	Mechanism chassis	PNW1604
9	Float base	PNW2000	109	Binder	PEC-107
10	Left cam	PNW2001	110	Connector assembly	PDE1130
11	Right cam	PNW2002	111	Turn table (AL)	PNR1044
12	Compression spring	PBH1120			
13	Tention spring	PBH1121			
14	Float(rubber)	PEB1014			
15	Table rubber sheet	PEB1181			
16	Tray	PNW2003			
17	Table guide	PNW2004			
18	Lock plate	PNW2005			
19	DC motor(0.75W)	PXM1010			
20	Rubber bush	PEB1031			
21	Rubber bush	PEB1170			
22	Screw	BMZ26P040FMC			
23	Screw	BPZ26P060FMC			
24	Screw	BPZ26P060FMC			
25	Screw	IPZ20P080FMC			
26	Stop ring	YE20S			
27	Turn table assembly	PEA1199			
29	Push switch	DSG1014			
30	Spring	PBH1009			
31	Spring	PBH1084			
32	Plate spring	PBK1057			
33	Belt(square)	PEB1072			
34	Screw	PLA1003			
35	Guide bar	PLA1071			
36	Pulley	PNW1066			
37	Half nut	PNW1605			
38	Motor pulley	PNW1634			
39	Screw	PBZ30P080FMC			
40	DC motor(1.7W)	PXM1013			
41	Screw	BPZ20P080FZK			
42	Screw	JFZ20P025FMC			
43	Screw	PBZ30P060FMC			
44	Screw	PMZ20P030FMC			
45	Pick up assembly	PEA1030			
46	DC motor assembly(With oil)	PEA1156			
47	Semi-fixed VR(3.3K)	PCP1008			
48	Caution label	PRW1244			
49	Disc table	PNW1067			
50	Shaft holder	PNB1382			

• How to install the disc table

- 1 Use nippers or other tool to cut the two sections marked ① in figure 1. Then remove the spacer.
- 2 While supporting the spindle motor shaft with the stopper, put spacer on top of the motor base (angled so it doesn't touch section ②), and stick the disc table on top (takes about 9kg pressure). Take off the spacer.

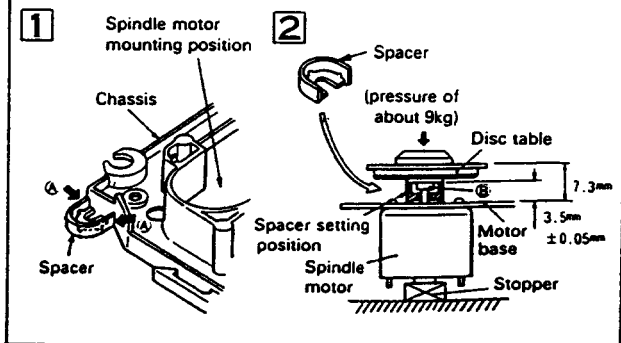

3.3 PACKING

Parts List

Mark	No.	Description	Part No.
	1	
	2	Cord with plug (mini plug)	PDE-319
	3	Cord with pin plug	PDE1109
	4	Operating instructions (English)	PRB1160
	5	Remote control unit (CU-PD046)	PWW1061
	6	Battery lid	PZN1010
	7	Styrol protector F	PHA1192
	8	Styrol protector R	PHA1193
	9	CD packing case	PHG1751
	10	
	11	Sheet	Z23-007
101		Mangan battery (R03, AAA)	VEM-022

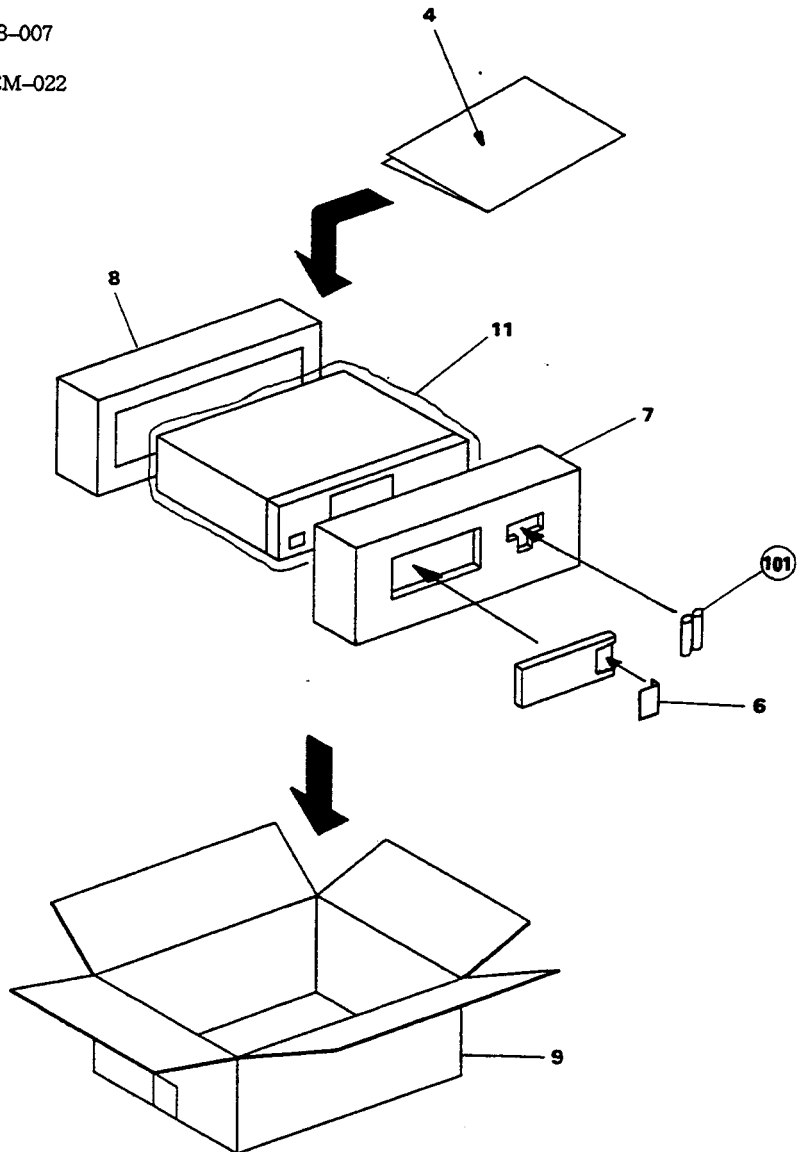
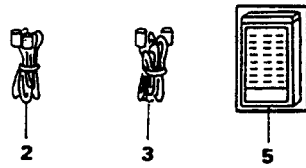

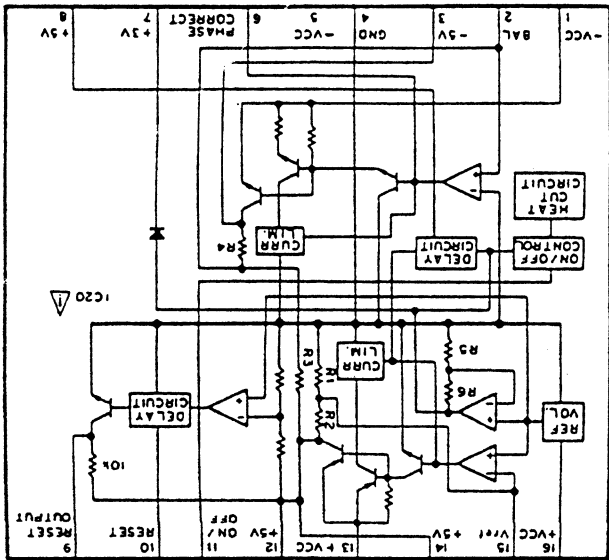

IC20: TA2019P

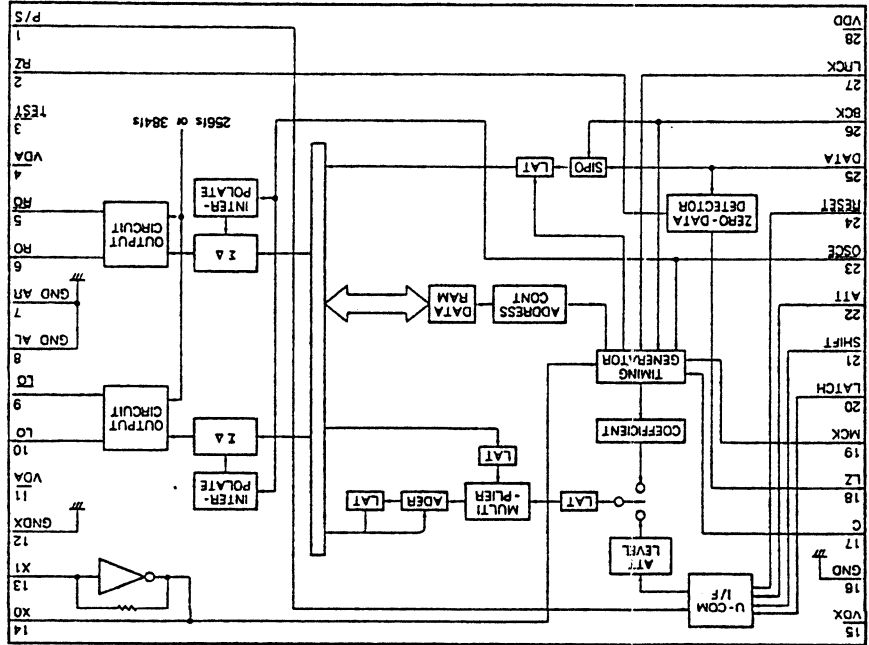

IC401: PD2026A

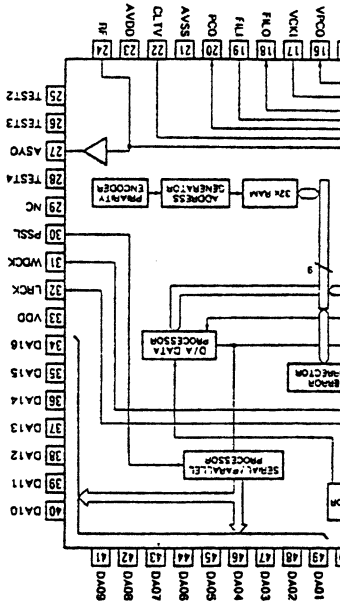

4. SCHEMATIC DIAGRAM

4.1 WAVE FORMS

Note: The encircled numbers denote measuring points in the schematic diagram.

*1 50T-JUMP: After switching to the pause mode, press the manual search key.

*2 FOCUS-IN: Press the key without loading a disc.

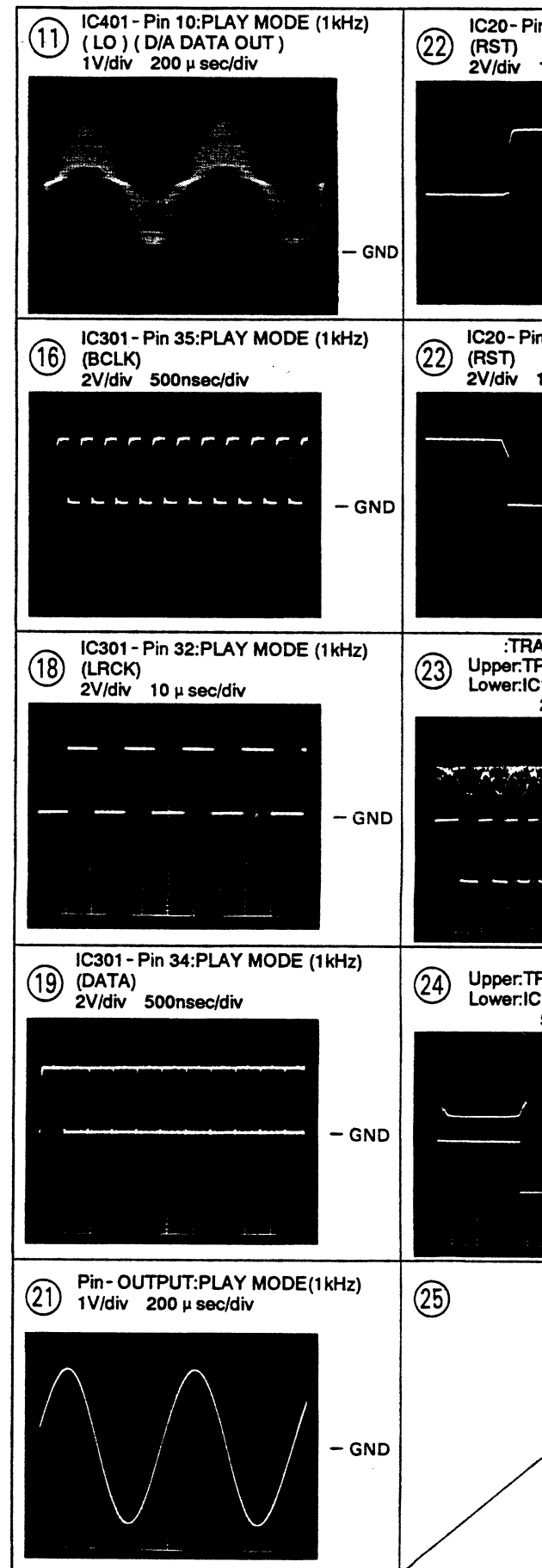
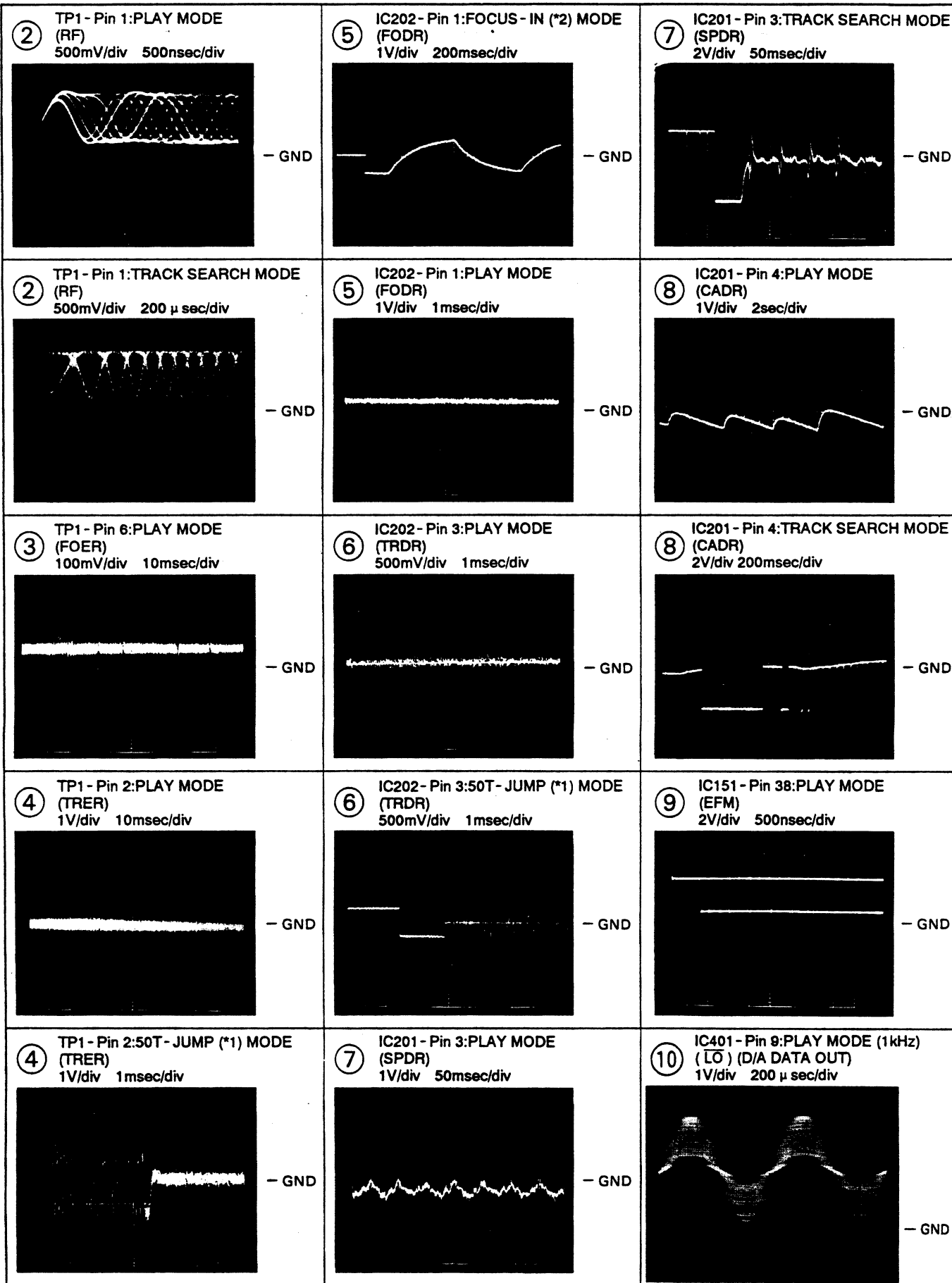

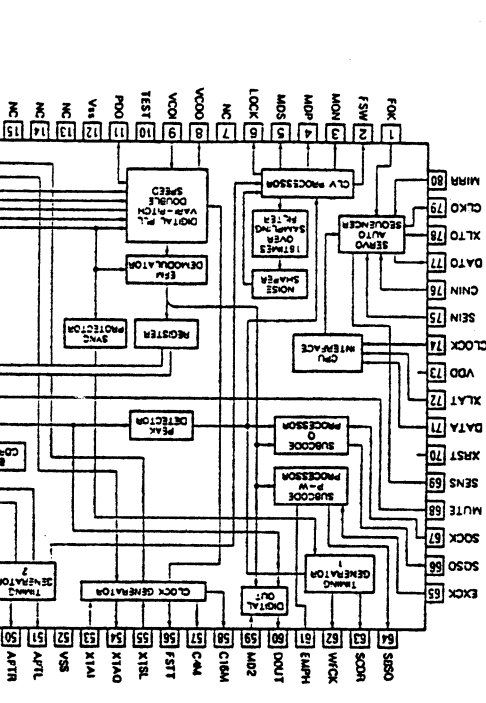

IC301: CXD2500AQ

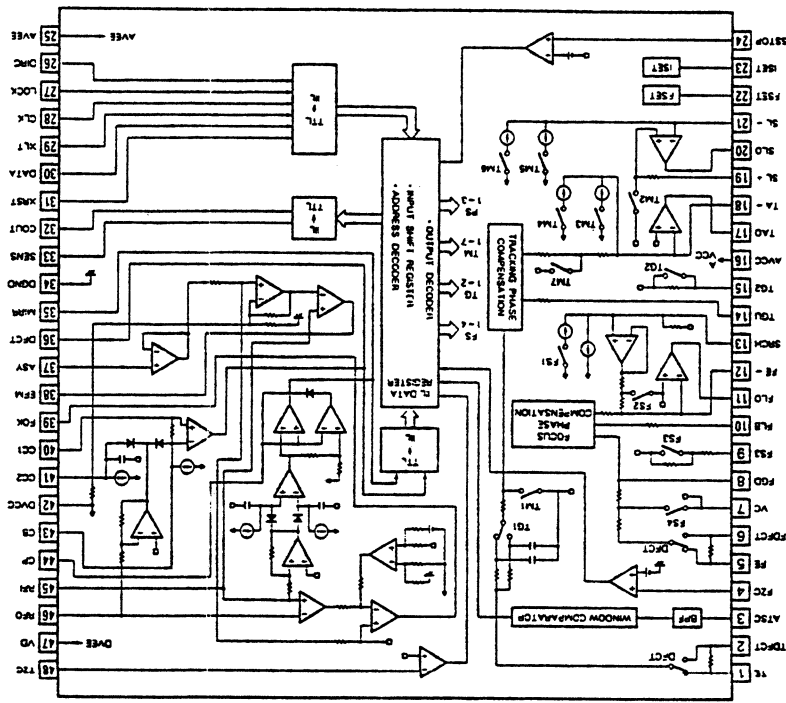

IC151: CXA1372S

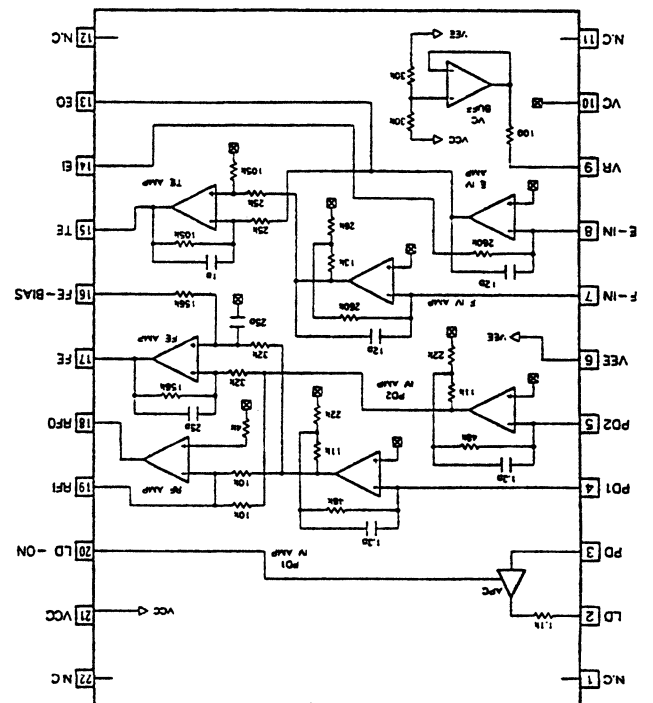

IC101: CXA1471S

● IC BLOCK DIAGRAMS

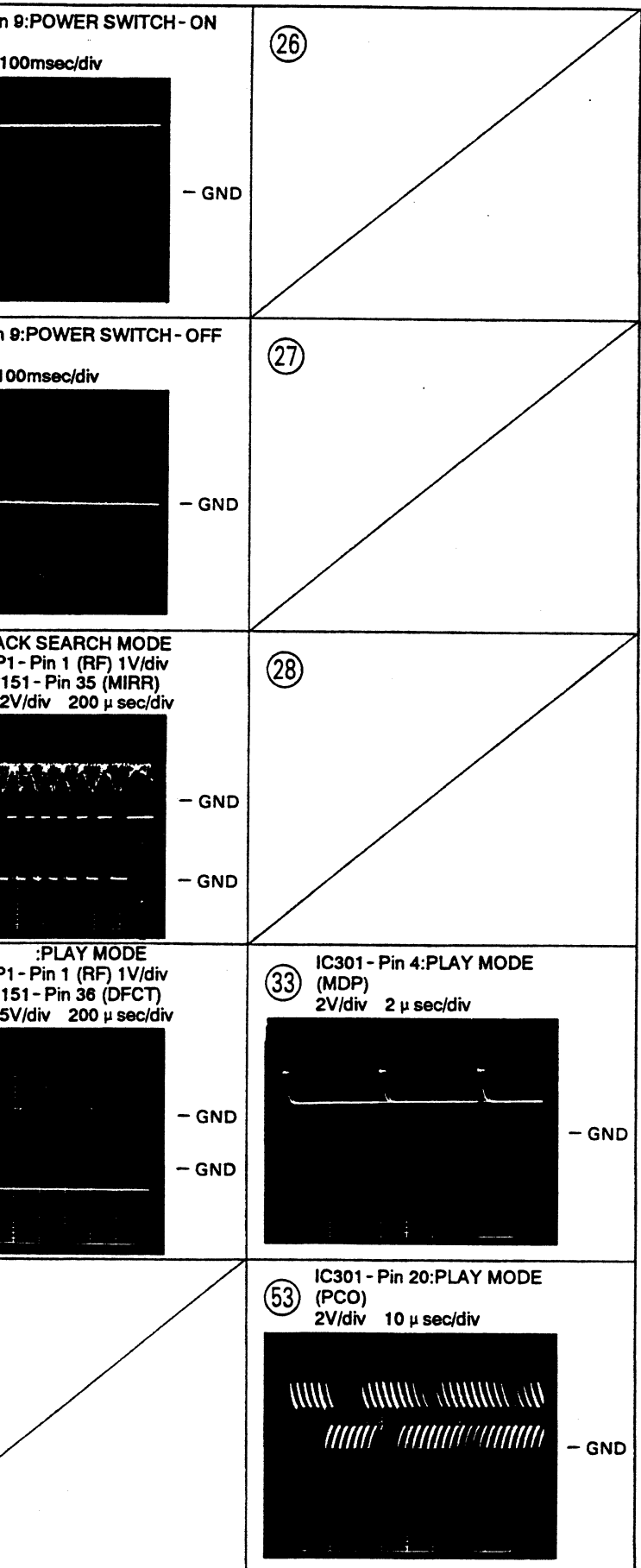

1. RESISTORS :
 Indicated in Ω, 1/4W, 1/6W, 1/8W, ± 5% tolerance unless otherwise noted k; kΩ, M; MΩ, (F); ± 1%, (G); ± 2%, (K); ± 10%, (M); ± 20% tolerance.
2. CAPACITORS :
 Indicated in capacity (μF) / voltage (V) unless otherwise noted p; pF. Indication without voltage is 50V except electrolytic capacitor.
3. VOLTAGE CURRENT :
 ; DC voltage (V) at play state.
 ; DC current at play state.
 ; Value in () is DC current at stop state.
4. OTHERS :
 ; Signal route.
 ; Adjusting point.
 The Δ mark found on some component parts indicates the importance of the safety factor of the part. Therefore, when replacing, be sure to use parts of identical designation.
 * marked capacitors and resistors have parts numbers.

This is the basic schematic diagram, but the actual circuit may vary due to improvements in design.

4.2 SCHEMATIC DIAGRAM

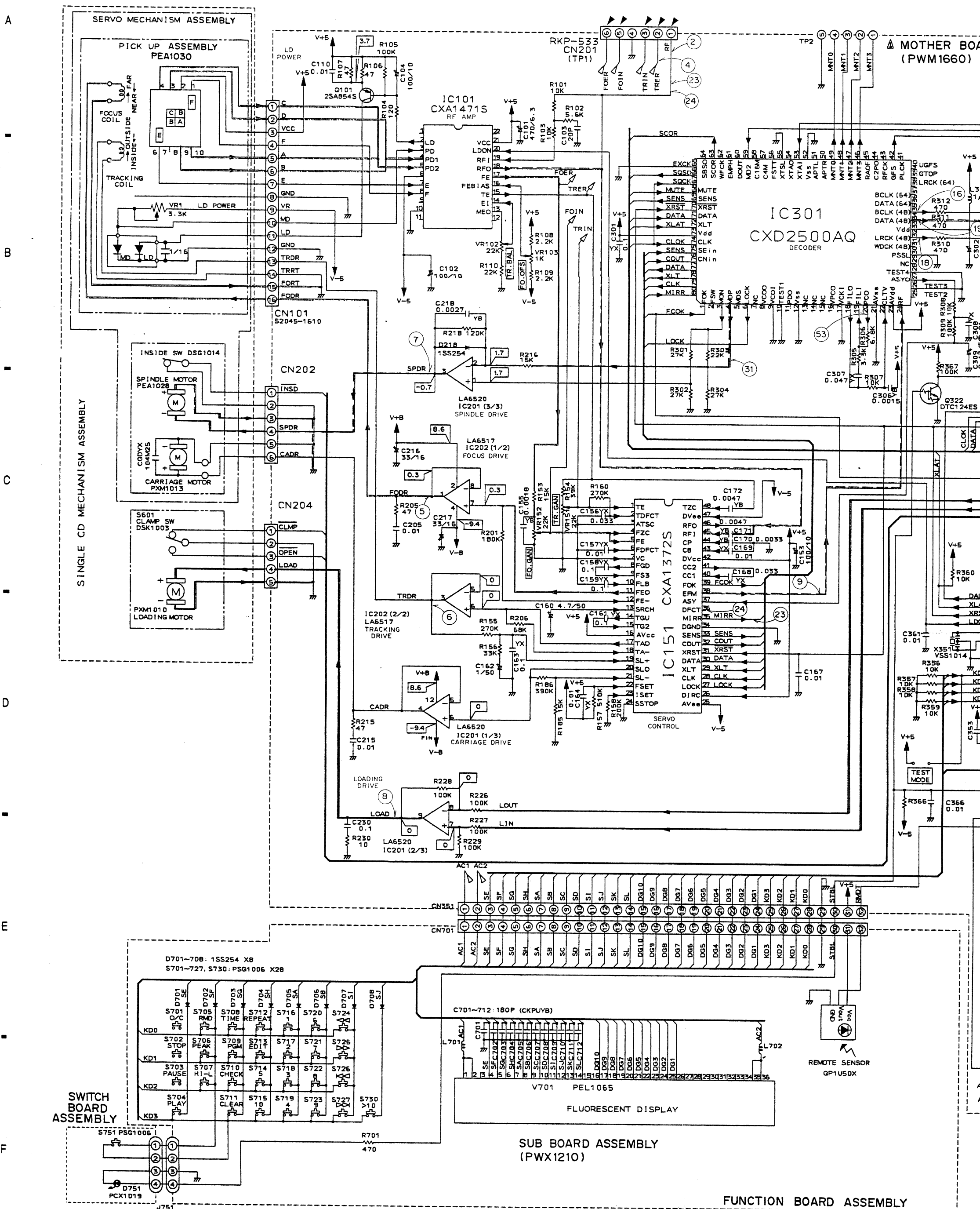

MOTHER BOARD ASSEMBLY (PWM1660)

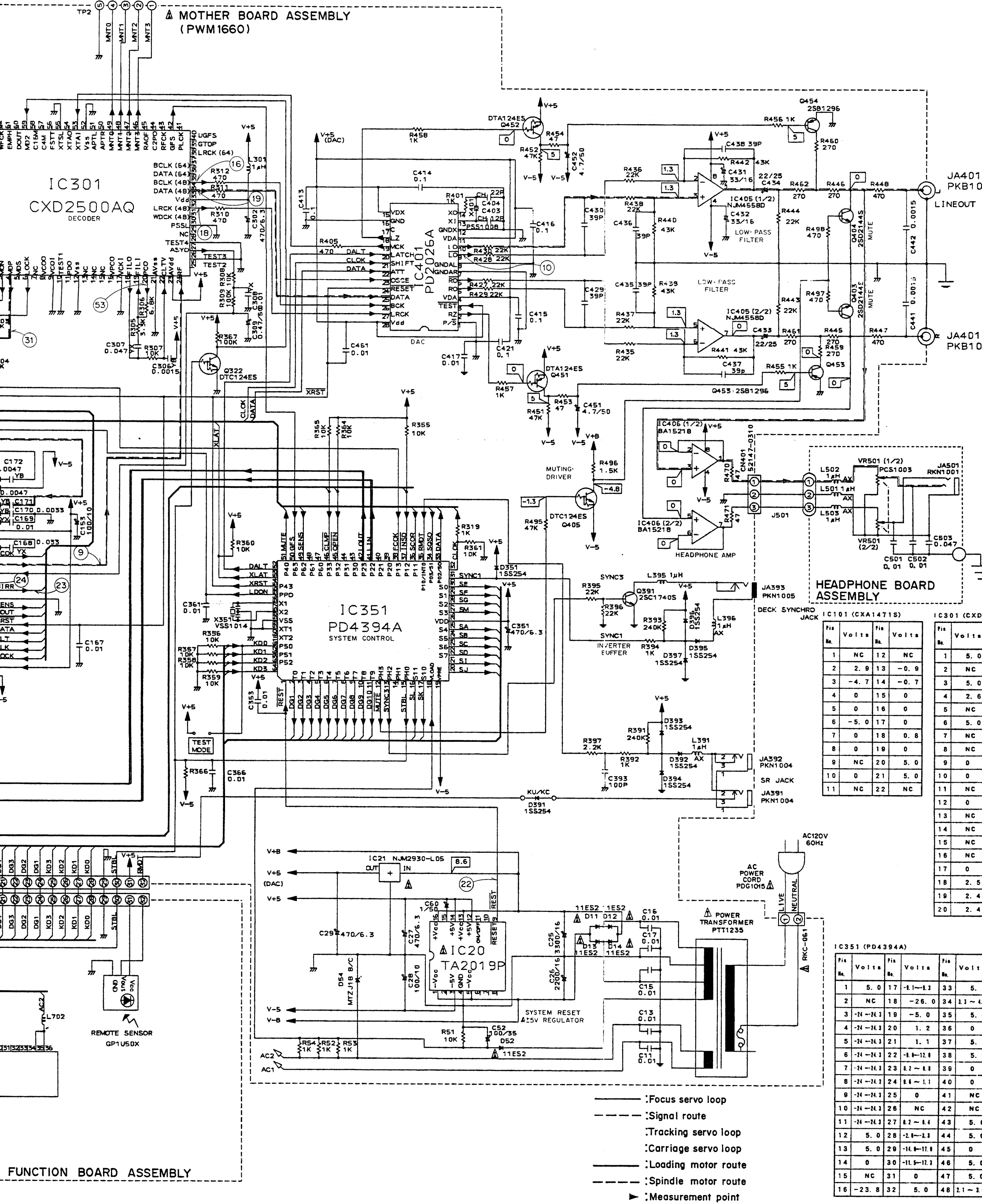

HEADPHONE BOARD ASSEMBLY

Pin No.	Volts	Pin No.	Volts	Pin No.	Volts
1	NC	12	NC	1	5.0
2	2.9	13	-0.9	2	NC
3	-4.7	14	-0.7	3	5.0
4	0	15	0	4	2.6
5	0	16	0	5	NC
6	-5.0	17	0	6	5.0
7	0	18	0.8	7	NC
8	0	19	0	8	NC
9	NC	20	5.0	9	0
10	0	21	5.0	10	0
11	NC	22	NC	11	NC
12	0			12	0
13	NC			13	NC
14	NC			14	NC
15	NC			15	NC
16	NC			16	NC
17	0			17	0
18	2.5			18	2.5
19	2.4			19	2.4
20	2.4			20	2.4

IC351 (PD4394A)

Pin No.	Volts	Pin No.	Volts	Pin No.	Volts
1	5.0	17	-1.1~1.1	33	5.0
2	NC	18	-26.0	34	1.1~4.0
3	-24~-24.3	19	-5.0	35	5.0
4	-24~-24.3	20	1.2	36	0
5	-24~-24.3	21	1.1	37	5.0
6	-24~-24.3	22	-1.0~12.0	38	5.0
7	-24~-24.3	23	0.2~0.8	39	0
8	-24~-24.3	24	0.0~1.1	40	0
9	-24~-24.3	25	0	41	NC
10	-24~-24.3	26	NC	42	NC
11	-24~-24.3	27	0.2~0.8	43	5.0
12	5.0	28	-2.0~1.1	44	5.0
13	5.0	29	-11.0~11.0	45	0
14	0	30	-11.0~11.0	46	5.0
15	NC	31	0	47	5.0
16	-23.8	32	5.0	48	2.1~1.1

- :Focus servo loop
- - - :Signal route
- :Tracking servo loop
- :Carriage servo loop
- :Loading motor route
- - - :Spindle motor route
- ▲ :Measurement point

FUNCTION BOARD ASSEMBLY

ARD ASSEMBLY

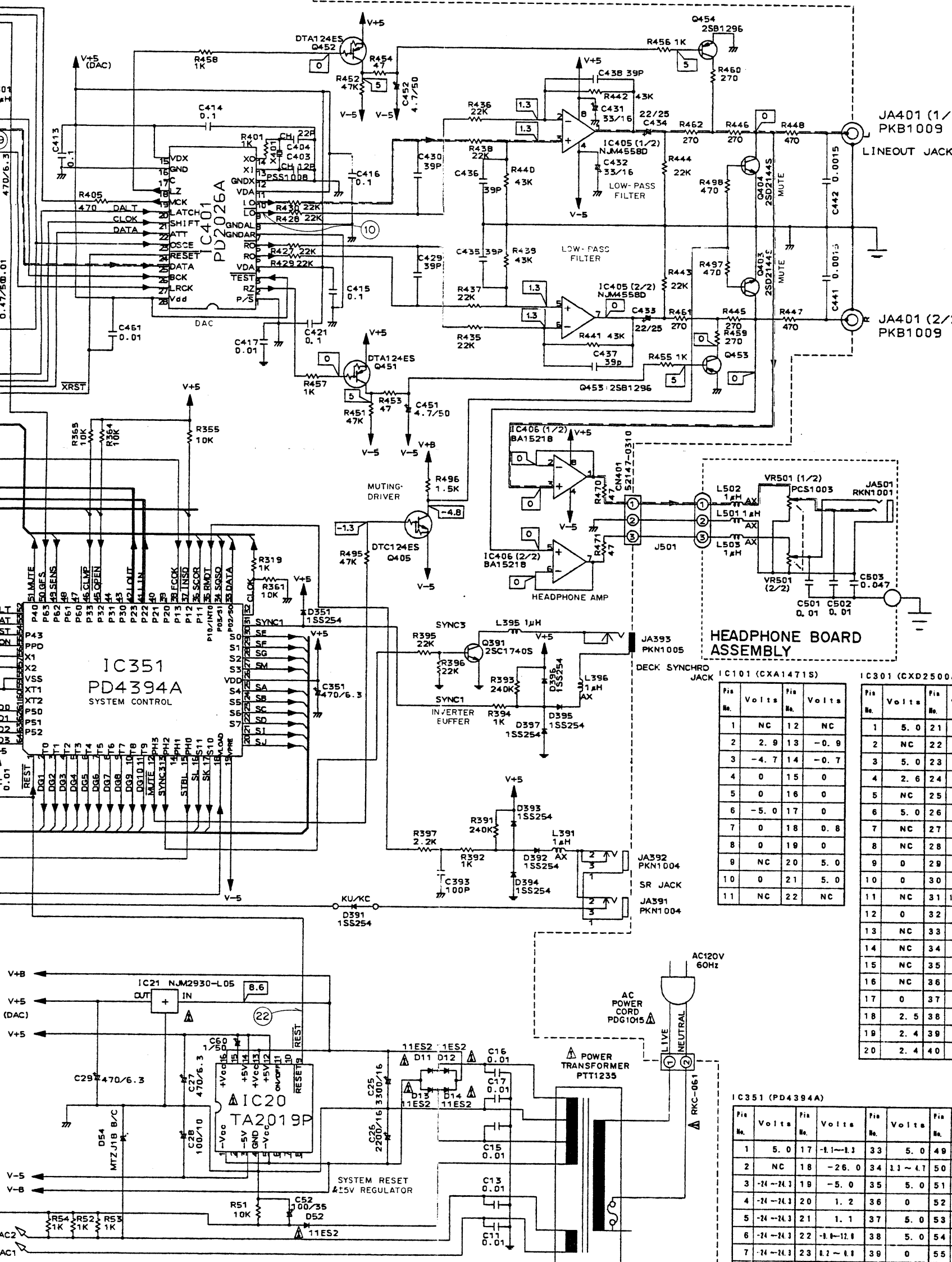

IC151 (CXA1372S)

Pin No.	Volts	Pin No.	Volts
1	0	25	-5.0
2	0	26	5.0
3	0	27	5.0
4	0	28	5.0
5	0	29	5.0
6	0	30	5.0
7	0	31	5.0
8	0	32	0
9	0	33	5.0
10	0	34	0
11	1.0	35	0
12	0	36	NC
13	0.2	37	2.5
14	0	38	2.5
15	0	39	5.0
16	5.0	40	-1.5
17	0	41	-1.7
18	0	42	5.0
19	0	43	-0.7
20	1.2 ~ 1.1	44	-1.6
21	0	45	0
22	-4.0	46	0.8
23	1.8	47	-5.0
24	0	48	0

IC401 (PD2026A)

Pin No.	Volts	Pin No.	Volts
1	0	15	5.0
2	0	16	0
3	5.0	17	NC
4	5.0	18	0
5	2.4	19	2.0
6	2.6	20	5.0
7	0	21	5.0
8	0	22	5.0
9	2.6	23	5.0
10	2.4	24	5.0
11	5.0	25	2.4
12	0	26	2.4
13	2.4	27	2.4
14	2.4	28	5.0

IC101 (CXA1471S)

Pin No.	Volts	Pin No.	Volts
1	NC	12	NC
2	2.9	13	-0.9
3	-4.7	14	-0.7
4	0	15	0
5	0	16	0
6	-5.0	17	0
7	0	18	0.8
8	0	19	0
9	NC	20	5.0
10	0	21	5.0
11	NC	22	NC

IC301 (CXD2500A0)

Pin No.	Volts	Pin No.	Volts	Pin No.	Volts	Pin No.	Volts
1	5.0	21	0	41	NC	61	NC
2	NC	22	2.5	42	5.0	62	NC
3	5.0	23	5.0	43	NC	63	NC
4	2.6	24	2.5	44	NC	64	NC
5	NC	25	NC	45	NC	65	0
6	5.0	26	0	46	4.4	66	1.1 ~ 1.6
7	NC	27	2.5	47	0	67	5.0
8	NC	28	NC	48	0	68	0
9	0	29	0	49	1 ~ 1.3	69	1.1 ~ 1.1
10	0	30	NC	50	NC	70	5.0
11	NC	31	1.1 ~ 1.2	51	NC	71	5.0
12	0	32	2.5	52	0	72	5.0
13	NC	33	5.0	53	2.5	73	5.0
14	NC	34	2.5	54	NC	74	5.0
15	NC	35	NC	55	0	75	5.0
16	NC	36	NC	56	NC	76	0
17	0	37	NC	57	NC	77	5.0
18	2.5	38	NC	58	NC	78	5.0
19	2.4	39	NC	59	0	79	5.0
20	2.4	40	NC	60	NC	80	0

IC351 (PD4394A)

Pin No.	Volts	Pin No.	Volts	Pin No.	Volts	Pin No.	Volts
1	5.0	17	-1.1 ~ -1.1	33	5.0	49	5.0
2	NC	18	-2.6	34	1.1 ~ 1.1	50	5.0
3	-2.1 ~ -2.1	19	-5.0	35	5.0	51	0
4	-2.1 ~ -2.1	20	1.2	36	0	52	5.0
5	-2.1 ~ -2.1	21	1.1	37	5.0	53	5.0
6	-2.1 ~ -2.1	22	-1.1 ~ -1.1	38	5.0	54	0
7	-2.1 ~ -2.1	23	0.2 ~ 0.2	39	0	55	5.0
8	-2.1 ~ -2.1	24	0.6 ~ 1.1	40	0	56	2.5
9	-2.1 ~ -2.1	25	0	41	NC	57	2.5
10	-2.1 ~ -2.1	26	NC	42	NC	58	0
11	-2.1 ~ -2.1	27	0.2 ~ 1.4	43	5.0	59	0
12	5.0	28	-2.1 ~ -1.3	44	5.0	60	NC
13	5.0	29	-1.1 ~ -1.1	45	0	61	0
14	0	30	-1.1 ~ -1.1	46	5.0	62	0
15	NC	31	0	47	5.0	63	0
16	-2.3	32	5.0	48	1.1 ~ 1.1	64	0

- : Focus servo loop
- - - - - : Signal route
- : Tracking servo loop
- : Carriage servo loop
- : Loading motor route
- : Spindle motor route
- ▶ : Measurement point

5. PCB CONNECTIONS DIAGRAM

• View from component side

MOTHER BOARD ASSEMBLY (PWM1660)

P.C.B. pattern diagram indication	Corresponding part symbol	Part name	P.C.B. pattern diagram indication	Corresponding part symbol	Part name
		Transistor			Ceramic capacitor
		FET			Mylar capacitor
		Diode			Styro capacitor
		Zener diode			Electrolytic capacitor (Non polarized)
		LED			Electrolytic capacitor (Noiseless)
		Varactor			Electrolytic capacitor (Polarized)
		Tact switch			Power capacitor
		Resistor array			Semi-fixed resistor
		Resistor			Inductor
		Coil			Resonator
		Transformer			Thermistor
		Filter			

- This P.C.B. connection diagram is viewed from the parts mounted side.
- The parts which have been mounted on the board can be replaced with those shown with the corresponding wiring symbols listed in the above Table.
- The capacitor terminal marked with shows negative terminal.
- The diode marked with shows cathode side.
- The transistor terminal marked with shows emitter.

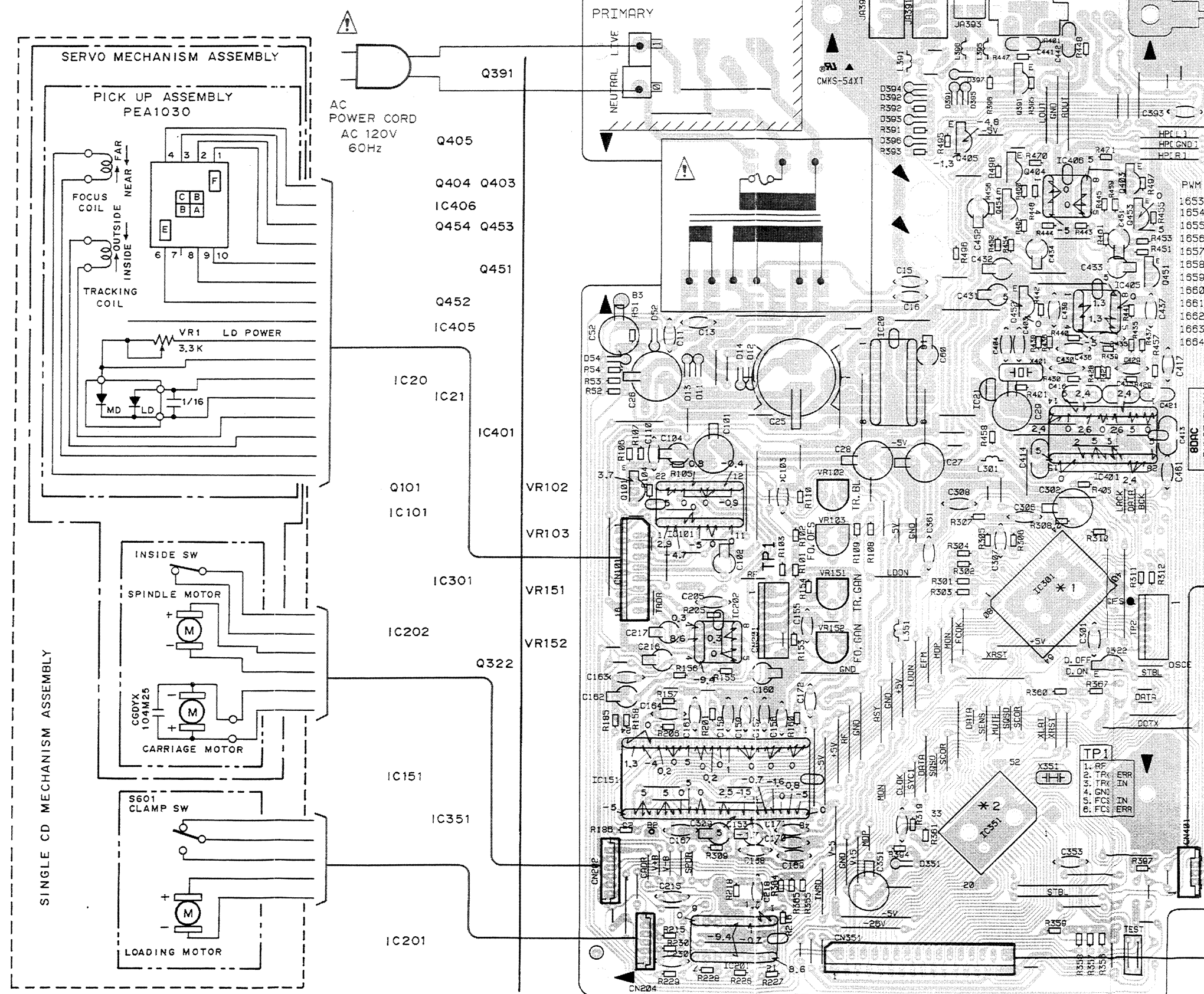

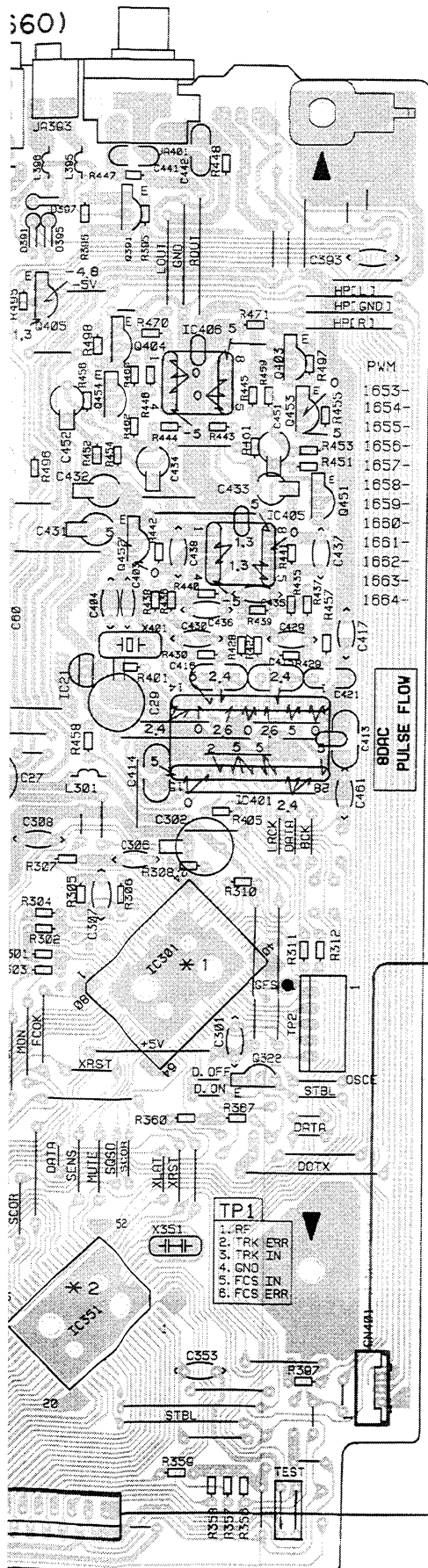

* 1
IC301 (CXD2500AQ)

Pin No.	Volts	Pin No.	Volts	Pin No.	Volts	Pin No.	Volts
1	5.0	21	0	41	NC	61	NC
2	NC	22	2.5	42	5.0	62	NC
3	5.0	23	5.0	43	NC	63	NC
4	2.8	24	2.5	44	NC	64	NC
5	NC	25	NC	45	NC	65	0
6	5.0	26	0	46	4.4	66	3.3 ~ 4.6
7	NC	27	2.5	47	0	67	5.0
8	NC	28	NC	48	0	68	0
9	0	29	0	49	0 ~ 0.3	69	2.1 ~ 3.0
10	0	30	NC	50	NC	70	5.0
11	NC	31	1.3 ~ 2.2	51	NC	71	5.0
12	0	32	2.5	52	0	72	5.0
13	NC	33	5.0	53	2.5	73	5.0
14	NC	34	2.5	54	NC	74	5.0
15	NC	35	NC	55	0	75	5.0
16	NC	36	NC	56	NC	76	0
17	0	37	NC	57	NC	77	5.0
18	2.5	38	NC	58	NC	78	5.0
19	2.4	39	NC	59	0	79	5.0
20	2.4	40	NC	60	NC	80	0

* 2
IC351 (PD4394A)

Pin No.	Volts	Pin No.	Volts	Pin No.	Volts	Pin No.	Volts
1	5.0	17	-9.1 ~ -9.3	33	5.0	49	5.0
2	NC	18	-26.0	34	3.3 ~ 4.7	50	5.0
3	-24 ~ -24.3	19	-5.0	35	5.0	51	0
4	-24 ~ -24.3	20	1.2	36	0	52	5.0
5	-24 ~ -24.3	21	1.1	37	5.0	53	5.0
6	-24 ~ -24.3	22	-9.0 ~ -12.0	38	5.0	54	0
7	-24 ~ -24.3	23	0.2 ~ 0.8	39	0	55	5.0
8	-24 ~ -24.3	24	0.6 ~ 1.1	40	0	56	2.5
9	-24 ~ -24.3	25	0	41	NC	57	2.5
10	-24 ~ -24.3	26	NC	42	NC	58	0
11	-24 ~ -24.3	27	0.2 ~ 0.4	43	5.0	59	0
12	5.0	28	-2.0 ~ -3.3	44	5.0	60	NC
13	5.0	29	-14.0 ~ -17.0	45	0	61	0
14	0	30	-11.5 ~ -17.3	46	5.0	62	0
15	NC	31	0	47	5.0	63	0
16	-23.8	32	5.0	48	2.1 ~ 3.0	64	0

HEADPHONE BOARD ASSEMBLY

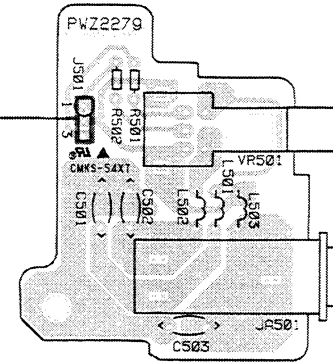

SWITCH BOARD ASSEMBLY

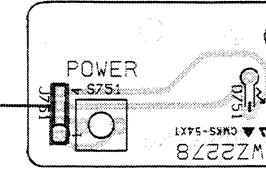

FUNCTION BOARD ASSEMBLY

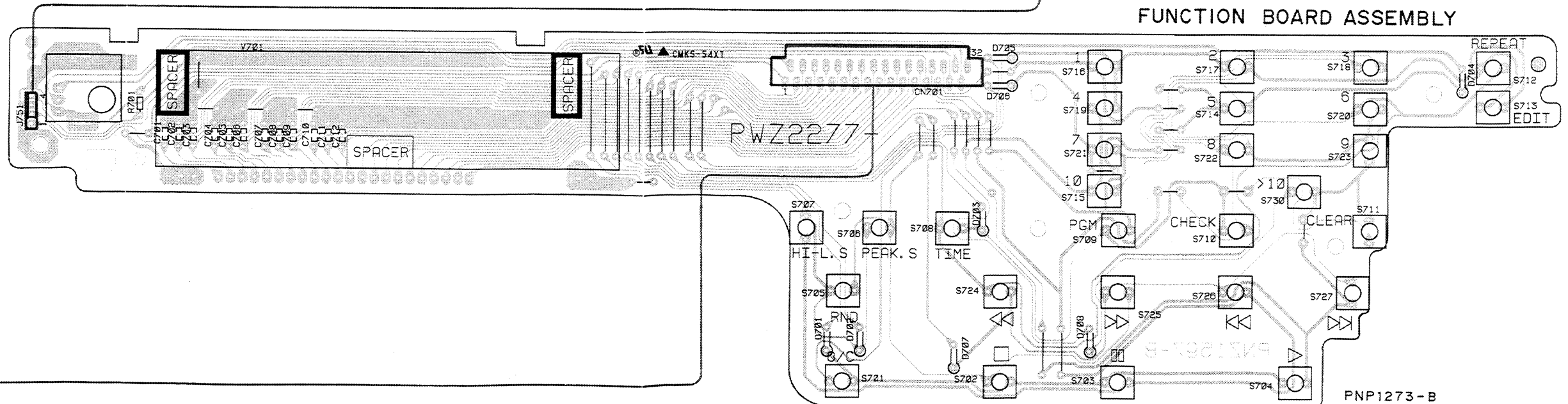

• View from soldering side

MOTHER BOARD ASSEMBLY (P/M1660)

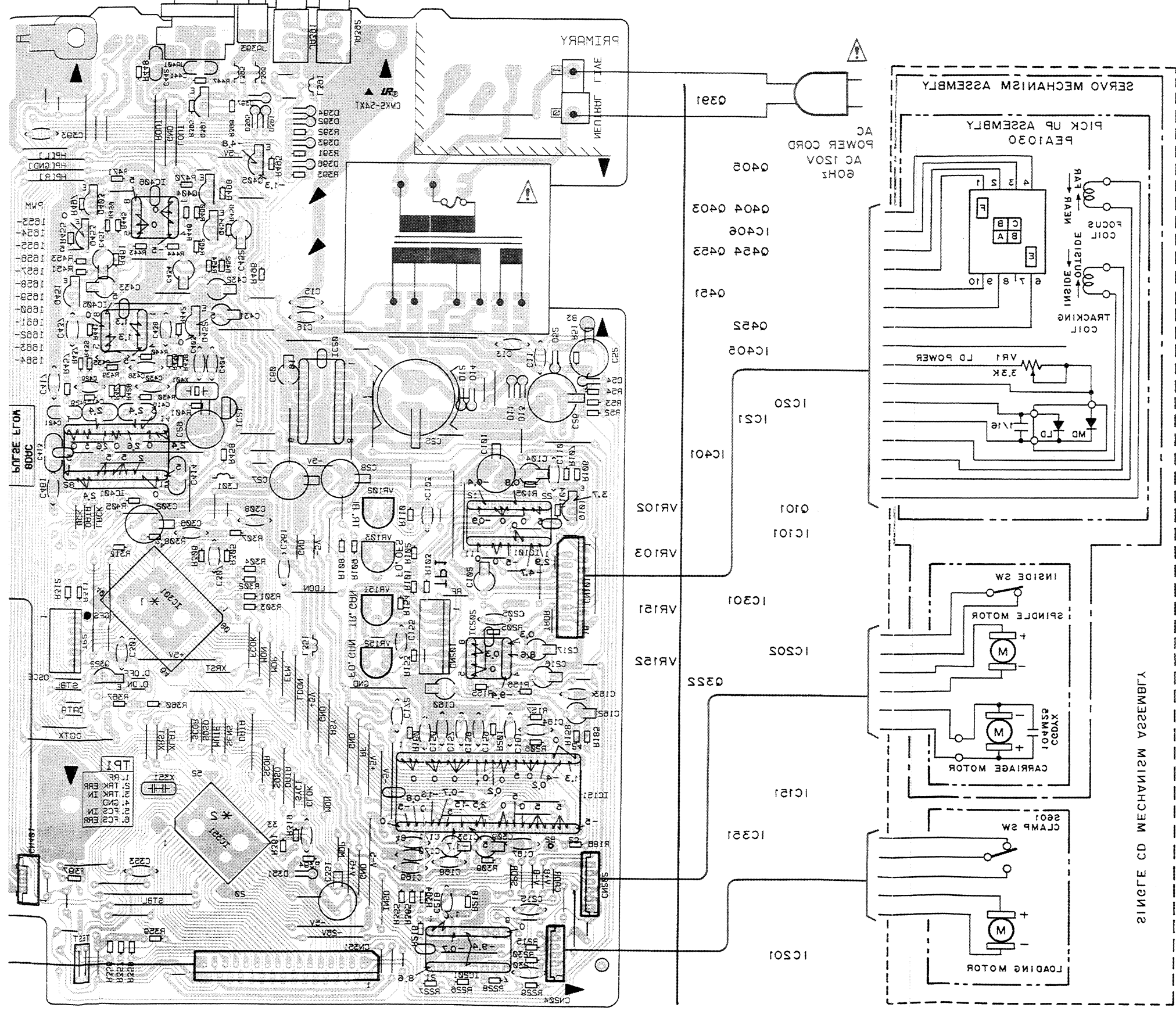

MOTHER BOARD ASSEMBLY (P/M1660)



3. PCB PARTS LIST

NOTES:

- Parts without part number cannot be supplied.
- Parts marked by "⊙" are not always kept in stock. Their delivery time may be longer than usual or they may be unavailable.
- The Δ mark found on some component parts indicates the importance of the safety factor of the part. Therefore, when replacing, be sure to use parts of identical designation.
- When ordering resistors, first convert resistance values into code form as shown in the following examples.

Ex.1 When there are 2 effective digits (any digit apart from 0), such as 560 ohm and 47k ohm (tolerance is shown by J=5%, and K=10%)

560 Ω → 56 × 10¹ → 561 RD1/4PS

5	6	1
---	---	---

 J
 47k Ω → 47 × 10³ → 473 RD1/4PS

4	7	3
---	---	---

 J
 0.5 Ω → 0R5 RN2H

0	R	5
---	---	---

 K
 1 Ω → 010 RS1P

0	1	0
---	---	---

 K

Ex.2 When there are 3 effective digits (such as in high precision metal film resistors).

5.62k Ω → 562 × 10¹ → 5621 RN1/4SR

5	6	2	1
---	---	---	---

 F

Mark	No.	Description	Part No.	Mark	No.	Description	Part No.
------	-----	-------------	----------	------	-----	-------------	----------

LIST OF ASSEMBLIES

⊙	MOTHER BOARD ASSEMBLY		PWM1660
⊙	SUB BOARD ASSEMBLY		PWX1210
	├ FUNCTION BOARD ASSEMBLY		
	├ SW PCB ASSEMBLY		
	└ HEADPHONE PCB ASSEMBLY		

⊙ MOTHER BOARD ASSEMBLY (PWM1660)

SEMICONDUCTORS

Δ	IC20 REGULATOR IC	TA2019P	
	IC21 REGULATOR IC	NJM2930L05	
	IC101 PRE AMP IC	CXA1471S	
	IC151 SERVO IC	CXA1372S	
Δ	IC201 POWER OP-AMP. IC	LA6520	
Δ	IC202 POWER OP-AMP. IC	LA6517	
	IC301 EFM DEMODULATION IC	CXD2500AQ	
	IC351 MICROCOMPUTER IC	PD4394A	
	IC401 D/A CONVERTER IC	PD2026A	
	IC405 OP-AMP IC	NJM4558D-D	
	IC406 OP-AMP IC	BA15218	
	Q101 TRANSISTOR	2SA854S	
	Q822 TRANSISTOR	DTC124ES	
	Q391 TRANSISTOR	2SC1740S	
	Q403, 404 TRANSISTOR	2SD2144S	
	Q405 TRANSISTOR	DTC124ES	
	Q451, 452 TRANSISTOR	DTA124ES	
	Q453, 454 TRANSISTOR	2SB1296	
Δ	D11-14 DIODE	11ES2	
Δ	D52 DIODE	11ES2	
	D54 ZENNER DIODE	MTZJ18B	
	D218 DIODE	1SS254	
	D351 DIODE	1SS254	
	D391-397 DIODE	1SS254	

COILS/TRANSFORMERS

L301 AXIAL INDUCTOR	LAU010K
L351 AXIAL INDUCTOR	LAU010K
L391 AXIAL INDUCTOR	LAU010K
L395, 396 AXIAL INDUCTOR	LAU010K

CAPACITORS

C11 CERAMIC CAPACITOR	CKCYF103Z50
C13 CERAMIC CAPACITOR	CKCYF103Z50
C15-17 CERAMIC CAPACITOR	CKCYF103Z50
C25 ELECTR. CAPACITOR	CEAS332M16
C26 ELECTR. CAPACITOR	CEAS222M16
C27 ELECTR. CAPACITOR	CEAS471M6R3
C28 ELECTR. CAPACITOR	CEAS101M10
C29 ELECTR. CAPACITOR	CEAS471M6R3
C52 ELECTR. CAPACITOR	CEAS101M35
C60 ELECTR. CAPACITOR	CEAS010M50
C101 ELECTR. CAPACITOR	CEAS471M6R3
C102 ELECTR. CAPACITOR	CEAS101M10
C103 CERAMIC CAPACITOR	CCCCH200J50
C104 ELECTR. CAPACITOR	CEAS101M10
C110 CERAMIC CAPACITOR	CKCYF103Z50
C153 ELECTR. CAPACITOR	CEAS101M10
C155 CERAMIC CAPACITOR	CKCYB182K50
C156 CERAMIC CAPACITOR	CGCYX333K25
C157 CERAMIC CAPACITOR	CGCYX103K25
C158, 159 CERAMIC CAPACITOR	CGCYX104K25
C160 ELECTR. CAPACITOR	CEAS4R7M50
C161 CERAMIC CAPACITOR	CGCYX104K25
C162 ELECTR. CAPACITOR	CEAS010M50
C163 CERAMIC CAPACITOR	CGCYX104K25
C164 CERAMIC CAPACITOR	CGCYX103K25
C167 CERAMIC CAPACITOR	CKCYF103Z50
C168 CERAMIC CAPACITOR	CGCYX333K25
C169 CERAMIC CAPACITOR	CGCYX103K25
C170 CERAMIC CAPACITOR	CKCYB332K50
C171, 172 CERAMIC CAPACITOR	CKCYB472K50
C205 CERAMIC CAPACITOR	CKCYF103Z50
C215 CERAMIC CAPACITOR	CGCYX103K25
C216, 217 ELECTR. CAPACITOR	CEAS330M16
C218 CERAMIC CAPACITOR	CKCYB272K50
C230 CERAMIC CAPACITOR	CGCYX104K25
C301 CERAMIC CAPACITOR	CGCYX104K25
C302 ELECTR. CAPACITOR	CEAS471M6R3

Mark No. Description Part No.

C306 CERAMIC CAPACITOR CKCYB152K50
 C307 CERAMIC CAPACITOR CGCYX473K25
 C308 CERAMIC CAPACITOR CGCYX103K25

 C309 ELECTR. CAPACITOR CEASR47M50
 C351 ELECTR. CAPACITOR CEAS471M6R3
 C353 CERAMIC CAPACITOR CKCYF103Z50
 C361 CERAMIC CAPACITOR CKCYF103Z50
 C393 CERAMIC CAPACITOR CCCSL101J50

 C403 CERAMIC CAPACITOR CCCCH120J50
 C404 CERAMIC CAPACITOR CCCCH220J50
 C413-416 FILM CAPACITOR PCL1032
 C417 CERAMIC CAPACITOR CKCYF103Z50
 C421 FILM CAPACITOR PCL1032

 C429, 430 CERAMIC CAPACITOR CCCCH390J50
 C431, 432 ELECTR. CAPACITOR CEAS330M16
 C433, 434 ELECTR. CAPACITOR CEAS220M25
 C435-438 CERAMIC CAPACITOR CCCCH390J50
 C441, 442 FILM CAPACITOR PCL1030

 C451, 452 ELECTR. CAPACITOR CEAS4R7M50
 C461 CERAMIC CAPACITOR CKCYF103Z50

RESISTORS

R51-54 CARBONFILM RESISTOR RD1/6PM□□□J
 R101-110 CARBONFILM RESISTOR RD1/6PM□□□J
 R153-158 CARBONFILM RESISTOR RD1/6PM□□□J
 R160 CARBONFILM RESISTOR RD1/6PM□□□J
 R185, 186 CARBONFILM RESISTOR RD1/6PM□□□J

 R201 CARBONFILM RESISTOR RD1/6PM□□□J
 R205, 206 CARBONFILM RESISTOR RD1/6PM□□□J
 R215, 216 CARBONFILM RESISTOR RD1/6PM□□□J
 R218 CARBONFILM RESISTOR RD1/6PM□□□J
 R226-230 CARBONFILM RESISTOR RD1/6PM□□□J

 R301-312 CARBONFILM RESISTOR RD1/6PM□□□J
 R319 CARBONFILM RESISTOR RD1/6PM□□□J
 R355-361 CARBONFILM RESISTOR RD1/6PM□□□J
 R364, 365 CARBONFILM RESISTOR RD1/6PM□□□J
 R367 CARBONFILM RESISTOR RD1/6PM□□□J

 R391-397 CARBONFILM RESISTOR RD1/6PM□□□J
 R401 CARBONFILM RESISTOR RD1/6PM□□□J
 R405 CARBONFILM RESISTOR RD1/6PM□□□J
 R427-430 CARBONFILM RESISTOR RD1/6PM□□□J
 R435-448 CARBONFILM RESISTOR RD1/6PM□□□J

 R451-462 CARBONFILM RESISTOR RD1/6PM□□□J
 R470, 471 CARBONFILM RESISTOR RD1/6PM□□□J
 R495-498 CARBONFILM RESISTOR RD1/6PM□□□J
 VR102 VR RCP1046
 VR103 VR RCP1044

 VR151, 152 VR RCP1046

OTHERS

CN101 CONNECTOR 52045-1610
 CN351 CONNECTOR HLEM32S-1
 JA391, 392 JACK/12V PKN1004
 JA393 JACK PKN1005
 JA401 JACK PKB1009

Mark No. Description Part No.

X351 CERAMIC RESONATOR VSS1014
 X401 XTAL RES (OSC) (16.9344MHz) PSS1008

FUNCTION BOARD ASSEMBLY

SEMICONDUCTORS

D701-708 DIODE 1SS254

SWITCHES

S701-727 SWITCH PSG1006
 S730 SWITCH PSG1006

CAPACITORS

C701-712 CERAMIC CAPACITOR CKPUYB181K50

RESISTORS

R701 CARBONFILM RESISTOR RD1/6PM□□□J

OTHERS

REMOTE SENSOR SBX1610-51
 CN701 CONNECTOR 9603S-32F
 V701 FL INDICATOR TUBE PEL1065

SW PCB ASSEMBLY

SEMICONDUCTORS

D751 LED PCX1019

SWITCHES

S751 SWITCH PSG1006

HEADPHONE PCB ASSEMBLY

COILS/TRANSFORMERS

L501-503 AXIAL INDUCTOR LAU010K

CAPACITORS

C501, 502 CERAMIC CAPACITOR CKCYF103Z50
 C503 CERAMIC CAPACITOR CKCYF473Z50

RESISTORS

VR501 VARIABLE RESISTOR PCS1003

OTHERS

JA501 JACK RKN1002

7. ADJUSTMENTS

9.1. Adjustment Methods

If a disc player is adjusted incorrectly or inadequately, it may malfunction or not work at all even though there is nothing at all wrong with the pickup or the circuitry. Adjust correctly following the adjustment procedure.

● Adjustment items/verification items and order

Step	Item	Test point	Adjustment location
1	Focus offset adjustment	TP1, Pin 6(FCS. ERR)	VR103(FCS. OFS)
2	Grating adjustment	TP1, Pin 2(TRK. ERR)	Grating adjustment slit
3	Tracking error balance adjustment	TP1, Pin 2(TRK. ERR)	VR102(TRK. BAL)
4	Pickup radial/tangential direction tilt adjustment	TP1, Pin 1(RF)	Radial tilt adjustment screw, Tangential tilt adjustment screw
5	RF level adjustment	TP1, Pin 1(RF)	VR1(RF level)
6	Focus servo loop gain adjustment	TP1, Pin 5(FCS. IN) TP1, Pin 6(FCS. ERR)	VR152(FCS. GAN)
7	Tracking servo loop gain adjustment	TP1, Pin 3(TRK. IN) TP1, Pin 2(TRK. ERR)	VR151(TRK. GAN)
8	Focus error signal verification	TP1, Pin 6(FCS. ERR)	—————

● Abbreviation table

FCS. ERR	:Focus Error
FCS. OFS	:Focus Offset
TRK. ERR	:Tracking Error
TRK. BAL	:Tracking Balance
FCS. GAN	:Focus Gain
TRK. GAN	:Tracking Gain
FCS. IN	:Focus In
TRK. IN	:Tracking In

● Measuring instruments and tools

1. Dual trace oscilloscope (10:1 probe)
2. Low-frequency oscillator
3. Test disc (YEDS-7)
4. 12- cm disc (with at least about 70 minutes recording)
5. Low-pass filter (39 k Ω + 0.001 μ F)
6. Resistor (100 k Ω)
7. Standard tools

● Test point and adjustment variable resistor positions

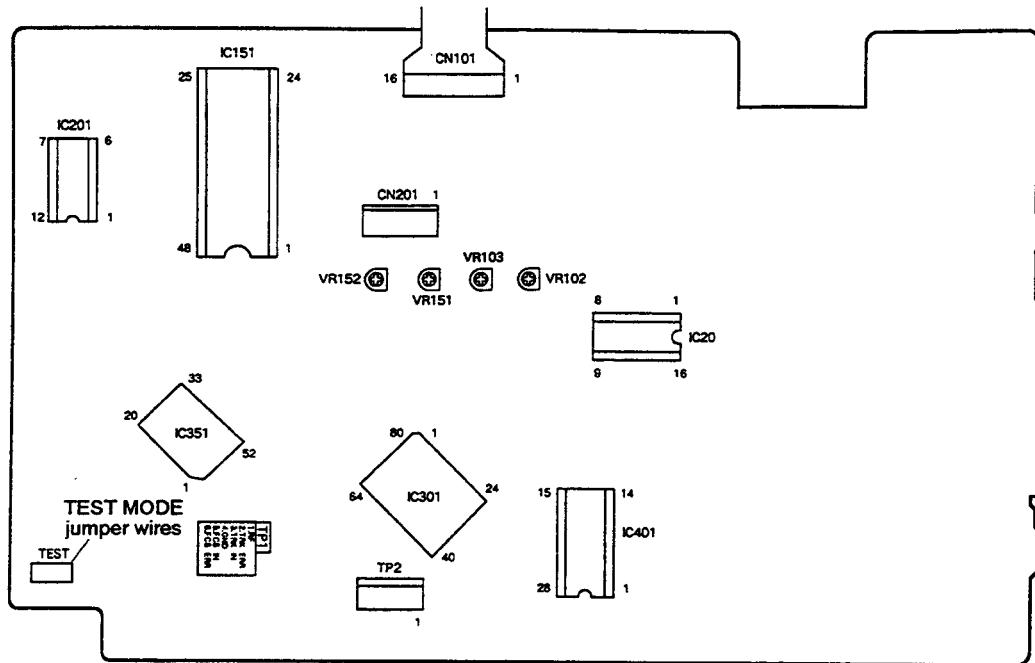

Figure 1 Adjustment Locations

● Notes

1. Use a 10:1 probe for the oscilloscope.
2. All the knob positions (settings) for the oscilloscope in the adjustment procedures are for when a 10:1 probe is used.

● Test mode

These models have a test mode so that the adjustments and checks required for service can be carried out easily. When these models are in test mode, the keys on the front panel work differently from normal. Adjustments and checks can be carried out by operating these keys with the correct procedure. For these models, all adjustments are carried out in test mode.

[Setting these models to test mode]

How to set this model into test mode.

1. Unplug the power cord from the AC socket.
2. Short the test mode jumper wires. (See Figure 1.)
3. Plug the power cord back into the AC socket.

When the test mode is set correctly, the display is different from what it usually is when the power is turned on. If the display is still the same as usual, test mode has not been set correctly, so repeat Steps 1 – 3.

[Release from test mode]

Here is the procedure for releasing the test mode:

1. Press the STOP key and stop all operations.
2. Unplug the power cord from the AC socket.

[Operations of the keys in test mode]

Code	Key name	Function in test mode	Explanation
	PROGRAM	Focus servo close	<p>The laser diode is lit up and the focus actuator is lowered, then raised slowly and the focus servo is closed at the point where the objective lens is focused on the disc.</p> <p>With the player in this state, if you lightly rotate the stopped disc by hand, you can hear the sound the focus servo.</p> <p>If you can hear this sound, the focus servo is operating correctly. If you press this key with no disc mounted, the laser diode lights up, the focus actuator is pulled down, then the actuator is raised and lowered twice and returned to its original position.</p>
▷	PLAY	Spindle servo ON	<p>Starts the spindle motor in the clockwise direction and when the disc rotation reaches the prescribed speed (about 500 rpm at the inner periphery), sets the spindle servo in a closed loop.</p> <p>Be careful. Pressing this key when there is no disc mounted makes the spindle motor run at the maximum speed.</p> <p>If the focus servo does not go correctly into a closed loop or the laser light shines on the mirror section at the outermost periphery of the disc, the same symptom is occurred.</p>
□□	PAUSE	Tracking servo close/open	<p>Pressing this key when the focus servo and spindle servo are operating correctly in closed loops puts the tracking servo into a closed loop, displays the track number being played back and the elapsed time on the front panel, and outputs the playback signal.</p> <p>If the elapsed time is not displayed or not counted correctly or the audio is not played back correctly, it may be that the laser is shining on the section with no sound recorded at the outer edge of the disc, that something is out of adjustment, or that there is some other problem.</p> <p>This key is a toggle key and open/close the tracking servo alternately. This key has no effect if no disc is mounted.</p>

Code	Key name	Function in test mode	Explanation
◀◀	MANUAL SEARCH REV	Carriage reverse (inwards)	Moves the pickup position toward the inner diameter of the disc. When this key is pressed with the tracking servo in a closed loop, the tracking servo automatically goes into an open loop. Since the motor does not automatically stop at the mechanical end point in test mode, be careful with this operation.
▶▶	MANUAL SEARCH FWD	Carriage forward (outwards)	Moves the pickup position toward the outer diameter of the disc. When this key is pressed with the tracking servo in a closed loop, the tracking servo automatically goes into an open loop. Since the motor does not automatically stop at the mechanical end point in test mode, be careful with this operation.
□	STOP	Stop	Switches off all the servos and initialized. The pickup remains where it was when this key was pressed.
△	OPEN/CLOSE	Disc tray open/close	Open/close the disc tray. This key is a toggle key and open/close tray alternately. Pressing this key when the disc is turning stops the disc, then opens the tray. This key operation does not affect the position of the pickup.

[How to play back a disc in test mode]

In test mode, since the servos operate independently, playing back a disc requires that you operate the keys in the correct order to close the servos.

Here is the key operation sequence for playing back a disc in test mode.

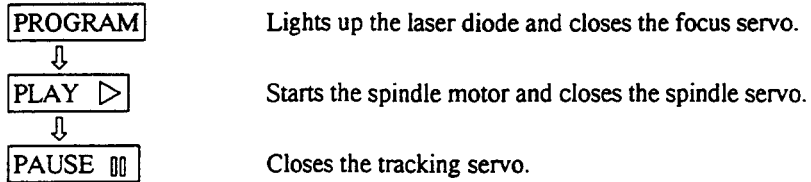

Wait at least 2-3 seconds between each of these operations.

1. Focus Offset Adjustment

<ul style="list-style-type: none"> ● Objective ● Symptom when out of adjustment 	Sets the DC offset for the focus error amp. The model does not focus in and the RF signal is dirty.		
<ul style="list-style-type: none"> ● Measurement instrument connections 	Connect the oscilloscope to TP1, Pin 6 (FCS. ERR) [Settings] 5 mV/division 10 ms/division DC mode	<ul style="list-style-type: none"> ● Player state ● Adjustment location ● Disc 	Test mode, stopped (just the Power switch on) VR103 (FCS. OFS) None needed

[Procedure]

Adjust VR103 (FCS. OFS) so that the DC voltage at TP1, Pin 6 (FCS. ERR) is -150 ± 50 mV.

2. Grating Adjustment

<ul style="list-style-type: none"> ● Objective 	To align the tracking error generation laser beam spots to the optimum angle on the track.		
<ul style="list-style-type: none"> ● Symptom when out of adjustment 	Play does not start, track search is impossible, tracks are skipped.		
<ul style="list-style-type: none"> ● Measurement instrument connections 	Connect the oscilloscope to TP1, Pin 2 (TRK. ERR) via a low pass filter. (See Figure 2)	<ul style="list-style-type: none"> ● Player state 	Test mode, focus and spindle servos closed and tracking servo open
	[Settings] 50 mV/division 5 ms/division DC mode	<ul style="list-style-type: none"> ● Adjustment location 	Pickup grating adjustment slit
		<ul style="list-style-type: none"> ● Disc 	12-cm disc. (YEDS-7 can not be used.)

[Procedure]

1. Move the pickup to the outer edge of the disc with the MANUAL SEARCH FWD $\triangleright\triangleright$ or REV $\triangleleft\triangleleft$ key.
2. Press the PROGRAM key, then the PLAY \triangleright key in that order to close the focus servo then the spindle servo.
3. Insert an ordinary screwdriver into the grating adjustment slit and adjust the grating to find the null point. For more details, see the next page.
4. If you slowly turn the screwdriver counterclockwise from the null point, the amplitude of the wave gradually increases, then if you continue turning the screwdriver, the amplitude of the wave becomes smaller again. Turn the screwdriver counterclockwise from the null point and set the grating to the first point where the wave amplitude reaches its maximum.

Reference : Figure 3 shows the relation between the angle of the tracking beam with the track and the waveform.

Note : The amplitude of the tracking error signal is about 3 V_{p-p} (when a 39 kΩ + 0.001 μF low pass filter is used). If this amplitude is extremely small (2 V_{p-p} or less), the objective lens or the pickup malfunction may be the cause. If the difference between the amplitude of the error signal at the innermost edge and outermost edge of the disc is more than 10%, the grating is not adjusted to the optimum point, so adjust it again.

5. Return the pickup to more or less midway across the disc with the MANUAL SEARCH REV $\triangleleft\triangleleft$ key, press the PAUSE $\square\square$ key and double check that the track number and elapsed time are displayed on the front panel. If they are not displayed at this time or the elapsed time changes irregularly, double check the null point and adjust the grating again.

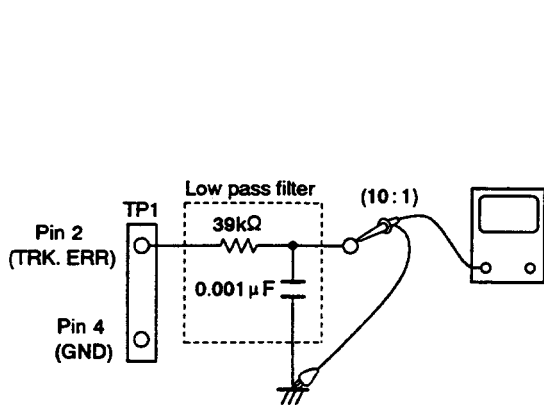
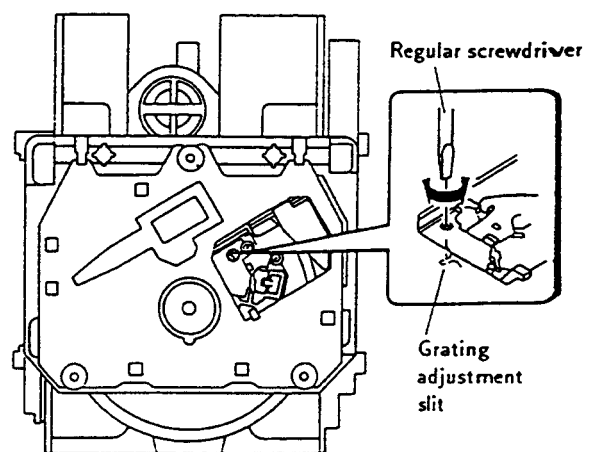

Figure 2



Adjustment locations

[How to find the null point]

When you insert the regular screwdriver into the slit for the grating adjustment and change the grating angle, the amplitude of the tracking error signal at TP1, Pin 2 changes. Within the range for the grating, there are five or six locations where the amplitude of the wave reaches a minimum. Of these five or six locations, there is only one at which the envelope of the waveform is smooth. This location is where the three laser beams divided by the grating are all right above the same track. (See Figure 3.)

This point is called the null point. When adjusting the grating, this null point is found and used as the reference position.

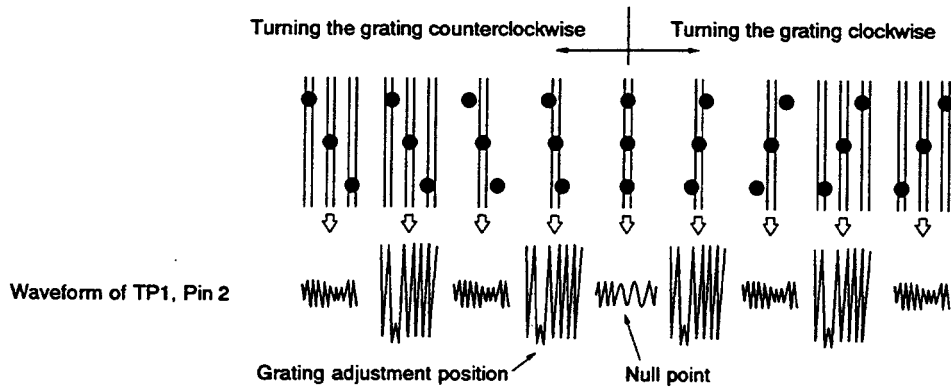
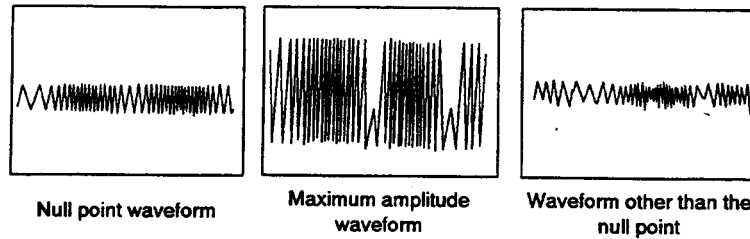

Figure 3



3. Tracking Error Balance Adjustment

<ul style="list-style-type: none"> ● Objective ● Symptom when out of adjustment 	To correct for the variation in the sensitivity of the tracking photodiode. Play does not start or track search is impossible.		
<ul style="list-style-type: none"> ● Measurement instrument connections 	Connect the oscilloscope to TP1, Pin 2 (TRK. ERR). This connection may be via a low pass filter. [Settings] 50 mV/division 5 ms/division DC mode	<ul style="list-style-type: none"> ● Player state ● Adjustment location ● Disc 	Test mode, focus and spindle servos closed and tracking servo open VR102 (TRK. BAL) YEDS-7

[Procedure]

1. Move the pickup to midway across the disc (R=35 mm) with the MANUAL SEARCH FWD $\triangleright\triangleright$ or REV $\triangleleft\triangleleft$ key.
2. Press the PROGRAM key, then the PLAY \triangleright key in that order to close the focus servo then the spindle servo.
3. Line up the bright line (ground) at the center of the oscilloscope screen and put the oscilloscope into DC mode.
4. Adjust VR102 (TRK. BAL) so that the positive amplitude and negative amplitude of the tracking error signal at TP1, Pin 2 (TRK. ERR) are the same (in other words, so that there is no DC component).

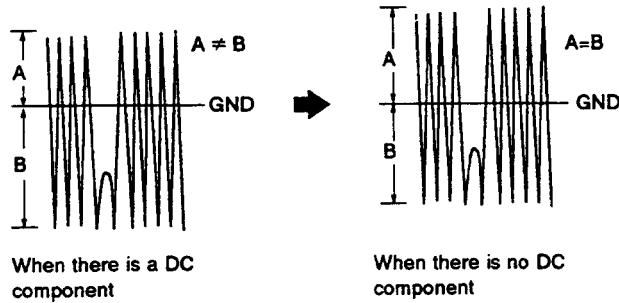

4. Pickup Radial/Tangential Tilt Adjustment

<ul style="list-style-type: none"> ● Objective 	To adjust the angle of the pickup relative to the disc so that the laser beams are shone straight down into the disc for the best read out of the RF signals.		
<ul style="list-style-type: none"> ● Symptom when out of adjustment 	Sound broken; some discs can be played but not others.		
<ul style="list-style-type: none"> ● Measurement instrument connections 	Connect the oscilloscope to TP1, Pin 1 (RF). [Settings] 20 mV/division 200 ns/division AC mode	<ul style="list-style-type: none"> ● Player state ● Adjustment location ● Disc 	Test mode, play Pickup radial tilt adjustment screw and tangential tilt adjustment screw 12- cm disc. (YEDS-7 can not be used.)

[Procedure]

1. Press the MANUAL SEARCH FWD >> or REV << key so that the radial / tangential tilt screws can be adjusted. Press the PROGRAM key, the PLAY > key, then the PAUSE || key in that order to close the focus servo then the spindle servo and put the player into play mode.
2. First, adjust the radial tilt adjustment screw with an Philips screwdriver so that the eye pattern (the diamond shape at the center of the RF signal) can be seen the most clearly.
3. Next, adjust the tangential tilt adjustment screw with an Philips screwdriver wrench so that the eye pattern (the diamond shape at the center of the RF signal) can be seen the most clearly (Figure 5).
4. Adjust the radial tilt adjustment screw and the tangential tilt adjustment screw again so that the eye pattern can be seen the most clearly. As necessary, adjust the two screws alternately so that the eye pattern can be seen the most clearly.

Note:Radial and tangential mean the directions relative to the disc shown in Figure 4.

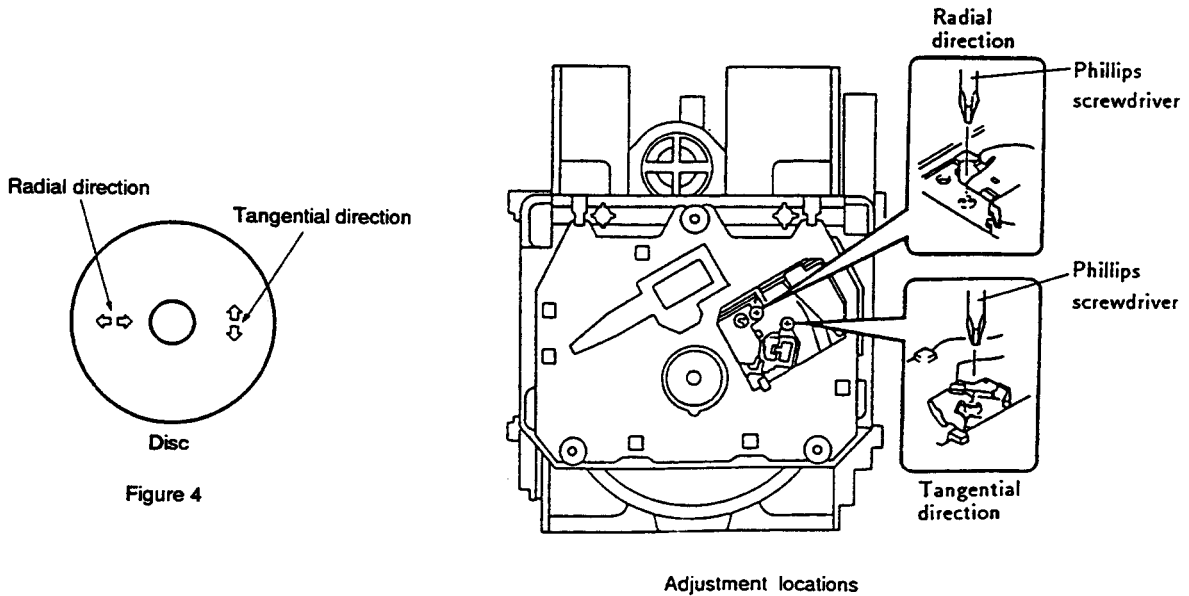

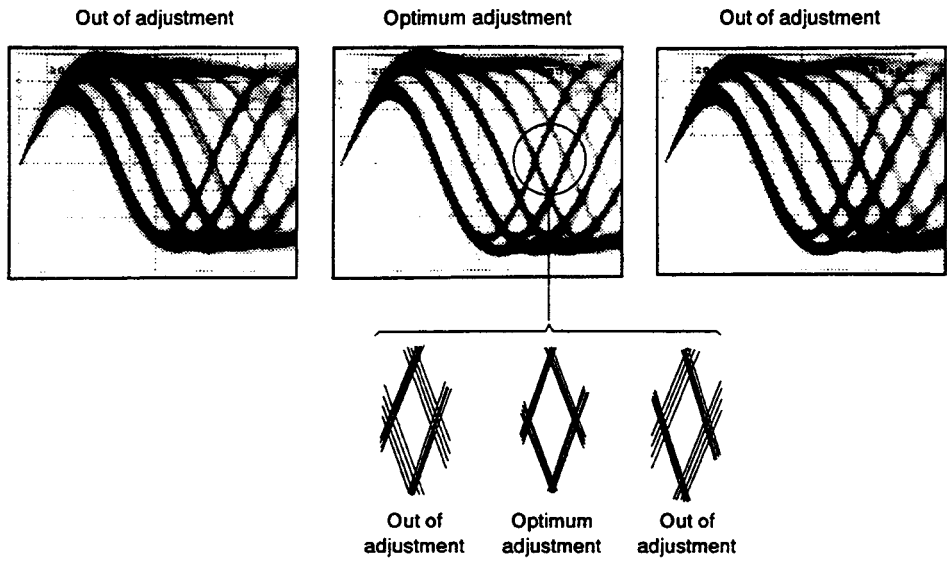

Figure 5 Eye pattern

5. RF Level Adjustment

● Objective	To optimize the playback RF signal amplitude		
● Symptom when out of adjustment	No play or no search		
● Measurement instrument connections	Connect the oscilloscope to TP1, Pin 1 (RF).	● Player state	Test mode, play
	[Settings] 50 mV/division 10 ms/division AC mode	● Adjustment location	VR1 (laser power)
		● Disc	YEDS-7

[Procedure]

1. Move the pickup to midway across the disc (R=35 mm) with the MANUAL SEARCH FWD ▷▷ or REV ◁◁ key, then press the PROGRAM key, then the PLAY ▷ key in that order to close the respective servos and put the player into play mode.
2. Adjust VR1 (laser power) so that the RF signal amplitude is $1.2 V_{p-p} \pm 0.1 V$.

6. Focus Servo Loop Gain Adjustment

● Objective	To optimize the focus servo loop gain.		
● Symptom when out of adjustment	Playback does not start or focus actuator noisy.		
● Measurement instrument connections	See figure 6. [Settings] CH1 CH2 20 mV/division 5 mV/division X - Y mode	● Player state ● Adjustment location ● Disc	Test mode, play VR152 (FCS. GAN) YEDS-7

[Procedure]

1. Set the AF generator output to 1.2 kHz and 1 Vp-p.
2. Press the MANUAL SEARCH FWD >> or REV << key to move the pickup to halfway across the disc (R=35 mm), then press the PROGRAM key, the PLAY > key, then the PAUSE ||| key in that order to close the corresponding servos and put the player into play mode.
3. Adjust VR152 (FCS. GAN) so that the Lissajous waveform is symmetrical about the X axis and the Y axis.

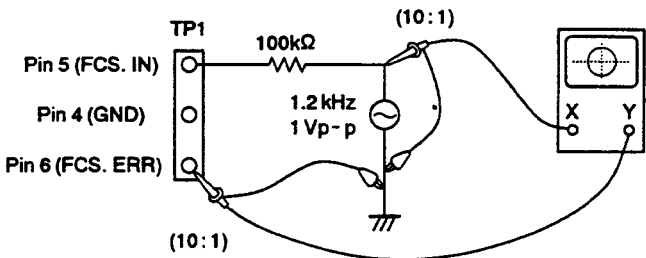
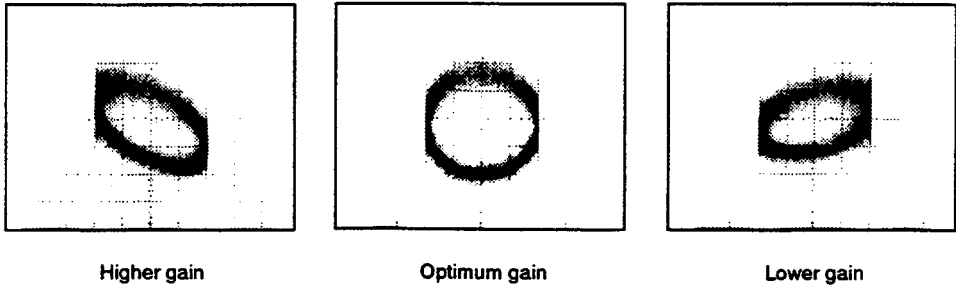

Figure 6

Focus Gain Adjustment



Higher gain

Optimum gain

Lower gain

7. Tracking Servo Loop Gain Adjustment

● Objective	To optimize the tracking servo loop gain.		
● Symptom when out of adjustment	Playback does not start, during searches the actuator is noisy, or tracks are skipped.		
● Measurement instrument connections	See Figure 7.	● Player state	Test mode, play
	[Settings] CH1 CH2 50 mV/division 5 mV/division X-Y mode	● Adjustment location ● Disc	VR151 (TRK. GAN) YEDS-7

[Procedure]

1. Set the AF generator output to 1.2 kHz and 2 Vp-p.
2. Press the MANUAL SEARCH FWD >> or REV << key to move the pickup to halfway across the disc (R=35 mm), then press the PROGRAM key, the PLAY > key, then the PAUSE || key in that order to close the corresponding servos and put the player into play mode.
3. Adjust VR151 (TRK. GAN) so that the Lissajous waveform is symmetrical about the X axis and the Y axis.

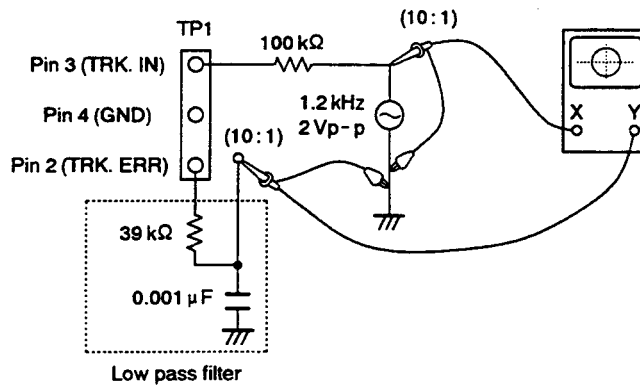
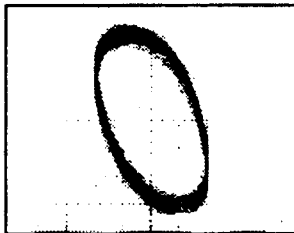
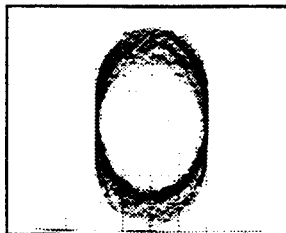

Figure 7

Tracking Gain Adjustment



Higher gain



Optimum gain

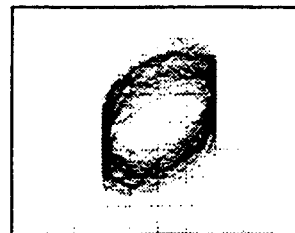

Lower gain

8. Focus Error Signal (Focus S Curve) Verification

<ul style="list-style-type: none"> ● Objective ● Symptom when out of adjustment 	To judge whether the pickup is ok or not by observing the focus error signal. The pickup is judged from the amplitude of the tracking error signal (as discussed in the section on adjusting the tracking error balance) and the waveform for the focus error signal.		
<ul style="list-style-type: none"> ● Measurement instrument connections 	Connect the oscilloscope to TP1, Pin 6 (FCS. ERR). [Settings] 100 mV/division 5 ms/division DC mode	<ul style="list-style-type: none"> ● Player state ● Adjustment location ● Disc 	Test mode, stop None YEDS-7

[Procedure]

1. Connect TP1 Pin 5 to ground.
2. Mount the disc.
3. While watching the oscilloscope screen, press the PROGRAM key and observe the waveform in Figure 8 for a moment. Verify that the amplitude is at least 2.5 Vp-p and that the positive and negative amplitude are about equal. Since the waveform is only output for a moment when the PROGRAM key is pressed, press this key over and over until you have checked the waveform.

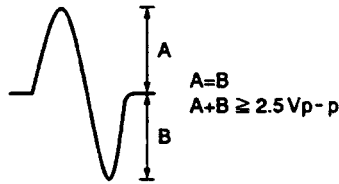

Figure 8

[Judging the pickup]

Do not judge the pickup until all the adjustments have been made correctly. In the following cases, there may be something wrong with the pickup.

1. The tracking error signal amplitude is extremely small (less than 2 Vp-p).
2. The focus error signal amplitude is extremely small (less than 2.5 Vp-p).
3. The positive and negative amplitudes of the focus error signal are extremely asymmetrical (2 : 1 ratio or more).
4. The RF signal is too small (less than 0.8 Vp-p) and even if VR1 (laser power) is adjusted, the RF signal can not be brought up to the standard level.

8. FOR PD-S501/KC, KUXJS AND KCXJS TYPES

NOTES:

- Parts without part number cannot be supplied.
- The Δ mark found on some component parts indicates the importance of the safety factor of the part. Therefore, when replacing, be sure to use parts of identical designation.
- Parts marked by "⊙" are not always kept in stock. Their delivery time may be longer than usual or they may be unavailable.

PD-S501/KC, KUXJS, KCXJS and PD-S501/KU have the same construction except for the following:

Mark	Symbol & Description	Part No.				Remarks
		PD-S501/ KU type	PD-S501/ KC type	PD-S501/ KUXJS type	PD-S501/ KCXJS type	
	CD packing case Operating instructions (English) Operating instructions (English/German)	PHG1751 PRB1160	PHG1823 PRE1154	PHG1766 PRB1160	PHG1826 PRE1154	

9. PANEL FACILITIES

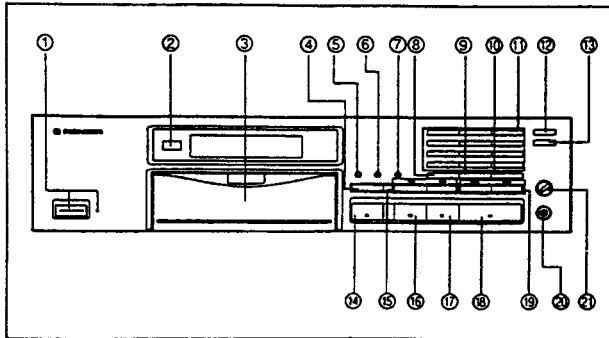

FRONT PANEL

- ① POWER STANDBY/ON switch and STANDBY indicator
- ② Remote sensor
Receives the signal from the remote control unit.
- ③ Disc tray
- ④ RANDOM PLAY button
- ⑤ HI-LITE SCAN button
- ⑥ PEAK SEARCH button
- ⑦ TIME button
- ⑧ PROGRAM button
- ⑨ CHECK button
- ⑩ CLEAR button
- ⑪ Track number/Digit buttons (1 - 10, >10)
- ⑫ REPEAT button
- ⑬ COMPU/AUTO EDIT button
- ⑭ OPEN/CLOSE button (▲)
- ⑮ Manual search buttons (◀◀/▶▶)
- ⑯ Stop button (■)
- ⑰ Pause button (||)
- ⑱ Play button (▶)
- ⑲ Track search buttons (◀◀/▶▶)
- ⑳ Headphones jack (PHONES)
- ㉑ Headphones volume control (PHONES LEVEL)

10. SPECIFICATIONS

1. General

Type	Compact disc digital audio system
Power requirements	
European model	AC 220 - 240 V, 50/60 Hz
U.K. and Australian models	AC 220 - 240 V, 60 Hz
U.S. and Canadian models	AC 120 V, 60Hz
Other models	AC 110 - 127/220 - 240 V (Switchable), 50/60 Hz
Power consumption	
U.S. and Canadian models	14 W
Other models	16 W
Operating temperature	+5°C - +35°C +41°F - +95°F
Weight	3.8 kg (8 lb, 6 oz)
External dimensions	420(W) X 276(D) X 110(H) mm 16-9/16(W) X 10-7/8(D) X 4-5/16(H) in

2. Audio section

Frequency response	2 Hz - 20 kHz
S/N ratio	104 dB or more (EIAJ)
Dynamic range	96 dB or more (EIAJ)
Harmonic distortion	0.003% or less (EIAJ)
Output voltage	2.0 V
Wow and flutter	Limit of measurement (±0.001% W.PEAK) or less (EIAJ)
Channels	2-channel (stereo)

3. Output terminal

Audio line output jacks
Control input/output jacks (available with U.S. and Canadian models:
Not available with models for military zones (multi-voltage types))
CD-DECK SYNCHRO jack
Headphone jack (with volume control)

4. Accessories

● Remote control unit	1
● Size AAA/R03/dry batteries	2
● Control cord (provided with U.S. and Canadian models: Not available with models for military zones (multi-voltage types))	1
● Output cable	1
● Operating instructions	1

NOTE:

Specifications and design subject to possible modification without notice, due to improvements.