

STEREO TURNTABLE
PL-112D
KCT, KUT

<ART-164-0>

Service Manual



 **PIONEER®**

CONTENTS

1.	SPECIFICATIONS	4
2.	PANEL FACILITIES	5
3.	PARTS LOCATIONS	
3.1	Top View	7
3.2	Bottom View	9
4.	EXPLODED VIEW	
4.1	Main Panel	11
4.2	Tone Arm	13
4.3	Cabinet	14
4.4	Packing	15
5.	NOMENCLATURE OF SCREWS, WASHERS AND NUTS	16

1. SPECIFICATIONS

MOTOR AND TURNTABLE

Motor	4-pole synchronous
Turntable drive	Belt-driven
Speed	Two speeds: 33-1/3rpm, 45rpm
Wow and flutter	0.07% (WRMS) or less
S/N	50dB (JIS) or more (with Pioneer cartridge model PC-135)
Turntable platter	30cm diam. aluminum alloy
Moment of inertia	135kg-cm ² (including rubber mat)

TONARM

Tonearm type	Static-balance, S-shaped, pipe arm
Effective arm length	221mm
Tracking error	+3° ~ -1°
Overhang	15.5mm
Usable cartridge weight	4g (min.) ~ 10g (Max.) (For cartridge weighs over 7.0g, attach the sub weight)

SUBFUNCTIONS

- Anti-skating force control
- Plug-in type headshell
- Oil-damped arm elevator
- Hinges (Free-adjustable)
- Lateral balancer

MISCELLANEOUS

Power requirements	AC 120V, 60Hz
Power consumption	10W
Dimensions	440(W) x 362(D) x 159(H)mm 17-5/16(W) x 14-1/4(D) x 6-1/4(H)in.
Weight	6kg, 13lb 2 oz.

ACCESSORIES

Headshell	1
Accessory oil	1
Overhang gauge	1
45rpm adaptor	1
Screwdriver	1
Sub weight	1
Cartridge mounting screws	6
Cartridge mounting nuts	2
Cartridge mounting washers	2
Operating instructions	1

NOTE:

Specifications and design subject to possible modification without notice due to improvements.

2. PANEL FACILITIES

HEADSHELL STAND

A spare headshell can be stored in this stand. Align the headshell pin with the stand groove and insert. Observe that the headshell length is not greater than the height of the dust cover. This stand can also be used for storing the 45rpm adaptor.

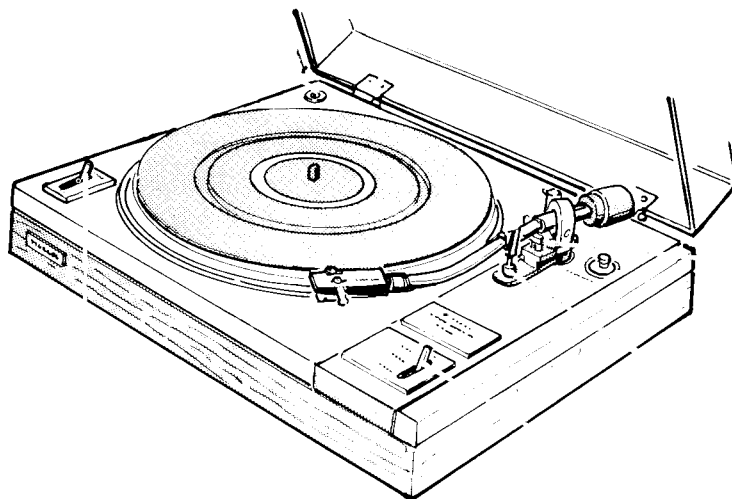
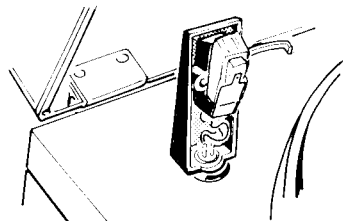

SPEED SELECT LEVER

Either of the two speeds, 33-1/3rpm or 45rpm, can be selected by this lever. Change the lever position only while the turntable is rotating.

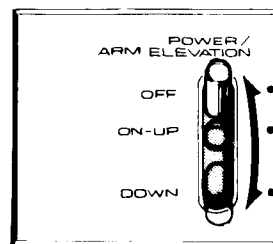
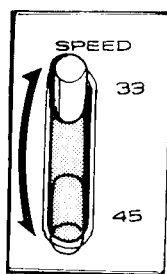

45 RPM ADAPTOR

A 45rpm record adaptor is supplied in the accessory box, which permits 45rpm EP records with large center holes to be played.

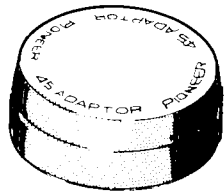

FUNCTION LEVER

This lever incorporates power switch and arm elevation functions.

- OFF AC power is cut off.
- ON-UP Power is turned ON. When set from DOWN to this position, the tonearm is raised.
- DOWN Tonearm is gently lowered.

OPERATION

1. Remove the stylus cover.
2. Set the function lever to ON-UP.
(The turntable platter will begin to rotate.)
3. Set the SPEED select lever to the correct speed according to the record to be played.
4. Disengage arm clamp and gently position the tonearm over the desired portion of the record.
5. Set the function lever to DOWN.
Stylus will be gently lowered onto the record.
6. Adjust the volume and tone controls of the stereo amplifier as desired.
7. At the end of the record, or to interrupt the record, set the function lever to ON-UP.
8. Return tonearm to arm rest and engage clamp.
9. Set the function lever to OFF.
(Power will be cut off.)
10. It is advisable to replace the stylus cover for protection whenever the turntable is not in use.

ARM ELEVATION

Arm elevation may require adjustment according to cartridge height. If necessary use the accessory screwdriver to loosen the setscrew and adjust (see figure).

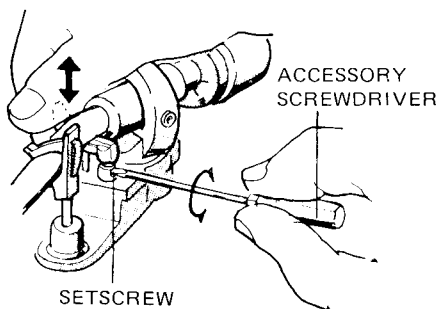

To take Full Advantage of the Function Lever (Arm Elevation)

The function lever (ARM ELEVATION) is particularly convenient when you wish to choose a particular track from an LP record.

- If you move the tonearm while the function lever is set to DOWN, take care not to damage the stylus point.

OPERATING PRECAUTIONS

- Keep stylus and records clean. Use a stylus brush to clean the stylus and a good quality record cleaner to clean the records each time before and after playing.
- Avoid exerting unnecessary force on the tonearm. When changing headshells, set the tonearm in the arm rest and engage the clamp.
- Take care not to impart vibration to the turntable while a record is playing. Record and stylus can be damaged.
- Never touch the SPEED select lever if the turntable is stationary. The speed can be changed only while the turntable is rotating.
- Never obstruct the turntable while it is rotating. This may cause damage.
- Avoid placing more than 2 records on the turntable platter while playing record.

ARM REST

The arm rest supports the tonearm, which should be secured by the arm clamp when not in use. Before raising the tonearm, be sure to release the clamp.

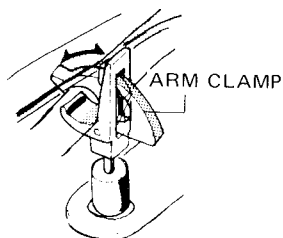

3. PARTS LOCATIONS

3.1 TOP VIEW

AC power cord
KDG-011

Head shell stand
PNW-073

Capstan
PLA-040

Angle
PNB-142

Center shaft assembly
PXA-134

Speed selector panel
PAN-019



CAUTION
TO PREVENT AN ELECTRICAL SHOCK
DO NOT REMOVE THE COVER THERE
ARE NO USER SERVICEABLE PARTS
INSIDE REFER ALL SERVICING TO
QUALIFIED SERVICE PERSONNEL
AAX 001 0

Head s
PXA-5

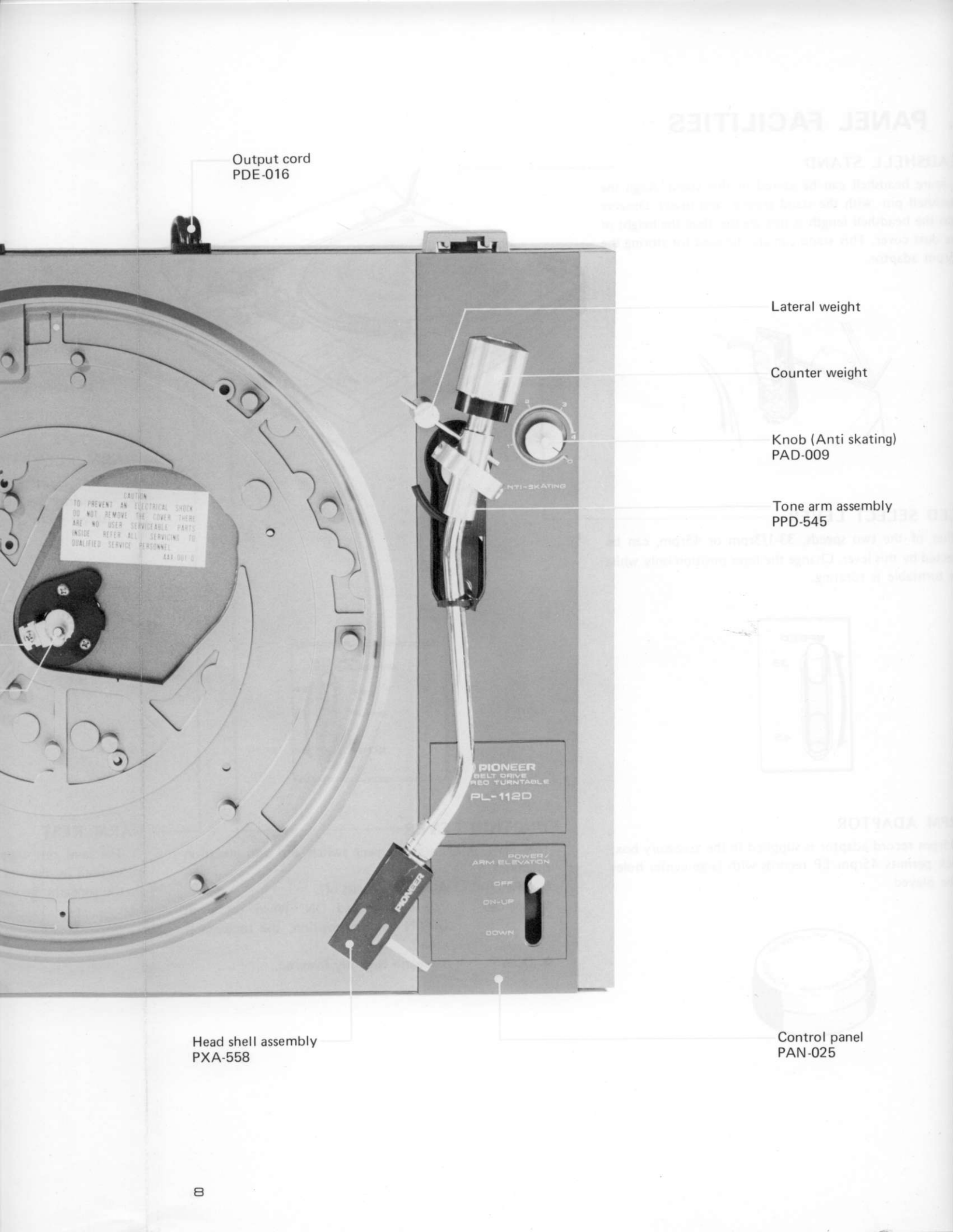

Output cord
PDE-016

Lateral weight

Counter weight

Knob (Anti skating)
PAD-009

Tone arm assembly
PPD-545

CAUTION
TO PREVENT AN ELECTRICAL SHOCK
DO NOT REMOVE THE COVER THERE
ARE NO USER SERVICEABLE PARTS
INSIDE REFER ALL SERVICING TO
QUALIFIED SERVICE PERSONNEL
883-001-0

PIONEER
BELT DRIVE
REG TURNTABLE
PL-112D

POWER /
ARM ELEVATION

OFF

ON-UP

DOWN

Head shell assembly
PXA-558

Control panel
PAN-025

3.2 BOTTOM VIEW

Rubber grommets (A)
PEB-010

Microswitch
KSF-023

Sub panel

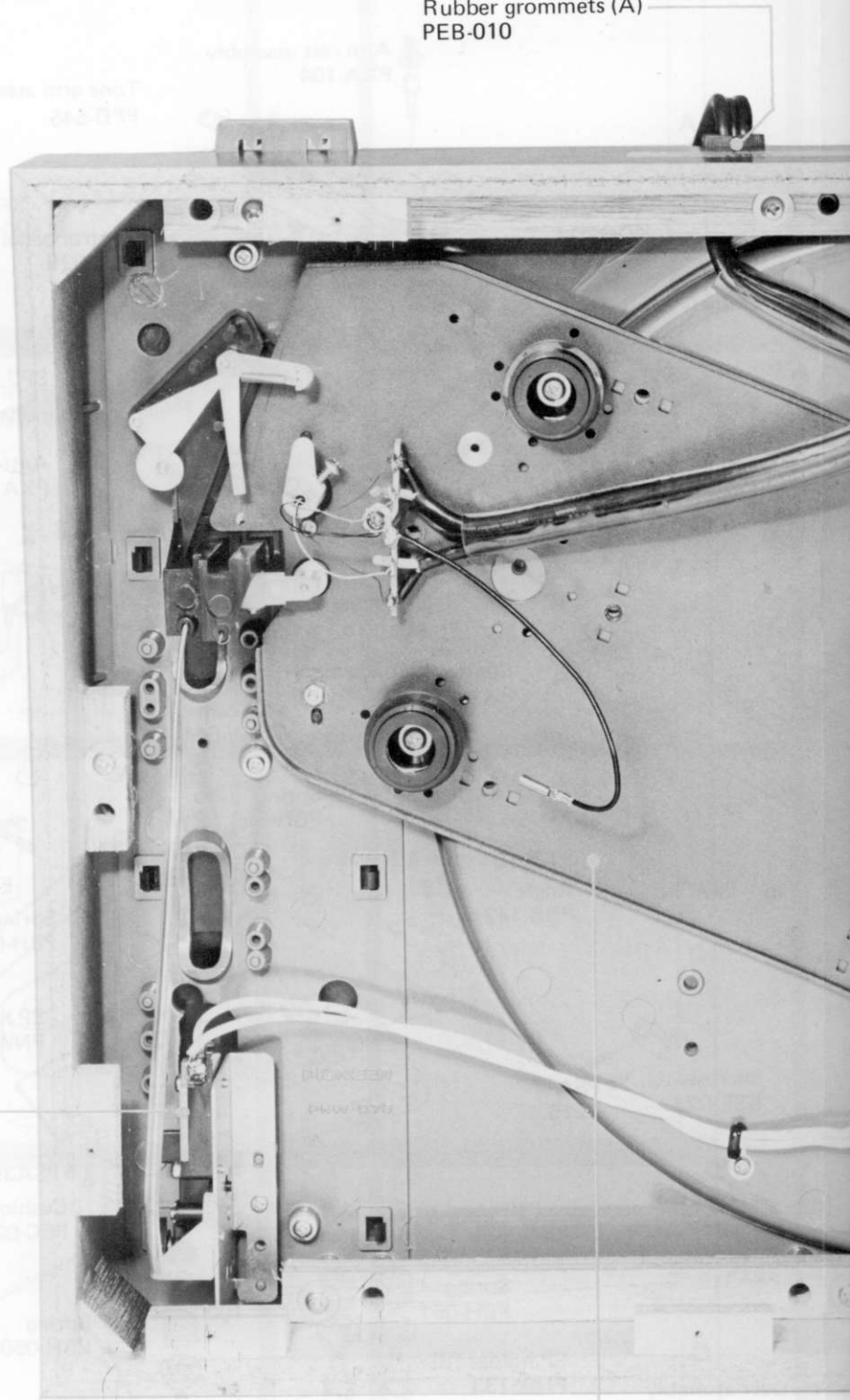

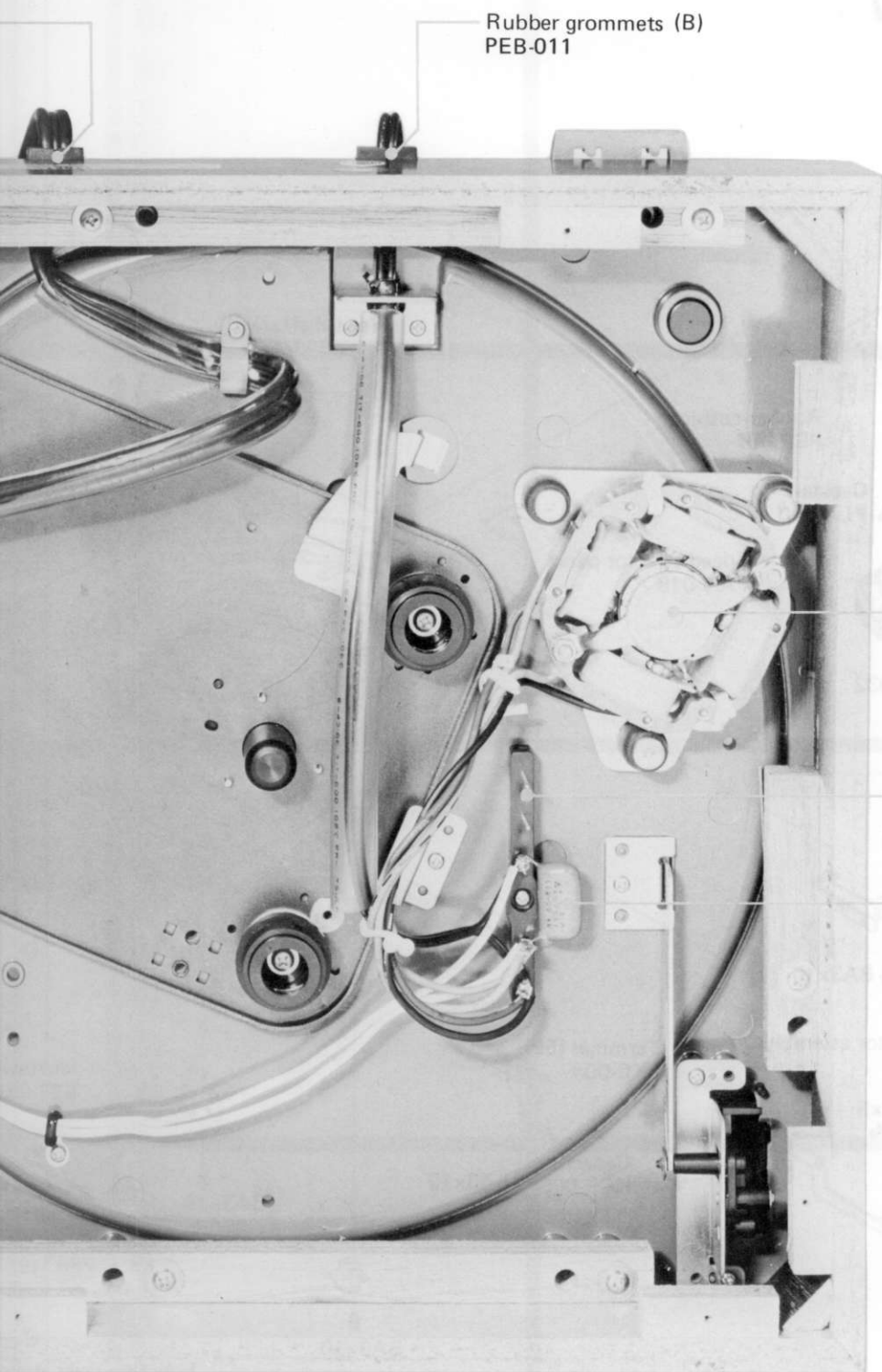

Rubber grommets (B)
PEB-011

Motor
PXM-022

Terminal
PKC-004

Capacitor
KCE-005

4. EXPLODED VIEW

4.1 MAIN PANEL

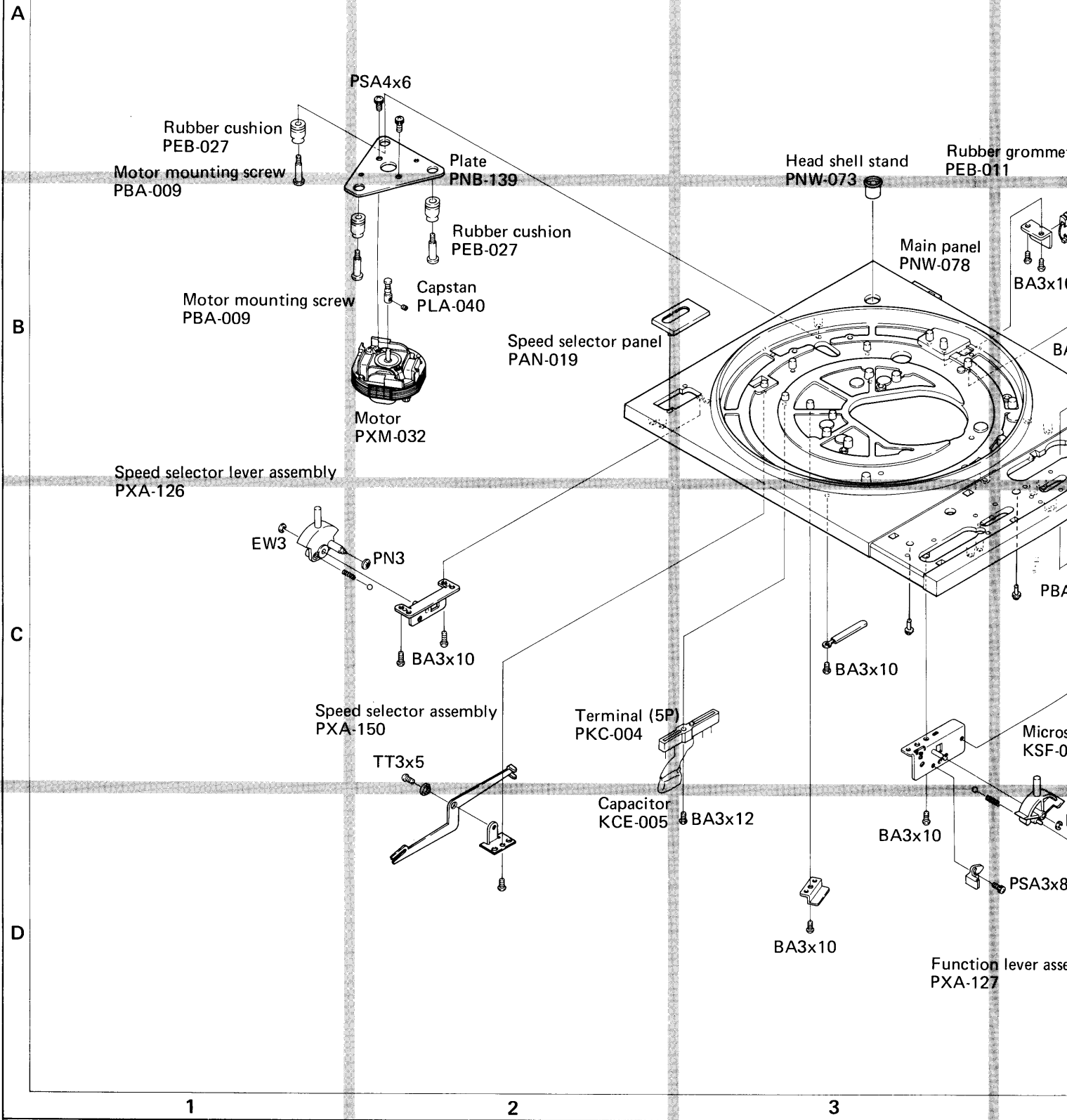

4.2 TONE ARM

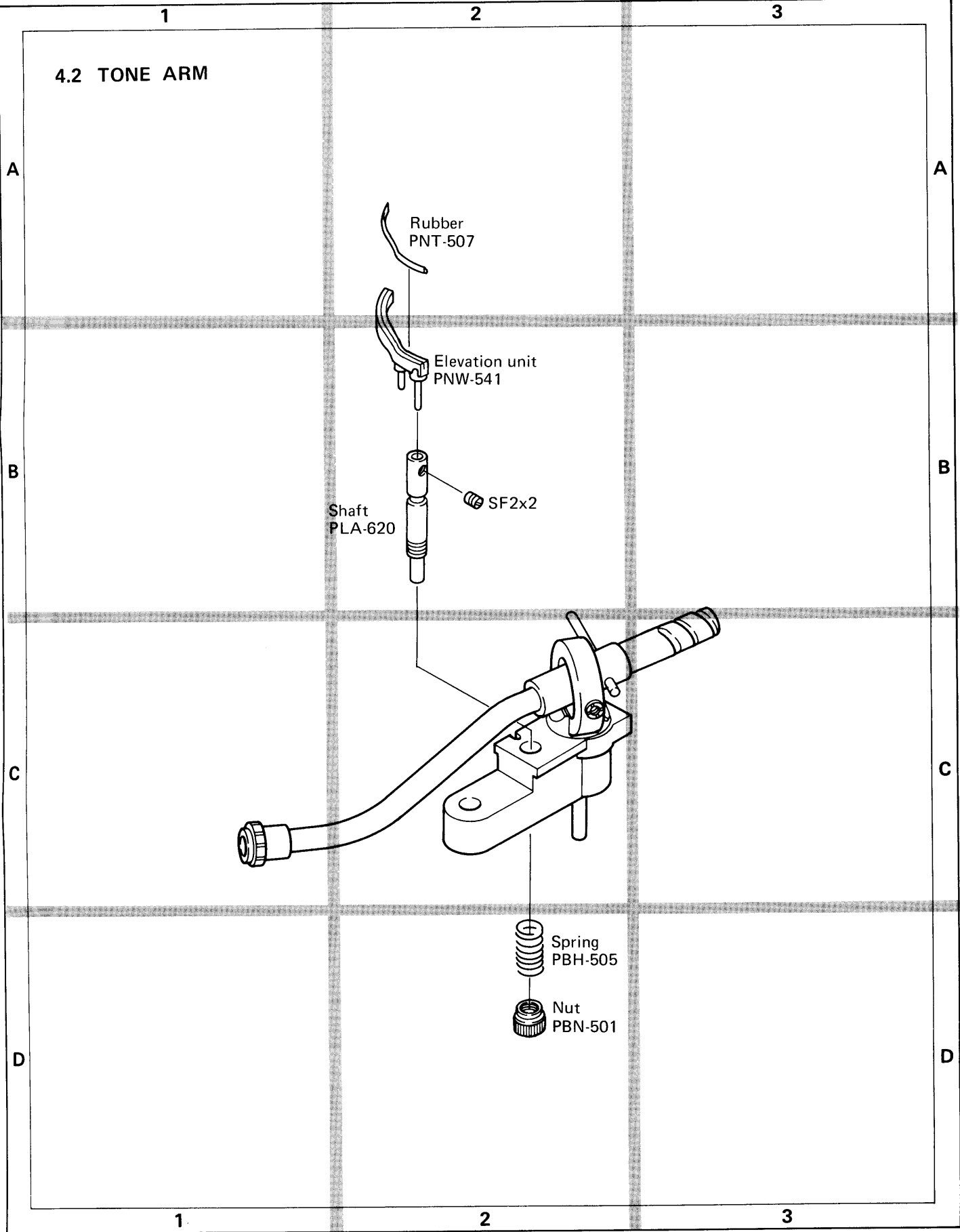

4.3 CABINET

Dust cover assembly
PXA-159

NOTE:
Parts indicated in green cannot be supplied.

A

B

C

D

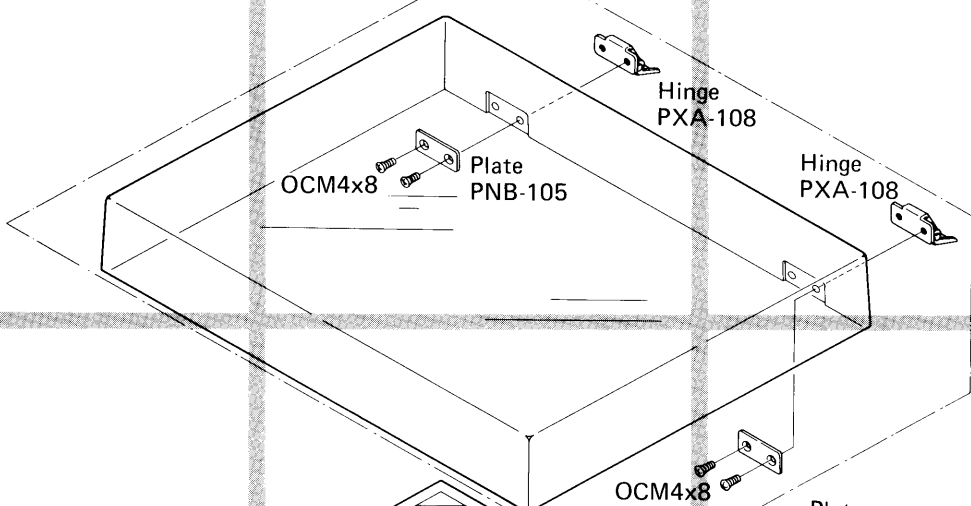

Name plate
PNEER

Screw
PBA-011

Cabinet
PMM-044

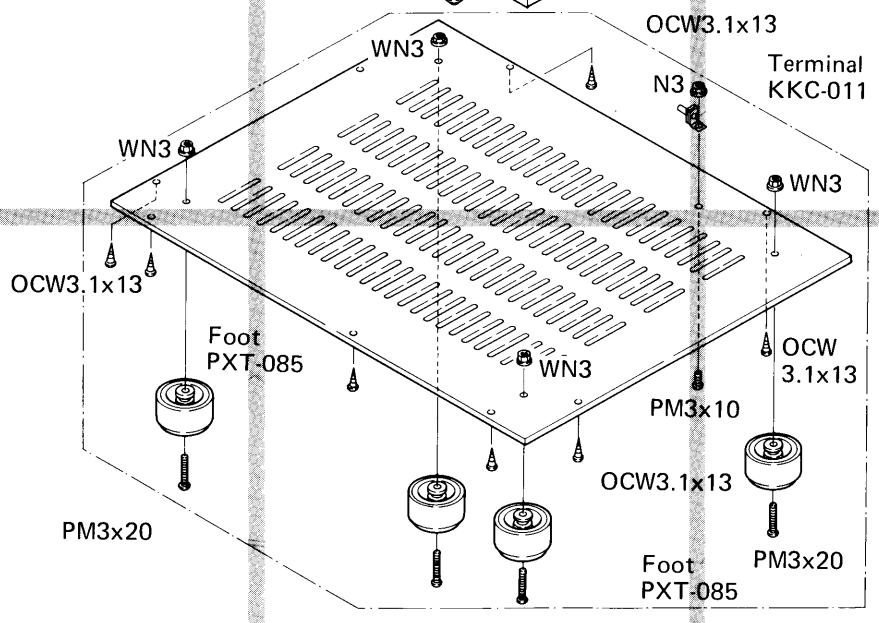
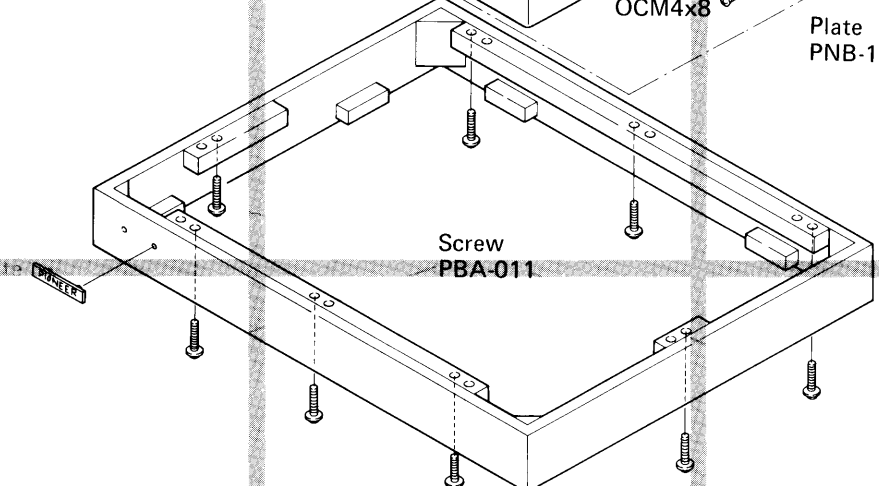

1 2 3

4.4 PACKING

NOTE:

Parts indicated in green cannot be supplied.

A

A

B

B

C

C

D

D

1

2

3

1

2

3

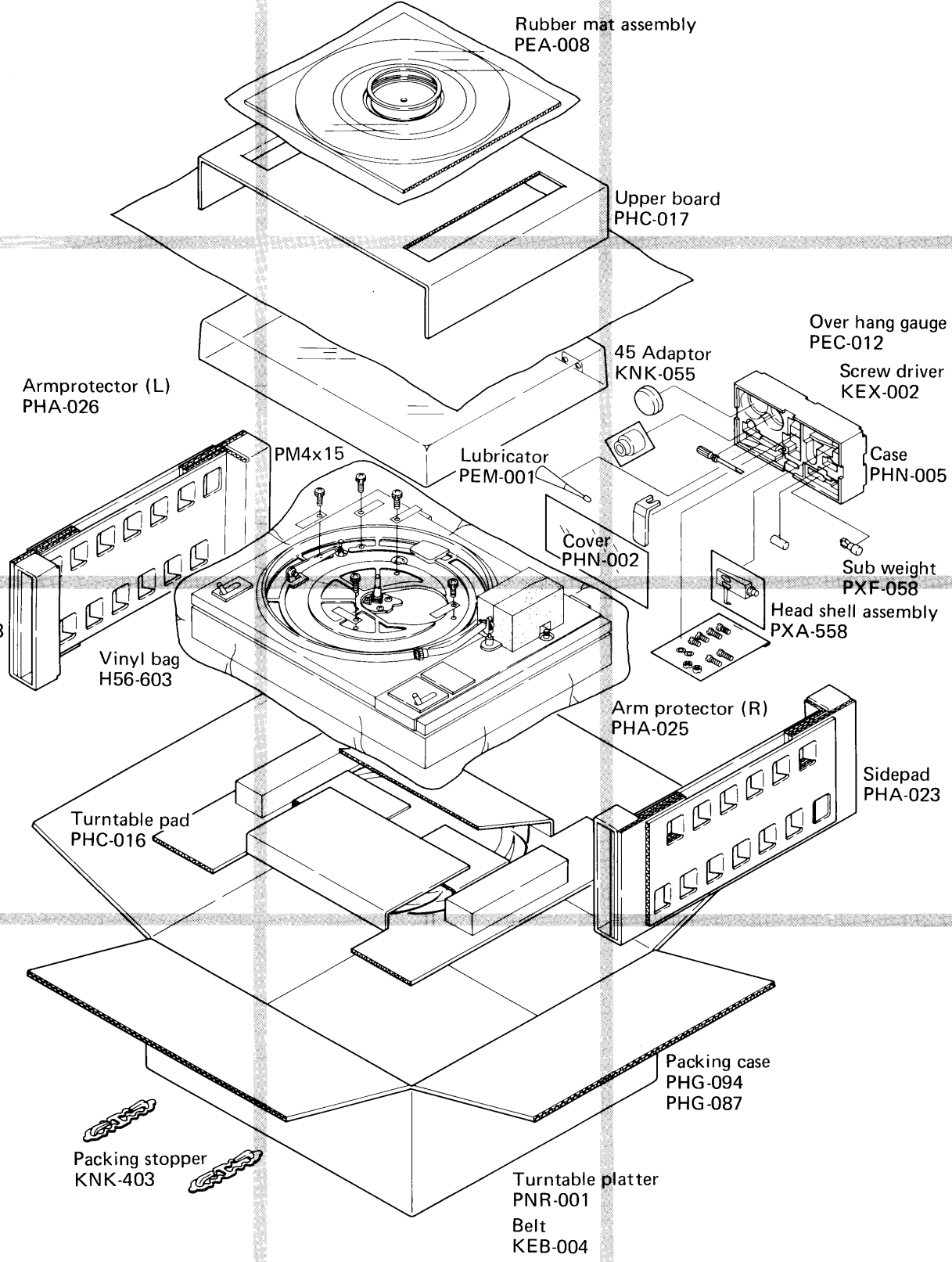

PIONEER ELECTRONIC CORPORATION

4-1, Meguro 1-Chome, Meguro-ku, Tokyo 153, Japan

U.S. PIONEER ELECTRONICS CORPORATION

75 Oxford Drive, Moonachie, New Jersey 07074, U.S.A.

PIONEER ELECTRONIC (EUROPE) N.V.

Luithagensteenweg no. 9, 2030 Antwerp, Belgium

PIONEER ELECTRONICS AUSTRALIA PTY. LTD.

178-184 Boundary Road, Braeside, Victoria 3195, Australia

© FEB. 1976 Printed in Japan