

PIONEER

Service Manual

**CIRCUIT & MECHANISM
DESCRIPTIONS
REPAIR & ADJUSTMENTS**



**ORDER NO.
ARP-741-0**

STEREO TURNTABLE

PL-3F

MODEL PL-3F COMES IN FIVE VERSIONS DISTINGUISHED AS FOLLOWS:

Type	Voltage	Remarks
KUT	AC120V only	U.S.A. model (Without cartridge)
HEMT	AC220V, 240V (switchable)	European continent model (Without cartridge)
HBT	AC220V, 240V (switchable)	United Kingdom model (Without cartridge)
S	AC110V, 120V, 220V, 240V (switchable)	General export model
S/G	AC110V, 120V, 220V, 240V (switchable)	U.S. Military model

- This service manual is applicable to the KUT, HEMT, HBT, S and S/G types.
As to the HEMT, HBT, S and S/G types, please refer to page 56 – 57.
- Ce manuel d'instruction se réfère au mode de réglage, en français. (P. 51, 52)
- Este manual de servicio trata del método de ajuste escrito en español. (P. 53, 54)

CONTENTS

1. SPECIFICATIONS	2	10. BLOCK DIAGRAM	25
2. FRONT PANEL FACILITIES	3	11. MECHANISM DESCRIPTIONS	27
3. DISASSEMBLY	5	12. CIRCUIT DESCRIPTIONS	33
4. PARTS LOCATIONS	8	13. TROUBLESHOOTING	43
5. EXPLODED VIEWS	10	14. ADJUSTMENTS	49
6. ELECTRICAL PARTS LIST	15	RÉGLAGE	51
7. P.C. BOARDS CONNECTION DIAGRAM	18	AJUSTE	53
8. SCHEMATIC DIAGRAM	21	15. SAFETY INFORMATION	55
9. PACKING	24	16. FOR HEMT, HBT, S AND S/G TYPES	56

QUESTIONNAIRE

MODEL _____

One Model per questionnaire

Dear Servicer,

Thank you for your cooperation in the post-sale service of Pioneer products.

This questionnaire is used as a tool to improve the serviceability of our products and service manuals. Please evaluate this model and service manual by answering the following questions. Your ideas may be realized in our future products. Your answers will be appreciated. Thank you.

PIONEER ELECTRONIC CORP.

T. Nakagawa, Manager, Service Section, International Division

1. SERVICING EVALUATION	Circle applicable number:	Good	Fair	Poor		
a. Disassembly/Re-assembly:		1	2	3	*4	*5
b. Circuit Checks:		1	2	3	*4	*5
c. Replacement of Parts:		1	2	3	*4	*5
d. Adjustment (s):		1	2	3	*4	*5

* If (4) or (5) was circled, please be specific.

e. Your advice, opinion or ideas related to servicing this product.

2. SERVICE MANUAL EVALUATION

a. Circuit & Mechanism Description

b. Circuit Diagram

3. OTHER

Please describe other areas of servicing which you may find difficult.

Completed by :

Date :

Company Name :

Address :

City/State/Zip :

Please send this form filled to the distributor in your country.

2. FRONT PANEL FACILITIES

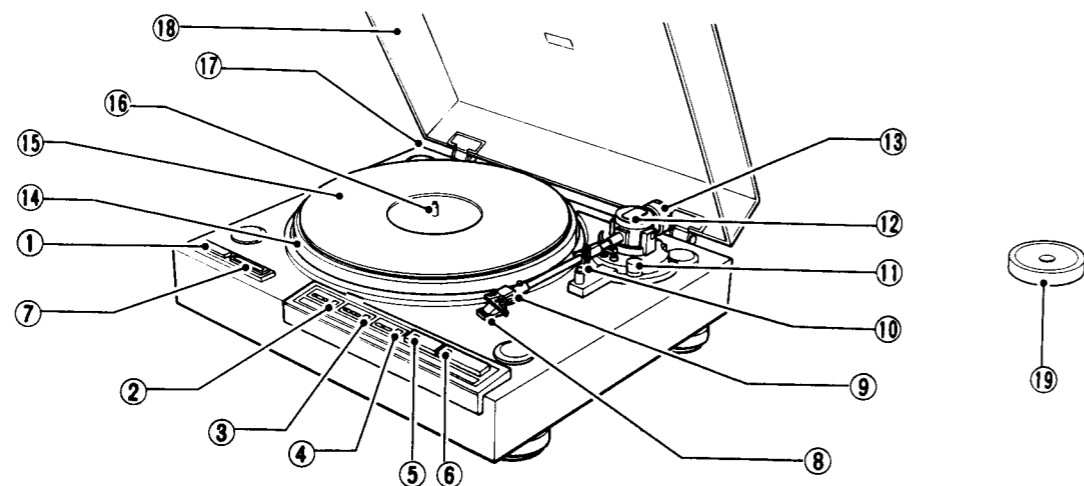

① POWER switch

Press this switch to turn the power on and off.
 [ON] (depressed position) : Power is switched ON.
 [OFF] (released position) ; Power is switched OFF.
 When the POWER switch is set to ON, the following switches are set automatically.

- SPEED switch _____ [33]
- SIZE switch _____ [30]
- REPEAT switch _____ [OFF]

② SPEED switch/indicator

Set this switch in accordance with the speed of the record which is to be played, so that the indicator lights.

[33] indicator lights:
 For playing 33-1/3 rpm records.

[45] indicator lights:
 For playing 45 rpm records.

③ SIZE switch/indicator

Set this switch in accordance with the size of the record which is to be played, so that the indicator lights.

[12" 30] indicator lights:
 For playing 30 cm (12") records.

[10" 25] indicator lights:
 For playing 25 cm (10") records.

[7" 17] indicator lights:
 For playing 17 cm (7") records.

④ REPEAT switch/indicator

Press this switch so that the indicator lights for repeat play.

⑤ ARM ELEVATION switch/indicator

- Use the switch for manual play.
- Use the switch to suspend record play temporarily.
- Use the switch when changing the tracks during manual play.

Indicator lights:
 The tonearm rises (the stylus moves away from the record).
 Indicator goes out:
 The tonearm descends (the stylus is lowered onto the record).

⑥ START/STOP switch

Depress this switch when starting auto play or when stopping play

⑦ Quartz locked indicator

This lights when the platter is rotating at exactly 33-1/3 or 45 revolutions per minute.

⑧ Cartridge (PC-7MC)

The cartridge supplied with this turntable is an MC (moving coil) type cartridge. Since this type of cartridge has a lower output than an MM (moving magnet) type, the turntable's output cord should be connected to your amplifier's MC input terminals. If your amplifier does not have MC terminals, use a separate transformer and head amplifier for MC cartridges.

NOTE:

A cartridge is not provided with the European, U.K. and U.S.A. models and so your own cartridge should be mounted, following the instructions laid down in CARTRIDGE MOUNTING.

⑨ Headshell

⑩ Arm rest

This serves to hold and clamp the tonearm. When moving the tonearm, release the clamp.

⑪ Anti-skate control

This is rotated when performing the anti-skating adjustment.

⑫ Tonearm

⑬ Tracking force adjustment weight

This is used when adjusting the tracking force.

⑭ Platter

⑮ Rubber mat

⑯ Platter shaft

⑰ Cabinet

⑱ Dust cover

⑲ EP adapter

This is used when playing records with a "large center hole."

3. DISASSEMBLY

● **Bottom Plate**

1. Fix the tonearm to the arm rest, and remove the dust cover, rubber mat, and turntable platter.
2. Remove 4 insulator caps.
3. Remove the 4 screws labeled ①; and the bottom plate will be released.

● **Motor**

4. Remove the 4 screws labeled ②, and remove the control unit.
5. Remove the screw labeled ③, and disconnect the ground lead.
6. Remove the 3 screws labeled ④ to release the motor.

● **Mechanism Section**

7. Remove the 3 screws labeled ⑤ to release the mechanism section.

● **Sensor Assembly**

8. Remove the 2 screws labeled ⑥, then remove the tonearm leads and connector; the sensor assembly will be released.

● **Removing the only the Tonearm Section**

1. Remove the bottom plate according to the method described previously.
2. Remove the tonearm leads from the sensor assembly.
3. Loosen the screw labeled ① and remove the PU plate. Then loosen the screw labeled ②, release the arm rest lock, and pull the tonearm section slowly upwards.

● **Removing the Tonearm Section and the Arm Base at the Same Time**

1. Remove the bottom plate according to the procedure described previously.
2. Remove the 3 screws labeled ③, and remove the mechanism.
3. Disconnect the tonearm lead and remove the two screws labeled ④, the sensor assembly will be released.
4. Loosen the screw labeled ①, and remove the PU plate.
5. Remove the 2 screws labeled ⑥.
6. Remove the 4 screws labeled ⑤, the tonearm section and the arm base will be released.

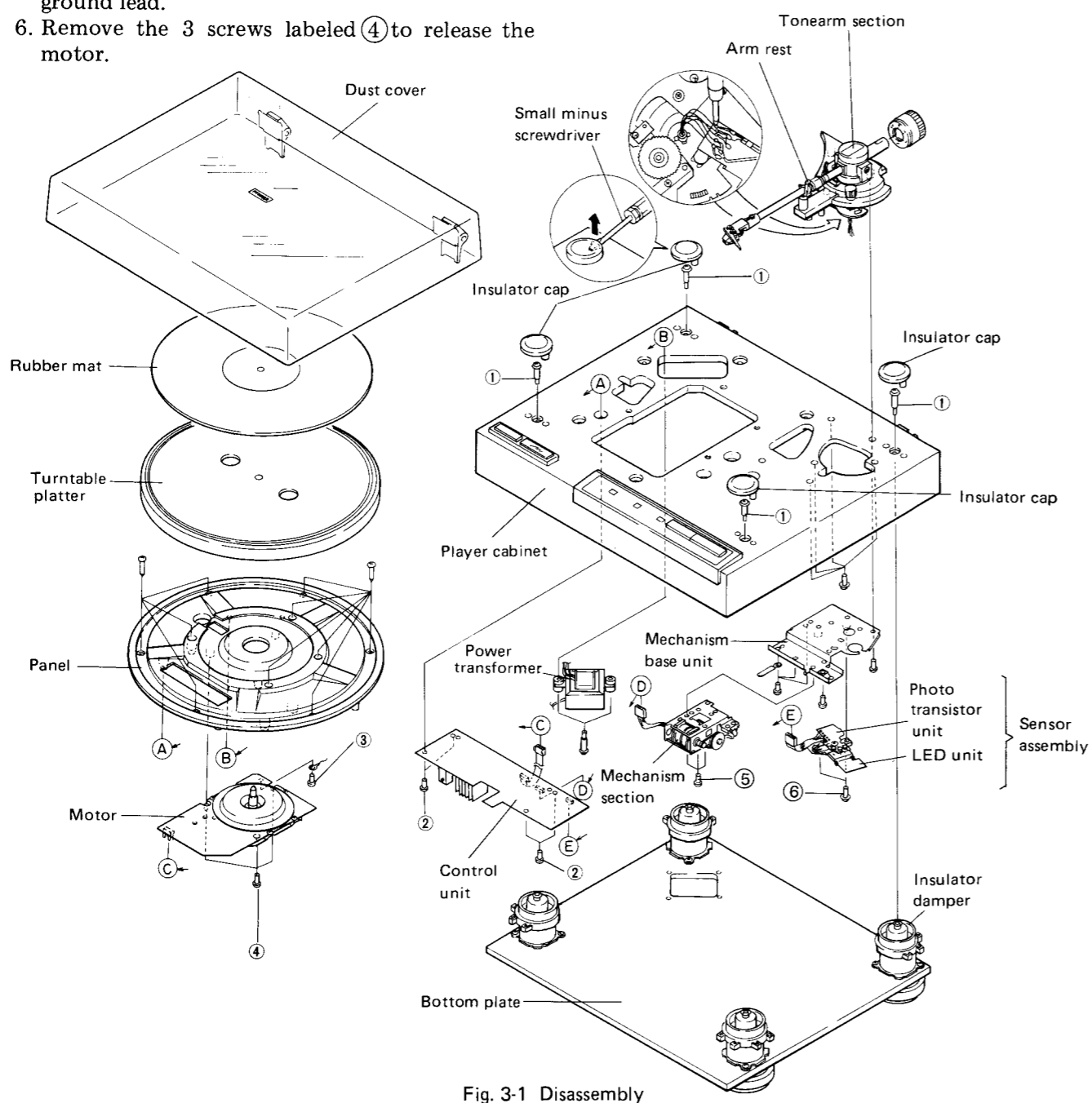

Fig. 3-1 Disassembly

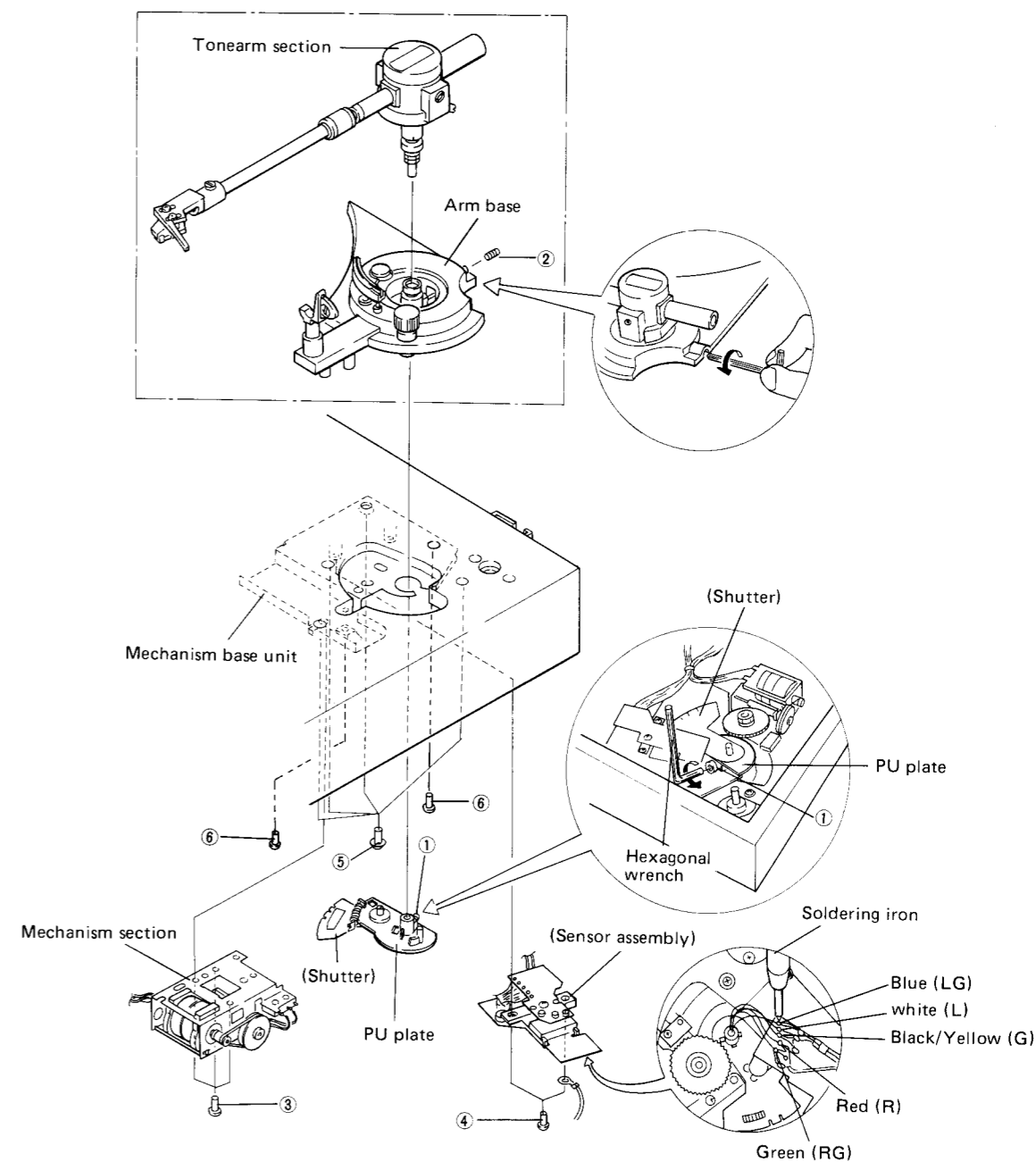

Fig. 3-2 Tonearm section remove

● **Installing the PU Plate and the Shutter**

1. Assemble the PU plate and the shutter so that their edges are lined together.
2. Turn the shutter so that its A point (see figure) is at the triangle mark of the mechanism base unit.
3. Leave 13.8 mm between the PU plate and the mechanism base unit. Fix the PU plate with a screw, using a hexagonal wrench, in the reverse procedure of removal.

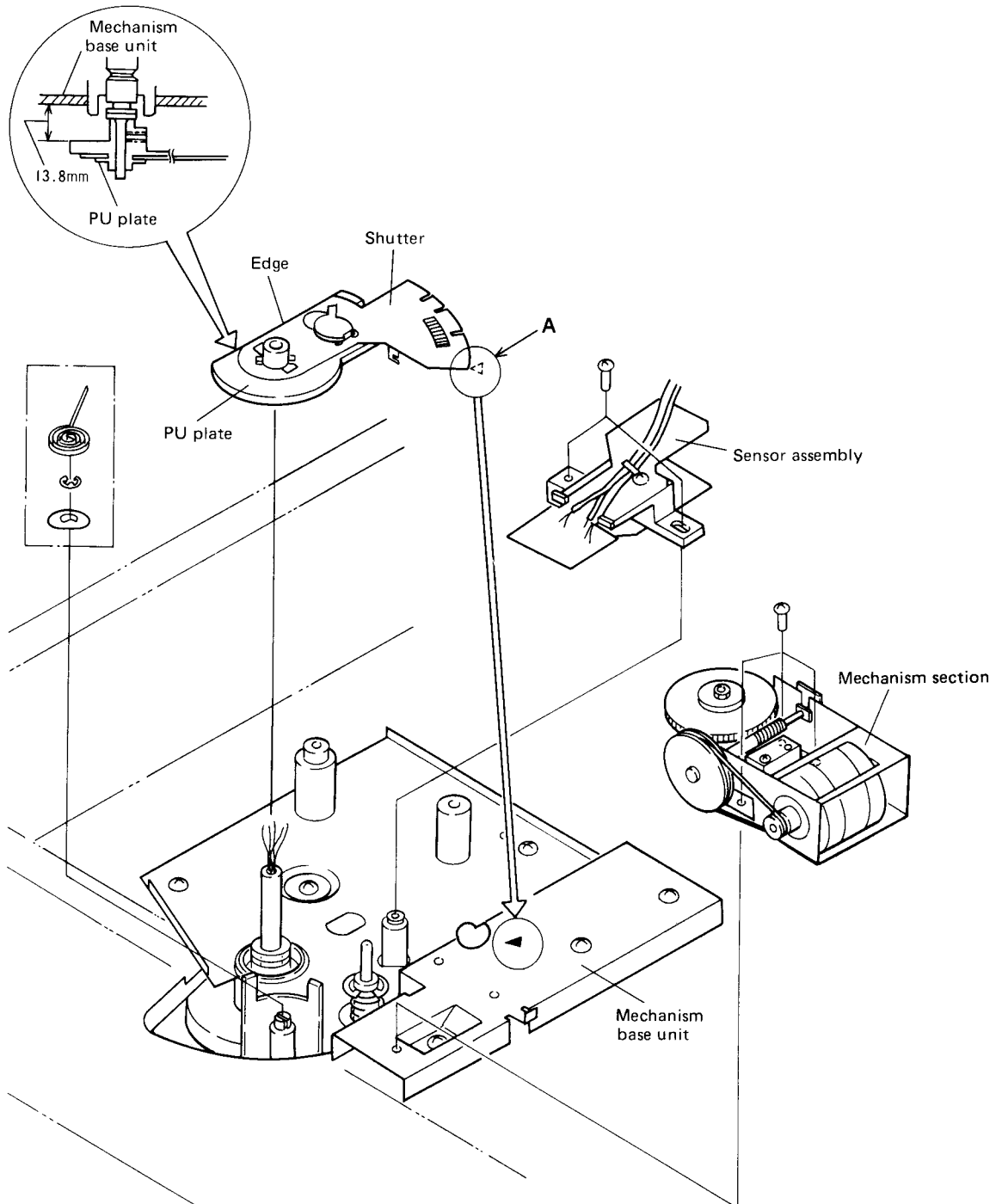



Fig. 3-3 PU plate attachment

4. PARTS LOCATIONS

NOTES:

- The  mark found on some component parts indicates the importance of the safety factor of the part. Therefore, when replacing, be sure to use parts of identical designation.
- For your Parts Stock Control, the fast moving items are indicated with the marks **★★** and **★**.
★★ GENERALLY MOVES FASTER THAN ★
 This classification shall be adjusted by each distributor because it depends on model number, temperature, humidity, etc.

Front View

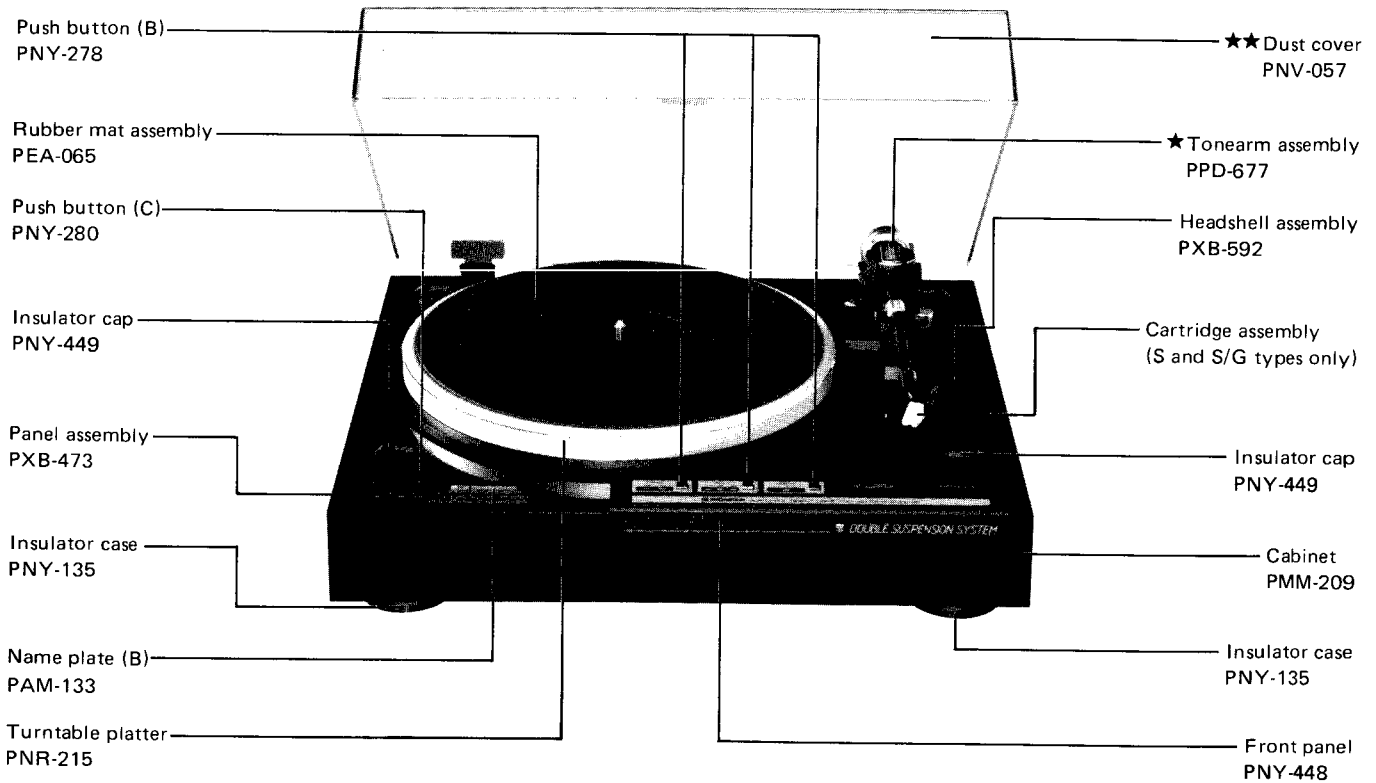

Rear View

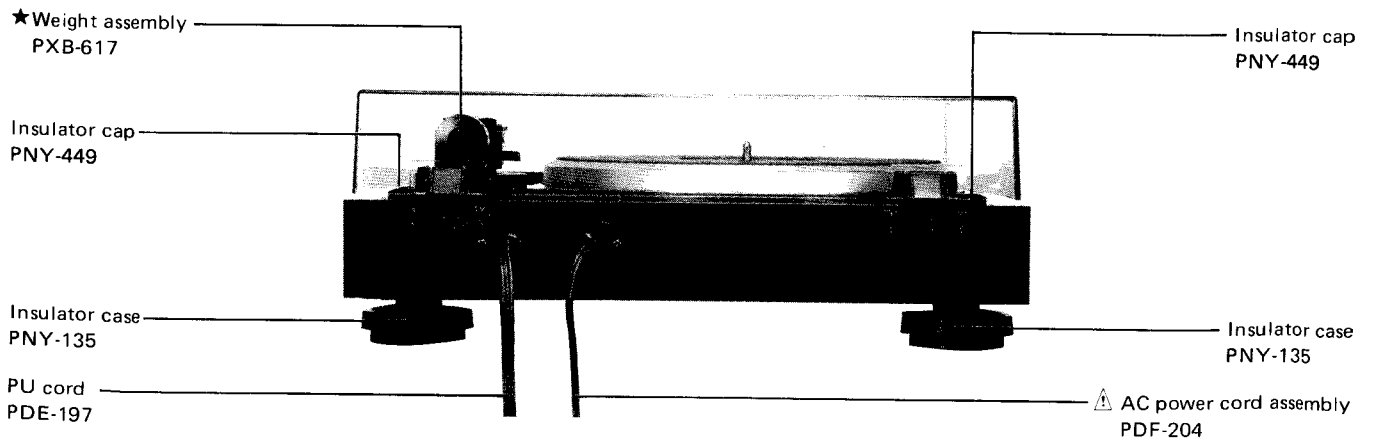

Inside View with Bottom Plate Removed

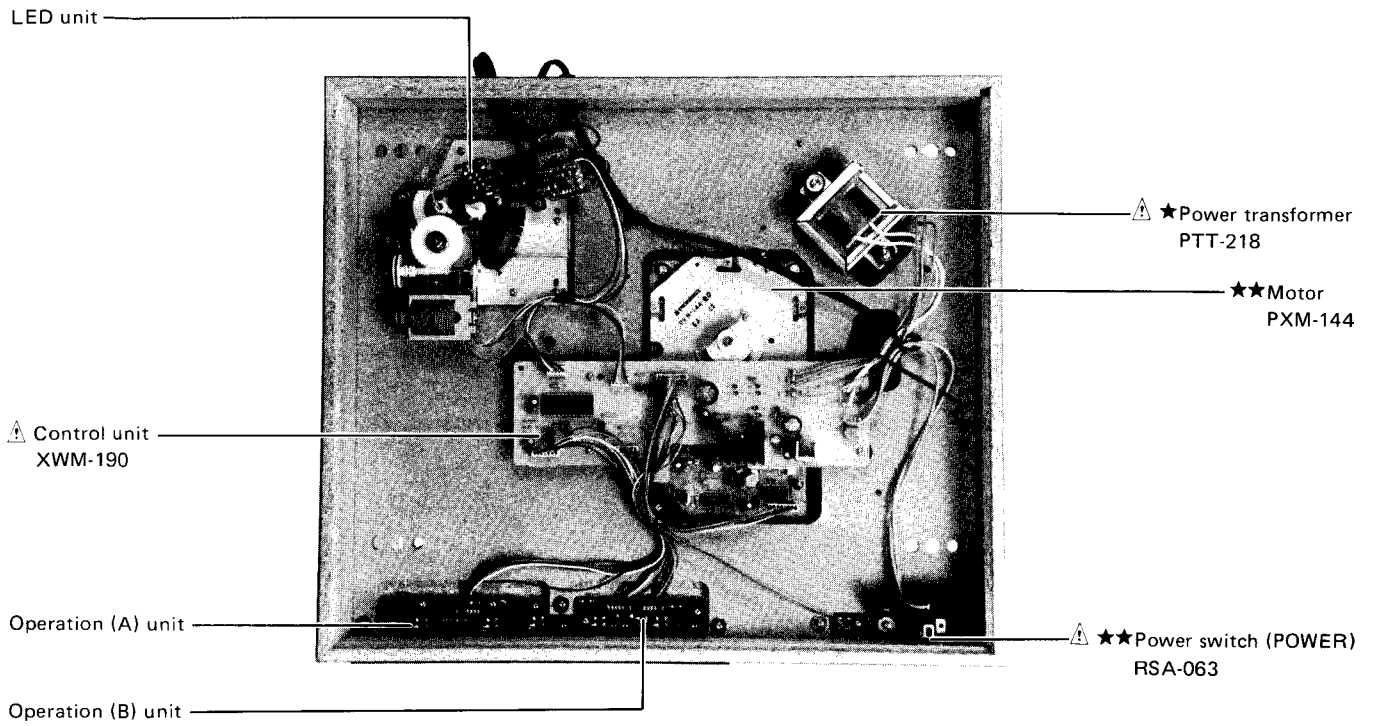

Mechanism View (Sensor Section)

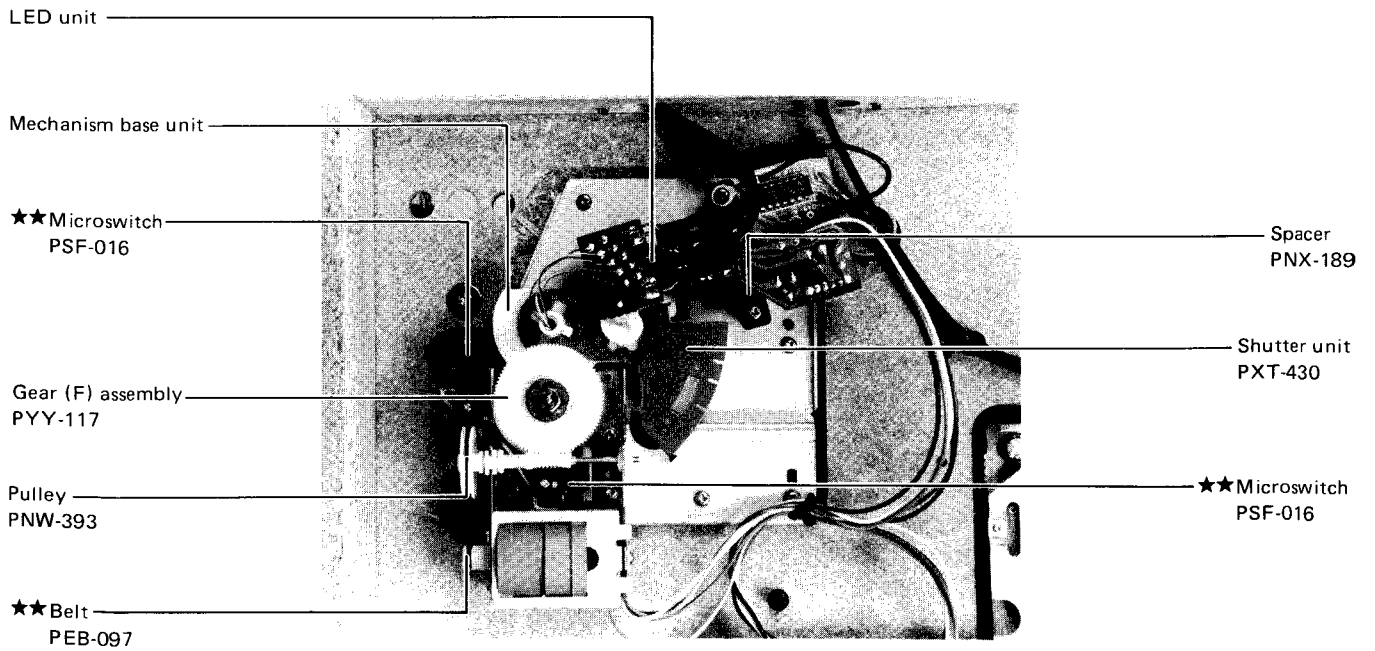





5. EXPLODED VIEWS

5.1 EXTERIOR

NOTES:

- *Parts without part number cannot be supplied.*
- *The  mark found on some component parts indicates the importance of the safety factor of the part. Therefore, when replacing, be sure to use parts of identical designation.*
- *For your Parts Stock Control, the fast moving items are indicated with the marks **★★** and **★**.*
★★ GENERALLY MOVES FASTER THAN ★
This classification shall be adjusted by each distributor because it depends on model number, temperature, humidity, etc.

Parts List of Exterior

Mark	No.	Part No.	Description	Mark	No.	Part No.	Description	
	1.	PNY-285	Panel		36.	PBA-144	Clamp screw	
	2.	PNY-448	Front Panel		37.	PBA-159	Screw	
	3.	PXB-472	Push button unit		38.	PBA-165	Screw (M4 x 16)	
	4.		...		39.	PBA-179	Screw	
	5.	PNY-278	Push button (B)		40.	PDZ30P080FMC	Screw 3 x 8	
	6.	PAM-131	Name plate (A)		41.	PPZ30P100FMC	Screw 3 x 10	
	7.	PXB-473	Panel assembly		42.	PDZ30P060FMC	Screw 3 x 6	
	8.		...		43.	PYC30P120FZK	Screw 3 x 12	
	★★	9.	RSA-063	Power switch (POWER)		44.	PMA30P060FMC	Screw 3 x 6
	10.	PAM-133	Name plate (B)		45.		
	11.	PNR-215	Turntable platter		46.	PPC30P080FMC	Screw 3 x 8	
	12.	PEA-065	Rubber mat assembly		47.	PNC-183	Slit plate	
	★★	13.	PXM-144	Motor		48.	PNX-189	Spacer
	★	14.	PPD-677	Tonearm assembly		49.	PYY-177	Gear (F) assembly
	15.	PXB-592	Headshell assembly		101.		Shield plate	
	16.	PNY-127	PU plate		102.		
	17.	ZMD40H140FZK	Screw 4 x 14		103.		Mechanism base unit	
	18.	PXT-430	Shutter unit		104.		Connector assembly	
		19.	PDF-204	AC power cord assembly		105.	Operation (A) unit	
		20.	XWM-190	Control unit		106.	Operation (B) unit	
	★	21.	PTT-218	Power transformer		107.	Indication unit	
	22.	PEC-051	Strain relief		108.		Photo transistor unit	
	23.	PEB-250	Rubber		109.		LED unit	
	24.	PDE-197	PU cord		110.		Cord holder	
	25.	PMM-209	Cabinet		111.		Lock plate (L)	
	★	26.	PXB-326	Hinge assembly		112.	Lock plate (R)	
	27.	PNY-255	Under case		113.		Screw 4 x 12	
	28.	PEB-306	Insulator damper		114.		Bottom plate	
	29.	PXV-048	Insulator unit		115.		Cover	
	30.	PEB-276	Lateral damper		116.		Rubber foot	
	31.	PNY-135	Insulator case					
	32.	PBH-427	Insulator spring					
	33.	PNY-449	Insulator cap					
★★	34.	PNV-057	Dust cover					
★	35.	PXB-617	Weight assembly					

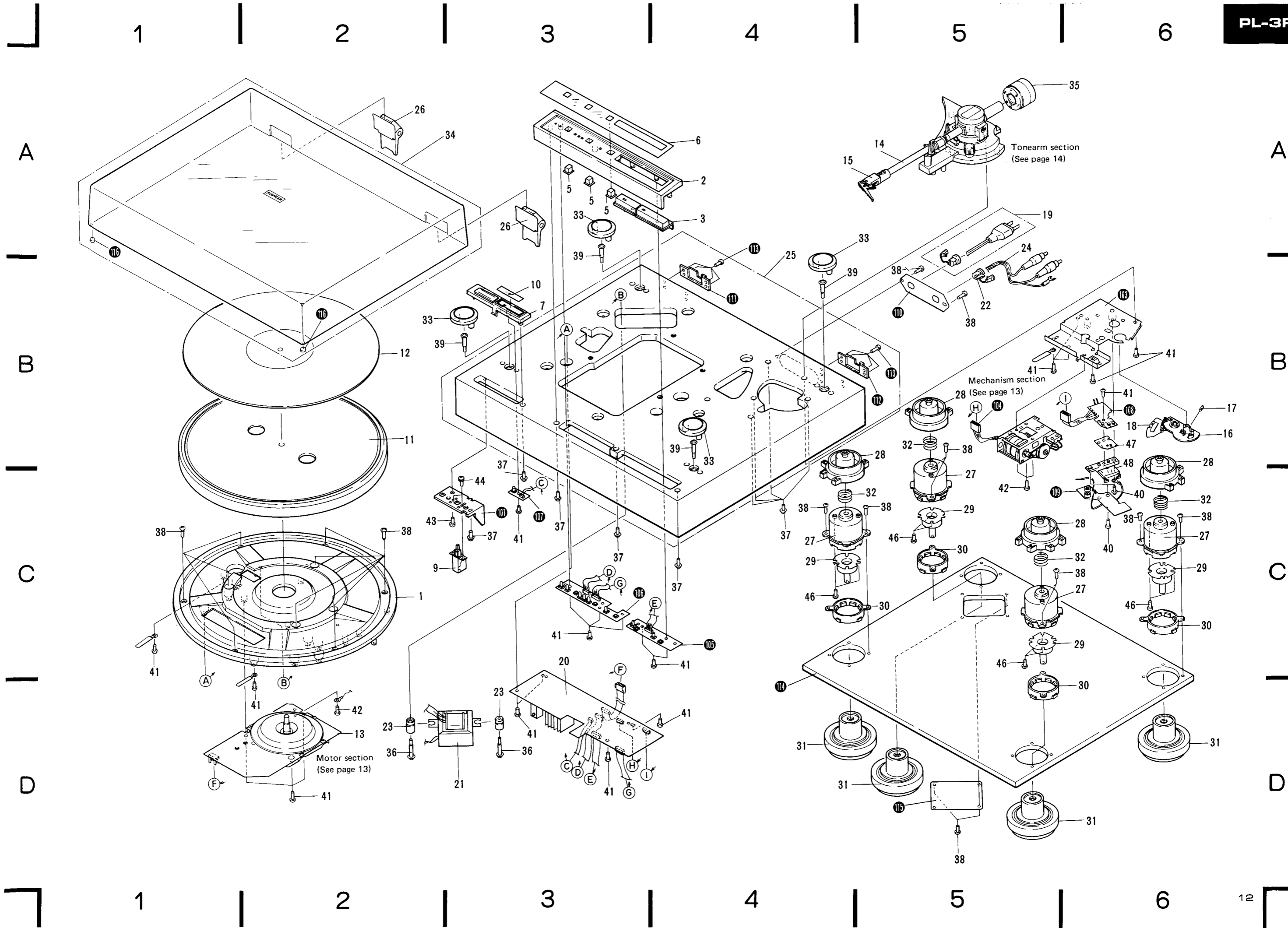

5.2 MECHANISM ASSEMBLY

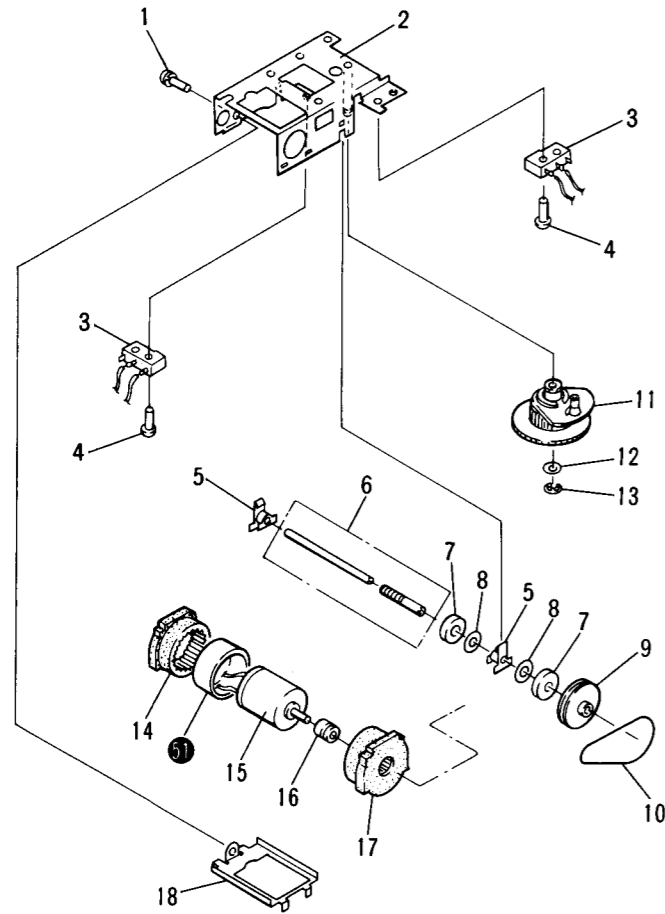

Parts List of Mechanism

Mark	No.	Part No.	Description
	1.	PMA26P050FMC	Screw 2.6 x 5
	2.	PXT-322	Chassis unit (F)
★ ★	3.	PSF-016	Microswitch
	4.	PMZ20G100FMC	Screw 2 x 10
	5.	PNW-391	Collar
	6.	PNW-485	Worm unit
	7.	PED-010	Felt washer
	8.	PBF-009	Nylon washer
	9.	PNW-393	Pulley
	10.	PEB-097	Belt
	11.	PYY-117	Gear (F) assembly
	12.	WA31D054D050	Washer
	13.	YE25S	Washer
	14.	PEB-249	Damper rubber (B)
★ ★	15.	PXM-086	Motor
	16.	PLM-008	Motor pulley
	17.	PEB-248	Damper rubber (A)
	18.	PNC-300	Frame
	51.		Shield plate

5.3 MOTOR

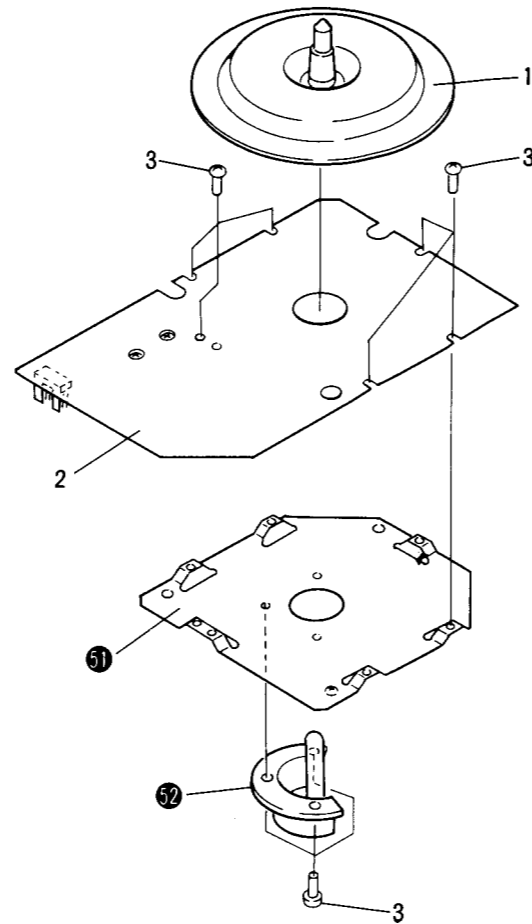

Parts List of Motor

Mark	No.	Part No.	Description
	1.	PXV-098	Rotor unit
	2.	PWM-138	Circuit unit
	3.	PSZ30P050FMC	Screw 3 x 5
	51.		Base
	52.		Spindle base unit

5.4 TONEARM SECTION

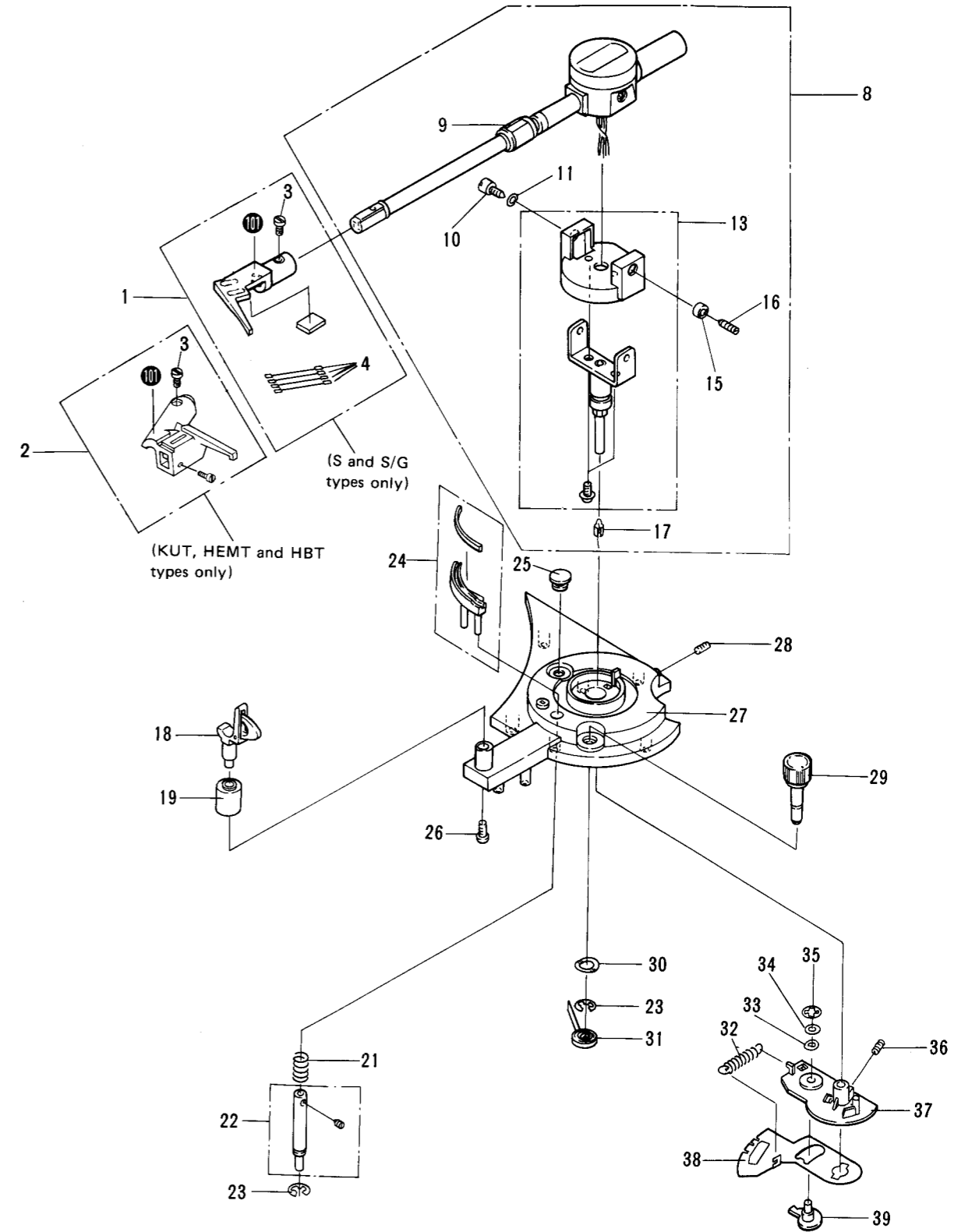

Parts List of Tonearm Assembly

Mark	No.	Part No.	Description	Mark	No.	Part No.	Description
	1.	PXB-564	Head shell		26.	PPZ30P080FMC	Screw 3 x 8
	2.	PXB-592	Head shell		27.	PNY-283	Arm base
	3.	PBA-533	Screw		28.	ZMK40M080FZK	Screw 4 x 8
	4.	PDF-544	Terminal chip unit		29.	PAD-128	AS knob unit
	5.		30.	PBE-012	AS spring washer
	6.		31.	PBH-268	AS whirl around spring
	7.		32.	PBH-364	PU plate spring
	8.	PPD-677	Tonearm assembly		33.	PBE-019	PU spring washer
	9.	PXB-619	Pipe holder assembly		34.	WC40FMC	Washer
	10.	PLB-727	Pivot screw		35.	YS40S	Washer
	11.	WS30FMC	Washer		36.	ZMD40H140FZK	Screw 4 x 14
	12.		37.	PNY-127	PU plate
	13.	PXB-620	Outside holder assembly		38.	PXT-430	Shutter unit
	14.		39.	PNW-592	Adjustment cam
	15.	PLB-718	Pivot lock nut		101.	Headshell
	16.	PLA-580	Pivot				
	17.	PDF-514	Ground lug unit				
	18.	PXB-324	Rest assembly				
	19.	PAB-035	Rest cap				
	20.				
	21.	PBH-166	EV spring				
	22.	PLB-207	EV lever				
	23.	YE50S	Washer				
	24.	PXB-210	EV sheet assembly				
	25.	PEB-300	Rubber buch				

6. ELECTRICAL PARTS LIST

NOTES:

- When ordering resistors, first convert resistance values into code form as shown in the following examples.
Ex. 1 When there are 2 effective digits (any digit apart from 0), such as 560 ohm and 47k ohm (tolerance is shown by J=5%, and K=10%).
 560Ω 56×10^1 $561 \dots RD\frac{1}{4}PS$ $\begin{matrix} 5 & 6 & 1 \\ \hline \end{matrix}$ J
 $47k\Omega$ 47×10^3 $473 \dots RD\frac{1}{4}PS$ $\begin{matrix} 4 & 7 & 3 \\ \hline \end{matrix}$ J
 0.5Ω $0R5$ $RN2H$ $\begin{matrix} 0 & 5 & 0 \\ \hline \end{matrix}$ K
 1Ω 010 $RS1P$ $\begin{matrix} 0 & 1 & 0 \\ \hline \end{matrix}$ K
Ex. 2 When there are 3 effective digits (such as in high precision metal film resistors).
 $5.62k\Omega$ 562×10^1 $5621 \dots RN\frac{1}{4}SR$ $\begin{matrix} 5 & 6 & 2 & 1 \\ \hline \end{matrix}$ F
- The Δ mark found on some component parts indicates the importance of the safety factor of the part. Therefore, when replacing, be sure to use parts of identical designation.
- For your Parts Stock Control, the fast moving items are indicated with the marks **★★** and **★**.
★★ GENERALLY MOVES FASTER THAN ★
 This classification shall be adjusted by each distributor because it depends on model number, temperature, humidity, etc.

Miscellaneous Parts

ASSEMBLIES

Mark	Symbol & Description	Part No.
	Circuit board assembly	
Δ	{ Control unit	XWM-190
	{ Operation (A) unit	Non supply
	{ Operation (B) unit	Non supply
	{ Indication unit	Non supply
	Sensor assembly	
	{ Photo transistor unit	Non supply
	{ LED unit	Non supply
	Circuit unit	PWM-138
	(Motor assembly · PXM-144)	

OTHERS

Mark	Symbol & Description	Part No.
Δ ★★	Power switch (POWER)	RSA-063
★★	Motor	PXM-144
★★	Motor	PXM-086
★★	Microswitch	PSF-016
Δ ★★	AC power cord assembly	PDF-204
Δ ★	Power transformer	PTT-218
	PU cord	PDE-197

Control Unit (XWM-190)

SEMICONDUCTORS

Mark	Symbol & Description	Part No.
★★	Q1	PD6003
★★	Q2	BA6208
★★	Q3	NJM78M05A
★★	Q4	2SD1275
★★	Q5	2SC1740S
★★	Q6 - Q11	2SA933S
Δ ★	D1 - D8	DSA1A1 (DSA1A2)
★	D9	RD27EB1 (RD27EB2) (RD27EB3)
★	D10, D11	IS2473

COIL

Mark	Symbol & Description	Part No.
	L1 (22 μ H)	LAL03T220k

CAPACITORS

Mark	Symbol & Description	Part No.
Δ	C1 Ceramic capacitor (0.01/AC250V)	PCL-040
	C3	CEA1R0M50
	C7	CEA100M16
	C4	CEA101M35L
	C8	CEA220M10
	C5	CEA4R7M35
	C2	CEA471M25L
	C6	CEA471M50L
	C9	CKDYF103Z50

RESISTORS

NOTE: When ordering resistors, convert the resistance value into code form, and then rewrite the part no. as before.

Mark	Symbol & Description	Part No.
	R1	RS2PMF222J
	R2 - R6	RD1/6PM $\square \square \square J$

OTHERS

Mark	Symbol & Description	Part No.
	Ceramic resonator (3MHz + 100P)	KMFC1033S

Operation (A) Unit

SEMICONDUCTORS

Mark	Symbol & Description	Part No.
★	D12, D13	SLH-56VC3H

SWITCHES

Mark	Symbol & Description	Part No.
★★	S4 Tact switch (START/STOP)	PSG-052
★★	S5 Tact switch (ARM-ELEVATION)	PSG-052

RESISTORS

Mark	Symbol & Description	Part No.
	R11, R12	RD1/6PM471J

Operation (B) Unit

SEMICONDUCTORS

Mark	Symbol & Description	Part No.
★	D14 - D19	SLH-56VC3H

SWITCHES

Mark	Symbol & Description	Part No.
★★	S6 Tact switch (REPEAT)	PSG-052
★★	S7 Tact switch (SIZE)	PSG-052
★★	S8 Tact switch (SPEED)	PSG-052

Miscellaneous Parts

ASSEMBLIES

Mark	Symbol & Description	Part No.
	Circuit board assembly	
⚠	Control unit	XWM-190
	Operation (A) unit	Non supply
	Operation (B) unit	Non supply
	Indication unit	Non supply
	Sensor assembly	
	Photo transistor unit	Non supply
	LED unit	Non supply
	Circuit unit (Motor assembly · PXM-144)	PWM-138

OTHERS

Mark	Symbol & Description	Part No.
⚠	★★ Power switch (POWER)	RSA-063
	★★ Motor	PXM-144
	★★ Motor	PXM-086
	★★ Microswitch	PSF-016
⚠	AC power cord assembly	PDF-204
⚠	★ Power transformer PU cord	PTT-218 PDE-197

Control Unit (XWM-190)

SEMICONDUCTORS

Mark	Symbol & Description	Part No.
★★	Q1	PD6003
★★	Q2	BA6208
★★	Q3	NJM78M05A
★★	Q4	2SD1275
★★	Q5	2SC1740S
★★	Q6 - Q11	2SA933S
⚠	★ D1 - D8	DSA1A1 (DSA1A2)
★	D9	RD27EB1 (RD27EB2) (RD27EB3)
★	D10, D11	IS2473

COIL

Mark	Symbol & Description	Part No.
	L1 (22 μH)	LAL03T220k

CAPACITORS

Mark	Symbol & Description	Part No.
⚠	C1 Ceramic capacitor (0.01/AC250V)	PCL-040
	C3	CEA1R0M50
	C7	CEA100M16
	C4	CEA101M35L
	C8	CEA220M10
	C5	CEA4R7M35
	C2	CEA471M25L
	C6	CEA471M50L
	C9	CKDYF103Z50

RESISTORS

NOTE: When ordering resistors, convert the resistance value into code form, and then rewrite the part no. as before.

Mark	Symbol & Description	Part No.
	R1	RS2PMF222J
	R2 - R6	RD1/6PM □□□J

OTHERS

Mark	Symbol & Description	Part No.
	Ceramic resonator (3MHz + 100P)	KMFC1033S

Operation (A) Unit

SEMICONDUCTORS

Mark	Symbol & Description	Part No.
★	D12, D13	SLH-56VC3H

SWITCHES

Mark	Symbol & Description	Part No.
★★	S4 Tact switch (START/STOP)	PSG-052
★★	S5 Tact switch (ARM-ELEVATION)	PSG-052

RESISTORS

Mark	Symbol & Description	Part No.
	R11, R12	RD1/6PM471J

Operation (B) Unit

SEMICONDUCTORS

Mark	Symbol & Description	Part No.
★	D14 - D19	SLH-56VC3H

SWITCHES

Mark	Symbol & Description	Part No.
★★	S6 Tact switch (REPEAT)	PSG-052
★★	S7 Tact switch (SIZE)	PSG-052
★★	S8 Tact switch (SPEED)	PSG-052

RESISTORS

Mark	Symbol & Description	Part No.
	R13 - R15	PD1/6PM471J

Indication Unit

SEMICONDUCTOR

Mark	Symbol & Description	Part No.
★	D20	SLH-56VC3H

RESISTOR

Mark	Symbol & Description	Part No.
	R16	RD1/6PM471J

OTHERS

Mark	Symbol & Description	Part No.
	Screw 3 x 6 (For Q4 heat sink)	PMAP060FMC
	Screw 3 x 6 (For Q3 heat sink)	VBZ30P060FMC

Photo Transistor Unit

SEMICONDUCTORS

Mark	Symbol & Description	Part No.
★★	IC1	TC4011BP
★★	Q1 - Q3	μPD4011BC PH101-S

RESISTORS

Mark	Symbol & Description	Part No.
	R1	RMLS4-822J (RGSD4X822J)

LED Unit

SEMICONDUCTORS

Mark	Symbol & Description	Part No.
★	D1 - D3	TLR-121

RESISTORS

Mark	Symbol & Description	Part No.
★	VR1, VR2 Semi-fixed (22kΩ-B)	PCP-013
	R2	RMLS5-561J (RGSD5X561J)

OTHERS

Mark	Symbol & Description	Part No.
	Screw 3 x 8	PPZ30P080FMC
	Slit plate	PNC-183
	Spacer	PNX-189

CIRCUIT UNIT (PWM-138)
(MOTOR · PXM-144)

SEMICONDUCTORS

Mark	Symbol & Description	Part No.
★★	IC1	PA2007
★★	IC2	PA2008
★★	IC3	PD1007 (PD0008) (PD1003) TD62503P
★★	IC4	2SC1815 (2SC945) (2SC2458) (2SC1740LN)
★★	Q1	1S2473
★	D1	1S2473

CAPACITORS

Mark	Symbol & Description	Part No.
	C5	CQMA123K50
	C8	CQPA473J50
	C2, C4, C9, C12	CKDYF103Z50
	C15 - C18	CKDYF223Z50
	C1	CCDCH330J50
	C3	CCDCH560J50
	C6, C7	CKDYX104M25 (PCL-046)
	C19	CEANLR22M50
	C11, C20	CEAR47M50
	C13, C22	CEA010M50
	C10	CEA100M16
	C23 - C26, C29	CEA100M35
	C30	CEA330M10
	C14	CEA101M10
	C21	CSZAR22M35
	C27, C28	CEANP470M25

RESISTORS

NOTE: When ordering resistors, convert the resistance value into code form, and then rewrite the part no. as before.

Mark	Symbol & Description	Part No.
★	VR1 Semi-fixed (15k-B)	PCP-006
★	VR2 Semi-fixed (47k-B)	PCP-072
	R11	RD1/2PS2R2J
	R3, R4	RN1/4PQ □□□□F RD1/4PM □□□J
	Other resistors	

OTHERS

Mark	Symbol & Description	Part No.
HA, HB	Hall element H-2	PCX-057
★	X'tal Crystal resonator	PSS-003
	Earth terminal	PNH-199
	Connector pin (7P)	SD-5048-07A
	Screw 3 x 5	PSZ30P050FMC

7. P.C. BOARDS CONNECTION DIAGRAM

A

B

C

D

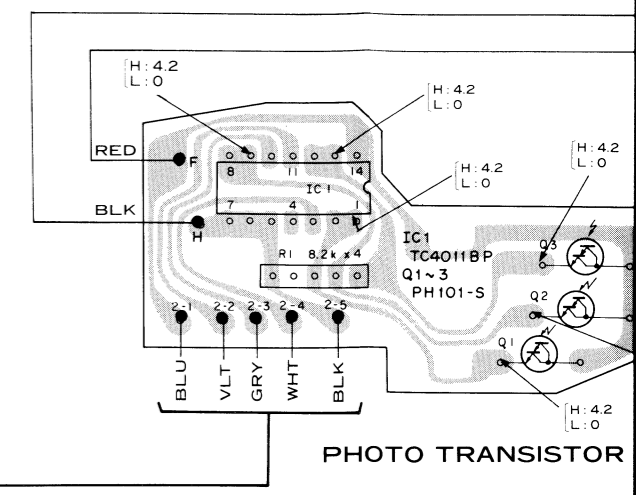
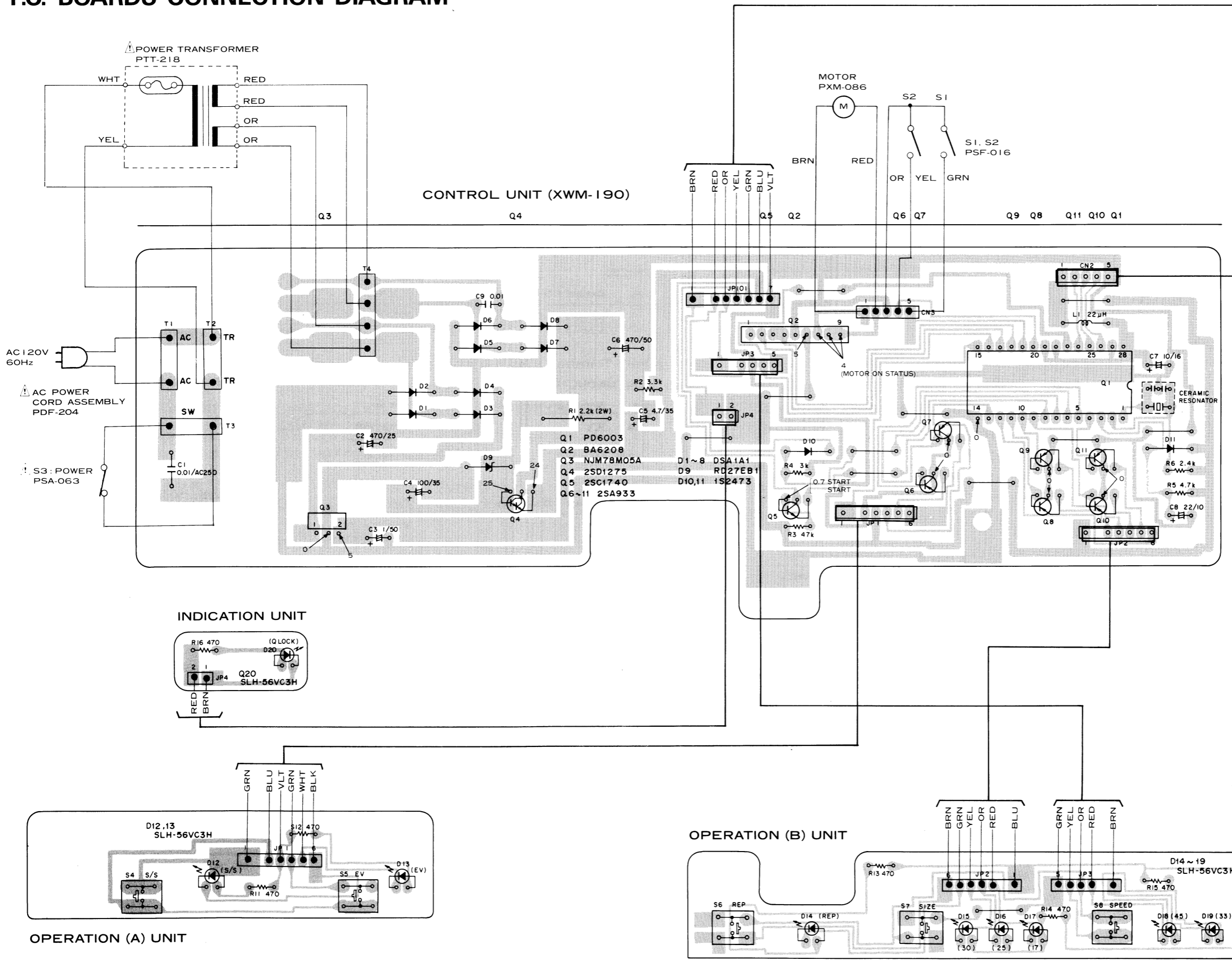

MOTOR (PXM-144)

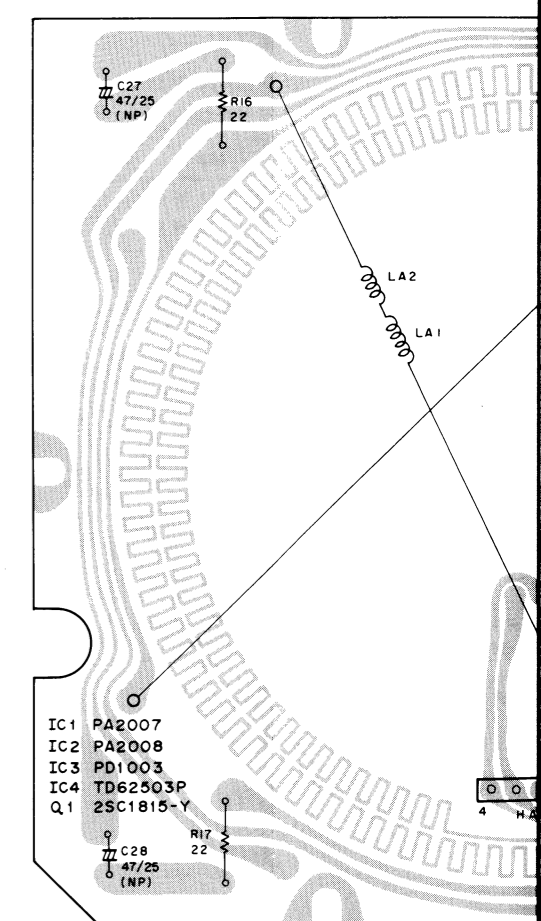

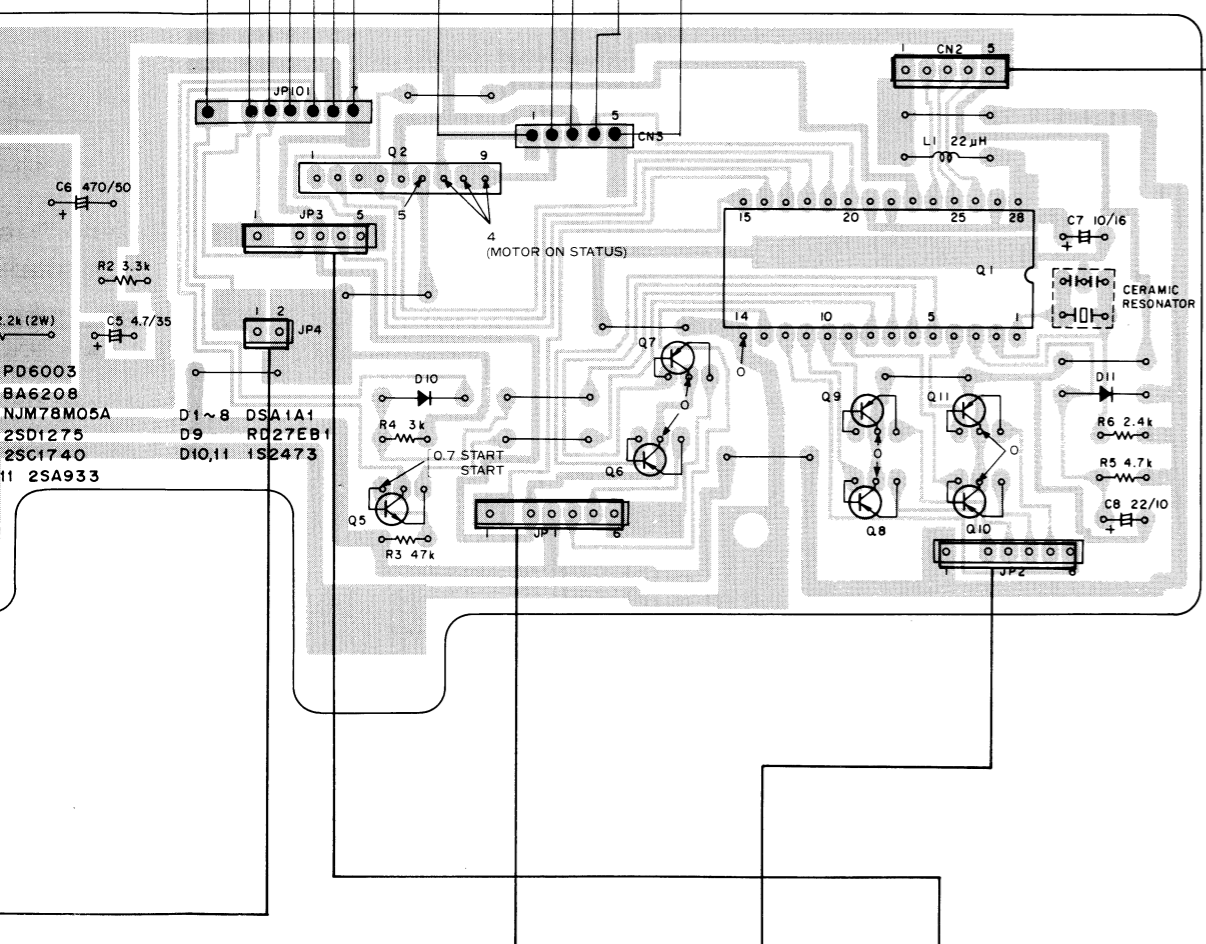
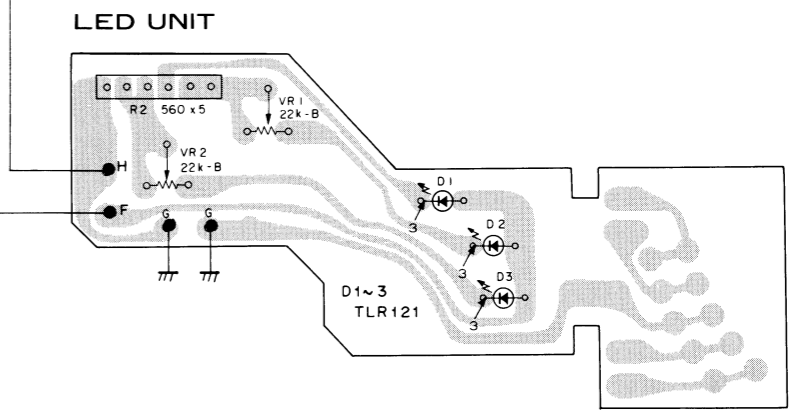
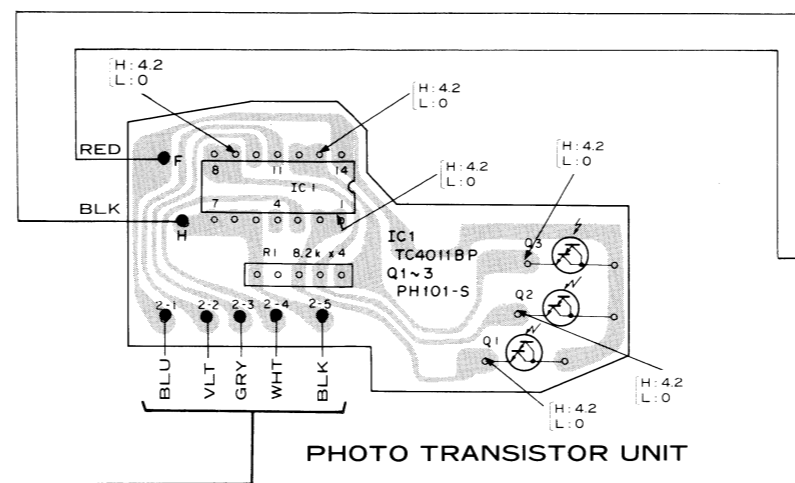
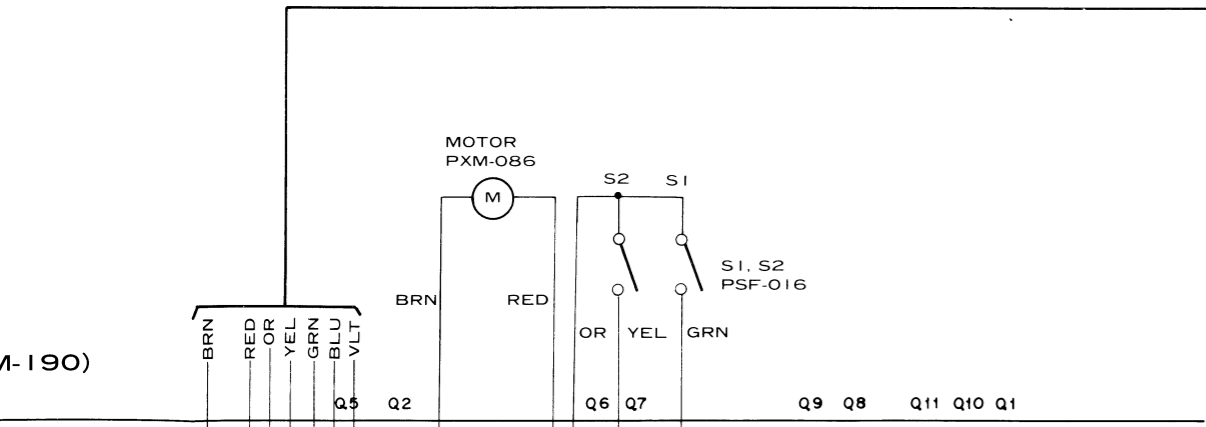

MOTOR (PXM-144)

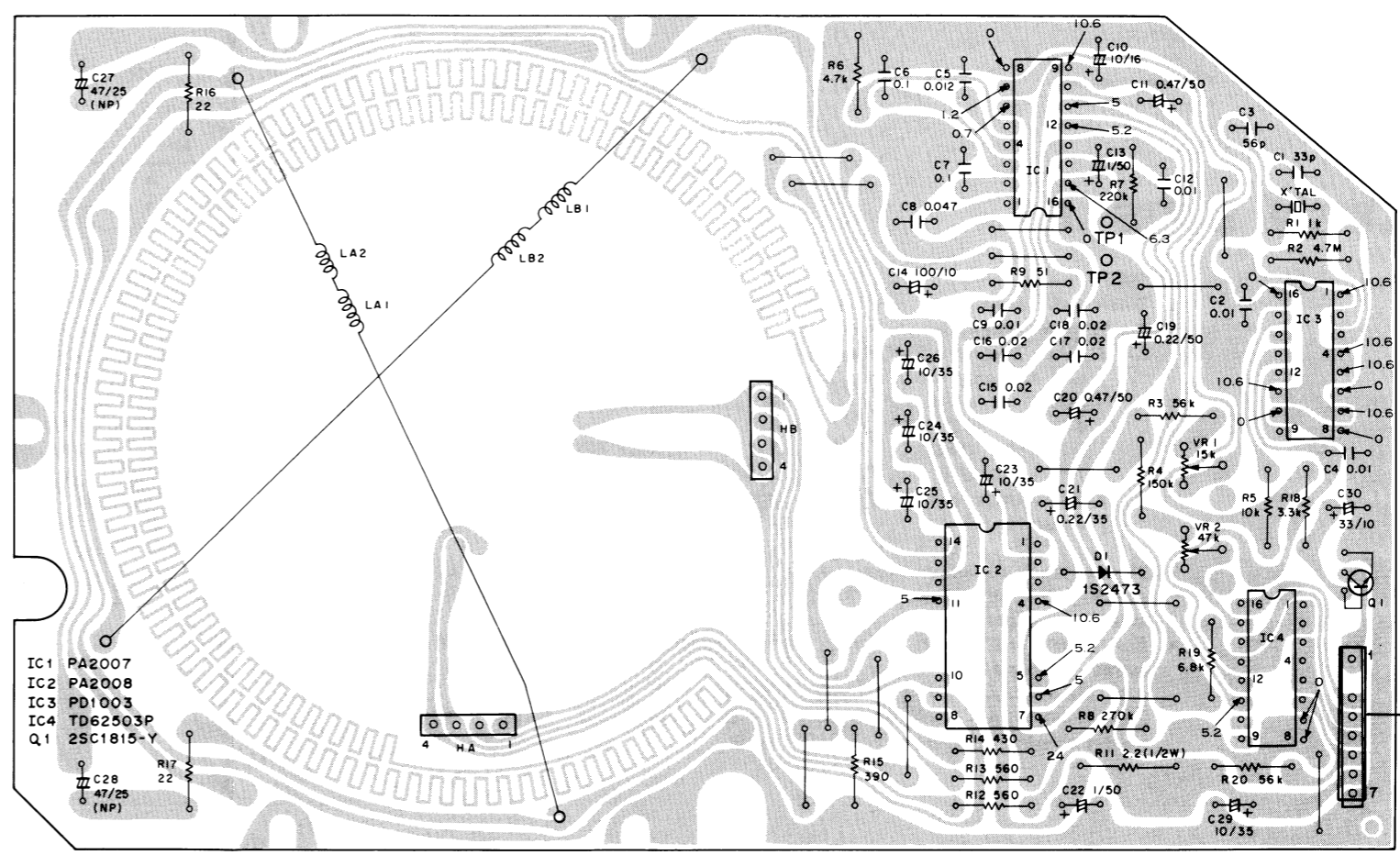

OPERATION (B) UNIT

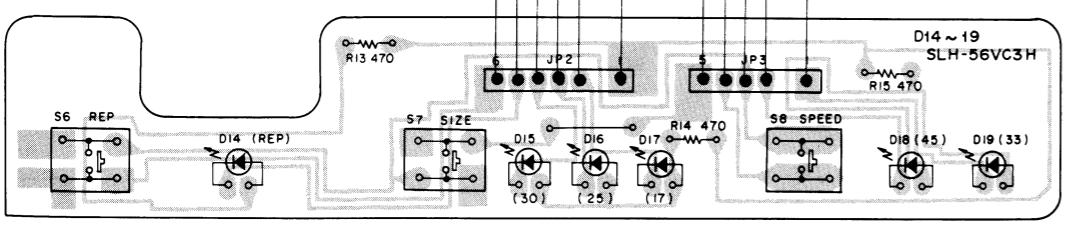

A B C D

8. SCHEMATIC DIAGRAM

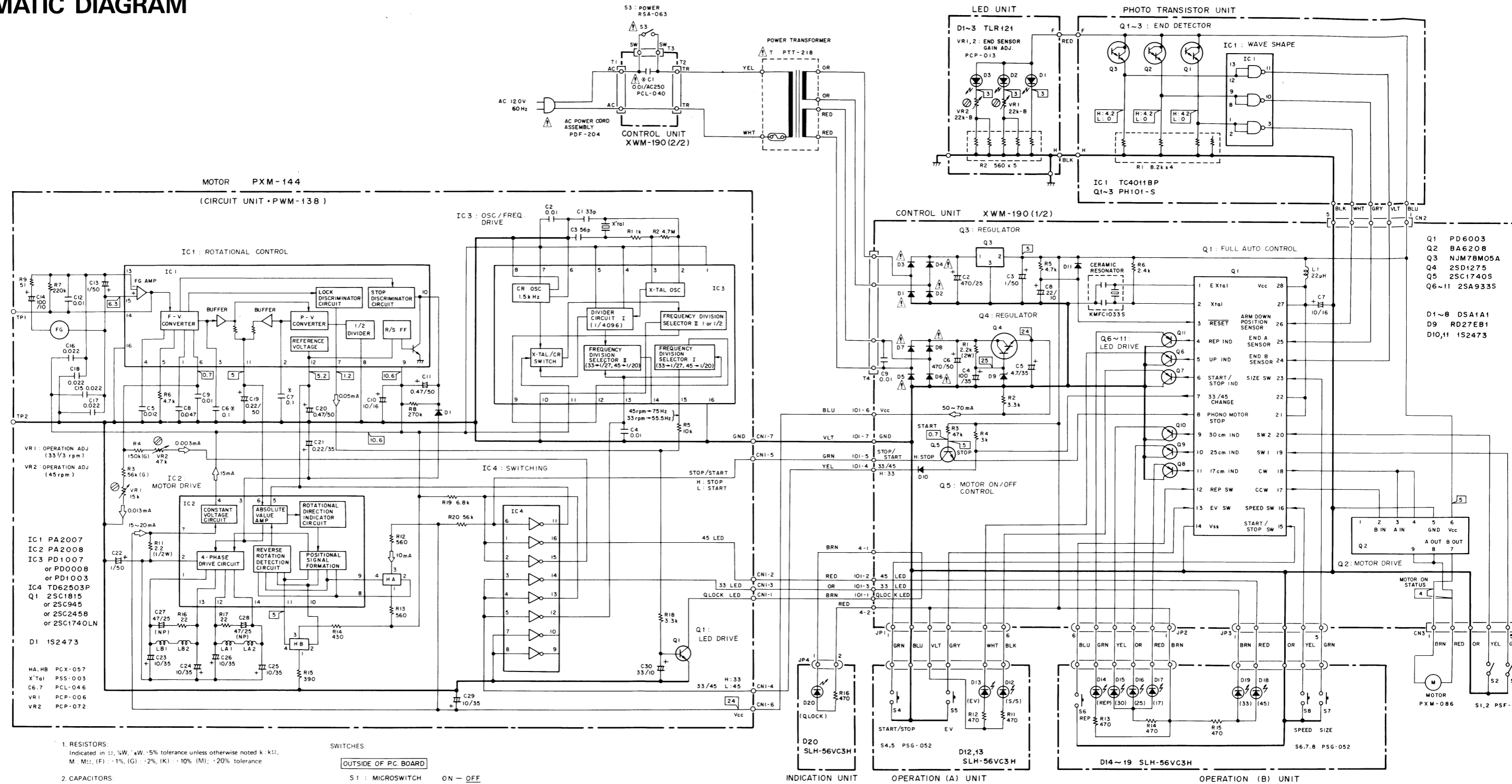

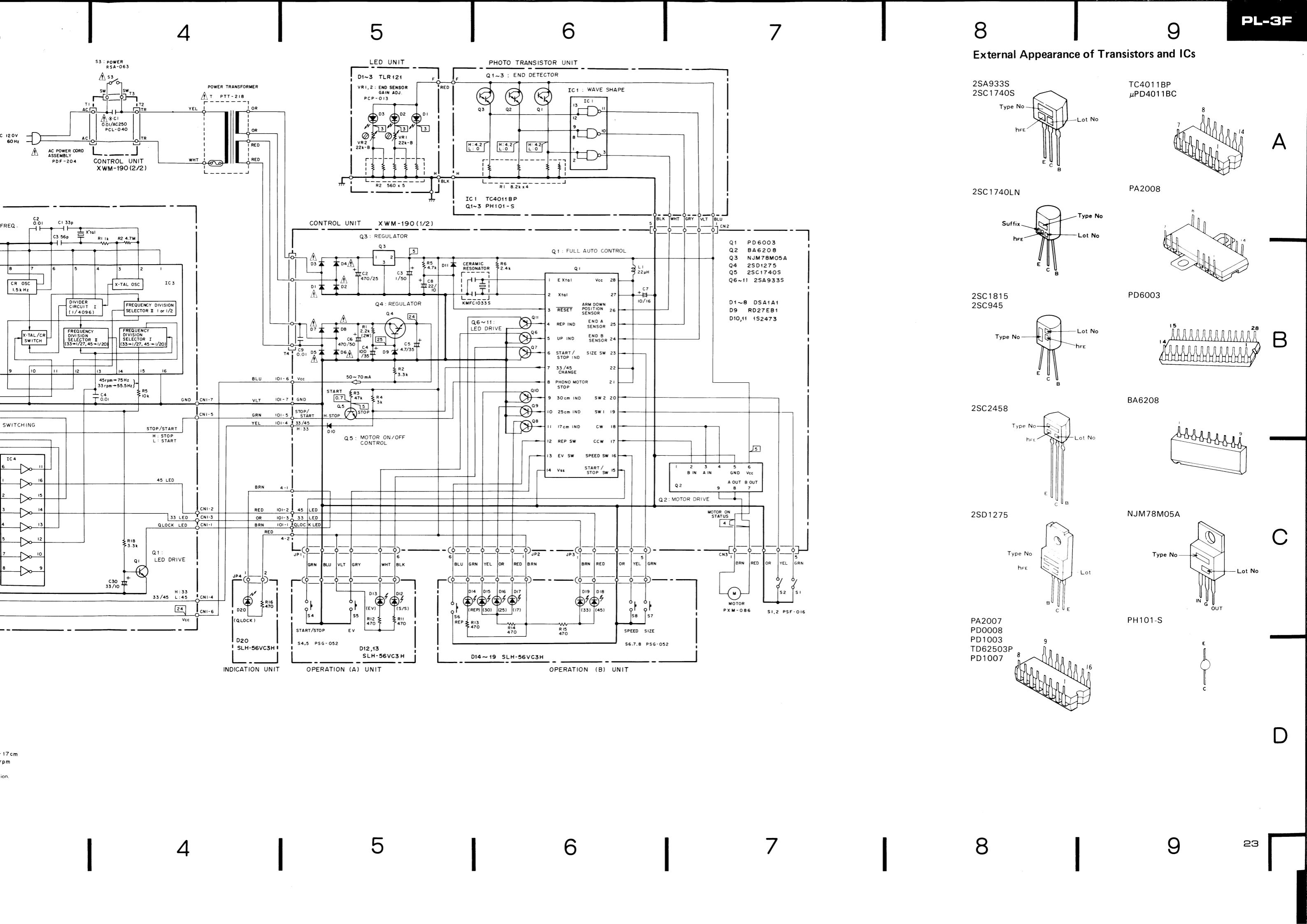

External Appearance of Transistors and ICs

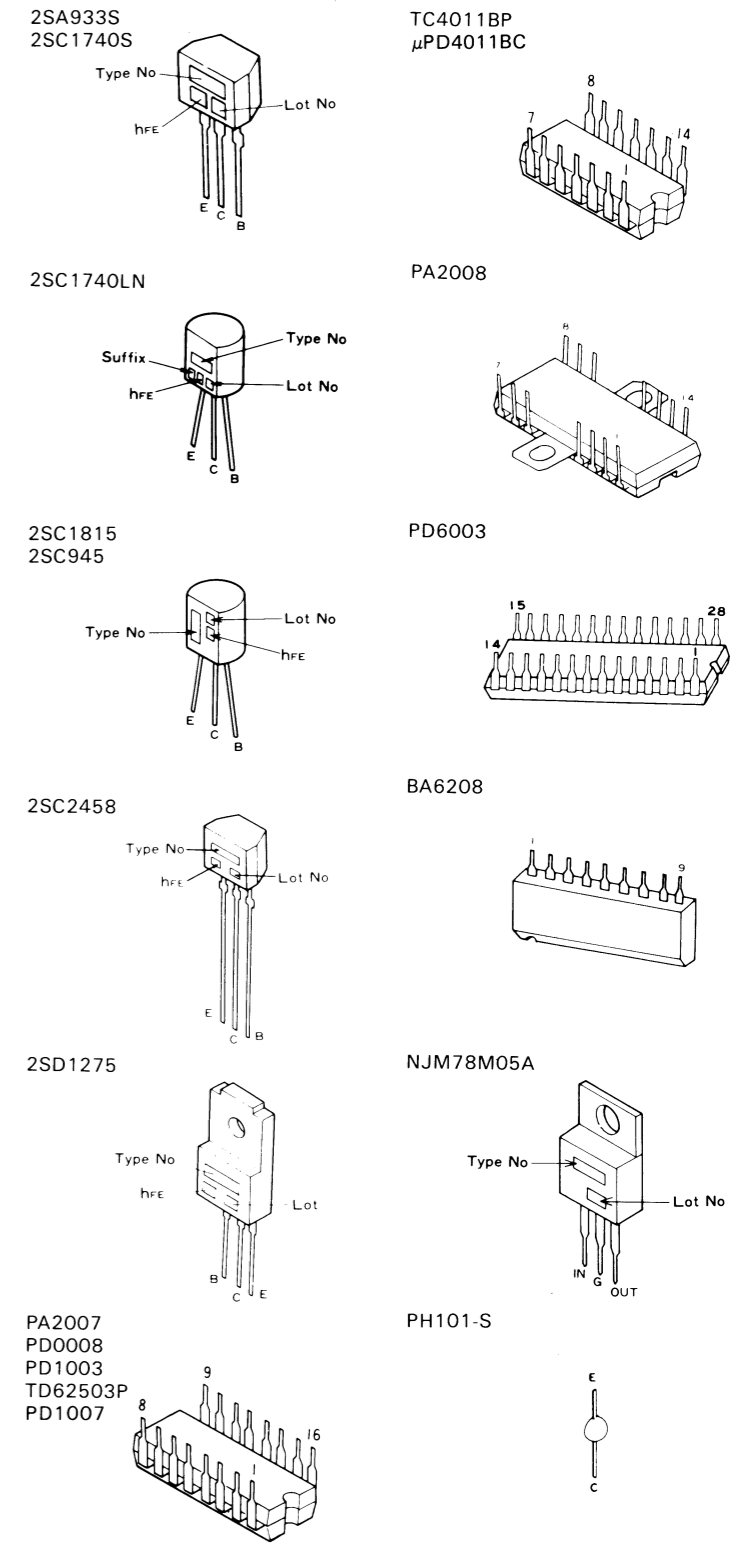

A

B

C

D

17cm
rpm
ion.

9. PACKING

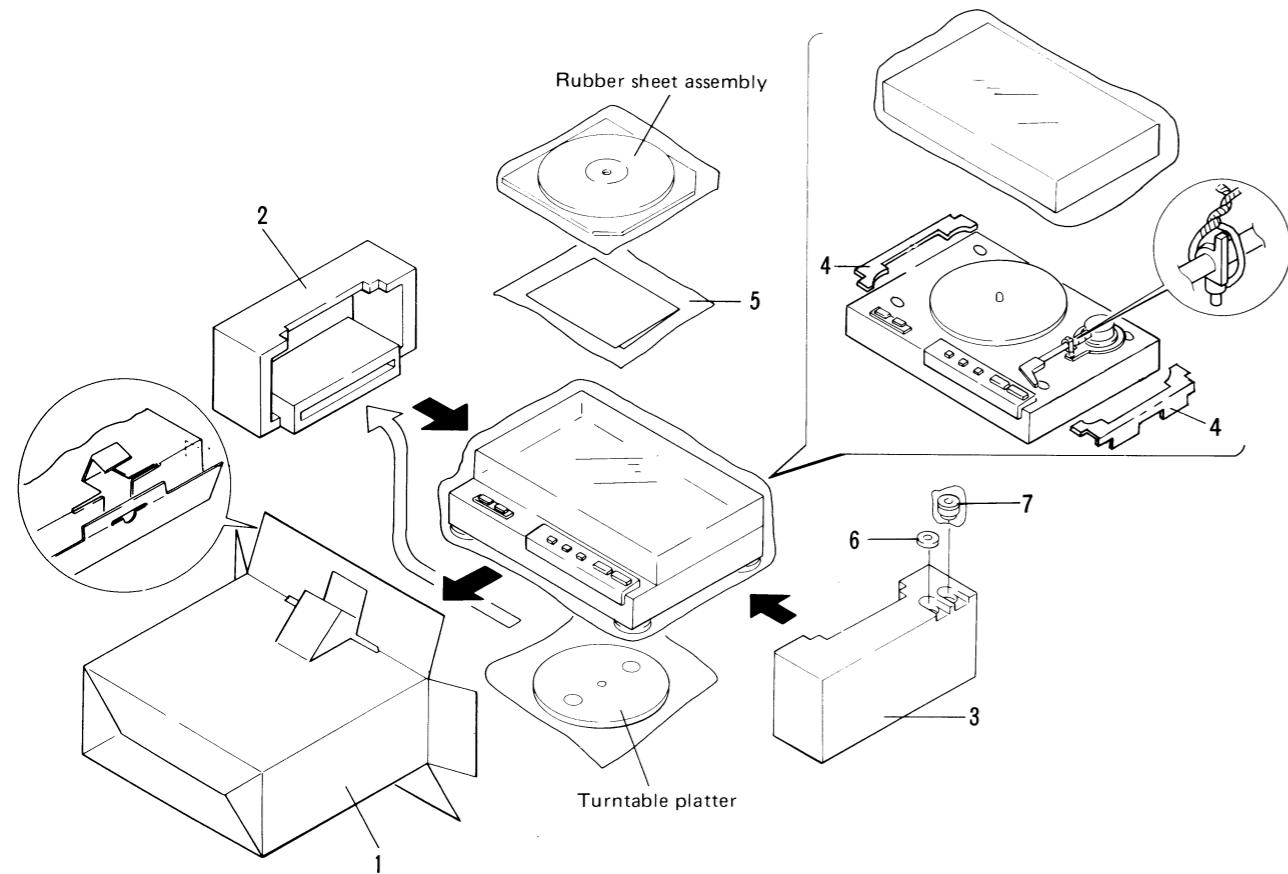

Parts List of Packing

Mark	No.	Part No.	Description	Mark	No.	Part No.	Description
	1.	PHH-195	Packing case		6.	N93-603	45 adaptor
	2.	PHA-154	Protector (L)		7.	PXB-617	Weight assembly
	3.	PHA-155	Protector (R)			PXB-125	Accessory screw assembly
	4.	PHC-110	Dust cover spacer			PBA-530	Cartridge mounting screw Cartridge mounting screw Cartridge mounting screw Cartridge mount nut Cartridge washer
	5.	PRB-296	Operating instructions			PBA-531	
						PBA-532	
						PBN-902	
						B23-642	

10. BLOCK DIAGRAM

PHONO MOTOR CONTROL SECTION

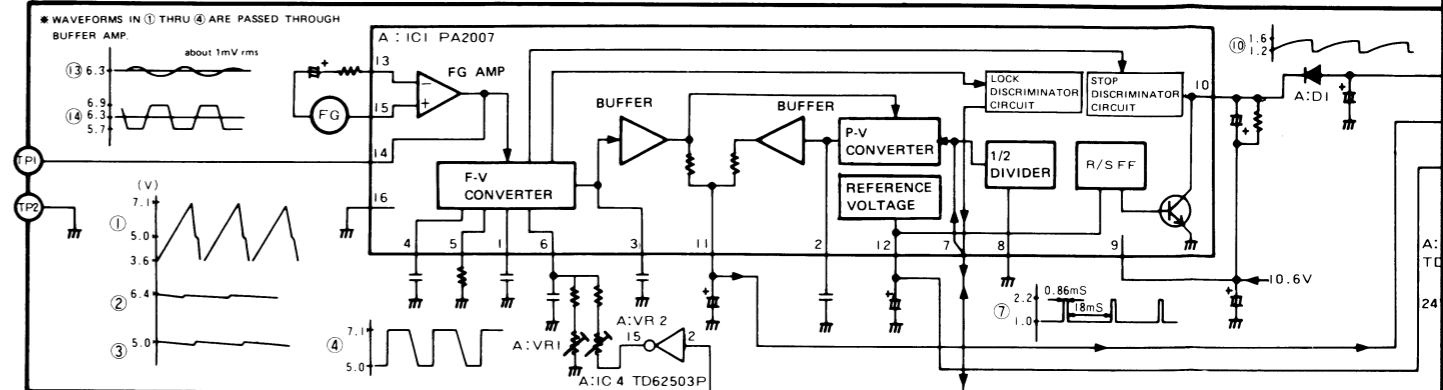

STANDARD FREQUENCY: 33 1/3 rpm → 55.5 Hz, 45 rpm → 75 Hz. QUARTZ LOCK SIGNAL: 33/45.

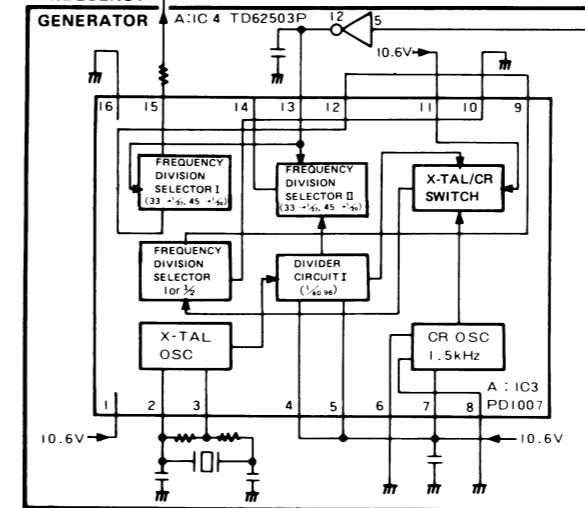

TOPEARM SENSOR SECTION

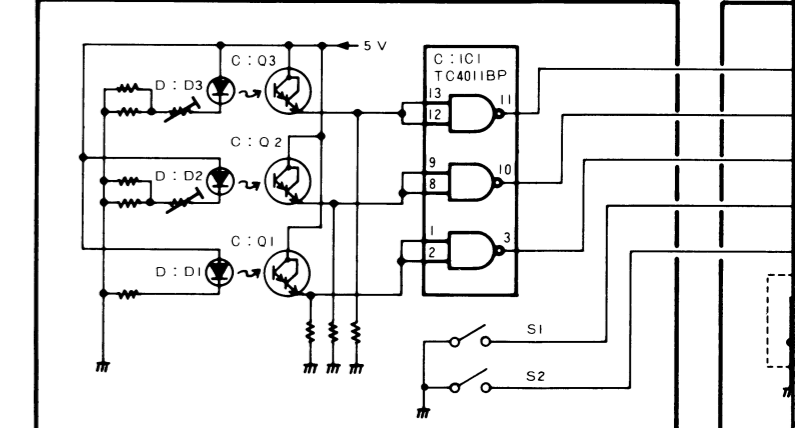

POWER SUPPLY SECTION

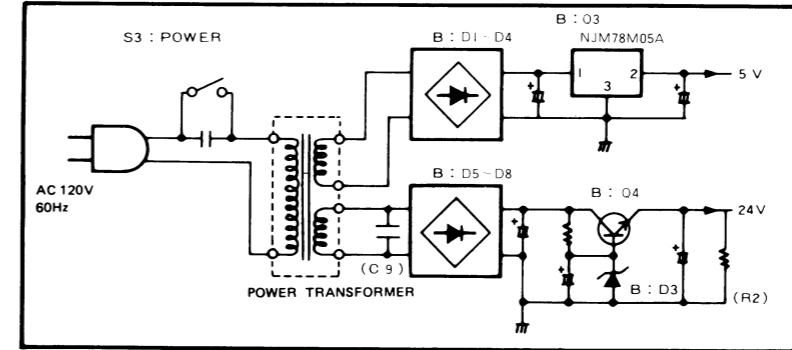

CONTROL SWITCH SECTION

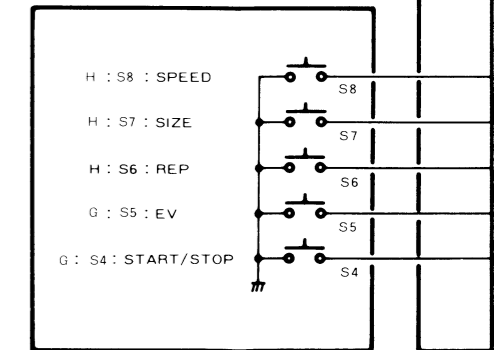

SWITCH
 S 1 : MICRO (TONEARM MECHANISM) ON OFF
 S 2 : MICRO (TONEARM MECHANISM) ON OFF
 S 3 : POWER ON OFF
 S 7 : SIZE 30cm 25cm 17cm
 S 8 : SPEED 33 1/3 rpm 45 rpm
 S 6 : REPEAT ON OFF
 S 5 : ARM ELEVATION UP DOWN
 S 4 : START/STOP ON OFF
 The underlined indicates the switch position.

NOTE:
 The letters preceding the circuit component symbols denote the unit where the component is located.
 A: MOTOR ASS'Y (PXM-144)
 B: CONTROL UNIT (XWM-190)
 C: PHOTO-TRANSISTOR UNIT
 D: LED UNIT
 E: INDICATION UNIT
 G: OPERATION (A) UNIT
 H: OPERATION (B) UNIT

10. BLOCK DIAGRAM

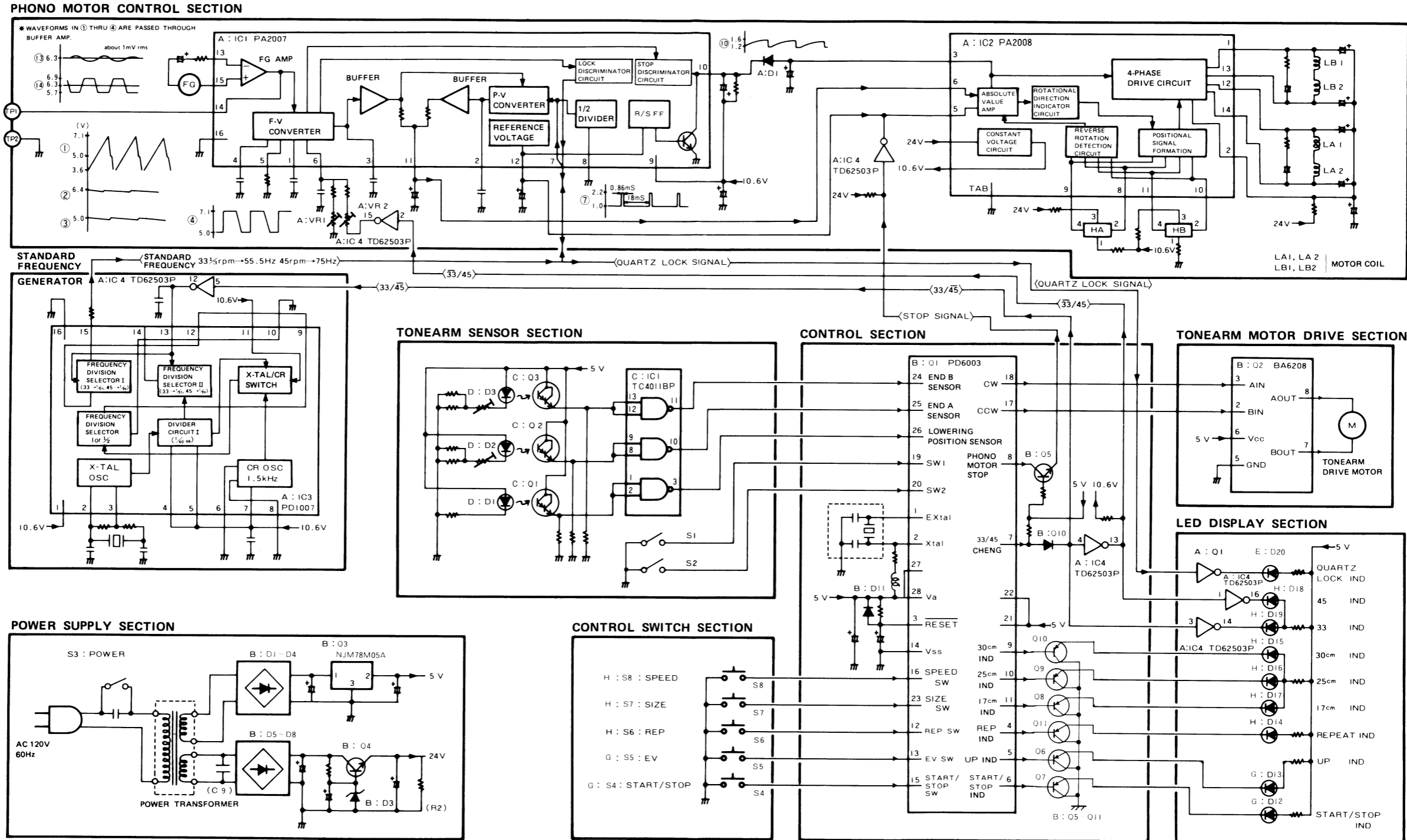

- SWITCH**
- | | | | |
|---------------------------------|-----------------|---------------------|---------|
| S 1 : MICRO (TONEARM MECHANISM) | ON OFF | S 5 : ARM ELEVATION | UP DOWN |
| S 2 : MICRO (TONEARM MECHANISM) | ON OFF | S 4 : START/STOP | ON OFF |
| S 3 : POWER | ON OFF | | |
| S 7 : SIZE | 30cm 25cm 17cm | | |
| S 8 : SPEED | 33 1/2rpm 45rpm | | |
| S 6 : REPEAT | ON OFF | | |
- The underlined indicates the switch position.

NOTE:
 The letters preceding the circuit component symbols denote the unit where the component is located.
 A: MOTOR ASS'Y (PXM-144)
 B: CONTROL UNIT (XWM-190)
 C: PHOTO-TRANSISTOR UNIT
 D: LED UNIT
 E: INDICATION UNIT
 G: OPERATION (A) UNIT
 H: OPERATION (B) UNIT

11. MECHANISM DESCRIPTIONS

To facilitate understanding the operation of the PL-3F, the total unit may be broken down into blocks consisting of the tonearm drive mechanism, the sensing mechanism serving to sense lead in and lead out positions of the tonearm, the control section consisting of the full-auto control IC PD6003, and the motor section functioning to drive the turntable platter. →

→ The operational and functional relationship between each block is quite complex, so in order to understand total system operation, it is first necessary to thoroughly understand the operation and function of each block, then carefully study their interrelationships.

This manual covers the subject in that order. First, the operation and function of each block will be described, then a timing chart is presented to clarify block relationships.

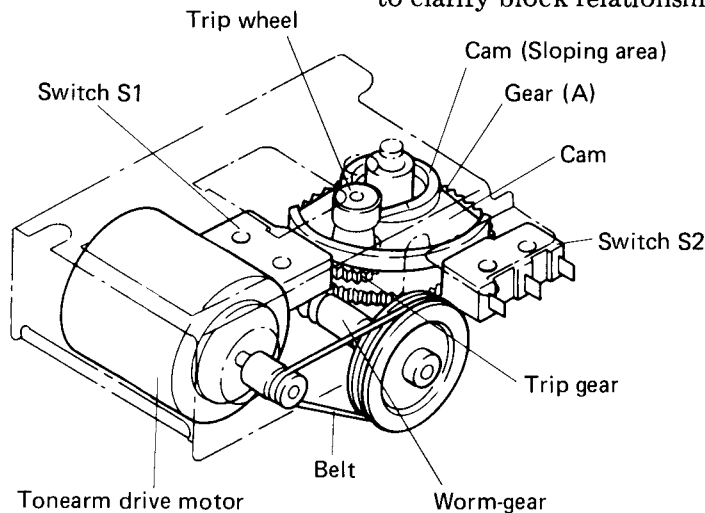

Fig. 11-1 Tonearm drive mechanism

4.1 TONEARM DRIVE MECHANISM

1. The tonearm drive mechanism consists of the tonearm drive motor, worm-gear, gear (A), gear (B), trip gear, trip wheel, cam, switch S1, and switch S2. (Fig. 11-1)
2. The gear cluster is shown in Fig. 11-2. When the cam is held immovable and gear (A) is rotated in a counterclockwise direction, a small amount of friction is felt, but gear (B) and trip gear also rotate. Note that rotation of the trip gear also rotates the trip wheel. (Fig. 11-3) Also note that when the cam is free to rotate, friction will cause it to rotate in the same direction as gear (A) and (B).
3. Refer to Fig. 11-4. The elevation shaft contacts the sloping area located around the center shaft of the cam. Also note the position of the cam at this time. This is the position the mechanism will be in prior to starting up the unit. The tonearm will be on the arm rest, and arm-elevation will be in the DOWN position.

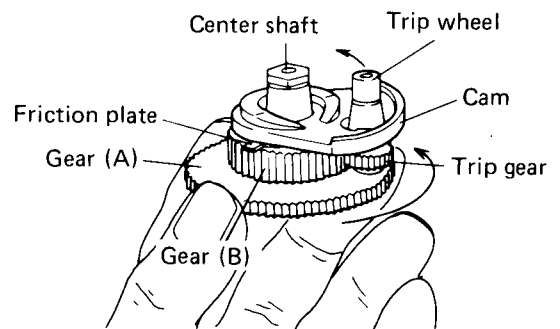

Fig. 11-2 Gear cluster

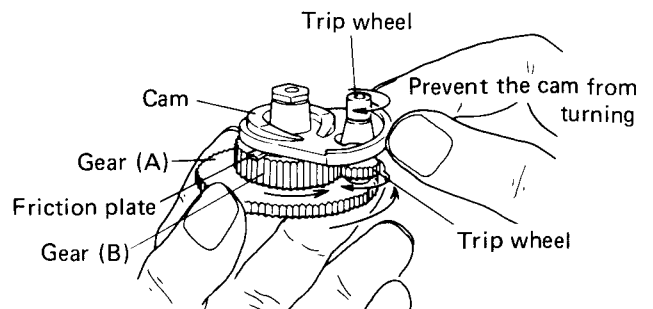

Fig. 11-3 Gear cluster operation

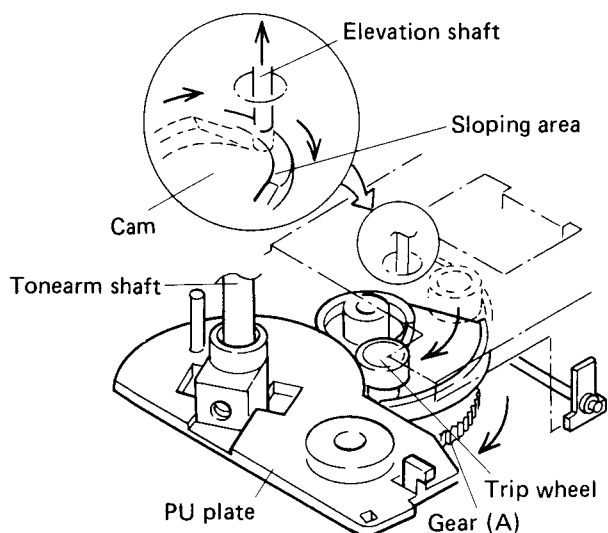

Fig. 11-4 Lead in operation

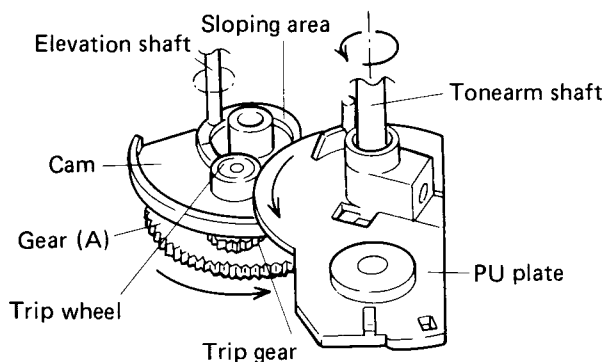

Fig. 11-5 Return operation

4. Turn the worm gear by hand imitating what would occur if the START/STOP button were depressed causing the motor to rotate the gear. Worm gear rotation causes gear (A) to rotate, and the gears shown in Fig. 11-2 and 11-3 of item 2 above all turn in a clockwise direction.
5. The elevation shaft raises as the gear/cam assembly rotates, and this in turn causes the tonearm to raise. The two switches, S2 and S1 are also turned OFF.
6. As the assembly rotates further, the trip wheel and PU plate attached to the tonearm shaft come into contact, creating the same condition as occurred in item 2 where the cam was held in an immovable position. Continued rotation of the trip wheel causes the PU plate attached to the tonearm shaft to turn.
7. Rotation of the PU plate moves the tonearm to the point specified by the sensing and control mechanisms (covered in the following paragraphs). When the tonearm reaches that

specified point, the motor reverses itself, and the cam switches S1 and S2 ON in sequence. Arm-elevation goes to the DOWN position and playback starts.

8. In practice, each of the above operational steps are controlled either directly or indirectly from the control section or by the forward or reverse rotation of the motor. The control section picks up its operational cues by detecting the ON or OFF status of switch S1 and S2, and these switches are controlled by the movement of the mechanism positioning the cam.

11.2 SENDING MECHANISM

As shown in Fig. 11-6, the shutter fixed to the tonearm is positioned to travel in the space between the phototransistors and LEDs mounted on

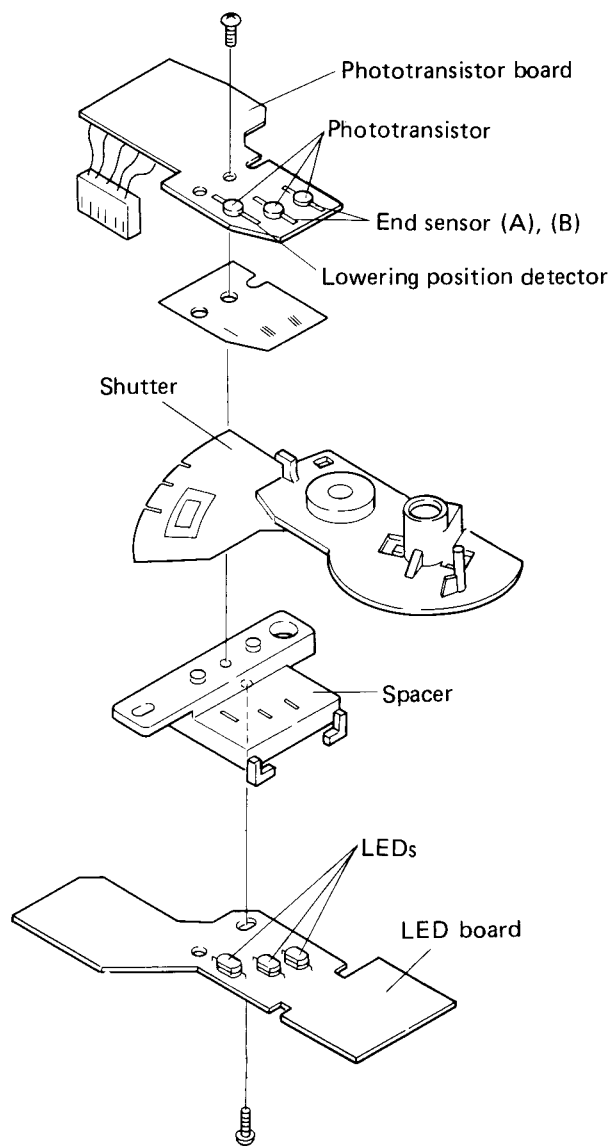

Fig. 11-6 Sensing mechanism

their respective boards. The shutter has three 0.7mm slits cut out of its outer circumference at the position the outer edge of a 30cm, 25cm, or 17cm record disc would be located. The slit, or opening located inside of those three slits is the end sensor slit (Fig. 11-7).

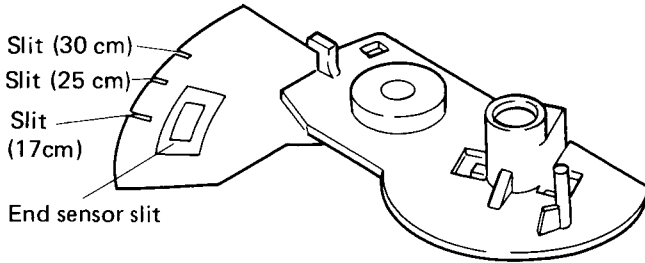

Fig. 11-7 Shutter

■ Lowering Position Detector

1. This unit is mechanically designed to allow the shutter to pass between two boards mounting the sensing elements or photocoupler. The photocoupler consists of an LED and phototransistor.
2. The shutter moves with the tonearm, and a signal is transmitted to the control section by the light emitted from the LED (normally interrupted by the opaque portion of the shutter) being passed through the 30cm, 25cm, or 17cm slit and triggering the phototransistor ON.

■ End Sensor

1. As the tonearm travels toward the inside of the record disc and reaches the end sensor zone (end sensor slit), the light transmitted by the LED is passed through the end sensor slit and turns the phototransistor ON, then OFF. This causes the pulse signal transmitted by end sensor A and B to go 90° out of phase.
2. The pulse frequency is compared with the rotational speed (movement) of the tonearm, and then sent to the control section as the record disc lead-out groove sensor signal.

■ Arm Rest Position Sensor

1. When the three sensors consisting of the lowering position sensor and end sensor (A) and (B) are all simultaneously picking up transmitted light, control determines that the tonearm is at the arm rest position.
2. This status is used to control starting and stopping of the turntable motor during manual operations, or, in the auto-return mode, simply perceives that the tonearm has returned to the arm rest.

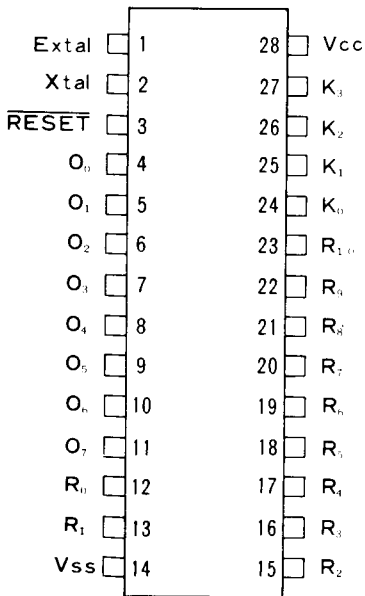

IC PD6003 pins

Pin	Function	Timing	Pin	Function	Timing
O ₁₁	Repeat display output		R ₅	CW rotation output	
O ₁	EV-UP display output		R ₆	SW1 input	—
O ₂	START-STOP display output		R ₇	SW2 input	—
O ₃	Speed selector output		R ₈		
O ₄	Turntable motor stop output		R ₉		
O ₅	30cm display output		R ₁₁	Size selector switch input	
O ₆	25cm display output				
O ₇	17cm display output		K ₁₁	End sensor B input	—
			K ₁	End sensor A input	—
R ₀	Repeat switch input		K ₂	Lowering position sensor input	
R ₁	EV switch input		K ₃		
R ₂	START-STOP switch input				
R ₃	Speed selector switch input				
R ₄	CCW rotation output				

PD6003 Pin Function Table

Fig. 11-8 PD6003

11.3 CONTROL SECTION

The functions of the full-auto control IC PD6003 are described in this section. The table shown in Fig. 11-8 lists the function performed by each pin of PD6003. Please refer to this table as the detailed explanation progresses.

1. When the tonearm is at the arm rest position, pressing the START/STOP button causes the turntable motor to start rotating and illuminates the LED built into the START/STOP button and the EV UP display LED. At the same time the tonearm drive motor moves the tonearm toward the lead in groove of the record.
2. The tonearm drive motor continues rotating until it reaches the point where the signal from the lowering position sensor is picked up. When that point is reached, the drive motor is reversed, lowering the tonearm.
3. End sensor A and B is used to detect the end of playback, but if the START/STOP button is depressed during playback, the tonearm drive motor starts rotating in the return direction and tonearm return operation is started. When the tonearm reaches the point directly above the arm rest, the tonearm drive motor starts rotating in the reverse direction and lowers the tonearm on the arm rest.
4. If the operation in the above step is carried out with the repeat switch ON, the tonearm again will return to the lead in groove. If the repeat switch is OFF, the turntable motor will stop at this point.

11.4 ACTUAL OPERATION (PLAYBACK OF A 33 rpm, 17cm RECORD DISC)

Automatic Lead in

1. Depress the button and turn the power switch ON. Set the speed for the record to be played (33 rpm). When the 33 rpm button is depressed, an instruction signal from the motor assembly will illuminate the 33 rpm display LED, D19. Next, set the proper size for the record to be played (17cm in this case). When the size selector switch is depressed twice, the 11 pin of PD6003 will go to a low level, and the 17cm display LED, D17 will be illuminated.
2. With the turntable thus set up, depressing the START/STOP button causes the 15 pin of PD6003 to go to a low level. Also 6 pin goes to a low level, illuminating the START/STOP display LED, D12. At the same time, pin 17 goes to a low level and pin 18 goes high,

starting rotation of the tonearm drive motor in the mechanism section.

3. The worm gear is coupled to the rotating motor by belt, and the worm gear turns gear (A) (and cam) in a clockwise direction. The tonearm is lifted by the arm-elevation mechanism, and switch S2 and S1 go OFF.
4. Gear (A) (and the cam) continue rotating until finally, the cam makes contact with the PU plate fixed to the tonearm shaft. When the cam contacts the PU plate, it stops rotating. However, the trip wheel continues rotation along with gear (B).

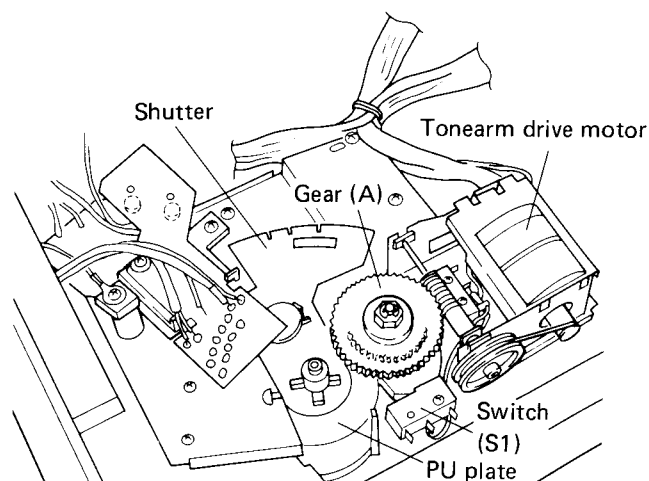

Fig. 11-9 Mechanism section

5. The trip wheel is making contact with the arm rotation stopper, and the rotating trip wheel causes the PU plate to turn. The turning PU plate moves the tonearm toward the center of the platter.
6. As the tonearm moves, so does the shutter attached to the tonearm shaft. The tonearm (and shutter) go past the 30cm and 25cm lowering position until it reaches the 17cm record disc lead-in groove where the third pulse signal from the lowering position sensor (light from LED passes through the slit in the shutter fixed to tonearm shaft turning phototransistor ON) causes the 26 pin of PD6003 to go to a low level. (Pulse signals are also produced at 30cm and 25cm positions.)

7. This causes the PD6003 17 pin to go low, and the 18 pin to go to a high level, and after the tonearm drive motor stops, it commences reverse rotation. As it rotates, the arm-elevation shaft riding on the sloping area of the cam moves down off the slope and playback starts.
8. When the tonearm drive motor rotating in reverse (switch SW1 ON) turns switch SW2 ON, the PD6003 6 pin goes to a high level, extinguishing the START/STOP display LED, D30. The turntable will not go into the auto-stop until the START/STOP display LED is extinguished even though the START/STOP button is depressed. Also, when both the tonearm drive motor and switch SW2 are ON, PD6003 17 and 18 pin both go high, stopping the drive motor.
9. If the tonearm does not move off the arm rest within 8 seconds after the START/STOP button is depressed (tonearm clamped in arm rest), the START/STOP display indicator starts flashing. If this status (flashing) continues for another 11 seconds, the start instruction is cancelled and the tonearm lowers in the arm rest.
10. The elevation -up display LED, D13 illuminates when the START/STOP button is depressed, and when the tonearm moves to the record disc and lowers down, D13 is extinguished. PD6003 senses the first pulse as the 30cm position, the second as the 25cm, and the third as the 17cm record size position. When it determines that the tonearm has reached the proper lowering position, pin 5 goes to a high level, extinguishing the display.

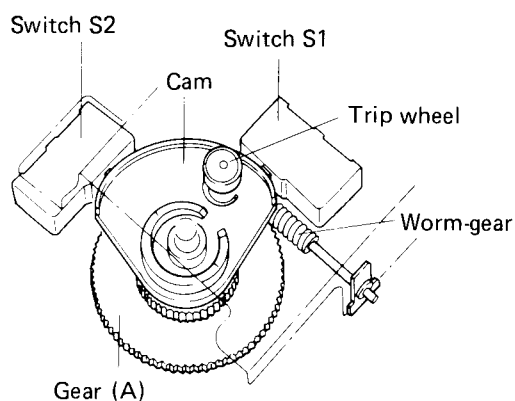

Fig. 11-10 Switch S1, 2 position

■ Arm-elevation UP and DOWN

1. When the arm-elevation switch is depressed during record playback, arm-elevation goes UP and playback is temporarily stopped.
2. When the arm-elevation switch is depressed, the 13 pin of PD6003 goes to a low level. Pin 5 also goes low, and illuminating the elevation display LED, D13.
3. At the same time, pin 17 goes to a low level and pin 18 goes high, starting tonearm drive motor rotation. This causes the cam to turn, and the elevation shaft to ride up on the sloping section of the cam. This action causes the arm-elevation to go to the UP position, stopping record playback.
4. The tonearm drive motor continues to move the cam until the position is reached where S1 is turned OFF (tonearm still in UP position).
5. To restart playback, the arm-elevation switch is depressed again. This causes the 13 pin of PD6003 to go to a low level. The 5 pin goes high, extinguishing the elevation display LED, D13.
6. At the same time, pin 17 goes high and pin 18 goes low, causing the tonearm drive motor to rotate in an opposite direction of that in the UP position. As the cam turns, the elevation shaft drops down off the slope, lowering the tonearm and starting playback again.
7. The tonearm drive motor continues to move the cam until the position is reached where S2 is turned ON (tonearm still in DOWN position).

For manual playback operation, depress the arm-elevation switch to raise the tonearm up off the arm rest (UP), then move it to the desired point over the record by hand. Depressing the arm-elevation switch again will then lower (DOWN) the tonearm onto the record. Operationally, this follows the sequence listed in items 2 through 7 above.

Also during manual play, when the tonearm is manually moved toward the center of the record (off the arm rest), the platter commences rotation. When the tonearm is moved off the arm rest, PD6003 26 pin (signal pin from lowering position sensor) goes to a high level, and the 8 pin goes to a low level, starting the motor rotation.

■ Auto-return

1. When record playback is over, the tonearm stylus goes from the band of audio grooves into the lead out groove, and the pulse width of the signal output from end sensor A and B become more narrow. This informs PD6003 that record playback has ended.

The phase of the pulse from end sensor A and B is set so that B leads A by 90°, however this phase offset is not used for detection of the end of playback, but to prevent any unintentional operations from sources such as record disc eccentricity.

2. When playback completion is detected, PD6003 pin 17 goes to a high level and pin 18 goes low, starting the tonearm drive motor rotating. As rotation moves the cam, the slope causes the arm-elevation to go UP, raising the tonearm.
3. As the cam continues rotating, it strikes the PU plate. This stops cam movement, but the trip wheel continues rotating and turns the PU plate. This results in the tonearm being returned to a position above the arm rest.
4. At this position, light strikes the lowering position detector and end sensor A and B (all three at once), and pin 24, 25, and 26 of PD6003 go to a low level.
5. One to two seconds later, PD6003 pin 17 goes low and pin 18 goes high, and after the tonearm drive motor stops, it reverses rotation and sends the arm-elevation back down the cam slope. This lowers the tonearm on the arm rest ending playback.
6. At the same time, the cam turns switch S1 ON (switch S2 is already ON). When both switches come ON, both pin 17 and 18 (PD6003) go to a high level, stopping the tonearm drive motor. Also, when the tonearm reaches the arm rest position, pin 8 goes high, lowering the tonearm and causing pin 5 to go high. This causes the platter to stop rotating and extinguishes the elevation-up display LED, D13.

■ Auto-stop

1. When it is desired to stop record playback in the middle of the record, depress the START/STOP button. As the START/STOP button is depressed, PD6003 pin 15 goes to a low level. Pin 17 goes high and pin 18 goes low, starting rotation of the tonearm drive motor. Rotation causes the arm-elevation to ride up on the slope of the turning cam raising the tonearm.
2. Also pin 6 goes to a low level, thereby illuminating the START/STOP display LED, D12. From here the operation is the same as that for auto-return (above), items 3 through 6.
3. The START/STOP display LED, D12 are extinguished by the tonearm drive motor reversing rotation and turning switch S1 ON and sending PD6003 pin 6 to a high level.

■ Auto-repeat

1. To repeat playback of the same record, depress the repeat button. This causes PD6003 pin 12 to go to a low level. At the same time, pin 4 also goes low, illuminating the repeat display LED, D14.
2. When the repeat button has been depressed, after autoreturn operations have returned and lowered the tonearm on the arm rest, the unit again goes into autolead in operations and continues playback. (The platter motor continues to rotate.)

12. CIRCUIT DESCRIPTIONS

12.1 SIMPLE SIGNAL PATH

The PL-3F motor drive circuit consists of the control IC PA2007, reference phase generator IC PD1007, motor drive IC PA2008, and IC TD62503P functioning to produce the various operational switch signals.

The signal picked up from the speed sensor section is amplified by the FG amp, then converted to the speed sensor signal voltage (DC) by the F/V converter.

Reference phase voltage is obtained by extracting the reference phase from PD1007 pin 15, passing it through the 1/2 divider, then sending it through the P/V converter to be used as reference phase voltage (DC).

The speed sensor signal voltage and reference phase voltage are each passed through a buffer amp and resistance and combined (compared). The resulting voltage is taken from the IC PA2008 pin 6 and input into the absolute value amp, and is used to control the 4-phase drive circuit motor rotation voltage, maintaining the motor at a fixed speed.

12.2 SPEED SENSOR SECTION

1. The speed sensor board consists of a single printed circuit.
2. Above this, rotates a rotor with 200 magnetized poles on its lower face. Output varies in accordance with the rotational speed of the rotor.
3. The output (frequency) from the speed sensor board is 55.5Hz for 33 1/3 rpm and 75Hz for 45 rpm.
4. The output signal is sent to PA2007 as a balanced input.

12.3 FG AMP

In order to square the waveform of the signal obtained from the speed sensor section (output: 0.5 — 2.0 mV rms) prior to inputting it into the F/V converter, it is amplified 69dB across a bandwidth of 20 to 160Hz.

12.4 F/V CONVERTER

1. Since the rotational speed is detected at a fixed frequency, the frequency must be converted to a voltage (DC). This function is performed by the F/V converter.
2. Previously (in PA2004) this was done by a 2-frequency F/V converter, however, increasing control gain of PA2007 allows a signal-frequency F/V to be used.

3. F/V converter gain does not change even with rpm changes.
4. Switching reference frequency is shown in Fig. 12-1.

When the switch is OFF, speed is set to 33 1/3 rpm, and when the switch is ON, the variable resistor used by 33 1/3 rpm is connected parallel to the 45 rpm variable resistor. The resulting total impedance establishes rotational speed. Thus, each time 33 1/3 rpm is adjusted, 45 rpm must also be adjusted. This arrangement prevents any rotational instability that might result from both switches being temporarily OFF when speed changes are made by switching from 33 1/3 — 45 rpm.

5. Co, Ct, Rt, and Rfv are each connected to ground, but the grounding point is very close to that of PA2007. Also, Rt is a 0.01 μ F ceramic capacitor for noise and oscillation removal, and it is grounded in close proximity to PA2007 too.

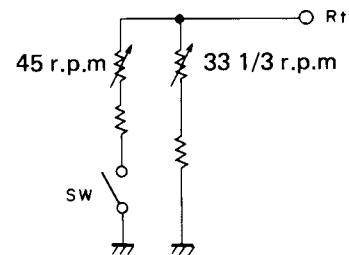

Fig. 12-1 Switching reference frequency

12.5 REFERENCE PHASE GENERATOR IC PD1007

1. When power is turned ON, the X'tal oscillator block generates a 6.144 MHz signal by using the externally connected crystal oscillator.
2. This is reduced to 1.5kHz by divider circuit 1 (1/4096), then this divided signal is input to divider circuit 2.
3. The 1.5kHz signal input to divider circuit 2 is further divided 1/27 for 33 1/3 rpm operation, and 1/20 for 45 rpm, then transmitted from pin 15 to PA2007 pin 7.
33 1/3 rpm: 55.5Hz
45 rpm: 75Hz

12.6 P/V CONVERTER

The P/V converter serves to convert the reference phase taken from the 8 pin (item above) divider to DC voltage.

The reference phase converted into DC voltage is combined (by the buffer amp and resistor) with the DC voltage from the F/V converter (and used for rotation speed) and transmitted from pin 11 as a motor rotation speed control signal to IC PA2008 pin 6, then finally to the absolute value amp (Fig. 12-2).

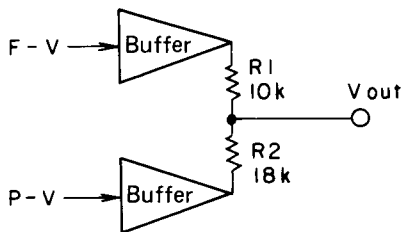

Fig. 12-2 (F-V) + (P-V) circuit

12.7 PHASE-LOCK DISCRIMINATOR CIRCUIT

When phase control is in effect, the output characteristics of the F/V converter appear as in Fig. 12-3. The portion that shows no change in speed when load torque is varied up and down can be considered as the phase-locked area, and the portion where large rotational speed changes occur (as in Fig. 12-4) is outside the phase-locked area. Thus, F/V converter output can be input into an absolute value comparator having an upper and lower threshold. A theoretical diagram of such a circuit is shown in Fig. 12.5.

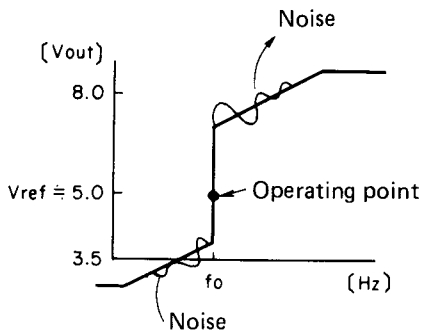

Fig. 12-3 Input/output characteristics

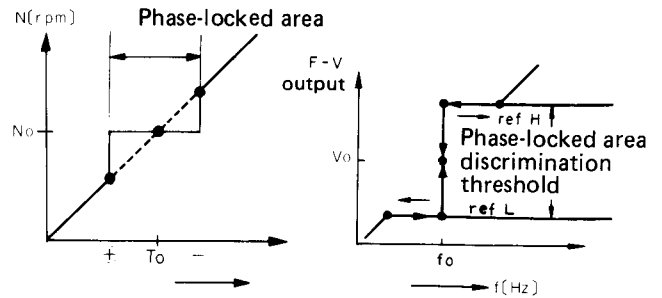

Fig. 12-4 F/V converter output

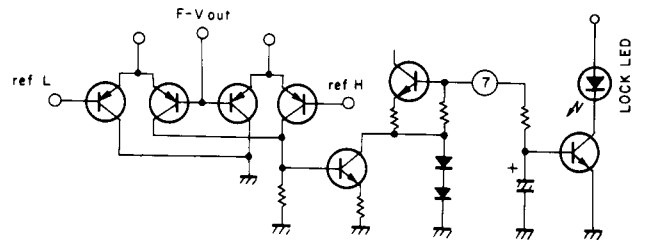

Fig. 12-5 Phase-locked discrimination theoretical circuit

12.8 STOP DISCRIMINATOR CIRCUIT

1. Depressing the START/STOP button of the PL-3F transmits a stop signal generating a reverse torque and applying a brake to the motor. Motor rotation stops almost immediately.
2. The stop discriminator circuit functions to detect low or high rotation speed through the charge/discharge status of capacitors and resistors connected to IC PA2007 pin 10 (To/STOP), and when rotation drops below a certain speed, motor torque is dropped to zero. A theoretical circuit diagram is shown in Fig. 12-6.
3. After that, the platter turns a small amount due to inertia, then stops.

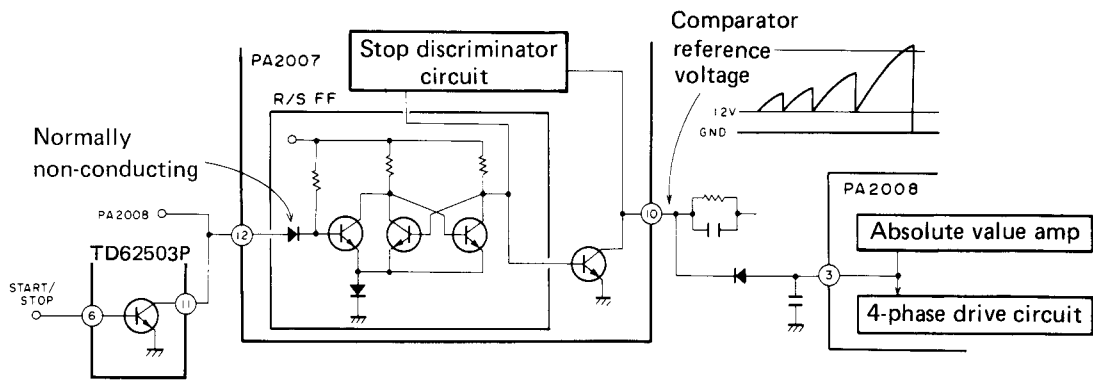

Fig. 12-6 Stop discriminator theoretical circuit

12.9 ABSOLUTE VALUE AMP AND ROTATION DIRECTION INDICATOR CIRCUIT

1. The signal at the 6 pin (control input) is compared with the signal at the 5 pin (reference voltage) and the difference in voltage is used to generate current in the motor winding. The input/output characteristics are shown in Fig. 12-7.
2. The control input is higher than the reference voltage ($V_{ref} 5V$) when the rotation of the platter is higher than specified speed. When this occurs, the absolute value amp sends an indication (instruction) to the rotation direction indicator circuit to generate reverse torque in order to drop the speed of the motor.
3. The control input is lower than the reference voltage ($V_{ref} 5V$) when the rotation of the platter is lower than specified speed. When this occurs, the absolute value amp sends an indication (instruction) to the rotation direction indicator circuit to generate forward torque in order to increase the speed of the motor.

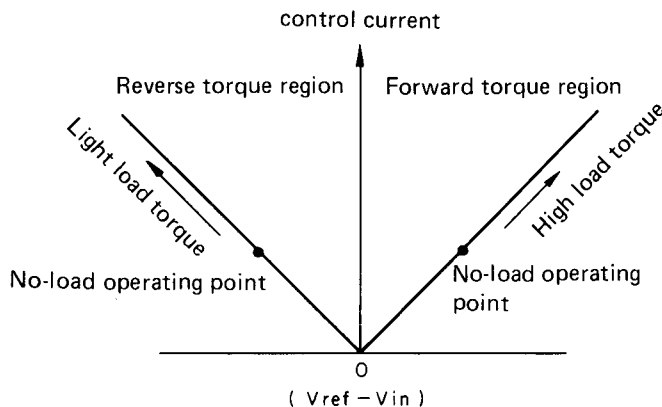

Fig. 12-7 Input/output characteristics

12.10 DRIVE CIRCUIT

1. The HA and HB Hall elements (6 magnetized pole pieces fixed to the circumference of the motor) are attached electrically 90° out of phase with each other. These elements are used to sense the rotational position of the motor.
2. The position sensing signal produced by the Hall elements are each output to the block diagram position signal synthesizing circuit, and their waveforms are shaped as shown in Fig. 12-8.
3. The staircase waves are each input into the block diagram 4-phase drive circuit, and as shown in Fig. 12-8, LA and LB alternate back and forth in a 90° duty cycle (voltage) to turn the motor.
4. LA and LB amplitude is in proportion to the output of the absolute value amp.

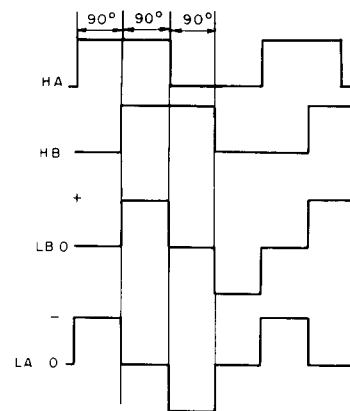

Fig. 12-8 Drive circuit waveforms

12.11 REVERSE ROTATION SENSING CIRCUIT

1. The motor used in the PL-3F is the dual-direction drive circuit type, and if manually forced in the reverse direction, it will continue to apply a forward torque in an attempt to restore forward rotation as long as it does not exceed specified rotation speed.
2. However, when reverse rotation exceeds 45 or 33 1/3 rpm, the rotation direction indicator circuit detects this as an overrun in the forward direction and applies reverse torque in an attempt to bring it to specified rotation speed.
3. Reverse torque applied to the platter already rotating in reverse will further increase the speed and the turntable will run out of control.
4. The reverse rotation guard circuit prevents the platter from running out of control.
5. The equivalent circuit of the reverse rotation sensing circuit consists of a D type flip-flop (D input output at Q by CK triggering).

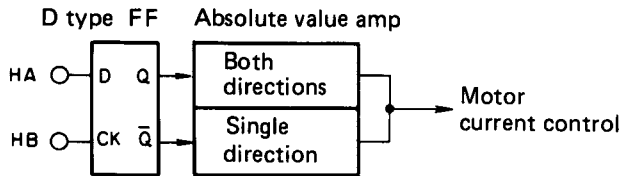

Fig. 12-9 Reverse rotation sensor equivalent circuit

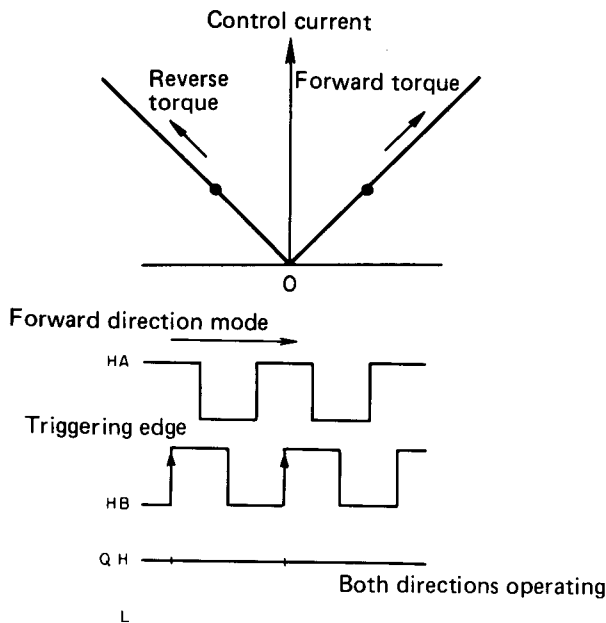

Fig. 12-10 Forward direction mode

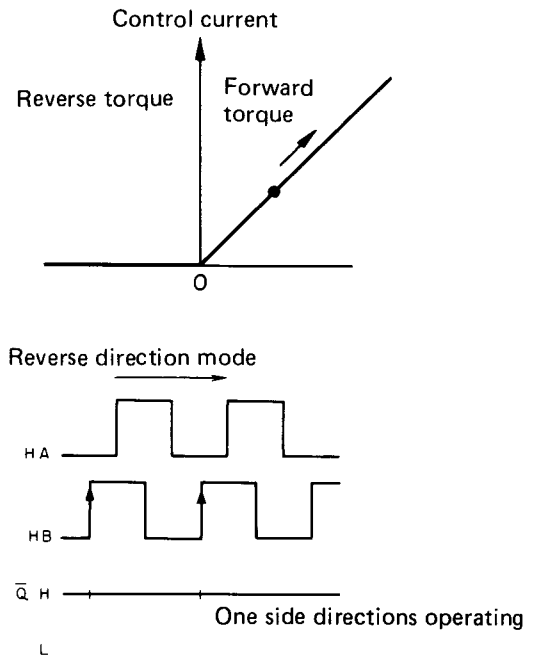
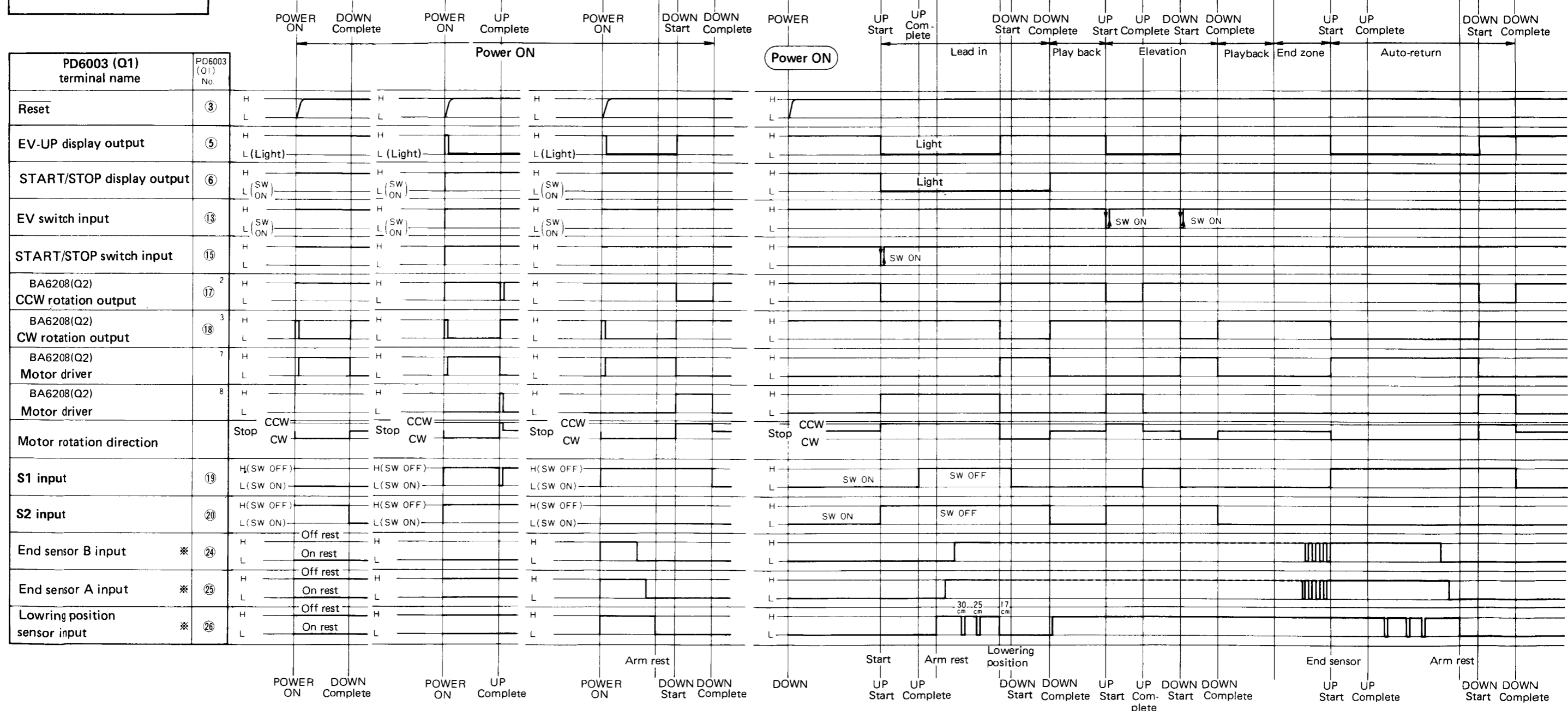
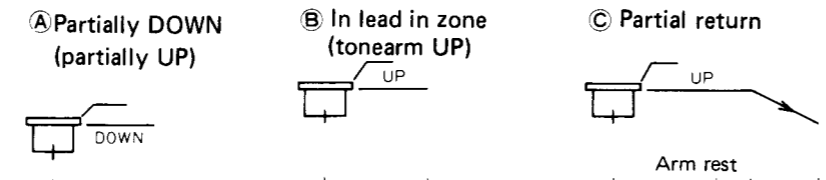

Fig. 12-11 Reverse direction mode

■ TIMING CHART 1

Operational sequence for a single cycle between power ON and auto-
matic stop (full-automatic operation, 17cm record disc).

When power is turned ON, the unit may be in one of four states (A ~ D) depending on the status at the time power was previously turned OFF.



■ TIMING CHART 2

Operational sequence for a single cycle between power ON and automatic stop (full-automatic operation, 17cm record disc).

When power is turned ON, the unit may be in one of four states (A ~ D) depending on the status at the time power was previously turned OFF.

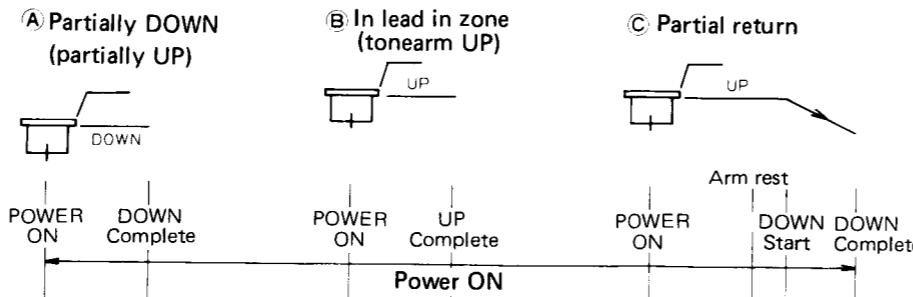

PD6003(Q1) terminal name	PD6003 (Q1) No.	
(Q5 OUT) Platter motor stop output	⑧	H L
Platter motor rotation		Stop
Vcc	⑳	5V 0V
Repeat switch input	⑫	H L (SW ON)
Repeat display output	④	H L (Light)
Size selector switch input	㉓	H L (SW ON)
30cm display output	⑨	H L (Light)
25cm display output	⑩	H L (Light)
17cm display output	⑪	H L (Light)
Speed selector switch input	⑯	H L (SW ON)
Speed selector switch output	⑦	H (33rpm) L (45rpm)
33rpm display		H L (Light)
45rpm display		H L (Light)

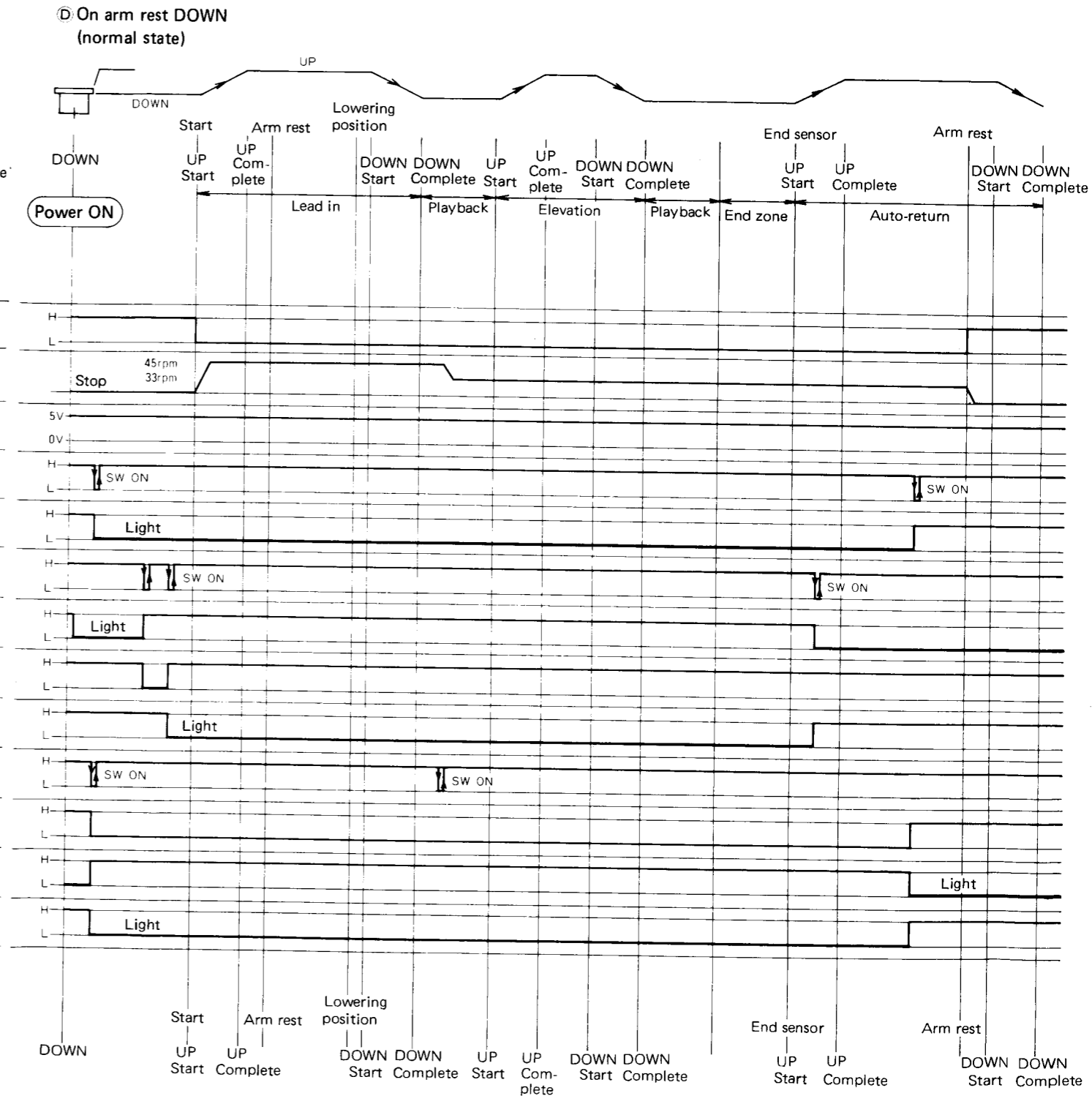
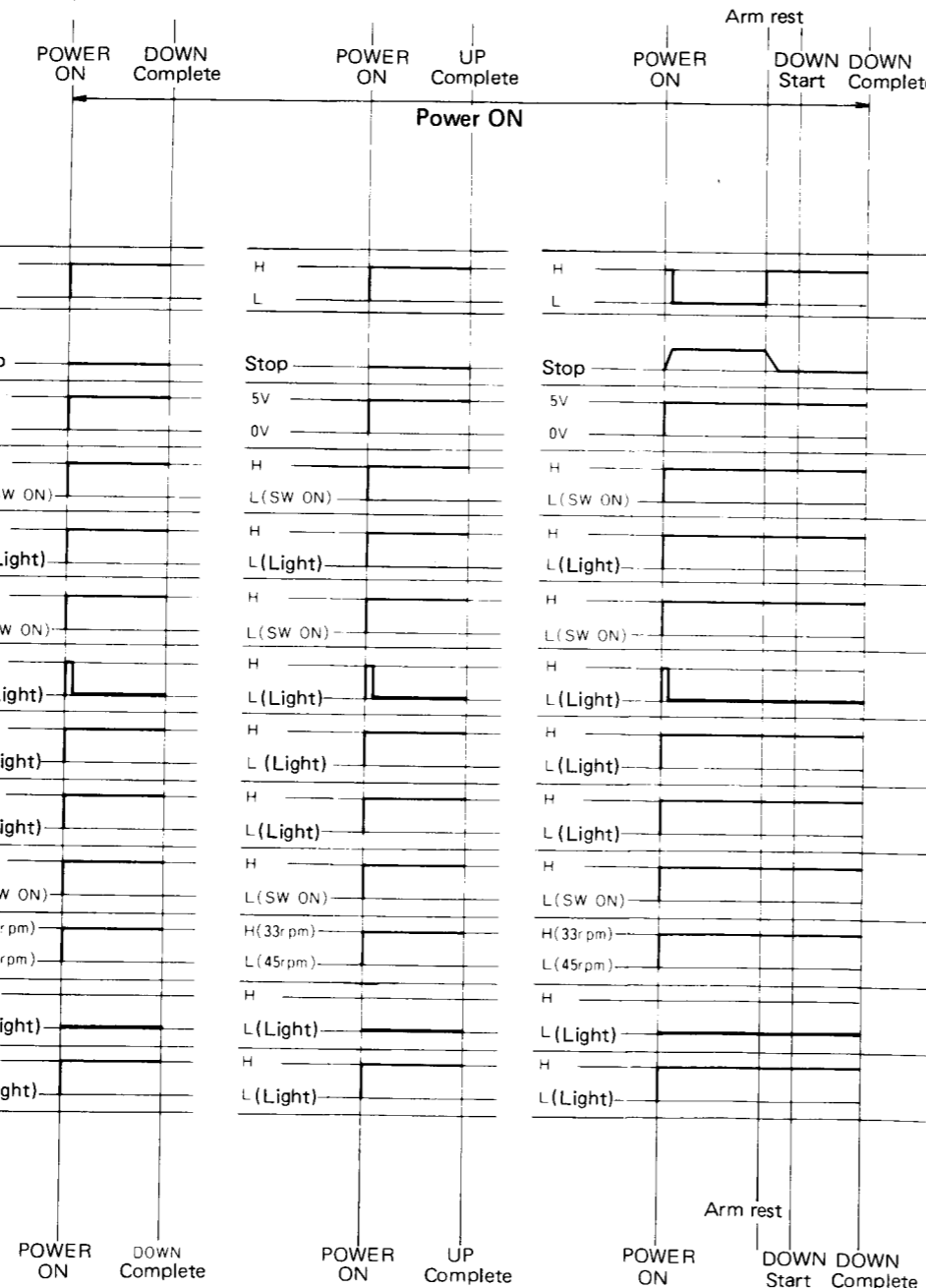

■ TIMING CHART 3

Operational sequence for a single cycle between power ON and auto-matic stop (full-automatic operation, 17cm record disc).

When power is turned ON, the unit may be in one of four states (A ~ D) depending on the status at the time power was previously turned OFF.

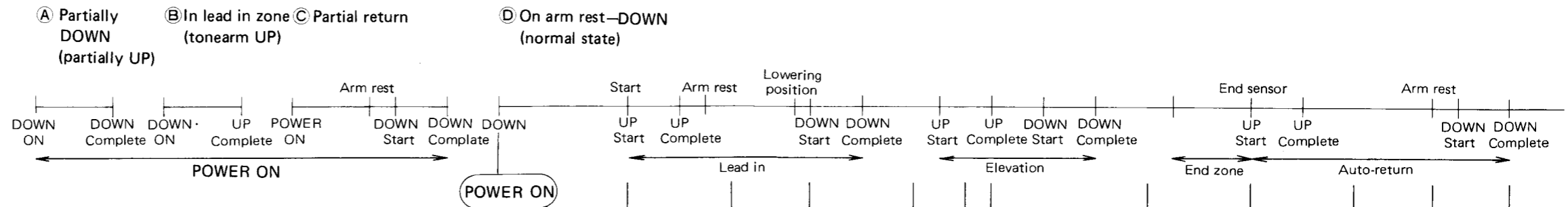

Actual mechanism operation

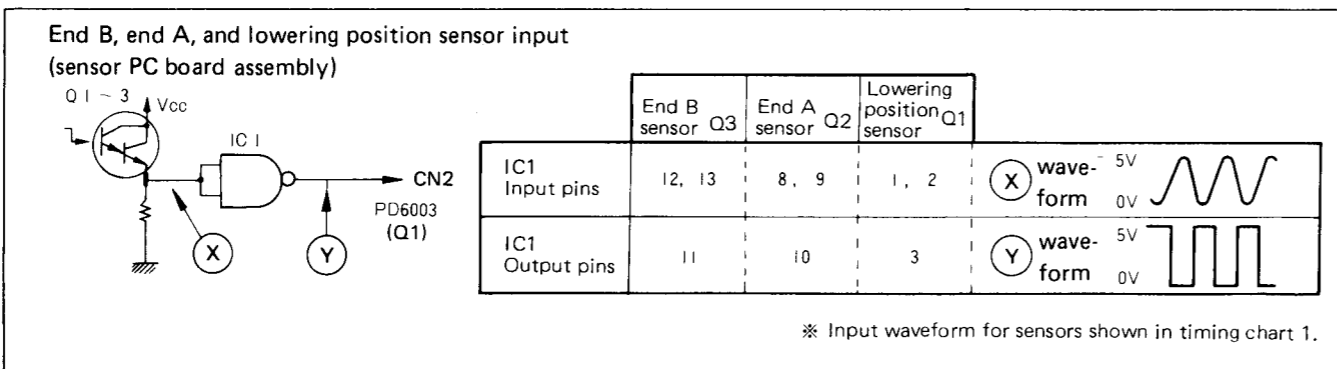
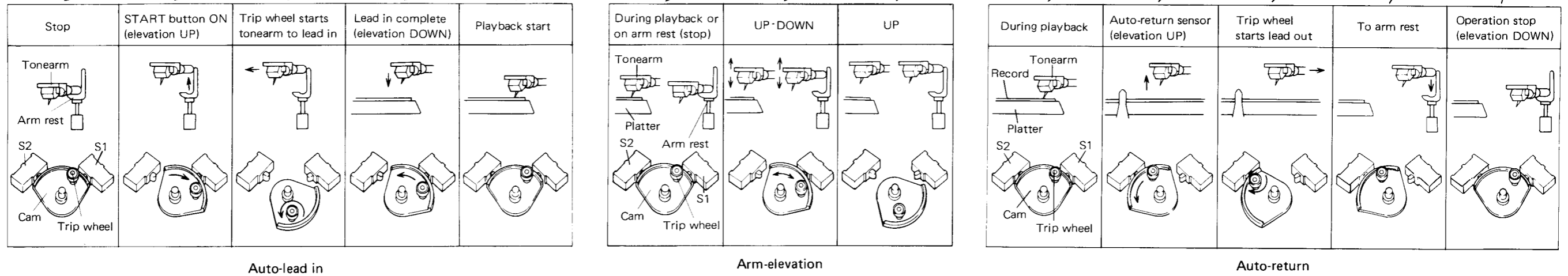

13. TROUBLESHOOTING

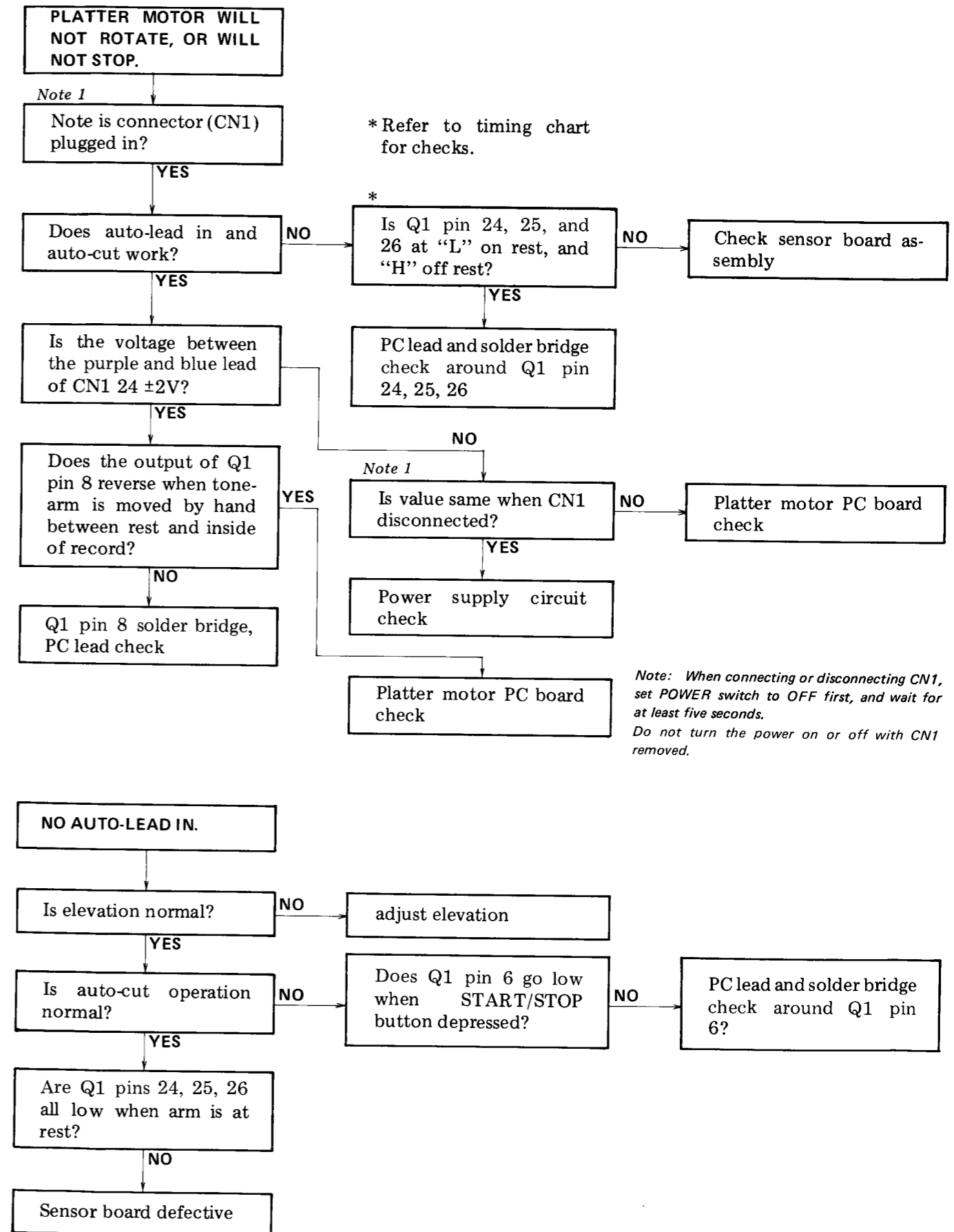
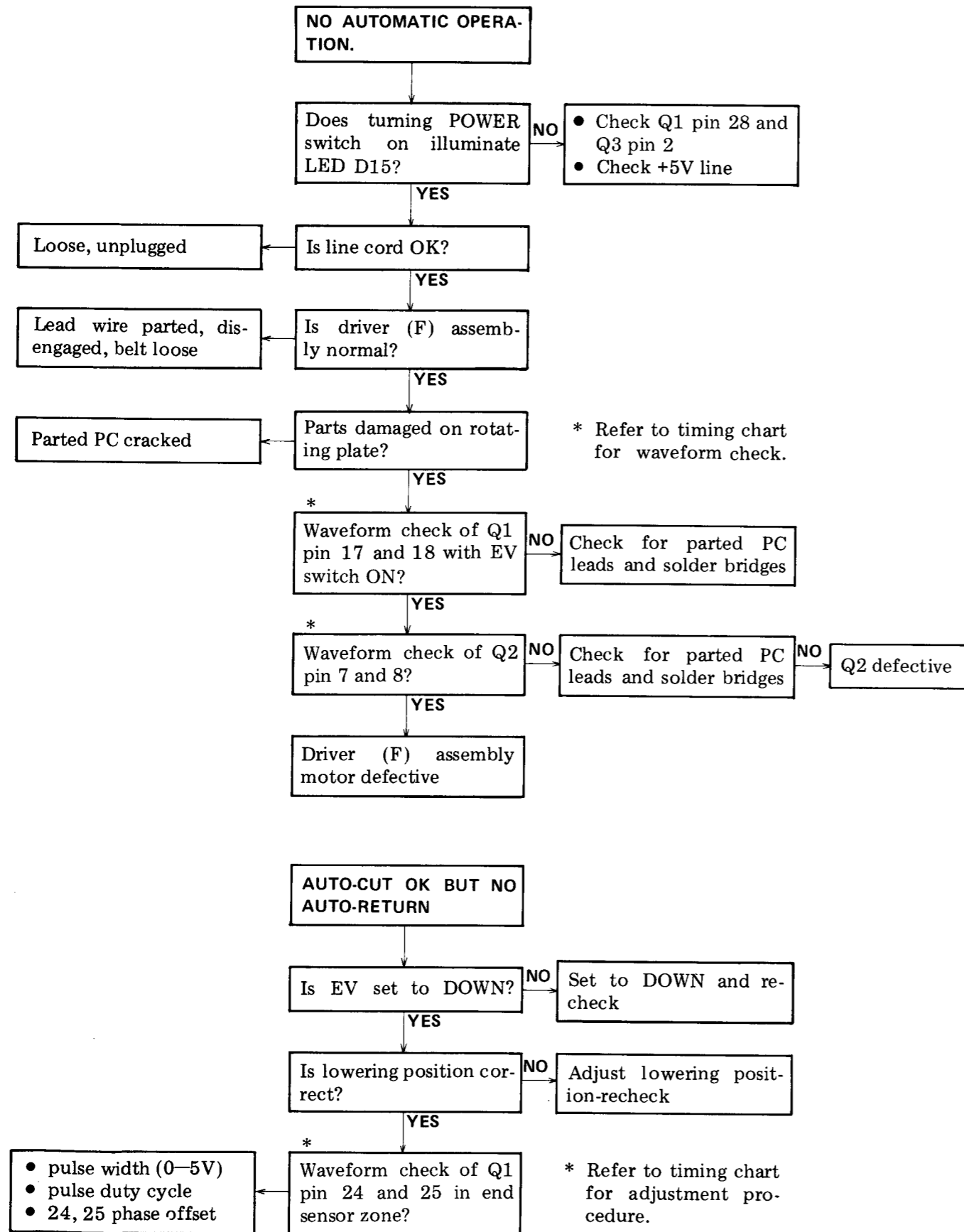

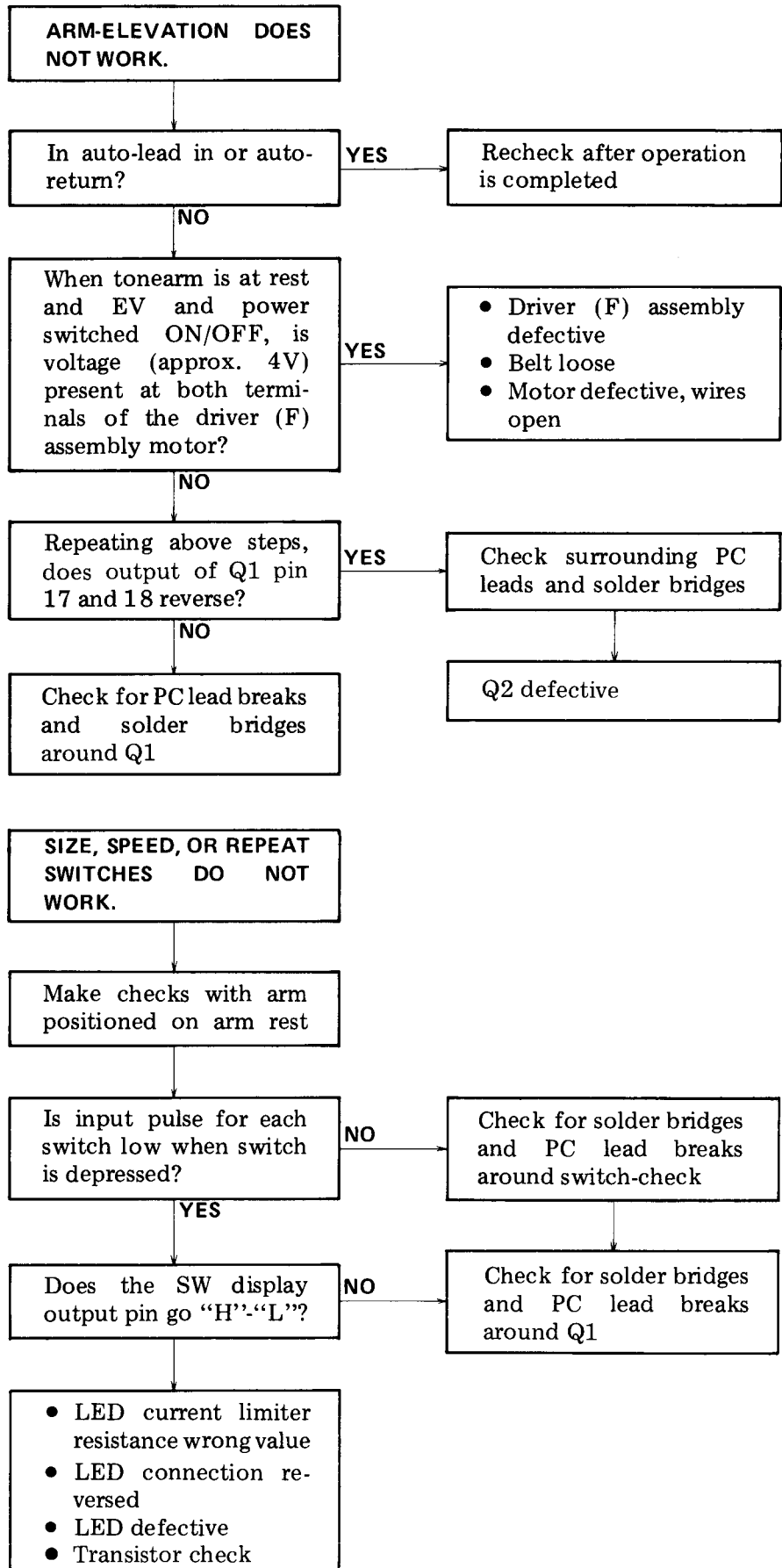

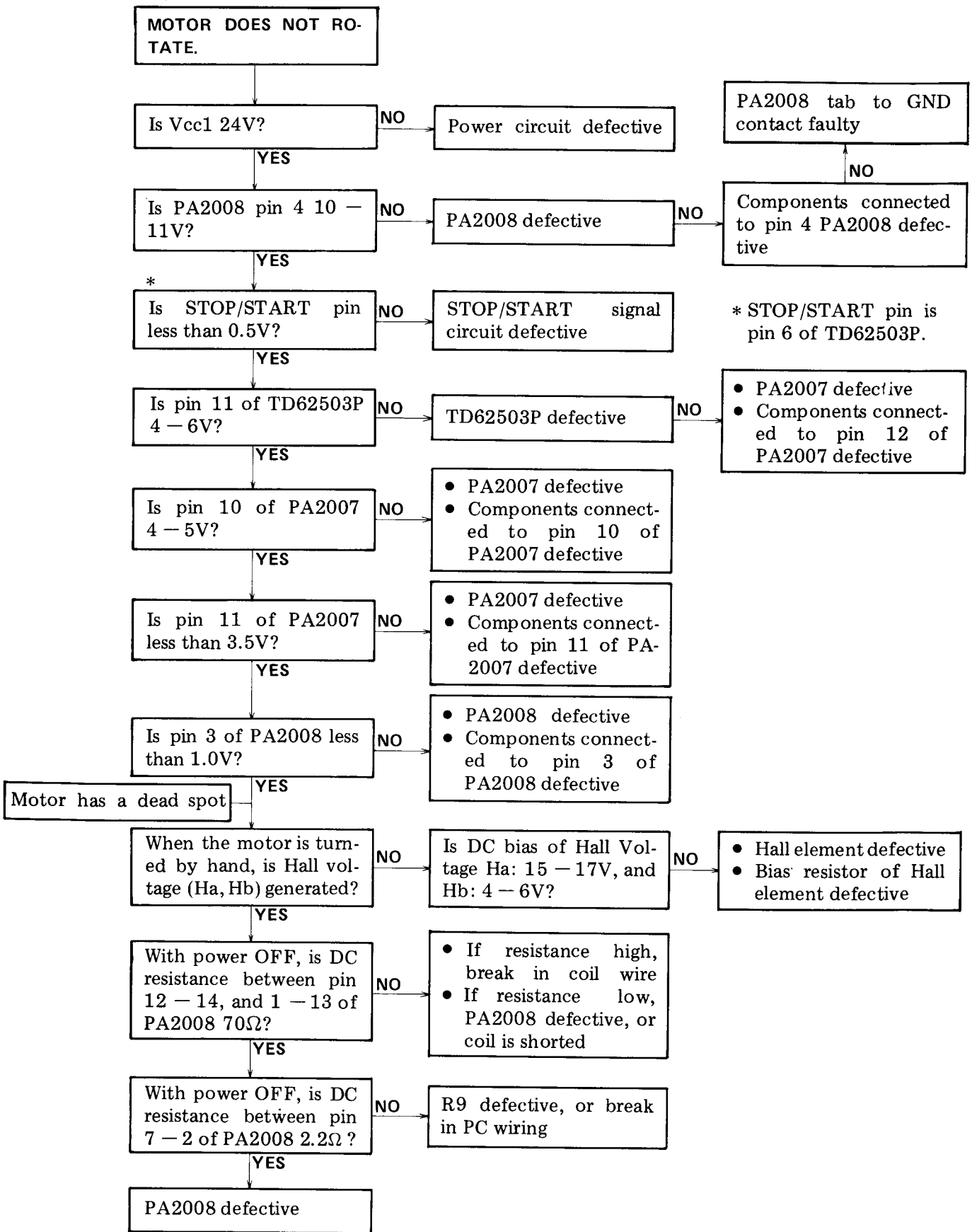

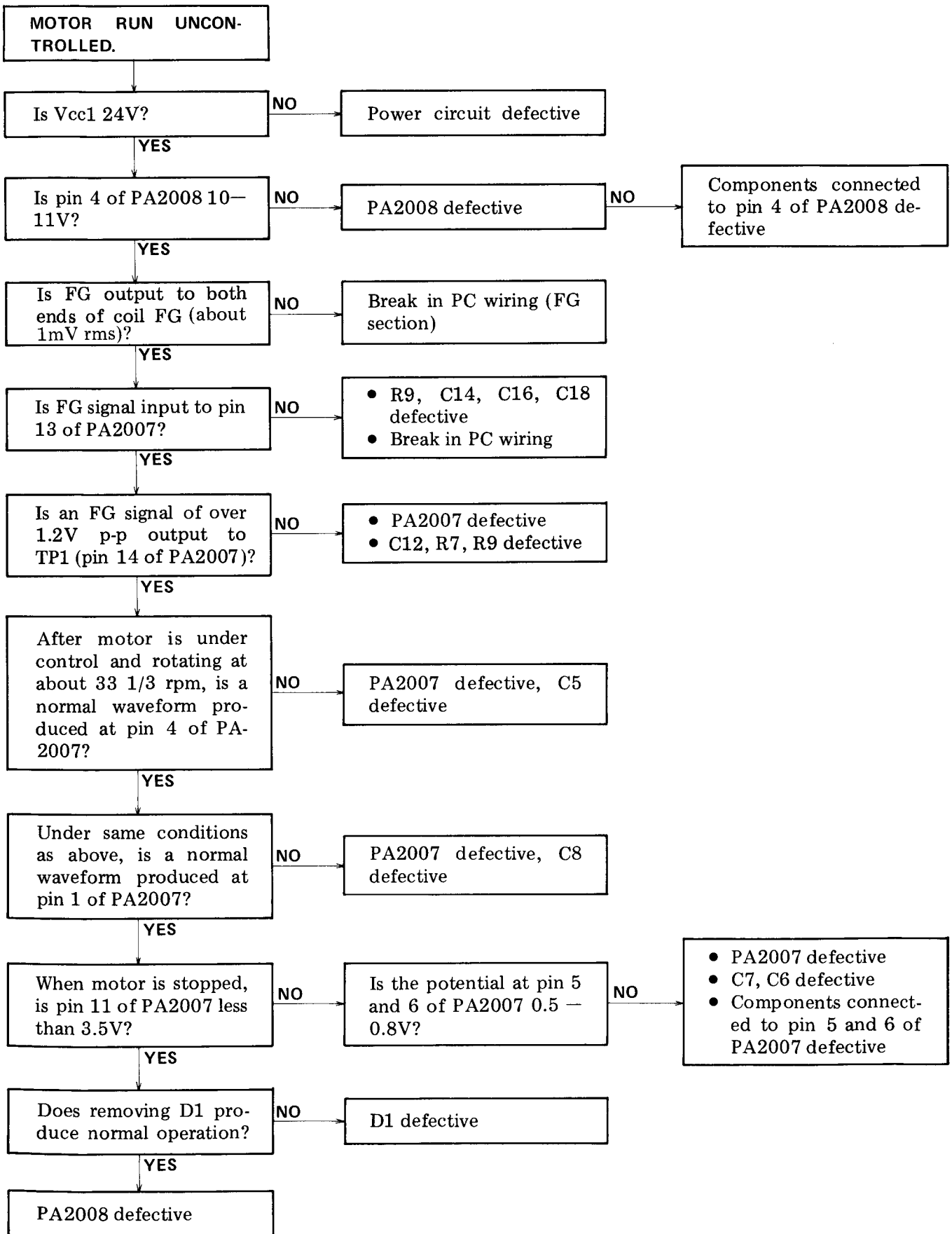

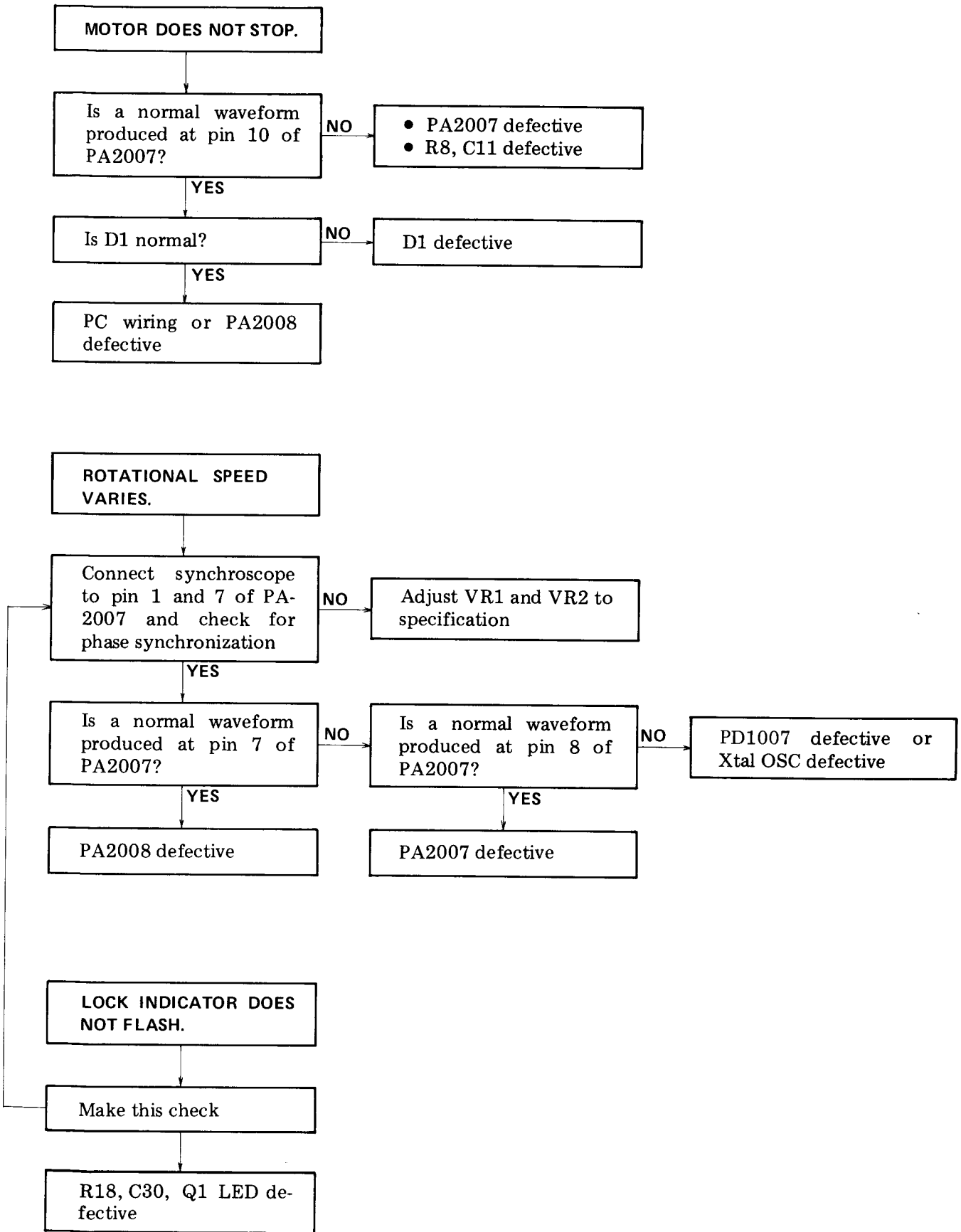

14. ADJUSTMENTS

14.1 STYLUS LOWERING POSITION

1. Remove the rubber plug (Fig. 14-1).
2. If the tonearm lowers too far to the outside of the record, turn the adjusting screw clockwise.
3. If the tonearm lowers too far to the inside of the record, turn the adjusting screw counter-clockwise.

Specifications for test record use.

30cm lowering position . . . adjust to lower between count 305 and 316.

17cm lowering position . . . adjust to lower between count 174 and 185.

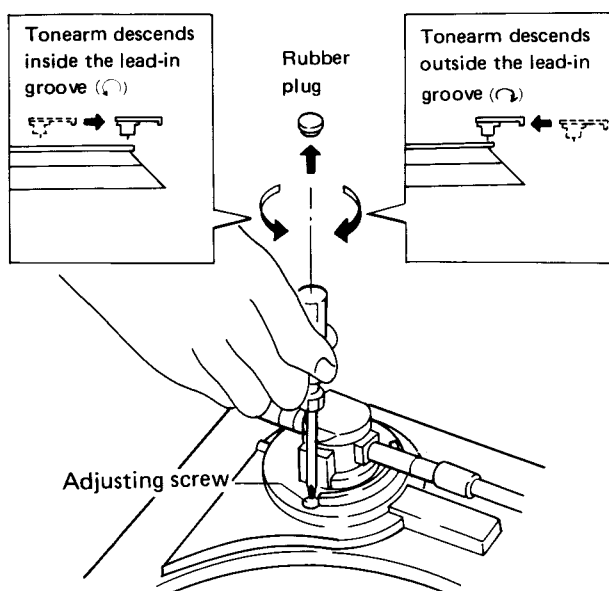

Fig. 14-1 Stylus lowering position

14.2 END SENSOR SENSITIVITY ADJUSTMENT

1. Remove the platter and top cover unit.
2. Make certain the shutter will pass between the sensor board assembly positioned slightly above center (Fig. 14-2).

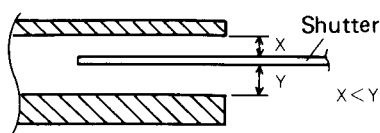
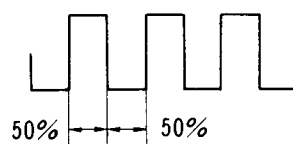

Fig. 14-2 Shutter position

3. Connect an oscilloscope to PD6003 pin 25 (end sensor A) (CN2 3 pin), and PD6003 pin 24 (end sensor B) (CN2 2 pin).
4. Turn the power ON and set the arm-elevation to UP.
Position the tonearm over the lead out groove zone of the record as if playback were in progress.

5. While making certain outside light is not directly striking the sensor section, adjust VR1 and VR2 so that the output waveform (pulse) for sensors A and B are both at approximately 50% duty cycle (Fig. 14-3, 14-5).



Adjust pulse width of end sensor A and B to 50% duty cycle.

Fig. 14-3 Output waveform 1

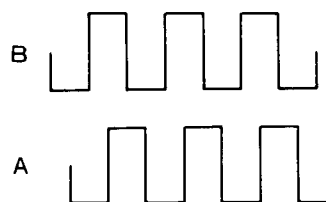

The phase of end sensor B leads end sensor A 90°.

Fig. 14-4 Output waveform 2

6. Next, move the tonearm toward the inside of the record at about the speed the tonearm would normally trace the lead out groove.
7. Make certain the phase of end sensor B is 90° advanced over end sensor A (Fig. 14-4).

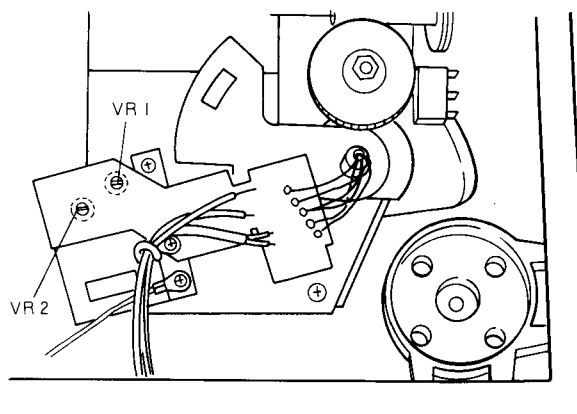

Fig. 14-5 VR1, VR2 position

14.3 MOTOR OPERATING POINT ADJUSTMENT

1. Set the speed to 33 1/3 rpm and depress the START/STOP button to put the unit into the operational mode.
2. Connect a buffer amp to pin 1 of IC PA2007, and connect the output to a oscilloscope (Fig. 14-6).
3. When a waveform like that shown in Fig. 14-7 is obtained, vary oscilloscope gain until a sawtooth wave with 5 div peak-to-peak is obtained. Then, referring to Fig. 14-7, adjust VR1 until a to b equals 2.8 to 2.2 (Make sure noise does not affect adjustment.)
4. When the 33 1/3 rpm adjustment is completed, adjust VR2 using the same procedure (item 2 and 3 above) for 45 rpm. Always adjust 33 1/3 first, and always adjust 33 1/3 if 45 rpm is to be adjusted even though it might be accurate.
5. Connect pin 7 of PA2007 to a oscilloscope and make certain the frequency for 33 1/3 rpm is 55.5Hz, and that for 45 rpm is 75Hz.

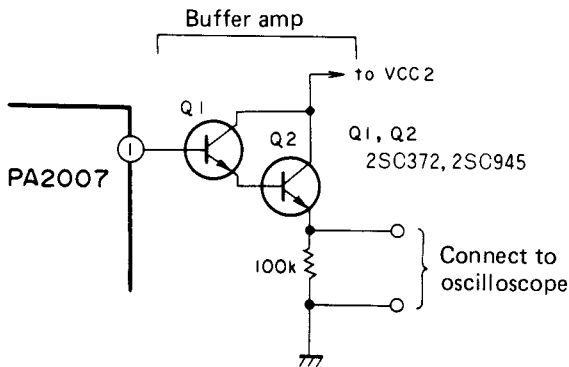

Fig. 14-6 Connect buffer amp

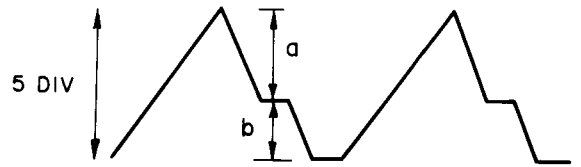

Fig. 14-7 Waveform

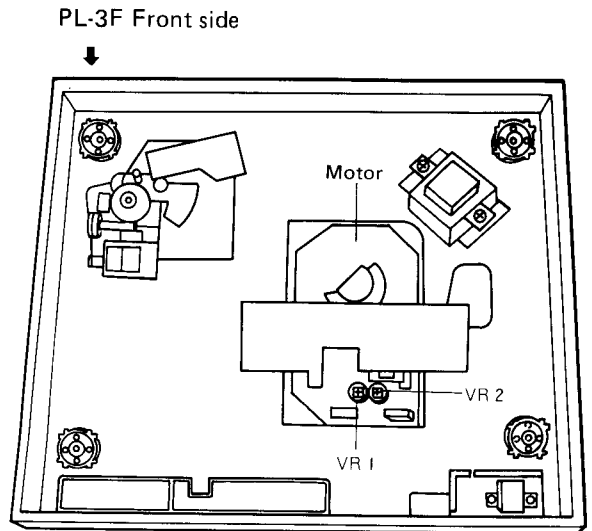

Fig. 14-8 VR1, VR2 position

14. RÉGLAGE

14.1 POSITION DE DESCENTE DE LA POINTE DE LECTURE

1. Retirer l'obturateur en caoutchouc (Fig. 14-1).
2. Si le bras acoustique descend trop loin à l'extérieur du disque, tourner la vis de réglage dans le sens des aiguilles d'une montre.
3. Si le bras acoustique descend trop loin sur le disque, tourner la vis de réglage dans le sens inverse des aiguilles d'une montre.

Caractéristiques de descente sur disque:

Position de descente sur disque 30 cm régler pour une descente entre 305 et 316.

Position de descente sur disque 17 cm régler pour une descente entre 174 et 185.

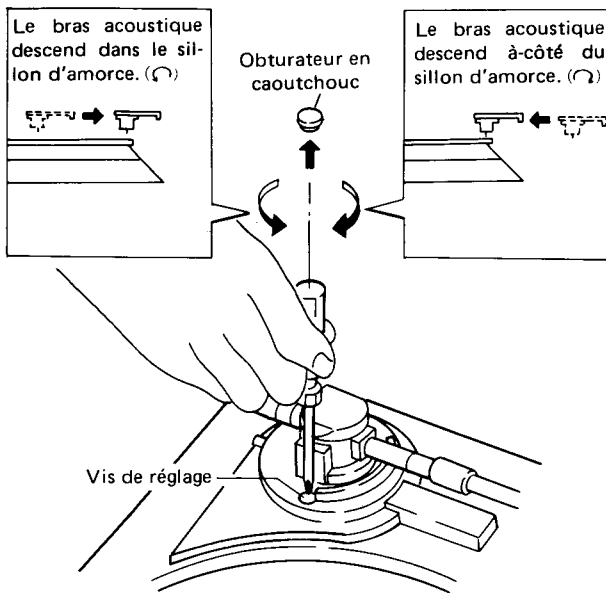

Fig. 14-1 Position de descente de la pointe de lecture

14.2 REGLAGE DE SENSIBILITE DE CAPTEUR DE FIN DE DISQUE

1. Déposer le plateau ainsi que le capot anti-poussière.
2. Veiller à ce que le volet passe entre l'ensemble de plateau de capteur positionné légèrement au-dessus du centre (Fig. 14-2).

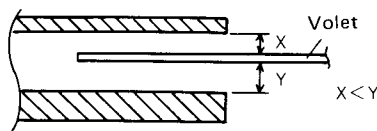

Fig. 12-2 Position du volet

3. Connecter un oscilloscope à la broche 25 de PD6003 (capteur A de fin de disque) (CN2 à 3 broches) et la broche 24 de PD6003 (capteur B de fin de disque) (CN2 à 2 broches).
4. Mettre sous tension et amener le lève-bras sur Up. Positionner le bras acoustique au-dessus du sillon de sortie du disque, comme à la fin de sa reproduction normale.
5. Tout en veillant à ce qu'aucune lumière extérieure n'atteigne le capteur, régler VR1 et VR2 de manière à ce que la forme d'onde de sortie (impulsion) pour les capteurs A et B soit d'environ 50 % du cycle efficace (Fig. 14-3, 14-5).

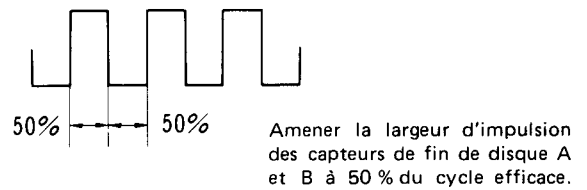

Fig. 14-3 Forme d'onde de sortie 1

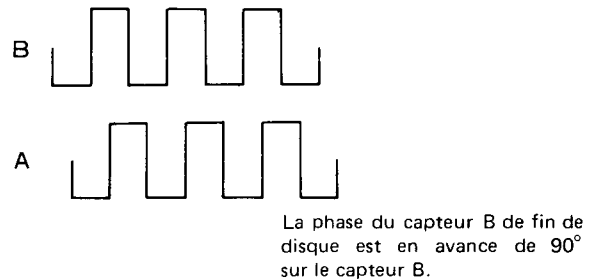

Fig. 14-4 Forme d'onde de sortie 2

6. Amener le bras acoustique vers l'intérieur du disque à environ la vitesse à laquelle il avancerait sur le sillon de sortie.
7. Veiller à ce que la phase du capteur B de fin de disque soit en avance de 90° sur celle du capteur A (Fig. 14-4).

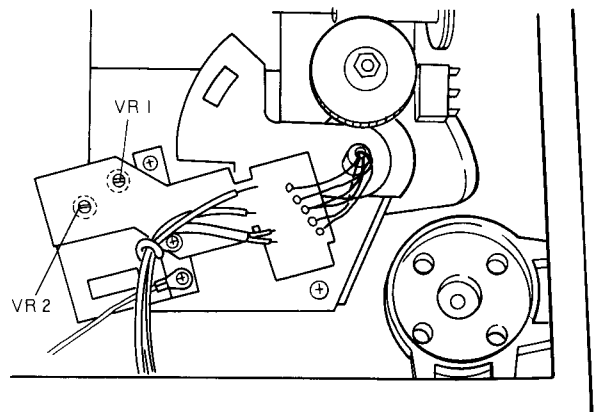

Fig. 14-5 Position de VR1 et VR2

14.3 REGLAGE DE POINT D'ACTIONNEMENT DU MOTEUR

1. Passer sur 33 1/3 tr/mn et appuyer sur la touche START/STOP afin de mettre la table de lecture en marche.
2. Brancher un amplificateur intermédiaire sur la broche 1 du CI PA2007 et connecter la sortie à un oscilloscope (Fig. 14-6).
3. Si la forme d'onde est semblable à celle de la Fig. 14-7, faire varier le gain de l'oscilloscope jusqu'à ce qu'elle soit en dents de scie avec 5 divisions crête à crête puis, en se reportant à la Fig. 14-7, régler VR1 jusqu'à ce que a à b soit égal à 2.8 à 2.2 (veiller à ce qu'aucun bruit ne gêne le réglage).
4. Lorsque le réglage de 33-1/3 tr/mn est terminé, régler VR2 de la même manière (alinéas 2 et 3 ci-dessus) pour 45 tr/mn. Toujours commencer par régler 33-1/3. Si 45 tr/mn doit être réglée, il convient de commencer par régler 33-1/3 tr/mn, même si cette dernière vitesse est bonne.
5. Connecter la broche 7 de PA2007 à un oscilloscope et vérifier si la fréquence est bien de 55.5Hz pour 33-1/3 tr/mn et de 75Hz pour 45 tr/mn.

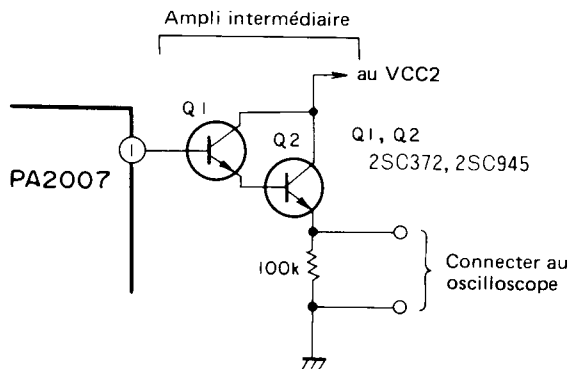

Fig. 14-6 Connexion de l'amplificateur intermédiaire

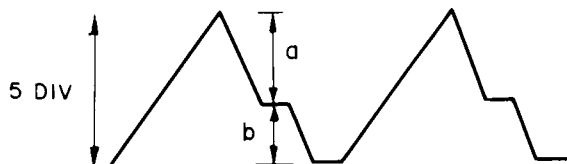

Fig. 14-7 Forme d'onde

Avant de la PL-3F

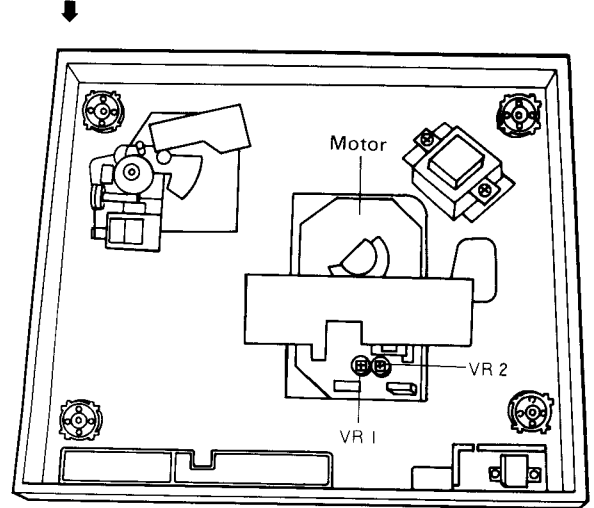

Fig. 14-8 Position de VR1 et VR2

14. AJUSTE

14.1 POSICIÓN DE DESCENSO DE LA AGUJA

1. Sacar el enchufe de goma (Fig. 14-1).
2. Si el brazo fonocaptor desciende muy lejos del tocadiscos, girar el tornillo ajustador hacia la derecha.
3. Si el brazo fonocaptor desciende muy lejos dentro del tocadiscos, girar el tornillo ajustador hacia la izquierda.

Especificaciones para el uso del tocadiscos de prueba:

Posición de descenso de 30 cm Ajustar para descender entre el valor 305 y 316.

Posición de descenso de 17 cm Ajustar para descender el valor 174 y 185.

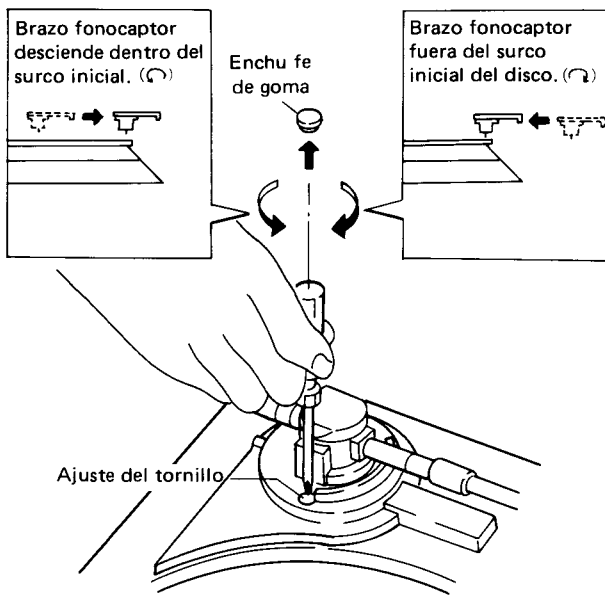

Fig. 14-1 Posición de descenso de la aguja

14.2 AJUSTE DE LA SENSIBILIDAD DEL SENSOR

1. Sacar el plato y la cubierta de la parte superior.
2. Estar seguros que el obturador pasa entre el conjunto de placa del sensor colocada ligeramente encima del centro (Fig. 14-2).

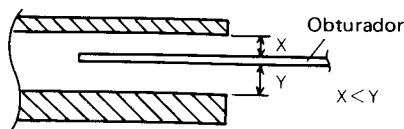
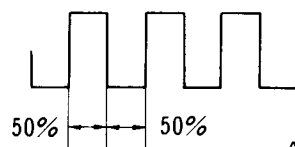

Fig. 14-2 Posición del obturador

3. Conectar un osciloscopio a la pastilla 25 del PD6003 (sensor A) (pastilla 3 CN2) y la pastilla 24 del PD6003 (sensor B) (pastilla 2 CN2).
4. Conectar la alimentación y ajustar la elevación del brazo a UP. Poner el brazo fonocaptor en la parte del surco de la salida del disco como si la reproducción estuviera realizándose.
5. Mientras se está seguro que las luces externas no están dando directamente a la sección del sensor, ajustar VR1 y VR2 de forma que que la forma de ondas de salida para los sensores A y B sean ambas aproximadamente del ciclo de rendimiento del 50 % (Fig. 14-3, 14-5).



Ajustar la anchura del pulso del sensores A y B a un ciclo de rendimiento del 50 %.

Fig. 14-3 Forma de ondas de salida 1

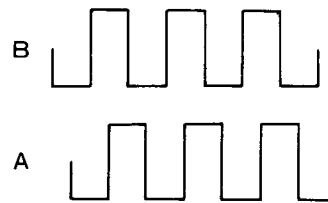

La fase del sensor B está delante 90° del sensor A.

Fig. 14-4 Forma de onda de salida

6. Luego mover el brazo fonocaptor hacia el interior del disco y la velocidad el brazo fonocaptor trazará normalmente el surco de salida.
7. Estar seguros que la fase del sensor B está 90° adelantada sobre el sensor A. (Fig. 14-4)

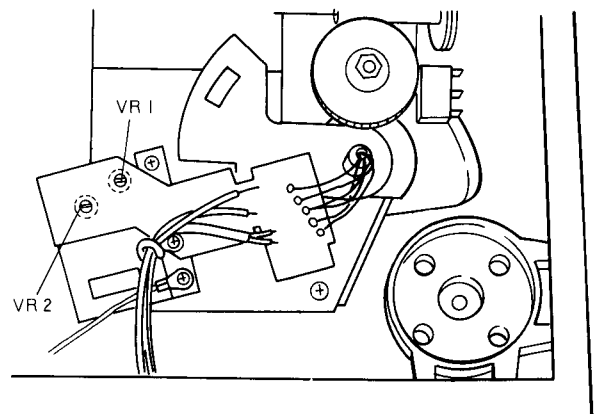

Fig. 14-5 Posiciones de VR1, VR2

14.3 AJUSTAR DEL PUNTO DE FUNCIONAMIENTO DEL MOTOR

1. Ajustar la velocidad a 33-1/3 rpm y presionar el botón START/STOP para poner el aparato en el modo de funcionamiento.
2. Conectar un amplificador intermedio a la pastilla 1 del IG PA2007 y conectar la salida a un osciloscopio (Fig. 14-6).
3. Cuando una forma de onda como la mostrada en la figura 14-7 es obtenida, variar la ganancia del osciloscopio hasta que la onda de dientes de sierra se obtenga 5 divisiones de pico a pico. Luego refiriéndose a la figura 14-7 ajustar VR-1 hasta que a-b iguale 2.8 a 2.2 (estar seguros que el ruido no afecta el ajuste).
4. Cuando el ajuste a 33-1/3 rpm es completo, ajustar VR2 utilizando el mismo procedimiento (puntos 2 y 3 de arriba) para 45 rpm. Siempre ajustar a 33-1/3 primero, y siempre ajustar 33-1/3 si tiene que ajustar 45 rpm. con precisión.
5. Conectar la pastilla 7 del PA2007 al osciloscopio y estar seguro que la frecuencia de 33-1/3 rpm es de 55.5Hz y que para 45 rpm es de 75Hz.

Lado frontal de PL-3F

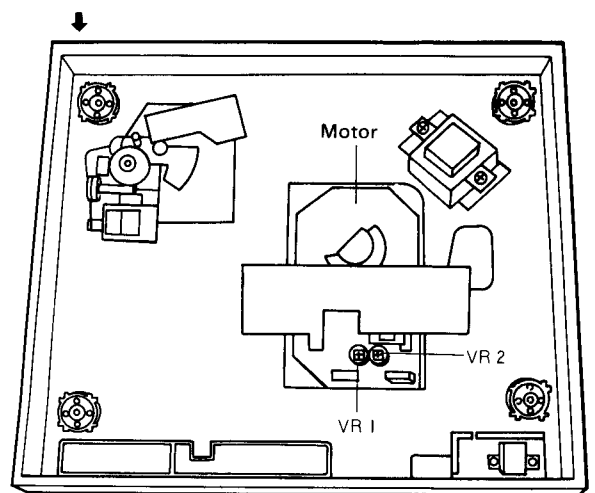

Fig. 14-8 Posiciones de VR1 y VR2

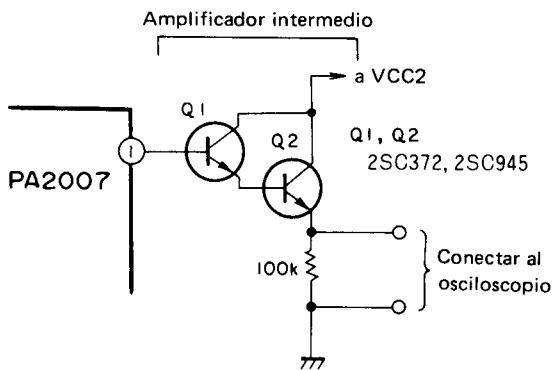

Fig. 14-6 Conectar al amplificador intermedio

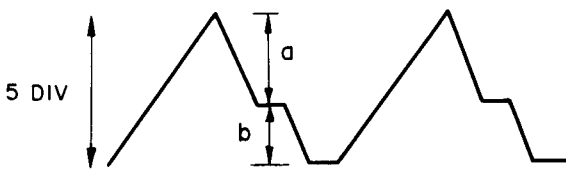

Fig. 14-7 Forma de onda

15. SAFETY INFORMATION

1. SAFETY PRECAUTIONS

The following check should be performed for the continued protection of the customer and service technician.

LEAKAGE CURRENT CHECK

Measure leakage current to a known earth ground (water pipe, conduit, etc.) by connecting a leakage current tester such as Simpson Model 229-2 or equivalent between the earth ground and all exposed metal parts of the appliance (input/output terminals, screwheads, metal overlays, control shaft, etc.). Plug the AC line cord of the appliance directly into a 120V AC 60Hz outlet and turn the AC power switch on. Any current measured must not exceed 0.5mA.

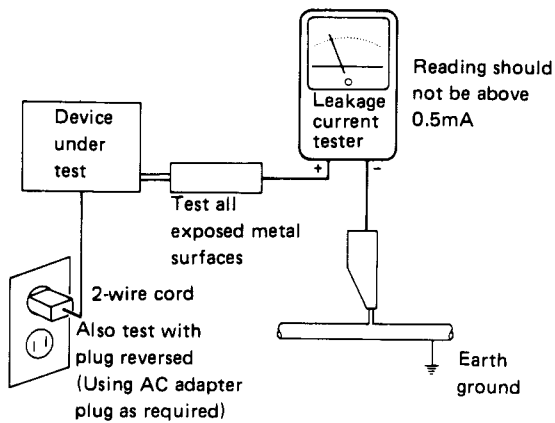

AC Leakage Test

ANY MEASUREMENTS NOT WITHIN THE LIMITS OUTLINED ABOVE ARE INDICATIVE OF A POTENTIAL SHOCK HAZARD AND MUST BE CORRECTED BEFORE RETURNING THE APPLIANCE TO THE CUSTOMER.

2. PRODUCT SAFETY NOTICE

Many electrical and mechanical parts in the appliance have special safety related characteristics. These are often not evident from visual inspection nor the protection afforded by them necessarily can be obtained by using replacement components rated for voltage, wattage, etc. Replacement parts which have these special safety characteristics are identified in this Service Manual.

Electrical components having such features are identified by marking with a ⚠ on the schematics and on the parts list in this Service Manual.

The use of a substitute replacement component which does not have the same safety characteristics as the PIONEER recommended replacement one, shown in the parts list in this Service Manual, may create shock, fire, or other hazards.

Product Safety is continuously under review and new instructions are issued from time to time. For the latest information, always consult the current PIONEER Service Manual. A subscription to, or additional copies of, PIONEER Service Manual may be obtained at a nominal charge from PIONEER.

16. FOR HEMT, HBT, S AND S/G TYPES

PL-3F/HEMT, HBT, S and S/G types are the same as PL-3F/KUT type with the exception of the following sections.

16.1 CONTRAST OF MISCELLANEOUS PARTS

Mark	Symbol & Description	Part No.				
		KUT type	HEMT type	HBT type	S type	S/G type
⚠	Panel	PNY-285	PNY-306	PNY-306	PNY-306	PNY-306
	Head shell assembly	PXB-592	PXB-592	PXB-592	PXB-564	PXB-564
	Cartridge	PXV-933	PXV-933
	AC power cord assembly	PDF-204	PDF-202	PDF-203	PDF-196	PDF-196
	Control unit	XWM-190	XWM-192	XWM-192	XWM-190	XWM-190
⚠	Insulator damper	PEB-306	PEB-281	PEB-281	PEB-281	PEB-281
	Insulator spring	PBH-427	PBH-412	PBH-412	PBH-412	PBH-412
	Insulator cap	PNY-449	PNY-284	PNY-284	PNY-284	PNY-284
	Cartridge mounting screw	PBA-911	PBA-911
	Power transformer (120V)	PTT-218
⚠ ★	Power transformer (220V, 240V)	...	PTT-219	PTT-219
⚠ ★	Power transformer (110V, 120V, 220V, 240V)	PTT-220	PTT-220
⚠ ★★	PU cord	PDE-197	PDE-142	PDE-142	PDE-142	PDE-142
	Line voltage selector	...	PSB-002	PSB-002	PSB-007	PSB-007
⚠ ★★	Screw 3 x 8 (For line voltage selector)	...	PPZ30P100FMC	PPZ30P100FMC	PPZ30P100FMC	PPZ30P100FMC
	Fuse (T800mA)	...	REK-099	REK-099
	Accessory Parts					
	Operating instructions (English)	PRB-296	...	PRB-273	PRB-273	PRB-273
	Operating instructions (English/German/Italian/French)	...	PRE-032
	Head shell assembly	PXB-564	PXB-564	PXB-564
	Accessory screw assembly	PXB-125	PXB-125	PXB-125
	Cartridge mounting screw	PBA-530	PBA-530	PBA-530
	Cartridge mounting screw	PBA-531	PBA-531	PBA-531
	Cartridge mounting screw	PBA-532	PBA-532	PBA-532
	Cartridge mounting nut	PBN-902	PBN-902	PBN-902
	Cartridge washer	B23-642	B23-642	B23-642
	Packing case	PHH-195	PHH-196	PHH-196	PHH-197	PHH-198
	Top pad	PHC-049

16.2 SCHEMATIC DIAGRAM

● For HEMT, HBT Types

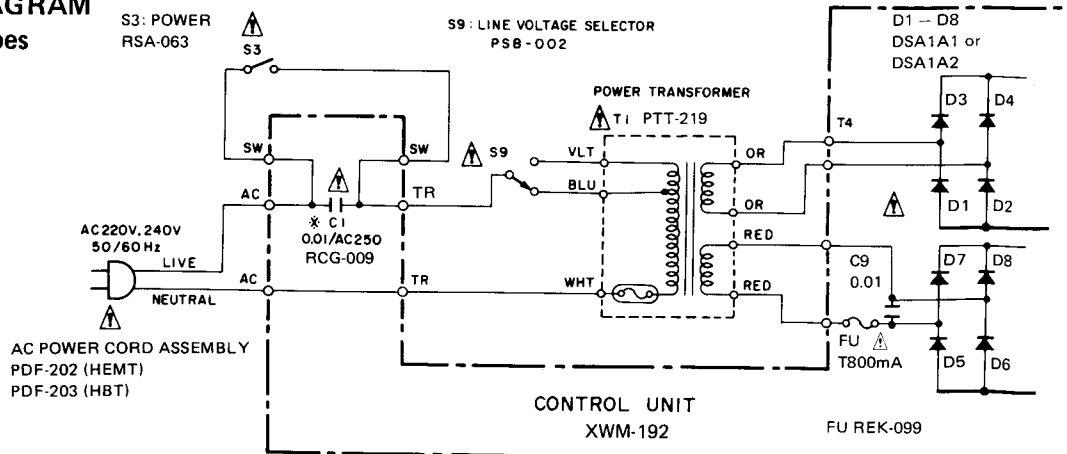

● For S, S/G Types

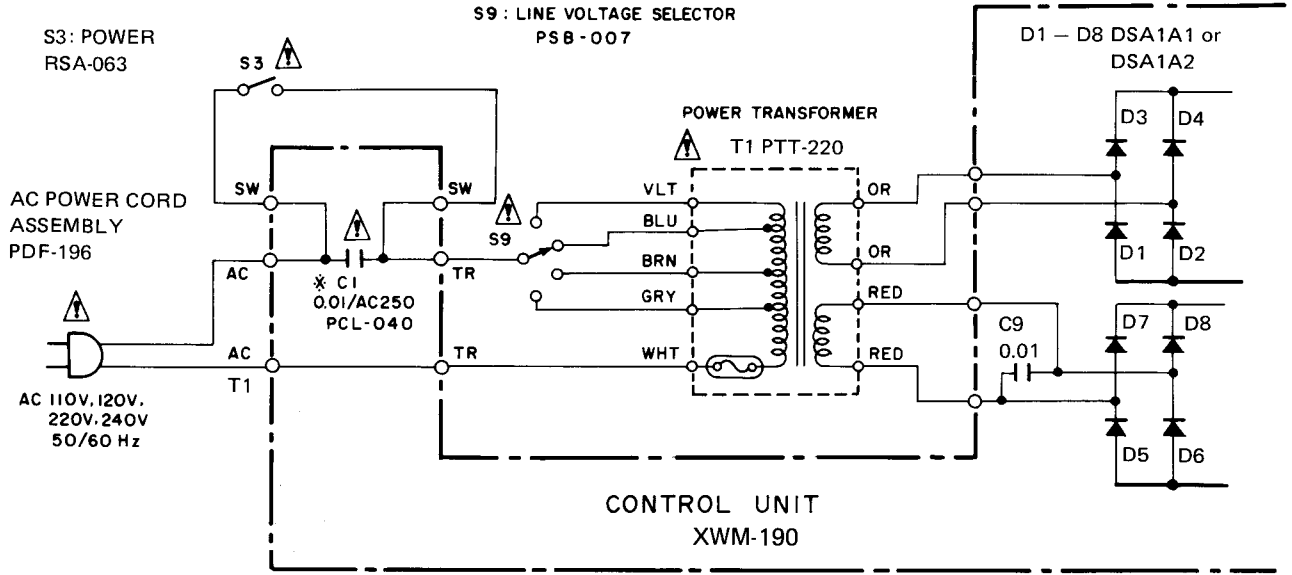

16.3 P.C. BOARD (CONTROL UNIT · XWM-192) AND PARTS LIST

● For HEMT, HBT Types

Control unit · XWM-192 (for HEMT and HBT types) is the same as the control unit · XWM-190 (for S and S/G types) with the exception of the following sections.

Mark	Symbol & Description	Part No.		Remarks
		XWM-190	XWM-192	
⚠	C1 Ceramic capacitor (0.01/AC250V) Fuse holder	PCL-040	RCG-009	
		...	Non supply	

Q3

Q4

Q5 Q2

