

ADDITIONAL

 PIONEER®

Service Manual

- This service manual describes the mechanical operations and adjustments, and the D.D. motor employed in the following models.

STEREO TURNTABLE

PL-200

PL-200X

PL-255

PL-300

PL-300X

PL-400

PL-400X

CONTENTS

1.	PL-200 PANEL FACILITIES	3	7.4	Operation of the PA2004 IC (comparator control)	16
2.	PL-255 PANEL FACILITIES	4	7.5	Operation of the PA2005 IC (drive control)	17
3.	PL-400 PANEL FACILITIES	6	7.6	Block diagram (PL-200, PL-255)	21
4.	PL-300 PANEL FACILITIES	8	8.	MECHANISM DESCRIPTIONS	
5.	DISASSEMBLY		8.1	PL-200 mechanism operating	22
5.1	Panel and base plate	9	8.2	PL-400 mechanical operation	24
5.2	D.D. motor and tonearm	10	9.	ADJUSTMENT	
6.	PANEL AND BASE PLATE ASSEMBLY		9.1	Stylus descent position	28
6.1	PL-200, PL-300	11	9.2	Auto return adjustment	28
6.2	PL-255, PL-400	12	9.3	D.D. motor adjustment (PL-300 and PL-400)	29
7.	CIRCUIT DESCRIPTIONS		9.4	D.D. motor adjustment (PL-200 and PL-255)	29
7.1	Block diagram (PL-300, PL-400)	13			
7.2	Motor operation	14			
7.3	Operation of the PD1003 IC (oscillator stage)	16			

1. PL-200 PANEL FACILITIES

BEFORE CONNECTING, CHECK THE FOLLOWING:

- Switch the power to the amplifier off to prevent damage to the speaker system.
- The cartridge furnished with your turntable is an MM type. Be sure to use a stereo amplifier which has PHONO input jacks for this type of cartridge.

NOTE:

If you are using a low-output moving coil (MC) cartridge, you will need a special MC transformer or a head amplifier, or a stereo amplifier with a built-in MC amplifier.

CONNECTION PROCEDURE

1. Insert the phono cables (white and red) into the PHONO input jacks of the stereo amplifier (white for left channel into L jack, and red for right channel into R jack).

2. Connect the ground lead with the Y-shaped connector at the end to the ground terminal.
3. Insert the power plug into the convenience AC outlet of the amplifier or a wall outlet.

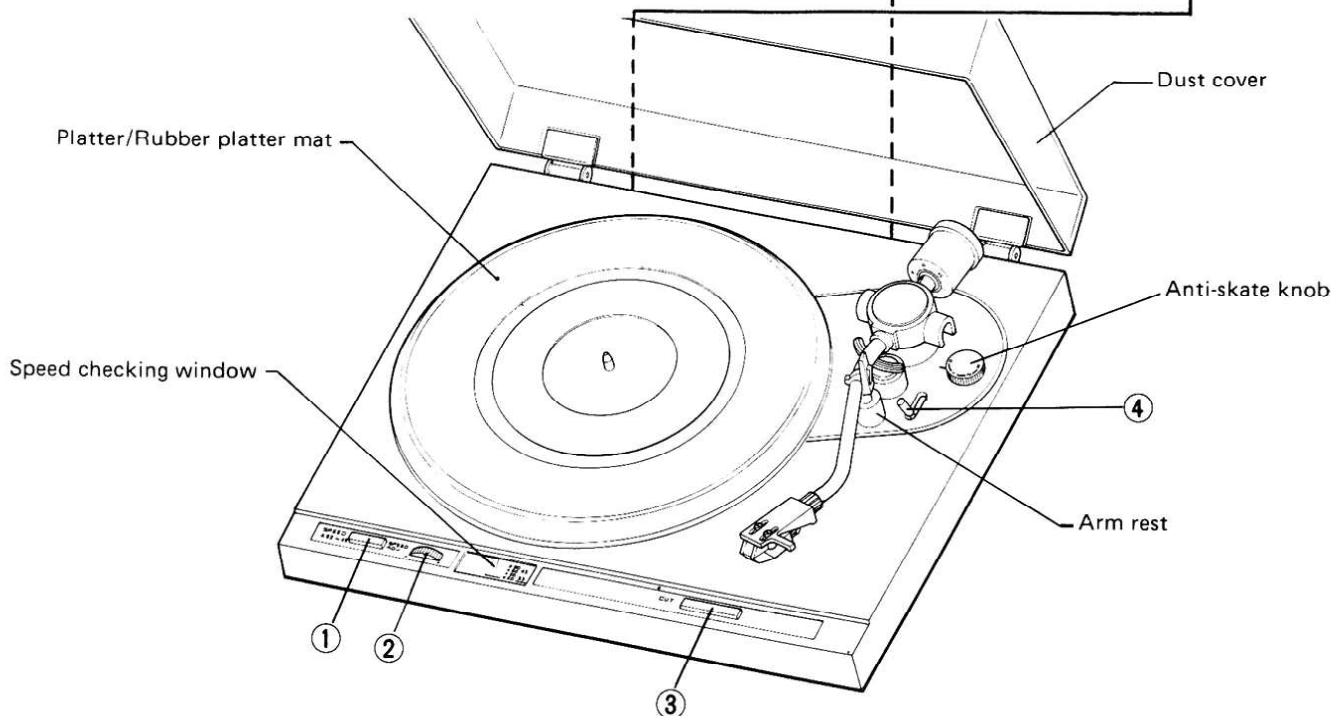
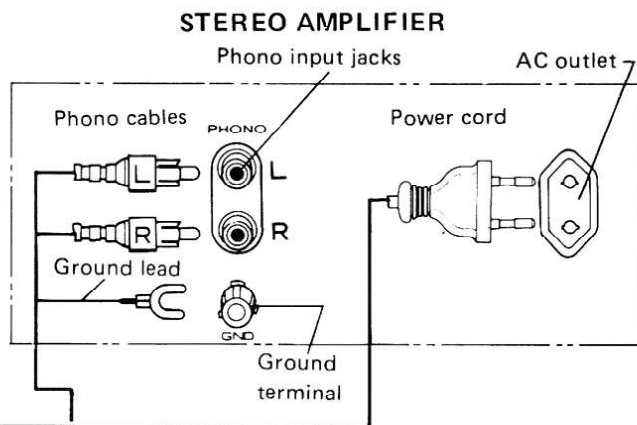

① SPEED SELECTOR BUTTON

45 When this button is depressed, the platter will rotate at 45rpm. Depress for playing 45 rpm records, singles or EP's.

33 When this button is set to the released position, the platter will rotate at 33-1/3rpm. Release for playing 33-1/3rpm records like LP's.

② SPEED ADJUSTMENT KNOB

Turn this knob when finely adjusting the speed of the platter. The speed of platter will increase when the knob is turned clockwise in the direction of "+"; it will decrease when turned counterclockwise in the direction of "-".

③ CUT BUTTON

If this button is depressed while the record is playing, the tonearm automatically returns to the arm rest, and the power to the turntable is cut off.

④ ARM-ELEVATION LEVER

UP (▾): When this lever is set to this position, the tonearm will rise. Set it to UP before record play and when you want to stop record play while a track is being played or when you want to change over to a different track.

DOWN (▴): When the lever is set to this position, the tonearm will be lowered. If it is set to DOWN for record play, the tonearm will be lowered onto the surface of the record, and play will begin.

2. PL-255 PANEL FACILITIES

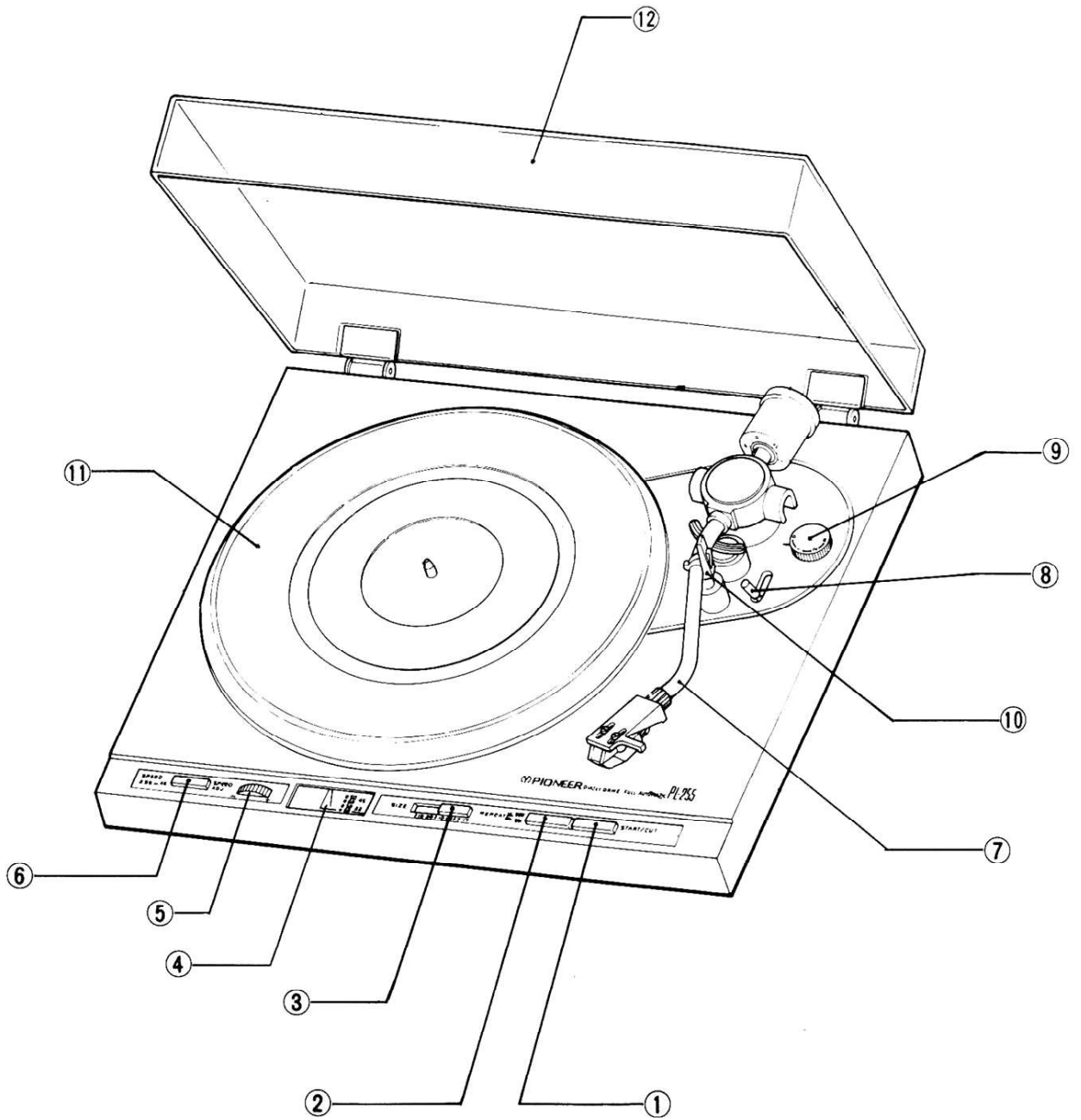

① START/CUT BUTTON

When this button is depressed, the power is turned on to the turntable, the strobe light comes on and the platter starts to rotate. With the RECORD SIZE SELECTOR set at one of the positions – 30, 25, or 17 – the tonearm moves automatically to the record disc as the platter starts rotating, thus starting record play.

If this button is depressed while the record is playing, the tonearm automatically returns to the arm rest, and the power to the turntable is cut off.

② REPEAT BUTTON

Push this button when you want to listen to the same record again. Press the button once more to release.

NOTE:

All you have to do for repeat play is to press the REPEAT button. There is no need to push the START/CUT button again.

③ RECORD SIZE SELECTOR

This selector selects the size of the record for automatic play.

7"17 For the automatic play of 17cm (7-inch) LP and EP records.

10"25 For the automatic play of 25cm (10-inch) LP records.

12"30 For the automatic play of 30cm (12-inch) LP records.

④ STROBE LIGHT/SPEED CHECKING WINDOW

This light comes on when the tonearm moves away from the arm rest toward the platter. It irradiates the stroboscope around the outside of the platter.

⑤ SPEED ADJUSTMENT KNOB

Turn this knob when delicately adjusting the speed of the platter. The speed of platter will increase when the knob is turned clockwise, in the direction of "+"; it will decrease when turned counterclockwise, in the direction of "-".

⑥ SPEED SELECTOR BUTTON

45 When this button is depressed, the platter will rotate at 45rpm. Depress for playing 45rpm records, singles or EP's.

33 When this button is set to the release position, the platter will rotate at 33-1/3rpm. Release for playing 33-1/3rpm records like LP's.

⑦ TONEARM

This tonearm is designed to apply the correct tracking force to the cartridge and to keep this force at the precise level for faithful tracking of the record grooves. It also has the job of switching the power on to the turntable.

- When the tonearm is moved from the arm rest to the platter, the power comes on, the strobe lamp lights up, and the platter rotates.
- When the tonearm is returned to the arm rest, the power to the turntable is cut off, the strobe light goes off, and the platter stops rotating.

⑧ ARM-ELEVATION LEVER

UP (): When this lever is set to this position, the tonearm will rise. Set it to UP before record play and when you want to stop record play while a track is being played or when you want to change over to a different track.

DOWN (): When the lever is set to this position, the tonearm will be lowered. If it is set to DOWN for record play, the tonearm will be lowered onto the surface of the record, and play will begin.

⑨ ANTI-SKATE KNOB

This knob is used to cancel out the harmful skating force which is generated during record play.

⑩ ARM REST/CLAMPER

The arm rest supports the tonearm when it is not being used. Set the tonearm on its rest when it is not playing records. Clamp it into position if you don't have any immediate plans to play records.

⑪ PLATTER/RUBBER PLATTER MAT

When the tonearm is moved and power is supplied to the turntable, the platter will start rotating at the set rotation speed. The rubber platter mat stabilizes the records and also absorbs external vibration.

⑫ DUST COVER

Keep this closed unless operating the controls or tonearm, or changing over records. This serves to keep dust from adhering to the records during record play. When fully opened and pulled straight up, this dust cover can be removed from the cabinet.

3. PL-400 PANEL FACILITIES

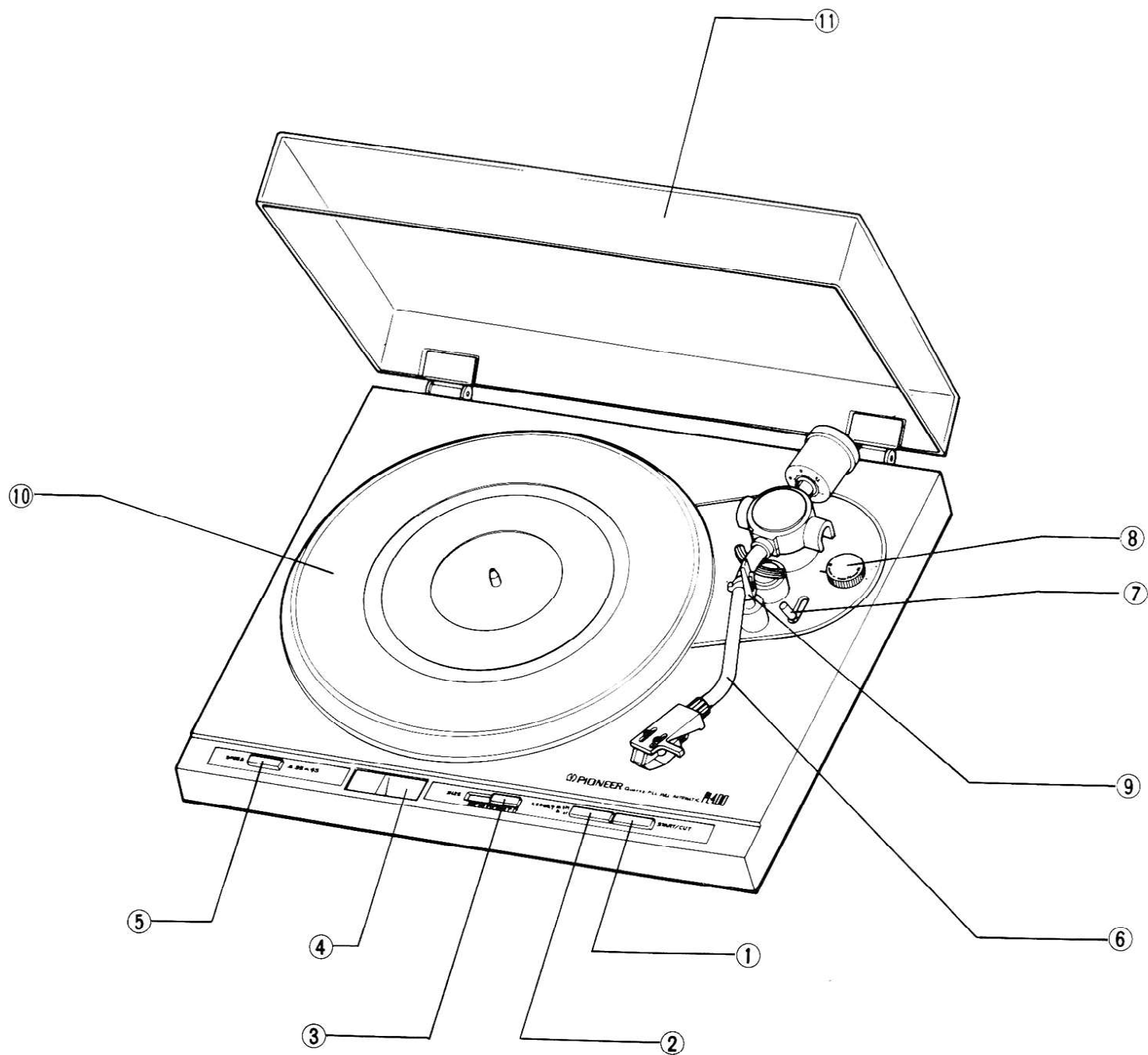

① START/CUT BUTTON

When this button is depressed, the power is turned on to the turntable, the strobe light comes on and the platter starts to rotate. With the RECORD SIZE SELECTOR set at one of the positions – 30, 25, or 17 – the tonearm moves automatically to the record disc as the platter starts rotating, thus starting record play.

If this button is depressed while the record is playing, the tonearm automatically returns to the arm rest, and the power to the turntable is cut off.

② REPEAT BUTTON

Push this button when you want to listen to the same record again. Press the button once more to release.

NOTE:

All you have to do for repeat play is to press the REPEAT button. There is no need to push the START/CUT button again.

③ RECORD SIZE SELECTOR

This selector selects the size of the record for automatic play.

7"17. . . . For the automatic play of 17cm (7-inch) LP and EP records.

10"25. . . . For the automatic play of 25cm (10-inch) LP records.

12"30. . . . For the automatic play of 30cm (12-inch) LP records.

④ STROBE LIGHT

This light comes on when the tonearm moves away from the arm rest toward the platter. It irradiates the stroboscope around the outside of the platter.

⑤ SPEED SELECTOR BUTTON

45 When this button is depressed, the platter will rotate at 45rpm. Depress for playing 45rpm records, singles or EP's.

33 When this button is set to the release position, the platter will rotate at 33-1/3rpm. Release for playing 33-1/3rpm records like LP's.

⑥ TONEARM

This tonearm is designed to apply the correct tracking force to the cartridge and to keep this force at the precise level for faithful tracking of the record grooves. It also has the job of switching the power on to the turntable.

- When the tonearm is moved from the arm rest to the platter, the power comes on, the strobe lamp lights up, and the platter rotates.
- When the tonearm is returned to the arm rest, the power to the turntable is cut off, the strobe light goes off, and the platter stops rotating.

⑦ ARM-ELEVATION LEVER

UP (▲): When this lever is set to this position, the tonearm will rise. Set it to UP before record play and when you want to stop record play while a track is being played or when you want to change over to a different track.

DOWN (▼): When the lever is set to this position, the tonearm will be lowered. If it is set to DOWN for record play, the tonearm will be lowered onto the surface of the record, and play will begin.

⑧ ANTI-SKATE KNOB

This knob is used to cancel out the harmful skating force which is generated during record play.

For further details, see "ANTI-SKATING ADJUSTMENT".

⑨ ARM REST/CLAMPER

The arm rest supports the tonearm when it is not being used. Set the tonearm on its rest when it is not playing records. Clamp it into position if you don't have any immediate plans to play records.

⑩ PLATTER/RUBBER PLATTER MAT

When the tonearm is moved and power is supplied to the turntable, the platter will start rotating at the set rotation speed. The rubber platter mat stabilizes the records and also absorbs external vibration.

⑪ DUST COVER

Keep this closed unless operating the controls or tonearm, or changing over records. This serves to keep dust from adhering to the records during record play. When fully opened and pulled straight up, this dust cover can be removed from the cabinet.

4. PL-300 PANEL FACILITIES

BEFORE CONNECTING, CHECK THE FOLLOWING:

- Switch the power to the amplifier off to prevent damage to the speaker system.
- The cartridge furnished with your turntable is an MM type. Be sure to use a stereo amplifier which has PHONO input jacks for this type of cartridge.

NOTE:
If you are using a low-output moving coil (MC) cartridge, you will need a special MC transformer or a head amplifier, or a stereo amplifier with a built-in MC amplifier.

CONNECTION PROCEDURE

1. Insert the phono cables (white and red) into the PHONO input jacks of the stereo amplifier (white for left channel into L jack, and red for right channel into R jack).

2. Connect the ground lead with the Y-shaped connector at the end to the ground terminal.
3. Insert the power plug into the convenience AC outlet of the amplifier or a wall outlet.

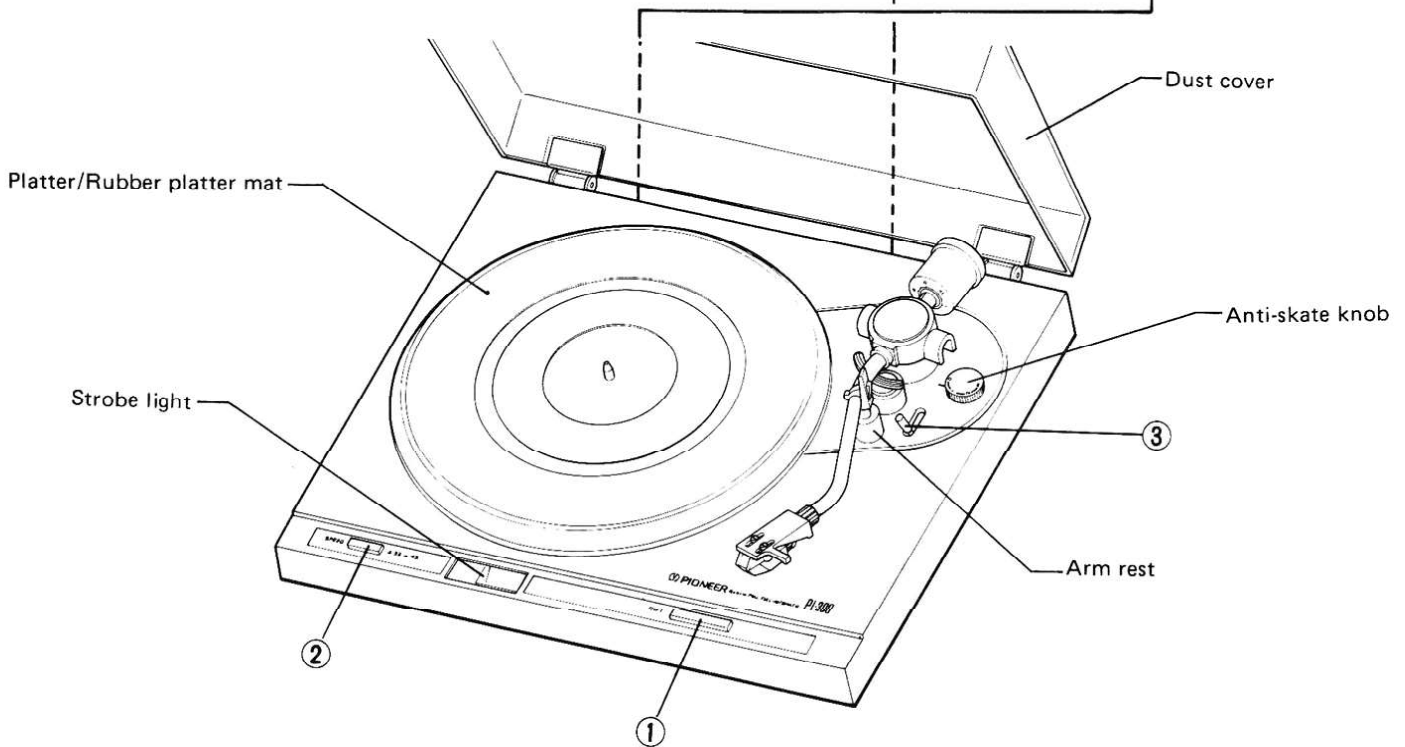
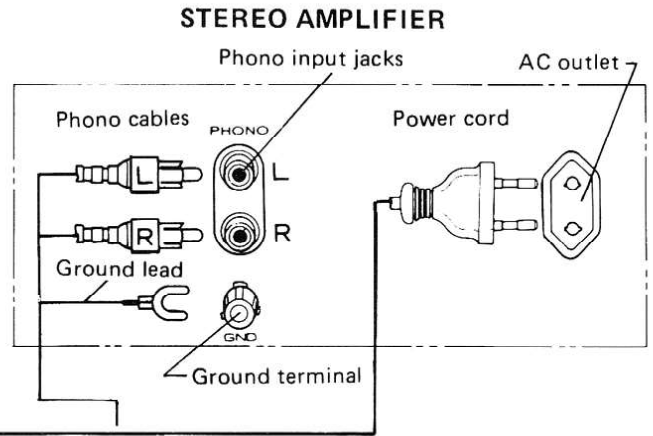

① CUT BUTTON

If this button is depressed while the record is playing, the tonearm automatically returns to the arm rest, and the power to the turntable is cut off.

② SPEED SELECTOR BUTTON

45 When this button is depressed, the platter will rotate at 45rpm. Depress for playing 45 rpm records, singles or EP's.

33 When this button is set to the released position, the platter will rotate at 33-1/3rpm. Release for playing 33-1/3rpm records like LP's.

③ ARM-ELEVATION LEVER

UP (▽): When this lever is set to this position, the tonearm will rise. Set it to UP before record play and when you want to stop record play while a track is being played or when you want to change over to a different track.

DOWN (▽): When the lever is set to this position, the tonearm will be lowered. If it is set to DOWN for record play, the tonearm will be lowered onto the surface of the record, and play will begin.

5. DISASSEMBLY

5.1 PANEL AND BASE PLATE

1. Undo the 4 screws ❶ securing the insulator legs.
2. Move the tonearm across to the center, and raise the panel a little.
3. Disconnect the D.D. motor and circuit board connectors (2-pin and 5-pin).

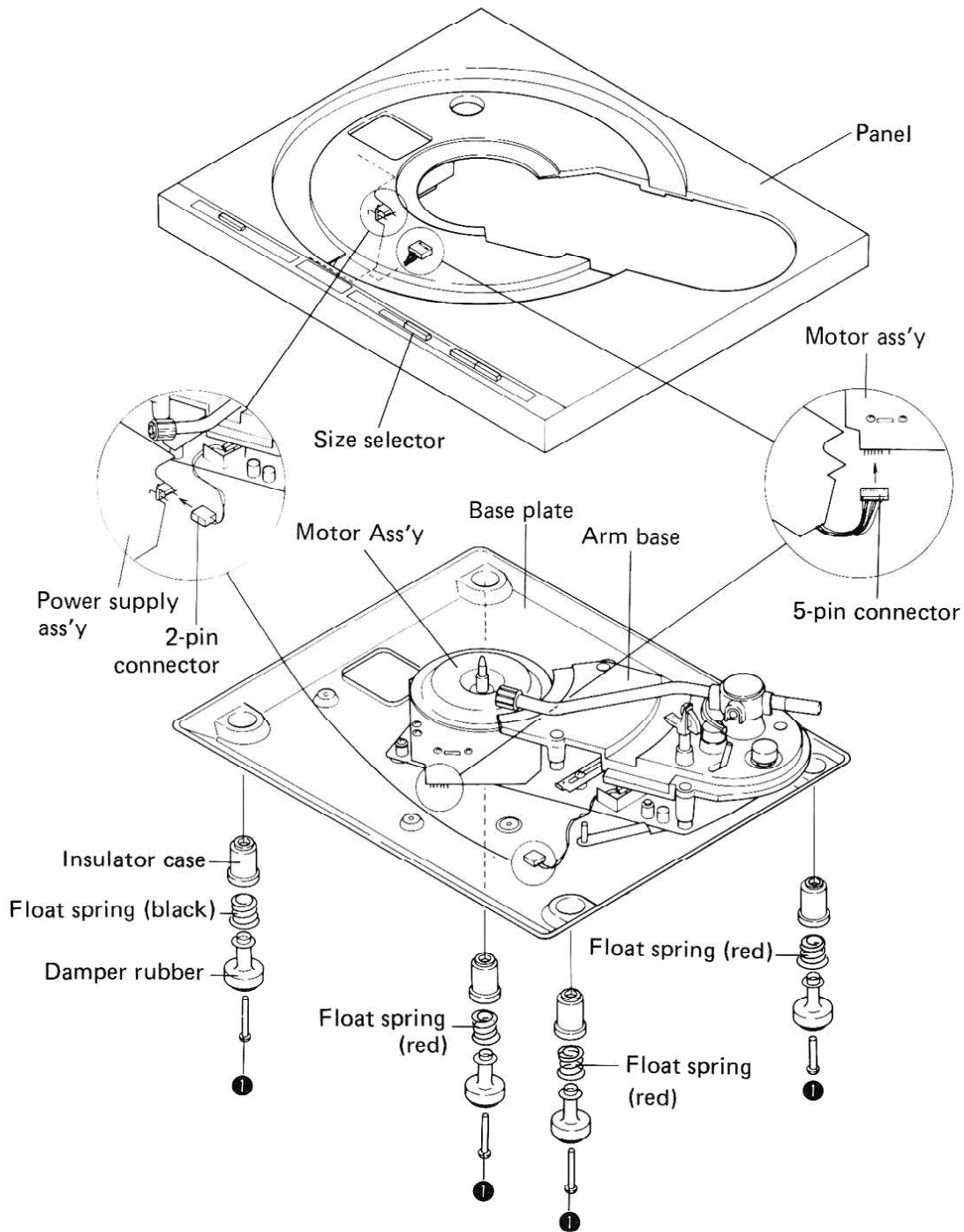

Fig. 5-1

5.2 D.D. MOTOR AND TONEARM

1. After removing the panel, undo the 3 screws ② securing the motor.
2. Undo the 4 screws ③ securing the arm base.

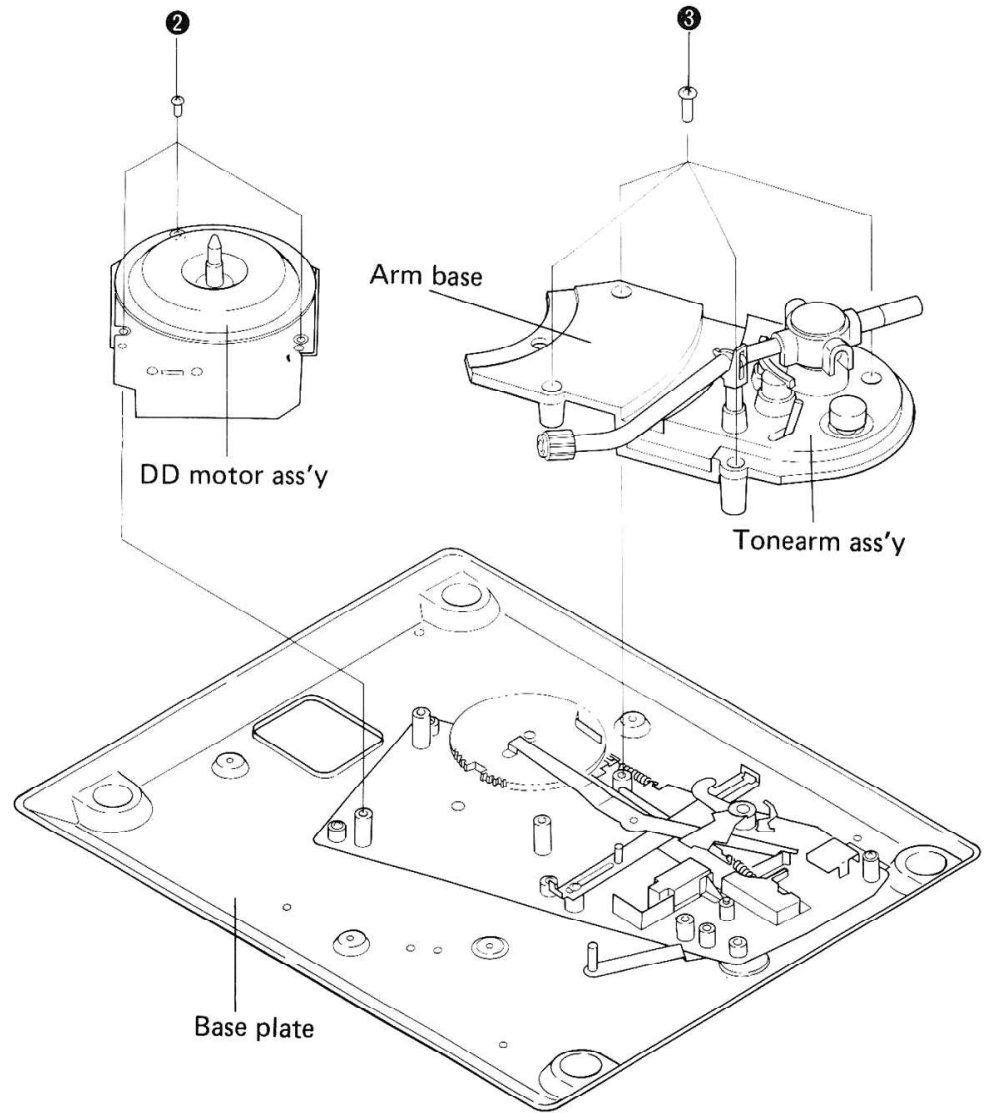

Fig. 5-2

6. PANEL AND BASE PLATE ASSEMBLY

6.1 PL-200, PL-300

1. Rotate the motor clockwise by hand to reset the motor mechanism.
 2. Move the tonearm across to the center (after removing the main weight and headshell).
 3. With the base plate half covered by the panel, connect the microswitch 2-pin connector to the power supply ass'y, and connect the power supply ass'y 7-pin connector to the motor ass'y. (See Fig. 1). Clamp all lead wires with cord clamps, and check that there are no other obstacles to normal operation of the mechanical parts.
 4. Shift springs A and B across to the left as shown in Fig. 3, spring A being positioned to the left of spring B. (When the cut button is pressed, spring A will snap back to the right hand side of spring B).
 5. Then cover the base plate completely by the panel, move the tonearm across to the arm rest and clamp it into position.
 6. Screw in the insulators (insulator case, float spring, and damper rubber) to secure the panel to the base plate.
- * The front left hand float spring differs from the other 3. Check that they are all correctly mounted as shown in Fig. 1.

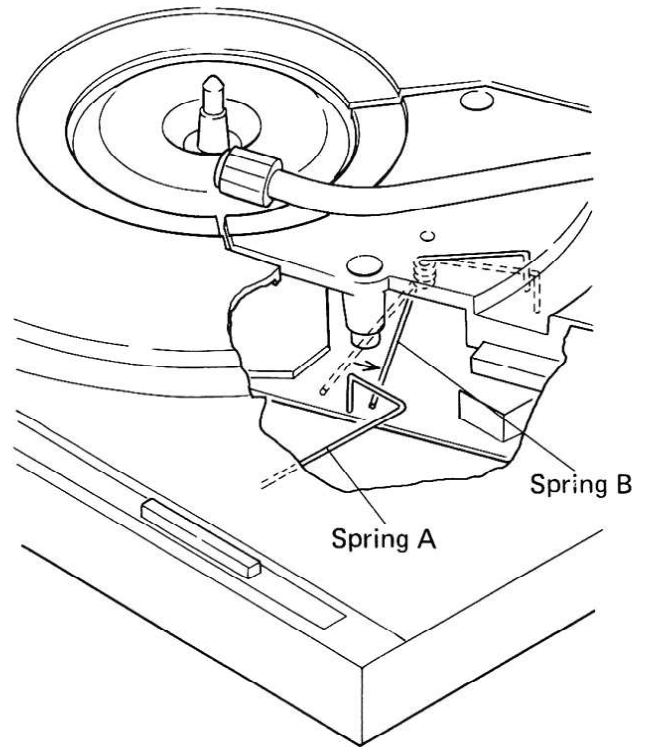

Fig. 6-1

6.2 PL-255, PL-400

1. Rotate the motor clockwise by hand, and check that the main mechanism has been reset to the stationary state.
2. Shift the tonearm across towards the center, and remove the main weight and headshell.

3. Attach spring A to the panel rib.
4. Set the size selector to the 30cm position, and attach spring B to the panel boss.

5. Connect the 2-p connector from the micro-switch to the power supply assembly, and the 7-p connector from the power supply assembly to the motor assembly.

Note that all lead wires should be carefully clamped into position at this time in order to avoid loose wires being damaged by mechanical operation.

6. Lay the panel on the under-base, and return the tonearm to the arm rest and clamp it into position.

7. Attach the insulators (case, float spring*, damper rubber), and secure the panel to the under-base.

*Note that the front left hand corner float spring differs from the other 3. Refer to Fig. 5-1 for correct mounting procedures.

8. Switch the size selector to the 25cm position, and release the arm lock.

9. Rotate the motor clockwise while pressing down on the center of the arm base, and check that the main mechanism has been rest to the stationary state. During this operation, spring B and lever A will engage each other as shown in Fig. 6-3.

10. When the start button is then pressed, spring A will be released from the rib to engage the pin on lever D.

This then completes the assembly of the panel and base plate.

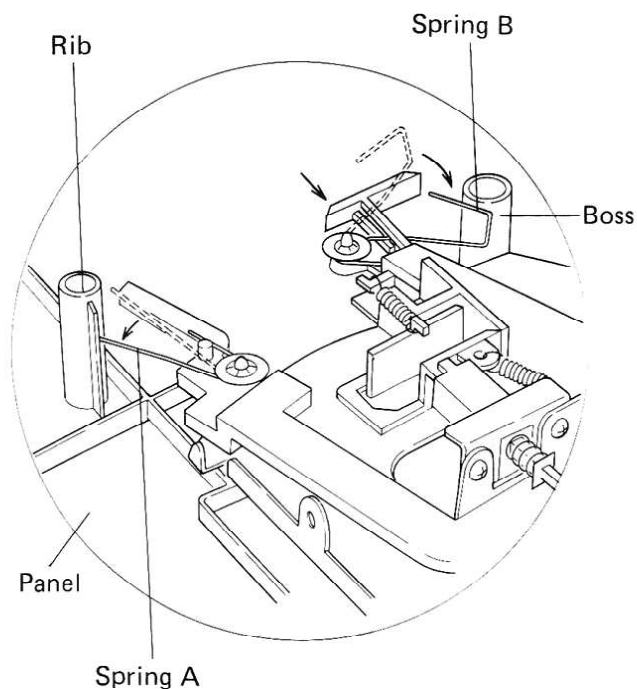

Fig. 6-2

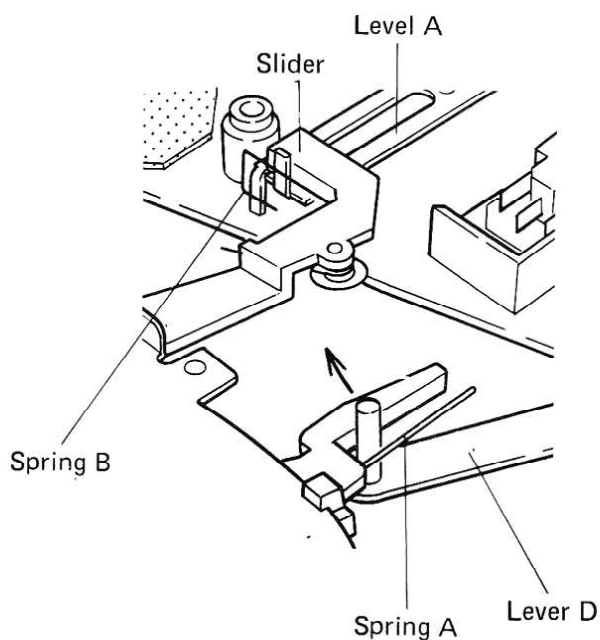
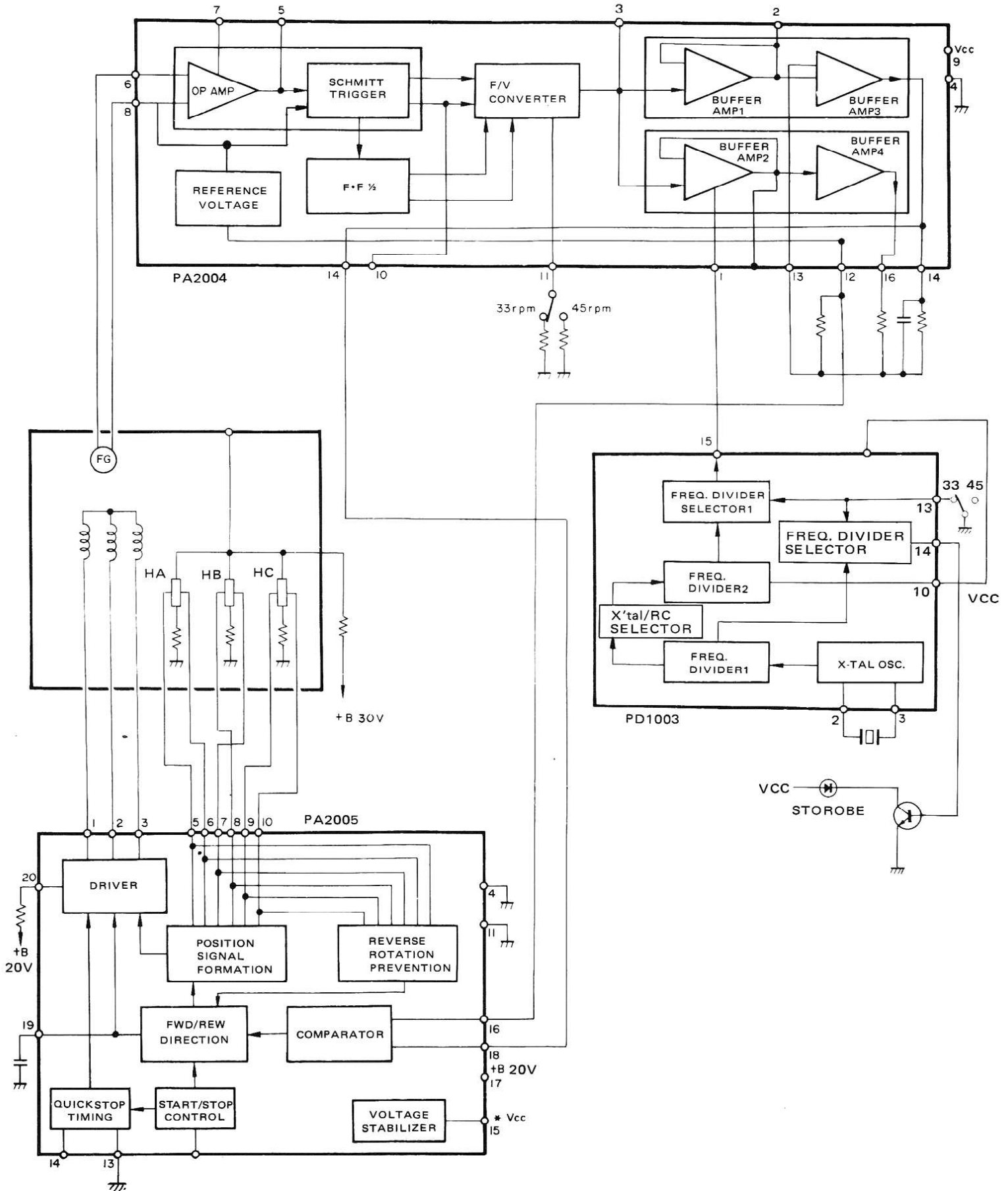

Fig. 6-3

7. CIRCUIT DESCRIPTIONS

7.1 BLOCK DIAGRAM (PL-300, PL-400)



7.2 MOTOR OPERATION

1 Motor Construction

1. These motors are flat type 8-pole 6-coil slotless Hall motors.
2. Besides the 3-phase Y-connected windings, each motor is equipped with 3 phase-detector Hall elements positioned at intervals 60° apart.
3. These Hall elements generate Hall voltages which vary in level according to strength and direction of magnetic flux changes induced by the rotating rotor.
4. An independent FG magnet used to detect speed changes has been positioned on the outside of the rotor magnet. This FG magnet has been designed with 200 magnetic poles, and rotates opposite a printed coil mounted on part of the circuit board. As the magnet rotates an AC current signal is generated and is used for speed detection purposes.
5. As can be seen in Fig. 7-1, the rotor magnet generates an 8 polar trapezoidal magnetic wave, and by phase additions of the coil switching waveforms a even torque is obtained.

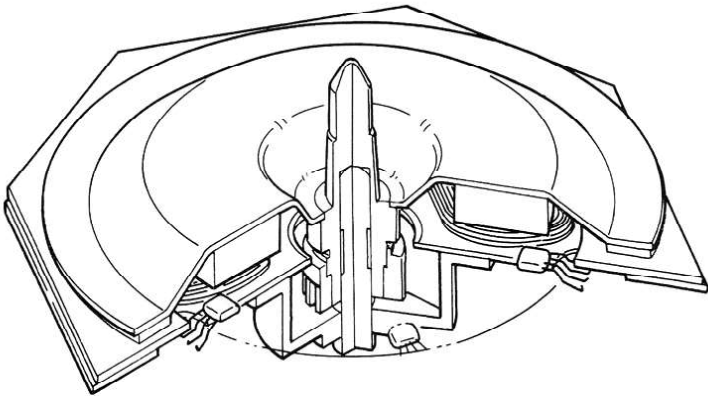

Fig. 7-1

2. Principle of Motor Rotation

1. Assume that the rotor has stopped at the position as shown in Fig. 7-2.
2. In this position, Hall element HA is located half way between an S pole and N pole on the rotor, while HB and HC are opposite an N pole and S pole respectively.

3. If the power is then turned on, the Hall element outputs will be as indicated in Fig. 7-8.
4. The Hall element outputs are applied to the position signal forming circuit (PA2005A), resulting in the switching of the current flowing through the drive coils.
5. These Hall element outputs are generated by the rotational action of the rotor as shown in Fig. 7-9.
6. These signals are thus used in switching the drive circuit (also in PA2005A) to change the direction of current flow in the coils, and thereby determine whether an N or S pole is generated, or whether the coil is switched off.

In actual rotation, this happens as follows.

7. As the rotor side of coil L_A becomes a south pole, that of L_B becomes north, and L_C , neutral.
8. Repulsion between the S pole at L_A and the rotor S pole, and attraction between the L_B N pole and the rotor S pole exert a propulsive force on the rotor.
9. As the rotor turns through 15° of arc, the output from the Hall elements changes.
10. L_B now enters OFF state, L_C becomes a N pole, and L_A a S pole.
11. The L_C N pole now attracts the rotor S pole, and the L_A S pole attracts the rotor N pole. Rotation continues.
12. Correspondences between rotor positions and coil polarities are shown in Fig. 7-3, a-f.

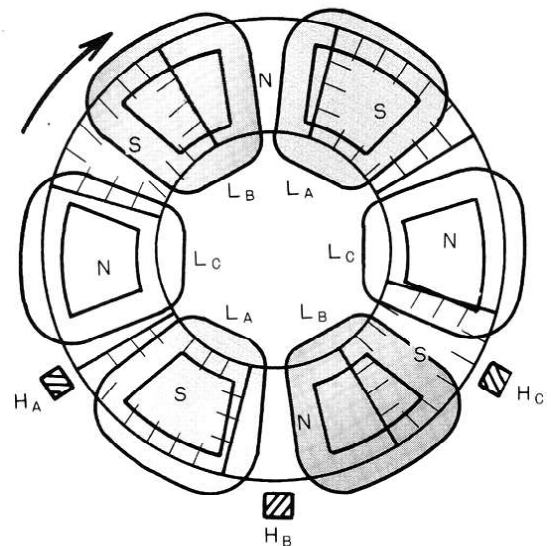

Fig. 7-2

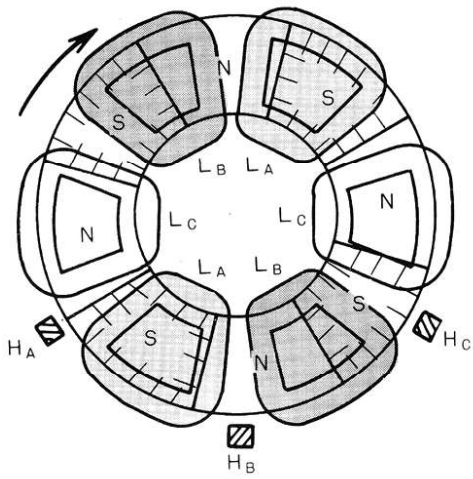

Fig. 7-3-a

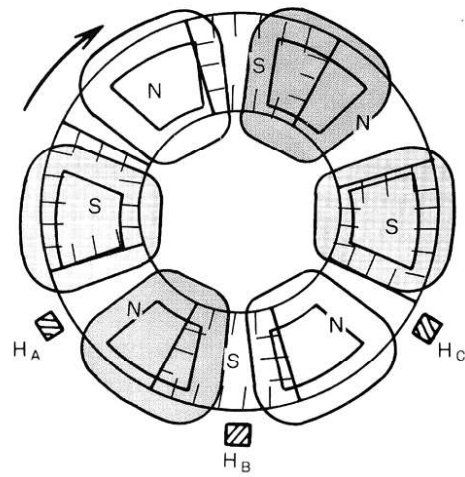

Fig. 7-3-e

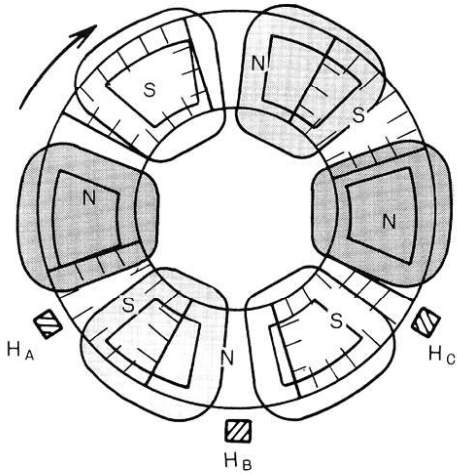

Fig. 7-3-b

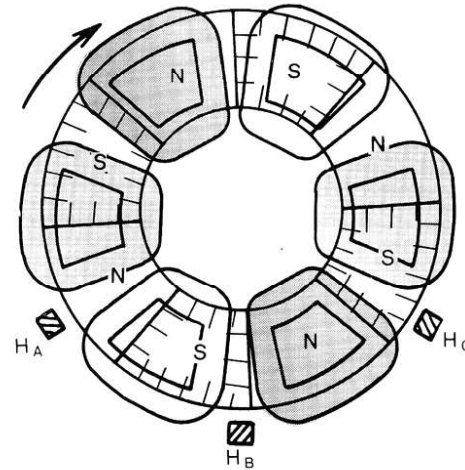

Fig. 7-3-f

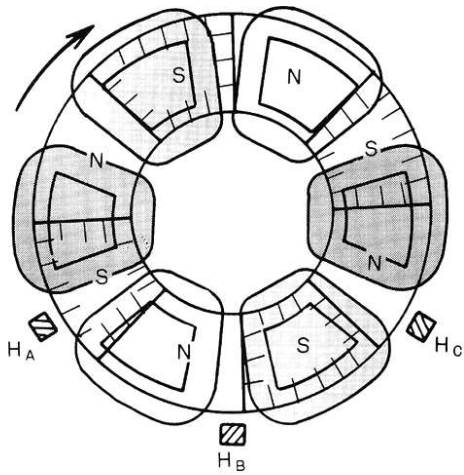

Fig. 7-3-c

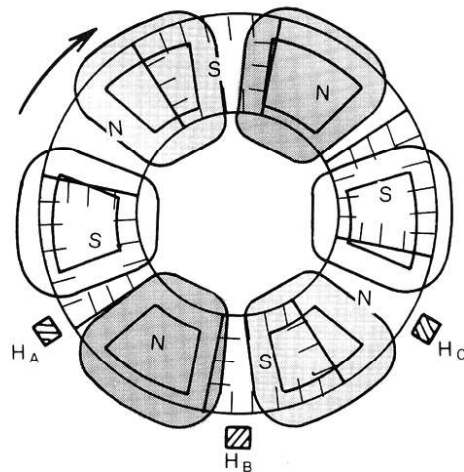

Fig. 7-3-d

3. Speed Detection Section

1. The speed detection plate has one rows of "detection patterns."
2. The bottom surface of the rotor is magnetized with 200 magnetic poles, and these rotate at a short distance above the speed detection plate.
3. The output voltage from the detection patterns has a frequency of 55.5Hz at 33-1/3 rpm, and of 75Hz at 45 rpm.
4. The signal is supplied to IC PA2004.

7.3 OPERATION OF THE PD1003 IC (OSCILLATOR STAGE)

1. Once the power supply is turned on, the quartz crystal oscillator generates a 6144kHz signal.
2. The frequency of this signal is reduced to 1.5kHz (1/4096 division) by frequency divider I. Part of the resultant signal is passed via the x'tal/RC switching circuit and applied to frequency divider II. The other part of the signal is applied to frequency divider selector II.
3. The 1.5kHz signal applied to frequency divider II is further divided into a 750Hz signal, and applied to frequency divider selector I where the signals are converted into sampling pulses for phase comparison purposes in PA2004.

33rpm 27.78Hz

45rpm 37.5Hz

(In both cases, the pulse width is 0.667ms).

4. Frequency divider selector II converts signals from frequency divider I into pulse signals for the stroboscope lamp drive circuit.

33rpm 55.5Hz

45rpm 75.0Hz

(In both cases, the pulse width is again 0.667ms).

NOTE:

This IC (PD1003) is not employed in the motor of the PL-200 and PL-225 models.

7.4 OPERATION OF THE PA2004 IC (COMPARATOR CONTROL)

1. Signals from the frequency generator in the motor rotation ass'y are changed into 50% duty square wave signals by the waveform rectifier. The frequencies at this stage are thus,
33rpm 55.55Hz
45rpm 75Hz
2. Part of the output is divided by $\frac{1}{2}$ in the FF circuit, and subsequently applied to the FV converter circuit along with the other part of the output formed in step 1 above, thereby forming the FV converter gate pulse signals.
3. The output from the FV converter is applied to buffer amplifiers I and II.
4. The buffer amplifier I output is compared with the reference voltage in buffer amplifier III, and then applied to the output compose circuit.
5. Phase comparison of the sampling pulses from the PD1003 IC with the FV converter output occurs in buffer amplifier II, with the resultant output being applied to buffer amplifier IV.
6. The output from buffer amplifier IV is also applied to the output compose circuit.
7. This output compose circuit consists of a low-pass filter (cut-off frequency 23Hz, cut-off slope -6dB/oct.) which serves to eliminate the carrier component in the output of buffer amplifier II (phase comparison).
8. This final output signal is then passed onto the comparator control stage of the PA2005 IC for comparison with the reference voltage.

7.5 OPERATION OF THE PA2005 IC (DRIVE CONTROL)

● Stroboscope Pulse Circuit

1. The platter has only a single row of stroboscopic markings. Switchover for 45 and 33 rpm is effected by changing the frequency of the pulse to the stroboscopic lamp.
2. From the Frequency Divider Selector I, a frequency of either 75Hz (for 45 rpm, representing 1/80 of 6000Hz) or 55.5Hz (for 33 rpm, representing 1/108) is obtained and supplied to the transistor that drives the stroboscopic lamp.

● Reverse Rotation Prevention

1. This motor operates indiscriminately in regard to the direction of rotation. If the platter is turned slowly in the reverse direction by hand, a forward torque will be applied until the platter stops, reverses its rotation and reaches rated speed in the proper direction.
2. If, however, the rotational speed in the reverse direction is in excess of 33 or 45 rpm, the Forward/Reverse Command Block may "mis-read" this as simply excessive speed ("overrun") and apply a reverse torque until rated speed is attained.
3. This reverse torque will further accelerate the turntable rotation in the reverse direction. This is known as "reverse run-away."
4. To prevent this from happening, a Reverse Rotation Prevention circuit has been included.
5. This Reverse Rotation Prevention circuit consists of two flip-flops and AND gates See Fig. 7-4.
6. The input for this circuit is derived from the Hall element position detection signals processed in the Reverse Rotation Prevention circuit.
7. As long as the platter is rotating in the proper direction, this pulse enters in the order B — A — C, and no "reverse" command is generated.
8. If, however, the platter rotates in the reverse direction, the pulse order becomes A — B — C, and a corrective command is given to the Forward/Reverse Command Circuit.

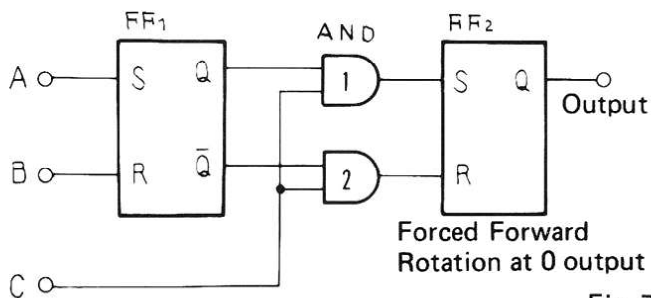

Fig. 7-4

		FF ₁				C	AND		FF ₂
		S	R	Q	\bar{Q}		1 _{out}	2 _{out}	Q
Forward rotation	B	0	1	0	1	0	0	0	—
	↓								
	A	1	0	1	0	0	0	0	—
Reverse rotation	↓								
	C	0	0	1	0	1	1	0	1
	↓								
	A	1	0	1	0	0	0	0	—
Reverse rotation	↓								
	B	0	1	0	1	0	0	0	—
	↓								
C	0	0	0	1	1	0	1	0	

Truth table

● Comparator Control and Forward/Reverse Command Circuit

1. Two inputs are supplied to the Control Comparator: a) a 4V reference voltage from the voltage stabilizer; and b) the output from the active filters, which serves as the detection signal.
2. If the turntable rotates faster than rated speed, the detection signal is higher than the 4V reference.
3. When this happens, the Comparator Control sends a command to the Forward/Reverse Command Circuit, telling it to apply a reverse torque to the motor to slow it down.
4. Conversely, if turntable rotation is below rated speed, the detection signal voltage will be below the 4V reference.
5. In this case, the Comparator Control indicates to the Forward/Reverse Command Circuit that forward torque must be applied to the motor to accelerate it.

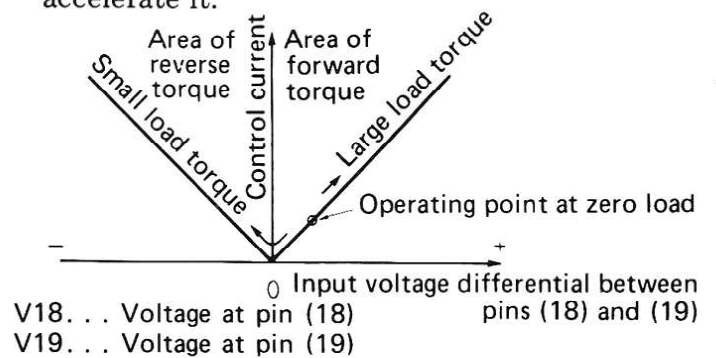

Fig. 7-5

● Drive Circuit

1. The signals employed in the switching of Q2 ~ Q7 in Fig. 7-6 are generated by 3 Hall elements, and applied to terminals a, b, and c via the position signal formation circuit.
2. The phase of these step waveform signals is displaced by 120° from each other.
3. When the step waveform signals at position I in Fig. 7-7a are applied to the drive circuit terminals a, b, and c, the potential at terminal a will be lowered, resulting in Q2 being turned on. The potential at terminal b will be raised, resulting in Q6 being turned on, but the potential at terminal c will remain at the reference level voltage (the bias settings for Q4 and Q7 have been designed to prevent these 2 transistors from operating when a reference level voltage is applied).
4. Vcc will thus be applied across the Q2 – coil L_A – coil L_B – (2) – Q6 route, thereby producing an S polarity in L_A, and an N polarity in L_B.
5. Once the magnetic field is generated, the rotor will commence to rotate. After the rotor turns through 15°, the signals at position II in Fig. 7-7b will be applied to terminals a, b, and c, thereby resulting in a change in the flow routes of the drive currents. After the rotor turns through another 15°, the signals shown at position III in Fig. 7-7-c will be applied, again resulting in changes in flow routes of the drive currents. For every 15° that the rotor turns through, the flow routes for the drive currents will change as shown in Figs. 7-7d, 7-7e, and 7-7f, finally returning to the routes shown in Fig. 7-7a again.
6. A control voltage generated by the forward/reverse direction discriminator indicator circuit is applied to the control input terminal, thereby controlling the flow of current in the coils.

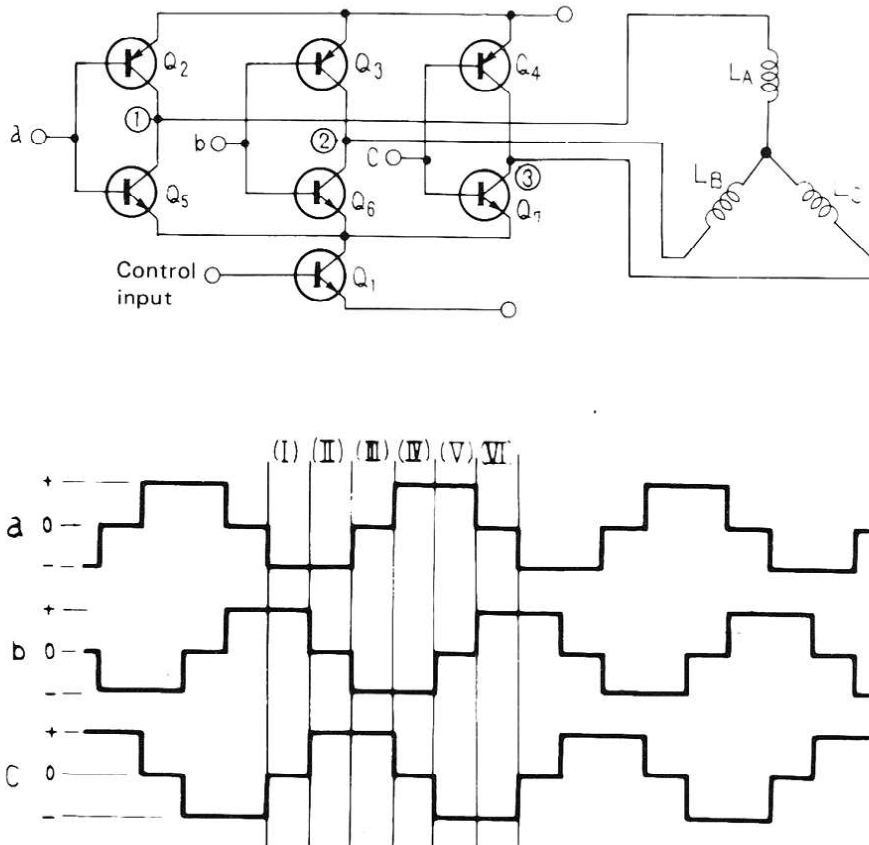

Fig. 7-6

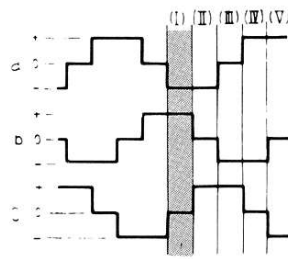
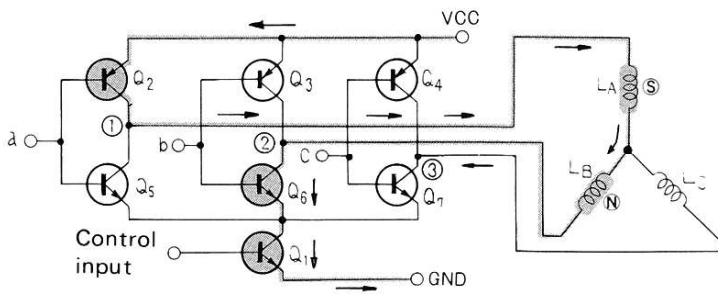

Fig. 7-7-a

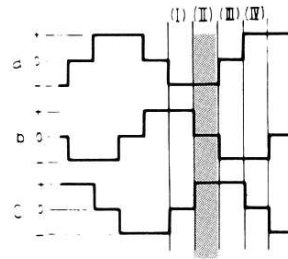
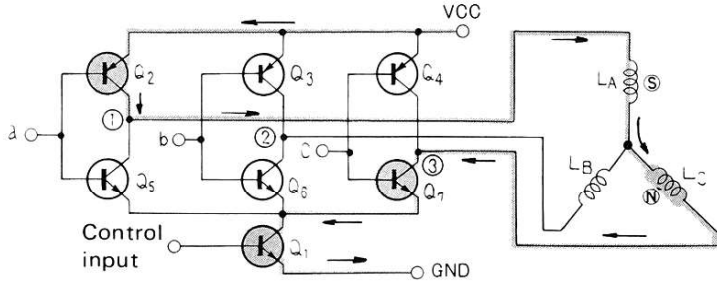

Fig. 7-7-b

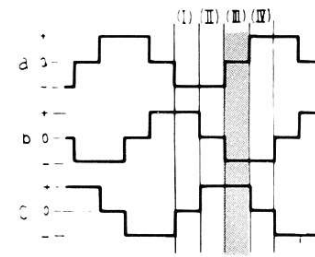
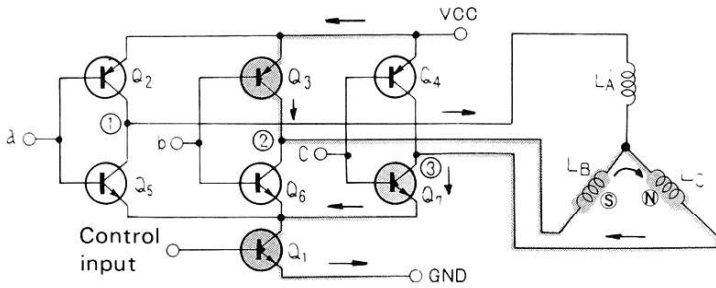

Fig. 7-7-c

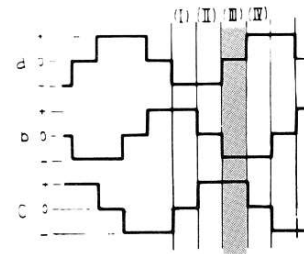
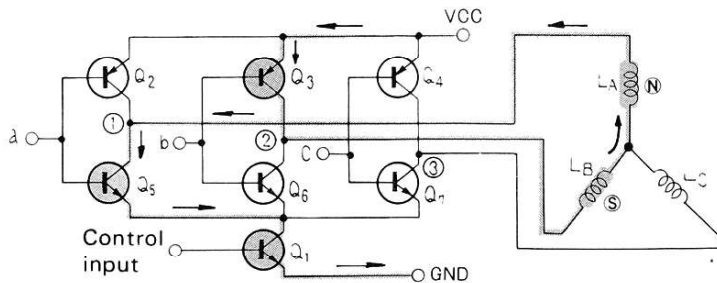

Fig. 7-7-d

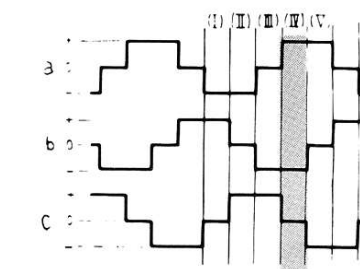
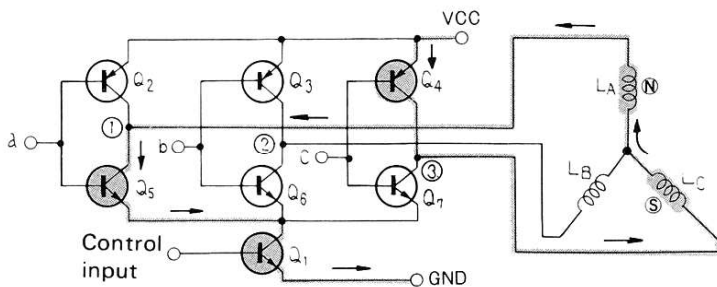

Fig. 7-7-e

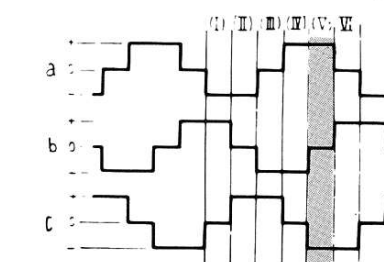
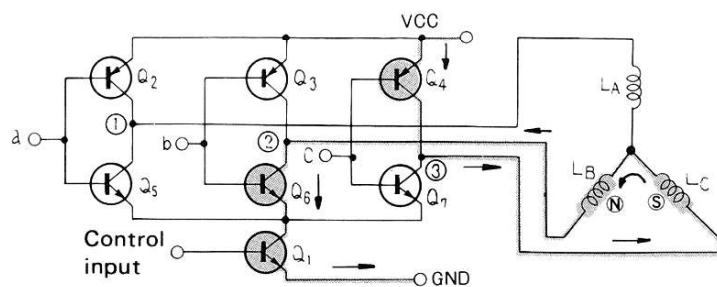
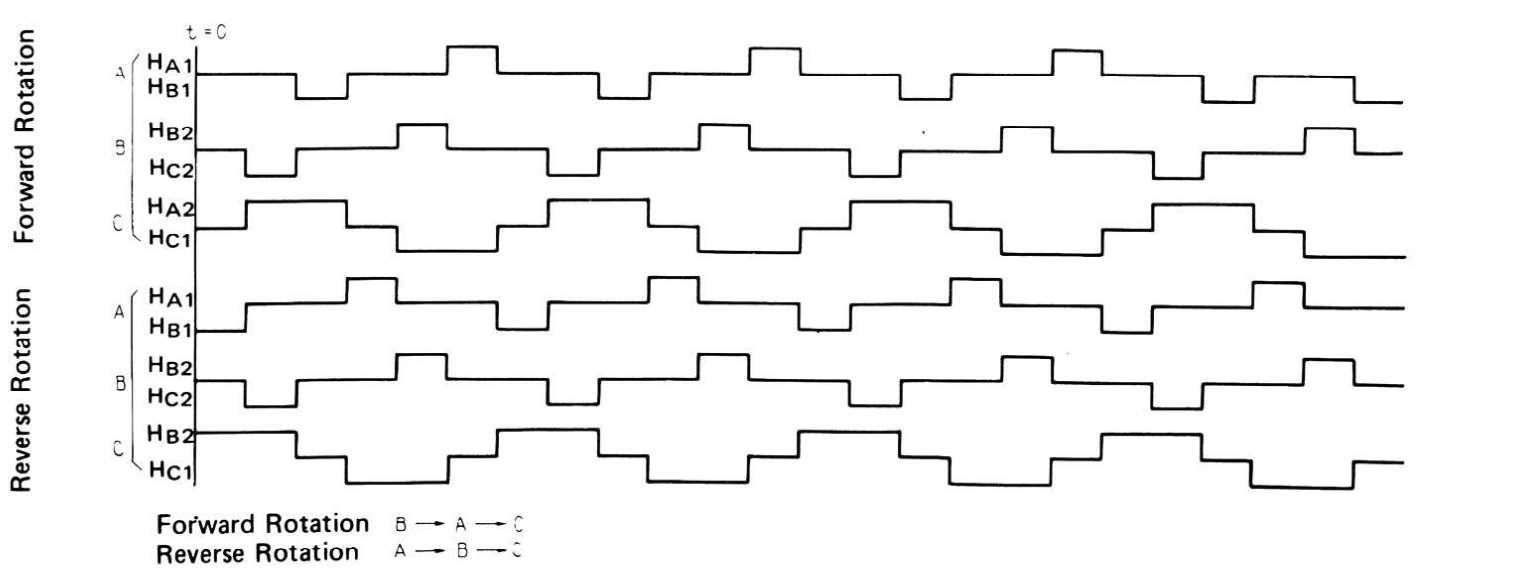
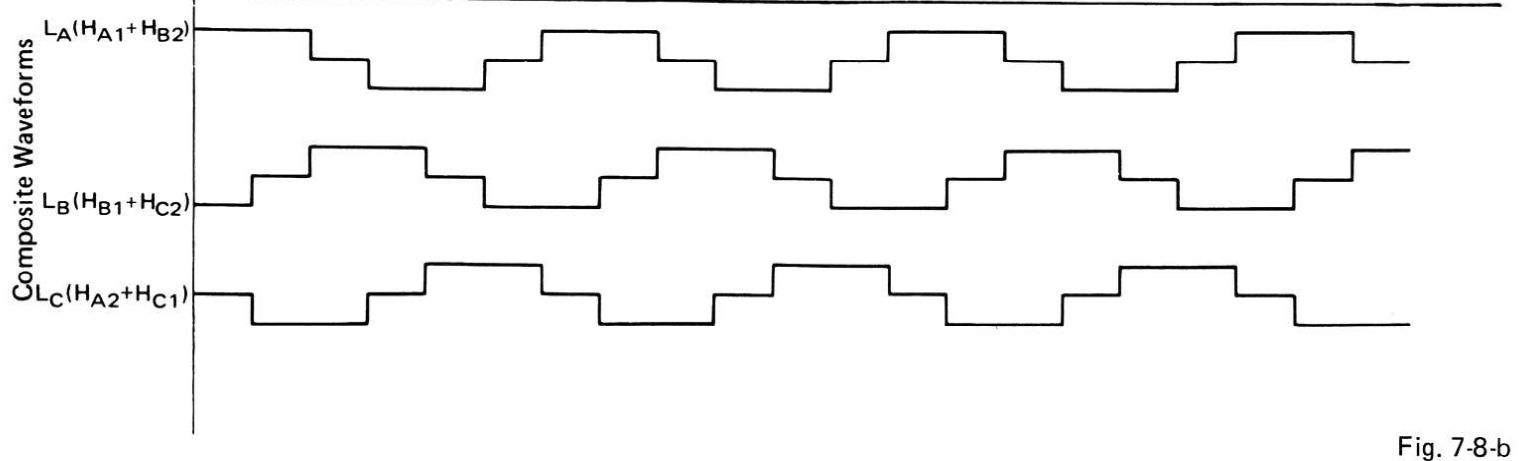
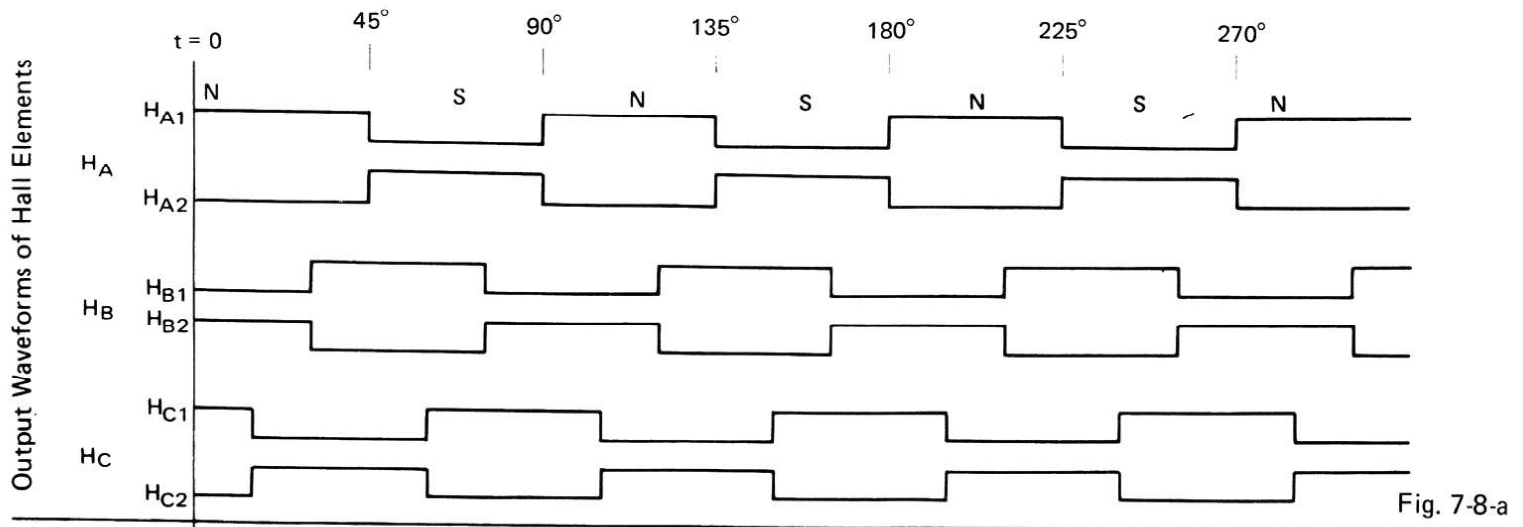

Fig. 7-7-f



7.6 BLOCK DIAGRAM (PL-200, PL-255)

NOTE:

The DD motor employed in the PL-200 and PL-300 models operates in much the same way as the DD motor in the PL-255 and PL-400 models. See pp.14~20 for details.

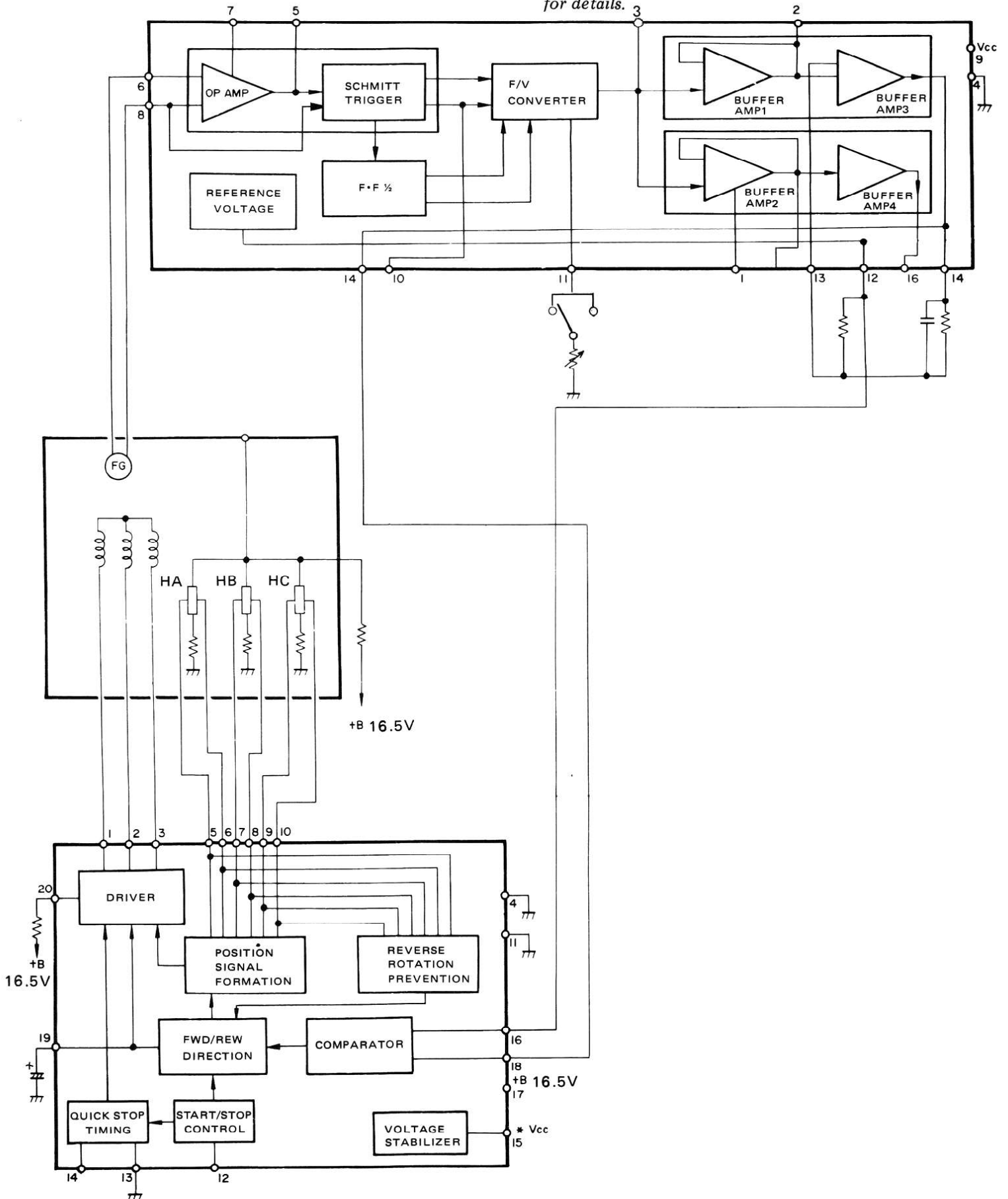

8. MECHANISM DESCRIPTIONS

8.1 PL-200 MECHANISM OPERATING

The PL-200 is equipped with auto-return only. Fig. 8-1 shows the PL-200 in the stationary state with the tonearm back in the arm rest.

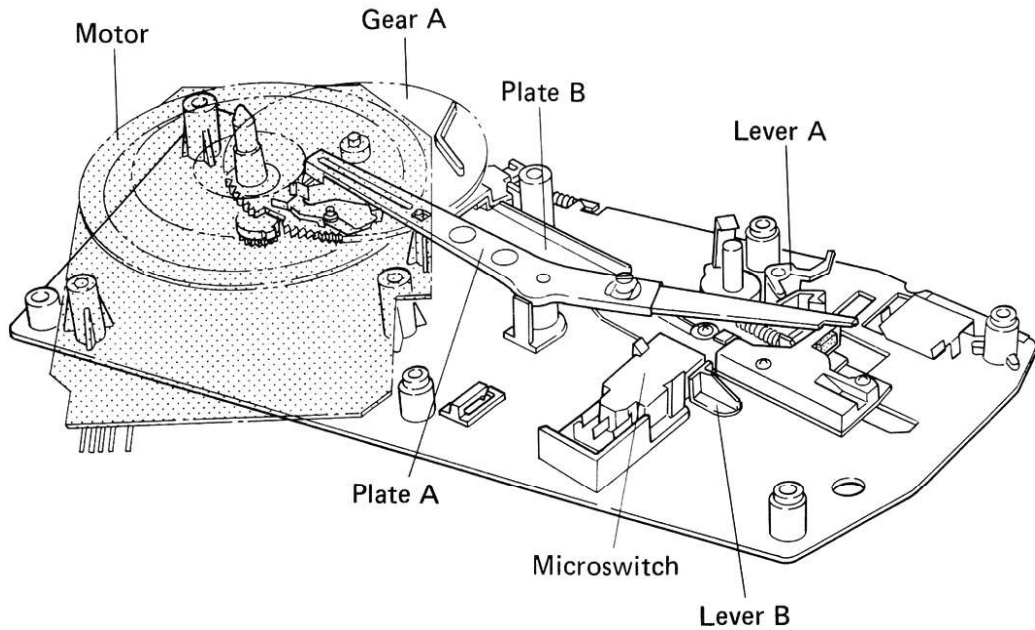

Fig. 8-1

* START OF PLAY

1. When the tonearm is moved across to the disc, the PU plate located below in the arm base is also moved.
2. Lever A is moved over by pin A connected to this PU plate, resulting in lever B being unlocked.
3. At the same time that lever B is unlocked, the microswitch is turned on (power on), and the motor commences to rotate.

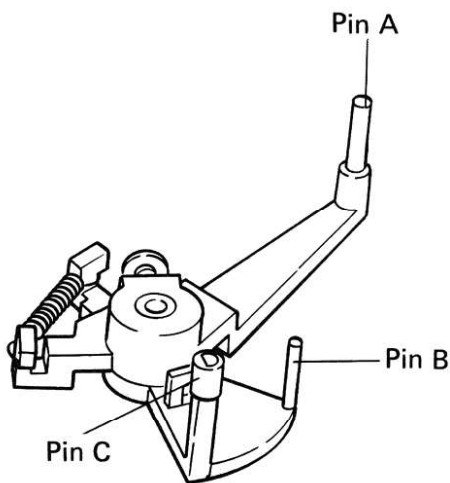

Fig. 8-2

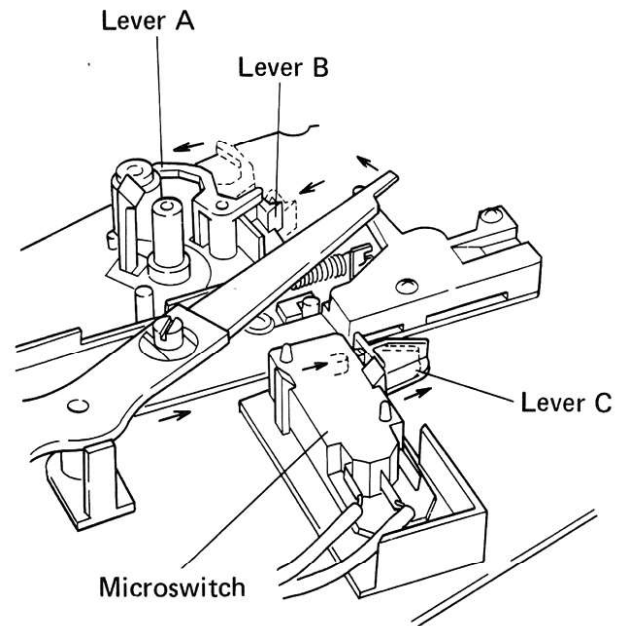

Fig. 8-3

* AUTO-RETURN

1. When the stylus enters the disc lead-out groove and the auto-return detector mechanism is activated, the claw of the detector mechanism catches the projecting part of gear B on the center shaft, resulting in gears A and B engaging each other and gear B consequently rotating in the counter clockwise direction.
2. Plate B is then shifted across towards the tone-arm due to the groove in the underneath of gear A.
3. The edge of plate B pushes against lever C to force the arm elevation upwards.
4. Plate B continues to shift across to push against pin B on the PU plate, thereby returning the tonearm back to the arm rest.
5. At this stage plate B commences to return towards the center shaft guided by the groove in gear A.
6. When the edge of plate B separates from lever C, the arm elevation is lowered to drop the tonearm back into the arm rest.
7. And at the same time that the tonearm is returned to the arm rest, pin A returns lever A back to the stationary state.
8. Plate B continues to move towards the center shaft and pushes against pin C on lever B. Lever B thus switches the microswitch off (power off), and is then locked by lever A, thereby bringing a complete operation cycle to an end.

*For details on the operational principles involved in the auto-return detector mechanism, refer to the PL-516 Service Manual (ART-279).

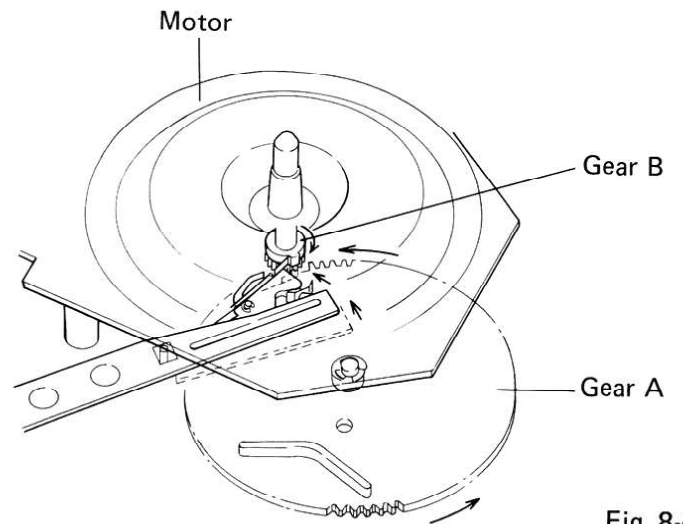

Fig. 8-4

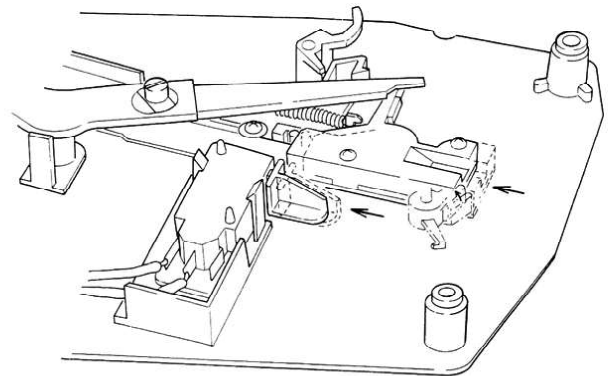

Fig. 8-5

8.2 PL-400 MECHANICAL OPERATION

* LEAD-IN

Fig. 8-6 shows the PL-400 in the stationary state with the motor stopped and the tonearm upon the arm rest.

1. When the START/STOP button is pressed, lever D will be shifted towards the left by spring B of lever F (Fig. 8-6).
2. Pin A located above lever D then presses against plate C, thereby unlocking plate C from lever C. And once lever C is separated from the micro-switch the power for the motor will be turned on (Fig. 8-7).
3. The plate C plate spring will also press against lever A, thereby repelling the cam A detector assembly (Figs. 8-7, 8).
4. Once the motor commences to rotate, the motor pinion gear (gear B) catches the claw of the detector assembly, and gear A and gear B engage each other, resulting in gear A rotating in the counter-clockwise direction (Fig. 8-8).
5. And since gear A commences to rotate, plate A moves towards the tonearm, resulting in the plate A projection (point A) being pressed against cam B to turn the plate in the counter-clockwise direction (Fig. 8-9).
Plate A makes a round trip by tracing the heart shaped groove formed in the underneath of gear A.

6. When cam B rotates counter-clockwise, lever B is moved forwards by spring action (in the direction of the arrow). And while plate A is being moved across to the tonearm, lever B is being pulled forwards to reach the state shown in Fig. 4. The slider stops at the position selected by the size selector. And although cam B continues to press against lever A, excess stroke action by lever B at this time is absorbed by the flexible spring.

When plate A moves towards the tonearm, cam C fixed to the right hand of plate A presses against cam D attached to the arm base (Fig. 8-10). Cam D thus rotates in the clockwise direction, thereby lifting the arm elevation, and resulting in the raising of the tonearm.

8. Just before plate A completes its movement across towards the tonearm, pin C of the PU plate is clasped by the lead-in latch due to the action of the hole in the sub-panel unit (Fig. 8-10). And when plate A commences to return towards the center shaft, the PU plate moves in a clockwise direction, thereby carrying the tonearm across to the record.
9. When plate A commences to return towards the rear, lever B is also pulled back by the action of spring A, and stops when it meets the slider. Cam B is also brought to a stop by this action (Figs. 8-9, 11).

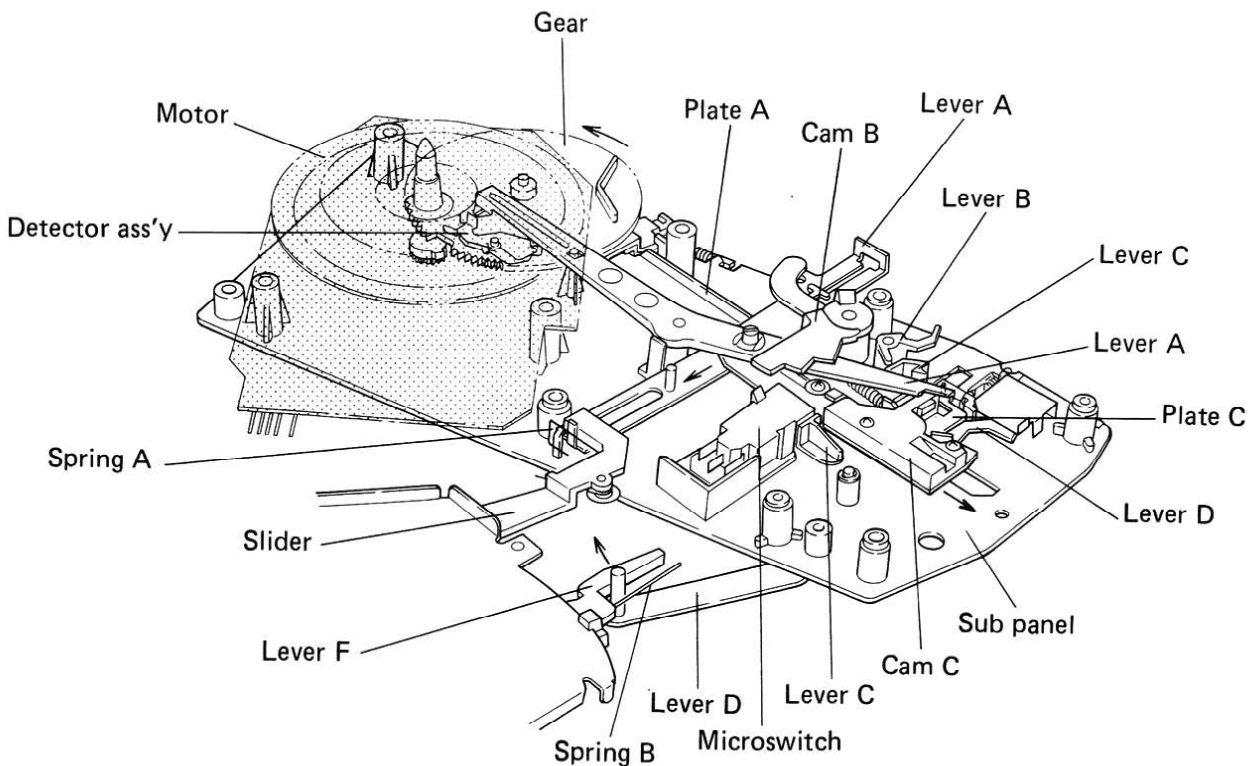

Fig. 8-6

10. The PU plate led in by the lead-in latch also stops when it meets cam B (Fig. 8-11). Then when plate A returns further, the lead-in latch is opened by the action of the sub-panel unit hole, resulting in the release of pin C on the PU plate (Fig. 8-13).

The position where the PU plate stops corresponds to the position set by the disc size selector.

11. As plate A returns towards the center shaft, cam D is released from cam C, thereby lowering the arm elevation to commence record play.

12. Then when plate A returns further towards the center shaft, cam B is rotated clockwise by the projection on plate A, and lever A is returned towards the rear. Lever A and cam B are thus returned to their original positions to permit the tonearm free movement.

13. Furthermore, plate C presses pin A on lever D across to the left hand side, thereby returning lever D back to its position prior to starting.

14. Lever A is set by striking against the projection on gear A.

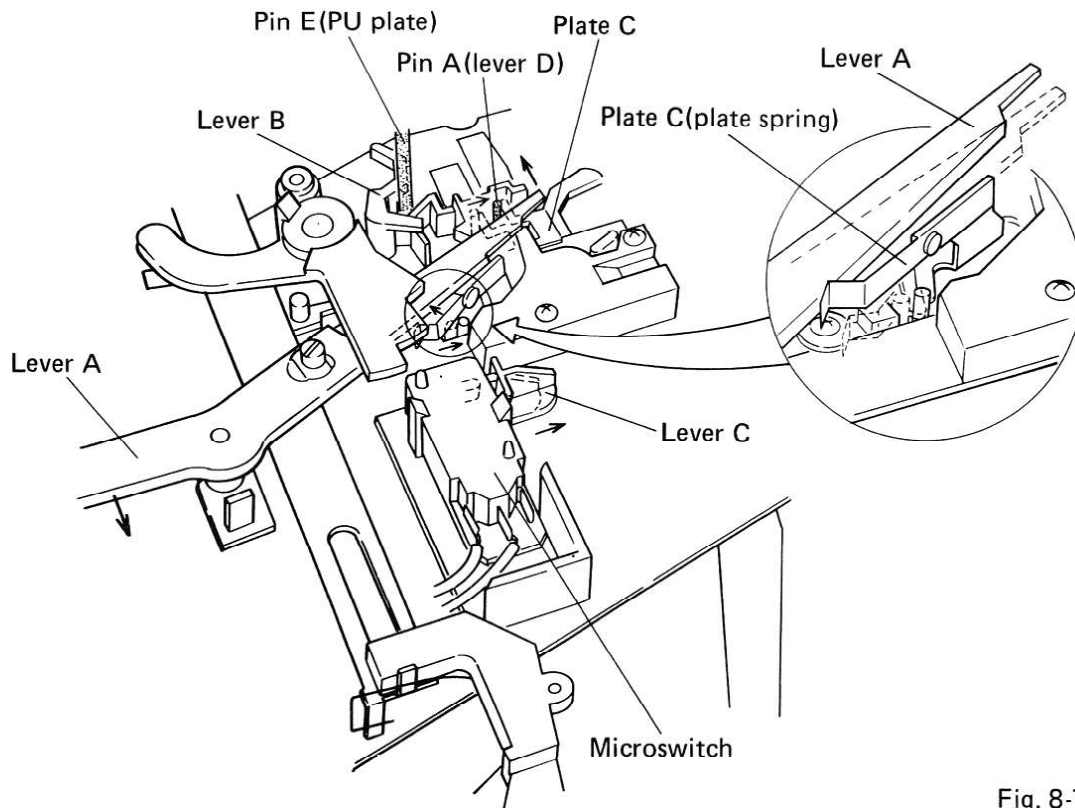

Fig. 8-7

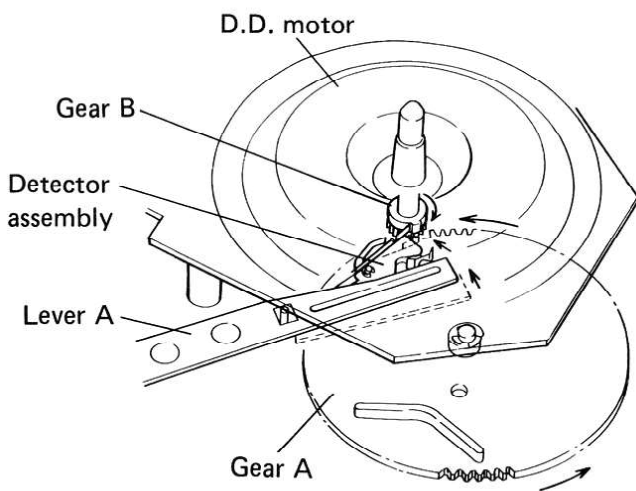

Fig. 8-8

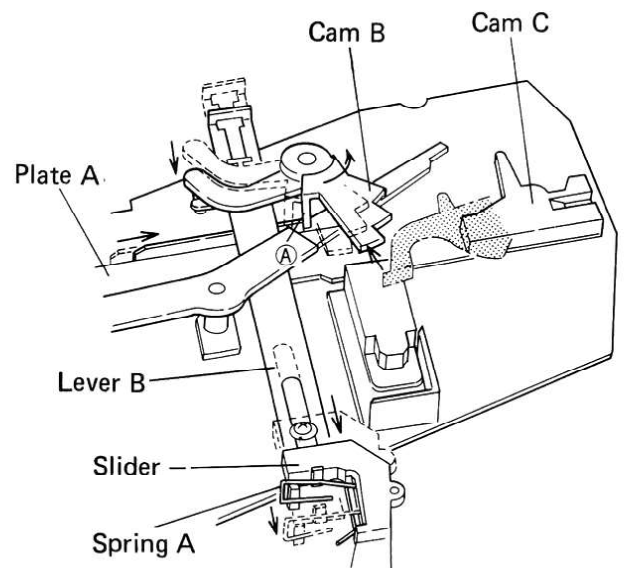

Fig. 8-9

15. When the PU plate completes the lead-in operation, pin E of the PU plate rotates lever E in the counter-clockwise direction, resulting in lever C separating from the microswitch to leave the motor power on for continued disc play (See Fig. 8-7).

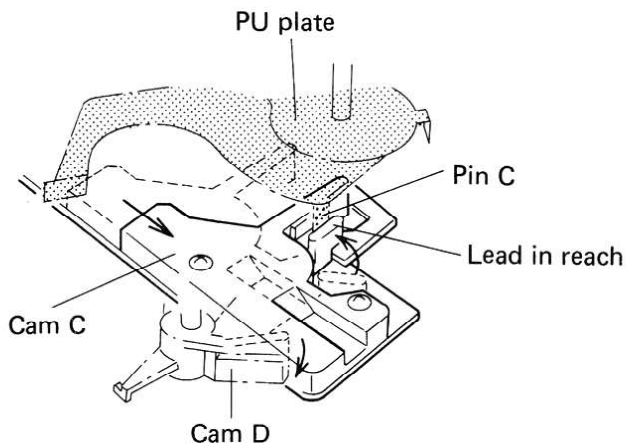

Fig. 8-10

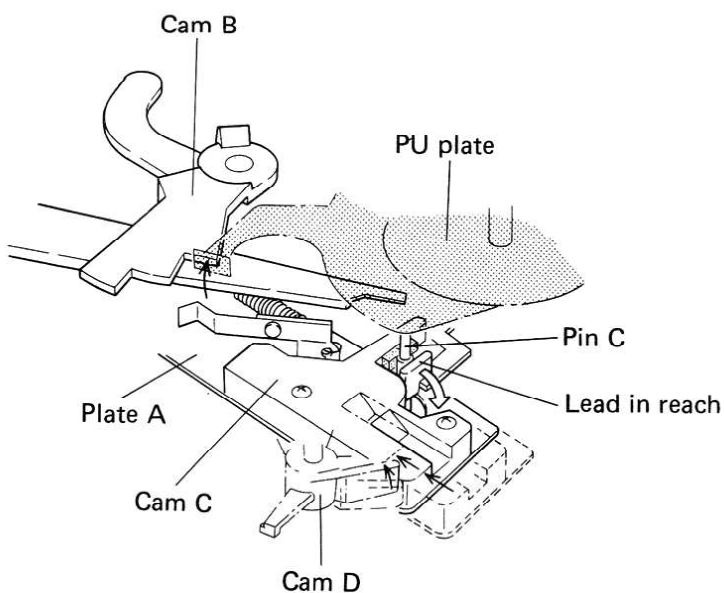

Fig. 8-11

• AUTO-RETURN

1. When the stylus enters the lead-out groove at the end of the disc, the end of the paly is detected by the detector assembly.

*For details on the operational principles involved in the auto-return detector mechanism, refer to the PL-516 Service Manual (ART-279).

2. When the claw of the detector assembly catches the motor pinion gear (gear B), gear A commences to rotate. Subsequent operation is the same as during lead-in.

3. When gear A commences to rotate, plate A moves towards the tonearm.
4. Cam C then presses against cam D attached to the arm base, resulting in the arm elevation being raised.
5. Cam C pushes pin C of the PU plate across to the arm rest position. Pin E also moves at the same time, rotating lever E in the clockwise direction. Lever E thus pushes lever C to the right.
6. Just before plate A reaches the end of its movement across towards the tonearm, pin C of the PU plate is clasped by the lead-in latch due to the action of the sub-panel unit hole.
7. When plate A starts to return towards the center shaft, the lead-in latch holding pin C is opened again by plate D, thereby releasing pin C to permit the tonearm to return the arm rest (fig. 8-13).
8. As cam C returns to the left hand side, cam D disengages cam C, resulting in the arm elevation being lowered to drop the tonearm back into the arm rest.
9. When plate A approaches its original position, plate C is pushed to the left by cam C fixed to plate A, resulting in the microswitch being turned off by lever C to turn the motor off.

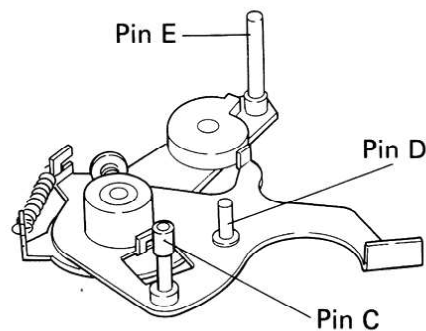

Fig. 8-12

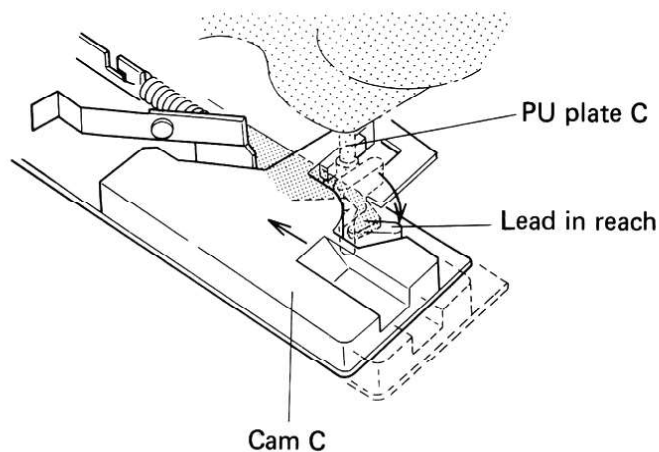

Fig. 8-13

• REPEAT OPERATION

When the repeat button is pressed during record play, the control base unit will be as shown in Fig. 9-2. Lever D will thus not move any further left than a pre-determined position.

After the end of the "lead-in" operation, the "auto-return" operation commences when the end of record play is reached.

1. At the start of the auto-return operation, cam A rotates to move plate A towards the right.
2. Cam C pushes against cam D to raise the arm elevation.
3. Cam C pushes pin C of the PU plate to the right.
4. When cam C reaches across to the right hand side, the lead-in latch grasps pin C of the PU plate, resulting in the tonearm being moved across to the disc.

The main difference here to the auto-lead-in operation is that pin A of lever C pushes plate D when the repeat button is pressed, resulting in the lead-in latch not being opened by plate D (as occurs during auto-return). Consequently, the tonearm does not stay at the arm rest, but proceeds to move back towards the record for repeated play. Subsequent operations are the same as during normal autolead-in operation.

• INTERRUPTION OF RECORD PLAY

1. Press the START/STOP button.
2. Pin A of lever D pushes plate C to the right, resulting in the plate C plate spring forcing lever A upwards. And this in turn repels the detector assembly.
3. Subsequent steps are the same as steps 3 to 10 described under auto-return.

• MANUAL START AND STOP

1. When the tonearm is lifted over to the disc by hand, pin E of the PU plate rotates lever B in the clockwise direction. Lever B is thereby disengaged from lever C, switching the micro-switch on to start the motor.
2. When the tonearm is lifted off the record during play and returned to the arm rest, pin E of the PU plate rotates lever B in the clockwise direction and this lever thus presses against lever C. When lever C then makes contact with the microswitch (pressing the microswitch push-button), the motor is subsequently turned off.

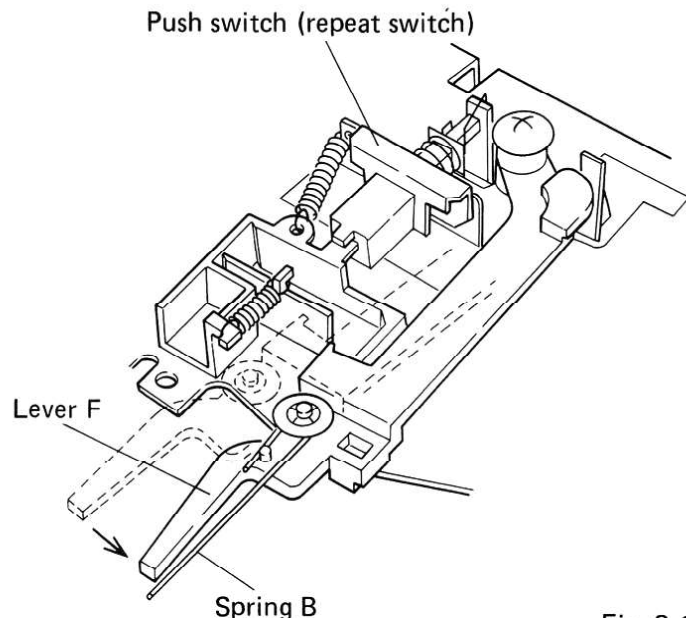

Fig. 8-14

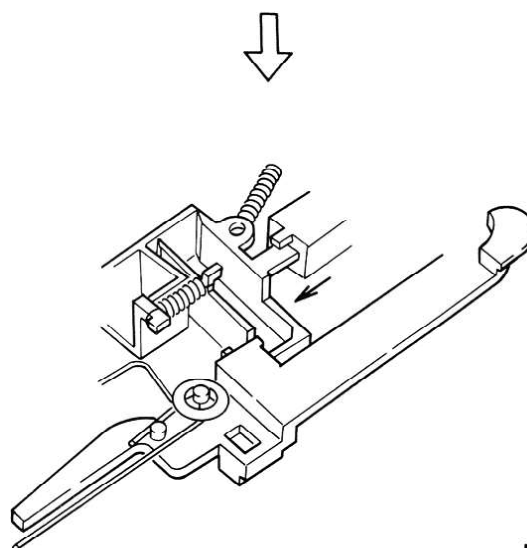

Fig. 8-15

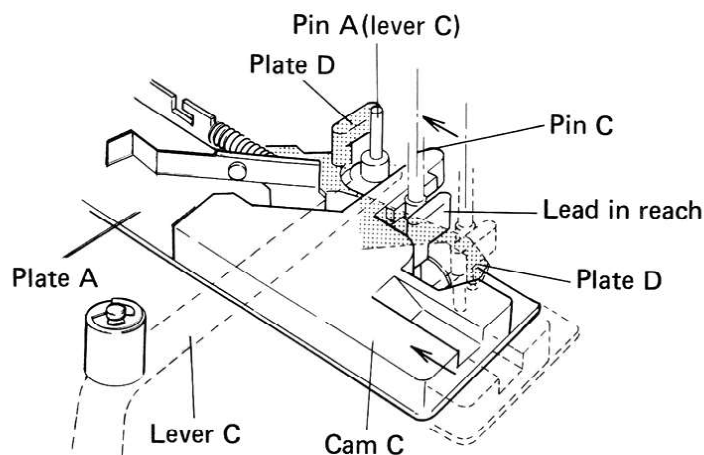

Fig. 8-16

9. ADJUSTMENT

9.1 STYLUS DESCENT POSITION

If the stylus does not descend onto the lead-in groove on the record during automatic play, adjust as follows:

1. Place a 30cm (12-inch) LP record on the platter.
2. Go through the operation for automatic play once and check the level and direction of the stylus' deviation from the norm.
3. Return the tonearm to the arm rest with one hand, and then adjust the stylus descent-position by turning the adjusting screw in the adjusting hole using the screwdriver.
 - When the stylus descends outside the lead-in groove, turn the adjusting screw clockwise.
 - When the stylus descends inside the lead-in groove, turn the adjusting screw counter-clockwise.
 - Each half-turn of the adjusting screw moves the starting point about 6mm.

NOTE:

Be very careful not to damage the record and the stylus when you are adjusting the position of the stylus descent.

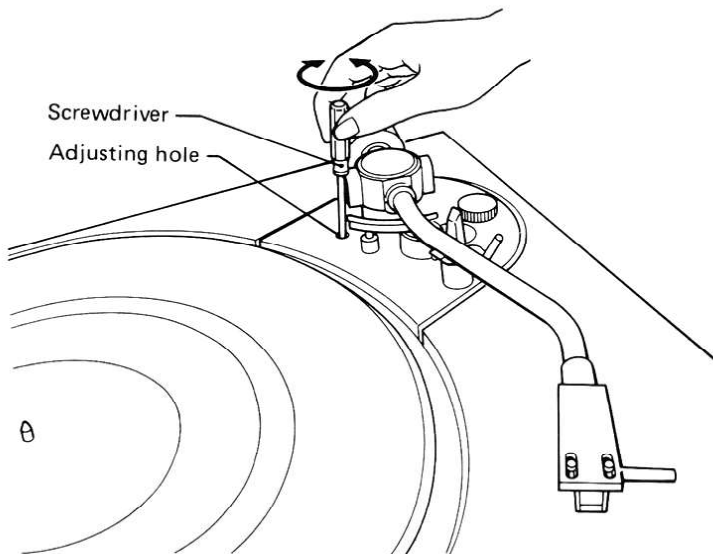

Stylus descends outside the groove

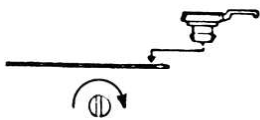

Stylus descends inside the groove

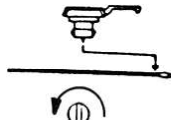

Fig. 9-1

9.2 AUTO RETURN ADJUSTMENT

1. Turn the auto return adjustment screw full around clockwise.
2. Move the tonearm right across towards the center.
3. When the auto return adjustment screw is turned back a little at a time counter clockwise, the tonearm will commence to return to the outer circumference.
4. Stop turning the adjustment screw once the stylus tip is 00mm away from the center shaft.
5. Once the above adjustment procedure has been completed check that the tonearm returns automatically as designed.

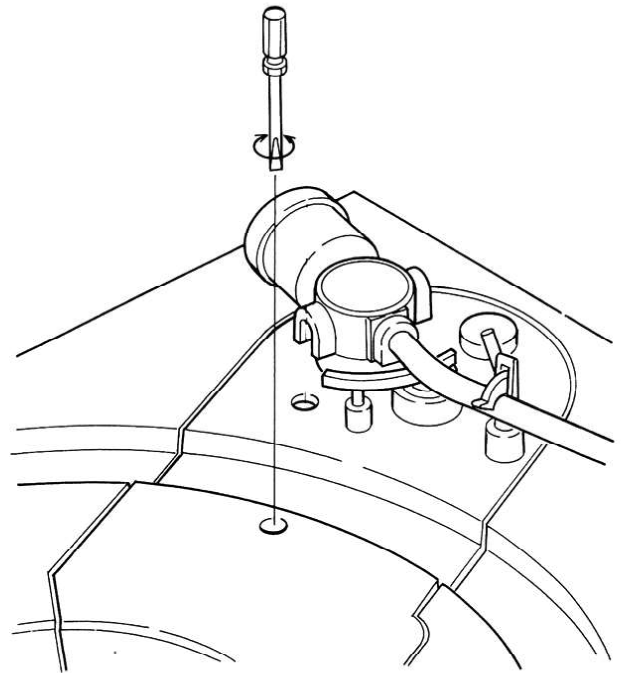

Fig. 9-2

9.3 D.D. MOTOR ADJUSTMENT (PL-300 AND PL-400)

1. Connect the TP3 and TP4 terminals of the control assembly to the inputs (CH1 and CH2) of a dual trace oscilloscope.
2. Turn the power on and start the turntable platter rotating.
3. Adjust VR1 and VR2 of the control assembly so that the rising edge of the waveform on TP3 lies inside the square waveform on TP4 as shown in Fig. 9-4.
4. This adjustment is performed from the direction of the turntable base plate as shown in Fig. 9-3.
5. Adjust VR1 for 33rpm speed, and VR2 for 45rpm.

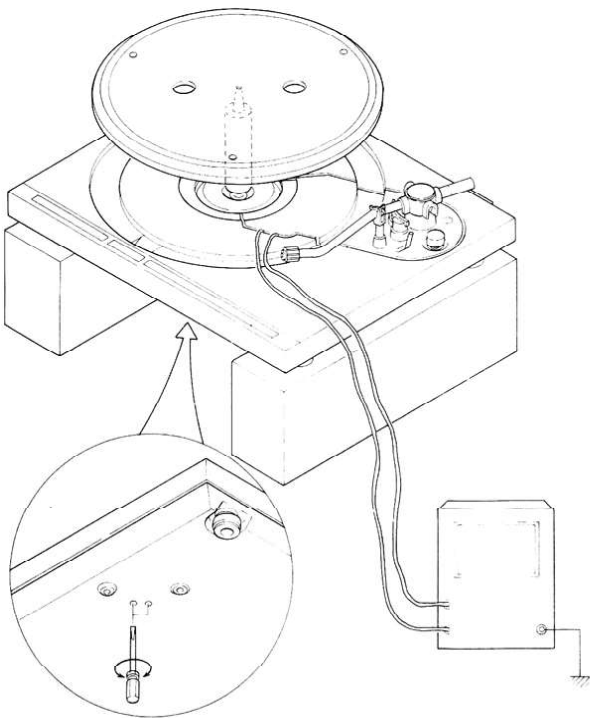

Fig. 9-3

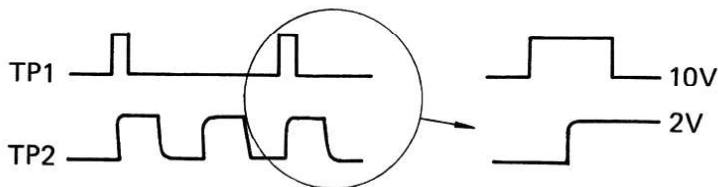

Fig. 9-4

9.4 D.D. MOTOR ADJUSTMENT (PL-200 AND PL-255)

1. Turn the power on and start the turntable platter rotating.
2. Turn the speed adjustment knob around to the mechanically center position.
3. Adjust VR1 and VR2 in the control assembly so that the stroboscope appears to be stationary. Again this adjustment is performed from below.
4. Adjust VR1 for 33rpm speed, and VR2 for 45rpm.
5. As can be seen in Fig. 1, the rotor magnet generates an 8 polar trapezoidal magnetic wave, and by phase additions of the coil switching waveforms a even torque is obtained.

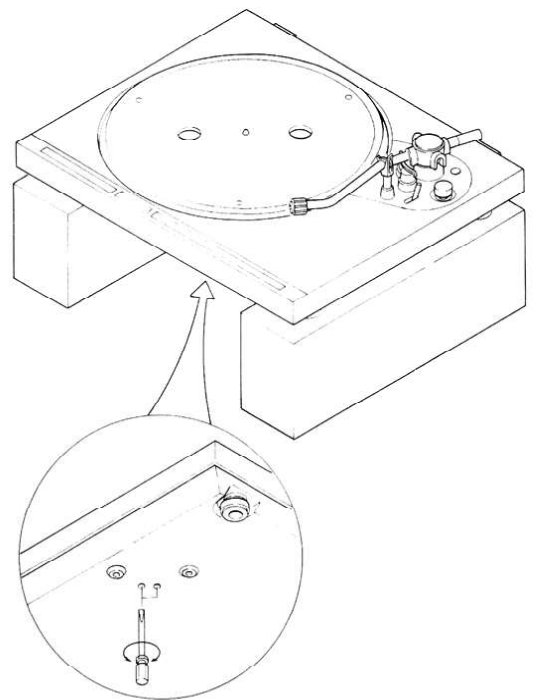

Fig. 9-5