

Service Manual

PIONEER

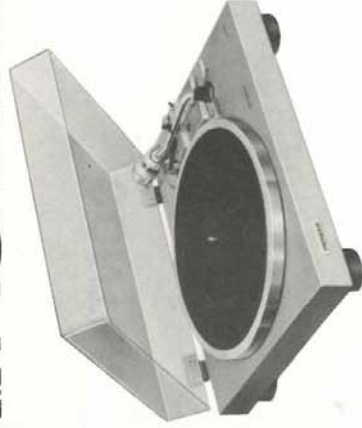

STEREO TURNTABLE

PL-514

Q, KCT, KUT

PL-514A

HP, Q

MODEL PL-514 AND PL-514A COME IN FOUR VERSIONS DISTINGUISHED AS FOLLOWS.

Type	Voltage	Remarks
Q	120V and 240V (Switchable)	General export model
KCT	120V only	Canada model (without cartridge)
KUT	120V only	U.S.A. model (without cartridge)
HP	220V~240V	Europe or Oceania model

Both models PL-514 and PL-514A have the same basic mechanism and performance. The only difference is the wooden cabinet finish.

CONTENTS

1. SPECIFICATIONS	3
2. PANEL FACILITIES AND OPERATION	4
3. PART LOCATION	5
4. MECHANISM OPERATION AND ADJUSTMENT	
4.1 Start of Performance	6
4.2 Auto-return Detection	6
4.3 Auto-return Operation	7
4.4 Adjustment	7
5. HP TYPE EXPLODED VIEWS	
5.1 Cabinet	9
5.2 Tonearm	10
5.3 Mechanism Parts	11
5.4 Packing Case	12
6. Q TYPE EXPLODED VIEWS	
6.1 Cabinet	13
6.2 Tonearm	14
6.3 Mechanism Parts	15
6.4 Packing Case	16
7. KCT, KUT TYPE EXPLODED VIEWS	
7.1 Cabinet	17
7.2 Tonearm	18
7.3 Mechanism Parts	19
7.4 Packing Case	20

1. SPECIFICATIONS

Motor and Turntable

Drive System: Belt-drive
 Motor: 4-pole synchronous
 Turntable Platter: 320mm diam. aluminum alloy die-cast
 Speeds: 33-1/3 and 45 rpm
 Wow and Flutter: Less than 0.055% (WRMS)
 Signal-to-Noise Ratio: More than 65dB (DIN-B)

Tonearm

Type: Static-balance type, S-shaped pipe arm
 Effective Arm Length: 221mm
 Overhang: 15.5mm
 Tracking Error: 0.525 deg./in, 0.21 deg./cm
 Usable Cartridge Weight: 4g (min.) to 10g (max.)

Other Features

Anti-skating force control, Cueing device, Detachable dust cover, Insulator feet, Plug-in type headshell,

Miscellaneous

Power Requirements:
 PL-514/Q, QT AC110V-130V/220V-240V 50/50Hz
 PL-514A/Q AC120V, 60Hz
 PL-514/KCT, KUT 220V-240V 50Hz
 PL-514A/HP 10W
 Power Consumption: 440(W) x 140(D) x 365(H) mm
 Dimensions: 17-5/16(W) x 5-1/2(D) x 14-3/8(H) in
 Weight: 7.5kg/16lb 8oz

PC-110/II Specifications (PL-514, PL-514A Q type only)

Type: Moving magnet type
 Stylus: 0.5mil diamond(PN-110/II)
 Output voltage: 3.5mV (1kHz, 50mm/s RMS)
 Tracking Force: 1.5g to 2.5g (proper 2.2g)
 Frequency Response: 15 to 25,000Hz

Accessories

EP adaptor 1
 Screwdriver 1
 Cartridge mounting screws PL-514 { 6
 Cartridge mounting nuts KCT, KUT { 2
 Cartridge mounting washers only } 2
 Operating instructions 1

NOTES:

- Specifications and design subject to possible modification without notice, due to improvements.
- The PL-514/Q, PL-514A/HP, Q (with the accessory PC-110/II cartridge) do not come with cartridge mounting screws, nuts or washers.

HP only

For Use in United Kingdom and Australia

Please note:

Models employ 3-conductor mains leads. Please read the following instructions carefully before connecting.

WARNING: THIS APPARATUS MUST BE EARTHED.

CAUTION 240V: MAINS SUPPLY VOLTAGE IS FACTORY ADJUSTED AT 240 VOLTS.

IMPORTANT

The wires in this mains lead are coloured in accordance with following code:

Green-and-yellow: Earth
 Blue: Neutral
 Brown: Live

As the colours of the wires in the mains lead of this apparatus may not correspond with the coloured markings identifying the terminals in your plug, proceed as follows.

The wire which is coloured green-and-yellow must be connected to the terminal in the plug which is marked by the letter E or by the safety earth symbol \equiv or coloured green or green-and-yellow.

The wire which is coloured blue must be connected to the terminal which is marked with the letter N or coloured blue or black.

The wire which is coloured brown must be connected to the terminal which is marked with the letter L or coloured brown or red.

The power cord should be connected last, make sure that the Power switch is OFF.

First insert the female appliance connector of the mains cord into the AC inlet, then plug the cord to the wall socket.

Be sure the appliance connector is fully inserted into the AC inlet.

Unplug the set from the wall socket when it is not to be used for an extended period of time.

FOR YOUR SAFETY

1. Insert this plug only into effectively earthed three-pin plug-socket outlet.
2. If any doubt exists regarding the earthing, consult a qualified electrician.
3. Extension cords, if used, must be three-core correctly wired.

2. PANEL FACILITIES AND OPERATION

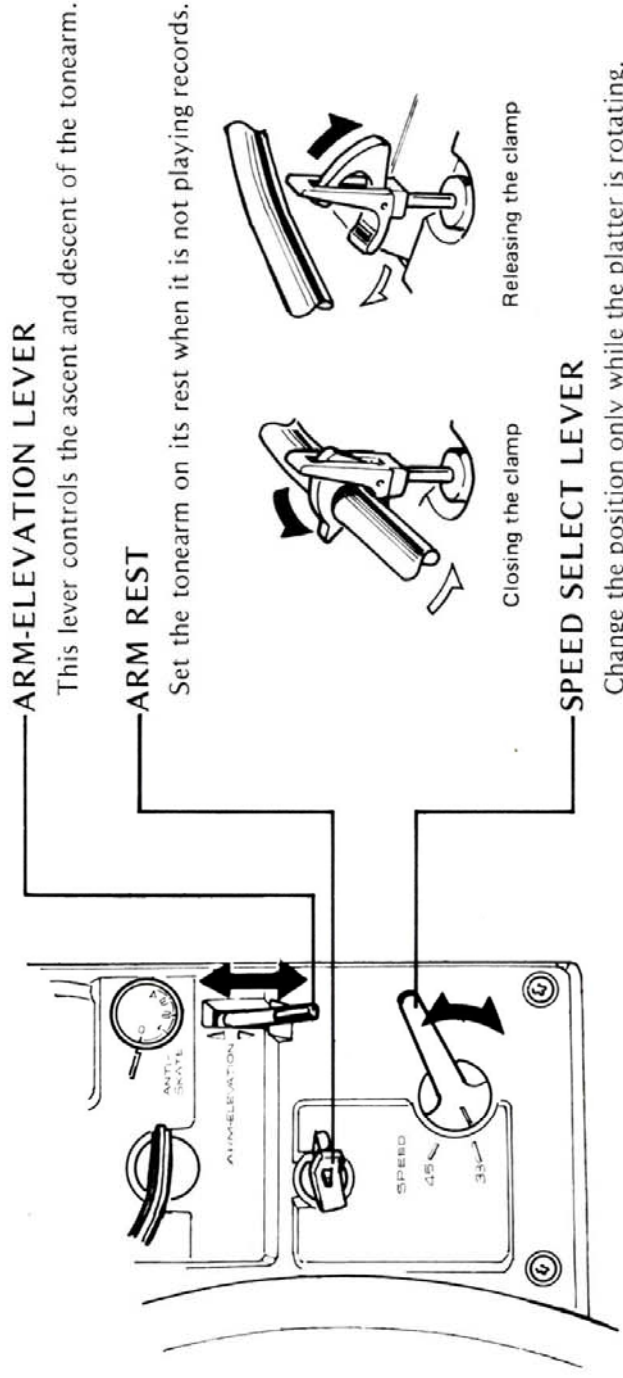

OPERATING PROCEDURES

1. Place the record to be played on the platter.
2. Set the ARM-ELEVATION lever to the ▲ position.
3. Remove the stylus cover and release the arm clamp.
4. Hold the headshell by the finger lift and move the stylus over the record to the track you want played. The platter will begin to rotate.
5. Set the SPEED select lever to the speed at which the record is to be played.
6. Set the ARM-ELEVATION lever to the ▼ position. The stylus will descend slowly to the record and play will begin.
7. Adjust the volume and tone controls on the amplifier to the preferred levels, and then sit back and enjoy your record.
8. After the record has been played, the automatic return mechanism is actuated and the tonearm returns to the arm rest. At the same time, the power to the turntable is turned off, and the platter stops rotating.
9. Secure the tonearm to the arm rest with the clamp and attach the stylus cover to protect the stylus.

OPERATION PRECAUTIONS

- Always clean the stylus both before and after playing a record with a soft brush and try to make it a rule to clean the records with a good quality cleaner.
- Be careful not to make the turntable vibrate while a record is playing since this can result in damage to the stylus and record.
- When changing over the headshell, clamp the tonearm to the arm rest so that the tonearm shaft is not strained in any way.
- Place only one record at a time on the platter.
- If two or more records are stacked on the platter, the stylus will not make proper contact with the grooves, and this will impair the quality of reproduction.
- Do not disconnect the power cord while the stylus is still in a record groove as this may result in damage to the stylus and record.
- Do not force the tonearm closer than 40mm to the center shaft or outwards from the arm rest. If this distance is exceeded, you may damage the internal mechanisms and render automatic operation ineffective.

This lever controls the ascent and descent of the tonearm.

ARM REST

Set the tonearm on its rest when it is not playing records.

Closing the clamp

Releasing the clamp

SPEED SELECT LEVER

Change the position only while the platter is rotating.

3. PART LOCATION (KCT type)

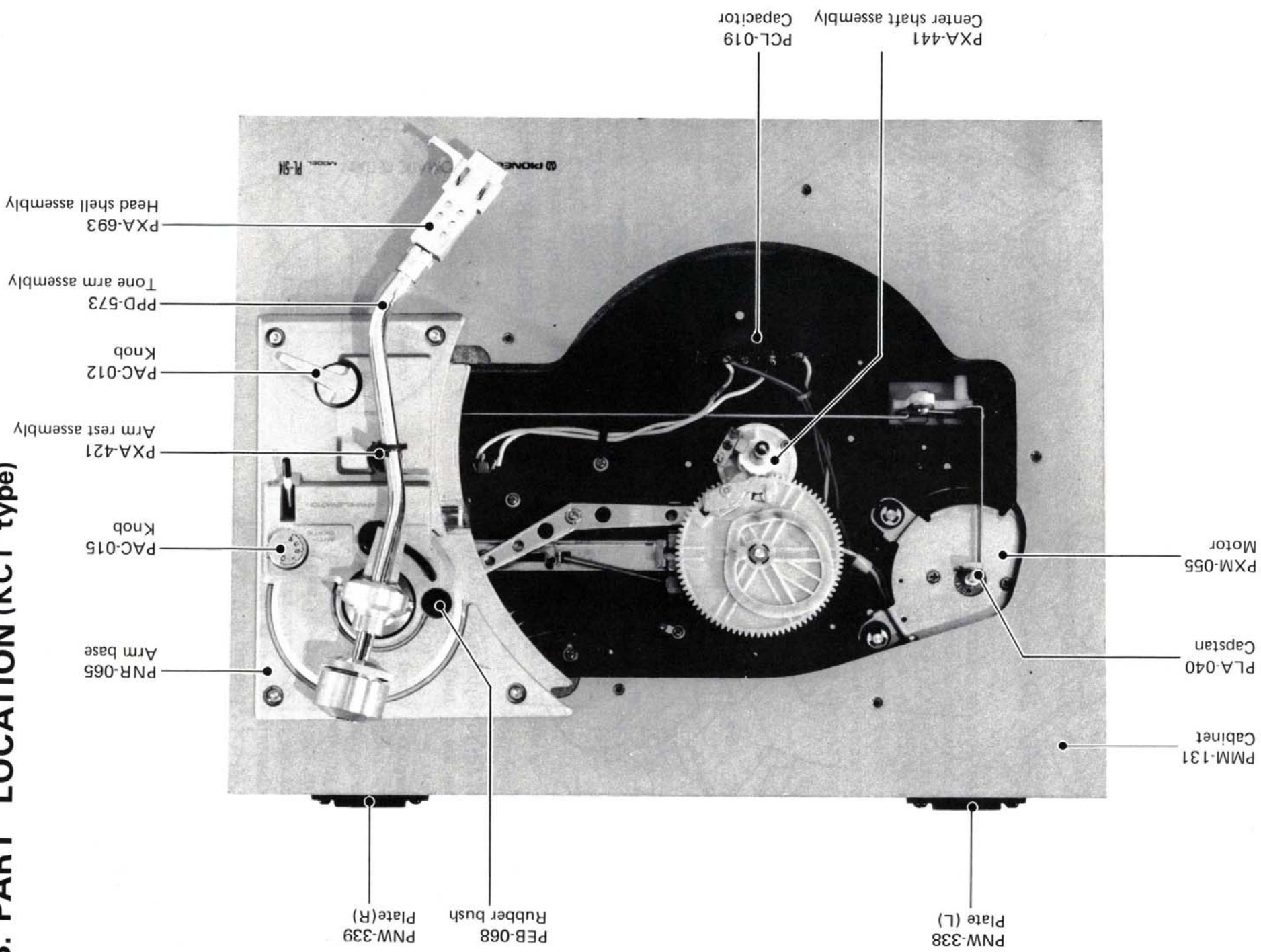

4. MECHANISM OPERATION AND ADJUSTMENT

4.1 START OF PERFORMANCE

1. The tonearm is moved from the arm rest to above the turntable.
2. Lever A, connected to the tonearm, unlocks lever B, and the microswitch is turned ON (Fig. 1).
3. When the microswitch is turned ON, the motor is started and the turntable begins to rotate.

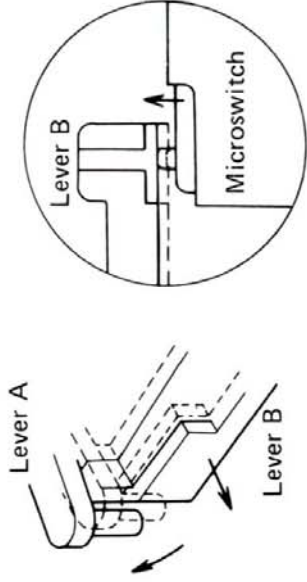

Fig. 1

4.2 AUTO-RETURN DETECTION

1. When the stylus nears the center shaft, lever A contacts lever C (Fig. 2).

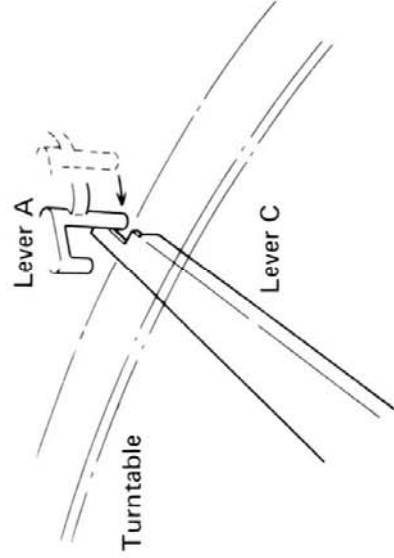

Fig. 2

2. Lever C pushes plate A by an amount directly proportional to the amount of movement of the tonearm (Fig. 3).

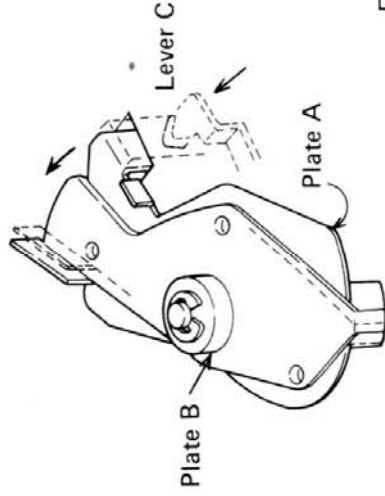

Fig. 3

3. Plate B atop plate A is moved toward gear A by the movement of plate A.
4. The front end of plate B moves approximately 0.1mm when the stylus is advanced 1mm toward the center shaft by one revolution of the record.
5. The tooth of gear A has the dimensional difference shown in Fig. 4-a.
6. Plate B is pushed back by this dimensional difference at a stylus movement of within 1mm per revolution of the record.
7. When the stylus enters the lead-out groove in the record at the end of the performance, it is moved 4mm toward the center shaft by one revolution of the record.
8. The end of plate B contacts the tooth of gear A (Fig. 4-b).
9. Gear A and gear B are engaged, and gear B is turned by rotation of the turntable.

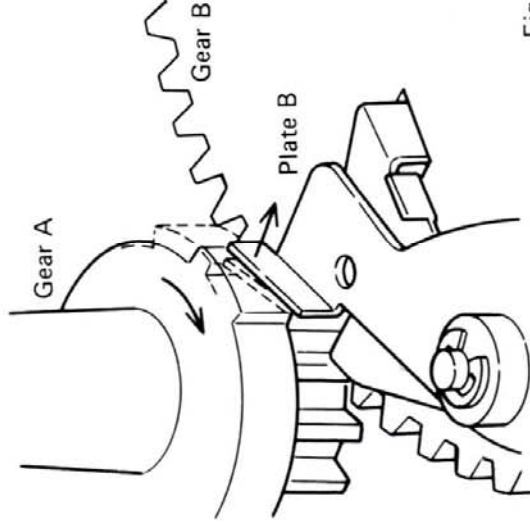

Fig. 4-a

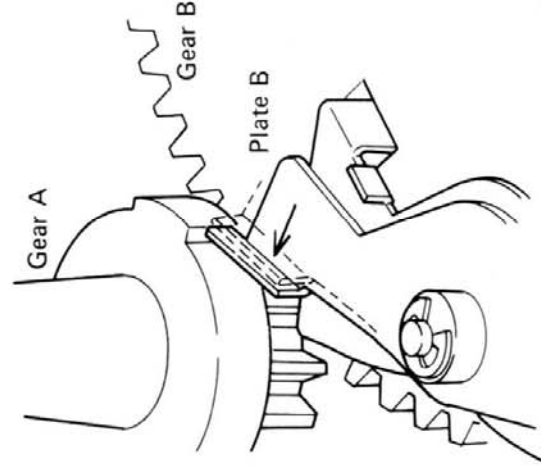

Fig. 4-b

4.3 AUTO-RETURN OPERATION

1. Gear B is rotated by detection of auto-return.
2. Lever D moves along the groove of gear B, and the tone arm is lifted (Fig. 5).

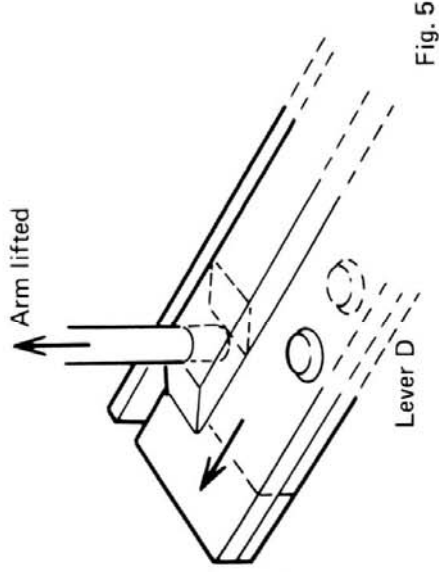

Fig. 5

3. Lever A is pushed and the tonearm is returned to the arm rest by lever D (Fig. 6).

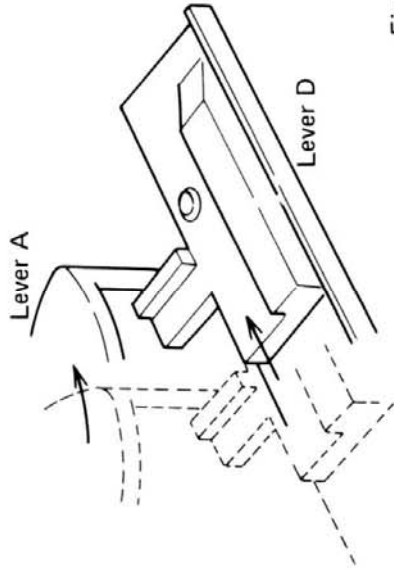

Fig. 6

4. When gear B has rotated one revolution, lever D is returned to its original position.
5. When lever D has returned to its original position, lever B is pushed by lever A and the microswitch is turned OFF (Fig. 7).
6. When the microswitch is turned OFF, the motor is stopped, and the turntable also stops.

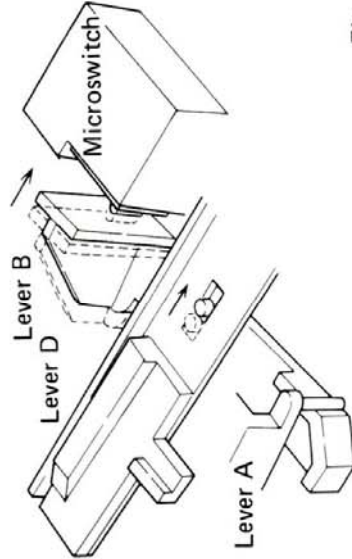

Fig. 7

4.4 ADJUSTMENT

4.4.1 Auto-return Detection Position

1. Plate B contacts the tooth of gear A, the turntable is rotated, and the auto-return detector is reset.

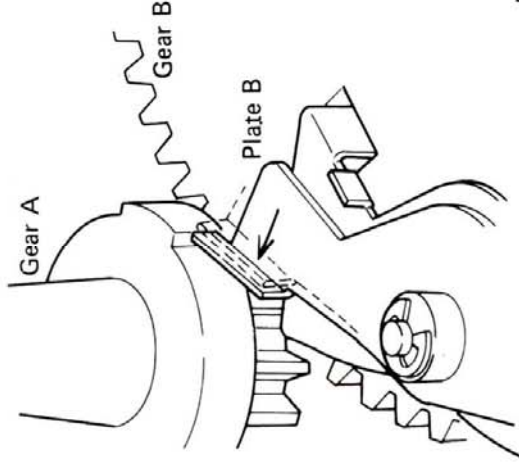

Fig. 8

2. Adjust the adjusting screw so that plate B contacts the tooth of gear A when the stylus has reached a point 62mm from the center shaft.

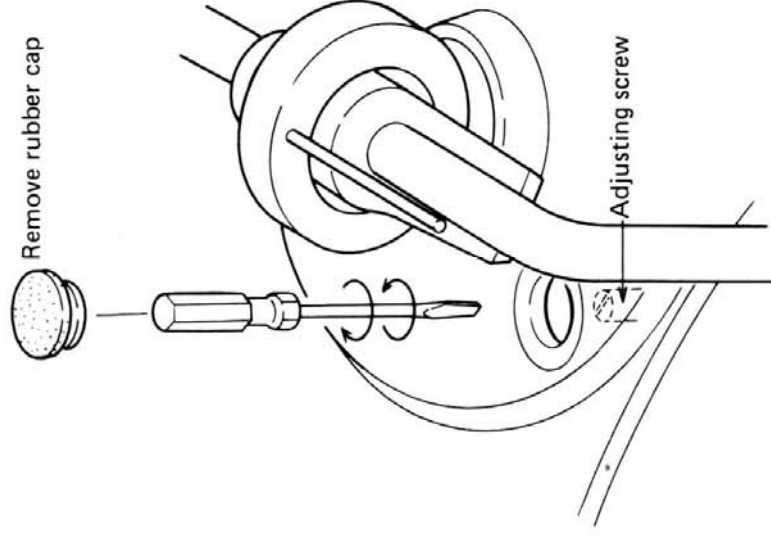

Fig. 9

4.4.2 Microswitch ON Timing

1. Adjust at the adjusting point shown in Fig. 10-b so that lever A and lever B become as shown in Fig. 10-a when the tonearm is fastened to the arm rest.
2. Adjust the adjusting screw (Fig. 10-c) so that lever B and the microswitch are positioned as shown in Fig. 10-c when the tonearm is fastened to the arm rest.
3. Since this adjustment will adversely effect the auto-return detection position, the auto-return detection position must be readjusted.

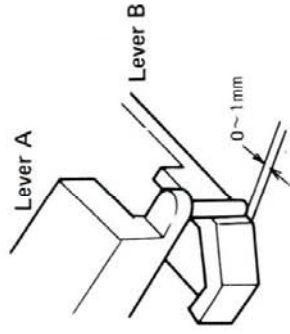

Fig. 10-a

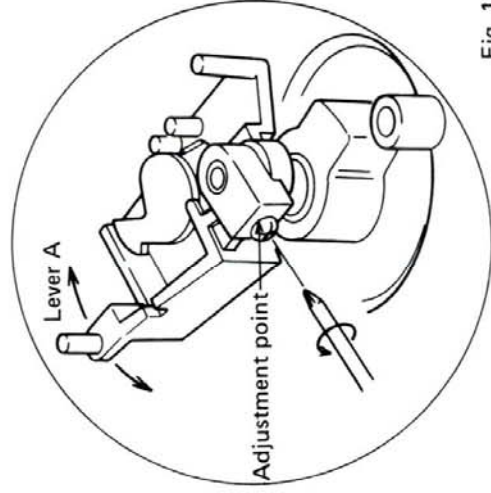

Fig. 10-b

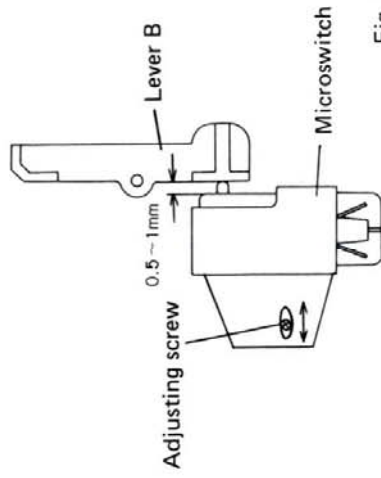
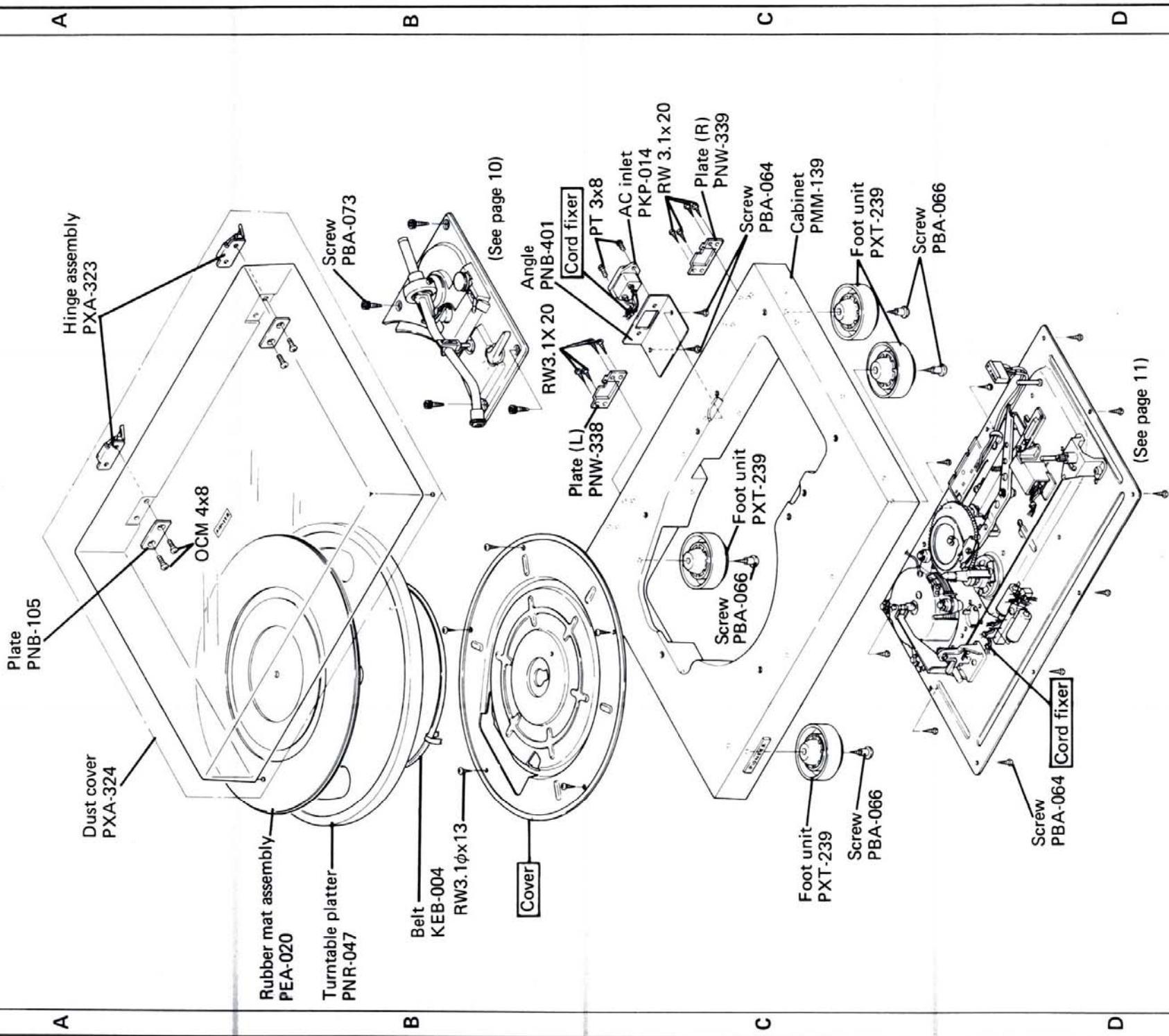

Fig. 10-c

5. HP type EXPLODED VIEWS

5.1 CABINET

NOTE:
Parts indicated in mark cannot be supplied.



5.2 TONEARM

NOTE:

Parts indicated in mark cannot be supplied.

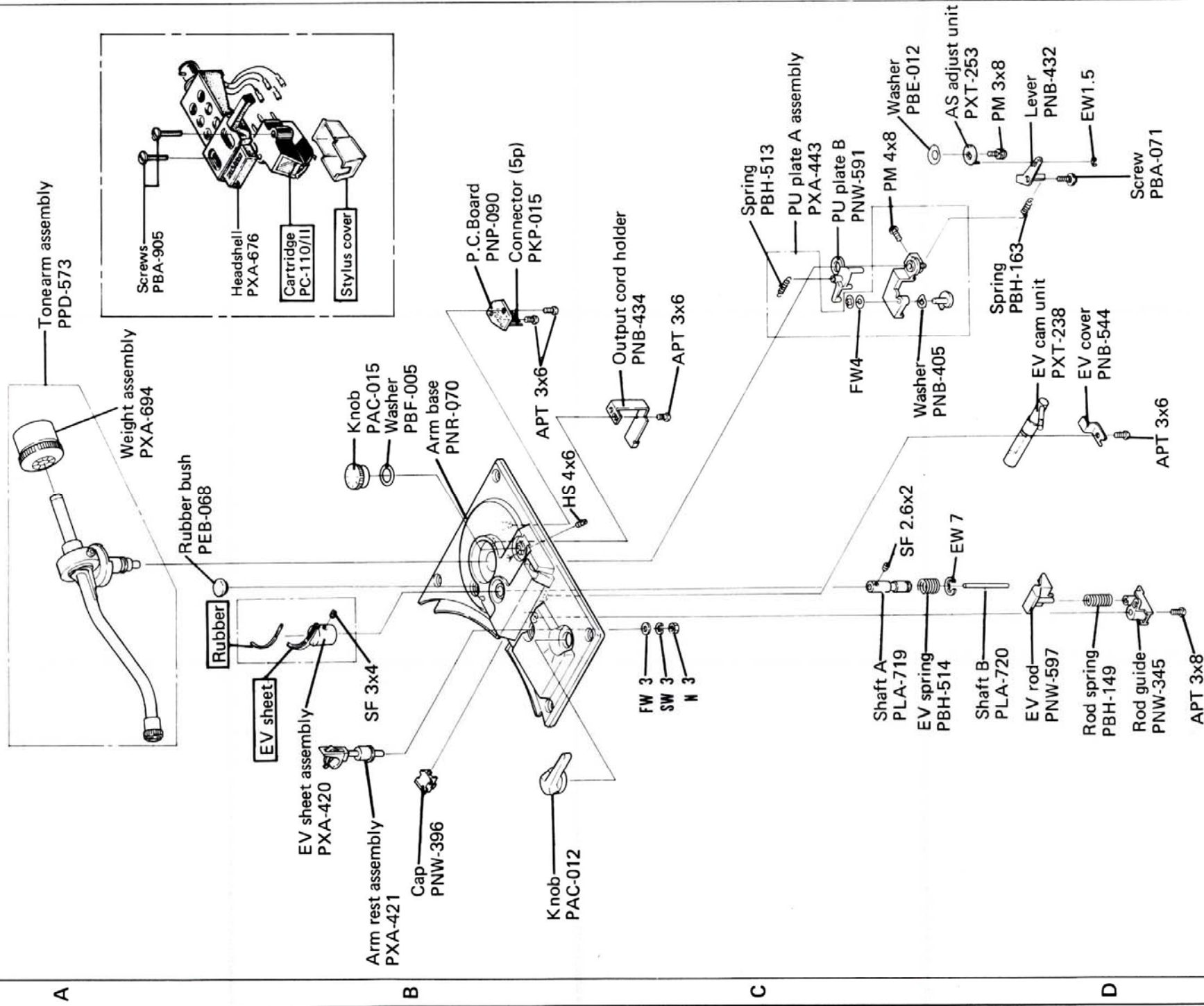

5.4 PACKING CASE

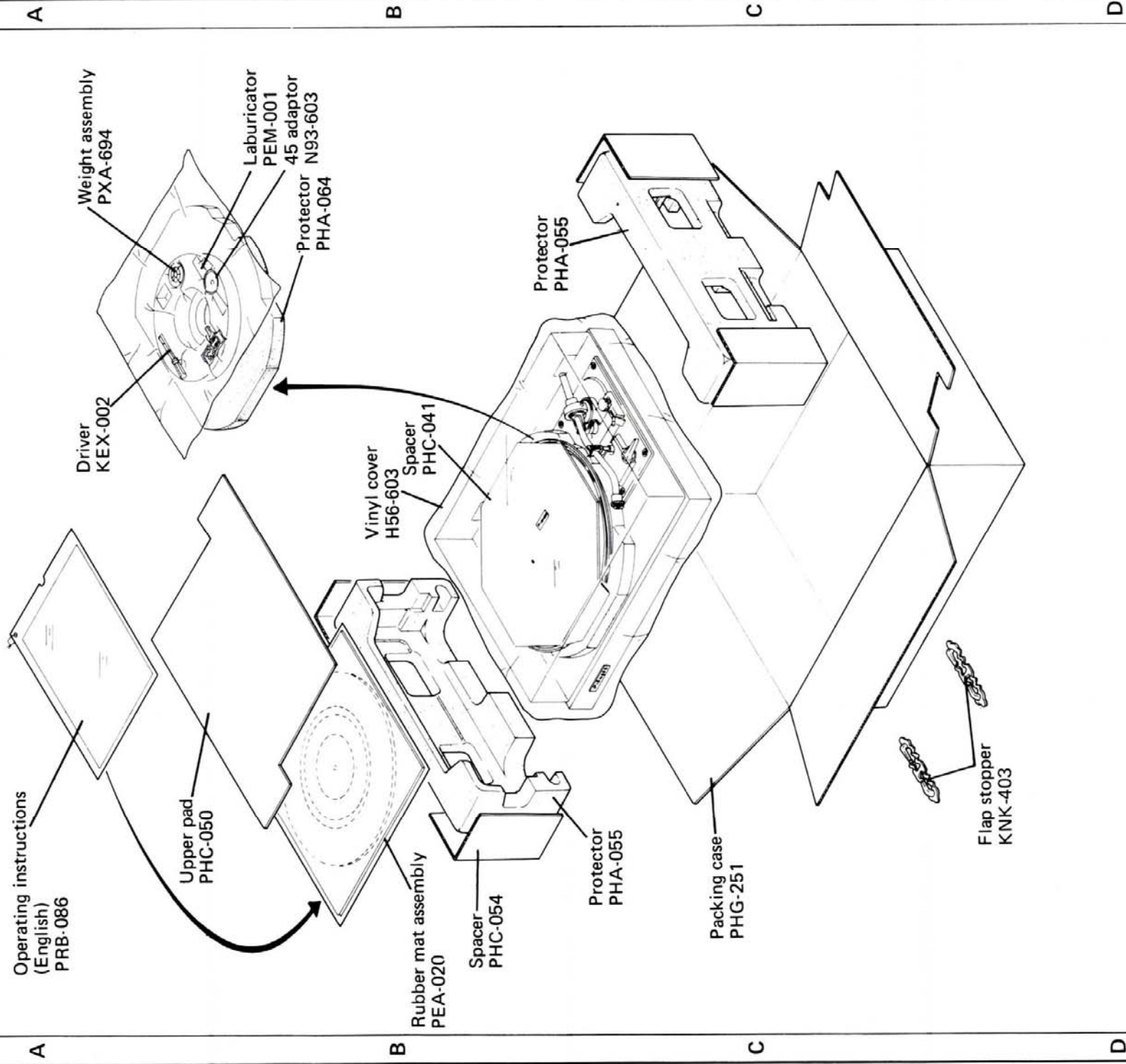

6. Q type EXPLODED VIEWS

6.1 CABINET

NOTE:

Parts indicated in mark cannot be supplied.

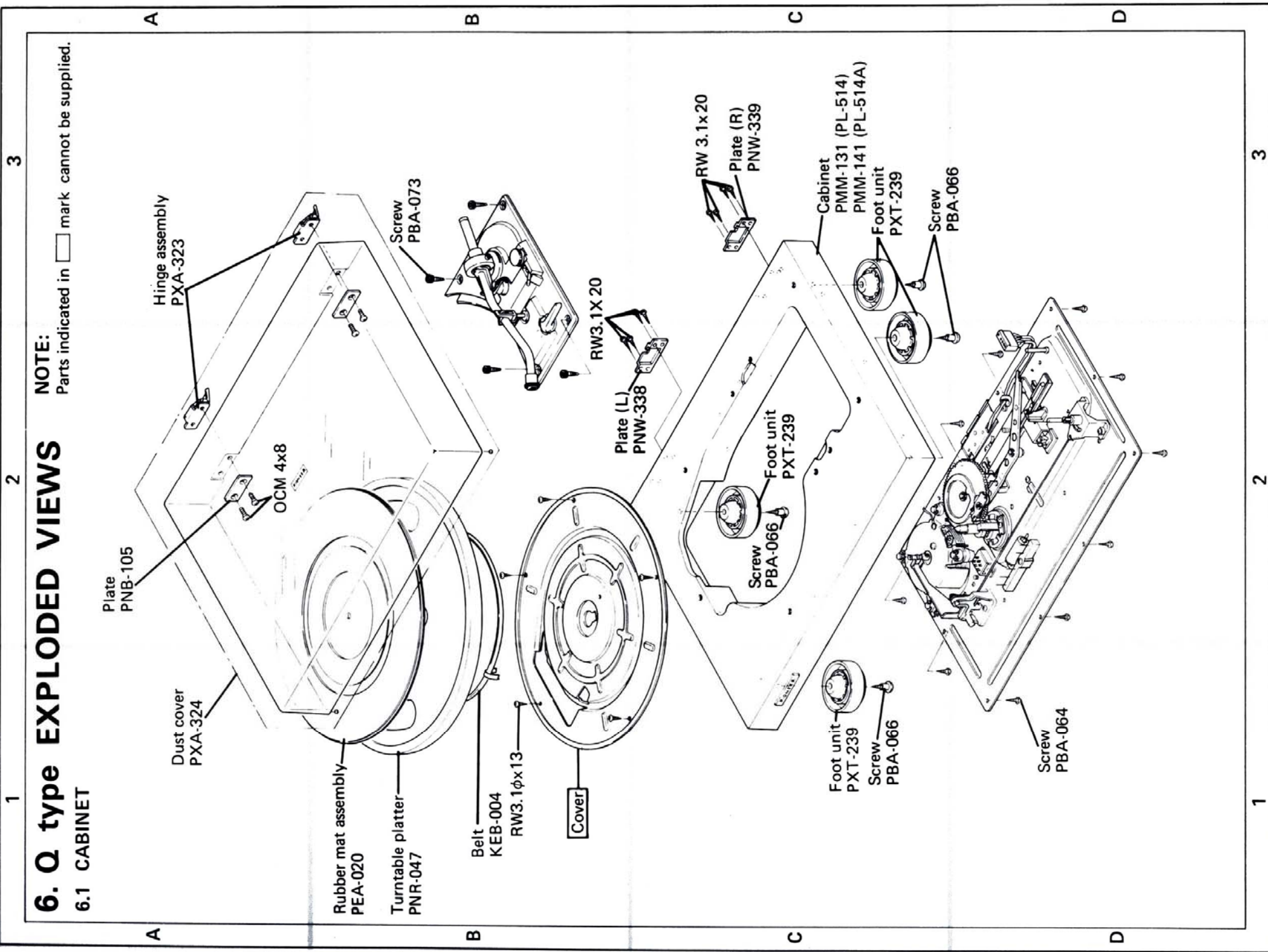

6.2 TONEARM

NOTE:

Parts indicated in mark cannot be supplied.

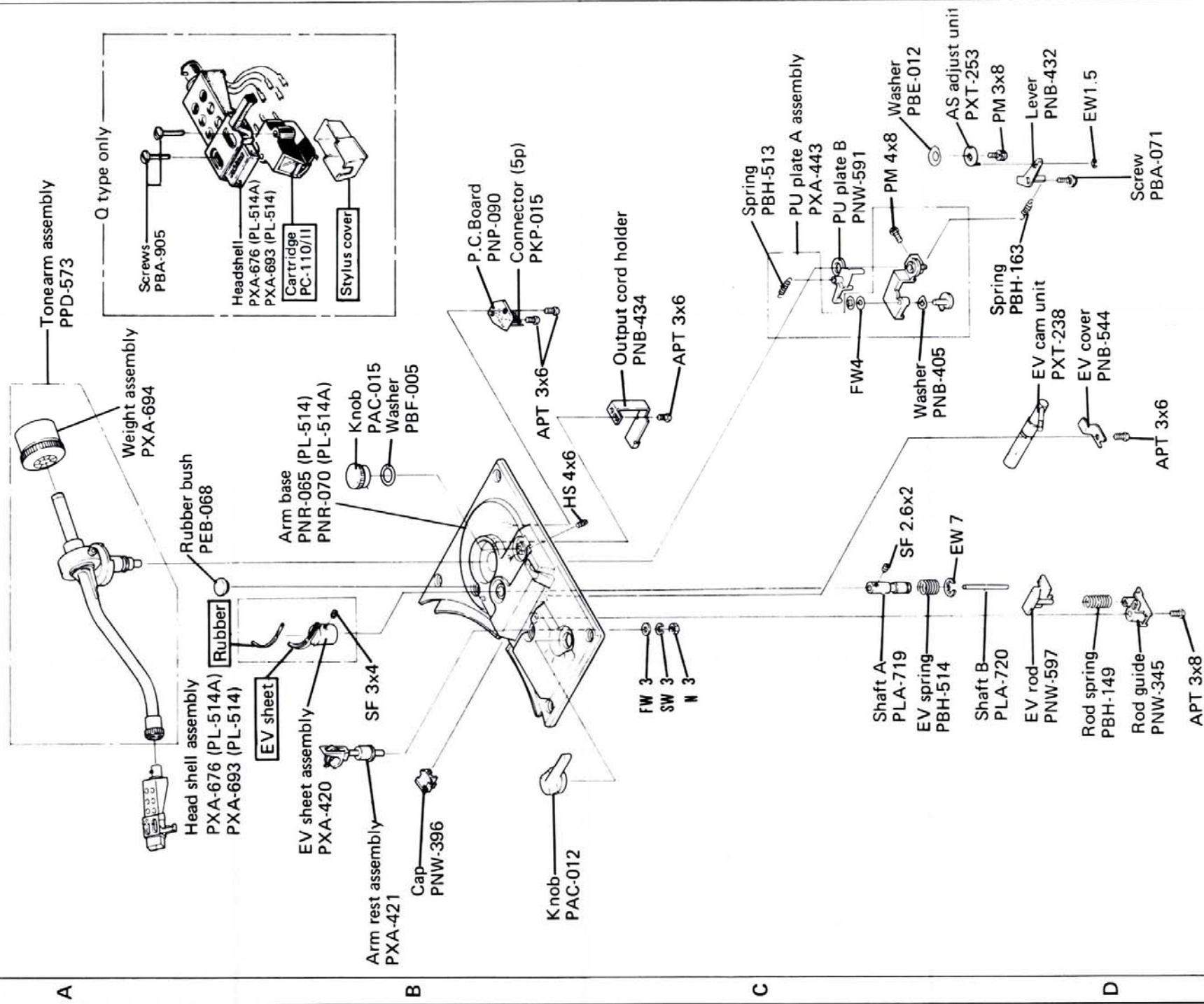

6.4 PACKING CASE

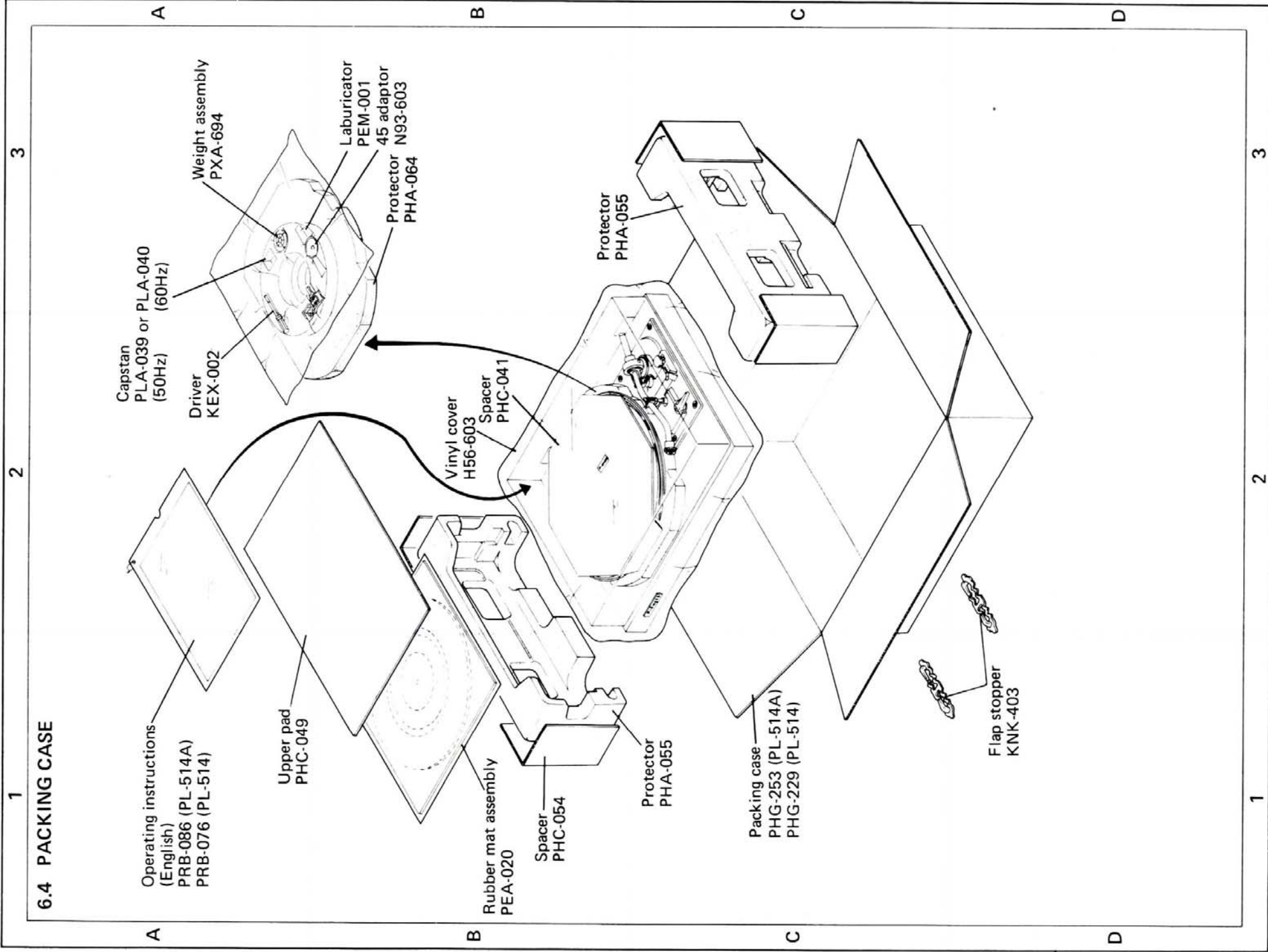

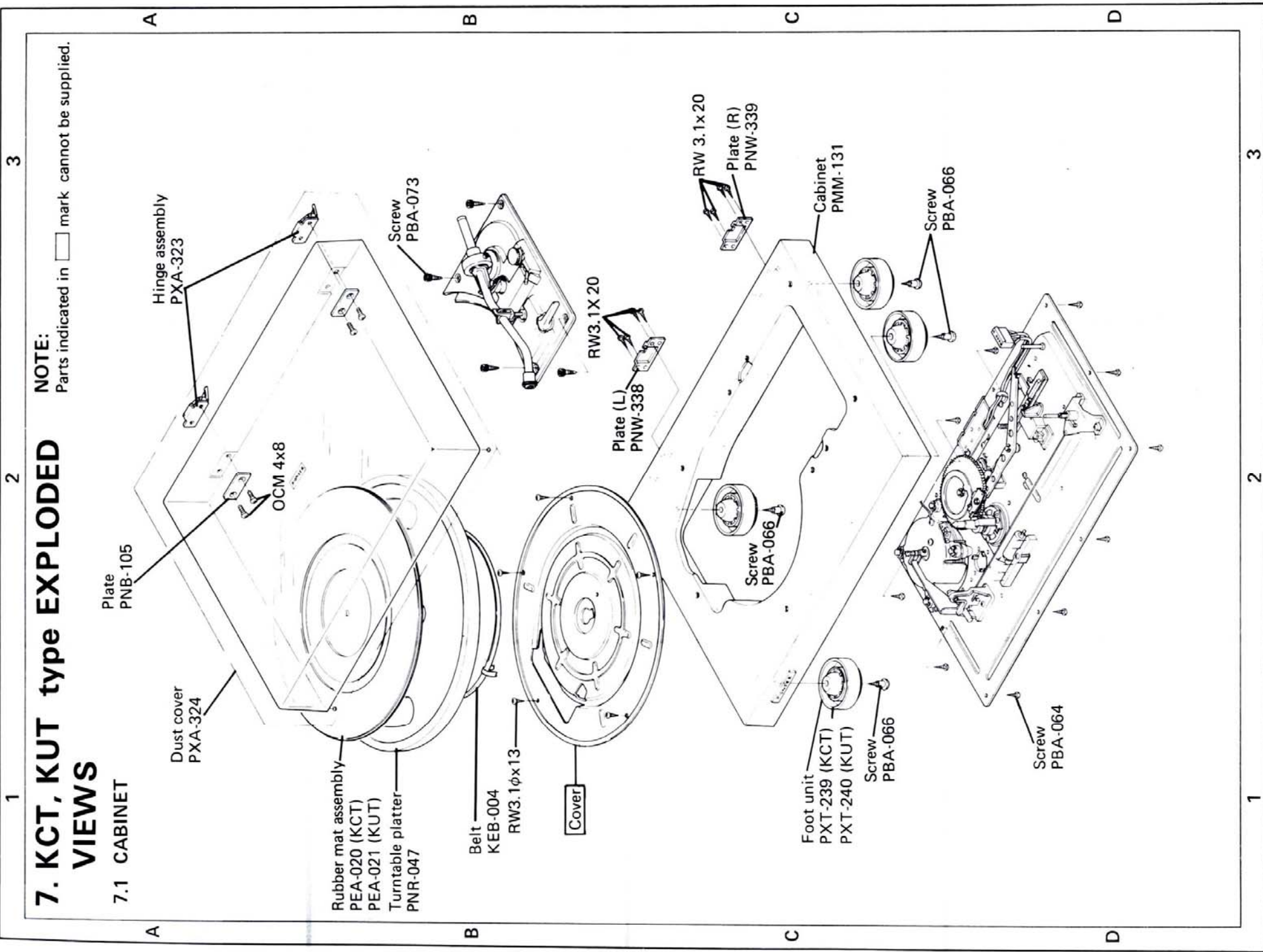

7.2 TONEARM

NOTE:

Parts indicated in mark cannot be supplied.

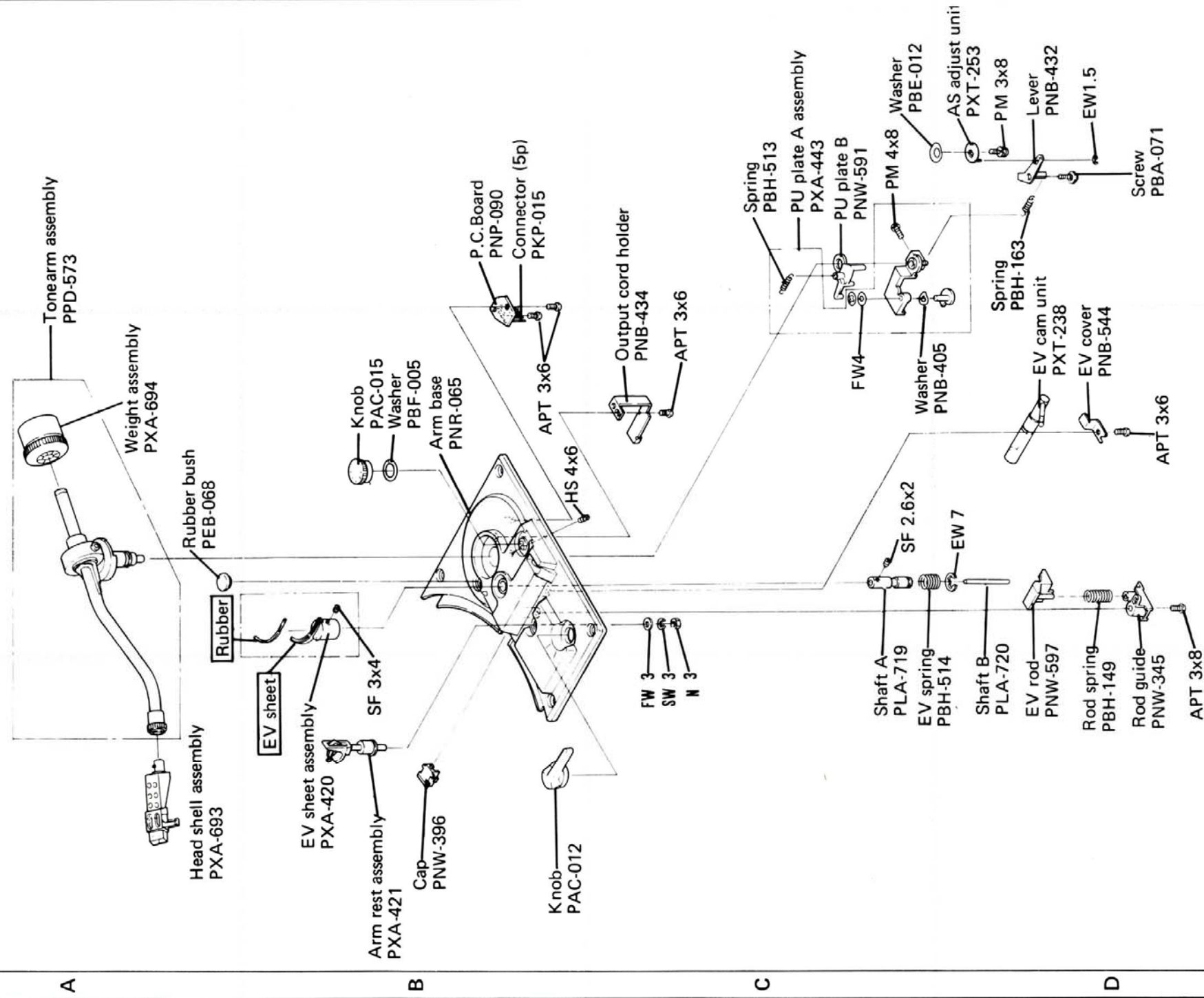

7.3 MECHANISM PARTS

NOTE:



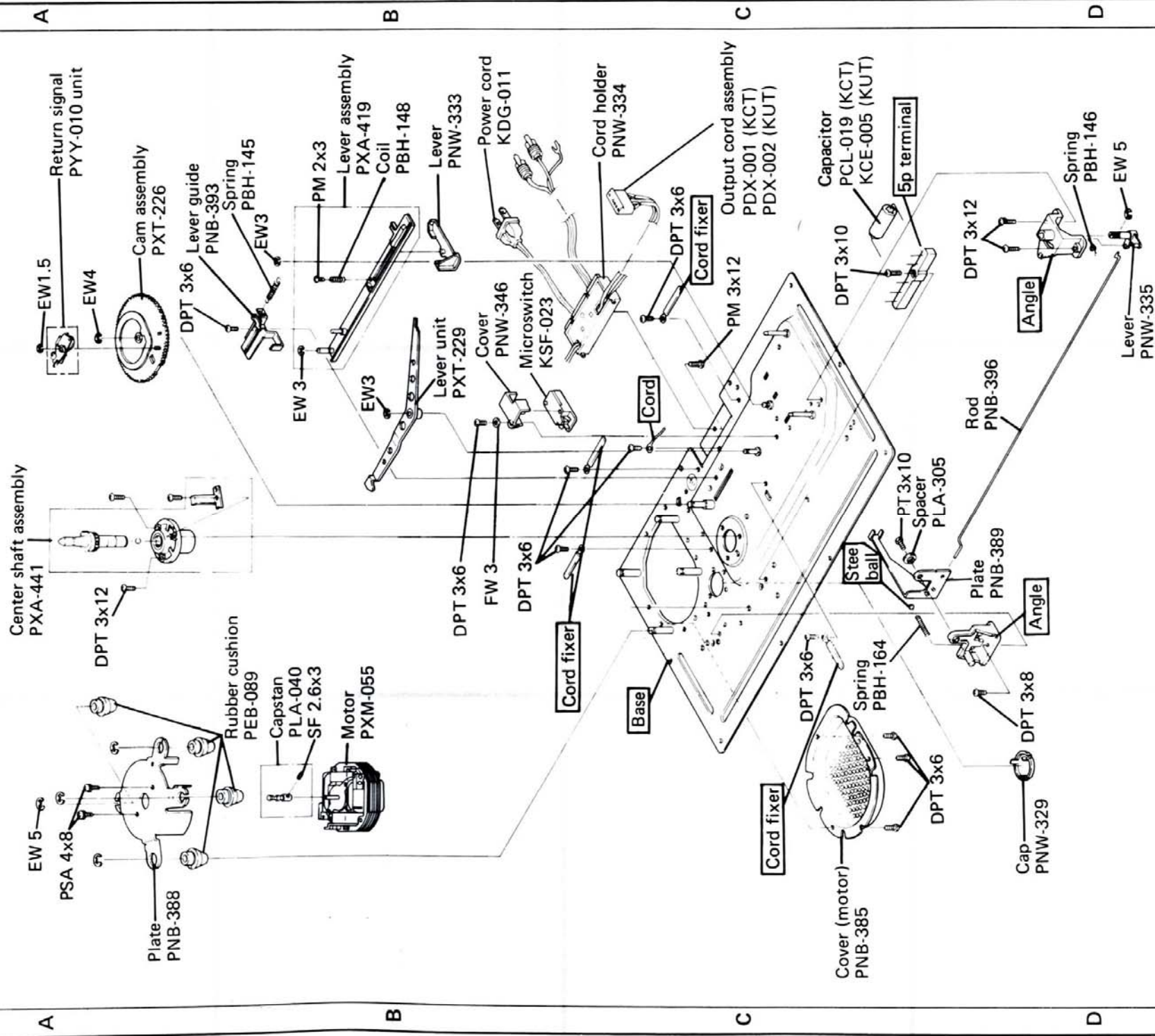

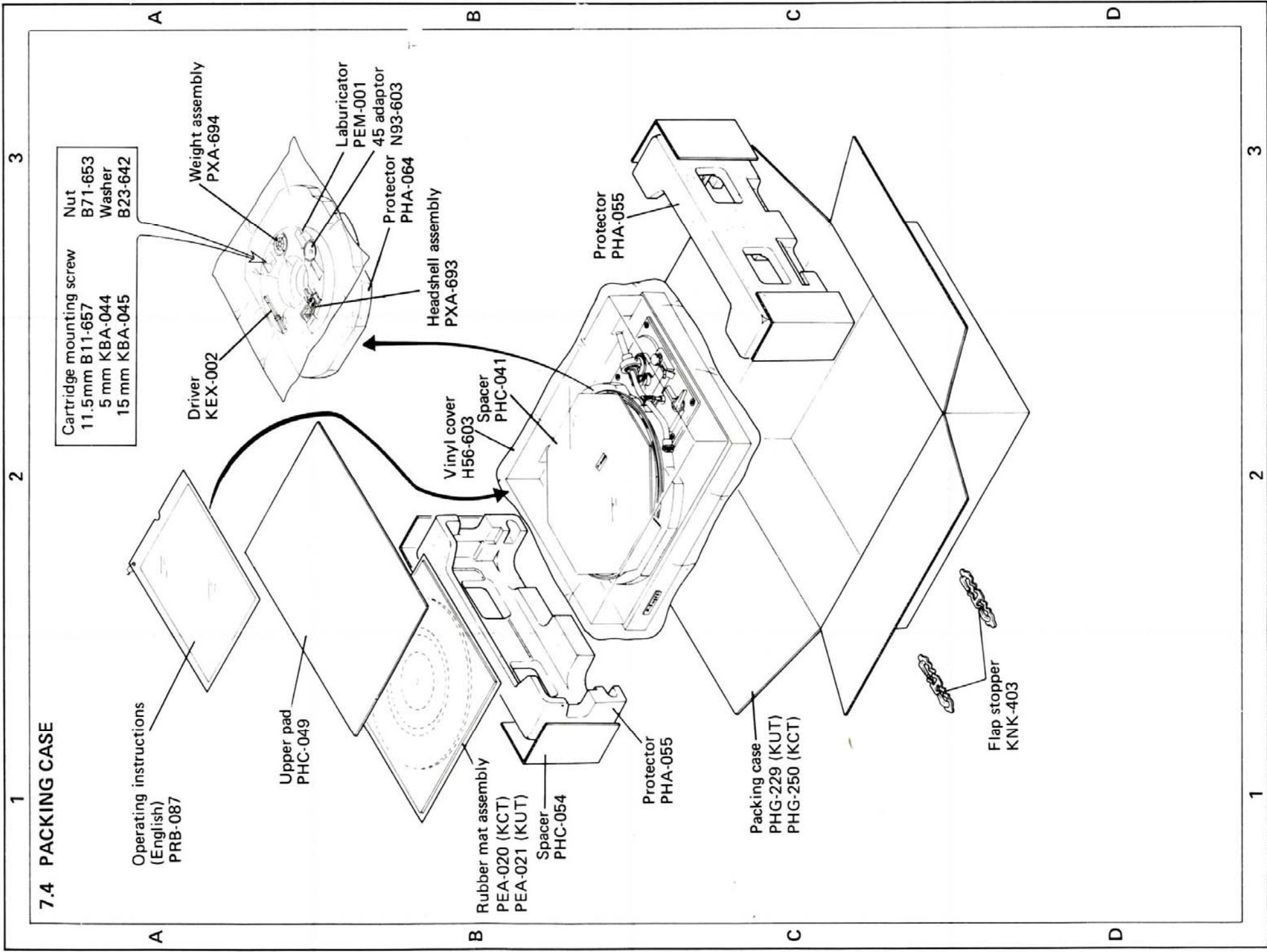









Parts indicated in mark cannot be supplied.



















NOMENCLATURE OF SCREWS, WASHERS AND NUTS

The following symbols stand for screws, washers and nuts as shown in exploded view.

Symbol	Description	Shape
RT	Brazier head tapping screw	
PT	Pan head tapping screw	
BT	Binding head tapping screw	
DPT	Delta tight pan head tapping screw	
APT	Aluminum pan head tapping screw	
QOT	Oval countersunk head tapping screw	
PM	Pan head machine screw	
CM	Countersunk head machine screw	
OCM	Oval countersunk head machine screw	
TM	Truss head machine screw	
BM	Binding head machine screw	
PSA	Pan head screw with spring lock washer	
PSB	Pan head screw with spring lock washer and flat washer	
PSF	Pan head screw with flat washer	

Symbol	Description	Shape
EW	E type washer	
FW	Flat washer	
SW	Spring lock washer	
N	Nut	
WN	Washer faced nut	
ITW	Internal toothed lock washer	
OTW	Outernal toothed lock washer	
SC	Slotted set screw (Cone point)	
SF	Slotted set screw (Flat point)	
HS	Hexagon socket headless set screw	
OCW	Oval countersunk head wood screw	
CW	Countersunk head wood screw	
RW	Round head wood screw	
CS-TW	Stopper washer	

EXAMPLE

