

DIRECT DRIVE 2-motor
FULL AUTOMATIC TURNTABLE

PL-530

SERVICE MANUAL



 PIONEER

MODEL PL-530 COMES IN FOUR VERSIONS DISTINGUISHED AS FOLLOWS:

Type	Voltage	Remarks
KCT	120V only	CSA (Canada) approved model, not provided phono cartridge.
KUT	120V only	UL (U.S.A) approved model, not provided phono cartridge.
S	110V, 120V, 220V and 240V (Switchable)	General export model with phono cartridge
ST	110V, 120V, 220V and 240V (Switchable)	General export model without phono cartridge

This service manual is applicable to the S (S, ST) and K (KCT, KUT) types.

CONTENTS

1. SPECIFICATIONS	4
2. PANEL FACILITIES	5
3. PARTS LOCATIONS	
3.1 Top View	7
3.2 Bottom View	9
4. SCHEMATIC DIAGRAMS, P.C. BOARD PATTERNS AND PARTS LIST	
4.1 S type Schematic Diagrams	11
4.2 Positional Detector Assembly (PWX-007)	13
4.3 Drive Control Assembly (PWG-009)	14
4.4 S type Power Supply Assembly (PWR-821)	17
5. EXPLODED VIEW	19
6. PACKING	30
7. NOMENCLATURE OF SCREW, WASHER AND NUTS	31
8. D.D.MOTOR (PXM-030) OUTLINE OF OPERATION	32
9. D.D. MOTOR TROUBLE SHOOTING CHART	35
10. MECHANISM OPERATION	38
11. ADJUSTMENTS	43
12. K TYPE SCHEMATIC DIAGRAM	46
13. K TYPE POWER SUPPLY ASSEMBLY (PWR-820)	47

PL-530X/ST differs from PL-530 at the point of cabinet appearance; it is black cabinet. Except packing case and cabinet all of components are same as PL-530.

1. SPECIFICATIONS

Motor and Turntable

Motor Brushless DC servo Hall motor
Turntable Platter 330mm diam. aluminum alloy die-cast
Moment of Inertia 260kg·cm² (including platter mat)
Speeds 33-1/3 and 45rpm
Speed Control Range ±2% (individual control for 33-1/3
and 45rpm)
Wow and Flutter Less than 0.03% (WRMS)
Signal-to-Noise Ratio More than 70dB (DIN-B)

Tonearm

Type Static-balance type, S-shaped pipe arm
Effective Arm Length 221mm
Overhang 15.5mm
Usable Cartridge Weight 4g (min.) to 14.5g (max.)
(For cartridge weighs over 9.5g, attach the sub weight)

Furnished Cartridge (S type only)

Type Induced magnet type PC-50
Replacement stylus PN-50
Stylus Tip 0.5mil diamond
Output Voltage 3mV (at 1kHz, 50mm/s RMS)
Tracking Force 1.5g to 2.1g (proper 1.8g)
Frequency Response 10 to 25,000Hz

Subfunctions

Anti-skating force control
Lateral balancer
Stylus pressure direct-readout counterweight
Cueing device
Headshell stand
Strobe light
Free stop hinges

Accessories

45rpm adaptor 1
Overhang gauge 1
Screwdriver 1
Subweight 1
Operating instructions 1

Miscellaneous

Power Requirements AC 110-120-220-240V (switchable)
50/60Hz S type
AC 120V 60Hz K type
Power Consumption 7W
Dimensions 480(W) x 170(H) x 390(D)mm
17-7/8(W) x 6-11/16(H) x 15-3/8(D)in.
Weight 10kg/22lb

ST. KCT. KUT type only

Cartridge mounting screws 6
Cartridge mounting nuts 2
Cartridge mounting washers 2

NOTE:

Specifications and design subject to possible modification without notice, due to improvements.

2. PANEL FACILITIES

HEADSHELL STAND

Store your spare cartridge here. Insert cartridge, aligning cartridge guide pin with groove in the headshell stand. The 45 rpm adaptor can also be kept here.

NOTE:

Depending on how the headshell is inserted, it can contact the platter or dust cover. Be careful to insert it with the finger lift pointed inward.

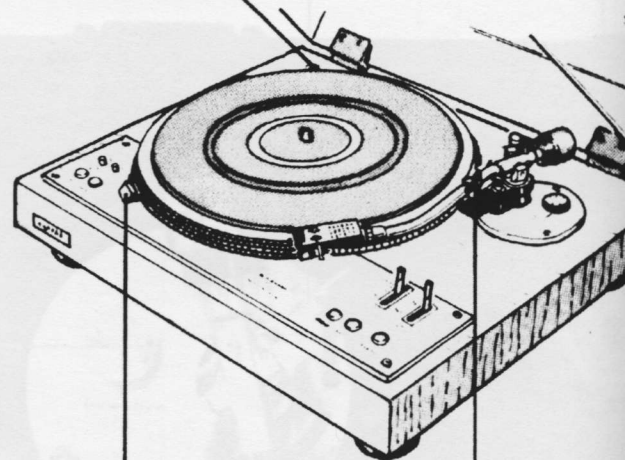
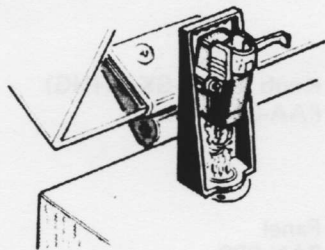

45 RPM ADAPTOR

Place over the center shaft when playing 45 rpm EP (large hole) records.



STROBE LIGHT

When the platter rotates, this lamp lights stroboscopically.

33-1/3 RPM SPEED FINE ADJUSTMENT KNOB

Perform fine adjustment of 33-1/3 rpm speed with this knob, while watching the strobe marks. When this knob is turned in the "+" direction, the speed increases; when turned in the "-" direction, the speed decreases. (Refer to instructions for FINE ADJUSTMENT OF SPEED on page 10.)

45 RPM SPEED FINE ADJUSTMENT KNOB

Perform fine adjustment of 45 rpm speed with this knob, while watching the strobe marks. When this knob is turned in the "+" direction, the speed increases; when turned in the "-" direction, the speed decreases. (Refer to instruction for FINE ADJUSTMENT OF SPEED on page 10.)

33-1/3 RPM BUTTON [33]

Push this button when playing a 33-1/3rpm record.

45 RPM BUTTON [45]

Push this button when playing a 45-rpm record.

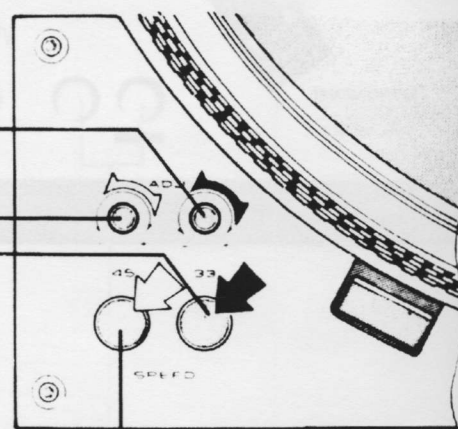

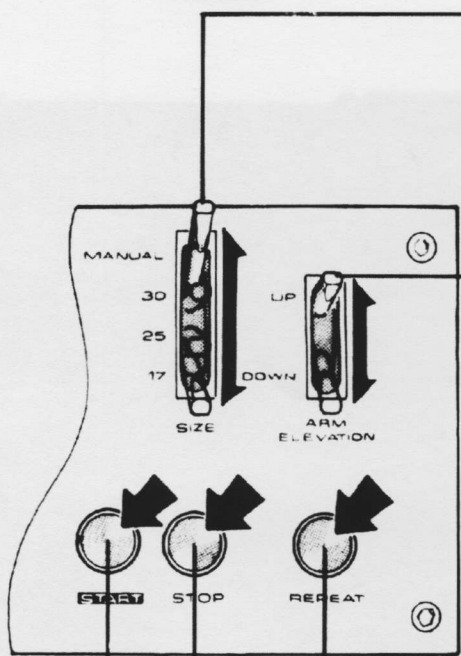

RECORD SIZE SELECTOR

Operating this lever enables the turntable to be switched from manual to automatic operation.

- MANUAL . . .** Set here to operate tonearm manually.
- 30** Set here to play 30 cm LP records automatically.
- 25** Set here to play 25 cm LP records automatically.
- 17** Set here to play 17 cm records automatically.

NOTE:

For automatic playing, always switch the record size selector before pushing the START button. If the record size selector is switched while the tonearm is in motion, the stylus may not descend at the correct position or it may move to the new position while contacting the record surface causing record and stylus damage.

ARM LIFT LEVER

The tonearm is raised and lowered with this lever.

- UP** Moving the lever to this position raises the tonearm manually.
- DOWN** Moving the lever to this position lowers the tonearm manually. Leave the lever here for automatic operation.

FUNCTION SELECTOR BUTTONS

- REPEAT** Push this button to play the same record over and over. To release the repeat function, push the STOP button.
- STOP** When this button is pushed while a record is being played, the tonearm returns to the arm rest. Then the platter stops rotating and power source is shut off.
- START** When this button is pushed, the platter starts rotating. When the record size selector is set to an automatic position, the tonearm moves to the designated position and begins playing.

ARM REST

The arm rest supports the tonearm when it is not in use. When the turntable is not being used for a while, close the clamp around the tonearm as shown in the figure.

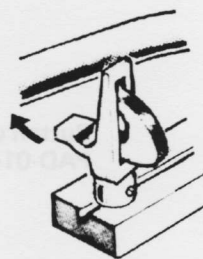

Open the clamp

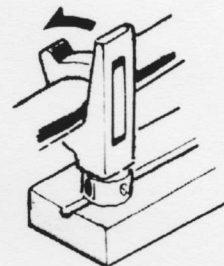

Close the clamp

3. PARTS LOCATION

3.1 TOP VIEW

RECORD SIZE SELECTOR
Opening this lever shifts the transfer to be switched
from record to automatic operation.
Set lever to give 30 cm LP records auto-
matically.
Set lever to give 17 cm records auto-
manually.

NOTE
For automatic operation always switch the record size
before record button is pushed. If the record
size selected is not correct at the correct position of the
lever, the record will be damaged at the correct position of the
lever. Do not force the lever position while operating the
record without causing record and stylus damage.

RECORD LIFT LEVER
When the record is placed with the
stylus on the record and lowered with the
lever, the lever to this position takes
the record manually.
When the lever is in this position lower
the automatic manually. Lower the lever
for automatic operation.

FUNCTION SELECTOR BUTTONS
Push the button to play the same record
over and over. To return the record func-
tion with the STOP button.
When the button is pushed while a record
is being played, the transport returns to
the rest position. When the button is
pushed and power source is shut off,
the record will be pushed, the player
will return to an automatic position,
the transport will be deenergized
and the record will be damaged.

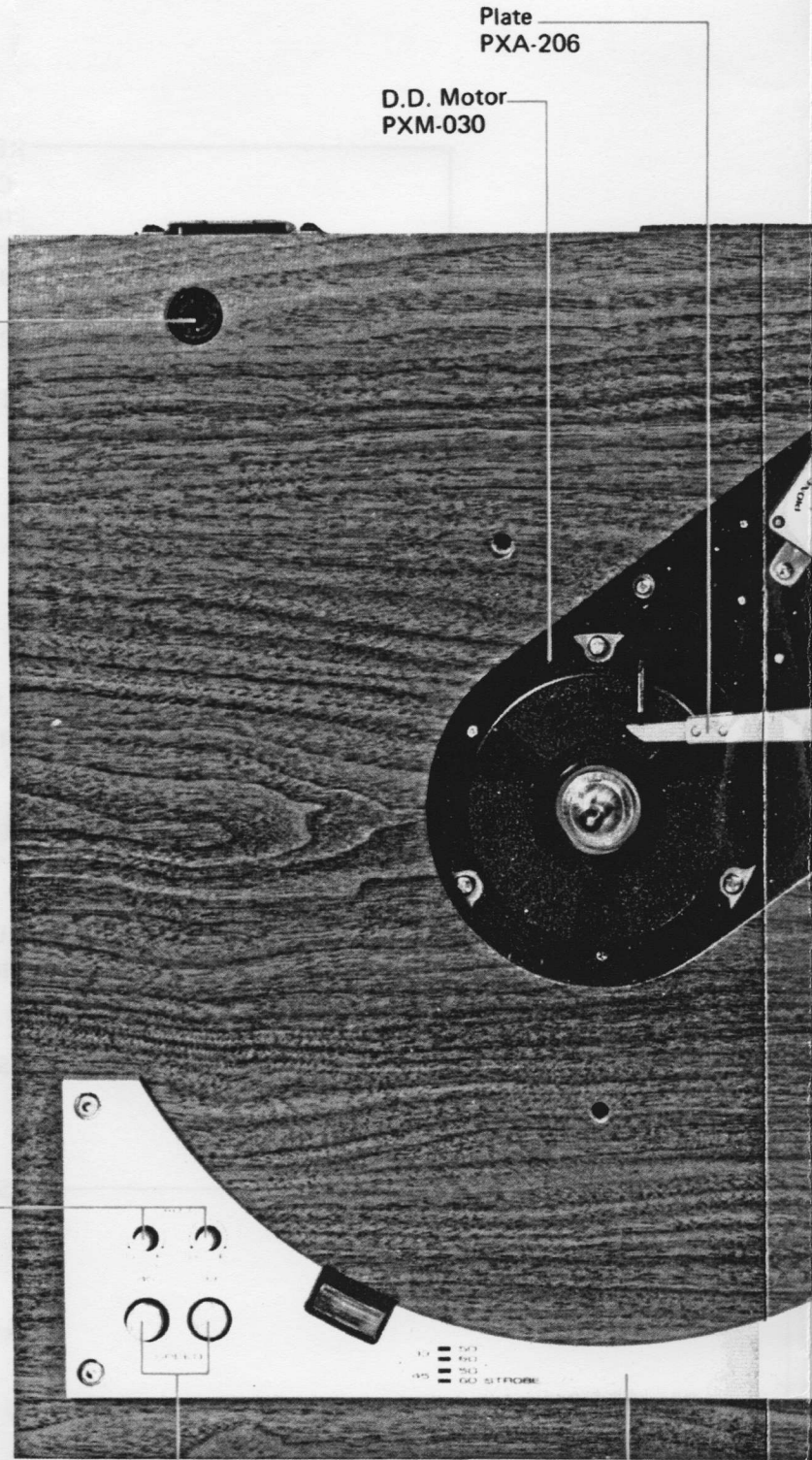

Headshell stand
PNW-073

Variable resistor
PCS-008

Button unit
PAD-014

Control panel
PAN-036

D.D. Motor
PXM-030

Plate
PXA-206

Head
PXA-

Timing motor
PXM-037

Lateral weight
KLA-438

Weight assembly
PXA-599

Knob (ANTI-SKATING)
PAA-017

Panel
PAN-032

Tone arm assembly
PPD-546

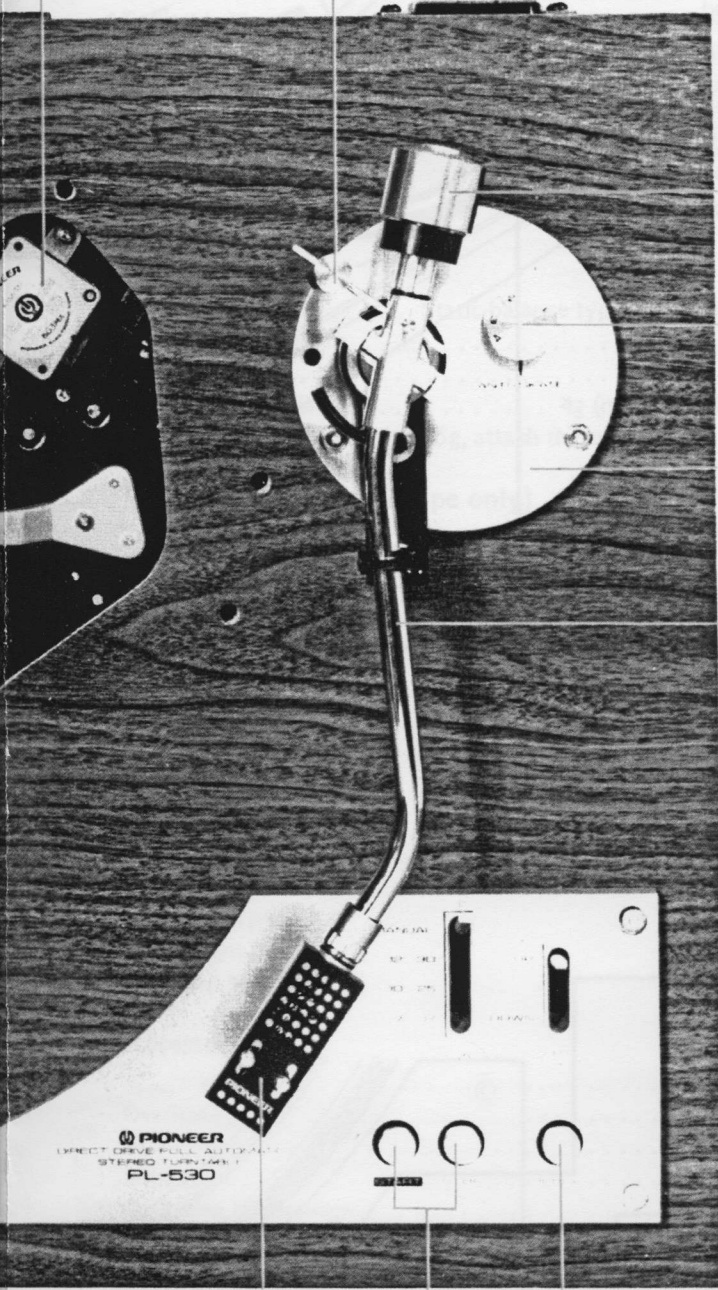

Button unit (REPEAT)
PAD-016

Button unit (START, STOP)
PAD-015

Shell assembly
-630

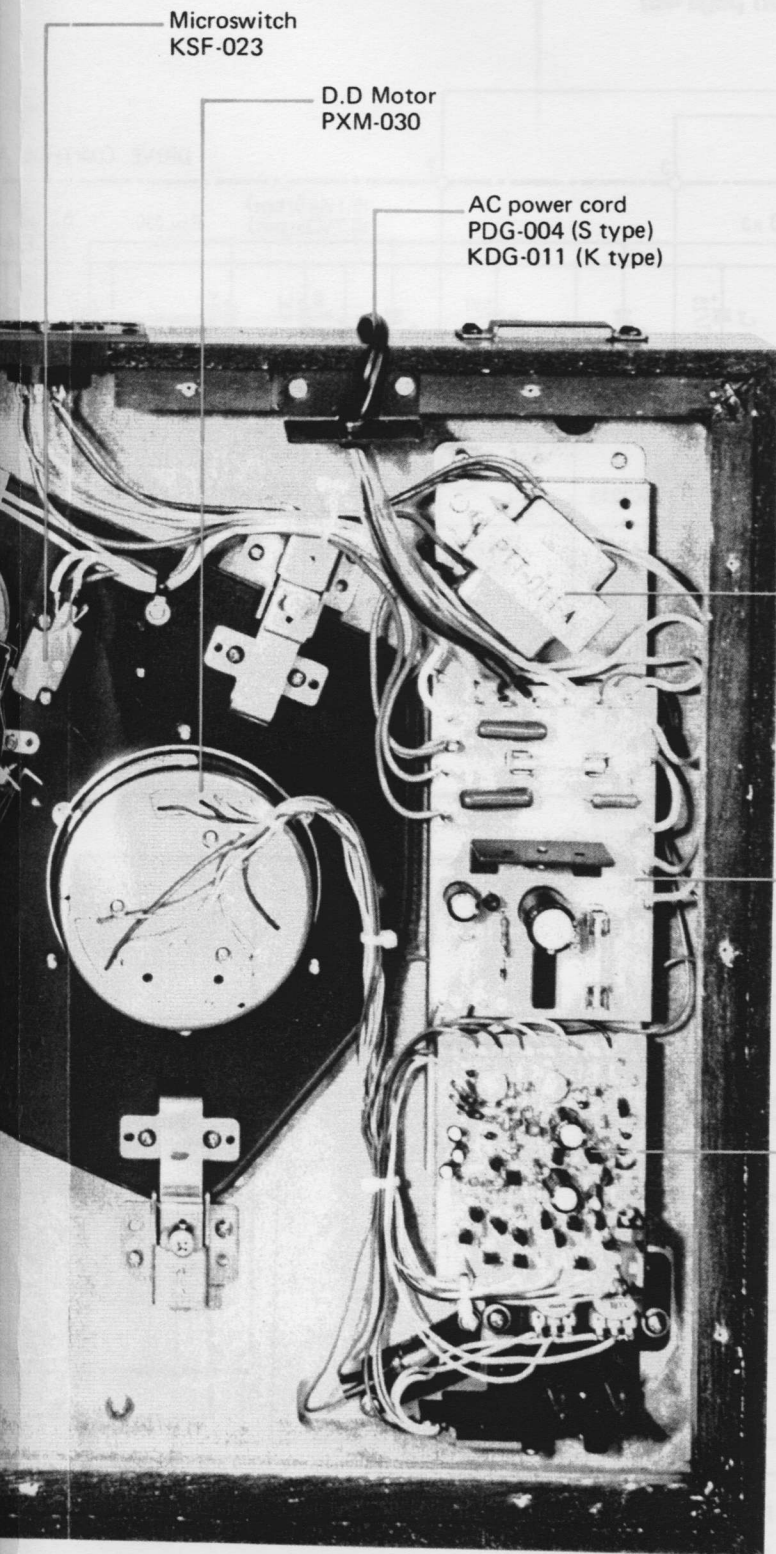

Microswitch
KSF-023

D.D Motor
PXM-030

AC power cord
PDG-004 (S type)
KDG-011 (K type)

Power transformer
PTT-020 (S type)
PTT-017 (K type)

Power supply assembly
PWR-821 (S type)
PWR-820 (K type)

Drive control assembly
PWG-009

4. SCHEMATIC DIAGRAMS, P.C. BOARD PATTERNS AND

4.1 S type SCHEMATIC DIAGRAMS (K type on page 46)

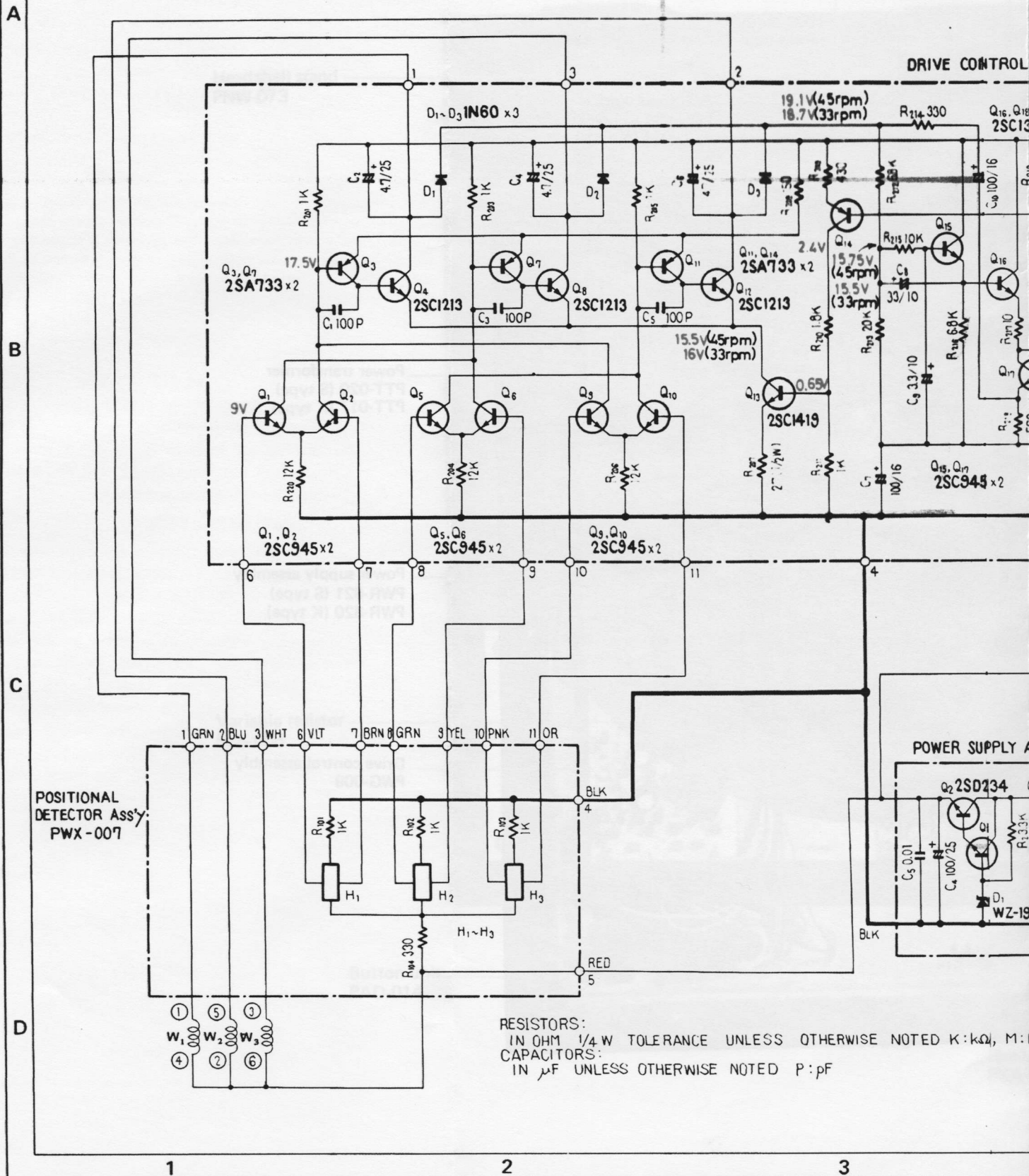

PARTS LIST

A

B

C

D

Ass'y PWG-009

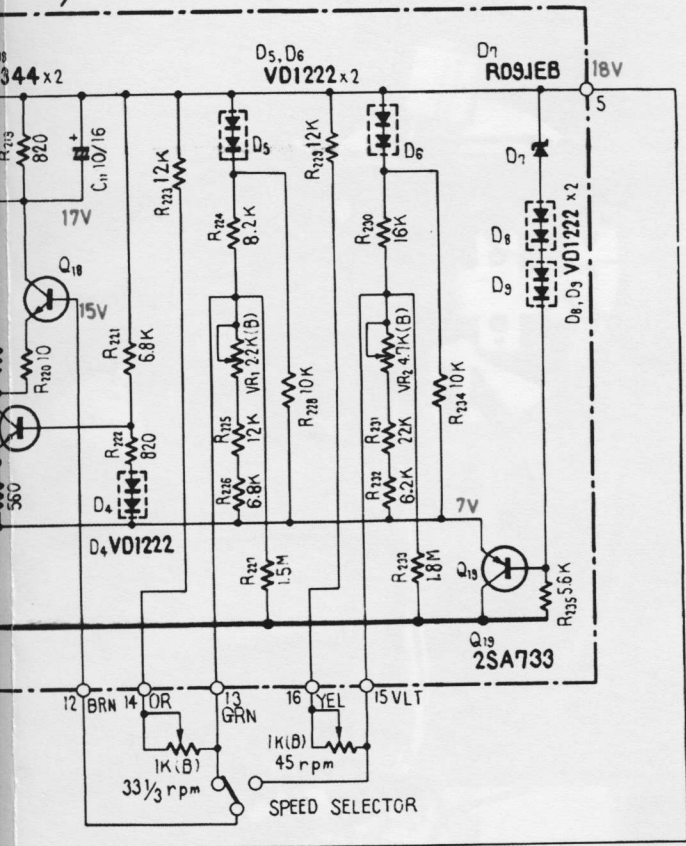

Ass'y PWR-821

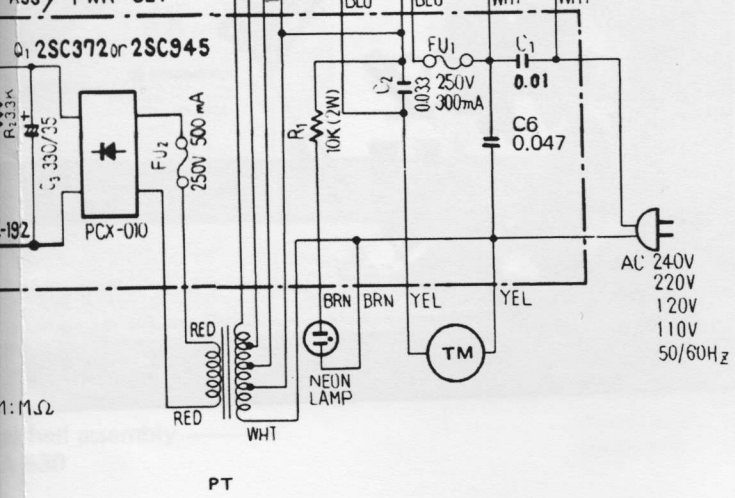

Parts List

Symbol	Description	Part No.
	Drive control assembly	PWG-009
	Positional detector assembly	PWX-007
	Power supply assembly (S, ST)	PWR-821
	Power supply assembly (KCT, KUT)	PWR-820
SW1	Microswitch	KSF-023
SW2	Microswitch	KSF-023
	Line voltage selector	PSB-001
	Neon lamp	PEL-005
TM	Timing motor	PXM-037
PT	Power transformer (S type)	PTT-020
	Power transformer (K type)	PTT-017
	Speed selector switch	KSF-023
	Speed adjustment volume (1k-B)	PCS-008

4.2 POSITIONAL DETECTOR ASSEMBLY (PWX-007)

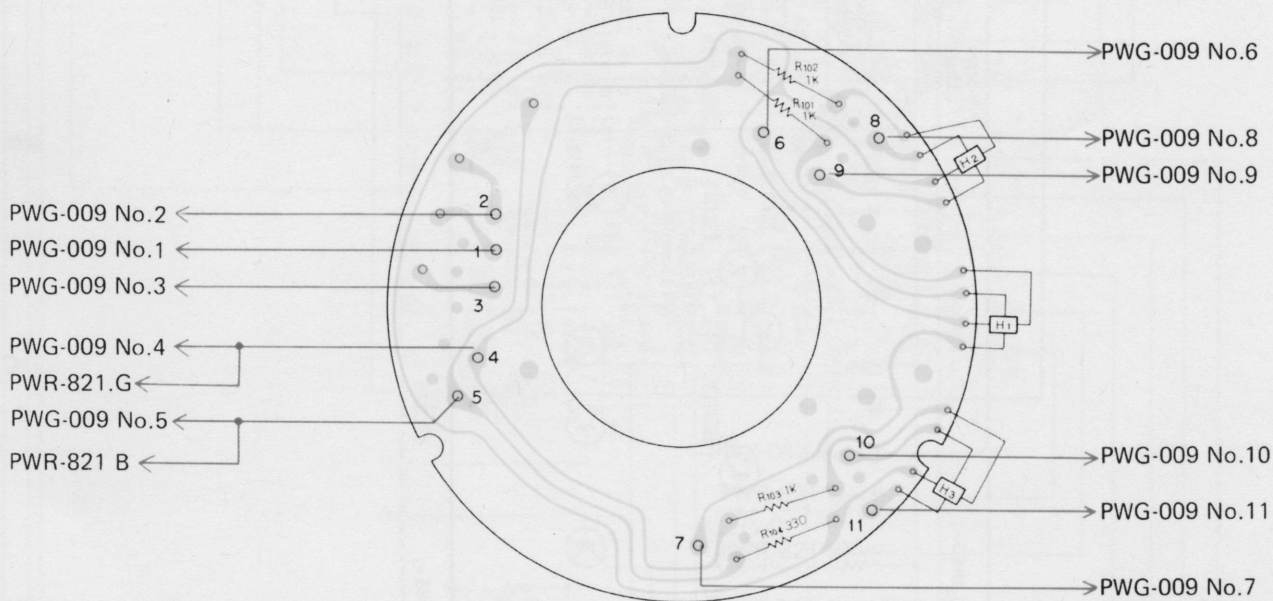
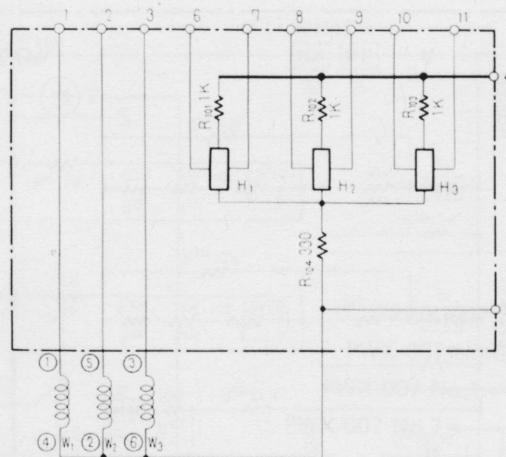

Part List

RESISTORS

Symbol	Description	Part No.
R101	Carbon film 1k-	RD¼PS 102J
R102	Carbon film 1k	RD¼PS 102J
R103	Carbon film 1k	RD¼PS 102J
R104	Carbon film 330	RD¼PS 331J

OTHERS

Symbol	Description	Part No.
H1	Hall element	PCX-012
H2	Hall element	PCX-012
H3	Hall element	PCX-012

4.3 DRIVE CONTROL ASSEMBLY (PWG-009)

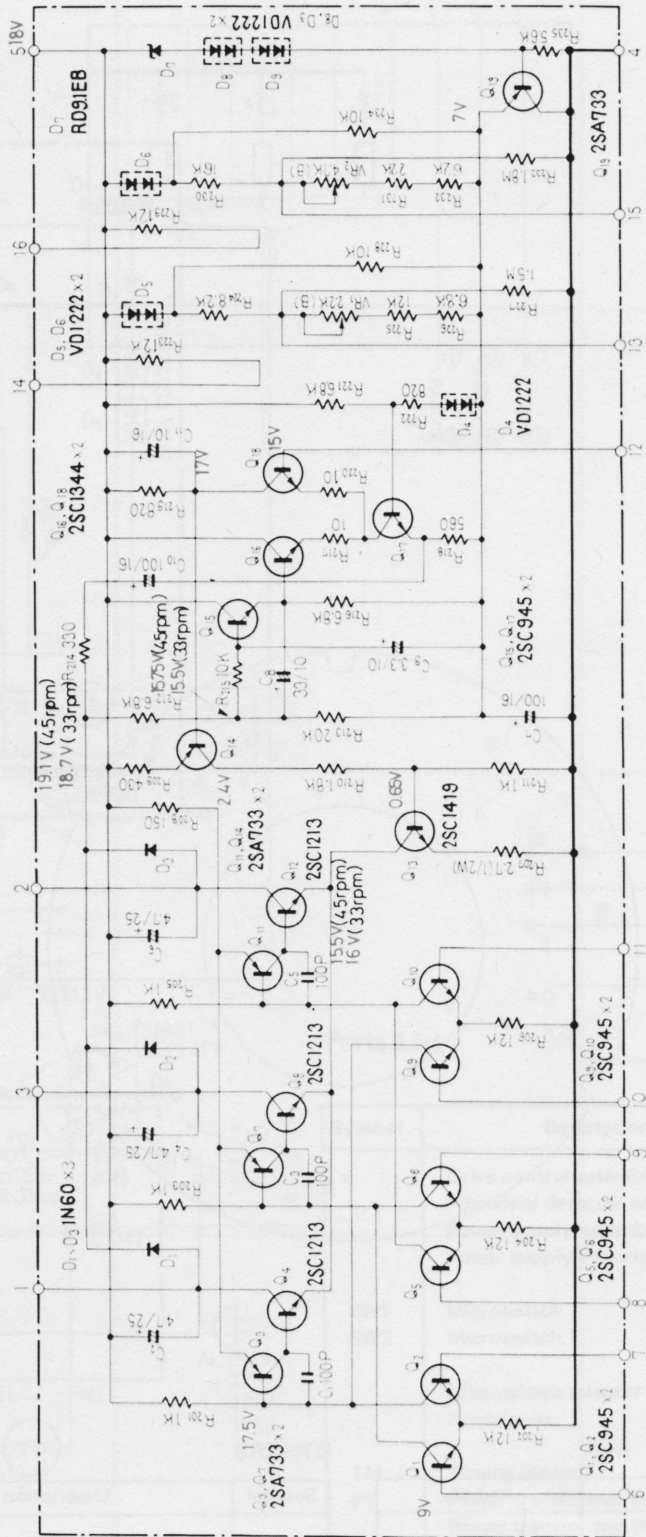

A

B

C

D

A

B

C

D

1

2

3

1

2

3

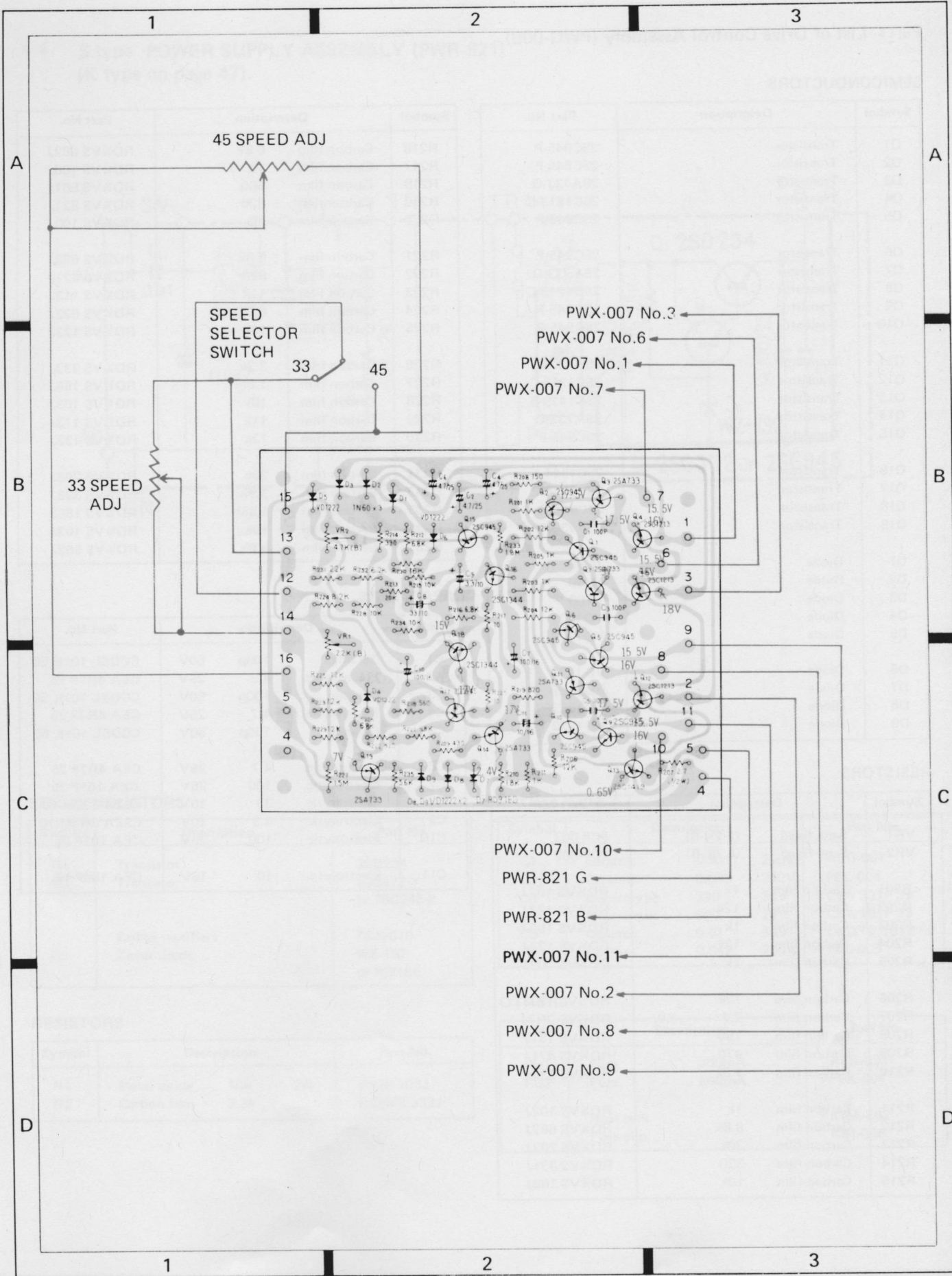

Parts List of Drive Control Assembly (PWG-009)

SEMICONDUCTORS

Symbol	Description	Part No.
Q1	Transistor	2SC945-P
Q2	Transistor	2SC945-P
Q3	Transistor	2SA 733-Q
Q4	Transistor	2SC 1213-C
Q5	Transistor	2SC945-P
Q6	Transistor	2SC945-P
Q7	Transistor	2SA 733-Q
Q8	Transistor	2SC 1213-C
Q9	Transistor	2SC945-P
Q10	Transistor	2SC945-P
Q11	Transistor	2SA 733-Q
Q12	Transistor	2SC 1213-C
Q13	Transistor	2SC 1419-B
Q14	Transistor	2SA 733-Q
Q15	Transistor	2SC945-P
Q16	Transistor	2SC1344-E
Q17	Transistor	2SC1344-E
Q18	Transistor	2SC945-P
Q19	Transistor	2SA 733-Q
D1	Diode	1N60
D2	Diode	1N60
D3	Diode	1N60
D4	Diode	VD1222
D5	Diode	VD1222
D6	Diode	VD1222
D7	Diode	RD91EB
D8	Diode	VD1222
D9	Diode	VD1222

RESISTORS

Symbol	Description	Part No.
VR1	Semi-fixed (2.2K-B)	PCP-003
VR2	Semi-fixed (4.7K-B)	PCP-002
R201	Carbon film 1k	RD¼VS 102J
R202	Carbon film 12k	RD¼VS 123J
R203	Carbon film 1k	RD¼VS 102J
R204	Carbon film 12k	RD¼VS 123J
R205	Carbon film 1k	RD¼VS 102J
R206	Carbon film 12k	RD¼VS 123J
R207	Carbon film 2.7 ½W	RD½VS 2R7J
R208	Carbon film 150	RD¼VS 151J
R209	Carbon film 470	RD¼VS 471J
R210	Carbon film 1.8k	RD¼VS 182J
R211	Carbon film 1k	RD¼VS 102J
R212	Carbon film 6.8k	RD¼VS 682J
R213	Carbon film 20k	RD¼VS 203J
R214	Carbon film 330	RD¼VS 331J
R215	Carbon film 10k	RD¼VS 103J

Symbol	Description	Part No.
R216	Carbon film 6.8k	RD¼VS 682J
R217	Carbon film 10	RD¼VS 100J
R218	Carbon film 560	RD¼VS 561J
R219	Carbon film 820	RD¼VS 821J
R220	Carbon film 10	RD¼VS 100J
R221	Carbon film 6.8k	RD¼VS 682J
R222	Carbon film 820	RD¼VS 821J
R223	Carbon film 11k	RD¼VS 113J
R224	Carbon film 6.2k	RD¼VS 622J
R225	Carbon film 12k	RD¼VS 123J
R226	Carbon film 3.3k	RD¼VS 332J
R227	Carbon film 1.5M	RD¼VS 155J
R228	Carbon film 10k	RD¼VS 103J
R229	Carbon film 11k	RD¼VS 113J
R230	Carbon film 13k	RD¼VS 133J
R231	Carbon film 20k	RD¼VS 203J
R232	Carbon film 3.9k	RD¼VS 392J
R233	Carbon film 1.8M	RD¼VS 185J
R234	Carbon film 10k	RD¼VS 103J
R235	Carbon film 5.6k	RD¼VS 562J

CAPACITORS

Symbol	Description	Part No.
C1	Ceramic 100p 50V	CCDSL 101K 50
C2	Electrolytic 4.7 25V	CEA 4R7P 25
C3	Ceramic 100p 50V	CCDSL 101K 50
C4	Electrolytic 4.7 25V	CEA 4R7P 25
C5	Ceramic 100p 50V	CCDSL 101K 50
C6	Electrolytic 4.7 25V	CEA 4R7P 25
C7	Electrolytic 100 25V	CEA 101P 25
C8	Electrolytic 33 10V	CSZA 330M 10
C9	Electrolytic 3.3 10V	CSZA 3R3M 10
C10	Electrolytic 100 25V	CEA 101P 25
C11	Electrolytic 10 16V	CEA 100P 16

A

B

C

D

4.4 S type POWER SUPPLY ASSEMBLY (PWR-821)
(K type on page 47).

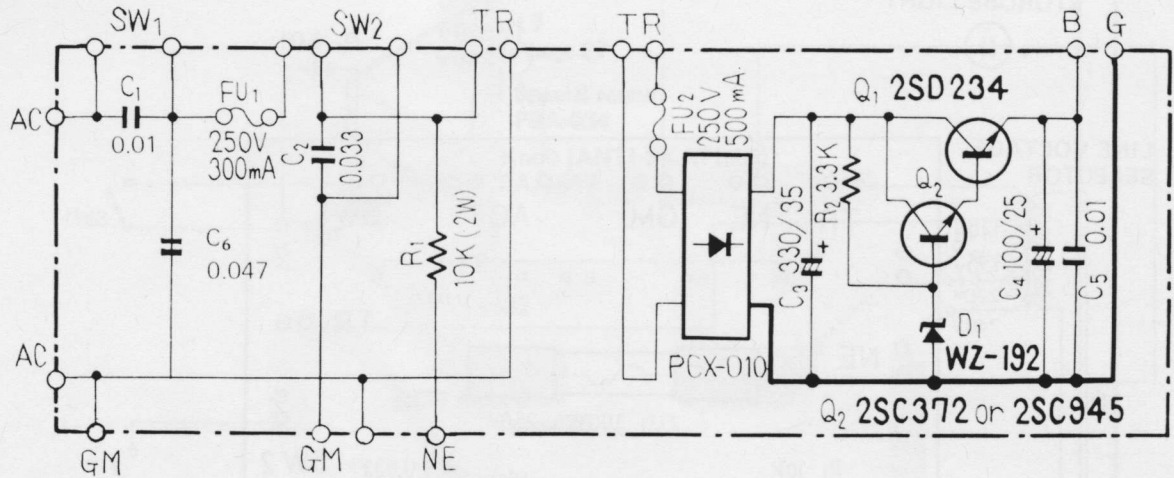

SEMICONDUCTORS

Symbol	Description	Part No.
Q1	Transistor	2SD234
Q2	Transistor	2SC372-Y or 2SC945-P
D1	Bridge rectifiers Zener diode	PCX-010 WZ-192 or RD18E

CAPACITORS

Symbol	Description	Part No.
C1	Ceramic 0.01 250V	ACG-001
C2	Ceramic 0.033 250V	PCL-004
C3	Electrolytic 330 35V	CEA 331P 35
C4	Electrolytic 100 25V	CEA 101P 25
C5	Ceramic 0.01 50V	CKDYF 103Z 50
C6	Ceramic 0.047 250V	PCL-005

RESISTORS

Symbol	Description	Part No.
R1	Metal oxide 10k 2W	RS2P 103J
R2	Carbon film 3.3k	RD¼PS 332J

OTHERS

Symbol	Description	Part No.
FU1	Fuse 300mA	AEK-023
FU2	Fuse 500mA	PEK-004
	Heat sink	KNA-582
	Fuse clip	K91-006

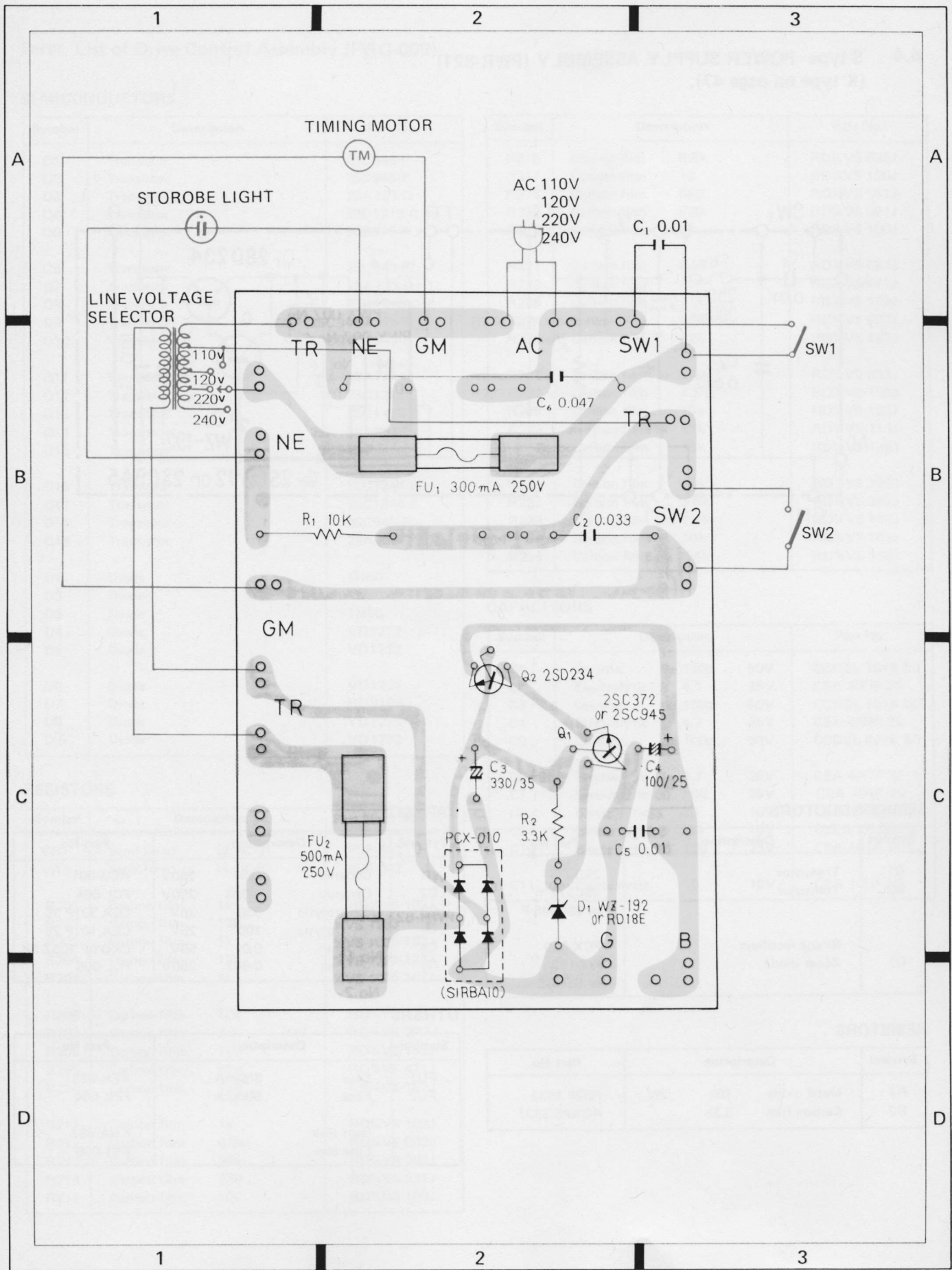

5. EXPLODED VIEW

A
B
C
D

1 2 3

Dust cover
PNV-008

Hing
PXA-070

Special screw
PBA-034

Control pan
PAN-036
PAN-037 (K)

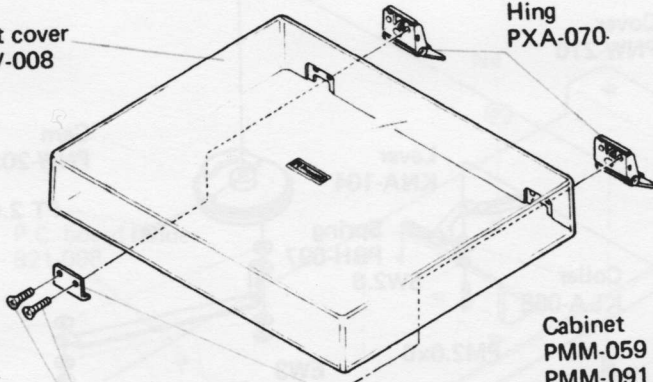

Holder (A)
PNW-193

Lens
PNW-239

Holder (B)
PNW-194

PSA4x10

Headshell stand
PNW-073

Ring
KAH-007

Rubber mat

Platter

Platter assembly
PXA-200

Pin

Speed selector assembly
PXA-197

Part 4
See page 25

Name plate

Plate
PNB-242

Screw
PBA-040

RWS 3.1x10

Part 2
See page 23

Part 1
See page 2

PSA 4x10

PT3x5

Spring
PBK-010

Angle

PT3x5

PT3x5

Screw
PBA-029

PT3x5

Angle

1 2 3

4

5

6

NOTE:

Parts indicated in green type cannot be supplied.

panel
6
7 (PL-530X)

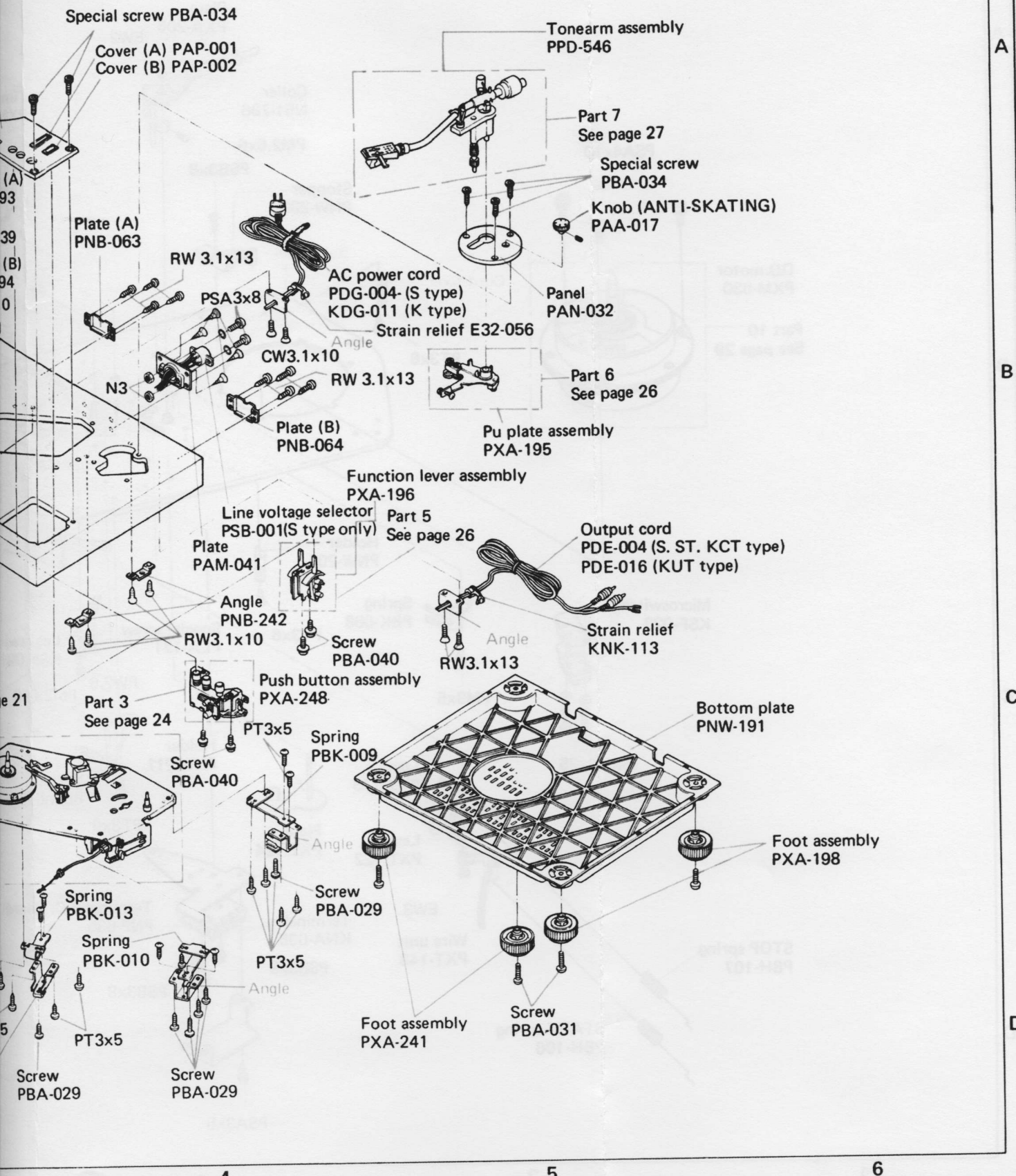

A

B

C

D

4

5

6

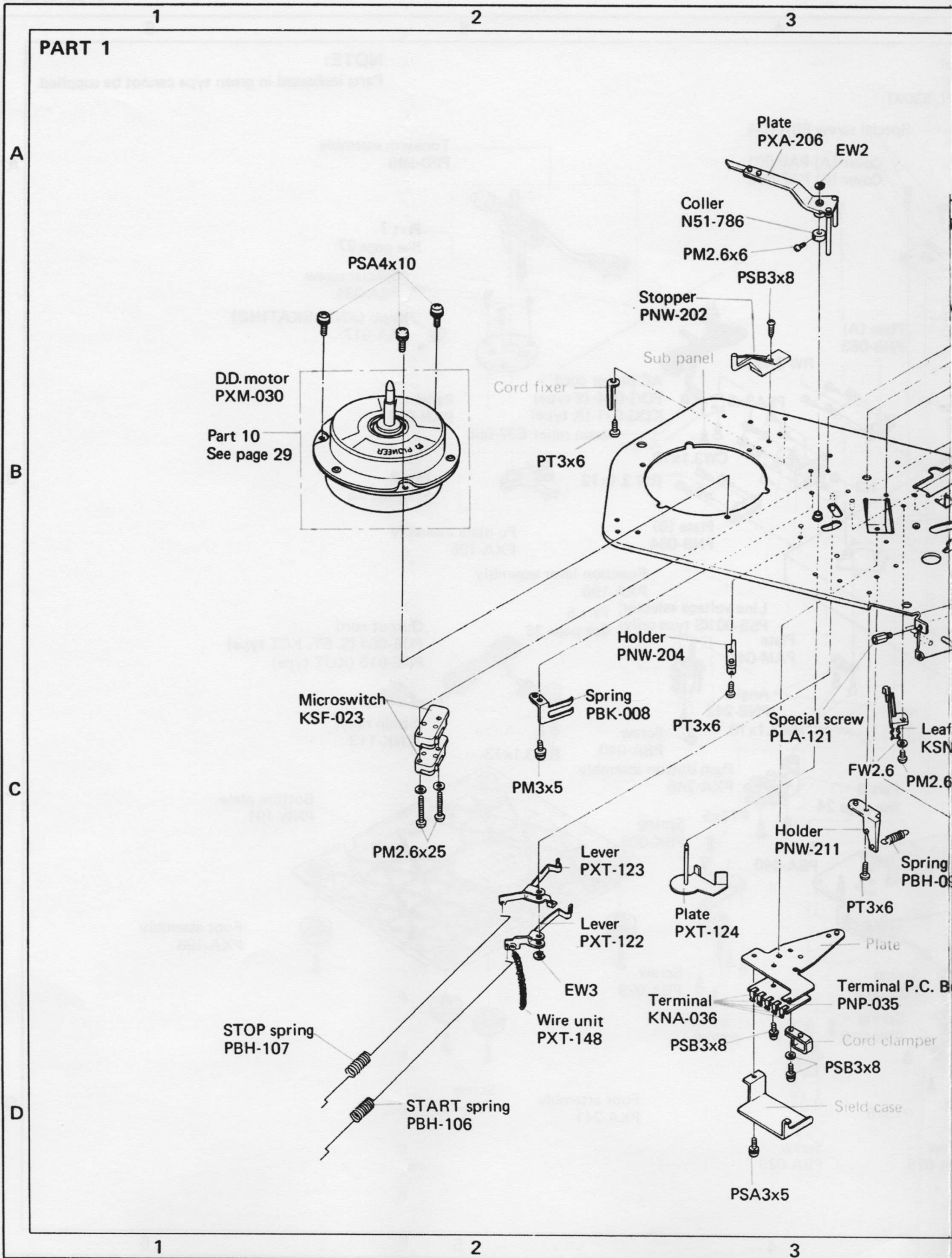

4

5

6

NOTE:

Parts indicated in green type cannot be supplied.

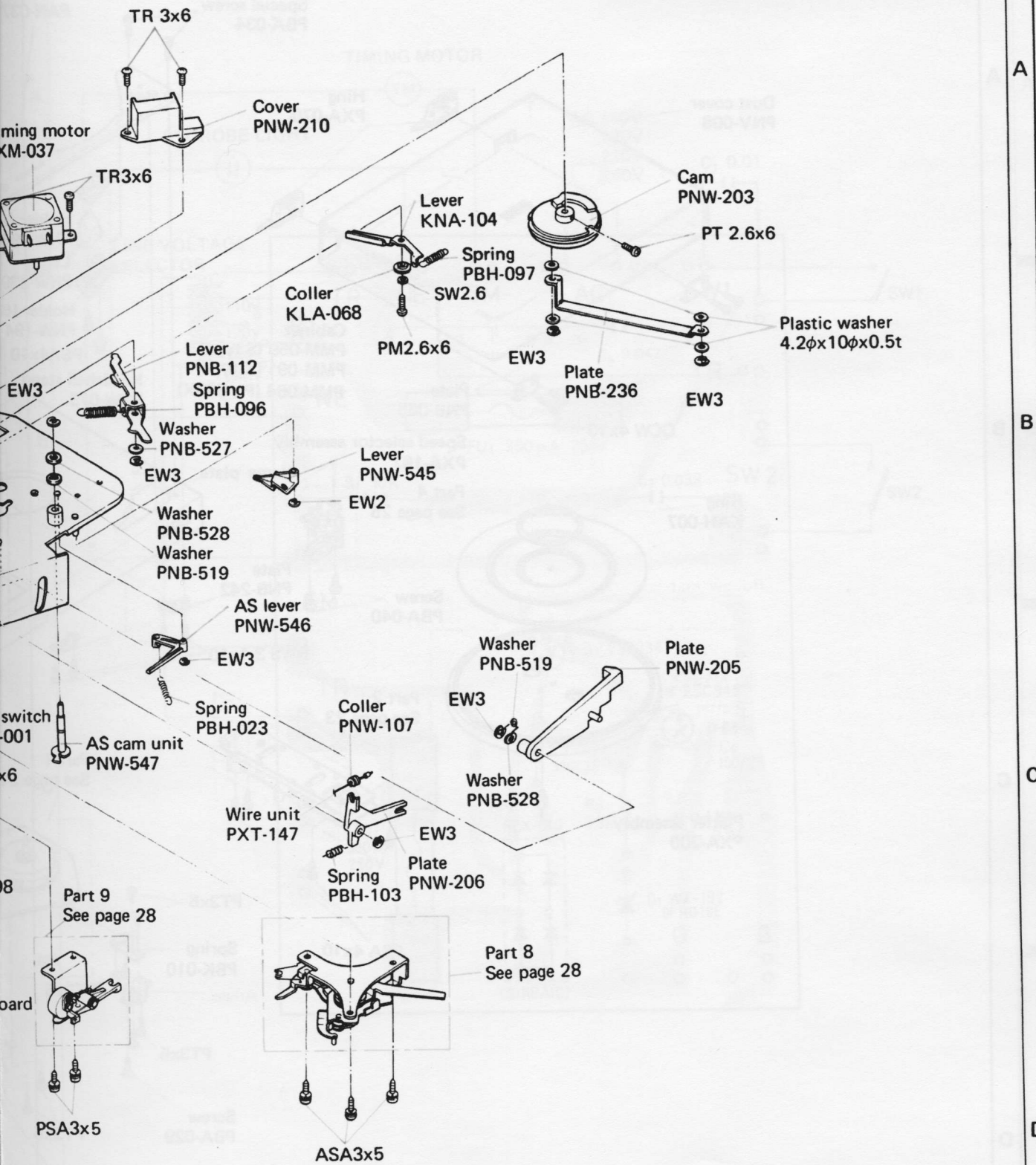

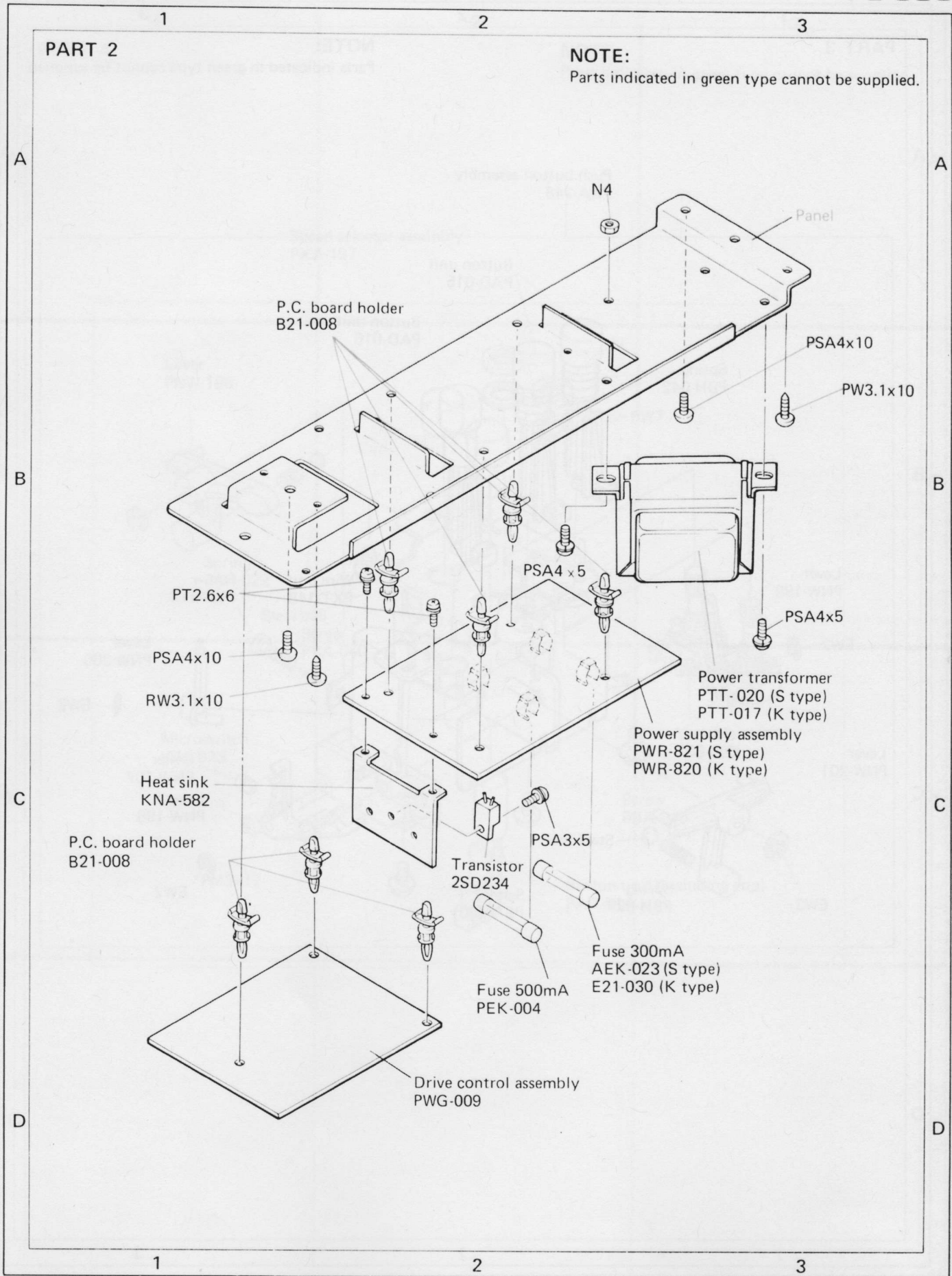

PART 3

NOTE:
Parts indicated in green type cannot be supplied.

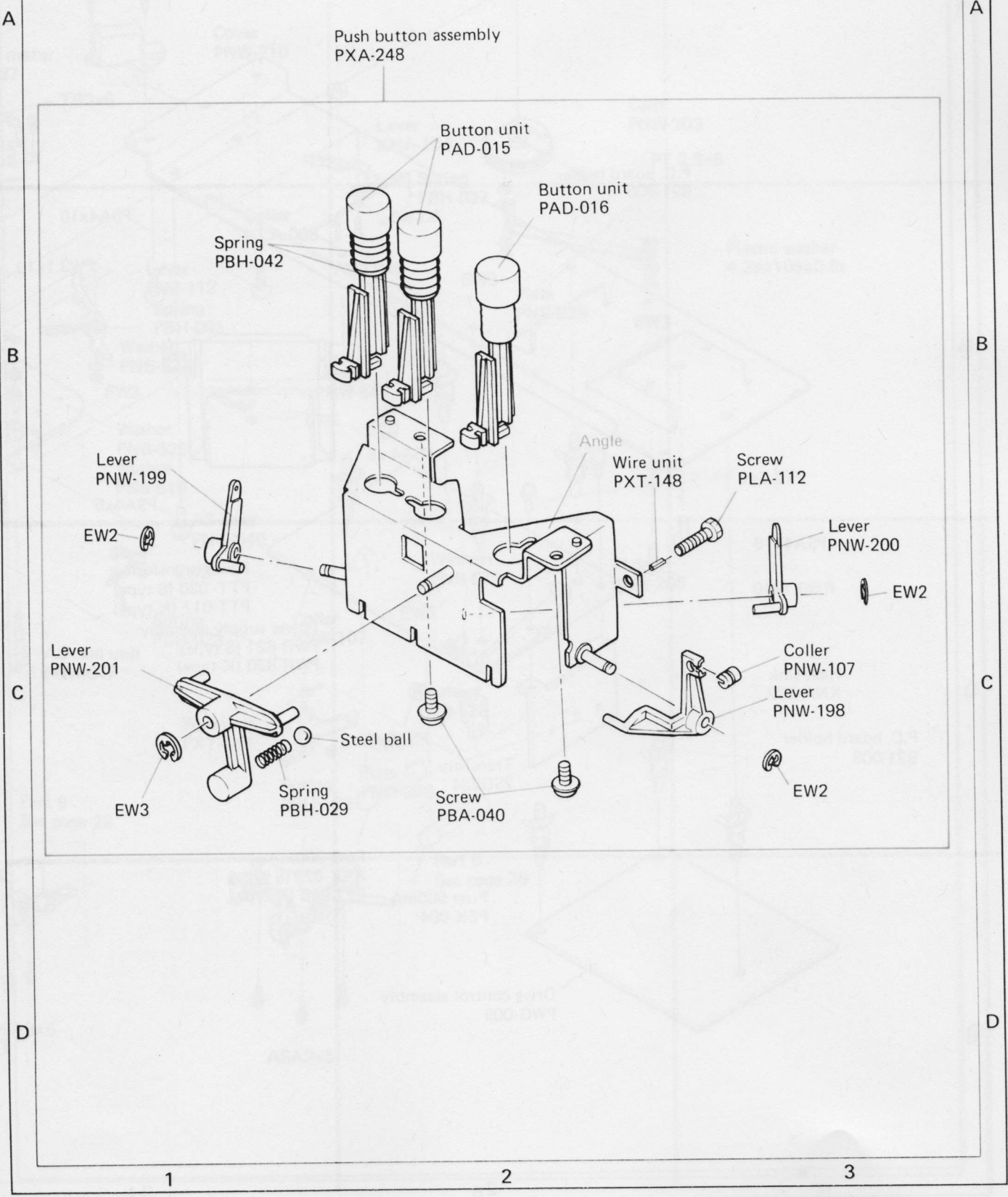

PART 4

NOTE:
Parts indicated in green type cannot be supplied.

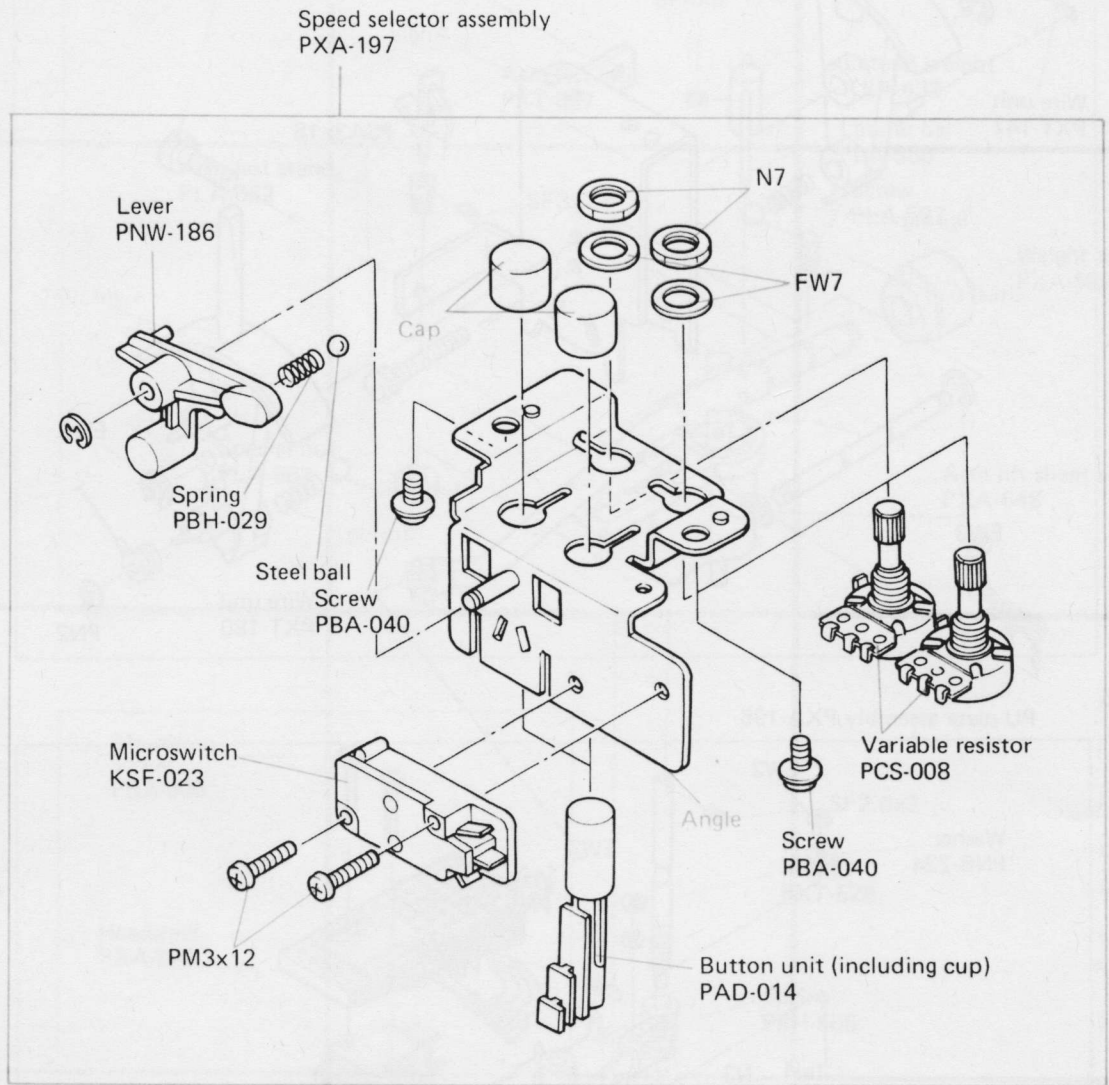

1

2

3

PART 5

Function lever assembly
PXA-196

NOTE:

Parts indicated in green type cannot be supplied.

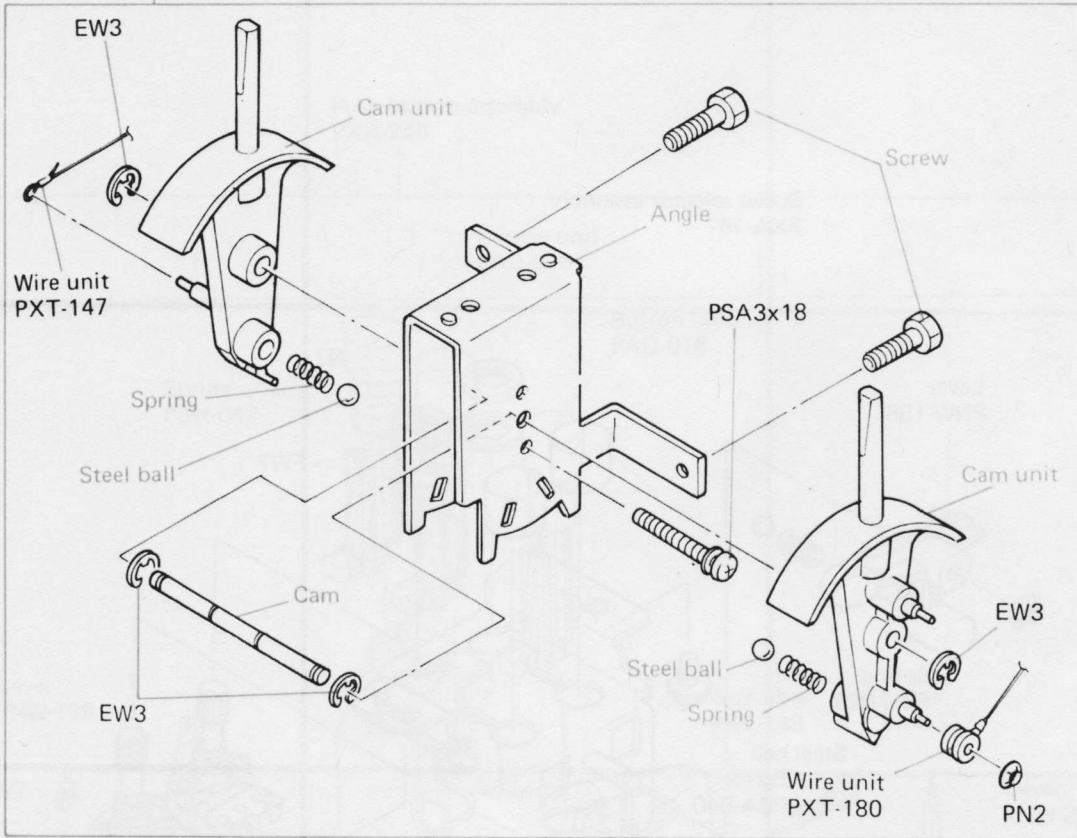

PART 6

PU plate assembly PXA-195

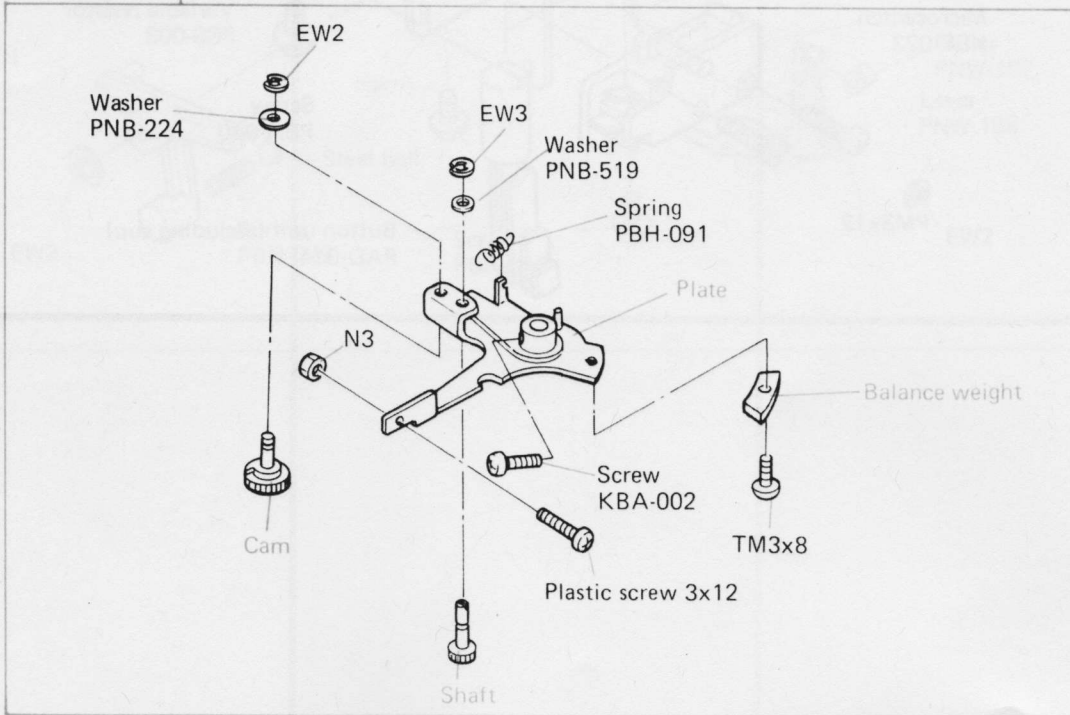

1

2

3

PART 7

NOTE:

Parts indicated in green type cannot be supplied.

Tonearm assembly (PPD-546)

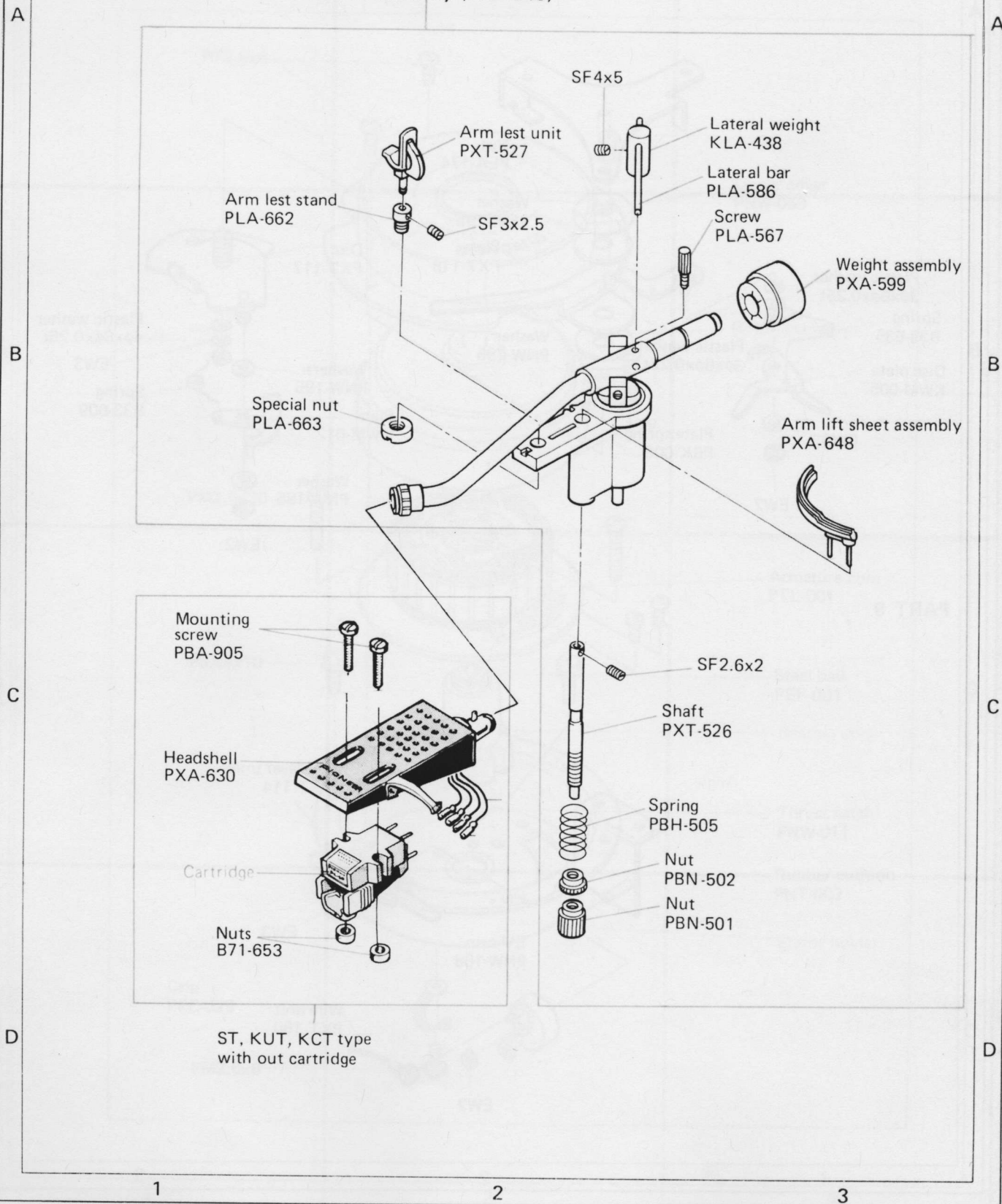

ST, KUT, KCT type with out cartridge

PART 8

NOTE:
Parts indicated in green type cannot be supplied.

A

A

B

B

C

C

D

D

1

2

3

1

2

3

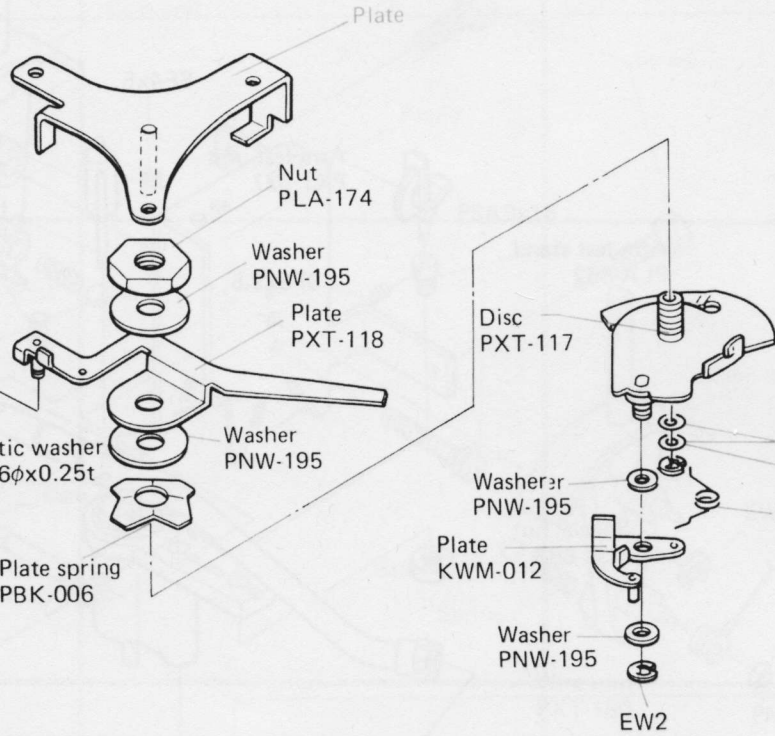

PART 9

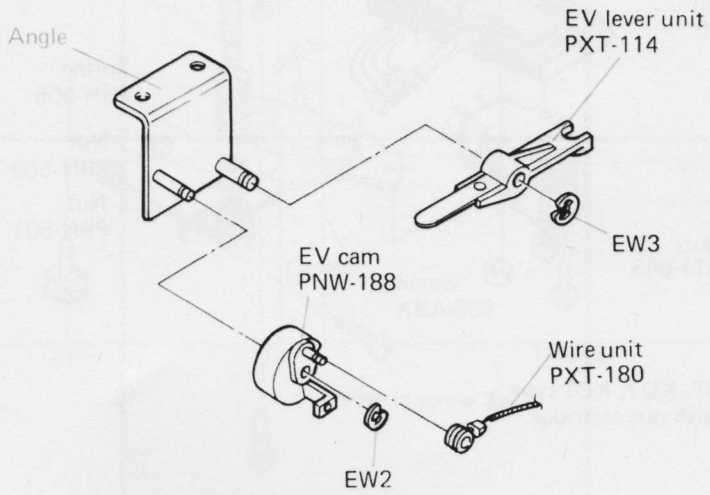

PART 10

NOTE:

Parts indicated in green type cannot be supplied.

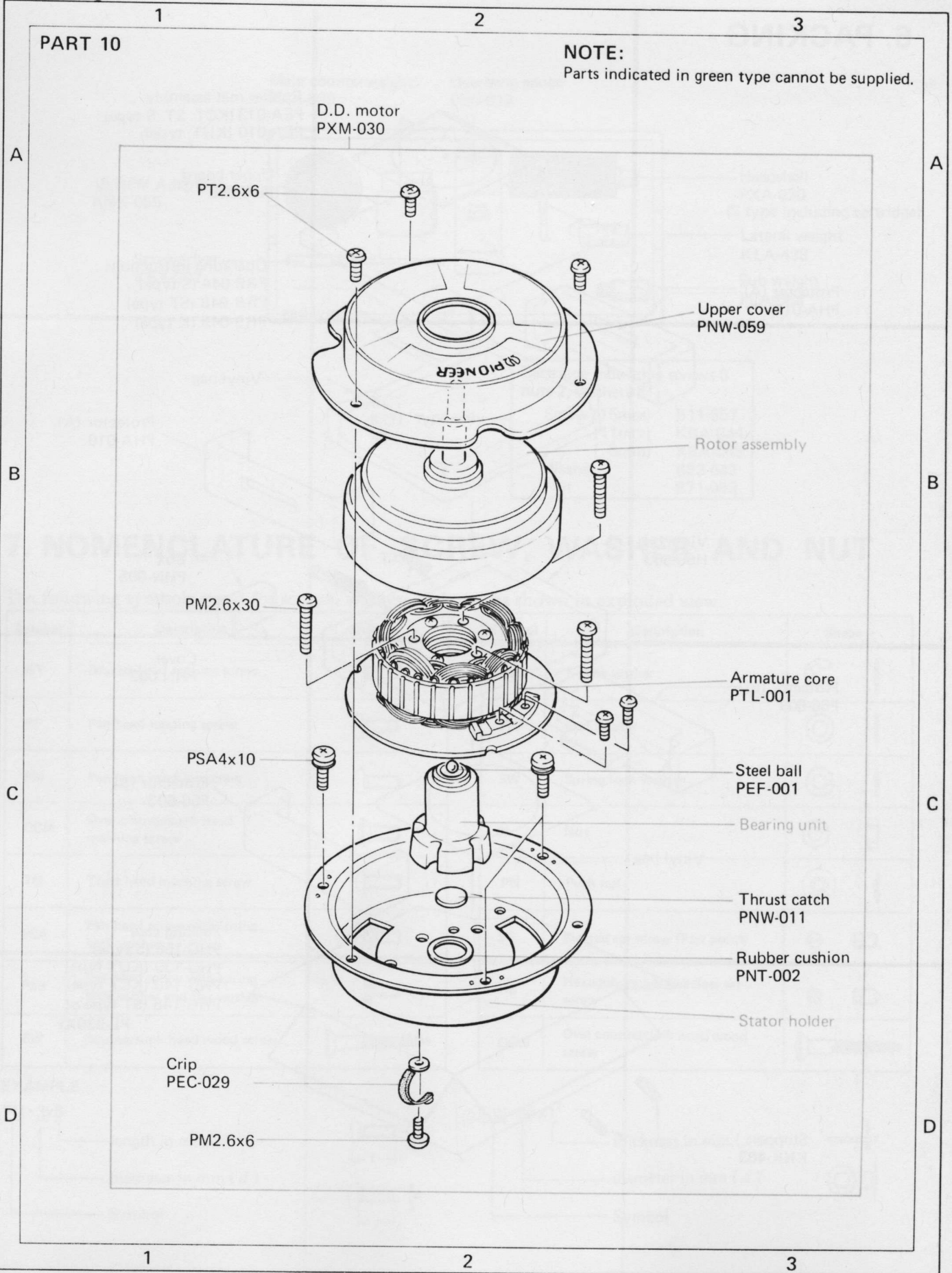

6. PACKING

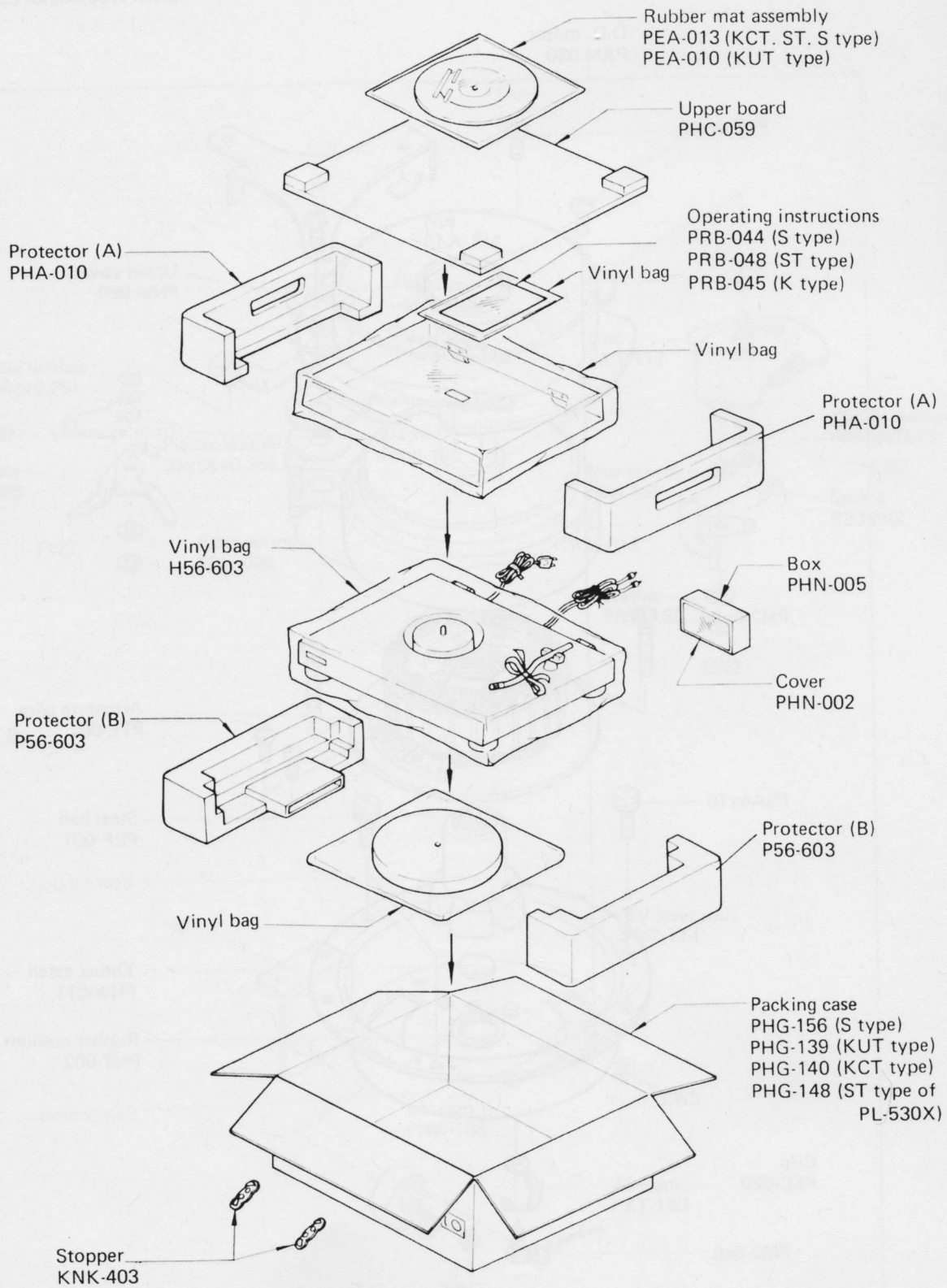

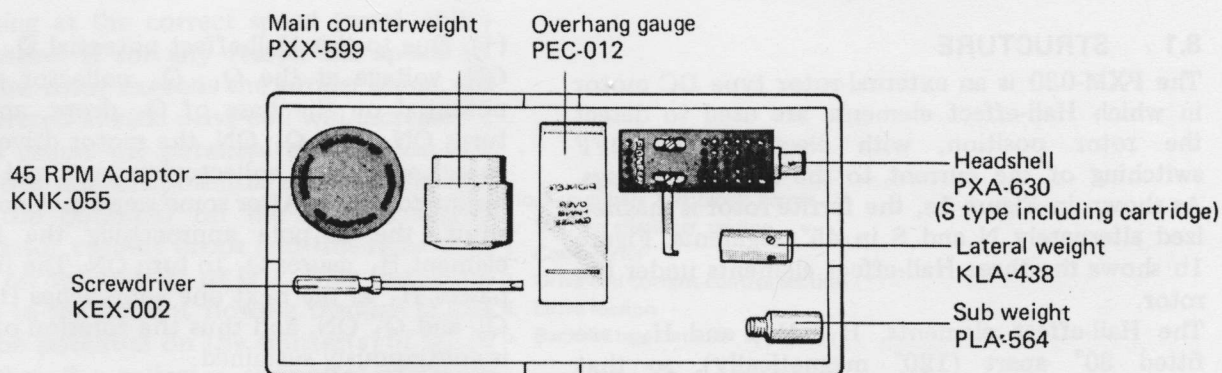

KCT KUT type only ST	Cartridge mounting screws-6 nuts-2, washers-2	
	Screw (15mm)	B11-657
	(11mm)	KBA-044
	(8mm)	KBA-045
	Washer	B23-642
	Nut	B71-053

7. NOMENCLATURE OF SCREW, WASHER AND NUT

The following symbols stand for screws, washers and nuts as shown in exploded view.

Symbol	Description	Shape
RT	Brazier head tapping screw	
PT	Pan head tapping screw	
PM	Pan head machine screw	
OCM	Oval countersunk head machine screw	
TM	Truss head machine screw	
PSA	Pan head screw with spring lock washer	
PSB	Pan head screw with spring lock washer and flat washer	
CW	Countersunk head wood screw	

Symbol	Description	Shape
EW	E type washer	
FW	Flat washer	
SW	Spring lock washer	
N	Nut	
PN	Push nut	
SF	Slotted set screw (Flat point)	
HS	Hexagon socket headless set screw	
OCW	Oval countersunk head wood screw	

EXAMPLE

PM • 3x8

length in mm (*l*)

diameter in mm (*d*)

Symbol

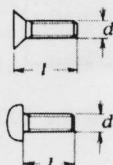

FW • 9φ x 1^t

thickness in mm (*t*)

diameter in mm (*d*)

Symbol

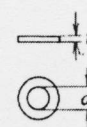

8. D.D. MOTOR(PXM-030) OUTLINE OF OPERATION

8.1 STRUCTURE

The PXM-030 is an external-rotor type DC motor in which Hall-effect elements are used to detect the rotor position, with electronic ON-OFF switching of the current to the motor windings. As shown in Figure 1a, the ferrite rotor is magnetized alternately N and S in 45° segments. Figure 1b shows the three Hall-effect elements under the rotor.

The Hall-effect elements, H_1 , H_2 , and H_3 , are fitted 30° apart (120° magnetically), so that whatever the orientation of the rotor, one of them will experience a Hall potential at a particular time.

8.2 OPERATION OF THE MOTOR (SEE CONNECTION DIAGRAM)

When the electrical supply is connected to the motor, current flows through the three Hall-effect elements, which go into the operating condition. If we assume, at this time, that a rotor S pole is located at the H_2 Hall-effect element position, then the Hall potential developed in H_2 sends the base of Q_5 negative (-) and that of Q_6 positive (+).

Due to this Hall-effect potential Q_1 , Q_6 turns ON, voltage at the Q_1 , Q_6 collector drops, the potential on the base of Q_7 drops, and Q_7 , Q_8 turns ON. With Q_8 ON, the motor drive coil W_3 is energized by the collector current, and the rotor begins to move. After some small movement of the rotor, the S pole approaching the Hall-effect element H_1 causes Q_2 to turn ON. The first N pole passes H_3 as the next one approaches H_1 , putting Q_6 and Q_7 ON, and thus the rotation of the rotor is continuously sustained.

On the other hand, when a N pole approaches the Hall-effect element(s) H_1 (H_2 , H_3), the polarity of the Hall potential changes, the base(s) of Q_5 go positive (+), the base(s) of Q_6 go negative (-), and so Q_1 , Q_6 turn OFF. This means that Q_7 , Q_8 also turn OFF and the current ceases to flow in the drive coil(s) W_3 (W_1 , W_2).

8.3 SPEED CONTROL

When no current is flowing through a drive coil (that is when a N pole is approaching the Hall-effect element), a voltage proportional to the speed of rotation of the rotor is induced in the drive coil (the same effect as with a generator). This voltage is rectified by the diode(s) D_1 (D_2 , D_3) and the positive potential derived is applied to the base of Q_{15} . Q_{16} and Q_{18} form a differential amplifier circuit, and the standard voltage for 33-1/3 or 45 rpm rotation is applied to the base of Q_{15} . It follows that so long as the rotor is

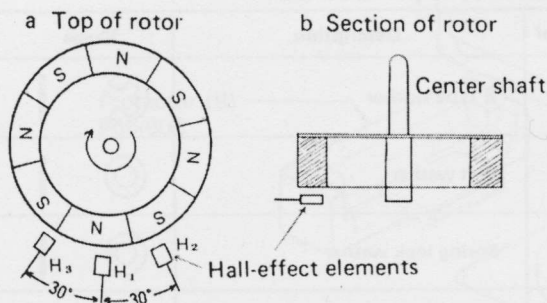

Fig. 1: Relative Locations of Rotor and Hall-Effect Elements

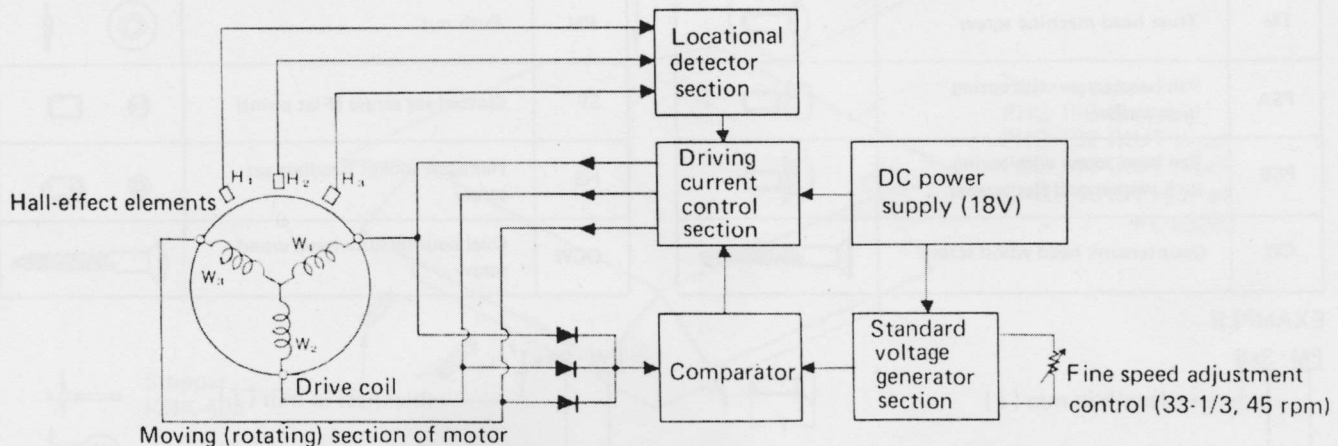

Fig. 2: Block Diagram of the PXM-020

turning at the correct speed (revs), this circuit is balanced. If for any reason the speed of rotation of the rotor exceeds the proper value, the voltage generated in each drive coil will increase.

This causes the potential on the base of Q_{15} , Q_{16} to rise, and the potential on the bases of Q_{14} rises. As the potential on the base of Q_{14} rises, the collector current drops and this reduces the potential on the base(s) of Q_{13} . This results in a reduction in the current flowing through Q_{13} , and a rise in the potential on the emitter(s) of Q_4 (Q_8 , Q_{12}), so that the collector current(s) of Q_4 (Q_8 , Q_{12}) drop. If the collector current drops, the field strength of the drive coil also drops, the rotor speed drops, and it returns to the correct speed of rotation.

On the other hand, if the rate of rotation of the rotor drops below its proper value, the process is precisely the reverse of the above: the voltage across each drive coil drops, and the base potential of Q_{15} drops. This causes the collector current of Q_{14} to increase, and the current(s) through Q_{13} also rise. As the collector current(s) of Q_{13} increase, the emitter potential(s) on Q_4 (Q_8 , Q_{12}) drop, the collector current(s) rise, the magnetic field strength of the drive coil(s) increases, and the rotor speed increases to the correct value.

8.4 TEMPERATURE COMPENSATION

The section which corrects the speed of rotation of the motor as the ambient temperature changes comprises varistors (D_4 , D_5 , D_6 , D_8 , D_9) to achieve temperature compensation.

- D_4 compensates Q_{17} . If D_4 were not provided, an increase in temperature would cause an increase in Q_{17} collector current, and a corresponding increase in Q_{16} , Q_{18} , Q_{14} , Q_{13} , with a rise in the base potential of Q_4 , Q_8 , and Q_{12} , and an increase in the speed of the motor.
- D_5 , D_6 provide the temperature compensation for rotor magnetism. Magnetic field strength drops at $-0.18\%/^{\circ}\text{C}$ with an increase in temperature. For this reason, if D_5 , D_6 are not provided, even at the proper rate of rotation, the voltage generated in the drive coils would drop, because the comparator would indicate that the speed has dropped, and so the motor speed would. D_5 (33-1/3) D_6 (45 rpm) raise the potential at the base of Q_{18} as the temperature rises, preserving the balance of Q_{16} and Q_{18} , and maintaining proper speed.

- D_8 and D_9 compensate D_7 and Q_{18} . D_7 (RD-9.1E) is a zener diode. The zener temperature coefficient is $0.06\%/^{\circ}\text{C}$. If D_8 and D_9 are not provided, as the temperature rises the zener potential will rise, so that the V_{B-E} of Q_{19} drops, dropping the emitter potential (the standard voltage) of Q_{19} . If the standard voltage rises, the speed of the motor also rises. This is the reason for the compensation by D_8 and D_9 for the rise in D_7 zener potential and the drop in V_{B-E} potential of Q_{19} . The temperature coefficient of D_9 (VD1222) is $-3.6\text{mV}/^{\circ}\text{C}$.

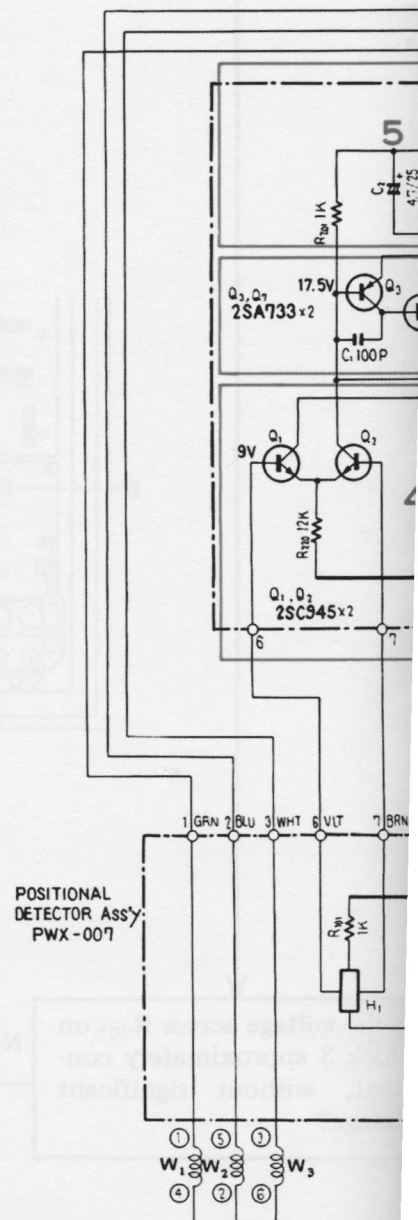

Block numbers and block names

1. Voltage stabilizer section
2. Comparator
3. Drive coil current control section
4. Drive section
5. Back voltage detector section

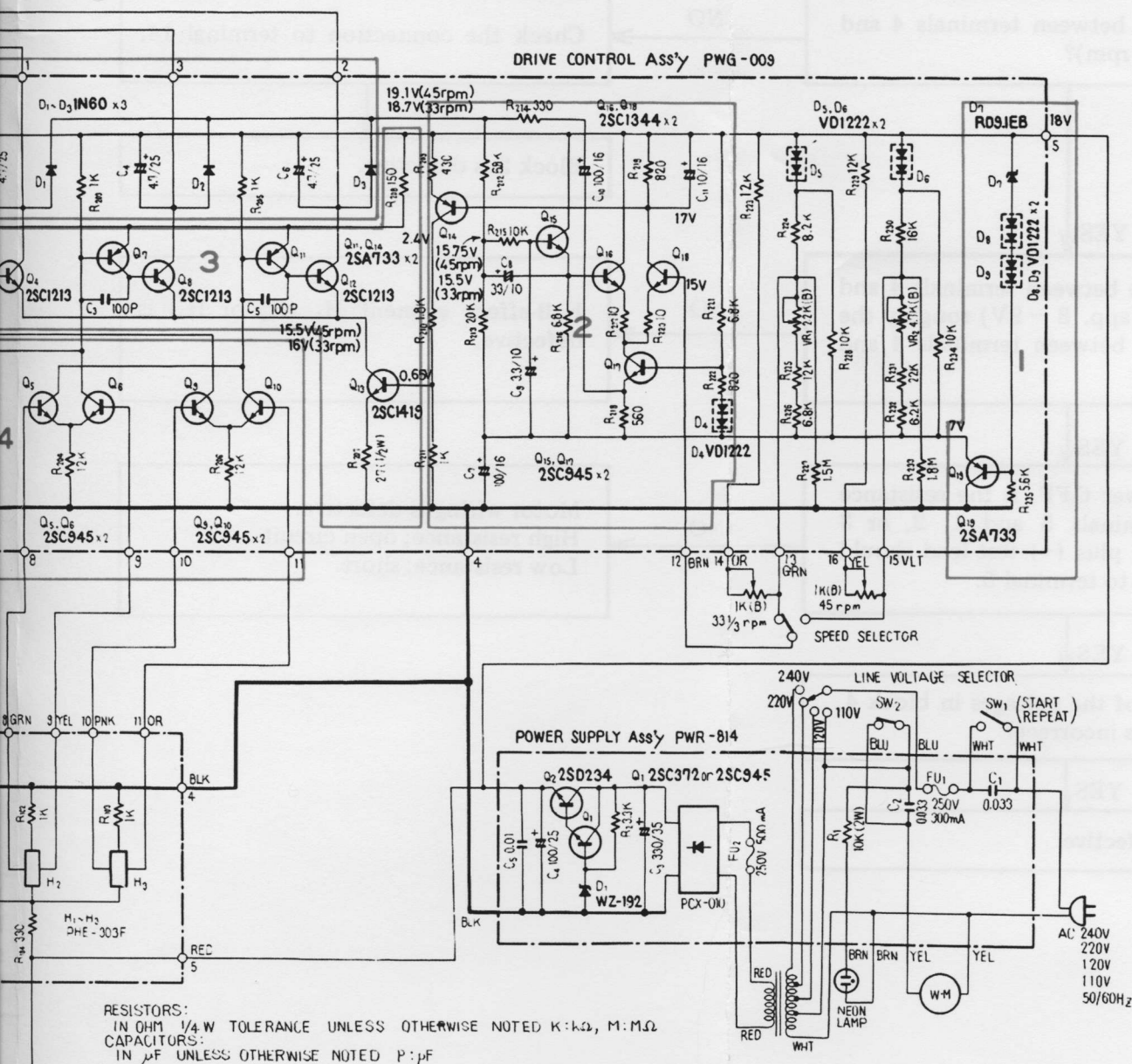

9. D.D. MOTOR TROUBLESHOOTING CHART

9.1 MOTOR DOES NOT TURN

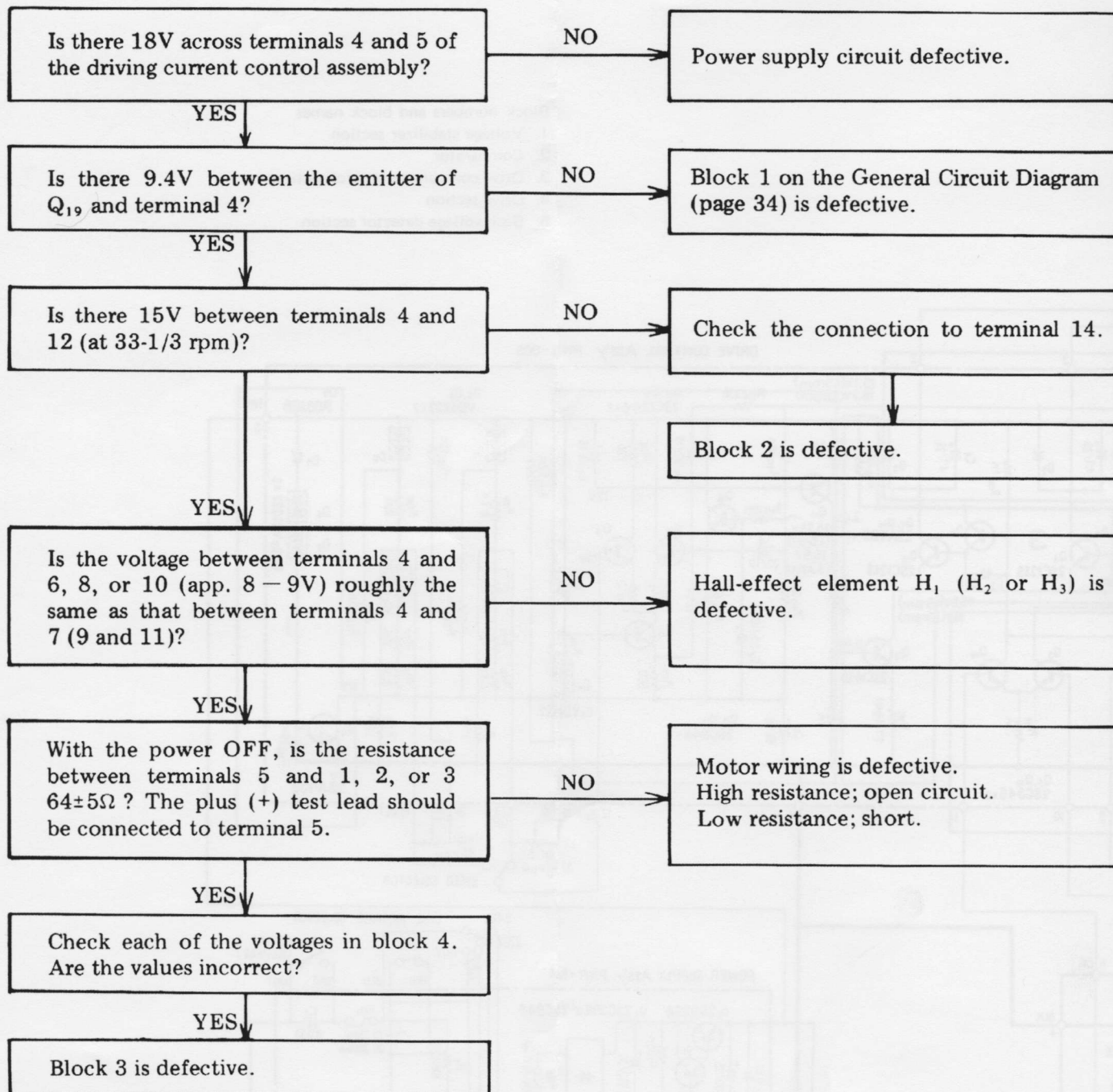

2 WIDE VARIATIONS IN MOTOR SPEED

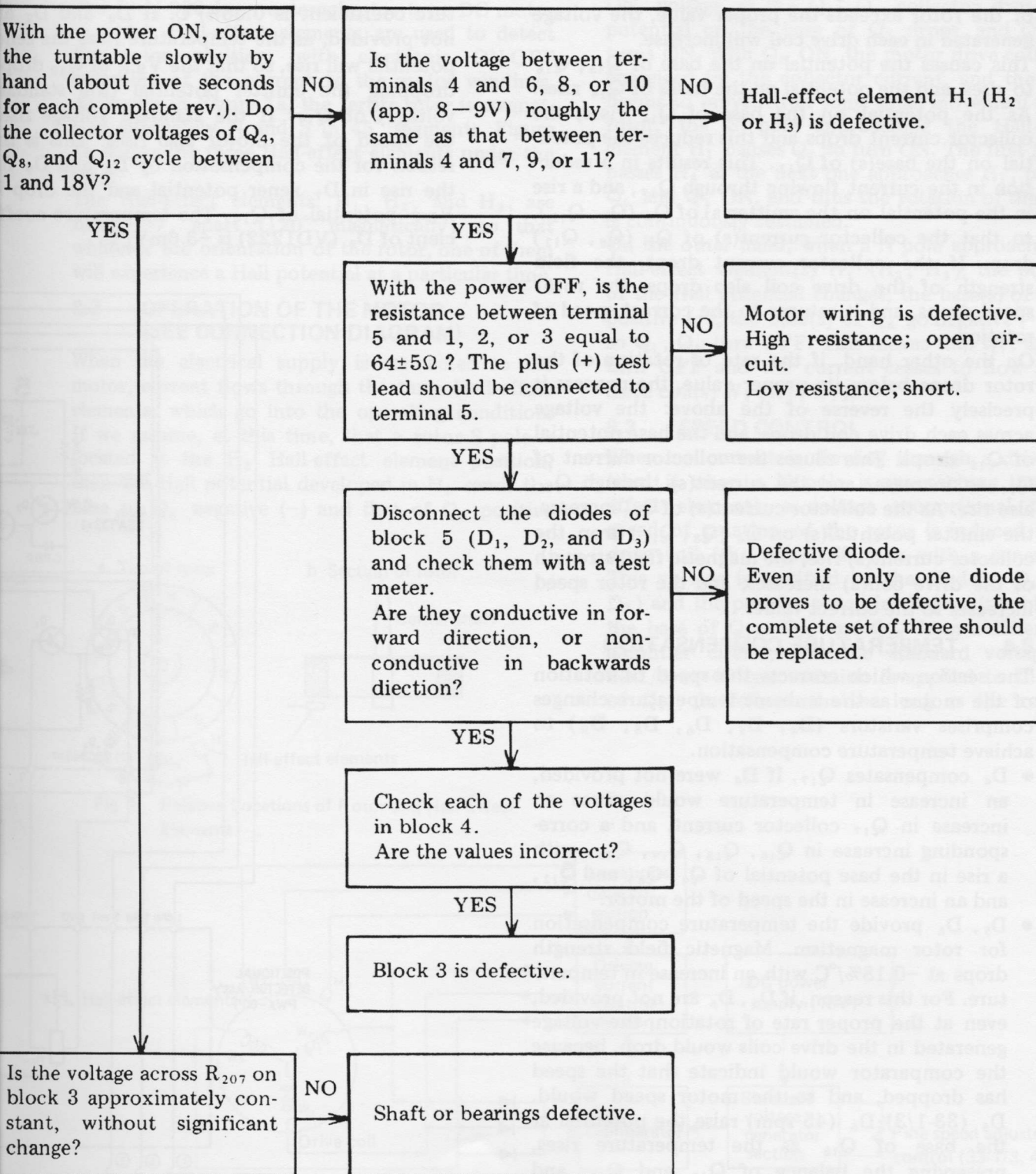

9.3 MOTOR RACES

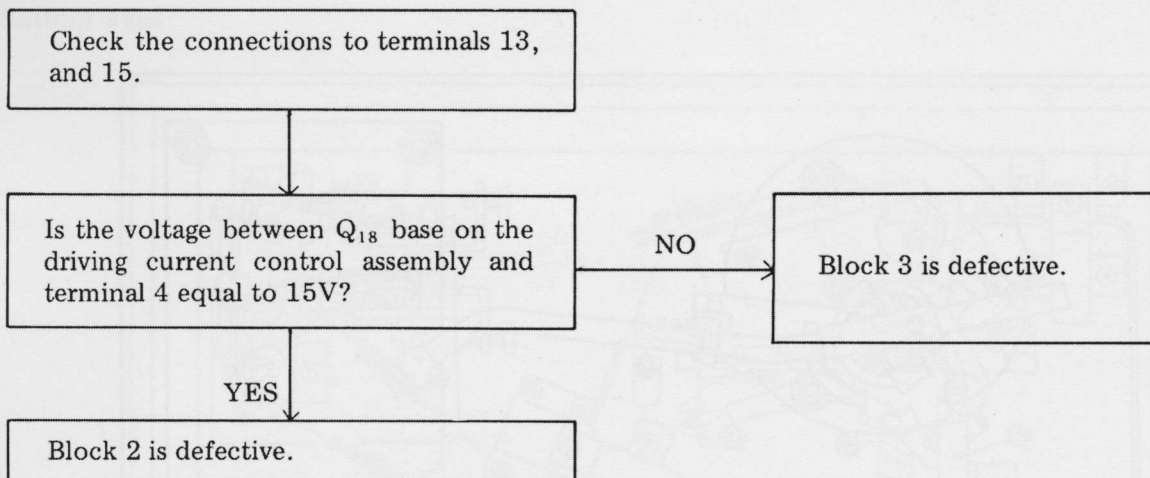

MOTOR SPEED ADJUSTMENTS

When it proves impossible to adjust the fine speed controls to give the correct speeds, the motor may be adjusted as follows.

1. Set the fine speed adjustment controls on the stereo turntable to their mechanical centers (approx. in the middle).
2. The separate volume-type controls on the P.C. Board PWG-009 are accessible for both 33 and 45 rpm adjustments. Use a small screwdriver to turn these preset controls to give synchronization as indicated by the stroboscopic speed indicator on the record player.
3. When even turning the controls fails to give the required adjustment, refer to Schematic diagram on page 12, and change R_{223} (33-1/3 rpm) and R_{229} (45 rpm) within the range 1.5k Ω to 5.6k Ω before repeating the adjustment.

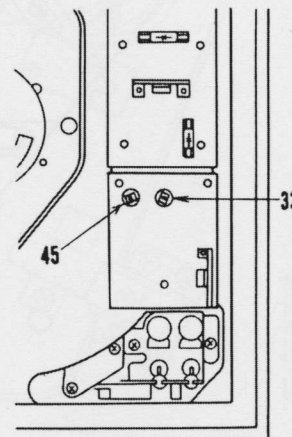

10. MECHANISM OPERATION

Upper View

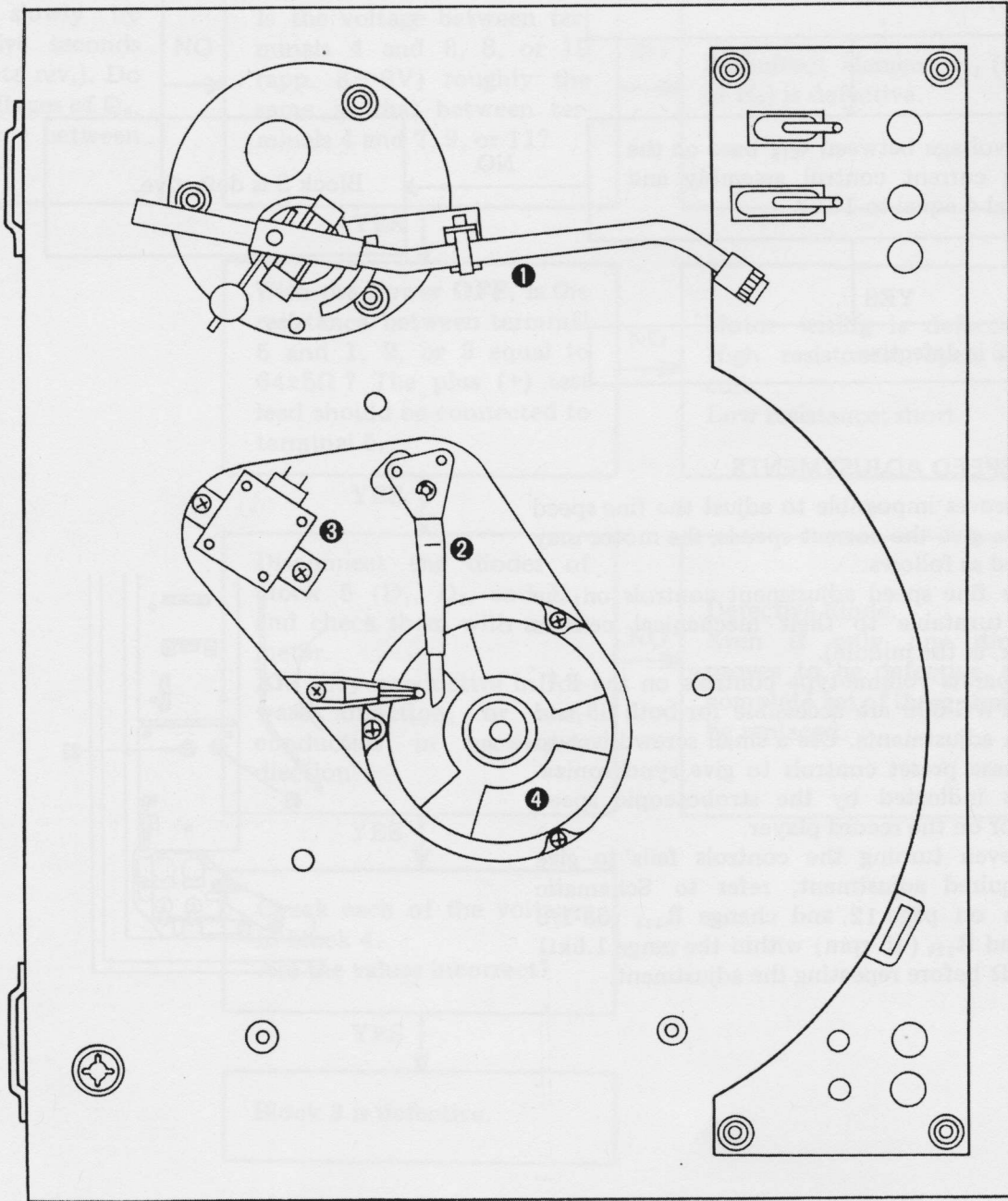

- ① Tone arm
- ② Plate H
- ③ Timing motor
- ④ D.D. motor

Bottom View

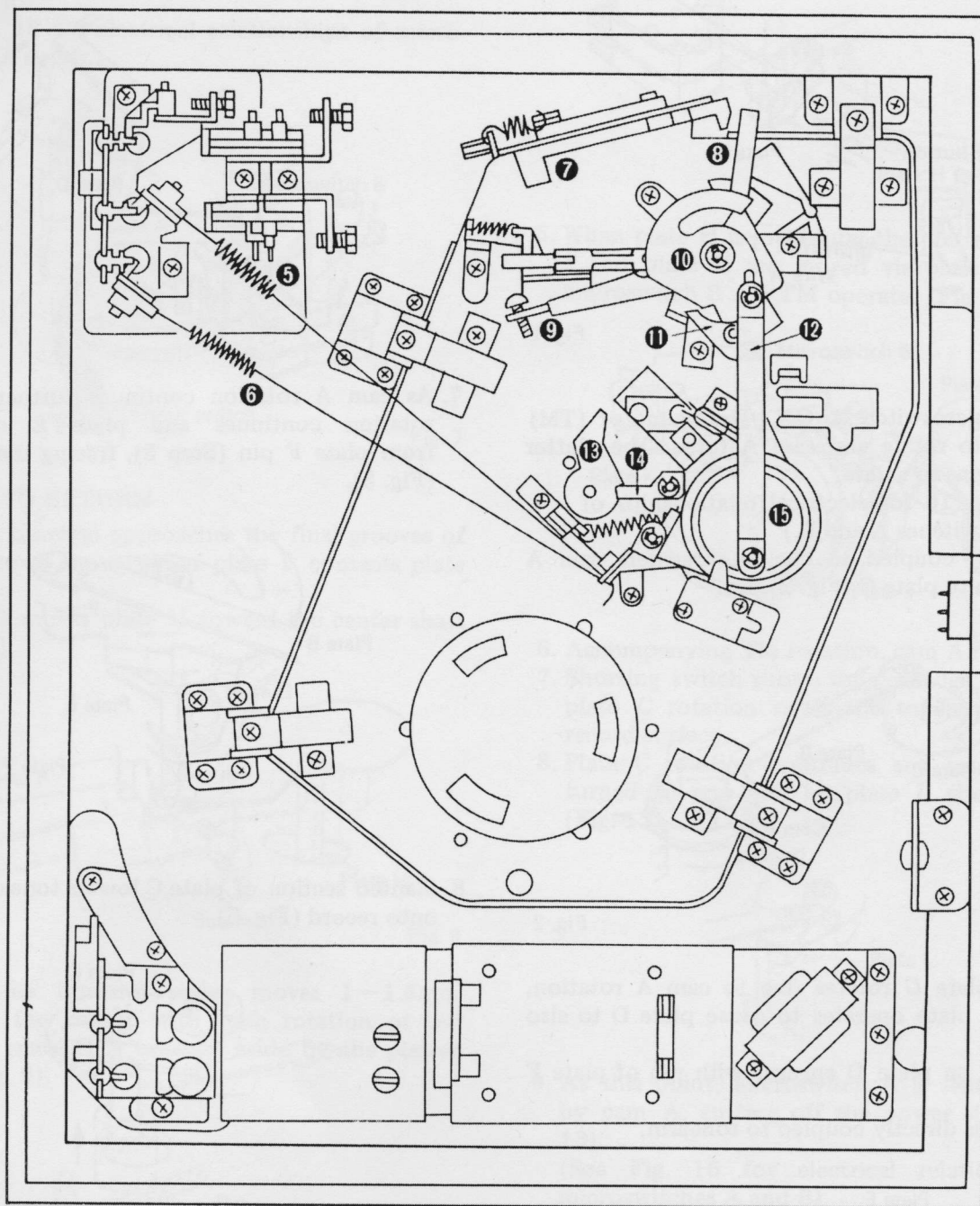

- | | | |
|-----------|-----------|-----------|
| ⑤ Wire C | ⑨ Plate F | ⑬ Plate G |
| ⑥ Wire A | ⑩ Plate C | ⑭ Plate J |
| ⑦ Plate M | ⑪ Plate E | ⑮ Cam A |
| ⑧ Plate D | ⑫ Plate B | |

10.1 AUTO LEAD-IN

1. When START button is pressed, wire A pulls plate A and sets microswitch A to ON (Fig. 1).

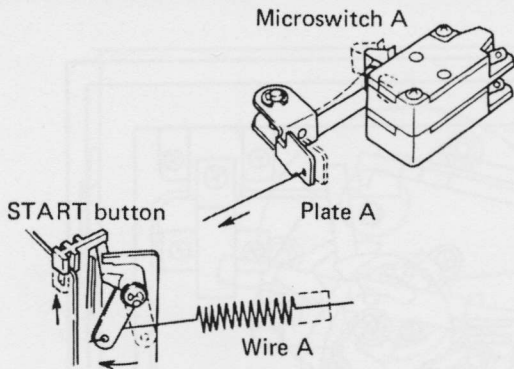

Fig. 1

6. Since cam A rotation continues, plate D moves tonearm to specified position and plate D stops (Fig. 4).

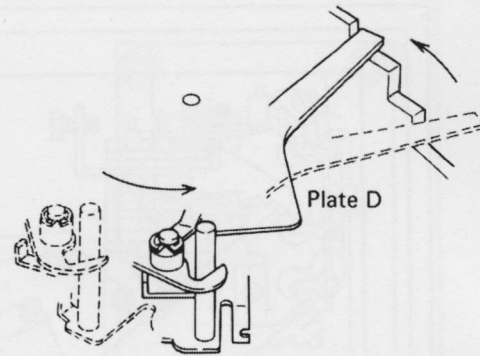

Fig. 4

2. With microswitch A ON, Timing-motor (TM) begins to rotate and cam A turns. The platter also begins to rotate.
(See Fig. 16 for electrical relationships of micro switches A and B.)

3. Plate B, coupled to cam A, transfers cam A rotation to plate C (Fig. 2).

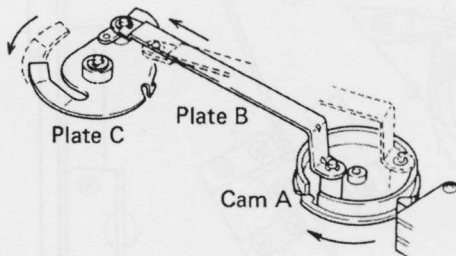

Fig. 2

7. As cam A rotation continues further, plate C rotation continues and plate E disengages from plate F pin (Step 5), freeing the tonearm (Fig. 5).

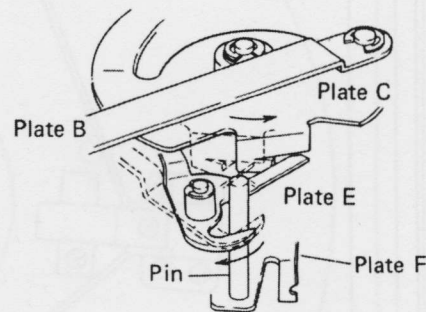

Fig. 5

4. When plate C rotates due to cam A rotation, friction plate operates to cause plate D to also rotate.

5. Plate E on plate D engages with pin of plate F (Fig. 3).

- Plate F is directly coupled to tonearm.

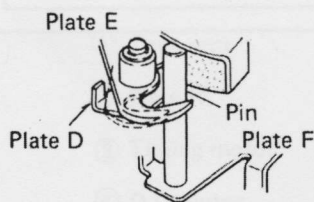

Fig. 3

8. Slanted section of plate C lowers tonearm stylus onto record (Fig. 6).

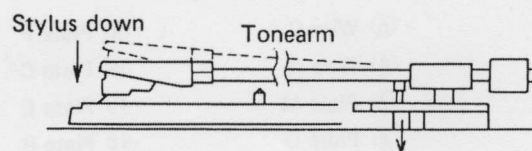
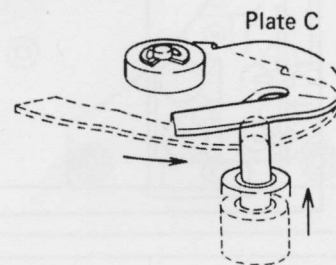

Fig. 6

9. At this point, cam A sets microswitch B to OFF and TM rotation stops. The cartridge output shorting switch opens at the same time (Fig. 7).

(See Fig. 16 for electrical relationships of microswitches A and B.)

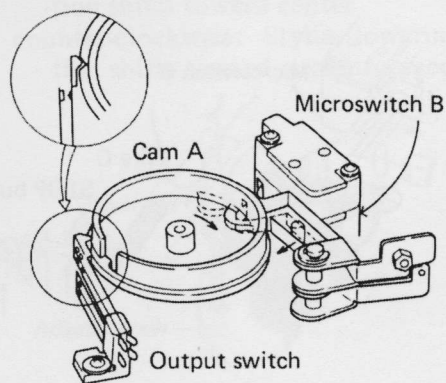

Fig. 7

10.2 AUTO RETURN

1. At the tonearm approaches the final grooves of the record, tip screw of plate F contacts plate G.
2. Plate G moves plate H toward the center shaft (Fig. 8).

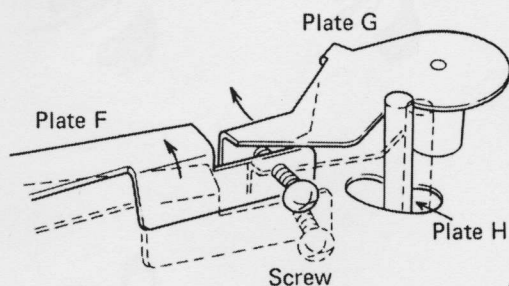

Fig. 8

3. While the tonearm stylus moves 1–1.5mm toward the center with each rotation of the record, plate H is brushed aside by the platter pin (Fig. 9).

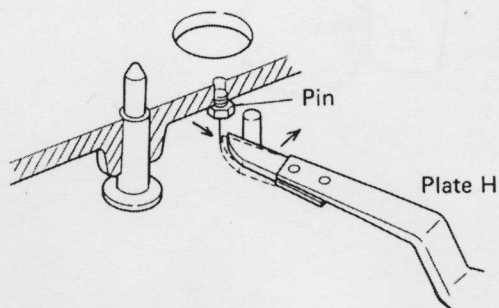

Fig. 9

4. When the stulus movement exceeds 3mm per record rotation, the platter pin engages plate H (Fig. 10).

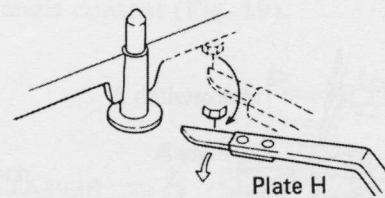

Fig. 10

5. When plate H is moved by the platter pin, plate J and plate K are moved via plate G, closing microswitch B and TM operates (Fig. 11).

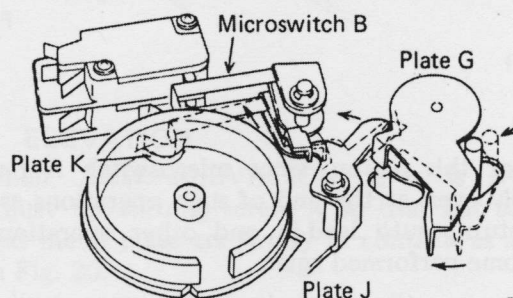

Fig. 11

6. Accompanying TM rotation, cam A rotates.
7. Shorting switch shorts the cartridge output and plate C rotation raises the tonearm from the record surface.
8. Plate C rotation continues and tonearm is returned to arm rest by plate L above plate C (Fig. 12).

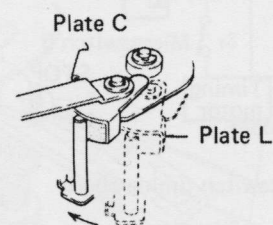

Fig. 12

9. At this point, microswitch A is switched OFF by cam A, cutting off the power supply (Fig. 13).

(See Fig. 16 for electrical relationships of microswitches A and B)

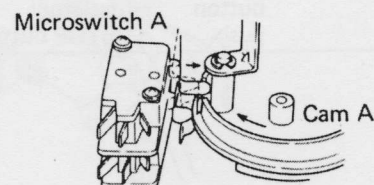

Fig. 13

10.3 AUTO REPEAT

1. When REPEAT button is locked, wire B pulls plate A, locking microswitch A in the ON position (Fig. 14).

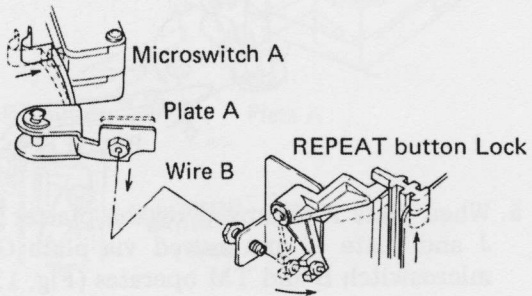

Fig. 14

2. For this reason, since microswitch A remains ON even at the end of such operations as auto return, auto lead-in and other operations become performed again.

10.4 AUTO STOP

1. When the STOP button is pressed during play, wire C pulls plate K, setting microswitch B to ON (Fig. 15).
Remaining steps are the same as steps 6 through 9 of Auto Return.

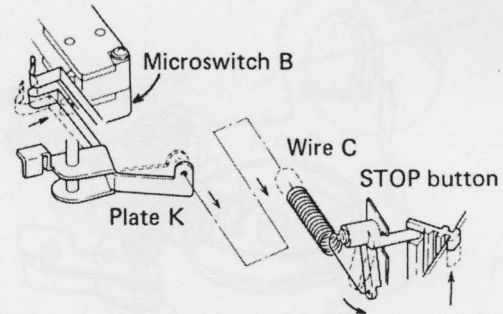

Fig. 15

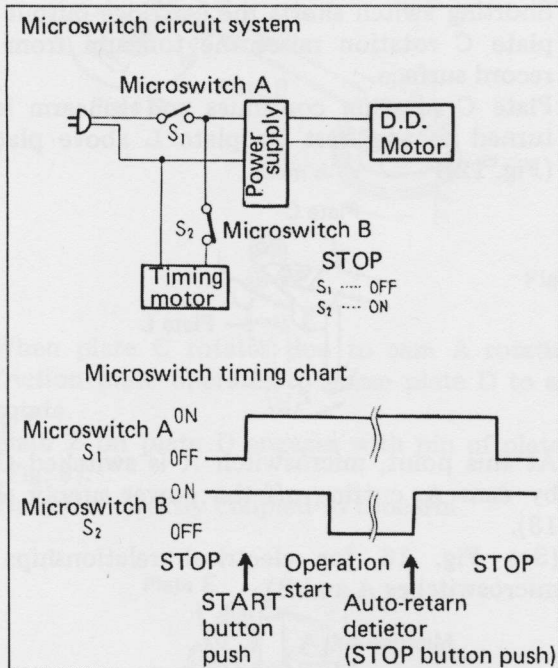

Fig. 16

11. ADJUSTMENTS

11.1 TONEARM LOWERING POSITION

Tonearm lowering position adjustment is performed by screw adjustment through panel hole (Figs. 17 & 18).

Turn clockwise: Stylus lowering position shifts toward center

Turn counter-clockwise: Stylus lowering position shifts toward circumference

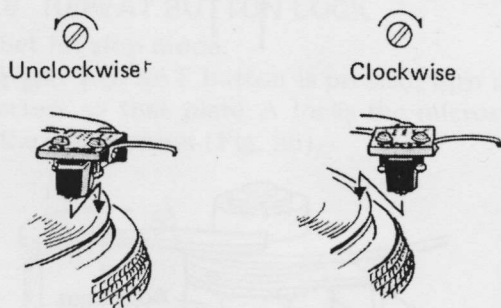
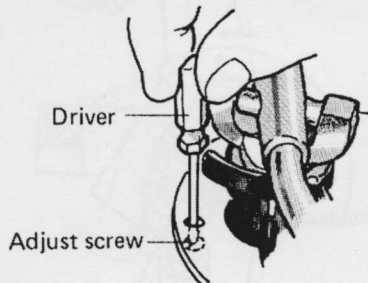

Fig. 17

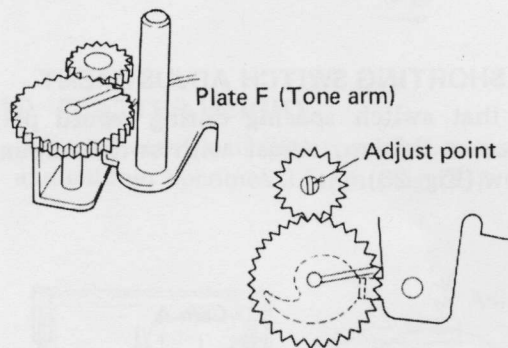

Fig. 18

11.2 IF TONEARM DOES NOT RETURN

1. Adjust stopper angle so that pin of plate L and stopper angle contact (Fig. 19).

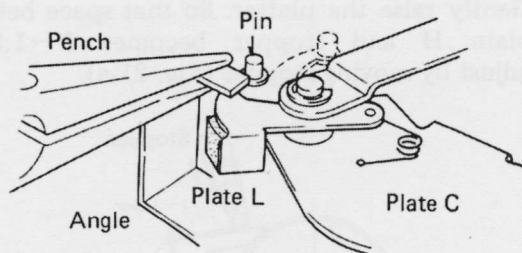

Fig. 19

11.3 ELEVATION

1. When ARM ELEVATION lever is DOWN, adjust by turning screw A so that flat section and metal plate are firmly in contact, as shown in Fig. 20.
2. Adjust screw B so that elevation movement amount becomes the same for both manual and automatic operation.
3. When elevation is UP, stylus and record surface separation shall be 10mm.
4. Elevation raising and lowering speed is adjusted by EV speed adjust screw.

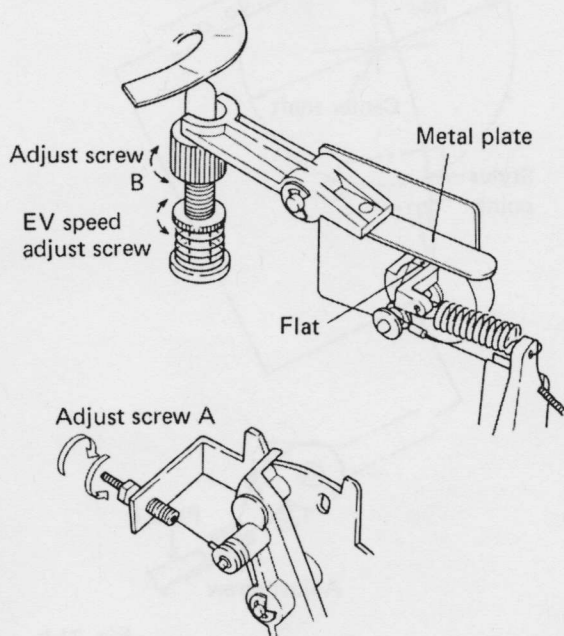

Fig. 20

11.4 AUTO RETURN STARTING POINT

- Stopper Pin Position Adjustment
- 1. With power ON, set for play mode.
- 2. In this mode, disconnect power cord from AC output.
- 3. Move tonearm once to center shaft, then return it to the arm rest.
- 4. Gently turn the platter in its reverse direction (1 turn).
- 5. Gently raise the platter. So that space between plate H and stopper becomes 1-1.5mm, adjust by moving stopper (Fig. 21-a).

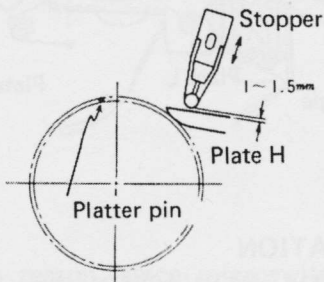

Fig. 21-a

11.5 DEFECTIVE TONEARM OPERATION

1. Measure plate D torque during auto return and lead-in operations.
2. Measuring position is 40mm from plate D center (rotation shaft). Turn adjusting nut so that torque at this time becomes 40 to 60g.

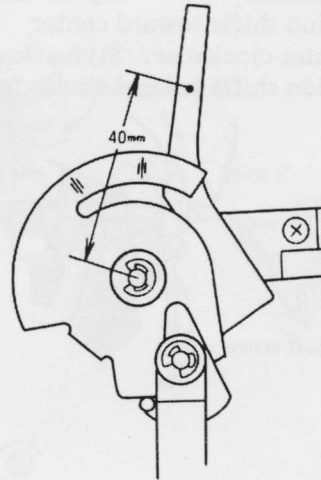

Fig. 22-a

- Auto Return Detection Position
- 1. Set mechanism for end of play condition.
- 2. With cartridge stylus 64mm from center shaft, so that tip screw of plate F and plate G contact, adjust tip screw (Fig. 21-b).

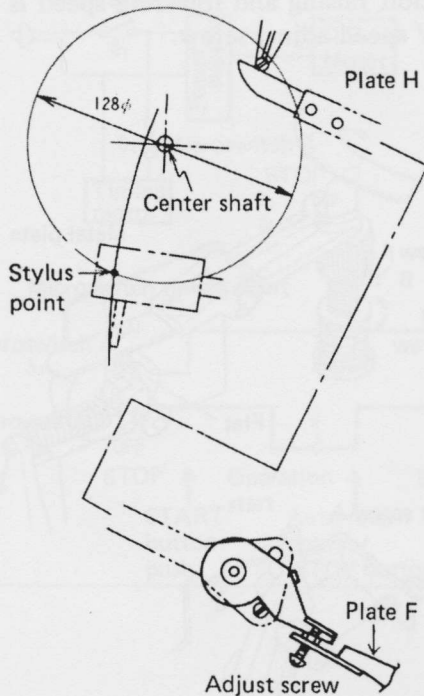

Fig. 21-b

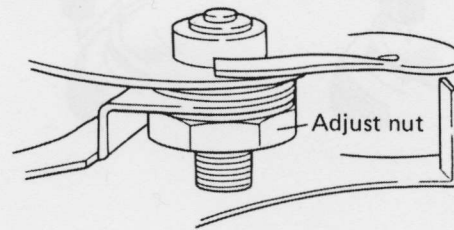

Fig. 22-b

11.6 SHORTING SWITCH ADJUSTMENT

So that switch spacing during record playing becomes 0.5mm, adjust with switch mounting screw (Fig. 23).

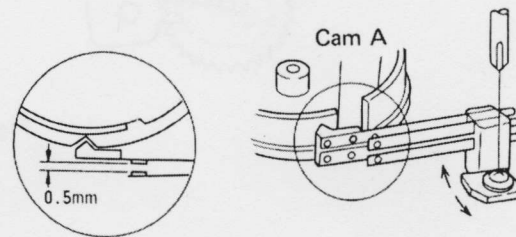

Fig. 23

11.7 TONEARM STOPPING POSITION

1. Set SIZE lever to 25 position.
2. At time of auto lead-in, when plate D has contacted plate M, turn adjusting screw so that dimension A shown in Fig. 24 becomes 2mm.

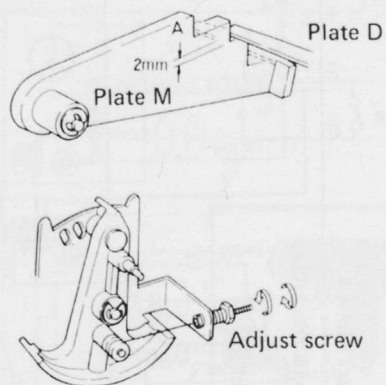

Fig. 24

11.8 REPEAT BUTTON LOCK

1. Set for stop mode.
2. When REPEAT button is pressed, turn adjusting screw so that plate A locks the microswitch in the ON position (Fig. 25).

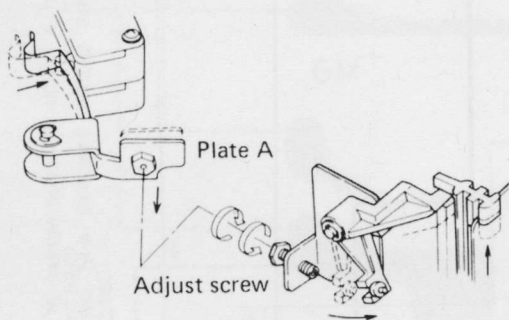

Fig. 25

11.9 PLATTER HEIGHT

1. Adjust 4 screws so that spacing between platter and cabinet becomes 2.5mm (Fig. 26).

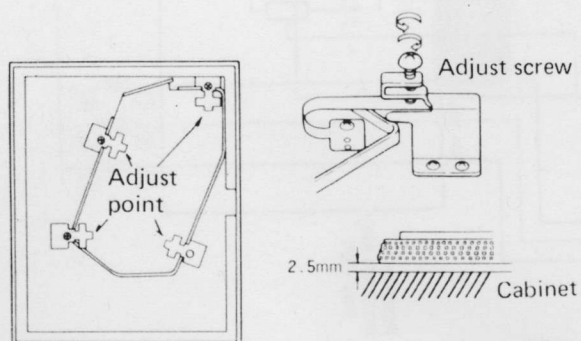
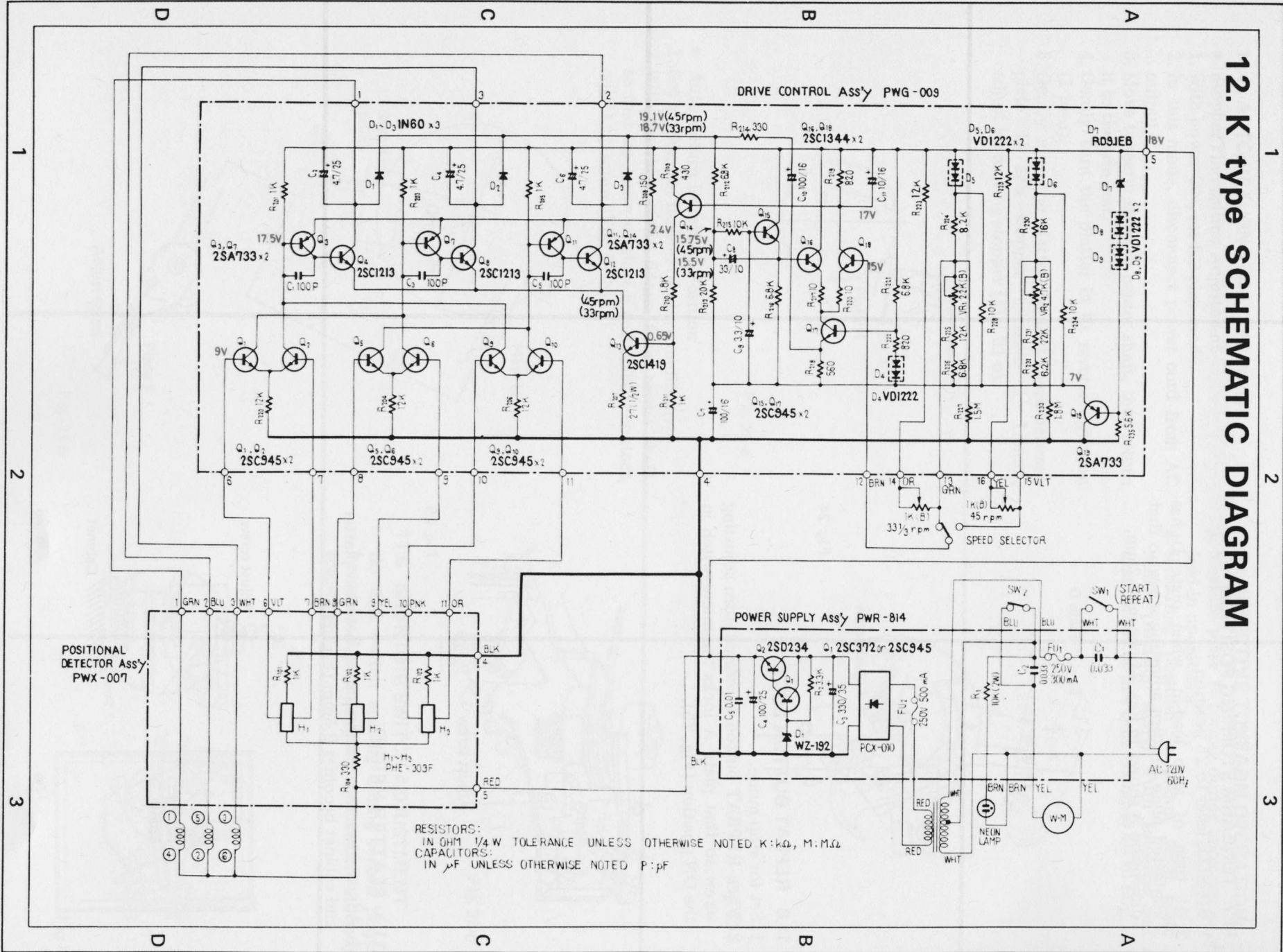
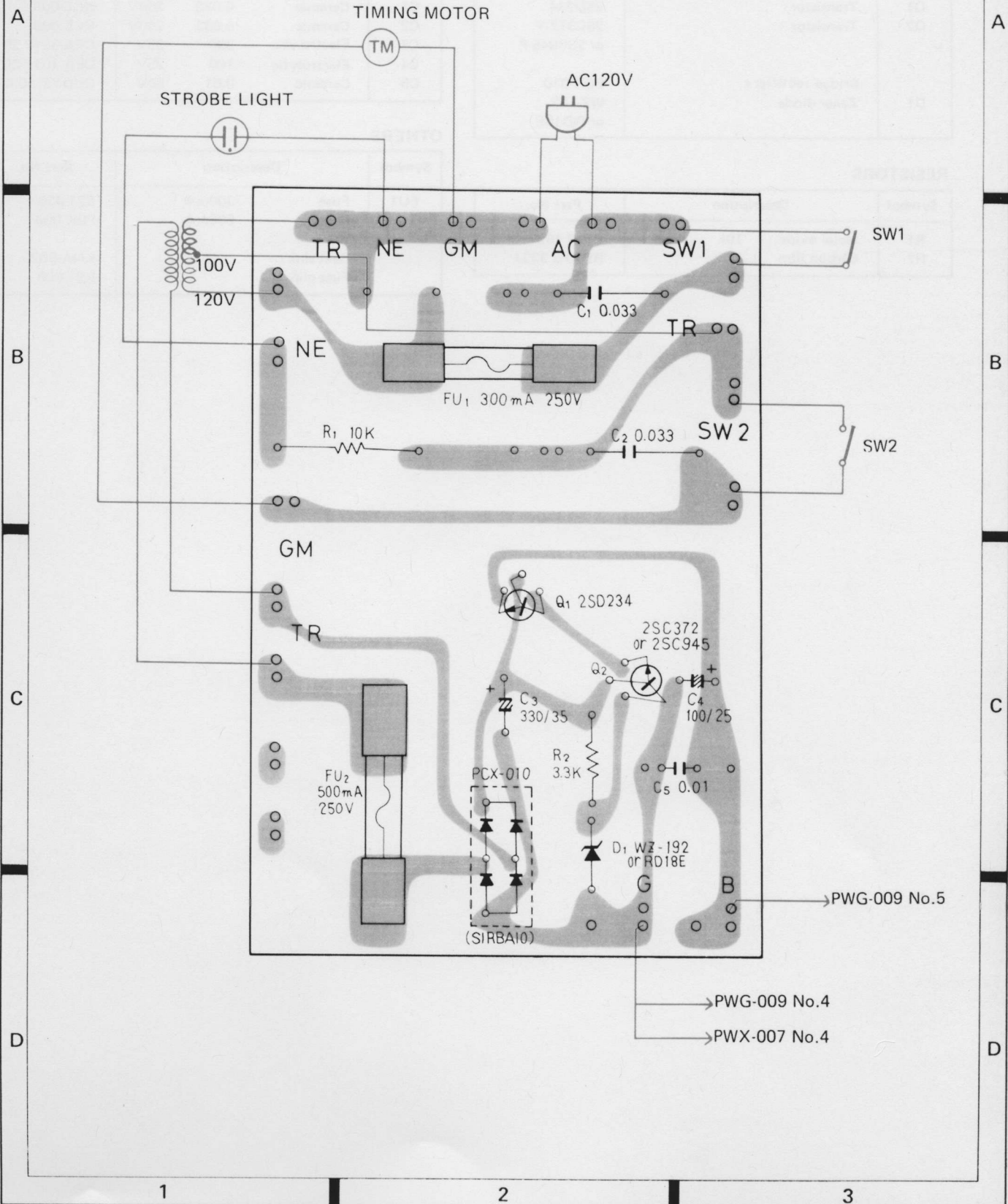

Fig. 26

12. K type SCHEMATIC DIAGRAM



13. K type POWER SUPPLY ASSEMBLY(PWR-820)



Parts List of Power supply assembly (PWR-820)

SEMICONDUCTORS

Symbol	Description	Part No.
Q1	Transistor	2SD234
Q2	Transistor	2SC372-Y or 2SC945-P
D1	Bridge rectifier s Zener diode	PCX-010 WZ-192 or RD18E

RESISTORS

Symbol	Description	Part No.
R1	Metal oxide 10k 2W	RS2P 103J
R2	Carbon film 3.3k	RD¼PS 332J

CAPACITORS

Symbol	Description	Part No.
C1	Ceramic 0.033 250V	KCE-009
C2	Ceramic 0.033 250V	KCE-009
C3	Electrolytic 330 35V	CEA 331P 35
C4	Electrolytic 100 25V	CEA 101P 25
C5	Ceramic 0.01 50V	CKDYF 103Z 50

OTHERS

Symbol	Description	Part No.
FU1	Fuse 300mA	E21-030
FU2	Fuse 500mA	PEK-004
	Heat sink	KNA-582
	Fuse clip	K91-006

PIONEER ELECTRONIC CORPORATION

4-1, Meguro 1-Chome, Meguro-ku, Tokyo 153, Japan

U.S. PIONEER ELECTRONICS CORPORATION

75 Oxford Drive, Moonachie, New Jersey 07074, U.S.A.

PIONEER ELECTRONIC (EUROPE) N.V.

Luthagen-Haven 9, 2030 Antwerp, Belgium

PIONEER ELECTRONICS AUSTRALIA PTY. LTD.

178-184 Boundary Road, Braeside, Victoria 3195, Australia