



Service Manual

Quartz PLL DIRECT DRIVE
STEREO TURNTABLE

PL-540

 **PIONEER®**

MODEL PL-540 COMES IN FIVE VERSIONS DISTINGUISHED AS FOLLOWS:

Type	Voltage	Remarks
KCT	120V only	Canada model (without cartridge)
KUT	120V only	U.S.A. model (without cartridge)
HGT	220V and 240V (switchable)	Europe or Oceania model (without cartridge)
ST	110V, 120V, 220V and 240V (switchable)	General export model (without cartridge)
S/G	110V, 120V, 220V and 240V (switchable)	U.S. Military model (within cartridge)

- This service manual is applicable to the PL-540/KUT, KCT. For servicing of the other types please refer to the additional service manuals.

CONTENTS

1. SPECIFICATION	3	7. EXPLODED VIEWS	
2. PANEL FACILITIES AND OPERATION	4	7.1 Cabinet	23
3. DISASSEMBLY	6	7.2 Tonearm	24
4. PARTS LOCATION	7	7.3 Bottom Plate	25
5. MECHANISM OPERATION AND ADJUSTMENT		7.4 D.D. Motor (PXM-061)	26
5.1 Start of Performance	8	7.5 Packing	27
5.2 Auto-return Detection	8	8. SCHEMATIC DIAGRAMS, P.C. BOARD	
5.3 Auto-return Operation	9	PATTERNS AND PARTS LIST	
5.4 Adjustment	9	8.1 Schematic Diagram	29
6. CIRCUIT DESCRIPTIONS		8.2 P.C. Board Connection Diagram	31
6.1 Block Diagram	11	8.3 Drive control Assembly (PWG-016)	33
6.2 Motor Operation	13	8.4 Oscillator Assembly (PWX-021)	34
6.3 Operation of the PD1003 IC (Oscillator Stage)	15	8.5 Power Supply Assembly (PWR-042 KUT) (PWR-040 KCT)	34
6.4 Operation of the PA2004 IC (Comparator Control)	15		
6.5 Operation of the PA2005 IC (Drive Control)	16		
6.6 Trouble Shooting Chart	20		
6.7 Motor Adjustments	22		

1. SPECIFICATION

Motor and Turntable

Drive System Direct-drive
 Motor Quartz PLL Hall motor
 Turntable Platter . . . 320mm diam. aluminum alloy die-cast
 Moment of Inertia 280kg·cm² (including platter mat)
 Speeds 33-1/3 and 45rpm
 Wow and Flutter Less than 0.025% (WRMS)
 Signal-to-Noise Ratio More than 73dB (DIN-B)
 (with Pioneer cartridge model PC-400)

Rotational Characteristics

Build-up Time Within 120° rotation at 33-1/3rpm
 Speed Deviation Less than 0.002%
 Speed vs. Load Characteristics Stable up to 150 grams
 drag load
 Speed Drift Less than 0.00008%/h at 33-1/3rpm
 Less than 0.00003%/degree temp. change at 33-1/3rpm

Tonearm

Type Static-balance type, S-shaped pipe arm
 Effective Arm Length 221mm
 Overhang 15.5mm
 Usable Cartridge Weight 4g (min.) to 10g (max.)

Subfunctions

Auto-return mechanism, Quick play mechanism,

Anti-skating force control

Stylus pressure direct-readout counter weight, Cueing device, Strobe light, Free stop hinges

Semiconductors

ICs 3
 Transistors 3
 Diodes 3
 Hall elements 3

Accessories

EP Adaptor 1
 Screwdriver 1
 Cartridge mounting screws 6
 Cartridge mounting nuts 2
 Cartridge mounting washers 2
 Operating instructions 1

Miscellaneous

Power Requirements AC 120V, 50, 60Hz
 Power Consumption 8W
 Dimensions 440(W) x 145(H) x 365(D) mm
 17-15/16(W) x 5-11/16(H) x 14-3/8(D) in.
 Weight 10kg/22lb

NOTE:

Specifications and design subject to possible modification without notice, due to improvements.

2. PANEL FACILITIES AND OPERATION

CONNECTIONS

The PL-540's phono cables and ground lead are attached to the rear panel of the turntable. The phono cable with the white plug is for the left channel and the one with the red plug is for the right channel. The thin wire with the Y-shaped connector at the end is the ground lead. This should be firmly connected to the ground terminal on the amplifier.

The way in which the phono cables are attached will depend on the type of cartridge used. Read the instructions in the booklet that comes with the cartridge as well as the operating instructions of the amplifier, and connect the phono cables properly.

Finally, plug the power cord into the AC outlet. Since the auto-return mechanism may be engaged by vibration during transportation, confirm its operation before play. Move the tonearm over to near the center shaft. The turntable platter begins to rotate and the tonearm returns to the arm rest. If the tonearm starts to move in the direction of the arm rest when moved manually, do not forcibly move it toward the center shaft.

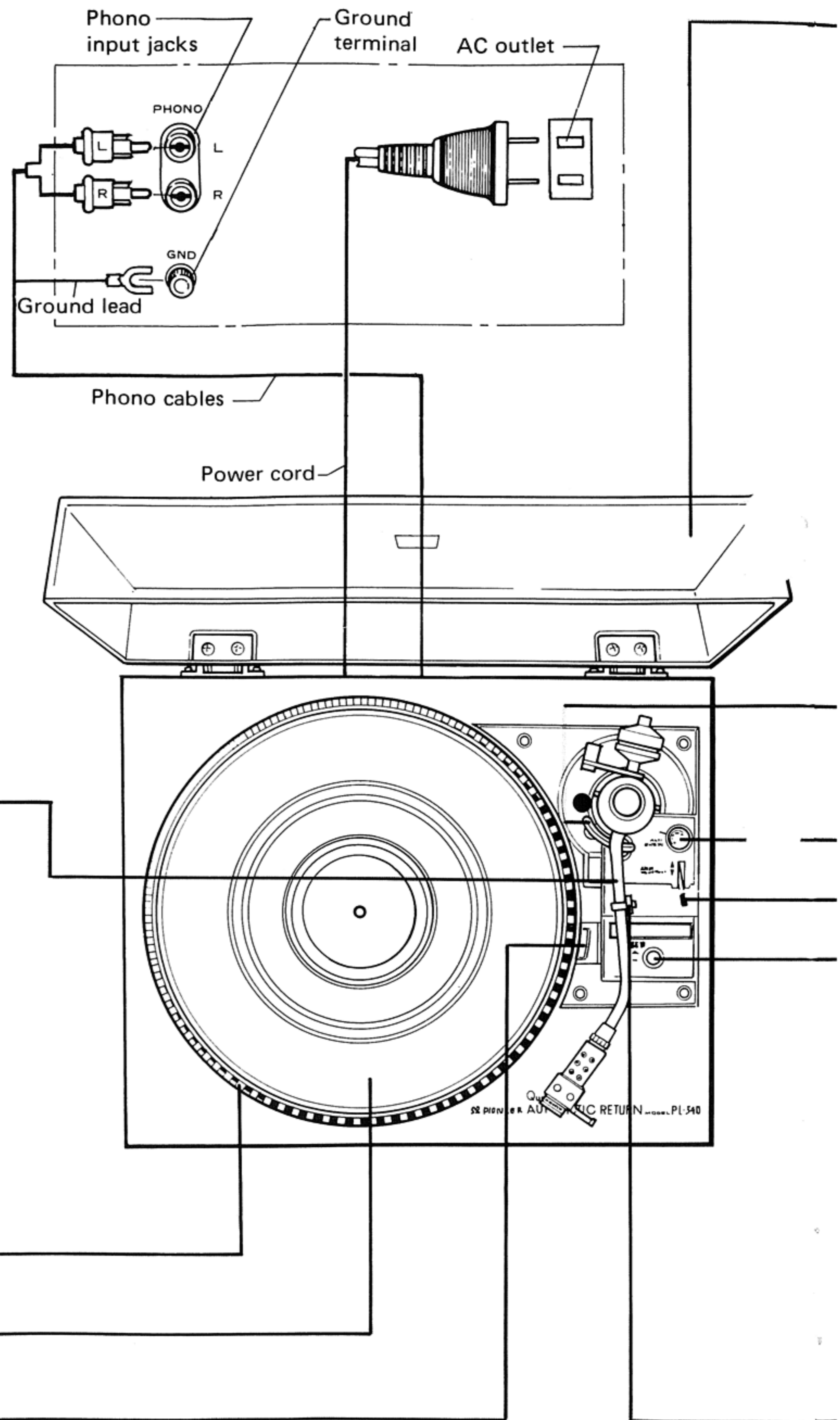

TONEARM

This tonearm is designed to apply the correct tracking force to the cartridge and to keep this force at the precise level for faithful tracking of the record grooves. It also has the job of switching the power on to the turntable.

- When the tonearm is moved from the arm rest to the platter, the power comes on, the strobe lamp lights up, and the platter rotates.
- When the tonearm is returned to the arm rest, the power to the turntable is cut off, the strobe light goes off, and the platter stops rotating.

PLATTER/STROBOSCOPE

When the tonearm is moved and power is supplied to the turntable, the platter will start rotating at the set rotation speed.

When the turntable reaches its rated speed, the markings around the side of the platter which constitute the stroboscope and which are illuminated by the strobe light appear to stand still, indicating that the rated speed has been reached.

PLATTER MAT

This platter mat stabilizes the records and also absorbs external vibration.

STROBE LIGHT

This light comes on when the tonearm moves away from the arm rest toward the platter. It irradiates the stroboscope around the outside of the platter.

EP ADAPTOR

Place this over the center shaft when you want to play a record which has a large EP-type center hole.

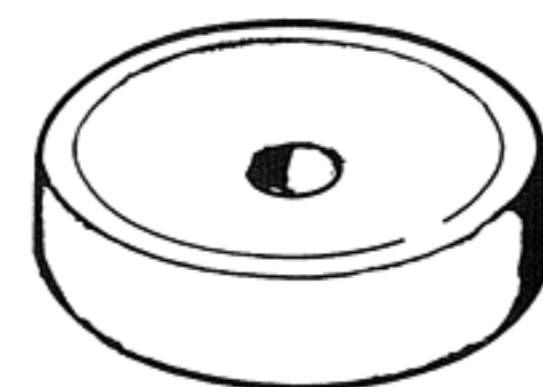

DUST COVER

Keep this closed unless operating the controls or tonearm, or changing over records. This serves to keep dust from adhering to the records during record play. When fully opened and pulled straight up, this dust cover can be removed from the cabinet.

ARM-ELEVATION

When the ARM-ELEVATION lever is operated, this will move up or down. Its oil-damped mechanism and spring ensure that the tonearm is raised and lowered smoothly.

ANTI-SKATE KNOB

This knob is used to cancel out the harmful skating force which is generated during record play. For further details, see "ANTI-SKATING ADJUSTMENT."

ARM-ELEVATION LEVER

UP (▲): When this lever is set to this position, the tonearm will rise. Set it to UP before record play and when you want to stop record play while a track is being played or when you want to change over to a different track.

DOWN (▼): When the lever is set to this position, the tonearm will be lowered. If it is set to DOWN for record play the tonearm will be lowered onto the surface of the record, and play will begin.

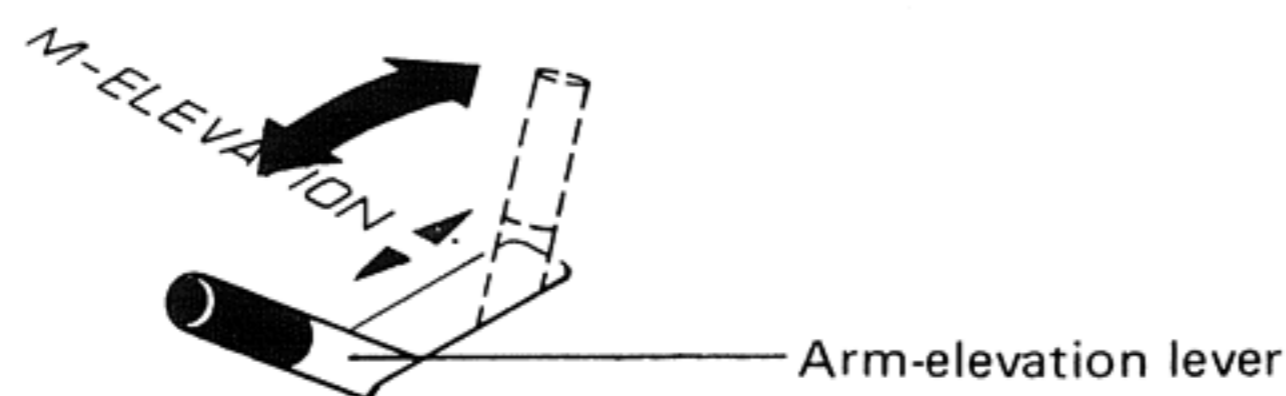

SPEED SELECT SWITCH

45 When this switch is depressed, the platter will rotate at 45rpm. Depress for playing 45rpm records, singles or EP's.

33 When this switch is set to the released position, the platter will rotate at 33rpm. Release for playing 33-1/3rpm records like LP's.

ARM REST

The arm rest supports the tonearm. As illustrated in the figure, use the clamp to keep the tonearm in place when you are not playing records.

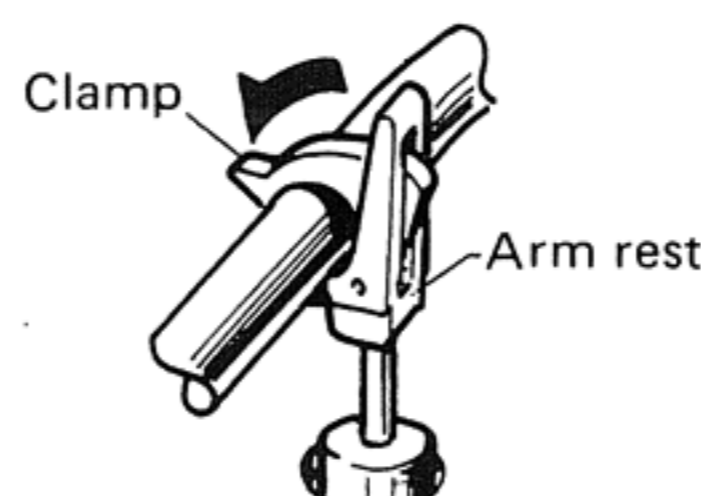

OPERATION

1. Place the record to be played on the platter.
2. Set the SPEED select switch to the speed at which the record is to be played.
3. Set the ARM-ELEVATION lever to the UP ▲ position.
4. Remove the stylus cover and release the arm clamp.
5. Hold the headshell by the finger lift and move the stylus across the record to the track you want played. The platter will begin to rotate.
6. Set the ARM-ELEVATION lever to the DOWN ▼ position.
The stylus will descend slowly to the record and play will begin.
7. Adjust the volume and tone controls on the amplifier to the preferred levels, and then sit back and enjoy your record.
8. After the record has been played, the auto-return mechanism is actuated and the tonearm returns to the arm rest. At the same time, the platter stops rotating and the power to the turntable is turned off.
9. Secure the tonearm to the arm rest with the clamp and attach the stylus cover to protect the stylus.

OPERATION PRECAUTIONS

- Be careful not to make the turntable vibrate while a record is playing, since this can result in damage to the stylus and record.
- Place only one record at a time on the platter. If two or more records are stacked on the platter, the stylus will not make proper contact with the grooves, and this will impair the quality of reproduction.
- Do not disconnect the power cord while the stylus is still in a record groove as this may result in damage to the stylus and record.
- Never obstruct the turntable with the hand while it is rotating. This may cause damage.
- Do not force the tonearm closer than 40mm to the center shaft or away from the arm rest. If this distance is exceeded, you may damage the internal mechanisms and render automatic operation ineffective.

3. DISASSEMBLY

1. TURNTABLE DISASSEMBLY PROCEDURES

Control Panel

Disassemble each part in the following order.

1. After removing the turntable platter, undo the 5 wood screws, and take off the cover.
2. Undo the 4 hexagonal wood screws.

3. Undo the mechanical base mounting screw.
4. Disconnect the PU cord connector.
5. Unscrew the control panel from the mechanical base.
6. Undo the push-type switch.
7. Disconnect the neon lamp tube.
8. Undo the lamp holder.

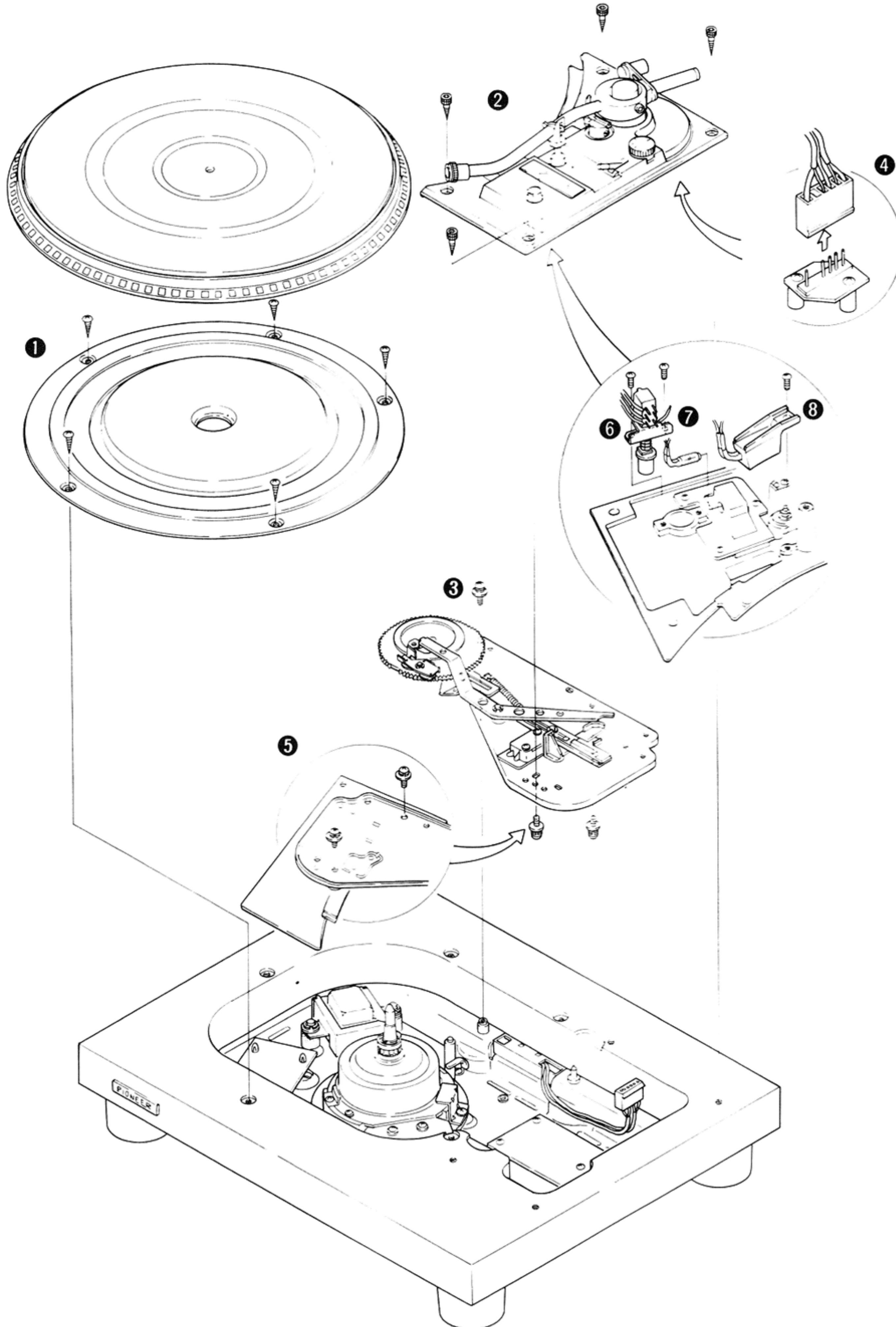

Tonearm

1. Undo 2 screws from the PU base plate.
2. Disconnect the PU leads from the PU base plate.
3. Loosen the PU plate screws, and then remove PU plates A and B from the arm assembly.
4. Loosen the hexagonal screw securing the tonearm to the stand base, and then remove the arm.

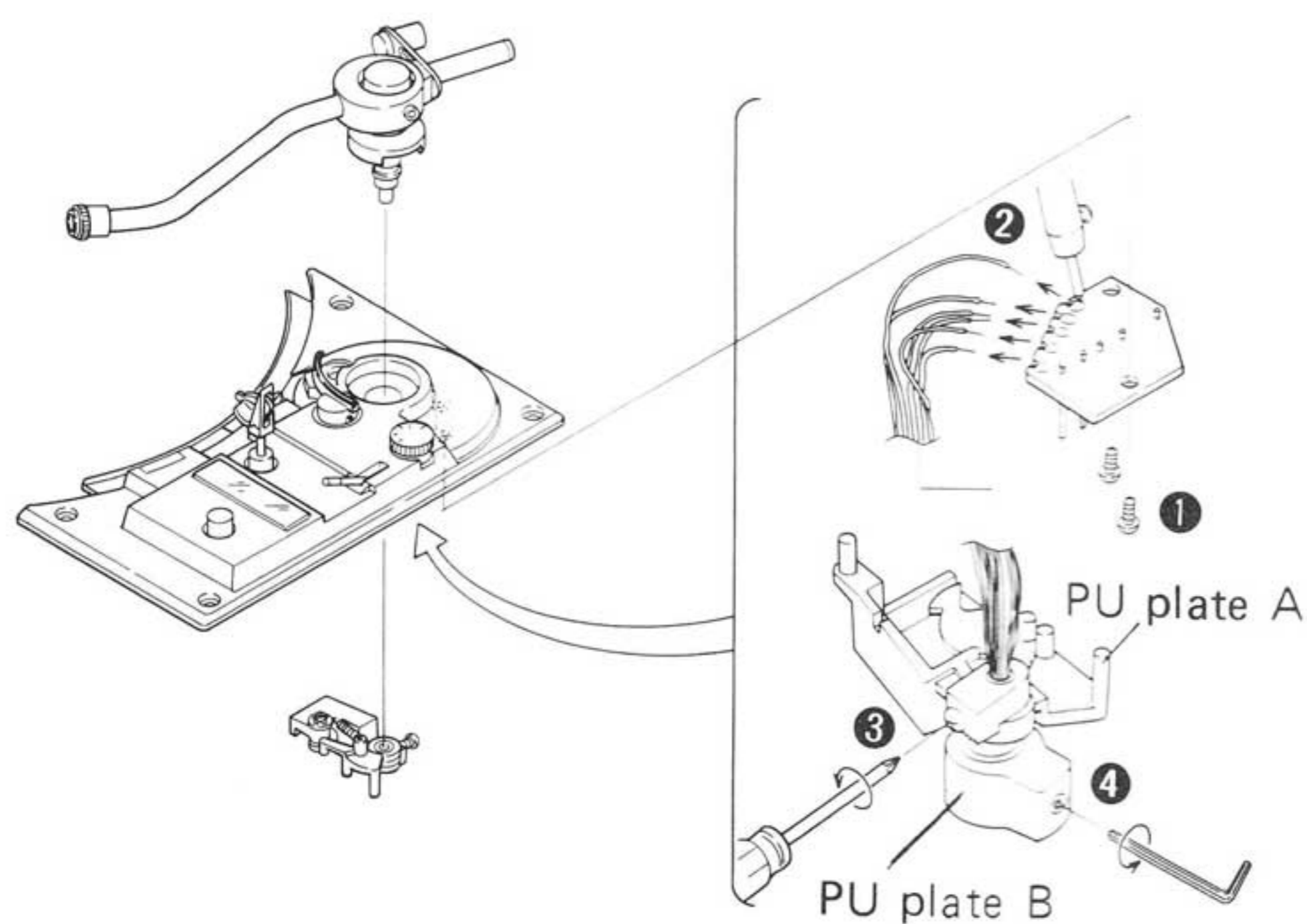

D.D Motor

- If the motor is to be removed, only remove it after the control panel has been removed.
1. Disconnect all leads connected to the D.D motor printed circuit board.
 2. Undo the motor mounting screws.

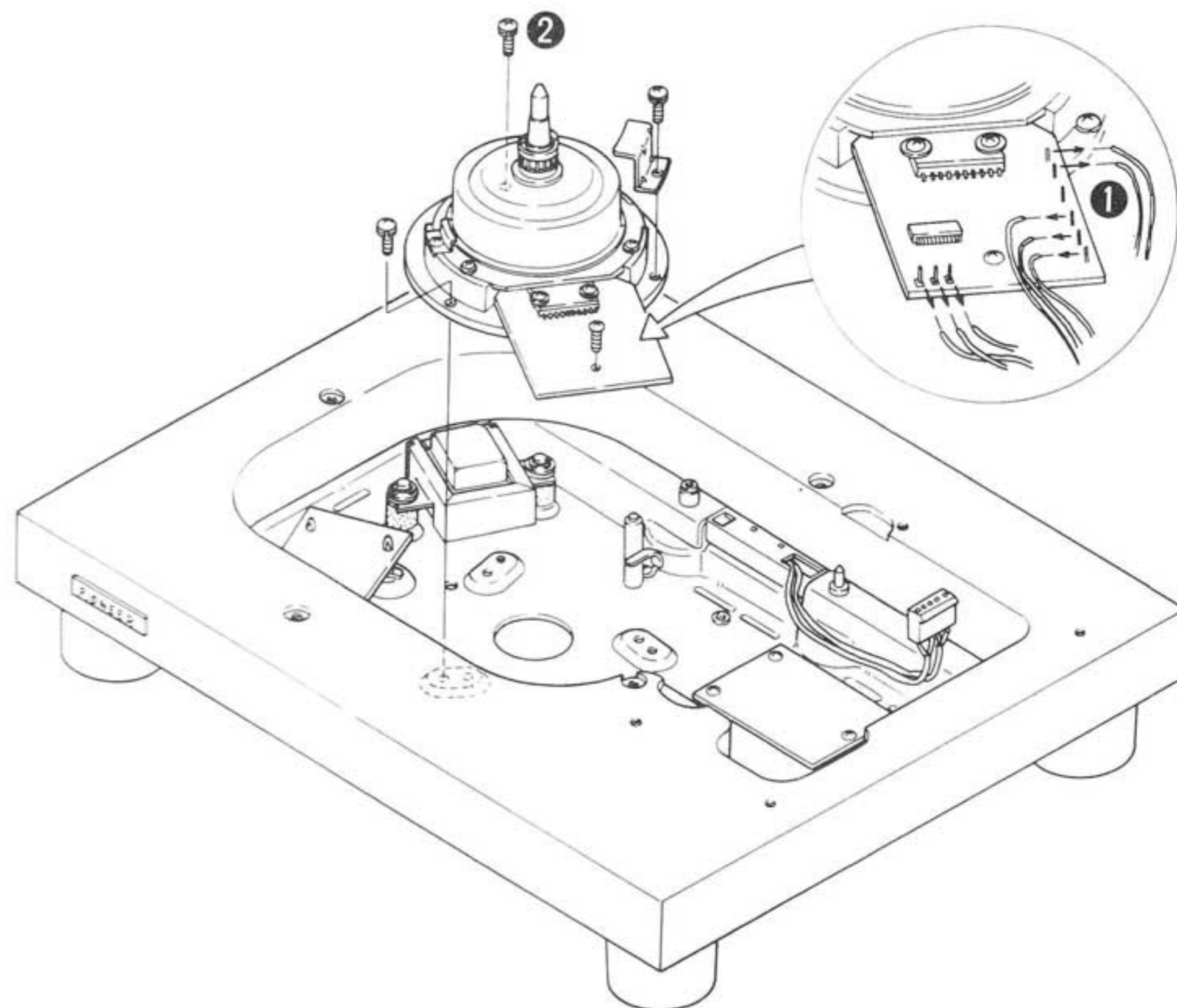

4. PARTS LOCATION

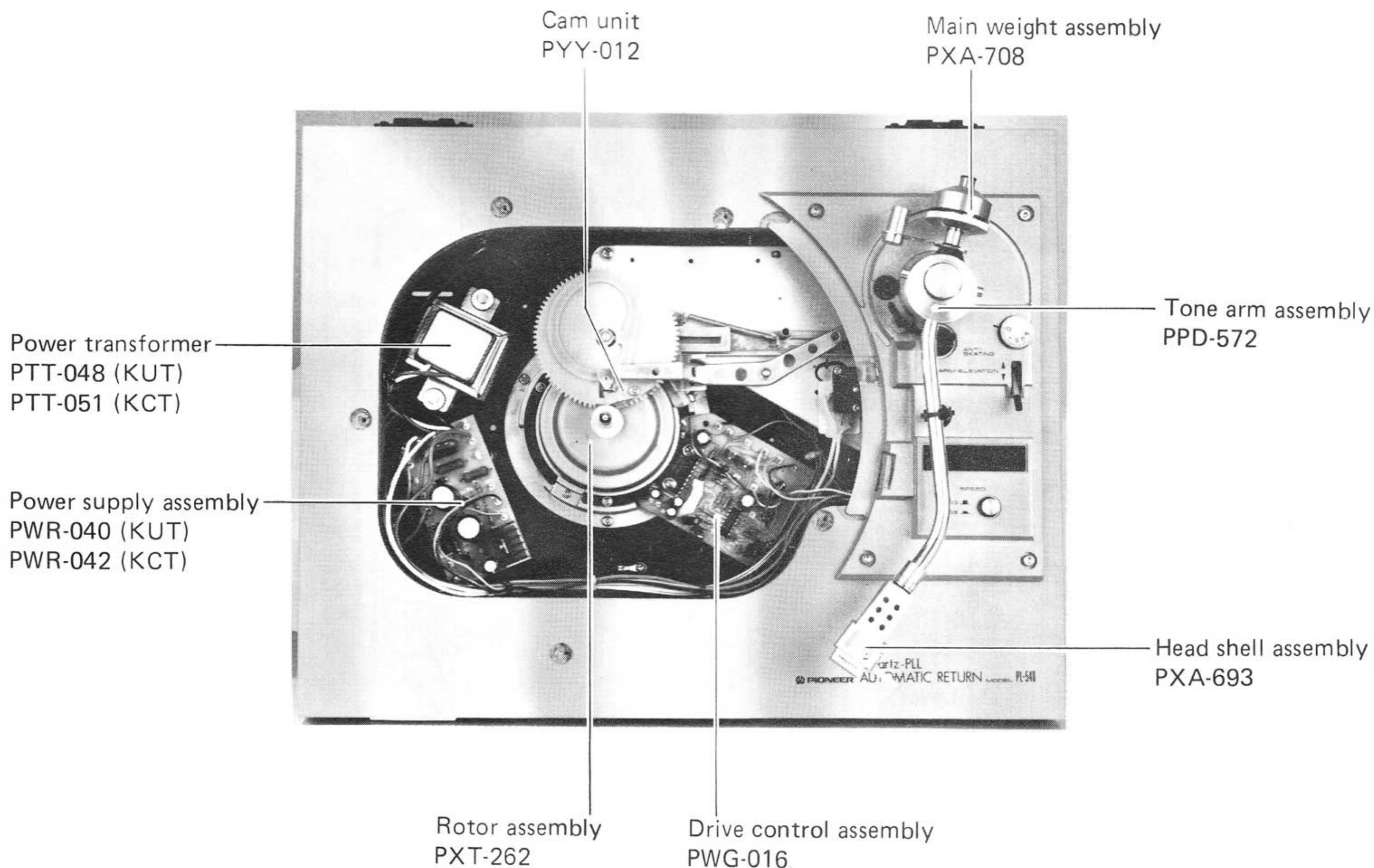

5. MECHANISM OPERATION AND ADJUSTMENT

5.1 START OF PERFORMANCE

1. The tonearm is moved from the arm rest to above the turntable.
2. Lever A, connected to the tonearm, unlocks lever B, and the microswitch is turned ON (Fig. 1).
3. When the microswitch is turned ON, the motor is started and the turntable begins to rotate.

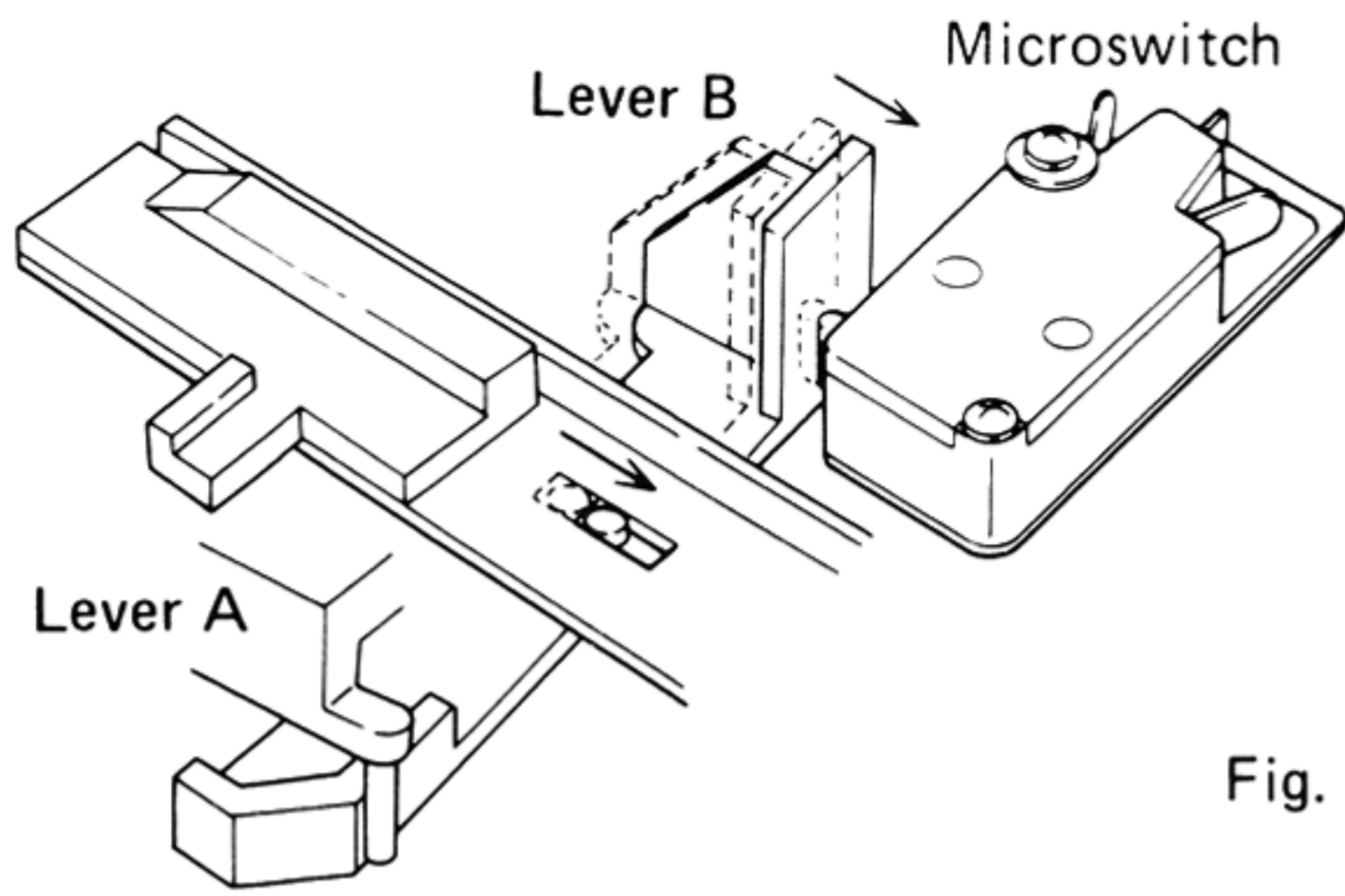

Fig. 1

5.2 AUTO-RETURN DETECTION

1. When the stylus nears the center shaft, lever A contacts lever C (Fig. 2).

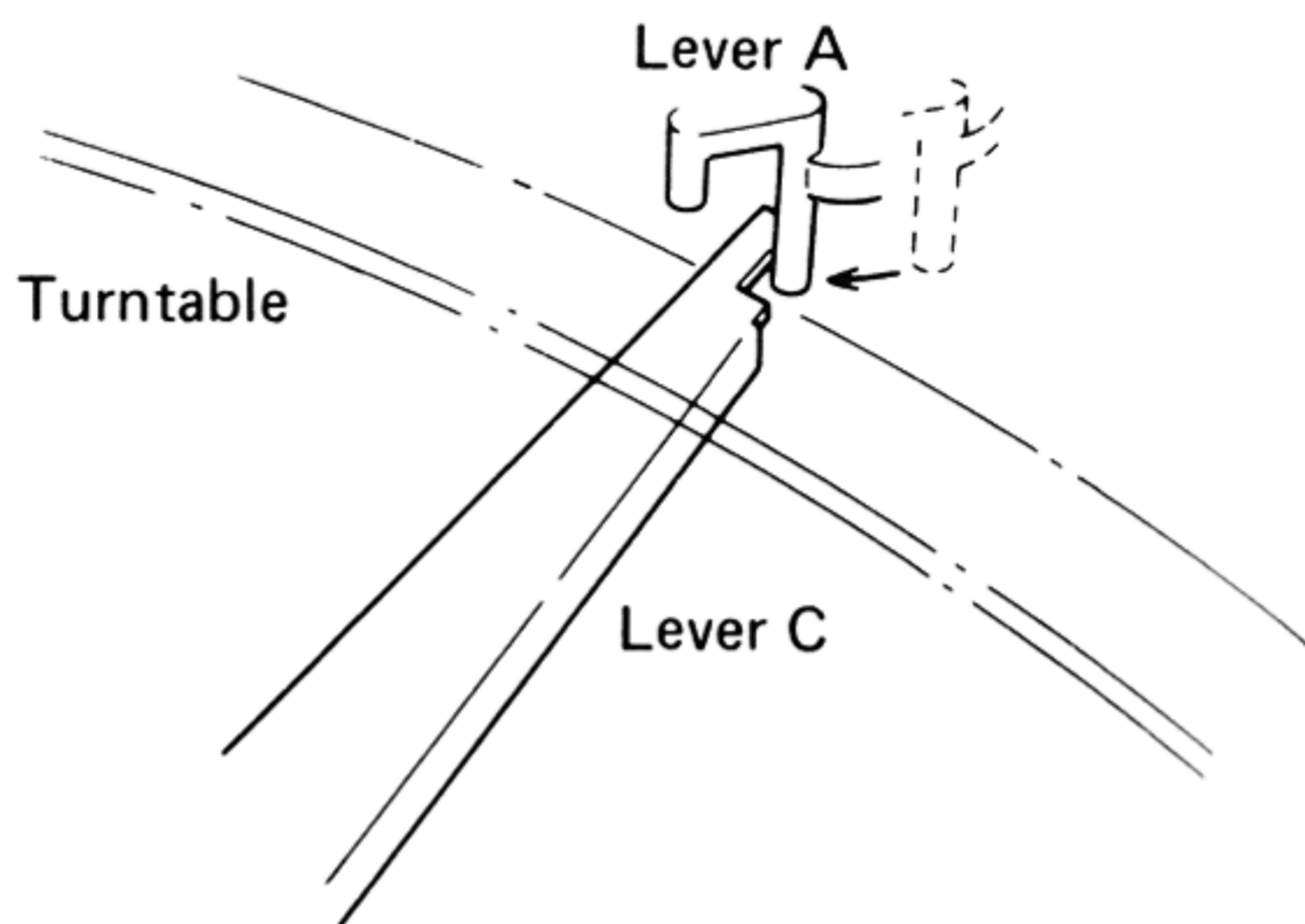

Fig. 2

2. Lever C pushes plate A by an amount directly proportional to the amount of movement of the tonearm (Fig. 3).

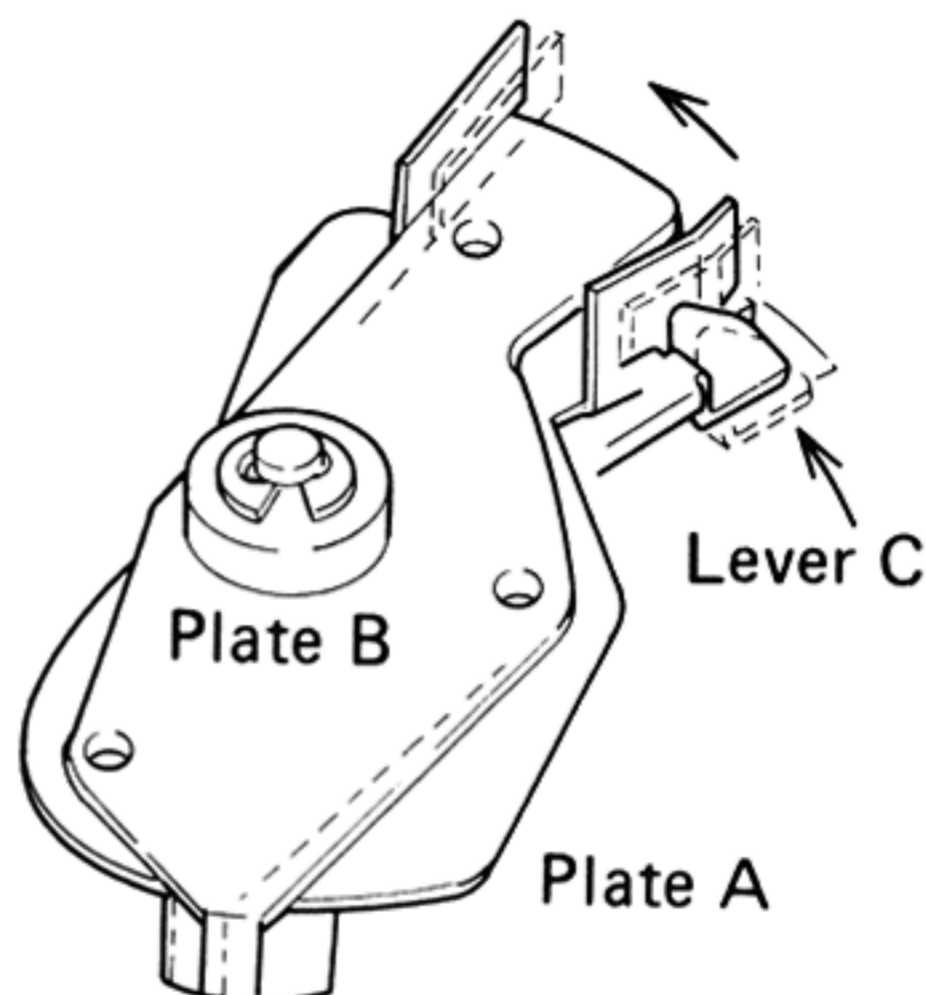

Fig. 3

3. Plate B atop plate A is moved toward gear A by the movement of plate A.
4. The front end of plate B moves approximately 0.1mm when the stylus is advanced 1mm toward the center shaft by one revolution of the record.
5. The tooth of gear A has the dimensional difference shown in Fig. 4-a.
6. Plate B is pushed back by this dimensional difference at a stylus movement of within 1mm per revolution of the record.
7. When the stylus enters the lead-out groove in the record at the end of the performance, it is moved 4mm toward the center shaft by one revolution of the record.
8. The end of plate B contacts the tooth of gear A (Fig. 4-b).
9. Gear A and gear B are engaged, and gear B is turned by rotation of the turntable.

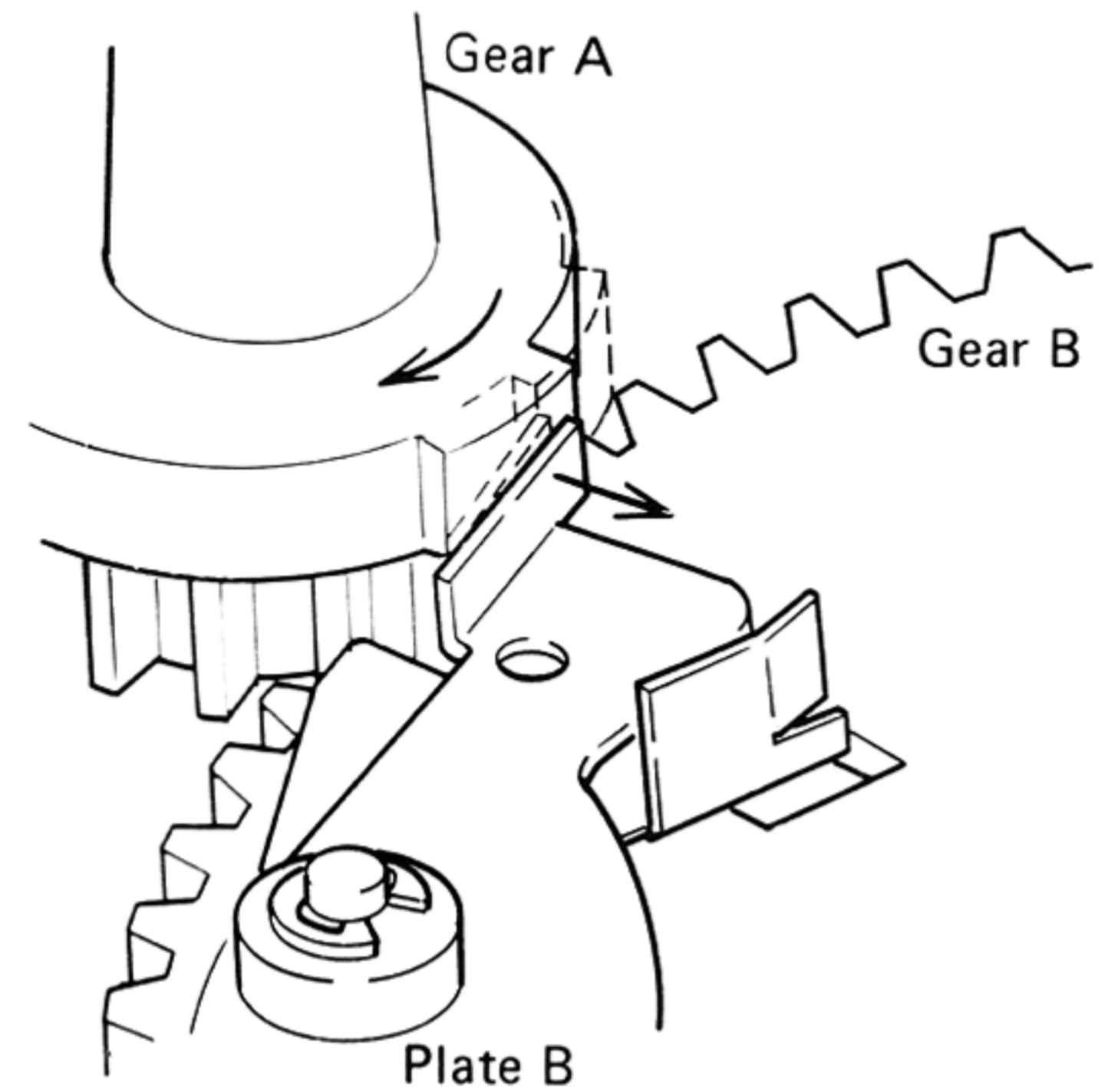

Fig. 4-a

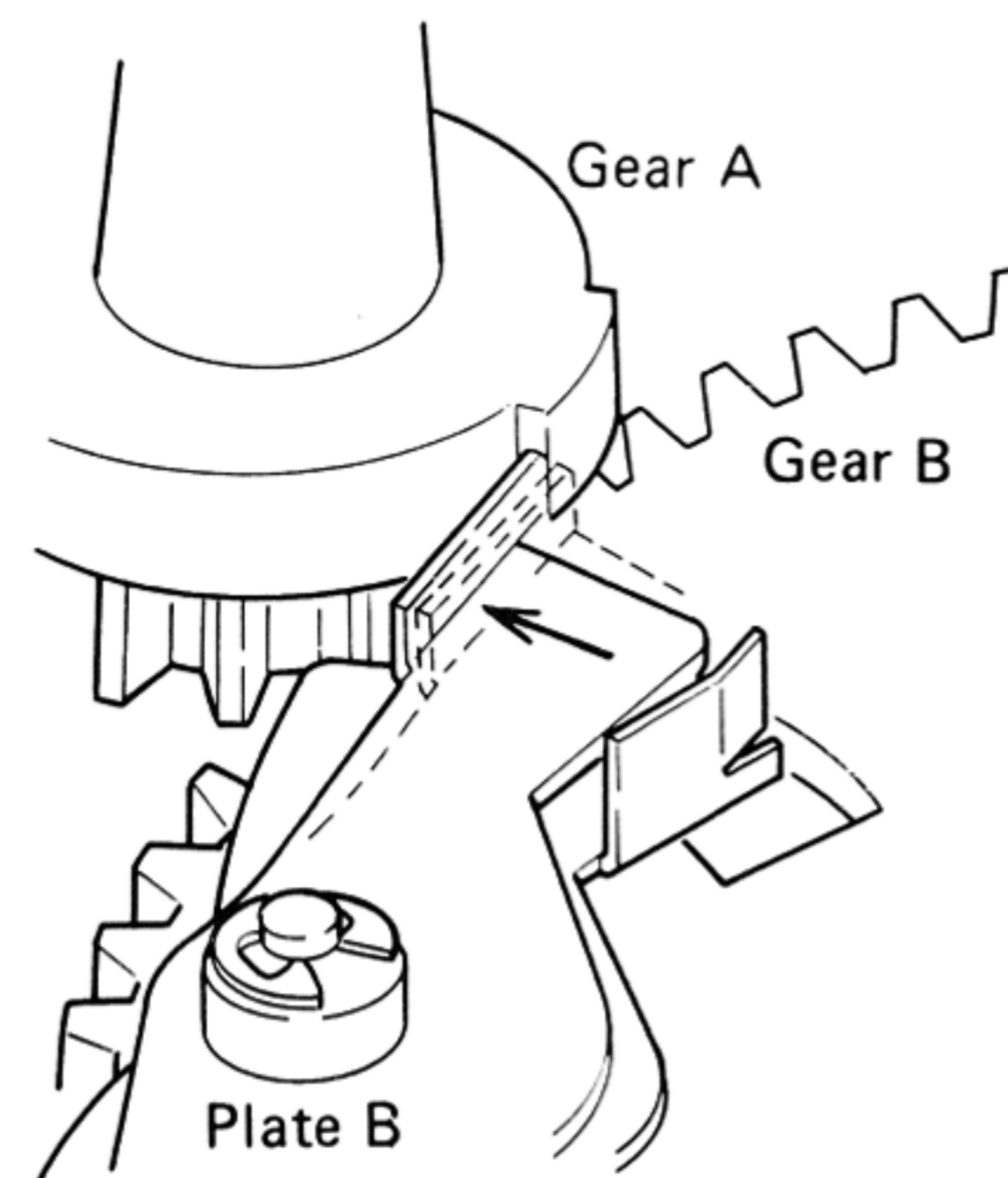

Fig. 4-b

5.3 AUTO-RETURN OPERATION

1. Gear B is rotated by detection of auto-return.
2. Lever D moves along the groove of gear B, and the tone arm is lifted (Fig. 5).

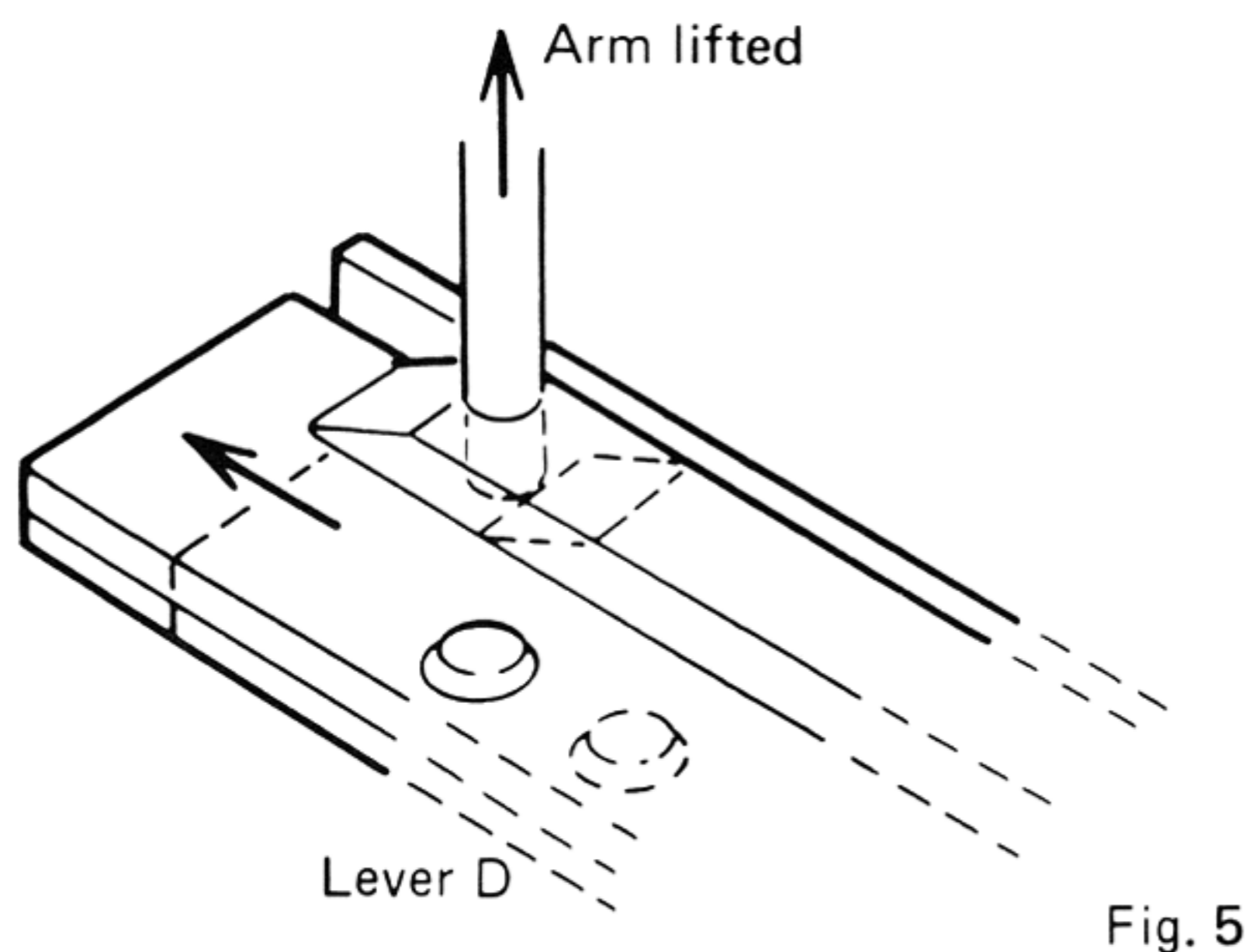

Fig. 5

3. Lever A is pushed and the tonearm is returned to the arm rest by lever D (Fig. 6).

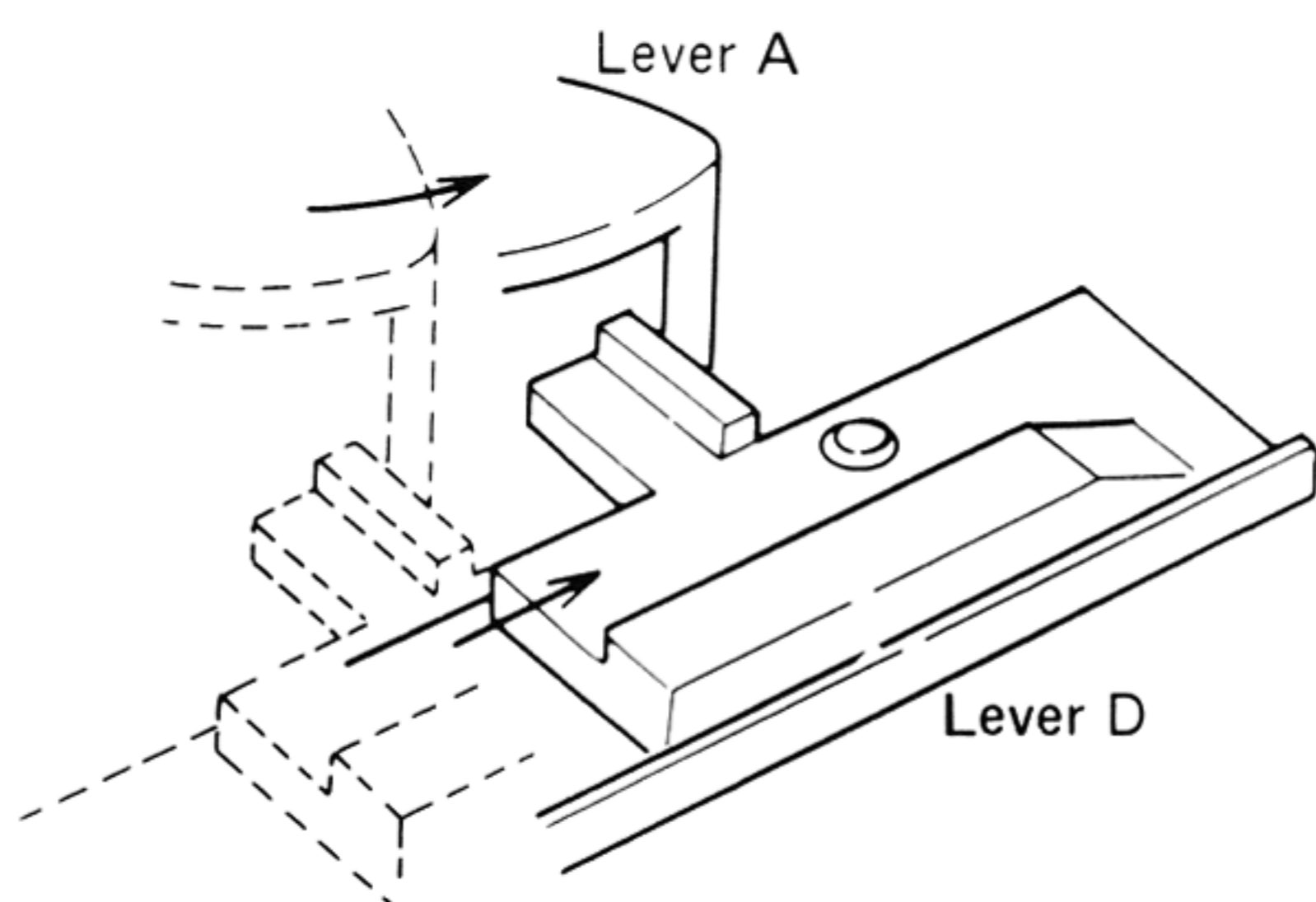

Fig. 6

4. When gear B has rotated one revolution, lever D is returned to its original position.
5. When lever D has returned to its original position, lever B is pushed by lever A and the microswitch is turned OFF (Fig. 7).
6. When the microswitch is turned OFF, the motor is stopped, and the turntable also stops.

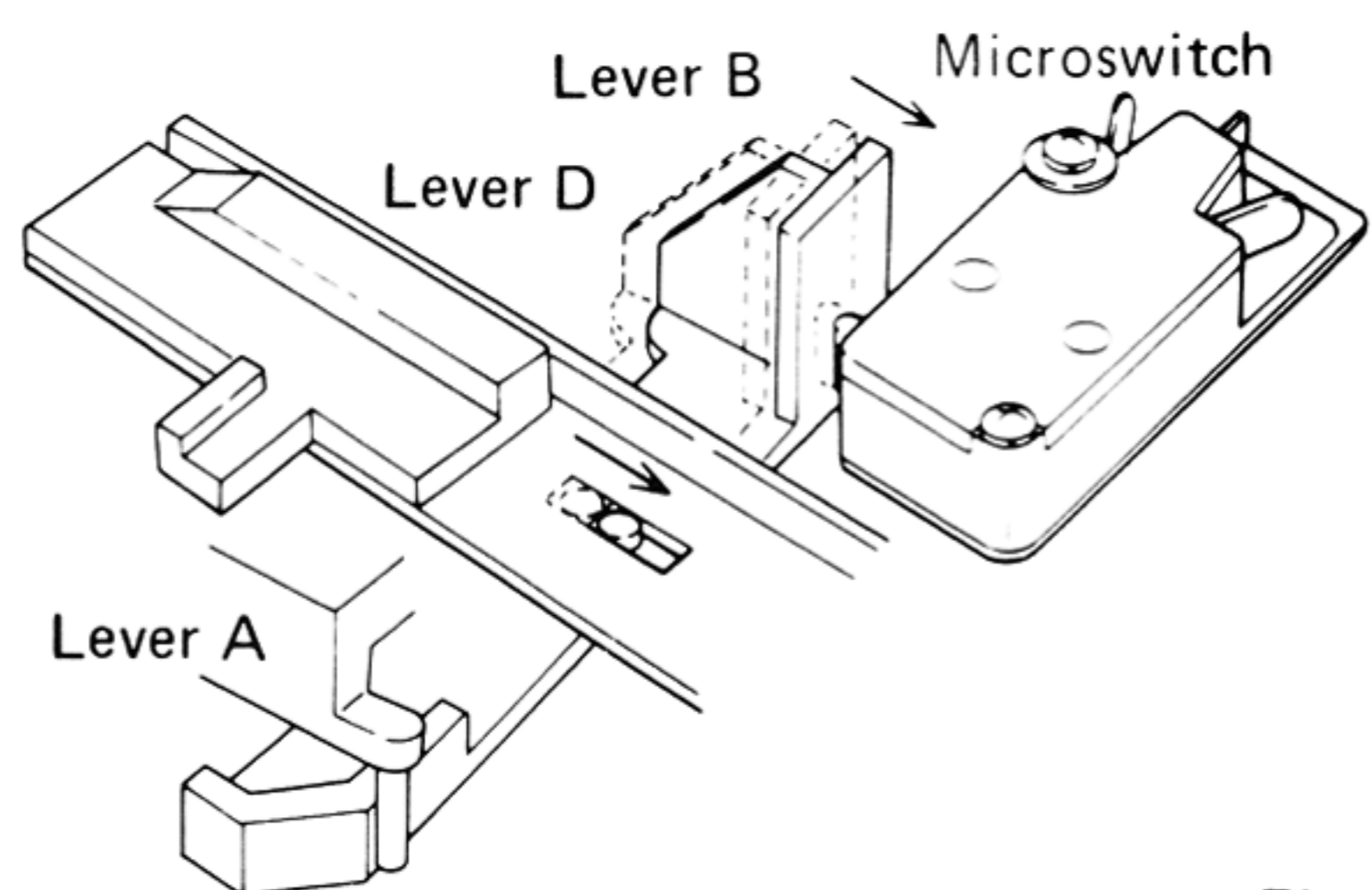

Fig. 7

5.4 ADJUSTMENT

5.4.1 Auto-return Detection Position

1. Plate B contacts the tooth of gear A, the turntable is rotated, and the auto-return detector is reset.

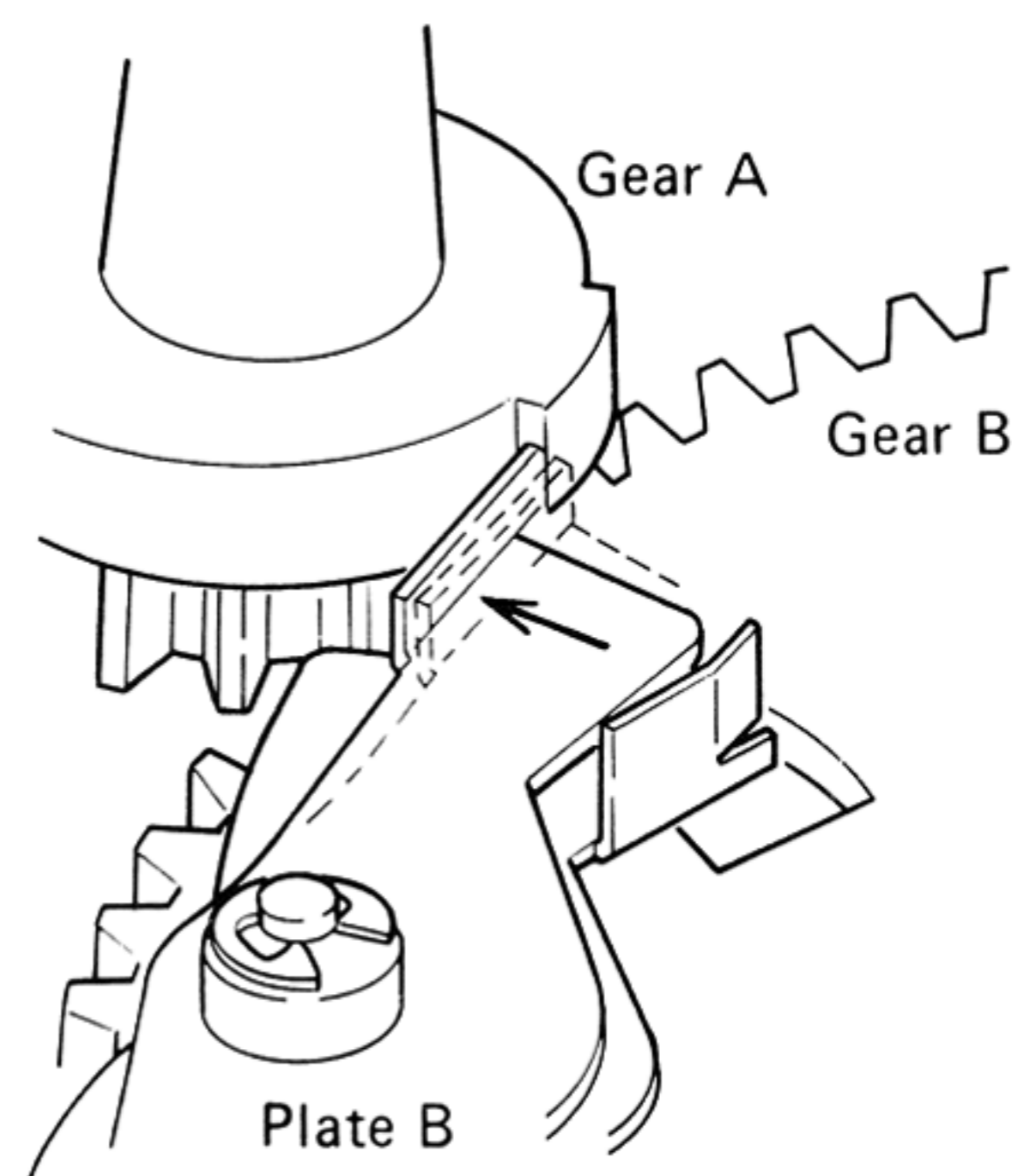

Fig. 8

2. Adjust the adjusting screw so that plate B contacts the tooth of gear A when the stylus has reached a point 62mm from the center shaft.

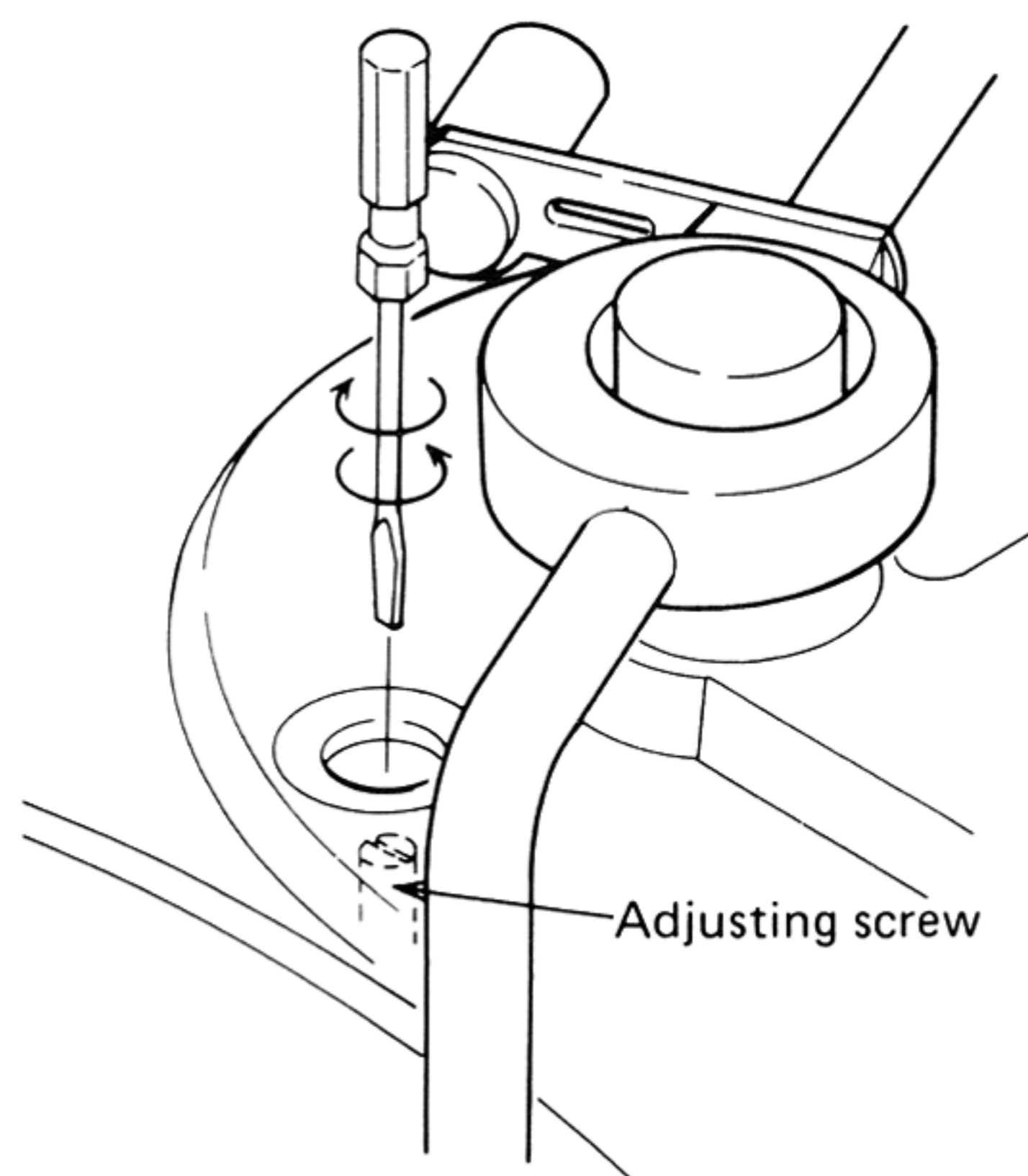
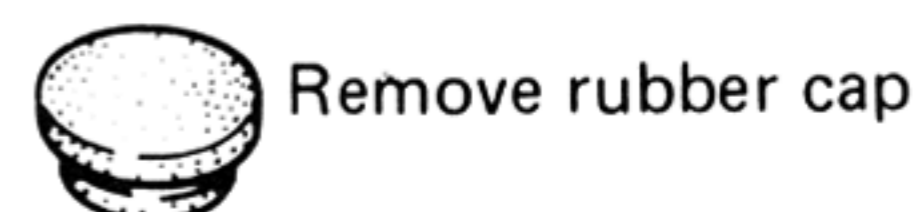

Fig. 9

5.4.2 Microswitch ON Timing

1. Adjust at the adjusting point shown in Fig. 10-b so that lever A and lever B become as shown in Fig. 10-a when the tonearm is fastened to the arm rest.
2. Adjust the adjusting screw (Fig. 10-c) so that lever B and the microswitch are positioned as shown in Fig. 10-c when the tonearm is fastened to the arm rest.
3. Since this adjustment will adversely effect the auto-return detection position, the auto-return detection position must be readjusted.

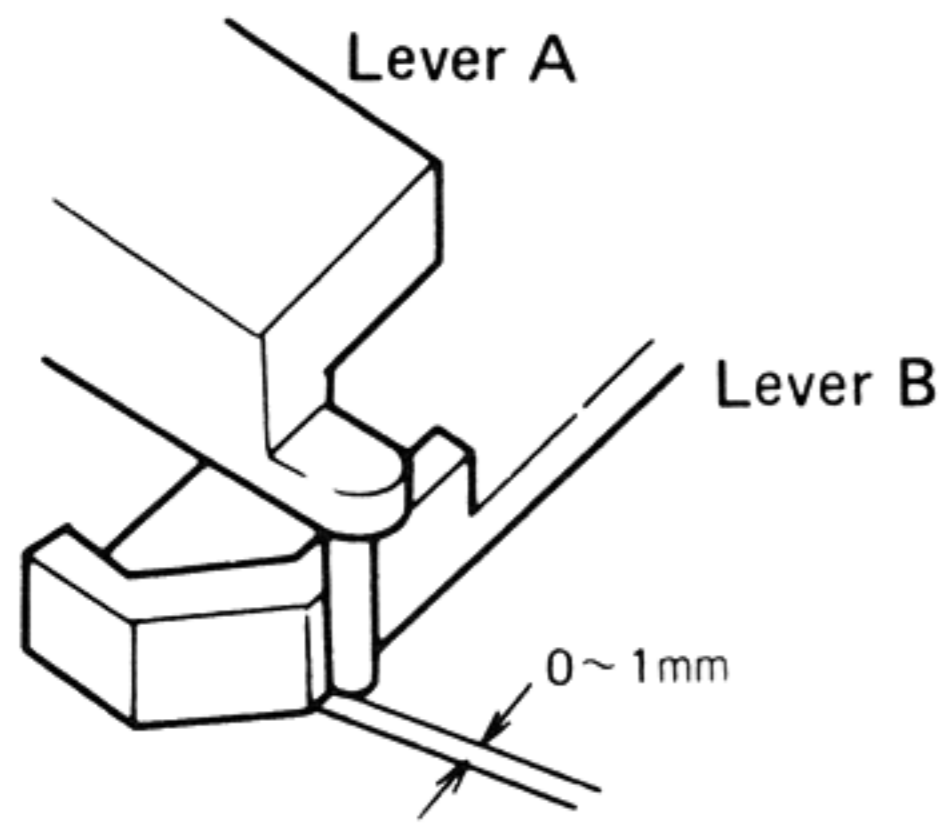

Fig. 10-a

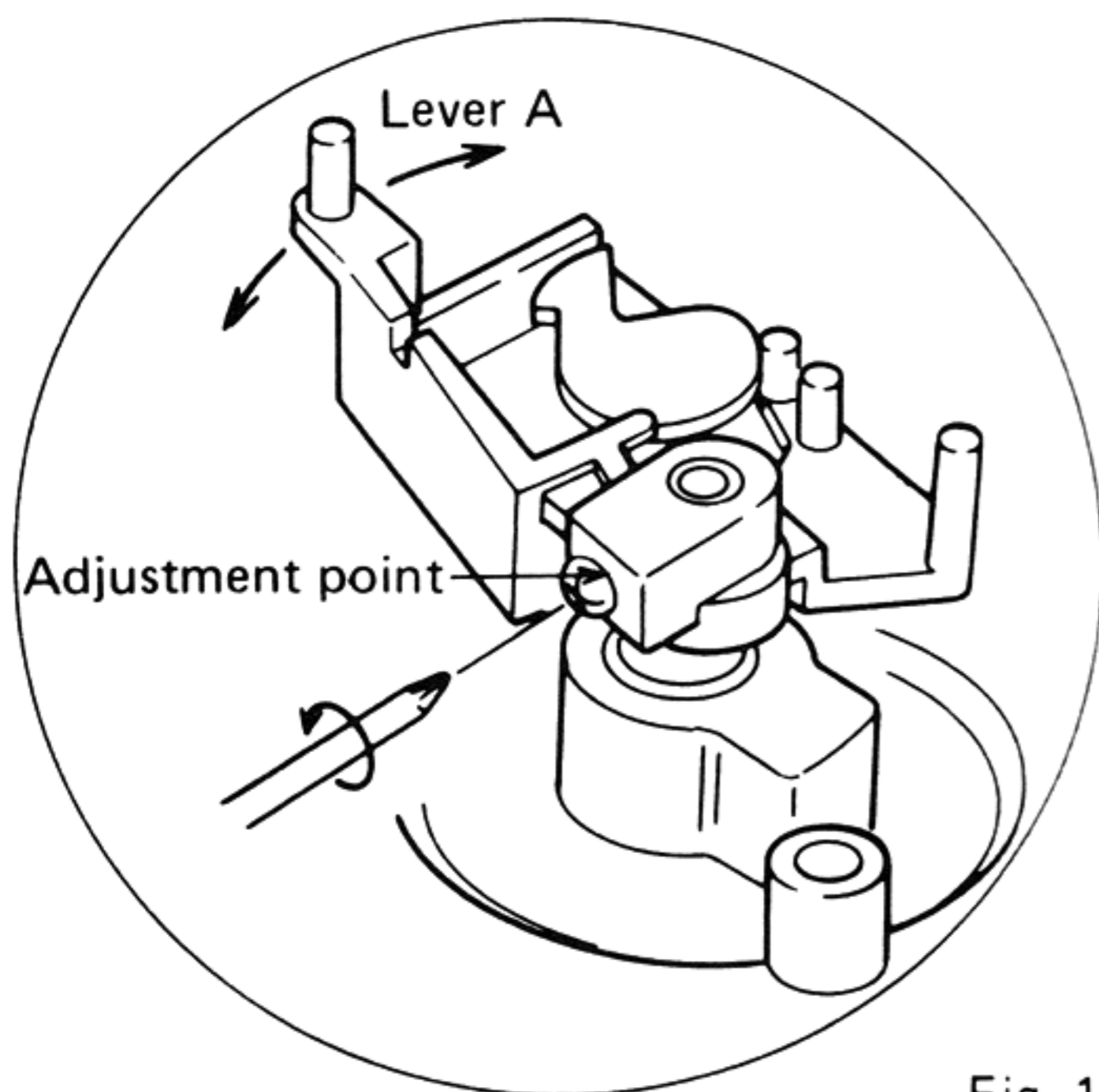

Fig. 10-b

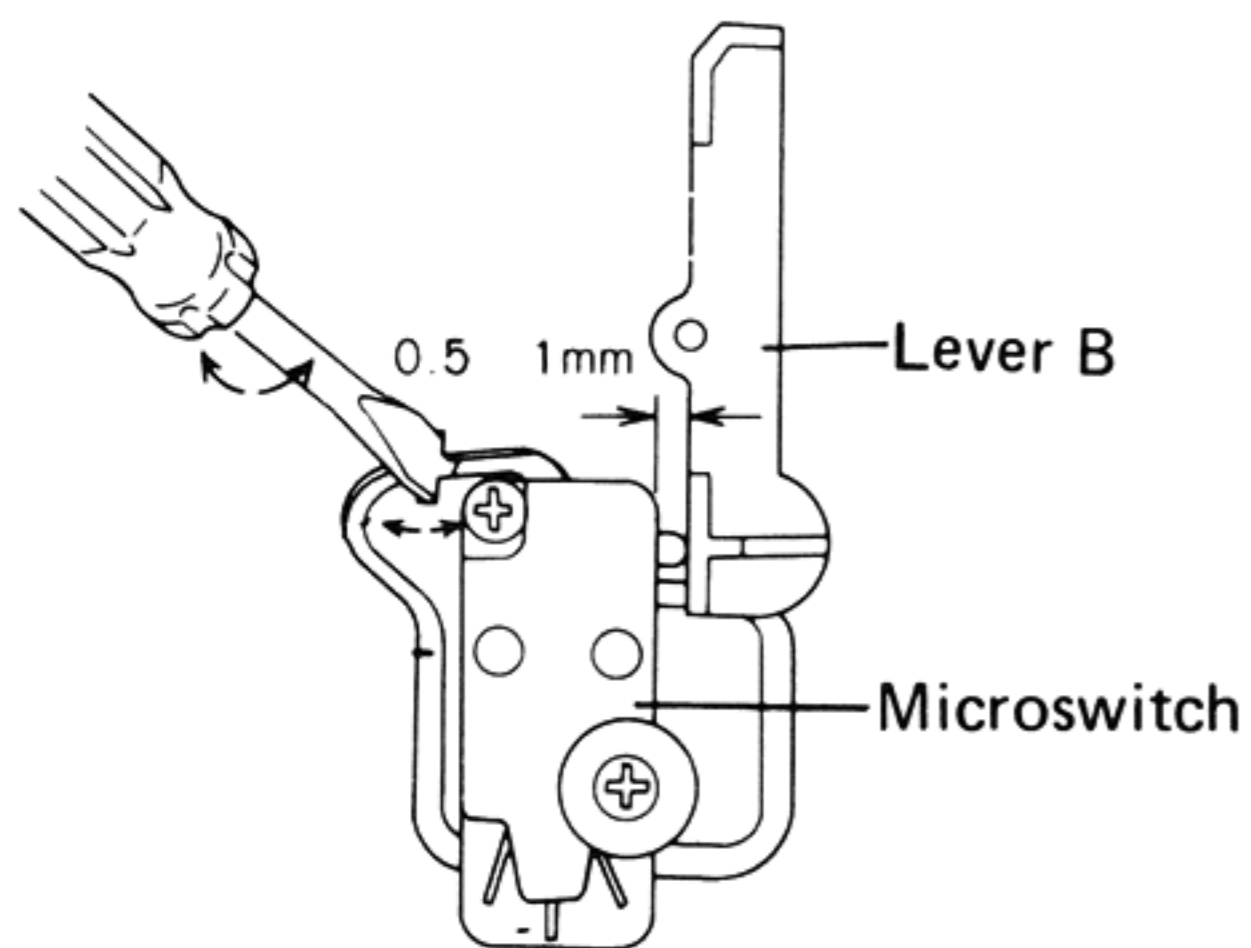
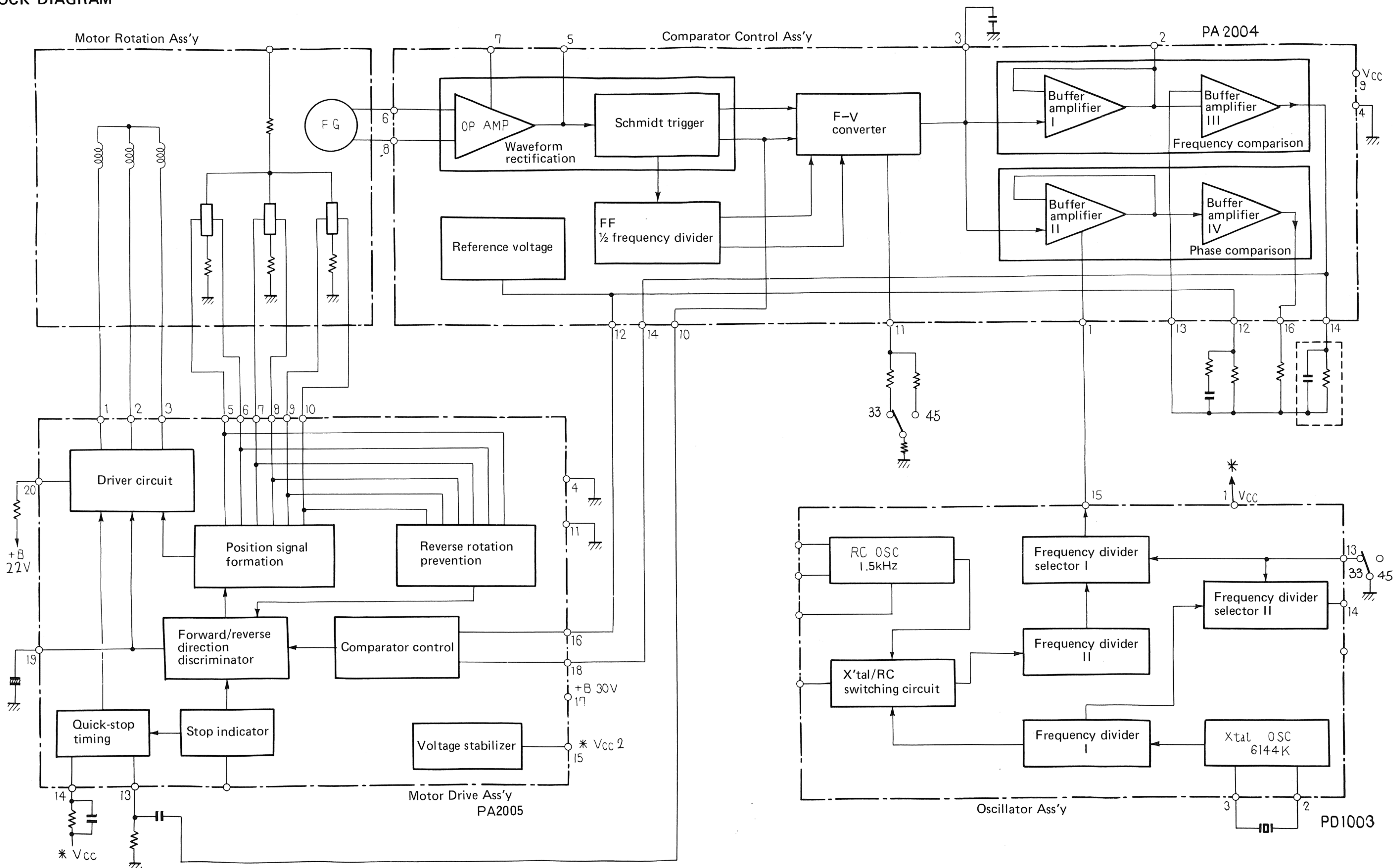

Fig. 10-c

6. CIRCUIT DESCRIPTIONS

6.1 BLOCK DIAGRAM



6.2 MOTOR OPERATION

1 Motor Construction

1. The PXM-061 is an outer-rotor brushless DC motor with 6 poles and 9 slots.
2. Motor windings are arranged in a 3-phase Y configuration. For detection of the platter position, 3 Hall elements are mounted at 40° intervals.
3. As the motor rotates, these Hall elements generate an AC voltage dependent upon the strength and direction of the magnetic flux.
4. The bottom side of the rotor magnet possesses 200 magnetic poles. As these rotate above the speed detection plate, an AC voltage is generated which serves as the speed detection signal.
5. The inner surface of the rotor magnet possesses 6 magnetic poles. As shown in Fig.13, these are tilted by 22.0° relative to the vertical axis.

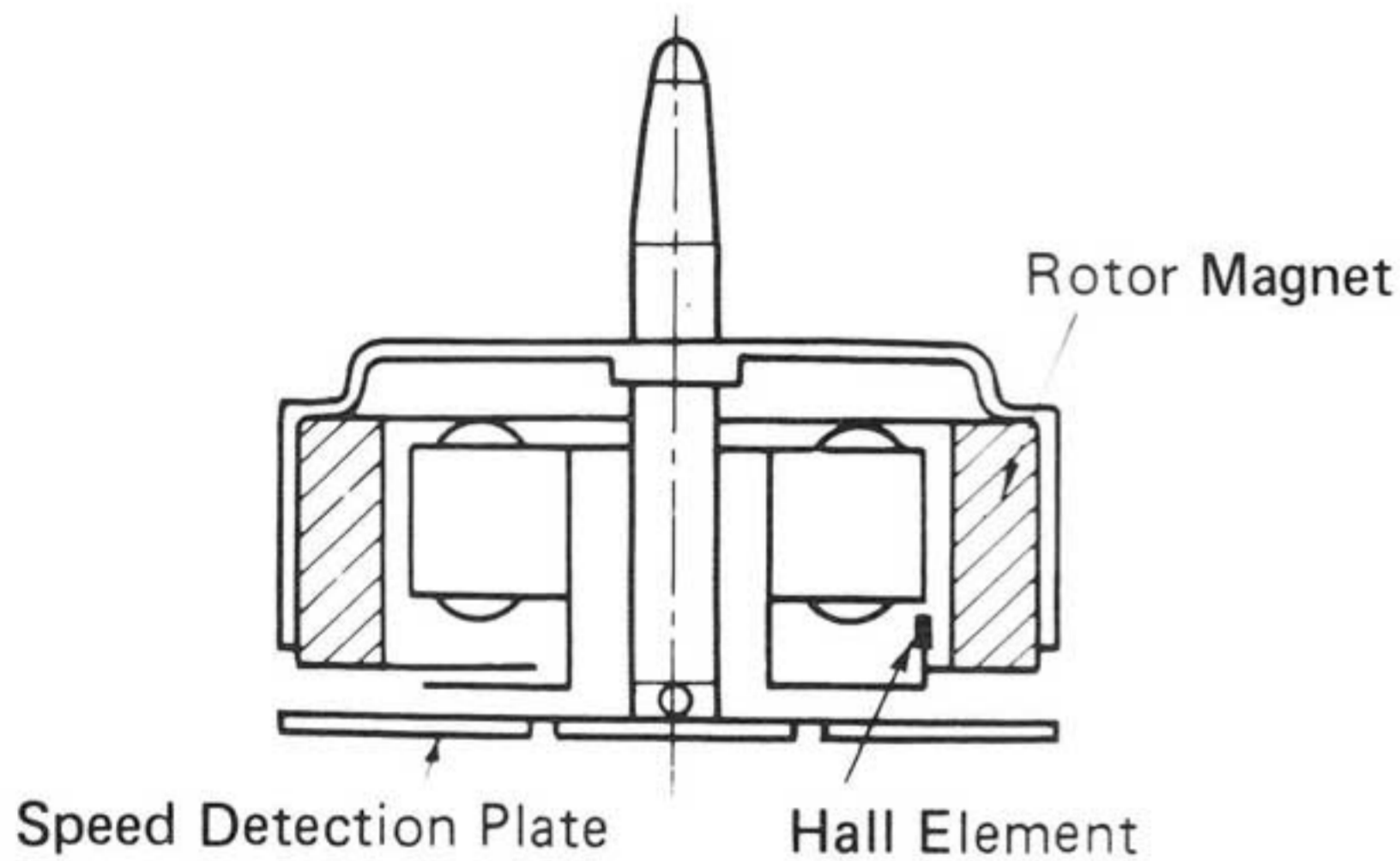

Fig. 12

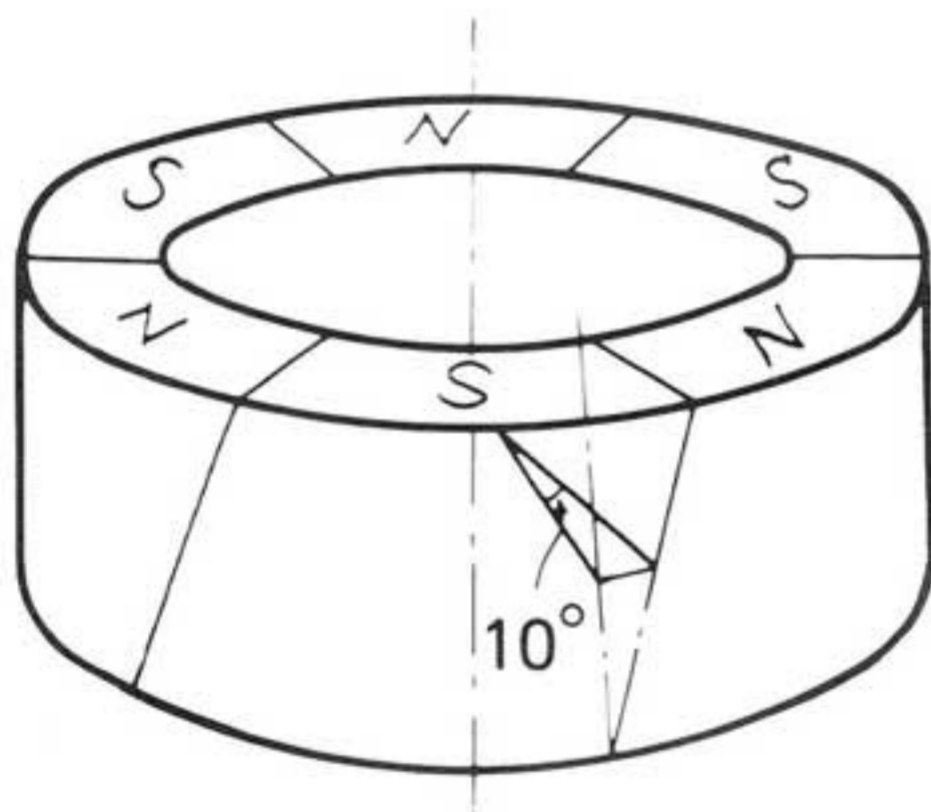

Fig. 13

2. Principle of Motor Rotation

1. Let us assume that the motor is at standstill, in the position shown in Fig. 3.
2. In this position, Hall element H_A is located next to a borderline between south and north poles, H_B next to a south pole, and H_C next to a north pole.

3. When the unit is switched on, the output voltages of the respective Hall elements will be as shown in Fig. 20-a, page 12.
4. The Hall element output is applied to the Position Signal Combination Circuit contained in IC PA-2005 and utilized to control the current flowing to the motor drive coils. For further details, see paragraph "Drive Circuit."
5. The output from the Hall elements undergoes waveform formation in the Position Signal Combination circuit. The resulting waveforms are shown in Fig. 20-b, page 19.
6. These composite signals are used to switch the drive current in such a way that each motor winding receives the proper current to polarize the magnetic poles for north, south, or OFF in the correct sequence.

In actual rotation, this happens as follows.

7. As the pole of coil L_A becomes a south pole, that of L_B becomes north, and L_C , neutral.
8. Repulsion between the S pole at L_A and the rotor S pole, and attraction between the L_B N pole and the rotor S pole exert a propulsive force on the rotor.
9. As the rotor turns through 20° of arc, the output from the Hall elements changes.
10. L_B now enters OFF state, L_C becomes a N pole, and L_A a S pole.
11. The L_C N pole now attracts the rotor S pole, and the L_A S pole attracts the rotor N pole. Rotation continues.
12. Correspondences between rotor positions and coil polarities are shown in Fig. 15, a-f.

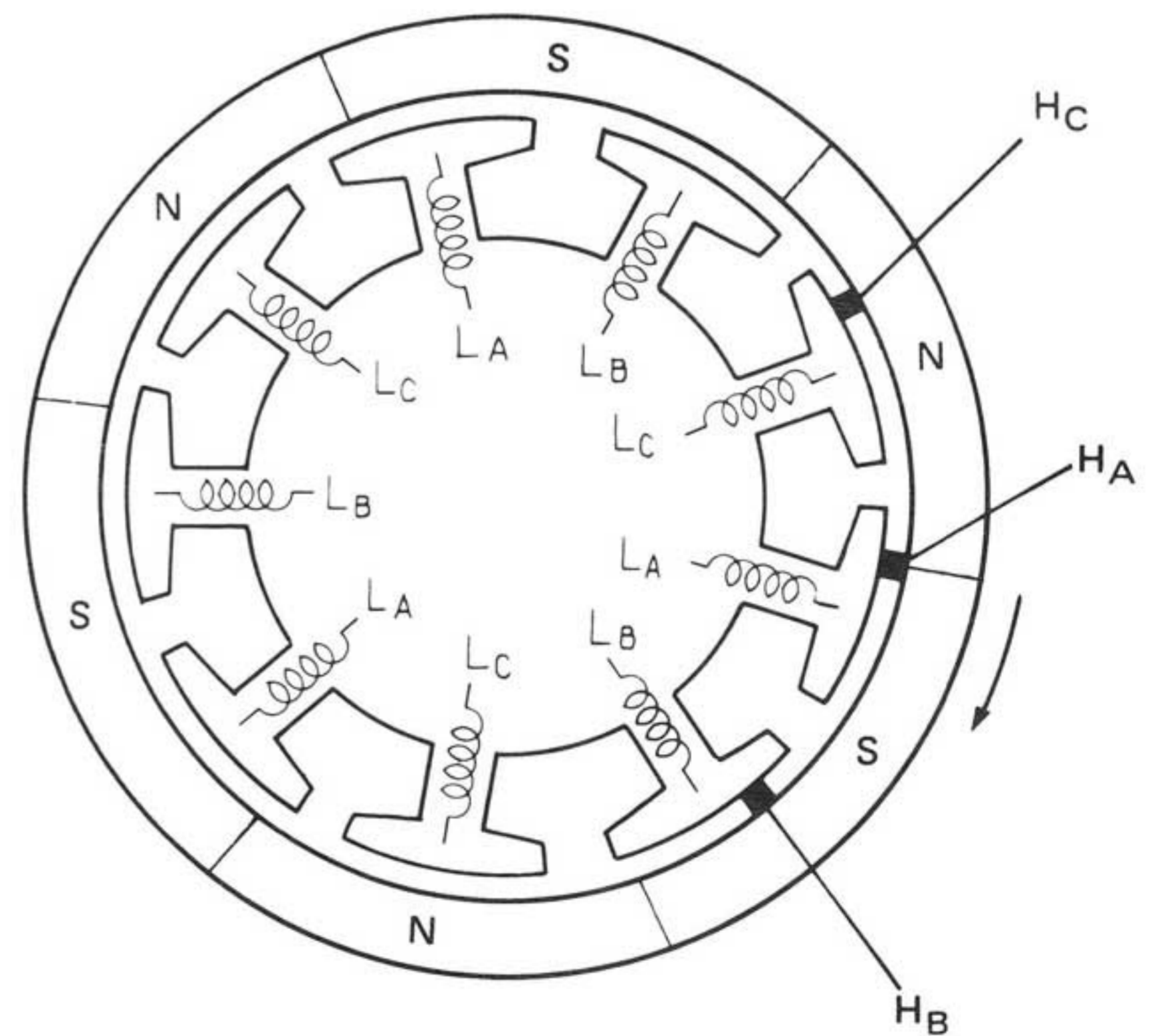

Fig. 14

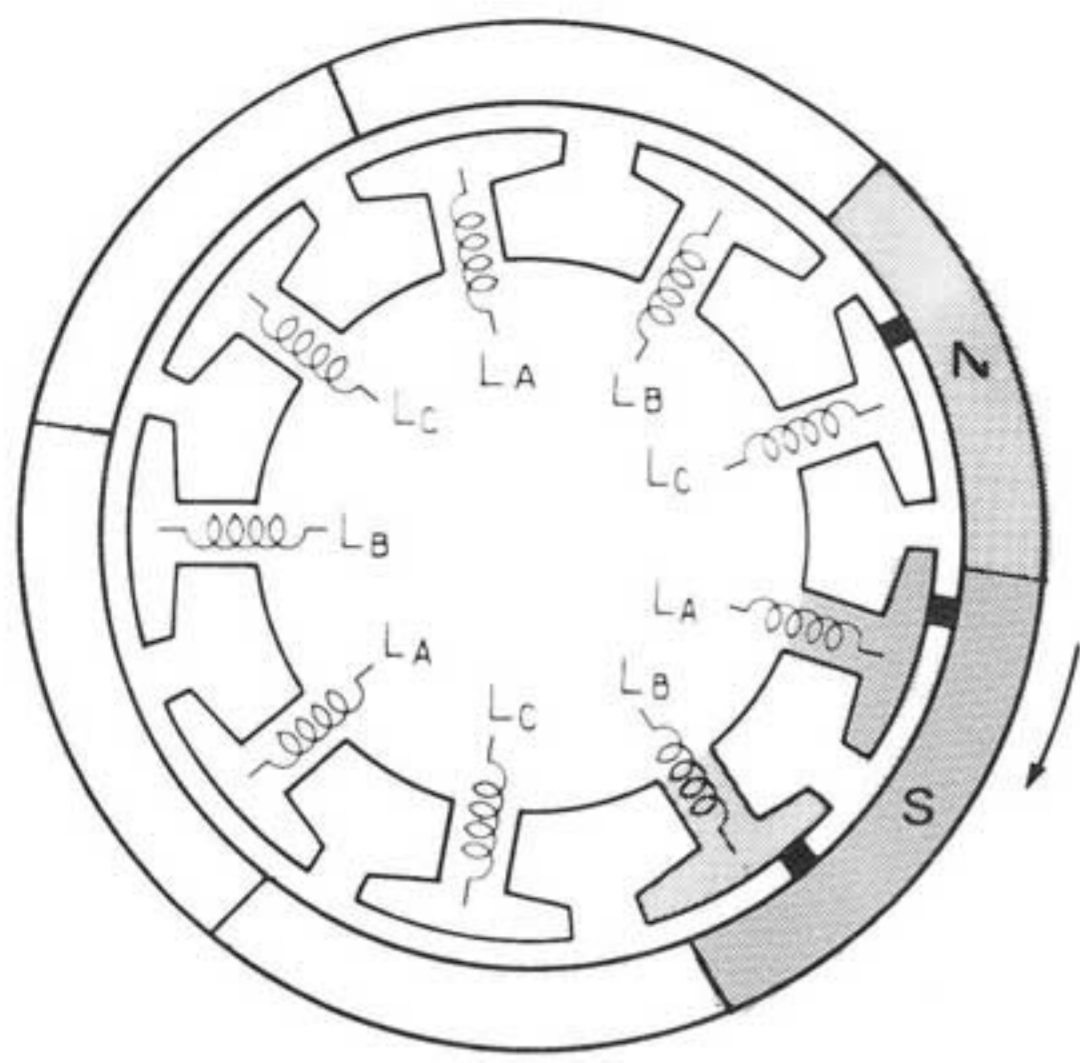

Fig. 15-a

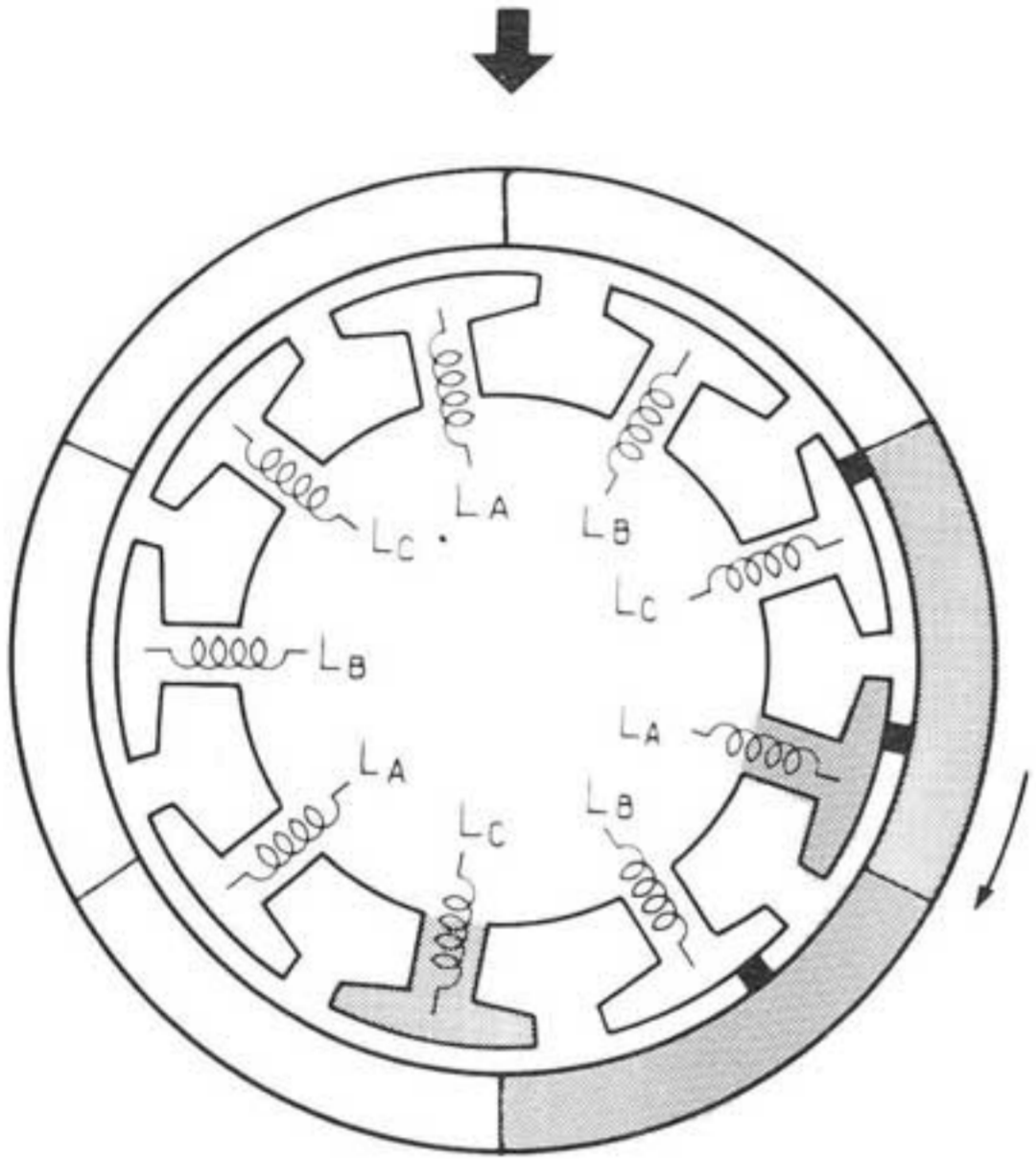

Fig. 15-b

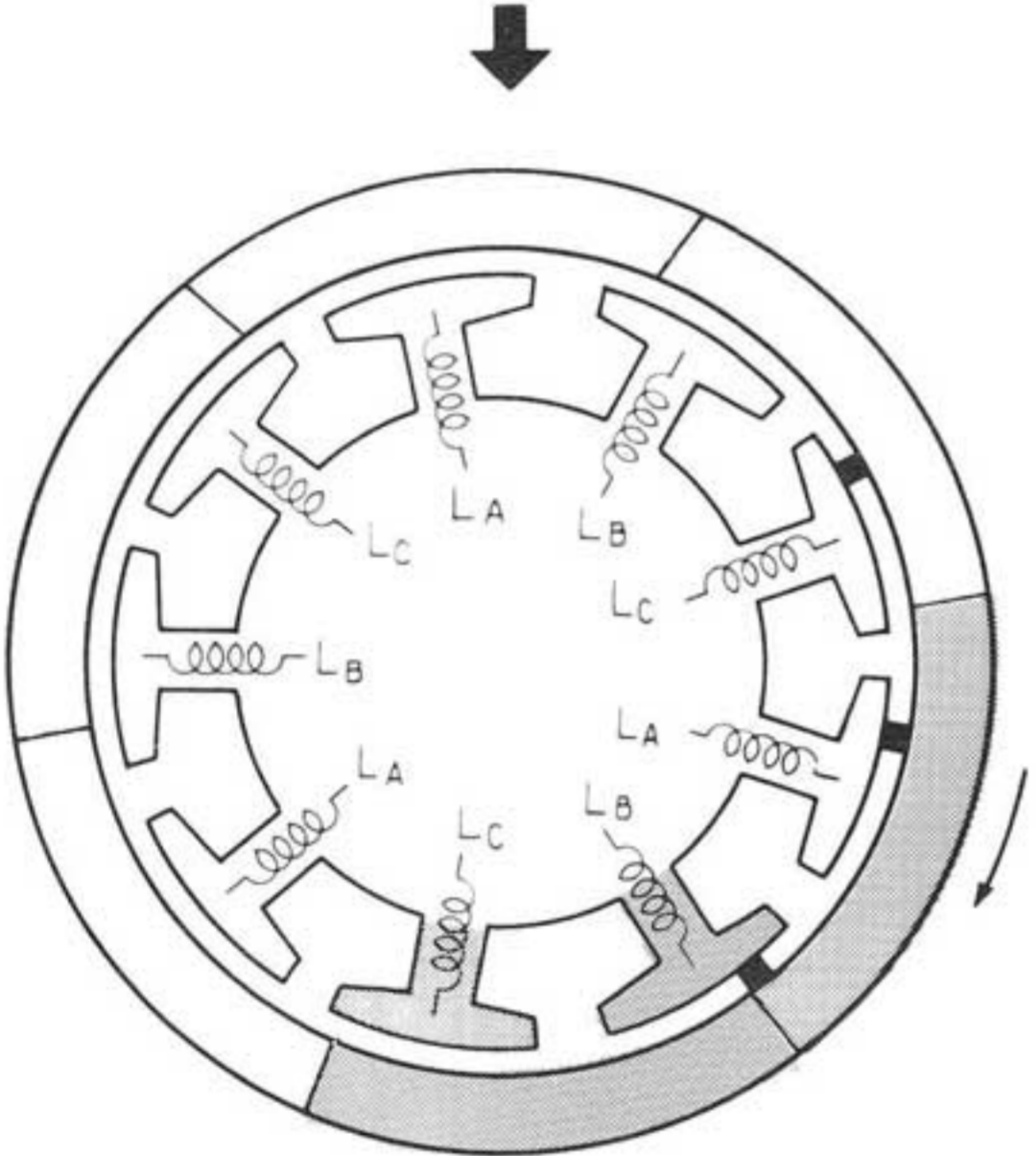

Fig. 15-c

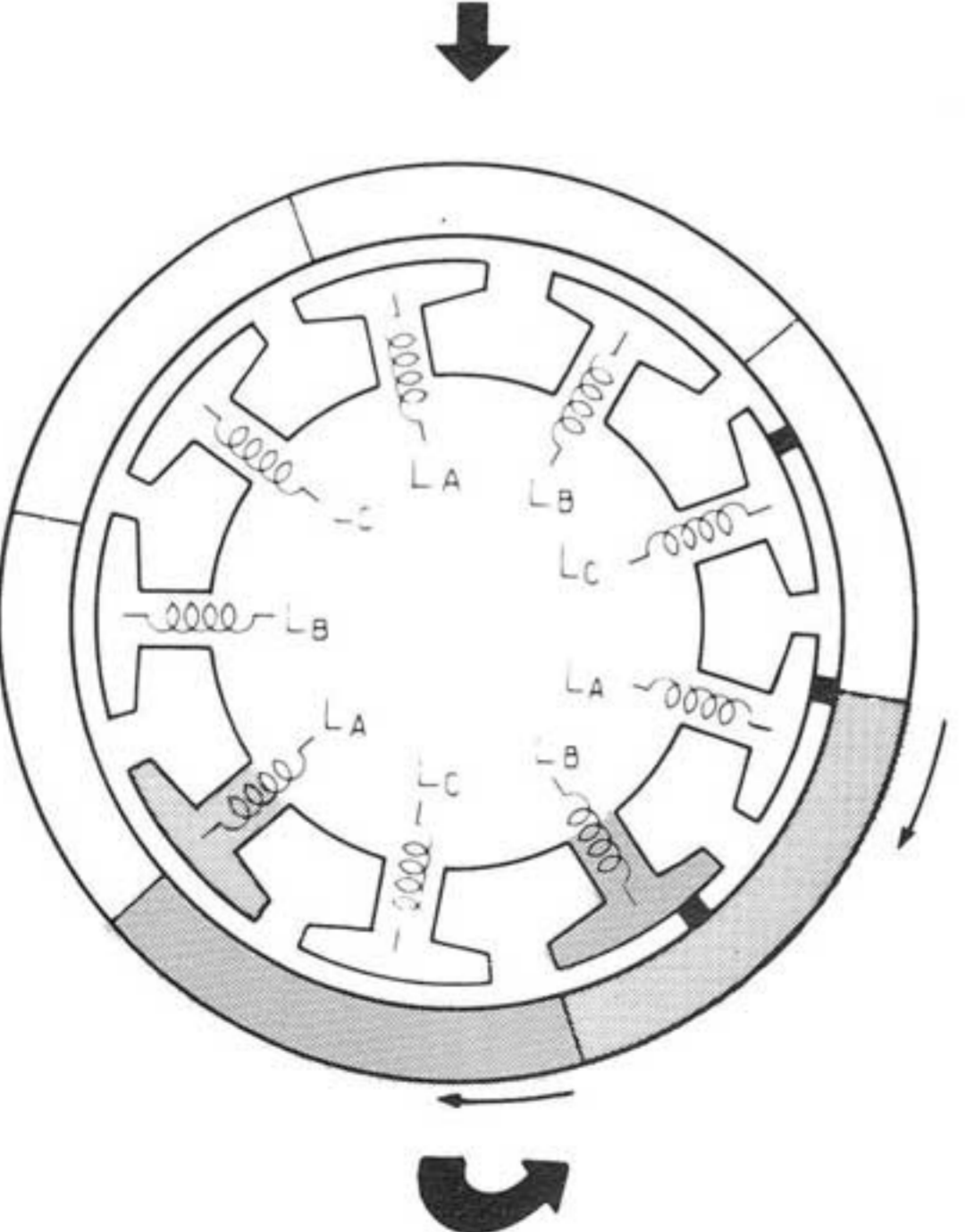

Fig. 15-d

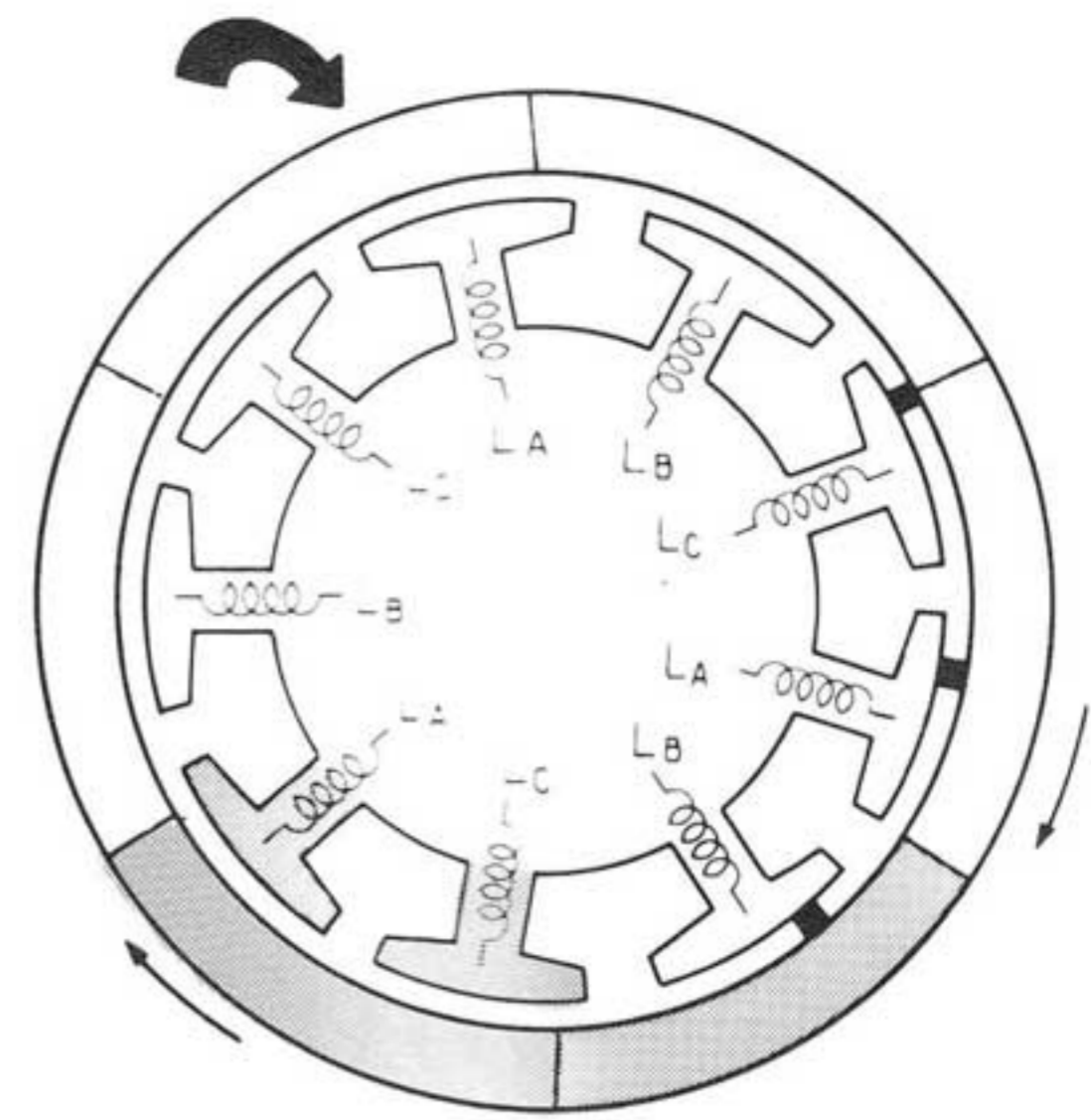

Fig. 15-e

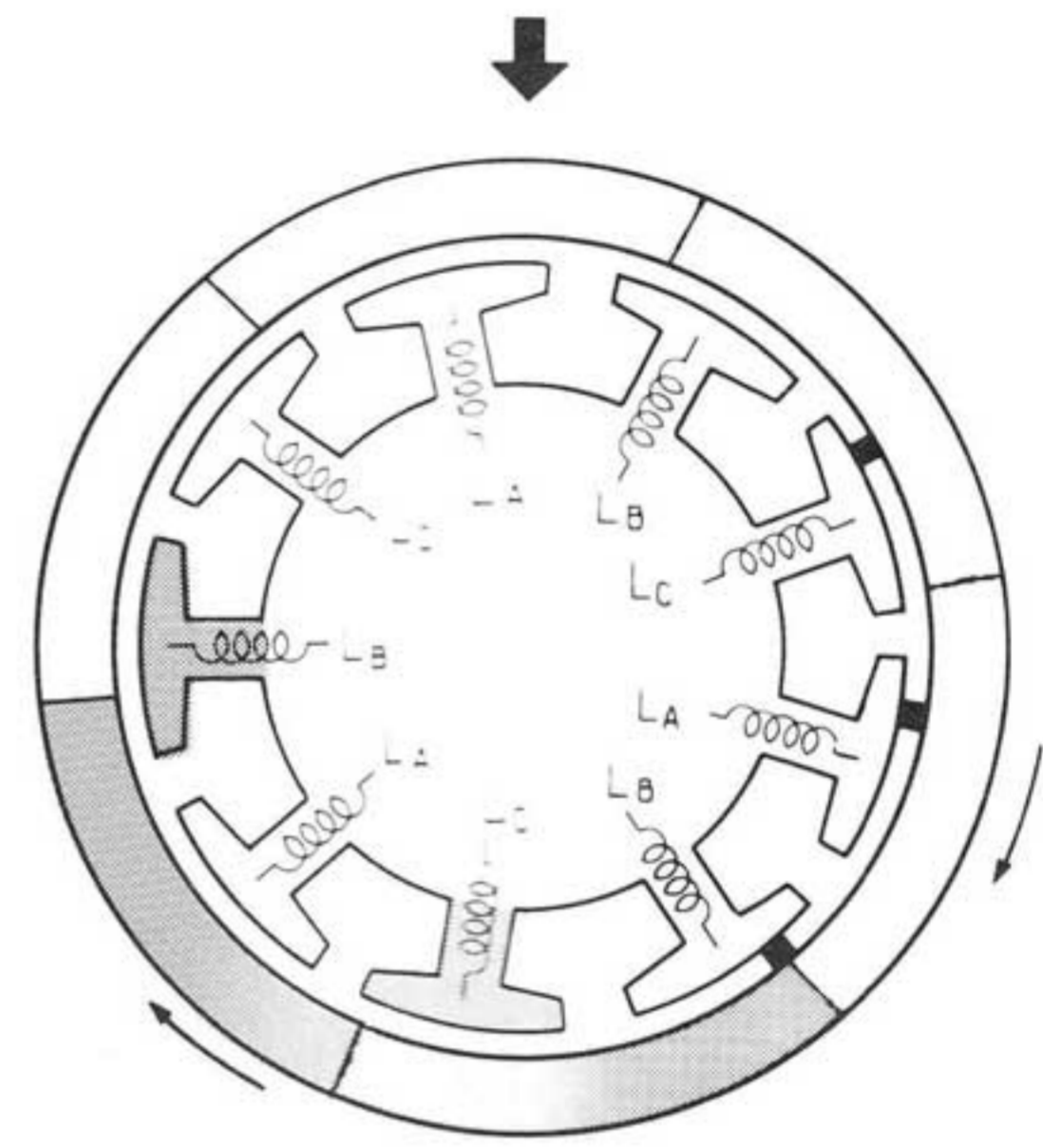

Fig. 15-f

3. Speed Detection Section

1. The speed detection plate has one rows of "detection patterns."
2. The bottom surface of the rotor is magnetized with 200 magnetic poles, and these rotate at a short distance above the speed detection plate.
3. The output voltage from the detection patterns has a frequency of 55.5Hz at 33-1/3 rpm, and of 75Hz at 45 rpm.
4. The signal is supplied to IC PA2004.

6.3 OPERATION OF THE PD1003 IC (OSCILLATOR STAGE)

1. Once the power supply is turned on, the quartz crystal oscillator generates a 6144kHz signal.
2. The frequency of this signal is reduced to 1.5kHz (1/4096 division) by frequency divider I. Part of the resultant signal is passed via the x'tal/RC switching circuit and applied to frequency divider II. The other part of the signal is applied to frequency divider selector II.
3. The 1.5kHz signal applied to frequency divider II is further divided into a 750Hz signal, and applied to frequency divider selector I where the signals are converted into sampling pulses for phase comparison purposes in PA2004.

33rpm 27.78Hz

45rpm 37.5Hz

(In both cases, the pulse width is 0.667ms).

4. Frequency divider selector II converts signals from frequency divider I into pulse signals for the stroboscope lamp drive circuit.

33rpm 55.5Hz

45rpm 75.0Hz

(In both cases, the pulse width is again 0.667ms).

6.4 OPERATION OF THE PA2004 IC (COMPARATOR CONTROL)

1. Signals from the frequency generator in the motor rotation ass'y are changed into 50% duty square wave signals by the waveform rectifier. The frequencies at this stage are thus,

33rpm 55.55Hz

45rpm 75Hz

2. Part of the output is divided by $\frac{1}{2}$ in the FF circuit, and subsequently applied to the FV converter circuit along with the other part of the output formed in step 1 above, thereby forming the FV converter gate pulse signals.
3. The output from the FV converter is applied to buffer amplifiers I and II.
4. The buffer amplifier I output is compared with the reference voltage in buffer amplifier III, and then applied to the output compose circuit.
5. Phase comparison of the sampling pulses from the PD1003 IC with the FV converter output occurs in buffer amplifier II, with the resultant output being applied to buffer amplifier IV.
6. The output from buffer amplifier IV is also applied to the output compose circuit.
7. This output compose circuit consists of a low-pass filter (cut-off frequency 23Hz, cut-off slope -6dB/oct.) which serves to eliminate the carrier component in the output of buffer amplifier II (phase comparison).
8. This final output signal is then passed onto the comparator control stage of the PA2005 IC for comparison with the reference voltage.

6.5 OPERATION OF THE PA2005 IC (DRIVE CONTROL)

● Stroboscope Pulse Circuit

1. The platter has only a single row of stroboscopic markings. Switchover for 45 and 33 rpm is effected by changing the frequency of the pulse to the stroboscopic lamp.
2. From the Frequency Divider Selector I, a frequency of either 75Hz (for 45 rpm, representing 1/80 of 6000Hz) or 55.5Hz (for 33 rpm, representing 1/108) is obtained and supplied to the transistor that drives the stroboscopic lamp.

● Reverse Rotation Prevention

1. PXM-061 operates indiscriminately in regard to the direction of rotation. If the platter is turned slowly in the reverse direction by hand, a forward torque will be applied until the platter stops, reverses its rotation and reaches rated speed in the proper direction.
2. If, however, the rotational speed in the reverse direction is in excess of 33 or 45 rpm, the Forward/Reverse Command Block may "mis-read" this as simply excessive speed ("overrun") and apply a reverse torque until rated speed is attained.
3. This reverse torque will further accelerate the turntable rotation in the reverse direction. This is known as "reverse run-away."
4. To prevent this from happening, a Reverse Rotation Prevention circuit has been included.
5. This Reverse Rotation Prevention circuit consists of two flip-flops and AND gates See Fig. 12.
6. The input for this circuit is derived from the Hall element position detection signals processed in the Reverse Rotation Prevention circuit.
7. As long as the platter is rotating in the proper direction, this pulse enters in the order B — A — C, and no "reverse" command is generated.
8. If, however, the platter rotates in the reverse direction, the pulse order becomes A — B — C, and a corrective command is given to the Forward/Reverse Command Circuit.

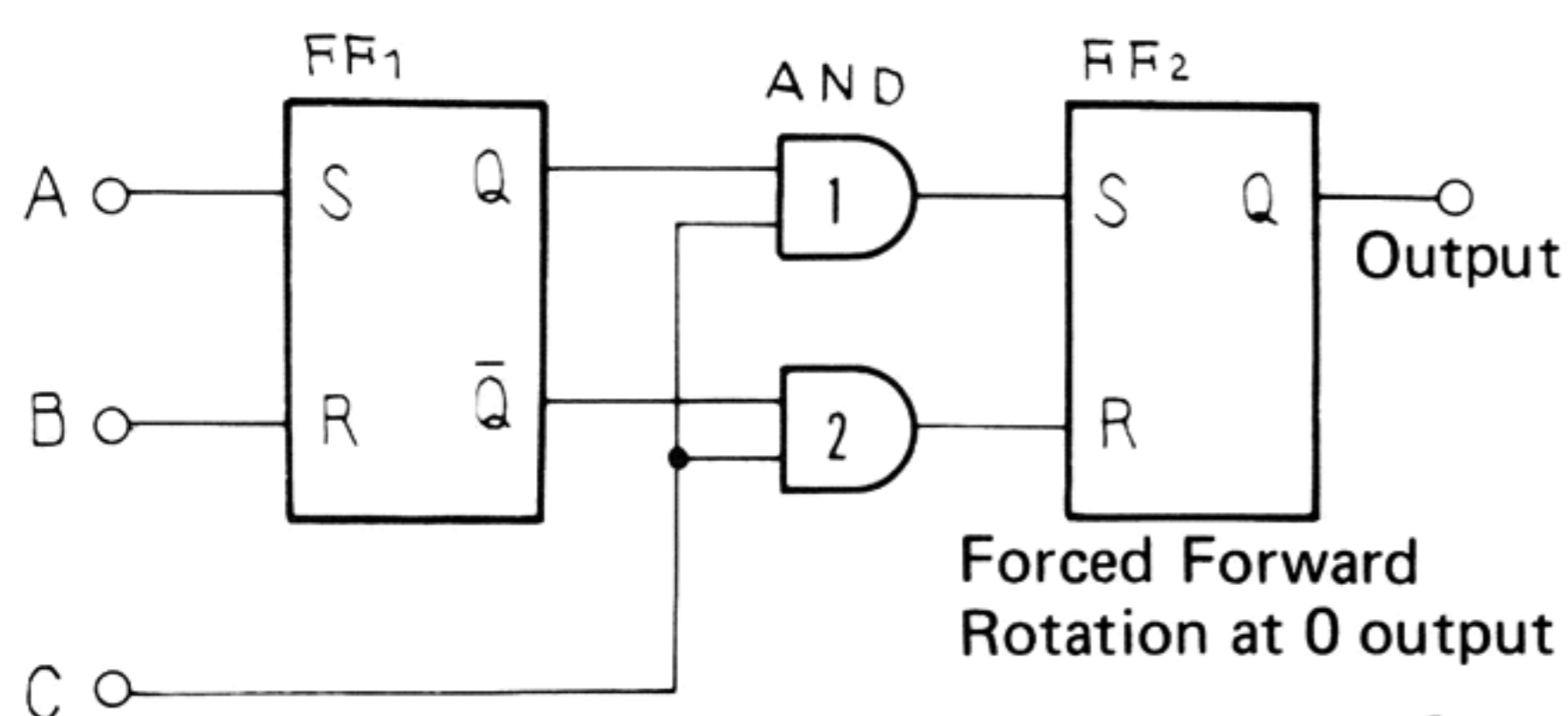

Fig. 16

	FF ₁					C	AND		FF ₂
		S	R	Q	\bar{Q}		1out	2out	Q
Forward rotation	B	0	1	0	1	0	0	0	—
	↓								
	A	1	0	1	0	0	0	0	—
Reverse rotation	↓								
	C	0	0	1	0	1	1	0	1
	A	1	0	1	0	0	0	0	—
	↓								
	B	0	1	0	1	0	0	0	—
	C	0	0	0	1	1	0	1	0

Truth table

● Comparator Control and Forward/Reverse Command Circuit

1. Two inputs are supplied to the Control Comparator: a) a 4V reference voltage from the voltage stabilizer; and b) the output from the active filters, which serves as the detection signal.
2. If the turntable rotates faster than rated speed, the detection signal is higher than the 4V reference.
3. When this happens, the Comparator Control sends a command to the Forward/Reverse Command Circuit, telling it to apply a reverse torque to the motor to slow it down.
4. Conversely, if turntable rotation is below rated speed, the detection signal voltage will be below the 4V reference.
5. In this case, the Comparator Control indicates to the Forward/Reverse Command Circuit that forward torque must be applied to the motor to accelerate it.

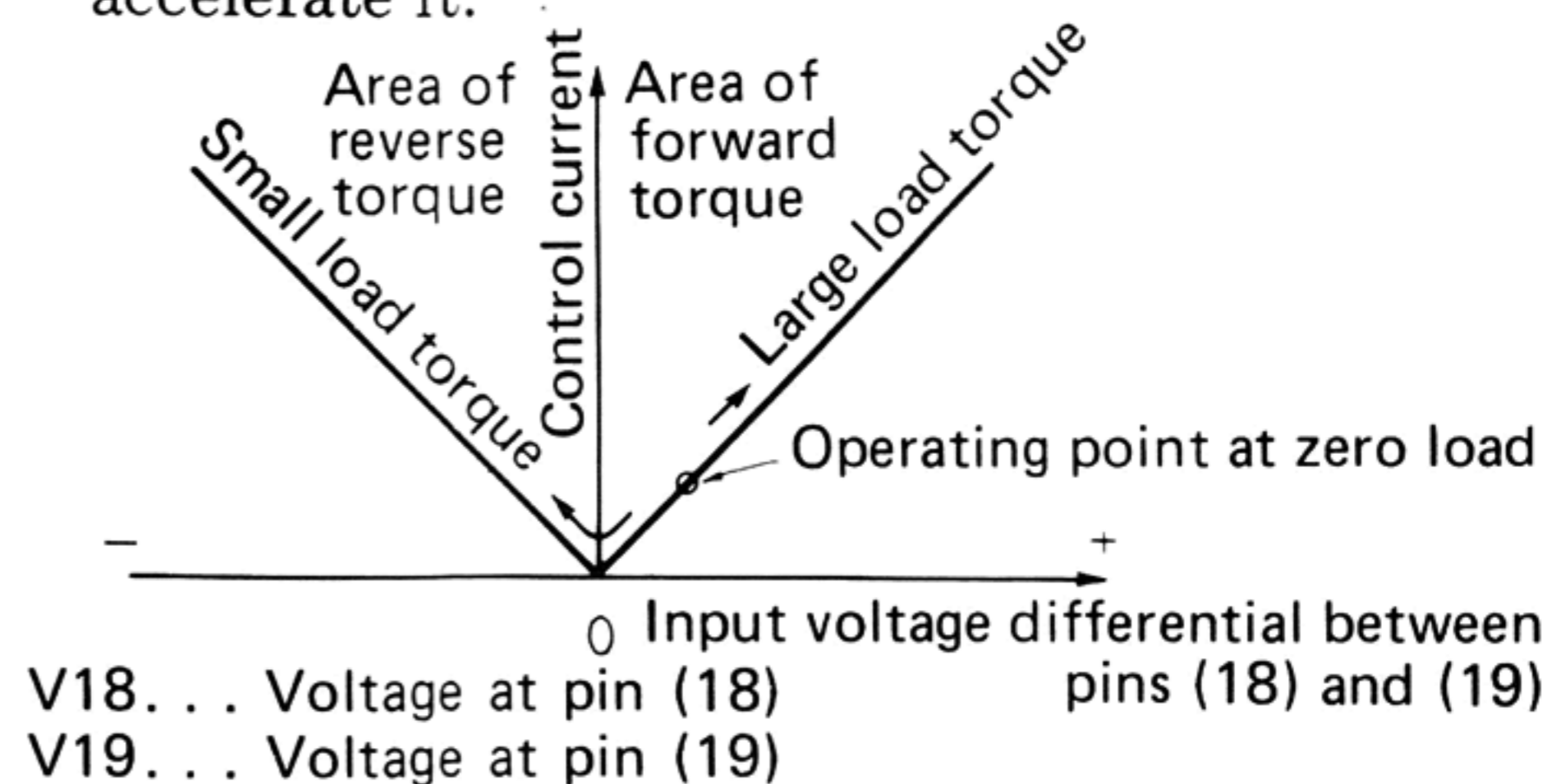

Fig. 17

● Drive Circuit

1. The signals employed in the switching of Q2 ~ Q7 in Fig.18 are generated by 3 Hall elements, and applied to terminals a, b, and c via the position signal formation circuit.
2. The phase of these step waveform signals is displaced by 120° from each other.
3. When the step waveform signals at position I in Fig. 19-a are applied to the drive circuit terminals a, b, and c, the potential at terminal a will be lowered, resulting in Q2 being turned on. The potential at terminal b will be raised, resulting in Q6 being turned on, but the potential at terminal c will remain at the reference level voltage (the bias settings for Q4 and Q7 have been designed to prevent these 2 transistors from operating when a reference level voltage is applied).
4. Vcc will thus be applied across the Q2 - coil L_A - coil L_B - (2) - Q6 route, thereby producing an S polarity in L_A , and an N polarity in L_B .
5. Once the magnetic field is generated, the rotor will commence to rotate. After the rotor turns through 20° , the signals at position II in Fig.19-b will be applied to terminals a, b, and c, thereby resulting in a change in the flow routes of the drive currents. After the rotor turns through another 20° , the signals shown at position III in Fig. 19-c will be applied, again resulting in changes in flow routes of the drive currents. For every 20° that the rotor turns through, the flow routes for the drive currents will change as shown in Figs. 19-d, 19-e, and 19-f, finally returning to the routes shown in Fig.19-a again.
6. A control voltage generated by the forward/reverse direction discriminator indicator circuit is applied to the control input terminal, thereby controlling the flow of current in the coils.

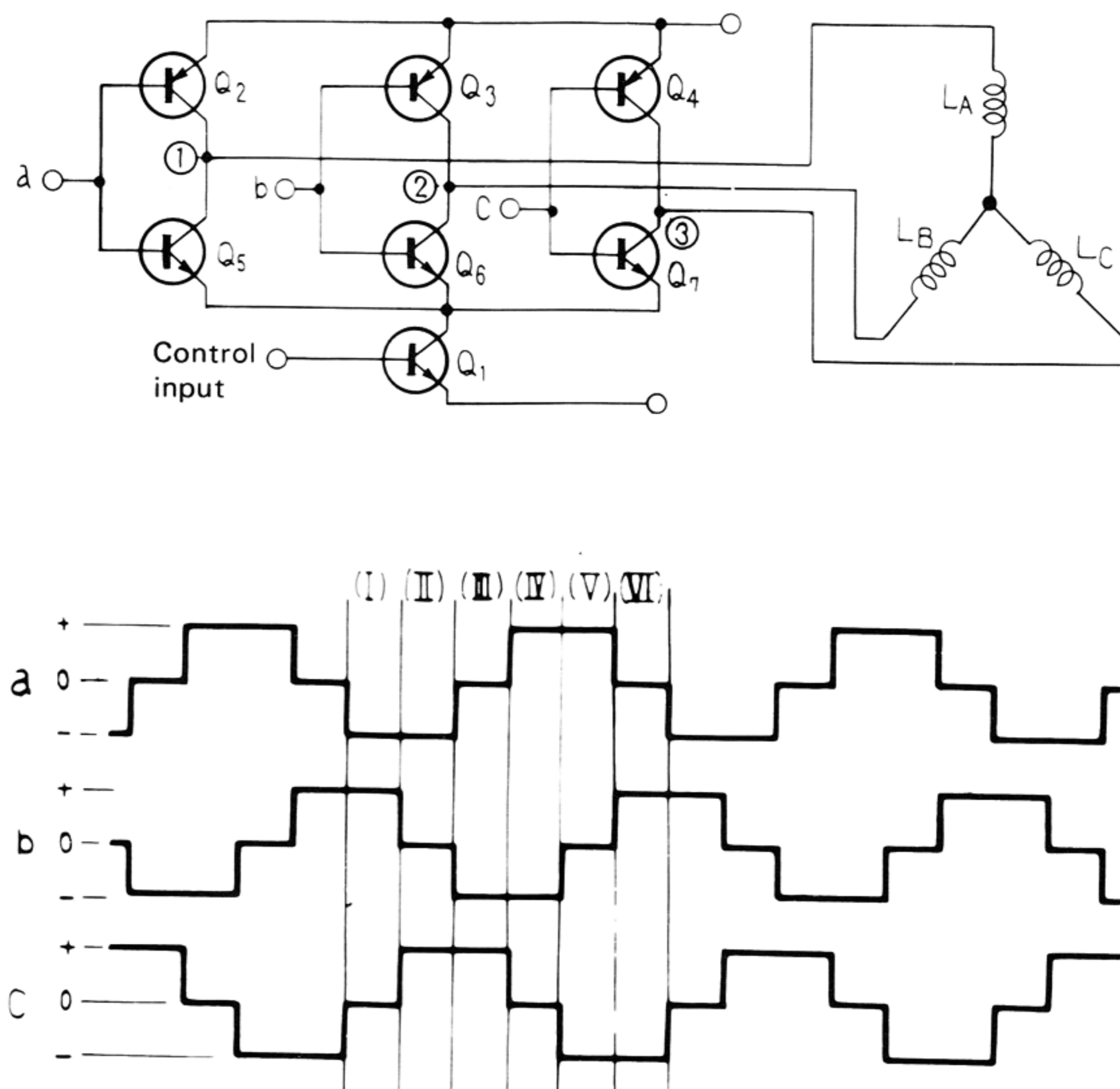

Fig. 18

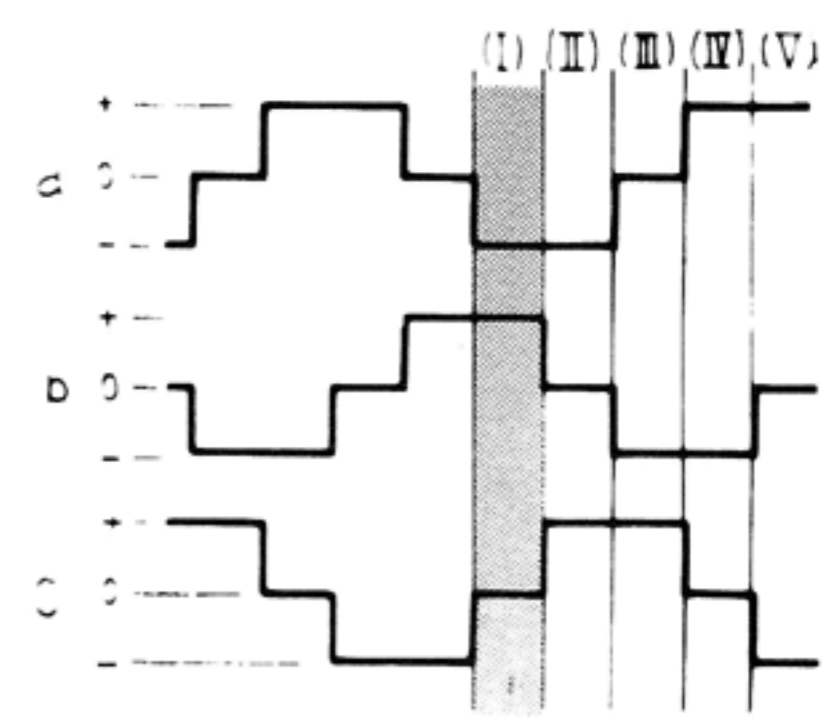
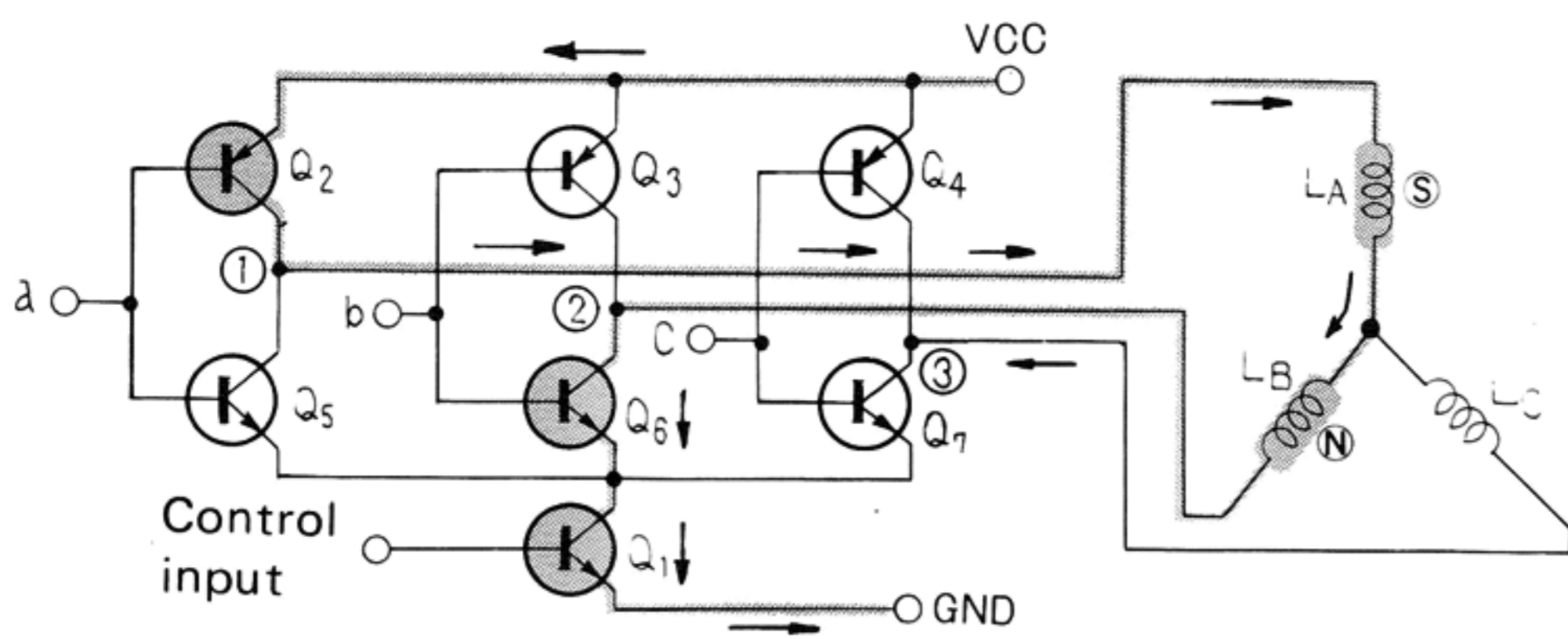

Fig. 19-a

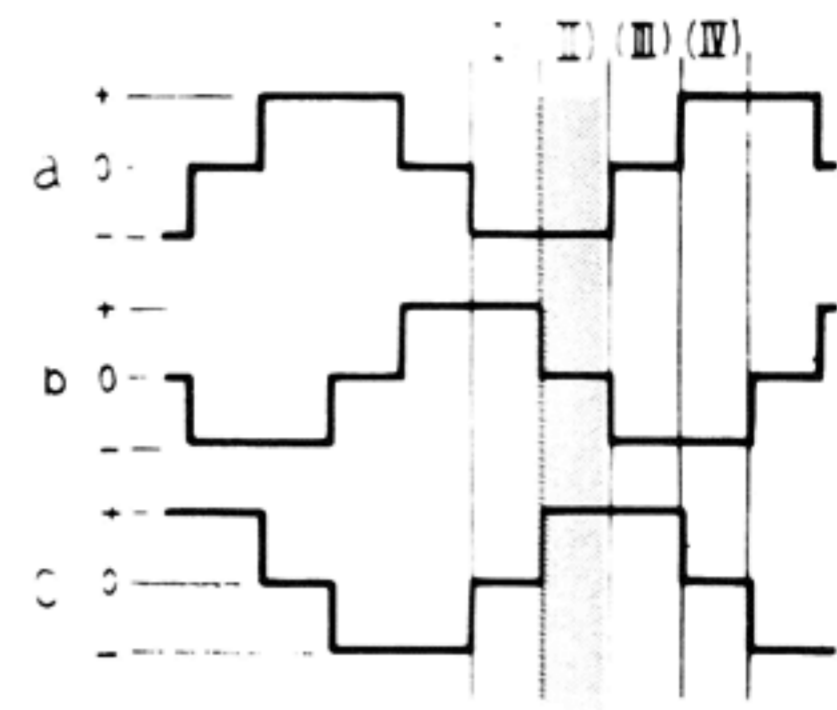
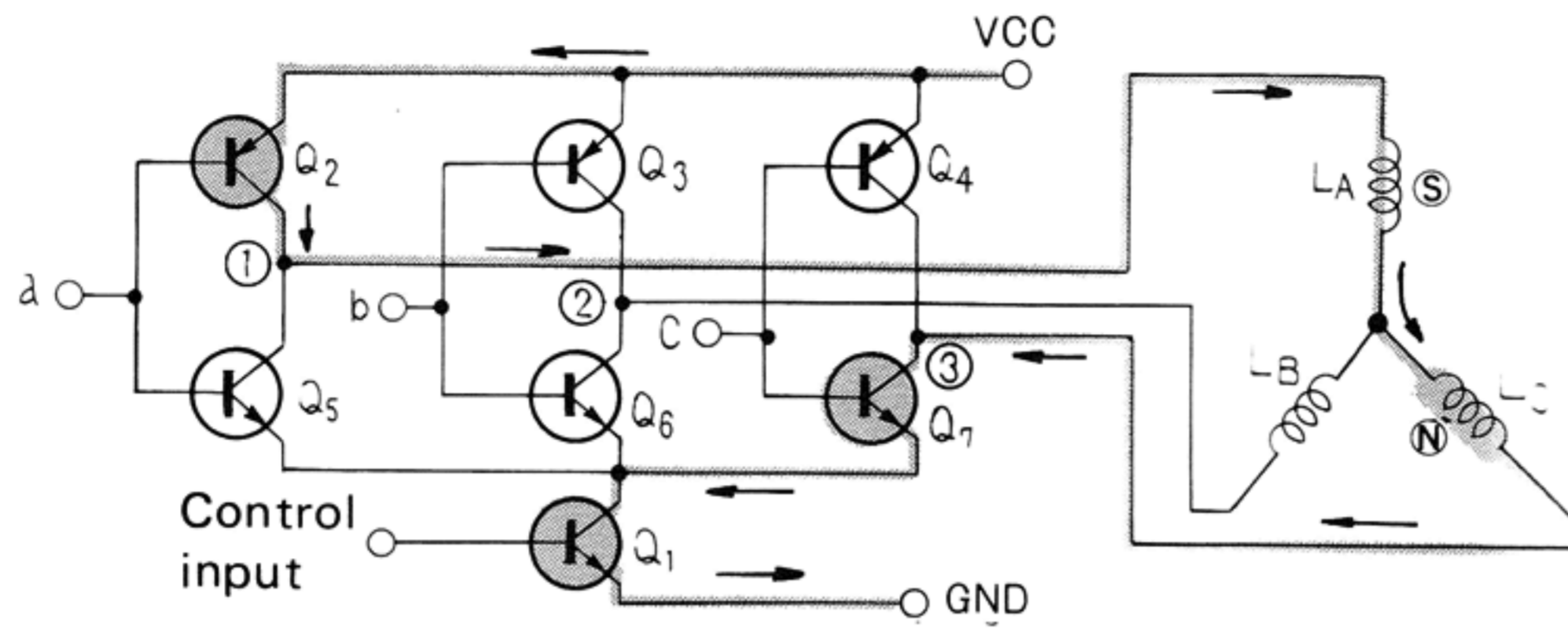

Fig. 19-b

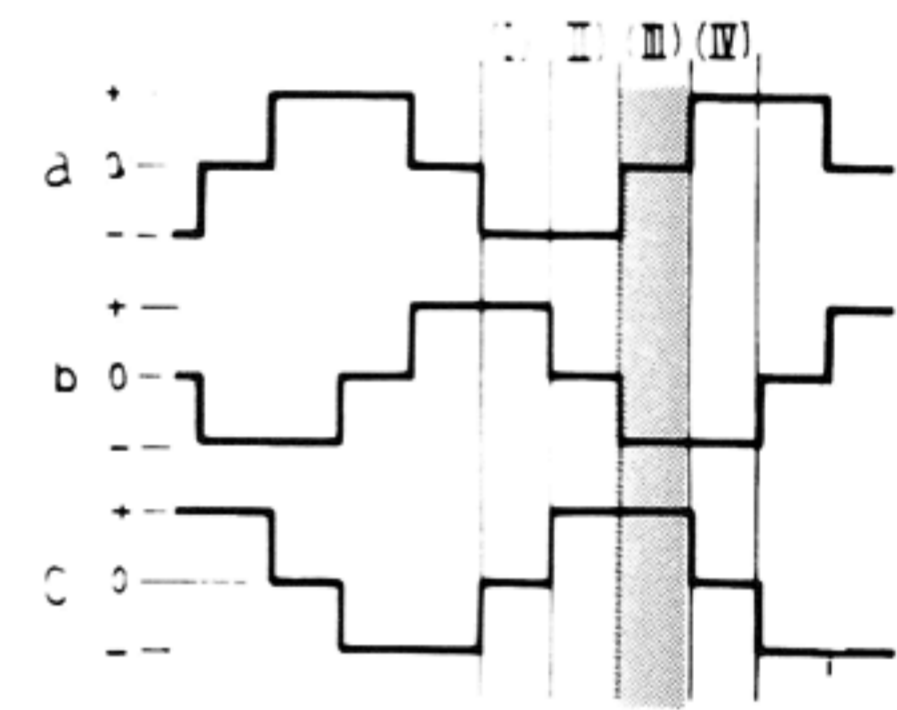
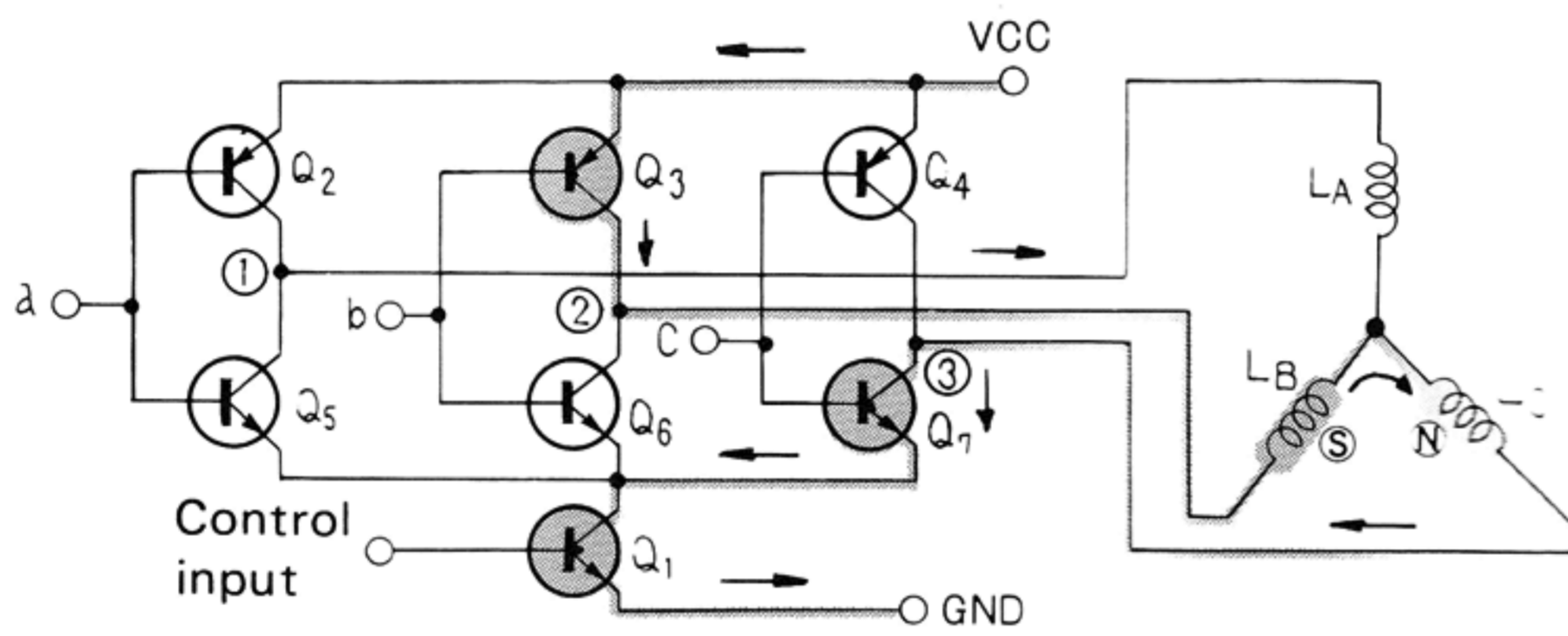

Fig. 19-c

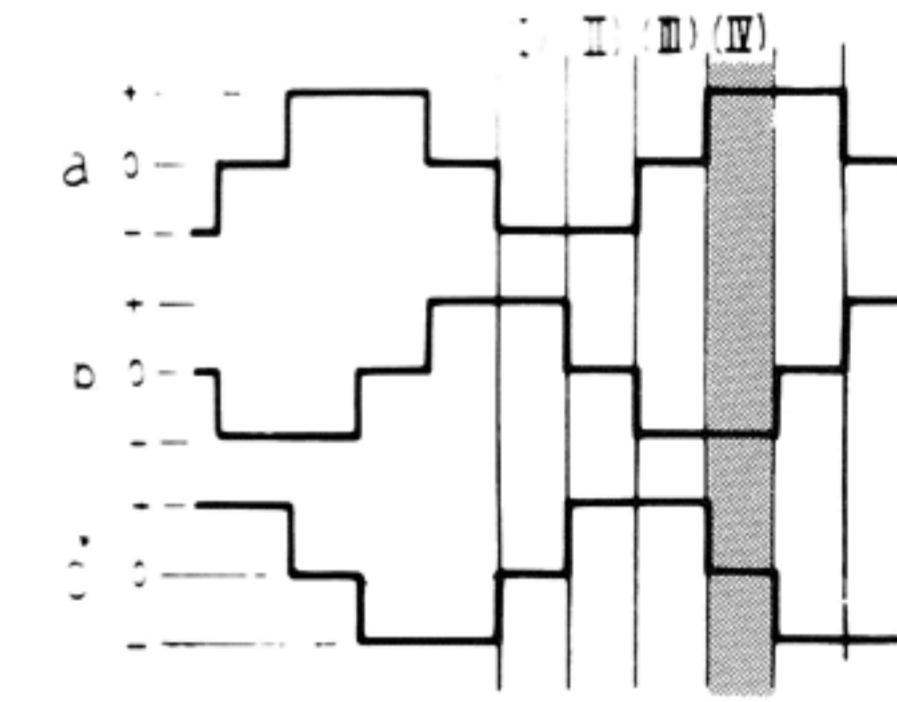
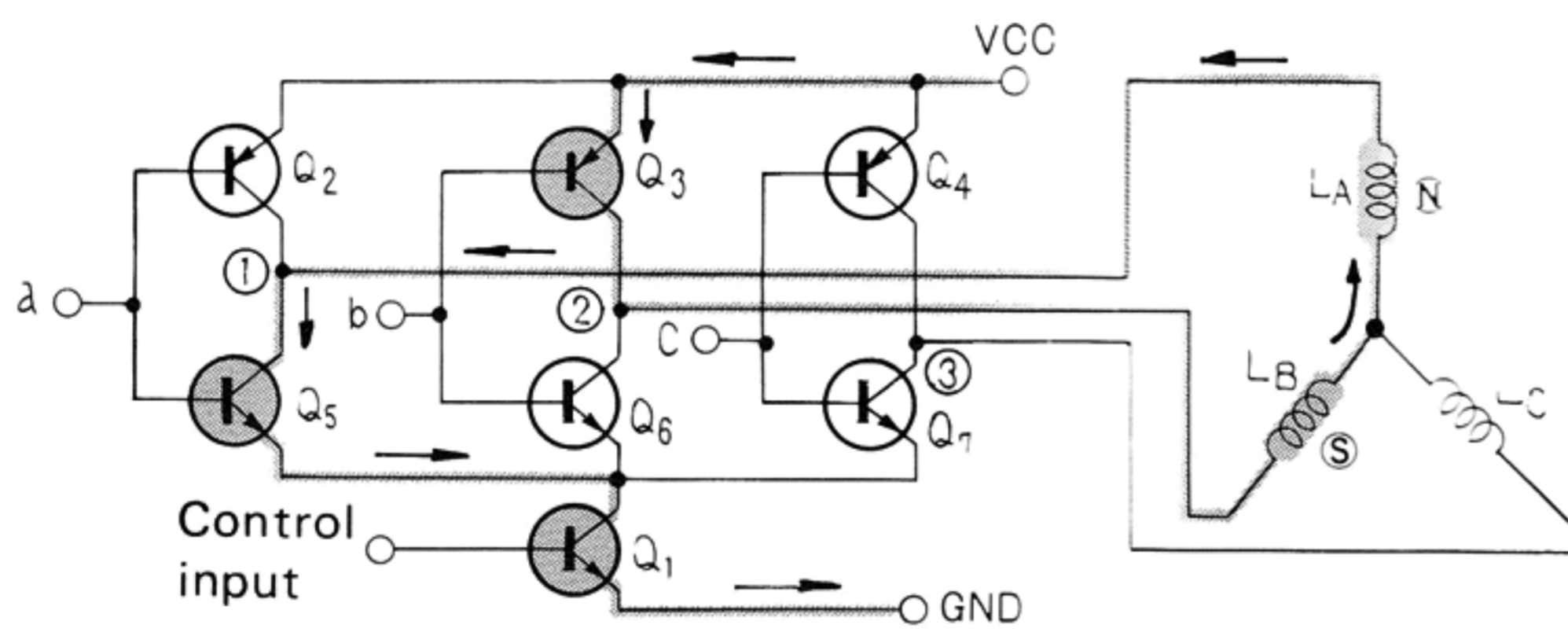

Fig. 19-d

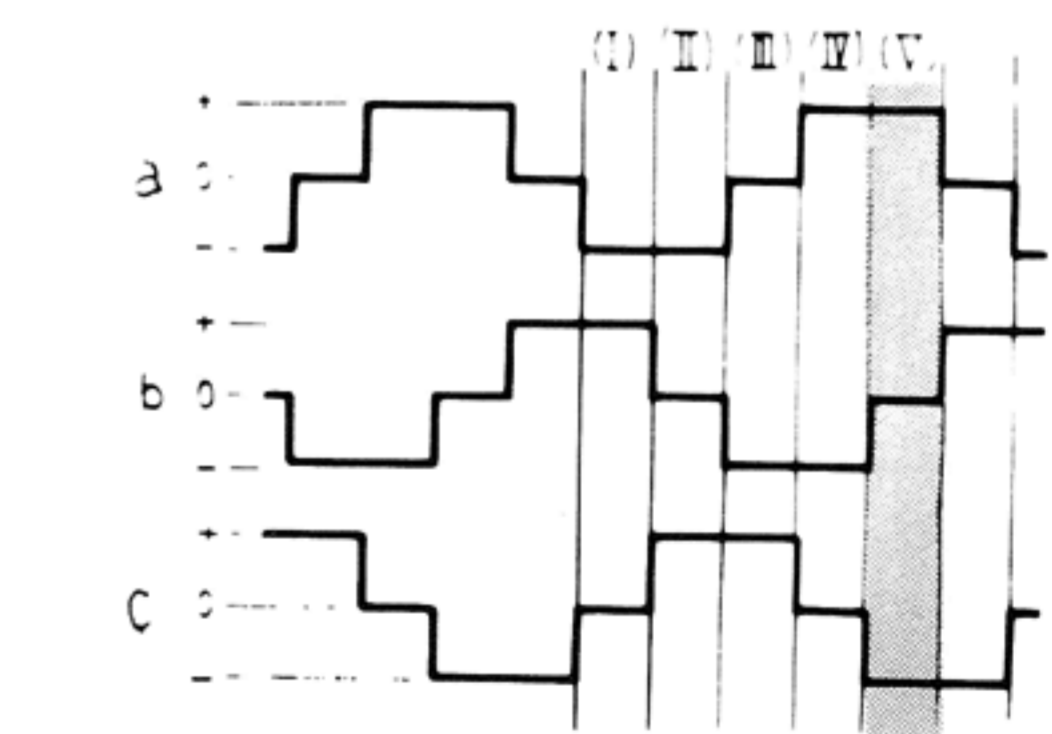
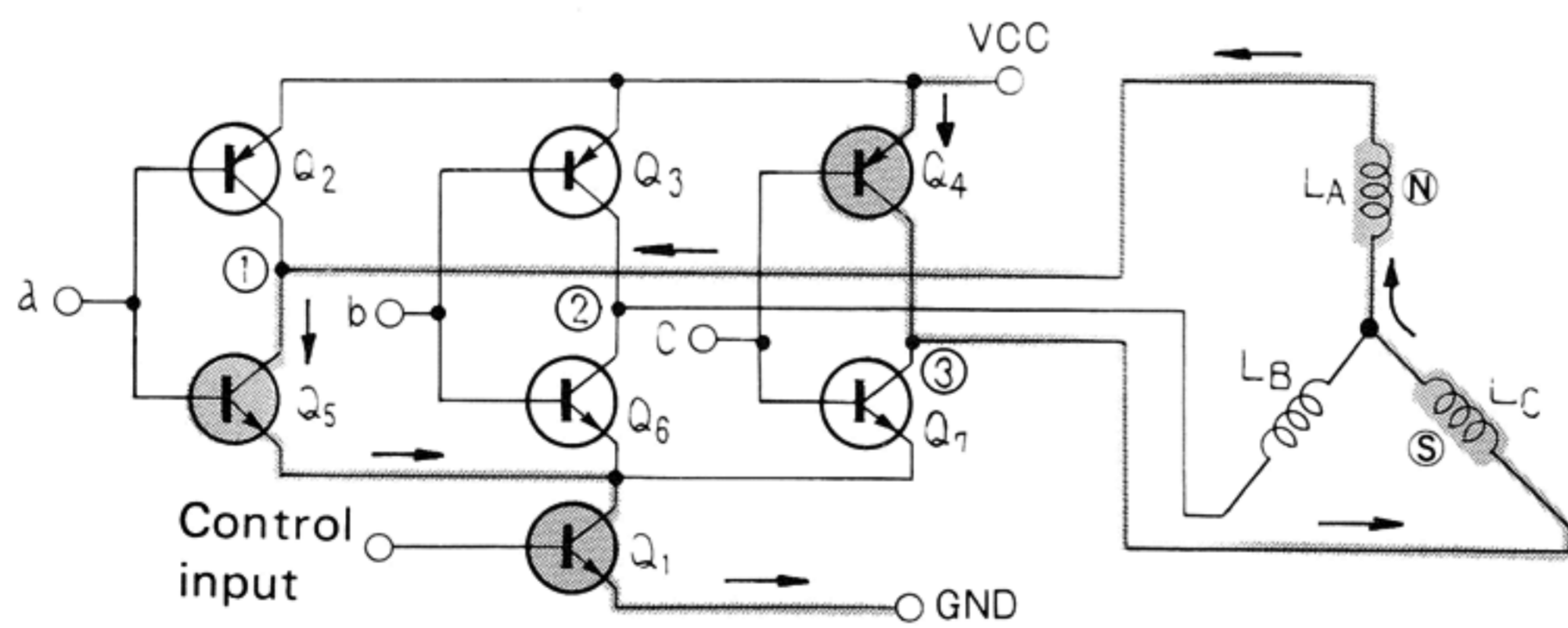

Fig. 19-e

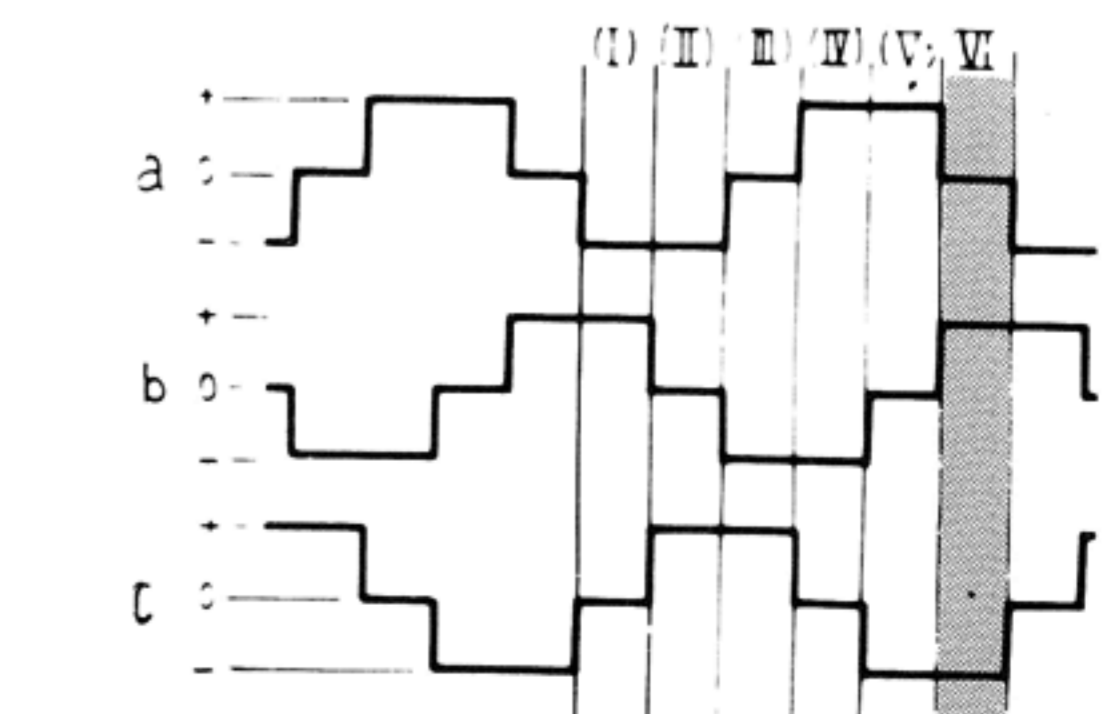
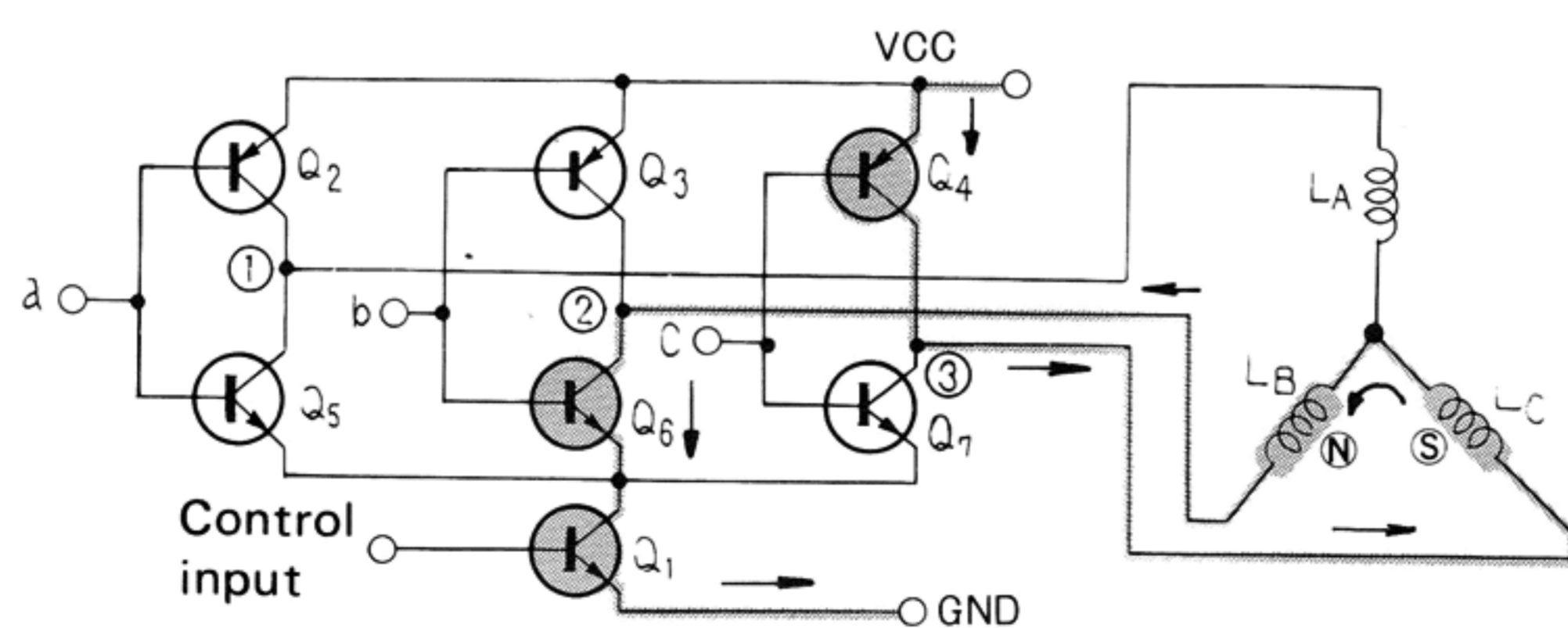
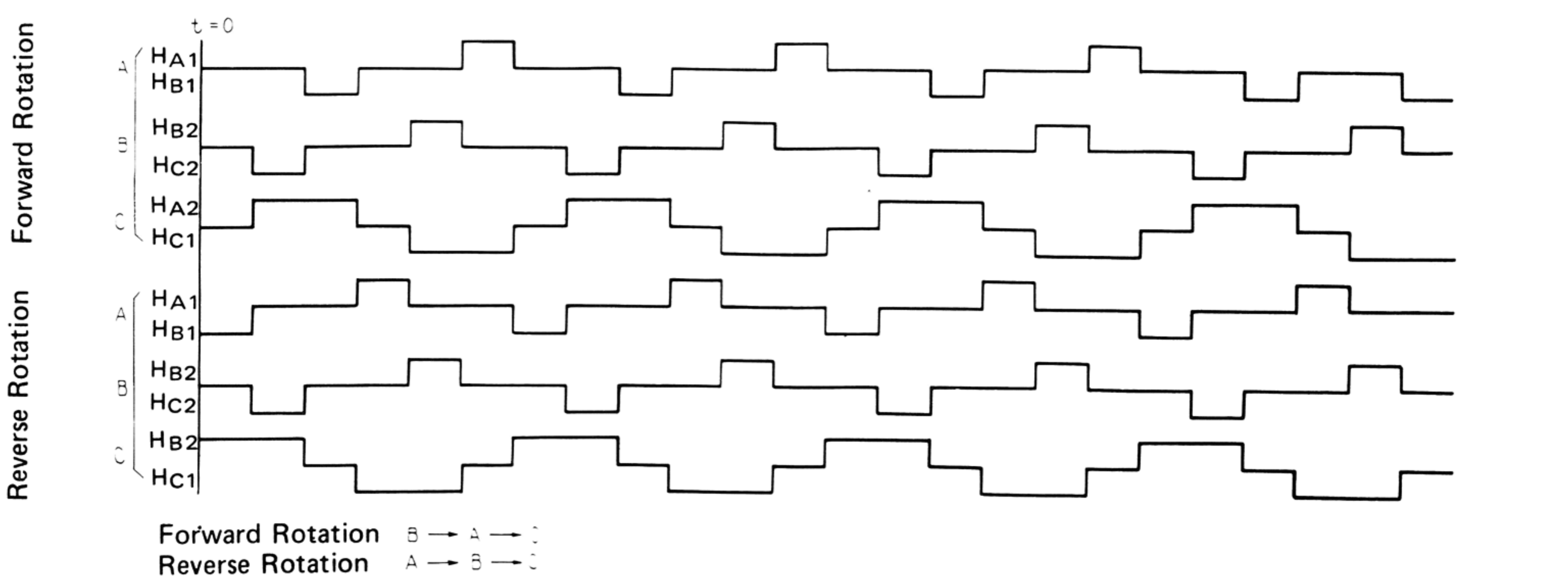
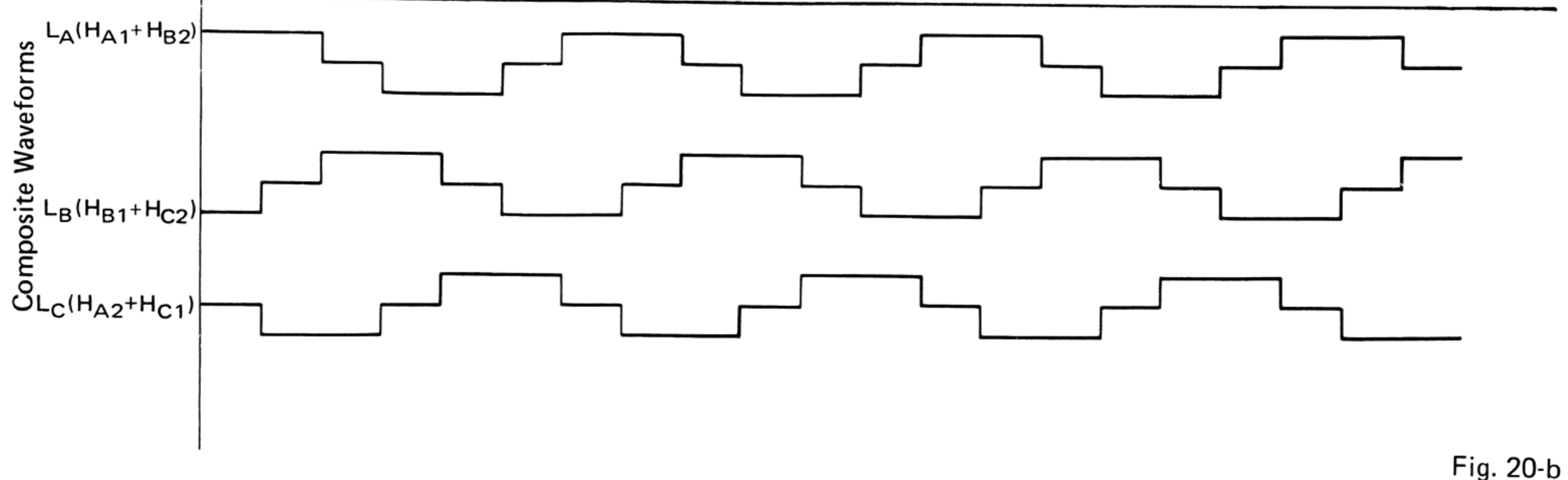
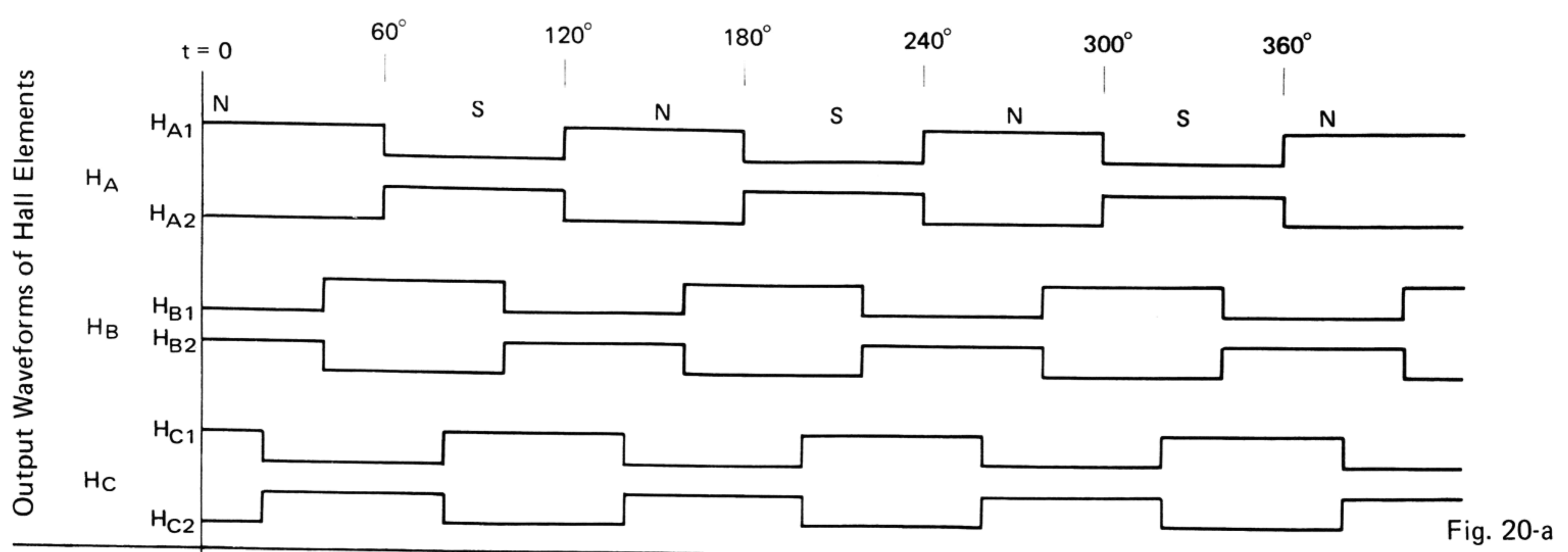
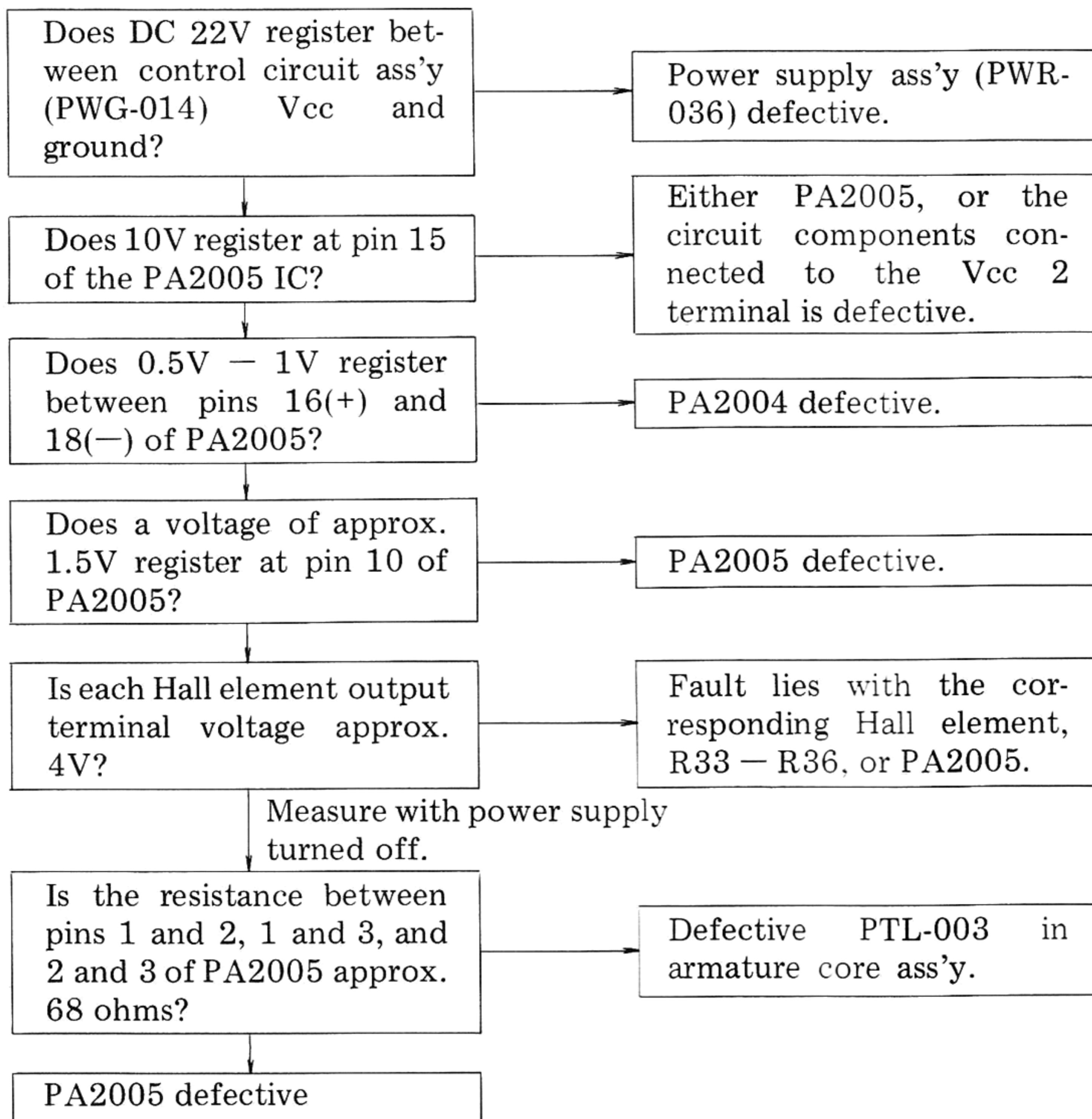

Fig. 19-f



6.6 TROUBLE SHOOTING CHART

1. When Motor Fails to Rotate



2. Phase Lock Failure

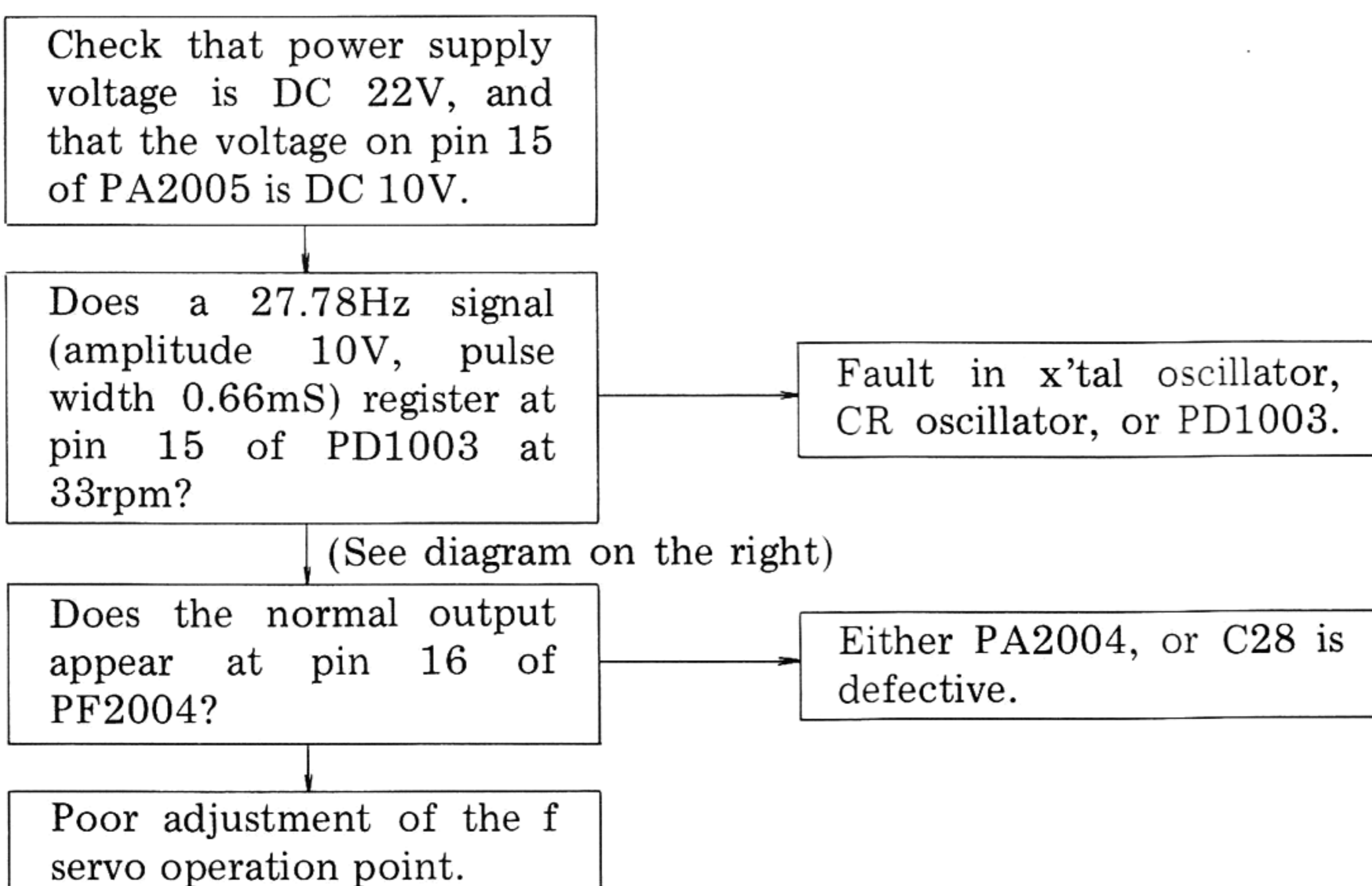

3. Motor Runaway

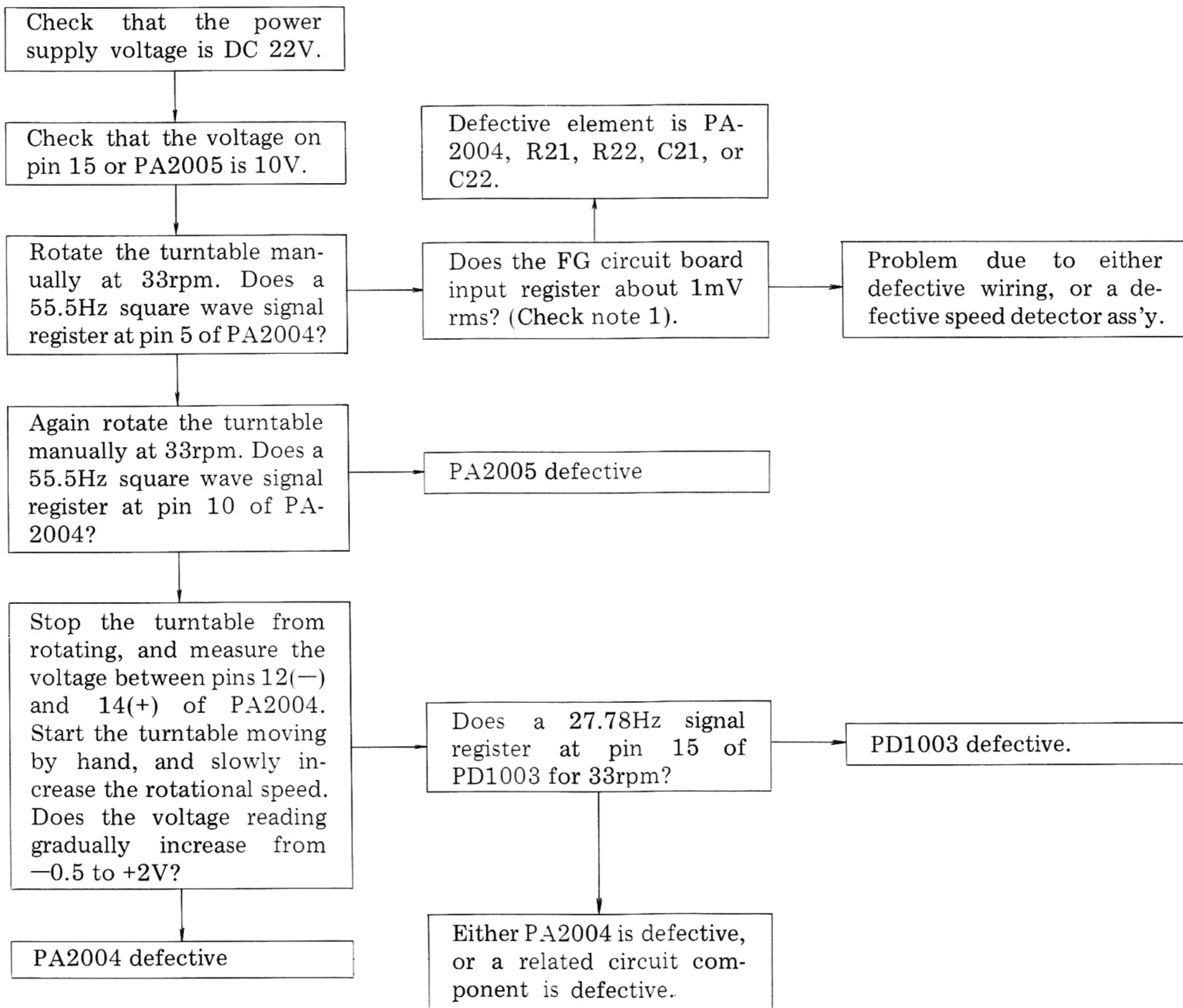

*Note 1. Connect a 100 μ V/10V capacitor between TP22 and ground.

6.7 MOTOR ADJUSTMENTS

● Adjustment Conditions

Connect the input terminals of a dual-image synchronized oscilloscope to the SP and TP23 terminals of the control circuit ass'y (PWG-014). Start up the turntable with the Quartz Lock control on.

● Adjustment Procedure

1. Monitor the output waveforms of terminals SP and TP23 (see Fig. 13).

(There should be 2 pulses in the TP23 output signal for every SP output signal).

2. Adjust the semi-fixed resistors in the control circuit ass'y (PWG-014) so that the upstroke of the TP23 output pulse signal lies within the pulse width of the SP output pulse signal.

For 33rpm VR21

For 45rpm VR22

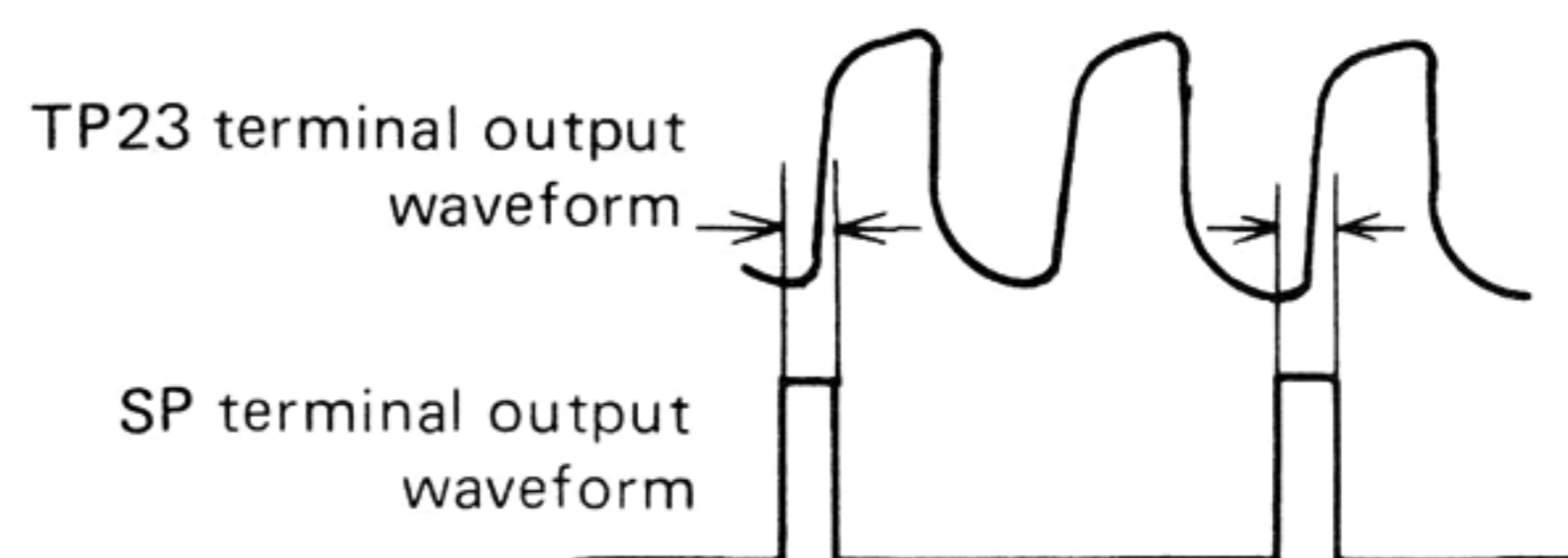

7. EXPLODED VIEWS

7.1 CABINET

NOTE: marked parts cannot be supplied.

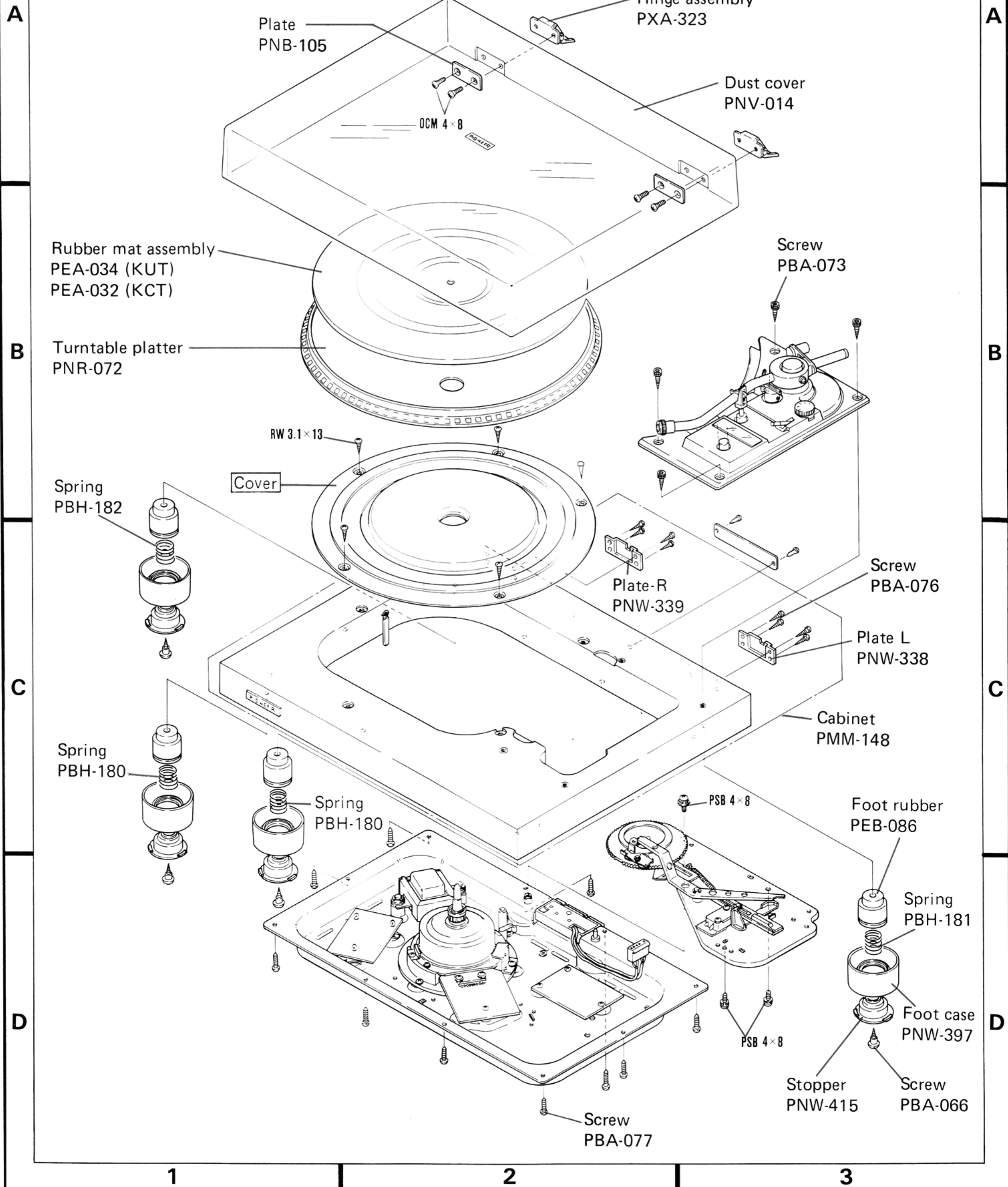

7.2 TONEARM

NOTE: Spring marked parts cannot be supplied.

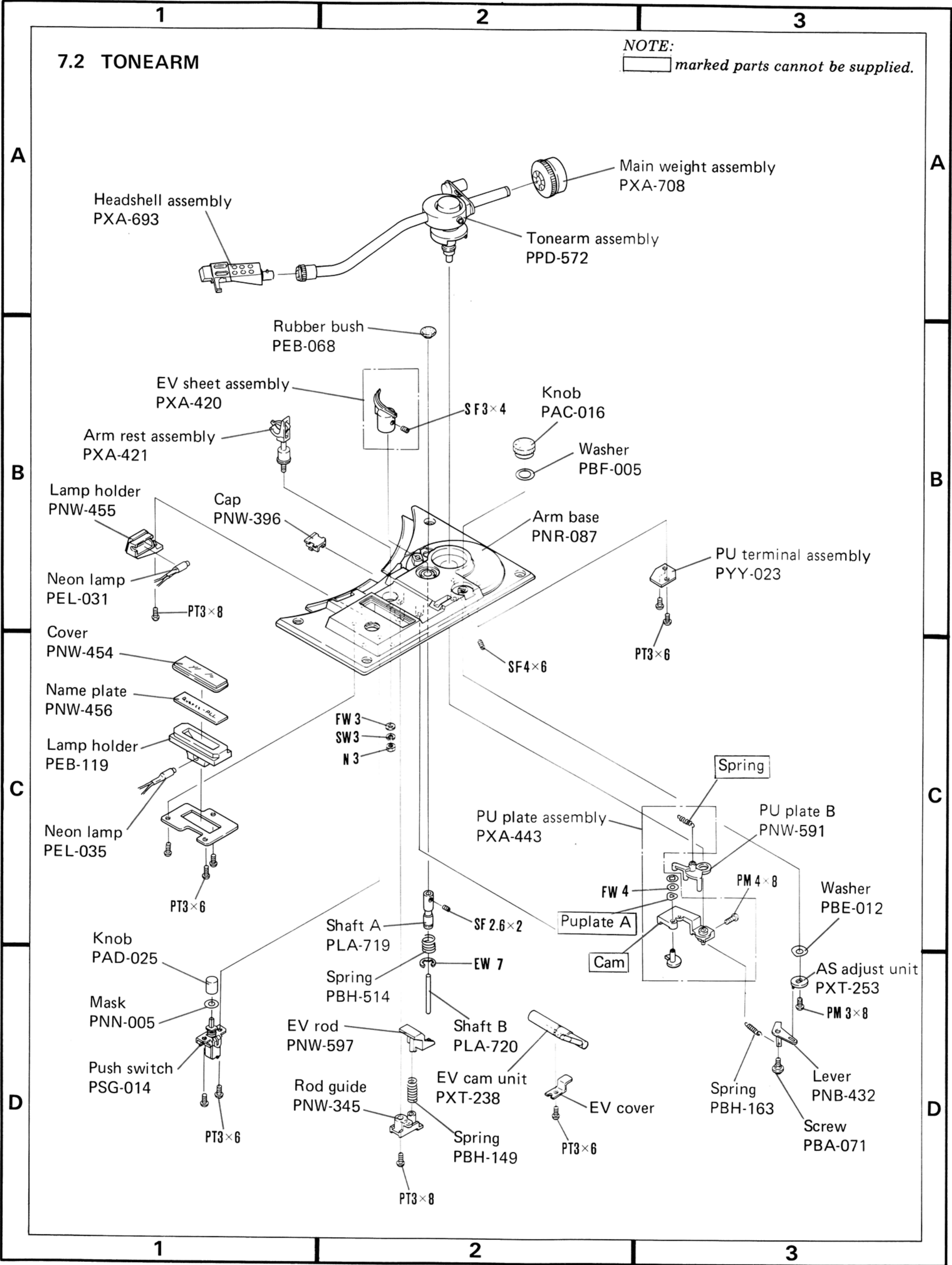

7.3 BOTTOM PLATE

NOTE: marked parts cannot be supplied.

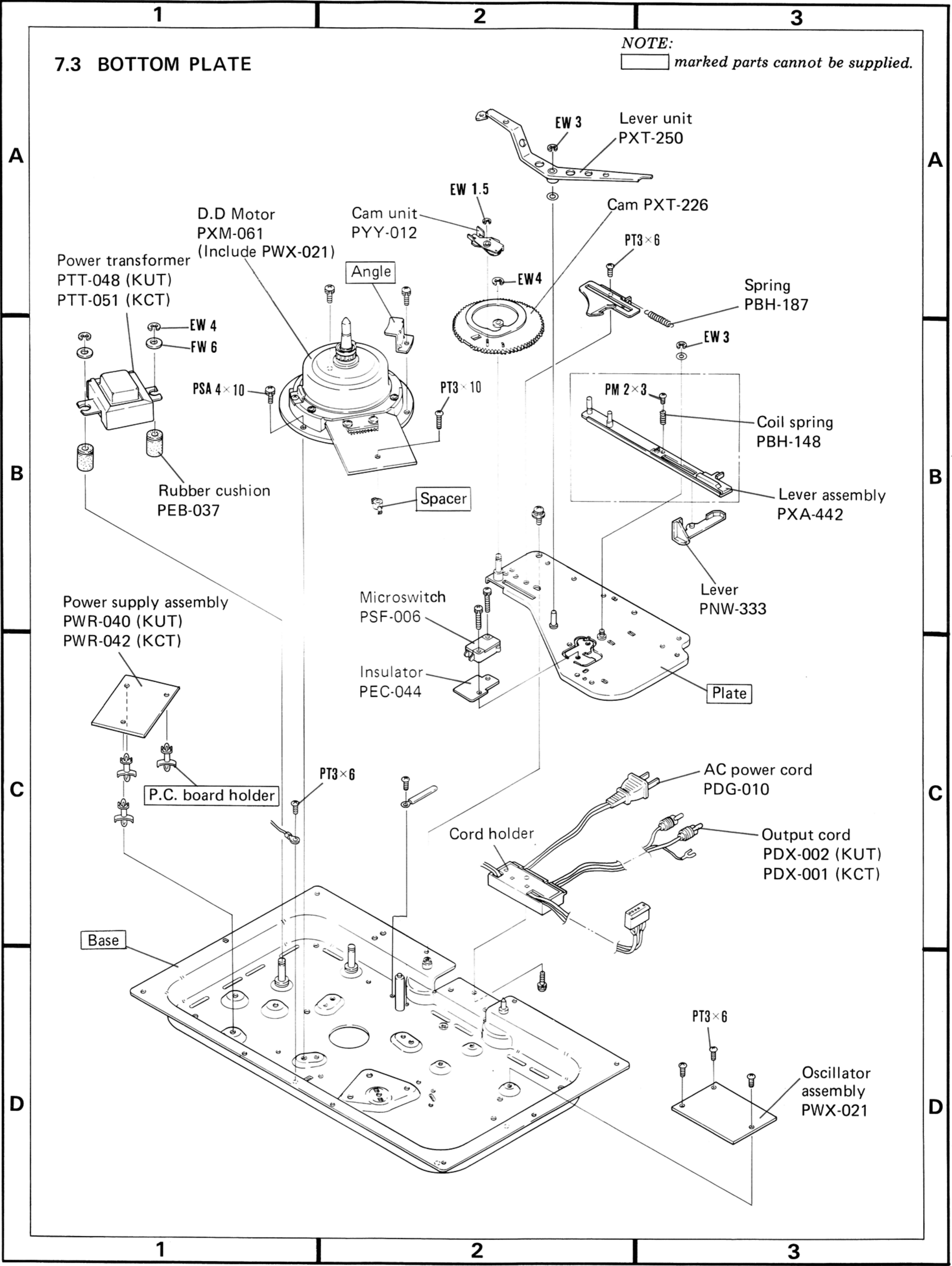

7.4 D.D. MOTOR (PXM-061)
 Include Oscillator Assembly PWX-021

NOTE:
 [] marked parts cannot be supplied.

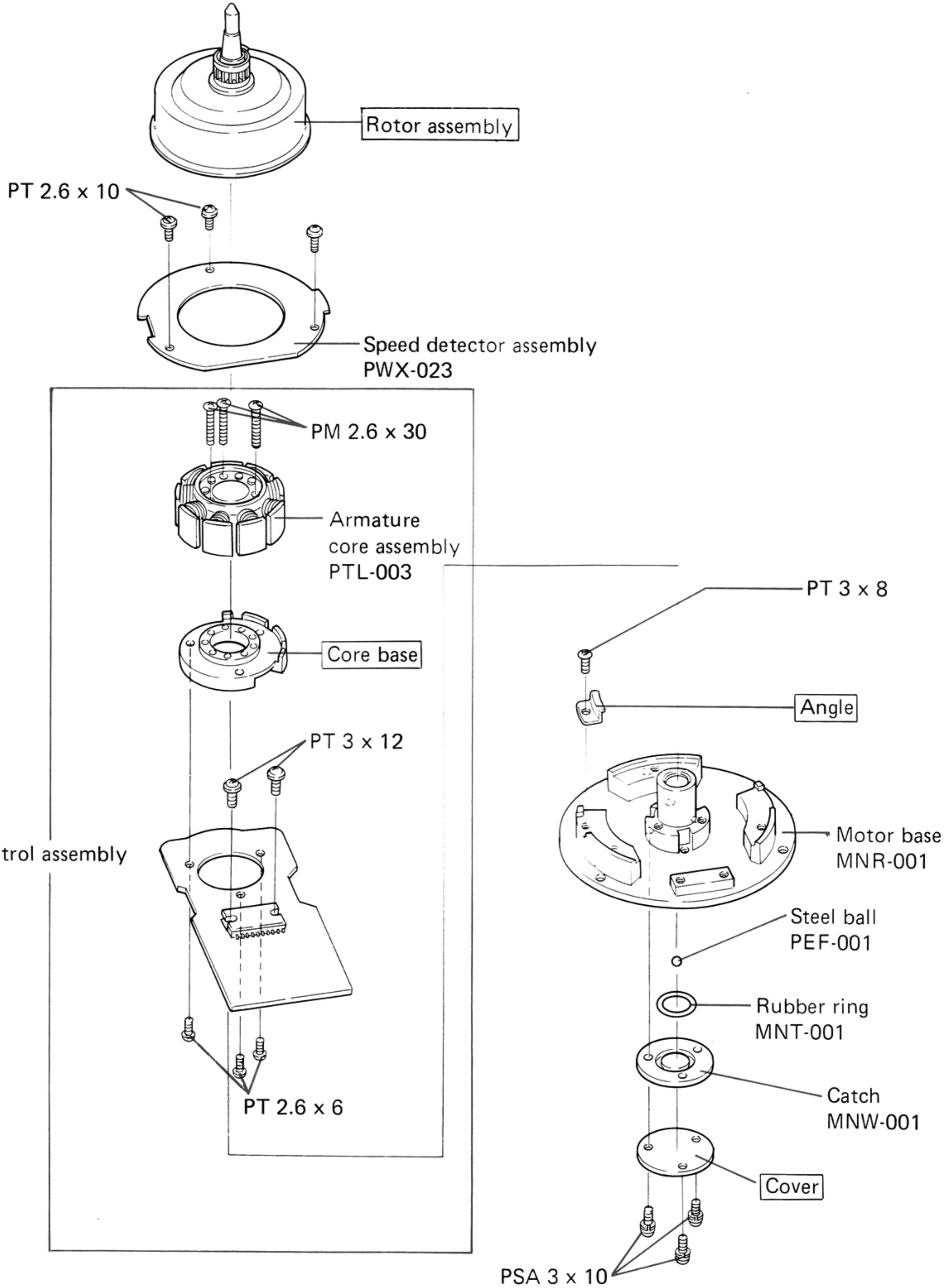

7.5 PACKING

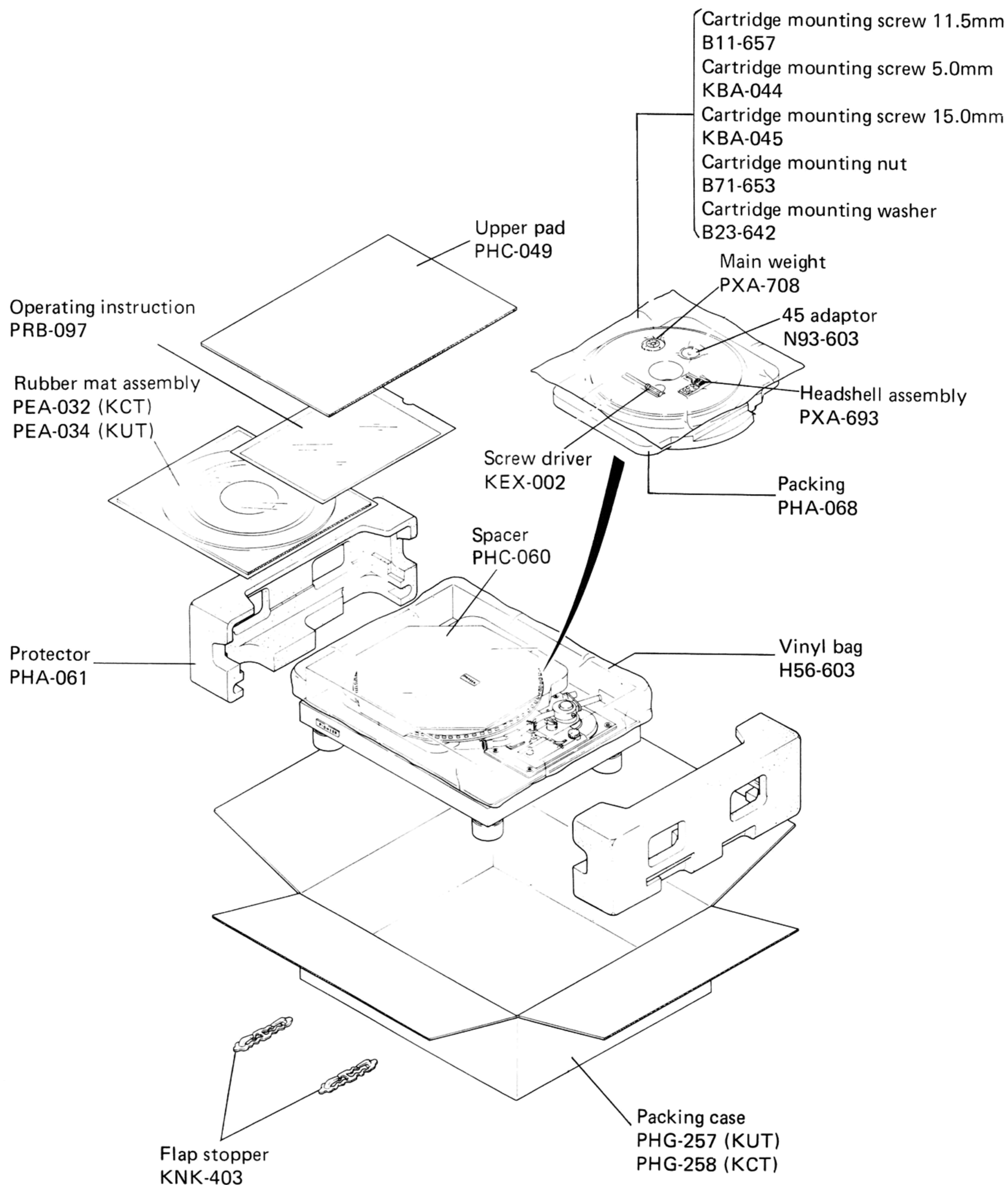

8. SCHEMATIC DIAGRAMS, P.C. BOARD PATTERNS AND PARTS LIST

NOTE:

- When ordering resistors, first convert resistance values into code form as shown in the following examples.

Ex. 1 When there are 2 effective digits (any digit apart from 0), such as 560 ohm and 47k ohm (tolerance is shown by J = 5%, and K = 10%).

560Ω — 56 × 10¹ — 561 RD¼PS 561 J
 47kΩ — 47 × 10³ — 473 RD¼PS 473 J
 0.5Ω — 0R5 RN2H 0R5 K
 1Ω — 010 RS1P 010 K

Ex. 2 When there are 3 effective digits (such as in high precision metal film resistors).

5.62kΩ 562 × 10¹ 5621 RN¼SR 5621 F

MISCELLANEOUS PARTS LIST

Parts List

<u>Part No.</u>	<u>Description</u>
PWX-021	Oscillator assembly
PWG-016	Drive control assembly
PWR-040 (KUT)	Power Supply assembly
PWR-042 (KCT)	Power Supply assembly
PSG-014	Speed selector
PEL-031	Neon lamp
PSF-006	Power switch
PTT-048 (KUT)	Power transformer
PTT-051 (KCT)	Power transformer
PDG-010	AC power cord

8.1 SCHEMATIC DIAGRAM



SWITCHES
 S₁: SPEED SELECTOR (rpm)
 33 1/3 - 45
 S₂: POWER OFF - ON
 The underlined indicates the switch position

RESISTORS
 IN OHM 1/4W 5% TOLERANCE UNLESS OTHERWISE NOTED
 K: kΩ M: MΩ

CAPACITORS
 IN μF UNLESS OTHERWISE NOTED p; pF

This is the basic schematic diagram, but the actual circuit may vary due to improvements in design.

Note 1. When measuring the waveform at (E), connect a 100μF/10V capacitor between TP22 and ground.

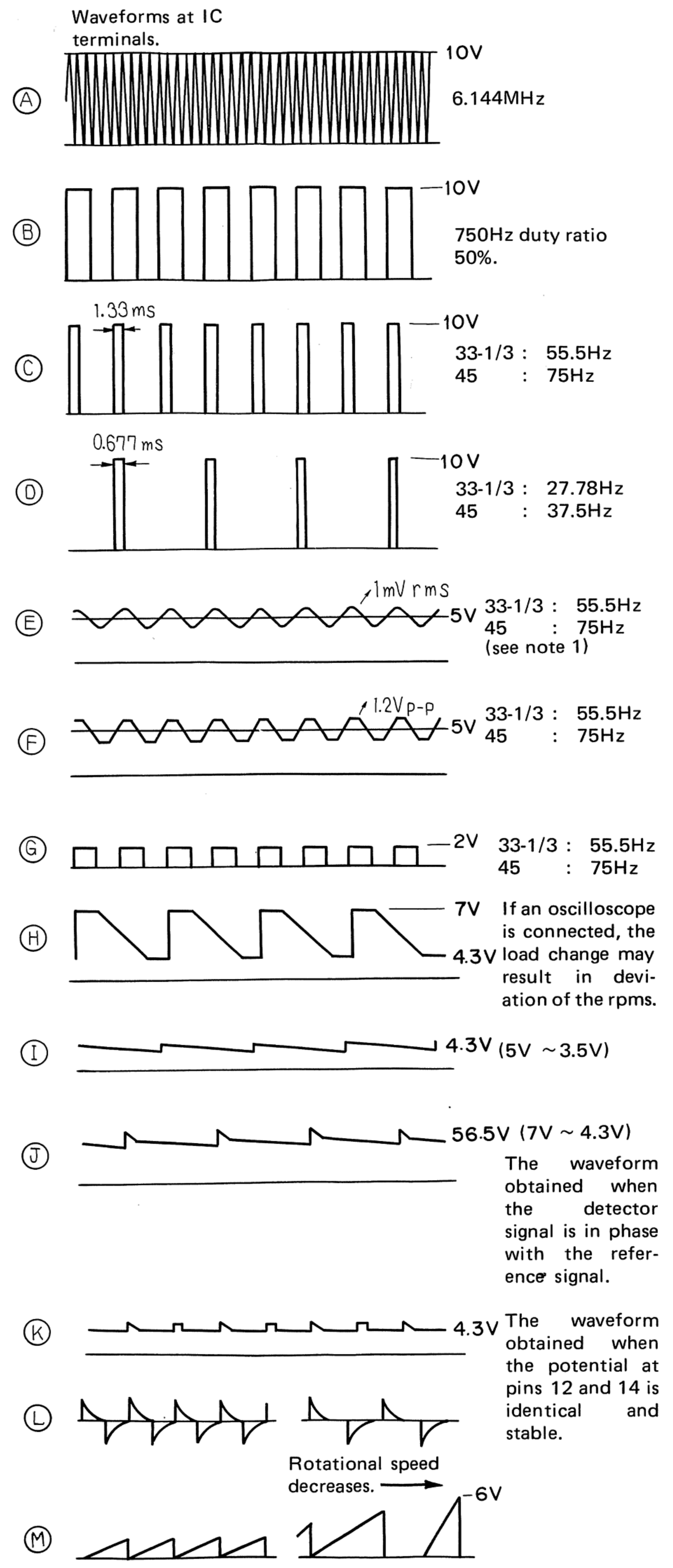

8.2 P.C. BOARD CONNECTION DIAGRAM

Power Supply
Assembly PWR-042 (KCT),
PWR-040 (KUT)

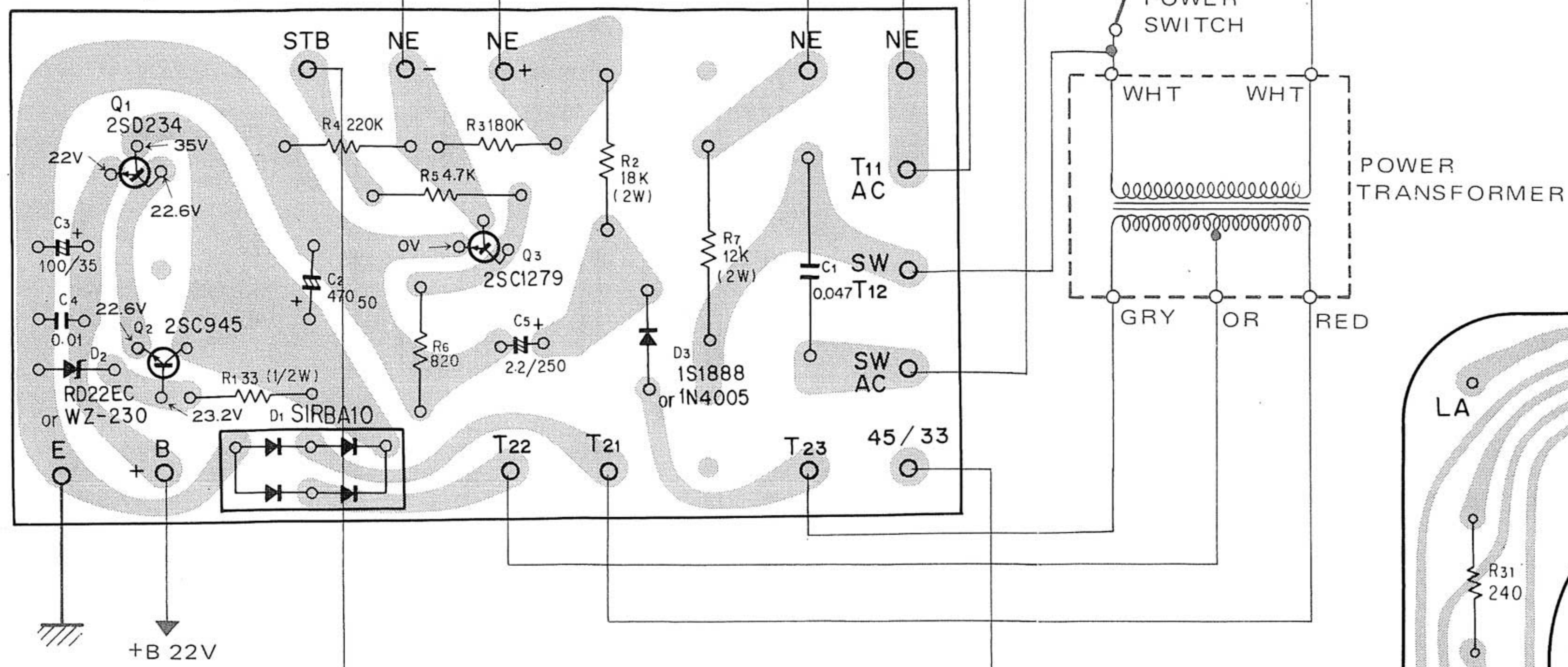

Armature Core
Assembly PTL-003

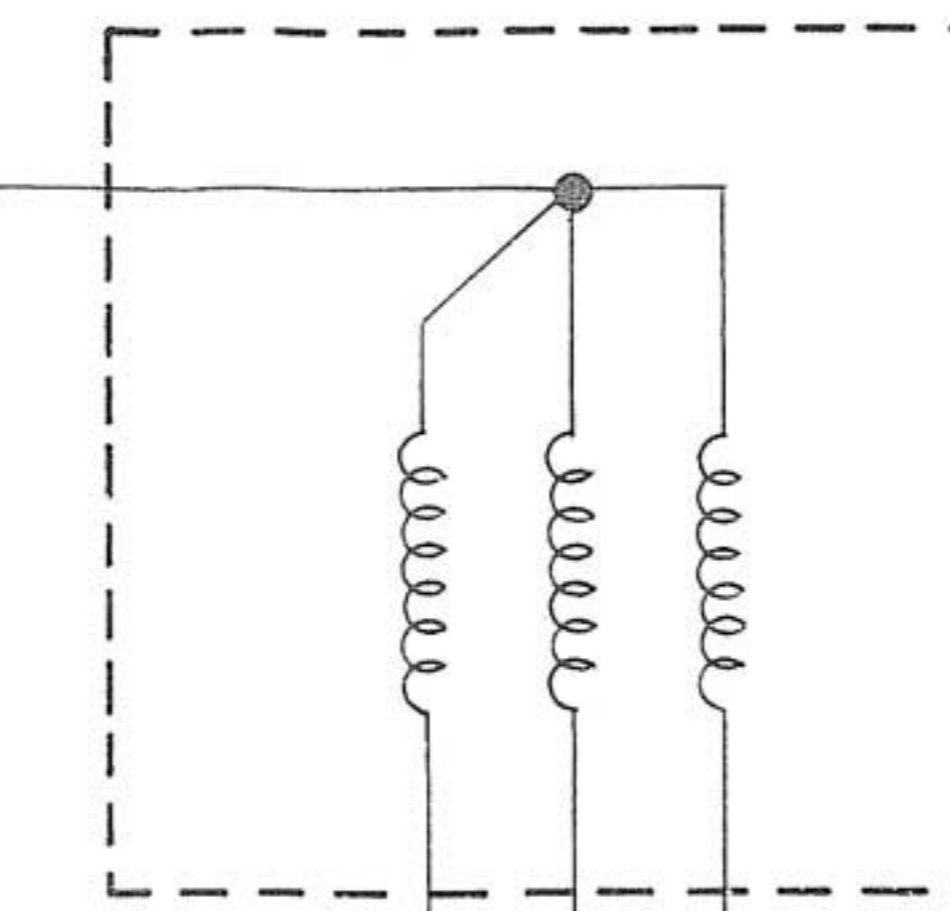

Speed Detector
Assembly PWX-023

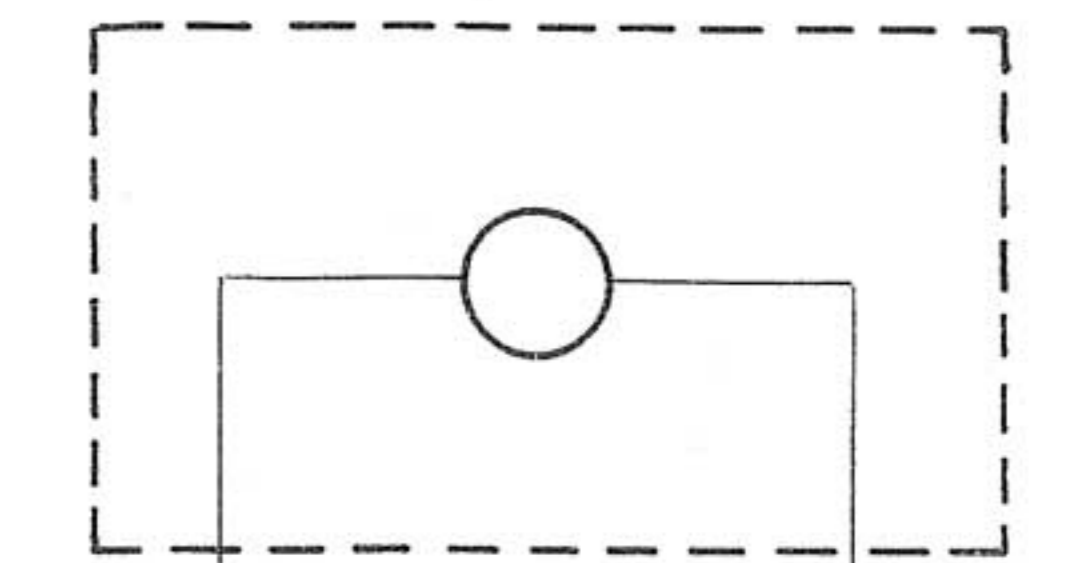

Drive Control
Assembly PWG-016

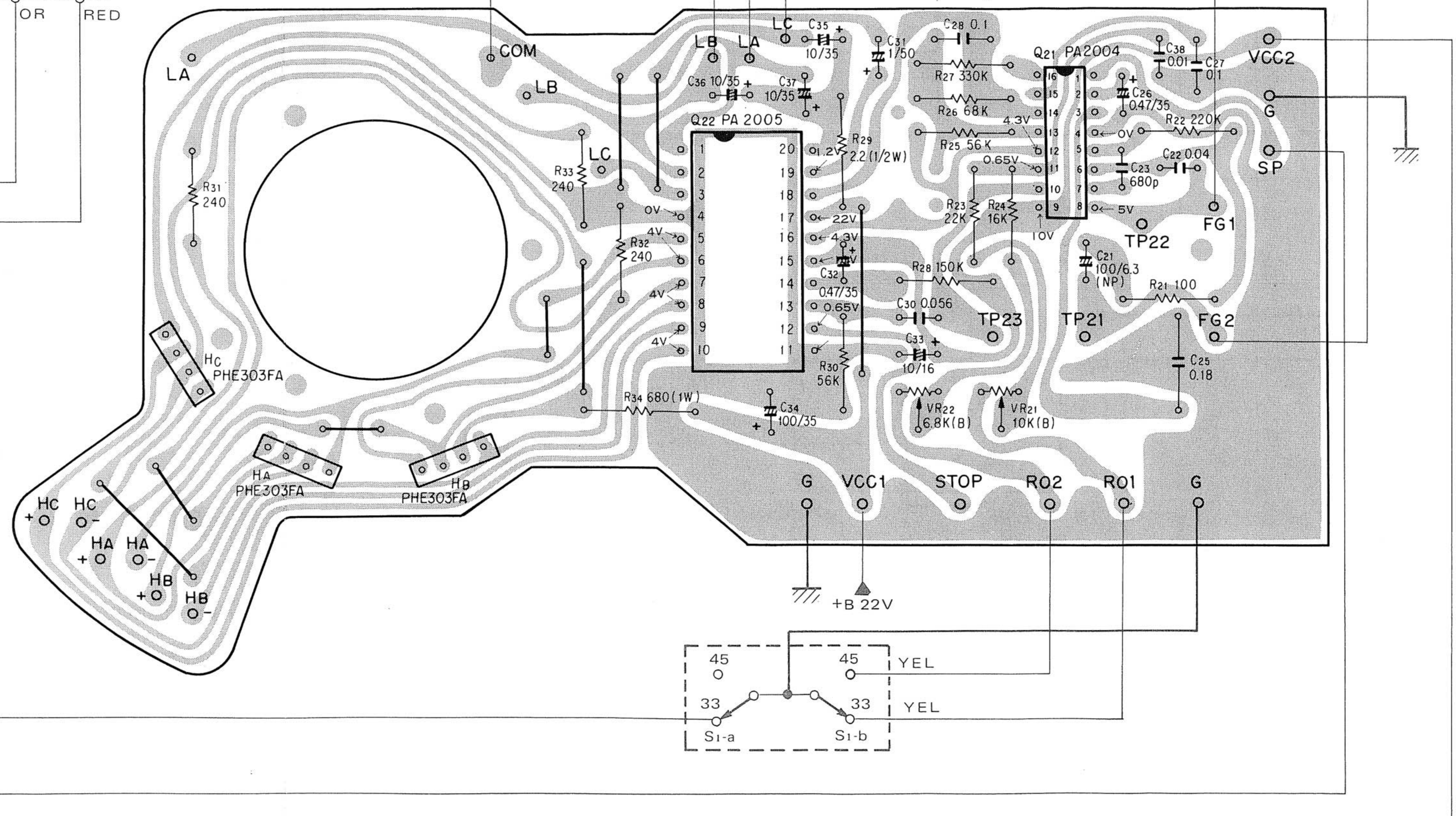

O.S.C. Assembly PWX-021

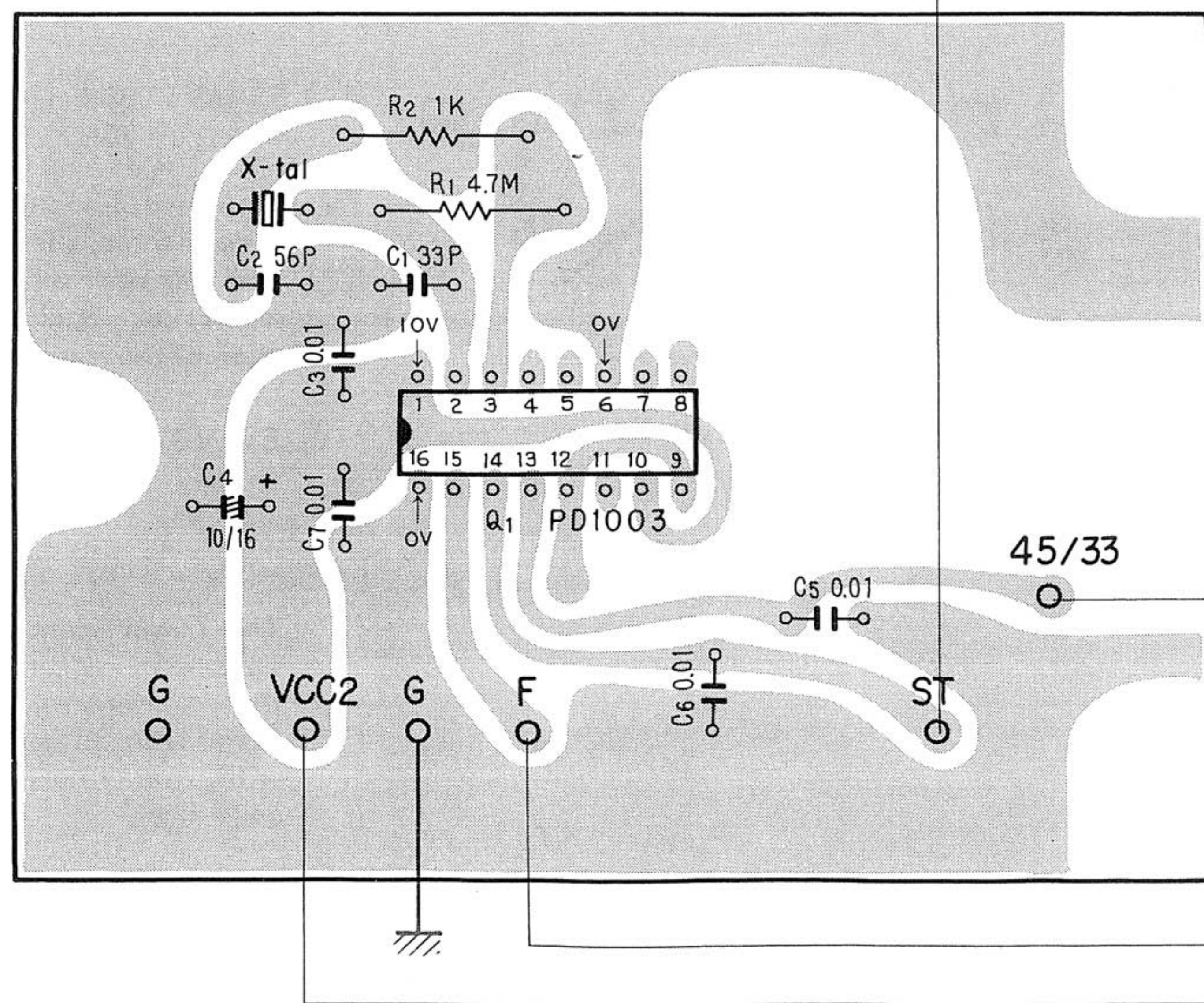

8.3 DRIVE CONTROL ASSEMBLY (PWG-016)
 Include Armature Core Assembly (PTL-003)

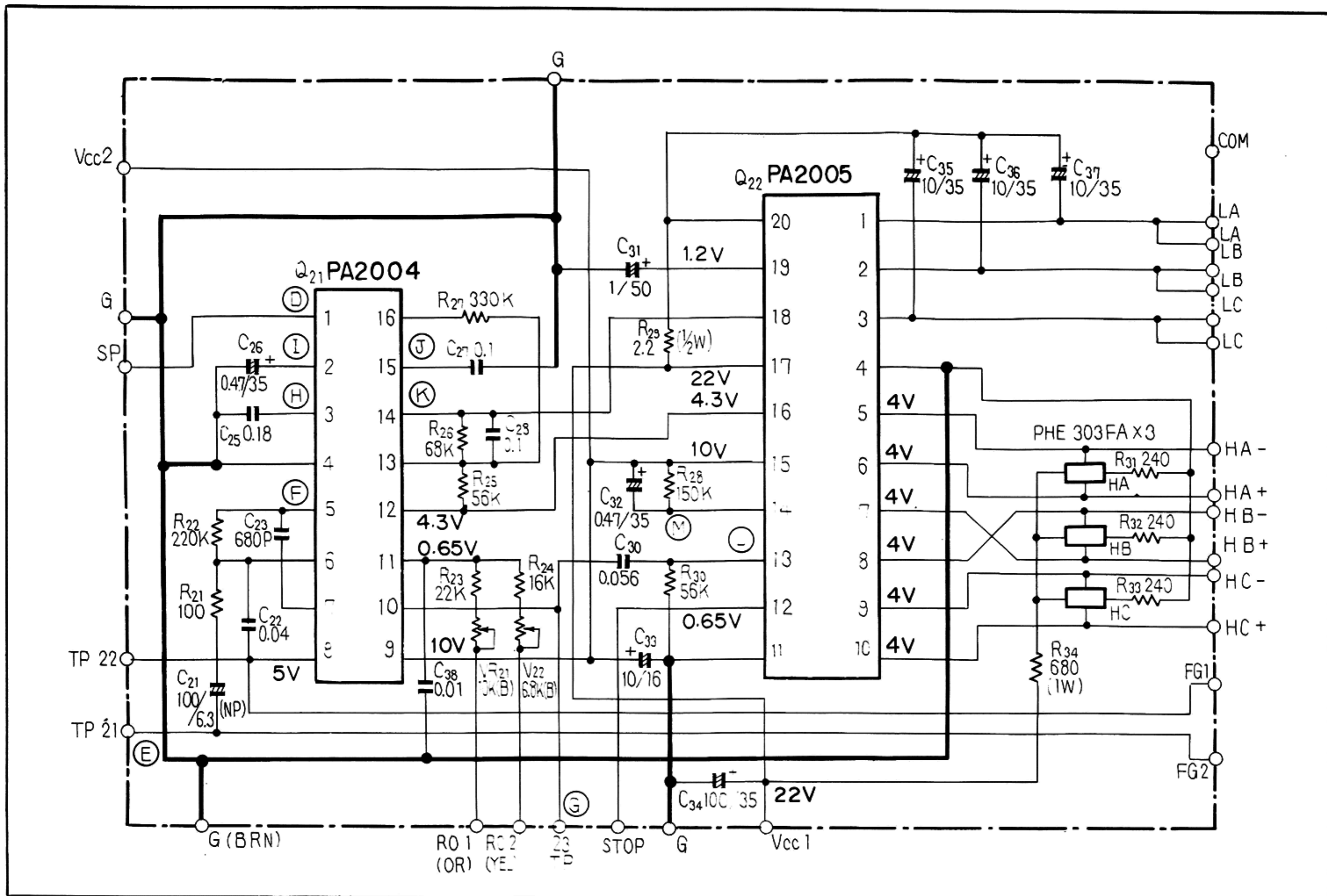

Parts List of Drive Control Assembly (PWG-016)

Note: When ordering resistors, convert the resistance value into code form, and then rewrite the part no. as before.

CAPACITORS

Part No.	Symbol & Description
CEA 101M 6.3NP	C21
CKDYF 403Z 50	C22
CKDYB 681K 50	C23
CQMA 184J 50	C25
CSZA R47K 35	C26
CQMA 104J 50	C27
CQMA 104K 50	C28
CQMA 563K 50	C30
CEA 010P 50	C31
CSZA R47K 35	C32
CSZA 100K 16	C33
CEA 101P 35	C34
CEA 100P 35	C35-C37
CKDYF 103Z 50	C38

RESISTORS

Part No.	Symbol & Description
PCP-018	VR21 Semi-fixed 10k-B
PCP-017	VR22 Semi-fixed 6.8k-B
RD¼PS □□□J	R21-R28, R30-R33
RD½PS □□□J	R29
RS1P □□□J	R34

SEMICONDUCTORS

Part No.	Symbol & Description
PA2004	Q21
PA2005	Q22
PCX-039	HA, HB, HC Hall element
PTL-003	Armature core Assembly

8.4 OSCILLATOR ASSEMBLY (PWX-021)

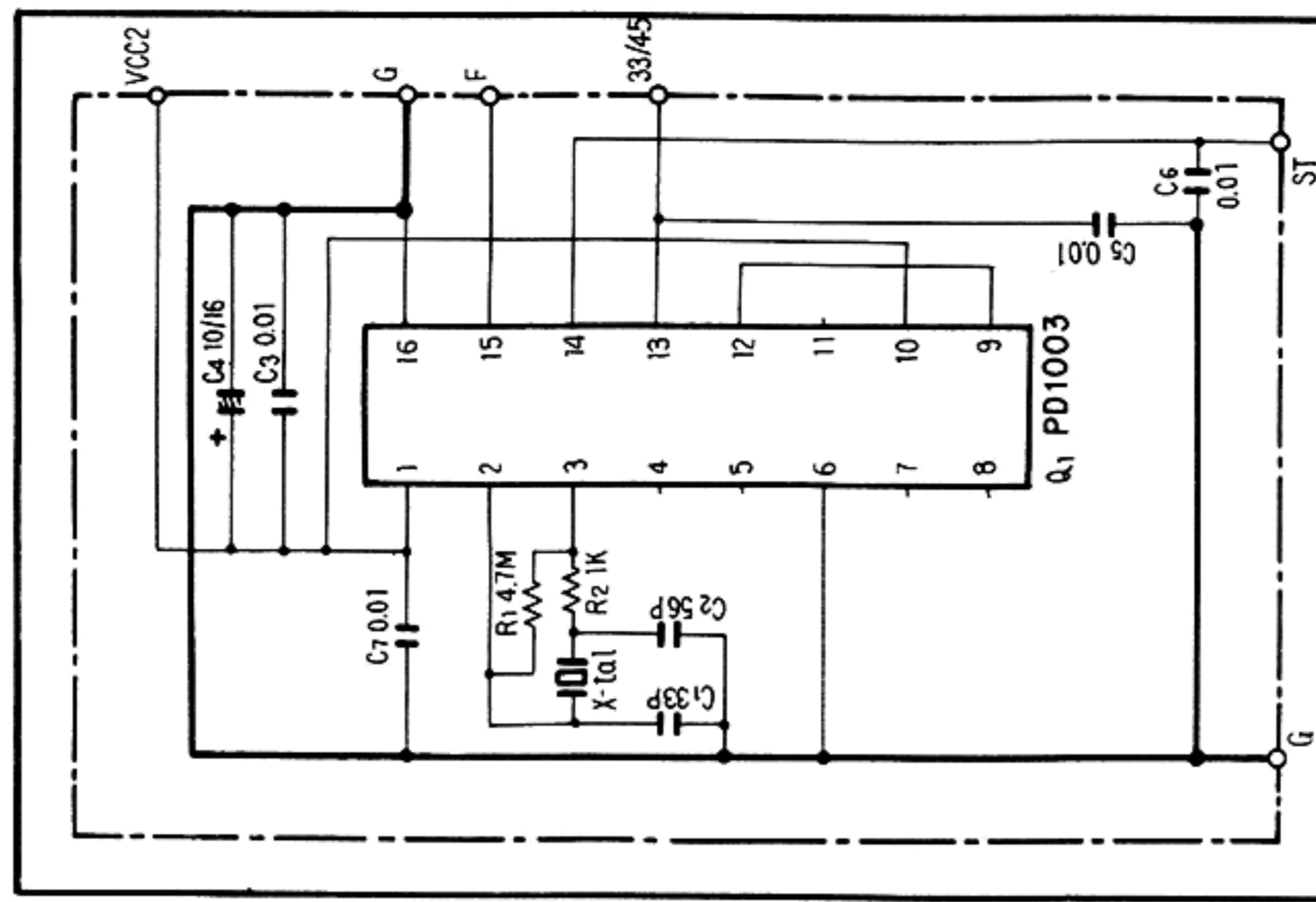

Parts List of Oscillator Assembly (PWX-021)

CAPACITORS

Part No.	Symbol & Description
CCDCH 330J 50	C1
CCDCH 560J 50	C2
CKDYF 103Z 50	C3
CEA 100P 16	C4
CKDYF 103Z 50	C5, C6

RESISTORS

Part No.	Symbol & Description
RD1/4PS □□□J	R1, R2

SEMICONDUCTOR and OTHER

Part No.	Symbol & Description
PD1003	IC
PSS-003	Crystal

Note: When ordering resistors, convert the resistance value into code form, and then rewrite the part no. as before.

8.5 POWER SUPPLY ASSEMBLY (PWR-042 KUT) (PWR-040 KCT)

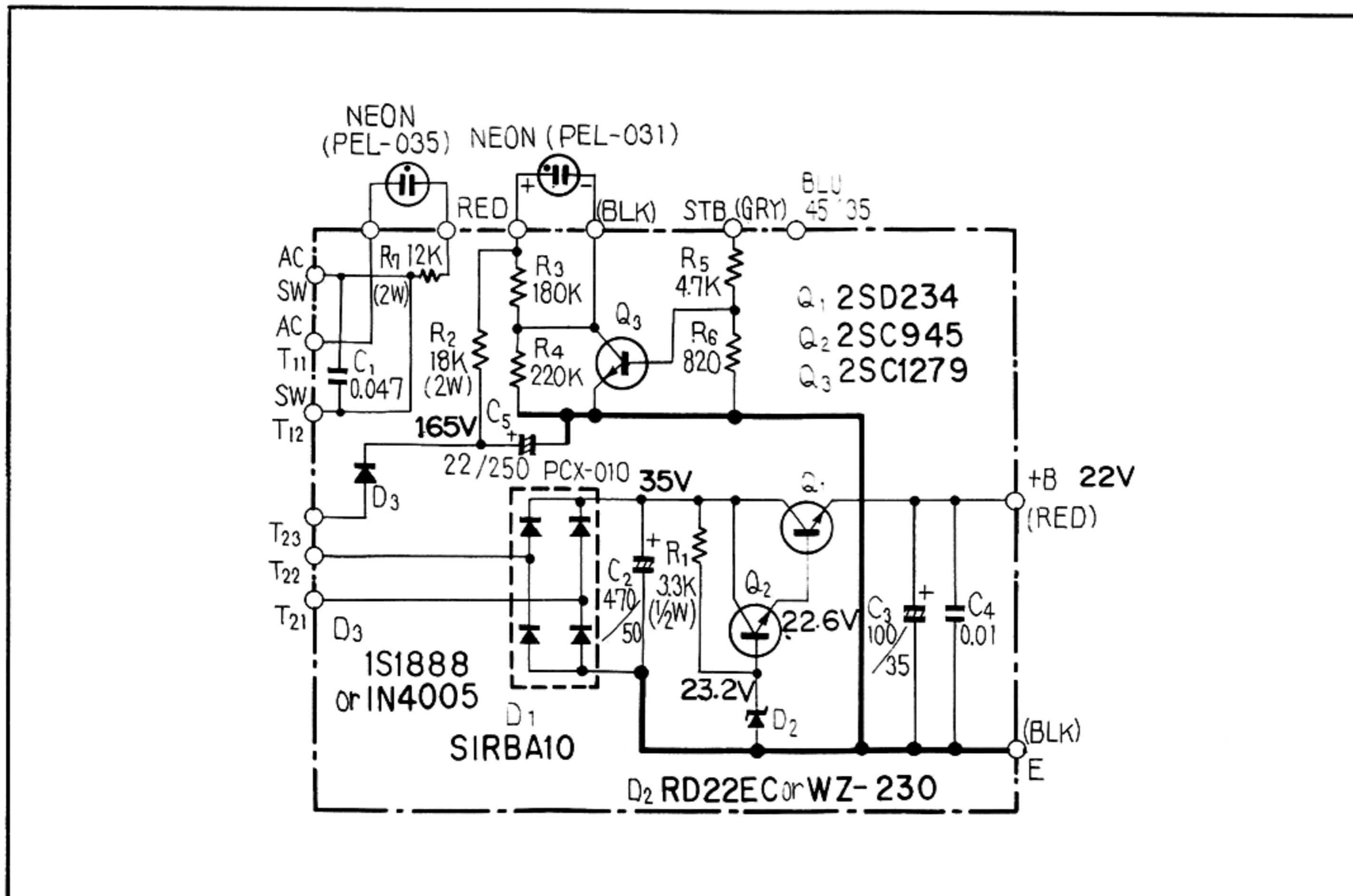

Parts List of Power Supply Assembly
 PWR-040 (KUT)
 PWR-042 (KCT)

CAPACITORS

Part No.	Symbol & Description
PCL-019	C1 (KCT)
KCE-005	C1 (KUT)
CEA 471P 50	C2
CEA 101P 35	C3
CKDYF 103Z 50	C4
CEA 220P 250	C5

Note: When ordering resistors, convert the resistance value into code form, and then rewrite the part no. as before.

RESISTORS

Part No.	Symbol & Description
RD½PS □□□J	R1
RS2P □□□J	R2
RD¼PS □□□J	R3-R6
RS2P □□□J	R7

SEMICONDUCTORS AND OTHER

Part No.	Symbol & Description
2SD234-0	Q1
2SC945-P or K	Q2
2SC1279S	Q3
SIRBA10	D1
RD22EC (WZ-230)	D2
1S1888 (1N4005)	D3

RESISTANCE VALUE CODES

Code numbers of resistors used in Pioneer equipment are expressed in the following way:—

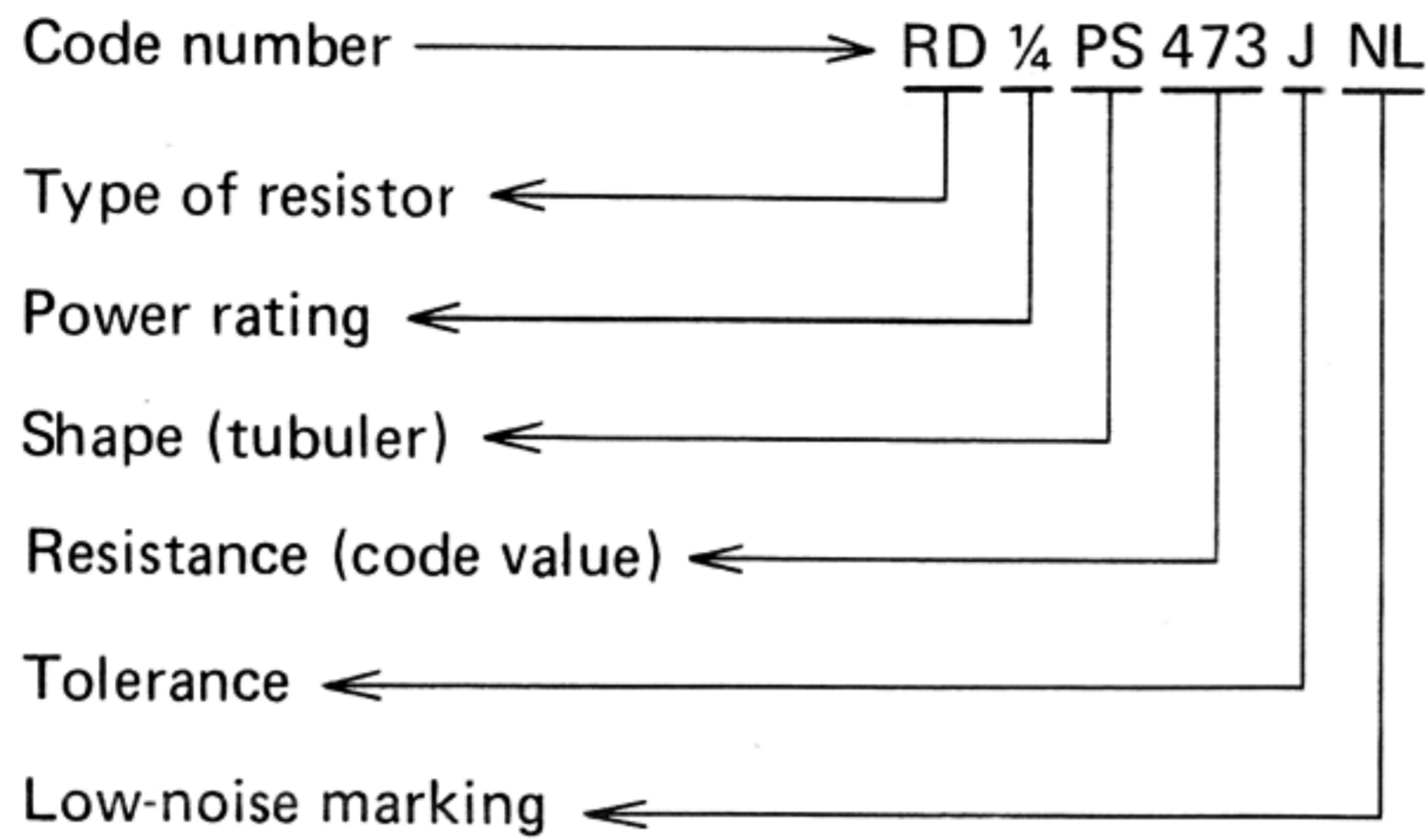

Furthermore, in the list of parts found in the Service Manual, the resistance (code value) part of the above code number is expressed as □□□ or □□□□.

Resistors included in the Service Manual list of parts

Ex. RD 1/4 PS □□□ JNL

When ordering resistor components, first ascertain the actual resistance value from the circuit diagram, and then convert it into code no. form as shown in the following examples.

For further details on code numbers, refer to "Tuning Fork" VOL. 1.

Ex. 1 For □□□□ Codes

* General resistors

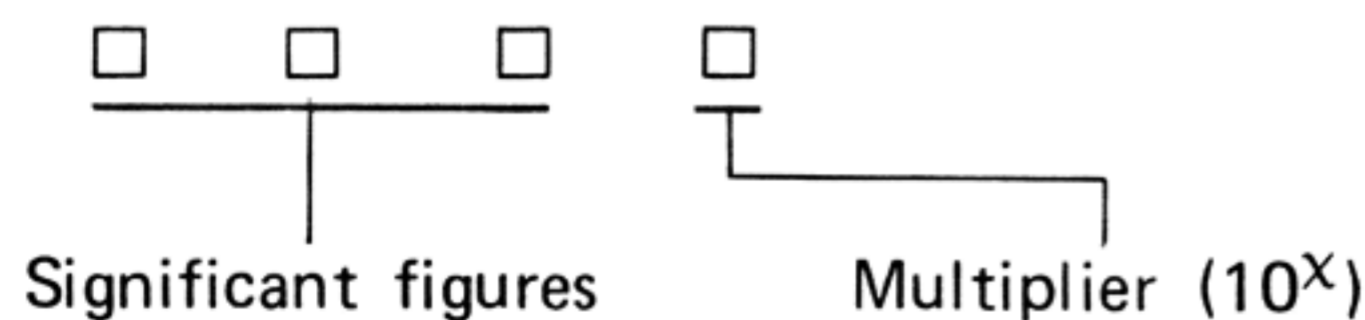

* Resistors with fractional values

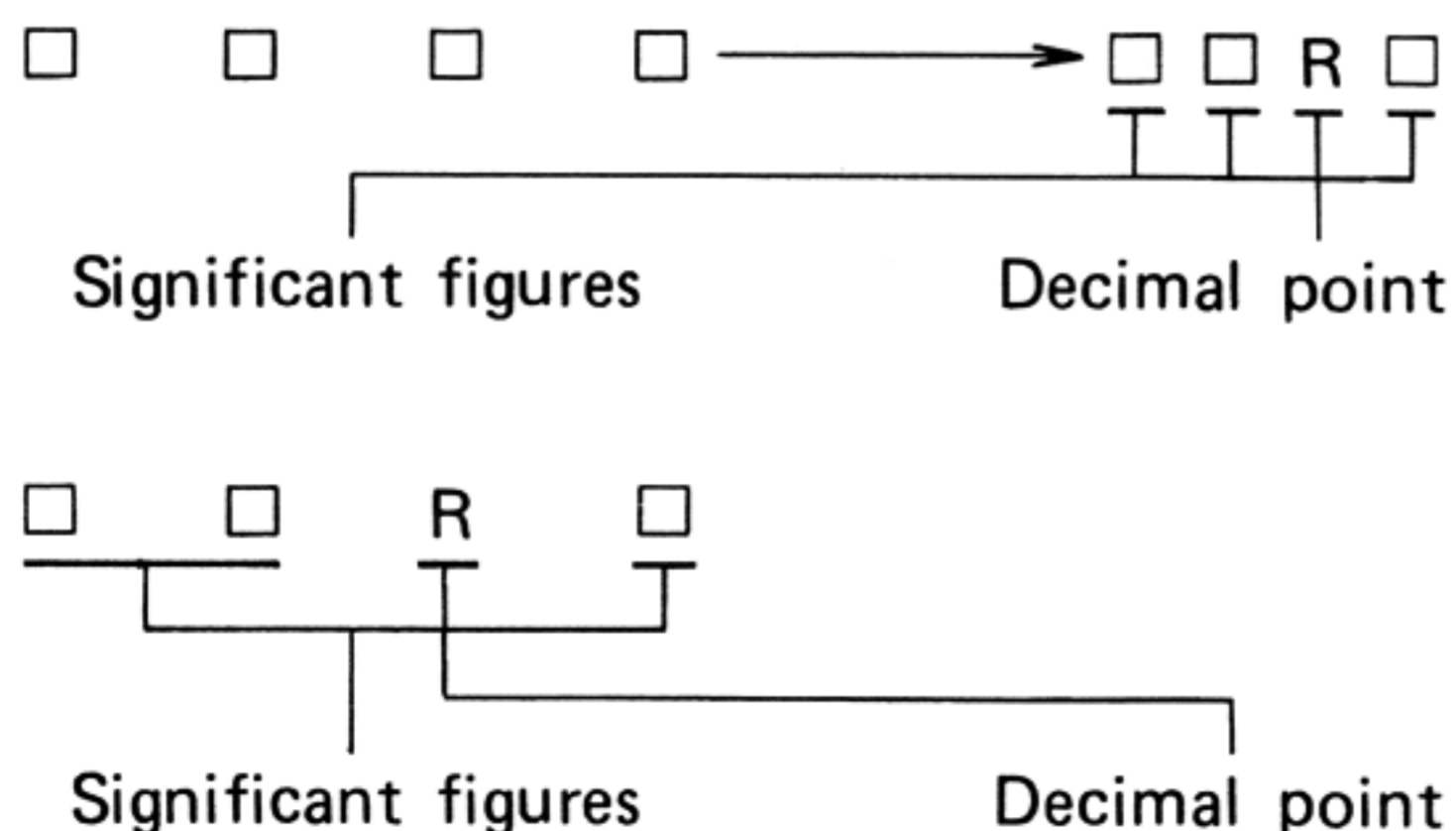

Ex. 1

Nominal resistance (Ω)	Significant figure (three figures)	Multiplier (10 ^X)	Resistance value code
5.1	510	5R10
5.62	562	5R62
10	100	10R0
22.5	225	22R5
110	110	x10 ⁰	1100
1k (1000)	100	x10 ¹	1001
1.56k (1560)	156	x10 ¹	1561
10k (10000)	100	x10 ²	1002
33.6k (33600)	336	x10 ²	3362
112k (112000)	112	x10 ³	1123
1M (1000000)	100	x10 ⁴	1004
1.56M (1560000)	156	x10 ⁴	1564

Ex. 2 For □□□ Codes

* General resistors

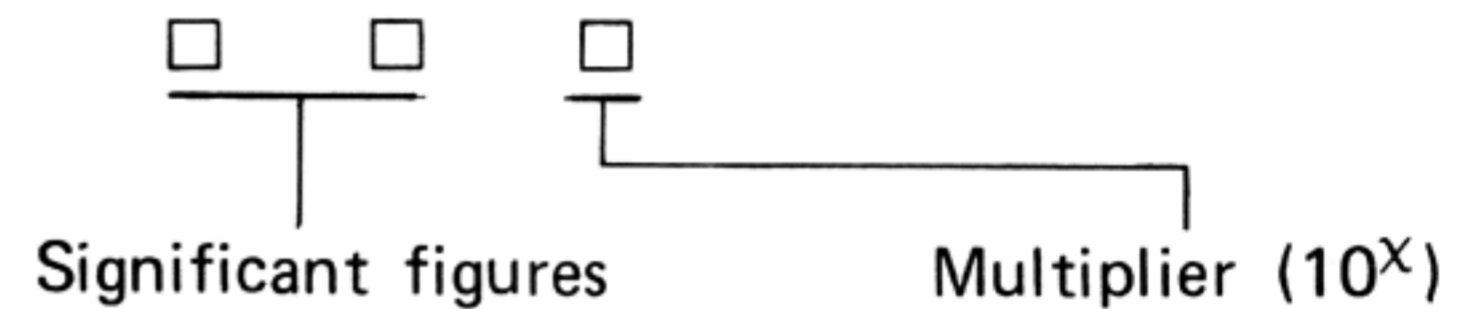

* Resistors with fractional values

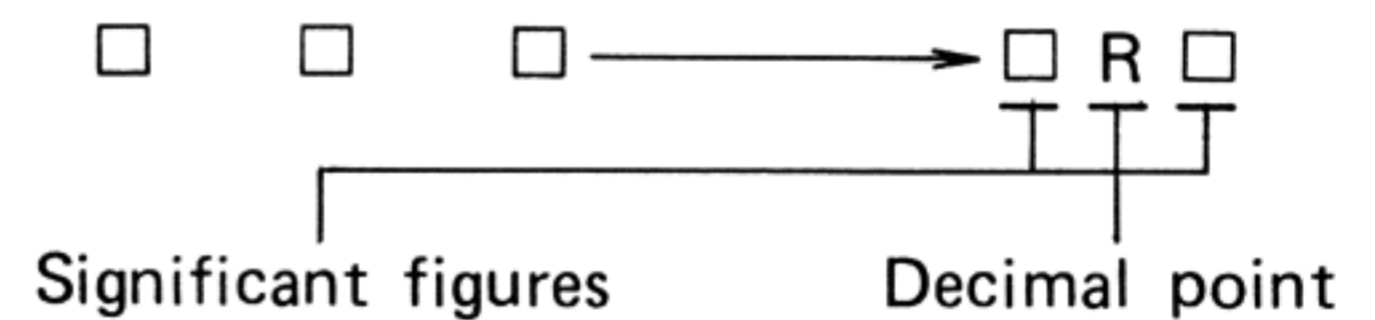

Ex. 2

Nominal resistance (Ω)	Significant figure (two figures)	Multiplier (10 ^X)	Resistance value code
0.5	05	0R5
1.5	15	1R5
1	01	x10 ⁰	010
22	22	x10 ⁰	220
330	33	x10 ¹	331
1k (1000)	10	x10 ²	102
5.6k (5600)	56	x10 ³	562
68k (68000)	68	x10 ³	683
820k (820000)	82	x10 ⁴	824
1M (1000000)	10	x10 ⁵	105
2.2M (2200000)	22	x10 ⁵	225

PIONEER ELECTRONIC CORPORATION 4-1, Meguro 1-Chome, Meguro-ku, Tokyo 153, Japan
U.S. PIONEER ELECTRONICS CORPORATION 85 Oxford Drive, Moonachie, New Jersey 07074, U.S.A.
PIONEER ELECTRONIC (EUROPE) N.V. Luithagen-Haven 9, 2030 Antwerp, Belgium
PIONEER ELECTRONICS AUSTRALIA PTY. LTD. 178-184 Boundary Road, Braeside, Victoria 3195, Australia