



Service Manual

Quartz PLL DIRECT DRIVE
FULL AUTOMATIC TURNTABLE

PL-630

 **PIONEER**[®]

MODEL PL-630 COMES IN FIVE VERSIONS DISTINGUISHED AS FOLLOWS:

Type	Voltage	Remarks
KCT	120V only	Canada model (Without cartridge)
KUT	120V only	U.S.A. model (Without cartridge)
HGT	220V – 240V	Europe or Oceania model (Without cartridge)
ST	110V – 120V, 220V – 240V (Switchable)	General export model (Without cartridge)
S/G	110V – 120V, 220V – 240V (Switchable)	U.S. Military model (Within cartridge)

- This service manual is applicable to the PL-630/KCT, KUT. For servicing of the other types please refer to the additional service manuals.

CONTENTS

1. SPECIFICATIONS	3	7. DESCRIPTION OF OPERATION	
2. PANEL FACILITIES	4	7.1 Mechanical Section	29
3. DISASSEMBLY	6	7.2 Control Section (Electrical Section)	31
4. PART LOCATION	8	7.3 Actual Operation (17cm record)	34
5. SCHEMATIC DIAGRAMS, P.C. BOARD PATTERNS AND PARTS LIST		7.4 Actual Operation of Mechanical Section . . .	35
5.1 Schematic Diagram	9	8. ADJUSTMENT	36
5.2 Control (A) Assembly (PWX-035)	11	9. D.D. MOTOR CIRCUIT DESCRIPTIONS AND TROUBLE SHOOTING	
5.3 P.C. Board Connection Diagram	12	9.1 Block Diagram	39
5.4 Control (B) Assembly (XWX-007)	15	9.2 Motor Operation	41
5.5 Switch Assembly (XWX-008) and Lamp Assembly (XWX-009)	15	9.3 Operation of The PD1003 IC (Oscillator Stage)	43
5.6 Tonearm Drive Assembly (PWX-027)	16	9.4 Operation of The PA2004 IC (Comparator Control)	43
5.7 Power Supply Assembly	17	9.5 Operation of The PA2005 IC (Drive Control)	43
5.8 Oscillator Assembly (PWX-022)	17	9.6 Trouble Shooting Chart	48
5.9 Drive Control Assembly (PWG-017)	18		
EXPLODED VIEW			
6.1 Outer Parts	19		
6.2 Cabinet	21		
6.3 Tonearm (Arm Base)	23		
6.4 Under Base	25		
6.5 D. D. Motor (PXM-067)	26		
6.6 Packing	27		

1. SPECIFICATIONS

Motor and Turntable

Drive System	Direct-drive
Motor	Quartz PLL Hall motor
Turntable Platter	330mm diam. aluminum alloy die-cast
Inertial Mass	340kg-cm ² (including platter mat mass)
Speeds	33-1/3 and 45rpm
Speed Control Range	±6%
Wow and Flutter	Less than 0.025% (WRMS)
Signal-to-Noise Ratio	More than 75dB (DIN-B) (with Pioneer cartridge model PC-600)

Rotational Characteristics

Build-up Time	Within 90° rotation at 33-1/3 rpm
Speed Deviation	Less than 0.002%
Speed vs. Load Characteristics	Stable up to 200 grams drag load
Speed Drift	Less than 0.00008%/h at 33-1/3 rpm Less than 0.00003%/degree temp. change at 33-1/3 rpm

Tonearm

Type	Static-balance type, S-shaped pipe arm
Effective Arm Length	237mm
Overhang	15mm
Usable Cartridge Weight	4g (min.) to 12.5g (max.) (For cartridge weights over 8.5 grams, attach the sub weight)
Arm Height Adjust Range	±3mm

Subfunctions

- Auto lead-in
- Auto-return
- Auto cut
- Quick repeat
- Quick play
- Quick stop
- Anti-skating force control
- Stylus pressure direct-readout counterweight
- Arm height adjusting device
- Cueing device
- Pitch meter
- Free stop hinges

NOTE:

Specifications and design subject to possible modification without notice, due to improvements.

Semiconductors

ICs	7
Transistors	17
Diodes	9
Hall Elements	3
LED	10
Photo Transistors	2
CdS	1

Miscellaneous

Power Requirements	AC 120V 60Hz
Power Consumption	22W
Dimensions	470(W) x 148(H) x 418(D)mm 18-1/2(W) x 5-13/16(H) x 16-7/16(D) in.
Weight	12kg/26lb 7oz

Accessories

EP adaptor	1
Overhang gauge	1
Screwdriver	1
Sub weight	1
Cartridge mounting screws	6
Cartridge mounting nuts	2
Cartridge mounting washers	2
Operating instructions	1

2. PANEL FACILITIES

POWER SWITCH

ON Press this switch and the power will come on. The **ARM ELEVATION** switch indicator (▼) and **SPEED** switch indicator (45 or 33) will both light up.

OFF The power will be cut off when this switch is released, and the indicators will go off.

NOTES:

- The platter will not rotate when the tonearm is on the arm-rest even when the **POWER** switch is set to **ON**.
- Always set the **POWER** switch to **OFF** when you do not intend to use your turntable.

AUTO SWITCH

ON Select this position for auto play (refer to page 10). When this switch is pushed, the **DISC SIZE** indicator (12"30) lights up.

OFF When this switch is released, the auto mechanism is disengaged, and all the operations can be performed by hand. Set the switch to this position when playing a record whose size is not standardized since the tonearm will otherwise return to the arm rest automatically. When this switch is set to **OFF**, you will not be able to perform auto play and repeat play operations. For record play, move the tonearm manually.

NOTE:

- When the **AUTO** switch is set to **OFF**, the **DISC SIZE** and **REPEAT** switch indicators will not light up even if the respective switches are pushed.

DISC SIZE SWITCHES

Press the switch that corresponds to the size of the record you want to hear for auto play operations. The corresponding switch indicator will then light up.

- 12"30 For 30cm records
- 10"25 For 25cm records
- 7"17 For 17cm records

NOTES:

- The 12"30 switch is selected automatically when the **POWER** switch is set to **ON**.
- These switches will not work if depressed when the tonearm is moving (auto return).

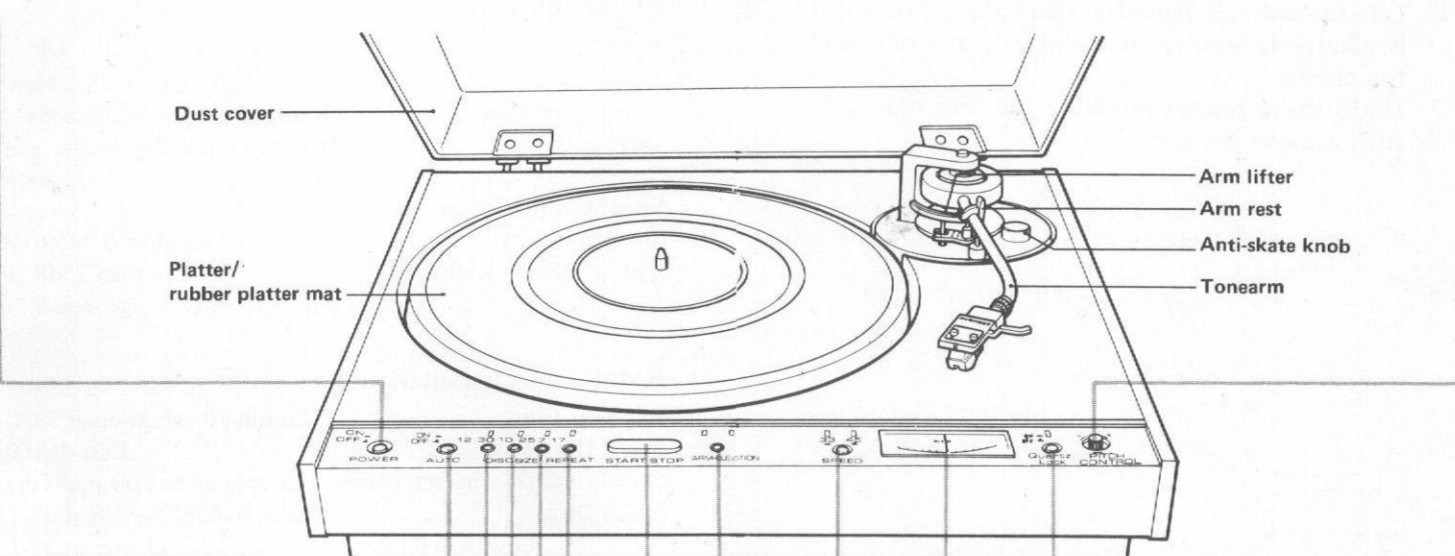

PITCH CONTROL KNOB

If this knob is rotated with the **QUARTZ LOCK** switch OFF, you will be able to increase or decrease the speed of the platter in respect to its rating. When the knob is rotated in the "+" direction, the platter will rotate faster, and when rotated in the "-" direction, it will rotate slower than its rating. The **PITCH** meter can be observed to check the amount of speed increase or decrease (up to 6% in either case).

REPEAT SWITCH

Press this switch for repeat play. When pressed, the indicator will light up, and the record will be played again (refer to page 11 for further details on repeat play). Press this switch again to release it. The indicator will go off and the repeat play function will be released.

NOTES:

- This switch cannot be operated even if depressed while the tonearm is moving out of contact with the record.
- There will be no repeat play when the **AUTO** switch is set to **OFF**.

START/STOP SWITCH

Press this switch for auto play. The platter will start to rotate, the tonearm will automatically move over to the edge of the record and play will begin (auto lead-in). If this switch is pressed during play, the tonearm will automatically return to the arm rest, the platter will stop rotating and play will be suspended (auto cut).

NOTES:

- This switch's **STOP** function has no effect on tonearm movement unless the tonearm is in contact with the record.
- This switch cannot be selected when the **AUTO** switch is set to **OFF**.

SPEED SWITCH

33 Set the switch to this position when playing a 33-1/3rpm record such as an LP. When it is depressed, the 33 indicator lights up, and the platter rotates at a speed of 33-1/3rpm.

45 Set the switch to this position when playing a 45rpm record like an EP. When it is depressed, the 45 indicator lights up, and the platter rotates at a speed of 45rpm.

ARM ELEVATION SWITCH

Use this switch to interrupt play temporarily or to perform manual play.

When the **DOWN** (▼) indicator lights up, the tonearm will descend and when the **UP** (▲) indicator lights up, the tonearm will rise. These two operations will be performed alternately every time the switch is pressed.

NOTES:

- When the **POWER** switch is set to **ON**, the tonearm will descend and the **DOWN** indicator lights up.
- Always set the switch to **DOWN** for auto play.
- When the switch is at **UP**, the auto return cancelling mechanism is actuated and so there will be no auto return or auto cut.

QUARTZ LOCK SWITCH

ON When this switch is pressed, the Quartz PLL circuitry is actuated and the indicator will light up. The switch is usually kept at this position. The platter will be accurately locked to the rotational speed corresponding to the position of the **SPEED** switch.

OFF When this switch is released, the Quartz PLL circuitry is disengaged, the **PITCH** meter lights up and the indicator goes off. Set the switch to this position for instrumental and other performances in accordance with the record being played.

PITCH METER

When the **QUARTZ LOCK** switch is set to **OFF**, the **PITCH** meter lamp will light up, and the variation in the rotational speed of the platter in respect to its rating (33-1/3 or 45rpm) can be read out on the meter.

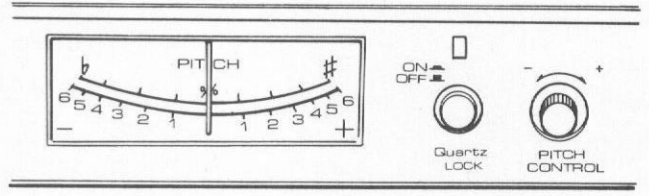

3. DISASSEMBLY

● Cabinet and Arm Base

1. Remove the 4 mounting screws retaining the upper cover.
2. Remove the AC mains connector.
3. Remove the output cord connector.
4. Remove the screws retaining the feet.
5. Move the arm to the vicinity of the center shaft.
6. Lift the cabinet from the rear side. As the cord is clamped, remove the cabinet while releasing the clamp.
7. Undo the 4 screws retaining the arm base, and then remove the arm base.

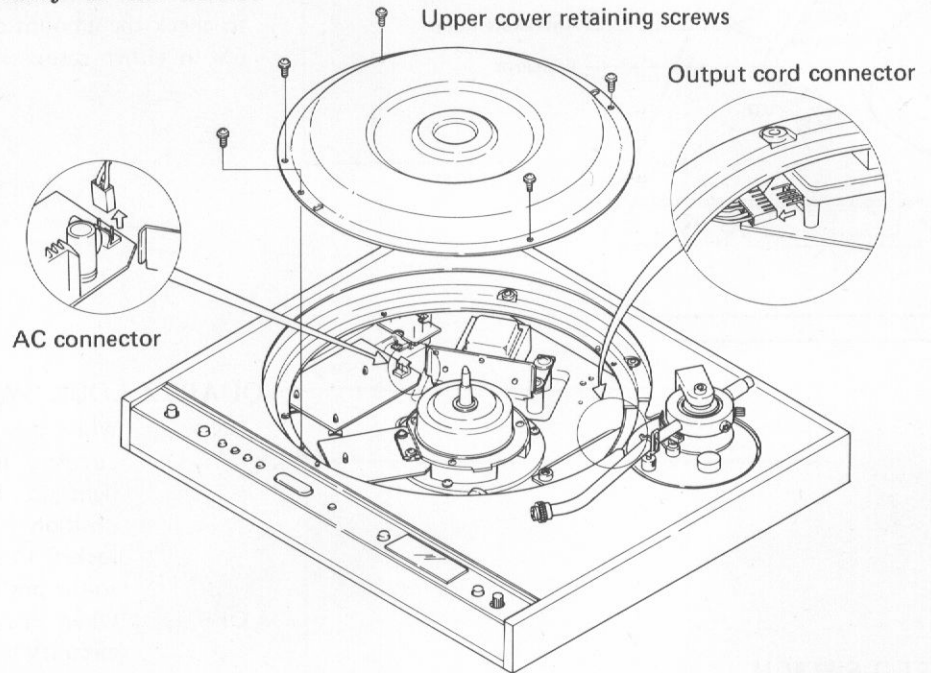

Fig. 1

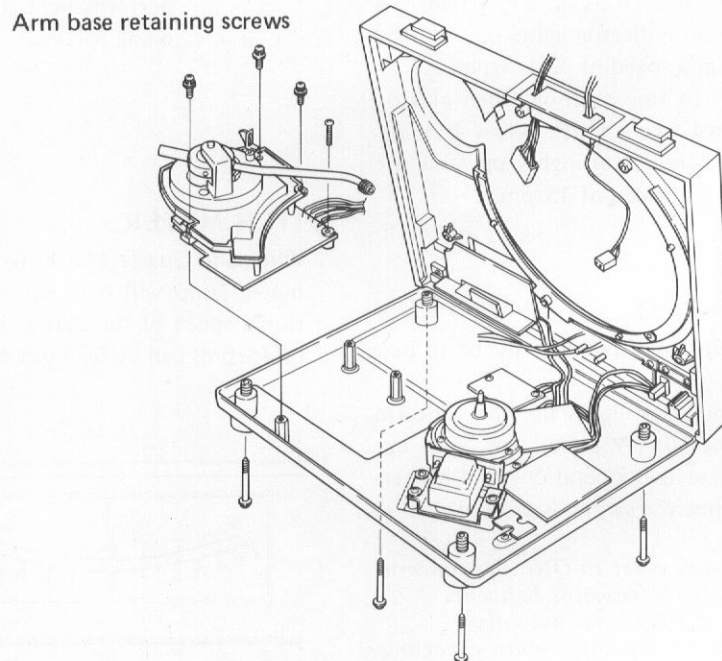

Fig. 2

- **Tonearm**

1. Loosen the mounting screws holding PU plates A and B which are fitted to the arm shaft, and remove the PU plates.
2. Undo the 2 screws retaining the tone arm, and then remove the tone arm.

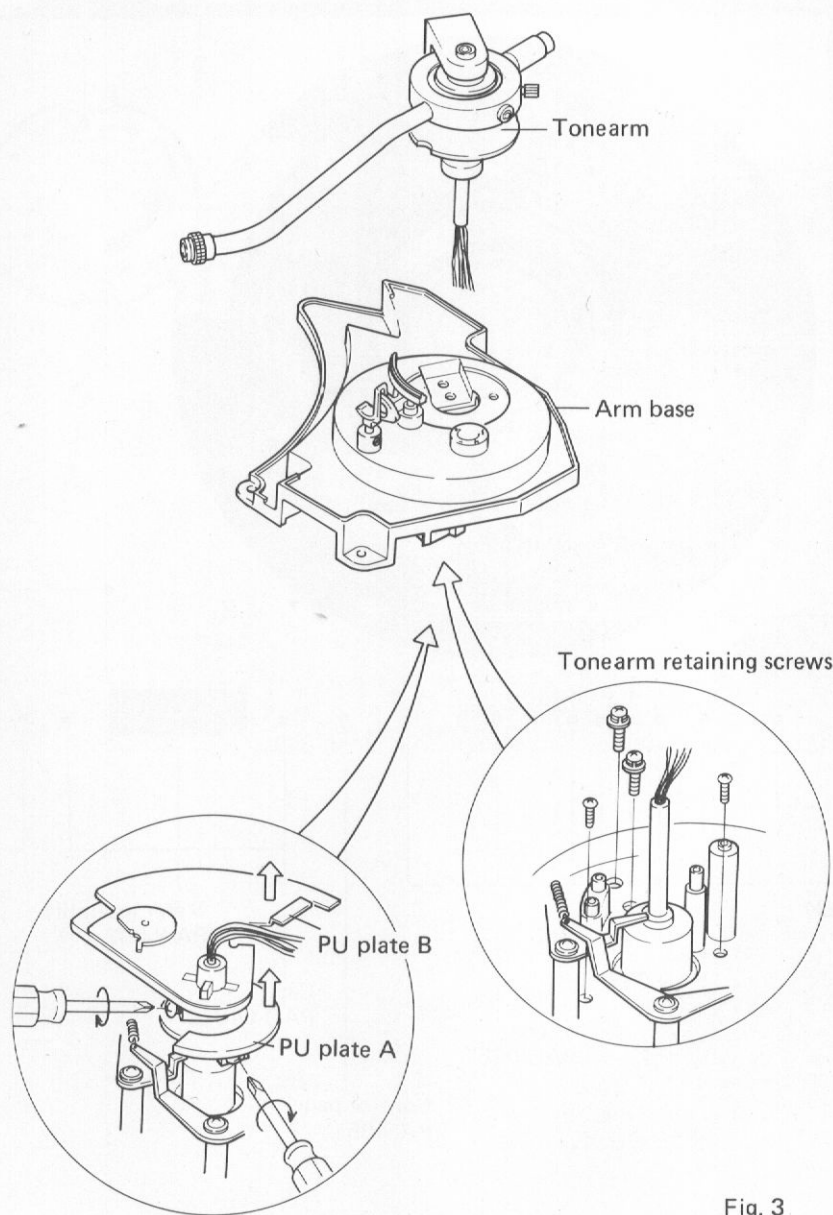
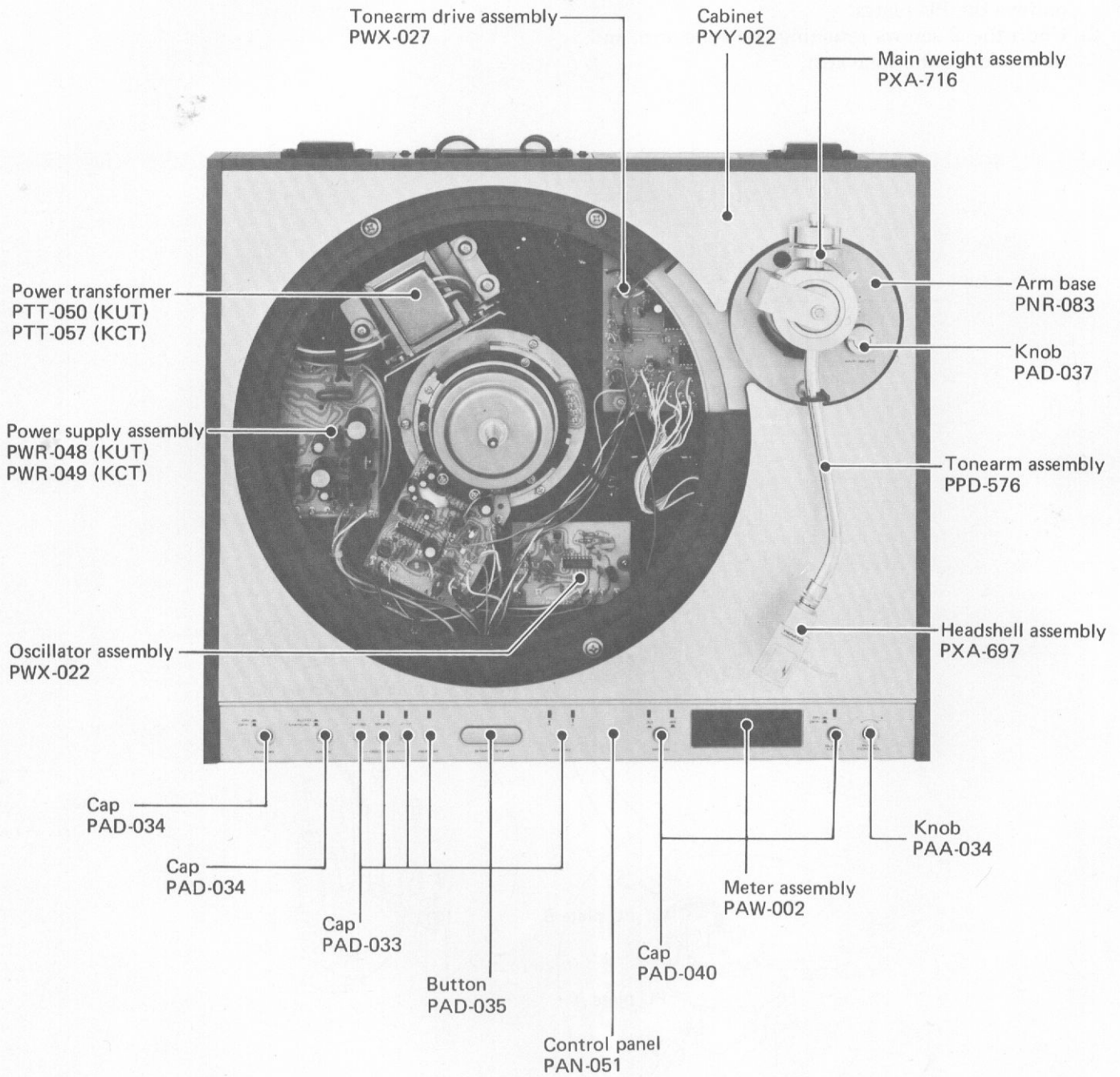

Fig. 3

4. PART LOCATION



5. SCHEMATIC DIAGRAMS P.C. BOARD PATTERNS AND PARTS LIST

5.1 SCHEMATIC DIAGRAM

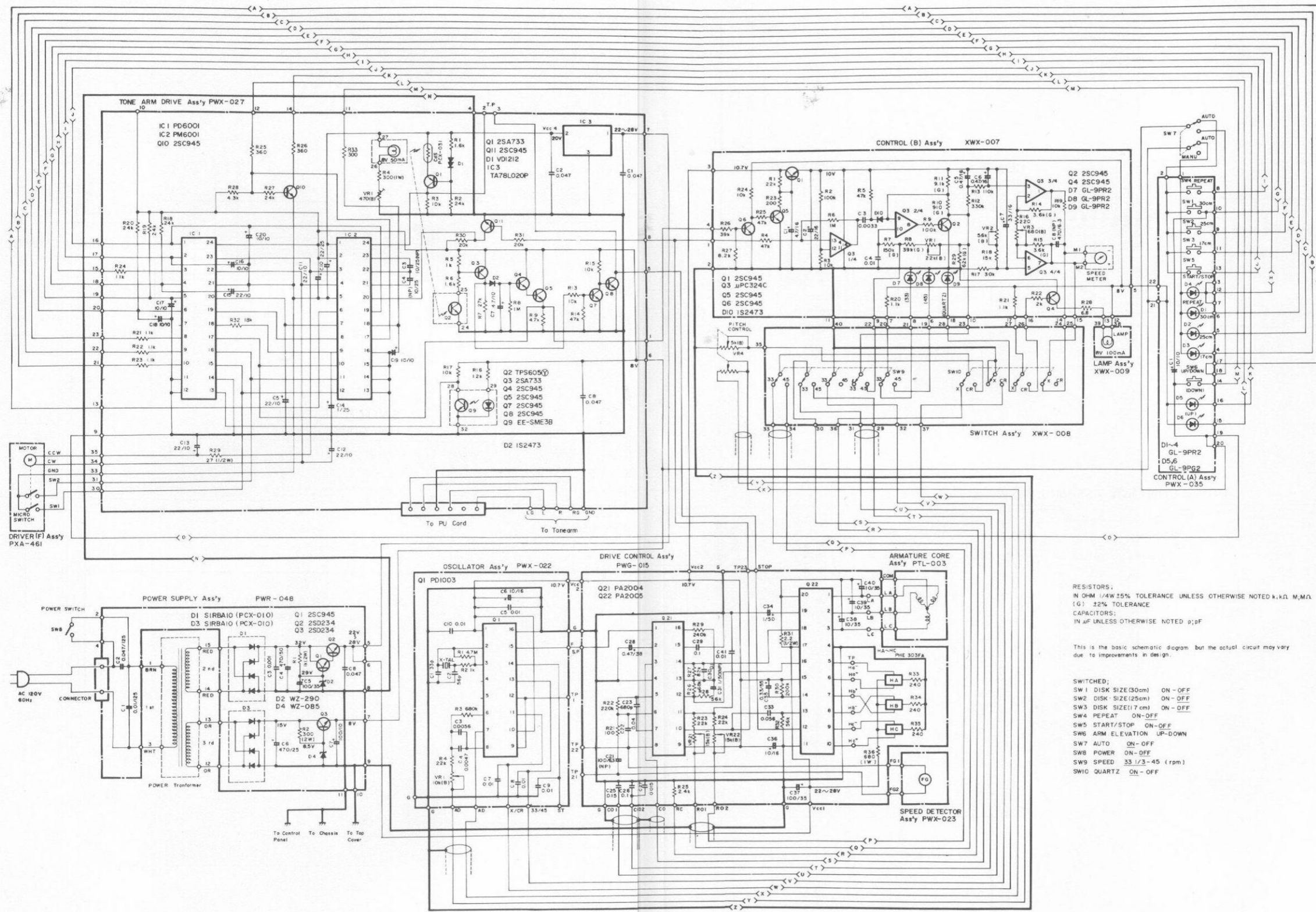

RESISTORS:
 IN OHM 1/4W 25% TOLERANCE UNLESS OTHERWISE NOTED k, KΩ, M, MΩ
 (G) 12% TOLERANCE
 CAPACITORS:
 IN μF UNLESS OTHERWISE NOTED p, pF

This is the basic schematic diagram but the actual circuit may vary due to improvements in design.

- SWITCHED:
- SW1 DISK SIZE (30cm) ON-OFF
 - SW2 DISK SIZE (25cm) ON-OFF
 - SW3 DISK SIZE (17cm) ON-OFF
 - SW4 REPEAT ON-OFF
 - SW5 START/STOP ON-OFF
 - SW6 ARM ELEVATION UP-DOWN
 - SW7 AUTO ON-OFF
 - SW8 POWER ON-OFF
 - SW9 SPEED 33 1/3-45 (rpm)
 - SW10 QUARTZ ON-OFF

NOTES:

- When ordering resistors, first convert resistance values into code form as shown in the following examples.

Ex. 1 When there are 2 effective digits (any digit apart from 0), such as 560 ohm and 47k ohm (tolerance is shown by J = 5%, and K = 10%).

560Ω 56 × 10¹ 561 RD¼PS 561J
 47kΩ 47 × 10³ 473 RD¼PS 473J
 0.5Ω 0R5 RN2H 0R5K
 1Ω 010 RSIP 010K

Ex. 2 When there are 3 effective digits (such as in high precision metal film resistors).

5.62kΩ 562 × 10¹ 5621 RN¼SR 5621F

Miscellaneous Part

Part No.	Description
PWX-027	Tonearm drive assembly
PWX-035	Control (A) assembly
XWX-007	Control (B) assembly
XWX-008	Switch assembly
XWX-009	Lamp assembly
PWG-017	Drive control assembly
PWX-022	Oscillator assembly
PTL-003	Armature core assembly
PWR-049	Power supply assembly (KCT)
PWR-048	Power supply assembly (KUT)
PTT-057	Power transformer (KCT)
PTT-050	Power transformer (KCU)
PSA-002	Power switch

5.2 CONTROL (A) ASSEMBLY (PWX-035)

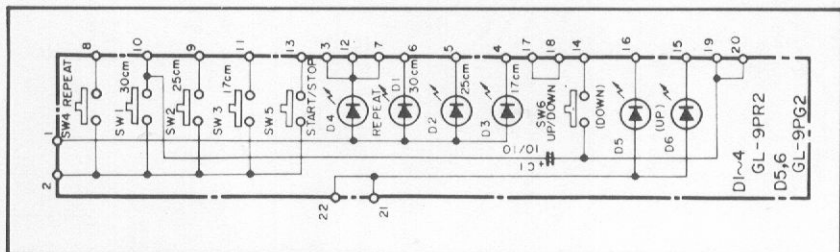

Parts List of Control (A) Assembly (PWX-035)

Part No.	Symbol & Description
PSG-009	SW1-SW6 Switch
CEA 100P 10	C1
GL-9PR2	D1-D4 (without assembly)
GL-9PG2	D5, D6 (without assembly)

External Appearances of Transistors

2SC945
2SA733

2SD234

PA2004
PD1003

PA2005

TPS605

PD6001
PM6001

TA78L020P

EE-SM3B

μPC324

5.3 P.C. BOARD CONNECTION DIAGRAM

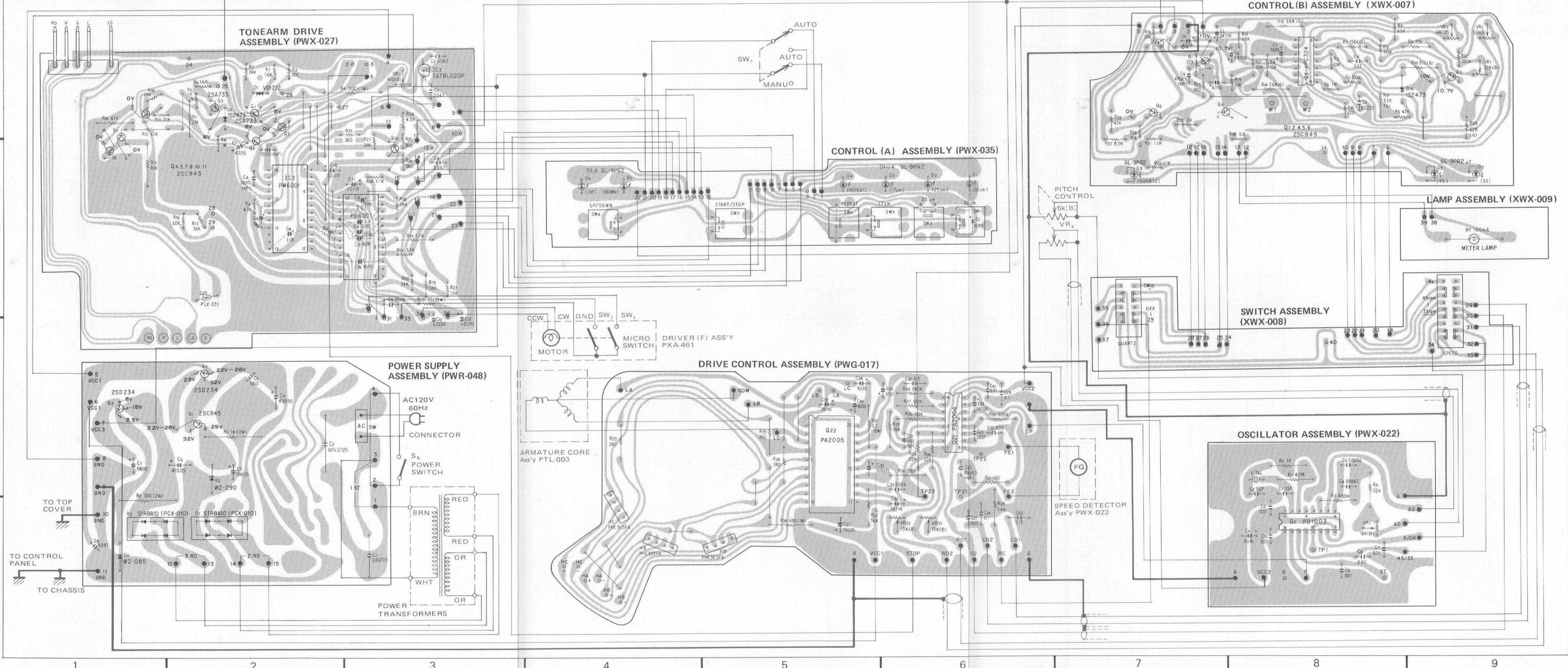

5.4 CONTROL (B) ASSEMBLY (XWX-007)

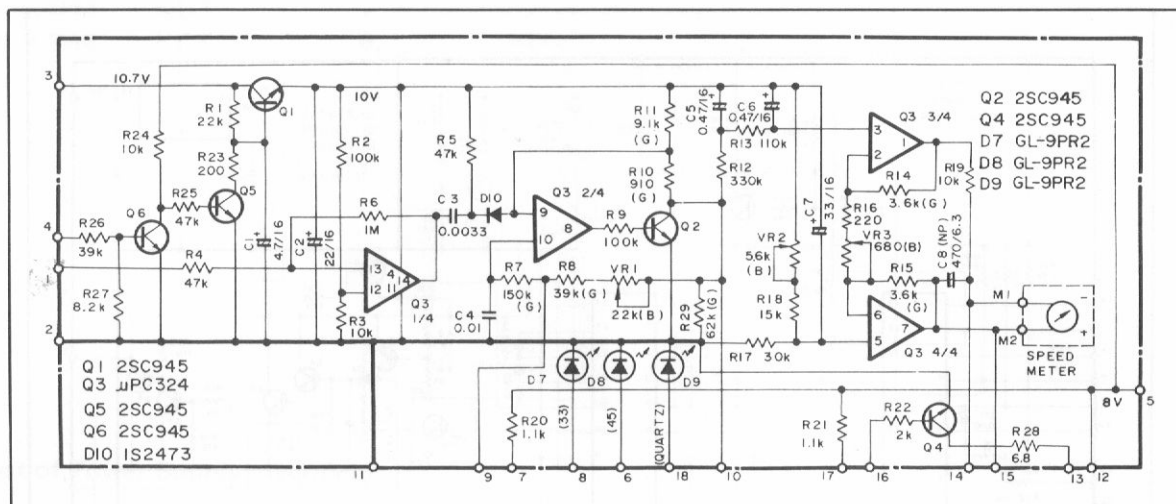

Parts List of Control (B) Assembly (XWX-007)

SEMICONDUCTORS

Part No.	Symbol & Description
2SC945-P	Q1, Q2
μPC-324C	Q3
2SC945-P or Q	Q4 - Q6
1S2473	D10
GL-9PR2	D7 - D9

CAPACITORS

Part No.	Symbol & Description
CEA 4R7P 16	C1
CEA 220P 16	C2
CQMA 332K 50	C3
CQMA 103J 50	C4
CSZA R47M 16	C5, C6
CSZA 330M 16	C7
CEA 471M 6.3NP	C8

RESISTORS

Part No.	Symbol & Description
RD¼VS □□□ J	R1-R6, R9, R12, R13, R16-R28
RN¼PS □□□ G	R7, R8
RD¼PS □□□ G	R10, R11, R14, R15
RD¼VS □□□ G	R29
PCP-020 or PCP-013	VR1
PCP-023 or PCP-024	VR2
PCP-022 or PCP-007	VR3

Note: When ordering resistors, convert the resistance value into code form, and then rewrite the part no. as before.

5.5 SWITCH ASSEMBLY (XWX-008) and LAMP ASSEMBLY (XWX-009)

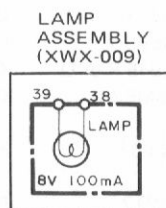
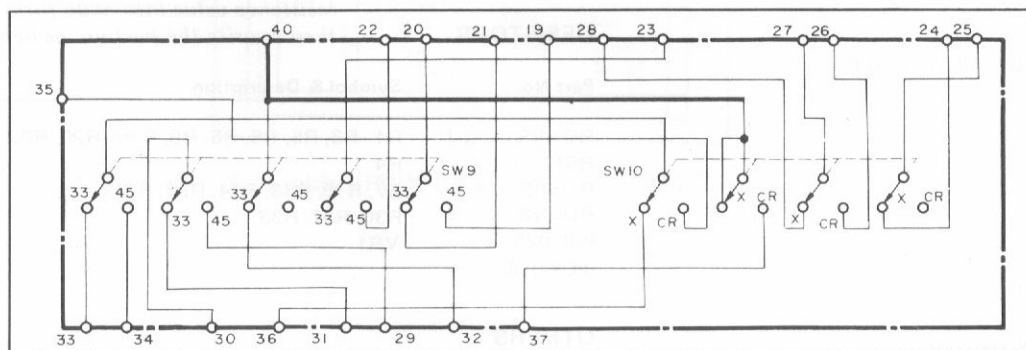

Parts List of Switch Assembly (XWX-008)

Part No.	Symbol & Description
PSG-010	Push switch
PSG-011	Push switch

Part List of Lamp Assembly (XWX-009)

Part No.	Symbol & Description
PEL-033	Lamp

5.6 TONEARM DRIVE ASSEMBLY (PWX-027)

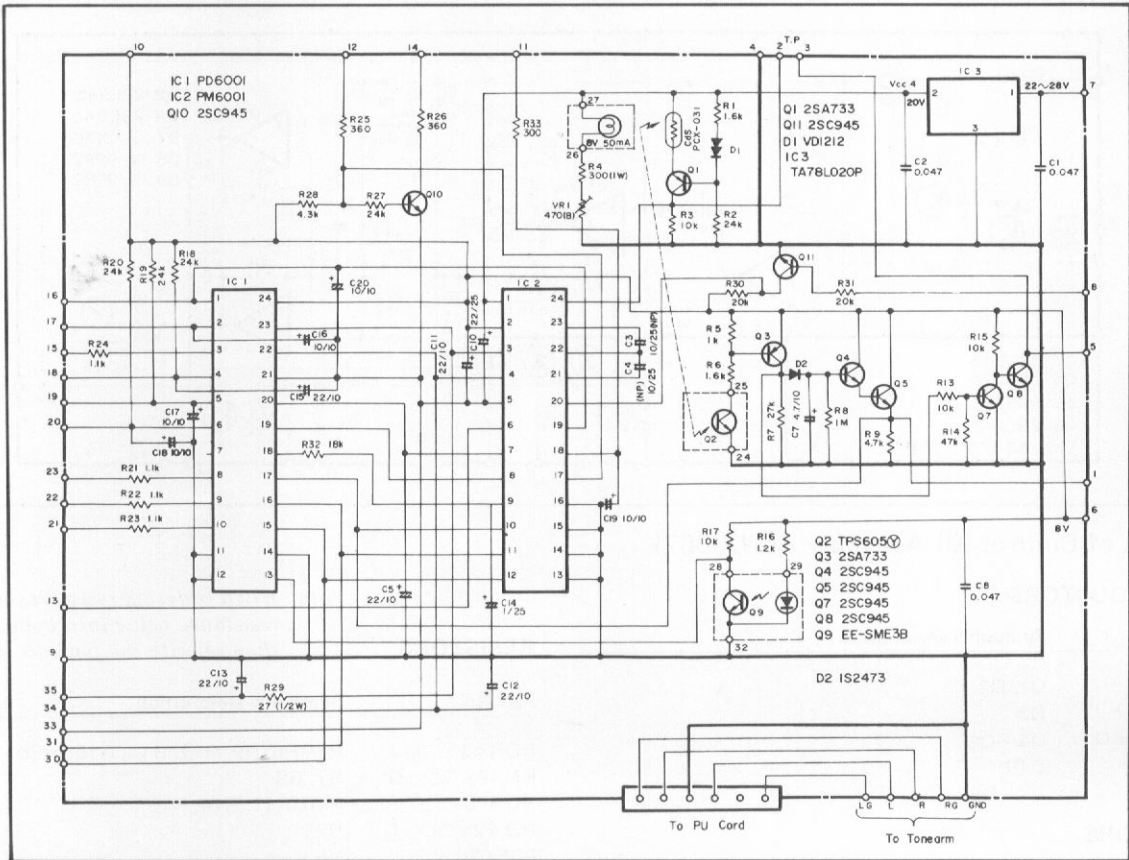

Parts List of Tonearm Drive Assembly (PWX-027)

SEMICONDUCTORS

Part No. Symbol & Description

PD6001	IC1
PM6001	IC2
TA78L020P	IC3
2SA733P or Q	Q1, Q3
TPS605-Y	Q2
2SC945-P or Q	Q4, Q5, Q7, Q8, Q10, Q11
EE-SME3B	Q9
PCX-031	cds
VD1212	D1
1S2473	D2

CAPACITORS

Part No. Symbol & Description

CKDYF 473Z 50	C1, C2, C8
CEA 100P 25NP	C3, C4
CEA 220P 10	C5, C12, C13, C11
CSZA 4R7M 10	C7
CEA 220P 25	C10
CSZA 010M 25	C14

Part No. Symbol & Description

CSZA 220M 10	C15
CSZA 100M 10	C16-C20

Note: When ordering resistors, convert the resistance value into code form, and then rewrite the part no. as before.

RESISTORS

Part No. Symbol & Description

RD $\frac{1}{2}$ VS $\square\square\square$ J	R1-R3, R5, R6, R8, R9, R16-R20, R22-R28
RS1P $\square\square\square$ J	R4
RD $\frac{1}{2}$ PS $\square\square\square$ J	R7, R15, R13, R14, R32, R21,
RD $\frac{1}{2}$ VS $\square\square\square$ J	R30, R31, R33
PCP-025	VR1
(PCP-010)	

OTHERS

Part No. Description

PEB-123	Rubber bush
PKP-020	Connector 5p
PEL-025	Lamp

5.7 POWER SUPPLY ASSEMBLY

PWR-048 ... KUT

PWR-049 ... KCT

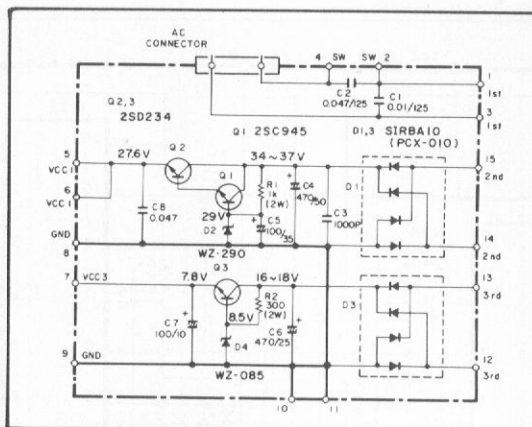

Parts List of Power Supply Assembly

Part No.	Symbol & Description	Part No.	Symbol & Description
2SC945-P or Q	Q1	PCL-019 (KCT)	C2
2SD234-O or Y	Q2, Q3	KCE-005 (KUT)	C2
SIRBA10	D1, D3	CKDYF 102Z 50	C3, C8 (KUT)
WZ-290	D2	CEA 471P 50	C4
WZ-085	D4	CEA 101P 35	C5
RS2P 102J	R1	CEA 471P 25	C6
RS2P 301J	R2	CEA 101P 10	C7
PCL-020 (KCT)	C1	CKDYF 473Z 50	C8 (KCT)
PCL-021 (KUT)	C1	PEC-043	Capacitor cover

5.8 OSCILLATOR ASSEMBLY (PWX-022)

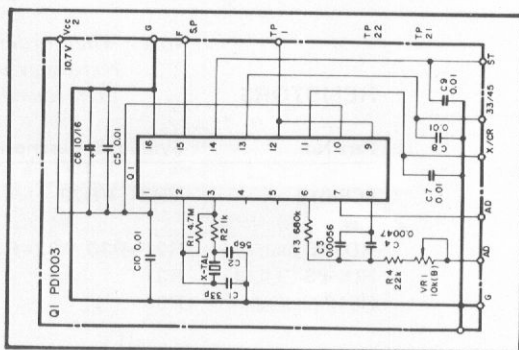

Note: When ordering resistors, convert the resistance value into code form, and then rewrite the part no. as before.

Parts List of Oscillator Assembly (PWX-022)

CAPACITORS

Part No.	Symbol & Description
CCDCH 330J 50	C1
CCDCH 560J 50	C2
CQMA 562J 50	C3
CQSH 472J 50	C4
CKDYF 103Z 50	C5, C7-C10
CEA 100P 16	C6

RESISTORS

Part No.	Symbol & Description
RD $\frac{1}{2}$ PS □□□ J	R1-R3
RN $\frac{1}{2}$ PS □□□ G	R4
PCP-015	VR1 10k Ω -B

SEMICONDUCTORS

Part No.	Description
PD1003	IC
PSS-003	Crystal

5.9 DRIVE CONTROL ASSEMBLY (PWG-017)

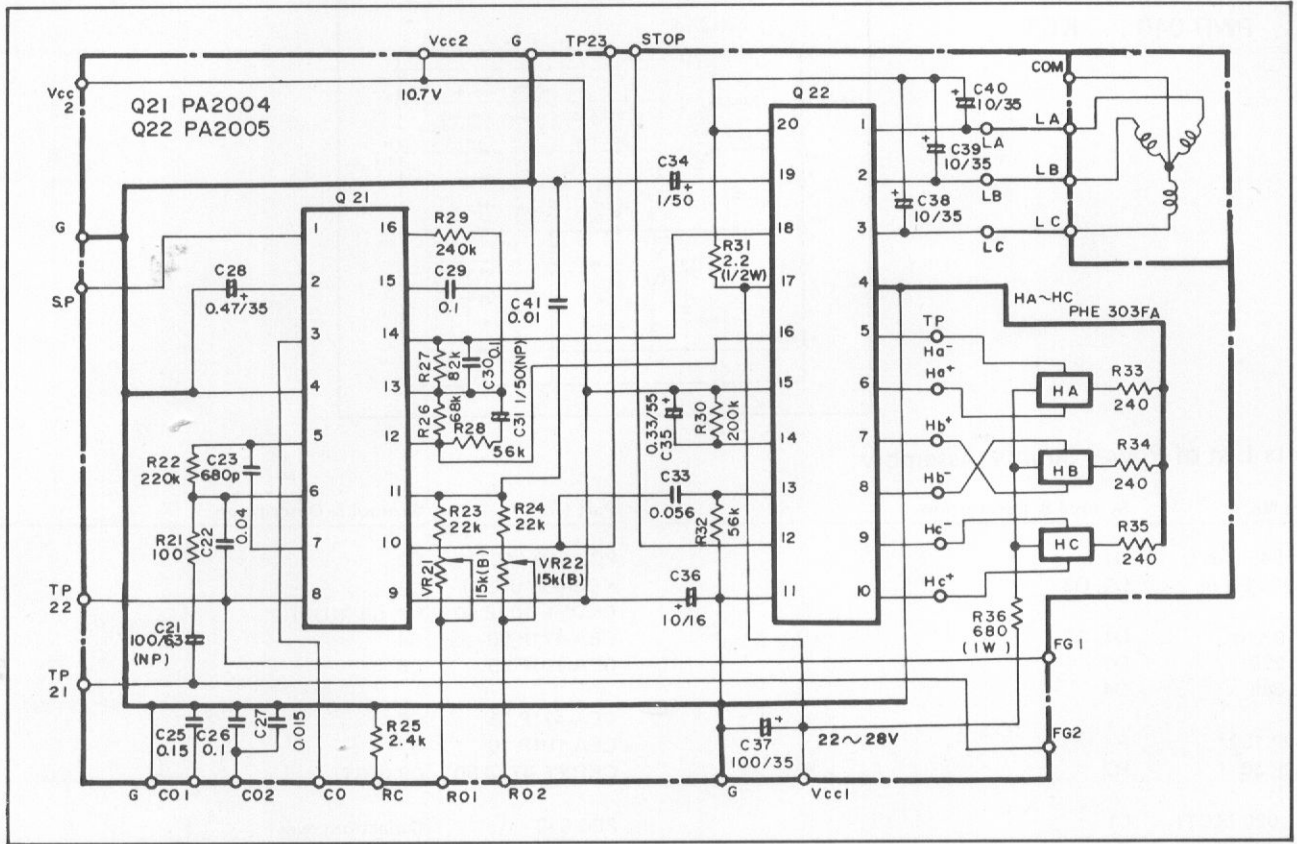

Parts List of Drive Control Assembly (PWG-017)

CAPACITORS

Part No.	Symbol & Description
CEA 101M 6.3NP	C21
CKDYF 403Z 50	C22
CKDYB 681K 50	C23
CQMA 154J 50	C25
CQMA 104J 50	C26, C30
CQMA 153J 50	C27
CSZA R47K 35	C28
CQMA 104K 50	C29
CEA 010M 50NP	C31
CQMA 563K 50	C33
CEA 010P 50	C34
CSZA R33K 35	C35
CSZA 100K 16	C36
CEA 101P 35	C37
CEA 100P 35	C38, C39, C40
CKDYF 103Z 50	C41

RESISTORS

Part No.	Symbol & Description
PCP-019	VR21, VR22 15kΩ-B
RD $\frac{1}{2}$ PS □□□ J	R21—R30, R32—R35
RD $\frac{1}{2}$ PS □□□ J	R31
RS1P □□□ J	R36

SEMICONDUCTORS

Part No.	Symbol & Description
PA2004	Q21
PA2005	Q22
PCX-039	HA, HB, HC Hall element
PTL-003	Armature core assembly

Note: When ordering resistors, convert the resistance value into code form, and then rewrite the part no. as before.

6. EXPLODED VIEW

NOTE: marked parts cannot be supplied.

6.1 OUTER PARTS

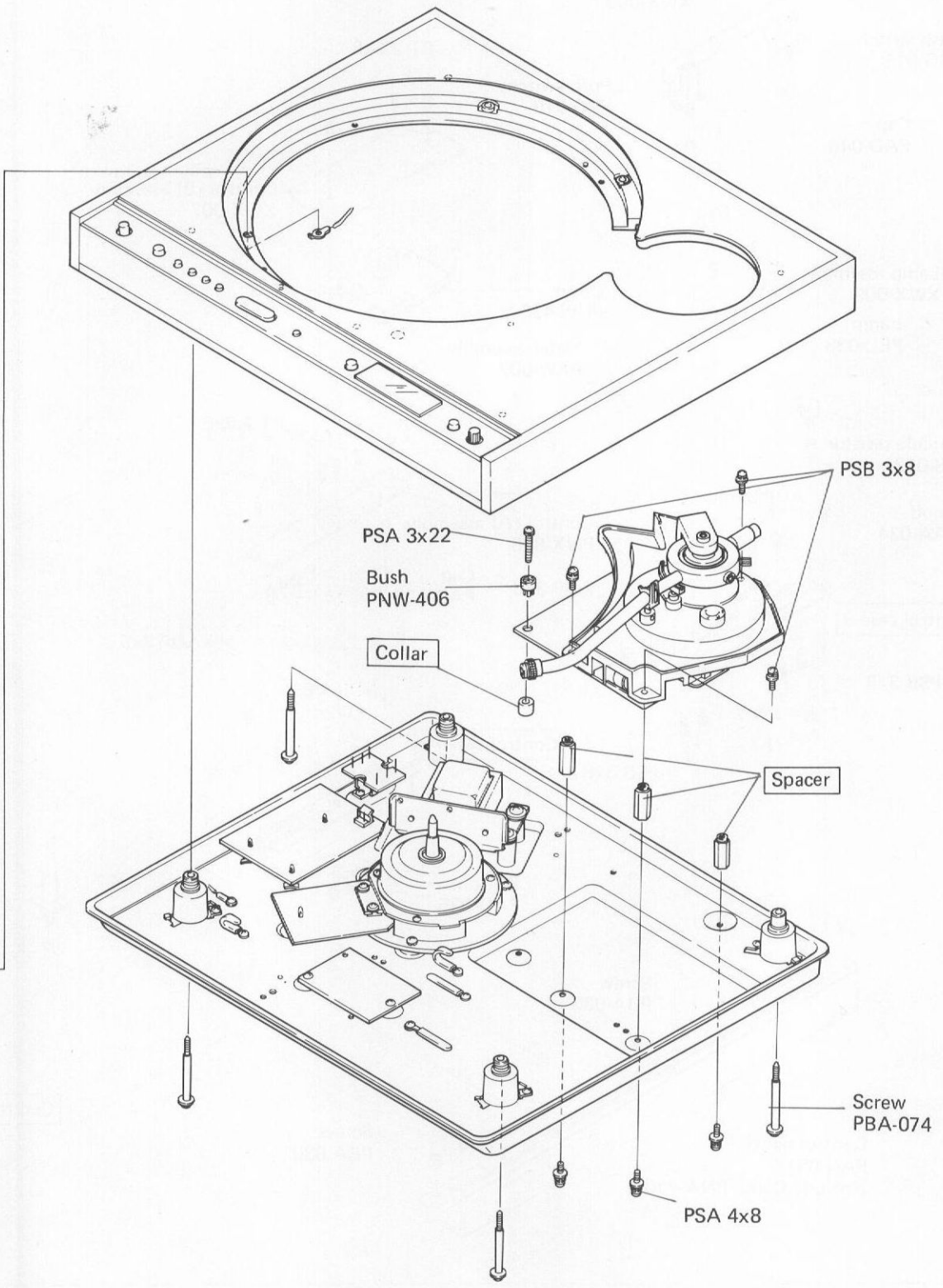
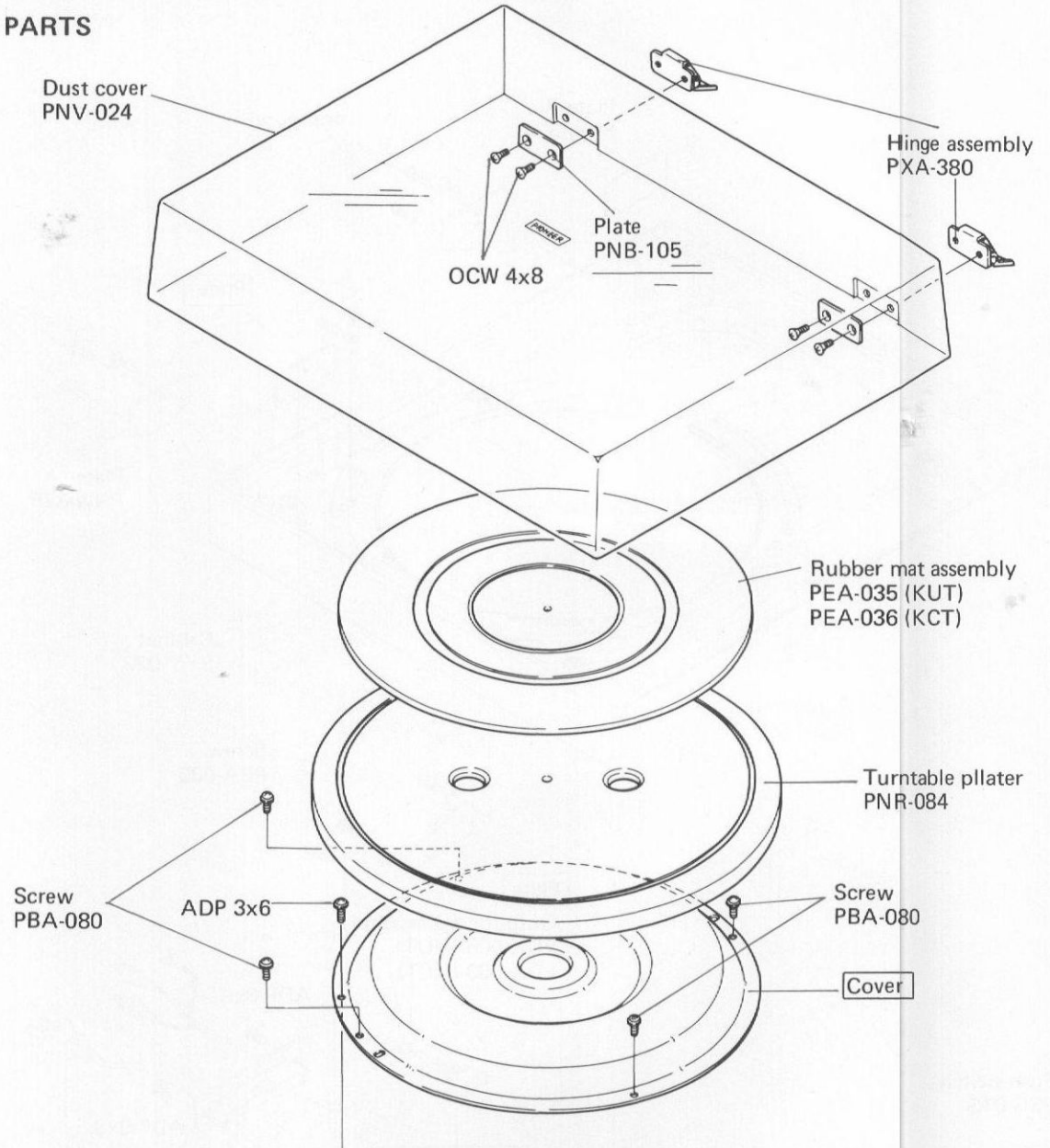

A
B
C
D

1 2 3 4 5 6

6.2 CABINET

NOTE:
 marked parts cannot be supplied.

A
B
C
D

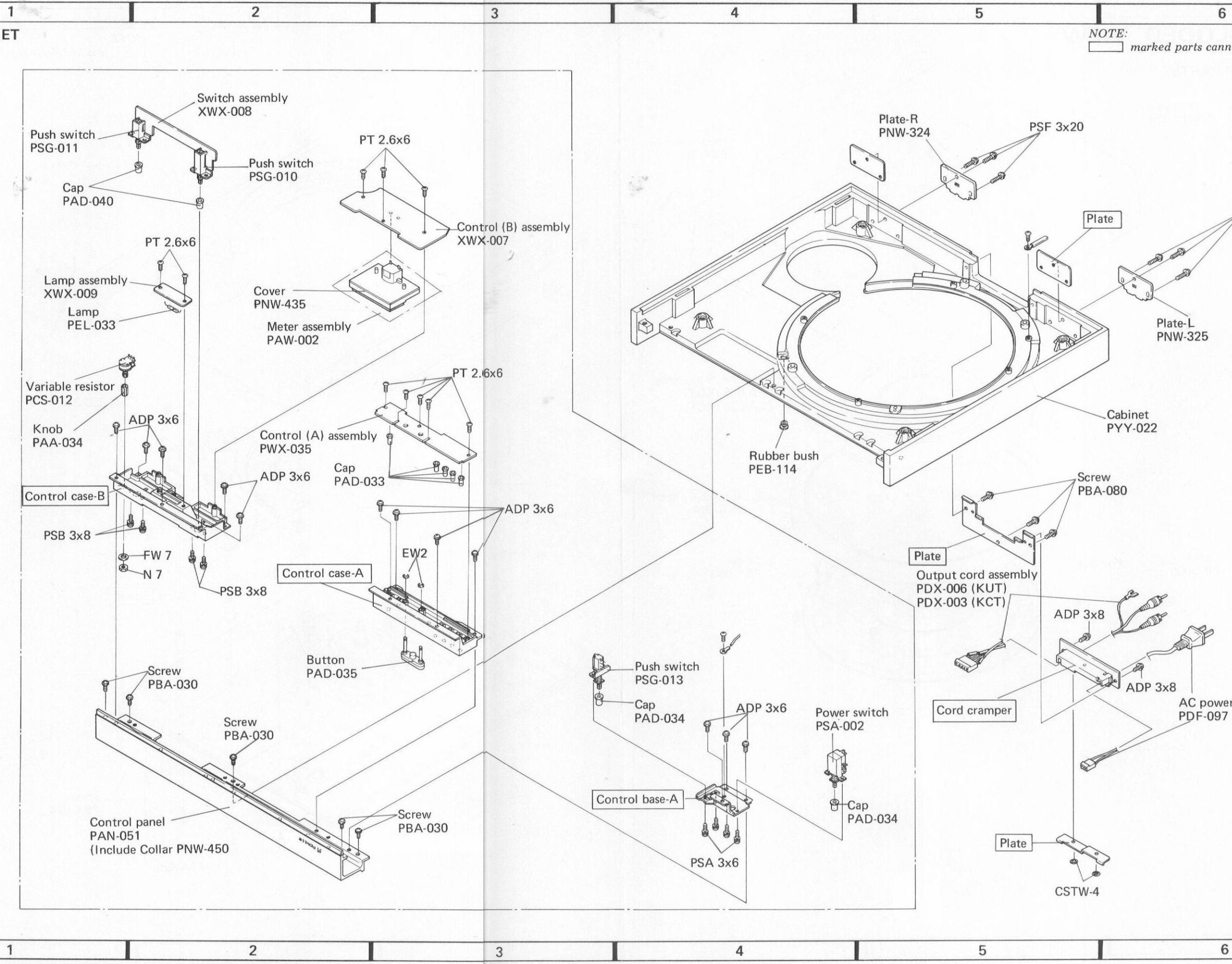

6.3 TONEARM (ARM BASE)

Mechanism assembly PXA-461

NOTE: marked parts cannot be supplied.

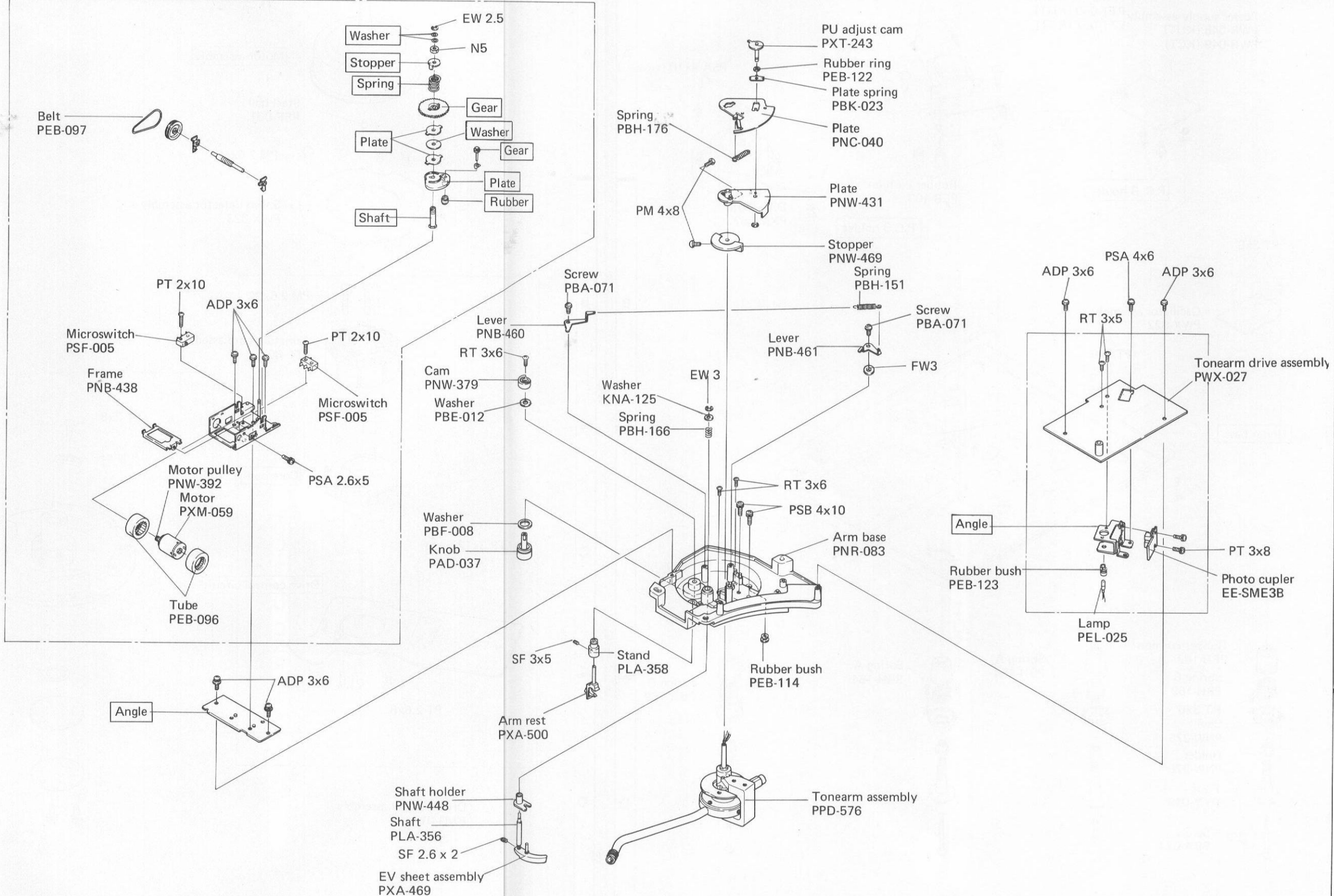

6.4 UNDER BASE

NOTE: marked parts cannot be supplied.

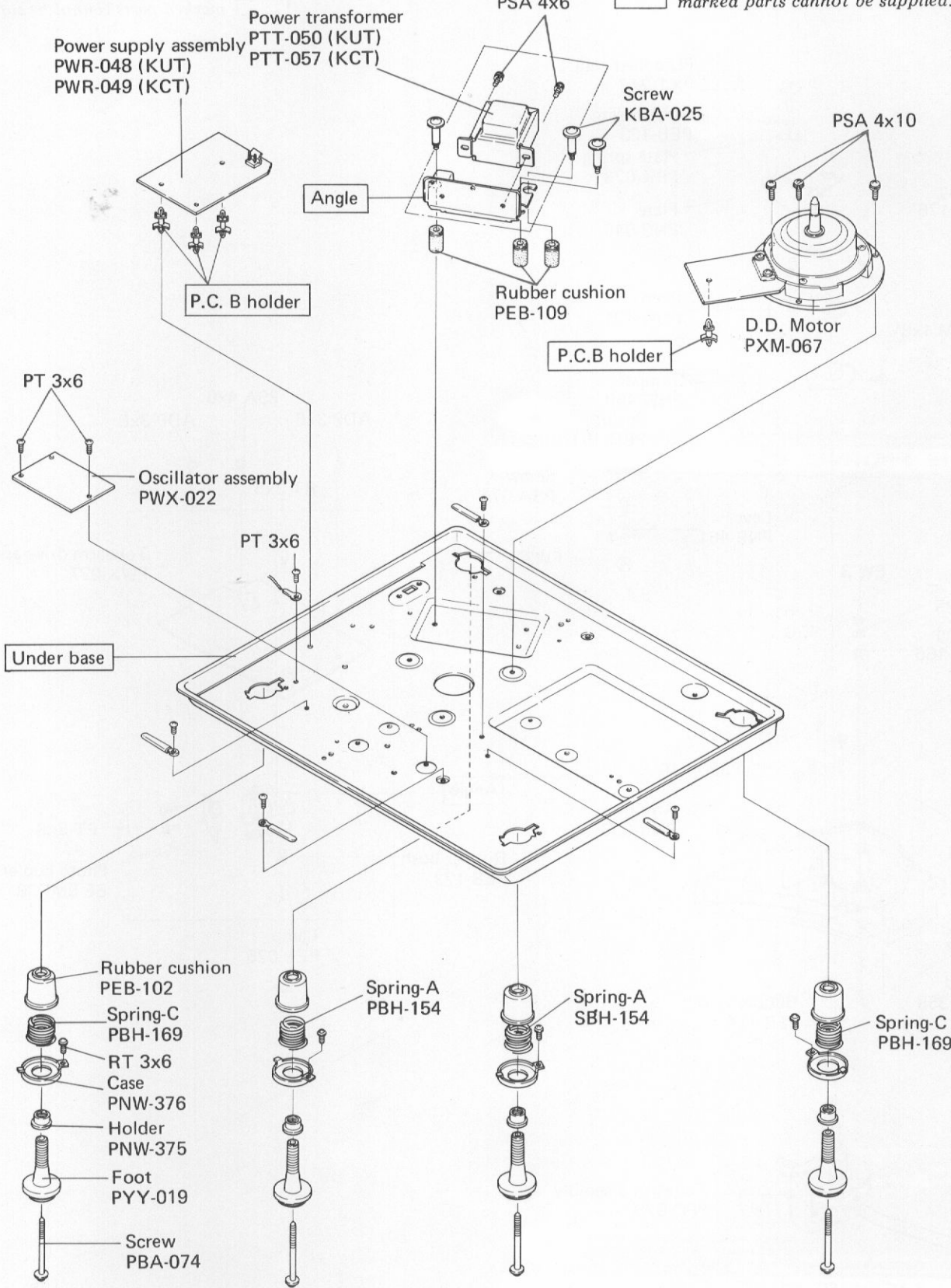

1

2

3

6.5 D.D. MOTOR (PXM-067)

Include Oscillator Assembly PWX-022

NOTE:
[] marked parts cannot be supplied.

A

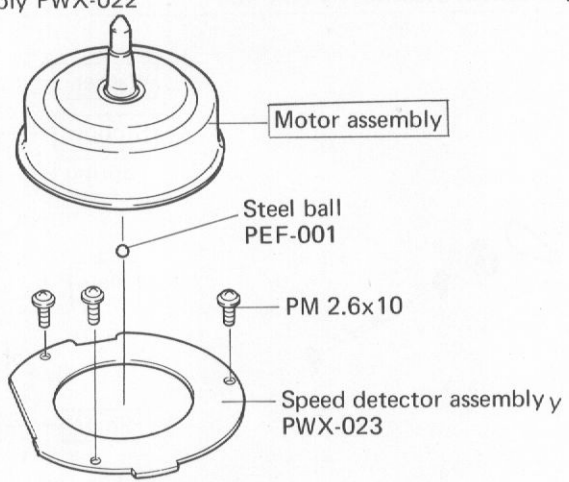

A

B

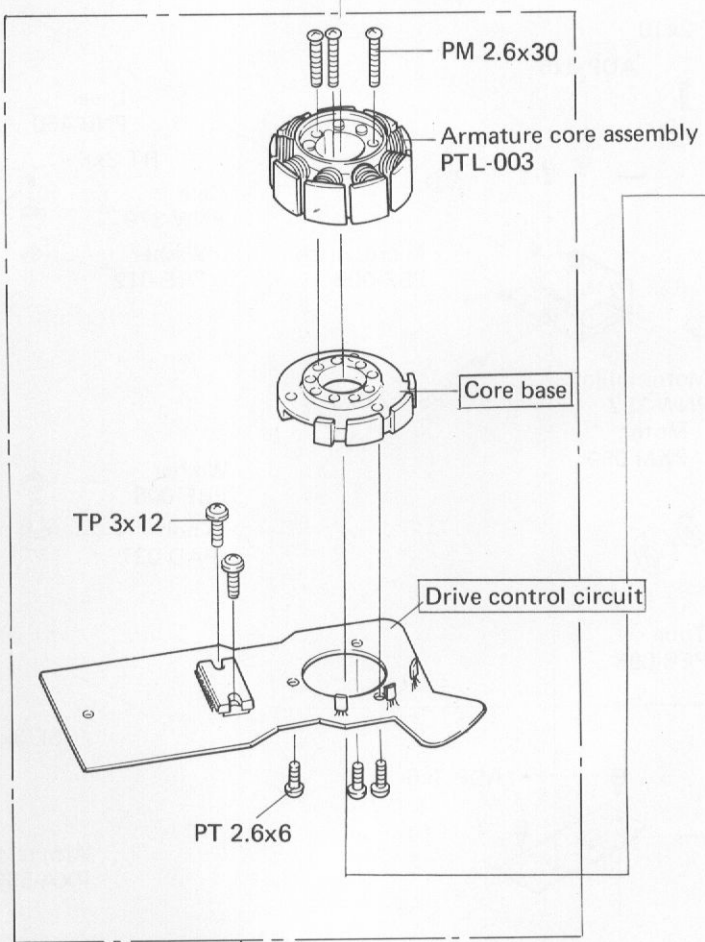

B

C

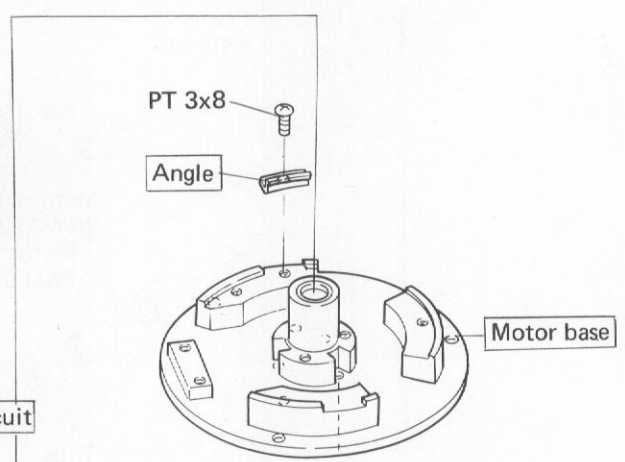

C

D

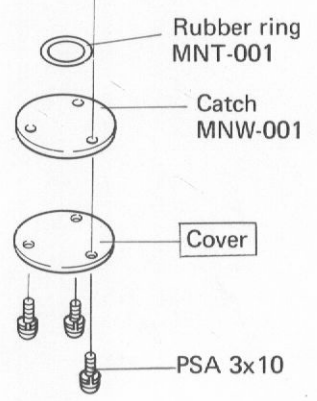

D

1

2

3

6.6 PACKING

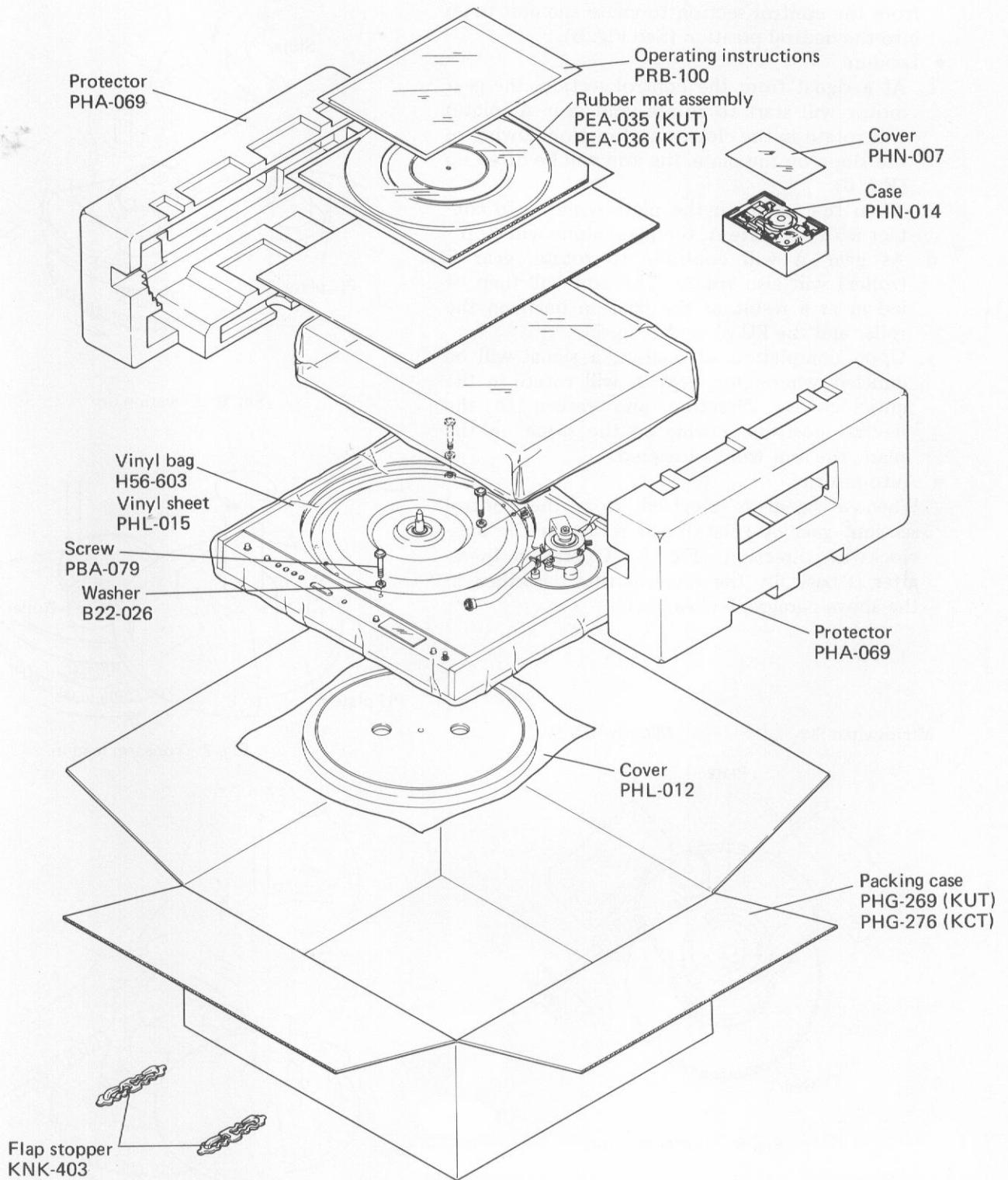

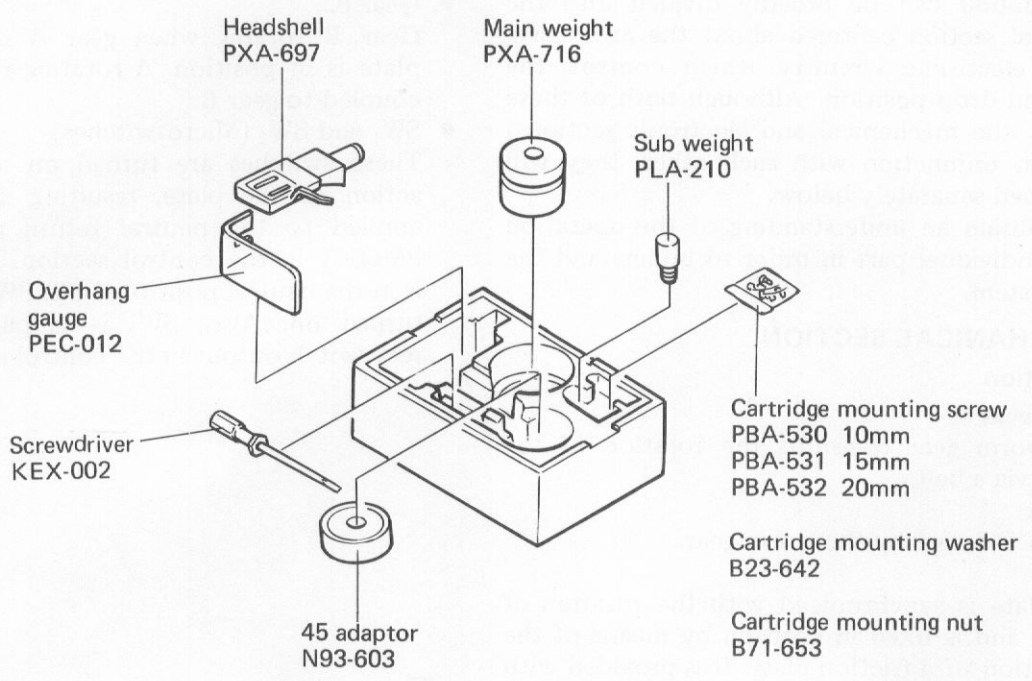

7. DESCRIPTION OF OPERATION

The PL-630 can be broadly divided into the mechanical section centered about the arm drive, and the electronic circuitry which controls the lead-in and drop position. Although both of these parts (i.e. the mechanical and electronic sections) operate in conjunction with each other, they will be described separately below.

First obtain an understanding of the operation of each individual part in order to understand the overall system.

7.1 MECHANICAL SECTION

Construction

- Worm gear
The worm gear transmits the rotation of the motor via a belt.
- Gear A
Gear A is driven by the worm gear.
- Plate
The plate is synchronized with the rotation of gear A and is fixed in position by means of the slip action of a friction plate. It is provided with an UP-DOWN slope for arm elevation.

- Gear B
Gear B rotates when gear A rotates and the plate is in position. A rotating roller is directly coupled to gear B.
- SW₁ and SW₂ (Microswitches)
These switches are turned on and off by the action of the plate, resulting in signals being applied to the neutral return part of the IC PM6001 in the control section. When the unit is in the neutral position, both SW₁ and SW₂ will be turned on. Also, SW₂ is in parallel with the rest switch output in the control section.

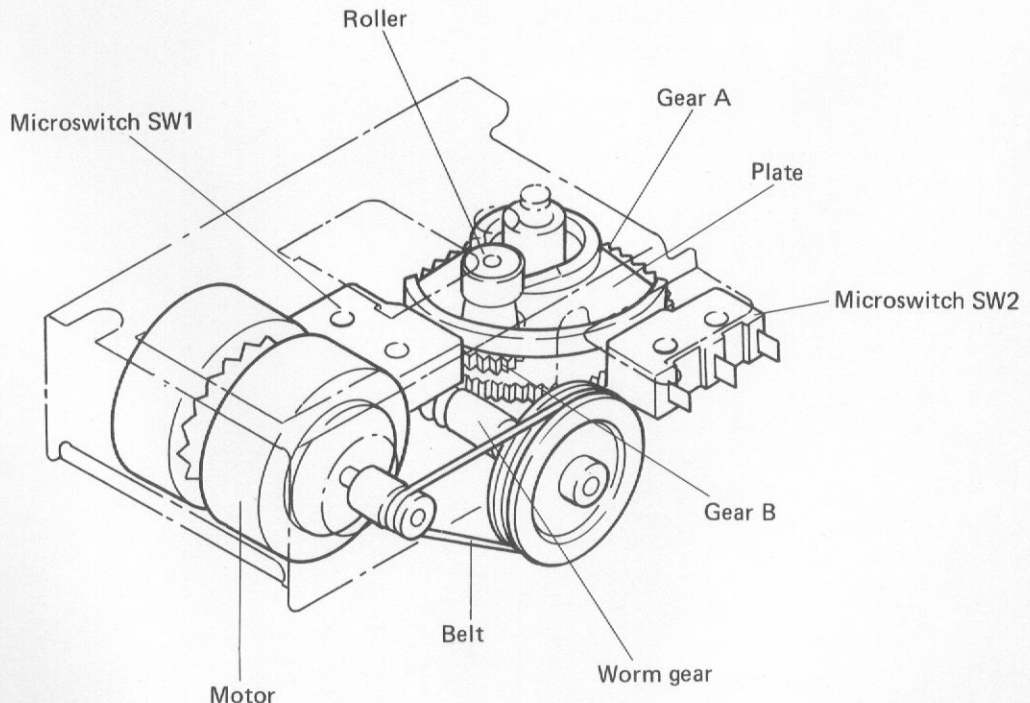

Fig. 4 Construction

Operation

- Neutral position

If the unit is not in the neutral position when the power is turned on, a signal will be emitted from the control section to cause the unit to go into the neutral position (See Fig. 5).

- Lead-in

1. At a signal from the control section, the gear motor will start to rotate, and gear A (plate) will rotate in the clockwise direction. Owing to the slope on the plate, the arm will be lifted up (Fig. 6).
2. When the roller on the plate comes into contact with PU plate A, the plate alone will stop.
3. As gear A will continue to rotate, gear B (roller) will also rotate. The arm will then be led in as a result of the friction between the roller and the PU plate A (Fig. 7).
4. Upon completion of lead-in, a signal will be emitted whereupon gear A will rotate in the anticlockwise direction and return to the neutral position. Owing to the slope on the plate, the arm will be lowered.

- Auto-return

When a signal is received from the control section, gear A (plate) will rotate in the anticlockwise direction (Fig. 8). Operation thereafter is basically the same as that described in the above paragraph (Lead-in).

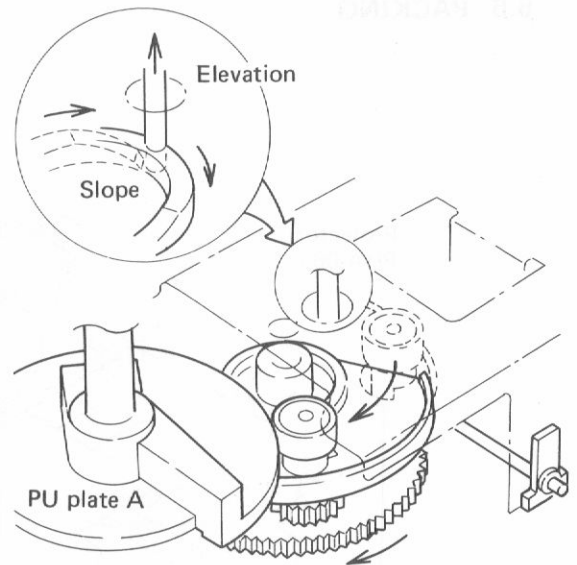

Fig. 6 Elevation up

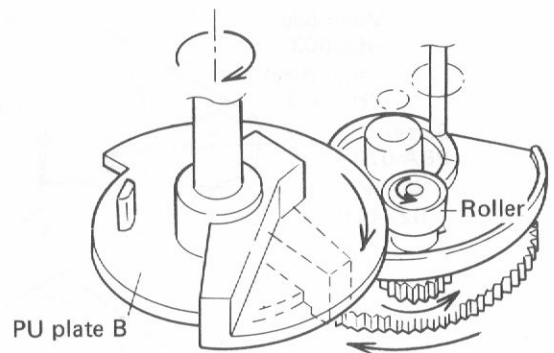

Fig. 7 Tonearm lead in

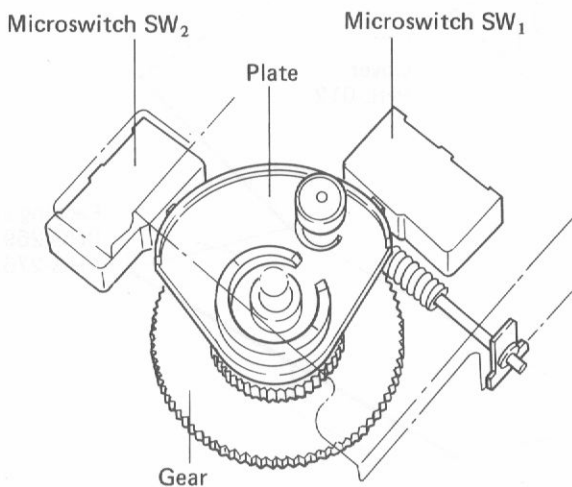

Fig. 5 Neutral position

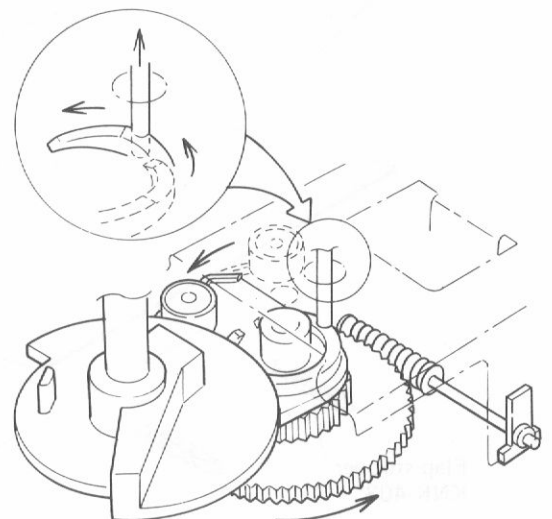

Fig. 8 Elevation down

7.2 CONTROL SECTION (ELECTRICAL SECTION)

Construction

The control section consists of 2 ICs which process signals inputted from the various detection and operation units to control the mechanical section. Details of the detection units are given diagrammatically for each item.

Detection Units

- Lowering position sensor (photo-coupler)

1. This sensor consists of an LED and a PTR (photo-transistor) located on either side of PU plate B.
2. When the arm moves, PU plate B will also move, and as a result light from the LED will pass through the slit in PU plate B to turn on the PTR.

- End detector sensor

1. When the stylus tip moves to within 62mm from the center shaft of the player, light from the lamp which was blocked by PU palte B will strike the CdS cell.
2. The output voltage from the CdS cell will become proportionately larger as the stylus tip moves towards the inner groove. This voltage change will be applied to the end detector part of the IC to permit detection of the lead-out groove.

- Rest switch

1. When the arm is in the rest position, the light from the lamp will be prevented from striking the PTR by means of the light shield on PU plate B.
2. When the arm moves towards the center shaft, light will strike the PTR. The PTR output will become the phono-motor START signal in the case of manual operation, or will become the signal used to detect the return of the arm to the rest position during automatic operation.

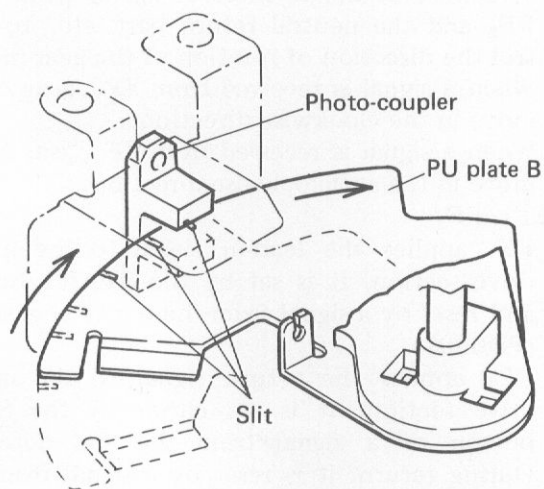

Fig. 9 Lowering position sensor

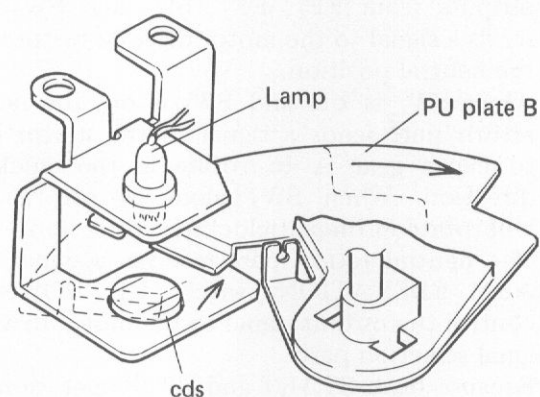

Fig. 10 End detector sensor

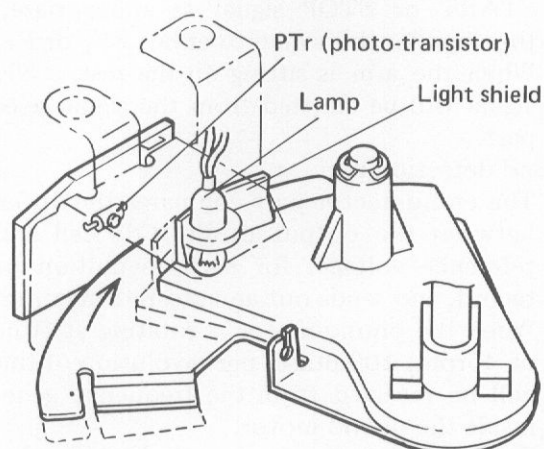

Fig. 11 Rest switch

IC PM6001

- Motor drive part
 1. This part of the IC receives signals from FF_1 , FF_2 and the neutral return part, etc., to control the direction of rotation of the gear motor.
 2. When a signal is received from FF_1 , gear A will move in the clockwise direction.
When a signal is received from FF_2 , gear A will move in the anticlockwise direction.
- FF_1, FF_2
 1. FF_1 applies the lead-in signal to the motor drive section. It is set by the START button and reset by a signal from the parity check part (PD6001).
 2. FF_2 applies the return signal to the motor drive section. It is set either by the STOP button or a signal from the end detector. During return, it is reset by a signal from the parity check part.
- Neutral return part
 1. The neutral return part receives the various outputs from FF_1 , FF_2 , SW_1 and SW_2 , and sends a signal to the motor drive to restore it to the neutral position.
 2. When SW_1 is off and SW_2 is on, the neutral return part sends a signal to the motor drive to cause gear A to rotate in the clockwise direction. When SW_2 alone is off, gear A will rotate in the anticlockwise direction.
 3. The neutral return part receives a signal from ARM ELEVATION switch (UP, DOWN) to control the output signal to the motor drive.
- Signal selection part
 1. Because both START and STOP operations are performed by the same button, the signal selection part looks at the signal which comes in from the rest switch, turns it into either a START or STOP signal as appropriate, and then applies this signal to either FF_1 or FF_2 .
 2. When the arm is sitting on the rest, a START signal will be emitted from the signal selection part.
- End detection part
 1. The end detector part compares the difference between the output of the CdS cell and the reference voltage, for each revolution of the record, and sends out an auto-return command.
 2. When the phono-motor is rotating at either 33 or 45rpm, 100 pulses per revolution of the disc will be received from the frequency generator inside the phono-motor.
 3. The end detector part will be reset by the first pulse, and will start to compare the output from the CdS cell with the reference

voltage, for each revolution of the record, commencing from the 100th pulse. When the change in the output of the CdS cell exceeds the reference voltage, the end detector part will send out an auto-return command.

- EV control part
 1. When the arm is about to be raised, the EV control part will prevent the operation of the neutral return part and also send an UP signal to the motor drive part.
 2. The motor drive part will cause gear A to rotate in the clockwise direction, in the same manner as during lead-in. The plate will stop the instant that SW_1 is put on.
 3. Owing to the slope of the plate, the arm will be raised up.
 4. When the arm is about to be lowered, the operation blockage will be removed from the neutral return part. As a result, gear A will rotate in the anticlockwise direction to lower the arm.

IC PD6001

- Counter part
 1. This part counts the number of signals (number of times that PU plate B slips) received from the lowering position sensor, and sends an output to the part.
 2. The counter part is always reset during both start and auto-return.
 3. During lead-in, the '30cm' slit is counted as the first slit and the '17cm slit' as the third slit. Conversely, during auto-return, the '17cm slit' is counted as the first slit and the '30cm' as the third slit.
 4. During return, the counter only operates when the repeat switch is on.
- Manual size selector
 1. The manual size selector records the size of the record on the turntable by means of a signal received from the record size selector button, and sends an output signal corresponding to the particular size to the lowering position selector/turnover part.
 2. Once a particular record size has been selected, this information will be retained until the next time the selection button is pressed.
- Lowering position selector/inversion part
- * Lowering position selector part
 1. The lowering position selector part receives the record size signal sent from the manual size selector, and determines the arm lowering position for each size.

2. The lowering position in the case of a 30cm record will be No.1, and for a 17cm record will be No.3. The output from the lowering position selector part will be applied to the parity check part.

* Inversion part

3. The inversion part operates only during auto-reverse. It makes the lowering position selection the reverse of that for lead-in.

4. In other words, the lowering position in the case of a 30cm record will be No.3, and for a 17cm record will be No.1.

• Parity check part

1. The parity check part compares the signal (output from inversion part) from the lowering position selection part with the output of the counter. If both values coincide, a reset signal will be sent to FF₁ and FF₂.

• Repeat control part

1. When the REPEAT button is pressed, the repeat control part instructs the counter to operate during return.

IC Block Diagram

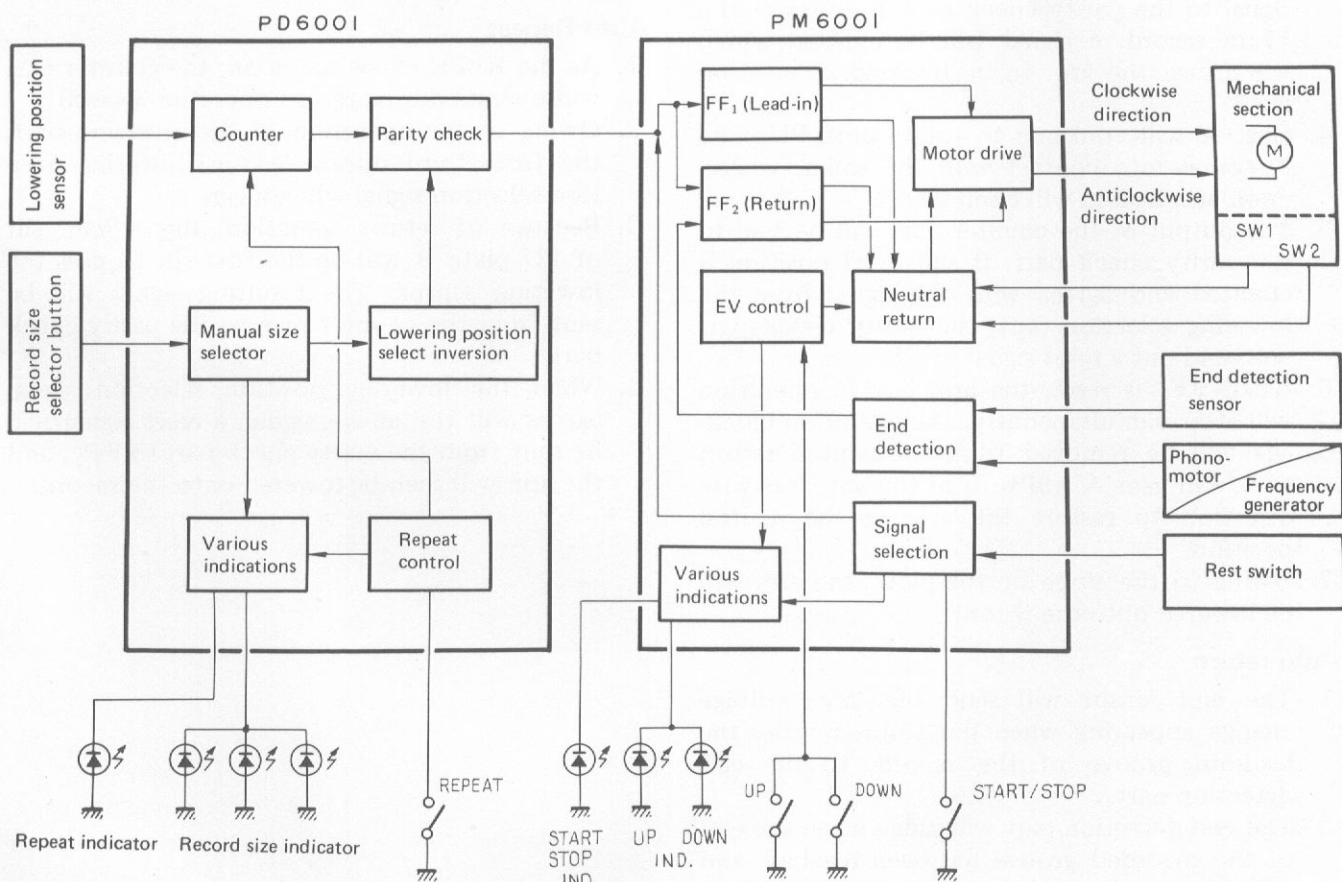

This block diagram has been abbreviated in order to facilitate understanding of the basic operation.

7.3 ACTUAL OPERATION (17cm record)

Auto-lead-in

1. When the START button is pressed, the neutral return part will be prevented from operating, and FF_1 will be set. FF_1 will send an arm lead-in signal to the motor drive part, and the gear motor will start to rotate.
2. The gear motor will rotate gear A in the clockwise direction, and turn off SW_2 . This will cause the phono-motor to start up. Simultaneously, the slope on the plate will cause the arm to be raised up.
3. As a result of the signal sent from the record size selector button, the lowering position selector part (The inversion part will not operate.) will send the tone-arm lowering position signal to the parity check part. In the case of a 17cm record, a signal will be emitted which will cause the arm to be lowered at position No.3.
4. Gear A will continue to rotate until PU plate A comes into contact with the roller, whereupon arm lead-in will commence.
5. The output of the counter part will be sent to the parity check part. If the third position is counted and agrees with the signal from the lowering selection part, the parity check part will send out a reset signal to FF_1 .
6. When FF_1 is reset, the arm lead-in operation will stop. Simultaneously, the operation blockage will be removed from the neutral return part, and gear A will turn in the anticlockwise direction to restore the arm to the neutral position.
7. Owing to the slope on the plate, the arm will be lowered onto the record.

Auto-return

1. The end sensor will send the large voltage change appearing when the stulus reaches the lead-out groove of the record, to the end detection part.
2. The end detection part will judge when the end of the recorded groove has been reached, and will then send a reset signal to FF_1 and an operation inhibit direction to neutral return part.
3. FF_2 will send a return directive to the motor drive part, as a result of which gear A will start to rotate in the anticlockwise direction. As a result of the slope of the plate, the arm will be raised up. After the roller comes into contact with PU plate A, the arm will be returned to the arm rest.

4. When the arm returns to the arm rest, the output from the rest switch will cause FF_2 to be reset. Simultaneously, the operation inhibit condition will be removed from the neutral return part.
5. Gear A will return to the neutral position and the arm will be lowered, thus completing operation.

Auto-stop

1. If the START/STOP is pressed during play, the signal selection part will send out a STOP signal.
 2. The above STOP signal will cause FF_2 to be set, thus commencing return operation.
- For details of subsequent operation see previous section entitled "Auto-return".

Auto Repeat

1. As the REPEAT switch is on, the counter part will operate during return operation as well.
2. Owing to the operation of the inversion part, the first (third during lead-in) lowering position selection signal will appear.
3. Because of return operation, the '17cm' slit of PU plate B will be the first slit to pass the lowering sensor. The resulting signal will be sent from the counter part to the parity check part.
4. When the lowering position selection signal agrees with the above signal, a reset signal will be sent from the parity check part to FF_2 , and the arm will then be lowered onto the record.

8. ADJUSTMENT

8.1 STYLUS LOWERING POSITION

1. Remove the rubber bush behind the tone-arm.
2. Check to see if the lowering position error is inside or outside the true position.
3. Place the tone-arm on the arm rest and turn the adjusting screw using a Phillips head screwdriver.
4. If the positioning error is inside the true position, turn the adjusting screw anticlockwise, and vice versa.

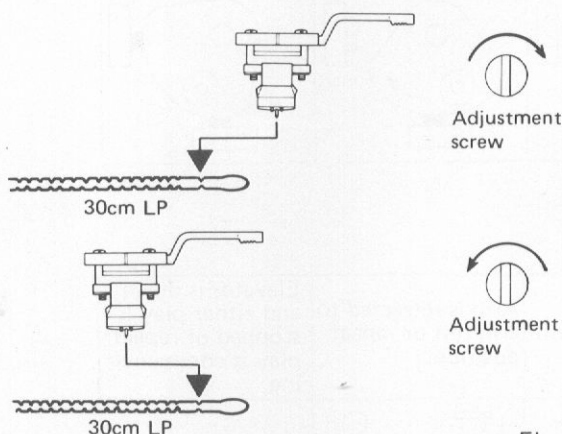

Fig. 12

8.2 ADJUSTMENT OF D.D. MOTOR OPERATING POINT

• Adjustment conditions

Connect the SP and TP₂₃ terminals of PWG-017 to each input of a double image oscilloscope (synchroscope). Put the turntable in the Quartz Lock ON condition, and then start it up.

• Method of adjustment

1. Observe the output waveforms from SP and TP₂₃ (Fig. 13). (Two output pulses from terminal TP₂₃ will correspond with one pulse from terminal SP).
2. Adjust the semi-fixed resistor in the drive control assembly (PWG-017) so that the rising part of the pulse which comes out of terminal TP₂₃ fits into the middle of the pulse which is generated at terminal SP. For 33-1/3 rpm, adjust VR₂₁. For 45 rpm adjust VR₂₂.

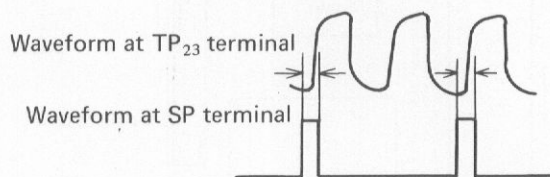

Fig. 13

8.3 SPEED ADJUSTMENT WHEN QUARTZ LOCK IS OFF

1. Put the quartz lock off.
2. Turn the ADJUST knob on the control panel to the mechanical center position.
3. Insert a screwdriver through the small hole in the baseplate of the player, and turn the semi-fixed speed adjustment potentiometer VR₁ until the strobe pattern on the turntable becomes stationary.

8.4 SENSITIVITY ADJUSTMENT OF CdS CELL

• Adjustment conditions

1. Remove the turntable and the top cover.
2. Ensure that the separation between the CdS cell and PU plate B is 2.5 to 3.5mm, and that between the CdS cell and the lamp is 10mm.
3. Connect the positive terminal of a voltmeter to terminal 3 of the Tonearm Drive assembly (PWX-027), and the negative terminal to terminal 5 of the same board.
4. Ensure that terminal 4 of the secondary board is grounded (by connecting it to terminal 5).
5. Take care to ensure that no other light, apart from that of the lamp, strikes the CdS cell.

• Method of adjustment

1. Press the POWER switch on, raise the arm elevator and move the tonearm to the innermost groove on the record.
2. Adjust VR₁ on the Tonearm Drive assembly (PWX-027) so that the voltmeter indication lies between 12.5 and 13.1V.

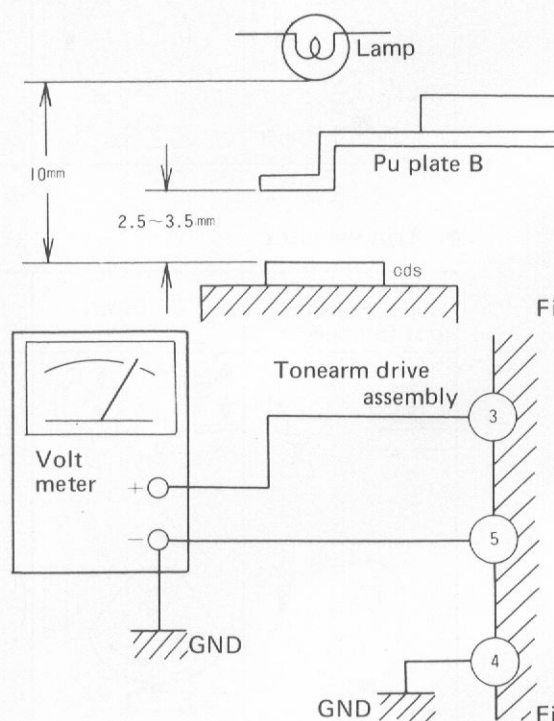
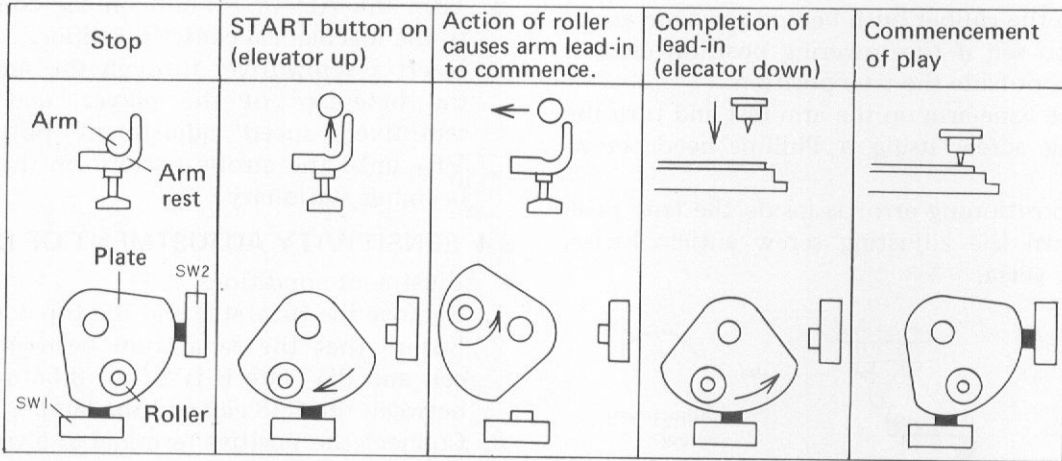

Fig. 14

Fig. 15

7.4 ACTUAL OPERATION OF MECHANICAL SECTION

- Automatic lead-in



- Auto-return (Auto-repeat)

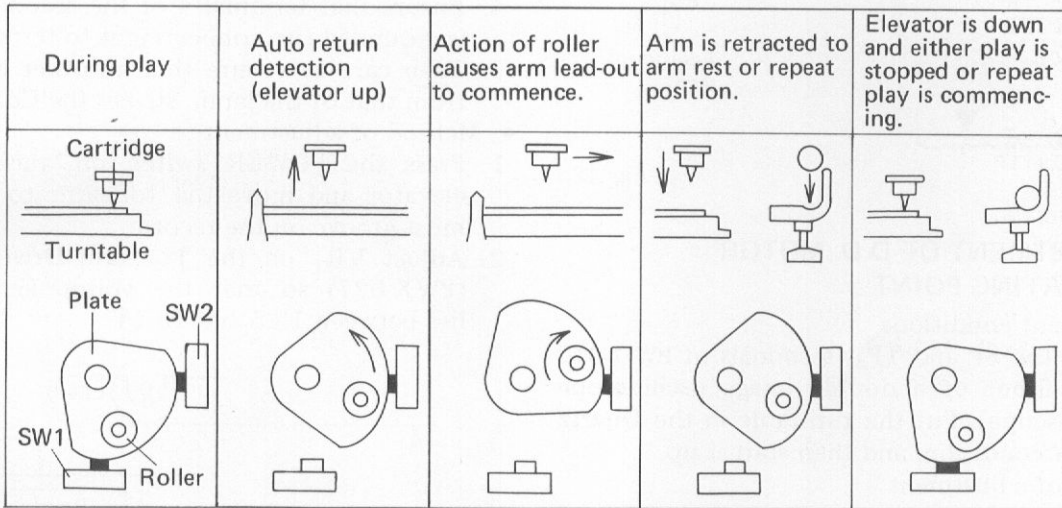

- Arm elevator

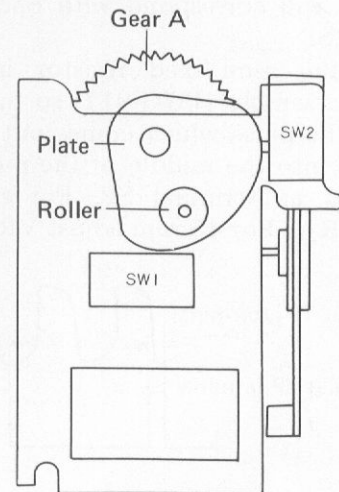
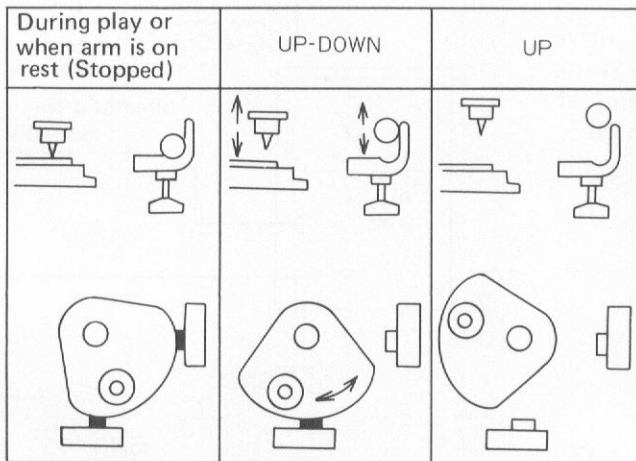

8.5 METER ADJUSTMENT

- Adjustment conditions

1. Connect a frequency counter between the TP₁ and Gnd terminals of the oscillator assembly (PWX-022).
2. Turn the speed adjust knob to its mechanical center.
3. Put the Quartz Lock off.

- Adjustment

1. Put the speed selector button in the "45" position.
2. Turn VR₁ in the oscillator assembly (PWX-022) until the reading on the frequency counter becomes 750.0Hz.
3. Turn VR₂ in the control (B) assembly (XWX-007) until the meter reading becomes zero.
4. Put the speed selector button in the "33" position, and turn VR₁ until the meter reading becomes zero.
5. Turn the speed adjust knob until the reading on the frequency counter becomes 795Hz (750Hz +6%).
6. Adjust VR₃ so that the meter indication becomes +6%.

9. D.D. MOTOR CIRCUIT DESCRIPTIONS AND TROUBLE SHOOTING

9.1 BLOCK DIAGRAM

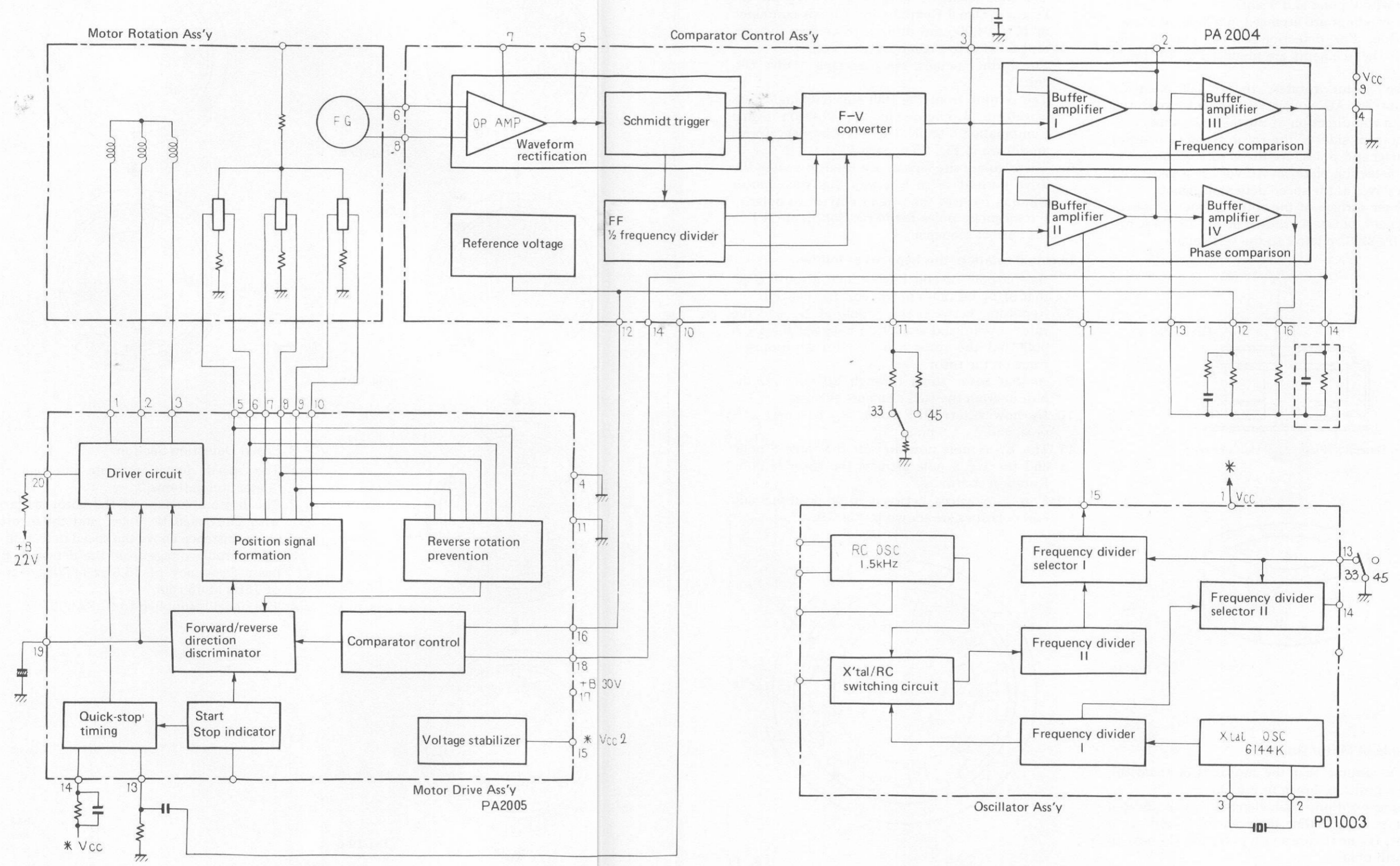

9.2 MOTOR OPERATION

1 Motor Construction

1. The PXM-067 is an outer-rotor brushless DC motor with 6 poles and 9 slots.
2. Motor windings are arranged in a 3-phase Y configuration. For detection of the platter position, 3 Hall elements are mounted at 40° intervals.
3. As the motor rotates, these Hall elements generate an AC voltage dependent upon the strength and direction of the magnetic flux.
4. The bottom side of the rotor magnet possesses 200 magnetic poles. As these rotate above the speed detection plate, an AC voltage is generated which serves as the speed detection signal.
5. The inner surface of the rotor magnet possesses 6 magnetic poles. As shown in Fig.17, these are tilted by 22.0° relative to the vertical axis.

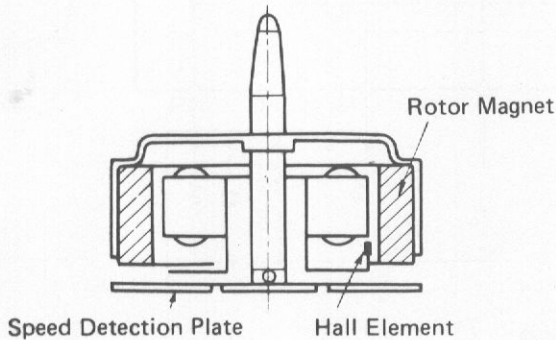

Fig. 16

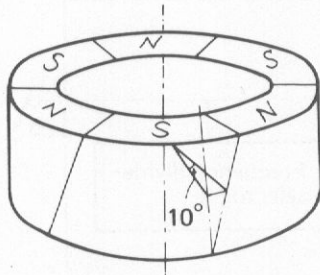

Fig. 17

2. Principle of Motor Rotation

1. Let us assume that the motor is at standstill, in the position shown in Fig. 3.
2. In this position, Hall element H_A is located next to a borderline between south and north poles, H_B next to a south pole, and H_C next to a north pole.

3. When the unit is switched on, the output voltages of the respective Hall elements will be as shown in Fig. 25-a, page 47.
4. The Hall element output is applied to the Position Signal Combination Circuit contained in IC PA-2005 and utilized to control the current flowing to the motor drive coils. For further details, see paragraph "Drive Circuit."
5. The output from the Hall elements undergoes waveform formation in the Position Signal Combination circuit. The resulting waveforms are shown in Fig. 25-b, page 47.
6. These composite signals are used to switch the drive current in such a way that each motor winding receives the proper current to polarize the magnetic poles for north, south, or OFF in the correct sequence.

In actual rotation, this happens as follows.

7. As the pole of coil L_A becomes a south pole, that of L_B becomes north, and L_C , neutral.
8. Repulsion between the S pole at L_A and the rotor S pole, and attraction between the L_B N pole and the rotor S pole exert a propulsive force on the rotor.
9. As the rotor turns through 20° of arc, the output from the Hall elements changes.
10. L_B now enters OFF state, L_C becomes a N pole, and L_A a S pole.
11. The L_C N pole now attracts the rotor S pole, and the L_A S pole attracts the rotor N pole. Rotation continues.
12. Correspondences between rotor positions and coil polarities are shown in Fig. 19, a-f.

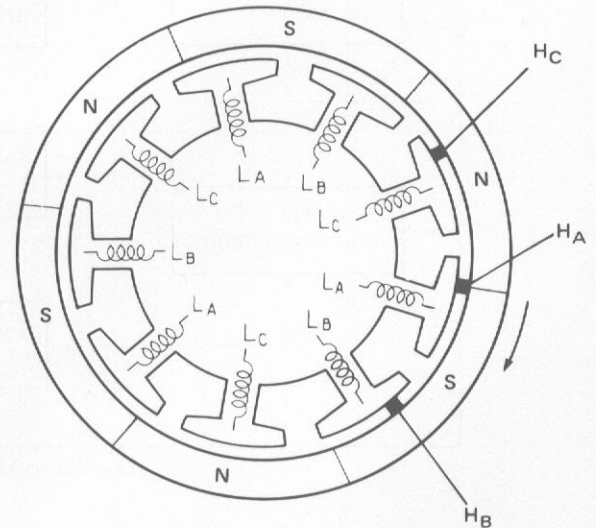

Fig. 18

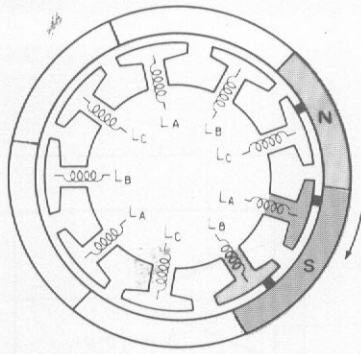

Fig. 19-a

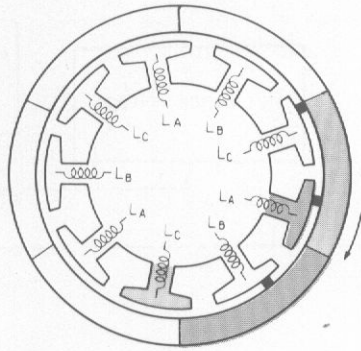

Fig. 19-b

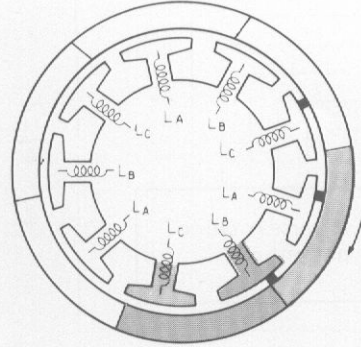

Fig. 19-c

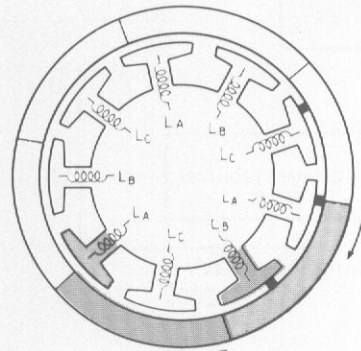

Fig. 19-d

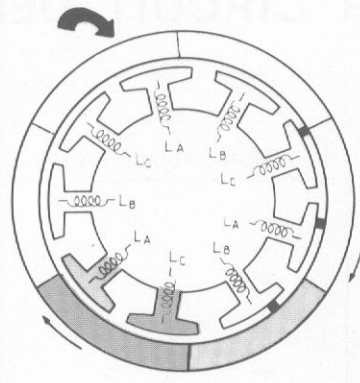

Fig. 19-e

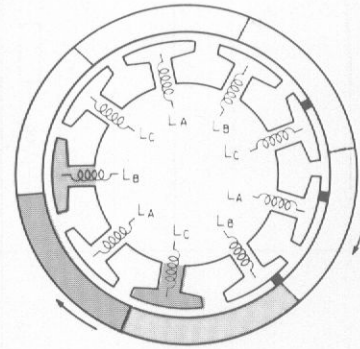

Fig. 19-f

3. Speed Detection Section

1. The speed detection plate has one rows of "detection patterns."
2. The bottom surface of the rotor is magnetized with 200 magnetic poles, and these rotate at a short distance above the speed detection plate.
3. The output voltage from the detection patterns has a frequency of 55.5Hz at 33-1/3 rpm, and of 75Hz at 45 rpm.
4. The signal is supplied to IC PA2004.

9.3 OPERATION OF THE PD1003 IC (OSCILLATOR STAGE)

1. Once the power supply is turned on, the quartz crystal oscillator generates a 6144kHz signal.
2. The frequency of this signal is reduced to 1.5kHz (1/4096 division) by frequency divider I. Part of the resultant signal is passed via the x'tal/RC switching circuit and applied to frequency divider II. The other part of the signal is applied to frequency divider selector II.
3. The 1.5kHz signal applied to frequency divider II is further divided into a 750Hz signal, and applied to frequency divider selector I where the signals are converted into sampling pulses for phase comparison purposes in PA2004.

33rpm 27.78Hz

45rpm 37.5Hz

(In both cases, the pulse width is 0.667ms).

4. Frequency divider selector II converts signals from frequency divider I into pulse signals for the stroboscope lamp drive circuit.

33rpm 55.5Hz

45rpm 75.0Hz

(In both cases, the pulse width is again 0.667ms).

5. The oscillation frequency (1.5kHz) of the RC o.s.c. block can be varied by $\pm 6\%$ with the SPEED ADJ control.
6. Since the reference signal is varied with the SPEED ADJ at Quartz Lock OFF, the speed of the turntable is also variable $\pm 6\%$.

9.4 OPERATION OF THE PA2004 IC (COMPARATOR CONTROL)

1. Signals from the frequency generator in the motor rotation ass'y are changed into 50% duty square wave signals by the waveform rectifier. The frequencies at this stage are thus,

33rpm 55.55Hz

45rpm 75Hz

2. Part of the output is divided by $\frac{1}{2}$ in the FF circuit, and subsequently applied to the FV converter circuit along with the other part of the output formed in step 1 above, thereby forming the FV converter gate pulse signals.
3. The output from the FV converter is applied to buffer amplifiers I and II.
4. The buffer amplifier I output is compared with the reference voltage in buffer amplifier III, and then applied to the output compose circuit.
5. Phase comparison of the sampling pulses from the PD1003 IC with the FV converter output occurs in buffer amplifier II, with the resultant output being applied to buffer amplifier IV.
6. The output from buffer amplifier IV is also applied to the output compose circuit.

7. This output compose circuit consists of a low-pass filter (cut-off frequency 23Hz, cut-off slope -6dB/oct.) which serves to eliminate the carrier component in the output of buffer amplifier II (phase comparison).
8. This final output signal is then passed onto the comparator control stage of the PA2005 IC for comparison with the reference voltage.

9.5 OPERATION OF THE PA2005 IC (DRIVE CONTROL)

• Start/stop indicator stage

1. The input signal to this stage is applied by means of an external start/stop switch. In the PL-630, this switch is a photo-transistor switch activated by tonearm movement.
2. If the switch is turned on when the motor is stationart, a start signal is generated, and is used to start up the drive circuit.
3. If the switch is turned on when the motor is rotating, the forward/reverse direction discriminator circuit will be notified of the subsequent generation of a reverse torque.
4. At the same time, a stop signal is applied to the quick-stop timing circuit.

• Quick stop timing circuit

1. The motor will rapidly stop as a result of the reverse torque generated by the stop signal.
2. When the turntable speed drops, the signal of Fig. 10-b will appear at the quick stop timing circuit (Pin 13 of PA2005).
3. As a result of this signal, the waveform at pin 14 of PA2005 will become as shown in Fig. 10-c.
4. When the motor speed falls off, the signal level at pin 14 of PA2005 will exceed the fixed value, whereupon the drive circuit will go off.
5. Subsequently, the turntable will continue to rotate under its own inertia for a brief interval and then stop.

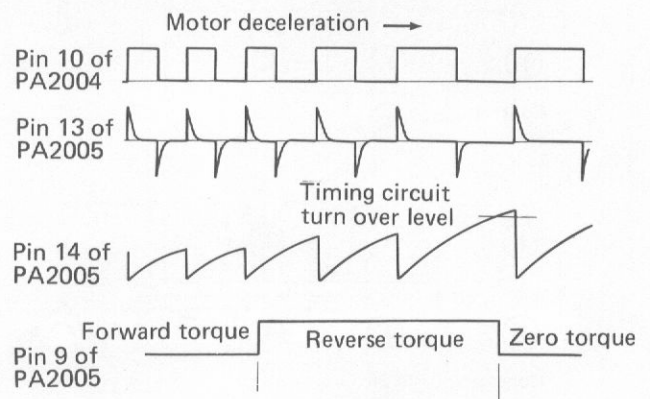

Fig. 20

● Stroboscope Pulse Circuit

1. The platter has only a single row of stroboscopic markings. Switchover for 45 and 33 rpm is effected by changing the frequency of the pulse to the stroboscopic lamp.
2. From the Frequency Divider Selector I, a frequency of either 75Hz (for 45 rpm, representing 1/80 of 6000Hz) or 55.5Hz (for 33 rpm, representing 1/108) is obtained and supplied to the transistor that drives the stroboscopic lamp.

● Reverse Rotation Prevention

1. PXM-061 operates indiscriminately in regard to the direction of rotation. If the platter is turned slowly in the reverse direction by hand, a forward torque will be applied until the platter stops, reverses its rotation and reaches rated speed in the proper direction.
2. If, however, the rotational speed in the reverse direction is in excess of 33 or 45 rpm, the Forward/Reverse Command Block may "mis-read" this as simply excessive speed ("overrun") and apply a reverse torque until rated speed is attained.
3. This reverse torque will further accelerate the turntable rotation in the reverse direction. This is known as "reverse run-away."
4. To prevent this from happening, a Reverse Rotation Prevention circuit has been included.
5. This Reverse Rotation Prevention circuit consists of two flip-flops and AND gates See Fig. 21.
6. The input for this circuit is derived from the Hall element position detection signals processed in the Reverse Rotation Prevention circuit.
7. As long as the platter is rotating in the proper direction, this pulse enters in the order B - A - C, and no "reverse" command is generated.
8. If, however, the platter rotates in the reverse direction, the pulse order becomes A - B - C, and a corrective command is given to the Forward/Reverse Command Circuit.

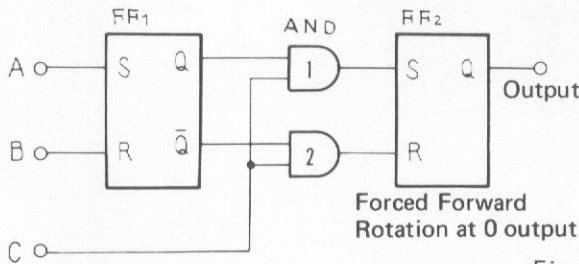

Fig. 21

	FF ₁					C	AND		FF ₂
		S	R	Q	\bar{Q}		1 _{out}	2 _{out}	
Forward rotation	B	0	1	0	1	0	0	0	
	↓								
	A	1	0	1	0	0	0	0	
Reverse rotation	↓								
	C	0	0	1	0	1	1	0	1
	↓								
Reverse rotation	A	1	0	1	0	0	0	0	
	↓								
	B	0	1	0	1	0	0	0	
Reverse rotation	↓								
	C	0	0	0	1	1	0	1	0

Truth table

● Comparator Control and Forward/Reverse Command Circuit

1. Two inputs are supplied to the Control Comparator: a) a 4V reference voltage from the voltage stabilizer; and b) the output from the active filters, which serves as the detection signal.
2. If the turntable rotates faster than rated speed, the detection signal is higher than the 4V reference.
3. When this happens, the Comparator Control sends a command to the Forward/Reverse Command Circuit, telling it to apply a reverse torque to the motor to slow it down.
4. Conversely, if turntable rotation is below rated speed, the detection signal voltage will be below the 4V reference.
5. In this case, the Comparator Control indicates to the Forward/Reverse Command Circuit that forward torque must be applied to the motor to accelerate it.

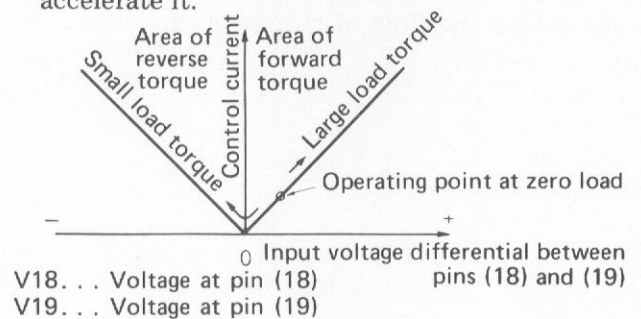

Fig. 22

● Drive Circuit

1. The signals employed in the switching of Q2 ~ Q7 in Fig. 23 are generated by 3 Hall elements, and applied to terminals a, b, and c via the position signal formation circuit.
2. The phase of these step waveform signals is displaced by 120° from each other.
3. When the step waveform signals at position I in Fig. 24-a are applied to the drive circuit terminals a, b, and c, the potential at terminal a will be lowered, resulting in Q2 being turned on. The potential at terminal b will be raised, resulting in Q6 being turned on, but the potential at terminal c will remain at the reference level voltage (the bias settings for Q4 and Q7 have been designed to prevent these 2 transistors from operating when a reference level voltage is applied).
4. Vcc will thus be applied across the Q2 - coil L_A - coil L_B - (2) - Q6 route, thereby producing an S polarity in L_A , and an N polarity in L_B .
5. Once the magnetic field is generated, the rotor will commence to rotate. After the rotor turns through 20° , the signals at position II in Fig. 24-b will be applied to terminals a, b, and c, thereby resulting in a change in the flow routes of the drive currents. After the rotor turns through another 20° , the signals shown at position III in Fig. 24-c will be applied, again resulting in changes in flow routes of the drive currents. For every 20° that the rotor turns through, the flow routes for the drive currents will change as shown in Figs. 24-d, 24-e, and 24-f, finally returning to the routes shown in Fig. 19-a again.
6. A control voltage generated by the forward/reverse direction discriminator indicator circuit is applied to the control input terminal, thereby controlling the flow of current in the coils.

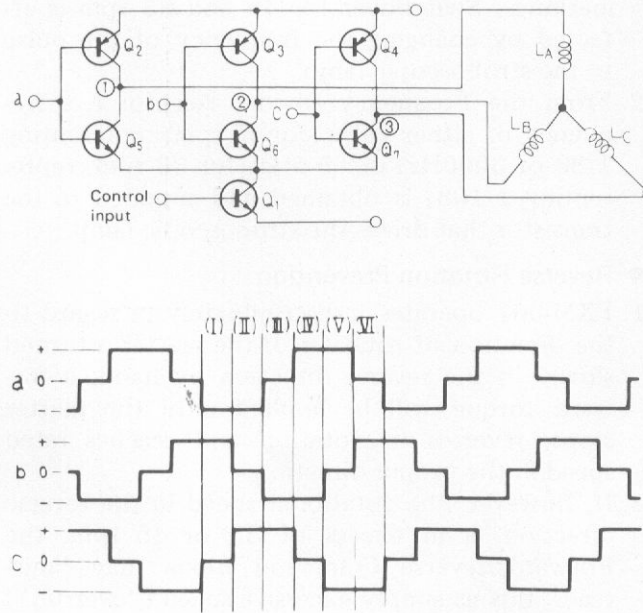

Fig. 23

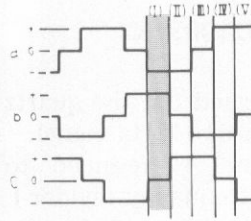
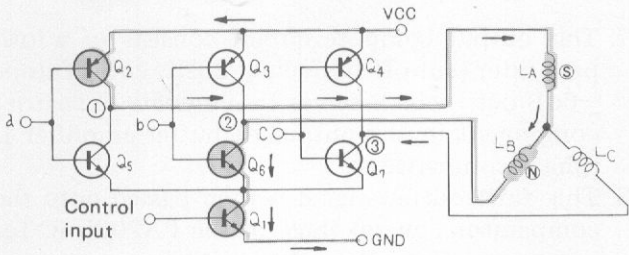

Fig. 24-a

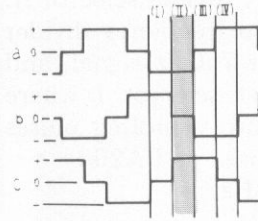
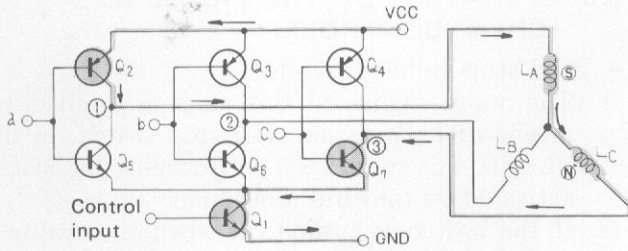

Fig. 24-b

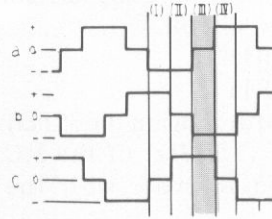
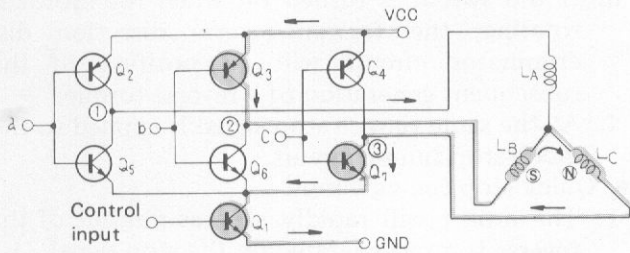

Fig. 24-c

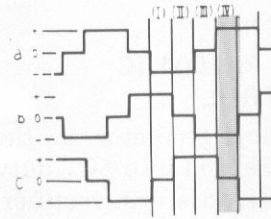
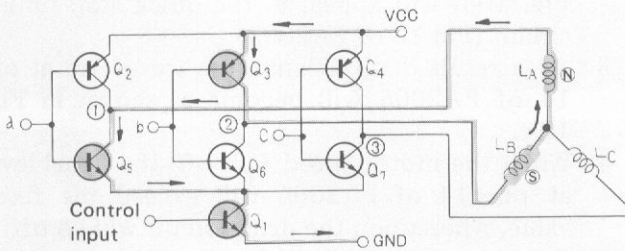

Fig. 24-d

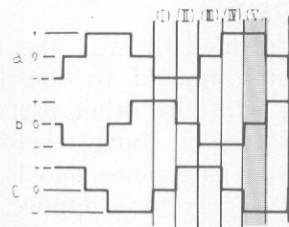
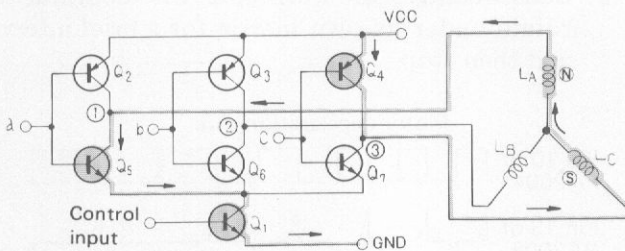

Fig. 24-e

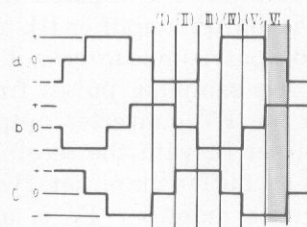
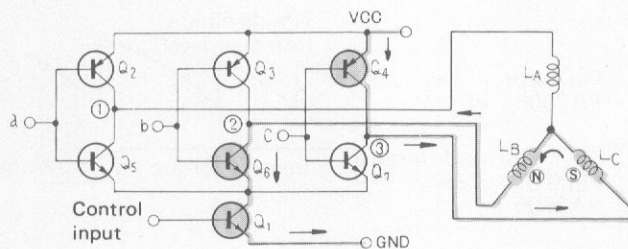
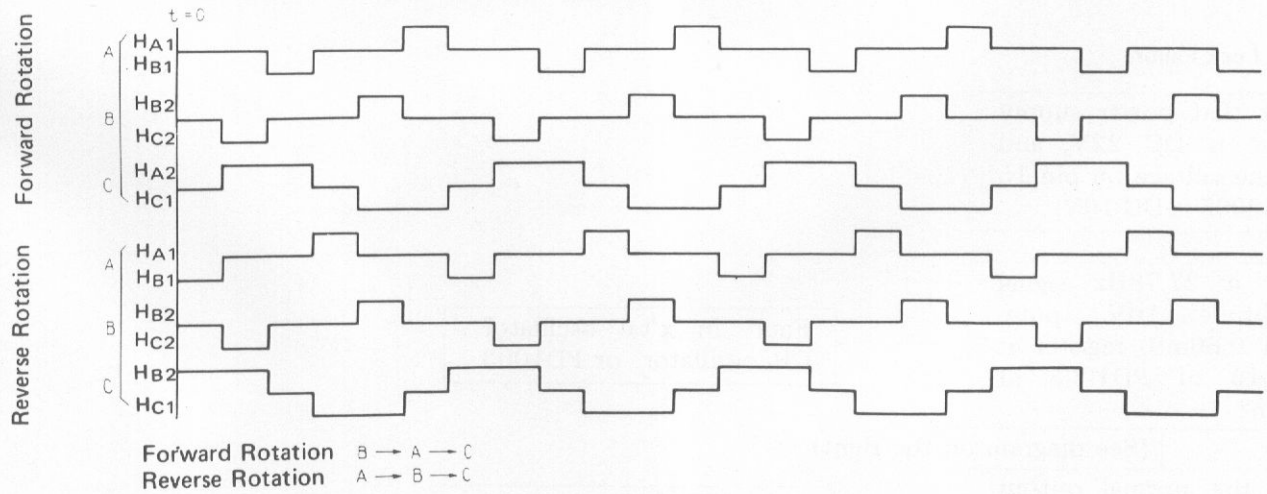
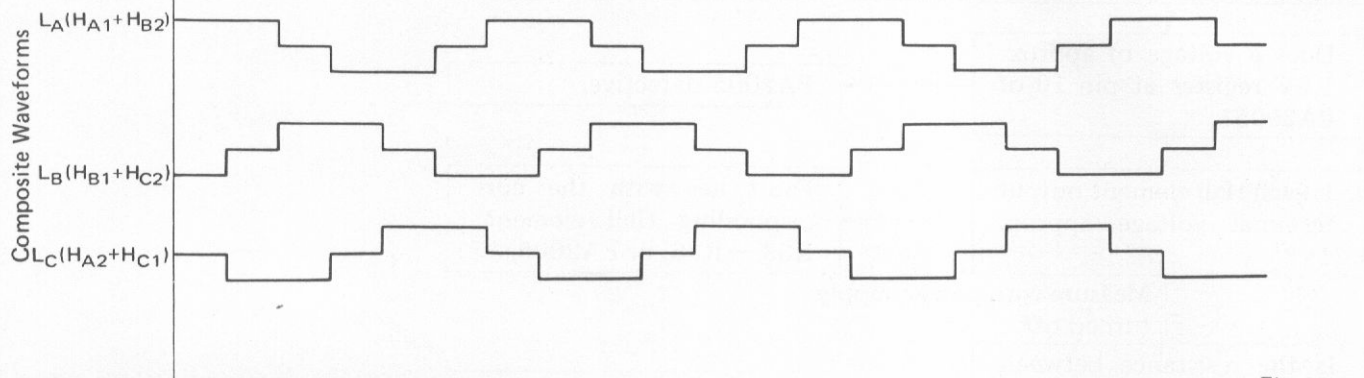
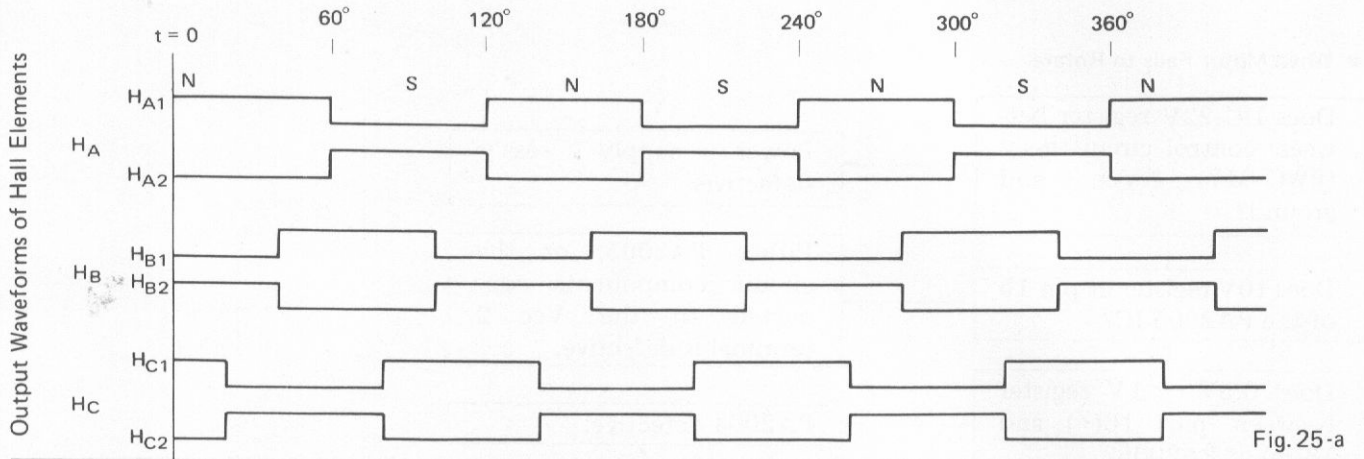
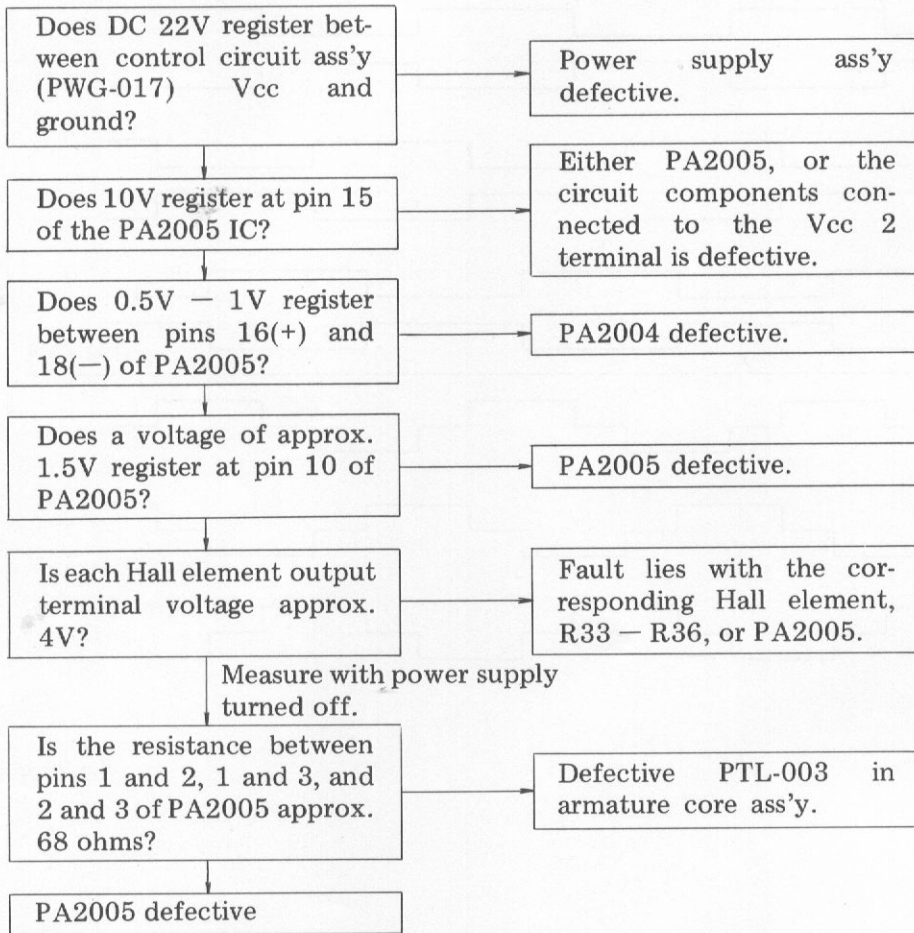

Fig. 24-f



9.6 TROUBLE SHOOTING CHART

● When Motor Fails to Rotate



● Phase Lock Failure

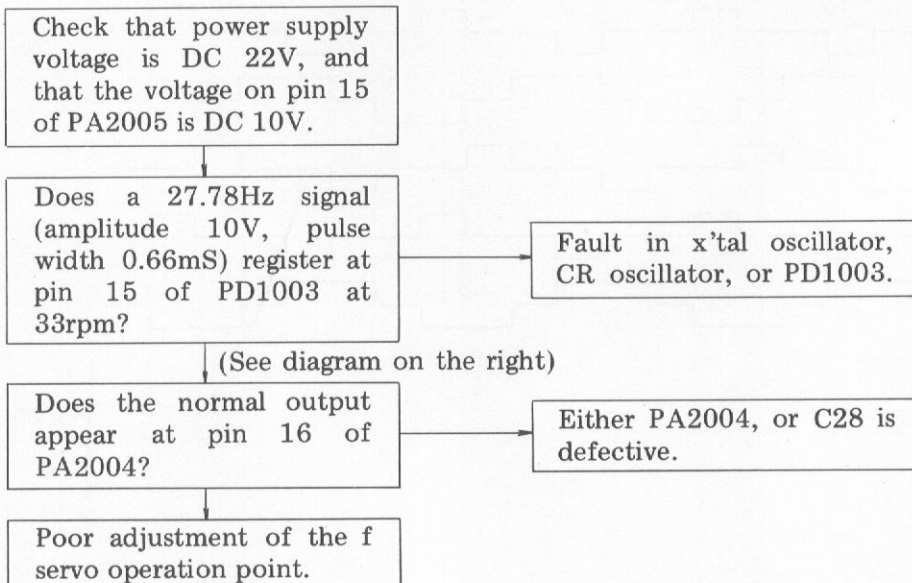

● Motor Runaway

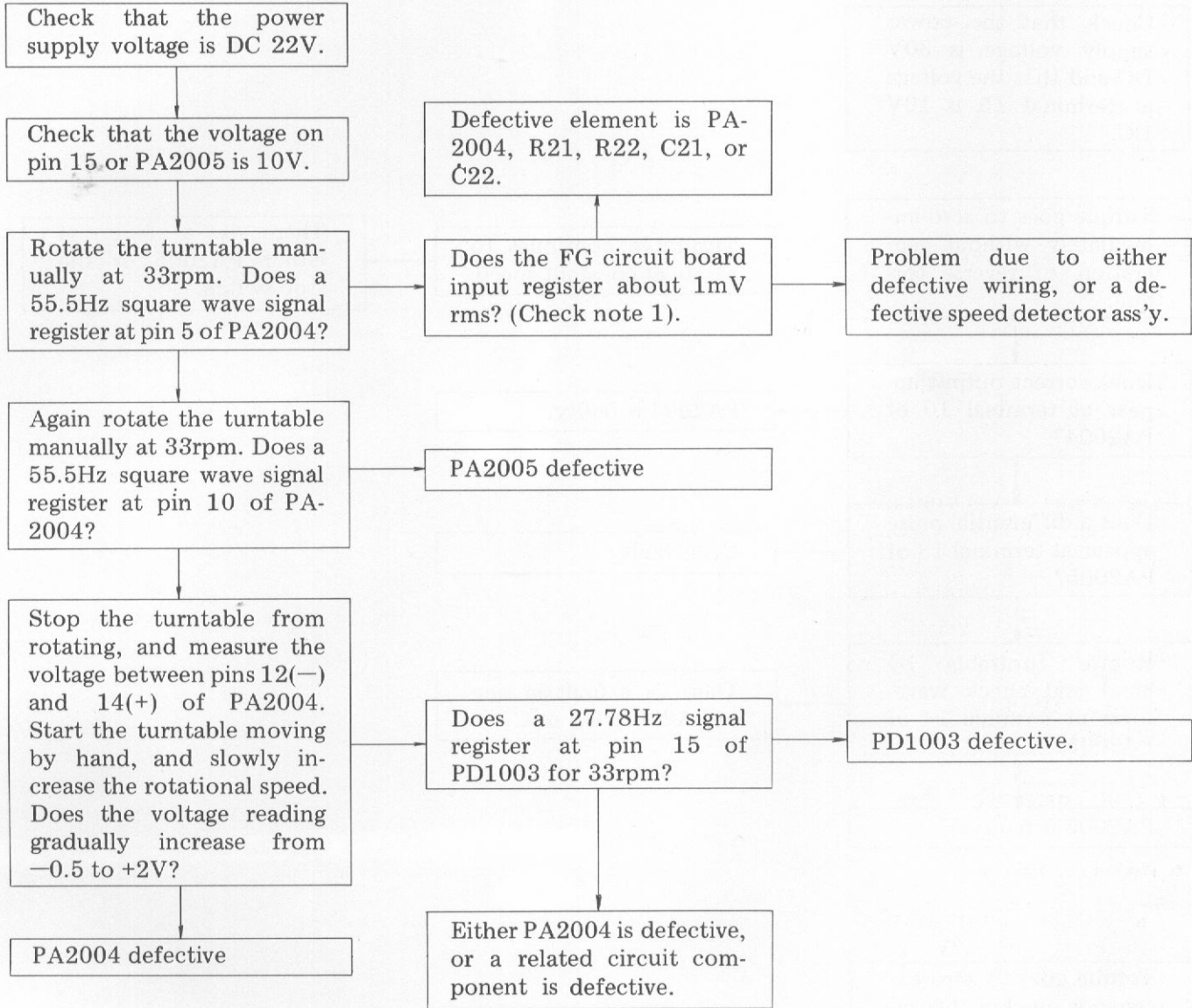

*Note 1. Connect a 100 μ V/10V capacitor between TP22 and ground.

• Quick stop operation faults (Stop switch ON)

