

 **PIONEER®**

# Service Manual

**CIRCUIT & MECHANISM  
DESCRIPTIONS  
REPAIR & ADJUSTMENTS**



**ORDER NO.  
ARP-530-0**

**STEREO TURNTABLE**

# PL-750

**MODEL PL-750 COMES IN FIVE VERSIONS DISTINGUISHED AS FOLLOWS:**

Type	Voltage	Remarks
KU	AC 120V only	U. S. A. model
KC	AC 120V only	Canada model
R	AC 110V ~ 120V and 220V ~ 240V (Switchable)	General export model
WEM	AC 220V ~ 240V	Europe model
WP	AC 220V ~ 240V	Australia model

- This service manual is applicable to the PL-750/KU type.
- For servicing the PL-750/KC, R, WEM and WP types, please see pages 28, 29.
- Ce manuel d'instruction se réfère au mode de réglage en français.
- Este manual de servicio trata del método de ajuste escrito en español.

## CONTENTS

1. SPECIFICATIONS .....	2	9. BLOCK DIAGRAM .....	17
2. PANEL FACILITIES .....	3	10. CIRCUIT DESCRIPTIONS .....	18
3. DISASSEMBLY .....	4	11. ADJUSTMENTS .....	19
4. EXPLODED VIEWS .....	6	RÉGLAGES .....	21
5. ELECTRICAL PARTS LIST .....	11	AJUSTES .....	23
6. PACKING .....	12	12. PRECAUTIONS FOR REASSEMBLY .....	25
7. P. C. BOARDS CONNECTION DIAGRAM .....	13	13. FOR PL-750/KC, R, WEM AND WP TYPES ...	28
8. SCHEMATIC DIAGRAM .....	15	14. SAFETY INFORMATION .....	29

**PIONEER ELECTRONIC CORPORATION** 4-1, Meguro 1-Chome, Meguro-ku, Tokyo 153, Japan  
**PIONEER ELECTRONICS (USA) INC.** P.O. Box 1760, Long Beach, California 90801 U.S.A.  
TEL: (800) 421-1404, (213) 420-5914  
**PIONEER ELECTRONIC [EUROPE] N.V.** Keetberglaan 1, 2740 Beveren, Belgium TEL: 03/775-28-08  
**PIONEER ELECTRONICS AUSTRALIA PTY. LTD.** 178-184 Boundary Road, Braeside, Victoria 3195, Australia  
TEL: (03) 580-9911



## 2. PANEL FACILITIES

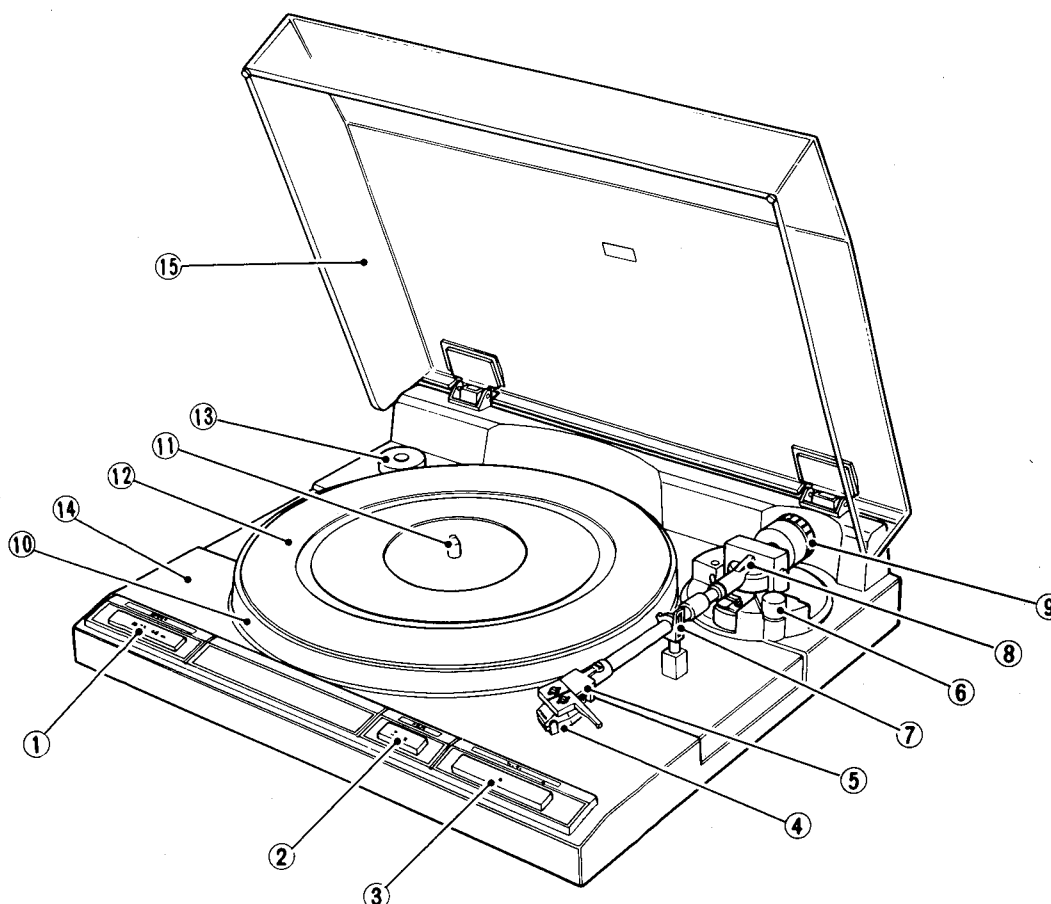

### ① SPEED SWITCH

Set this switch in accordance with the speed of the record which is to be played.

[33] (released position): For 33-1/3 rpm records.

[45] (depressed position): For 45 rpm records.

### ② ARM ELEVATION SWITCH

- Use the switch for manual operation.
- Use the switch to suspend record play temporarily.
- Use the switch when changing the tracks during actual play.

Depressed position:

The tonearm rises (the stylus moves away from the record).

Released position:

The tonearm descends (the stylus is lowered onto the record).

### ③ CUT SWITCH

Press this switch to stop play.

### ④ CARTRIDGE (PC-5MC)

### ⑤ HEADSHELL

### ⑥ ANTI-SKATE CONTROL

This is rotated when performing the anti-skating adjustment.

### ⑦ ARM REST

This serves to hold and clamp the tonearm. When moving the tonearm, release the clamp.

### ⑧ TONEARM

### ⑨ TRACKING FORCE ADJUSTMENT WEIGHT

This is used when adjusting the tracking force.

### ⑩ PLATTER

### ⑪ PLATTER SHAFT

### ⑫ RUBBER MAT

### ⑬ EP ADAPTER

This is used when playing records with a large center hole.

### ⑭ CABINET

### ⑮ DUST COVER



- **Mechanism Ass'y and Motor**

1. Turn on the turntable and free the mechanism.
2. Fasten the tone arm to the arm rest.
3. Remove the rubber sheet and turntable.
4. Close the player hood and turn the player upside down and place it on a soft cloth so that the player hood is not damaged.
5. Remove the seven screws ① , and remove the under base.
6. Remove five screws ② and one screw ③ .
7. Disconnect connectors ④ and ⑤ .  
The mechanism ass'y can be removed from the panel.
8. Remove the three screws ⑥ , and remove the motor.

See pages 25 to 27 for the parts installation and assembly precautions.

- **Tone Arm**

1. Remove the mechanism ass'y from the panel.
2. Using a soldering iron, disconnect the PU lead wires (arm lead wires) from the PU terminal board.
3. Remove the PU plate ass'y AS spring.
4. Remove the one screw ① , and remove the PU plate ass'y from the tone arm.
5. Remove the R clip.
6. Turn the player onto its side, remove the arm reset clamp, and remove the tone arm from the panel.

- **Power Transformer Ass'y**

- Remove the two screws ② .

# 4. EXPLODED VIEWS

## 4.1 EXTERIOR

### Parts List

**NOTES:**

- Parts without part number cannot be supplied.
- The  $\triangle$  mark found on some component parts indicates the importance of the safety factor of the part. Therefore, when replacing, be sure to use parts of identical designation.
- For your Parts Stock Control, the fast moving items are indicated with the marks **★★** and **★**.  
**★★ GENERALLY MOVES FASTER THAN ★**  
*This classification shall be adjusted by each distributor because it depends on model number, temperature, humidity, etc.*

Mark	No.	Part No.	Description	Mark	No.	Part No.	Description
	1.	PXB-321	Hinge assembly		31.	PBK-069	AS spring washer
	2.	PNV-049	Dust cover		32.	PNY-044	AS plate
	3.	PEA-067	Rubber mat assembly		33.	PBH-355	EV spring
	4.	PNR-187	Turntable platter		34.	YE50S	Washer
★★	5.	PXM-126	Motor		35.	PBH-339	Power lever spring
$\triangle$ ★	6.	PTX-042	Power transformer assembly		36.	PBH-374	Cut rod
$\triangle$	7.	PDF-206	AC power cord		37.	PNC-311	EV lever (A)
	8.	PEB-250	Rubber		38.	PLB-210	EV lever shaft
	9.	PBA-144	Screw		39.	PZD30P060FMC	Screw 3 x 6
	10.	PAD-139	SP button unit		40.	PBH-375	EV lever spring
	11.	PNY-155	Panel		41.	PNC-312	EV lever (B)
	12.	PAD-138	EV button unit		42.	PNY-130	EV lever (C)
	13.	PAD-137	S/S button unit	★★	43.	PSG-048	Push switch
	14.	XWS-021	Speed selector unit		44.	PEB-258	Insulator
	15.	PPZ30P080FMC	Screw 3 x 8		45.	PKB-059	R clip
$\triangle$	16.	PBA-169	Screw 3 x 25		46.	PXB-340	PU plate assembly
	17.	XWR-050	Power supply unit		47.	YS40FBT	Washer
	18.	IPZ30P100FMC	Screw 3 x 10		48.	WC40FMC	Washer
	19.	IPZ30P290FMC	Screw 3 x 29		49.	PNC-227	PU spring washer
	20.	PXV-068	EV sheet unit		50.	PMD40P100FMC	Screw 4 x 10
	21.	BPZ26P120FZK	Screw 2.6 x 12		51.	PBH-244	PU plate spring
	22.	PXB-332	Arm rest assembly		52.	PED-021	Cushion (A)
	23.	PAC-130	AS knob		53.	TMZ30P120FMC	Screw 3 x 12
	24.	PXB-563	Head shell		54.	YU30FUC	Nut
	25.	PPD-653	Tone arm assembly		55.	PNM-024	Shield plate
	26.	PXB-591 (PXB-583)	Weight assembly		56.	PBA-909	Cartridge mounting screw (W)
	27.	.....			57.	PXV-928	Cartridge (PC-5MC, without stylus)
	28.	PXB-345	PU cord assembly		101.		Under base
	29.	IPZ30P100FMC	Screw 3 x 10		102.		Rubber bush
	30.	PBH-292	AS spring		103.		PU plate A
					104.		PU plate B
					105.		Adjust cam
				$\triangle$	106.		Connector assembly (2P)
					107.		Sub-panel assembly

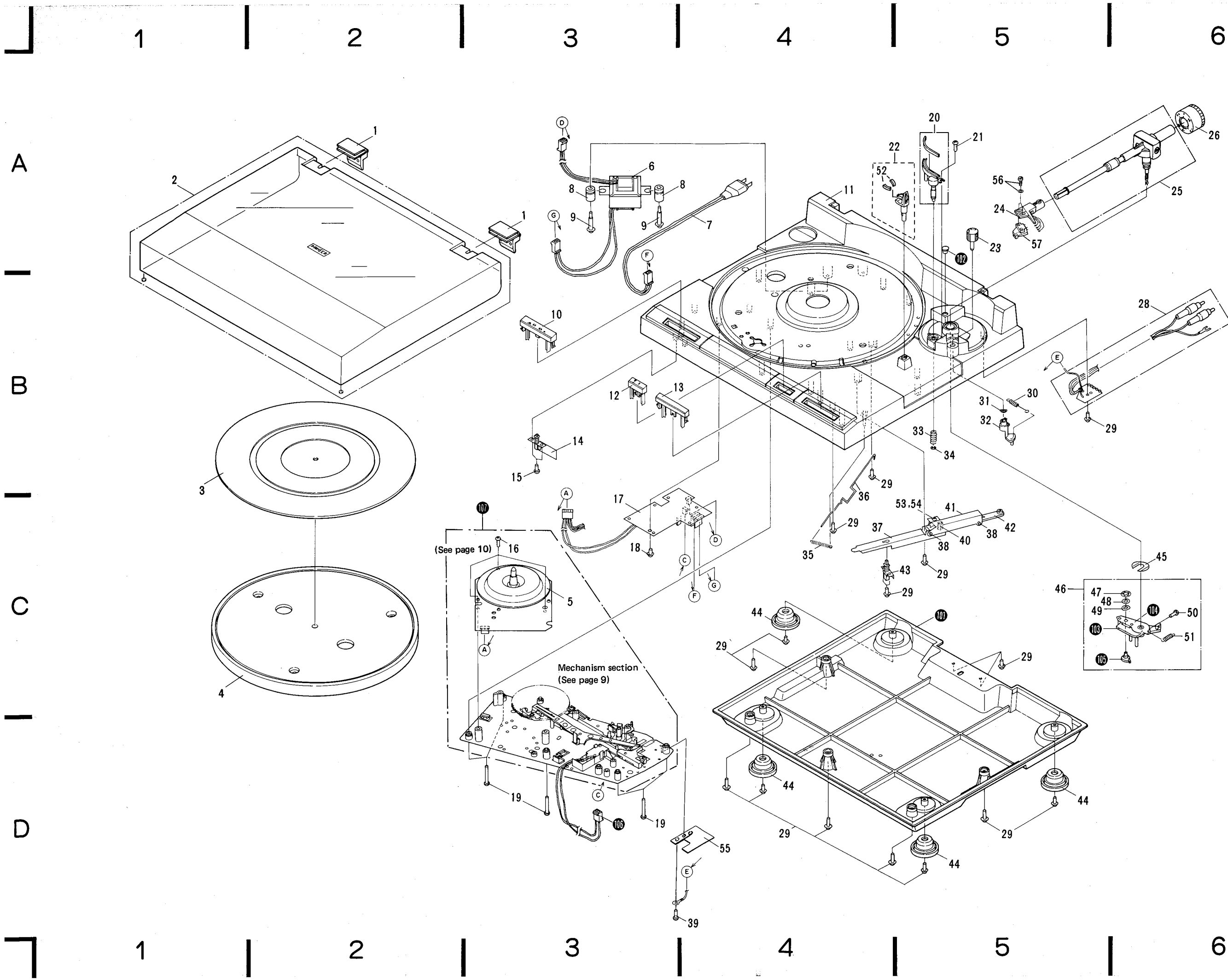

4.2 SUB-PANEL

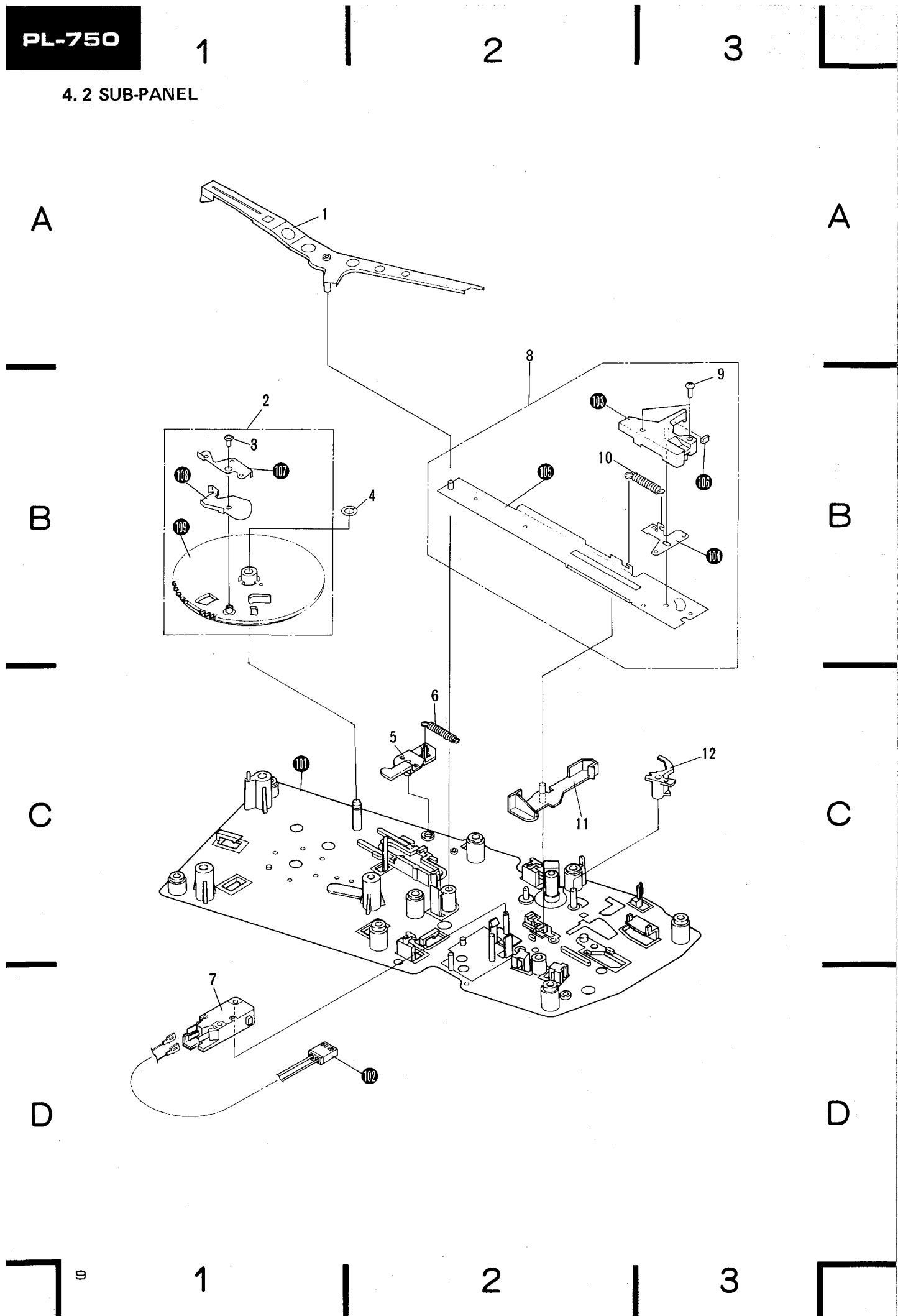

Parts List

Mark	No.	Part No.	Description	Mark	No.	Part No.	Description
	1.	PXT-446	Detector lever unit		101.		Sub panel unit
	2.	PYY-164	Cam assembly	△	102.		Connector assembly
	3.	PBA-126	Screw 2.6 x 8		103.		EV cam
	4.	PBF-018	Washer		104.		Start plate
	5.	PNY-139	Lock plate		105.		Drive plate unit
	6.	PBH-225	Lock plate spring		106.		EV cam buffer
△ ★ ★	7.	PSF-023	Microswitch		107.		Start plate
	8.	PXB-232	Drive plate assembly		108.		Signal plate
	9.	PMZ26P100FMC	Screw 2.6 x 10		109.		Cam
	10.	PBH-224	Start plate spring				
	11.	PNX-030	Switch lever				
	12.	PNY-141	Switch locker				
	13.						

4.3 D. D. MOTOR (PXM-126)

Parts List

Mark	No.	Part No.	Description
	1.	PXV-026	Rotor unit
	2.	PSZ30P050FMC	Screw 3 x 5
	3.		
	4.	PWM-139	Motor P. C. Board assembly
	51.		Spindle base unit
	52.		Base
	53.		Heat sink

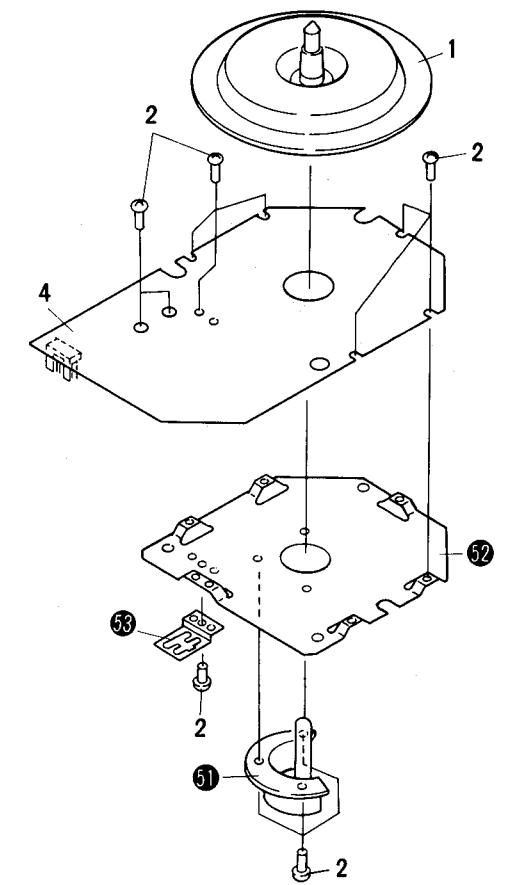



## 5. ELECTRICAL PARTS LIST

### NOTES:

- When ordering resistors, first convert resistance values into code form as shown in the following examples.

Ex. 1 When there are 2 effective digits (any digit apart from 0), such as 560 ohm and 47k ohm (tolerance is shown by J=5%, and K=10%).

560Ω	56 × 10 <sup>1</sup>	561 . . . . .	RD½PS	561 J
47kΩ	47 × 10 <sup>3</sup>	473 . . . . .	RD½PS	473 J
0.5Ω	0R5 . . . . .		RN2H	0R5 K
1Ω	010 . . . . .		RS1P	010 K

Ex. 2 When there are 3 effective digits (such as in high precision metal film resistors).

5.62kΩ	562 × 10 <sup>1</sup>	5621 . . . . .	RN½SR	5621 F
--------	-----------------------	----------------	-------	--------

- The  $\Delta$  mark found on some component parts indicates the importance of the safety factor of the part. Therefore, when replacing, be sure to use parts of identical designation.
- For your Parts Stock Control, the fast moving items are indicated with the marks **★★** and **★**.  
**★★ GENERALLY MOVES FASTER THAN ★**  
This classification shall be adjusted by each distributor because it depends on model number, temperature, humidity, etc.

### MISCELLANEOUS PARTS

#### P. C. BOARD ASSEMBLY

Mark	Part No.	Symbol & Description
$\Delta$	XWR-050	Power supply assembly
	XWS-021	Speed selector assembly
	PWM-139	Motor P.C. board assembly

#### OTHERS

Mark	Part No.	Symbol & Description
★★	PXM-126	Motor
$\Delta$ ★	PSF-023	S1 Microswitch
★	PSG-048	Push switch
$\Delta$	PDF-206	AC power cord assembly
	PXB-345	PU cord assembly
$\Delta$ ★	PTX-042	Power transformer

#### POWER SUPPLY ASSEMBLY (XWR-050)

#### SEMICONDUCTORS

Mark	Part No.	Symbol & Description
$\Delta$ ★★	2SD1275	Q1
$\Delta$ ★	PCX-010	D1
★	RD30EB4 (MZ-300) (WZ-300)	D2

#### CAPACITORS

Mark	Part No.	Symbol & Description
$\Delta$	CKDYE 103P 50	C1, C2
	CEA 331M 50L	C3
	CEA 470M 35L	C4
	CKDYF 103Z 50	C5
	CEA 100M 35L	C6

### RESISTOR

Mark	Part No.	Symbol & Description
	RS1PF222J	R1

### OTHERS

Mark	Part No.	Symbol & Description
	PDE-234	Connector assembly (6P)
	PDZ30P060FMC	Screw 3 x 6

#### SPEED SELECTOR ASSEMBLY (XWS-021)

#### SWITCH

Mark	Part No.	Symbol & Description
★★	PSG-050	S2 Push switch

### OTHERS

Mark	Part No.	Symbol & Description
	PDZ30P060FMC	Screw 3 x 6

#### MOTOR ASSEMBLY (PXM-126)

#### Motor P.C. Board Assembly (PWM-139)

#### SEMICONDUCTORS

Mark	Part No.	Symbol & Description
★★	PA2007	IC1
★★	PA2008	IC2
★★	PD1003	IC3
★	PCX-057	HA, HB Hall element

### CAPACITORS

Mark	Part No.	Symbol & Description
	CCDCH 330J 50	C1
	CQMA 123K 50	C5
	CQPA 473J 50	C8
	CKDYF 103Z 50	C2, C4, C9, C11
	CKDYF 223Z 50	C14 - C17

Mark	Part No.	Symbol & Description
	CCDCH 560J 50	C3
	PCL-046	C6, C7 (10/35)
	CEANL R22M 50	C18
	CEA R47M 50	C19
	CEA 010M 50	C12, C21
	CEA 100M 16	C10
	CEA 100M 35	C22 - C26
	CEA 101M 10	C13
	CSZA R22M 35	C20

### RESISTORS

NOTE: When ordering resistors, convert the resistance value into code form, and then rewrite the part no. as before.

Mark	Part No.	Symbol & Description
	RD1/2PS3R9J	R10
	RN1/4PR563G	R3
	RN1/4PR154G	R4
	RD1/4PM □□□ J	R1, R2, R5 - R9, R11 - R14
★	PCP-006	VR1 Semifixed 15k-B
★	PCP-072	VR2 Semifixed 47k-B

### OTHERS

Mark	Part No.	Symbol & Description
	SD-5045-06A	Connector 6P
	RNH-199	Terminal (GND)
★	PSS-003	Crystal resonator

## 6. PACKING

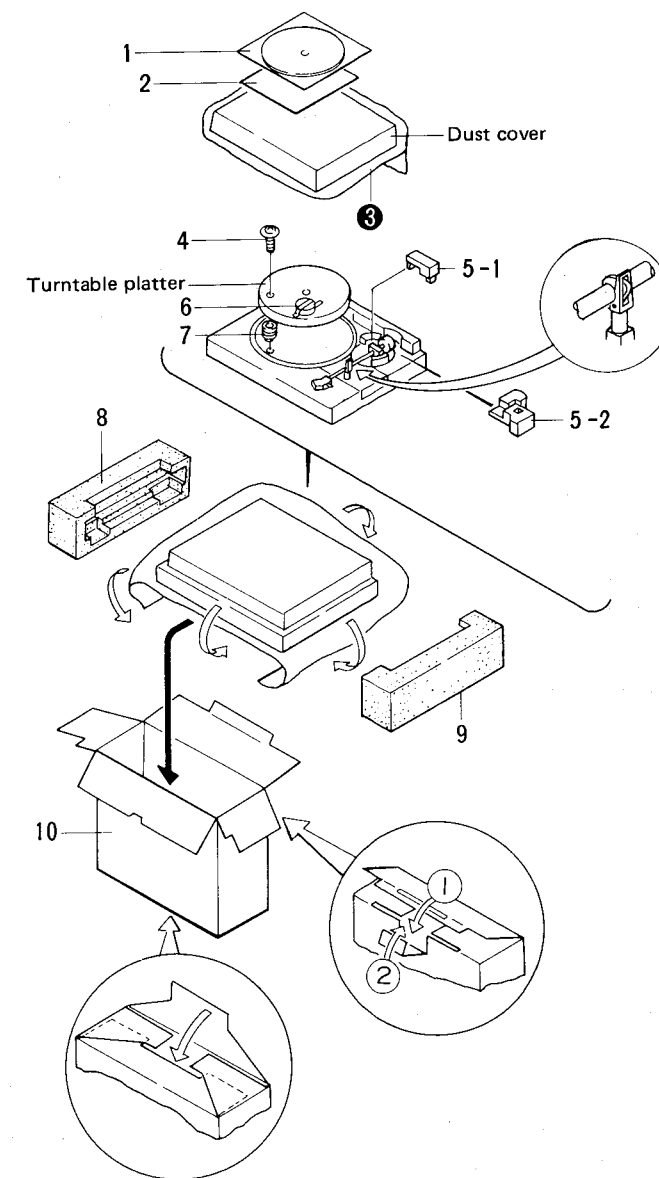

### Parts List of Packing

Mark	No.	Part No.	Description
	1.	PEA-067	Rubber mat assembly
	2.	PRB-258	Operating instructions (English) Sheet
	3.		Sheet
	4.	PBA-144	Clamp screw
	5-1	PHA-161	Weight clamp (A)
	5-2	PHA-162	Weight clamp (B)
	6.	N93-603	45 adaptor
	7.	PNX-294	Turntable protector
	8.	PHA-173	Side protector (L)
	9.	PHA-174	Side protector (R)
	10.	PHH-126	Packing case

# 7. P.C. BOARDS CONNECTION DIAGRAM

A  
B  
C  
D

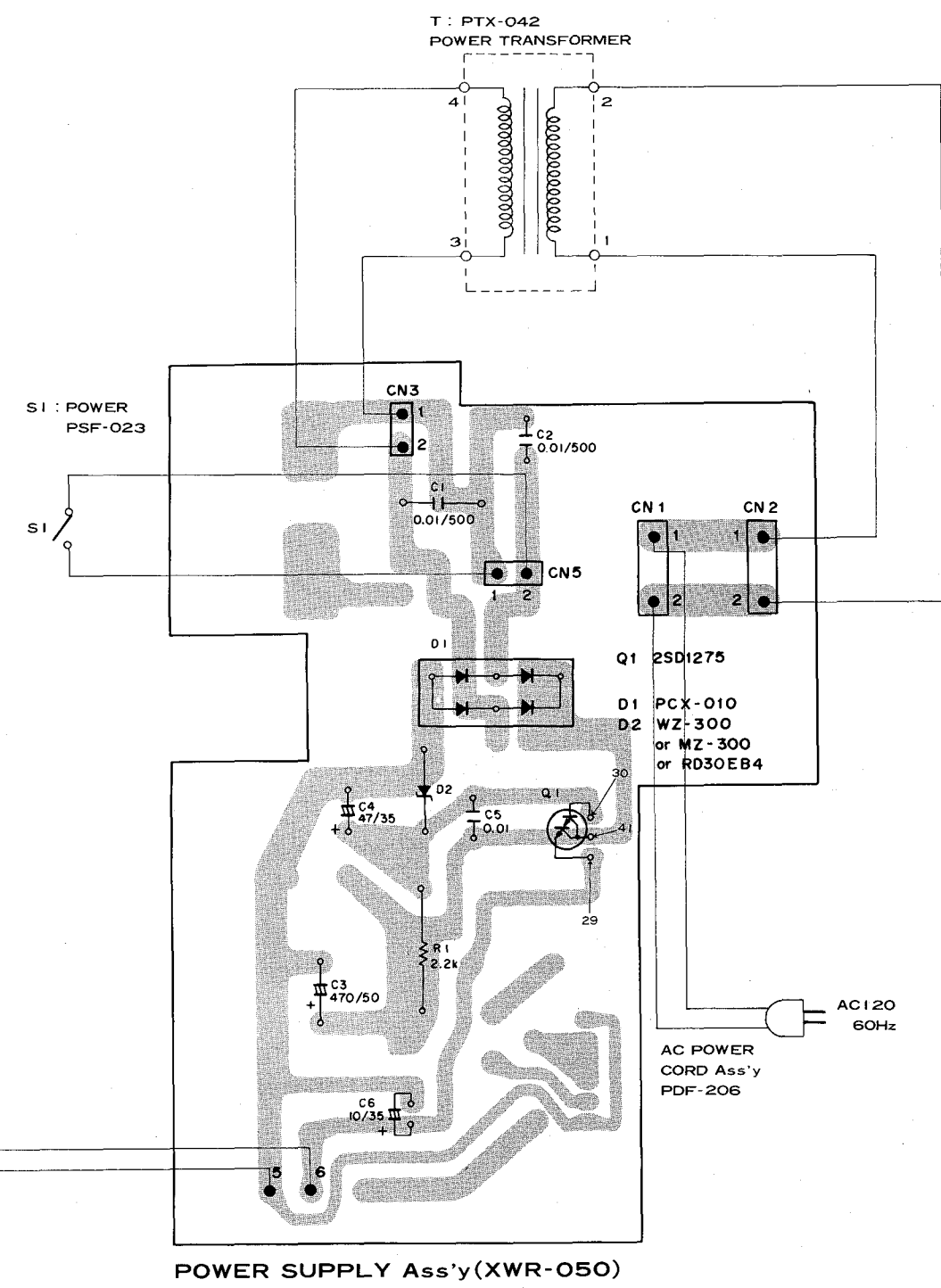
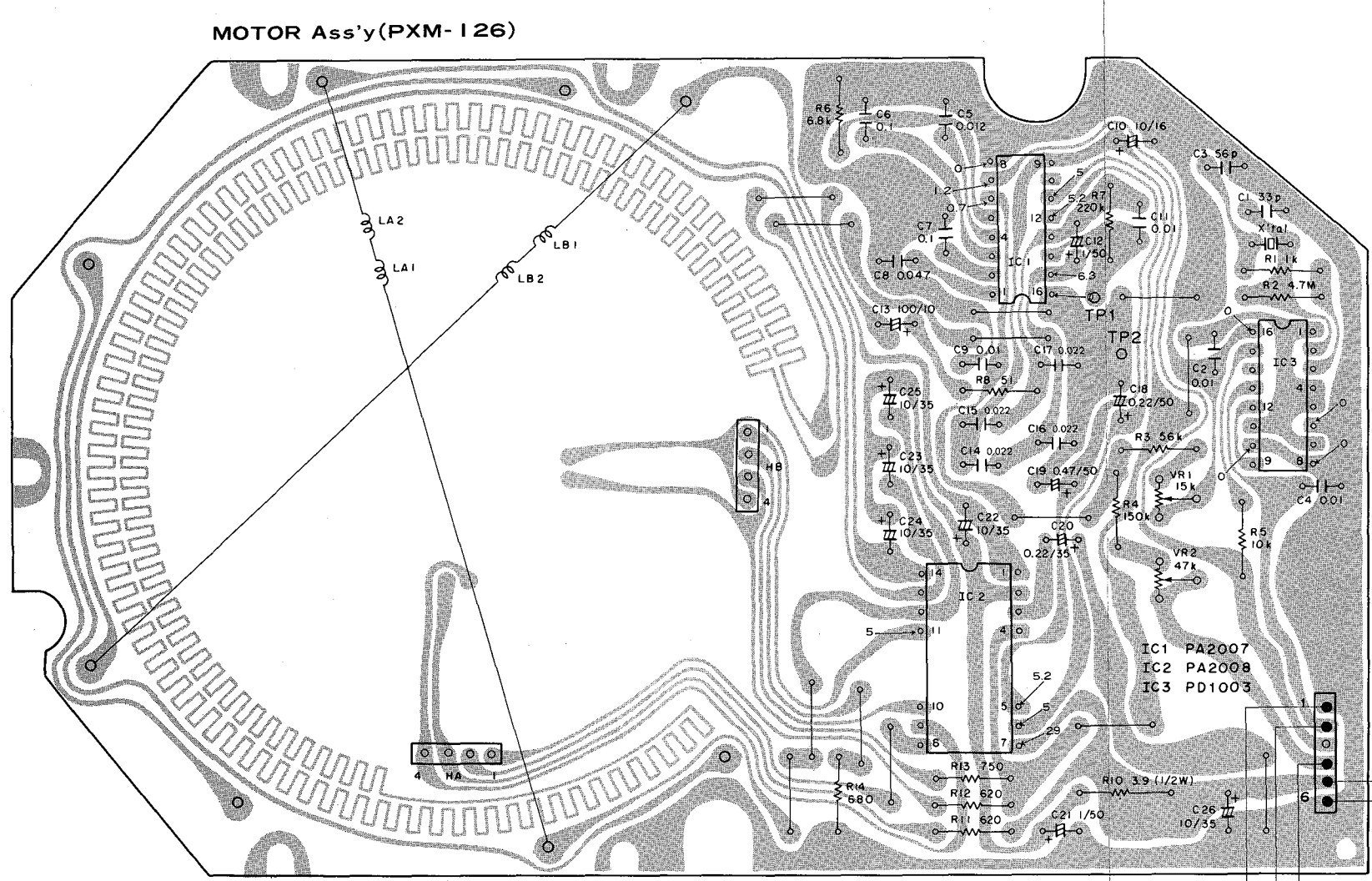

POWER SUPPLY Ass'y (XWR-050)

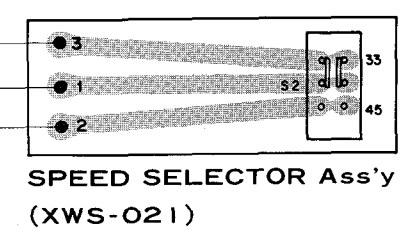

# 8. SCHEMATIC DIAGRAM

**NOTE:**  
The indicated semiconductors are representative ones only. Other alternative semiconductors may be used and are listed in the parts list.

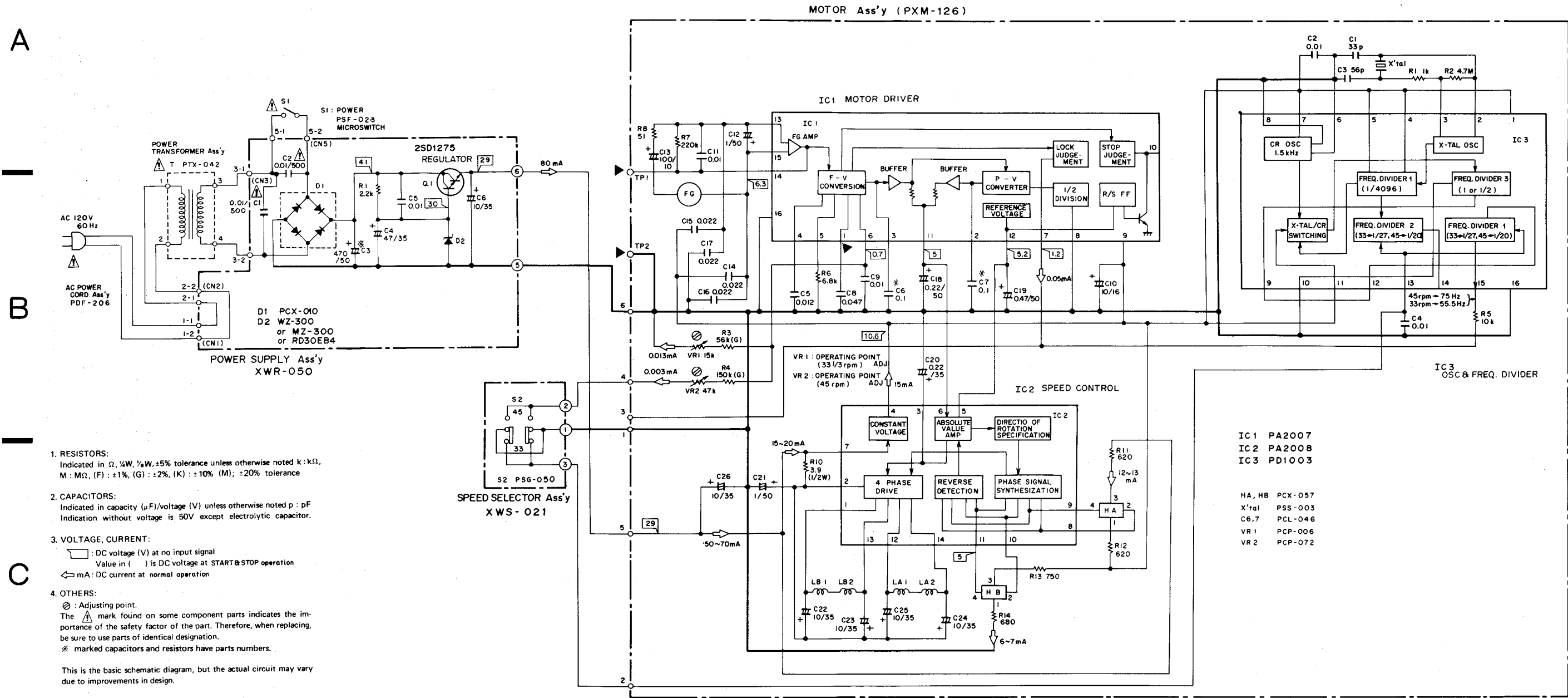

- RESISTORS:** Indicated in Ω, ¼W, ½W, ±5% tolerance unless otherwise noted k: kΩ, M: MΩ, (F): ±1%, (G): ±2%, (K): ±10% (M): ±20% tolerance
- CAPACITORS:** Indicated in capacity (μF)/voltage (V) unless otherwise noted p: pF. Indication without voltage is 50V except electrolytic capacitor.
- VOLTAGE, CURRENT:**
  - : DC voltage (V) at no input signal
  - Value in ( ) is DC voltage at START & STOP operation
  - ← mA: DC current at normal operation
- OTHERS:**
  - ⊗: Adjusting point.
  - The Δ mark found on some component parts indicates the importance of the safety factor of the part. Therefore, when replacing, be sure to use parts of identical designation.
  - \* marked capacitors and resistors have parts numbers.

This is the basic schematic diagram, but the actual circuit may vary due to improvements in design.

**SWITCHES:**

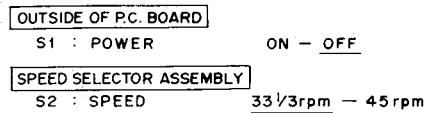

- IC 1 PA2007
- IC 2 PA2008
- IC 3 PD1003
- HA, HB PCX-057
- X'tal PSS-003
- C6,7 PCL-046
- VR 1 PCP-006
- VR 2 PCP-072

**External Appearance of Transistors and ICs**

2SD1275

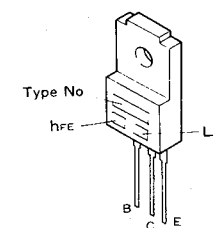

PA2007 PD1003

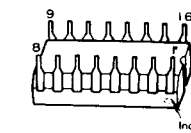

PA2008

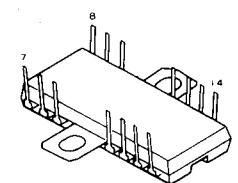

## 9. BLOCK DIAGRAM

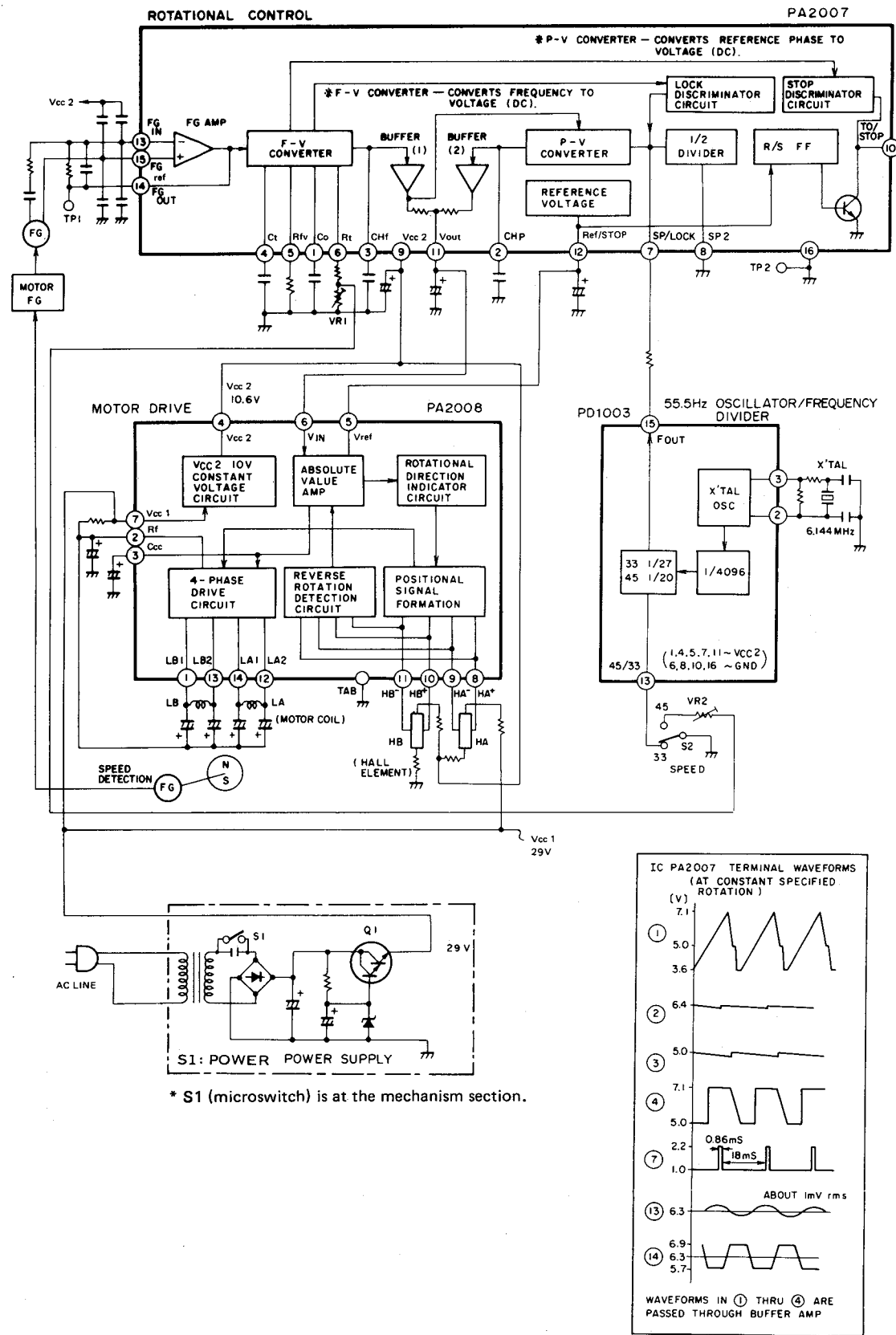

\* S1 (microswitch) is at the mechanism section.

## 10. CIRCUIT DESCRIPTIONS

### Quartz PLL Hall Motor (PXM-126)

This player uses a quartz PLL Hall motor (slotless) which uses a PA2007 for speed control, PA2008 for motor drive, and a PD1003 IC for oscillation and division.

#### Motor (Turntable) Rotation

Refer to the block diagram when reading the following description.

#### Drive circuit

- When the tone arm is moved toward the turntable, microswitch S1 (POWER switch) inside the mechanism section is turned on.
- When S1 is turned on, 29V is applied to pin ⑦ of motor drive IC PA2008 (IC2) and the Hall element.
- Since the PXM-126 is a slotless motor, the rotor (magnet) and drive coil positions are detected by two Hall elements, the current flowing in the drive coil is switched electronically, and the motor is rotated. When a voltage is applied to Hall elements HA and HB, a plus voltage (HA+) and a minus voltage (HA-) are generated by the magnetic field of the adjacent rotor. (Hall elements HA and HB are installed at positions at which their phases are electrically 90° apart.)
- This voltage is applied to the position signal combination circuit of PA2008, and the waveform is shaped as shown in Fig. 10-1 (a). The signals are further combined to produce a staircase signal such as that shown in Fig. 10-1 (b).
- This staircase signal is input to a four-phase drive circuit and the current flowing in drive coils LA and LB is switched alternately. Since this generates a magnetic field in the drive coils, the attraction or repulsion of the coil pole and rotor pole causes the motor to begin to rotate.

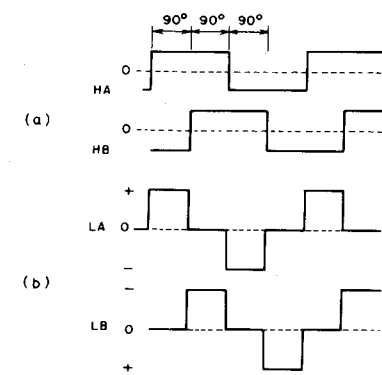

Fig. 10-1 Drive circuit waveforms

#### Constant Speed

#### Comparison control section

- When the motor starts to rotate, the signal from the frequency generator (FG) at the motor rotating section is shaped into a 50% duty square wave by the waveform shaping block and is applied to pin ⑮ (RG ref) and pin ⑬ (FG IN) of PA2007. The frequencies obtained here are 55.55 Hz for 33 rpm and 75 Hz for 45 rpm.
- This signal is amplified by the FG Amp of PA2007, converted to a voltage by the F-V converter, and applied to buffer amp 1.
- On the other hand, the 6.144 MHz signal of the crystal oscillator installed outside the oscillation and division IC PD1003 is divided to 1/4096 by the division circuit of PD1003. This signal is converted to phase comparison sampling pulses by a division ratio selection circuit. At 45 rpm, the signal is divided to 1/20 (75 Hz) and for 33 rpm, the signal is divided to 1/27 (55.5 Hz), and applied to pin ⑦ of PA2007.
- The sampling pulses from the PD1003 and the phase of the frequency corresponding to the motor speed are compared by the P-V converter of PA2007 and the voltage corresponding to the phase difference is applied to buffer amp 2.
- The buffer amp 1 and 2 outputs are combined and the output (pin ⑩) for comparison with the reference voltage is sent to pin ⑥ of the absolute value amp of PA2008.

#### Absolute value amp and rotating direction command circuit

- At absolute value amp PA2008, the input signal is compared with the reference voltage (Vref) from pin ⑫ of PA2007 and the motor winding current is generated according to the voltage difference.
- Since the speed does not reach the rated speed when the motor is started, the voltage is lower than the reference voltage (Vref; 5.15V). Therefore, the absolute value amp gives a command which generates a positive torque to the rotating direction command circuit so the motor speed is raised. Then the motor gradually reaches constant speed. (See Fig. 10-2.) (When the motor speed is faster than the rated speed, since the voltage is higher than the reference voltage, the absolute value amp applies reverse braking torque to the rotating direction command circuit so the motor speed drops. Then the speed returns to the rated speed.)

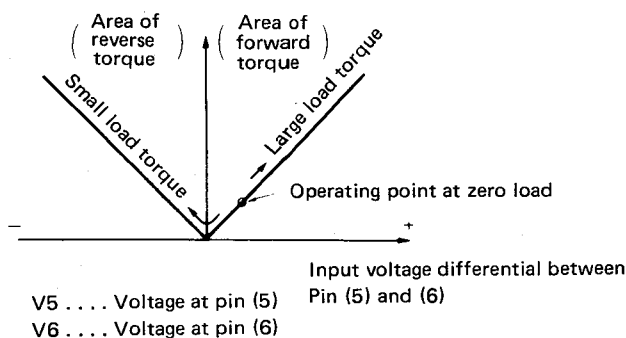

Fig.10-2 PA2008 absolute value amp input/output response.

## 11. ADJUSTMENTS

### 11.1 CONTROL MECHANISM ADJUSTMENT

#### ● Auto-Return Position Adjustment

When auto-return occurs too early or too late, make the following adjustments.

1. Check the stylus landing position. If the stylus does not land at the correct position, adjust the landing position.
2. Set the arm elevation switch to UP and turn the auto-return adjustment screw fully counterclockwise.
3. Move the tone arm as far as it will go toward the inside.
4. When the auto-return adjustment screws is turned slowly clockwise, the tone arm will begin to move toward the inside.
5. Stop turning the adjustment screw at the point at which there is a space of 32 mm between the cartridge stylus and the center shaft. (Fig. 11-1)
6. After adjustment, check that auto-return is performed correctly and that the stylus landing position is correct.

#### ● Arm Elevation Height Adjustment

1. Depress the arm elevation switch to lower the arm.
2. Adjust the screw under the turntable so the stylus is 11 mm above the panel. When the adjustment screw is turned counterclockwise, the stylus rises.
3. Depress the arm elevation switch to raise the tone arm.
4. Adjust the screws next to the arm elevation switch so the stylus is 25.5 mm above the panel.

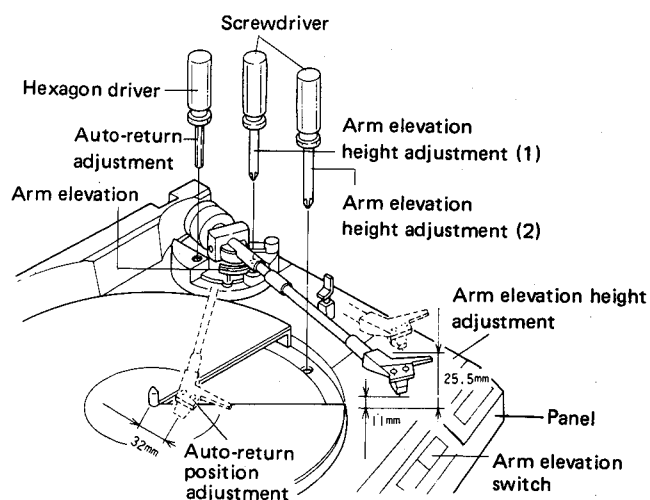

Fig. 11-1 Arm elevation height adjustment and auto-return adjustment

### 11.2 MOTOR OPERATING POINT ADJUSTMENT

Place the record player on blocks as shown in Fig. 11-2 and adjust the motor from the under base side.

1. Press the arm elevation switch and raise the tone arm.
2. The tone arm moves to the turntable side and the turntable rotates.
3. Set the turntable to 33 1/3 rpm.
4. Connect the buffer amplifier to pin ① of IC1 PA2007 of the motor circuit P. C. board unit as shown in Fig. 11-3 and connect the output to an oscilloscope.
5. After the waveform shown in Fig. 11-4 appears on the oscilloscope, adjust the oscilloscope gain so the peak of the sawtooth waveform is at division 5. Then adjust VR1 (33 1/3 rpm) to a:b = 2.7:2.3 as shown in Fig. 11-4. (Be careful because noise enters easily.)
6. At the end of 33 1/3 rpm adjustment, adjust 45 rpm with VR2 as described in 2 and 3 above. Always adjust 33 1/3 rpm first. Always adjust 45 rpm even if only 33 1/3 rpm is incorrectly adjusted.
7. Connect an oscilloscope to pin ⑦ of PA2007 and check that the waveform is 55.5 Hz for 33 1/3 rpm and 75 Hz for 45 rpm.

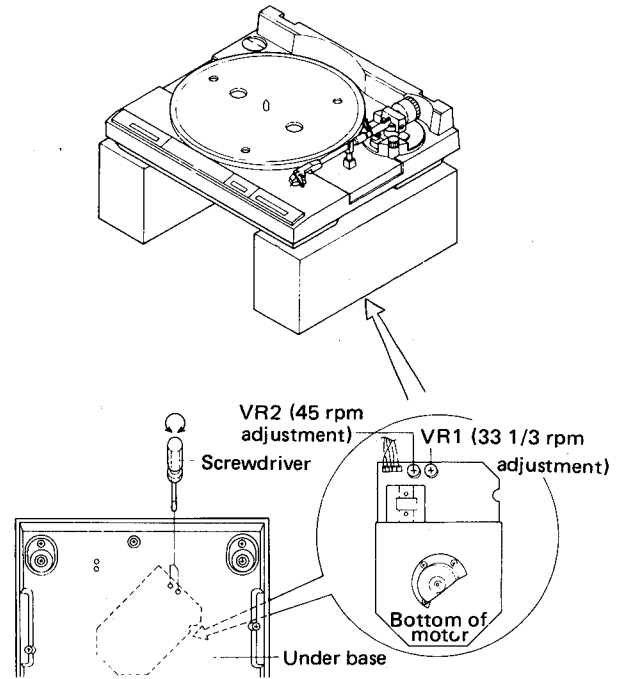

Fig. 11-2 Motor rotation adjustment

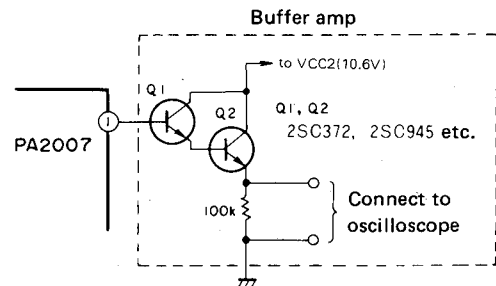

Fig. 11-3 Buffer amp connection

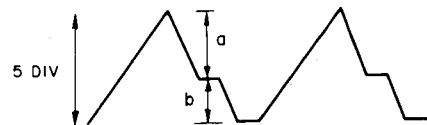

Fig. 11-4 Sawtooth wave adjustment

# 11. RÉGLAGES

## 11.1 RÉGLAGE DU MÉCANISME DE CONTRÔLE

### • Réglage de la position de retour automatique

Réaliser les réglages suivants lorsque le retour automatique se produit tôt ou trop tard.

1. Contrôler la position de descente de la pointe de lecture. Si la pointe de lecture ne descend pas sur la position correcte, ajuster la position de descente.
2. Régler la touche de relevage du bras sur la position "UP" et tourner la vis de réglage du retour automatique à fond dans le sens contraire des aiguilles d'une montre.
3. Déplacer le bras de lecture le plus possible vers l'intérieur.
4. Lorsque la vis de réglage du retour automatique est tournée lentement dans le sens des aiguilles d'une montre, le bras de lecture commence à se déplacer vers l'intérieur.
5. Arrêter de tourner la vis de réglage sur le point pour lequel il y a un écart de 32mm entre la pointe de lecture et l'axe central. (Fig. 11-1)
6. Après le réglage, vérifier que le retour automatique se réalise correctement et que la position de descente de la pointe est correcte.

### • Réglage de la hauteur de relevage du bras de lecture

1. Appuyer sur la touche de relevage du bras pour abaisser le bras.
2. Régler la vis située sous le tourne-disque de façon à ce que la pointe de lecture se situe à 11mm au-dessus du panneau. La pointe de lecture se soulève lorsque la vis de réglage est tournée dans le sens contraire des aiguilles d'une montre.
3. Appuyer sur la touche de relevage du bras pour soulever le bras de lecture.
4. Régler les vis situées à côté de la touche de relevage du bras, de façon à ce que la pointe de lecture se situe à 25,5mm au-dessus du panneau.

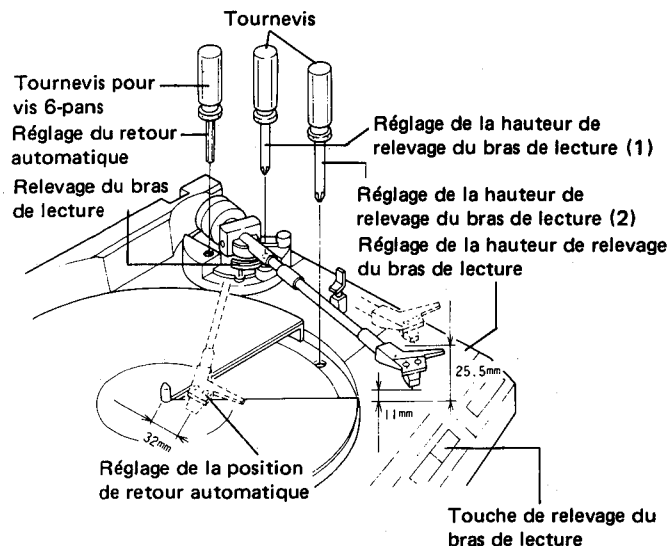

Fig. 11-1 Réglage de la hauteur de relevage du bras de lecture et de la position de retour automatique

### 11.2 RÉGLAGE DU POINT DE FONCTIONNEMENT DU MOTEUR

Placer le tourne-disque sur des plots, de la manière indiquée à la Fig. 11-2, et régler le moteur depuis le dessous du socle.

1. Presser le bouton de levage du bras pour le soulever.
2. Une fois le bras déplacé vers le côté du tourne-disques, il commence à tourner.
3. Régler le tourne-disques sur 33-1/3 tr/min.
4. Raccorder l'amplificateur tampon à la broche ① de IC1 PA2007 sur la carte de circuit imprimé du circuit moteur, comme indiqué à la Fig. 11-3, et raccorder la sortie à un oscilloscope.
5. Lorsque la forme d'onde indiquée à la Fig. 11-4 apparaît sur l'oscilloscope, régler le gain de l'oscilloscope de façon à ce que le sommet de l'onde en dent de scie se situe sur la division 5. Ajuster ensuite VR1 (33-1/3 tr/min) pour a:b = 2,7:2,3, comme indiqué à la Fig. 11-4. (Faire attention car les parasites s'introduisent facilement.)
6. En fin de réglage pour 33-1/3 tr/min, régler VR2 pour 45 tr/min, comme indiqué dans 2 et 3 ci-dessus. Le réglage pour 33-1/3 tr/min doit toujours être effectué en premier.  
Le réglage de 45 tr/min doit toujours être réalisé, même si seul 33-1/3 tr/min est mal réglé.
7. Raccorder un oscilloscope à la broche ⑦ de PA2007 et vérifier que la fréquence de la forme d'onde soit de 55,5Hz pour 45 tr/min.

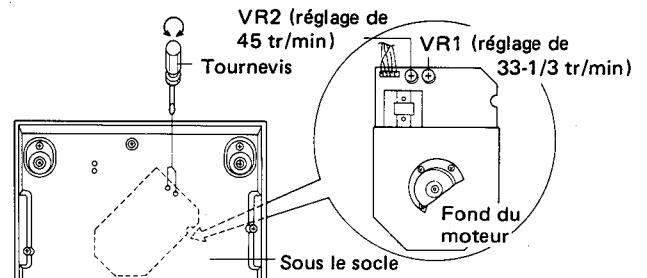
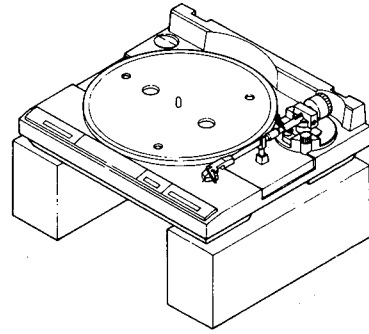

Fig. 11-2 Réglage de la vitesse de rotation du moteur

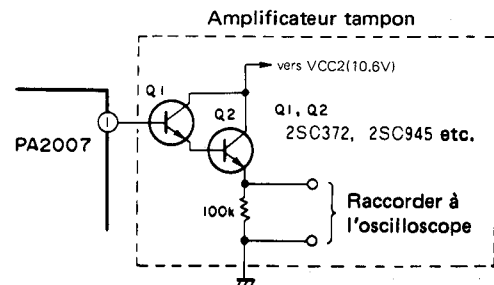

Fig. 11-3 Raccordement de l'amplificateur tampon

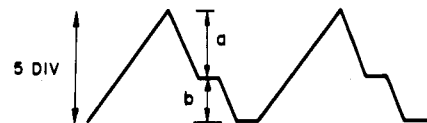

Fig. 11-4 Réglage de l'onde en dent de scie



## 11. AJUSTES

### 11.1 AJUSTE DEL MECANISMO DE CONTROL

#### • Ajuste de la posición de retorno automático

Cuando el retorno automático se produce demasiado rápido o demasiado tarde, efectuar los ajustes siguientes.

1. Comprobar la posición de descenso de la aguja. Si la aguja no desciende en la posición correcta, ajustar la posición de descenso.
2. Ajustar el interruptor de elevación del brazo en la posición UP y girar el tornillo de ajuste de retorno automático completamente hacia la izquierda.
3. Desplazar el brazo fonocaptor hacia el interior al máximo.
4. Cuando se giran lentamente los tornillos de ajuste de retorno automático hacia la derecha, el brazo fonocaptor empezará a moverse hacia el interior.
5. Dejar de girar el tornillo de ajuste en el punto en el que haya un espacio de 32mm entre la aguja de la cápsula y el eje central. (Fig. 11-1)
6. Después del ajuste, comprobar que la operación de retorno automático se efectúe correctamente y que la posición de descenso de la aguja sea la correcta.

#### • Ajuste de la altura de la elevación del brazo

1. Presionar el interruptor de elevación del brazo para hacerlo descender.
2. Ajustar el tornillo de debajo del giradiscos de modo que la aguja esté 11mm por encima del panel. Cuando el tornillo de ajuste se gira hacia la izquierda, se eleva la aguja.
3. Presionar el interruptor de elevación del brazo para que se eleve el brazo fonocaptor.
4. Ajustar los tornillos situados al lado del interruptor de elevación del brazo de modo que la aguja quede 25,5mm por encima del panel.

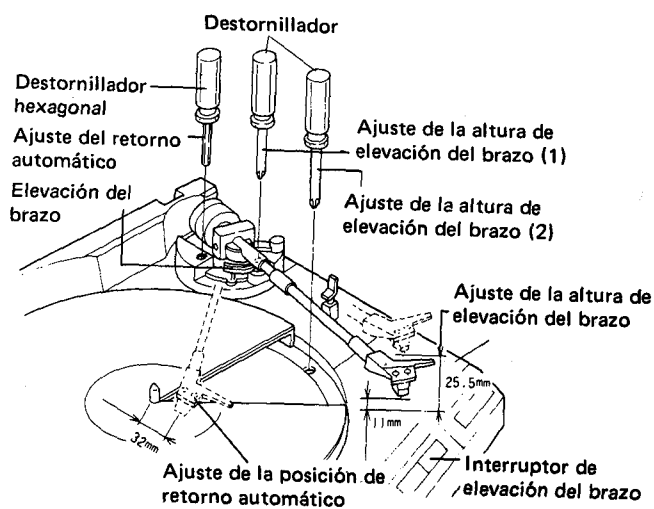

Fig. 11-1 Ajuste de la altura de elevación del brazo y ajuste del retorno automático

### 11.2 AJUSTE DEL PUNTO DE OPERACION DEL MOTOR

Poner el tocadiscos sobre bloques como se muestra en la Fig. 11-2 y ajustar el motor desde debajo de la base.

1. Presionar el interruptor de elevación del brazo para hacerlo elevar.
2. El brazo fonocaptor se mueve hacia el plato y éste empieza a girar.
3. Ajustar el giradiscos a 33-1/3 rpm.
4. Conectar el amplificador intermedio a la patilla ① del IC1PA2007 del PCB del circuito del motor como se muestra en la Fig. 11-3 y conectar la salida a un osciloscopio.
5. Una vez aparece la forma de onda mostrada en la Fig. 11-4 en el osciloscopio, ajustar la ganancia del osciloscopio de modo que el pico de la forma de onda de diente de sierra está en la división 5. Luego, ajustar VR1 (33-1/3 rpm) a  $a:b = 2,7:2,3$  como se muestra en la Fig. 11-4. (Tener cuidado porque el ruido se introduce con facilidad.)
6. Al finalizar el ajuste de 33-1/3 rpm, ajustar las 45 rpm con VR2 como se ha descrito en los pasos 2 y 3 de arriba. Ajustar siempre primero las 33-1/3 rpm.  
Ajustar siempre las 45 rpm aunque sólo 33-1/3 rpm estén incorrectamente ajustadas.
7. Conectar un osciloscopio a la patilla ⑦ de PA2007 y comprobar que la forma de onda sea de 55,5Hz para 33-1/3 rpm y 75Hz para 45 rpm.

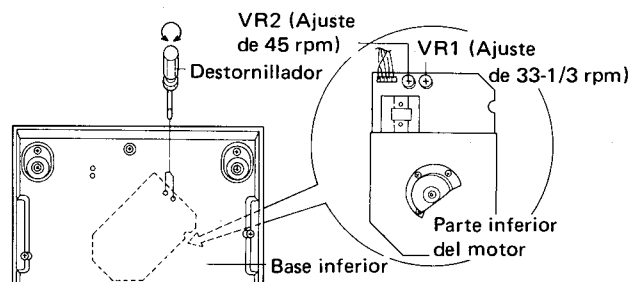
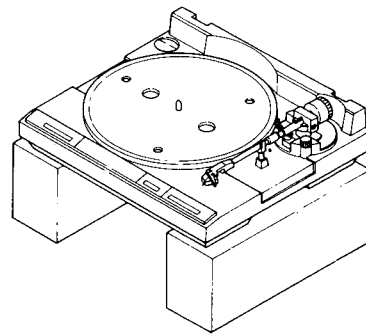

Fig. 11-2 Ajuste de la rotación del motor

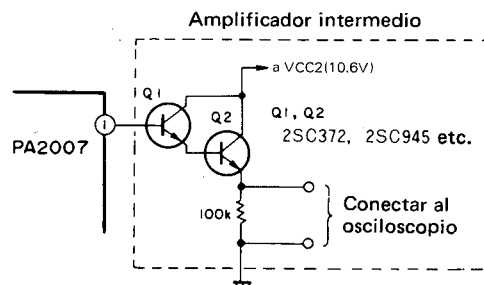

Fig. 11-3 Conexión del amplificador intermedio

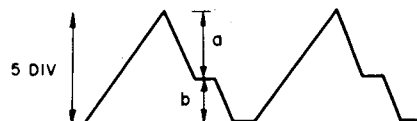

Fig. 11-4 Ajuste de la onda de diente de sierra

## 12. PRECAUTIONS FOR REASSEMBLY

Follow these directions and precautions when reassembling a unit after completing repairs. Be sure to lubricate as required, make no mistakes when attaching parts, and avoid all other careless mistakes that may be the cause of trouble later on.

### 12.1 AREAS THAT REQUIRE LUBRICATION

**NOTE:**

Types of lubricants and areas where they are used are listed in table 1.

Table 1

Type of Oil	Areas used
Silicon Oil #50000	raising shaft
GYA-008	all other areas

Lubrication points are specified for oils other than GYA-008. Never use a different type of oil.

● **Cam Section**

Apply grease to the heart-shaped grooved section (rear side of the cam) and lock plate sliding section in order to minimize wear on the sliding section and the burden on the mechanism.

● **Driving Plate Assembly**

Decrease the burden on the mechanism and the wear on the sliding section.

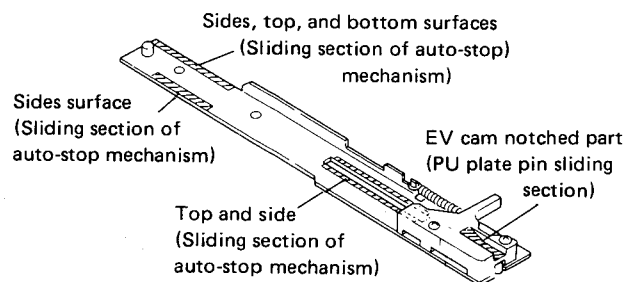

Fig. 12-1 Driving panel assembly section Switch Locker Section

● **Switch Locker Section**

Apply grease to the switch locker (opening) and sub-panel base sliding section to decrease the burden on the mechanism.

When applying grease to the opening (shaft hole), do not apply any grease 2 ~ 3mm from the bottom surface. If grease is applied 2 ~ 3mm within the bottom surface, it may come out the bottom and go between the switch lever and sub-panel base causing the switch lever to operate ineffectively.

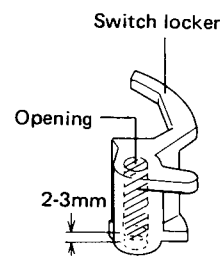
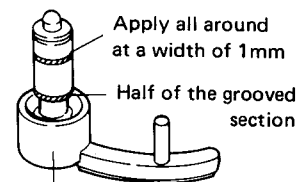

Fig. 12-2 Switch locker section

● **EV Sheet Section**

Apply oil to the raising shaft and sliding section of the bearing to assure stability in the elevation lowering speed.



EV sheet assembly

Fig. 12-3 EV sheet section

● **EV Lever Section**

Coat the EV lever shaft section with grease so the EV lever operates smoothly.

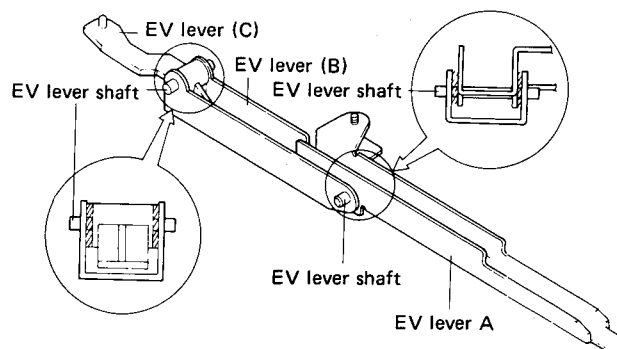

Fig. 12-4 EV lever section

● **Cut Rod Section**

Coat the cut rod support section with grease so it operates smoothly.

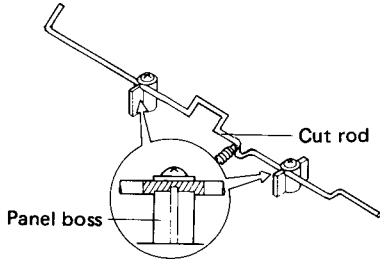

Fig. 12-5 Cut rod section

**12.2 PRECAUTIONS FOR ATTACHMENT OF PARTS AND REASSEMBLY**

● **Reset Plate SP Attachment**

As shown in Fig. 12-6, the reset plate SP hook is attached by putting the open section on the sub-panel base side.

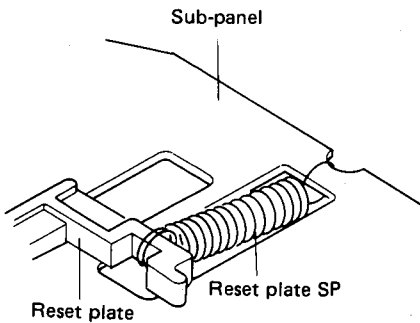

Fig. 12-6 Reset plate SP attachment

● **Cam Assembly Attachment**

The cam assembly is attached by letting the lock plate go in the direction **A** as shown in Fig. 12-7.

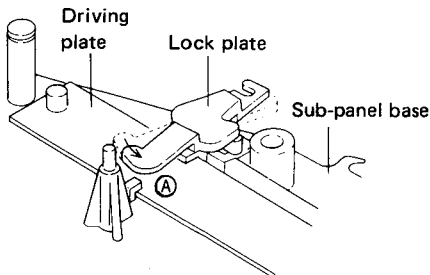

Fig. 12-7 Cam assembly attachment

● **Arm Base Attachment**

When attaching the arm base section to the mechanism section, put the mechanism section switch locker and switch lever in the locked position and verify that the tonearm is in the arm rest location. Also be sure to put the manual elevation lever in the up position and check that the PU plate shaft is in the position shown in Fig. 12-8.

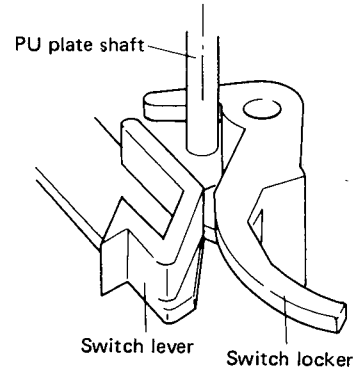

Fig. 12-8 Arm base attachment

● **PU Plate Ass'y Attachment**

The PU plate ass'y is attached by pushing the PU plate bearing section against the arm rotating shaft fixing nut.

The attachment direction is matched to the center of the support line as shown in Fig. 12-9 (tone arm position on the arm rest).

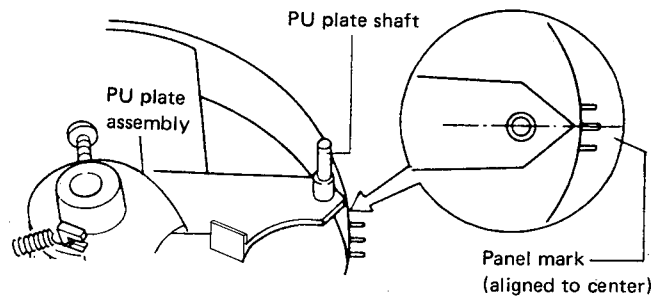

Fig. 12-9 PU plate attachment

- EV Lever Pushbutton Switch Attachment**  
 When attaching the pushbutton switch to the EV lever, insert it at the groove at the bottom of the shaft as shown in Fig. 12-10. If it is inserted at the groove at the top of the shaft, arm elevation will not operate.

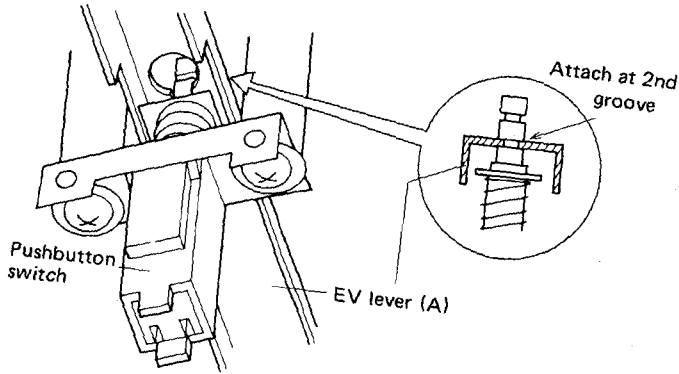

Fig. 12-10 EV lever pushbutton switch attachment

- Motor Attachment**  
 When installing the motor, set the cam in the mechanism stop location and verify that the starting plate section (B) does not protrude beyond surface (A) of the cam. If the motor is attached with the starting plate section (B) protruding, the starting plate may be deformed, the motor pinion gear may be scratched, and the return function may be damaged.

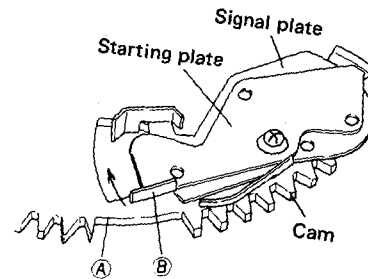

Fig. 12-12 Motor attachment

- PU lead wire position confirmation**  
 When attaching the mechanism ass'y to the panel, be careful that the PU lead wire is not pinched at the panel boss as shown in Fig. 12-11.

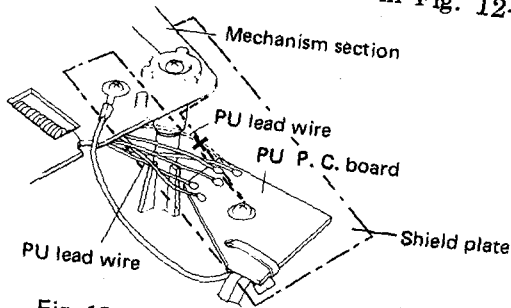

Fig. 12-11 PU lead wire attachment

- Installing the cords**  
 When installing the PU lead wire and AC power cord, install them to the panel with string as shown in Fig. 12-13.

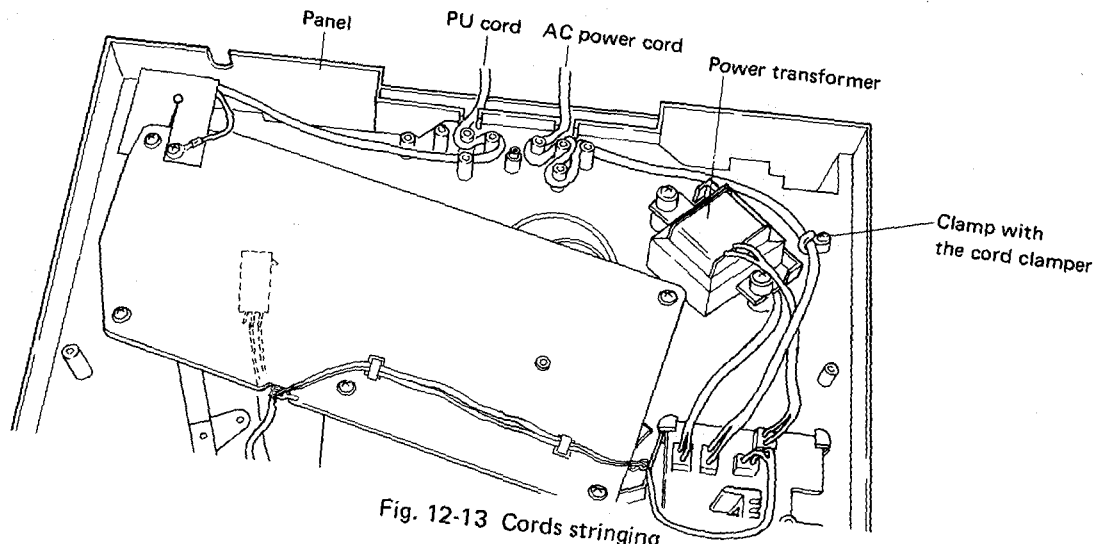

Fig. 12-13 Cords stringing

## 13. FOR PL-750/KC, R, WEM AND WP TYPES

### 13.1 CONTRAST PARTS

PL-750/KC, R, WEM and WP types are same as the PL-750/KU type except for following sections.

#### Miscellaneous Parts

Mark	Symbol & Description	Part No.				
		KU type	KC type	R type	WP type	WEM type
⚠	Panel	PNY-155	PNY-155	PNY-156	PNY-155	PNY-155
⚠	AC power cord assembly	PDF-206	PDF-206	PDF-147	PDF-205	PDF-209
⚠ ★	Power transformer (AC 120V)	PTX-042	PTX-043	...	...	...
⚠ ★	Power transformer (AC 110V ~ 120V, 220V ~ 240V)	...	...	PTX-045	...	...
⚠ ★	Power transformer (AC 220V ~ AC 240V)	...	...	...	PTX-044	PTX-044
⚠ ★★	Line voltage selector	...	...	PSB-011	...	...
	Screw 3 x 10 (For Line voltage selector)	...	...	IPZ30P100FMC	...	...
	PU cord assembly	PXB-345	PXB-333	PXB-333	PXB-333	PXB-333
	Packing case	PHH-126	PHH-127	PHH-128	PHH-128	PHH-128
	Operating instructions (Spanish)	...	...	PRC-007	...	...
	Operating instructions (English)	PRB-258	PRB-258	PRB-258	PRB-258	PRB-258
	Operating instructions (English/German/French/Italian)	...	...	...	...	PRE-025

### 13.2 SCHEMATIC DIAGRAM

For WP and WEM types

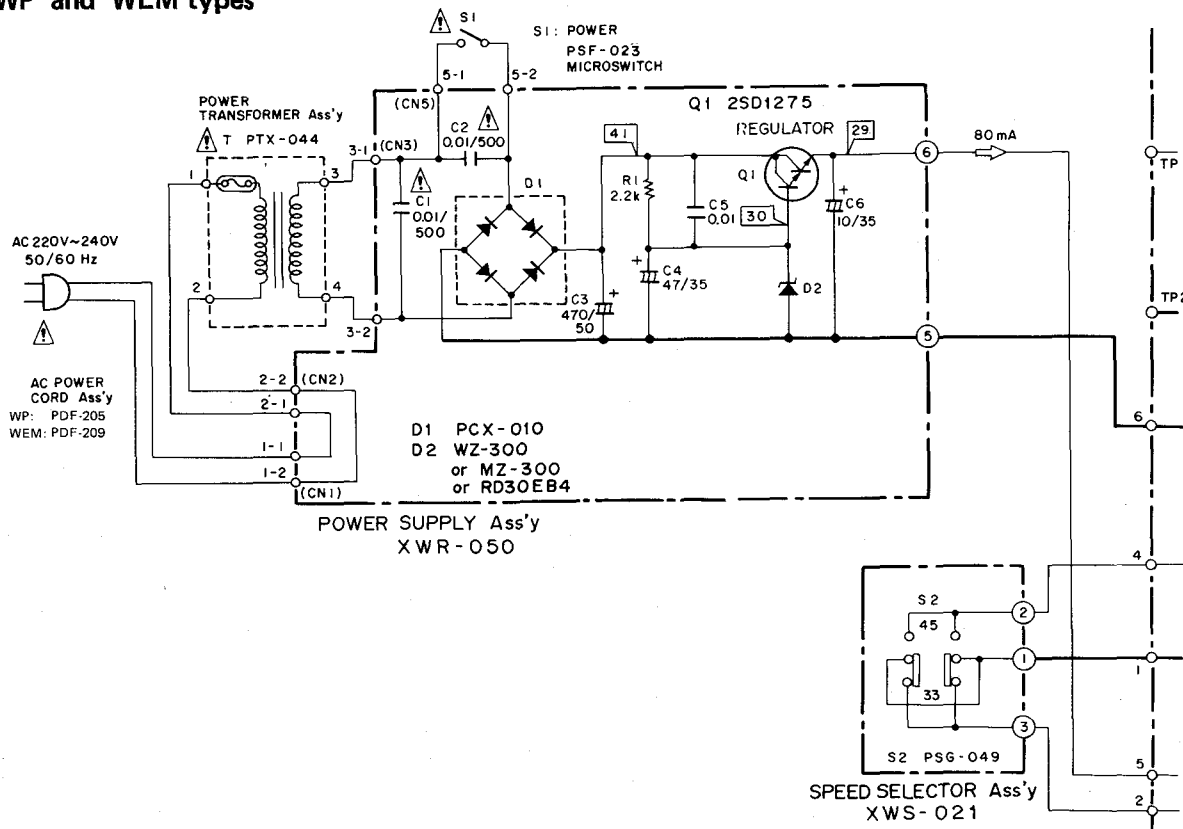

For KC type

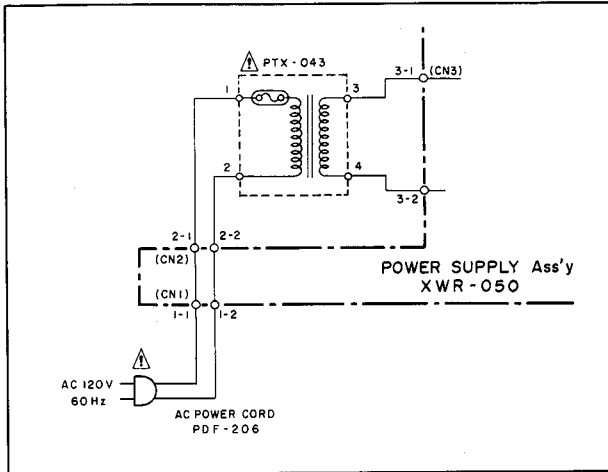

For R type

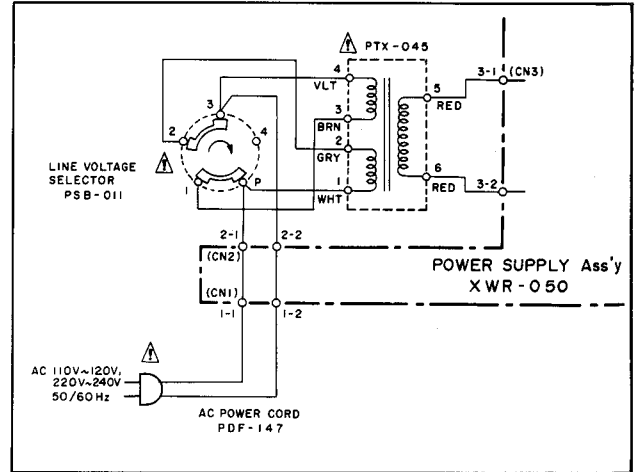

# 14. SAFETY INFORMATION

## 1. SAFETY PRECAUTIONS

The following check should be performed for the continued protection of the customer and service technician.

### LEAKAGE CURRENT CHECK

Measure leakage current to a known earth ground (water pipe, conduit, etc.) by connecting a leakage current tester such as Simpson Model 229-2 or equivalent between the earth ground and all exposed metal parts of the appliance (input/output terminals, screwheads, metal overlays, control shaft, etc.). Plug the AC line cord of the appliance directly into a 120V AC 60Hz outlet and turn the AC power switch on. Any current measured must not exceed 0.5mA.

ANY MEASUREMENTS NOT WITHIN THE LIMITS OUTLINED ABOVE ARE INDICATIVE OF A POTENTIAL SHOCK HAZARD AND MUST BE CORRECTED BEFORE RETURNING THE APPLIANCE TO THE CUSTOMER.

## 2. PRODUCT SAFETY NOTICE

Many electrical and mechanical parts in the appliance have special safety related characteristics. These are often not evident from visual inspection nor the protection afforded by them necessarily can be obtained by using replacement components rated for voltage, wattage, etc. Replacement parts which have these special safety characteristics are identified in this Service Manual.

Electrical components having such features are identified by marking with a ⚠ on the schematics and on the parts list in this Service Manual.

The use of a substitute replacement component which does not have the same safety characteristics as the PIONEER recommended replacement one, shown in the parts list in this Service Manual, may create shock, fire, or other hazards.

Product Safety is continuously under review and new instructions are issued from time to time. For the latest information, always consult the current PIONEER Service Manual. A subscription to, or additional copies of, PIONEER Service Manual may be obtained at a nominal charge from PIONEER.

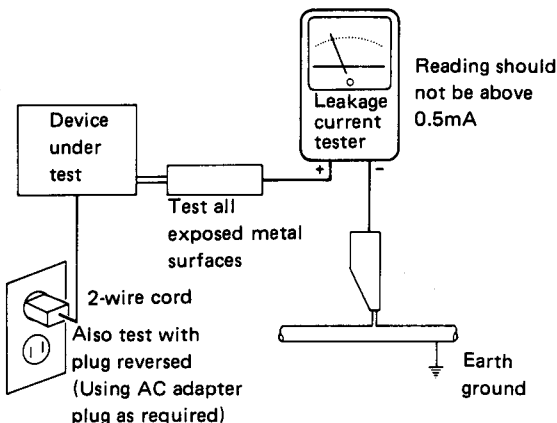

AC Leakage Test

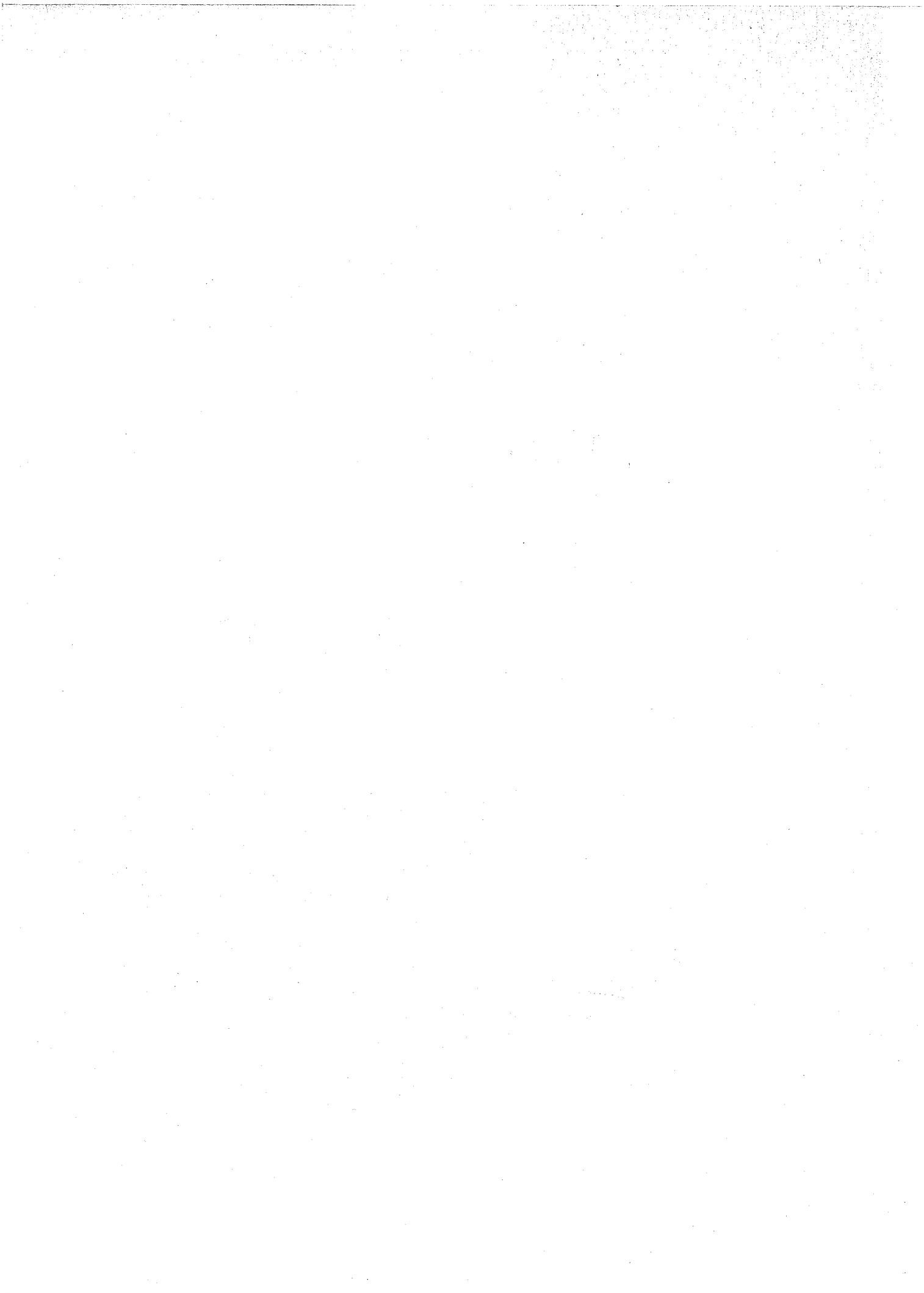



**QUESTIONNAIRE**

MODEL \_\_\_\_\_

One Model per questionnaire

Dear Servicer,

Thank you for your cooperation in the post-sale service of Pioneer products.

This questionnaire is used as a tool to improve the serviceability of our products and service manuals. Please evaluate this model and service manual by answering the following questions. Your ideas may be realized in our future products. Your answers will be appreciated. Thank you.

PIONEER ELECTRONIC CORP.

T. Nakagawa, Manager, Service Section, International Division

1. SERVICING EVALUATION	Circle applicable number:	Good	Fair	Poor		
a. Disassembly/Re-assembly:		1	2	3	*4	*5
b. Circuit Checks:		1	2	3	*4	*5
c. Replacement of Parts:		1	2	3	*4	*5
d. Adjustment (s):		1	2	3	*4	*5

\* If (4) or (5) was circled, please be specific.

e. Your advice, opinion or ideas related to servicing this product.

**2. SERVICE MANUAL EVALUATION**

a. Circuit & Mechanism Description

b. Circuit Diagram

**3. OTHER**

Please describe other areas of servicing which you may find difficult.

Completed by :

Date :

Company Name :

Address :

City/State/Zip :

Please send this form filled to the distributor in your country.

QUESTIONNAIRE

Modèle \_\_\_\_\_

Un modèle par questionnaire

Cher Monsieur,

Merci pour votre coopération à propos du service après-vente des produits PIONEER.

Ce questionnaire a pour but l'amélioration de notre service d'entretien et des manuels de nos produits. Nous vous prions d'évaluer dans ce questionnaire les éléments de nos manuels de service. Vos conseils seront précieux et pris en considération dans la réalisation de nos produits dans l'avenir.

En vous remerciant d'avance, agréez, cher monsieur, l'expression de nos sentiments distingués.

PIONEER ELECTRONIC CORPORATION

T. Nakagawa, Manager, Service Section, Administration Department, International Division

1. ÉVALUATION EN FACILITÉ DE SERVICE

Cerclez le numéro.

MODÈLE

Bon, Passable, Mauvais,

a. Démontage/remontage

1 2 3 \*4 \*5

b. Examen de circuits

1 2 3 \*4 \*5

c. Rechange de pièces

1 2 3 \*4 \*5

d. Facilité de réglage

1 2 3 \*4 \*5

\* Si vous cerclez No. 4 ou 5, donnez l'explication concrète.

e. Votre conseil ou avis sur le service

**2. VOTRE APPRÉCIATION DU MANUEL DE SERVICE**

a. Circuit et description du mécanisme.

b. Diagramme du circuit.

**3. AUTRES**

Anotez les autres points difficiles à réparer.

Répondu par :

Date :

Nom :

Âge :

Compagnie :

Adresse :

Adressez-vous ce questionnaire au distributeur, S.V.P.

**ENCUESTA**

Modelo \_\_\_\_\_

Uno modelo por encuesta

Querido señor,

Muchas gracias por su cooperación en el servicio de post-venta de los productos de Pioneer. Esto es para mejorar el servicio de post-venta de nuestros productos. Les pedimos a ustedes responder a las preguntas siguientes. Su opinión e idea estarán tenido en cuenta en los productos futuros.

Nos complacemos en saludarles muy atentamente,

**PIONEER ELECTRONIC CORPORATION**

T. Nakagawa, Manager, Service Section, Administration Department, International Division

**1. EVALUACION EN LA FACILIDAD DE SERVICIO**

**MODELO**

Marque uno entre los numeros siguientes.

Bueno      Medio      Malo

a. Desmante:

1      2      3      \*4      \*5

b. Examen de circuito:

1      2      3      \*4      \*5

c. Reemplazo de piezas:

1      2      3      \*4      \*5

d. Ajuste:

1      2      3      \*4      \*5

\* Si marca (4) o (5), ejemplifiquelo concretamente.

e. Su consejo, opinión u idea en el servicio de este modelo.

## 2. EVALUACION DEL MANUAL DE SERVICIO

a. Circuito & Descripción de mecanismos.

b. Diagrama del circuito.

## 3. OTRAS

Describe otras partes difíciles de reparar.

Respondido por :

Nombre :

Compañía :

Dirección :

Fecha :

Edad :

Manda esta encuesta al domicilio del distribuidor, por favor.

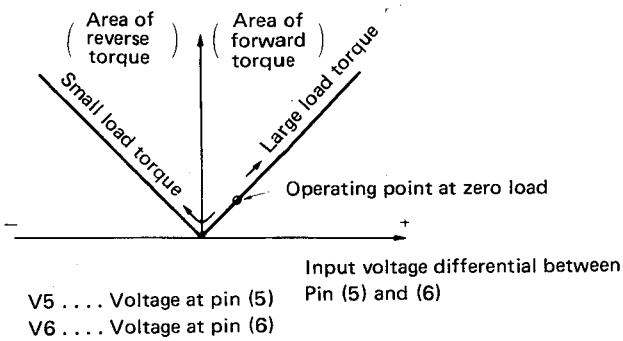

Fig.10-2 PA2008 absolute value amp input/output response.

# 11.ADJUSTMENTS

## 11.1 CONTROL MECHANISM ADJUSTMENT

### ● Auto-Return Position Adjustment

When auto-return occurs too early or too late, make the following adjustments.

1. Check the stylus landing position. If the stylus does not land at the correct position, adjust the landing position.
2. Set the arm elevation switch to UP and turn the auto-return adjustment screw fully counter-clockwise.
3. Move the tone arm as far as it will go toward the inside.
4. When the auto-return adjustment screws is turned slowly clockwise, the tone arm will begin to move toward the inside.
5. Stop turning the adjustment screw at the point at which there is a space of 32 mm between the cartridge stylus and the center shaft. (Fig. 11-1)
6. After adjustment, check that auto-return is performed correctly and that the stylus landing position is correct.

### ● Arm Elevation Height Adjustment

1. Depress the arm elevation switch to lower the arm.
2. Adjust the screw under the turntable so the stylus is 11 mm above the panel. When the adjustment screw is turned counterclockwise, the stylus rises.
3. Depress the arm elevation switch to raise the tone arm.
4. Adjust the screws next to the arm elevation switch so the stylus is 25.5 mm above the panel.

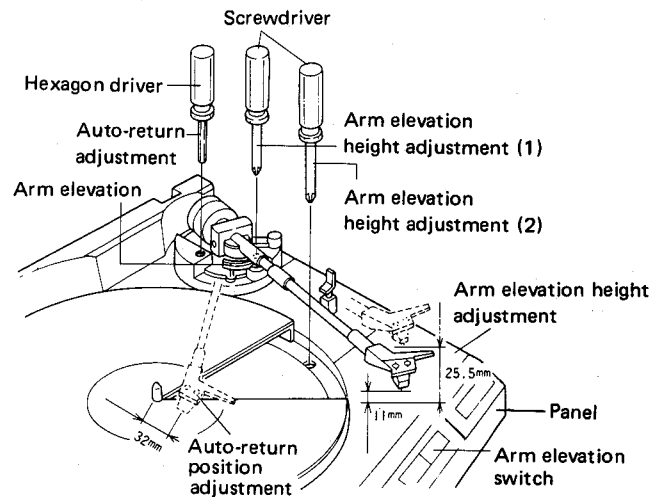

Fig. 11-1 Arm elevation height adjustment and auto-return adjustment

## 11.2 MOTOR OPERATING POINT ADJUSTMENT

Place the record player on blocks as shown in Fig. 11-2 and adjust the motor from the under base side.

1. Press the arm elevation switch and raise the tone arm.
2. The tone arm moves to the turntable side and the turntable rotates.
3. Set the turntable to 33 1/3 rpm.
4. Connect the buffer amplifier to pin ① of IC1 PA2007 of the motor circuit P. C. board unit as shown in Fig. 11-3 and connect the output to an oscilloscope.
5. After the waveform shown in Fig. 11-4 appears on the oscilloscope, adjust the oscilloscope gain so the peak of the sawtooth waveform is at division 5. Then adjust VR1 (33 1/3 rpm) to a:b = 2.7:2.3 as shown in Fig. 11-4. (Be careful because noise enters easily.)
6. At the end of 33 1/3 rpm adjustment, adjust 45 rpm with VR2 as described in 2 and 3 above. Always adjust 33 1/3 rpm first. Always adjust 45 rpm even if only 33 1/3 rpm is incorrectly adjusted.
7. Connect an oscilloscope to pin ⑦ of PA2007 and check that the waveform is 55.5 Hz for 33 1/3 rpm and 75 Hz for 45 rpm.

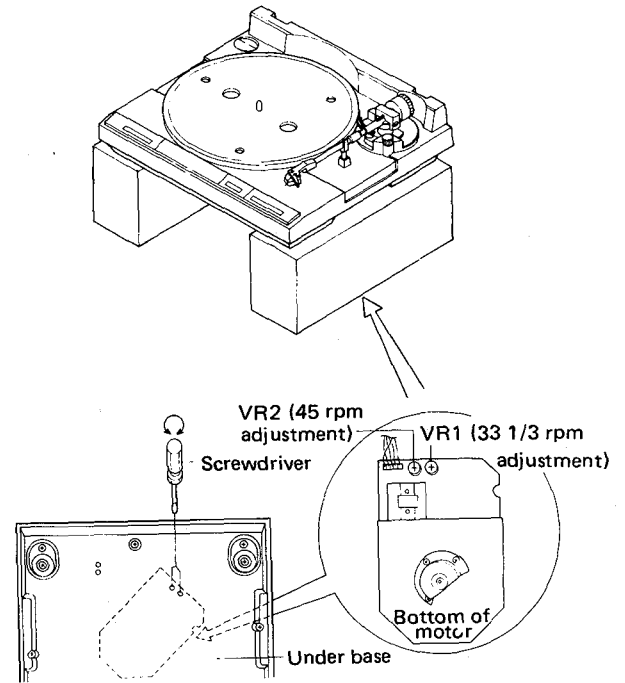

Fig. 11-2 Motor rotation adjustment

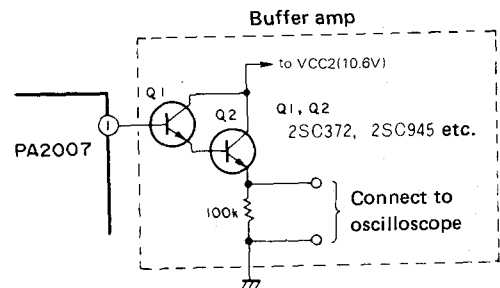

Fig. 11-3 Buffer amp connection

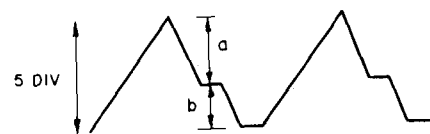

Fig. 11-4 Sawtooth wave adjustment



# 11. RÉGLAGES

## 11.1 RÉGLAGE DU MÉCANISME DE CONTRÔLE

### • Réglage de la position de retour automatique

Réaliser les réglages suivants lorsque le retour automatique se produit tôt ou trop tard.

1. Contrôler la position de descente de la pointe de lecture. Si la pointe de lecture ne descend pas sur la position correcte, ajuster la position de descente.
2. Régler la touche de relevage du bras sur la position "UP" et tourner la vis de réglage du retour automatique à fond dans le sens contraire des aiguilles d'une montre.
3. Déplacer le bras de lecture le plus possible vers l'intérieur.
4. Lorsque la vis de réglage du retour automatique est tournée lentement dans le sens des aiguilles d'une montre, le bras de lecture commence à se déplacer vers l'intérieur.
5. Arrêter de tourner la vis de réglage sur le point pour lequel il y a un écart de 32mm entre la pointe de lecture et l'axe central. (Fig. 11-1)
6. Après le réglage, vérifier que le retour automatique se réalise correctement et que la position de descente de la pointe est correcte.

### • Réglage de la hauteur de relevage du bras de lecture

1. Appuyer sur la touche de relevage du bras pour abaisser le bras.
2. Régler la vis située sous le tourne-disque de façon à ce que la pointe de lecture se situe à 11mm au-dessus du panneau. La pointe de lecture se soulève lorsque la vis de réglage est tournée dans le sens contraire des aiguilles d'une montre.
3. Appuyer sur la touche de relevage du bras pour soulever le bras de lecture.
4. Régler les vis situées à côté de la touche de relevage du bras, de façon à ce que la pointe de lecture se situe à 25,5mm au-dessus du panneau.

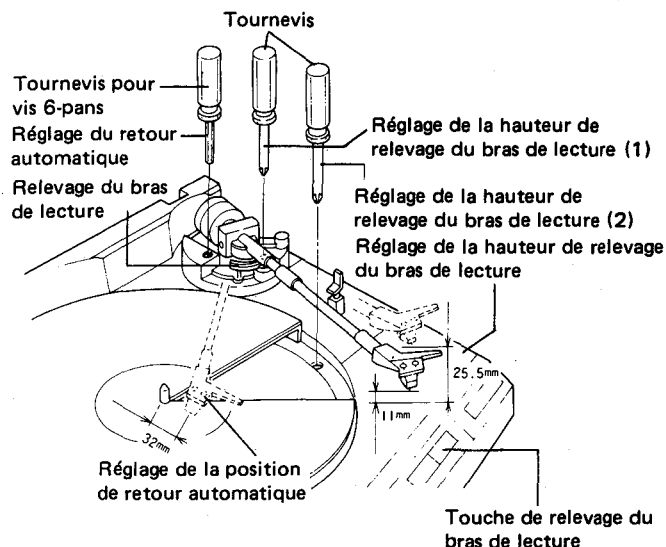

Fig. 11-1 Réglage de la hauteur de relevage du bras de lecture et de la position de retour automatique

### 11.2 RÉGLAGE DU POINT DE FONCTIONNEMENT DU MOTEUR

Placer le tourne-disque sur des plots, de la manière indiquée à la Fig. 11-2, et régler le moteur depuis le dessous du socle.

1. Presser le bouton de levage du bras pour le soulever.
2. Une fois le bras déplacé vers le côté du tourne-disques, il commence à tourner.
3. Régler le tourne-disques sur 33-1/3 tr/min.
4. Raccorder l'amplificateur tampon à la broche ① de IC1 PA2007 sur la carte de circuit imprimé du circuit moteur, comme indiqué à la Fig. 11-3, et raccorder la sortie à un oscilloscope.
5. Lorsque la forme d'onde indiquée à la Fig. 11-4 apparaît sur l'oscilloscope, régler le gain de l'oscilloscope de façon à ce que le sommet de l'onde en dent de scie se situe sur la division 5. Ajuster ensuite VR1 (33-1/3 tr/min) pour a:b = 2,7:2,3, comme indiqué à la Fig. 11-4. (Faire attention car les parasites s'introduisent facilement.)
6. En fin de réglage pour 33-1/3 tr/min, régler VR2 pour 45 tr/min, comme indiqué dans 2 et 3 ci-dessus. Le réglage pour 33-1/3 tr/min doit toujours être effectué en premier.  
Le réglage de 45 tr/min doit toujours être réalisé, même si seul 33-1/3 tr/min est mal réglé.
7. Raccorder un oscilloscope à la broche ⑦ de PA2007 et vérifier que la fréquence de la forme d'onde soit de 55,5Hz pour 45 tr/min.

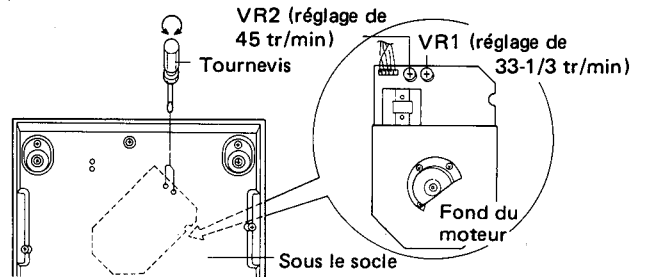
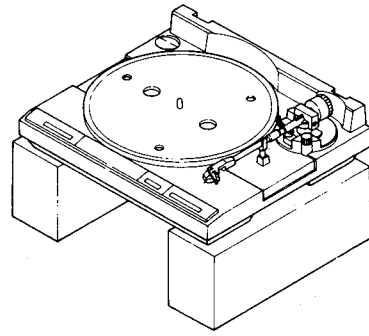

Fig. 11-2 Réglage de la vitesse de rotation du moteur

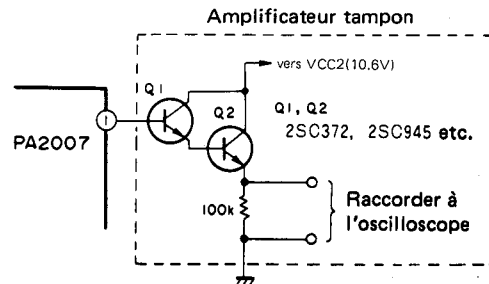

Fig. 11-3 Raccordement de l'amplificateur tampon

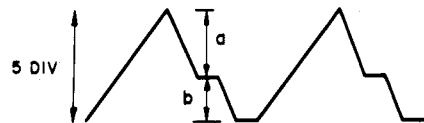

Fig. 11-4 Réglage de l'onde en dent de scie

## 11. AJUSTES

### 11.1 AJUSTE DEL MECANISMO DE CONTROL

#### ● Ajuste de la posición de retorno automático

Cuando el retorno automático se produce demasiado rápido o demasiado tarde, efectuar los ajustes siguientes.

1. Comprobar la posición de descenso de la aguja. Si la aguja no desciende en la posición correcta, ajustar la posición de descenso.
2. Ajustar el interruptor de elevación del brazo en la posición UP y girar el tornillo de ajuste de retorno automático completamente hacia la izquierda.
3. Desplazar el brazo fonocaptor hacia el interior al máximo.
4. Cuando se giran lentamente los tornillos de ajuste de retorno automático hacia la derecha, el brazo fonocaptor empezará a moverse hacia el interior.
5. Dejar de girar el tornillo de ajuste en el punto en el que haya un espacio de 32mm entre la aguja de la cápsula y el eje central. (Fig. 11-1)
6. Después del ajuste, comprobar que la operación de retorno automático se efectúe correctamente y que la posición de descenso de la aguja sea la correcta.

#### ● Ajuste de la altura de la elevación del brazo

1. Presionar el interruptor de elevación del brazo para hacerlo descender.
2. Ajustar el tornillo de debajo del giradiscos de modo que la aguja esté 11mm por encima del panel. Cuando el tornillo de ajuste se gira hacia la izquierda, se eleva la aguja.
3. Presionar el interruptor de elevación del brazo para que se eleve el brazo fonocaptor.
4. Ajustar los tornillos situados al lado del interruptor de elevación del brazo de modo que la aguja quede 25,5mm por encima del panel.

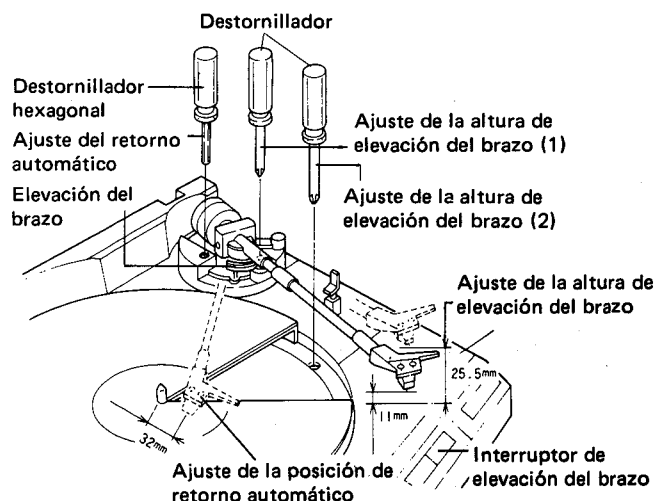

Fig. 11-1 Ajuste de la altura de elevación del brazo y ajuste del retorno automático

### 11.2 AJUSTE DEL PUNTO DE OPERACION DEL MOTOR

Poner el tocadiscos sobre bloques como se muestra en la Fig. 11-2 y ajustar el motor desde debajo de la base.

1. Presionar el interruptor de elevación del brazo para hacerlo elevar.
2. El brazo fonocaptor se mueve hacia el plato y éste empieza a girar.
3. Ajustar el giradiscos a 33-1/3 rpm.
4. Conectar el amplificador intermedio a la patilla ① del IC1 PA2007 del PCB del circuito del motor como se muestra en la Fig. 11-3 y conectar la salida a un osciloscopio.
5. Una vez aparece la forma de onda mostrada en la Fig. 11-4 en el osciloscopio, ajustar la ganancia del osciloscopio de modo que el pico de la forma de onda de diente de sierra está en la división 5. Luego, ajustar VR1 (33-1/3 rpm) a  $a:b = 2,7:2,3$  como se muestra en la Fig. 11-4. (Tener cuidado porque el ruido se introduce con facilidad.)
6. Al finalizar el ajuste de 33-1/3 rpm, ajustar las 45 rpm con VR2 como se ha descrito en los pasos 2 y 3 de arriba. Ajustar siempre primero las 33-1/3 rpm.  
Ajustar siempre las 45 rpm aunque sólo 33-1/3 rpm estén incorrectamente ajustadas.
7. Conectar un osciloscopio a la patilla ⑦ de PA2007 y comprobar que la forma de onda sea de 55,5Hz para 33-1/3 rpm y 75Hz para 45 rpm.

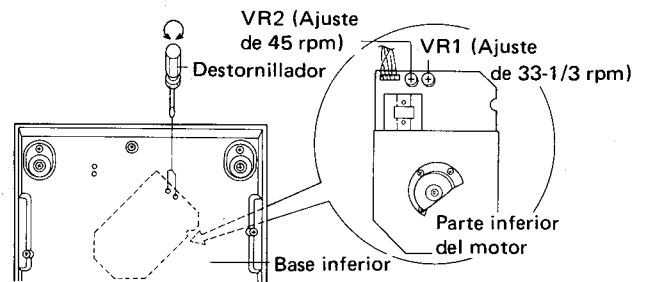
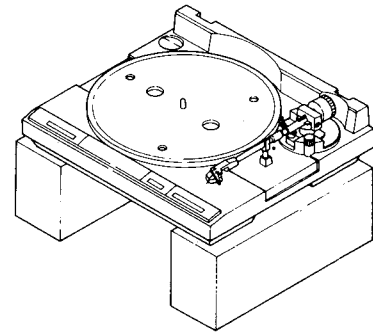

Fig. 11-2 Ajuste de la rotación del motor

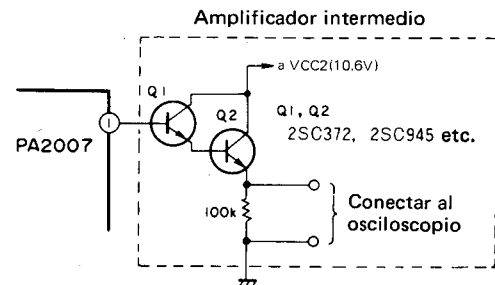

Fig. 11-3 Conexión del amplificador intermedio

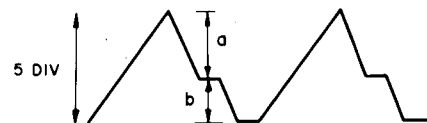

Fig. 11-4 Ajuste de la onda de diente de sierra

## 12. PRECAUTIONS FOR REASSEMBLY

Follow these directions and precautions when reassembling a unit after completing repairs. Be sure to lubricate as required, make no mistakes when attaching parts, and avoid all other careless mistakes that may be the cause of trouble later on.

### 12.1 AREAS THAT REQUIRE LUBRICATION

**NOTE:**

Types of lubricants and areas where they are used are listed in table 1.

Table 1

Type of Oil	Areas used
Silicon Oil #50000	raising shaft
GYA-008	all other areas

Lubrication points are specified for oils other than GYA-008. Never use a different type of oil.

● **Cam Section**

Apply grease to the heart-shaped grooved section (rear side of the cam) and lock plate sliding section in order to minimize wear on the sliding section and the burden on the mechanism.

● **Driving Plate Assembly**

Decrease the burden on the mechanism and the wear on the sliding section.

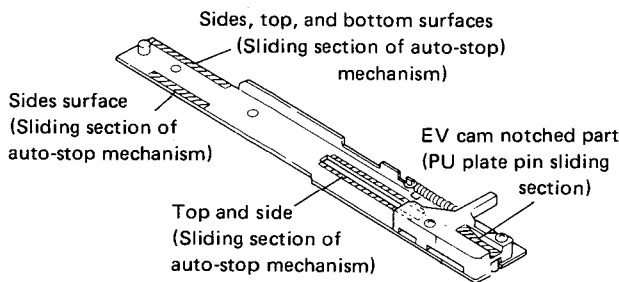

Fig. 12-1 Driving panel assembly section Switch Locker Section

● **Switch Locker Section**

Apply grease to the switch locker (opening) and sub-panel base sliding section to decrease the burden on the mechanism.

When applying grease to the opening (shaft hole), do not apply any grease 2 ~ 3mm from the bottom surface. If grease is applied 2 ~ 3mm within the bottom surface, it may come out the bottom and go between the switch lever and sub-panel base causing the switch lever to operate ineffectively.

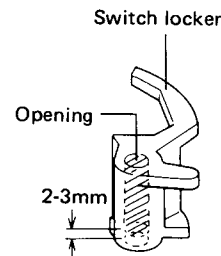
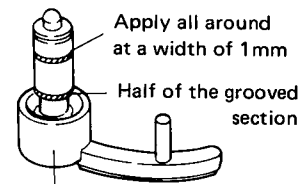

Fig. 12-2 Switch locker section

● **EV Sheet Section**

Apply oil to the raising shaft and sliding section of the bearing to assure stability in the elevation lowering speed.



EV sheet assembly

Fig. 12-3 EV sheet section

● **EV Lever Section**

Coat the EV lever shaft section with grease so the EV lever operates smoothly.

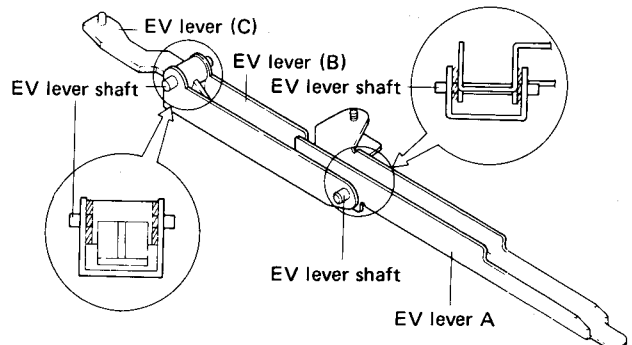

Fig. 12-4 EV lever section

● **Cut Rod Section**

Coat the cut rod support section with grease so it operates smoothly.

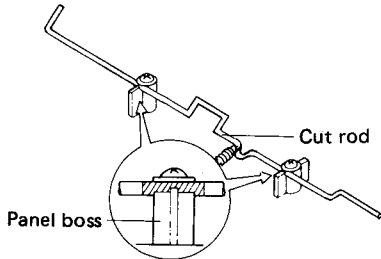

Fig. 12-5 Cut rod section

**12.2 PRECAUTIONS FOR ATTACHMENT OF PARTS AND REASSEMBLY**

● **Reset Plate SP Attachment**

As shown in Fig. 12-6, the reset plate SP hook is attached by putting the open section on the sub-panel base side.

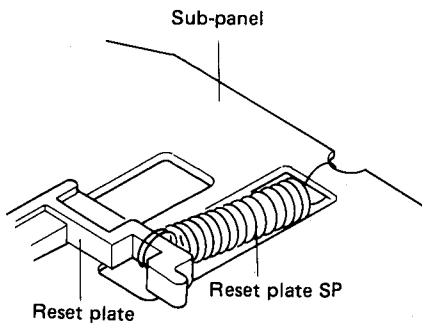

Fig. 12-6 Reset plate SP attachment

● **Cam Assembly Attachment**

The cam assembly is attached by letting the lock plate go in the direction **A** as shown in Fig. 12-7.

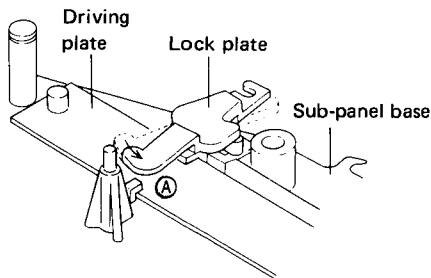

Fig. 12-7 Cam assembly attachment

● **Arm Base Attachment**

When attaching the arm base section to the mechanism section, put the mechanism section switch locker and switch lever in the locked position and verify that the tonearm is in the arm rest location. Also be sure to put the manual elevation lever in the up position and check that the PU plate shaft is in the position shown in Fig. 12-8.

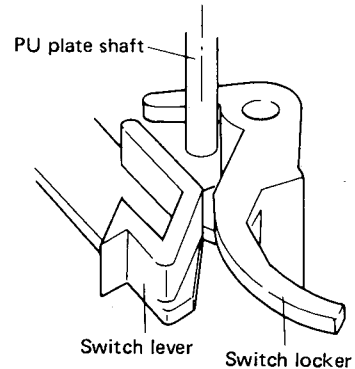

Fig. 12-8 Arm base attachment

● **PU Plate Ass'y Attachment**

The PU plate ass'y is attached by pushing the PU plate bearing section against the arm rotating shaft fixing nut.

The attachment direction is matched to the center of the support line as shown in Fig. 12-9 (tone arm position on the arm rest).

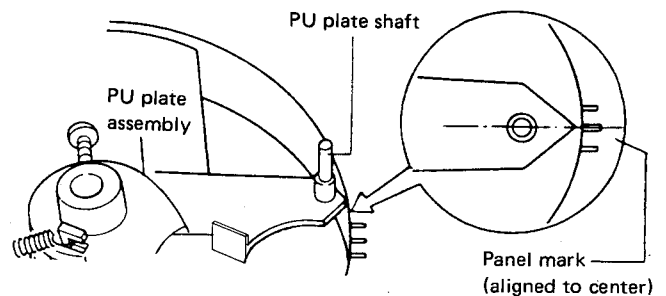

Fig. 12-9 PU plate attachment

- EV Lever Pushbutton Switch Attachment**  
 When attaching the pushbutton switch to the EV lever, insert it at the groove at the bottom of the shaft as shown in Fig. 12-10. If it is inserted at the groove at the top of the shaft, arm elevation will not operate.

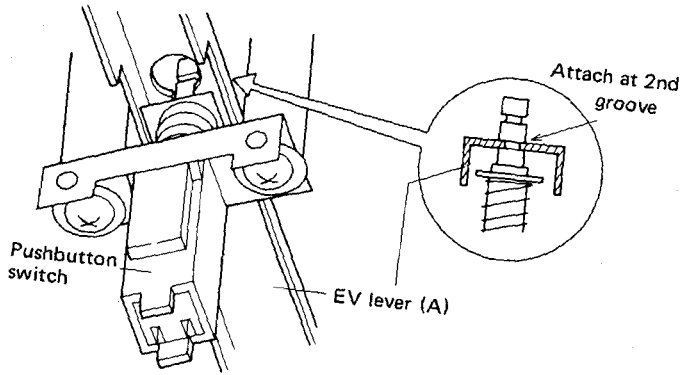

Fig. 12-10 EV lever pushbutton switch attachment

- Motor Attachment**  
 When installing the motor, set the cam in the mechanism stop location and verify that the starting plate section B does not protrude beyond surface A of the cam. If the motor is attached with the starting plate section B protruding, the starting plate may be deformed, the motor pinion gear may be scratched, and the return function may be damaged.

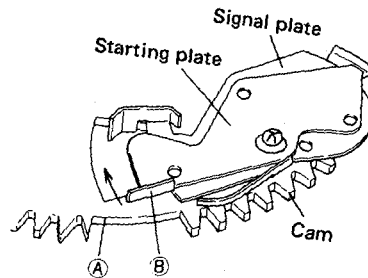

Fig. 12-12 Motor attachment

- PU lead wire position confirmation**  
 When attaching the mechanism ass'y to the panel, be careful that the PU lead wire is not pinched at the panel boss as shown in Fig. 12-11.

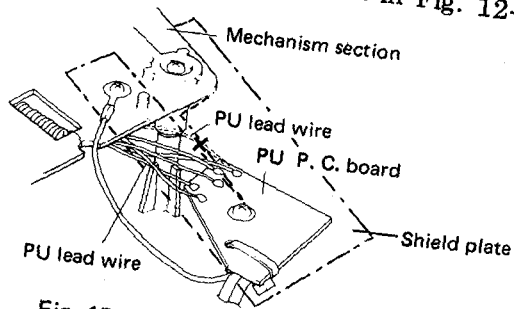

Fig. 12-11 PU lead wire attachment

- Installing the cords**  
 When installing the PU lead wire and AC power cord, install them to the panel with string as shown in Fig. 12-13.

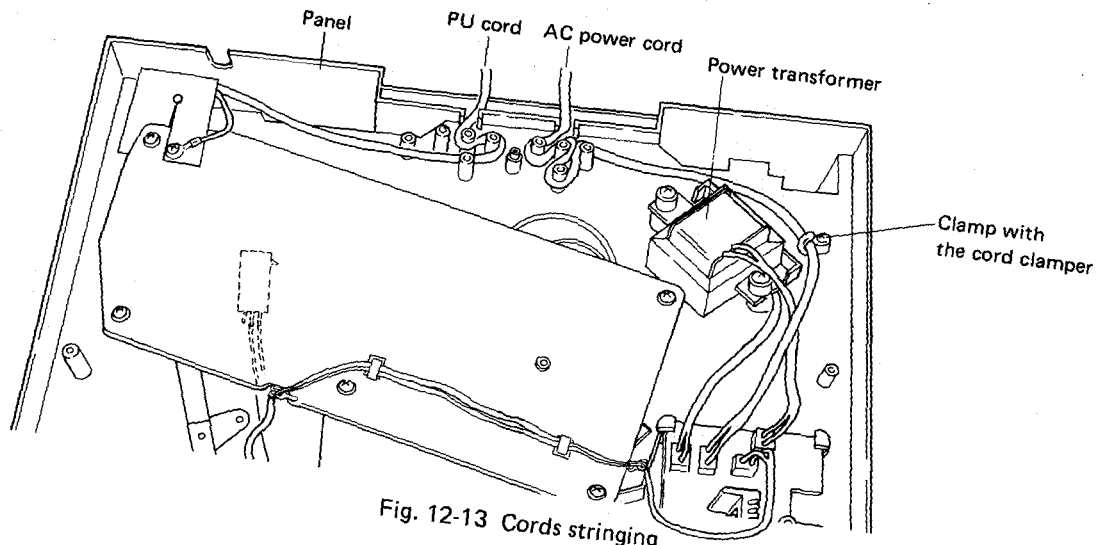

Fig. 12-13 Cords stringing

# 13. FOR PL-750/KC, R, WEM AND WP TYPES

## 13.1 CONTRAST PARTS

PL-750/KC, R, WEM and WP types are same as the PL-750/KU type except for following sections.

### Miscellaneous Parts

Mark	Symbol & Description	Part No.				
		KU type	KC type	R type	WP type	WEM type
⚠	Panel	PNY-155	PNY-155	PNY-156	PNY-155	PNY-155
⚠ ★	AC power cord assembly	PDF-206	PDF-206	PDF-147	PDF-205	PDF-209
⚠ ★	Power transformer (AC 120V)	PTX-042	PTX-043	...	...	...
	Power transformer (AC 110V ~ 120V, 220V ~ 240V)	...	...	PTX-045	...	...
⚠ ★	Power transformer (AC 220V ~ AC 240V)	...	...	...	PTX-044	PTX-044
⚠ ★★	Line voltage selector	...	...	PSB-011	...	...
	Screw 3 x 10 (For Line voltage selector)	...	...	IPZ30P100FMC	...	...
	PU cord assembly	PXB-345	PXB-333	PXB-333	PXB-333	PXB-333
	Packing case	PHH-126	PHH-127	PHH-128	PHH-128	PHH-128
	Operating instructions (Spanish)	...	...	PRC-007	...	...
	Operating instructions (English)	PRB-258	PRB-258	PRB-258	PRB-258	...
	Operating instructions (English/German/French/Italian)	...	...	...	...	PRE-025

## 13.2 SCHEMATIC DIAGRAM

For WP and WEM types

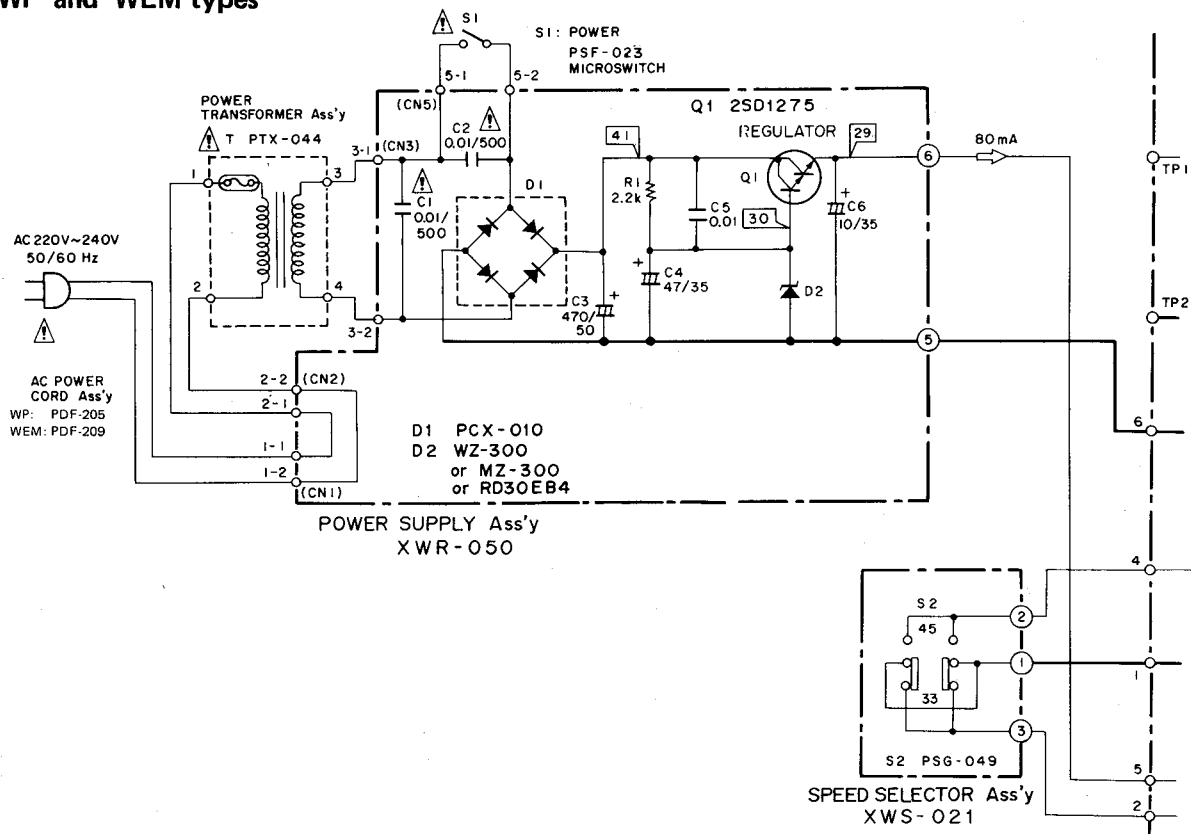



For KC type

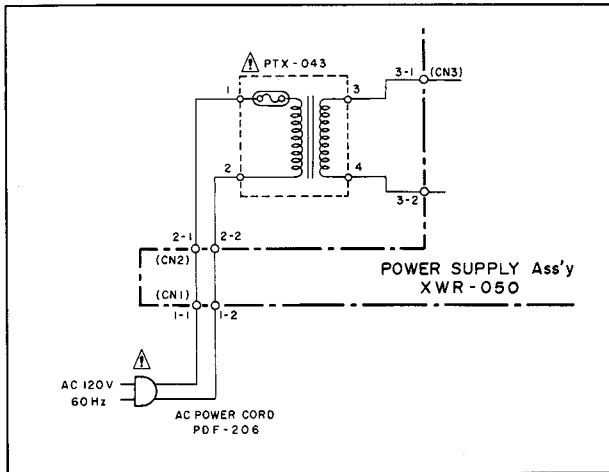

For R type

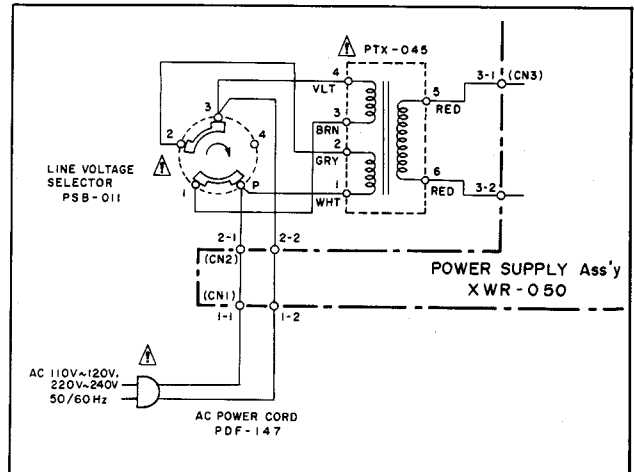

# 14. SAFETY INFORMATION

## 1. SAFETY PRECAUTIONS

The following check should be performed for the continued protection of the customer and service technician.

### LEAKAGE CURRENT CHECK

Measure leakage current to a known earth ground (water pipe, conduit, etc.) by connecting a leakage current tester such as Simpson Model 229-2 or equivalent between the earth ground and all exposed metal parts of the appliance (input/output terminals, screwheads, metal overlays, control shaft, etc.). Plug the AC line cord of the appliance directly into a 120V AC 60Hz outlet and turn the AC power switch on. Any current measured must not exceed 0.5mA.

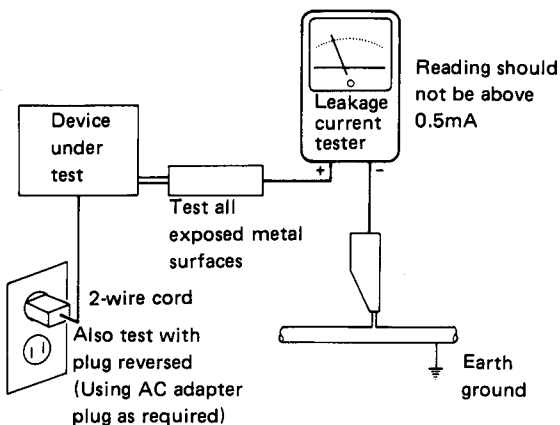

AC Leakage Test

ANY MEASUREMENTS NOT WITHIN THE LIMITS OUTLINED ABOVE ARE INDICATIVE OF A POTENTIAL SHOCK HAZARD AND MUST BE CORRECTED BEFORE RETURNING THE APPLIANCE TO THE CUSTOMER.

## 2. PRODUCT SAFETY NOTICE

Many electrical and mechanical parts in the appliance have special safety related characteristics. These are often not evident from visual inspection nor the protection afforded by them necessarily can be obtained by using replacement components rated for voltage, wattage, etc. Replacement parts which have these special safety characteristics are identified in this Service Manual.

Electrical components having such features are identified by marking with a ⚠ on the schematics and on the parts list in this Service Manual.

The use of a substitute replacement component which does not have the same safety characteristics as the PIONEER recommended replacement one, shown in the parts list in this Service Manual, may create shock, fire, or other hazards.

Product Safety is continuously under review and new instructions are issued from time to time. For the latest information, always consult the current PIONEER Service Manual. A subscription to, or additional copies of, PIONEER Service Manual may be obtained at a nominal charge from PIONEER.



**QUESTIONNAIRE**

MODEL \_\_\_\_\_

One Model per questionnaire

Dear Servicer,

Thank you for your cooperation in the post-sale service of Pioneer products.

This questionnaire is used as a tool to improve the serviceability of our products and service manuals. Please evaluate this model and service manual by answering the following questions. Your ideas may be realized in our future products. Your answers will be appreciated. Thank you.

PIONEER ELECTRONIC CORP.

T. Nakagawa, Manager, Service Section, International Division

1. SERVICING EVALUATION	Circle applicable number:	Good	Fair	Poor		
a. Disassembly/Re-assembly:		1	2	3	*4	*5
b. Circuit Checks:		1	2	3	*4	*5
c. Replacement of Parts:		1	2	3	*4	*5
d. Adjustment (s):		1	2	3	*4	*5

\* If (4) or (5) was circled, please be specific.

e. Your advice, opinion or ideas related to servicing this product.

**2. SERVICE MANUAL EVALUATION**

a. Circuit & Mechanism Description

b. Circuit Diagram

**3. OTHER**

Please describe other areas of servicing which you may find difficult.

Completed by :

Date :

Company Name :

Address :

City/State/Zip :

Please send this form filled to the distributor in your country.

## QUESTIONNAIRE

Modèle \_\_\_\_\_

Un modèle par questionnaire

Cher Monsieur,

Merci pour votre coopération à propos du service après-vente des produits PIONEER.

Ce questionnaire a pour but l'amélioration de notre service d'entretien et des manuels de nos produits. Nous vous prions d'évaluer dans ce questionnaire les éléments de nos manuels de service. Vos conseils seront précieux et pris en considération dans la réalisation de nos produits dans l'avenir.

En vous remerciant d'avance, agréez, cher monsieur, l'expression de nos sentiments distingués.

**PIONEER ELECTRONIC CORPORATION**

T. Nakagawa, Manager, Service Section, Administration Department, International Division

1. ÉVALUATION EN FACILITÉ DE SERVICE MODÈLE	Cerclez le numéro.				
	Bon,	Passable,		Mauvais,	
a. Démontage/remontage	1	2	3	*4	*5
b. Examen de circuits	1	2	3	*4	*5
c. Rechange de pièces	1	2	3	*4	*5
d. Facilité de réglage	1	2	3	*4	*5

\* Si vous cerclez No. 4 ou 5, donnez l'explication concrète.

e. Votre conseil ou avis sur le service

## 2. VOTRE APPRÉCIATION DU MANUEL DE SERVICE

a. Circuit et description du mécanisme.

b. Diagramme du circuit.

## 3. AUTRES

Anotez les autres points difficiles à réparer.

Répondu par :

Date :

Nom :

Âge :

Compagnie :

Adresse :

Adressez-vous ce questionnaire au distributeur, S.V.P.

ENCUESTA

Modelo \_\_\_\_\_

Uno modelo por encuesta

Querido señor,

Muchas gracias por su cooperación en el servicio de post-venta de los productos de Pioneer. Esto es para mejorar el servicio de post-venta de nuestros productos. Les pedimos a ustedes responder a las preguntas siguientes. Su opinión e idea estarán tenido en cuenta en los productos futuros.

Nos complacemos en saludarles muy atentamente,

PIONEER ELECTRONIC CORPORATION

T. Nakagawa, Manager, Service Section, Administration Department, International Division

1. EVALUACION EN LA FACILIDAD DE SERVICIO

MODELO

Marque uno entre los numeros siguientes.

Bueno Medio Malo

a. Desmonte:

1 2 3 \*4 \*5

b. Examen de circuito:

1 2 3 \*4 \*5

c. Reemplazo de piezas:

1 2 3 \*4 \*5

d. Ajuste:

1 2 3 \*4 \*5

\* Si marca (4) o (5), ejemplifiquelo concretamente.

e. Su consejo, opinión u idea en el servicio de este modelo.

## 2. EVALUACION DEL MANUAL DE SERVICIO

a. Circuito & Descripción de mecanismos.

b. Diagrama del circuito.

## 3. OTRAS

Describe otras partes difíciles de reparar.

Respondido por :

Fecha :

Nombre :

Edad :

Compañía :

Dirección :

Manda esta encuesta al domicilio del distribuidor, por favor.